



US005937169A

United States Patent [19]
Connery et al.

[11] **Patent Number:** **5,937,169**
[45] **Date of Patent:** **Aug. 10, 1999**

- [54] **OFFLOAD OF TCP SEGMENTATION TO A SMART ADAPTER**
- [75] Inventors: **Glenn William Connery; W. Paul Sherer**, both of Sunnyvale; **Gary Jaszewski**, Los Gatos; **James S. Binder**, San Jose, all of Calif.
- [73] Assignee: **3Com Corporation**, Santa Clara, Calif.
- [21] Appl. No.: **08/960,238**
- [22] Filed: **Oct. 29, 1997**
- [51] **Int. Cl.⁶** **G06F 13/38**
- [52] **U.S. Cl.** **395/200.8**
- [58] **Field of Search** 364/DIG. 1, DIG. 2; 395/200.3, 200.36, 200.37, 200.48, 200.5, 200.53, 200.55, 200.6, 200.66, 200.8

“Internet Protocol: DARPA Internet Program Protocol Specification”, rfc 791, prepared by Univ. of Southern Calif., dated Sep. 1981, printed from web site “http:// www.cis.ohio-state.edu/htbin/rfc”, 42 pages.

Gilbert, H., “Introduction to TCP/IP”, dated Feb. 2, 1995, printed from web site “http://pelt.cis.yale.edu/pelt/comm/tcpip.htm”, 5 pages.

Primary Examiner—Robert B. Harrell
Attorney, Agent, or Firm—Mark A. Haynes; Wilson, Sonsini, Goodrich & Rosati

[57] **ABSTRACT**

A method is provided for sending data from a data source executing a network protocol such as the TCP/IP protocol stack, which includes a process for generating headers for packets according to the network protocol. The method includes sending such data on a network through a smart network interface. The network protocol defines a datagram in the data source, including generating a header template and supplying a data payload. The datagram is supplied to the network interface. At the network interface, a plurality of packets of data are generated from the datagram. The plurality of packets include respective headers, such as TCP/IP headers, based on the header template, and include respective segments of the data payload. The network interface supports packets having a pre-specified length, and the data payload is greater than the pre-specified length, such as two to forty times larger or more. Thus, the higher layer processing specifies a very large datagram, which is automatically segmented at the network interface layer, instead of at the TCP layer.

[56] **References Cited**

U.S. PATENT DOCUMENTS

- 5,321,819 6/1994 Szczepanek 395/200.8
- 5,727,149 3/1998 Hirata et al. 395/200.8

OTHER PUBLICATIONS

- Postel, J., “The TCP Maximum Segment Size and Related Topics”, rfc879, dated Nov. 1983, printed from web site “http:// www.cis.ohio-state.edu/htbin/rfc”, 10 pages.
- Clark, D., “Window and Acknowledgement Strategy in TCP”, rfc813, dated Jul. 1982, printed from web site “http:// www.cis.ohio-state.edu/htbin/rfc”, 18 pages.
- “Transmission Control Protocol: DARPA Internet Program Protocol Specification”, rfc793, prepared by Univ. of Southern Calif., dated Sep. 1981, printed from web site “http:// www.cis.ohio-state.edu/htbin/rfc”, 77 pages.

83 Claims, 6 Drawing Sheets

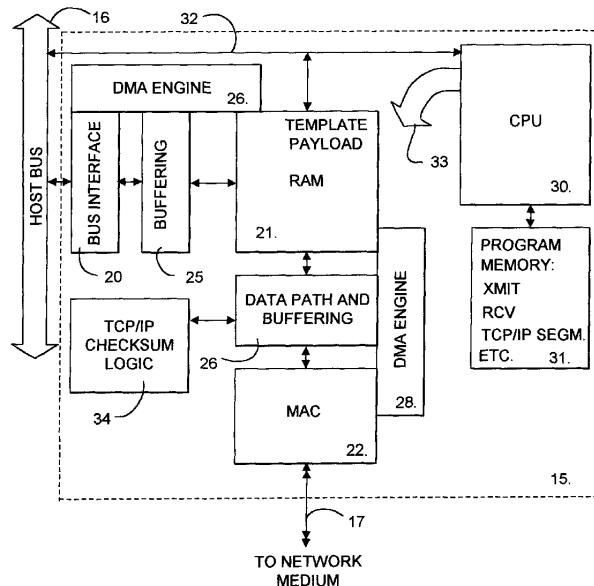

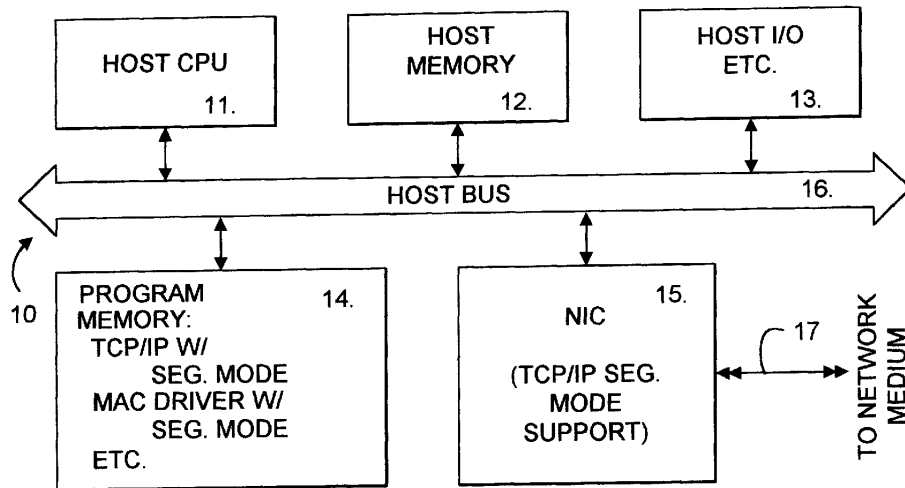

FIG. 1

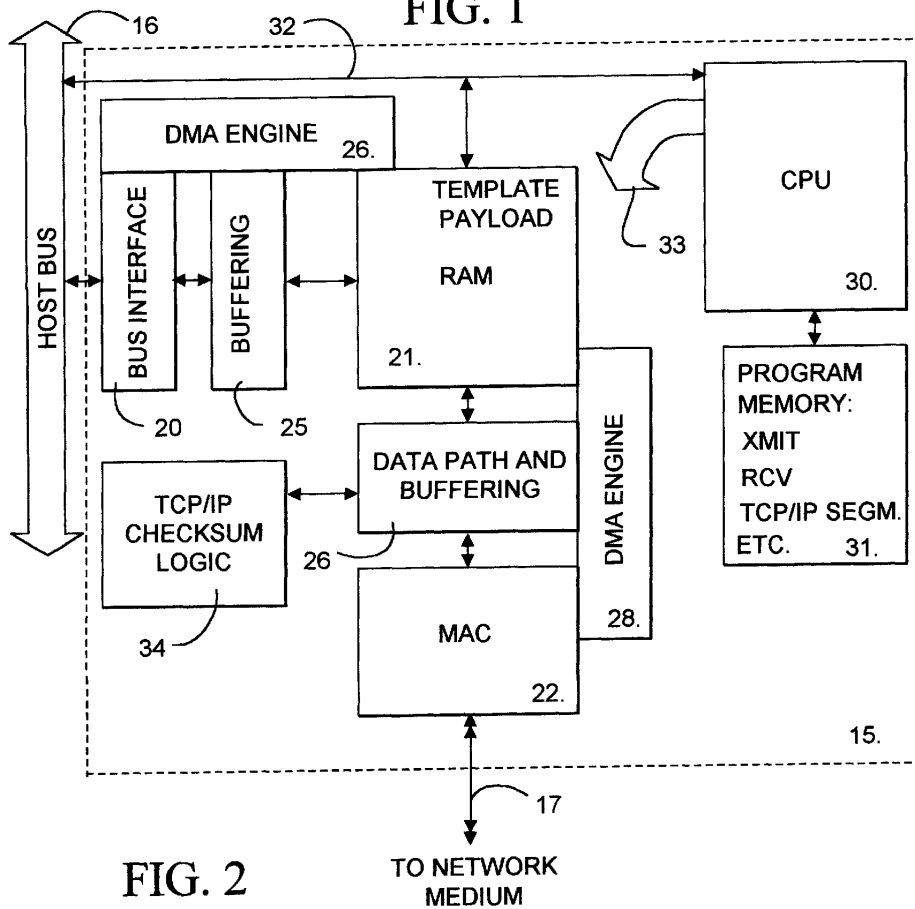

FIG. 2

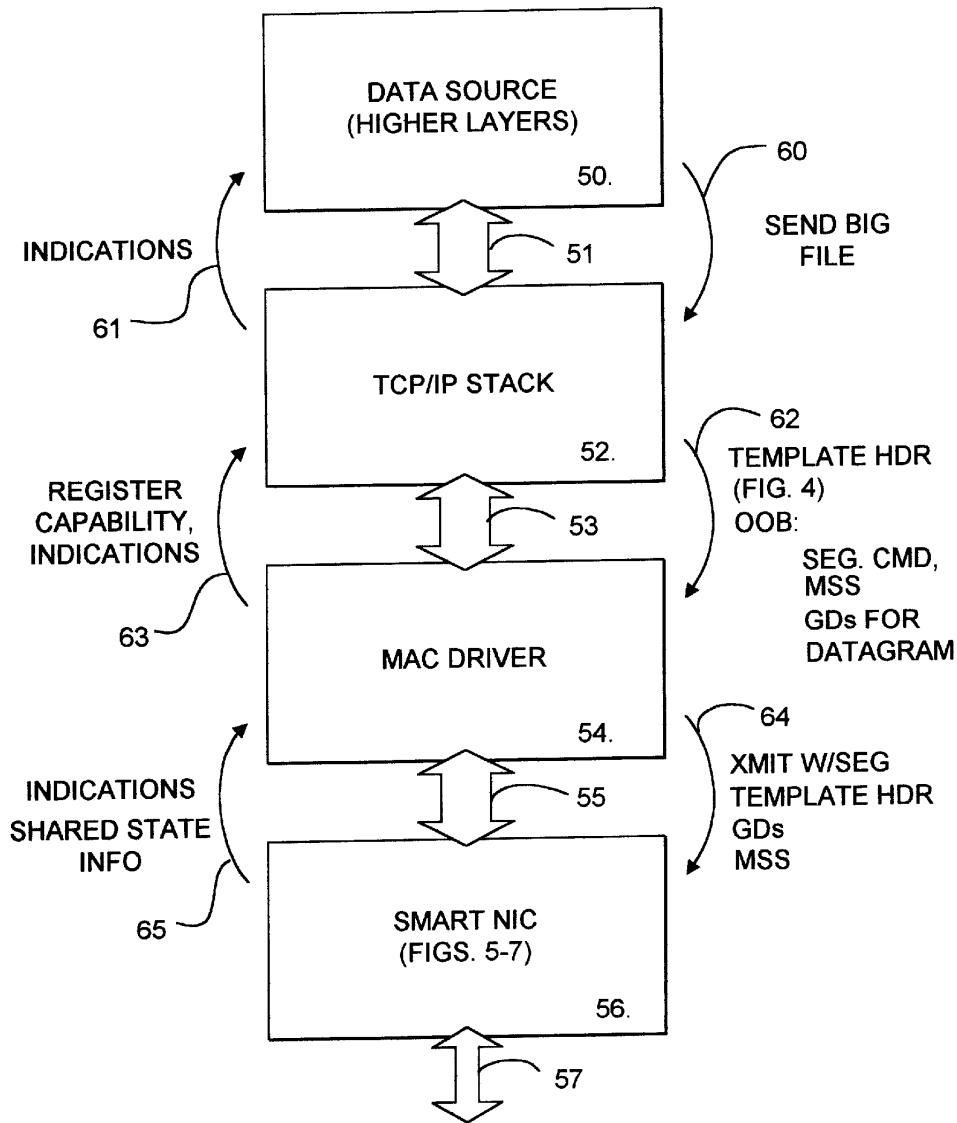

FIG. 3

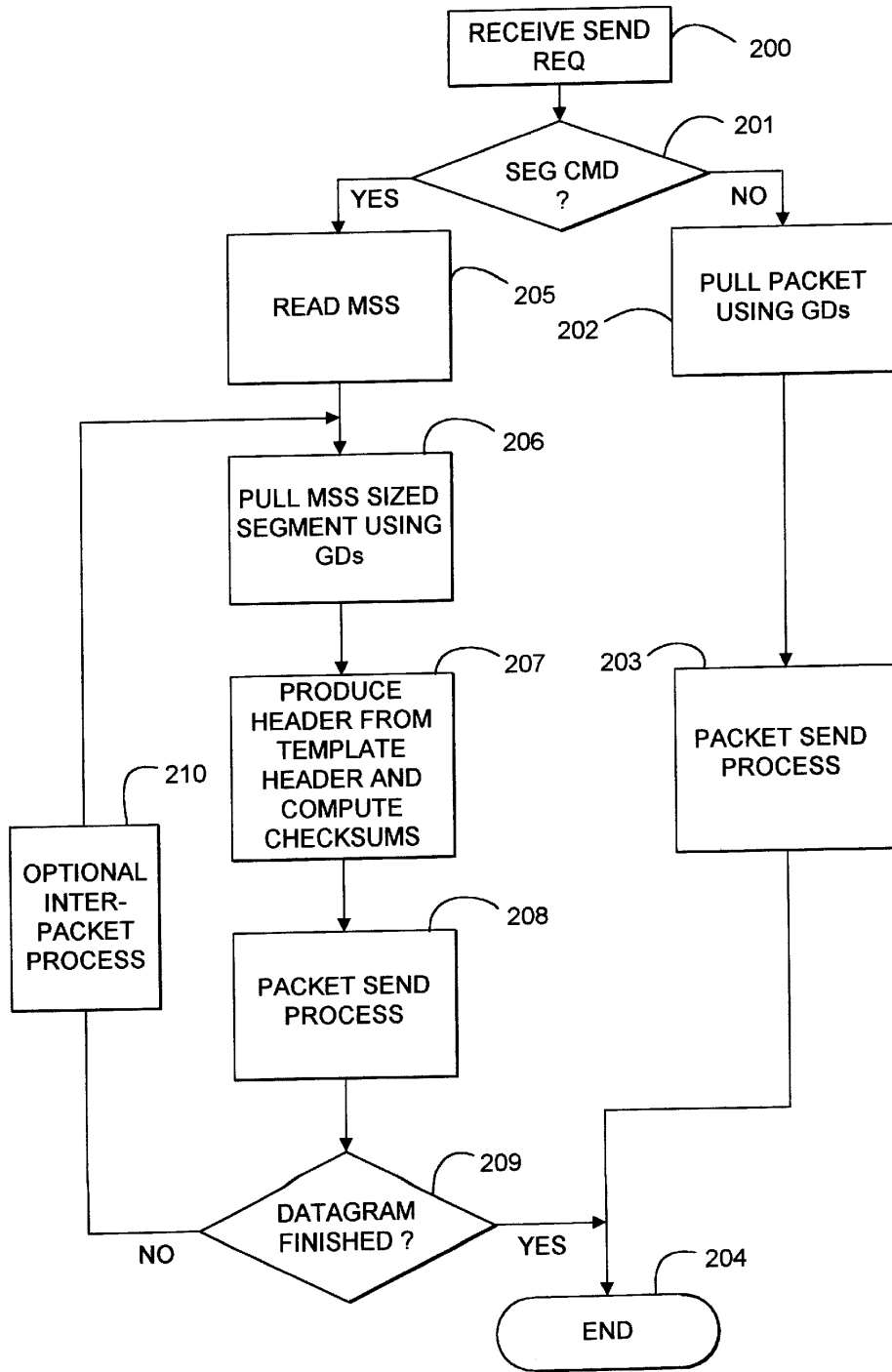

FIG. 5

Explore Litigation Insights

Docket Alarm provides insights to develop a more informed litigation strategy and the peace of mind of knowing you're on top of things.

Real-Time Litigation Alerts



Keep your litigation team up-to-date with **real-time alerts** and advanced team management tools built for the enterprise, all while greatly reducing PACER spend.

Our comprehensive service means we can handle Federal, State, and Administrative courts across the country.

Advanced Docket Research



With over 230 million records, Docket Alarm's cloud-native docket research platform finds what other services can't. Coverage includes Federal, State, plus PTAB, TTAB, ITC and NLRB decisions, all in one place.

Identify arguments that have been successful in the past with full text, pinpoint searching. Link to case law cited within any court document via Fastcase.

Analytics At Your Fingertips



Learn what happened the last time a particular judge, opposing counsel or company faced cases similar to yours.

Advanced out-of-the-box PTAB and TTAB analytics are always at your fingertips.

API

Docket Alarm offers a powerful API (application programming interface) to developers that want to integrate case filings into their apps.

LAW FIRMS

Build custom dashboards for your attorneys and clients with live data direct from the court.

Automate many repetitive legal tasks like conflict checks, document management, and marketing.

FINANCIAL INSTITUTIONS

Litigation and bankruptcy checks for companies and debtors.

E-DISCOVERY AND LEGAL VENDORS

Sync your system to PACER to automate legal marketing.