



US005954781C1

(12) **EX PARTE REEXAMINATION CERTIFICATE** (10647th)

**United States Patent**

(10) **Number:** **US 5,954,781 C1**

**Slepian et al.**

(45) **Certificate Issued:** **Jul. 7, 2015**

(54) **METHOD AND APPARATUS FOR OPTIMIZING VEHICLE OPERATION**

90/013,252, please refer to the USPTO's public Patent Application Information Retrieval (PAIR) system under the Display References tab.

(75) Inventors: **Harvey Slepian**, Peoria, IL (US); **Loran Sutton**, East Peoria, IL (US)

*Primary Examiner* — David England

(73) Assignee: **VELOCITY PATENT LLC**, Atherton, CA (US)

(57) **ABSTRACT**

**Reexamination Request:**

No. 90/013,252, May 22, 2014

Apparatus for optimizing operation of an engine-driven vehicle. The apparatus includes a processor subsystem, a memory subsystem, a road speed sensor, an engine speed sensor, a manifold pressure sensor, a throttle position sensor, a radar detector for determining the distance separating the vehicle from an object in front of it, a windshield wiper sensor for indicating whether a windshield wiper of the vehicle is activated, a brake sensor for determining whether the brakes of the vehicle have been activated, a fuel overinjection notification circuit for issuing notifications that excessive fuel is being supplied to the engine of the vehicle, an upshift notification circuit for issuing notifications that the engine of the vehicle is being operated at an excessive engine speed, a downshift notification circuit for issuing notifications that the engine of the vehicle is being operated at an insufficient engine speed, a vehicle proximity alarm circuit for issuing an alarm that the vehicle is too close to an object in front of the vehicle and a throttle controller for automatically reducing the amount of fuel supplied to the engine if the vehicle is too close to the object in front of it. Based upon data received from the sensors and data stored in the memory subsystem, the processor determines whether to activate the fuel overinjection notification circuit, the upshift notification circuit, the downshift notification circuit, the vehicle proximity alarm circuit or the throttle controller.

**Reexamination Certificate for:**

Patent No.: **5,954,781**  
Issued: **Sep. 21, 1999**  
Appl. No.: **08/813,270**  
Filed: **Mar. 10, 1997**

Disclaimer of Claims 31 and 32

Filed: Dec. 10, 2014 (1411 O.G. 243)

(51) **Int. Cl.**  
**G06F 7/00** (2006.01)  
**B60R 16/023** (2006.01)

(52) **U.S. Cl.**  
CPC .... **B60R 16/0231** (2013.01); **B60W 2510/0671** (2013.01)

(58) **Field of Classification Search**  
None  
See application file for complete search history.

(56) **References Cited**

To view the complete listing of prior art documents cited during the proceeding for Reexamination Control Number

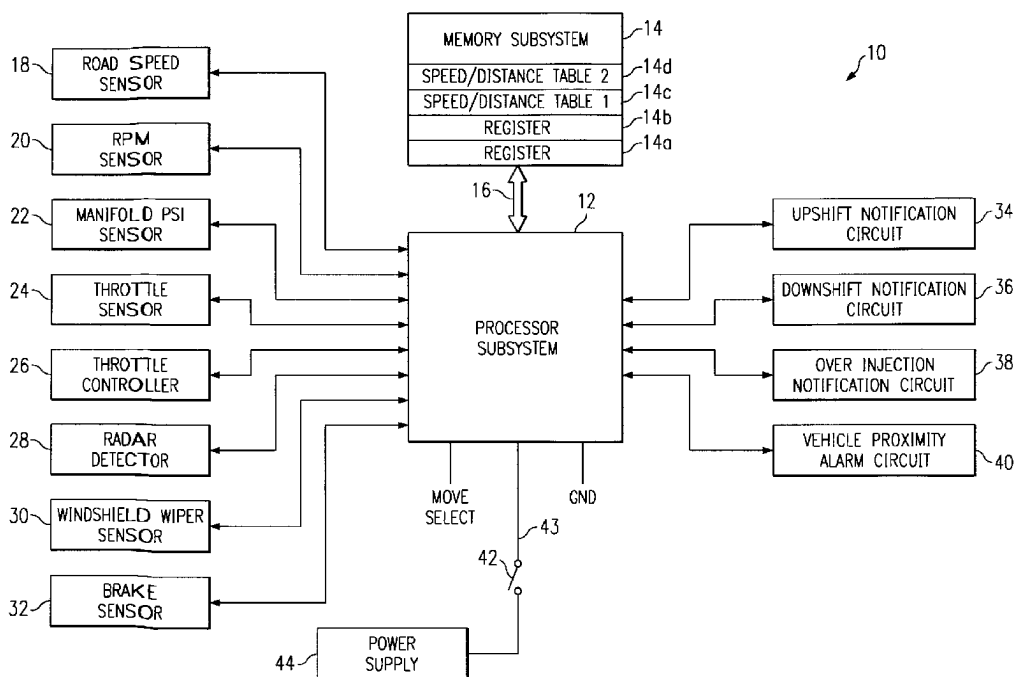

**1**  
**EX PARTE**  
**REEXAMINATION CERTIFICATE**

THE PATENT IS HEREBY AMENDED AS  
INDICATED BELOW.

**Matter enclosed in heavy brackets [ ] appeared in the patent, but has been deleted and is no longer a part of the patent; matter printed in italics indicates additions made to the patent.**

AS A RESULT OF REEXAMINATION, IT HAS BEEN DETERMINED THAT:

The patentability of claims **1, 2, 4, 5, 7, 8, 10, 12, 13, 15** and **17-30** is confirmed.

Claims **31** and **32** are now disclaimed.

New claims **33-89** are added and determined to be patentable.

Claims **3, 6, 9, 11, 14** and **16** were not reexamined.

*33. Apparatus for optimizing operation of a vehicle according to claim 1 further comprising:*

*means for determining a distance separating a vehicle and an object, wherein the vehicle includes an engine; and a vehicle proximity alarm circuit coupled to said processor subsystem, wherein the vehicle proximity alarm circuit includes at least one of a visual notification and an audible notification;*

*wherein, upon the processor subsystem receiving the distance from said means for determining a distance and determining said distance is less than a predetermined distance, the processor subsystem activates the vehicle proximity alarm circuit.*

*34. Apparatus for optimizing operation of a vehicle according to claim 33, further comprising:*

*a throttle controller for controlling a throttle of said engine of said vehicle;*

*wherein, upon the processor subsystem receiving the distance from said means for determining a distance and determining said distance received is less than a predetermined distance, the processor subsystem reduces said throttle.*

*35. Apparatus for optimizing operation of a vehicle according to claim 34, wherein the processor subsystem includes (i) an active mode wherein the processor subsystem activates an alarm and reduces the throttle based upon the distance received from said means for determining, and (ii) an inactive mode wherein the processor subsystem activates an alarm and the processor subsystem does not reduce the throttle based upon the distance received from said means for determining.*

*36. Apparatus for optimizing operation of a vehicle according to claim 35, further comprising a mode select line for switching between said active mode and said inactive mode.*

*37. Apparatus for optimizing operation of a vehicle according to claim 33, further wherein the processor subsystem determines whether the brakes of the vehicle are activated.*

*38. Apparatus for optimizing operation of a vehicle according to claim 33, wherein the vehicle proximity alarm circuit further comprises a display for displaying at least one of the speed of the object, and the distance to the object.*

*39. Apparatus for optimizing operation of a vehicle according to claim 1, wherein said plurality of sensors is the engine speed sensor and the vehicle speed sensor.*

**2**

*40. Apparatus for optimizing operation of a vehicle according to claim 1, wherein said notification that the engine is being operated an excessive speed comprises an automatic corrective action by the vehicle.*

*41. Apparatus for optimizing operation of a vehicle according to claim 1, wherein said notification that the engine is being operated at an excessive speed notifies a driver that an upshift should be performed.*

*42. Apparatus for optimizing operation of a vehicle according to claim 1, wherein said notification that excessive fuel is being supplied to said engine of said vehicle notifies a driver that the vehicle is not being operated fuel efficiently.*

*43. Apparatus for optimizing operation of a vehicle according to claim 1, wherein said manifold pressure set point is a manifold pressure threshold value.*

*44. Apparatus for optimizing operation of a vehicle according to claim 1, wherein said manifold pressure set point is a threshold value above which the manifold pressure should not exceed.*

*45. Apparatus for optimizing operation of a vehicle according to claim 1, wherein said processor subsystem determines when to activate said fuel overinjection circuit and said upshift notification circuit based upon said manifold pressure set point and said RPM set point.*

*46. Apparatus for optimizing operation of a vehicle according to claim 1, wherein said determination to activate said fuel overinjection circuit is based on data from the road speed sensor.*

*47. Apparatus for optimizing operation of a vehicle according to claim 1, wherein said determination to activate said fuel overinjection circuit is based on data from the manifold pressure sensor.*

*48. Apparatus for optimizing operation of a vehicle according to claim 1, wherein said determination to activate said fuel overinjection circuit is based on data from the throttle position sensor.*

*49. Apparatus for optimizing operation of a vehicle according to claim 1, wherein said processor subsystem is configured to automatically power on when the vehicle is started.*

*50. Apparatus for optimizing operation of a vehicle according to claim 1, wherein said determination when to activate said fuel overinjection circuit and said determination when to activate said upshift notification circuit is based upon said present and prior levels for said plurality of sensors stored in said memory subsystem.*

*51. Apparatus for optimizing operation of a vehicle according to claim 1, wherein said processor subsystem is configured to periodically communicate with said plurality of sensors.*

*52. Apparatus for optimizing operation of a vehicle according to claim 1, wherein said processor subsystem is configured to retrieve data from the plurality of sensors and store the data in said memory subsystem.*

*53. Apparatus for optimizing operation of a vehicle according to claim 17, wherein the processor subsystem includes (i) an active mode wherein the processor subsystem activates an alarm and reduces the throttle based upon a distance received from said radar detector, and (ii) an inactive mode wherein the processor subsystem activates an alarm and the processor subsystem does not reduce the throttle based upon a distance received from said radar detector.*

*54. Apparatus for optimizing operation of a vehicle according to claim 53, further comprising a mode select line for switching between said active mode and said inactive mode.*

3

55. Apparatus for optimizing operation of a vehicle according to claim 17, wherein said processor subsystem activates said upshift notification circuit based on the manifold pressure set point and RPM set point.

56. Apparatus for optimizing operation of a vehicle according to claim 17, wherein said at least one sensor is the road speed sensor.

57. Apparatus for optimizing operation of a vehicle according to claim 17, wherein the first speed/stopping distance table is based on National Safety Council guidelines.

58. Apparatus for optimizing operation of a vehicle according to claim 17, further wherein said processor subsystem automatically applies the brakes based upon data received from said radar detector, said at least one sensor and said memory subsystem.

59. Apparatus for optimizing operation of a vehicle according to claim 28 further comprising:

a means for determining a distance separating a vehicle and an object, wherein the vehicle includes an engine; and

a vehicle proximity alarm circuit coupled to said processor subsystem;

wherein said processor subsystem activates said vehicle proximity alarm circuit based at least upon the data received from said road speed sensor, and the means for determining the distance separating the vehicle and the object.

60. Apparatus for optimizing operation of a vehicle, comprising:

a radar detector, said radar detector determining a distance separating a vehicle having an engine and an object in front of said vehicle;

a plurality of sensors coupled to said vehicle for monitoring operation thereof, said plurality of sensors including a road speed sensor and an engine speed sensor;

a processor subsystem, coupled to said radar detector and said at least one sensor, to receive data therefrom;

a memory subsystem, coupled to said processor subsystem, said memory subsystem storing a first vehicle speed/stopping distance table;

a vehicle proximity alarm circuit coupled to said processor subsystem, said vehicle proximity alarm circuit issuing an alarm that said vehicle is too close to said object;

said processor subsystem determining whether to activate said vehicle proximity alarm circuit based upon separation distance data received from said radar detector, vehicle speed data received from said road speed sensor and said first vehicle speed/stopping distance table stored in said memory subsystem; and

a throttle controller for controlling a throttle of said engine of said vehicle;

wherein said processor subsystem selectively reduces said throttle based upon the data received from said radar detector;

further wherein the processor subsystem includes (i) an active mode in which the processor subsystem activates the vehicle proximity alarm circuit to issue the vehicle proximity alarm and reduces the throttle based upon the data received from said radar detector, and (ii) an inactive mode in which the processor subsystem activates the vehicle proximity alarm circuit to issue the alarm and the throttle is not selectively reduced based upon the data received from said radar detector;

a fuel overinjection notification circuit coupled to said processor subsystem, said fuel overinjection notification circuit issuing a notification that excessive fuel is being supplied to said engine of said vehicle;

4

wherein said processor subsystem determines whether to activate said fuel overinjection notification circuit based upon at least the data received from said road speed sensor.

61. Apparatus for optimizing operation of a vehicle according to claim 60, wherein said first speed/stopping distance table is a lookup table.

62. Apparatus for optimizing operation of a vehicle according to claim 60, wherein said first speed/stopping distance table is based upon National Safety Council guidelines.

63. Apparatus for optimizing operation of a vehicle according to claim 60, wherein said vehicle comprises a truck.

64. Apparatus for optimizing operation of a vehicle according to claim 60, wherein said memory subsystem stores vehicle class information.

65. Apparatus for optimizing operation of a vehicle according to claim 60, wherein said processor subsystem is configured to automatically power on when the vehicle is started.

66. Apparatus for optimizing operation of a vehicle according to claim 60, wherein said first speed/stopping distance table is the relationship between vehicle speed and stopping distance.

67. Apparatus for optimizing operation of a vehicle according to claim 60 wherein:

said plurality of sensors further including a windshield wiper sensor for indicating whether a windshield wiper of said vehicle is activated; and

said memory subsystem further storing a second vehicle speed/stopping distance table;

if said windshield wiper sensor indicates that said windshield wiper is deactivated, said processor subsystem determining whether to activate said vehicle proximity alarm circuit based upon data received from said radar detector, said road speed sensor and said first vehicle speed/stopping distance table stored in said memory subsystem;

if said windshield wiper sensor indicates that said windshield wiper is activated, said processor subsystem determining whether to activate said vehicle proximity alarm circuit based upon data received from said radar detector, said road speed sensor and said second vehicle speed/stopping distance table stored in said memory subsystem.

68. Apparatus for optimizing operation of a vehicle according to claim 60, further comprising:

a display;

wherein the vehicle proximity alarm includes at least one of an audible and a visual indication; and

wherein the visual indication is displayed on the display.

69. Apparatus for optimizing operation of a vehicle, comprising:

a tachometer;

a radar detector, said radar detector determining a distance separating a vehicle having an engine and an object in front of said vehicle;

a plurality of sensors coupled to said vehicle for monitoring operation thereof, said plurality of sensors including a road speed sensor, an engine speed sensor and a brake sensor;

a processor subsystem, coupled to said radar detector and said at least one sensor, to receive data therefrom;

a memory subsystem including random access memory, coupled to said processor subsystem, said memory subsystem storing a first vehicle speed/stopping distance table;

5

a vehicle proximity alarm circuit coupled to said processor subsystem, said vehicle proximity alarm circuit issuing an alarm that said vehicle is too close to said object; said processor subsystem determining whether to activate said vehicle proximity alarm circuit based upon separation distance data received from said radar detector, vehicle speed data received from said road speed sensor and said first vehicle speed/stopping distance table stored in said memory subsystem; a throttle controller for controlling a throttle of said engine of said vehicle; wherein said processor subsystem selectively reduces said throttle based upon the data received from said radar detector; further wherein the processor subsystem includes (i) an active mode in which the processor subsystem activates the vehicle proximity alarm circuit to issue the vehicle proximity alarm and reduces the throttle based upon the data received from said radar detector, and (ii) an inactive mode in which the processor subsystem activates the vehicle proximity alarm circuit to issue the alarm and the throttle is not selectively reduced based upon the data received from said radar detector; a fuel overinjection notification circuit coupled to said processor subsystem, said fuel overinjection notification circuit issuing a notification that excessive fuel is being supplied to said engine of said vehicle; an upshift notification circuit coupled to said processor subsystem.

70. Apparatus for optimizing operation of a vehicle according to claim 69, further comprising a mode select line for switching between said active mode and said inactive mode.

71. Apparatus for optimizing operation of a vehicle according to claim 70, further comprising:

a display;

wherein the vehicle proximity alarm includes at least one of an audible and a visual indication; and

wherein the visual indication is displayed on the display.

72. Apparatus for optimizing operation of a vehicle according to claim 71, further comprising a selector for selecting a type of vehicle proximity alarm, wherein the type of vehicle proximity alarm is selected from the group consisting of an audible indication, a visual indication, and combinations thereof.

73. Apparatus for optimizing operation of a vehicle according to claim 72, wherein said memory subsystem stores vehicle class information.

74. Apparatus for optimizing operation of a vehicle according to claim 72, wherein said processor subsystem is configured to select a type of vehicle proximity alarm based on the determined distance, wherein the type of vehicle proximity alarm is selected from the group consisting of an audible indication, a visual indication, and combinations thereof.

75. Apparatus for optimizing operation of a vehicle according to claim 69, wherein said processor subsystem tracks the number of vehicle proximity alarms issued before corrective action eliminates a hazardous condition.

76. Apparatus for optimizing operation of a vehicle, comprising:

a radar detector, said radar detector determining a distance separating a vehicle having an engine and an object in front of said vehicle;

6

a plurality of sensors coupled to said vehicle for monitoring operation thereof, said plurality of sensors including a road speed sensor, an engine speed sensor and a brake sensor;

a processor subsystem, coupled to said radar detector and said at least one sensor, to receive data therefrom;

a memory subsystem, coupled to said processor subsystem, said memory subsystem storing a first vehicle speed/stopping distance table and an RPM set point;

a vehicle proximity alarm circuit coupled to said processor subsystem, said vehicle proximity alarm circuit issuing an alarm that said vehicle is too close to said object;

said processor subsystem determining whether to activate said vehicle proximity alarm circuit based upon separation distance data received from said radar detector, vehicle speed data received from said road speed sensor and said first vehicle speed/stopping distance table stored in said memory subsystem;

a throttle controller for controlling a throttle of said engine of said vehicle;

wherein said processor subsystem selectively reduces said throttle based upon the data received from said radar detector;

further wherein the processor subsystem includes (i) an active mode in which the processor subsystem activates the vehicle proximity alarm circuit to issue the vehicle proximity alarm and reduces the throttle based upon the data received from said radar detector, and (ii) an inactive mode in which the processor subsystem activates the vehicle proximity alarm circuit to issue the alarm and the throttle is not selectively reduced based upon the data received from said radar detector;

a fuel overinjection notification circuit coupled to said processor subsystem, said fuel overinjection notification circuit issuing a notification that excessive fuel is being supplied to said engine of said vehicle;

further wherein said processor subsystem determines whether a brake of the vehicle is activated based upon data received from the brake sensor.

77. Apparatus for optimizing operation of a vehicle according to claim 76, further comprising a mode select line for switching between said active mode and said inactive mode.

78. Apparatus for optimizing operation of a vehicle according to claim 77, further comprising an upshift notification circuit coupled to said processor subsystem, said upshift notification circuit issuing a notification that said engine of said vehicle is being operated at an excessive speed.

79. Apparatus for optimizing operation of a vehicle according to claim 78, further comprising a downshift notification circuit coupled to said processor subsystem, said downshift notification circuit issuing a notification that said engine of said vehicle is being operated at an insufficient engine speed.

80. Apparatus for optimizing operation of a vehicle according to claim 77, further comprising a selector for selecting a type of vehicle proximity alarm, wherein the type of vehicle proximity alarm is selected from the group consisting of an audible indication, a visual indication, and combinations thereof.

81. Apparatus for optimizing operation of a vehicle according to claim 77, further comprising a bus for bidirectional exchanges of address, data and control signals between said processor subsystem and said memory subsystem.

7

82. Apparatus for optimizing operation of a vehicle according to claim 81, wherein said memory subsystem includes at least one register for holding the level of said road speed sensor.

83. Apparatus for optimizing operation of a vehicle according to claim 77, further comprising a speedometer.

84. Apparatus for optimizing operation of a vehicle according to claim 77, further comprising a power source including voltage divider circuitry.

85. Apparatus for optimizing operation of a vehicle according to claim 77, wherein said processor subsystem is configured to retrieve data from said road speed sensor and store the data in said memory subsystem.

86. Apparatus for optimizing operation of a vehicle according to claim 77, wherein said processor subsystem is configured to wait a preselected time period after issuing the vehicle proximity alarm.

87. Apparatus for optimizing operation of a vehicle according to claim 77, wherein said processor subsystem is configured to select a type of vehicle proximity alarm based

8

on the determined distance, wherein the type of vehicle proximity alarm is selected from the group consisting of an audible indication, a visual indication, and combinations thereof.

88. Apparatus for optimizing operation of a vehicle according to claim 76, further comprising:

an upshift notification circuit coupled to said processor subsystem, said upshift notification circuit issuing a notification that said engine of said vehicle is being operated at an excessive speed; and

said processor subsystem determining, based upon whether engine speed exceeds said RPM set point, when to activate said upshift notification circuit.

89. Apparatus for optimizing operation of a vehicle according to claim 76, further comprising a selector for selecting a type of vehicle proximity alarm, wherein the type of vehicle proximity alarm is selected from the group consisting of an audible indication, a visual indication, and combinations thereof.

\* \* \* \* \*





<b>Issue Classification</b> 	<b>Application/Control No.</b> 90013252	<b>Applicant(s)/Patent Under Reexamination</b> 5,954,781
	<b>Examiner</b> DAVID ENGLAND	<b>Art Unit</b> 3992

<input type="checkbox"/> <b>Claims renumbered in the same order as presented by applicant</b>																<input type="checkbox"/> <b>CPA</b>		<input type="checkbox"/> <b>T.D.</b>		<input type="checkbox"/> <b>R.1.47</b>	
Final	Original	Final	Original	Final	Original	Final	Original	Final	Original	Final	Original	Final	Original	Final	Original						
1	1	17	17	33	33	49	49		65		81	63	97	88	113						
2	2	18	18	34	34	50	50		66		82	84	98	89	114						
3	3	19	19	37	35	51	51		67		83	64	99	68	115						
4	4	20	20	38	36	52	52		68		84	65	100								
5	5	21	21	35	37	53	53		69	60	85	85	101								
6	6	22	22	36	38	54	54		70	69	86	86	102								
7	7	23	23	39	39	55	55		71	76	87	87	103								
8	8	24	24	40	40	56	56		72	77	88	66	104								
9	9	25	25	41	41	57	57		73	78	89	67	105								
10	10	26	26	42	42	58	58		74	79	90	70	106								
11	11	27	27	43	43	59	59		75	80	91	71	107								
12	12	28	28	44	44		60		76	61	92	72	108								
13	13	29	29	45	45		61		77	62	93	75	109								
14	14	30	30	46	46		62		78	81	94	73	110								
15	15		31	47	47		63		79	82	95	74	111								
16	16		32	48	48		64		80	83	96		112								

NONE		<b>Total Claims Allowed:</b>	
		87	
(Assistant Examiner)	(Date)		
/DAVID ENGLAND/ Primary Examiner. Art Unit 3992	04/09/2015	O.G. Print Claim(s)	O.G. Print Figure
(Primary Examiner)	(Date)	1	1



Docket No. 1089-001

**PATENT**

**IN THE UNITED STATES PATENT AND TRADEMARK OFFICE**

**Control No.** : 90013252                      **Confirmation No.** : 9999  
**Patent No.** : 5,954,781  
**Applicant** : Harvey Slepian  
**Reexam Filed:** May 22, 2014  
**Art Unit.** : 3992  
**Examiner** : David E. England  
**Customer No.:** 88360

Commissioner for Patents  
P.O. Box 1450  
Alexandria, VA 22313-1450

**Comments on Statement of Reasons for Patentability and/or Confirmation**

Sir:

This Response is being submitted in the above-identified Reexamination.

**Remarks** begin on page 2 of this paper.

### Remarks

Patent Owner thanks the Examiner for the Notice of Intent to Issue an Ex Parte Reexamination Certificate. The Examiner acknowledges the Patent Owner's November 3, 2014 Response, which commented on, *inter alia*, what might be perceived as ambiguities in the Examiner's statements. The Patent Owner therefore provided detailed comments in the interest of avoiding any subsequent disputes over ambiguities. In the present Notice of Intent, the Examiner states that the Examiner and the Patent Owner agree with one another. Notice of Intent, at 7 ("Examiner acknowledges the Patent Owner's response filed 11/03/2014 which agrees with the Reasons for Confirmation/Allowance made in the Non-Final Office Action date 10/21/2014.") Patent Owner therefore believes that no ambiguities remain.

For example, the Examiner notes that the overinjection notification circuit is for "alerting a driver that too much fuel is being supplied to the engine" as a consequence of the driver's operation of the vehicle. Notice of Intent, at 11. That is, the fuel overinjection notification circuit provides a driver a notification that his or her driving is fuel efficient or inefficient (*e.g.*, a light that goes on and off when driving is fuel (in)efficient manner such as driving above a speed limit, a horn that goes on and off when driving is fuel (in)efficient, a visual indication showing a deviation below a mean value the driver knows corresponds with fuel efficient driving). *See, e.g.*, U.S. Patent No. 5,954,781, at col. 13:41-44 ("By incorporating the disclosed apparatus in a vehicle, not only will certain hazardous operations of the vehicle be avoided but also the driver will be advised of certain actions which will enable the vehicle to be operated with greater fuel

efficiency.”) (emphasis added). The Examiner also has indicated he has considered Requester Volkswagen’s co-pending petition for *inter partes* review IPR2015-00276 (“the ‘276 Petition”). In that Petition, Volkswagen argued that an “indicator light” in U.S. Patent No. 4,398,174 (“Smith”) activated to alert “the driver the engine is being operated in a ‘fuel wasteful fashion’” corresponded with the claimed “fuel overinjection notification circuit.” See ‘276 Petition, at 9 & 16-17. Patent Owner assumes the Examiner considered Requester’s arguments regarding Smith before issuing the Notice of Intent and, therefore, no ambiguity exists with respect to the function of the fuel overinjection notification circuit.<sup>1</sup>

Underscoring the agreement between the Examiner and the Patent Owner is the Examiner’s thorough examination of new patent claims (*e.g.*, application claims 38, 54, 88, and 106). The Examiner presumably also thoroughly examined and approved as patentable claim 42, which provides: “Apparatus for optimizing operation of a vehicle according to claim 1, wherein said notification that excessive fuel is being supplied to said engine of said vehicle notifies a driver that the vehicle is not being operated fuel efficiently.” The Examiner would not have allowed this claim unless the Patent Owner and Examiner agreed with one another with respect to the function of the fuel overinjection notification circuit. *See, e.g., Frank’s Casing Crews & Rental Tools, Inc. v. Weatherford Int’l, Inc.*, 389 F.3d 1370, 1377 (Fed. Cir. 2004) (“If possible, the court construes claim terms ‘in a manner that renders the patent internally consistent.’”) (quoting *Budde v. Harley-Davidson, Inc.*, 250 F.3d 1369, 1379-80 (Fed. Cir. 2001).) To

---

<sup>1</sup> Patent Owner did not dispute that Smith disclosed a fuel overinjection notification circuit, but responded to Volkswagen’s petition that Smith failed to disclose numerous elements (in addition to many other deficiencies in Volkswagen’s petition).

Control No. 90013252

the extent that Patent Owner has missed anything, Patent Owner would appreciate being so advised. To the extent that nothing has been missed, Patent Owner desires that the Reexamination Certificate issue as expeditiously as possible.

Finally, Patent Owner respectfully disagrees that application claims 86 and 87 were not patentable over U.S. Patent No. 5,905,457 ("Rashid"). Nevertheless, in the interest of expediting prosecution under the circumstances, Patent Owner has accepted the Examiner's amendments to claims 86 and 87 (and the remaining amendments).

Respectfully submitted,

RICHARDS PATENT LAW PC



Patrick D. Richards  
Registration. No. 48,905

**Please recognize Customer No. 88360  
as the correspondence address.**

Richards Patent Law P.C.  
233 S. Wacker Dr., 84<sup>th</sup> Floor  
Chicago, IL 60606  
Phone: (312) 283-8555  
**Date: May 5, 2015**

## Electronic Acknowledgement Receipt

<b>EFS ID:</b>	22262585
<b>Application Number:</b>	90013252
<b>International Application Number:</b>	
<b>Confirmation Number:</b>	9999
<b>Title of Invention:</b>	Method and Apparatus for Optimizing Vehicle Operation
<b>First Named Inventor/Applicant Name:</b>	5,954,781
<b>Customer Number:</b>	88360
<b>Filer:</b>	Patrick Duffy Richards
<b>Filer Authorized By:</b>	
<b>Attorney Docket Number:</b>	
<b>Receipt Date:</b>	05-MAY-2015
<b>Filing Date:</b>	22-MAY-2014
<b>Time Stamp:</b>	17:16:52
<b>Application Type:</b>	Reexam (Third Party)

### Payment information:

Submitted with Payment	no
------------------------	----

### File Listing:

Document Number	Document Description	File Name	File Size(Bytes)/ Message Digest	Multi Part /.zip	Pages (if appl.)
1	Patent Owner Comments after Action Closing Prosecution	Comments.pdf	114208 <small>c6e05e927dc75dd946a2baba95cac7a09f945898</small>	no	4

### Warnings:

### Information:

This Acknowledgement Receipt evidences receipt on the noted date by the USPTO of the indicated documents, characterized by the applicant, and including page counts, where applicable. It serves as evidence of receipt similar to a Post Card, as described in MPEP 503.

**New Applications Under 35 U.S.C. 111**

If a new application is being filed and the application includes the necessary components for a filing date (see 37 CFR 1.53(b)-(d) and MPEP 506), a Filing Receipt (37 CFR 1.54) will be issued in due course and the date shown on this Acknowledgement Receipt will establish the filing date of the application.

**National Stage of an International Application under 35 U.S.C. 371**

If a timely submission to enter the national stage of an international application is compliant with the conditions of 35 U.S.C. 371 and other applicable requirements a Form PCT/DO/EO/903 indicating acceptance of the application as a national stage submission under 35 U.S.C. 371 will be issued in addition to the Filing Receipt, in due course.

**New International Application Filed with the USPTO as a Receiving Office**

If a new international application is being filed and the international application includes the necessary components for an international filing date (see PCT Article 11 and MPEP 1810), a Notification of the International Application Number and of the International Filing Date (Form PCT/RO/105) will be issued in due course, subject to prescriptions concerning national security, and the date shown on this Acknowledgement Receipt will establish the international filing date of the application.



UNITED STATES PATENT AND TRADEMARK OFFICE

UNITED STATES DEPARTMENT OF COMMERCE  
United States Patent and Trademark Office  
Address: COMMISSIONER FOR PATENTS  
P. O. Box 1450  
Alexandria, Virginia 22313-1450  
www.uspto.gov

APPLICATION NO.	FILING DATE	FIRST NAMED INVENTOR	ATTORNEY DOCKET NO.	CONFIRMATION NO.
90/013,252	05/22/2014	5,954,781		9999

88360 7590 04/27/2015  
Richards Patent Law P.C.  
233 S. Wacker Dr., 84th Floor  
Chicago, IL 60606

EXAMINER

ENGLAND, DAVID E

ART UNIT	PAPER NUMBER
3992	

MAIL DATE	DELIVERY MODE
04/27/2015	PAPER

**Please find below and/or attached an Office communication concerning this application or proceeding.**

The time period for reply, if any, is set in the attached communication.



**DO NOT USE IN PALM PRINTER**

(THIRD PARTY REQUESTER'S CORRESPONDENCE ADDRESS)

KENYON & KENYON LLP

ONE BROADWAY

NEW YORK, NY 10004

***EX PARTE* REEXAMINATION COMMUNICATION TRANSMITTAL FORM**

REEXAMINATION CONTROL NO. 90/013,252.

PATENT NO. 5,954,781.

ART UNIT 3992.

Enclosed is a copy of the latest communication from the United States Patent and Trademark Office in the above identified *ex parte* reexamination proceeding (37 CFR 1.550(f)).

Where this copy is supplied after the reply by requester, 37 CFR 1.535, or the time for filing a reply has passed, no submission on behalf of the *ex parte* reexamination requester will be acknowledged or considered (37 CFR 1.550(g)).



<b>Notice of Intent to Issue Ex Parte Reexamination Certificate</b>	<b>Control No.</b> 90/013,252	<b>Patent Under Reexamination</b> 5,954,781	
	<b>Examiner</b> DAVID ENGLAND	<b>Art Unit</b> 3992	<b>AIA (First Inventor to File) Status</b> No

**-- The MAILING DATE of this communication appears on the cover sheet with the correspondence address --**

1.  Prosecution on the merits is (or remains) closed in this *ex parte* reexamination proceeding. This proceeding is subject to reopening at the initiative of the Office or upon petition. *Cf.* 37 CFR 1.313(a). A Certificate will be issued in view of
  - (a)  Patent owner's communication(s) filed: 12 March 2015.
  - (b)  Patent owner's failure to file an appropriate timely response to the Office action mailed: \_\_\_\_\_.
  - (c)  Patent owner's failure to timely file an Appeal Brief (37 CFR 41.31).
  - (d)  The decision on appeal by the  Board of Patent Appeals and Interferences  Court dated \_\_\_\_\_
  - (e)  Other: \_\_\_\_\_.
2. The Reexamination Certificate will indicate the following:
  - (a) Change in the Specification:  Yes  No
  - (b) Change in the Drawing(s):  Yes  No
  - (c) Status of the Claim(s):
    - (1) Patent claim(s) confirmed: 1, 2, 4, 5, 7, 8, 10, 12, 13, 15, 17 - 30.
    - (2) Patent claim(s) amended (including dependent on amended claim(s)): \_\_\_\_\_
    - (3) Patent claim(s) canceled: \_\_\_\_\_.
    - (4) Newly presented claim(s) patentable: 33 - 59, 85 - 111, and 113 - 115.
    - (5) Newly presented canceled claims: 60-84 and 112.
    - (6) Patent claim(s)  previously  currently disclaimed: 31,32
    - (7) Patent claim(s) not subject to reexamination: 3,6,9,11,14,16.
3.  A declaration(s)/affidavit(s) under **37 CFR 1.130(b)** was/were filed on \_\_\_\_\_.
4.  Note the attached statement of reasons for patentability and/or confirmation. Any comments considered necessary by patent owner regarding reasons for patentability and/or confirmation must be submitted promptly to avoid processing delays. Such submission(s) should be labeled: "Comments On Statement of Reasons for Patentability and/or Confirmation."
5.  Note attached NOTICE OF REFERENCES CITED (PTO-892).
6.  Note attached LIST OF REFERENCES CITED (PTO/SB/08 or PTO/SB/08 substitute).
7.  The drawing correction request filed on \_\_\_\_\_ is:  approved  disapproved.
8.  Acknowledgment is made of the priority claim under 35 U.S.C. § 119(a)-(d) or (f).
  - a)  All b)  Some\* c)  None of the certified copies have
    - been received.
    - not been received.
    - been filed in Application No. \_\_\_\_\_.
    - been filed in reexamination Control No. \_\_\_\_\_.
    - been received by the International Bureau in PCT Application No. \_\_\_\_\_.

\* Certified copies not received: \_\_\_\_\_.
9.  Note attached Examiner's Amendment.
10.  Note attached Interview Summary (PTO-474).
11.  Other: \_\_\_\_\_.

**All correspondence** relating to this reexamination proceeding should be directed to the **Central Reexamination Unit** at the mail, FAX, or hand-carry addresses given at the end of this Office action.

	/DAVID ENGLAND/ Primary Examiner, Art Unit 3992
--	--

cc: Requester (if third party requester)  
U.S. Patent and Trademark Office  
PTOL-469 (Rev. 08-13)

**EXAMINER'S AMENDMENT AND STATEMENT OF REASONS FOR  
PATENTABILITY AND/OR CONFIRMATION**

An examiner's amendment to the record appears below. Should the changes and/or additions be unacceptable to applicant, an amendment may be filed as provided by 37 CFR 1.312. To ensure consideration of such an amendment, it **MUST** be submitted no later than the payment of the issue fee.

Authorization for this examiner's amendment was given in a telephone interview with Alisha Taylor Reg. No. 59332 on 04/02/2015.

Claims are to be amended as stated below and replace the PO's amendment dated 03/12/2015. Claims 38, 54, 88, and 106 deletes the claim language and typo "[means for mode selection]". Claims 86 and 87 amend in the claim limitation that was considered allowable subject matter which was indicated in the Non-Final Office Action dated 10/21/2014 of, "a fuel overinjection notification circuit coupled to said processor subsystem, said fuel overinjection notification circuit issuing a notification that excessive fuel is being supplied to said engine of said vehicle". Claim 112, a dependent claim, is canceled because it contains the claim language that was indicated as allowable and placed in the independent claim which claim 112 is connected to, independent claim 86.

**EXAMINER'S AMENDMENT**

38. (New - Amended) Apparatus for optimizing operation of a vehicle according to claim 37, further comprising a mode select line for switching between said active mode and said inactive mode.

54. (New- Amended) Apparatus for optimizing operation of a vehicle according to claim 53, further comprising a mode select line for switching between said active mode and said inactive mode.

86. (New-Amended) Apparatus for optimizing operation of a vehicle, comprising:  
a tachometer;  
a radar detector, said radar detector determining a distance separating a vehicle having an engine and an object in front of said vehicle;  
a plurality of sensors coupled to said vehicle for monitoring operation thereof, said plurality of sensors including a road speed sensor, an engine speed sensor and a brake sensor;  
a processor subsystem, coupled to said radar detector and said at least one sensor, to receive data therefrom;  
a memory subsystem including random access memory, coupled to said processor subsystem, said memory subsystem storing a first vehicle speed/stopping distance table;  
a vehicle proximity alarm circuit coupled to said processor subsystem, said vehicle

proximity alarm circuit issuing an alarm that said vehicle is too close to said object;

said processor subsystem determining whether to activate said vehicle proximity alarm circuit based upon separation distance data received from said radar detector, vehicle speed data received from said road speed sensor and said first vehicle speed/stopping distance table stored in said memory subsystem;

a throttle controller for controlling a throttle of said engine of said vehicle;

wherein said processor subsystem selectively reduces said throttle based upon the data received from said radar detector;

further wherein the processor subsystem includes (i) an active mode in which the processor subsystem activates the vehicle proximity alarm circuit to issue the vehicle proximity alarm and reduces the throttle based upon the data received from said radar detector, and (ii) an inactive mode in which the processor subsystem activates the vehicle proximity alarm circuit to issue the alarm and the throttle is not selectively reduced based upon the data received from said radar detector;

a fuel overinjection notification circuit coupled to said processor subsystem, said fuel overinjection notification circuit issuing a notification that excessive fuel is being supplied to said engine of said vehicle;

an upshift notification circuit coupled to said processor subsystem.

87. (New-Amended) Apparatus for optimizing operation of a vehicle, comprising:

a radar detector, said radar detector determining a distance separating a vehicle having an

engine and an object in front of said vehicle;

a plurality of sensors coupled to said vehicle for monitoring operation thereof, said plurality of sensors including a road speed sensor, an engine speed sensor and a brake sensor;

a processor subsystem, coupled to said radar detector and said at least one sensor, to receive data therefrom;

a memory subsystem, coupled to said processor subsystem, said memory subsystem storing a first vehicle speed/stopping distance table and an RPM set point;

a vehicle proximity alarm circuit coupled to said processor subsystem, said vehicle proximity alarm circuit issuing an alarm that said vehicle is too close to said object;

said processor subsystem determining whether to activate said vehicle proximity alarm circuit based upon separation distance data received from said radar detector, vehicle speed data received from said road speed sensor and said first vehicle speed/stopping distance table stored in said memory subsystem;

a throttle controller for controlling a throttle of said engine of said vehicle;

wherein said processor subsystem selectively reduces said throttle based upon the data received from said radar detector;

further wherein the processor subsystem includes (i) an active mode in which the processor subsystem activates the vehicle proximity alarm circuit to issue the vehicle proximity alarm and reduces the throttle based upon the data received from said radar detector, and (ii) an inactive mode in which the processor subsystem activates the vehicle proximity alarm circuit to issue the alarm and the throttle is not selectively reduced based upon the data received from said radar detector;

a fuel overinjection notification circuit coupled to said processor subsystem, said fuel overinjection notification circuit issuing a notification that excessive fuel is being supplied to said engine of said vehicle;

further wherein said processor subsystem determines whether a brake of the vehicle is activated based upon data received from the brake sensor.

88. (New - Amended) Apparatus for optimizing operation of a vehicle according to claim 87, further comprising a mode select line for switching between said active mode and said inactive mode.

106. (New - Amended) Apparatus for optimizing operation of a vehicle according to claim 86, further comprising a mode select line for switching between said active mode and said inactive mode.

112. (Canceled)

## **REASONS FOR PATENTABILITY AND/OR CONFIRMATION**

The following is an examiner's statement of reasons for allowance:

As previously stated in the Non-Final Action dated 10/21/2014, the prior art of record does not specifically disclose a fuel overinjection notification circuit coupled to said processor subsystem, said fuel overinjection notification circuit issuing a notification that excessive fuel is being supplied to said engine of said vehicle.

Examiner acknowledges the PO's response filed 11/03/2014 which agrees with the Reasons for Confirmation/ Allowance made in the Non-Final Office Action dated 10/21/2014. The Examiner maintains their Reasons for Confirmation/ Allowance as restated below.

The prior art of Jurgen, Saturn '452, Toyota '599, Volkswagen '070, Davidian, and Tonkin do not disclose, alone or in combination, the limitation of "a fuel overinjection notification circuit coupled to said processor subsystem, said fuel overinjection notification circuit issuing a notification that excessive fuel is being supplied to said engine of said vehicle", as stated in claims 1, 7, 13, 17, 23, 26, and 28 of the '781 Patent.

The '781 Patent teaches the overinjection notification circuit as being activated when there is excessive fuel being supplied to the vehicle's engine. This overinjection notification circuit is activated when said processor subsystem determines, based upon data received from said plurality of sensors, when to activate said fuel overinjection circuit, see claim 1 and similarly claimed limitations found in independent claims 7, 13, 17, 23, 26, 28, and 85 – 87 and the teachings stated in the '781 Patent 12:64 – 13:35.

As previously stated, Jurgen discloses a fuel injection shut off which utilizes a threshold. This fuel shut off is activated when a threshold is reached. "During a deceleration transition, the fuel can be shut off by simply not providing a pulse width signal to the injector to minimize exhaust emissions and fuel consumption.", (e.g., Jurgen, page 12.22). "During coasting and braking, fuel consumption can be further reduced by shutting off the fuel until the engine speed decreases to slightly higher than the set idle speed. The ECU determines when fuel shutoff can occur by evaluating the throttle position, engine RPM, and vehicle speed.", (e.g., Jurgen, page 12.4). "Using the inputs of engine RPM and vehicle speed to the electronic control unit, **thresholds** can be established for limiting these **variables with fuel cutoff. When the maximum speed is achieved, the fuel injectors are shut off. When the speed decreases below the threshold, fuel injection resumes.**", (e.g., Jurgen, page 12.14). "During transition to fuel cutoff, the ignition timing is retarded from its current setting to reduce engine torque and to assist in engine braking. The fuel is then shut off During the transition, the throttle bypass valve or the main throttle valve may remain open for a short period to allow fresh air to oxidize the remaining unburned HC and CO to further reduce exhaust emissions. During development of the fuel cutoff strategy, the advantage of reduced emission effects and catalyst temperature control must be balanced against driveability requirements. The use of fuel cutoff may change the perceived amount of engine braking felt by the driver. In addition, care must be taken to avoid a 'bump' feel when entering the fuel cutoff mode, due to the change in torque.", (e.g., Jurgen, page 12.17). Though, Jurgen does teach different sensor readings being used to tell the ECU when to shut off the fuel, the threshold of these values does not cause the engine to have excess fuel, i.e., their



threshold prevents overinjection of fuel whereas the '781 Patent's thresholds allow the engine to reach a state of overinjection. Jorgen does not disclose the fuel ever being **overinjected** because of the threshold that is used and does not teach the claimed limitation stated above with regards to **overinjection**. Furthermore, adding a reference in which would teach such an overinjected state would contradict Jorgen since Jorgen's threshold would stop a secondary reference from ever being realized and would not be obvious to combine. Therefore Jorgen, alone or in combination, does not disclose a fuel overinjection notification circuit coupled to said processor subsystem, said fuel overinjection notification circuit issuing a notification that excessive fuel is being supplied to said engine of said vehicle.

Saturn '452 discloses, "A motor vehicle has a manual transmission and means for indicating to the operator a point in operation for upshifting to the next higher gear from the present gear. A method of determining the shift point is provided based upon actual operating parameters of the motor vehicle effecting current wheel torque and predicted wheel torque in the next higher gear.", (e.g., Saturn '452, Abstract). "Shift indicators are commonly used on manual transmission vehicles to assist non-expert drivers in determining when it is appropriate to shift the transmission to a higher gear in order to maximize driving fuel economy.", (e.g., Saturn '452, 1:10 – 13). Saturn '452 further discloses a threshold value close to unity providing a shift point which achieves maximum fuel economy, but does not specifically disclose a "fuel overinjection notification circuit coupled to said processor subsystem, said fuel overinjection notification circuit issuing a notification that excessive fuel is being supplied to said engine of said vehicle" either alone or in combination with the References specifically discussed in this Reexam case.

Toyota '599 discloses performing shift-up and shift-down alerts based on different criteria, one of which includes fuel consumption. Each shift position corresponding to the optimum fuel consumption rate in accordance with various parameters calculated, (e.g., Toyota '599, 2:59 – 63). Toyota '599 further discloses, "The indicator 10 includes a shift-up indicating lamp 10a and a shift-down indicating lamp 10b", (e.g., Toyota '599, 2:64 – 3:3). "However, only when either one of the assumed fuel consumption rates above is better than the current fuel consumption rate  $B_e$ , the corresponding shift-up lamp or shift-down lamp in the indicator 10 is illuminated, thus indicating the necessity of the speed change operation.", (e.g., Toyota '599, 7:29 – 38). As seen, Toyota '599 does not disclose an overinjection notification based upon data received from said plurality of sensors.

Volkswagen '070 discloses, "a display of the rout-specific fuel consumption provide in a vehicle", (e.g., Volkswagen '070, p. 9 of English translation). Volkswagen '070 further discloses, "Looking initially at operating range I remote from full load, the desired output at a lower specific fuel consumption is able to be achieved after upshifting into the next higher gear, at an operating point that lies to the left of operating range I in the diagram of Figure 1. Accordingly, the device of the present invention generates a signal that asks the operator, i.e., normally the driver, to shift to a higher gear, which is indicated in Figure 1 by the upward pointing arrow within operating range I", (e.g., Volkswagen '070, pp. 6 – 7, English translation). Volkswagen '070 teachings are towards shifting the gears of an engine and not overinjection of

fuel and alerting a driver that too much fuel is being supplied to the engine. Therefore, Volkswagen '070 does not disclose the limitation discussed above.

As to Davidian and Tonkin, as was previously seen in the Order, these reference were not the basis for the SNQ for the limitation regarding overinjection, see Order. Therefore, Davidian and Tonkin, alone or in combination with the above references, disclose, "a fuel overinjection notification circuit coupled to said processor subsystem, said fuel overinjection notification circuit issuing a notification that excessive fuel is being supplied to said engine of said vehicle".

Any comments considered necessary by PATENT OWNER regarding the above statement must be submitted promptly to avoid processing delays. Such submission by the patent owner should be labeled: "Comments on Statement of Reasons for Patentability and/or Confirmation" and will be placed in the reexamination file.

Claims 1, 2, 4, 5, 7, 8, 10, 12, 13, 15, 17 – 30, 33 – 59, 85 – 111, and 113 - 115 are confirmed as patentable in this reexamination proceeding.

***Conclusion***

Any comments considered necessary by PATENT OWNER regarding the above statement must be submitted promptly to avoid processing delays. Such submission by the patent owner should be labeled: "Comments on Statement of Reasons for Patentability and/or Confirmation" and will be placed in the reexamination file.

**Service of Papers**

All correspondence related to this ExParte reexamination proceeding should be directed:

By EFS: Registered users may submit via the electronic filing system EFS-Web, at

<https://efs.uspto.gov/efile/myportal/efs-registered>

By Mail to: Mail Stop Ex Parte Reexam

Central Reexamination Unit

Commissioner for Patents

United States Patent & Trademark Office

P.O. Box 1450

Alexandria, VA 22313-1450

By FAX to: (571) 273-9900

Central Reexamination Unit

Application/Control Number: 90/013,252  
Art Unit: 3992

Page 13

By hand: Customer Service Window  
Randolph Building  
401 Dulany Street  
Alexandria, VA 22314

Telephone numbers for reexamination inquiries:

Reexamination and Amendment practice: (571) 272-7703

Central Reexamination Unit (CRU): (571) 272-7705

Any inquiry concerning this communication or earlier communications from the examiner, or as to the status of this proceeding, should be directed to the Central Reexamination Unit at telephone number (571) 272-7705.

/David E. England/  
Primary Examiner, Art Unit 3992

Conferees:

/Michael J. Yigdall/  
Primary Examiner, Art Unit 3992

/JENNIFER MCNEIL/  
Supervisory Patent Examiner, Art Unit 3992

<b>Notice of References Cited</b>	Application/Control No. 90/013,252	Applicant(s)/Patent Under Reexamination 5,954,781	
	Examiner DAVID ENGLAND	Art Unit 3992	Page 1 of 1

**U.S. PATENT DOCUMENTS**

*	Document Number Country Code-Number-Kind Code	Date MM-YYYY	Name	Classification
*	A US-5,905,457	05-1999	Rashid, Charles	342/70
	B US-			
	C US-			
	D US-			
	E US-			
	F US-			
	G US-			
	H US-			
	I US-			
	J US-			
	K US-			
	L US-			
	M US-			

**FOREIGN PATENT DOCUMENTS**

*	Document Number Country Code-Number-Kind Code	Date MM-YYYY	Country	Name	Classification
	N				
	O				
	P				
	Q				
	R				
	S				
	T				

**NON-PATENT DOCUMENTS**

*	Include as applicable: Author, Title Date, Publisher, Edition or Volume, Pertinent Pages)
U	
V	
W	
X	

\*A copy of this reference is not being furnished with this Office action. (See MPEP § 707.05(a).)  
Dates in MM-YYYY format are publication dates. Classifications may be US or foreign.







<b>Issue Classification</b> 	<b>Application/Control No.</b> 90013252	<b>Applicant(s)/Patent Under Reexamination</b> 5,954,781
	<b>Examiner</b> DAVID ENGLAND	<b>Art Unit</b> 3992

<input type="checkbox"/> <b>Claims renumbered in the same order as presented by applicant</b>																<input type="checkbox"/> <b>CPA</b>		<input type="checkbox"/> <b>T.D.</b>		<input type="checkbox"/> <b>R.1.47</b>	
Final	Original	Final	Original	Final	Original	Final	Original	Final	Original	Final	Original	Final	Original	Final	Original						
1	1	17	17	33	33	49	49		65		81	63	97	88	113						
2	2	18	18	37	34	50	50		66		82	84	98	89	114						
3	3	19	19	37	35	51	51		67		83	64	99	68	115						
4	4	20	20	38	36	52	52		68		84	65	100								
5	5	21	21	35	37	53	53		69	60	85	85	101								
6	6	22	22	36	38	54	54		70	69	86	86	102								
7	7	23	23	39	39	55	55		71	76	87	87	103								
8	8	24	24	40	40	56	56		72	77	88	66	104								
9	9	25	25	41	41	57	57		73	78	89	67	105								
10	10	26	26	42	42	58	58		74	79	90	70	106								
11	11	27	27	43	43	59	59		75	80	91	71	107								
12	12	28	28	44	44		60		76	61	92	72	108								
13	13	29	29	45	45		61		77	62	93	75	109								
14	14	30	30	46	46		62		78	81	94	73	110								
15	15		31	47	47		63		79	82	95	74	111								
16	16		32	48	48		64		80	83	96		112								

NONE		<b>Total Claims Allowed:</b>	
		87	
(Assistant Examiner)	(Date)		
/DAVID ENGLAND/ Primary Examiner. Art Unit 3992	04/09/2015	O.G. Print Claim(s)	O.G. Print Figure
(Primary Examiner)	(Date)	1	1

<b>Reexamination</b> 	<b>Application/Control No.</b> 90013252	<b>Applicant(s)/Patent Under Reexamination</b> 5,954,781
	<b>Certificate Date</b>	<b>Certificate Number</b> C1

<b>Requester Correspondence Address:</b>	<input type="checkbox"/> <b>Patent Owner</b>	<input checked="" type="checkbox"/> <b>Third Party</b>
<p>KENYON &amp; KENYON LLP ONE BROADWAY NEW YORK, NY 10004</p>		

<b>LITIGATION REVIEW</b> <input type="checkbox"/>	/DE/ (examiner initials)	03/23/2015 (date)
Case Name		Director Initials
1:13cv8413 (OPEN)		/JM/ for IY
1:13cv8416 (CLOSED)		/JM/ for IY
1:13cv8418 (OPEN)		/JM/ for IY
1:13cv8419 (OPEN)		/JM/ for IY
1:13cv8421 (CLOSED)		/JM/ for IY

<b>COPENDING OFFICE PROCEEDINGS</b>	
<b>TYPE OF PROCEEDING</b>	<b>NUMBER</b>
1. Inter Partes Review	IPR2015-00276
2. Inter Partes Review	IPR2015-00290

	/DAVID ENGLAND/ Primary Examiner. Art Unit 3992
--	--

<b>Search Notes</b>  	<b>Application/Control No.</b>  90013252	<b>Applicant(s)/Patent Under Reexamination</b>  5,954,781
	<b>Examiner</b>  DAVID ENGLAND	<b>Art Unit</b>  3992

CPC- SEARCHED		
Symbol	Date	Examiner

CPC COMBINATION SETS - SEARCHED		
Symbol	Date	Examiner

US CLASSIFICATION SEARCHED			
Class	Subclass	Date	Examiner

SEARCH NOTES		
Search Notes	Date	Examiner
Searched references in IDS	6/18/14	/DE/
Searched references in IDS	10/06/14	/DE/
Searched references in IDS	3/30/15	/DE/
Litigation Search	3/23/2015	/DE/

INTERFERENCE SEARCH			
US Class/ CPC Symbol	US Subclass / CPC Group	Date	Examiner

	/DAVID ENGLAND/ Primary Examiner.Art Unit 3992
--	---

Receipt date: 11/03/2014

Doc code: IDS

Doc description: Information Disclosure Statement (IDS) Filed

PTO/SB/08a (3-1-10)

Approved for use through 07/31/2012. OMB 0851-0031  
U.S. Patent and Trademark Office, U.S. DEPARTMENT OF COMMERCE

Under the Paperwork Reduction Act of 1995, no persons are required to respond to a collection of information unless it contains a valid GMB control number.

<b>INFORMATION DISCLOSURE STATEMENT BY APPLICANT</b> ( Not for submission under 37 CFR 1.99)	Application Number	90013252
	Filing Date	2014-05-22
	First Named Inventor	HARVEY SLEPIAN
	Art Unit	3992
	Examiner Name	England, David E.
	Attorney Docket Number	1089-001

U.S.PATENTS								
Examiner Initial*	Cite No	Patent Number	Kind Code <sup>1</sup>	Issue Date	Name of Patentee or Applicant of cited Document	Pages, Columns, Lines where Relevant Passages or Relevant Figures Appear		
	130	5072703		1991-12-17	Loran W. Sutton			
	131	5222469		1993-06-29	Loran W. Sutton			
	132	5317998		1994-06-07	Jay L. Hanson			
	133	5432497		1995-07-11	Tony Briski			
If you wish to add additional U.S. Patent citation information please click the Add button.								
U.S.PATENT APPLICATION PUBLICATIONS								
Examiner Initial*	Cite No	Publication Number	Kind Code <sup>1</sup>	Publication Date	Name of Patentee or Applicant of cited Document	Pages, Columns, Lines where Relevant Passages or Relevant Figures Appear		
	1							
If you wish to add additional U.S. Published Application citation information please click the Add button.								
FOREIGN PATENT DOCUMENTS								
Examiner Initial*	Cite No	Foreign Document Number <sup>3</sup>	Country Code <sup>21</sup>	Kind Code <sup>4</sup>	Publication Date	Name of Patentee or Applicant of cited Document	Pages, Columns, Lines where Relevant Passages or Relevant Figures Appear	T <sup>5</sup>

EFS Web 2.1.17

ALL REFERENCES CONSIDERED EXCEPT WHERE LINED THROUGH. /DE/

/David England/

04/13/2015



Receipt date: 11/03/2014

<b>INFORMATION DISCLOSURE STATEMENT BY APPLICANT</b> ( Not for submission under 37 CFR 1.99)	Application Number	90013252
	Filing Date	2014-05-22
	First Named Inventor	HARVEY SLEPIAN
	Art Unit	3992
	Examiner Name	England, David E.
	Attorney Docket Number	1089-001

<u>100</u>	HONORABLE JUDGE MICHAEL T. MASON, Case No. 13-CV-08418 Docket # 91 Order by Honorable Judge Mason Granting in Part and Denying in Part Velocity Patent LLC's Motion to Compel 2.1(b)(1) Discovery, District Court for the Northern District of Illinois Eastern Division, Judge's Order, 2014-07-11, Chicago, Illinois.	<input type="checkbox"/>
<u>101</u>	VELOCITY PATENT LLC, Case No. 13-CV-08418 Docket # 99 Velocity Patent LLC's Objection to Order Regarding Plaintiff's Motion to Compel LPR 2.1(b)(1) Disclosures and Responses to Discovery and Plaintiff's Motion to Compel LPR 2.4(a) Disclosures, District Court for the Northern District of Illinois Eastern Division, Case Pleading, 2014-07-25, Chicago, Illinois.	<input type="checkbox"/>
<u>102</u>	AUDI OF AMERICA, INC, Case No. 13-CV-08418 Docket # 101 Audi Of America, Inc.'s Objections to Magistrate Judge Mason's Order Granting-In-Part Plaintiff's Motion to Compel, District Court for the Northern District of Illinois Eastern Division, Case Pleading, 2014-07-28, Chicago, Illinois.	<input type="checkbox"/>
<u>103</u>	HONORABLE JUDGE John W. Darrah, Case No. 13-CV-08418 Docket # 106 Order - Audi's Motion to Dismiss for Failure to State a Claim [36] is Denied, District Court for the Northern District of Illinois Eastern Division, Judge's Order, 2014-08-20, Chicago, Illinois.	<input type="checkbox"/>
<u>104</u>	HONORABLE JUDGE John W. Darrah, Case No. 13-CV-08418 Docket # 107 Memorandum Opinion and Order - Audi's Motion to Dismiss for Failure to State a Claim [36] is Denied, District Court for the Northern District of Illinois Eastern Division, Judge's Order, 2014-08-20, Chicago, Illinois.	<input type="checkbox"/>
<u>105</u>	VELOCITY PATENT LLC, Case No. 13-CV-08418 Docket # 109 Velocity Patent LLC's Motion to Compel Discovery Relating to Past Damages, District Court of the Northern District of Illinois Eastern Division, Case Pleading, 2014-09-03, Chicago, Illinois.	<input type="checkbox"/>
<u>106</u>	AUDI OF AMERICA, INC, Case No. 13-CV-08418 Docket # 110 Audi's Response to Velocity Patent LLC's Objection to Magistrate Judge Mason's July 11, 2014 Order Granting-In-Part Plaintiff's Motion to Compel, District Court for the Northern District of Illinois Eastern Division, Case Pleading, 2014-09-03, Chicago, Illinois.	<input type="checkbox"/>
<u>107</u>	VELOCITY PATENT LLC, Case No. 13-CV-08418 Docket # 112 Velocity Patent LLC's Motion for Leave to File a Reply Brief, District Court for the Northern District of Illinois Eastern Division, Case Pleading, 2014-09-15, Chicago, Illinois.	<input type="checkbox"/>
<u>108</u>	HONORABLE JUDGE John W. Darrah, Case No. 13-CV-08418 Docket # 114 Minute Entry - Plaintiff's Motion for Leave to File Reply to Audi's Opposition to Motion to Compel Discovery Relating to Past Damages [112] is granted, District Court for the Northern District of Illinois Eastern Division, Judge Minute Entry, 2014-09-16, Chicago, Illinois.	<input type="checkbox"/>
<u>109</u>	VELOCITY PATENT LLC, Case No. 13-CV-08418 Docket # 115 Velocity Patent LLC's Reply to Audi of America, Inc.'s Opposition to Motion to Compel Discovery Relating to Past Damages, District Court for the Northern District of Illinois Eastern Division, Case Pleading, 2014-09-16, Chicago, Illinois.	<input type="checkbox"/>
<u>110</u>	AUDI OF AMERICA, INC, Case No. 13-CV-08418 Docket # 118 Audi of America, Inc.'s Sur-Reply to Velocity Patent LLC's Objection to Magistrate Mason's July 11, 2014 Order Granting-In-Part Plaintiff's Motion to Compel, District Court for the Northern District of Illinois Eastern Division, Case Pleading, 2014-10-15, Chicago, Illinois.	<input type="checkbox"/>

EFS Web 2.1.13

ALL REFERENCES CONSIDERED EXCEPT WHERE LINED THROUGH. /DE/

04/13/2015

/David England/

Receipt date: 11/03/2014

<b>INFORMATION DISCLOSURE STATEMENT BY APPLICANT</b> ( Not for submission under 37 CFR 1.99)	Application Number	90013252
	Filing Date	2014-05-22
	First Named Inventor	HARVEY SLEPIAN
	Art Unit	3992
	Examiner Name	England, David E.
	Attorney Docket Number	1089-001

111	VELOCITY PATENT LLC, Case No. 13-CV-08418 Docket # 120 Velocity Patent LLC's Response to Audi of America, Inc.'s Sur-Reply Regarding Velocity Patent LLC's Objection to Judge Mason's July 11, 2014 Order Regarding Plaintiff's Motion to Compel, District Court for the Northern District of Illinois Eastern Division, Case Pleading, 2014-10-21, Chicago, Illinois.	<input type="checkbox"/>
112	MERCEDES-BENZ USA, LLC ET. AL. v. VELOCITY PATENT LLC, Case IPR2014-01247, Patent No. 5954781, Application No. 08813270, USPTO, Filing Date 2014-08-04.	<input type="checkbox"/>

If you wish to add additional non-patent literature document citation information please click the Add button

**EXAMINER SIGNATURE**

Examiner Signature	/David England/	Date Considered	04/13/2015
--------------------	-----------------	-----------------	------------

\*EXAMINER: Initial if reference considered, whether or not citation is in conformance with MPEP 609. Draw line through a citation if not in conformance and not considered. Include copy of this form with next communication to applicant.

<sup>1</sup> See Kind Codes of USPTO Patent Documents at [www.USPTO.GOV](http://www.USPTO.GOV) or MPEP 901.04. <sup>2</sup> Enter office that issued the document, by the two-letter code (WIPO Standard ST.3). <sup>3</sup> For Japanese patent documents, the indication of the year of the reign of the Emperor must precede the serial number of the patent document. <sup>4</sup> Kind of document by the appropriate symbols as indicated on the document under WIPO Standard ST.16 if possible. <sup>5</sup> Applicant is to place a check mark here if English language translation is attached.

ALL REFERENCES CONSIDERED EXCEPT WHERE LINED THROUGH. /DE/

Receipt date: 11/03/2014

<b>INFORMATION DISCLOSURE STATEMENT BY APPLICANT</b> ( Not for submission under 37 CFR 1.99)	Application Number	90013252
	Filing Date	2014-05-22
	First Named Inventor	HARVEY SLEPIAN
	Art Unit	3992
	Examiner Name	England, David E.
	Attorney Docket Number	1089-001

**CERTIFICATION STATEMENT**

Please see 37 CFR 1.97 and 1.98 to make the appropriate selection(s):

That each item of information contained in the information disclosure statement was first cited in any communication from a foreign patent office in a counterpart foreign application not more than three months prior to the filing of the information disclosure statement. See 37 CFR 1.97(e)(1).

OR

That no item of information contained in the information disclosure statement was cited in a communication from a foreign patent office in a counterpart foreign application, and, to the knowledge of the person signing the certification after making reasonable inquiry, no item of information contained in the information disclosure statement was known to any individual designated in 37 CFR 1.56(c) more than three months prior to the filing of the information disclosure statement. See 37 CFR 1.97(e)(2).

See attached certification statement.

The fee set forth in 37 CFR 1.17 (p) has been submitted herewith.

A certification statement is not submitted herewith.

**SIGNATURE**

A signature of the applicant or representative is required in accordance with CFR 1.33, 10.18. Please see CFR 1.4(d) for the form of the signature.

Signature	/Patrick D. Richards/	Date (YYYY-MM-DD)	2014-11-03
Name/Print	Patrick Richards	Registration Number	48905

This collection of information is required by 37 CFR 1.97 and 1.98. The information is required to obtain or retain a benefit by the public which is to file (and by the USPTO to process) an application. Confidentiality is governed by 35 U.S.C. 122 and 37 CFR 1.14. This collection is estimated to take 1 hour to complete, including gathering, preparing and submitting the completed application form to the USPTO. Time will vary depending upon the individual case. Any comments on the amount of time you require to complete this form and/or suggestions for reducing this burden, should be sent to the Chief Information Officer, U.S. Patent and Trademark Office, U.S. Department of Commerce, P.O. Box 1450, Alexandria, VA 22313-1450. DO NOT SEND FEES OR COMPLETED FORMS TO THIS ADDRESS. SEND TO: Commissioner for Patents, P.O. Box 1450, Alexandria, VA 22313-1450.



Receipt date: 11/03/2014

### Privacy Act Statement

The Privacy Act of 1974 (P.L. 93-579) requires that you be given certain information in connection with your submission of the attached form related to a patent application or patent. Accordingly, pursuant to the requirements of the Act, please be advised that: (1) the general authority for the collection of this information is 35 U.S.C. 2(b)(2); (2) furnishing of the information solicited is voluntary; and (3) the principal purpose for which the information is used by the U.S. Patent and Trademark Office is to process and/or examine your submission related to a patent application or patent. If you do not furnish the requested information, the U.S. Patent and Trademark Office may not be able to process and/or examine your submission, which may result in termination of proceedings or abandonment of the application or expiration of the patent.

The information provided by you in this form will be subject to the following routine uses:

1. The information on this form will be treated confidentially to the extent allowed under the Freedom of Information Act (5 U.S.C. 552) and the Privacy Act (5 U.S.C. 552a). Records from this system of records may be disclosed to the Department of Justice to determine whether the Freedom of Information Act requires disclosure of these records.
2. A record from this system of records may be disclosed, as a routine use, in the course of presenting evidence to a court, magistrate, or administrative tribunal, including disclosures to opposing counsel in the course of settlement negotiations.
3. A record in this system of records may be disclosed, as a routine use, to a Member of Congress submitting a request involving an individual, to whom the record pertains, when the individual has requested assistance from the Member with respect to the subject matter of the record.
4. A record in this system of records may be disclosed, as a routine use, to a contractor of the Agency having need for the information in order to perform a contract. Recipients of information shall be required to comply with the requirements of the Privacy Act of 1974, as amended, pursuant to 5 U.S.C. 552a(m).
5. A record related to an International Application filed under the Patent Cooperation Treaty in this system of records may be disclosed, as a routine use, to the International Bureau of the World Intellectual Property Organization, pursuant to the Patent Cooperation Treaty.
6. A record in this system of records may be disclosed, as a routine use, to another federal agency for purposes of National Security review (35 U.S.C. 181) and for review pursuant to the Atomic Energy Act (42 U.S.C. 218(c)).
7. A record from this system of records may be disclosed, as a routine use, to the Administrator, General Services, or his/her designee, during an inspection of records conducted by GSA as part of that agency's responsibility to recommend improvements in records management practices and programs, under authority of 44 U.S.C. 2904 and 2906. Such disclosure shall be made in accordance with the GSA regulations governing inspection of records for this purpose, and any other relevant (i.e., GSA or Commerce) directive. Such disclosure shall not be used to make determinations about individuals.
8. A record from this system of records may be disclosed, as a routine use, to the public after either publication of the application pursuant to 35 U.S.C. 122(b) or issuance of a patent pursuant to 35 U.S.C. 151. Further, a record may be disclosed, subject to the limitations of 37 CFR 1.14, as a routine use, to the public if the record was filed in an application which became abandoned or in which the proceedings were terminated and which application is referenced by either a published application, an application open to public inspections or an issued patent.
9. A record from this system of records may be disclosed, as a routine use, to a Federal, State, or local law enforcement agency, if the USPTO becomes aware of a violation or potential violation of law or regulation.



UNITED STATES PATENT AND TRADEMARK OFFICE

UNITED STATES DEPARTMENT OF COMMERCE  
 United States Patent and Trademark Office  
 Address: COMMISSIONER FOR PATENTS  
 P.O. Box 1450  
 Alexandria, Virginia 22313-1450  
 www.uspto.gov

BIB DATA SHEET

CONFIRMATION NO. 9999

<b>SERIAL NUMBER</b> 90/013,252	<b>FILING or 371(c) DATE</b> 05/22/2014 <b>RULE</b>	<b>CLASS</b> 701	<b>GROUP ART UNIT</b> 3992	<b>ATTORNEY DOCKET NO.</b>		
<b>APPLICANTS</b>						
<b>INVENTORS</b> 5,954,781, Residence Not Provided; VELOCITY PATENT LLC. (OWNER), ATHERTON, CA; VOLKSWAGEN GROUP OF AMERICA, INC. (3RD PTY. REQ.), HERNDON, VA; KENYON & KENYON LLP, NEW YORK, NY						
<b>** CONTINUING DATA *****</b> This application is a REX of 08/813,270 03/10/1997 PAT 5954781						
<b>** FOREIGN APPLICATIONS *****</b>						
<b>** IF REQUIRED, FOREIGN FILING LICENSE GRANTED **</b>						
Foreign Priority claimed <input type="checkbox"/> Yes <input checked="" type="checkbox"/> No	35 USC 119(a-d) conditions met <input type="checkbox"/> Yes <input checked="" type="checkbox"/> No	<input type="checkbox"/> Met after Allowance Initials	<b>STATE OR COUNTRY</b>	<b>SHEETS DRAWINGS</b>	<b>TOTAL CLAIMS</b>	<b>INDEPENDENT CLAIMS</b>
Verified and Acknowledged	/DAVID E ENGLAND/ Examiner's Signature				32	8
<b>ADDRESS</b> Richards Patent Law P.C. 233 S. Wacker Dr., 84th Floor Chicago, IL 60606 UNITED STATES						
<b>TITLE</b> Method and Apparatus for Optimizing Vehicle Operation						
<b>FILING FEE RECEIVED</b> 12000	FEES: Authority has been given in Paper No. _____ to charge/credit DEPOSIT ACCOUNT No. _____ for following:		<input type="checkbox"/> All Fees <input type="checkbox"/> 1.16 Fees (Filing) <input type="checkbox"/> 1.17 Fees (Processing Ext. of time) <input type="checkbox"/> 1.18 Fees (Issue) <input type="checkbox"/> Other _____ <input type="checkbox"/> Credit			

Receipt date: 12/10/2014

Doc code: IDS

Doc description: Information Disclosure Statement (IDS) Filed

Under the Paperwork Reduction Act of 1995, no persons are required to respond to a collection of information unless it contains a valid OMB control number.

PTO/SB/06e (01-15)

Approved for use through 07/31/2012. OMB 0851-0031

U.S. Patent and Trademark Office; U.S. DEPARTMENT OF COMMERCE

<b>INFORMATION DISCLOSURE STATEMENT BY APPLICANT</b> (Not for submission under 37 CFR 1.98)	Application Number	90013252
	Filing Date	2014-05-22
	First Named Inventor	HARVEY SLEPIAN
	Art Unit	3992
	Examiner Name	England, David E.
	Attorney Docket Number	1089-001

U.S. PATENTS								
Examiner Initial*	Cite No	Patent Number	Kind Code <sup>1</sup>	Issue Date	Name of Patentee or Applicant of cited Document	Pages, Columns, Lines where Relevant Passages or Relevant Figures Appear		
	1							
If you wish to add additional U.S. Patent citation information please click the Add button.								
U.S. PATENT APPLICATION PUBLICATIONS								
Examiner Initial*	Cite No	Publication Number	Kind Code <sup>1</sup>	Publication Date	Name of Patentee or Applicant of cited Document	Pages, Columns, Lines where Relevant Passages or Relevant Figures Appear		
	1							
If you wish to add additional U.S. Published Application citation information please click the Add button.								
FOREIGN PATENT DOCUMENTS								
Examiner Initial*	Cite No	Foreign Document Number <sup>3</sup>	Country Code <sup>2</sup>	Kind Code <sup>4</sup>	Publication Date	Name of Patentee or Applicant of cited Document	Pages, Columns, Lines where Relevant Passages or Relevant Figures Appear	T <sup>5</sup>
	1							<input type="checkbox"/>
If you wish to add additional Foreign Patent Document citation information please click the Add button.								
NON-PATENT LITERATURE DOCUMENTS								
Examiner Initials*	Cite No	Include name of the author (in CAPITAL LETTERS), title of the article (when appropriate), title of the item (book, magazine, journal, serial, symposium, catalog, etc), date, pages(s), volume-issue number(s), publisher, city and/or country where published.						T <sup>5</sup>

ALL REFERENCES CONSIDERED EXCEPT WHERE LINED THROUGH. /DE/

SPS Web 2.1.17

/David England/

04/10/2015

Receipt date: 12/10/2014

<b>INFORMATION DISCLOSURE STATEMENT BY APPLICANT</b> ( Not for submission under 37 CFR 1.99)	Application Number	90013252
	Filing Date	2014-05-22
	First Named Inventor	HARVEY SLEPIAN
	Art Unit	3992
	Examiner Name	England, David E.
	Attorney Docket Number	

113	IPR2015-00276, Volkswagen Group of America, Inc. (Petitioner) v. Velocity Patent, LLC (Patent Owner), United States Patent and Trademark Office, Patent Trial and Appeal Board, Filing Date November 21, 2014	<input type="checkbox"/>
114	IPR2015-00290, Mercedes-Benz USA, LLC and Mercedes-Benz U.S. International, Inc. (Petitioner) v. Velocity Patent, LLC (Patent Owner), United States Patent and Trademark Office, Patent Trial and Appeal Board, Filing Date November 21, 2014	<input type="checkbox"/>

If you wish to add additional non-patent literature document citation information please click the Add button

**EXAMINER SIGNATURE**

Examiner Signature	/David England/	Date Considered	04/10/2015
--------------------	-----------------	-----------------	------------

\*EXAMINER: Initial if reference considered, whether or not citation is in conformance with MPEP 609. Draw line through a citation if not in conformance and not considered. Include copy of this form with next communication to applicant.

<sup>1</sup> See Kind Codes of USPTO Patent Documents at [www.USPTO.GOV](http://www.USPTO.GOV) or MPEP 901.04. <sup>2</sup> Enter office that issued the document, by the two-letter code (WIPO Standard ST.3). <sup>3</sup> For Japanese patent documents, the indication of the year of the reign of the Emperor must precede the serial number of the patent document. <sup>4</sup> Kind of document by the appropriate symbols as indicated on the document under WIPO Standard ST.16 if possible. <sup>5</sup> Applicant is to place a check mark here if English language translation is attached.

ALL REFERENCES CONSIDERED EXCEPT WHERE LINED THROUGH. /DE/

<b>Ex Parte Reexamination Interview Summary</b>	<b>Control No.</b> 90/013,252	<b>Patent Under Reexamination</b> 5,954,781
	<b>Examiner</b> DAVID ENGLAND	<b>Art Unit</b> 3992

All participants (USPTO personnel, patent owner, patent owner's representative):

(1) DAVID ENGLAND

(3) Michael Yigdal

(2) Jennifer McNeil

(4) Alisha Taylor Reg. No. 59332

Date of Interview: 02 April 2015

Type: a)  Telephonic b)  Video Conference  
c)  Personal (copy given to: 1)  patent owner 2)  patent owner's representative)

Exhibit shown or demonstration conducted: d)  Yes e)  No.  
If Yes, brief description: \_\_\_\_\_

Agreement with respect to the claims f)  was reached. g)  was not reached. h)  N/A.  
Any other agreement(s) are set forth below under "Description of the general nature of what was agreed to..."

Claim(s) discussed: 38,54,86-88,106 and 112.

Identification of prior art discussed: Rashid 5905457.

Description of the general nature of what was agreed to if an agreement was reached, or any other comments:  
See Continuation Sheet.

(A fuller description, if necessary, and a copy of the amendments which the examiner agreed would render the claims patentable, if available, must be attached. Also, where no copy of the amendments that would render the claims patentable is available, a summary thereof must be attached.)

**A FORMAL WRITTEN RESPONSE TO THE LAST OFFICE ACTION MUST INCLUDE PATENT OWNER'S STATEMENT OF THE SUBSTANCE OF THE INTERVIEW. (See MPEP § 2281). IF A RESPONSE TO THE LAST OFFICE ACTION HAS ALREADY BEEN FILED, THEN PATENT OWNER IS GIVEN **ONE MONTH** FROM THIS INTERVIEW DATE TO PROVIDE THE MANDATORY STATEMENT OF THE SUBSTANCE OF THE INTERVIEW (37 CFR 1.560(b)). THE REQUIREMENT FOR PATENT OWNER'S STATEMENT CAN NOT BE WAIVED. **EXTENSIONS OF TIME ARE GOVERNED BY 37 CFR 1.550(c).****

/DAVID ENGLAND/  
Primary Examiner, Art Unit 3992

cc: Requester (if third party requester)

Continuation of Description of the general nature of what was agreed to if an agreement was reached, or any other comments: Examiner England discussed ways to place the case in condition for allowance. First, claims 38, 54, 88, and 106 would have to have the typo deleted from the claims, "[means for mode selection]". Second, claims 86 and 87 did not include the claim language that was deemed allowable in the Non-Final Office Action and instead had the limitations of "further wherein... (i) and active mode..., and (ii) an inactive mode...". Examiner England stated that the prior art of Rashid 5905457 disclosed similar teachings and would be used to reject this new claim language if the allowable subject matter was not placed into the claim. Attorney Taylor agreed and stated that the Examiner make the necessary Examiner's amendments to place the claims in condition for allowance. Claim 112 had the claim language that was deemed allowable and would need to be canceled or be Objected to for not further limiting independent claim 86.



UNITED STATES PATENT AND TRADEMARK OFFICE

UNITED STATES DEPARTMENT OF COMMERCE  
United States Patent and Trademark Office  
Address: COMMISSIONER FOR PATENTS  
P.O. Box 1450  
Alexandria, Virginia 22313-1450  
www.uspto.gov

APPLICATION NO.	FILING DATE	FIRST NAMED INVENTOR	ATTORNEY DOCKET NO.	CONFIRMATION NO.
90/013,252	05/22/2014	5,954,781		9999

88360 7590 03/27/2015  
Richards Patent Law P.C.  
233 S. Wacker Dr., 84th Floor  
Chicago, IL 60606

EXAMINER

ENGLAND, DAVID E

ART UNIT	PAPER NUMBER
3992	

MAIL DATE	DELIVERY MODE
03/27/2015	PAPER

Please find below and/or attached an Office communication concerning this application or proceeding.

The time period for reply, if any, is set in the attached communication.



UNITED STATES PATENT AND TRADEMARK OFFICE

---

Commissioner for Patents  
United States Patents and Trademark Office  
P.O. Box 1450  
Alexandria, VA 22313-1450  
www.uspto.gov

THIRD PARTY REQUESTER'S CORRESPONDENCE ADDRESS

KENYON & KENYON LLP  
ONE BROADWAY  
NEW YORK, NY 10004

Date:

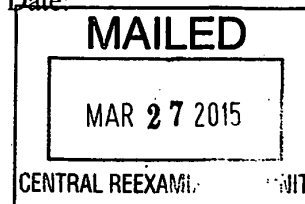

**EX PARTE REEXAMINATION COMMUNICATION TRANSMITTAL FORM**

REEXAMINATION CONTROL NO. : 90013252  
PATENT NO. : 5954781  
ART UNIT : 3993

Enclosed is a copy of the latest communication from the United States Patent and Trademark Office in the above identified ex parte reexamination proceeding (37 CFR 1.550(f)).

Where this copy is supplied after the reply by requester, 37 CFR 1.535, or the time for filing a reply has passed, no submission on behalf of the ex parte reexamination requester will be acknowledged or considered (37 CFR 1.550(g)).

---



<b>Transmittal of Communication to Third Party Requester <i>Inter Partes</i> Reexamination</b>	<b>Control No.</b>	<b>Patent Under Reexamination</b>	
	90/013,252	5,954,781	
	<b>Examiner</b>	<b>Art Unit</b>	
	David England	3992	

-- The MAILING DATE of this communication appears on the cover sheet with the correspondence address. --

(THIRD PARTY REQUESTER'S CORRESPONDENCE ADDRESS)

Kenyon and Kenyon LLP  
One Broadway  
New York, NY 10004

Enclosed is a copy of the latest communication from the United States Patent and Trademark Office in the above-identified reexamination proceeding. 37 CFR 1.903.

Prior to the filing of a Notice of Appeal, each time the patent owner responds to this communication, the third party requester of the *inter partes* reexamination may once file written comments within a period of 30 days from the date of service of the patent owner's response. This 30-day time period is statutory (35 U.S.C. 314(b)(2)), and, as such, it cannot be extended. See also 37 CFR 1.947.

If an *ex parte* reexamination has been merged with the *inter partes* reexamination, no responsive submission by any *ex parte* third party requester is permitted.

**All correspondence** relating to this *inter partes* reexamination proceeding should be directed to the **Central Reexamination Unit** at the mail, FAX, or hand-carry addresses given at the end of the communication enclosed with this transmittal.

**Decision Expunging/Returning  
Papers in Reexamination**

Control No.: 90/013,252

1.  THIS IS A DECISION EXPUNGING THE PAPERS FILED November 21<sup>st</sup> and 24<sup>th</sup>, 2014 by Third Party Requester from the record of the reexamination proceeding(s). Since each expunged paper does not form part of the record, it is being expunged by marking it "closed" and "not public" in the Office's Image File Wrapper (IFW) system.
- THIS IS A DECISION RETURNING/DESTROYING THE PAPER(S) FILED \_\_\_\_\_ by \_\_\_\_\_.

2. The papers being  expunged  returned  destroyed are:

Third Party Requester's 11/21/2014 submission of two documents cited as exhibits with Requester's "Notice of Concurrent Proceedings" document, including: (1) a corrected petition for *inter partes* review of U.S. Patent No. 5,954,781, and (2) a petition for *inter partes* review of U.S. Patent No 5,954,781 submitted 11/21/2014; and (3) a petition for *inter partes* review of US 5,954,781, and (4) the declaration of Dr. Chris Bartone in support of the petition for *inter partes* review, submitted 11/24/2014.

This decision will be made of record in the reexamination file(s).

3. THE ABOVE-IDENTIFIED PAPERS LACK A RIGHT OF ENTRY BECAUSE:
- A.  Patent Owner may not file papers in the record prior to the order granting/denying reexamination (*ex parte*) or first action (*inter partes*). 37 CFR §§1.530(a) and 1.939(b).
- B.  Third party requester in an *ex parte* reexamination may not file papers in the reexamination file subsequent to the request, except a reply to a proper patent owner statement under 37 CFR 1.530 or a *notice of concurrent proceedings* as described in MPEP 2282. See 37 CFR §§1.535 and 1.550(g).
- C.  Third party requester in an *inter partes* reexamination may not file papers in the record, except as specified in the rules, 37 CFR §§1.947, 1.951(b) and 1.983, and 37 CFR §§ 41.61-79, other than a notice of concurrent proceedings as described in MPEP 2686. See 37 CFR 1.939.
- D.  Parties other than patent owner and a third party requester may not file documents in the record except a notice of concurrent proceedings. See 37 CFR §§1.550(h) and 1.939(a).
- E.  The notice of concurrent proceedings exceeds the permitted scope. See MPEP 2282.
- F.  Other: Third Party Requester's 11/21/2014 submission of exhibits 1-4 noted above exceed the scope of the submissions permitted by MPEP 2282 and 37 CFR 1.565(a). While MPEP 2282 permits a Third Party Requester in an *ex parte* reexamination to appraise the Office of any litigation activity, or other prior or concurrent proceeding, involving the patent undergoing reexamination, pursuant to 37 CFR 1.565(a), that notification is limited to providing "bare notice". The submissions may not include arguments or information which provides a party's arguments (See MPEP 2282). The submission by Third Party Requester of the *inter partes* review petitions and supporting declaration is not limited to "bare notice" of concurrent proceedings. Thus, this submission does not comply with MPEP 2282 and 37 CFR 1.565(a). Accordingly, all of Third Party Requester's exhibits submitted with the Notice of Concurrent Proceedings documents filed 11/21/2014 and 11/24/2014 have been expunged from the record.

4. CONCLUSION

Telephone inquiries with regard to this decision should be directed to Jennifer McNeil at 571-272-1540, in the Central Reexamination Unit.

/Jennifer McNeil/  
[Signature]

SPE, Central Reexamination Unit  
(Title)

# Litigation Search Report CRU 3999

Reexam Control No. 90/013,252

<b>To: David England</b> <b>Location: CRU</b> <b>Art Unit: 3992</b> <b>Date: 03/23/2015</b>  <b>Case Serial Number: 90/013,252</b>	<b>From: Renee Preston</b> <b>Location: CRU 3999</b> <b>MDE 4B15</b> <b>Phone: (571) 272-1607</b>  <b>Renee.preston@uspto.gov</b>
---	--

## Search Notes

U.S. Patent No. 5,954,781

- 1) I performed a KeyCite Search in Westlaw, which retrieves all history on the patent including any litigation.
- 2) I performed a search on the patent in Lexis CourtLink for any open dockets or closed cases.
- 3) I performed a search in Lexis in the Federal Courts and Administrative Materials databases for any cases found.
- 4) I performed a search in Lexis in the IP Journal and Periodicals database for any articles on the patent.
- 5) I performed a search in Lexis in the news databases for any articles about the patent or any articles about litigation on this patent.

Litigation found

Closed	Docket Number	Description	Court
N/A	IPR2015-00276	Volkswagen Group of America, Inc. vs. Velocity Patent LLC	US-DIS-ALE
N/A	IPR2015-00290	Mercedes-Benz USA, LLC vs. Velocity Patent, LLC	US-DIS-ALE
N/A	IPR2014-01247	Mercedes-Benz USA, LLC vs. Velocity Patent, LLC	US-DIS-ALE
No	1:13cv8413	Velocity Patent LLC v. Mercedes-Benz USA, LLC et al	US-DIS-ILND
Yes	1:13cv8416	Velocity Patent LLC v. BMW of North America, LLC et al	US-DIS-ILND
No	1:13cv8418	Velocity Patent LLC v. Audi of America, Inc. et al	US-DIS-ILND
No	1:13cv8419	Velocity Patent LLC v. Chrysler Group, LLC	US-DIS-ILND
Yes	1:13cv8421	Velocity Patent LLC v. Jaguar Land Rover North America, LLC	US-DIS-ILND

**KEYCITE**

**© US PAT 5954781 METHOD AND APPARATUS FOR OPTIMIZING VEHICLE OPERATION, Assignee: TAS Distributing Co., Inc. (Sep 21, 1999)**

**History****Direct History**

=> 1 **METHOD AND APPARATUS FOR OPTIMIZING VEHICLE OPERATION, US PAT 5954781, 1999 WL 1737468 (U.S. PTO Utility Sep 21, 1999)**

**Patent Family**

.. **VEHICLE OPERATION OPTIMIZING APPARATUS, Derwent World Patents Legal 1999-539495**

**Assignments**

3 **Action: ASSIGNMENT OF ASSIGNORS INTEREST (SEE DOCUMENT FOR DETAILS). Number of Pages: 005, (DATE RECORDED: Nov 20, 2013)**  
 4 **Action: ASSIGNMENT OF ASSIGNORS INTEREST (SEE DOCUMENT FOR DETAILS). Number of Pages: 004, (DATE RECORDED: Nov 20, 2013)**  
 5 **ASSIGNEE(S): TAS DISTRIBUTING CO., INC., (DATE RECORDED: Mar 10, 1997)**

**Patent Status Files**

.. **Disclaimer, (OG DATE: Feb 24, 2015)**  
 .. **AIA Trial Proceedings Filed before The Patent Trial and Appeal Board, (OG DATE: Jan 06, 2015)**  
 .. **AIA Trial Proceedings Filed before The Patent Trial and Appeal Board, (OG DATE: Jan 06, 2015)**  
 .. **AIA Trial Proceedings Filed before The Patent Trial and Appeal Board, (OG DATE: Sep 16, 2014)**  
 .. **AIA Trial Proceedings Filed before The Patent Trial and Appeal Board, (OG DATE: Sep 16, 2014)**  
 .. **Request for Re-Examination, (OG DATE: Jul 29, 2014)**  
 .. **Patent Suit(See LitAlert Entries),**

**Docket Summaries**

13 **VELOCITY PATENT LLC v. AUDI OF AMERICA, INC. ET AL., (N.D.ILL. Nov 21, 2013) (NO. 1:13CV08418), (35 USC 271 PATENT INFRINGEMENT)**

- 14 VELOCITY PATENT LLC v. BMW OF NORTH AMERICA, LLC ET AL, (N.D.ILL. Nov 21, 2013) (NO. 1:13CV08416), (35 USC 271 PATENT INFRINGEMENT)
- 15 VELOCITY PATENT LLC v. JAGUAR LAND ROVER NORTH AMERICA, LLC, (N.D.ILL. Nov 21, 2013) (NO. 1:13CV08421), (35 USC 271 PATENT INFRINGEMENT)
- 16 VELOCITY PATENT LLC v. MERCEDES-BENZ USA, LLC ET AL, (N.D.ILL. Nov 21, 2013) (NO. 1:13CV08413), (35 USC 271 PATENT INFRINGEMENT)
- 17 VELOCITY PATENT LLC v. CHRYSLER GROUP, LLC, (N.D.ILL. Nov 21, 2013) (NO. 1:13CV08419), (35 USC 271 PATENT INFRINGEMENT)

**Litigation Alert**

- 18 Derwent LitAlert P2013-49-10 (Nov 21, 2013) Action Taken: CAUSE - 35 USC 271 - COMPLAINT FOR PATENT INFRINGEMENT
- 19 Derwent LitAlert P2013-49-11 (Nov 21, 2013) Action Taken: CAUSE - 35 USC 271 - COMPLAINT FOR PATENT INFRINGEMENT
- 20 Derwent LitAlert P2013-49-12 (Nov 21, 2013) Action Taken: CAUSE - 35 USC 271 - COMPLAINT FOR PATENT INFRINGEMENT
- 21 Derwent LitAlert P2013-49-13 (Nov 21, 2013) Action Taken: CAUSE - 35 USC 271 - COMPLAINT FOR PATENT INFRINGEMENT
- 22 Derwent LitAlert P2013-49-14 (Nov 21, 2013) Action Taken: CAUSE - 35 USC 271 - COMPLAINT FOR PATENT INFRINGEMENT

**Prior Art (Coverage Begins 1976)**

- © 23 AUTOMATIC BRAKE CONTROL SYSTEM, US PAT 5420792Assignee: Mazda Motor Corporation, (U.S. PTO Utility 1995)
- © 24 DRIVING AID INDICATOR FOR ECONOMICAL OPERATION OF AUTOMATIC TRANSMISSION EQUIPPED MOTOR VEHICLE, US PAT 4542460 (U.S. PTO Utility 1985)
- © 25 METHOD AND DEVICE FOR SIGNALING THAT GEAR CHANGE IS REQUIRED, US PAT 4701852Assignee: AB Volvo, (U.S. PTO Utility 1987)
- © 26 METHOD FOR DIRECTING AN UP-SHIFT OPERATION FOR A VEHICLE HAVING A MANUAL TRANSMISSION, US PAT 4752883Assignee: Honda Giken Kogyo Kabushiki Kaisha, (U.S. PTO Utility 1988)
- © 27 METHOD OF INDICATING A SHIFT OPERATION OF A MANUAL TRANSMISSION GEAR OF A VEHICLE, US PAT 4868756Assignee: Honda Giken Kogyo Kabushiki Kaisha, (U.S. PTO Utility 1989)
- © 28 OPTIMUM SHIFT POSITION INDICATING DEVICE OF VEHICLE, US PAT 4492112Assignee: Toyota Jidosha Kabushiki Kaisha, (U.S. PTO Utility 1985)
- © 29 SHIFT INDICATOR SYSTEM FOR VEHICLE, US PAT 4853673Assignee: Mazda Motor Corporation, (U.S. PTO Utility 1989)
- © 30 TRAVELING-PATH PREDICTION APPARATUS AND METHOD FOR VEHICLES, US PAT 5745870Assignee: Mazda Motor Corporation, (U.S. PTO Utility 1998)
- © 31 TWO-CYCLE ENGINE WITH ELECTRONIC FUEL INJECTION, US PAT 4901701Assignee:

Injection Research Specialists, Inc., (U.S. PTO Utility 1990)

- © 32 VALVED SACK, US PAT 4524460 Assignee: Windmoller & Holscher, (U.S. PTO Utility 1985)
- © 33 VEHICLE GEAR SHIFT INDICATOR, US PAT 4631515 Assignee: AE PLC, (U.S. PTO Utility 1986)
- © 34 VEHICLE RUNNING MODE DETECTING SYSTEM, US PAT 5708584 Assignee: Mazda Motor Corporation, (U.S. PTO Utility 1998)



1 of 1 DOCUMENT

UNITED STATES PATENT AND TRADEMARK OFFICE GRANTED PATENT

5954781

[Link to Claims Section](#)

September 21, 1999

Method and apparatus for optimizing vehicle operation

**REEXAM-LITIGATE:**

Reexamination requested May 22, 2014 by Volkswagen Group of America, Inc., Clifford A. Ulrich, Kenyon & Kenyon, LLP., New York, NY, Reexamination No. 90/013,252 (O.G. July 29, 2014) Ex. Gp.: 3992 May 22, 2014

NOTICE OF LITIGATION

Velocity Patent LLC v. Mercedes-Benz Usa, LLC et al, Filed November 21, 2013, D.C. N.D. Illinois, Doc. No. 1:13cv8413

NOTICE OF LITIGATION

Velocity Patent LLC v. Bmw Of North America, LLC et al, Filed November 21, 2013, D.C. N.D. Illinois, Doc. No. 1:13cv8416

NOTICE OF LITIGATION

Velocity Patent LLC v. Audi Of America, Inc. et al, Filed November 21, 2013, D.C. N.D. Illinois, Doc. No. 1:13cv8418

NOTICE OF LITIGATION

Velocity Patent LLC v. Chrysler Group, LLC, Filed November 21, 2013, D.C. N.D. Illinois, Doc. No. 1:13cv8419

NOTICE OF LITIGATION

Velocity Patent LLC v. Jaguar Land Rover North America, LLC, Filed November 21, 2013, D.C. N.D. Illinois, Doc. No. 1:13cv8421

813270 (08) 5954781 September 21, 1999

**INVENTOR:** SLEPIAN HARVEY - ; SUTTON LORAN -

**DISCLAIMER-DATE:**

December 10, 2014 - Disclaimer filed by the inventors. Hereby disclaim complete claims 31 and 32, of said patent.  
(O.G. February 24, 2015)

**APPL-NO:** 813270 (08)

**FILED-DATE:** March 10, 1997

**GRANTED-DATE:** September 21, 1999

**PRIORITY:** March 10, 1997 - 08813270, United States of America (US)

**ASSIGNEE-PRE-ISSUE:**

March 10, 1997 - ASSIGNMENT OF ASSIGNORS INTEREST (SEE DOCUMENT FOR DETAILS), TAS DISTRIBUTING CO., INC., 806 W. PIONEER PARKWAY, PEORIA, ILLINOIS, UNITED STATES OF AMERICA (US), 61615, Reel and Frame Number: 008435/0064

**ASSIGNEE-AT-ISSUE:**

TAS DISTRIBUTING CO INC, United States of America (US)

**ASSIGNEE-AFTER-ISSUE:**

November 20, 2013 - ASSIGNMENT OF ASSIGNORS INTEREST (SEE DOCUMENT FOR DETAILS), VELOCITY PATENTS LLC, SUITE 2900, 350 N. ST. PAUL STREET, DALLAS, TEXAS, UNITED STATES OF AMERICA (US), 75201, Reel and Frame Number: 031635/0364

November 20, 2013 - ASSIGNMENT OF ASSIGNORS INTEREST (SEE DOCUMENT FOR DETAILS), VELOCITY PATENT LLC, 335 LLOYDEN PARK LANE, ATHERTON, CALIFORNIA, UNITED STATES OF AMERICA (US), 94027, Reel and Frame Number: 031635/0376

**LEGAL-REP:** Haynes and Boone, LLP

**PUB-TYPE:** September 21, 1999 - Patent (A)

**PUB-COUNTRY:** United States of America (US)

**LEGAL-STATUS:**

March 10, 1997 - ASSIGNMENT

April 9, 2003 - MAINTENANCE FEE REMINDER MAILED

September 22, 2003 - FEE PAYMENT

September 22, 2003 - SURCHARGE FOR LATE PAYMENT

April 11, 2007 - MAINTENANCE FEE REMINDER MAILED

September 17, 2007 - FEE PAYMENT

September 17, 2007 - SURCHARGE FOR LATE PAYMENT

April 25, 2011 - MAINTENANCE FEE REMINDER MAILED

August 17, 2011 - FEE PAYMENT

August 17, 2011 - SURCHARGE FOR LATE PAYMENT

November 20, 2013 - ASSIGNMENT

November 20, 2013 - ASSIGNMENT



813270 (08) 5954781 September 21, 1999

July 29, 2014 - REQUEST FOR REEXAMINATION FILED  
 September 16, 2014 - AIA TRIAL PROCEEDING FILED BEFORE THE PATENT AND APPEAL BOARD: INTER PARTES REVIEW  
 January 6, 2015 - AIA TRIAL PROCEEDING FILED BEFORE THE PATENT AND APPEAL BOARD: INTER PARTES REVIEW  
 January 6, 2015 - AIA TRIAL PROCEEDING FILED BEFORE THE PATENT AND APPEAL BOARD: INTER PARTES REVIEW  
 February 24, 2015 - DISCLAIMER FILED  
 June 4, 2001 - Payor Number Assigned.  
 April 9, 2003 - Maintenance Fee Reminder Mailed.  
 September 22, 2003 - Surcharge for late Payment, Small Entity.  
 September 22, 2003 - Payment of Maintenance Fee, 4th Yr, Small Entity.  
 April 11, 2007 - Maintenance Fee Reminder Mailed.  
 September 17, 2007 - 7.5 yr surcharge - late pmt w/in 6 mo, Small Entity.  
 September 17, 2007 - Payment of Maintenance Fee, 8th Yr, Small Entity.  
 April 25, 2011 - Maintenance Fee Reminder Mailed.  
 August 17, 2011 - 11.5 yr surcharge- late pmt w/in 6 mo, Small Entity.  
 August 17, 2011 - Payment of Maintenance Fee, 12th Yr, Small Entity.

**FILING-LANG:** English (EN) (ENG)

**PUB-LANG:** English (EN) (ENG)

**US-MAIN-CL:** 701#96

**US-ADDL-CL:** 340#425.5, 340#438, 701#103

**CL:** 701, 340

**IPC-MAIN-CL:** [6] G06F 007#00

**IPC-MAIN-CL:** [8] B60K 028#00 (20060101) Advanced Inventive 20051008 (A I R M EP)

**IPC-ADDL-CL:** [8] B60R 016#02 (20060101) Advanced Inventive 20051008 (A I R M EP)

**IPC-ADDL-CL:** [8] B60R 016#23 (20060101) Advanced Inventive 20070721 (A I R M EP)

**IPC-ADDL-CL:** [8] B60W 050#14 (20120101) Advanced Non-Inventive 20150218 (A N R M EP)

**IPC-ADDL-CL:** [8] F16H 059#74 (20060101) Advanced Non-Inventive 20051008 (A N R M EP)

**PRIM-EXMR:** Cuchlinski, Jr., William A.

**ASST-EXMR:** Arthur; Gertrude

**REF-CITED:**

4492112, January 8, 1985, IGARASHI KOUHEI [JP], et al, United States of America (US)  
 4542460, September 17, 1985, WEBER HAROLD J [US], United States of America (US)  
 4631515, December 23, 1986, BLEE TIMOTHY J [GB], et al, United States of America (US)

813270 (08) 5954781 September 21, 1999

4701852, October 20, 1987, ULVELAND STEFAN [SE], United States of America (US)  
4752883, June 21, 1988, ASAKURA MASAHICO [JP], et al, United States of America (US)  
4853673, August 1, 1989, KIDO YOSHINOBU [JP], et al, United States of America (US)  
4868756, September 19, 1989, KAWANABE TOMOHIKO [JP], et al, United States of America (US)  
4901701, February 20, 1990, CHASTEEN RONALD E [US], United States of America (US)  
5420792, May 30, 1995, BUTSUEN TETSURO [JP], et al, United States of America (US)  
5708584, January 13, 1998, DOI AYUMU [JP], et al, United States of America (US)  
5745870, April 28, 1998, YAMAMOTO YASUNORI [JP], et al, United States of America (US)

**ENGLISH-ABST:**

Apparatus for optimizing operation of an engine-driven vehicle. The apparatus includes a processor subsystem, a memory subsystem, a road speed sensor, an engine speed sensor, a manifold pressure sensor, a throttle position sensor, a radar detector for determining the distance separating the vehicle from an object in front of it, a windshield wiper sensor for indicating whether a windshield wiper of the vehicle is activated, a brake sensor for determining whether the brakes of the vehicle have been activated, a fuel overinjection notification circuit for issuing notifications that excessive fuel is being supplied to the engine of the vehicle, an upshift notification circuit for issuing notifications that the engine of the vehicle is being operated at an excessive engine speed, a downshift notification circuit for issuing notifications that the engine of the vehicle is being operated at an insufficient engine speed, a vehicle proximity alarm circuit for issuing an alarm that the vehicle is too close to an object in front of the vehicle and a throttle controller for automatically reducing the amount of fuel supplied to the engine if the vehicle is too close to the object in front of it. Based upon data received from the sensors and data stored in the memory subsystem, the processor determines whether to activate the fuel overinjection notification circuit, the upshift notification circuit, the downshift notification circuit, the vehicle proximity alarm circuit or the throttle controller.

**NO-OF-CLAIMS:** 32**NO-OF-FIGURES:** 3**NO-DRWNG-PP:** 3**SUMMARY:**

## 1. Field of the Invention

The present invention generally relates to an apparatus for optimizing vehicle operation and, more particularly, relates to a system which both notifies the driver of recommended corrections in vehicle operation and, under certain conditions, automatically initiates selected corrective action.

## 2. Description of Related Art

It has long been recognized that the improper operation of a vehicle may have many adverse effects. For example, the fuel efficiency of a vehicle may vary dramatically based upon how the vehicle is operated. More specifically, operating a vehicle at excessive speed, excessive RPM and/or excessive manifold pressure will result in both reduced fuel economy and increased operating costs. The aforementioned increased operating costs can be quite considerable, particularly for an owner or operator of a fleet of vehicles. To correct these types of improper vehicle operations are often surprisingly simple. For example, upshifting the drive gear will typically eliminate an excessive RPM condition. However, even when the solution is quite simple, oftentimes, the driver will be unaware of the need to take corrective action.

A variety of patents have disclosed systems, commonly referred to as "shift prompters", which monitor the operation of a vehicle and advises the operator of the vehicle when to take certain actions. Numerous ones of these devices include sensors which measure engine speed and vehicle speed. See, for example, U.S. Pat. No. 4,492,112 to Igarashi et al., U.S. Pat. No. 4,631,515 to Blee et al. and U.S. Pat. No. 4,701,852 to Ulveland. Certain ones, however, disclose the use of other types of sensors as well. For example, U.S. Pat. No. 4,524,460 to Weber is directed to a driving aid indicator which includes vehicle speed, manifold pressure, throttle position and engine speed sensors. U.S. Pat. No. 4,752,883 to Asakura et al. and U.S. Pat. No. 4,868,756 to Kawanabe et al. are directed to upshift notification devices which include sensors for measuring engine speed, vehicle speed, manifold pressure and cooling water temperature. Finally, U.S. Pat. No. 4,853,673 to Kido et al. discloses a shift indicator system which includes sensors for measuring engine speed and throttle position. Generally, the above-listed patents all provide displays intended to enable the driver to operate the vehicle in a manner leading to uniform performance and maximum fuel economy. However, Blee et al. discloses the use of audible warnings as well as a speed controller to prevent further increases in engine speed if the driver ignores previously issued warnings.

Improper vehicle operation has other adverse effects as well. It is well known that the faster a vehicle travels, the longer it takes to stop. Thus, what may be a safe separation distance between successive vehicles when a vehicle is traveling at 35 mph may be unsafe if that vehicle is traveling at 50 mph. Road conditions also play a role in determining the safe separation distance between vehicles. For example, greater separation distances are generally recommended when roads are wet. As a result, therefore, based on the combination of a vehicle's speed, the distance separating the vehicle from a second vehicle in front of it and road conditions, many vehicles are operated unsafely. To correct this situation, a reduction in operating speed, an increase in vehicle separation or some combination thereof, is required.

It may be readily seen from the foregoing that it would be desirable to provide a system which integrates the ability to issue audible warnings which advise the driver to correct operation of the vehicle in a manner which will enhance the efficient operation thereof with the ability to automatically take corrective action if the vehicle is being operated unsafely. It is, therefore, the object of the invention to provide such a system.

In one embodiment, the present invention is directed to an apparatus for optimizing operation of an engine-driven vehicle. The apparatus includes a processor subsystem, a memory subsystem, plural sensors, including road speed, manifold pressure and throttle position sensors, for collectively monitoring operation of the vehicle and a fuel overinjection notification circuit for issuing notifications that excessive fuel is being supplied to the engine of the vehicle. The processor subsystem receives data from the sensors and, from the received data, determines when to activate the fuel overinjection circuit. In one aspect thereof, the processor subsystem determines when road speed for the vehicle is increasing, determines when throttle position for the vehicle is increasing, compares manifold pressure and a manifold pressure set point stored in the memory subsystem and activates the fuel overinjection notification circuit if both road speed and throttle position for the vehicle are increasing and manifold pressure for the vehicle is above the manifold pressure set point.

In further aspects thereof, the sensors may include an engine speed sensor and the processor subsystem may determine when road speed for the vehicle is decreasing, when throttle position for the vehicle is increasing, when manifold pressure for the vehicle is increasing, when engine speed for the vehicle is decreasing and may activate the fuel overinjection notification circuit if both throttle position and manifold pressure for the vehicle are increasing and road speed and engine speed for the vehicle are decreasing.

In still further aspects thereof, the apparatus may also include an upshift notification circuit, activated by the processor subsystem based upon data received from the sensors, which issues notifications that the engine of the vehicle is being operated at excessive engine speeds. In this aspect, the processor subsystem determines when road speed for the vehicle is increasing, when throttle position for the vehicle is increasing, compares manifold pressure to a manifold pressure set point stored in the memory subsystem, compares engine speed to an RPM set point stored in the memory subsystem and activates the upshift notification circuit if both road speed and throttle position for the vehicle are increasing, manifold pressure for the vehicle is at or below the manifold pressure set point and engine speed for the

vehicle is at or above the RPM set point.

In still yet further aspects thereof, the apparatus may also include a downshift notification circuit, activated by the processor subsystem based upon data received from the sensors, which issues a notification that the engine of the vehicle is being operated at an insufficient engine speed. The processor subsystem may determine when road speed for the vehicle is decreasing, when throttle position for the vehicle is increasing, when manifold pressure for the vehicle is increasing, when engine speed for the vehicle is decreasing and may activate the downshift notification circuit if both road speed and engine speed are decreasing and both throttle position and manifold pressure for the vehicle are increasing.

In still further aspects thereof, the fuel overinjection circuit, the upshift notification circuit or the downshift notification circuit may include a horn for issuing a tone for a preselected time period.

In another embodiment, the present invention is of an apparatus for optimizing operation of a vehicle. The apparatus includes road speed, engine speed, manifold pressure and throttle position sensors, a processor subsystem coupled to each of the sensors to receive data therefrom and a memory subsystem, coupled to the processor subsystem, for storing a manifold pressure set point, an engine speed set point and present and prior levels for each one of the sensors. The apparatus further includes a fuel overinjection notification circuit, an upshift notification circuit and a downshift notification circuit, all of which are coupled to the processor subsystem. The fuel overinjection notification circuit issues notifications that excessive fuel is being supplied to the engine of the vehicle, the upshift notification circuit issues notifications that the engine of the vehicle is being operated at an excessive engine speed and the downshift notification circuit issues notifications that the engine of the vehicle is being operated at an insufficient engine speed. Based upon data received from the sensors, the processor subsystem determines when to activate the fuel overinjection circuit, the upshift notification circuit and the downshift notification circuit. In one aspect thereof, the fuel overinjection circuit includes a first horn for issuing a first tone for a first preselected time period, the upshift notification circuit includes a second horn for issuing a second tone for a second preselected time period and the downshift notification circuit includes a third horn for issuing a third tone for a third preselected time period.

In another aspect thereof, the processor subsystem may determine when road speed for the vehicle is increasing or decreasing, engine speed is increasing or decreasing, throttle position for the vehicle is increasing and manifold pressure is increasing; may compare manifold pressure to the manifold pressure set point and engine speed to the RPM set point; and may activate the fuel overinjection notification circuit if both road speed and throttle position for the vehicle are increasing and manifold pressure for the vehicle is above the manifold pressure set point or if both throttle position and manifold pressure for the vehicle are increasing and road speed and engine speed for the vehicle are decreasing, the upshift notification circuit if both road speed and throttle position for the vehicle are increasing, manifold pressure for the vehicle is at or below the manifold pressure set point and engine speed for the vehicle is at or above the RPM set point and the downshift notification circuit if both road speed and engine speed are decreasing and both throttle position and manifold pressure for the vehicle are increasing.

In another aspect, the present invention is of an apparatus for optimizing operation of a vehicle which includes a radar detector for determining a distance separating a vehicle having an engine and an object in front of the vehicle and at least one sensor for monitoring operation of the vehicle. The apparatus further includes a processor subsystem, a memory subsystem and a vehicle proximity alarm circuit. The processor subsystem is coupled to the radar detector and the at least one sensor to receive data therefrom while the memory subsystem, in which a first vehicle speed/stopping distance table and present levels for each one of the at least one sensor are stored, and the vehicle proximity alarm circuit are coupled to the processor subsystem. Based on data received from the radar detector, the at least one sensor and the contents of the memory subsystem, the processor determines when to instruct the vehicle proximity alarm circuit to issue an alarm that the vehicle is too close to the object.

In one aspect thereof, the at least one sensor further includes a windshield wiper sensor for indicating whether a windshield wiper of the vehicle is activated and a second vehicle speed/stopping distance table is stored in the memory

subsystem. In another aspect thereof, the apparatus further includes a throttle controller for controlling a throttle of the engine of the vehicle. The processor subsystem may selectively reduce the throttle based upon data received from the radar detector, the at least one sensor and the memory subsystem or may also count a total number of vehicle proximity alarms determined by the processor subsystem and selectively reduce the throttle based upon the total number of vehicle proximity alarms, as well. In yet another aspect thereof, the at least one sensor further includes a brake sensor for indicating whether a brake system of the vehicle is activated.

In other aspects thereof, the apparatus may be further provided with a fuel overinjection notification circuit for issuing a notification that excessive fuel is being supplied to the engine of the vehicle, an upshift notification circuit for issuing a notification that the engine of the vehicle is being operated at an excessive engine speed or a downshift notification circuit for issuing a notification that the engine of the vehicle is being operated at an insufficient engine speed. If a fuel overinjection notification circuit is provided, the apparatus includes a manifold pressure sensor and a throttle position sensor which also provide the processor subsystem with data used, together with a manifold pressure set point and prior levels for the sensors stored in the memory subsystem, to determine when to activate the fuel overinjection circuit. If an upshift notification circuit is provided, the apparatus includes an engine speed sensor which also provides the processor subsystem with data used, together with an RPM set point stored in the memory subsystem, to determine when to activate the upshift notification circuit. Finally, if a downshift notification circuit is provided, the processor subsystem determines when to activate the downshift notification circuit based upon the data received from the plurality of sensors.

In still another embodiment, the present invention is of an apparatus for optimizing operation of a vehicle which includes a radar detector for determining a distance separating the vehicle from an object in front of it, a plurality of sensors, including a road speed sensor, an engine speed sensor, a manifold pressure sensor and a throttle position sensor, which collectively monitor the operation of the vehicle, a processor subsystem, a memory subsystem, a fuel overinjection notification circuit for issuing notification that excessive fuel is being supplied to the engine of the vehicle and a vehicle proximity alarm circuit for issuing alarms if the vehicle is too close to the object. Based upon data received from the sensors, the processor subsystem determines when to activate the fuel overinjection circuit. Based upon data received from the radar detector, the sensors and the memory subsystem, the processor subsystem also determines when to activate the vehicle proximity alarm circuit.

In one aspect of this embodiment of the invention, the processor subsystem determines when road speed for the vehicle is increasing or decreasing, when throttle position for the vehicle is increasing or decreasing, compares manifold pressure to a manifold pressure set point stored in the memory subsystem, determines when manifold pressure for the vehicle is increasing or decreasing and determines when engine speed for the vehicle is increasing or decreasing. In this aspect, the processor subsystem activates the fuel overinjection notification circuit if both road speed and throttle position for the vehicle are increasing and manifold pressure for the vehicle is above the manifold pressure set point or if both throttle position and manifold pressure for the vehicle are increasing and road speed and engine speed for the vehicle are decreasing.

In a further aspect thereof, the apparatus may also include an upshift notification circuit for issuing notifications that the engine of the vehicle is being operated at an excessive engine speed, the processor subsystem determining when to activate the upshift notification circuit based upon data received from the sensors. In a related aspect thereof, the processor subsystem determines when road speed for the vehicle is increasing, determines when throttle position for the vehicle is increasing, compares manifold pressure to a manifold pressure set point stored in the memory subsystem and compares engine speed to an RPM set point stored in the memory subsystem. In this aspect, the processor subsystem activates the upshift notification circuit if both road speed and throttle position for the vehicle are increasing, manifold pressure for the vehicle is at or below the manifold pressure set point and engine speed for the vehicle is at or above the RPM set point.

In still another aspect thereof, the apparatus may also include a downshift notification circuit for issuing a notification that the engine of the vehicle is being operated at an insufficient engine speed. In this aspect, the processor

813270 (08) 5954781 September 21, 1999

subsystem determines when to activate the downshift notification circuit based upon data received from the sensors. In a related aspect thereof, the processor subsystem determines when road speed for the vehicle is decreasing, determines when throttle position for the vehicle is increasing, determines when manifold pressure for the vehicle is increasing and determines when engine speed for the vehicle is decreasing. In this aspect, the processor subsystem activates the downshift notification circuit if both road speed and engine speed are decreasing and both throttle position and manifold pressure for the vehicle are increasing.

**DRWDESC:****BRIEF DESCRIPTION OF THE DRAWINGS**

The present invention may be better understood, and its numerous objects, features and advantages will become apparent to those skilled in the art by reference to the accompanying drawing, in which:

FIG. 1 is a block diagram of an apparatus for optimizing vehicle performance constructed in accordance with the teachings of the present invention; and

FIGS. 2A-B is a flow chart of a method for optimizing vehicle performance in accordance with the teachings of the present invention.

**DETDESC:****DETAILED DESCRIPTION**

Referring first to FIG. 1, a system 10 for optimizing vehicle performance constructed in accordance with the teachings of the present invention will now be described in greater detail. The system 10 includes a processor subsystem 12, for example, a microprocessor, and a memory subsystem 14, for example, the memory subsystem 14 may include a nonvolatile random access memory (or "NVRAM"), coupled together by a bus 16 for bi-directional exchanges of address, data and control signals therebetween. The system 10 is installed in a vehicle (not shown) for which optimized performance and driver assist capabilities are desired. Although it is contemplated that the system 10 is suitable for use with any type vehicle, most commonly, the system 10 shall be installed in a truck.

Also coupled to the processor subsystem 12 are a series of sensors, each of which are periodically polled by the processor subsystem 12, to determine the respective states or levels thereof. The sensors include a road speed sensor 18, an RPM sensor 20, a manifold pressure sensor 22, a throttle sensor 24, a windshield wiper sensor 30 and a brake sensor 32. The sensors are selected to be either state or level sensors, depending on whether the information to be collected thereby is a state, i.e., on/off or a level, for example, 35 mph. The road speed sensor 18 and the RPM sensor 20 are level sensors which respectively provide the processor subsystem 12 with signals which indicate the operating speed and engine speed for the vehicle. The road speed sensor 18 and the RPM sensor 20 may derive such information from any one of a variety of sources. For example, the road speed sensor 18 may be connected to receive the speed input signal transmitted to the vehicle's speedometer while the RPM sensor 20 may be connected to receive the RPM input signal to the vehicle's tachometer.

The manifold pressure sensor 22 is a level sensor which is positioned downstream of the throttle valve in the intake manifold of the vehicle to measure manifold pressure thereat. The throttle sensor 24 is a level sensor, attached to the throttle, which measures the extent to which the throttle is opened. The windshield wiper sensor 30 is a state sensor which determines whether the vehicle's windshield wipers are on or off. In alternate embodiments thereof, the windshield wiper sensor 30 may be electrically coupled to the on/off switch for the windshield wiper or to an output of

the windshield wiper motor. Finally, the brake sensor 32 is a state sensor which determines whether the brakes of the vehicle have been engaged. For example, the brake sensor 32 may be electrically coupled to the brake system to detect the activation thereof.

Preferably, the memory subsystem 14 should include first and second registers 14a and 14b, each having sufficient bits for holding the state/level of each of the sensors 18, 20, 22, 24, 30 and 32. The first register 14a is used to hold the present state or level of each of the sensors 18, 20, 22, 24, 30 and 32 while the second register 14b is used to hold the prior state or level for each of the sensors 18, 20, 22, 24, 30 and 32. Each time the processor subsystem 12 writes the present state or level of the sensors 18, 20, 22, 24, 30 and 32 to the first register 14a, the prior contents of the first register 14a is written to the second register 14b which, in turn, discards the prior content thereof. The memory subsystem 14 is also used to hold information to be utilized by the processor subsystem 12 to determining whether to take corrective actions and/or issue notifications. Typically, such information is placed in the memory subsystem 14 while the system 10 is being initialized. The information includes one or more speed/distance tables which, when used in a manner which will be more fully described below in combination with data collected by the system 10, enable the processor subsystem 12 to determine if the vehicle is being operated unsafely and if corrective action is necessary. Speed/stopping distance table. The information also includes two pre-set threshold values--a manifold psi set point and an engine RPM set point. As will also be more fully described below, the processor subsystem 12 uses these threshold values to determine when to issue notifications as to recommended changes in vehicle operation which, when executed by the driver, will optimize vehicle operation. The speed/stopping distance table(s) are based upon National Safety Council guidelines, vary according to the class of the vehicle and provide the relationship between the speed at which a vehicle is travelling and the distance which the vehicle will require to come to a complete stop if travelling at that speed. The manifold psi set point and RPM set point are selected based upon the manufacturer's guidelines for proper operation of the vehicle, vary based upon horsepower and engine size for the vehicle and represent thresholds above which the manifold pressure and engine rotation speed, respectively, for the vehicle should never exceed.

The system 10 also includes a throttle controller 26 capable of opening and/or closing the throttle, a radar detector 28 positioned to determine the distance separating the vehicle and an object in front of the vehicle, for example, a second vehicle travelling in the same direction, a series of circuits 34, 36, 38 and 40 for notifying the driver of the vehicle of recommended corrections in vehicle operation and alerting the driver to unsafe operating conditions and a power supply, for example a +12 v battery, for providing power to the energy-demanding components of the system 10. The circuits 34, 36, 38 and 40 include an upshift notification circuit 34 for notifying the driver that an upshift is recommended, a downshift notification circuit 36 for notifying the driver that a downshift is recommended, an overinjection notification circuit 38 for notifying the driver that too much fuel is being supplied to the vehicle and a vehicle proximity alarm circuit 40 for alerting the driver when an object in front of the vehicle is too close. The circuits 34, 36 and 38 may be configured to provide visual and/or audible notifications, for example, using lights and/or horns. For example, the upshift circuit 34, the downshift notification circuit 36 and the overinjection notification circuit 38 may each include a horn, or other tone generating device, from which an audible notification may be generated at a selected pitch. Preferably, each of the notification circuits 34, 36 and 38 may be configured to provide distinct audible notifications, for example, tones at distinct pitches, so that the driver may readily distinguish which of the notification circuits 34, 36 and 38 have been activated by the processor subsystem 12. The proximity alarm circuit 40 may include one or more visual and/or audible warning devices such as lights and/or horns. For example, the proximity alarm circuit 40 may include a warning light and a warning horn. If desired, the proximity alarm circuit may also include a display for displaying the speed of the object in the vehicle's path and/or the stopping distance in feet. The proximity alarm circuit 40 may be further equipped to provide audible indications of the speed of the object in the vehicle's path and/or the stopping distance in feet as well as selector circuitry for selecting both the information to be provided as well as the manner in which the information is to be conveyed.

Finally, the processor subsystem 12 is further provided with one or more mode select input lines which enable operator configuration of the operation of the system 10. For example, as described herein, the corrective operations consist of the combination of an automatic reduction of throttle and audio/visual alerts that the vehicle is being operated

unsafely. It is specifically contemplated, however, that the system 10 include a mode select line for switching the system 10 between an "active" mode where both automatic throttle reduction and audio/visual alerts are generated and an "inactive" mode where only audio/visual alerts are generated.

Referring next to FIGS. 2A-B, a method for optimizing vehicle performance in accordance with the teachings of the present invention will now be described in greater detail. The method commences by powering up the processor subsystem 12, for example, by closing switch 42, thereby coupling the processor subsystem 12 to the power source 44 via line 43. Alternately, the processor subsystem 12 may be connected to the electrical system of the vehicle such that it will automatically power up when the vehicle is started. Of course, any of the other devices which also form part of the system 10 and require power may also be coupled to the line 43. Appropriate voltage levels for the processor subsystem 12, as well as any additional power-demanding devices coupled to the power source 44, would be provided by voltage divider circuitry (not shown).

Once the system 10 is powered up, the method begins at step 50 by the processor subsystem 12 polling the road speed sensor 18, the RPM sensor 20, the manifold pressure sensor 22, the throttle sensor 24, the windshield wiper sensor 30 and the brake sensor 32 to determine their respective levels or states and places the acquired information in the first data register 14a. Of course, it should be noted, however, that polling of the sensors by the processor subsystem 12 is but one technique by which the processor subsystem 12 may acquire the requisite information. Alternately, each sensor 20, 22, 24, 30 and 32 may periodically place its level or state in one or more bits of the first data register 14a. The processor subsystem 12 would then acquire information by checking the contents of the first data register 14a at selected time intervals.

Proceeding to step 52, the processor subsystem 12 examines the contents of the first data register 14a to determine the operating speed of the vehicle. If the processor subsystem 12 determines that the vehicle is stationary, i.e., the operating speed of the vehicle is zero, the processor subsystem 12 will return to step 50 where the road speed sensor 18, the RPM sensor 20, the manifold pressure sensor 22, the throttle sensor 24, the windshield wiper sensor 30 and the brake sensor 32 will be repeatedly polled until an operating speed greater than zero is detected at step 52. While polling may be conducted at a variety of time intervals, a polling period of one second appears suitable for the uses contemplated herein.

Returning to step 52, once an operating speed greater than zero is detected by the processor subsystem 12, the method proceeds to step 54 where the processor subsystem 12 again polls the operating speed sensor 18, the RPM sensor 20, the manifold pressure sensor 22, the throttle sensor 24, the windshield wiper sensor 30 and the brake sensor 32, to determine their respective levels or states and places the acquired information in the first data register 14a. In turn, the contents of the first data register 14a is placed in the second data register 14b.

Proceeding now to step 56, from the polled value of the road speed sensor 18, the processor subsystem 12 determines whether the vehicle is travelling faster than 20 mph. If the operating speed of the vehicle is less than 20 mph, the method returns to step 54 where the sensors 18, 20, 22, 24, 30 and 32 will be repeatedly polled and the value of the road speed sensor examined until the processor subsystem 12 determines that the vehicle is travelling faster than 20 mph. If, however, the processor subsystem 12 determines that the vehicle is travelling faster than 20 mph, the method proceeds to step 58 where the processor subsystem 12 then determines if the vehicle is travelling faster than 50 mph, again by checking the contents of the first data register 14a.

Past this juncture, the method of the present invention will proceed through a series of steps designed to optimize vehicle operation. However, prior to optimizing vehicle operation, the processor subsystem 12 will determine if the vehicle is being operated unsafely. If so, the processor subsystem 12 will initiate corrective operations before commencing vehicle operation optimization. More specifically, if the processor subsystem 12 determines at step 58 that the vehicle is travelling at a speed greater than 50 mph, the processor subsystem 12 will initiate a process by which it will determine whether the vehicle is being operated unsafely.



The processor subsystem 12 determines that the vehicle is being operated unsafely if the speed of the vehicle is such that the stopping distance for the vehicle  $d$  is greater than the distance separating the vehicle from an object, for example, a second vehicle, in its path. In order to make this determination, the processor subsystem 12 is provided access to at least one speed/distance table. For example, stored at location 14c within the memory subsystem 14 is a first speed/stopping distance table. The speed/stopping distance table contains the relationship between vehicle speed and stopping distance. Thus, for any given speed, the processor subsystem 12 may look-up the stopping distance for that speed. Preferably, the memory subsystem 14 should contain multiple speed/stopping distance tables so that differences in road conditions and/or vehicle class may be taken into account. For example, the speed/stopping distance table stored at location 14c may be a speed/stopping distance table for dry roads while a speed/stopping distance table for wet roads may be stored at location 14d. If desired, the memory subsystem 14 may also contain additional speed/stopping distance tables for other vehicle classes. If such additional tables were provided, however, the disclosed method would need to be modified to include additional steps in which the operator provides the vehicle's class and the processor subsystem 12 selects the appropriate speed/stopping distance tables for the indicated class of vehicle.

To make the aforementioned determination of unsafe vehicle operation, the method proceeds to step 60 where the processor subsystem 12 sets the value of the expression ALARM to 1. The method then proceeds to step 62 where the processor subsystem 12 examines the state of the wiper sensor 32 and selects a speed/stopping distance table based upon the state of the wiper sensor 32. If the state of the wiper sensor 32 indicates that the windshield wiper is off, the processor subsystem 12 concludes that the vehicle is being operated in dry conditions and selects the speed/stopping distance table stored at the location 14c of the memory subsystem 14. If, however, the state of the wiper sensor 32 indicates that the windshield wiper is on, the processor subsystem 12 concludes that the vehicle is being operated in wet conditions and selects the speed/stopping distance table stored at the location 14d of the memory subsystem 14. From the selected speed/stopping distance table 14c or 14d, the processor subsystem 12 then retrieves the stopping distance for the speed at which the vehicle is travelling.

Continuing on to step 64, the processor subsystem 12 determines the distance of the vehicle to an object in its path, i.e., a second vehicle travelling in front of the vehicle and in the same direction. To do so, the processor subsystem 12 instructs the radar device 28 to determine the distance between the vehicle and the second vehicle in front of it. Upon determining the distance separating the two vehicles, the radar device 28 transmits the determined separation distance to the processor subsystem 12. At step 66, the processor subsystem 12 determines if the two vehicles are separated by a safe distance. To do so, the processor subsystem 12 compares the distance separating the two vehicles to the retrieved stopping distance for the vehicle. If the determined distance separating the two vehicles is greater than the retrieved stopping distance for the vehicle, the processor subsystem 12 determines that the vehicle is being operated safely. If, however, the determined distance separating the two vehicles is less than the retrieved stopping distance, the processor subsystem 12 determines that the vehicle is being operated unsafely.

If the processor subsystem 12 determines at step 66 that the vehicle is being operated unsafely, the processor subsystem 12 initiates appropriate corrective action. At step 68, the processor subsystem 12 determines whether the vehicle brake is on by examining the state of the brake sensor 32. If the brake is on, the processor subsystem 12 concludes that the driver is taking corrective action and that further corrective action is not necessary. If, however, the processor subsystem 12 determines that the vehicle brake is off, the method proceeds to step 70 where the processor subsystem examines the level of the vehicle speed sensor to determine if the speed of the vehicle is less than 35 mph. If the speed of the vehicle is less than 30 mph, the processor subsystem 12 concludes that no further corrective action will be taken.

If, however, the processor subsystem 12 determines that the speed of the vehicle is greater than 35 mph, the method proceeds to step 72 where the processor subsystem 12 selects a throttle reduction value based upon the value of the expression ALARM. Generally, the severity of the corrective action to be initiated by the processor subsystem 12 is varied depending on the number of times that corrective action has been taken and, more specifically, the severity of the selective corrective action increases with the value of the expression ALARM. For example, in the embodiment of the invention disclosed herein, if ALARM=1, a 25% throttle reduction is selected, if ALARM=2, a 50 throttle reduction is

selected and, if  $ALARM.gtreq.3$ , a 100% throttle reduction is selected. By reducing the throttle, the transport of fuel to the engine is retarded and the vehicle will begin to decelerate.

Continuing on to step 74, the processor subsystem 12 determines the extent to which the throttle is open using the throttle level provided by the throttle sensor 24 and, using throttle control 26, reduces the throttle by the selected percentage. At step 76, the processor subsystem 12 selects an alert mode, again based upon the value of the expression  $ALARM$ . As before, the severity of the alert mode may increase with the value of  $ALARM$ . For example, when  $ALARM=1$ , a warning light may be activated in a flash mode while, when  $2.ltreq.ALARM.ltreq.3$ , an audible alert which lasts for a first selected time period, for example, two seconds, may be activated in combination with the flashing warning light and when  $ALARM.gtreq.4$ , an audible alert which lasts for a second, longer, time period, for example, six seconds, may be activated in combination with the flashing light.

Proceeding to step 78, the processor subsystem 12 issues an alert to the operator of the vehicle in accordance with the selected alert mode. To do so, the processor subsystem 12 activates vehicle proximity alarm circuit 40 in accordance with the selected alert mode. After issuing the alert at step 78, the method proceeds to step 80 where the processor subsystem 12 waits a selected period before taking any further action. The wait period is intended to provide sufficient time to see if the previously initiated corrective action eliminates the hazardous condition. As disclosed herein, a wait period of 10 seconds is suitable. However, wait periods of various lengths should be equally suitable for the uses contemplated herein.

Upon expiration of the wait period, the value of the expression  $ALARM$  is incremented by one at step 82 and, at step 84, the processor subsystem 12 again polls the operating speed sensor 18, the RPM sensor 20, the manifold pressure sensor 22, the throttle sensor 24, the windshield wiper sensor 30 and the brake sensor 32, to determine their respective levels or states and places the acquired information in the first data register 14a. The method returns to step 64 where the distance between the vehicle and the object in its path is re-determined. The processor subsystem 12 continues to take corrective action until it determines that the vehicle is no longer being operated in a hazardous manner. More specifically, the processor subsystem 12 will conclude that the hazardous condition has been corrected when it either: determines at step 66 that the distance separating the vehicle and the object is within the stopping distance for the vehicle, determines at step 68 that the vehicle brake is on or determines at step 70 that the speed of the vehicle is less than 35 mph. Upon making such a determination, the method proceeds to step 86 where the processor subsystem 12 deactivated the vehicle proximity alarm circuit 40 to turn off the flashing light.

The method of optimizing vehicle operation in accordance with the teachings of the present invention will now be described in greater detail. Returning now to step 58, if the processor subsystem 12 determines that the vehicle is travelling slower than 50 mph, or if the processor subsystem 12 determines at step 66 that the distance separating the vehicle and the object is within the stopping distance for the vehicle or if the processor subsystem 12 determines at step 68 that the vehicle brake is on or if the processor subsystem 12 determines at step 70 that the speed of the vehicle is less than 35 mph, the method proceeds, after deactivation of the vehicle proximity alarm circuit 40, to step 88 where the processor subsystem 12 determines if the road speed of the vehicle is changing. To do so, the processor subsystem 12 compares the speed of the vehicle maintained in the first register 14a to the speed of the vehicle maintained in the second register 14b.

If the vehicle speed maintained in the first register 14a is greater than the vehicle speed maintained in the second register 14b, the vehicle is accelerating. If so, the method continues to step 90 where the processor subsystem 12 determines if the throttle position is increasing. To do so, the processor subsystem 12 compares the throttle level, i.e., the extent to which the throttled is opened, maintained in the first register 14a to the throttle level maintained in the second register 14b. If the throttle position has not increased, the processor subsystem 12 determines that, since the vehicle is accelerating but fuel consumption is not increasing, no modification of vehicle operation is necessary. Accordingly, the method returns to step 54 for a next polling of the sensors 18, 20, 22 24, 30 and 32.

If, however, the processor subsystem 12 determines at step 90 that the throttle position has increased, the method

proceeds to step 92 where the processor subsystem 12 determines if the manifold pressure level maintained in the first register 14a has exceeded the manifold pressure set point for the vehicle. If the vehicle's road speed and throttle position are increasing and the manifold pressure for the vehicle is at or below the manifold pressure set point, the processor subsystem 12 proceeds to step 93 where the sensors 18, 20, 22, 24, 30 and 32 are again polled and on to step 94 where the processor subsystem 12 compares the engine speed level maintained in the first register 14a to the RPM set point stored in the memory subsystem 14 to determine if the engine speed has reached the RPM set point. If the engine speed has not reached the RPM set point, the method returns to step 93 where the sensors 18, 20, 22, 24, 30 and 32 are repeatedly polled until the processor subsystem 12 determines that the engine speed has reached the RPM set point. Once the engine speed has reached the RPM set point, the processor subsystem 12 determines that the vehicle needs to be upshifted and, proceeding to step 95, the processor subsystem 12 will activate the upshift notification circuit 34 to issue an audible alert for a selected time period, for example, 6 seconds, thereby notifying the driver that, in order to optimize vehicle operation, an upshift should be performed. The method then returns to step 54 for a next polling of the sensors 18, 20, 22, 24, 30 and 32.

Returning to step 92, if the vehicle's road speed and throttle position are increasing and the manifold pressure for the vehicle is above the manifold pressure set point, the processor subsystem 12 determines that too much fuel is being provided to the engine and proceeding to step 96, the processor subsystem 12 will activate the overinjection notification circuit 38 to issue an audible alert for a selected time period, for example, 6 seconds, thereby notifying the driver that, in order to optimize vehicle operation, the amount of fuel being supplied to the engine should be reduced. The method then returns to step 54 for a next polling of the sensors 18, 20, 22, 24, 30 and 32.

Returning to step 88, if the processor subsystem 12 determines, when comparing the speed of the vehicle maintained in the first register 14a to the speed of the vehicle maintained in the second register 14b, that the speed of the vehicle is decreasing, the method proceeds to step 98 where the processor subsystem 12 determines if the throttle position is changing. To do so, the processor subsystem 12 compares the throttle level, i.e., the extent to which the throttled is opened, maintained in the first register 14a to the throttle level maintained in the second register 14b. If the throttle position has either remained constant or decreased, the processor subsystem 12 determines that, since fuel consumption is either constant or reduced, no modification of vehicle operation is necessary. Accordingly, the method returns to step 54 for a next polling of the sensors 18, 20, 22, 24, 30 and 32.

If, however, the processor subsystem 12 determines at step 98 that the throttle position has increased, the method proceeds to step 100 where the processor subsystem 12 determines if the manifold pressure is increasing. To do so, the processor subsystem 12 compares the manifold pressure level maintained in the first register 14a to the manifold pressure level maintained in the second register 14b. If the manifold pressure level maintained in the first register 14a is less than the manifold pressure level maintained in the second register 14b, the processor subsystem 12 determines that, since manifold pressure is decreasing, no modification of vehicle operation is necessary. Accordingly, the method returns to step 54 for a next polling of the sensors 18, 20, 22, 24, 30 and 32.

If, however, the manifold pressure level maintained in the first register 14a is greater than the manifold pressure level maintained in the second register 14b, the processor subsystem 12 determines that the manifold pressure for the vehicle is increasing and the method proceeds to step 102 where the processor subsystem 12 determines if the engine speed is increasing. To do so, the processor subsystem 12 compares the engine speed level maintained in the first register 14a to the engine speed level maintained in the second register 14b. If the engine speed level maintained in the first register 14a is less than the engine speed level maintained in the second register 14b, the processor subsystem 12 determines that, since engine speed is increasing, no modification of vehicle operation is necessary. Accordingly, the method returns to step 54 for a next polling of the sensors 18, 20, 22, 24, 30 and 32.

If, however, the engine speed level maintained in the first register 14a is less than the engine speed level maintained in the second register 14b, the processor subsystem 12 determines that, since the manifold pressure is increasing while the engine speed is decreasing, too much fuel is being supplied to the engine. Accordingly, at step 104, the processor subsystem 12 activates the overinjection notification circuit 38 to issue an audible alert for a selected time period, for

example, 6 seconds, thereby notifying the driver that, in order to optimize vehicle operation, the amount of fuel being supplied to the engine should be reduced.

Proceeding on to step 106, the sensors 18, 20, 22 24, 30 and 32 are again polled and, at step 108, the processor subsystem 12 determines if the engine speed is decreasing, again by comparing the engine speed level maintained in the first and second registers 14a and 14b. If the engine speed has not decreased, the method returns to step 104 where the processor subsystem 12 again activates the overinjection notification circuit 38 to issue another audible alert notifying the driver that, in order to optimize vehicle operation, the amount of fuel being supplied to the engine should be reduced. Thus, the driver will be repeatedly notified of the overinjection condition until the processor subsystem 12 determines, at step 108, that the engine speed is decreasing. The method will then proceed to step 110 where, since the processor subsystem 12 has determined that, since the engine speed is decreasing, the vehicle should be downshifted. Accordingly, at step 110, the processor subsystem 12 activates the downshift notification circuit 36 to issue an audible alert for a selected time period, for example, 6 seconds, thereby notifying the driver that, in order to optimize vehicle operation, the vehicle should be downshifted. The method then returns to step 54 for a next polling of the sensors 18, 20, 22 24, 30 and 32. The method will repeatedly loop through the aforementioned process to continuously determine if the vehicle is being operated unsafely, take appropriate corrective action and to provide notifications to the driver as to how operation of the vehicle may be optimized until the processor subsystem 12 is powered down or the vehicle is turned off.

Thus, there has been described and illustrated herein, an apparatus for optimizing vehicle operation which combines both operator notifications of recommended corrections in vehicle operation with automatic modification of vehicle operation under certain circumstances. By incorporating the disclosed apparatus in a vehicle, not only will certain hazardous operations of the vehicle be prevented but also the driver will be advised of certain actions which will enable the vehicle to be operated with greater fuel efficiency. However, those skilled in the art will recognize that many modifications and variations besides those specifically mentioned herein may be made without departing substantially from the concept of the present invention. Accordingly, it should be clearly understood that the form of the invention described herein is exemplary only and is not intended as a limitation on the scope of the invention.

#### **ENGLISH-CLAIMS:**

Return to Top of Patent

1. Apparatus for optimizing operation of a vehicle, comprising: a plurality of sensors coupled to a vehicle having an engine, said plurality of sensors, which collectively monitor operation of said vehicle, including a road speed sensor, an engine speed sensor, a manifold pressure sensor and a throttle position sensor; a processor subsystem, coupled to each one of said plurality of sensors, to receive data therefrom; a memory subsystem, coupled to said processor subsystem, said memory subsystem storing therein a manifold pressure set point, an RPM set point, and present and prior levels for each one of said plurality of sensors; a fuel overinjection notification circuit coupled to said processor subsystem, said fuel overinjection notification circuit issuing a notification that excessive fuel is being supplied to said engine of said vehicle; an upshift notification circuit coupled to said processor subsystem, said upshift notification circuit issuing a notification that said engine of said vehicle is being operated at an excessive speed; said processor subsystem determining, based upon data received from said plurality of sensors, when to activate said fuel overinjection circuit and when to activate said upshift notification circuit.

2. Apparatus for optimizing operation of a vehicle according to claim 1 wherein said processor subsystem further comprises: means for determining when road speed for said vehicle is increasing; means for determining when throttle position for said vehicle is increasing; and means for comparing manifold pressure to said manifold pressure set point; said processor subsystem activating said fuel overinjection notification circuit if both road speed and throttle position for said vehicle are increasing and manifold pressure for said vehicle is above said manifold pressure set point.

3. Apparatus for optimizing operation of a vehicle according to claim 1 wherein said fuel overinjection circuit

further comprises a horn for issuing a tone for a preselected time period.

4. Apparatus for optimizing operation of a vehicle according to claim 1 wherein said processor subsystem further comprises: means for determining when road speed for said vehicle is decreasing; means for determining when throttle position for said vehicle is increasing; means for determining when manifold pressure for said vehicle is increasing; and means for determining when engine speed for said vehicle is decreasing; said processor subsystem activating said fuel overinjection notification circuit if both throttle position and manifold pressure for said vehicle are increasing and road speed and engine speed for said vehicle are decreasing.

5. Apparatus for optimizing operation of a vehicle according to claim 1 wherein said processor subsystem further comprises: means for determining when road speed for said vehicle is increasing; means for determining when throttle position for said vehicle is increasing; means for comparing manifold pressure to said manifold pressure set point; and means for comparing engine speed to said RPM set point; said processor subsystem activating said upshift notification circuit if both road speed and throttle position for said vehicle are increasing, manifold pressure for said vehicle is at or below said manifold pressure set point and engine speed for said vehicle is at or above said RPM set point.

6. Apparatus for optimizing operation of a vehicle according to claim 1 wherein said upshift notification circuit further comprises a horn for issuing a tone for a preselected time period.

7. Apparatus for optimizing operation of a vehicle, comprising: a plurality of sensors coupled to a vehicle having an engine, said plurality of sensors, which collectively monitor operation of said vehicle, including a road speed sensor, a manifold pressure sensor and a throttle position sensor; a processor subsystem, coupled to each one of said plurality of sensors, to receive data therefrom; a memory subsystem, coupled to said processor subsystem, said memory subsystem storing therein a manifold pressure set point and present and prior levels for each one of said plurality of sensors; a fuel overinjection notification circuit coupled to said processor subsystem, said fuel overinjection notification circuit issuing a notification that excessive fuel is being supplied to said engine of said vehicle; a downshift notification circuit coupled to said processor subsystem, said downshift notification circuit issuing a notification that said engine of said vehicle is being operated at an insufficient engine speed; and said processor subsystem determining, based upon data received from said plurality of sensors, when to activate said fuel overinjection circuit and when to activate said downshift notification circuit.

8. Apparatus for optimizing operation of a vehicle according to claim 7 wherein said processor subsystem further comprises: means for determining when road speed for said vehicle is increasing; means for determining when throttle position for said vehicle is increasing; and means for comparing manifold pressure to said manifold pressure set point; said processor subsystem activating said fuel overinjection notification circuit if both road speed and throttle position for said vehicle are increasing and manifold pressure for said vehicle is above said manifold pressure set point.

9. Apparatus for optimizing operation of a vehicle according to claim 7 wherein said fuel overinjection circuit further comprises a horn for issuing a tone for a preselected time period.

10. Apparatus for optimizing operation of a vehicle according to claim 7 wherein said processor subsystem further comprises: means for determining when road speed for said vehicle is decreasing; means for determining when throttle position for said vehicle is increasing; means for determining when manifold pressure for said vehicle is increasing; and means for determining when engine speed for said vehicle is decreasing; said processor subsystem activating said downshift notification circuit if both road speed and engine speed are decreasing and both throttle position and manifold pressure for said vehicle are increasing.

11. Apparatus for optimizing operation of a vehicle according to claim 10 wherein said downshift notification circuit further comprises a horn for issuing a tone for a preselected time period.

12. Apparatus for optimizing operation of a vehicle according to claim 7 wherein said processor subsystem further comprises: means for determining when road speed for said vehicle is decreasing; means for determining when throttle

position for said vehicle is increasing; means for determining when manifold pressure for said vehicle is increasing; and means for determining when engine speed for said vehicle is decreasing; said processor subsystem activating said fuel overinjection notification circuit if both throttle position and manifold pressure for said vehicle are increasing and road speed and engine speed for said vehicle are decreasing.

13. Apparatus for optimizing operation of a vehicle, comprising: a plurality of sensors coupled to a vehicle having an engine, said plurality of sensors, which collectively monitor operation of said vehicle, including a road speed sensor, an engine speed sensor, a manifold pressure sensor and a throttle position sensor; a processor subsystem, coupled to each one of said plurality of sensors, to receive data therefrom; a memory subsystem, coupled to said processor subsystem, said memory subsystem storing therein a manifold pressure set point, an engine speed set point and present and prior levels for each one of said plurality of sensors; a fuel overinjection notification circuit coupled to said processor subsystem, said fuel overinjection notification circuit issuing a notification that excessive fuel is being supplied to said engine of said vehicle; an upshift notification circuit coupled to said processor subsystem, said upshift notification circuit issuing a notification that said engine of said vehicle is being operated at an excessive engine speed; a downshift notification circuit coupled to said processor subsystem, said downshift notification circuit issuing a notification that said engine of said vehicle is being operated at an insufficient engine speed; said processor subsystem determining, based upon data received from said plurality of sensors, when to activate said fuel overinjection circuit, said upshift notification circuit and said downshift notification circuit.

14. Apparatus for optimizing operation of a vehicle according to claim 13 wherein: said fuel overinjection circuit further comprises a first horn for issuing a first tone for a first preselected time period; said upshift notification circuit further comprises a second horn for issuing a second tone for a second preselected time period; and said downshift notification circuit further comprises a third horn for issuing a third tone for a third preselected time period.

15. Apparatus for optimizing vehicle performance according to claim 13 wherein said processor subsystem further comprises: means for determining when road speed for said vehicle is increasing or decreasing means for determining when throttle position for said vehicle is increasing; means for comparing manifold pressure to said manifold pressure set point; means for comparing engine speed to said RPM set point; means for determining when manifold pressure is increasing; and means for determining when engine speed is increasing or decreasing; said processor subsystem activating said fuel overinjection notification circuit if both road speed and throttle position for said vehicle are increasing and manifold pressure for said vehicle is above said manifold pressure set or if both throttle position and manifold pressure for said vehicle are increasing and road speed and engine speed for said vehicle are decreasing; said processor subsystem activating said upshift notification circuit if both road speed and throttle position for said vehicle are increasing, manifold pressure for said vehicle is at or below said manifold pressure set point and engine speed for said vehicle is at or above said RPM set point; and said processor subsystem activating said downshift notification circuit if both road speed and engine speed are decreasing and both throttle position and manifold pressure for said vehicle are increasing.

16. Apparatus for optimizing operation of a vehicle according to claim 15 wherein: said fuel overinjection circuit further comprises a first horn for issuing a first tone for a first preselected time period; said upshift notification circuit further comprises a second horn for issuing a second tone for a second preselected time period; and said downshift notification circuit further comprises a third horn for issuing a third tone for a third preselected time period.

17. Apparatus for optimizing operation of a vehicle, comprising: a radar detector, said radar detector determining a distance separating a vehicle having an engine and an object in front of said vehicle; at least one sensor coupled to said vehicle for monitoring operation thereof, said at least one sensor including a road speed sensor, a manifold pressure sensor, a throttle position sensor and an engine speed sensor; a processor subsystem, coupled to said radar detector and said at least one sensor, to receive data therefrom; a memory subsystem, coupled to said processor subsystem, said memory subsystem storing a first vehicle speed/stopping distance table, a manifold pressure set point, an RPM set point, a present level for each one of said at least one sensor and a prior level for each one of said at least one sensor; a vehicle proximity alarm circuit coupled to said processor subsystem, said vehicle proximity alarm circuit issuing an alarm that

said vehicle is too close to said object; a fuel overinjection circuit coupled to said processor subsystem, said fuel overinjection circuit issuing a notification that excessive fuel is being supplied to said engine of said vehicle; an upshift notification circuit coupled to said processor subsystem, said upshift notification circuit issuing a notification that said engine of said vehicle is being operated at an excessive speed; said processor subsystem determining, based upon data received from said radar detector, said at least one sensor and said memory subsystem, when to activate said vehicle proximity alarm circuit, when to activate said fuel overinjection circuit, and when to activate said upshift notification circuit.

18. Apparatus for optimizing operation of a vehicle according to claim 17 wherein: said at least one sensor further includes a windshield wiper sensor for indicating whether a windshield wiper of said vehicle is activated; and said memory subsystem further storing a second vehicle speed/stopping distance table.

19. Apparatus for optimizing operation of a vehicle according to claim 17 and further comprising: a throttle controller for controlling a throttle of said engine of said vehicle; and said processor subsystem selectively reducing said throttle based upon data received from said radar detector, said at least one sensor and said memory subsystem.

20. Apparatus for optimizing operation of a vehicle according to claim 19 wherein said at least one sensor further includes a brake sensor for indicating whether a brake system of said vehicle is activated.

21. Apparatus for optimizing operation of a vehicle according to claim 19 wherein said processor subsystem further comprises: means for counting a total number of vehicle proximity alarms determined by said processor subsystem; means for selectively reducing said throttle based upon said total number of vehicle proximity alarms.

22. Apparatus for optimizing operation of a vehicle according to claim 17 and further comprising: a downshift notification circuit coupled to said processor subsystem, said downshift notification circuit issuing a notification that said engine of said vehicle is being operated at an insufficient engine speed; and said processor subsystem determining, based upon data received from said plurality of sensors, when to activate said downshift notification circuit.

23. Apparatus for optimizing operation of a vehicle, comprising: a radar detector, said radar detector determining a distance separating a vehicle having an engine and an object in front of said vehicle; a plurality of sensors coupled to a vehicle having an engine, said plurality of sensors, which collectively monitor operation of said vehicle, including a road speed sensor, and engine speed sensor, a manifold pressure sensor and a throttle position sensor; a processor subsystem, coupled to said radar detector and each one of said plurality of sensors, to receive data therefrom; a memory subsystem, coupled to said processor subsystem, said memory subsystem storing therein a first vehicle speed/stopping distance table, a manifold pressure set point, an RPM set point, and present and prior levels for each one of said plurality of sensors; a fuel overinjection notification circuit coupled to said processor subsystem, said fuel overinjection notification circuit issuing a notification that excessive fuel is being supplied to said engine of said vehicle; an upshift notification circuit coupled to said processor subsystem, said upshift notification circuit issuing a notification that said engine of said vehicle is being operated at an excessive engine speed; said processor subsystem determining, based upon data received from said plurality of sensors, when to activate said fuel overinjection circuit and when to activate said upshift notification circuit; a vehicle proximity alarm circuit coupled to said processor subsystem, said vehicle proximity alarm circuit issuing an alarm that said vehicle is too close to said object; said processor subsystem determining, based upon data received from said radar detector, said at least one sensor and said memory subsystem, when to activate said vehicle proximity alarm circuit.

24. Apparatus for optimizing operation of a vehicle according to claim 23 wherein said processor subsystem further comprises: means for determining when road speed for said vehicle is increasing or decreasing; means for determining when throttle position for said vehicle is increasing or decreasing; and means for comparing manifold pressure to said manifold pressure set point; means for determining when manifold pressure for said vehicle is increasing or decreasing; and means for determining when engine speed for said vehicle is increasing or decreasing; said processor subsystem activating said fuel overinjection notification circuit if both road speed and throttle position for said vehicle are

increasing and manifold pressure for said vehicle is above said manifold pressure set point or if both throttle position and manifold pressure for said vehicle are increasing and road speed and engine speed for said vehicle are decreasing.

25. Apparatus for optimizing operation of a vehicle according to claim 23 wherein said processor subsystem further comprises: means for determining when road speed for said vehicle is increasing; means for determining when throttle position for said vehicle is increasing; means for comparing manifold pressure to said manifold pressure set point; and means for comparing engine speed to said RPM set point; said processor subsystem activating said upshift notification circuit if both road speed and throttle position for said vehicle are increasing, manifold pressure for said vehicle is at or below said manifold pressure set point and engine speed for said vehicle is at or above said RPM set point.

26. Apparatus for optimizing operation of a vehicle, comprising: a radar detector, said radar detector determining a distance separating a vehicle having an engine and an object in front of said vehicle; a plurality of sensors coupled to a vehicle having an engine, said plurality of sensors, which collectively monitor operation of said vehicle, including a road speed sensor, and engine speed sensor, a manifold pressure sensor and a throttle position sensor; a processor subsystem, coupled to said radar detector and each one of said plurality of sensors, to receive data therefrom; a memory subsystem, coupled to said processor subsystem, said memory subsystem storing therein a first vehicle speed/stopping distance table, a manifold pressure set point, RPM set point, and present and prior levels for each one of said plurality of sensors; a fuel overinjection notification circuit coupled to said processor subsystem, said fuel overinjection notification circuit issuing a notification that excessive fuel is being supplied to said engine of said vehicle; a downshift notification circuit coupled to said processor subsystem, said downshift notification circuit issuing a notification that said engine of said vehicle is being operated at an insufficient engine speed; said processor subsystem determining, based upon data received from said plurality of sensors, when to activate said fuel overinjection circuit and when to activate said downshift notification circuit; a vehicle proximity alarm circuit coupled to said processor subsystem, said vehicle proximity alarm circuit issuing an alarm that said vehicle is too close to said object; said processor subsystem determining, based upon data received from said radar detector, said at least one sensor and said memory subsystem, when to activate said vehicle proximity alarm circuit.

27. Apparatus for optimizing operation of a vehicle according to claim 26 wherein said processor subsystem further comprises: means for determining when road speed for said vehicle is decreasing; means for determining when throttle position for said vehicle is increasing; means for determining when manifold pressure for said vehicle is increasing; and means for determining when engine speed for said vehicle is decreasing; said processor subsystem activating said downshift notification circuit if both road speed and engine speed are decreasing and both throttle position and manifold pressure for said vehicle are increasing.

28. Apparatus for optimizing operation of a vehicle, comprising: a plurality of sensors coupled to a vehicle having an engine, said plurality of sensors, which collectively monitor operation of said vehicle, including a road speed sensor, a manifold pressure sensor and a throttle position sensor; a processor subsystem, coupled to each one of said plurality of sensors, to receive data therefrom; a fuel overinjection notification circuit coupled to said processor subsystem, said fuel overinjection notification circuit issuing a notification that excessive fuel is being supplied to said engine of said vehicle; said processor subsystem determining whether to activate said fuel overinjection notification sensor based upon data received from said road speed sensor, said throttle position sensor and said manifold pressure sensor.

29. Apparatus according to claim 28 and further comprising: a memory subsystem, coupled to said processor subsystem, said memory subsystem maintaining a manifold pressure set point; said processor subsystem activating said fuel overinjection notification circuit upon determining that: (1) based upon data received from said road speed sensor, road speed of said vehicle is increasing; (2) based upon data received from said throttle position sensor, throttle position for said vehicle is increasing; and (3) based upon data received from said manifold pressure sensor, manifold pressure for said vehicle exceeds said manifold pressure set point.

30. Apparatus according to claim 28, wherein: said plurality of sensors coupled to said vehicle further include an engine speed sensor; said processor subsystem activating said fuel overinjection notification circuit upon determining



that: (1) based upon data received from said road speed sensor, road speed of said vehicle is decreasing; (2) based upon data received from said throttle position sensor, throttle position for said vehicle is increasing; (3) based upon data received from said manifold pressure sensor, manifold pressure for said vehicle is increasing; and (4) based upon data received from said engine speed sensor, engine speed for said vehicle is decreasing.

31. Apparatus for optimizing operation of a vehicle, comprising: a radar detector, said radar detector determining a distance separating a vehicle having an engine and an object in front of said vehicle; at least one sensor coupled to said vehicle for monitoring operation thereof, said at least one sensor including a road speed sensor; a processor subsystem, coupled to said radar detector and said at least one sensor, to receive data therefrom; a memory subsystem, coupled to said processor subsystem, said memory subsystem storing a first vehicle speed/stopping distance table; a vehicle proximity alarm circuit coupled to said processor subsystem, said vehicle proximity alarm circuit issuing an alarm that said vehicle is too close to said object; said processor subsystem determining whether to activate said vehicle proximity alarm circuit based upon separation distance data received from said radar detector, vehicle speed data received from said road speed sensor and said first vehicle speed/stopping distance table stored in said memory subsystem.

32. Apparatus for optimizing operation of a vehicle according to claim 31 wherein: said at least one sensor further includes a windshield wiper sensor for indicating whether a windshield wiper of said vehicle is activated; and said memory subsystem further storing a second vehicle speed/stopping distance table; if said windshield wiper sensor indicates that said windshield wiper is deactivated, said processor subsystem determining whether to activate said vehicle proximity alarm circuit based upon data received from said radar detector, said road speed sensor and said first vehicle speed/stopping distance table stored in said memory subsystem; if said windshield wiper sensor indicates that said windshield wiper is activated, said processor subsystem determining whether to activate said vehicle proximity alarm circuit based upon data received from said radar detector, said road speed sensor and said second vehicle speed/stopping distance table stored in said memory subsystem.

**LOAD-DATE:** March 12, 2015



Switch Client | Preferences | Help | Sign Out

My Lexis™ Search  Get a Document Shepard's® More History Alerts

All Legal News & Business Public Records Patent Law Trademark Law Criminal Law

Find a Source > Patent Cases from Federal Courts and Administrative Materials

Search View Tutorial | Help

Select Search Type and Enter Search Terms

Terms & Connectors: 5954781 or 5,954,781

Natural Language

Easy Search

Suggest terms for my search

Check spelling

**Restrict by Document Segment**

Select a document segment, enter search terms for the segment, then click Add.

Select a Segment

Note: Segment availability differs between sources. Segments may not be applied consistently across sources.

**Restrict by Date**

No Date Restrictions  From  To  Date formats...

---

**Search Connectors**

and	and	w/p	in same paragraph
or	or	w/seg	in same segment
w/N	within N words	w/s	in same sentence
pre/N	precedes by N words	and not	and not

More Connectors & Commands...

**How Do I...?**

- Combine sources?
- Restrict by date?
- Restrict by document segment?
- Use wildcards as placeholders for one or more characters in a search term?
- View Tutorials

1. Velocity Patent, LLC v. Audi of Am., Inc., Case No. 13-cv-8418, UNITED STATES DISTRICT COURT FOR THE NORTHERN DISTRICT OF ILLINOIS, EASTERN DIVISION, 2015 U.S. Dist. LEXIS 6369, January 21, 2015, Decided, January 21, 2015, Filed

... Complaint alleging infringement of U.S. Patent No. 5,954,781 by Defendant Audi of America, Inc. ("Defendant" ...

2. Velocity Patent LLC v. Mercedes-Benz USA, LLC, Case No. 13-cv-8413, UNITED STATES DISTRICT COURT FOR THE NORTHERN DISTRICT OF ILLINOIS, EASTERN DIVISION, 2014 U.S. Dist. LEXIS 57602, April 24, 2014, Decided, April 24, 2014, Filed, Related proceeding at Velocity Patent LLC v. Audi of Am., Inc., 2014 U.S. Dist. LEXIS 115699 (N.D. Ill., Aug. 19, 2014)

... AND ORDER Velocity owns U.S. Patent No. 5,954,781 ("the '781 patent"). On November 21, 2014, ...



Switch Client | Preferences | Help | Sign Out

My Lexis™ Search  Get a Document Shepard's® More History Alerts

All Legal News & Business Public Records Patent Law Trademark Law Criminal Law

Find a Source > Patent, Trademark & Copyright Periodicals, Combined

Search View Tutorial | Help

Select Search Type and Enter Search Terms

Terms & Connectors: 5954781 or 5,954,781

Natural Language  
Easy Search

Suggest terms for my search

Check spelling

**Restrict by Document Segment**

Select a document segment, enter search terms for the segment, then click Add.

Select a Segment

**Note:** Segment availability differs between sources. Segments may not be applied consistently across sources.

**Restrict by Date**

No Date Restrictions  From  To  Date formats...

---

**Search Connectors**

and	and	w/p	in same paragraph
or	or	w/seg	in same segment
w/N	within N words	w/s	in same sentence
pre/N	precedes by N words	and not	and not

More Connectors & Commands...

**How Do I...?**

- Combine sources?
- Restrict by date?
- Restrict by document segment?
- Use wildcards as placeholders for one or more characters in a search term?
- View Tutorials

**No Documents Found**

No documents were found for your search terms  
"5954781 or 5,954,781"

Click "Save this search as an Alert" to schedule your search to run in the future.

- OR -

Click "Search Using Natural Language" to run your search as Natural Language search.

- OR -

Click "Edit Search" to return to the search form and modify your search.

Suggestions:

- Check for spelling errors.
- Remove some search terms.
- Use more common search terms, such as those listed in "Suggested Words and Concepts."
- Use a less restrictive date range.
- Use "OR" in between terms to search for one term or the other.

**| Save this Search as an Alert || Search Using Natural Language || Edit Search |**



Switch Client | Preferences | Help | Sign Out

My Lexis™ Search  Get a Document Shepard's® More History Alerts

All Legal News & Business Public Records Patent Law Trademark Law Criminal Law

Find a Source > All English Language News

Search View Tutorial | Help

Select Search Type and Enter Search Terms

Terms & Connectors: 5954781 or 5,954,781

Natural Language

Easy Search

Suggest terms for my search

Search

Check spelling

**Restrict by Document Segment**

Select a document segment, enter search terms for the segment, then click Add.

Select a Segment  Add

Note: Segment availability differs between sources. Segments may not be applied consistently across sources.

**Restrict by Date**

No Date Restrictions  From  To  Date formats...

---

**Search Connectors**

and	and	w/p	in same paragraph
or	or	w/seg	in same segment
w/N	within N words	w/s	in same sentence
pre/N	precedes by N words	and not	and not

More Connectors & Commands...

**How Do I...?**

- Combine sources?
- Restrict by date?
- Restrict by document segment?
- Use wildcards as placeholders for one or more characters in a search term?
- View Tutorials

**No Documents Found**

No documents were found for your search terms  
"5954781 or 5,954,781"

Click "Save this search as an Alert" to schedule your search to run in the future.

- OR -

Click "Search Using Natural Language" to run your search as Natural Language search.

- OR -

Click "Edit Search" to return to the search form and modify your search.

Suggestions:

- Check for spelling errors.
- Remove some search terms.
- Use more common search terms, such as those listed in "Suggested Words and Concepts."
- Use a less restrictive date range.
- Use "OR" in between terms to search for one term or the other.

**| Save this Search as an Alert || Search Using Natural Language || Edit Search |**

---

## United States Patent Trial and Appeals Board

US Patent Trial and Appeals Board - Alexandria  
(Alexandria)

**IPR2015-00276**

**Volkswagen Group of America, Inc. Vs. Velocity Patent LLC**

**This case was retrieved from the court on Monday, March 23, 2015**

---

### Header

Case Number: IPR2015-00276  
Date Filed: 11/21/2014  
Date Full Case Retrieved: 03/23/2015  
Status: Open  
Misc: Civil

[Summary][Participants][Proceedings]

### Summary

Court Case Status: Pending  
Case Type: IPR: Inter partes review  
Technical Center Number: 3600  
Patent Application Number: 08813270  
Patent Number: 5954781

### Participants

#### **Litigants**

Volkswagen Group of America, Inc.  
Petitioner

Velocity Patent LLC  
PatentOwner

### Proceedings

<b><u>File Date</u></b>	<b><u>Details</u></b>	<b><u>Document Type</u></b>	<b><u>Paper/Exhibit No.</u></b>	<b><u>Filed By</u></b>	<b><u>Public?</u></b>
11/21/2014	Power of Attorney	Power of Attorney	1	Petitioner	Yes
11/21/2014	Petition	Petition	2	Petitioner	Yes
11/21/2014	Us5954781	Exhibit	1001	Petitioner	Yes
11/21/2014	Automotive Electronic Handbook	Exhibit	1002	Petitioner	Yes
11/21/2014	Us4398174	Exhibit	1003	Petitioner	Yes



11/21/2014	Us4559599	Exhibit	1004	Petitioner	Yes
11/21/2014	Us5357438	Exhibit	1005	Petitioner	Yes
11/21/2014	Wo9602853	Exhibit	1006	Petitioner	Yes
11/21/2014	August 6, 1998 Office Action in US Patent Application 08/813,270	Exhibit	1007	Petitioner	Yes
11/21/2014	Part I - Request for Ex Parte Reexam 90/013,252	Exhibit	1008	Petitioner	Yes
11/21/2014	Part II - Request for Ex Parte Reexam 90/013,252	Exhibit	1008	Petitioner	Yes
11/21/2014	Part IV - Request for Ex Parte Reexam 90/013,252	Exhibit	1008	Petitioner	Yes
11/21/2014	Part V - Request for Ex Parte Reexam 90/013,252	Exhibit	1008	Petitioner	Yes
11/21/2014	Part III - Request for Ex Parte Reexam 90/013,252	Exhibit	1008	Petitioner	Yes
11/21/2014	Decision Granting in Ex Parte Reexamination 90/013,252	Exhibit	1009	Petitioner	Yes
11/21/2014	Petition for IPR2014-01247	Exhibit	1010	Petitioner	Yes
11/21/2014	October 21, 2014 Office Action in Ex Parte Reexamination 90/013,252	Exhibit	1011	Petitioner	Yes
11/21/2014	Response in Ex Parte Reexamination 90/013,252	Exhibit	1012	Petitioner	Yes
12/03/2014	Notice of Filing Date Accorded to Petition	Notice of Filing Date Accorded to Petition	3	Board	Yes
12/12/2014	Power of Attorney	Power of Attorney	4	Potential Patent Owner	Yes
12/12/2014	Related Matters	Notice	5	Potential Patent Owner	Yes
03/02/2015	Preliminary Response	Preliminary Response	6	Patent Owner	Yes
03/02/2015	Waiver of patent Onwer Statement in Ex Parte Reexamination	Exhibit	2001	Patent Owner	Yes
03/02/2015	Audi's Motion to Stay District Court litigation	Exhibit	2002	Patent Owner	Yes
03/02/2015	Blackline comparison of paragraphs in Volkswagen's IPR2015-00276 Petition	Exhibit	2003	Patent Owner	Yes
03/02/2015	USPTO patent database search results	Exhibit	2004	Patent Owner	Yes
03/02/2015	Two blackline comparisons of paragraphs in Volkswagen's request for ex parte reexamination and volkswagen's IPR2015-00276	Exhibit	2005	Patent Owner	Yes
03/02/2015	U.S. Patent Publication 2013/0124550	Exhibit	2006	Patent Owner	Yes
03/02/2015	U.S. Patent Publication 2014/0240114	Exhibit	2007	Patent Owner	Yes

03/02/2015	U.S. Patent 6,842m677	Exhibit	2008	Patent Owner	Yes
03/02/2015	Article Eco Driving Uncovered	Exhibit	2009	Patent Owner	Yes

---

Copyright © 2015 LexisNexis CourtLink, Inc. All rights reserved.  
\*\*\* THIS DATA IS FOR INFORMATIONAL PURPOSES ONLY \*\*\*

---

## United States Patent Trial and Appeals Board

US Patent Trial and Appeals Board - Alexandria  
(Alexandria)

**IPR2015-00290**

**Mercedes-Benz USA, LLC Vs. Velocity Patent, LLC**

**This case was retrieved from the court on Monday, March 23, 2015**

---

### Header

Case Number: IPR2015-00290  
Date Filed: 11/21/2014  
Date Full Case Retrieved: 03/23/2015  
Status: Open  
Misc: Civil

[Summary][Participants][Proceedings]

### Summary

Court Case Status: Pending  
Case Type: IPR: Inter partes review  
Technical Center Number: 3600  
Patent Application Number: 08813270  
Patent Number: 5954781

### Participants

#### **Litigants**

Mercedes-Benz USA, LLC  
Petitioner

Velocity Patent, LLC  
PatentOwner

### Proceedings

<b><u>File Date</u></b>	<b><u>Details</u></b>	<b><u>Document Type</u></b>	<b><u>Paper/Exhibit No.</u></b>	<b><u>Filed By</u></b>	<b><u>Public?</u></b>
11/21/2014	Power of Attorney	Power of Attorney	1	Petitioner	Yes
11/21/2014	Mercedes' IPR Petition	Petition	2	Petitioner	Yes
11/21/2014	Asserted Patent	Exhibit	1001	Petitioner	Yes
11/21/2014	Asserted Patent File History	Exhibit	1002	Petitioner	Yes
11/21/2014	Chasteen (Cited Reference)	Exhibit	1003	Petitioner	Yes
11/21/2014	Doi (Cited Reference)	Exhibit	1004	Petitioner	Yes

11/21/2014	Tresse (Base Reference)	Exhibit	1005	Petitioner	Yes
11/21/2014	Davidian (Base Reference)	Exhibit	1006	Petitioner	Yes
11/21/2014	Montague (Base Reference)	Exhibit	1007	Petitioner	Yes
11/21/2014	Kajiwata (Secondary Reference)	Exhibit	1008	Petitioner	Yes
11/21/2014	Tonkin (Secondary Reference)	Exhibit	1009	Petitioner	Yes
11/21/2014	Declaration of Dr. Chris G. Bartone, P.E.	Exhibit	1010	Petitioner	Yes
11/21/2014	CV of Dr. Chris G. Bartone, P.E.	Exhibit	1011	Petitioner	Yes
11/21/2014	Excerpts From Reexamination File History	Exhibit	1012	Petitioner	Yes
11/21/2014	Amended Claims From Reexamination	Exhibit	1013	Petitioner	Yes
11/21/2014	Rashid (Secondary Reference)	Exhibit	1014	Petitioner	Yes
11/21/2014	Hibino (Secondary Reference)	Exhibit	1015	Petitioner	Yes
11/21/2014	Weidman (Background)	Exhibit	1016	Petitioner	Yes
11/21/2014	Nishikawa (Background)	Exhibit	1017	Petitioner	Yes
12/09/2014	Notice of Filing Date Accorded to Petition	Notice of Filing Date Accorded to Petition	3	Board	Yes
12/18/2014	Power of Attorney	Power of Attorney	4	Potential Patent Owner	Yes
12/18/2014	Related Matters	Notice	5	Potential Patent Owner	Yes
12/18/2014	Related Matters	Notice	6	Potential Patent Owner	Yes
12/23/2014	Certificate of Service of the Mandatory Notice	Notice	7	Patent Owner	Yes
01/13/2015	Notice of Submission of 1/12/2015 Board Conference Transcript	Notice	8	Petitioner	Yes
01/13/2015	Exhibit 1018 (Transcript of 1/12/2015 Board Conference)	Exhibit	1018	Petitioner	Yes
01/21/2015	Order Denying Request for Authorization to File Motion to Stay	Order	9	Board	Yes
01/21/2015	Expunged	Order	10	Board	Yes
02/04/2015	ORDER Dismissing Petition	Notice	11	Board	Yes
02/11/2015	Petitioner Request for Refund	Refund Request	12	Petitioner	Yes
02/12/2015	Notice of Refund	Refund Approval	13	Board	Yes

\*\*\* THIS DATA IS FOR INFORMATIONAL PURPOSES ONLY \*\*\*

---

## United States Patent Trial and Appeals Board

US Patent Trial and Appeals Board - Alexandria  
(Alexandria)

**IPR2014-01247**

**Mercedes-Benz USA, LLC Vs. Velocity Patent, LLC**

**This case was retrieved from the court on Monday, March 23, 2015**

---

### Header

Case Number: IPR2014-01247  
Date Filed: 08/04/2014  
Date Full Case Retrieved: 03/23/2015  
Status: Closed  
Misc: Civil

[Summary][Participants][Proceedings]

### Summary

Court Case Status: Settled  
Case Type: IPR: Inter partes review  
Date of Decision to Institute Case: 1/6/2015  
Technical Center Number: 3600  
Patent Application Number: 08813270  
Patent Number: 5954781

### Participants

#### Litigants

Mercedes-Benz USA, LLC  
Petitioner

Velocity Patent, LLC  
PatentOwner

### Proceedings

<u>File Date</u>	<u>Details</u>	<u>Document Type</u>	<u>Paper/Exhibit No.</u>	<u>Filed By</u>	<u>Public?</u>
08/04/2014	Mercedes' Petition for Inter Partes Review of '781 Claims 31-32	Petition	1	Petitioner	Yes
08/04/2014	Power of Attorney	Power of Attorney	2	Petitioner	Yes
08/04/2014	'781 Patent	Exhibit	1001	Petitioner	Yes

08/04/2014	'781 Patent File History	Exhibit	1002	Petitioner	Yes
08/04/2014	US4901701 (Chasteen) (Cited Reference)	Exhibit	1003	Petitioner	Yes
08/04/2014	US5708584 (Doi) (Cited Reference)	Exhibit	1004	Petitioner	Yes
08/04/2014	EP0392953 (Tresse)	Exhibit	1005	Petitioner	Yes
08/04/2014	US5357438 (Davidian)	Exhibit	1006	Petitioner	Yes
08/04/2014	WO91/07672 (Montague)	Exhibit	1007	Petitioner	Yes
08/04/2014	EP0549909 (Kajiwata) (Secondary Reference)	Exhibit	1008	Petitioner	Yes
08/04/2014	WO96/02853 (Tonkin) (Secondary Reference)	Exhibit	1009	Petitioner	Yes
08/04/2014	Declaration of Dr. Chris G. Bartone in Support of Mercedes' Petition	Exhibit	1010	Petitioner	Yes
08/04/2014	CV of Dr. Chris G. Bartone	Exhibit	1011	Petitioner	Yes
08/14/2014	Notice of Filing Date Accorded to Petition	Notice of Filing Date	3	Board	Yes
08/20/2014	Petitioner's Notice of Compliance and Transmittal of Corrected Petition	Notice	4	Petitioner	Yes
08/20/2014	Corrected Petition for Inter Partes Review	Notice	5	Petitioner	Yes
08/27/2014	Related Matters	Notice	6	Potential Patent Owner	Yes
08/29/2014	Certificate of Service for the Mandatory Notice	Notice	7	Patent Owner	Yes
09/08/2014	Notice of Accepting Corrected Petition	Order	8	Board	Yes
11/04/2014	Velocity IPR Preliminary Response	Preliminary Response	9	Patent Owner	Yes
11/21/2014	Kurz motion for pro hac vice admission	Motion	10	Petitioner	Yes
12/02/2014	Motion for the Pro Hac Vice Admission of James A. Shimota under 37 CFR 42.10	Motion	11	Patent Owner	Yes
12/02/2014	Exhibit A James A. Shimota Biography	Exhibit	1001	Patent Owner	No
12/15/2014	Order Conduct of the Proceeding	Order	12	Board	Yes
12/16/2014	ORDER Granting Petitioners's Motion for Pro Hac Vice Admission Kurz	Notice	13	Board	Yes
12/16/2014	ORDER Granting Patent Owner's Motion for Pro Hac Vice Admission of Shimota	Notice	14	Board	Yes
12/18/2014	IPR Request Per 12-15 Order	Motion	15	Patent Owner	Yes
12/18/2014	Exhibit 2001 Statutory Disclaimer	Exhibit	2001	Patent Owner	Yes
12/19/2014	Order-Conduct of Proceeding	Order	16	Board	Yes
12/22/2014	Expunged	Motion	17	Patent	Yes

12/23/2014	Order Conduct of the Proceeding	Notice	18	Owner Board	Yes
12/29/2014	Request	Motion	19	Patent Owner	Yes
01/06/2015	Judgment - Request for Adverse Judgment - 37 CFR 42.73(b)	Request for Adverse Judgment Before Institution	20	Board	Yes
01/20/2015	Request for Refund of Post-Institution Fees	Refund Request	21	Petitioner	Yes
01/28/2015	Expunged	Notice	22	Board	Yes
01/28/2015	Notice of Refund	Notice	23	Board	Yes

---

Copyright © 2015 LexisNexis CourtLink, Inc. All rights reserved.  
 \*\*\* THIS DATA IS FOR INFORMATIONAL PURPOSES ONLY \*\*\*



---

**US District Court Civil Docket**

U.S. District - Illinois Northern  
(Chicago)

**1:13cv8413**

**Velocity Patent Llc v. Mercedes-Benz USA, Llc et al**

**This case was retrieved from the court on Monday, March 23, 2015**

---

Date Filed: **11/21/2013**

Assigned To: **Honorable John W. Darrah**

Referred To:

Class Code: **OPEN**

Closed:

Nature of suit: **Patent (830)**

Statute: **35:271**

Cause: **Patent Infringement**

Jury Demand: **Plaintiff**

Lead Docket: **None**

Demand Amount: **\$0**

Other Docket: **1:13cv08419**

NOS Description: **Patent**

**1:13cv08416**

**1:13cv08418**

Jurisdiction: **Federal Question**

**Litigants**

**Attorneys**

Velocity Patent Llc  
Plaintiff

Aaron Charles Taggart  
ATTORNEY TO BE NOTICED  
Mavrakakis Law Group LLP  
180 N. Lasalle Suite 2215  
Chicago , IL 60601  
USA  
(312) 216-1627  
Email:Ataggart@mavllp.Com

Adam Robert Brausa  
ATTORNEY TO BE NOTICED  
[Term: 06/02/2014]  
Mavrakakis Law Group LLP  
180 North Lasalle Street Suite 2215  
Chicago , IL 60601  
USA  
(312) 216-1626  
Email:Abrausa@mavllp.Com

Howard E Levin  
ATTORNEY TO BE NOTICED  
Mavrakakis Law Group LLP  
180 N. Lasalle Suite 2215  
Chicago , IL 60601  
USA  
312-216-1620  
Fax: (630) 881-7438  
Email:Hlevin@mavllp.Com

Mercedes-Benz USA, Llc  
Defendant

James A Shimota  
ATTORNEY TO BE NOTICED  
Mavrakakis Law Group LLP  
180 N. Lasalle Suite 2215  
Chicago , IL 60601  
USA  
(312) 216-1626  
Fax: (773)661-2555  
Email:Jshimota@mavllp.Com

Celine J Crowson  
LEAD ATTORNEY;PRO HAC VICE;ATTORNEY TO BE  
NOTICED  
Hogan Lovells Us Llp  
555 13th Street, Nw  
Washington , DC 20004  
USA  
(202) 637-5600  
Email:Celine.Crowson@hoganlovells.Com

Anand C. Mathew  
ATTORNEY TO BE NOTICED  
Schopf & Weiss LLP  
One South Wacker Drive 28th Floor  
Chicago , IL 60606  
USA  
(312) 701-9300  
Email:Mathew@sw.Com

David L DeBruin  
ATTORNEY TO BE NOTICED  
Schopf & Weiss LLP  
One South Wacker Drive 28th Floor  
Chicago , IL 60606  
USA  
(312)701-9300  
Email:Debruin@sw.Com

Joseph James Raffetto  
PRO HAC VICE;ATTORNEY TO BE NOTICED  
Hogan Lovells  
555 13th Street Nw  
Washington , DC 20004  
USA  
(202) 637-5514  
Email:Joseph.Raffetto@hoganlovells.Com

Raymond A Kurz  
PRO HAC VICE;ATTORNEY TO BE NOTICED  
Hogan Lovells Us Llp  
555 Thirteenth Street  
Nw  
Washington , DC 20004  
USA  
(202) 637-5600  
Email:Raymond.Kurz@hoganlovells.Com

Robert J. Weinschenk  
PRO HAC VICE  
[Term: 02/24/2014]

Hogan Lovells Us Llp  
555 13th Street, Nw  
Washington , DC 20004  
USA  
(202) 637-5600  
Email:Robert.Weinschenk@hoganlovells.Com

Steven A. Weiss  
ATTORNEY TO BE NOTICED  
Schopf & Weiss LLP  
One South Wacker Drive 28th Floor  
Chicago , IL 60606  
USA  
(312) 701-9300  
Email:Weiss@sw.Com

Mercedes-Benz U.S. International Inc.  
Defendant

Celine J Crowson  
LEAD ATTORNEY;PRO HAC VICE;ATTORNEY TO BE  
NOTICED  
Hogan Lovells Us Llp  
555 13th Street, Nw  
Washington , DC 20004  
USA  
(202) 637-5600  
Email:Celine.Crowson@hoganlovells.Com

Anand C. Mathew  
ATTORNEY TO BE NOTICED  
Schopf & Weiss LLP  
One South Wacker Drive 28th Floor  
Chicago , IL 60606  
USA  
(312) 701-9300  
Email:Mathew@sw.Com

David L DeBruin  
ATTORNEY TO BE NOTICED  
Schopf & Weiss LLP  
One South Wacker Drive 28th Floor  
Chicago , IL 60606  
USA  
(312)701-9300  
Email:Debruin@sw.Com

Joseph James Raffetto  
PRO HAC VICE;ATTORNEY TO BE NOTICED  
Hogan Lovells  
555 13th Street Nw  
Washington , DC 20004  
USA  
(202) 637-5514  
Email:Joseph.Raffetto@hoganlovells.Com

Raymond A Kurz  
PRO HAC VICE;ATTORNEY TO BE NOTICED  
Hogan Lovells Us Llp  
555 Thirteenth Street  
Nw  
Washington , DC 20004  
USA

(202) 637-5600  
Email:Raymond.Kurz@hoganlovells.Com

Robert J. Weinschenk  
PRO HAC VICE  
[Term: 02/24/2014]  
Hogan Lovells Us Llp  
555 13th Street, Nw  
Washington , DC 20004  
USA  
(202) 637-5600  
Email:Robert.Weinschenk@hoganlovells.Com

Steven A. Weiss  
ATTORNEY TO BE NOTICED  
Schopf & Weiss LLP  
One South Wacker Drive 28th Floor  
Chicago , IL 60606  
USA  
(312) 701-9300  
Email:Weiss@sw.Com

Bmw of North America, Llc  
Respondent

Bmw Manufacturing Co., Llc  
Respondent

Mercedes-Benz U.S. International Inc.  
Counter Claimant

Celine J Crowson  
LEAD ATTORNEY;ATTORNEY TO BE NOTICED  
Hogan Lovells Us Llp  
555 13th Street, Nw  
Washington , DC 20004  
USA  
(202) 637-5600  
Email:Celine.Crowson@hoganlovells.Com

Anand C. Mathew  
ATTORNEY TO BE NOTICED  
Schopf & Weiss LLP  
One South Wacker Drive 28th Floor  
Chicago , IL 60606  
USA  
(312) 701-9300  
Email:Mathew@sw.Com

David L DeBruin  
ATTORNEY TO BE NOTICED  
Schopf & Weiss LLP  
One South Wacker Drive 28th Floor  
Chicago , IL 60606  
USA  
(312)701-9300  
Email:Debruin@sw.Com

Joseph James Raffetto  
PRO HAC VICE;ATTORNEY TO BE NOTICED  
Hogan Lovells  
555 13th Street Nw  
Washington , DC 20004

USA  
(202) 637-5514  
Email:Joseph.Raffetto@hoganlovells.Com

Raymond A Kurz  
ATTORNEY TO BE NOTICED  
Hogan Lovells Us Llp  
555 Thirteenth Street  
Nw  
Washington , DC 20004  
USA  
(202) 637-5600  
Email:Raymond.Kurz@hoganlovells.Com

Robert J. Weinschenk  
[Term: 02/24/2014]  
Hogan Lovells Us Llp  
555 13th Street, Nw  
Washington , DC 20004  
USA  
(202) 637-5600  
Email:Robert.Weinschenk@hoganlovells.Com

Steven A. Weiss  
ATTORNEY TO BE NOTICED  
Schopf & Weiss LLP  
One South Wacker Drive 28th Floor  
Chicago , IL 60606  
USA  
(312) 701-9300  
Email:Weiss@sw.Com

Velocity Patent Llc  
Counter Defendant

Aaron Charles Taggart  
ATTORNEY TO BE NOTICED  
Mavrakakis Law Group LLP  
180 N. Lasalle Suite 2215  
Chicago , IL 60601  
USA  
(312) 216-1627  
Email:Ataggart@mavllp.Com

Adam Robert Brausa  
ATTORNEY TO BE NOTICED  
[Term: 06/02/2014]  
Mavrakakis Law Group LLP  
180 North Lasalle Street Suite 2215  
Chicago , IL 60601  
USA  
(312) 216-1626  
Email:Abrausa@mavllp.Com

Howard E Levin  
ATTORNEY TO BE NOTICED  
Mavrakakis Law Group LLP  
180 N. Lasalle Suite 2215  
Chicago , IL 60601  
USA  
312-216-1620  
Fax: (630) 881-7438  
Email:Hlevin@mavllp.Com

Mercedes-Benz USA, Llc  
Counter Claimant

James A Shimota  
ATTORNEY TO BE NOTICED  
Mavrakakis Law Group LLP  
180 N. Lasalle Suite 2215  
Chicago , IL 60601  
USA  
(312) 216-1626  
Fax: (773)661-2555  
Email:Jshimota@mavllp.Com

Celine J Crowson  
LEAD ATTORNEY;ATTORNEY TO BE NOTICED  
Hogan Lovells Us Llp  
555 13th Street, Nw  
Washington , DC 20004  
USA  
(202) 637-5600  
Email:Celine.Crowson@hoganlovells.Com

Anand C. Mathew  
ATTORNEY TO BE NOTICED  
Schopf & Weiss LLP  
One South Wacker Drive 28th Floor  
Chicago , IL 60606  
USA  
(312) 701-9300  
Email:Mathew@sw.Com

David L DeBruin  
ATTORNEY TO BE NOTICED  
Schopf & Weiss LLP  
One South Wacker Drive 28th Floor  
Chicago , IL 60606  
USA  
(312)701-9300  
Email:Debruin@sw.Com

Joseph James Raffetto  
PRO HAC VICE;ATTORNEY TO BE NOTICED  
Hogan Lovells  
555 13th Street Nw  
Washington , DC 20004  
USA  
(202) 637-5514  
Email:Joseph.Raffetto@hoganlovells.Com

Raymond A Kurz  
ATTORNEY TO BE NOTICED  
Hogan Lovells Us Llp  
555 Thirteenth Street  
Nw  
Washington , DC 20004  
USA  
(202) 637-5600  
Email:Raymond.Kurz@hoganlovells.Com

Robert J. Weinschenk  
[Term: 02/24/2014]  
Hogan Lovells Us Llp

555 13th Street, Nw  
Washington , DC 20004  
USA  
(202) 637-5600  
Email:Robert.Weinschenk@hoganlovells.Com

Steven A. Weiss  
ATTORNEY TO BE NOTICED  
Schopf & Weiss LLP  
One South Wacker Drive 28th Floor  
Chicago , IL 60606  
USA  
(312) 701-9300  
Email:Weiss@sw.Com

Velocity Patent Llc  
Counter Defendant

Aaron Charles Taggart  
ATTORNEY TO BE NOTICED  
Mavrakakis Law Group LLP  
180 N. Lasalle Suite 2215  
Chicago , IL 60601  
USA  
(312) 216-1627  
Email:Ataggart@mavllp.Com

Adam Robert Brausa  
ATTORNEY TO BE NOTICED  
[Term: 06/02/2014]  
Mavrakakis Law Group LLP  
180 North Lasalle Street Suite 2215  
Chicago , IL 60601  
USA  
(312) 216-1626  
Email:Abrausa@mavllp.Com

Howard E Levin  
ATTORNEY TO BE NOTICED  
Mavrakakis Law Group LLP  
180 N. Lasalle Suite 2215  
Chicago , IL 60601  
USA  
312-216-1620  
Fax: (630) 881-7438  
Email:Hlevin@mavllp.Com

James A Shimota  
ATTORNEY TO BE NOTICED  
Mavrakakis Law Group LLP  
180 N. Lasalle Suite 2215  
Chicago , IL 60601  
USA  
(312) 216-1626  
Fax: (773)661-2555  
Email:Jshimota@mavllp.Com

Date	#	Proceeding Text	Source
11/21/2013	1	COMPLAINT filed by Velocity Patent LLC; Jury Demand. Filing fee \$ 400, receipt number 0752-8957333. (Attachments: # 1 Exhibit Ex. A)(Shimota, James) (Entered: 11/21/2013)	

- 11/21/2013 2 ATTORNEY Appearance for Plaintiff Velocity Patent LLC by James A Shimota (Shimota, James) (Entered: 11/21/2013)
- 11/21/2013 3 CIVIL Cover Sheet (Shimota, James) (Entered: 11/21/2013)
- 11/21/2013 CASE ASSIGNED to the Honorable Samuel Der-Yeghiayan. Designated as Magistrate Judge the Honorable Michael T. Mason. (nsf, ) (Entered: 11/21/2013)
- 11/21/2013 4 ATTORNEY Appearance for Plaintiff Velocity Patent LLC by Howard E Levin (Levin, Howard) (Entered: 11/21/2013)
- 11/21/2013 5 ATTORNEY Appearance for Plaintiff Velocity Patent LLC by Adam Robert Brausa (Brausa, Adam) (Entered: 11/21/2013)
- 11/21/2013 SUMMONS Issued as to Defendants Mercedes-Benz U.S. International Inc., Mercedes-Benz USA, LLC (pg, ) (Entered: 11/21/2013)
- 11/21/2013 6 NOTIFICATION of Affiliates pursuant to Local Rule 3.2 by Velocity Patent LLC (Shimota, James) (Entered: 11/21/2013)
- 11/21/2013 7 Rule 3.4 Notice of Claims Involving Patents by Velocity Patent LLC (Shimota, James) (Entered: 11/21/2013)
- 11/25/2013 8 MINUTE entry before the Honorable Samuel Der-Yeghiayan: The Clerk of Court is to arrange for this case to be transferred to the Patent Case Pilot Program. Mailed notice (mw, ) (Entered: 11/25/2013)
- 11/25/2013 9 MAILED patent report to Patent Trademark Office, Alexandria VA. (mb, ) (Entered: 11/25/2013)
- 11/26/2013 10 EXECUTIVE COMMITTEE ORDER: It appearing that 13 C 8413, Velocity Patent LLC v. Mercedes-Benz USA LLC, et al., pending before the Hon. Samuel Der-Yeghiayan, has been identified for transfer to the Patent Case Pilot Program in which this Court is participating, therefore It is hereby ordered that 13 C 8413, Velocity Patent LLC v. Mercedes-Benz USA LLC, et al., is to be reassigned by lot to one of the district judges participating in the pilot program. Case reassigned to the Honorable John W. Darrah for all further proceedings. Signed by Executive Committee on 11/26/2013. (td, ) (Entered: 11/26/2013)
- 12/02/2013 11 SUMMONS Returned Executed by Velocity Patent LLC as to Mercedes-Benz USA, LLC on 11/22/2013, answer due 12/13/2013. (Shimota, James) (Entered: 12/02/2013)
- 12/04/2013 12 ATTORNEY Appearance for Plaintiff Velocity Patent LLC by Aaron Charles Taggart (Taggart, Aaron) (Entered: 12/04/2013)
- 12/04/2013 13 SUMMONS Returned Executed by Velocity Patent LLC as to Mercedes-Benz U.S. International Inc. on 11/22/2013, answer due 12/13/2013. (Shimota, James) (Entered: 12/04/2013)
- 12/04/2013 14 order: Initial status hearing set for January 21, 2014, at 9:30 a.m. Signed by the Honorable John W. Darrah on 12/4/2013:(mb, ) (Entered: 12/05/2013)
- 12/11/2013 15 ATTORNEY Appearance for Defendants Mercedes-Benz U.S. International Inc., Mercedes-Benz USA, LLC by Anand C. Mathew (Mathew, Anand) (Entered: 12/11/2013)
- 12/11/2013 16 ATTORNEY Appearance for Defendants Mercedes-Benz U.S. International Inc., Mercedes-Benz USA, LLC by David L DeBruin (DeBruin, David) (Entered: 12/11/2013)
- 12/11/2013 17 ATTORNEY Appearance for Defendants Mercedes-Benz U.S. International Inc., Mercedes-Benz USA, LLC by Steven A. Weiss (Weiss, Steven) (Entered: 12/11/2013)
- 12/11/2013 18 MOTION by Defendants Mercedes-Benz U.S. International Inc., Mercedes-Benz USA, LLC for extension of time to file Unopposed Motion for Extension of Time to Respond to Plaintiff's Complaint (Mathew, Anand)



- (Entered: 12/11/2013)
- 12/11/2013 19 NOTICE of Motion by Anand C. Mathew for presentment of motion for extension of time to file 18 before Honorable John W. Darrah on 1/8/2014 at 09:30 AM. (Mathew, Anand) (Entered: 12/11/2013)
- 12/13/2013 20 ORDER Defendants' Unopposed Motion for an Extension of Time to Answer or Otherwise Plead 18 is granted. Defendants to file their responsive pleadings on or before January 27, 2014. No appearance is necessary on January 8, 2014. The initial status hearing of January 21, 2014, is reset to January 28, 2014, at 9:30 a.m. Signed by the Honorable John W. Darrah on 12/13/2013: (mb, ) (Entered: 12/16/2013)
- 12/16/2013 21 MOTION for Leave to Appear Pro Hac Vice Filing fee \$ 50, receipt number 0752-9029306. (Kurz, Raymond) (Entered: 12/16/2013)
- 12/16/2013 22 MOTION for Leave to Appear Pro Hac Vice Filing fee \$ 50, receipt number 0752-9029608. (Crowson, Celine) (Entered: 12/16/2013)
- 12/16/2013 23 SUMMONS Returned Executed by Velocity Patent LLC (Shimota, James) (Entered: 12/16/2013)
- 12/16/2013 24 MOTION for Leave to Appear Pro Hac Vice Filing fee \$ 50, receipt number 0752-9029764. (Weinschenk, Robert) (Entered: 12/16/2013)
- 12/20/2013 25 NOTIFICATION of Affiliates pursuant to Local Rule 3.2 by Mercedes-Benz USA, LLC and Corporate Disclosure Statement (Mathew, Anand) (Entered: 12/20/2013)
- 12/20/2013 26 NOTIFICATION of Affiliates pursuant to Local Rule 3.2 by Mercedes-Benz U.S. International Inc. and Corporate Disclosure Statement (Mathew, Anand) (Entered: 12/20/2013)
- 12/30/2013 27 MOTION by Plaintiff Velocity Patent LLC to reassign case (Attachments: # 1 Exhibit A, # 2 Exhibit B, # 3 Exhibit C, # 4 Exhibit D)(Shimota, James) (Entered: 12/30/2013)
- 12/30/2013 28 NOTICE of Motion by James A Shimota for presentment of motion to reassign case 27 before Honorable John W. Darrah on 1/7/2013 at 09:30 AM. (Shimota, James) (Entered: 12/30/2013)
- 12/31/2013 29 NOTICE of Motion by James A Shimota for presentment of motion to reassign case 27 before Honorable John W. Darrah on 1/7/2014 at 09:30 AM. (Shimota, James) (Entered: 12/31/2013)
- 01/06/2014 30 RESPONSE by Defendants Mercedes-Benz U.S. International Inc., Mercedes-Benz USA, LLC to motion to reassign case 27 (Mathew, Anand) (Entered: 01/06/2014)
- 01/07/2014 31 ORDER Entered by the Honorable John W. Darrah: Pro hac vice motions are granted [21, 22, 24]. Mailed notice (tjm) (Entered: 01/08/2014)
- 01/07/2014 32 ORDER Entered by the Honorable John W. Darrah on 1/7/2014: Plaintiff's motion to reassign cases is granted in part 27 . 13 C 8419 and 13 C 8421 will be reassigned to this Courts calendar. 13 C 8416 and 13 C 8418 will not be reassigned at this time. Objections/responses for 13 C 8416 and 13 C 8418 to be filed by 1/29/14, reply by 2/5/14. Status hearing set for 1/28/14 is re-set to 4/10/14 at 9:30 a.m. Mailed notice (tjm) (Entered: 01/08/2014)
- 01/23/2014 33 - BMW of North America, LLC & BMW Manufacturing Co., LLC's Response to Velocity's Motion to Reassign - by BMW of North America, LLC, BMW Manufacturing Co., LLC (Reynolds, Steven) (Entered: 01/23/2014)
- 01/27/2014 34 Mercedes-Benz U.S. International, Inc.'s ANSWER to Complaint Affirmative Defenses, and COUNTERCLAIM filed by Mercedes-Benz U.S. International Inc. against Velocity Patent LLC . by Mercedes-Benz U.S. International Inc. (Weiss, Steven) (Entered: 01/27/2014)

- 01/27/2014 35 Mercedes-Benz USA, LLC's ANSWER to Complaint Affirmative Defenses, and COUNTERCLAIM filed by Mercedes-Benz USA, LLC against Velocity Patent LLC . by Mercedes-Benz USA, LLC(Weiss, Steven) (Entered: 01/27/2014)
- 01/29/2014 36 ATTORNEY Appearance for Objectors Audi of America, Inc., Audi of America, LLC by Jeffrey Mark Drake NON-PARTY (Drake, Jeffrey) (Entered: 01/29/2014)
- 01/29/2014 37 ATTORNEY Appearance for Objectors Audi of America, Inc., Audi of America, LLC by Ryan Christopher Williams NON-PARTY (Williams, Ryan) (Entered: 01/29/2014)
- 01/29/2014 38 RESPONSE by Objectors Audi of America, Inc., Audi of America, LLC to notice of motion 29 and Motion to Reassign (dkt no 27) (Williams, Ryan) (Entered: 01/29/2014)
- 01/31/2014 39 REPLY by Velocity Patent LLC to Response 38 (Shimota, James) (Entered: 01/31/2014)
- 02/04/2014 40 NOTICE by James A Shimota of Change of Address (Shimota, James) (Entered: 02/04/2014)
- 02/04/2014 41 NOTICE by Howard E Levin of Change of Address (Levin, Howard) (Entered: 02/04/2014)
- 02/04/2014 42 NOTICE by Aaron Charles Taggart of Change of Address (Taggart, Aaron) (Entered: 02/04/2014)
- 02/04/2014 43 NOTICE by Adam Robert Brausa of Change of Address (Brausa, Adam) (Entered: 02/04/2014)
- 02/18/2014 44 ANSWER to counterclaim by Velocity Patent LLC(Shimota, James) (Entered: 02/18/2014)
- 02/18/2014 45 ANSWER to counterclaim by Velocity Patent LLC(Shimota, James) (Entered: 02/18/2014)
- 02/20/2014 46 MOTION by counsel for Defendants Mercedes-Benz U.S. International Inc., Mercedes-Benz USA, LLC, Counter Claimants Mercedes-Benz U.S. International Inc., Mercedes-Benz USA, LLC to withdraw as attorney Unopposed Motion to Withdraw as Attorney of Record (DeBruin, David) (Entered: 02/20/2014)
- 02/20/2014 47 NOTICE of Motion by David L DeBruin for presentment of motion to withdraw as attorney, 46 before Honorable John W. Darrah on 2/26/2014 at 09:30 AM. (DeBruin, David) (Entered: 02/20/2014)
- 02/24/2014 48 MINUTE entry before the Honorable John W. Darrah: Defendants' motion to allow Robert J. Weinschenk to withdraw as attorney of record 46 is granted. No appearances necessary on February 26, 2014. Status hearing set for April 10, 2014, at 9:30 a.m. remains as scheduled. Mailed notice (maf) (Entered: 02/24/2014)
- 04/03/2014 49 NOTICE by David L DeBruin of Change of Address (DeBruin, David) (Entered: 04/03/2014)
- 04/03/2014 50 REPORT of Rule 26(f) Planning Meeting (Attachments: # 1 Exhibit 1) (Shimota, James) (Entered: 04/03/2014)
- 04/10/2014 51 ORDER: Status hearing held and continued to 4/17/14 at 9:30 a.m. Joint claim construction chart and status report to be filed by 2/15/15. Claim construction hearing is set for 3/11/15 at 1:30 p.m. Signed by the Honorable John W. Darrah on 4/10/2014. Mailed notice. (et, ) (Entered: 04/10/2014)
- 04/11/2014 52 MINUTE entry before the Honorable John W. Darrah: The Court's 4/10/14 order is amended to reflect the following: Joint claim construction chart and status report to be filed by 2/25/15. Mailed notice(maf) (Entered: 04/11/2014)

- 04/17/2014 53 MINUTE entry before the Honorable John W. Darrah: Status hearing held and continued to 4/24/14 at 9:30 a.m. Opinion to follow. Counsel for BMW in case 13 C 8416, and counsel for Audi in 13 C 8418 shall be present at the 4/24/14 status. Plaintiff shall notify them of the 4/24/14 date. Mailed notice(maf) (Entered: 04/17/2014)
- 04/23/2014 54 TRANSCRIPT OF PROCEEDINGS held on 04/10/14 before the Honorable John W. Darrah. Court Reporter Contact Information: Mary M. Hacker, (312) 435-5564, Mary\_Hacker@ilnd.uscourts.gov. IMPORTANT: The transcript may be viewed at the court's public terminal or purchased through the Court Reporter/Transcriber before the deadline for Release of Transcript Restriction. After that date it may be obtained through the Court Reporter/Transcriber or PACER. For further information on the redaction process, see the Court's web site at www.ilnd.uscourts.gov under Quick Links select Policy Regarding the Availability of Transcripts of Court Proceedings. Redaction Request due 5/14/2014. Redacted Transcript Deadline set for 5/26/2014. Release of Transcript Restriction set for 7/22/2014. (Hacker, Mary) (Entered: 04/23/2014)
- 04/24/2014 55 ORDER: Status hearing and ruling on motion hearing held. For the reasons stated in the attached memorandum opinion and order, the Audi case and the Mercedes-Benz case are deemed related, and all conditions of reassignment required by Local Rule 40.4(b) are met. Velocity's Motion to Reassign is granted. Case No. 1:13-cv-8416, Velocity Patent LLC v. BMW of North America, LLC; Case No. 1:13-cv-8418, Velocity Patent LLC v. Audi of America, Inc.; Case No. 1:13-cv- 8419, Velocity Patent LLC v. Chrysler Group, LLC; and Case No. 1:13-cv-8421, Velocity Patent LLC v. Jaguar Land Rover North America, LLC, are reassigned to Judge Darrah. Enter Memorandum Opinion and Order. Status hearing set for 5/7/14 at 9:30 a.m. Signed by the Honorable John W. Darrah on 4/24/2014. Mailed notice (td, ) (Entered: 04/25/2014)
- 04/24/2014 56 MEMORANDUM Opinion and Order Signed by the Honorable John W. Darrah on 4/24/2014. Mailed notice (td, ) (Entered: 04/25/2014)
- 05/07/2014 57 MINUTE entry before the Honorable John W. Darrah: Status hearing held and continued to 8/19/14 at 9:30 a.m. Mailed notice(maf) (Entered: 05/07/2014)
- 05/12/2014 58 MOTION for Leave to Appear Pro Hac Vice Filing fee \$ 50, receipt number 0752-9472073. (Raffetto, Joseph) (Entered: 05/12/2014)
- 05/21/2014 59 TRANSCRIPT OF PROCEEDINGS held on 05/07/14 before the Honorable John W. Darrah. Court Reporter Contact Information: Mary M. Hacker, (312) 435-5564, Mary\_Hacker@ilnd.uscourts.gov. IMPORTANT: The transcript may be viewed at the court's public terminal or purchased through the Court Reporter/Transcriber before the deadline for Release of Transcript Restriction. After that date it may be obtained through the Court Reporter/Transcriber or PACER. For further information on the redaction process, see the Court's web site at www.ilnd.uscourts.gov under Quick Links select Policy Regarding the Availability of Transcripts of Court Proceedings. Redaction Request due 6/11/2014. Redacted Transcript Deadline set for 6/23/2014. Release of Transcript Restriction set for 8/19/2014. (Hacker, Mary) (Entered: 05/21/2014)
- 05/30/2014 60 MOTION by counsel for Plaintiff Velocity Patent LLC to withdraw as attorney Adam R. Brausa (Shimota, James) (Entered: 05/30/2014)
- 05/30/2014 61 NOTICE of Motion by James A Shimota for presentment of motion to withdraw as attorney 60 before Honorable John W. Darrah on 6/5/2014 at 09:30 AM. (Shimota, James) (Entered: 05/30/2014)
- 06/02/2014 62 ORDER: Plaintiff's Motion to Withdraw Counsel Adam R. Brausa [ 60 ] is granted. No appearances necessary on June 5, 2014. Pro hac vice motion is granted [ 58 ]. All other dates remain as scheduled. Signed by the Honorable John W. Darrah on 6/2/2014. Mailed notice. (et, ) (Entered: 06/02/2014)

- 06/03/2014)
- 08/15/2014 63 MOTION by Defendants Mercedes-Benz U.S. International Inc., Mercedes-Benz USA, LLC, Counter Claimants Mercedes-Benz U.S. International Inc., Mercedes-Benz USA, LLC for joinder in Motion to Stay (D.E. 85 filed in Case No. 1:13-cv-08418) (Mathew, Anand) (Entered: 08/15/2014)
- 08/15/2014 64 NOTICE of Motion by Anand C. Mathew for presentment of motion for joinder, 63 before Honorable John W. Darrah on 8/21/2014 at 09:30 AM. (Mathew, Anand) (Entered: 08/15/2014)
- 08/18/2014 65 EXHIBIT by Defendants Mercedes-Benz U.S. International Inc., Mercedes-Benz USA, LLC, Counter Claimants Mercedes-Benz U.S. International Inc., Mercedes-Benz USA, LLC regarding MOTION by Defendants Mercedes-Benz U.S. International Inc., Mercedes-Benz USA, LLC for joinder in Motion to Stay (D.E. 85 filed in Case No. 1:13-cv-08418) 63 (Attachments: # 1 Exhibit A, # 2 Exhibit B, # 3 Exhibit C)(Mathew, Anand) (Entered: 08/18/2014)
- 08/19/2014 66 ORDER: Status hearing and ruling on motion hearing held. Defendants' motion for joinder in motion to stay (D.E. 85 filed in Case No. 1:13-cv-08418) is granted 63 . No appearance is needed on 8/21/14. Status hearing set for 9/16/14 at 9:30 a.m. for rescheduling the remainder of the case. Signed by the Honorable John W. Darrah on 8/19/2014. (jh, ) (Entered: 08/20/2014)
- 09/03/2014 67 RESPONSE by Counter Defendants Velocity Patent LLC, Velocity Patent LLC, Plaintiff Velocity Patent LLC to notice of motion 64 in Opposition to Notice of Joinder (Shimota, James) (Entered: 09/03/2014)
- 09/11/2014 68 TRANSCRIPT OF PROCEEDINGS held on 08/19/14 before the Honorable John W. Darrah. Court Reporter Contact Information: Mary M. Hacker, (312) 435-5564, Mary\_Hacker@ilnd.uscourts.gov. IMPORTANT: The transcript may be viewed at the court's public terminal or purchased through the Court Reporter/Transcriber before the deadline for Release of Transcript Restriction. After that date it may be obtained through the Court Reporter/Transcriber or PACER. For further information on the redaction process, see the Court's web site at www.ilnd.uscourts.gov under Quick Links select Policy Regarding the Availability of Transcripts of Court Proceedings. Redaction Request due 10/2/2014. Redacted Transcript Deadline set for 10/13/2014. Release of Transcript Restriction set for 12/10/2014. (Hacker, Mary) (Entered: 09/11/2014)
- 09/16/2014 69 MINUTE entry before the Honorable John W. Darrah: Status hearing held and continued to 3/31/15 at 9:30 a.m. Claim construction hearing set for 3/11/15 is vacated. Mailed notice(maf) (Entered: 09/16/2014)
- 11/04/2014 70 MINUTE entry before the Honorable John W. Darrah: In court hearing set for 11/6/14 at 9:30 a.m. Mailed notice(maf) (Entered: 11/04/2014)
- 11/04/2014 71 ORDER: Status hearing set for November 6, 2014 at 9:30 a.m. Signed by the Honorable John W. Darrah on 11/4/2014. (jh, ) (Entered: 11/04/2014)
- 11/06/2014 72 MINUTE entry before the Honorable John W. Darrah: Status hearing held. Parties shall email the courtroom deputy an order to stay, forthwith. Mailed notice(maf) (Entered: 11/06/2014)
- 11/14/2014 73 ORDER: Enter stipulated order to stay proceedings. Signed by the Honorable John W. Darrah on 11/14/2014. (jh, ) (Entered: 11/14/2014)
- 11/14/2014 74 STIPULATED ORDER signed by the Honorable John W. Darrah on 11/14/2014. (jh, ) (Entered: 11/14/2014)
- 12/08/2014 75 TRANSCRIPT OF PROCEEDINGS held on 11/06/14 before the Honorable John W. Darrah. Court Reporter Contact Information: Mary M. Hacker, (312) 435-5564, Mary\_Hacker@ilnd.uscourts.gov. IMPORTANT: The transcript may be viewed at the court's public terminal or purchased

through the Court Reporter/Transcriber before the deadline for Release of Transcript Restriction. After that date it may be obtained through the Court Reporter/Transcriber or PACER. For further information on the redaction process, see the Court's web site at [www.ilnd.uscourts.gov](http://www.ilnd.uscourts.gov) under Quick Links select Policy Regarding the Availability of Transcripts of Court Proceedings. Redaction Request due 12/29/2014. Redacted Transcript Deadline set for 1/8/2015. Release of Transcript Restriction set for 3/9/2015. (Hacker, Mary) (Entered: 12/08/2014)

- 02/25/2015 76 TRANSCRIPT OF PROCEEDINGS held on 9/16/14 before the Honorable John W. Darrah. Court Reporter Contact Information: Jennifer Dunn, CSR, RMR, CRR, CLVS Real-Time Reporters, Inc. Jennifer@Real-TimeReporters.com 79 West Monroe Street, Suite 1324 Chicago, IL 60603 (312)578-9323. IMPORTANT: The transcript may be viewed at the court's public terminal or purchased through the Court Reporter/Transcriber before the deadline for Release of Transcript Restriction. After that date it may be obtained through the Court Reporter/Transcriber or PACER. For further information on the redaction process, see the Court's web site at [www.ilnd.uscourts.gov](http://www.ilnd.uscourts.gov) under Quick Links select Policy Regarding the Availability of Transcripts of Court Proceedings. Redaction Request due 3/18/2015. Redacted Transcript Deadline set for 3/30/2015. Release of Transcript Restriction set for 5/26/2015. (rp, ) (Entered: 03/02/2015)

---

Copyright © 2015 LexisNexis CourtLink, Inc. All rights reserved.  
\*\*\* THIS DATA IS FOR INFORMATIONAL PURPOSES ONLY \*\*\*

---

**US District Court Civil Docket**

U.S. District - Illinois Northern  
(Chicago)

**1:13cv8416**

**Velocity Patent Llc v. Bmw of North America, Llc et al**

**This case was retrieved from the court on Monday, March 23, 2015**

---

<b>Date Filed:</b> 11/21/2013	<b>Class Code:</b> CLOSED
<b>Assigned To:</b> Honorable John W. Darrah	<b>Closed:</b> 08/12/2014
<b>Referred To:</b>	<b>Statute:</b> 35:271
<b>Nature of suit:</b> Patent (830)	<b>Jury Demand:</b> Both
<b>Cause:</b> Patent Infringement	<b>Demand Amount:</b> \$0
<b>Lead Docket:</b> None	<b>NOS Description:</b> Patent
<b>Other Docket:</b> 1:13cv08413	
<b>Jurisdiction:</b> Federal Question	

**Litigants**

Velocity Patent Llc  
Plaintiff

**Attorneys**

James A Shimota  
LEAD ATTORNEY;ATTORNEY TO BE NOTICED  
Mavrakakis Law Group LLP  
180 N. Lasalle Suite 2215  
Chicago , IL 60601  
USA  
(312) 216-1626  
Fax: (773)661-2555  
Email:Jshimota@mavllp.Com

Aaron Charles Taggart  
ATTORNEY TO BE NOTICED  
Mavrakakis Law Group LLP  
180 N. Lasalle Suite 2215  
Chicago , IL 60601  
USA  
(312) 216-1627  
Email:Ataggart@mavllp.Com

Adam Robert Brausa  
[Term: 06/02/2014]  
Mavrakakis Law Group LLP  
180 North Lasalle Street Suite 2215  
Chicago , IL 60601  
USA  
(312) 216-1626  
Email:Abrausa@mavllp.Com

Howard E Levin  
ATTORNEY TO BE NOTICED  
Mavrakakis Law Group LLP

180 N. Lasalle Suite 2215  
Chicago , IL 60601  
USA  
312-216-1620  
Fax: (630) 881-7438  
Email:Hlevin@mavllp.Com

Bmw of North America, Llc  
Defendant

Andrew Neal Stein  
PRO HAC VICE;ATTORNEY TO BE NOTICED  
Dla Piper Llp (us)  
500 Eighth Street, Nw Suite 5026  
Washington , DC 20004  
USA  
(202) 799-4782  
Email:Andrew.Stein@dlapiper.Com

Joseph P. Lavelle  
PRO HAC VICE;ATTORNEY TO BE NOTICED  
DLA Piper LLP  
500 Eighth Street, Nw Suite 5034  
Washington , DC 20004  
USA  
(202) 799 4780  
Fax: 202 799 5022  
Email:Joe.Lavelle@dlapiper.Com

Steven John Reynolds  
ATTORNEY TO BE NOTICED  
DLA Piper US LLP IL  
203 North Lasalle Street 20th Floor  
Chicago , IL 60601  
USA  
312 368 3467  
Email:Steven.Reynolds@dlapiper.Com

Bmw Manufacturing Co., Llc  
Defendant

Andrew Neal Stein  
PRO HAC VICE;ATTORNEY TO BE NOTICED  
Dla Piper Llp (us)  
500 Eighth Street, Nw Suite 5026  
Washington , DC 20004  
USA  
(202) 799-4782  
Email:Andrew.Stein@dlapiper.Com

Joseph P. Lavelle  
PRO HAC VICE;ATTORNEY TO BE NOTICED  
DLA Piper LLP  
500 Eighth Street, Nw Suite 5034  
Washington , DC 20004  
USA  
(202) 799 4780  
Fax: 202 799 5022  
Email:Joe.Lavelle@dlapiper.Com

Steven John Reynolds  
ATTORNEY TO BE NOTICED  
DLA Piper US LLP IL  
203 North Lasalle Street 20th Floor  
Chicago , IL 60601

Bmw of North America, Llc  
Counter Claimant

USA  
312 368 3467  
Email:Steven.Reynolds@dlapiper.Com

Joseph P. Lavelle  
PRO HAC VICE;ATTORNEY TO BE NOTICED  
DLA Piper LLP  
500 Eighth Street, Nw Suite 5034  
Washington , DC 20004  
USA  
(202) 799 4780  
Fax: 202 799 5022  
Email:Joe.Lavelle@dlapiper.Com

Steven John Reynolds  
ATTORNEY TO BE NOTICED  
DLA Piper US LLP IL  
203 North Lasalle Street 20th Floor  
Chicago , IL 60601  
USA  
312 368 3467  
Email:Steven.Reynolds@dlapiper.Com

Velocity Patent Llc  
Counter Defendant

James A Shimota  
LEAD ATTORNEY;ATTORNEY TO BE NOTICED  
Mavrakakis Law Group LLP  
180 N. Lasalle Suite 2215  
Chicago , IL 60601  
USA  
(312) 216-1626  
Fax: (773)661-2555  
Email:Jshimota@mavllp.Com

Aaron Charles Taggart  
ATTORNEY TO BE NOTICED  
Mavrakakis Law Group LLP  
180 N. Lasalle Suite 2215  
Chicago , IL 60601  
USA  
(312) 216-1627  
Email:Ataggart@mavllp.Com

Adam Robert Brausa  
[Term: 06/02/2014]  
Mavrakakis Law Group LLP  
180 North Lasalle Street Suite 2215  
Chicago , IL 60601  
USA  
(312) 216-1626  
Email:Abrausa@mavllp.Com

Howard E Levin  
ATTORNEY TO BE NOTICED  
Mavrakakis Law Group LLP  
180 N. Lasalle Suite 2215  
Chicago , IL 60601  
USA  
312-216-1620  
Fax: (630) 881-7438



Email:Hlevin@mavllp.Com

Bmw Manufacturing Co., Llc  
Counter Claimant

Joseph P. Lavelle  
PRO HAC VICE;ATTORNEY TO BE NOTICED  
DLA Piper LLP  
500 Eighth Street, Nw Suite 5034  
Washington , DC 20004  
USA  
(202) 799 4780  
Fax: 202 799 5022  
Email:Joe.Lavelle@dlapiper.Com

Steven John Reynolds  
ATTORNEY TO BE NOTICED  
DLA Piper US LLP IL  
203 North LaSalle Street 20th Floor  
Chicago , IL 60601  
USA  
312 368 3467  
Email:Steven.Reynolds@dlapiper.Com

Velocity Patent Llc  
Counter Defendant

James A Shimota  
LEAD ATTORNEY;ATTORNEY TO BE NOTICED  
Mavrakakis Law Group LLP  
180 N. LaSalle Suite 2215  
Chicago , IL 60601  
USA  
(312) 216-1626  
Fax: (773)661-2555  
Email:Jshimota@mavllp.Com

Aaron Charles Taggart  
ATTORNEY TO BE NOTICED  
Mavrakakis Law Group LLP  
180 N. LaSalle Suite 2215  
Chicago , IL 60601  
USA  
(312) 216-1627  
Email:Ataggart@mavllp.Com

Adam Robert Brausa  
[Term: 06/02/2014]  
Mavrakakis Law Group LLP  
180 North LaSalle Street Suite 2215  
Chicago , IL 60601  
USA  
(312) 216-1626  
Email:Abrausa@mavllp.Com

Howard E Levin  
ATTORNEY TO BE NOTICED  
Mavrakakis Law Group LLP  
180 N. LaSalle Suite 2215  
Chicago , IL 60601  
USA  
312-216-1620  
Fax: (630) 881-7438  
Email:Hlevin@mavllp.Com

Date	#	Proceeding Text	Source
11/21/2013	1	COMPLAINT filed by Velocity Patent LLC; Jury Demand. Filing fee \$ 400, receipt number 0752-8957703. (Attachments: # 1 Exhibit Ex. A)(Shimota, James) (Entered: 11/21/2013)	
11/21/2013	2	CIVIL Cover Sheet (Shimota, James) (Entered: 11/21/2013)	
11/21/2013	3	ATTORNEY Appearance for Plaintiff Velocity Patent LLC by James A Shimota (Shimota, James) (Entered: 11/21/2013)	
11/21/2013		CASE ASSIGNED Designated as Magistrate Judge the Honorable Arlander Keys. (Entered in error) (nsf, ) Modified on 11/21/2013 (lw, ). (Entered: 11/21/2013)	
11/21/2013		CASE ASSIGNED to the Honorable Harry D. Leinenweber. Designated as Magistrate Judge the Honorable Arlander Keys. (nsf, ) (Entered: 11/21/2013)	
11/21/2013	4	ATTORNEY Appearance for Plaintiff Velocity Patent LLC by Howard E Levin (Levin, Howard) (Entered: 11/21/2013)	
11/21/2013		SUMMONS Issued as to Defendants BMW Manufacturing Co., LLC, BMW of North America, LLC (pg, ) (Entered: 11/21/2013)	
11/21/2013	5	ATTORNEY Appearance for Plaintiff Velocity Patent LLC by Adam Robert Brausa (Brausa, Adam) (Entered: 11/21/2013)	
11/21/2013	6	NOTIFICATION of Affiliates pursuant to Local Rule 3.2 by Velocity Patent LLC (Shimota, James) (Entered: 11/21/2013)	
11/21/2013	7	Rule 3.4 Notice of Claims Involving Patents by Velocity Patent LLC (Shimota, James) (Entered: 11/21/2013)	
11/27/2013	8	Entered in error. (mgh, ). (Entered: 11/27/2013)	
12/02/2013	9	NOTICE of Correction (mgh, ) (Entered: 12/02/2013)	
12/02/2013	10	SUMMONS Returned Executed by Velocity Patent LLC as to BMW of North America, LLC on 11/22/2013, answer due 12/13/2013. (Shimota, James) (Entered: 12/02/2013)	
12/02/2013	11	MAILED patent report to Patent Trademark Office, Alexandria VA (mgh, ) (Entered: 12/02/2013)	
12/04/2013	12	ATTORNEY Appearance for Plaintiff Velocity Patent LLC by Aaron Charles Taggart (Taggart, Aaron) (Entered: 12/04/2013)	
12/09/2013	13	ATTORNEY Appearance for Defendants BMW Manufacturing Co., LLC, BMW of North America, LLC by Steven John Reynolds (Reynolds, Steven) (Entered: 12/09/2013)	
12/09/2013	14	NOTIFICATION of Affiliates pursuant to Local Rule 3.2 by BMW Manufacturing Co., LLC, BMW of North America, LLC (Reynolds, Steven) (Entered: 12/09/2013)	
12/09/2013	15	MOTION by Defendants BMW Manufacturing Co., LLC, BMW of North America, LLC for extension of time to file answer regarding complaint 1 Unopposed Motion For Extension of Time to Answer or Otherwise Plead to Complaint (Reynolds, Steven) (Entered: 12/09/2013)	
12/09/2013	16	NOTICE of Motion by Steven John Reynolds for presentment of motion for extension of time to file answer, motion for relief 15 before Honorable Harry D. Leinenweber on 12/12/2013 at 09:30 AM. (Reynolds, Steven) (Entered: 12/09/2013)	
12/12/2013	18	MINUTE entry before the Honorable Harry D. Leinenweber:The Unopposed Motion for extension of time to 1/27/2014 in which to answer or otherwise plead 15 is granted.Mailed notice (wp, ) (Entered: 12/18/2013)	
12/17/2013	17	SUMMONS Returned Executed by Velocity Patent LLC as to BMW Manufacturing Co., LLC on 11/22/2013, answer due 12/13/2013.	

- (Shimota, James) (Entered: 12/17/2013)
- 01/23/2014 19 BMW of North America, LLC & BMW Manufacturing Co., LLC's Response to Velocity's Motion to Reassign by BMW Manufacturing Co., LLC, BMW of North America, LLC (Reynolds, Steven) (Entered: 01/23/2014)
- 01/27/2014 20 MOTION for Leave to Appear Pro Hac Vice Filing fee \$ 50, receipt number 0752-9139260. (Lavelle, Joseph) (Entered: 01/27/2014)
- 01/27/2014 21 ANSWER to Complaint with Jury Demand , COUNTERCLAIM filed by BMW of North America, LLC against Velocity Patent LLC . by BMW of North America, LLC(Reynolds, Steven) (Entered: 01/27/2014)
- 01/27/2014 22 ANSWER to Complaint with Jury Demand , COUNTERCLAIM filed by BMW Manufacturing Co., LLC against Velocity Patent LLC . by BMW Manufacturing Co., LLC(Reynolds, Steven) (Entered: 01/27/2014)
- 01/28/2014 23 MOTION for Leave to Appear Pro Hac Vice Filing fee \$ 50, receipt number 0752-9142672. (Stein, Andrew) (Entered: 01/28/2014)
- 02/04/2014 24 NOTICE by James A Shimota of Change of Address (Shimota, James) (Entered: 02/04/2014)
- 02/04/2014 25 NOTICE by Howard E Levin of Change of Address (Levin, Howard) (Entered: 02/04/2014)
- 02/04/2014 26 NOTICE by Aaron Charles Taggart of Change of Address (Taggart, Aaron) (Entered: 02/04/2014)
- 02/04/2014 27 NOTICE by Adam Robert Brausa of Change of Address (Brausa, Adam) (Entered: 02/04/2014)
- 02/18/2014 28 ANSWER to counterclaim by Velocity Patent LLC(Shimota, James) (Entered: 02/18/2014)
- 02/18/2014 29 ANSWER to counterclaim by Velocity Patent LLC(Shimota, James) (Entered: 02/18/2014)
- 04/03/2014 30 REPORT of Rule 26(f) Planning Meeting (Attachments: # 1 Exhibit 1) (Shimota, James) (Entered: 04/03/2014)
- 04/24/2014 31 EXECUTIVE COMMITTEE ORDER: Case reassigned to the Honorable John W. Darrah for all further proceedings, in accordance with the provisions of Local Rule 40.4 of this Court. Signed by Executive Committee on 4/24/2014. (For further details see order). (mgh, ) (Entered: 04/25/2014)
- 04/24/2014 32 ORDER Signed by the Honorable John W. Darrah on 4/24/2014: Ruling on motion hearing held. Pro hac vice motions are granted [20, 23]. Status hearing set for 5/7/14 at 9:30 a.m.Mailed notice (mgh, ) (Entered: 04/28/2014)
- 05/07/2014 33 MINUTE entry before the Honorable John W. Darrah: Status hearing held and continued to 8/19/14 at 9:30 a.m. Mailed notice(maf) (Entered: 05/07/2014)
- 05/30/2014 34 MOTION by counsel for Plaintiff Velocity Patent LLC to withdraw as attorney Adam R. Brausa (Shimota, James) (Entered: 05/30/2014)
- 05/30/2014 35 NOTICE of Motion by James A Shimota for presentment of motion to withdraw as attorney 34 before Honorable John W. Darrah on 6/5/2014 at 09:30 AM. (Shimota, James) (Entered: 05/30/2014)
- 06/02/2014 36 MINUTE entry before the Honorable John W. Darrah: Plaintiff's Motion to Withdraw Counsel Adam R. Brausa 34 is granted. No appearances necessary on June 5, 2014. All other dates remain as scheduled. Mailed notice(maf) (Entered: 06/02/2014)
- 07/17/2014 37 BMW Defendants' Notice Of Joinder To Motion To Stay (Docket No. 85 in 13-cv-8418) - by BMW Manufacturing Co., LLC, BMW of North America, LLC (Attachments: # 1 Table of Contents of Exhibits, # 2 Exhibit A, # 3

- Exhibit B, # 4 Exhibit C, # 5 Exhibit D)(Reynolds, Steven) (Entered: 07/17/2014)
- 08/04/2014 38 STIPULATION of Dismissal Joint Motion to Dismiss with Prejudice (Shimota, James) (Entered: 08/04/2014)
- 08/12/2014 39 ORDER Signed by the Honorable John W. Darrah on 8/12/2014: Enter order of dismissal. Civil case closed. Mailed notice (mgh, ) (Entered: 08/13/2014)
- 08/12/2014 40 ORDER of Dismissal Signed by the Honorable John W. Darrah on 8/12/2014. Mailed notice (mgh, ) (Entered: 08/13/2014)
- 10/21/2014 41 MAILED Patent report with certified copy of order dated 8/12/2014 to Patent Trademark Office, Alexandria VA. (mgh, ) (Entered: 10/21/2014)

---

Copyright © 2015 LexisNexis CourtLink, Inc. All rights reserved.  
\*\*\* THIS DATA IS FOR INFORMATIONAL PURPOSES ONLY \*\*\*

---

**US District Court Civil Docket**

U.S. District - Illinois Northern  
(Chicago)

**1:13cv8418**

**Velocity Patent Llc v. Audi of America, Inc. et al**

**This case was retrieved from the court on Monday, March 23, 2015**

---

<b>Date Filed:</b> 11/21/2013	<b>Class Code:</b> OPEN
<b>Assigned To:</b> Honorable John W. Darrah	<b>Closed:</b>
<b>Referred To:</b> Honorable Michael T. Mason	<b>Statute:</b> 35:271
<b>Nature of suit:</b> Patent (830)	<b>Jury Demand:</b> Both
<b>Cause:</b> Patent Infringement	<b>Demand Amount:</b> \$0
<b>Lead Docket:</b> None	<b>NOS Description:</b> Patent
<b>Other Docket:</b> 1:13cv08413	
<b>Jurisdiction:</b> Federal Question	

**Litigants**

**Attorneys**

Velocity Patent Llc  
Plaintiff

Aaron Charles Taggart  
ATTORNEY TO BE NOTICED  
Mavrakakis Law Group LLP  
180 N. Lasalle Suite 2215  
Chicago , IL 60601  
USA  
(312) 216-1627  
Email:Ataggart@mavllp.Com

Adam Robert Brausa  
[Term: 06/02/2014]  
Mavrakakis Law Group LLP  
180 North Lasalle Street Suite 2215  
Chicago , IL 60601  
USA  
(312) 216-1626  
Email:Abrausa@mavllp.Com

Howard E Levin  
ATTORNEY TO BE NOTICED  
Mavrakakis Law Group LLP  
180 N. Lasalle Suite 2215  
Chicago , IL 60601  
USA  
312-216-1620  
Fax: (630) 881-7438  
Email:Hlevin@mavllp.Com

James A Shimota  
ATTORNEY TO BE NOTICED  
Mavrakakis Law Group LLP

180 N. Lasalle Suite 2215  
Chicago , IL 60601  
USA  
(312) 216-1626  
Fax: (773)661-2555  
Email:Jshimota@mavllp.Com

Audi of America, Inc.  
Defendant

Georg Reitboeck  
LEAD ATTORNEY;PRO HAC VICE;ATTORNEY TO BE  
NOTICED  
Kenyon & Kenyon  
One Broadway  
New York , NY 10004  
USA  
(212) 908-6439  
Email:Greitboeck@kenyon.Com

Jeffrey Mark Drake  
ATTORNEY TO BE NOTICED  
Miller, Canfield, Paddock and Stone  
225 W. Washington Suite 2600  
Chicago , IL 60606  
USA  
3124604234  
Fax: 3124604201  
Email:Drakej@millercanfield.Com

Michael J Lennon  
ATTORNEY TO BE NOTICED  
Kenyon & Kenyon  
One Broadway  
New York , NY 10004  
USA  
(212) 425-7200  
Email:MLennon@kenyon.Com

Ryan Christopher Williams  
ATTORNEY TO BE NOTICED  
Miller Canfield Paddock and Stone PLC  
225 West Washington Street Suite 2600  
Chicago , IL 60606  
USA  
312 460 4228  
Fax: 312-460-4288  
Email:Williamsr@millercanfield.Com

Susan Ann Smith  
PRO HAC VICE;ATTORNEY TO BE NOTICED  
Kenyon & Kenyon LLP  
1500 K Street, N.W., Suite 700  
Washington , DC 20005  
USA  
(202) 220-4321  
Email:Ssmith@kenyon.Com

Audi of America, Llc  
[Term: 01/30/2014]  
Defendant

Jeffrey Mark Drake  
ATTORNEY TO BE NOTICED  
Miller, Canfield, Paddock and Stone  
225 W. Washington Suite 2600

Chicago , IL 60606  
USA  
3124604234  
Fax: 3124604201  
Email:Drakej@millercanfield.Com

Michael J Lennon  
ATTORNEY TO BE NOTICED  
Kenyon & Kenyon  
One Broadway  
New York , NY 10004  
USA  
(212) 425-7200  
Email:MLennon@kenyon.Com

Ryan Christopher Williams  
ATTORNEY TO BE NOTICED  
Miller Canfield Paddock and Stone PLC  
225 West Washington Street Suite 2600  
Chicago , IL 60606  
USA  
312 460 4228  
Fax: 312-460-4288  
Email:Williamsr@millercanfield.Com

Susan Ann Smith  
PRO HAC VICE;ATTORNEY TO BE NOTICED  
Kenyon & Kenyon LLP  
1500 K Street, N.W., Suite 700  
Washington , DC 20005  
USA  
(202) 220-4321  
Email:Ssmith@kenyon.Com

Audi of America, Inc.  
Counter Claimant

Georg Reitboeck  
LEAD ATTORNEY;ATTORNEY TO BE NOTICED  
Kenyon & Kenyon  
One Broadway  
New York , NY 10004  
USA  
(212) 908-6439  
Email:Greitboeck@kenyon.Com

Jeffrey Mark Drake  
ATTORNEY TO BE NOTICED  
Miller, Canfield, Paddock and Stone  
225 W. Washington Suite 2600  
Chicago , IL 60606  
USA  
3124604234  
Fax: 3124604201  
Email:Drakej@millercanfield.Com

Michael J Lennon  
ATTORNEY TO BE NOTICED  
Kenyon & Kenyon  
One Broadway  
New York , NY 10004  
USA  
(212) 425-7200

Email: Mlennon@kenyon.Com

Ryan Christopher Williams  
ATTORNEY TO BE NOTICED  
Miller Canfield Paddock and Stone PLC  
225 West Washington Street Suite 2600  
Chicago , IL 60606  
USA  
312 460 4228  
Fax: 312-460-4288  
Email: Williamsr@millercanfield.Com

Susan Ann Smith  
ATTORNEY TO BE NOTICED  
Kenyon & Kenyon LLP  
1500 K Street, N.W., Suite 700  
Washington , DC 20005  
USA  
(202) 220-4321  
Email: Ssmith@kenyon.Com

Velocity Patent Llc  
Counter Defendant

Aaron Charles Taggart  
ATTORNEY TO BE NOTICED  
Mavrakakis Law Group LLP  
180 N. LaSalle Suite 2215  
Chicago , IL 60601  
USA  
(312) 216-1627  
Email: Ataggart@mavllp.Com

Adam Robert Brausa  
[Term: 06/02/2014]  
Mavrakakis Law Group LLP  
180 North LaSalle Street Suite 2215  
Chicago , IL 60601  
USA  
(312) 216-1626  
Email: Abrausa@mavllp.Com

Howard E Levin  
ATTORNEY TO BE NOTICED  
Mavrakakis Law Group LLP  
180 N. LaSalle Suite 2215  
Chicago , IL 60601  
USA  
312-216-1620  
Fax: (630) 881-7438  
Email: Hlevin@mavllp.Com

James A Shimota  
ATTORNEY TO BE NOTICED  
Mavrakakis Law Group LLP  
180 N. LaSalle Suite 2215  
Chicago , IL 60601  
USA  
(312) 216-1626  
Fax: (773)661-2555  
Email: Jshimota@mavllp.Com



Date	#	Proceeding Text	Source
11/21/2013	1	COMPLAINT filed by Velocity Patent LLC; Jury Demand. Filing fee \$ 400, receipt number 0752-8957811. (Attachments: # 1 Exhibit Ex. A)(Shimota, James) (Entered: 11/21/2013)	
11/21/2013	2	CIVIL Cover Sheet (Shimota, James) (Entered: 11/21/2013)	
11/21/2013	3	ATTORNEY Appearance for Plaintiff Velocity Patent LLC by James A Shimota (Shimota, James) (Entered: 11/21/2013)	
11/21/2013		CASE ASSIGNED to the Honorable Joan B. Gottschall. Designated as Magistrate Judge the Honorable Geraldine Soat Brown. (nsf, ) (Entered: 11/21/2013)	
11/21/2013	4	ATTORNEY Appearance for Plaintiff Velocity Patent LLC by Howard E Levin (Levin, Howard) (Entered: 11/21/2013)	
11/21/2013	5	ATTORNEY Appearance for Plaintiff Velocity Patent LLC by Adam Robert Brausa (Brausa, Adam) (Entered: 11/21/2013)	
11/21/2013		SUMMONS Issued as to Defendants Audi of America, Inc., Audi of America, LLC (pg, ) (Entered: 11/21/2013)	
11/21/2013	6	NOTIFICATION of Affiliates pursuant to Local Rule 3.2 by Velocity Patent LLC (Shimota, James) (Entered: 11/21/2013)	
11/21/2013	7	Rule 3.4 Notice of Claims Involving Patents by Velocity Patent LLC (Shimota, James) (Entered: 11/21/2013)	
11/25/2013	8	ORDER: Status Hearing set for 01/17/14 at 9:30 AM. Plaintiff is directed to advise the defendants of the status hearing forthwith. Pursuant to LR 5.2 (f), a stapled and/or bound paper copy of all electronically filed documents, must be delivered to chambers (2356) within one business day. Noncompliance with LR 5.2(f) will result in the imposition of a \$200.00 fine payable to the Clerk of the Court, 219 South Dearborn Street, 20th Floor, Chicago, Illinois 60604. Parties are directed to discuss settlement of case, consent to proceed before the Magistrate Judge, and a proposed discovery plan. See Judge Gottschall's civil case management information regarding pretrial case management procedures at <a href="http://www.ilnd.uscourts.gov">http://www.ilnd.uscourts.gov</a> , Set/reset hearings. Mailed notice(vcf, ) (Entered: 11/26/2013)	
12/02/2013	9	SUMMONS Returned Executed by Velocity Patent LLC as to Audi of America, LLC on 11/22/2013, answer due 12/13/2013. (Shimota, James) (Entered: 12/02/2013)	
12/04/2013	10	ATTORNEY Appearance for Plaintiff Velocity Patent LLC by Aaron Charles Taggart (Taggart, Aaron) (Entered: 12/04/2013)	
12/06/2013	11	ATTORNEY Appearance for Defendants Audi of America, Inc., Audi of America, LLC by Jeffrey Mark Drake (Drake, Jeffrey) (Entered: 12/06/2013)	
12/06/2013	12	ATTORNEY Appearance for Defendants Audi of America, Inc., Audi of America, LLC by Ryan Christopher Williams (Williams, Ryan) (Entered: 12/06/2013)	
12/06/2013	13	PAYMENT by Audi of America, Inc., Audi of America, LLC of Pro Hac Fee \$ 50, receipt number 0752-8998643. (Lennon, Michael) (Entered: 12/06/2013)	
12/06/2013	14	MOTION for Leave to Appear Pro Hac Vice (Lennon, Michael) (Entered: 12/06/2013)	
12/06/2013	15	MOTION for Leave to Appear Pro Hac Vice Filing fee \$ 50, receipt number 0752-8998762. (Smith, Susan) (Entered: 12/06/2013)	
12/06/2013	16	MOTION by Defendants Audi of America, Inc., Audi of America, LLC for extension of time to file answer regarding complaint 1 UNOPPOSED	

- MOTION (Drake, Jeffrey) (Entered: 12/06/2013)
- 12/06/2013 17 NOTICE of Motion by Jeffrey Mark Drake for presentment of motion for extension of time to file answer, motion for relief 16 before Honorable Joan B. Gottschall on 12/18/2013 at 09:30 AM. (Drake, Jeffrey) (Entered: 12/06/2013)
- 12/09/2013 18 MINUTE entry before the Honorable Joan B. Gottschall:Attorney Michael J. Lennon's application to appear pro hac vice 14 on behalf of the defendants is granted. Attorney Susan A. Smith's application to appear pro hac vice 15 on behalf of the defendants is granted. Mailed notice (ef, ) (Entered: 12/09/2013)
- 12/16/2013 19 MINUTE entry before the Honorable Joan B. Gottschall: Defendants' motion for extension of time to file answer 16 is granted. Defendants to answer or otherwise plead by January 27, 2014. Motion hearing set for 12/18/2014 at 9:30 is stricken. Mailed notice (ef, ) (Entered: 12/16/2013)
- 12/18/2013 20 SUMMONS Returned Executed by Velocity Patent LLC as to Audi of America, Inc. on 11/26/2013, answer due 12/17/2013. (Shimota, James) (Entered: 12/18/2013)
- 01/09/2014 21 MINUTE entry before the Honorable Joan B. Gottschall: By the agreement of parties, status hearing set for 01/17/2014 is stricken and reset for 2/14/2014 at 09:30 a.m. Mailed notice (ef, ) (Entered: 01/09/2014)
- 01/27/2014 22 NOTIFICATION of Affiliates pursuant to Local Rule 3.2 by Audi of America, Inc., Audi of America, LLC (Drake, Jeffrey) (Entered: 01/27/2014)
- 01/27/2014 23 MOTION TO DISMISS FOR FAILURE TO STATE A CLAIM (Drake, Jeffrey) (Entered: 01/27/2014)
- 01/27/2014 24 MEMORANDUM by Audi of America, Inc., Audi of America, LLC in support of Motion to Dismiss for Failure to State a Claim 23 (Drake, Jeffrey) (Entered: 01/27/2014)
- 01/27/2014 25 NOTICE of Motion by Jeffrey Mark Drake for presentment of Motion to Dismiss for Failure to State a Claim 23 before Honorable Joan B. Gottschall on 1/31/2014 at 09:30 AM. (Drake, Jeffrey) (Entered: 01/27/2014)
- 01/30/2014 26 MINUTE entry before the Honorable Joan B. Gottschall: Plaintiff's Responses to Motion to Dismiss 23 due by 2/21/2014; replies due by 3/7/2014. Motion hearing set for 1/31/2014 is stricken. No appearance is required. Mailed notice (ef, ) (Entered: 01/30/2014)
- 01/30/2014 27 NOTICE of Voluntary Dismissal by Velocity Patent LLC (Shimota, James) (Entered: 01/30/2014)
- 01/30/2014 28 AMENDED complaint by Velocity Patent LLC against Audi of America, Inc. and terminating Audi of America, LLC (Attachments: # 1 Exhibit Ex. A) (Shimota, James) (Entered: 01/30/2014)
- 01/30/2014 29 First Amended Rule 3.4 Notice of Claims Involving Patents by Velocity Patent LLC (Shimota, James) (Entered: 01/30/2014)
- 02/04/2014 30 NOTICE by James A Shimota of Change of Address (Shimota, James) (Entered: 02/04/2014)
- 02/04/2014 31 NOTICE by Howard E Levin of Change of Address (Levin, Howard) (Entered: 02/04/2014)
- 02/04/2014 32 NOTICE by Aaron Charles Taggart of Change of Address (Taggart, Aaron) (Entered: 02/04/2014)
- 02/04/2014 33 NOTICE by Adam Robert Brausa of Change of Address (Brausa, Adam) (Entered: 02/04/2014)
- 02/07/2014 34 REPORT of Rule 26(f) Planning Meeting (Attachments: # 1 Exhibit 1) (Shimota, James) (Entered: 02/07/2014)
- 02/14/2014 35 MINUTE entry before the Honorable Joan B. Gottschall: Status hearing

- held. Defendant's motion to dismiss 23 is moot. Status hearing set for 5/16/2014 at 9:30 a.m. Mailed notice (ef, ) (Entered: 02/14/2014)
- 02/18/2014 36 Second MOTION TO DISMISS FOR FAILURE TO STATE A CLAIM (Williams, Ryan) (Entered: 02/18/2014)
- 02/18/2014 37 MEMORANDUM by Audi of America, Inc. in support of Motion to Dismiss for Failure to State a Claim 36 (Williams, Ryan) (Entered: 02/18/2014)
- 02/18/2014 38 NOTICE of Motion by Ryan Christopher Williams for presentment of Motion to Dismiss for Failure to State a Claim 36 before Honorable Joan B. Gottschall on 3/5/2014 at 11:00 AM. (Williams, Ryan) (Entered: 02/18/2014)
- 03/04/2014 39 MINUTE entry before the Honorable Joan B. Gottschall: Plaintiff's Responses to Motion to Dismiss for Failure to State a Claim 36 due by 3/19/2014; replies due by 4/2/2014. Motion hearing set for 3/5/2014 is stricken. No appearance is required. Mailed notice (ef, ) (Entered: 03/04/2014)
- 03/04/2014 40 MOTION by Defendant Audi of America, Inc. to amend/correct , MOTION by Defendant Audi of America, Inc. for protective order (Attachments: # 1 Exhibit 1 - Proposed Protective Order, # 2 Exhibit 2 - Redlined Protective Order, # 3 Exhibit 3 - Assignment, # 4 Exhibit 4 - Mavrakakis Bio, # 5 Exhibit 5 - Velocity Patents)(Williams, Ryan) (Entered: 03/04/2014)
- 03/04/2014 41 NOTICE of Motion by Ryan Christopher Williams for presentment of motion to amend/correct,, motion for protective order, 40 before Honorable Joan B. Gottschall on 3/12/2014 at 11:00 AM. (Williams, Ryan) (Entered: 03/04/2014)
- 03/11/2014 42 MINUTE entry before the Honorable Joan B. Gottschall: Plaintiff's Response to defendant's motion to amend protective order 40 due by 3/18/2014 ; replies due by 3/25/2014. Motion hearing set for 3/12/2014 is stricken. Mailed notice (ef, ) (Entered: 03/11/2014)
- 03/17/2014 43 MINUTE entry before the Honorable Joan B. Gottschall: On the court's own motion, Status hearing set for 5/16/2014 is reset for 5/30/2014 at 09:30 AM. Mailed notice (ef, ) (Entered: 03/17/2014)
- 03/18/2014 44 RESPONSE by Velocity Patent LLCin Opposition to MOTION by Defendant Audi of America, Inc. to amend/correct MOTION by Defendant Audi of America, Inc. for protective order 40 (Attachments: # 1 Exhibit A, # 2 Exhibit B)(Shimota, James) (Entered: 03/18/2014)
- 03/19/2014 45 RESPONSE by Velocity Patent LLCin Opposition to Second MOTION TO DISMISS FOR FAILURE TO STATE A CLAIM 36 (Shimota, James) (Entered: 03/19/2014)
- 03/25/2014 46 REPLY by Audi of America, Inc. to response in opposition to motion, 44 to Amend/Correct Protective Order (Williams, Ryan) (Entered: 03/25/2014)
- 04/02/2014 47 REPLY by Audi of America, Inc. to response in opposition to motion 45 to dismiss First Amended Complaint (Williams, Ryan) (Entered: 04/02/2014)
- 04/08/2014 48 NOTICE of Motion by James A Shimota for presentment of before Honorable Joan B. Gottschall on 4/11/2014 at 09:30 AM. (Shimota, James) (Entered: 04/08/2014)
- 04/08/2014 49 MOTION by Plaintiff Velocity Patent LLC to compel LOCAL PATENT RULE 2.1(b)(1) DISCLOSURES AND RESPONSES TO DISCOVERY (Attachments: # 1 Exhibit A, # 2 Exhibit B, # 3 Exhibit C, # 4 Exhibit D, # 5 Exhibit E, # 6 Exhibit F, # 7 Exhibit G)(Shimota, James) (Entered: 04/08/2014)
- 04/09/2014 50 MOTION by Defendant Audi of America, Inc. to transfer case to Eastern District of Michigan (Drake, Jeffrey) (Entered: 04/09/2014)
- 04/09/2014 51 MEMORANDUM by Audi of America, Inc. in support of motion to transfer case 50 (Attachments: # 1 Exhibit 1 - 16)(Drake, Jeffrey) (Entered: 04/09/2014)

- 04/09/2014) 04/09/2014 52 DECLARATION of Robert A. Arturi regarding memorandum in support of motion 51 , motion to transfer case 50 (Drake, Jeffrey) (Entered: 04/09/2014)
- 04/09/2014 53 NOTICE of Motion by Jeffrey Mark Drake for presentment of motion to transfer case 50 before Honorable Joan B. Gottschall on 4/16/2014 at 09:30 AM. (Drake, Jeffrey) (Entered: 04/09/2014)
- 04/10/2014 54 MOTION by Defendant Audi of America, Inc. to stay and limit discovery (Williams, Ryan) (Entered: 04/10/2014)
- 04/10/2014 55 MEMORANDUM by Audi of America, Inc. in support of motion to stay 54 and limit discovery (Attachments: # 1 3-4-14 Velocity RFPs to Audi, # 2 3-4-14 Velocity Rogs to Audi)(Williams, Ryan) (Entered: 04/10/2014)
- 04/10/2014 56 NOTICE of Motion by Ryan Christopher Williams for presentment of motion to stay 54 before Honorable Joan B. Gottschall on 4/16/2014 at 09:30 AM. (Williams, Ryan) (Entered: 04/10/2014)
- 04/11/2014 57 MINUTE entry before the Honorable Joan B. Gottschall: Motion hearing held. Responses to Plaintiff's Motion to Compel 49 , Motion to Transfer 50 , and Motion to Stay 54 due 5/9/2014. Replies due 5/23/2014. Motion hearings set for 4/16/2014 are stricken. Mailed notice (ef, ) (Entered: 04/11/2014)
- 04/24/2014 58 MOTION for Leave to Appear Pro Hac Vice Filing fee \$ 50, receipt number 0752-9419562. for Georg Reitboeck (Reitboeck, Georg) (Entered: 04/24/2014)
- 04/24/2014 59 EXECUTIVE COMMITTEE ORDER: Case reassigned to the Honorable John W. Darrah for all further proceedings pursuant to local rule 40.4. Signed by Executive Committee on 4/24/2014. (vcf, ) (Entered: 04/25/2014)
- 04/24/2014 62 ORDER: Ruling on motion hearing held. Pro hac vice motion is granted 58 . Defendant's motion to transfer 50 is entered and briefed as follows: response by 5/9/14, reply by 5/23/14. In court hearing/ruling is set for 8/19/14 at 9:30 a.m. Defendant's second motion to dismiss 36 , defendant's motion to amend the protective order 40 , and defendant's motion to stay and for limited discovery 54 are entered and continued to 5/7/14 at 9:30 a.m. Status hearing set for 5/7/14 at 9:30 a.m. Signed by the Honorable John W. Darrah on 4/24/2014. Mailed notice(vcf, ) (Entered: 04/28/2014)
- 04/28/2014 60 Pursuant to Local Rule 72.1, this case is hereby referred to the calendar of Honorable Michael T. Mason for the purpose of holding proceedings related to: discovery motions and discovery disputes, including plaintiff's motion to compel 49 . Any extension to the discovery deadline must be heard by Judge Darrah. Mailed notice. (maf) (Entered: 04/28/2014)
- 04/28/2014 61 MINUTE entry before the Honorable Michael T. Mason: This case has been referred to Magistrate Judge Mason. An initial status hearing is set for 05/13/14 at 9:00 a.m. in courtroom 2266. Counsel shall confer with each other and submit an Agreed Proposed Scheduling Order to the proposed order inbox at: Proposed\_Order\_Mason@ilnd.uscourts.gov by 05/08/14. The response and reply dates previously set 57 stand for plaintiff's motion to compel 49 . Pursuant to Local Rule 5.2(f), the parties are reminded to submit courtesy copies to chambers, room 2270, within one business day of filing. (rbf, ) (Entered: 04/28/2014)
- 04/29/2014 63 ATTORNEY Appearance for Defendant Audi of America, Inc. by Michael J Lennon (Lennon, Michael) (Entered: 04/29/2014)
- 04/29/2014 64 ATTORNEY Appearance for Defendant Audi of America, Inc. by Georg Reitboeck (Reitboeck, Georg) (Entered: 04/29/2014)
- 05/05/2014 65 ATTORNEY Appearance for Defendant Audi of America, Inc. by Susan Ann

- Smith (Smith, Susan) (Entered: 05/05/2014)
- 05/07/2014 66 ORDER: Status hearing held. The Court being advised from the parties that the following motions are fully briefed: defendant's second motion to dismiss 36 and defendant's motion to amend the protective order 40 , a status hearing/ruling is set for 8/19/14 at 9:30 a.m. Defendant's motion to stay and for limited discovery 54 is entered and continued to 8/19/14 at 9:30 a.m. Signed by the Honorable John W. Darrah on 5/7/2014. Mailed notice(vcf, ) (Entered: 05/08/2014)
- 05/08/2014 67 STATUS Report by Velocity Patent LLC (Shimota, James) (Entered: 05/08/2014)
- 05/08/2014 68 REPORT of Rule 26(f) Planning Meeting (Attachments: # 1 Exhibit 1) (Shimota, James) (Entered: 05/08/2014)
- 05/09/2014 69 RESPONSE by Velocity Patent LLCin Opposition to MOTION by Defendant Audi of America, Inc. to transfer case to Eastern District of Michigan 50 (Attachments: # 1 Exhibit 1, # 2 Exhibit 2, # 3 Exhibit 3, # 4 Exhibit 4, # 5 Exhibit 5, # 6 Exhibit 6, # 7 Exhibit 7, # 8 Exhibit 8, # 9 Exhibit 9, # 10 Exhibit 10, # 11 Exhibit 11, # 12 Exhibit 12, # 13 Exhibit 13, # 14 Exhibit 14, # 15 Exhibit 15)(Shimota, James) (Entered: 05/09/2014)
- 05/09/2014 70 RESPONSE by Audi of America, Inc.in Opposition to MOTION by Plaintiff Velocity Patent LLC to compel LOCAL PATENT RULE 2.1(b)(1) DISCLOSURES AND RESPONSES TO DISCOVERY 49 (Attachments: # 1 Exhibit 1, # 2 Exhibit 2, # 3 Exhibit 3, # 4 Exhibit 4)(Drake, Jeffrey) (Entered: 05/09/2014)
- 05/13/2014 71 MINUTE entry before the Honorable Michael T. Mason:Magistrate Judge Status hearing held on 5/13/14. The Court will rule by mail on plaintiff's motion to compel 49 and set a future status hearing at that time, if necessary. (rbf, ) (Entered: 05/13/2014)
- 05/22/2014 72 REPLY by Velocity Patent LLC to response in opposition to motion, 70 (Attachments: # 1 Exhibit 1, # 2 Exhibit 2, Part A, # 3 Exhibit 2, Part B, # 4 Exhibit 3, Part A, # 5 Exhibit 3, Part B)(Shimota, James) (Entered: 05/22/2014)
- 05/23/2014 73 REPLY by Audi of America, Inc. to response in opposition to motion, 69 , MOTION by Defendant Audi of America, Inc. to transfer case to Eastern District of Michigan 50 (Attachments: # 1 Exhibit VW Credit Website, # 2 Exhibit Audi Initial Invalidity Contentions, # 3 Exhibit Rogers PeopleSmart Search, # 4 Exhibit Jones PeopleSmart Search)(Williams, Ryan) (Entered: 05/23/2014)
- 05/30/2014 74 MOTION by counsel for Plaintiff Velocity Patent LLC to withdraw as attorney Adam R. Brausa (Shimota, James) (Entered: 05/30/2014)
- 05/30/2014 75 NOTICE of Motion by James A Shimota for presentment of motion to withdraw as attorney 74 before Honorable John W. Darrah on 6/5/2014 at 09:30 AM. (Shimota, James) (Entered: 05/30/2014)
- 06/02/2014 76 MINUTE entry before the Honorable John W. Darrah: Plaintiff's Motion to Withdraw Counsel Adam R. Brausa 74 is granted. No appearances necessary on June 5, 2014. All other dates remain as scheduled. Mailed notice(maf) (Entered: 06/02/2014)
- 06/05/2014 77 MOTION by Defendant Audi of America, Inc. to strike reply to response to motion 72 or, In the Alternative, For Leave to File a Sur-Reply Brief (Attachments: # 1 Exhibit A)(Drake, Jeffrey) (Entered: 06/05/2014)
- 06/05/2014 78 NOTICE of Motion by Jeffrey Mark Drake for presentment of motion to strike, motion for relief 77 before Honorable Michael T. Mason on 6/10/2014 at 09:00 AM. (Drake, Jeffrey) (Entered: 06/05/2014)
- 06/05/2014 79 MINUTE entry before the Honorable Michael T. Mason: Defendant's motion to strike plaintiff's reply or for leave to file a sur-reply 77 is granted as

- follows. Defendant's sur-reply, attached as Exhibit A to its motion, will be considered by the Court. Plaintiff's reply stands. The 06/10/14 notice of motion is stricken; the parties need not appear. (rbf, ) (Entered: 06/05/2014)
- 06/06/2014 80 MOTION by Plaintiff Velocity Patent LLC to compel L.P.R. 2.4(a) Disclosures (Attachments: # 1 Exhibit 1, # 2 Exhibit 2, # 3 Exhibit 3, # 4 Exhibit 4, # 5 Exhibit 5, # 6 Exhibit 6, # 7 Exhibit 7, # 8 Exhibit 8, # 9 Exhibit 9)(Shimota, James) (Entered: 06/06/2014)
- 06/06/2014 81 NOTICE of Motion by James A Shimota for presentment of motion to compel, 80 before Honorable Michael T. Mason on 6/11/2014 at 09:00 AM. (Shimota, James) (Entered: 06/06/2014)
- 06/09/2014 82 MINUTE entry before the Honorable Michael T. Mason:Defendant is directed to respond to plaintiff's motion to compel 80 by 06/23/14. Plaintiff shall reply by 06/30/14. The 06/11/14 notice of motion is stricken; the parties need not appear. (rbf, ) (Entered: 06/09/2014)
- 06/23/2014 83 MEMORANDUM by Audi of America, Inc. in Opposition to motion to compel, 80 (Williams, Ryan) (Entered: 06/23/2014)
- 06/30/2014 84 REPLY by Velocity Patent LLC to memorandum in opposition to motion 83 (Shimota, James) (Entered: 06/30/2014)
- 07/08/2014 85 MOTION by Defendant Audi of America, Inc. to stay Pending Re-Examination (Williams, Ryan) (Entered: 07/08/2014)
- 07/08/2014 86 MEMORANDUM by Audi of America, Inc. in support of motion to stay 85 Pending Re-Examination (Attachments: # 1 Exhibit 5-22-14 Request for Re-Examination, # 2 Exhibit 6-27-14 Re-Examination Order, # 3 Exhibit USPTO Re-Examination Data)(Williams, Ryan) (Entered: 07/08/2014)
- 07/08/2014 87 NOTICE of Motion by Ryan Christopher Williams for presentment of motion to stay 85 before Honorable John W. Darrah on 7/15/2014 at 09:30 AM. (Williams, Ryan) (Entered: 07/08/2014)
- 07/10/2014 88 ORDER: Plaintiff's Motion to Stay the Proceedings Pending Reexamination of the Patent-In-Suit 85 entered and briefed as follows: response by 7/29/14, reply by 8/5/14. No appearances necessary on July 15, 2014. All other dates remain as scheduled. Signed by the Honorable John W. Darrah on 7/10/2014. Mailed notice(vcf, ) (Entered: 07/11/2014)
- 07/11/2014 89 NOTICE of Motion by Jeffrey Mark Drake for presentment of motion to amend/correct, motion for protective order,, 40 before Honorable Michael T. Mason on 7/16/2014 at 09:00 AM. (Drake, Jeffrey) (Entered: 07/11/2014)
- 07/11/2014 90 MINUTE entry before the Honorable Michael T. Mason: For the reasons set forth in the accompanying Order, plaintiff's motion to compel LPR 2.1(b) (1) disclosures and responses to discovery 49 is granted in part and denied in part. By 08/01/14, defendant shall complete the required discovery requests. By 07/18/14 defendant shall identify any third parties who have possession, custody, or control of responsive documents or information. Plaintiff's motion to compel LPR 2.4(a) disclosures 80 is stayed. Defendant is directed to investigate and produce any additional, relevant documents by 07/25/14. If necessary, the parties are directed to meet and confer pursuant to LR 37.2 by 08/04/14 before filing any additional discovery motions. (rbf, ) (Entered: 07/11/2014)
- 07/11/2014 91 ORDER Signed by the Honorable Michael T. Mason on 7/11/2014.(rbf, ) (Entered: 07/11/2014)
- 07/15/2014 92 MINUTE entry before the Honorable Michael T. Mason:The 7/16/14 motion hearing on defendant's motion to amend the protective order is stricken as that motion is currently pending before the District Court 66 . No appearance is necessary on 7/16/14. (rbf, ) (Entered: 07/15/2014)

- 07/15/2014 93 Notice of Supplemental Authority by Audi of America, Inc. in Support of Motion to Stay Pending Reexamination (DE #85) (Attachments: # 1 Exhibit 1)(Williams, Ryan) (Entered: 07/15/2014)
- 07/17/2014 94 MOTION by Defendant Audi of America, Inc. to stay regarding order on motion to compel, text entry,,,,,, 90 , order 91 (Williams, Ryan) (Entered: 07/17/2014)
- 07/17/2014 95 NOTICE of Motion by Ryan Christopher Williams for presentment of motion to stay, motion for relief,, 94 before Honorable Michael T. Mason on 7/29/2014 at 09:00 AM. (Williams, Ryan) (Entered: 07/17/2014)
- 07/18/2014 96 MINUTE entry before the Honorable Michael T. Mason: The Court has reviewed defendant's motion to stay the deadlines in the 7/11/14 order 94 , in which defendant reports that it intends to file objections to that order before the District Court. As a result, and over plaintiff's objection, the motion is granted. The resources of the parties and the Court are best served with a stay of only those deadlines set in the 7/11/14 order. Defendant is advised, however, that following the ruling on its objections, it will be required to expeditiously provide any information and documents permitted by the District Court. The 7/29/14 motion hearing is stricken; no appearance is necessary on that date. (rbf, ) (Entered: 07/18/2014)
- 07/25/2014 97 NOTICE of Motion by James A Shimota for presentment of before Honorable John W. Darrah on 8/13/2014 at 09:30 AM. (Shimota, James) (Entered: 07/25/2014)
- 07/25/2014 98 MOTION by Plaintiff Velocity Patent LLC for extension of time to file response/reply as to order on motion to stay,, set motion and R&R deadlines/hearings, order on motion for relief,,,, 88 UNOPPOSED MOTION FOR EXTENSION OF TIME TO FILE RESPONSE TO DEFENDANT'S MOTION TO STAY PENDING REEXAMINATION (Shimota, James) (Entered: 07/25/2014)
- 07/25/2014 99 MOTION by Plaintiff Velocity Patent LLC for discovery OBJECTION TO ORDER REGARDING PLAINTIFF'S MOTION TO COMPEL LPR 2.1(B)(1) DISCLOSURES AND RESPONSES TO DISCOVERY AND PLAINTIFF'S MOTION TO COMPEL LPR 2.4(A) DISCLOSURES (Shimota, James) (Entered: 07/25/2014)
- 07/25/2014 100 NOTICE of Motion by James A Shimota for presentment of motion for discovery, 99 before Honorable John W. Darrah on 8/13/2014 at 09:30 AM. (Shimota, James) (Entered: 07/25/2014)
- 07/28/2014 101 OBJECTIONS by Audi of America, Inc. to order on motion to compel, text entry,,,,,, 90 , order 91 (Attachments: # 1 Exhibit Summary of 2013 AIPLA Report of the Economic Survey, # 2 Exhibit Lex Machina Damages Report)(Williams, Ryan) (Entered: 07/28/2014)
- 07/28/2014 102 NOTICE of Motion by Ryan Christopher Williams for presentment of before Honorable John W. Darrah on 8/13/2014 at 09:30 AM. (Williams, Ryan) (Entered: 07/28/2014)
- 08/05/2014 103 MEMORANDUM by Velocity Patent LLC in Opposition to motion to stay 85 (Attachments: # 1 Exhibit 1)(Shimota, James) (Entered: 08/05/2014)
- 08/12/2014 104 REPLY by Audi of America, Inc. to MOTION by Defendant Audi of America, Inc. to stay Pending Re-Examination 85 (Attachments: # 1 Exhibit August 4, 2014 Petition)(Williams, Ryan) (Entered: 08/12/2014)
- 08/13/2014 105 ORDER: In court hearing held. Plaintiff's motions [98,99] are entered and continued to 8/19/2014 at 9:30 a.m. Signed by the Honorable John W. Darrah on 8/13/2014. Mailed notice(vcf, ) (Entered: 08/18/2014)
- 08/19/2014 107 MEMORANDUM Opinion and Order Signed by the Honorable John W. Darrah on 8/19/2014. Mailed notice (tg, ) (Entered: 08/20/2014)
- 08/20/2014 106 ORDER: Status hearing and ruling on motion hearing held. For the reasons

- stated in the attached memorandum opinion and order, Audi's Motion to Dismiss for Failure to State a Claim 36 is denied. In the interest of justice and fairness, as well as the sake of convenience, Audi's Motion to Transfer Venue 50 is denied. This case will remain in the United States District Court for the Northern District of Illinois. Enter Memorandum Opinion and Order. Simultaneous briefs re: objections to the Magistrate's orders 99 to be filed by 9/3/14. Status hearing/ruling is set for 11/6/14 at 9:30 a.m. Plaintiff's unopposed motion for an extension of time to file a response to defendant's motion to stay pending reexamination is granted 98 . Response to be filed by 9/3/14. Status hearing/ruling is set for 11/6/14 at 9:30 a.m. re: defendant's motion to stay 85 . In court hearing/rescheduling the remainder of the case is set for 9/16/14 at 9:30 a.m. Mailed notice (tg, ) (Entered: 08/20/2014)
- 09/02/2014 108 ANSWER to amended complaint , COUNTERCLAIM filed by Audi of America, Inc. against Velocity Patent LLC . by Audi of America, Inc. (Attachments: # 1 Exhibit 1, # 2 Exhibit 2, # 3 Exhibit 3, # 4 Exhibit 4) (Drake, Jeffrey) (Entered: 09/02/2014)
- 09/03/2014 109 RESPONSE by Velocity Patent LLC to MOTION by Plaintiff Velocity Patent LLC for discovery OBJECTION TO ORDER REGARDING PLAINTIFF'S MOTION TO COMPEL LPR 2.1(B)(1) DISCLOSURES AND RESPONSES TO DISCOVERY AND PLAINTIFF'S MOTION TO COMPEL LPR 2.4(A) DISCLOSURES 99 Motion to Compel Discovery Relating to Past Damages (Attachments: # 1 Exhibit A, # 2 Exhibit B, # 3 Exhibit C)(Shimota, James) (Entered: 09/03/2014)
- 09/03/2014 110 RESPONSE by Audi of America, Inc.in Opposition to MOTION by Plaintiff Velocity Patent LLC for discovery OBJECTION TO ORDER REGARDING PLAINTIFF'S MOTION TO COMPEL LPR 2.1(B)(1) DISCLOSURES AND RESPONSES TO DISCOVERY AND PLAINTIFF'S MOTION TO COMPEL LPR 2.4(A) DISCLOSURES 99 (Attachments: # 1 Exhibit US 20120137658 (Sutton), # 2 Exhibit Excerpts from EMI-Global Website, # 3 Exhibit 2014-06-09 Audi Notice of Subpoena to TAS Distributing Co Inc, # 4 Exhibit 2014-08-26 TAS Distributing Responses to Mercedes Subpoena)(Williams, Ryan) (Entered: 09/03/2014)
- 09/15/2014 111 STATUS Report and Proposed Case Schedule by Audi of America, Inc. (Drake, Jeffrey) (Entered: 09/15/2014)
- 09/15/2014 112 MOTION by Plaintiff Velocity Patent LLC, Counter Defendant Velocity Patent LLC for leave to file Reply to Audi's Opposition to Motion to Compel Discovery Relating to Past Damages (Attachments: # 1 Exhibit 1, # 2 Exhibit 2, # 3 Exhibit 3, # 4 Exhibit 4, # 5 Exhibit 5, # 6 Exhibit 6, # 7 Exhibit A, # 8 Exhibit B, # 9 Exhibit C, # 10 Exhibit D, # 11 Exhibit E, # 12 Exhibit F, # 13 Exhibit G)(Shimota, James) (Entered: 09/15/2014)
- 09/15/2014 113 NOTICE of Motion by James A Shimota for presentment of motion for leave to file, 112 before Honorable John W. Darrah on 9/23/2014 at 09:30 AM. (Shimota, James) (Entered: 09/15/2014)
- 09/16/2014 114 MINUTE entry before the Honorable John W. Darrah: In court hearing and ruling on motion hearing held. Plaintiff's motion for leave to file Reply to Audi's Opposition to Motion to Compel Discovery Relating to Past Damages 112 is granted. No appearance needed on 9/23/14. Status hearing/ruling is set for 11/6/14 at 9:30 a.m. re: defendant's motion to stay 85 . Mailed notice(maf) (Entered: 09/16/2014)
- 09/16/2014 115 REPLY by Plaintiff Velocity Patent LLC, Counter Defendant Velocity Patent LLC to response in opposition to motion,, 110 (Attachments: # 1 Exhibit A, # 2 Exhibit B, # 3 Exhibit C, # 4 Exhibit D, # 5 Exhibit E, # 6 Exhibit F, # 7 Exhibit G)(Shimota, James) (Entered: 09/16/2014)
- 10/06/2014 116 MOTION by Defendant Audi of America, Inc. for leave to file Sur-Reply Brief (Attachments: # 1 Exhibit A)(Drake, Jeffrey) (Entered: 10/06/2014)



- 10/06/2014 117 NOTICE of Motion by Jeffrey Mark Drake for presentment of motion for leave to file 116 before Honorable John W. Darrah on 10/14/2014 at 09:30 AM. (Drake, Jeffrey) (Entered: 10/06/2014)
- 10/14/2014 119 ORDER: Ruling on motion hearing held. Defendant Audi's motion for leave to file Sur-Reply Brief is granted 116 . Brief to be filed by 10/21/14. Status hearing/ruling set for 11/6/14 is re-set to 12/11/14 at 9:30 a.m. Status hearing/ruling date of 12/4/14, stated on the record, is vacated. Signed by the Honorable John W. Darrah on 10/14/2014. Mailed notice (sxw) (Entered: 10/15/2014)
- 10/15/2014 118 SUR-REPLY by Defendant Audi of America, Inc. to reply, 115 to Velocity Patent's Objection to Magistrate Judge Mason's July 11, 2014 Order Granting-In Part Plaintiff's Motion to Compel (Drake, Jeffrey) (Entered: 10/15/2014)
- 10/21/2014 120 RESPONSE by Plaintiff Velocity Patent LLC, Counter Defendant Velocity Patent LLC to sur-reply 118 (Shimota, James) (Entered: 10/21/2014)
- 11/04/2014 121 MINUTE entry before the Honorable John W. Darrah: In court hearing set for 11/6/14 at 9:30 a.m. Mailed notice(maf) (Entered: 11/04/2014)
- 11/04/2014 122 ORDER: Status hearing/ruling on Defendant's Motion to Stay Pending Re-examination set for November 6, 2014 at 9:30 a.m. Signed by the Honorable John W. Darrah on 11/4/2014. Mailed notice (sxw) (Entered: 11/05/2014)
- 11/06/2014 123 ORDER: Status hearing held. Enter order to stay. Status hearing/ruling set for 12/11/14 at 9:30 a.m. to remain as scheduled. Signed by the Honorable John W. Darrah on 11/6/2014. Mailed notice (sxw) (Entered: 11/07/2014)
- 11/06/2014 124 STIPULATED Order. Signed by the Honorable John W. Darrah on 11/6/2014. Mailed notice (sxw) (Entered: 11/07/2014)
- 12/11/2014 125 MINUTE entry before the Honorable John W. Darrah: Defendant's Motion to Stay and Limit Discovery 54 is denied. Plaintiff's Motion to Compel LPR 2.4(a) Disclosures 80 is granted. The Court will rule by mail re: Defendant's Motion to Amend the Protective Order 40 . Status hearing set for 6/25/15 at 9:30 AM.Mailed notice(maf) (Entered: 12/12/2014)
- 12/11/2014 126 ORDER: Status hearing and ruling on motion hearing held. For the reasons stated in the attached memorandum opinion and order, Audi is hereby ordered to produce discovery relating to past damages for the period beginning six years prior to the filing date of the Complaint, November 21, 2013. Enter Memorandum Opinion and Order. Signed by the Honorable John W. Darrah on 12/11/2014. Mailed notice (mmy, ) (Entered: 12/12/2014)
- 12/11/2014 127 MEMORANDUM Opinion and Order Signed by the Honorable John W. Darrah on 12/11/2014. Mailed notice (mmy, ) (Entered: 12/12/2014)
- 01/21/2015 128 ORDER: For the reasons stated in the attached memorandum opinion and order, Audi's Motion to Amend Protective Order 40 is denied. Enter Memorandum Opinion and Order. Signed by the Honorable John W. Darrah on 1/21/2015. Mailed notice (sxw) (Entered: 01/21/2015)
- 01/21/2015 129 MEMORANDUM Opinion and Order. Signed by the Honorable John W. Darrah on 1/21/2015. Mailed notice (sxw) (Entered: 01/21/2015)
- 01/29/2015 130 MINUTE entry before the Honorable Michael T. Mason:Parties to report to this Court's chambers, room 2270, following the 6/25/15 status hearing before the District Court. (rbf, ) (Entered: 01/29/2015)
- 02/12/2015 131 TRANSCRIPT OF PROCEEDINGS held on 12/11/14 before the Honorable John W. Darrah. Court Reporter Contact Information: Mary M. Hacker, (312) 435-5564, Mary\_Hacker@ilnd.uscourts.gov. IMPORTANT: The transcript may be viewed at the court's public terminal or purchased

through the Court Reporter/Transcriber before the deadline for Release of Transcript Restriction. After that date it may be obtained through the Court Reporter/Transcriber or PACER. For further information on the redaction process, see the Court's web site at [www.ilnd.uscourts.gov](http://www.ilnd.uscourts.gov) under Quick Links select Policy Regarding the Availability of Transcripts of Court Proceedings. Redaction Request due 3/5/2015. Redacted Transcript Deadline set for 3/16/2015. Release of Transcript Restriction set for 5/13/2015. (Hacker, Mary) (Entered: 02/12/2015)

---

Copyright © 2015 LexisNexis CourtLink, Inc. All rights reserved.  
\*\*\* THIS DATA IS FOR INFORMATIONAL PURPOSES ONLY \*\*\*

---

**US District Court Civil Docket**

U.S. District - Illinois Northern  
(Chicago)

**1:13cv8419**

**Velocity Patent Llc v. Chrysler Group, Llc**

**This case was retrieved from the court on Monday, March 23, 2015**

---

<b>Date Filed:</b> 11/21/2013	<b>Class Code:</b> OPEN
<b>Assigned To:</b> Honorable John W. Darrah	<b>Closed:</b>
<b>Referred To:</b>	<b>Statute:</b> 35:271
<b>Nature of suit:</b> Patent (830)	<b>Jury Demand:</b> Both
<b>Cause:</b> Patent Infringement	<b>Demand Amount:</b> \$0
<b>Lead Docket:</b> None	<b>NOS Description:</b> Patent
<b>Other Docket:</b> 1:13cv08413	
<b>Jurisdiction:</b> Federal Question	

**Litigants**

**Attorneys**

Velocity Patent Llc  
Plaintiff

Aaron Charles Taggart  
ATTORNEY TO BE NOTICED  
Mavrakakis Law Group LLP  
180 N. LaSalle Suite 2215  
Chicago, IL 60601  
USA  
(312) 216-1627  
Email:Ataggart@mavllp.Com

Adam Robert Brausa  
[Term: 06/02/2014]  
Mavrakakis Law Group LLP  
180 North LaSalle Street Suite 2215  
Chicago, IL 60601  
USA  
(312) 216-1626  
Email:Abrausa@mavllp.Com

Howard E Levin  
ATTORNEY TO BE NOTICED  
Mavrakakis Law Group LLP  
180 N. LaSalle Suite 2215  
Chicago, IL 60601  
USA  
312-216-1620  
Fax: (630) 881-7438  
Email:Hlevin@mavllp.Com

James A Shimota  
ATTORNEY TO BE NOTICED  
Mavrakakis Law Group LLP

Chrysler Group, Llc  
Defendant

180 N. Lasalle Suite 2215  
Chicago , IL 60601  
USA  
(312) 216-1626  
Fax: (773)661-2555  
Email:Jshimota@mavllp.Com

Brian William Bell  
ATTORNEY TO BE NOTICED  
Swanson, Martin & Bell  
330 North Wabash Suite 3300  
Chicago , IL 60611  
USA  
(312) 321-9100  
Email:Bbell@smbtrials.Com

Charles J. Monterio , Jr.  
PRO HAC VICE;ATTORNEY TO BE NOTICED  
Dickstein Shapiro Llp  
1825 Eye Street Nw  
Washington , DC 20006  
USA  
(202) 420-2200  
Email:Monterioc@dicksteinshapiro.Com

Frank C Cimino , Jr.  
ATTORNEY TO BE NOTICED  
Dickstein Shapiro LLP  
1825 Eye Street Nw  
(202) 912 - 5000  
Washington , DC 20006  
USA  
Email:Ciminof@dicksteinshapiro.Com

Jonna McGinley Reilly  
ATTORNEY TO BE NOTICED  
Swanson, Martin & Bell LLP  
330 N. Wabash Suite 3300  
Chicago , IL 60611  
USA  
(312) 321-9100  
Email:Jreilly@smbtrials.Com

Marla Harumi Kanemitsu  
[Term: 12/11/2014]  
Dickstein Shapiro LLP  
1825 Eye Street, Nw  
Washington , DC 20006  
USA  
(202) 420-4859  
Email:Kanemitsum@dicksteinshapiro.Com

P. Stephen Fardy  
ATTORNEY TO BE NOTICED  
Swanson, Martin & Bell  
330 North Wabash Suite 3300  
Chicago , IL 60611  
USA  
(312) 321-9100  
Email:Sfardy@smbtrials.Com

Date	#	Proceeding Text	Source
11/21/2013	1	COMPLAINT filed by Velocity Patent LLC; Jury Demand. Filing fee \$ 400, receipt number 0752-8957934. (Attachments: # 1 Errata Ex. A)(Shimota, James) (Entered: 11/21/2013)	
11/21/2013	2	CIVIL Cover Sheet (Shimota, James) (Entered: 11/21/2013)	
11/21/2013	3	ATTORNEY Appearance for Plaintiff Velocity Patent LLC by James A Shimota (Shimota, James) (Entered: 11/21/2013)	
11/21/2013		CASE ASSIGNED to the Honorable Edmond E. Chang. Designated as Magistrate Judge the Honorable Maria Valdez. (nsf, ) (Entered: 11/21/2013)	
11/21/2013	4	ATTORNEY Appearance for Plaintiff Velocity Patent LLC by Howard E Levin (Levin, Howard) (Entered: 11/21/2013)	
11/21/2013	5	ATTORNEY Appearance for Plaintiff Velocity Patent LLC by Adam Robert Brausa (Brausa, Adam) (Entered: 11/21/2013)	
11/21/2013		SUMMONS Issued as to Defendant Chrysler Group, LLC (pg, ) (Entered: 11/21/2013)	
11/21/2013	6	NOTIFICATION of Affiliates pursuant to Local Rule 3.2 by Velocity Patent LLC (Shimota, James) (Entered: 11/21/2013)	
11/21/2013	7	Notice of Claims Involving Patents Pursuant to Rule 3.4 by Velocity Patent LLC (Shimota, James) (Entered: 11/21/2013)	
11/22/2013	8	MAILED patent report to Patent Trademark Office, Alexandria VA (tg, ) (Entered: 11/22/2013)	
11/22/2013	9	MINUTE entry before the Honorable Edmond E. Chang: Status hearing set for February 6, 2014 at 8:30 a.m. The parties must file a joint initial status report with the content described in the attached status report requirements at least 3 business days before the initial status hearing. Plaintiff must still file the report even if not all Defendants have been served or have responded to requests to craft a joint report. Additionally, the parties must read Judge Chang's Case Management Procedures on the Court's website; those Procedures are considered standing orders in this case.Mailed notice (Attachments: # 1 Status Report Requirements) (slb, ) (Entered: 11/22/2013)	
12/02/2013	10	SUMMONS Returned Executed by Velocity Patent LLC as to Chrysler Group, LLC on 11/22/2013, answer due 12/13/2013. (Shimota, James) (Entered: 12/02/2013)	
12/02/2013	11	MINUTE entry before the Honorable Edmond E. Chang: The status hearing of 2/6/2014 is reset to 1/7/2014 at 9:30 a.m. The status report is due at least 3 business days before the initial status hearing. Mailed notice (slb, ) (Entered: 12/02/2013)	
12/03/2013	12	MINUTE entry before the Honorable Edmond E. Chang: Plaintiff's counsel called the courtroom deputy to say that Plaintiff had intended to check the box on the Civil Cover Sheet form that states there is a related case (13 C 08413) in Section IX of the form. Counsel asked whether there was a way to administratively correct the form in order to have the case reassigned as related; counsel was instructed to file a motion (where all parties may weigh in) rather than rely on some other mechanism. Mailed notice (slb, ) (Entered: 12/03/2013)	
12/04/2013	13	ATTORNEY Appearance for Plaintiff Velocity Patent LLC by Aaron Charles Taggart (Taggart, Aaron) (Entered: 12/04/2013)	
12/11/2013	14	ATTORNEY Appearance for Defendant Chrysler Group, LLC by Marla Harumi Kanemitsu (Kanemitsu, Marla) (Entered: 12/11/2013)	

- 12/11/2013 15 MOTION by Defendant Chrysler Group, LLC for extension of time to file answer regarding complaint 1 (Attachments: # 1 Unopposed Motion for a 45 day Extension of Time)(Kanemitsu, Marla) (Entered: 12/11/2013)
- 12/12/2013 16 MOTION for Leave to Appear Pro Hac Vice Filing fee \$ 50, receipt number 0752-9017144. (Cimino, Frank) (Entered: 12/12/2013)
- 12/19/2013 17 MINUTE entry before the Honorable Edmond E. Chang: Defendant's unopposed extension motion 15 to answer is granted to 01/27/2014. The motion to proceed pro hac vice 16 is granted. With regard to noticing-up motions, the extension motion did not appear on the CM/ECF system for some reason. (lcw, ) (Entered: 12/19/2013)
- 12/23/2013 18 MINUTE entry before the Honorable Edmond E. Chang: In light of the new answer deadline, the status hearing of 01/07/2014 is reset to 02/06/2014 at 8:30 a.m. The joint written status report is due on 02/03/2014. (lcw, ) (Entered: 12/23/2013)
- 01/06/2014 19 MOTION for Leave to Appear Pro Hac Vice Filing fee \$ 50, receipt number 0752-9073340. (Monterio, Charles) (Entered: 01/06/2014)
- 01/07/2014 20 ATTORNEY Appearance for Defendant Chrysler Group, LLC by P. Stephen Fardy (Attachments: # 1 Certificate of Service)(Fardy, P.) (Entered: 01/07/2014)
- 01/07/2014 21 ATTORNEY Appearance for Defendant Chrysler Group, LLC by Brian William Bell (Attachments: # 1 Certificate of Service)(Bell, Brian) (Entered: 01/07/2014)
- 01/07/2014 22 EXECUTIVE COMMITTEE ORDER: Case reassigned to the Honorable John W. Darrah for all further proceedings. Signed by Executive Committee on 1/7/2014. (tg, ) (Entered: 01/08/2014)
- 01/10/2014 23 MINUTE entry before the Honorable John W. Darrah: Status hearing set for 4/10/14 at 9:30 a.m. Mailed notice(maf) (Entered: 01/10/2014)
- 01/27/2014 24 ANSWER to Complaint with Jury Demand by Chrysler Group, LLC(Fardy, P.) (Entered: 01/27/2014)
- 02/04/2014 25 NOTICE by James A Shimota of Change of Address (Shimota, James) (Entered: 02/04/2014)
- 02/04/2014 26 NOTICE by Howard E Levin of Change of Address (Levin, Howard) (Entered: 02/04/2014)
- 02/04/2014 27 NOTICE by Aaron Charles Taggart of Change of Address (Taggart, Aaron) (Entered: 02/04/2014)
- 02/04/2014 28 NOTICE by Adam Robert Brausa of Change of Address (Brausa, Adam) (Entered: 02/04/2014)
- 02/24/2014 29 Updated Corporate Disclosure by Chrysler Group, LLC (Fardy, P.) (Entered: 02/24/2014)
- 04/03/2014 30 REPORT of Rule 26(f) Planning Meeting (Attachments: # 1 Exhibit 1) (Shimota, James) (Entered: 04/03/2014)
- 04/10/2014 31 ORDER : Status hearing held and continued to 4/17/14 at 9:30 a.m. Joint claim construction chart and status report to be filed by 2/15/15. Claim construction hearing is set for 3/11/15 at 1:30 p.m. Signed by the Honorable John W. Darrah on 4/10/2014. Mailed notice (tg, ) (Entered: 04/11/2014)
- 04/17/2014 32 MINUTE entry before the Honorable John W. Darrah: Status hearing held and continued to 4/24/14 at 9:30 a.m.Mailed notice(maf) (Entered: 04/17/2014)
- 04/21/2014 33 ORDER: Pro hac vice motion is granted 19 . Signed by the Honorable John W. Darrah on 4/21/2014. Mailed notice (tg, ) (Entered: 04/21/2014)
- 04/24/2014 34 MINUTE entry before the Honorable John W. Darrah: Status hearing held

- and continued to 5/7/14 at 9:30 a.m. Mailed notice(maf) (Entered: 04/24/2014)
- 05/07/2014 35 MINUTE entry before the Honorable John W. Darrah: Status hearing held and continued to 8/19/14 at 9:30 a.m. Mailed notice(maf) (Entered: 05/07/2014)
- 05/30/2014 36 MOTION by counsel for Plaintiff Velocity Patent LLC to withdraw as attorney Adam R. Brausa (Shimota, James) (Entered: 05/30/2014)
- 05/30/2014 37 NOTICE of Motion by James A Shimota for presentment of motion to withdraw as attorney 36 before Honorable John W. Darrah on 6/5/2014 at 09:30 AM. (Shimota, James) (Entered: 05/30/2014)
- 06/02/2014 38 MINUTE entry before the Honorable John W. Darrah: Plaintiff's Motion to Withdraw Counsel Adam R. Brausa 36 is granted. No appearances necessary on June 5, 2014. All other dates remain as scheduled. Mailed notice(maf) (Entered: 06/02/2014)
- 08/18/2014 39 ATTORNEY Appearance for Defendant Chrysler Group, LLC by Jonna McGinley Reilly (McGinley Reilly, Jonna) (Entered: 08/18/2014)
- 08/19/2014 40 MINUTE entry before the Honorable John W. Darrah: Status hearing held and continued to 9/16/14 at 9:30 a.m. Mailed notice(maf) (Entered: 08/19/2014)
- 09/16/2014 41 MINUTE entry before the Honorable John W. Darrah: Status hearing held and continued to 3/31/15 at 9:30 a.m. Claim construction hearing set for 3/11/15 is vacated. Mailed notice(maf) (Entered: 09/16/2014)
- 11/04/2014 42 MINUTE entry before the Honorable John W. Darrah: In court hearing set for 11/6/14 at 9:30 a.m. Mailed notice(maf) (Entered: 11/04/2014)
- 11/04/2014 43 ORDER: Status hearing set for November 6, 2014 at 9:30 a.m. Signed by the Honorable John W. Darrah on 11/4/2014. Mailed notice. (as, ) (Entered: 11/05/2014)
- 11/06/2014 44 STIPULATED ORDER signed by the Honorable John W. Darrah on 11/6/2014. Mailed notice. (as, ) (Entered: 11/07/2014)
- 12/05/2014 45 MOTION by Defendant Chrysler Group, LLC to withdraw attorney appearance 14 (Attachments: # 1 Text of Proposed Order)(Fardy, P.) (Entered: 12/05/2014)
- 12/05/2014 46 NOTICE of Motion by P. Stephen Fardy for presentment of before Honorable John W. Darrah on 12/11/2014 at 09:30 AM. (Fardy, P.) (Entered: 12/05/2014)
- 12/11/2014 47 MINUTE entry before the Honorable John W. Darrah: Ruling on motion hearing held. Defendant's motion to withdraw the appearance of Marla Harumi Kanemitsu 45 is granted. Mailed notice(maf) (Entered: 12/11/2014)
- 12/12/2014 48 MINUTE entry before the Honorable John W. Darrah: Claim construction hearing is set for 3/11/15 is vacated. Status hearing set for 6/25/15 at 9:30 a.m. Mailed notice(maf) (Entered: 12/12/2014)

---

Copyright © 2015 LexisNexis CourtLink, Inc. All rights reserved.  
\*\*\* THIS DATA IS FOR INFORMATIONAL PURPOSES ONLY \*\*\*

---

**US District Court Civil Docket**U.S. District - Illinois Northern  
(Chicago)**1:13cv8421****Velocity Patent Llc v. Jaguar Land Rover North America, Llc****This case was retrieved from the court on Monday, March 23, 2015**

---

**Date Filed: 11/21/2013**  
**Assigned To: Honorable John W. Darrah**  
**Referred To:**  
**Nature of suit: Patent (830)**  
**Cause: Patent Infringement**  
**Lead Docket: None**  
**Other Docket: None**  
**Jurisdiction: Federal Question**

**Class Code: CLOSED**  
**Closed: 08/26/2014**  
**Statute: 35:271**  
**Jury Demand: Both**  
**Demand Amount: \$0**  
**NOS Description: Patent**

**Litigants**Velocity Patent Llc  
Plaintiff**Attorneys**James A Shimota  
LEAD ATTORNEY;ATTORNEY TO BE NOTICED  
Mavrakakis Law Group LLP  
180 N. LaSalle Suite 2215  
Chicago , IL 60601  
USA  
(312) 216-1626  
Fax: (773)661-2555  
Email:Jshimota@mavllp.ComAaron Charles Taggart  
ATTORNEY TO BE NOTICED  
Mavrakakis Law Group LLP  
180 N. LaSalle Suite 2215  
Chicago , IL 60601  
USA  
(312) 216-1627  
Email:Ataggart@mavllp.ComAdam Robert Brausa  
[Term: 06/02/2014]  
Mavrakakis Law Group LLP  
180 North LaSalle Street Suite 2215  
Chicago , IL 60601  
USA  
(312) 216-1626  
Email:Abrausa@mavllp.ComHoward E Levin  
ATTORNEY TO BE NOTICED  
Mavrakakis Law Group LLP



180 N. Lasalle Suite 2215  
Chicago , IL 60601  
USA  
312-216-1620  
Fax: (630) 881-7438  
Email:Hlevin@mavllp.Com

Jaguar Land Rover North America, Llc  
Defendant

Cassius K. Sims  
PRO HAC VICE;ATTORNEY TO BE NOTICED  
Latham & Watkins LLP  
885 Third Avenue  
New York , NY 10022  
USA  
(212) 906-1200  
Email:Cassius.Sims@lw.Com

Clement Joseph Naples  
PRO HAC VICE;ATTORNEY TO BE NOTICED  
Latham & Watkins LLP  
885 Third Avenue  
New York , NY 10022  
USA  
(212) 906-1200  
Email:Clement.Naples@lw.Com

Kristopher R. Davis  
ATTORNEY TO BE NOTICED  
Latham & Watkins LLP  
330 N. Wabash Avenue Suite 2800  
Chicago , IL 60611  
USA  
(312) 876-7700  
Fax: (312) 993-9767  
Email:Kris.Davis@lw.Com

Matthew John Moore  
PRO HAC VICE;ATTORNEY TO BE NOTICED  
Latham & Watkins LLP  
555 Eleventh Street Nw Suite 1000  
Washington , DC 20004  
USA  
(202) 637-2200  
Email:Matthew.Moore@lw.Com

Date	#	Proceeding Text	Source
11/21/2013	1	COMPLAINT filed by Velocity Patent LLC; Jury Demand. Filing fee \$ 400, receipt number 0752-8958007. (Attachments: # 1 Exhibit Ex. A)(Shimota, James) (Entered: 11/21/2013)	
11/21/2013	2	CIVIL Cover Sheet (Shimota, James) (Entered: 11/21/2013)	
11/21/2013	3	ATTORNEY Appearance for Plaintiff Velocity Patent LLC by James A Shimota (Shimota, James) (Entered: 11/21/2013)	
11/21/2013		CASE ASSIGNED to the Honorable Robert W. Gettleman. Designated as Magistrate Judge the Honorable Jeffrey T. Gilbert. (nsf, ) (Entered: 11/21/2013)	
11/21/2013	4	ATTORNEY Appearance for Plaintiff Velocity Patent LLC by Howard E Levin (Levin, Howard) (Entered: 11/21/2013)	

- 11/21/2013 5 ATTORNEY Appearance for Plaintiff Velocity Patent LLC by Adam Robert Brausa (Brausa, Adam) (Entered: 11/21/2013)
- 11/21/2013 SUMMONS Issued as to Defendant Jaguar Land Rover North America, LLC (pg, ) (Entered: 11/21/2013)
- 11/21/2013 6 NOTIFICATION of Affiliates pursuant to Local Rule 3.2 by All Plaintiffs (Shimota, James) (Entered: 11/21/2013)
- 11/21/2013 7 Rule 3.4 Notice of Claims Involving Patents by Velocity Patent LLC (Shimota, James) (Entered: 11/21/2013)
- 11/22/2013 8 MAILED patent report to Patent Trademark Office, Alexandria VA. (tlm) (Entered: 11/22/2013)
- 11/25/2013 9 ORDER the Clerk is to arrange for this case to be transferred to the Patent Case Pilot Program, signed by the Honorable Robert W. Gettleman on 11/25/2013: Mailed notice (gds) (Entered: 11/25/2013)
- 11/26/2013 10 EXECUTIVE COMMITTEE ORDER: It appearing that 13 C 8421, Velocity Patent LLC v. Jaguar Land Rover North America LLC, pending before the Hon. Robert W. Gettleman, has been identified for transfer to the Patent Case Pilot Program in which this Court is participating, therefore It is hereby ordered that 13 C 8421, Velocity Patent LLC v. Jaguar Land Rover North America LLC,, is to be reassigned by lot to one of the district judges participating in the pilot program. Case reassigned to the Honorable Elaine E. Bucklo for all further proceedings. Signed by Executive Committee on 11/26/2013. (td, ) (Entered: 11/26/2013)
- 12/02/2013 11 SUMMONS Returned Executed by Velocity Patent LLC as to Jaguar Land Rover North America, LLC on 11/22/2013, answer due 12/13/2013. (Shimota, James) (Entered: 12/02/2013)
- 12/04/2013 12 ATTORNEY Appearance for Plaintiff Velocity Patent LLC by Aaron Charles Taggart (Taggart, Aaron) (Entered: 12/04/2013)
- 12/10/2013 13 ATTORNEY Appearance for Defendant Jaguar Land Rover North America, LLC by Kristopher R. Davis (Davis, Kristopher) (Entered: 12/10/2013)
- 12/10/2013 14 NOTIFICATION of Affiliates pursuant to Local Rule 3.2 by Jaguar Land Rover North America, LLC (Davis, Kristopher) (Entered: 12/10/2013)
- 12/10/2013 15 MOTION by Defendant Jaguar Land Rover North America, LLC for extension of time to file answer regarding complaint 1 - Defendant's Unopposed Motion for Extension of Time to Answer or Otherwise Plead (Davis, Kristopher) (Entered: 12/10/2013)
- 12/10/2013 16 NOTICE of Motion by Kristopher R. Davis for presentment of motion for extension of time to file answer, motion for relief 15 before Honorable Elaine E. Bucklo on 12/17/2013 at 09:30 AM. (Davis, Kristopher) (Entered: 12/10/2013)
- 12/11/2013 17 MOTION for Leave to Appear Pro Hac Vice Filing fee \$ 50, receipt number 0752-9012819. (Sims, Cassius) (Entered: 12/11/2013)
- 12/11/2013 18 MOTION for Leave to Appear Pro Hac Vice Filing fee \$ 50, receipt number 0752-9013079. (Naples, Clement) (Entered: 12/11/2013)
- 12/11/2013 19 MOTION for Leave to Appear Pro Hac Vice Filing fee \$ 50, receipt number 0752-9014790. (Moore, Matthew) (Entered: 12/11/2013)
- 12/16/2013 20 MINUTE entry before the Honorable Elaine E. Bucklo: Defendant's Unopposed Motion for extension of time until 1/27/2014 to answer or otherwise plead 15 is granted. Application to appear pro hac vice of Cassius Sims 17 , Clement J. Naples 18 and Matthew J. Moore 19 as counsel for defendant are granted. Scheduling Conference set for 1/31/2014 at 9:30 AM. Mailed notice (jdh) (Entered: 12/16/2013)
- 01/07/2014 21 EXECUTIVE COMMITTEE ORDER: Case reassigned to the Honorable John W. Darrah for all further proceedings. Related Case No. 13cv8413. Entered

- by Executive Committee on 1/7/14.(gcy, ) (Entered: 01/08/2014)
- 01/10/2014 22 MINUTE entry before the Honorable John W. Darrah: Status hearing set for 4/10/14 at 9:30 a.m. Mailed notice(maf) (Entered: 01/10/2014)
- 01/27/2014 23 ANSWER to Complaint with Jury Demand by Jaguar Land Rover North America, LLC(Davis, Kristopher) (Entered: 01/27/2014)
- 01/28/2014 24 MINUTE entry before the Honorable Elaine E. Bucklo: This case having been reassigned to Judge Darrah, the scheduling conference set for 1/31/2014 before Judge Bucklo is stricken. Mailed notice (jdh) (Entered: 01/28/2014)
- 02/04/2014 25 NOTICE by James A Shimota of Change of Address (Shimota, James) (Entered: 02/04/2014)
- 02/04/2014 26 NOTICE by Howard E Levin of Change of Address (Levin, Howard) (Entered: 02/04/2014)
- 02/04/2014 27 NOTICE by Aaron Charles Taggart of Change of Address (Taggart, Aaron) (Entered: 02/04/2014)
- 02/04/2014 28 NOTICE by Adam Robert Brausa of Change of Address (Brausa, Adam) (Entered: 02/04/2014)
- 04/03/2014 29 REPORT of Rule 26(f) Planning Meeting (Attachments: # 1 Exhibit 1) (Shimota, James) (Entered: 04/03/2014)
- 04/10/2014 30 ORDER: Status hearing held and continued to 4/17/14 at 9:30 a.m. Joint claim construction chart and status report to be filed by 2/15/15. Claim Construction hearing is set for 3/11/15 at 1:30 p.m. Signed by the Honorable John W. Darrah on 4/10/2014.(gcy, ) (Entered: 04/11/2014)
- 04/11/2014 31 MINUTE entry before the Honorable John W. Darrah: The Court's 4/10/14 order is amended to reflect the following: Joint claim construction chart and status report to be filed by 2/25/15. Mailed notice(maf) (Entered: 04/11/2014)
- 04/17/2014 32 MINUTE entry before the Honorable John W. Darrah: Status hearing held and continued to 4/24/14 at 9:30 a.m.Mailed notice(maf) (Entered: 04/17/2014)
- 04/24/2014 33 MINUTE entry before the Honorable John W. Darrah: Status hearing held and continued to 5/7/14 at 9:30 a.m. Mailed notice(maf) (Entered: 04/24/2014)
- 05/07/2014 34 MINUTE entry before the Honorable John W. Darrah: Status hearing held and continued to 8/19/14 at 9:30 a.m. Mailed notice(maf) (Entered: 05/07/2014)
- 05/30/2014 35 MOTION by counsel for Plaintiff Velocity Patent LLC to withdraw as attorney Adam R. Brausa (Shimota, James) (Entered: 05/30/2014)
- 05/30/2014 36 NOTICE of Motion by James A Shimota for presentment of motion to withdraw as attorney 35 before Honorable John W. Darrah on 6/5/2014 at 09:30 AM. (Shimota, James) (Entered: 05/30/2014)
- 06/02/2014 37 MINUTE entry before the Honorable John W. Darrah: Plaintiff's Motion to Withdraw Counsel Adam R. Brausa 36 is granted. No appearances necessary on June 5, 2014. All other dates remain as scheduled. Mailed notice(maf) (Entered: 06/02/2014)
- 06/18/2014 38 MOTION by counsel for Defendant Jaguar Land Rover North America, LLC to withdraw as attorney - Motion for Leave to Withdraw Cassius K. Sims as Attorney (Davis, Kristopher) (Entered: 06/18/2014)
- 06/18/2014 39 NOTICE of Motion by Kristopher R. Davis for presentment of motion to withdraw as attorney 38 before Honorable John W. Darrah on 6/26/2014 at 09:30 AM. (Davis, Kristopher) (Entered: 06/18/2014)
- 06/19/2014 40 ORDER: Defendant's Motion to Withdraw as Cassius K. Sims 38 is granted.

No appearance necessary on June 26, 2014. All other dates remain as scheduled.Signed by the Honorable John W. Darrah. (gcy, ) (Entered: 06/19/2014)

- 08/19/2014 41 MINUTE entry before the Honorable John W. Darrah: Status hearing held and continued to 9/16/14 at 9:30 a.m. Mailed notice(maf) (Entered: 08/19/2014)
- 08/25/2014 42 STIPULATION of Dismissal Joint Motion to Dismiss with Prejudice (Shimota, James) (Entered: 08/25/2014)
- 08/26/2014 43 ORDER: before the Honorable John W. Darrah: Enter agreed order of dismissal. Civil case closed. Any pending dates or motions are moot. Civil case terminated. (gcy, ) (Entered: 08/27/2014)
- 08/26/2014 44 ORDER OF DISMISSAL Entered by the Honorable John W. Darrah on 8/26/2014.(gcy, ) (Entered: 08/27/2014)
- 08/27/2014 45 MAILED certified copy of Closing Order with Patent report to Patent Trademark Office, Alexandria VA. (gcy, ) (Entered: 08/27/2014)

---

Copyright © 2015 LexisNexis CourtLink, Inc. All rights reserved.  
\*\*\* THIS DATA IS FOR INFORMATIONAL PURPOSES ONLY \*\*\*



UNITED STATES PATENT AND TRADEMARK OFFICE

UNITED STATES DEPARTMENT OF COMMERCE  
United States Patent and Trademark Office  
Address: COMMISSIONER FOR PATENTS  
P. O. Box 1450  
Alexandria, Virginia 22313-1450  
www.uspto.gov

APPLICATION NO.	FILING DATE	FIRST NAMED INVENTOR	ATTORNEY DOCKET NO.	CONFIRMATION NO.
90/013,252	05/22/2014	5,954,781		9999

88360 7590 03/17/2015  
Richards Patent Law P.C.  
233 S. Wacker Dr., 84th Floor  
Chicago, IL 60606

EXAMINER

ENGLAND, DAVID E

ART UNIT	PAPER NUMBER
3992	

MAIL DATE	DELIVERY MODE
03/17/2015	PAPER

**Please find below and/or attached an Office communication concerning this application or proceeding.**

The time period for reply, if any, is set in the attached communication.

<b>Examiner-Initiated Interview Summary</b>	<b>Application No.</b>	<b>Applicant(s)</b>	
	90/013,252	5,954,781	
	<b>Examiner</b>	<b>Art Unit</b>	
	DAVID ENGLAND	3992	

All participants (applicant, applicant's representative, PTO personnel):

- (1) DAVID ENGLAND. (3) JENNIFER MCNEIL (SPE).  
(2) ALISHA TAYLOR Reg. No. 59332. (4) MICHAEL YIGDALL.

Date of Interview: 11 March 2015.

Type:  Telephonic  Video Conference  
 Personal [copy given to:  applicant  applicant's representative]

Exhibit shown or demonstration conducted:  Yes  No.  
If Yes, brief description: \_\_\_\_\_.

Issues Discussed  101  112  102  103  Others  
(For each of the checked box(es) above, please describe below the issue and detailed description of the discussion)

Claim(s) discussed: 33-60 and 85-114.

Identification of prior art discussed: NA.

**Substance of Interview**

(For each issue discussed, provide a detailed description and indicate if agreement was reached. Some topics may include: identification or clarification of a reference or a portion thereof, claim interpretation, proposed amendments, arguments of any applied references etc...)

Examiner England contacted Attorney Taylor to discuss multiple amendment errors and 112 issues. All new claims need to state they are new and with those that are amended, how many times they are amended. Further, new claims need to always be underlined. Claims 38, 54, 88 and 106 claim a "means for mode selection" that invokes 112 6<sup>th</sup> paragraph. There is no structure that supports this language. As found in column 7, lines 47 - 58, what is discussed is a "mode select line" but it is not clear as to what structure is that would define the means. Examiner recommended amending the claims to state a mode select input line for switching between the active mode and inactive mode instead of a "means for" doing such. This could overcome a 112 second paragraph rejection if amended correctly .

**Applicant recordation instructions:** It is not necessary for applicant to provide a separate record of the substance of interview.

**Examiner recordation instructions:** Examiners must summarize the substance of any interview of record. A complete and proper recordation of the substance of an interview should include the items listed in MPEP 713.04 for complete and proper recordation including the identification of the general thrust of each argument or issue discussed, a general indication of any other pertinent matters discussed regarding patentability and the general results or outcome of the interview, to include an indication as to whether or not agreement was reached on the issues raised.

Attachment

/DAVID ENGLAND/  
Primary Examiner, Art Unit 3992

<b>Examiner-Initiated Interview Summary</b>	<b>Application No.</b>	<b>Applicant(s)</b>	
	90/013,252	5,954,781	
	<b>Examiner</b>	<b>Art Unit</b>	
	DAVID ENGLAND	3992	

All participants (applicant, applicant's representative, PTO personnel):

- (1) DAVID ENGLAND. (3) JENNIFER MCNEIL (SPE).  
(2) ALISHA TAYLOR Reg. No. 59332. (4) MICHAEL YIGDALL.

Date of Interview: 11 March 2015.

Type:  Telephonic  Video Conference  
 Personal [copy given to:  applicant  applicant's representative]

Exhibit shown or demonstration conducted:  Yes  No.  
If Yes, brief description: \_\_\_\_\_.

Issues Discussed  101  112  102  103  Others  
(For each of the checked box(es) above, please describe below the issue and detailed description of the discussion)

Claim(s) discussed: 33-60 and 85-114.

Identification of prior art discussed: NA.

**Substance of Interview**

(For each issue discussed, provide a detailed description and indicate if agreement was reached. Some topics may include: identification or clarification of a reference or a portion thereof, claim interpretation, proposed amendments, arguments of any applied references etc...)

Examiner England contacted Attorney Taylor to discuss multiple amendment errors and 112 issues. All new claims need to state they are new and with those that are amended, how many times they are amended. Further, new claims need to always be underlined. Claims 38, 54, 88 and 106 claim a "means for mode selection" that invokes 112 6<sup>th</sup> paragraph. There is no structure that supports this language. As found in column 7, lines 47 - 58, what is discussed is a "mode select line" but it is not clear as to what structure is that would define the means. Examiner recommended amending the claims to state a mode select input line for switching between the active mode and inactive mode instead of a "means for" doing such. This could overcome a 112 second paragraph rejection if amended correctly .

**Applicant recordation instructions:** It is not necessary for applicant to provide a separate record of the substance of interview.

**Examiner recordation instructions:** Examiners must summarize the substance of any interview of record. A complete and proper recordation of the substance of an interview should include the items listed in MPEP 713.04 for complete and proper recordation including the identification of the general thrust of each argument or issue discussed, a general indication of any other pertinent matters discussed regarding patentability and the general results or outcome of the interview, to include an indication as to whether or not agreement was reached on the issues raised.

Attachment

/DAVID ENGLAND/  
Primary Examiner, Art Unit 3992

<b>Reexamination</b> 	<b>Application/Control No.</b> 90013252	<b>Applicant(s)/Patent Under Reexamination</b> 5,954,781
	<b>Certificate Date</b>	<b>Certificate Number</b>

<b>Requester Correspondence Address:</b>	<input type="checkbox"/> <b>Patent Owner</b>	<input checked="" type="checkbox"/> <b>Third Party</b>
KENYON & KENYON LLP ONE BROADWAY NEW YORK, NY 10004		

<b>LITIGATION REVIEW</b> <input type="checkbox"/>	/DE/ (examiner initials)	10/06/2014 (date)
Case Name		Director Initials
1:13cv8413 (OPEN)		
1:13cv8416 (OPEN)		
1:13cv8418 (OPEN)		
1:13cv8419 (OPEN)		
1:13cv8421 (OPEN)		

<b>COPENDING OFFICE PROCEEDINGS</b>	
<b>TYPE OF PROCEEDING</b>	<b>NUMBER</b>

--	--



Docket No. 1089-001

**PATENT**

**IN THE UNITED STATES PATENT AND TRADEMARK OFFICE**

**Control No.** : 90013252                      **Confirmation No.** : 9999  
**Patent No.** : 5,954,781  
**Applicant** : Harvey Slepian  
**Reexam Filed:** May 22, 2014  
**Art Unit.** : 3992  
**Examiner** : David E. England  
**Customer No.:** 88360

Commissioner for Patents  
P.O. Box 1450  
Alexandria, VA 22313-1450

**RESPONSE**

Sir:

This Amendment is being submitted in the above-identified Reexamination.

Please amend the above-identified application as follows:

**Amendments to the Claims** are reflected in the listing of claims, which begins on page 2 of this paper.

**Remarks/Arguments** begin on page 33 of this paper.

### **Amendments to the Claims**

This listing of claims will replace all prior versions, and listings, of claims in the application:

#### **Listing of Claims**

1. (Original) Apparatus for optimizing operation of a vehicle, comprising:

a plurality of sensors coupled to a vehicle having an engine, said plurality of sensors, which collectively monitor operation of said vehicle, including a road speed sensor, an engine speed sensor, a manifold pressure sensor and a throttle position sensor;

a processor subsystem, coupled to each one of said plurality of sensors, to receive data therefrom;

a memory subsystem, coupled to said processor subsystem, said memory subsystem storing therein a manifold pressure set point, an RPM set point, and present and prior levels for each one of said plurality of sensors;

a fuel overinjection notification circuit coupled to said processor subsystem, said fuel overinjection notification circuit issuing a notification that excessive fuel is being supplied to said engine of said vehicle;

an upshift notification circuit coupled to said processor subsystem, said upshift notification circuit issuing a notification that said engine of said vehicle is being operated at an excessive speed;

said processor subsystem determining, based upon data received from said plurality of sensors, when to activate said fuel overinjection circuit and when to activate said upshift notification circuit.

2. (Original) Apparatus for optimizing operation of a vehicle according to claim 1 wherein said processor subsystem further comprises:

means for determining when road speed for said vehicle is increasing;

means for determining when throttle position for said vehicle is increasing;

and

means for comparing manifold pressure to said manifold pressure set point;

said processor subsystem activating said fuel overinjection notification circuit if both road speed and throttle position for said vehicle are increasing and manifold pressure for said vehicle is above said manifold pressure set point.

3. (Original) Apparatus for optimizing operation of a vehicle according to claim 1 wherein said fuel overinjection circuit further comprises a horn for issuing a tone for a preselected time period.

4. (Original) Apparatus for optimizing operation of a vehicle according to claim 1 wherein said processor subsystem further comprises:

means for determining when road speed for said vehicle is decreasing;

means for determining when throttle position for said vehicle is increasing;

means for determining when manifold pressure for said vehicle is increasing;

and

means for determining when engine speed for said vehicle is decreasing;

said processor subsystem activating said fuel overinjection notification

Control No. 90013252

circuit if both throttle position and manifold pressure for said vehicle are increasing and road speed and engine speed for said vehicle are decreasing.

5. (Original) Apparatus for optimizing operation of a vehicle according to claim 1 wherein said processor subsystem further comprises:

means for determining when road speed for said vehicle is increasing;

means for determining when throttle position for said vehicle is increasing;

means for comparing manifold pressure to said manifold pressure set point;

and

means for comparing engine speed to said RPM set point;

said processor subsystem activating said upshift notification circuit if both road speed and throttle position for said vehicle are increasing, manifold pressure for said vehicle is at or below said manifold pressure set point and engine speed for said vehicle is at or above said RPM set point.

6. (Original) Apparatus for optimizing operation of a vehicle according to claim 1 wherein said upshift notification circuit further comprises a horn for issuing a tone for a preselected time period.

7. (Original) Apparatus for optimizing operation of a vehicle, comprising:

a plurality of sensors coupled to a vehicle having an engine, said plurality of sensors, which collectively monitor operation of said vehicle, including a road speed sensor, a manifold pressure sensor and a throttle position sensor;

Control No. 90013252

a processor subsystem, coupled to each one of said plurality of sensors, to receive data therefrom;

a memory subsystem, coupled to said processor subsystem, said memory subsystem storing therein a manifold pressure set point and present and prior levels for each one of said plurality of sensors;

a fuel overinjection notification circuit coupled to said processor subsystem, said fuel overinjection notification circuit issuing a notification that excessive fuel is being supplied to said engine of said vehicle;

a downshift notification circuit coupled to said processor subsystem, said downshift notification circuit issuing a notification that said engine of said vehicle is being operated at an insufficient engine speed; and

said processor subsystem determining, based upon data received from said plurality of sensors, when to activate said fuel overinjection circuit and when to activate said downshift notification circuit.

8. (Original) Apparatus for optimizing operation of a vehicle according to claim 7 wherein said processor subsystem further comprises:

means for determining when road speed for said vehicle is increasing;

means for determining when throttle position for said vehicle is increasing;

and

means for comparing manifold pressure to said manifold pressure set point;

said processor subsystem activating said fuel overinjection notification circuit if both road speed and throttle position for said vehicle are increasing and

Control No. 90013252

manifold pressure for said vehicle is above said manifold pressure set point.

9. (Original) Apparatus for optimizing operation of a vehicle according to claim 7 wherein said fuel overinjection circuit further comprises a horn for issuing a tone for a preselected time period.

10. (Original) Apparatus for optimizing operation of a vehicle according to claim 7 wherein said processor subsystem further comprises:

means for determining when road speed for said vehicle is decreasing;

means for determining when throttle position for said vehicle is increasing;

means for determining when manifold pressure for said vehicle is increasing;

and

means for determining when engine speed for said vehicle is decreasing;

said processor subsystem activating said downshift notification circuit if both road speed and engine speed are decreasing and both throttle position and manifold pressure for said vehicle are increasing.

11. (Original) Apparatus for optimizing operation of a vehicle according to claim 10 wherein said downshift notification circuit further comprises a horn for issuing a tone for a preselected time period.

12. (Original) Apparatus for optimizing operation of a vehicle according to claim 7 wherein said processor subsystem further comprises:

Control No. 90013252

means for determining when road speed for said vehicle is decreasing;

means for determining when throttle position for said vehicle is increasing;

means for determining when manifold pressure for said vehicle is increasing;

and

means for determining when engine speed for said vehicle is decreasing;

said processor subsystem activating said fuel overinjection notification circuit if both throttle position and manifold pressure for said vehicle are increasing and road speed and engine speed for said vehicle are decreasing.

13. (Original) Apparatus for optimizing operation of a vehicle, comprising:

a plurality of sensors coupled to a vehicle having an engine, said plurality of sensors, which collectively monitor operation of said vehicle, including a road speed sensor, an engine speed sensor, a manifold pressure sensor and a throttle position sensor;

a processor subsystem, coupled to each one of said plurality of sensors, to receive data therefrom;

a memory subsystem, coupled to said processor subsystem, said memory subsystem storing therein a manifold pressure set point, an engine speed set point and present and prior levels for each one of said plurality of sensors;

a fuel overinjection notification circuit coupled to said processor subsystem, said fuel overinjection notification circuit issuing a notification that excessive fuel is being supplied to said engine of said vehicle;

an upshift notification circuit coupled to said processor subsystem, said

Control No. 90013252

upshift notification circuit issuing a notification that said engine of said vehicle is being operated at an excessive engine speed;

a downshift notification circuit coupled to said processor subsystem, said downshift notification circuit issuing a notification that said engine of said vehicle is being operated at an insufficient engine speed;

said processor subsystem determining, based upon data received from said plurality of sensors, when to activate said fuel overinjection circuit, said upshift notification circuit and said downshift notification circuit.

14. (Original) Apparatus for optimizing operation of a vehicle according to claim 13 wherein:

said fuel overinjection circuit further comprises a first horn for issuing a first tone for a first preselected time period;

said upshift notification circuit further comprises a second horn for issuing a second tone for a second preselected time period; and

said downshift notification circuit further comprises a third horn for issuing a third tone for a third preselected time period.

15. (Original) Apparatus for optimizing vehicle performance according to claim 13 wherein said processor subsystem further comprises:

means for determining when road speed for said vehicle is increasing or decreasing

means for determining when throttle position for said vehicle is increasing;



Control No. 90013252

means for comparing manifold pressure to said manifold pressure set point;

means for comparing engine speed to said RPM set point;

means for determining when manifold pressure is increasing; and

means for determining when engine speed is increasing or decreasing;

said processor subsystem activating said fuel overinjection notification circuit if both road speed and throttle position for said vehicle are increasing and manifold pressure for said vehicle is above said manifold pressure set or if both throttle position and manifold pressure for said vehicle are increasing and road speed and engine speed for said vehicle are decreasing;

said processor subsystem activating said upshift notification circuit if both road speed and throttle position for said vehicle are increasing, manifold pressure for said vehicle is at or below said manifold pressure set point and engine speed for said vehicle is at or above said RPM set point; and

said processor subsystem activating said downshift notification circuit if both road speed and engine speed are decreasing and both throttle position and manifold pressure for said vehicle are increasing.

16. (Original) Apparatus for optimizing operation of a vehicle according to claim 15 wherein:

said fuel overinjection circuit further comprises a first horn for issuing a first tone for a first preselected time period;

said upshift notification circuit further comprises a second horn for issuing a second tone for a second preselected time period; and

said downshift notification circuit further comprises a third horn for issuing a third tone for a third preselected time period.

17. (Original) Apparatus for optimizing operation of a vehicle, comprising:

a radar detector, said radar detector determining a distance separating a vehicle having an engine and an object in front of said vehicle;

at least one sensor coupled to said vehicle for monitoring operation thereof, said at least one sensor including a road speed sensor, a manifold pressure sensor, a throttle position sensor and an engine speed sensor;

a processor subsystem, coupled to said radar detector and said at least one sensor, to receive data therefrom;

a memory subsystem, coupled to said processor subsystem, said memory subsystem storing a first vehicle speed/stopping distance table, a manifold pressure set point, an RPM set point, a present level for each one of said at least one sensor and a prior level for each one of said at least one sensor;

a vehicle proximity alarm circuit coupled to said processor subsystem, said vehicle proximity alarm circuit issuing an alarm that said vehicle is too close to said object;

a fuel overinjection circuit coupled to said processor subsystem, said fuel overinjection circuit issuing a notification that excessive fuel is being supplied to said engine of said vehicle;

an upshift notification circuit coupled to said processor subsystem, said upshift notification circuit issuing a notification that said engine of said vehicle is

Control No. 90013252

being operated at an excessive speed;

said processor subsystem determining, based upon data received from said radar detector, said at least one sensor and said memory subsystem, when to activate said vehicle proximity alarm circuit, when to activate said fuel overinjection circuit, and when to activate said upshift notification circuit.

18. (Original) Apparatus for optimizing operation of a vehicle according to claim 17 wherein:

said at least one sensor further includes a windshield wiper sensor for indicating whether a windshield wiper of said vehicle is activated; and

said memory subsystem further storing a second vehicle speed/stopping distance table.

19. (Original) Apparatus for optimizing operation of a vehicle according to claim 17 and further comprising:

a throttle controller for controlling a throttle of said engine of said vehicle; and

said processor subsystem selectively reducing said throttle based upon data received from said radar detector, said at least one sensor and said memory subsystem.

20. (Original) Apparatus for optimizing operation of a vehicle according to claim 19 wherein said at least one sensor further includes a brake sensor for indicating

Control No. 90013252

whether a brake system of said vehicle is activated.

21. (Original) Apparatus for optimizing operation of a vehicle according to claim 19 wherein said processor subsystem further comprises:

means for counting a total number of vehicle proximity alarms determined by said processor subsystem;

means for selectively reducing said throttle based upon said total number of vehicle proximity alarms.

22. (Original) Apparatus for optimizing operation of a vehicle according to claim 17 and further comprising:

a downshift notification circuit coupled to said processor subsystem, said downshift notification circuit issuing a notification that said engine of said vehicle is being operated at an insufficient engine speed; and

said processor subsystem determining, based upon data received from said plurality of sensors, when to activate said downshift notification circuit.

23. (Original) Apparatus for optimizing operation of a vehicle, comprising:

a radar detector, said radar detector determining a distance separating a vehicle having an engine and an object in front of said vehicle;

a plurality of sensors coupled to a vehicle having an engine, said plurality of sensors, which collectively monitor operation of said vehicle, including a road speed sensor, and engine speed sensor, a manifold pressure sensor and a throttle position

Control No. 90013252

sensor;

a processor subsystem, coupled to said radar detector and each one of said plurality of sensors, to receive data therefrom;

a memory subsystem, coupled to said processor subsystem, said memory subsystem storing therein a first vehicle speed/stopping distance table, a manifold pressure set point, an RPM set point, and present and prior levels for each one of said plurality of sensors;

a fuel overinjection notification circuit coupled to said processor subsystem, said fuel overinjection notification circuit issuing a notification that excessive fuel is being supplied to said engine of said vehicle;

an upshift notification circuit coupled to said processor subsystem, said upshift notification circuit issuing a notification that said engine of said vehicle is being operated at an excessive engine speed;

said processor subsystem determining, based upon data received from said plurality of sensors, when to activate said fuel overinjection circuit and when to activate said upshift notification circuit;

a vehicle proximity alarm circuit coupled to said processor subsystem, said vehicle proximity alarm circuit issuing an alarm that said vehicle is too close to said object;

said processor subsystem determining, based upon data received from said radar detector, said at least one sensor and said memory subsystem, when to activate said vehicle proximity alarm circuit.

Control No. 90013252

24. (Original) Apparatus for optimizing operation of a vehicle according to claim 23 wherein said processor subsystem further comprises:

means for determining when road speed for said vehicle is increasing or decreasing;

means for determining when throttle position for said vehicle is increasing or decreasing; and

means for comparing manifold pressure to said manifold pressure set point;

means for determining when manifold pressure for said vehicle is increasing or decreasing; and

means for determining when engine speed for said vehicle is increasing or decreasing;

said processor subsystem activating said fuel overinjection notification circuit if both road speed and throttle position for said vehicle are increasing and manifold pressure for said vehicle is above said manifold pressure set point or if both throttle position and manifold pressure for said vehicle are increasing and road speed and engine speed for said vehicle are decreasing.

25. (Original) Apparatus for optimizing operation of a vehicle according to claim 23 wherein said processor subsystem further comprises:

means for determining when road speed for said vehicle is increasing;

means for determining when throttle position for said vehicle is increasing;

means for comparing manifold pressure to said manifold pressure set point;

and

means for comparing engine speed to said RPM set point;

said processor subsystem activating said upshift notification circuit if both road speed and throttle position for said vehicle are increasing, manifold pressure for said vehicle is at or below said manifold pressure set point and engine speed for said vehicle is at or above said RPM set point.

26. (Original) Apparatus for optimizing operation of a vehicle, comprising:

a radar detector, said radar detector determining a distance separating a vehicle having an engine and an object in front of said vehicle;

a plurality of sensors coupled to a vehicle having an engine, said plurality of sensors, which collectively monitor operation of said vehicle, including a road speed sensor, and engine speed sensor, a manifold pressure sensor and a throttle position sensor;

a processor subsystem, coupled to said radar detector and each one of said plurality of sensors, to receive data therefrom;

a memory subsystem, coupled to said processor subsystem, said memory subsystem storing therein a first vehicle speed/stopping distance table, a manifold pressure set point, RPM set point, and present and prior levels for each one of said plurality of sensors;

a fuel overinjection notification circuit coupled to said processor subsystem, said fuel overinjection notification circuit issuing a notification that excessive fuel is being supplied to said engine of said vehicle;

a downshift notification circuit coupled to said processor subsystem, said

Control No. 90013252

downshift notification circuit issuing a notification that said engine of said vehicle is being operated at an insufficient engine speed;

said processor subsystem determining, based upon data received from said plurality of sensors, when to activate said fuel overinjection circuit and when to activate said downshift notification circuit;

a vehicle proximity alarm circuit coupled to said processor subsystem, said vehicle proximity alarm circuit issuing an alarm that said vehicle is too close to said object;

said processor subsystem determining, based upon data received from said radar detector, said at least one sensor and said memory subsystem, when to activate said vehicle proximity alarm circuit.

27. (Original) Apparatus for optimizing operation of a vehicle according to claim 26 wherein said processor subsystem further comprises:

means for determining when road speed for said vehicle is decreasing;

means for determining when throttle position for said vehicle is increasing;

means for determining when manifold pressure for said vehicle is increasing;

and

means for determining when engine speed for said vehicle is decreasing;

said processor subsystem activating said downshift notification circuit if both road speed and engine speed are decreasing and both throttle position and manifold pressure for said vehicle are increasing.



28. (Original) Apparatus for optimizing operation of a vehicle, comprising:

a plurality of sensors coupled to a vehicle having an engine, said plurality of sensors, which collectively monitor operation of said vehicle, including a road speed sensor, a manifold pressure sensor and a throttle position sensor;

a processor subsystem, coupled to each one of said plurality of sensors, to receive data therefrom;

a fuel overinjection notification circuit coupled to said processor subsystem, said fuel overinjection notification circuit issuing a notification that excessive fuel is being supplied to said engine of said vehicle;

said processor subsystem determining whether to activate said fuel overinjection notification sensor based upon data received from said road speed sensor, said throttle position sensor and said manifold pressure sensor.

29. (Original) Apparatus according to claim 28 and further comprising:

a memory subsystem, coupled to said processor subsystem, said memory subsystem maintaining a manifold pressure set point;

said processor subsystem activating said fuel overinjection notification circuit upon determining that:

(1) based upon data received from said road speed sensor, road speed of said vehicle is increasing;

(2) based upon data received from said throttle position sensor, throttle position for said vehicle is increasing; and

(3) based upon data received from said manifold pressure sensor, manifold

Control No. 90013252

pressure for said vehicle exceeds said manifold pressure set point.

30. (Original) Apparatus according to claim 28, wherein:

said plurality of sensors coupled to said vehicle further include an engine speed sensor;

said processor subsystem activating said fuel overinjection notification circuit upon determining that:

(1) based upon data received from said road speed sensor, road speed of said vehicle is decreasing;

(2) based upon data received from said throttle position sensor, throttle position for said vehicle is increasing;

(3) based upon data received from said manifold pressure sensor, manifold pressure for said vehicle is increasing; and

(4) based upon data received from said engine speed sensor, engine speed for said vehicle is decreasing.

31-32. Canceled.

33. (New) Apparatus for optimizing operation of a vehicle according to claim 1 further comprising:

means for determining a distance separating a vehicle and an object, wherein the vehicle includes an engine; and

a vehicle proximity alarm circuit coupled to said processor subsystem, wherein the vehicle proximity alarm circuit includes at least one of a visual notification and an audible notification;

wherein, upon the processor subsystem receiving the distance from said means for determining a distance and determining said distance is less than a predetermined distance, the processor subsystem activates the vehicle proximity alarm circuit.

34. (New) Apparatus for optimizing operation of a vehicle according to claim 33, further comprising:

a throttle controller for controlling a throttle of said engine of said vehicle;

wherein, upon the processor subsystem receiving the distance from said means for determining a distance and determining said distance received is less than a predetermined distance, the processor subsystem reduces said throttle.

35. (New) Apparatus for optimizing operation of a vehicle according to claim 33, further wherein the processor subsystem determines whether the brakes of the vehicle are activated.

36. (New) Apparatus for optimizing operation of a vehicle according to claim 33, wherein the vehicle proximity alarm circuit further comprises a display for displaying at least one of the speed of the object, and the distance to the object.

37. (New) Apparatus for optimizing operation of a vehicle according to claim 34, wherein the processor subsystem includes (i) an active mode wherein the processor subsystem activates an alarm and reduces the throttle based upon the distance received from said means for determining, and (ii) an inactive mode wherein the processor subsystem activates an alarm and the processor subsystem does not reduce the throttle based upon the distance received from said means for determining.

38. (New - Currently amended) Apparatus for optimizing operation of a vehicle according to claim 37, further comprising a mode select line for switching [means for mode selection] between said active mode and said inactive mode.

39. (New) Apparatus for optimizing operation of a vehicle according to claim 1, wherein said plurality of sensors is the engine speed sensor and the vehicle speed sensor.

40. (New) Apparatus for optimizing operation of a vehicle according to claim 1, wherein said notification that the engine is being operated an excessive speed comprises an automatic corrective action by the vehicle.

41. (New) Apparatus for optimizing operation of a vehicle according to claim 1, wherein said notification that the engine is being operated at an excessive speed notifies a driver that an upshift should be performed.

42. (New) Apparatus for optimizing operation of a vehicle according to claim 1, wherein said notification that excessive fuel is being supplied to said engine of said vehicle notifies a driver that the vehicle is not being operated fuel efficiently.

43. (New) Apparatus for optimizing operation of a vehicle according to claim 1, wherein said manifold pressure set point is a manifold pressure threshold value.

44. (New) Apparatus for optimizing operation of a vehicle according to claim 1, wherein said manifold pressure set point is a threshold value above which the manifold pressure should not exceed.

45. (New) Apparatus for optimizing operation of a vehicle according to claim 1, wherein said processor subsystem determines when to activate said fuel overinjection

circuit and said upshift notification circuit based upon said manifold pressure set point and said RPM set point.

46. (New) Apparatus for optimizing operation of a vehicle according to claim 1, wherein said determination to activate said fuel overinjection circuit is based on data from the road speed sensor.

47. (New) Apparatus for optimizing operation of a vehicle according to claim 1, wherein said determination to activate said fuel overinjection circuit is based on data from the manifold pressure sensor.

48. (New) Apparatus for optimizing operation of a vehicle according to claim 1, wherein said determination to activate said fuel overinjection circuit is based on data from the throttle position sensor.

49. (New) Apparatus for optimizing operation of a vehicle according to claim 1, wherein said processor subsystem is configured to automatically power on when the vehicle is started.

50. (New) Apparatus for optimizing operation of a vehicle according to claim 1, wherein said determination when to activate said fuel overinjection circuit and said determination when to activate said upshift notification circuit is based upon said present and prior levels for said plurality of sensors stored in said memory subsystem.

51. (New) Apparatus for optimizing operation of a vehicle according to claim 1, wherein said processor subsystem is configured to periodically communicate with said plurality of sensors.

52. (New) Apparatus for optimizing operation of a vehicle according to claim 1, wherein said processor subsystem is configured to retrieve data from the plurality of sensors and store the data in said memory subsystem.

53. (New) Apparatus for optimizing operation of a vehicle according to claim 17, wherein the processor subsystem includes (i) an active mode wherein the processor subsystem activates an alarm and reduces the throttle based upon a distance received from said radar detector, and (ii) an inactive mode wherein the processor subsystem activates an alarm and the processor subsystem does not reduce the throttle based upon a distance received from said radar detector.

54. (New – Currently Amended) Apparatus for optimizing operation of a vehicle according to claim 53, further comprising a mode select line for switching [means for mode selection] between said active mode and said inactive mode.

55. (New) Apparatus for optimizing operation of a vehicle according to claim 17, wherein said processor subsystem activates said upshift notification circuit based on the manifold pressure set point and RPM set point.

56. (New) Apparatus for optimizing operation of a vehicle according to claim 17, wherein said at least one sensor is the road speed sensor.

57. (New) Apparatus for optimizing operation of a vehicle according to claim 17, wherein the first speed/stopping distance table is based on National Safety Council guidelines.

58. (New) Apparatus for optimizing operation of a vehicle according to claim 17, further wherein said processor subsystem automatically applies the brakes based

Control No. 90013252

upon data received from said radar detector, said at least one sensor and said memory subsystem.

59. (New) Apparatus for optimizing operation of a vehicle according to claim 28 further comprising:

a means for determining a distance separating a vehicle and an object, wherein the vehicle includes an engine; and

a vehicle proximity alarm circuit coupled to said processor subsystem;

wherein said processor subsystem activates said vehicle proximity alarm circuit based at least upon the data received from said road speed sensor, and the means for determining the distance separating the vehicle and the object.

60-84. (Canceled)

85. (New - Amended Once) Apparatus for optimizing operation of a vehicle, comprising:

a radar detector, said radar detector determining a distance separating a vehicle having an engine and an object in front of said vehicle;

a plurality of sensors coupled to said vehicle for monitoring operation thereof, said plurality of sensors including a road speed sensor and an engine speed sensor;

a processor subsystem, coupled to said radar detector and said at least one sensor, to receive data therefrom;

a memory subsystem, coupled to said processor subsystem, said memory subsystem storing a first vehicle speed/stopping distance table;

a vehicle proximity alarm circuit coupled to said processor subsystem, said

Control No. 90013252

vehicle proximity alarm circuit issuing an alarm that said vehicle is too close to said object;

said processor subsystem determining whether to activate said vehicle proximity alarm circuit based upon separation distance data received from said radar detector, vehicle speed data received from said road speed sensor and said first vehicle speed/stopping distance table stored in said memory subsystem; and

a throttle controller for controlling a throttle of said engine of said vehicle;

wherein said processor subsystem selectively reduces said throttle based upon the data received from said radar detector;

further wherein the processor subsystem includes (i) an active mode in which the processor subsystem activates the vehicle proximity alarm circuit to issue the vehicle proximity alarm and reduces the throttle based upon the data received from said radar detector, and (ii) an inactive mode in which the processor subsystem activates the vehicle proximity alarm circuit to issue the alarm and the throttle is not selectively reduced based upon the data received from said radar detector;

a fuel overinjection notification circuit coupled to said processor subsystem, said fuel overinjection notification circuit issuing a notification that excessive fuel is being supplied to said engine of said vehicle;

wherein said processor subsystem determines whether to activate said fuel overinjection notification circuit based upon at least the data received from said road speed sensor.

86. (New – Amended Once) Apparatus for optimizing operation of a vehicle,



Control No. 90013252

comprising:

\_\_\_\_\_ a tachometer;

a radar detector, said radar detector determining a distance separating a vehicle having an engine and an object in front of said vehicle;

a plurality of sensors coupled to said vehicle for monitoring operation thereof, said plurality of sensors including a road speed sensor, an engine speed sensor and a brake sensor;

a processor subsystem, coupled to said radar detector and said at least one sensor, to receive data therefrom;

a memory subsystem including random access memory, coupled to said processor subsystem, said memory subsystem storing a first vehicle speed/stopping distance table;

a vehicle proximity alarm circuit coupled to said processor subsystem, said vehicle proximity alarm circuit issuing an alarm that said vehicle is too close to said object;

said processor subsystem determining whether to activate said vehicle proximity alarm circuit based upon separation distance data received from said radar detector, vehicle speed data received from said road speed sensor and said first vehicle speed/stopping distance table stored in said memory subsystem;

a throttle controller for controlling a throttle of said engine of said vehicle;

wherein said processor subsystem selectively reduces said throttle based upon the data received from said radar detector;

further wherein the processor subsystem includes (i) an active mode in

Control No. 90013252

which the processor subsystem activates the vehicle proximity alarm circuit to issue the vehicle proximity alarm and reduces the throttle based upon the data received from said radar detector, and (ii) an inactive mode in which the processor subsystem activates the vehicle proximity alarm circuit to issue the alarm and the throttle is not selectively reduced based upon the data received from said radar detector;

an upshift notification circuit coupled to said processor subsystem.

87. (New – Amended Once) Apparatus for optimizing operation of a vehicle, comprising:

a radar detector, said radar detector determining a distance separating a vehicle having an engine and an object in front of said vehicle;

a plurality of sensors coupled to said vehicle for monitoring operation thereof, said plurality of sensors including a road speed sensor, an engine speed sensor and a brake sensor;

a processor subsystem, coupled to said radar detector and said at least one sensor, to receive data therefrom;

a memory subsystem, coupled to said processor subsystem, said memory subsystem storing a first vehicle speed/stopping distance table and an RPM set point;

a vehicle proximity alarm circuit coupled to said processor subsystem, said vehicle proximity alarm circuit issuing an alarm that said vehicle is too close to said object;

Control No. 90013252

said processor subsystem determining whether to activate said vehicle proximity alarm circuit based upon separation distance data received from said radar detector, vehicle speed data received from said road speed sensor and said first vehicle speed/stopping distance table stored in said memory subsystem;

a throttle controller for controlling a throttle of said engine of said vehicle;

wherein said processor subsystem selectively reduces said throttle based upon the data received from said radar detector;

further wherein the processor subsystem includes (i) an active mode in which the processor subsystem activates the vehicle proximity alarm circuit to issue the vehicle proximity alarm and reduces the throttle based upon the data received from said radar detector, and (ii) an inactive mode in which the processor subsystem activates the vehicle proximity alarm circuit to issue the alarm and the throttle is not selectively reduced based upon the data received from said radar detector;

further wherein said processor subsystem determines whether a brake of the vehicle is activated based upon data received from the brake sensor.

88. (New – Currently Amended) Apparatus for optimizing operation of a vehicle according to claim 87, further comprising a mode select line for switching [means for mode selection] between said active mode and said inactive mode.

89. (New) Apparatus for optimizing operation of a vehicle according to claim 88, further comprising an upshift notification circuit coupled to said processor subsystem, said upshift notification circuit issuing a notification that said engine of

said vehicle is being operated at an excessive speed.

90. (New) Apparatus for optimizing operation of a vehicle according to claim 89, further comprising a downshift notification circuit coupled to said processor subsystem, said downshift notification circuit issuing a notification that said engine of said vehicle is being operated at an insufficient engine speed.

91. (New) Apparatus for optimizing operation of a vehicle according to claim 88, further comprising a selector for selecting a type of vehicle proximity alarm, wherein the type of vehicle proximity alarm is selected from the group consisting of an audible indication, a visual indication, and combinations thereof.

92. (New) Apparatus for optimizing operation of a vehicle according to claim 85, wherein said first speed/stopping distance table is a lookup table.

93. (New) Apparatus for optimizing operation of a vehicle according to claim 85, wherein said first speed/stopping distance table is based upon National Safety Council guidelines.

94. (New) Apparatus for optimizing operation of a vehicle according to claim 88, further comprising a bus for bidirectional exchanges of address, data and control signals between said processor subsystem and said memory subsystem.

95. (New) Apparatus for optimizing operation of a vehicle according to claim 94, wherein said memory subsystem includes at least one register for holding the level of said road speed sensor.

96. (New) Apparatus for optimizing operation of a vehicle according to claim 88, further comprising a speedometer.

97. (New) Apparatus for optimizing operation of a vehicle according to

claim 85, wherein said vehicle comprises a truck.

98. (New) Apparatus for optimizing operation of a vehicle according to claim 88, further comprising a power source including voltage divider circuitry.

99. (New) Apparatus for optimizing operation of a vehicle according to claim 85, wherein said memory subsystem stores vehicle class information.

100. (New) Apparatus for optimizing operation of a vehicle according to claim 85, wherein said processor subsystem is configured to automatically power on when the vehicle is started.

101. (New) Apparatus for optimizing operation of a vehicle according to claim 88, wherein said processor subsystem is configured to retrieve data from said road speed sensor and store the data in said memory subsystem.

102. (New) Apparatus for optimizing operation of a vehicle according to claim 88, wherein said processor subsystem is configured to wait a preselected time period after issuing the vehicle proximity alarm.

103. (New) Apparatus for optimizing operation of a vehicle according to claim 88, wherein said processor subsystem is configured to select a type of vehicle proximity alarm based on the determined distance, wherein the type of vehicle proximity alarm is selected from the group consisting of an audible indication, a visual indication, and combinations thereof.

104. (New) Apparatus for optimizing operation of a vehicle according to claim 85, wherein said first speed/stopping distance table is the relationship between vehicle speed and stopping distance.

105. (New) Apparatus for optimizing operation of a vehicle according to

Control No. 90013252

claim 85 wherein:

said plurality of sensors further including a windshield wiper sensor for indicating whether a windshield wiper of said vehicle is activated; and

said memory subsystem further storing a second vehicle speed/stopping distance table;

if said windshield wiper sensor indicates that said windshield wiper is deactivated, said processor subsystem determining whether to activate said vehicle proximity alarm circuit based upon data received from said radar detector, said road speed sensor and said first vehicle speed/stopping distance table stored in said memory subsystem;

if said windshield wiper sensor indicates that said windshield wiper is activated, said processor subsystem determining whether to activate said vehicle proximity alarm circuit based upon data received from said radar detector, said road speed sensor and said second vehicle speed/stopping distance table stored in said memory subsystem.

106. (New - Currently Amended) Apparatus for optimizing operation of a vehicle according to claim 86, further comprising a mode select line for switching [means for mode selection] between said active mode and said inactive mode.

107. (New) Apparatus for optimizing operation of a vehicle according to claim 106, further comprising:

a display;

wherein the vehicle proximity alarm includes at least one of an audible and a visual indication; and

wherein the visual indication is displayed on the display.

108. (New) Apparatus for optimizing operation of a vehicle according to claim 107, further comprising a selector for selecting a type of vehicle proximity alarm, wherein the type of vehicle proximity alarm is selected from the group consisting of an audible indication, a visual indication, and combinations thereof.

109. (New) Apparatus for optimizing operation of a vehicle according to claim 86, wherein said processor subsystem tracks the number of vehicle proximity alarms issued before corrective action eliminates a hazardous condition.

110. (New) Apparatus for optimizing operation of a vehicle according to claim 108, wherein said memory subsystem stores vehicle class information.

111. (New) Apparatus for optimizing operation of a vehicle according to claim 108, wherein said processor subsystem is configured to select a type of vehicle proximity alarm based on the determined distance, wherein the type of vehicle proximity alarm is selected from the group consisting of an audible indication, a visual indication, and combinations thereof.

112. (New) Apparatus for optimizing operation of a vehicle according to claim 111, further comprising a fuel overinjection notification circuit coupled to said processor subsystem, said fuel overinjection notification circuit issuing a notification that excessive fuel is being supplied to said engine of said vehicle.

113. (New) Apparatus for optimizing operation of a vehicle according to claim 87, further comprising:

an upshift notification circuit coupled to said processor subsystem, said upshift notification circuit issuing a notification that said engine of said vehicle is being operated at an excessive speed; and  
said processor subsystem determining, based upon whether engine speed exceeds said RPM set point, when to activate said upshift notification circuit.

114. (New) Apparatus for optimizing operation of a vehicle according to claim 87, further comprising a selector for selecting a type of vehicle proximity alarm, wherein the type of vehicle proximity alarm is selected from the group consisting of an audible indication, a visual indication, and combinations thereof.

115. (New) Apparatus for optimizing operation of a vehicle according to claim 85, further comprising:

a display;

wherein the vehicle proximity alarm includes at least one of an audible and a visual indication; and

wherein the visual indication is displayed on the display.



**Remarks**

This Amendment is being submitted to in response to the Examiner's Interview on March 11, 2015. The interview addressed the following:

- All of the new claims must be underlined and the indicator must communicate "New - Amended Once" if the claim has been amended since it was presented;
- Claim 60 was missing from the canceled claims 61-84;
- Claims 38, 54, 88, and 106 invoke 35 U.S.C. 112(6), however, the specification does not support such language. The Examiner suggested amending the claims to remove the "means for" language and replace with the disclosed "mode select line."

In response to the interview, Applicants have re-underlined all of the new claims and corrected the indicators to indicate if the claim has been amended since it was presented. In addition, claim 60 has been indicated as canceled. Lastly, claims 38, 54, 88, and 106 have been amended to remove the "means for" language and explicitly claim the "mode select line" as supported in the specification at col. 7, lines 47-58.

**Conclusion**

In view of the foregoing remarks, Patent Owner submits that all of the currently pending claims are in allowable form and that the application is in condition for allowance. Therefore, Patent Owner respectfully requests that a timely Reexamination Certificate confirming the present claims be issued in this case. If for any reason the Examiner is unable to issue a Reexamination Certificate confirming the present claims the application and feels that an interview would be helpful to resolve any remaining issues, the Examiner is requested to contact the undersigned attorney at (312) 283-8555.

Respectfully submitted,

RICHARDS PATENT LAW PC



Patrick D. Richards  
Registration. No. 48,905

**Please recognize Customer No. 88360  
as the correspondence address.**

Richards Patent Law P.C.  
233 S. Wacker Dr., 84<sup>th</sup> Floor  
Chicago, IL 60606  
Phone: (312) 283-8555  
**Date: March 12, 2015**

## Electronic Acknowledgement Receipt

<b>EFS ID:</b>	21747834
<b>Application Number:</b>	90013252
<b>International Application Number:</b>	
<b>Confirmation Number:</b>	9999
<b>Title of Invention:</b>	Method and Apparatus for Optimizing Vehicle Operation
<b>First Named Inventor/Applicant Name:</b>	5,954,781
<b>Customer Number:</b>	88360
<b>Filer:</b>	Patrick Duffy Richards
<b>Filer Authorized By:</b>	
<b>Attorney Docket Number:</b>	
<b>Receipt Date:</b>	12-MAR-2015
<b>Filing Date:</b>	22-MAY-2014
<b>Time Stamp:</b>	12:08:56
<b>Application Type:</b>	Reexam (Third Party)

### Payment information:

Submitted with Payment	no
------------------------	----

### File Listing:

Document Number	Document Description	File Name	File Size(Bytes)/ Message Digest	Multi Part /.zip	Pages (if appl.)
1	Amendment/Req. Reconsideration-After Non-Final Reject	1089-001Amendment.pdf	215003 <small>256ae89ee8d1be1619dcb80458cef82ecd16b834</small>	no	34

### Warnings:

### Information:

This Acknowledgement Receipt evidences receipt on the noted date by the USPTO of the indicated documents, characterized by the applicant, and including page counts, where applicable. It serves as evidence of receipt similar to a Post Card, as described in MPEP 503.

**New Applications Under 35 U.S.C. 111**

If a new application is being filed and the application includes the necessary components for a filing date (see 37 CFR 1.53(b)-(d) and MPEP 506), a Filing Receipt (37 CFR 1.54) will be issued in due course and the date shown on this Acknowledgement Receipt will establish the filing date of the application.

**National Stage of an International Application under 35 U.S.C. 371**

If a timely submission to enter the national stage of an international application is compliant with the conditions of 35 U.S.C. 371 and other applicable requirements a Form PCT/DO/EO/903 indicating acceptance of the application as a national stage submission under 35 U.S.C. 371 will be issued in addition to the Filing Receipt, in due course.

**New International Application Filed with the USPTO as a Receiving Office**

If a new international application is being filed and the international application includes the necessary components for an international filing date (see PCT Article 11 and MPEP 1810), a Notification of the International Application Number and of the International Filing Date (Form PCT/RO/105) will be issued in due course, subject to prescriptions concerning national security, and the date shown on this Acknowledgement Receipt will establish the international filing date of the application.

Docket No. 1089-001

**PATENT**

**IN THE UNITED STATES PATENT AND TRADEMARK OFFICE**

**Control No.** : 90013252                      **Confirmation No.** : 9999  
**Patent No.** : 5,954,781  
**Applicant** : Harvey Slepian  
**Reexam Filed:** May 22, 2014  
**Art Unit.** : 3992  
**Examiner** : David E. England  
**Customer No.:** 88360

Commissioner for Patents  
P.O. Box 1450  
Alexandria, VA 22313-1450

**RESPONSE**

Sir:

This Supplemental Response is being submitted in the above-identified Reexamination. Please amend the above-identified application as follows:

**Amendments to the Claims** are reflected in the listing of claims, which begins on page 2 of this paper.

**Remarks/Arguments** begin on page 34 of this paper.

### **Amendments to the Claims**

This listing of claims will replace all prior versions, and listings, of claims in the application:

#### **Listing of Claims**

1. (Original) Apparatus for optimizing operation of a vehicle, comprising:

a plurality of sensors coupled to a vehicle having an engine, said plurality of sensors, which collectively monitor operation of said vehicle, including a road speed sensor, an engine speed sensor, a manifold pressure sensor and a throttle position sensor;

a processor subsystem, coupled to each one of said plurality of sensors, to receive data therefrom;

a memory subsystem, coupled to said processor subsystem, said memory subsystem storing therein a manifold pressure set point, an RPM set point, and present and prior levels for each one of said plurality of sensors;

a fuel overinjection notification circuit coupled to said processor subsystem, said fuel overinjection notification circuit issuing a notification that excessive fuel is being supplied to said engine of said vehicle;

an upshift notification circuit coupled to said processor subsystem, said upshift notification circuit issuing a notification that said engine of said vehicle is being operated at an excessive speed;

said processor subsystem determining, based upon data received from said plurality of sensors, when to activate said fuel overinjection circuit and when to activate said upshift notification circuit.

2. (Original) Apparatus for optimizing operation of a vehicle according to claim 1 wherein said processor subsystem further comprises:

means for determining when road speed for said vehicle is increasing;

means for determining when throttle position for said vehicle is increasing;

and

means for comparing manifold pressure to said manifold pressure set point;

said processor subsystem activating said fuel overinjection notification circuit if both road speed and throttle position for said vehicle are increasing and manifold pressure for said vehicle is above said manifold pressure set point.

3. (Original) Apparatus for optimizing operation of a vehicle according to claim 1 wherein said fuel overinjection circuit further comprises a horn for issuing a tone for a preselected time period.

4. (Original) Apparatus for optimizing operation of a vehicle according to claim 1 wherein said processor subsystem further comprises:

means for determining when road speed for said vehicle is decreasing;

means for determining when throttle position for said vehicle is increasing;

means for determining when manifold pressure for said vehicle is increasing;

and

means for determining when engine speed for said vehicle is decreasing;

said processor subsystem activating said fuel overinjection notification

Control No. 90013252

circuit if both throttle position and manifold pressure for said vehicle are increasing and road speed and engine speed for said vehicle are decreasing.

5. (Original) Apparatus for optimizing operation of a vehicle according to claim 1 wherein said processor subsystem further comprises:

means for determining when road speed for said vehicle is increasing;

means for determining when throttle position for said vehicle is increasing;

means for comparing manifold pressure to said manifold pressure set point;

and

means for comparing engine speed to said RPM set point;

said processor subsystem activating said upshift notification circuit if both road speed and throttle position for said vehicle are increasing, manifold pressure for said vehicle is at or below said manifold pressure set point and engine speed for said vehicle is at or above said RPM set point.

6. (Original) Apparatus for optimizing operation of a vehicle according to claim 1 wherein said upshift notification circuit further comprises a horn for issuing a tone for a preselected time period.

7. (Original) Apparatus for optimizing operation of a vehicle, comprising:

a plurality of sensors coupled to a vehicle having an engine, said plurality of sensors, which collectively monitor operation of said vehicle, including a road speed sensor, a manifold pressure sensor and a throttle position sensor;



Control No. 90013252

a processor subsystem, coupled to each one of said plurality of sensors, to receive data therefrom;

a memory subsystem, coupled to said processor subsystem, said memory subsystem storing therein a manifold pressure set point and present and prior levels for each one of said plurality of sensors;

a fuel overinjection notification circuit coupled to said processor subsystem, said fuel overinjection notification circuit issuing a notification that excessive fuel is being supplied to said engine of said vehicle;

a downshift notification circuit coupled to said processor subsystem, said downshift notification circuit issuing a notification that said engine of said vehicle is being operated at an insufficient engine speed; and

said processor subsystem determining, based upon data received from said plurality of sensors, when to activate said fuel overinjection circuit and when to activate said downshift notification circuit.

8. (Original) Apparatus for optimizing operation of a vehicle according to claim 7 wherein said processor subsystem further comprises:

means for determining when road speed for said vehicle is increasing;

means for determining when throttle position for said vehicle is increasing;

and

means for comparing manifold pressure to said manifold pressure set point;

said processor subsystem activating said fuel overinjection notification circuit if both road speed and throttle position for said vehicle are increasing and

Control No. 90013252

manifold pressure for said vehicle is above said manifold pressure set point.

9. (Original) Apparatus for optimizing operation of a vehicle according to claim 7 wherein said fuel overinjection circuit further comprises a horn for issuing a tone for a preselected time period.

10. (Original) Apparatus for optimizing operation of a vehicle according to claim 7 wherein said processor subsystem further comprises:

means for determining when road speed for said vehicle is decreasing;

means for determining when throttle position for said vehicle is increasing;

means for determining when manifold pressure for said vehicle is increasing;

and

means for determining when engine speed for said vehicle is decreasing;

said processor subsystem activating said downshift notification circuit if both road speed and engine speed are decreasing and both throttle position and manifold pressure for said vehicle are increasing.

11. (Original) Apparatus for optimizing operation of a vehicle according to claim 10 wherein said downshift notification circuit further comprises a horn for issuing a tone for a preselected time period.

12. (Original) Apparatus for optimizing operation of a vehicle according to claim 7 wherein said processor subsystem further comprises:

Control No. 90013252

means for determining when road speed for said vehicle is decreasing;

means for determining when throttle position for said vehicle is increasing;

means for determining when manifold pressure for said vehicle is increasing;

and

means for determining when engine speed for said vehicle is decreasing;

said processor subsystem activating said fuel overinjection notification circuit if both throttle position and manifold pressure for said vehicle are increasing and road speed and engine speed for said vehicle are decreasing.

13. (Original) Apparatus for optimizing operation of a vehicle, comprising:

a plurality of sensors coupled to a vehicle having an engine, said plurality of sensors, which collectively monitor operation of said vehicle, including a road speed sensor, an engine speed sensor, a manifold pressure sensor and a throttle position sensor;

a processor subsystem, coupled to each one of said plurality of sensors, to receive data therefrom;

a memory subsystem, coupled to said processor subsystem, said memory subsystem storing therein a manifold pressure set point, an engine speed set point and present and prior levels for each one of said plurality of sensors;

a fuel overinjection notification circuit coupled to said processor subsystem, said fuel overinjection notification circuit issuing a notification that excessive fuel is being supplied to said engine of said vehicle;

an upshift notification circuit coupled to said processor subsystem, said

Control No. 90013252

upshift notification circuit issuing a notification that said engine of said vehicle is being operated at an excessive engine speed;

a downshift notification circuit coupled to said processor subsystem, said downshift notification circuit issuing a notification that said engine of said vehicle is being operated at an insufficient engine speed;

said processor subsystem determining, based upon data received from said plurality of sensors, when to activate said fuel overinjection circuit, said upshift notification circuit and said downshift notification circuit.

14. (Original) Apparatus for optimizing operation of a vehicle according to claim 13 wherein:

said fuel overinjection circuit further comprises a first horn for issuing a first tone for a first preselected time period;

said upshift notification circuit further comprises a second horn for issuing a second tone for a second preselected time period; and

said downshift notification circuit further comprises a third horn for issuing a third tone for a third preselected time period.

15. (Original) Apparatus for optimizing vehicle performance according to claim 13 wherein said processor subsystem further comprises:

means for determining when road speed for said vehicle is increasing or decreasing

means for determining when throttle position for said vehicle is increasing;

Control No. 90013252

means for comparing manifold pressure to said manifold pressure set point;

means for comparing engine speed to said RPM set point;

means for determining when manifold pressure is increasing; and

means for determining when engine speed is increasing or decreasing;

said processor subsystem activating said fuel overinjection notification circuit if both road speed and throttle position for said vehicle are increasing and manifold pressure for said vehicle is above said manifold pressure set or if both throttle position and manifold pressure for said vehicle are increasing and road speed and engine speed for said vehicle are decreasing;

said processor subsystem activating said upshift notification circuit if both road speed and throttle position for said vehicle are increasing, manifold pressure for said vehicle is at or below said manifold pressure set point and engine speed for said vehicle is at or above said RPM set point; and

said processor subsystem activating said downshift notification circuit if both road speed and engine speed are decreasing and both throttle position and manifold pressure for said vehicle are increasing.

16. (Original) Apparatus for optimizing operation of a vehicle according to claim 15 wherein:

said fuel overinjection circuit further comprises a first horn for issuing a first tone for a first preselected time period;

said upshift notification circuit further comprises a second horn for issuing a second tone for a second preselected time period; and

said downshift notification circuit further comprises a third horn for issuing a third tone for a third preselected time period.

17. (Original) Apparatus for optimizing operation of a vehicle, comprising:

a radar detector, said radar detector determining a distance separating a vehicle having an engine and an object in front of said vehicle;

at least one sensor coupled to said vehicle for monitoring operation thereof, said at least one sensor including a road speed sensor, a manifold pressure sensor, a throttle position sensor and an engine speed sensor;

a processor subsystem, coupled to said radar detector and said at least one sensor, to receive data therefrom;

a memory subsystem, coupled to said processor subsystem, said memory subsystem storing a first vehicle speed/stopping distance table, a manifold pressure set point, an RPM set point, a present level for each one of said at least one sensor and a prior level for each one of said at least one sensor;

a vehicle proximity alarm circuit coupled to said processor subsystem, said vehicle proximity alarm circuit issuing an alarm that said vehicle is too close to said object;

a fuel overinjection circuit coupled to said processor subsystem, said fuel overinjection circuit issuing a notification that excessive fuel is being supplied to said engine of said vehicle;

an upshift notification circuit coupled to said processor subsystem, said upshift notification circuit issuing a notification that said engine of said vehicle is

Control No. 90013252

being operated at an excessive speed;

said processor subsystem determining, based upon data received from said radar detector, said at least one sensor and said memory subsystem, when to activate said vehicle proximity alarm circuit, when to activate said fuel overinjection circuit, and when to activate said upshift notification circuit.

18. (Original) Apparatus for optimizing operation of a vehicle according to claim 17 wherein:

said at least one sensor further includes a windshield wiper sensor for indicating whether a windshield wiper of said vehicle is activated; and

said memory subsystem further storing a second vehicle speed/stopping distance table.

19. (Original) Apparatus for optimizing operation of a vehicle according to claim 17 and further comprising:

a throttle controller for controlling a throttle of said engine of said vehicle; and

said processor subsystem selectively reducing said throttle based upon data received from said radar detector, said at least one sensor and said memory subsystem.

20. (Original) Apparatus for optimizing operation of a vehicle according to claim 19 wherein said at least one sensor further includes a brake sensor for indicating

Control No. 90013252

whether a brake system of said vehicle is activated.

21. (Original) Apparatus for optimizing operation of a vehicle according to claim 19 wherein said processor subsystem further comprises:

means for counting a total number of vehicle proximity alarms determined by said processor subsystem;

means for selectively reducing said throttle based upon said total number of vehicle proximity alarms.

22. (Original) Apparatus for optimizing operation of a vehicle according to claim 17 and further comprising:

a downshift notification circuit coupled to said processor subsystem, said downshift notification circuit issuing a notification that said engine of said vehicle is being operated at an insufficient engine speed; and

said processor subsystem determining, based upon data received from said plurality of sensors, when to activate said downshift notification circuit.

23. (Original) Apparatus for optimizing operation of a vehicle, comprising:

a radar detector, said radar detector determining a distance separating a vehicle having an engine and an object in front of said vehicle;

a plurality of sensors coupled to a vehicle having an engine, said plurality of sensors, which collectively monitor operation of said vehicle, including a road speed sensor, and engine speed sensor, a manifold pressure sensor and a throttle position



Control No. 90013252

sensor;

a processor subsystem, coupled to said radar detector and each one of said plurality of sensors, to receive data therefrom;

a memory subsystem, coupled to said processor subsystem, said memory subsystem storing therein a first vehicle speed/stopping distance table, a manifold pressure set point, an RPM set point, and present and prior levels for each one of said plurality of sensors;

a fuel overinjection notification circuit coupled to said processor subsystem, said fuel overinjection notification circuit issuing a notification that excessive fuel is being supplied to said engine of said vehicle;

an upshift notification circuit coupled to said processor subsystem, said upshift notification circuit issuing a notification that said engine of said vehicle is being operated at an excessive engine speed;

said processor subsystem determining, based upon data received from said plurality of sensors, when to activate said fuel overinjection circuit and when to activate said upshift notification circuit;

a vehicle proximity alarm circuit coupled to said processor subsystem, said vehicle proximity alarm circuit issuing an alarm that said vehicle is too close to said object;

said processor subsystem determining, based upon data received from said radar detector, said at least one sensor and said memory subsystem, when to activate said vehicle proximity alarm circuit.

Control No. 90013252

24. (Original) Apparatus for optimizing operation of a vehicle according to claim 23 wherein said processor subsystem further comprises:

means for determining when road speed for said vehicle is increasing or decreasing;

means for determining when throttle position for said vehicle is increasing or decreasing; and

means for comparing manifold pressure to said manifold pressure set point;

means for determining when manifold pressure for said vehicle is increasing or decreasing; and

means for determining when engine speed for said vehicle is increasing or decreasing;

said processor subsystem activating said fuel overinjection notification circuit if both road speed and throttle position for said vehicle are increasing and manifold pressure for said vehicle is above said manifold pressure set point or if both throttle position and manifold pressure for said vehicle are increasing and road speed and engine speed for said vehicle are decreasing.

25. (Original) Apparatus for optimizing operation of a vehicle according to claim 23 wherein said processor subsystem further comprises:

means for determining when road speed for said vehicle is increasing;

means for determining when throttle position for said vehicle is increasing;

means for comparing manifold pressure to said manifold pressure set point;

and

means for comparing engine speed to said RPM set point;

said processor subsystem activating said upshift notification circuit if both road speed and throttle position for said vehicle are increasing, manifold pressure for said vehicle is at or below said manifold pressure set point and engine speed for said vehicle is at or above said RPM set point.

26. (Original) Apparatus for optimizing operation of a vehicle, comprising:

a radar detector, said radar detector determining a distance separating a vehicle having an engine and an object in front of said vehicle;

a plurality of sensors coupled to a vehicle having an engine, said plurality of sensors, which collectively monitor operation of said vehicle, including a road speed sensor, and engine speed sensor, a manifold pressure sensor and a throttle position sensor;

a processor subsystem, coupled to said radar detector and each one of said plurality of sensors, to receive data therefrom;

a memory subsystem, coupled to said processor subsystem, said memory subsystem storing therein a first vehicle speed/stopping distance table, a manifold pressure set point, RPM set point, and present and prior levels for each one of said plurality of sensors;

a fuel overinjection notification circuit coupled to said processor subsystem, said fuel overinjection notification circuit issuing a notification that excessive fuel is being supplied to said engine of said vehicle;

a downshift notification circuit coupled to said processor subsystem, said

Control No. 90013252

downshift notification circuit issuing a notification that said engine of said vehicle is being operated at an insufficient engine speed;

said processor subsystem determining, based upon data received from said plurality of sensors, when to activate said fuel overinjection circuit and when to activate said downshift notification circuit;

a vehicle proximity alarm circuit coupled to said processor subsystem, said vehicle proximity alarm circuit issuing an alarm that said vehicle is too close to said object;

said processor subsystem determining, based upon data received from said radar detector, said at least one sensor and said memory subsystem, when to activate said vehicle proximity alarm circuit.

27. (Original) Apparatus for optimizing operation of a vehicle according to claim 26 wherein said processor subsystem further comprises:

means for determining when road speed for said vehicle is decreasing;

means for determining when throttle position for said vehicle is increasing;

means for determining when manifold pressure for said vehicle is increasing;

and

means for determining when engine speed for said vehicle is decreasing;

said processor subsystem activating said downshift notification circuit if both road speed and engine speed are decreasing and both throttle position and manifold pressure for said vehicle are increasing.

28. (Original) Apparatus for optimizing operation of a vehicle, comprising:

a plurality of sensors coupled to a vehicle having an engine, said plurality of sensors, which collectively monitor operation of said vehicle, including a road speed sensor, a manifold pressure sensor and a throttle position sensor;

a processor subsystem, coupled to each one of said plurality of sensors, to receive data therefrom;

a fuel overinjection notification circuit coupled to said processor subsystem, said fuel overinjection notification circuit issuing a notification that excessive fuel is being supplied to said engine of said vehicle;

said processor subsystem determining whether to activate said fuel overinjection notification sensor based upon data received from said road speed sensor, said throttle position sensor and said manifold pressure sensor.

29. (Original) Apparatus according to claim 28 and further comprising:

a memory subsystem, coupled to said processor subsystem, said memory subsystem maintaining a manifold pressure set point;

said processor subsystem activating said fuel overinjection notification circuit upon determining that:

(1) based upon data received from said road speed sensor, road speed of said vehicle is increasing;

(2) based upon data received from said throttle position sensor, throttle position for said vehicle is increasing; and

(3) based upon data received from said manifold pressure sensor, manifold

Control No. 90013252

pressure for said vehicle exceeds said manifold pressure set point.

30. (Original) Apparatus according to claim 28, wherein:

said plurality of sensors coupled to said vehicle further include an engine speed sensor;

said processor subsystem activating said fuel overinjection notification circuit upon determining that:

(1) based upon data received from said road speed sensor, road speed of said vehicle is decreasing;

(2) based upon data received from said throttle position sensor, throttle position for said vehicle is increasing;

(3) based upon data received from said manifold pressure sensor, manifold pressure for said vehicle is increasing; and

(4) based upon data received from said engine speed sensor, engine speed for said vehicle is decreasing.

31-32. Canceled.

33. (Previously Presented) Apparatus for optimizing operation of a vehicle according to claim 1 further comprising:

means for determining a distance separating a vehicle and an object, wherein the vehicle includes an engine; and

a vehicle proximity alarm circuit coupled to said processor subsystem, wherein the vehicle proximity alarm circuit includes at least one of a visual notification and an audible notification;

wherein, upon the processor subsystem receiving the distance from said means for determining a distance and determining said distance is less than a predetermined distance, the processor subsystem activates the vehicle proximity alarm circuit.

34. (Previously Presented) Apparatus for optimizing operation of a vehicle according to claim 33, further comprising:

a throttle controller for controlling a throttle of said engine of said vehicle;

wherein, upon the processor subsystem receiving the distance from said means for determining a distance and determining said distance received is less than a predetermined distance, the processor subsystem reduces said throttle.

35. (Previously Presented) Apparatus for optimizing operation of a vehicle according to claim 33, further wherein the processor subsystem determines whether the brakes of the vehicle are activated.

36. (Previously Presented) Apparatus for optimizing operation of a vehicle according to claim 33, wherein the vehicle proximity alarm circuit further comprises a display for displaying at least one of the speed of the object, and the distance to the object.

37. (Previously Presented) Apparatus for optimizing operation of a vehicle according to claim 34, wherein the processor subsystem includes (i) an active mode wherein the processor subsystem activates an alarm and reduces the throttle based upon the distance received from said means for determining, and (ii) an inactive mode wherein the processor subsystem activates an alarm and the processor

Control No. 90013252

subsystem does not reduce the throttle based upon the distance received from said means for determining.

38. (Previously Presented) Apparatus for optimizing operation of a vehicle according to claim 37, further comprising a means for mode selection between said active mode and said inactive mode.

39. (Previously Presented) Apparatus for optimizing operation of a vehicle according to claim 1, wherein said plurality of sensors is the engine speed sensor and the vehicle speed sensor.

40. (Previously Presented) Apparatus for optimizing operation of a vehicle according to claim 1, wherein said notification that the engine is being operated an excessive speed comprises an automatic corrective action by the vehicle.

41. (Previously Presented) Apparatus for optimizing operation of a vehicle according to claim 1, wherein said notification that the engine is being operated at an excessive speed notifies a driver that an upshift should be performed.

42. (Previously Presented) Apparatus for optimizing operation of a vehicle according to claim 1, wherein said notification that excessive fuel is being supplied to said engine of said vehicle notifies a driver that the vehicle is not being operated fuel efficiently.

43. (Previously Presented) Apparatus for optimizing operation of a vehicle according to claim 1, wherein said manifold pressure set point is a manifold pressure threshold value.



44. (Previously Presented) Apparatus for optimizing operation of a vehicle according to claim 1, wherein said manifold pressure set point is a threshold value above which the manifold pressure should not exceed.

45. (Previously Presented) Apparatus for optimizing operation of a vehicle according to claim 1, wherein said processor subsystem determines when to activate said fuel overinjection circuit and said upshift notification circuit based upon said manifold pressure set point and said RPM set point.

46. (Previously Presented) Apparatus for optimizing operation of a vehicle according to claim 1, wherein said determination to activate said fuel overinjection circuit is based on data from the road speed sensor.

47. (Previously Presented) Apparatus for optimizing operation of a vehicle according to claim 1, wherein said determination to activate said fuel overinjection circuit is based on data from the manifold pressure sensor.

48. (Previously Presented) Apparatus for optimizing operation of a vehicle according to claim 1, wherein said determination to activate said fuel overinjection circuit is based on data from the throttle position sensor.

49. (Previously Presented) Apparatus for optimizing operation of a vehicle according to claim 1, wherein said processor subsystem is configured to automatically power on when the vehicle is started.

50. (Previously Presented) Apparatus for optimizing operation of a vehicle according to claim 1, wherein said determination when to activate said fuel overinjection circuit and said determination when to activate said upshift

notification circuit is based upon said present and prior levels for said plurality of sensors stored in said memory subsystem.

51. (Previously Presented) Apparatus for optimizing operation of a vehicle according to claim 1, wherein said processor subsystem is configured to periodically communicate with said plurality of sensors.

52. (Previously Presented) Apparatus for optimizing operation of a vehicle according to claim 1, wherein said processor subsystem is configured to retrieve data from the plurality of sensors and store the data in said memory subsystem.

53. (Previously Presented) Apparatus for optimizing operation of a vehicle according to claim 17, wherein the processor subsystem includes (i) an active mode wherein the processor subsystem activates an alarm and reduces the throttle based upon a distance received from said radar detector, and (ii) an inactive mode wherein the processor subsystem activates an alarm and the processor subsystem does not reduce the throttle based upon a distance received from said radar detector.

54. (Previously Presented) Apparatus for optimizing operation of a vehicle according to claim 53, further comprising a means for mode selection between said active mode and said inactive mode.

55. (Previously Presented) Apparatus for optimizing operation of a vehicle according to claim 17, wherein said processor subsystem activates said upshift notification circuit based on the manifold pressure set point and RPM set point.

56. (Previously Presented) Apparatus for optimizing operation of a vehicle according to claim 17, wherein said at least one sensor is the road speed sensor.

Control No. 90013252

57. (Previously Presented) Apparatus for optimizing operation of a vehicle according to claim 17, wherein the first speed/stopping distance table is based on National Safety Council guidelines.

58. (Previously Presented) Apparatus for optimizing operation of a vehicle according to claim 17, further wherein said processor subsystem automatically applies the brakes based upon data received from said radar detector, said at least one sensor and said memory subsystem.

59. (Previously Presented) Apparatus for optimizing operation of a vehicle according to claim 28 further comprising:

a means for determining a distance separating a vehicle and an object, wherein the vehicle includes an engine; and

a vehicle proximity alarm circuit coupled to said processor subsystem;

wherein said processor subsystem activates said vehicle proximity alarm circuit based at least upon the data received from said road speed sensor, and the means for determining the distance separating the vehicle and the object.

61-84. (Canceled)

85. (Previously Submitted) Apparatus for optimizing operation of a vehicle, comprising:

a radar detector, said radar detector determining a distance separating a vehicle having an engine and an object in front of said vehicle;

a plurality of sensors coupled to said vehicle for monitoring operation thereof, said plurality of sensors including a road speed sensor and an engine speed sensor;

Control No. 90013252

a processor subsystem, coupled to said radar detector and said at least one sensor, to receive data therefrom;

a memory subsystem, coupled to said processor subsystem, said memory subsystem storing a first vehicle speed/stopping distance table;

a vehicle proximity alarm circuit coupled to said processor subsystem, said vehicle proximity alarm circuit issuing an alarm that said vehicle is too close to said object;

said processor subsystem determining whether to activate said vehicle proximity alarm circuit based upon separation distance data received from said radar detector, vehicle speed data received from said road speed sensor and said first vehicle speed/stopping distance table stored in said memory subsystem; and

a throttle controller for controlling a throttle of said engine of said vehicle;

wherein said processor subsystem selectively reduces said throttle based upon the data received from said radar detector;

further wherein the processor subsystem includes (i) an active mode in which the processor subsystem activates the vehicle proximity alarm circuit to issue the vehicle proximity alarm and reduces the throttle based upon the data received from said radar detector, and (ii) an inactive mode in which the processor subsystem activates the vehicle proximity alarm circuit to issue the alarm and the throttle is not selectively reduced based upon the data received from said radar detector;

a fuel overinjection notification circuit coupled to said processor subsystem, said fuel overinjection notification circuit issuing a notification that excessive fuel is

Control No. 90013252

being supplied to said engine of said vehicle;

wherein said processor subsystem determines whether to activate said fuel overinjection notification circuit based upon at least the data received from said road speed sensor.

86. (Previously Submitted) Apparatus for optimizing operation of a vehicle, comprising:

a tachometer;

a radar detector, said radar detector determining a distance separating a vehicle having an engine and an object in front of said vehicle;

a plurality of sensors coupled to said vehicle for monitoring operation thereof, said plurality of sensors including a road speed sensor, an engine speed sensor and a brake sensor;

a processor subsystem, coupled to said radar detector and said at least one sensor, to receive data therefrom;

a memory subsystem including random access memory, coupled to said processor subsystem, said memory subsystem storing a first vehicle speed/stopping distance table;

a vehicle proximity alarm circuit coupled to said processor subsystem, said vehicle proximity alarm circuit issuing an alarm that said vehicle is too close to said object;

said processor subsystem determining whether to activate said vehicle proximity alarm circuit based upon separation distance data received from said

Control No. 90013252

radar detector, vehicle speed data received from said road speed sensor and said first vehicle speed/stopping distance table stored in said memory subsystem;

a throttle controller for controlling a throttle of said engine of said vehicle;

wherein said processor subsystem selectively reduces said throttle based upon the data received from said radar detector;

further wherein the processor subsystem includes (i) an active mode in which the processor subsystem activates the vehicle proximity alarm circuit to issue the vehicle proximity alarm and reduces the throttle based upon the data received from said radar detector, and (ii) an inactive mode in which the processor subsystem activates the vehicle proximity alarm circuit to issue the alarm and the throttle is not selectively reduced based upon the data received from said radar detector;

an upshift notification circuit coupled to said processor subsystem.

87. (Previously Submitted) Apparatus for optimizing operation of a vehicle, comprising:

a radar detector, said radar detector determining a distance separating a vehicle having an engine and an object in front of said vehicle;

a plurality of sensors coupled to said vehicle for monitoring operation thereof, said plurality of sensors including a road speed sensor, an engine speed sensor and a brake sensor;

a processor subsystem, coupled to said radar detector and said at least one sensor, to receive data therefrom;

a memory subsystem, coupled to said processor subsystem, said memory

Control No. 90013252

subsystem storing a first vehicle speed/stopping distance table and an RPM set point;

a vehicle proximity alarm circuit coupled to said processor subsystem, said vehicle proximity alarm circuit issuing an alarm that said vehicle is too close to said object;

said processor subsystem determining whether to activate said vehicle proximity alarm circuit based upon separation distance data received from said radar detector, vehicle speed data received from said road speed sensor and said first vehicle speed/stopping distance table stored in said memory subsystem;

a throttle controller for controlling a throttle of said engine of said vehicle;

wherein said processor subsystem selectively reduces said throttle based upon the data received from said radar detector;

further wherein the processor subsystem includes (i) an active mode in which the processor subsystem activates the vehicle proximity alarm circuit to issue the vehicle proximity alarm and reduces the throttle based upon the data received from said radar detector, and (ii) an inactive mode in which the processor subsystem activates the vehicle proximity alarm circuit to issue the alarm and the throttle is not selectively reduced based upon the data received from said radar detector;

further wherein said processor subsystem determines whether a brake of the vehicle is activated based upon data received from the brake sensor.

[87. (Previously Presented) Apparatus for optimizing operation of a vehicle according to claim 85, further comprising:

Control No. 90013252

a display;

wherein the vehicle proximity alarm includes at least one of an audible and a visual indication; and

wherein the visual indication is displayed on the display.]

88. (Previously Presented) Apparatus for optimizing operation of a vehicle according to claim 87, further comprising means for mode selection between said active mode and said inactive mode.

89. (Previously Presented) Apparatus for optimizing operation of a vehicle according to claim 88, further comprising an upshift notification circuit coupled to said processor subsystem, said upshift notification circuit issuing a a notification that said engine of said vehicle is being operated at an excessive speed.

90. (Previously Presented) Apparatus for optimizing operation of a vehicle according to claim 89, further comprising a downshift notification circuit coupled to said processor subsystem, said downshift notification circuit issuing a notification that said engine of said vehicle is being operated at an insufficient engine speed.

91. (Previously Presented) Apparatus for optimizing operation of a vehicle according to claim 88, further comprising a selector for selecting a type of vehicle proximity alarm, wherein the type of vehicle proximity alarm is selected from the group consisting of an audible indication, a visual indication, and combinations thereof.

92. (Previously Presented) Apparatus for optimizing operation of a vehicle according to claim 85, wherein said first speed/stopping distance table is a lookup table.



93. (Previously Presented) Apparatus for optimizing operation of a vehicle according to claim 85, wherein said first speed/stopping distance table is based upon National Safety Council guidelines.

94. (Previously Presented) Apparatus for optimizing operation of a vehicle according to claim 88, further comprising a bus for bidirectional exchanges of address, data and control signals between said processor subsystem and said memory subsystem.

95. (Previously Presented) Apparatus for optimizing operation of a vehicle according to claim 94, wherein said memory subsystem includes at least one register for holding the level of said road speed sensor.

96. (Previously Presented) Apparatus for optimizing operation of a vehicle according to claim 88, further comprising a speedometer.

97. (Previously Presented) Apparatus for optimizing operation of a vehicle according to claim 85, wherein said vehicle comprises a truck.

98. (Previously Presented) Apparatus for optimizing operation of a vehicle according to claim 88, further comprising a power source including voltage divider circuitry.

99. (Previously Presented) Apparatus for optimizing operation of a vehicle according to claim 85, wherein said memory subsystem stores vehicle class information.

100. (Previously Presented) Apparatus for optimizing operation of a vehicle according to claim 85, wherein said processor subsystem is configured to automatically power on when the vehicle is started.

101. (Previously Presented) Apparatus for optimizing operation of a vehicle according to claim 88, wherein said processor subsystem is configured to retrieve data from said road speed sensor and store the data in said memory subsystem.

102. (Previously Presented) Apparatus for optimizing operation of a vehicle according to claim 88, wherein said processor subsystem is configured to wait a preselected time period after issuing the vehicle proximity alarm.

103. (Previously Presented) Apparatus for optimizing operation of a vehicle according to claim 88, wherein said processor subsystem is configured to select a type of vehicle proximity alarm based on the determined distance, wherein the type of vehicle proximity alarm is selected from the group consisting of an audible indication, a visual indication, and combinations thereof.

104. (Previously Presented) Apparatus for optimizing operation of a vehicle according to claim 85, wherein said first speed/stopping distance table is the relationship between vehicle speed and stopping distance.

105. (Previously Presented) Apparatus for optimizing operation of a vehicle according to claim 85 wherein:

said plurality of sensors further including a windshield wiper sensor for indicating whether a windshield wiper of said vehicle is activated; and

said memory subsystem further storing a second vehicle speed/stopping distance table;

if said windshield wiper sensor indicates that said windshield wiper is deactivated, said processor subsystem determining whether to activate said vehicle proximity alarm circuit based upon data received from said radar detector, said

Control No. 90013252

road speed sensor and said first vehicle speed/stopping distance table stored in said memory subsystem;

if said windshield wiper sensor indicates that said windshield wiper is activated, said processor subsystem determining whether to activate said vehicle proximity alarm circuit based upon data received from said radar detector, said road speed sensor and said second vehicle speed/stopping distance table stored in said memory subsystem.

106. (Previously Presented) Apparatus for optimizing operation of a vehicle according to claim 86, further comprising means for mode selection between said active mode and said inactive mode.

107. (Previously Presented) Apparatus for optimizing operation of a vehicle according to claim 106, further comprising:

a display;

wherein the vehicle proximity alarm includes at least one of an audible and a visual indication; and

wherein the visual indication is displayed on the display.

108. (Previously Presented) Apparatus for optimizing operation of a vehicle according to claim 107, further comprising a selector for selecting a type of vehicle proximity alarm, wherein the type of vehicle proximity alarm is selected from the group consisting of an audible indication, a visual indication, and combinations thereof.

109. (Previously Presented) Apparatus for optimizing operation of a vehicle according to claim 86, wherein said processor subsystem tracks the number of

vehicle proximity alarms issued before corrective action eliminates a hazardous condition.

110. (Previously Presented) Apparatus for optimizing operation of a vehicle according to claim 108, wherein said memory subsystem stores vehicle class information.

111. (Previously Presented) Apparatus for optimizing operation of a vehicle according to claim 108, wherein said processor subsystem is configured to select a type of vehicle proximity alarm based on the determined distance, wherein the type of vehicle proximity alarm is selected from the group consisting of an audible indication, a visual indication, and combinations thereof.

112. (Previously Presented) Apparatus for optimizing operation of a vehicle according to claim 111, further comprising a fuel overinjection notification circuit coupled to said processor subsystem, said fuel overinjection notification circuit issuing a notification that excessive fuel is being supplied to said engine of said vehicle.

113. (Previously Presented) Apparatus for optimizing operation of a vehicle according to claim 87, further comprising:

an upshift notification circuit coupled to said processor subsystem, said upshift notification circuit issuing a notification that said engine of said vehicle is being operated at an excessive speed; and

said processor subsystem determining, based upon whether engine speed exceeds said RPM set point, when to activate said upshift notification circuit.

Control No. 90013252

114. (Previously Presented) Apparatus for optimizing operation of a vehicle according to claim 87, further comprising a selector for selecting a type of vehicle proximity alarm, wherein the type of vehicle proximity alarm is selected from the group consisting of an audible indication, a visual indication, and combinations thereof.

115. (New) Apparatus for optimizing operation of a vehicle according to claim 85, further comprising:

a display;

wherein the vehicle proximity alarm includes at least one of an audible and a visual indication; and

wherein the visual indication is displayed on the display.

**Remarks**

This Supplemental Response is being submitted to correct duplicate claim number 87. There is a first claim 87 and a second claim 87. This Response is deleting the text of the second claim 87. The subject matter of the second claim 87 has been introduced as new claim 115. No new matter has been added.

Please note, the Supplemental Response submitted February 20, 2015, was submitted to correct a typographical error in claims 85-87. The error included the text “[at least one]”. The Supplemental Response filed February 20, 2015, deleted the text by using single brackets on each side of the text, thus, “[[at least one]]”.

**Conclusion**

In view of the foregoing remarks, Patent Owner submits that all of the currently pending claims are in allowable form and that the application is in condition for allowance. Therefore, Patent Owner respectfully requests that a timely Reexamination Certificate confirming the present claims be issued in this case. If for any reason the Examiner is unable to issue a Reexamination Certificate confirming the present claims the application and feels that an interview would be helpful to resolve any remaining issues, the Examiner is requested to contact the undersigned attorney at (312) 283-8555.

Respectfully submitted,

RICHARDS PATENT LAW PC



Patrick D. Richards  
Registration. No. 48,905

**Please recognize Customer No. 88360  
as the correspondence address.**

Richards Patent Law P.C.  
233 S. Wacker Dr., 84<sup>th</sup> Floor  
Chicago, IL 60606  
Phone: (312) 283-8555  
**Date: February 25, 2015**

## Electronic Acknowledgement Receipt

<b>EFS ID:</b>	21603409
<b>Application Number:</b>	90013252
<b>International Application Number:</b>	
<b>Confirmation Number:</b>	9999
<b>Title of Invention:</b>	Method and Apparatus for Optimizing Vehicle Operation
<b>First Named Inventor/Applicant Name:</b>	5,954,781
<b>Customer Number:</b>	88360
<b>Filer:</b>	Patrick Duffy Richards
<b>Filer Authorized By:</b>	
<b>Attorney Docket Number:</b>	
<b>Receipt Date:</b>	25-FEB-2015
<b>Filing Date:</b>	22-MAY-2014
<b>Time Stamp:</b>	22:58:27
<b>Application Type:</b>	Reexam (Third Party)

### Payment information:

Submitted with Payment	no
------------------------	----

### File Listing:

Document Number	Document Description	File Name	File Size(Bytes)/ Message Digest	Multi Part /.zip	Pages (if appl.)
1	Supplemental Response or Supplemental Amendment	1089-001SupplementalAmendment.pdf	204642 <small>54539ef8d11a670991b30d452b0f6147e90ccdad</small>	no	35

### Warnings:

### Information:



This Acknowledgement Receipt evidences receipt on the noted date by the USPTO of the indicated documents, characterized by the applicant, and including page counts, where applicable. It serves as evidence of receipt similar to a Post Card, as described in MPEP 503.

**New Applications Under 35 U.S.C. 111**

If a new application is being filed and the application includes the necessary components for a filing date (see 37 CFR 1.53(b)-(d) and MPEP 506), a Filing Receipt (37 CFR 1.54) will be issued in due course and the date shown on this Acknowledgement Receipt will establish the filing date of the application.

**National Stage of an International Application under 35 U.S.C. 371**

If a timely submission to enter the national stage of an international application is compliant with the conditions of 35 U.S.C. 371 and other applicable requirements a Form PCT/DO/EO/903 indicating acceptance of the application as a national stage submission under 35 U.S.C. 371 will be issued in addition to the Filing Receipt, in due course.

**New International Application Filed with the USPTO as a Receiving Office**

If a new international application is being filed and the international application includes the necessary components for an international filing date (see PCT Article 11 and MPEP 1810), a Notification of the International Application Number and of the International Filing Date (Form PCT/RO/105) will be issued in due course, subject to prescriptions concerning national security, and the date shown on this Acknowledgement Receipt will establish the international filing date of the application.

Docket No. 1089-001

**PATENT**

**IN THE UNITED STATES PATENT AND TRADEMARK OFFICE**

**Control No.** : 90013252                      **Confirmation No.** : 9999  
**Patent No.** : 5,954,781  
**Applicant** : Harvey Slepian  
**Reexam Filed:** May 22, 2014  
**Art Unit.** : 3992  
**Examiner** : David E. England  
**Customer No.:** 88360

Commissioner for Patents  
P.O. Box 1450  
Alexandria, VA 22313-1450

**RESPONSE**

Sir:

This Supplemental Response is being submitted in the above-identified Reexamination. Please amend the above-identified application as follows:

**Amendments to the Claims** are reflected in the listing of claims, which begins on page 2 of this paper.

**Remarks/Arguments** begin on page 34 of this paper.

### **Amendments to the Claims**

This listing of claims will replace all prior versions, and listings, of claims in the application:

#### **Listing of Claims**

1. (Original) Apparatus for optimizing operation of a vehicle, comprising:

a plurality of sensors coupled to a vehicle having an engine, said plurality of sensors, which collectively monitor operation of said vehicle, including a road speed sensor, an engine speed sensor, a manifold pressure sensor and a throttle position sensor;

a processor subsystem, coupled to each one of said plurality of sensors, to receive data therefrom;

a memory subsystem, coupled to said processor subsystem, said memory subsystem storing therein a manifold pressure set point, an RPM set point, and present and prior levels for each one of said plurality of sensors;

a fuel overinjection notification circuit coupled to said processor subsystem, said fuel overinjection notification circuit issuing a notification that excessive fuel is being supplied to said engine of said vehicle;

an upshift notification circuit coupled to said processor subsystem, said upshift notification circuit issuing a notification that said engine of said vehicle is being operated at an excessive speed;

said processor subsystem determining, based upon data received from said plurality of sensors, when to activate said fuel overinjection circuit and when to activate said upshift notification circuit.

2. (Original) Apparatus for optimizing operation of a vehicle according to claim 1 wherein said processor subsystem further comprises:

means for determining when road speed for said vehicle is increasing;

means for determining when throttle position for said vehicle is increasing;

and

means for comparing manifold pressure to said manifold pressure set point;

said processor subsystem activating said fuel overinjection notification circuit if both road speed and throttle position for said vehicle are increasing and manifold pressure for said vehicle is above said manifold pressure set point.

3. (Original) Apparatus for optimizing operation of a vehicle according to claim 1 wherein said fuel overinjection circuit further comprises a horn for issuing a tone for a preselected time period.

4. (Original) Apparatus for optimizing operation of a vehicle according to claim 1 wherein said processor subsystem further comprises:

means for determining when road speed for said vehicle is decreasing;

means for determining when throttle position for said vehicle is increasing;

means for determining when manifold pressure for said vehicle is increasing;

and

means for determining when engine speed for said vehicle is decreasing;

said processor subsystem activating said fuel overinjection notification

Control No. 90013252

circuit if both throttle position and manifold pressure for said vehicle are increasing and road speed and engine speed for said vehicle are decreasing.

5. (Original) Apparatus for optimizing operation of a vehicle according to claim 1 wherein said processor subsystem further comprises:

means for determining when road speed for said vehicle is increasing;

means for determining when throttle position for said vehicle is increasing;

means for comparing manifold pressure to said manifold pressure set point;

and

means for comparing engine speed to said RPM set point;

said processor subsystem activating said upshift notification circuit if both road speed and throttle position for said vehicle are increasing, manifold pressure for said vehicle is at or below said manifold pressure set point and engine speed for said vehicle is at or above said RPM set point.

6. (Original) Apparatus for optimizing operation of a vehicle according to claim 1 wherein said upshift notification circuit further comprises a horn for issuing a tone for a preselected time period.

7. (Original) Apparatus for optimizing operation of a vehicle, comprising:

a plurality of sensors coupled to a vehicle having an engine, said plurality of sensors, which collectively monitor operation of said vehicle, including a road speed sensor, a manifold pressure sensor and a throttle position sensor;

Control No. 90013252

a processor subsystem, coupled to each one of said plurality of sensors, to receive data therefrom;

a memory subsystem, coupled to said processor subsystem, said memory subsystem storing therein a manifold pressure set point and present and prior levels for each one of said plurality of sensors;

a fuel overinjection notification circuit coupled to said processor subsystem, said fuel overinjection notification circuit issuing a notification that excessive fuel is being supplied to said engine of said vehicle;

a downshift notification circuit coupled to said processor subsystem, said downshift notification circuit issuing a notification that said engine of said vehicle is being operated at an insufficient engine speed; and

said processor subsystem determining, based upon data received from said plurality of sensors, when to activate said fuel overinjection circuit and when to activate said downshift notification circuit.

8. (Original) Apparatus for optimizing operation of a vehicle according to claim 7 wherein said processor subsystem further comprises:

means for determining when road speed for said vehicle is increasing;

means for determining when throttle position for said vehicle is increasing;

and

means for comparing manifold pressure to said manifold pressure set point;

said processor subsystem activating said fuel overinjection notification circuit if both road speed and throttle position for said vehicle are increasing and

Control No. 90013252

manifold pressure for said vehicle is above said manifold pressure set point.

9. (Original) Apparatus for optimizing operation of a vehicle according to claim 7 wherein said fuel overinjection circuit further comprises a horn for issuing a tone for a preselected time period.

10. (Original) Apparatus for optimizing operation of a vehicle according to claim 7 wherein said processor subsystem further comprises:

means for determining when road speed for said vehicle is decreasing;

means for determining when throttle position for said vehicle is increasing;

means for determining when manifold pressure for said vehicle is increasing;

and

means for determining when engine speed for said vehicle is decreasing;

said processor subsystem activating said downshift notification circuit if both road speed and engine speed are decreasing and both throttle position and manifold pressure for said vehicle are increasing.

11. (Original) Apparatus for optimizing operation of a vehicle according to claim 10 wherein said downshift notification circuit further comprises a horn for issuing a tone for a preselected time period.

12. (Original) Apparatus for optimizing operation of a vehicle according to claim 7 wherein said processor subsystem further comprises:

Control No. 90013252

means for determining when road speed for said vehicle is decreasing;

means for determining when throttle position for said vehicle is increasing;

means for determining when manifold pressure for said vehicle is increasing;

and

means for determining when engine speed for said vehicle is decreasing;

said processor subsystem activating said fuel overinjection notification circuit if both throttle position and manifold pressure for said vehicle are increasing and road speed and engine speed for said vehicle are decreasing.

13. (Original) Apparatus for optimizing operation of a vehicle, comprising:

a plurality of sensors coupled to a vehicle having an engine, said plurality of sensors, which collectively monitor operation of said vehicle, including a road speed sensor, an engine speed sensor, a manifold pressure sensor and a throttle position sensor;

a processor subsystem, coupled to each one of said plurality of sensors, to receive data therefrom;

a memory subsystem, coupled to said processor subsystem, said memory subsystem storing therein a manifold pressure set point, an engine speed set point and present and prior levels for each one of said plurality of sensors;

a fuel overinjection notification circuit coupled to said processor subsystem, said fuel overinjection notification circuit issuing a notification that excessive fuel is being supplied to said engine of said vehicle;

an upshift notification circuit coupled to said processor subsystem, said



Control No. 90013252

upshift notification circuit issuing a notification that said engine of said vehicle is being operated at an excessive engine speed;

a downshift notification circuit coupled to said processor subsystem, said downshift notification circuit issuing a notification that said engine of said vehicle is being operated at an insufficient engine speed;

said processor subsystem determining, based upon data received from said plurality of sensors, when to activate said fuel overinjection circuit, said upshift notification circuit and said downshift notification circuit.

14. (Original) Apparatus for optimizing operation of a vehicle according to claim 13 wherein:

said fuel overinjection circuit further comprises a first horn for issuing a first tone for a first preselected time period;

said upshift notification circuit further comprises a second horn for issuing a second tone for a second preselected time period; and

said downshift notification circuit further comprises a third horn for issuing a third tone for a third preselected time period.

15. (Original) Apparatus for optimizing vehicle performance according to claim 13 wherein said processor subsystem further comprises:

means for determining when road speed for said vehicle is increasing or decreasing

means for determining when throttle position for said vehicle is increasing;

Control No. 90013252

means for comparing manifold pressure to said manifold pressure set point;

means for comparing engine speed to said RPM set point;

means for determining when manifold pressure is increasing; and

means for determining when engine speed is increasing or decreasing;

said processor subsystem activating said fuel overinjection notification circuit if both road speed and throttle position for said vehicle are increasing and manifold pressure for said vehicle is above said manifold pressure set or if both throttle position and manifold pressure for said vehicle are increasing and road speed and engine speed for said vehicle are decreasing;

said processor subsystem activating said upshift notification circuit if both road speed and throttle position for said vehicle are increasing, manifold pressure for said vehicle is at or below said manifold pressure set point and engine speed for said vehicle is at or above said RPM set point; and

said processor subsystem activating said downshift notification circuit if both road speed and engine speed are decreasing and both throttle position and manifold pressure for said vehicle are increasing.

16. (Original) Apparatus for optimizing operation of a vehicle according to claim 15 wherein:

said fuel overinjection circuit further comprises a first horn for issuing a first tone for a first preselected time period;

said upshift notification circuit further comprises a second horn for issuing a second tone for a second preselected time period; and

said downshift notification circuit further comprises a third horn for issuing a third tone for a third preselected time period.

17. (Original) Apparatus for optimizing operation of a vehicle, comprising:

a radar detector, said radar detector determining a distance separating a vehicle having an engine and an object in front of said vehicle;

at least one sensor coupled to said vehicle for monitoring operation thereof, said at least one sensor including a road speed sensor, a manifold pressure sensor, a throttle position sensor and an engine speed sensor;

a processor subsystem, coupled to said radar detector and said at least one sensor, to receive data therefrom;

a memory subsystem, coupled to said processor subsystem, said memory subsystem storing a first vehicle speed/stopping distance table, a manifold pressure set point, an RPM set point, a present level for each one of said at least one sensor and a prior level for each one of said at least one sensor;

a vehicle proximity alarm circuit coupled to said processor subsystem, said vehicle proximity alarm circuit issuing an alarm that said vehicle is too close to said object;

a fuel overinjection circuit coupled to said processor subsystem, said fuel overinjection circuit issuing a notification that excessive fuel is being supplied to said engine of said vehicle;

an upshift notification circuit coupled to said processor subsystem, said upshift notification circuit issuing a notification that said engine of said vehicle is

Control No. 90013252

being operated at an excessive speed;

said processor subsystem determining, based upon data received from said radar detector, said at least one sensor and said memory subsystem, when to activate said vehicle proximity alarm circuit, when to activate said fuel overinjection circuit, and when to activate said upshift notification circuit.

18. (Original) Apparatus for optimizing operation of a vehicle according to claim 17 wherein:

said at least one sensor further includes a windshield wiper sensor for indicating whether a windshield wiper of said vehicle is activated; and

said memory subsystem further storing a second vehicle speed/stopping distance table.

19. (Original) Apparatus for optimizing operation of a vehicle according to claim 17 and further comprising:

a throttle controller for controlling a throttle of said engine of said vehicle; and

said processor subsystem selectively reducing said throttle based upon data received from said radar detector, said at least one sensor and said memory subsystem.

20. (Original) Apparatus for optimizing operation of a vehicle according to claim 19 wherein said at least one sensor further includes a brake sensor for indicating

Control No. 90013252

whether a brake system of said vehicle is activated.

21. (Original) Apparatus for optimizing operation of a vehicle according to claim 19 wherein said processor subsystem further comprises:

means for counting a total number of vehicle proximity alarms determined by said processor subsystem;

means for selectively reducing said throttle based upon said total number of vehicle proximity alarms.

22. (Original) Apparatus for optimizing operation of a vehicle according to claim 17 and further comprising:

a downshift notification circuit coupled to said processor subsystem, said downshift notification circuit issuing a notification that said engine of said vehicle is being operated at an insufficient engine speed; and

said processor subsystem determining, based upon data received from said plurality of sensors, when to activate said downshift notification circuit.

23. (Original) Apparatus for optimizing operation of a vehicle, comprising:

a radar detector, said radar detector determining a distance separating a vehicle having an engine and an object in front of said vehicle;

a plurality of sensors coupled to a vehicle having an engine, said plurality of sensors, which collectively monitor operation of said vehicle, including a road speed sensor, and engine speed sensor, a manifold pressure sensor and a throttle position

Control No. 90013252

sensor;

a processor subsystem, coupled to said radar detector and each one of said plurality of sensors, to receive data therefrom;

a memory subsystem, coupled to said processor subsystem, said memory subsystem storing therein a first vehicle speed/stopping distance table, a manifold pressure set point, an RPM set point, and present and prior levels for each one of said plurality of sensors;

a fuel overinjection notification circuit coupled to said processor subsystem, said fuel overinjection notification circuit issuing a notification that excessive fuel is being supplied to said engine of said vehicle;

an upshift notification circuit coupled to said processor subsystem, said upshift notification circuit issuing a notification that said engine of said vehicle is being operated at an excessive engine speed;

said processor subsystem determining, based upon data received from said plurality of sensors, when to activate said fuel overinjection circuit and when to activate said upshift notification circuit;

a vehicle proximity alarm circuit coupled to said processor subsystem, said vehicle proximity alarm circuit issuing an alarm that said vehicle is too close to said object;

said processor subsystem determining, based upon data received from said radar detector, said at least one sensor and said memory subsystem, when to activate said vehicle proximity alarm circuit.

Control No. 90013252

24. (Original) Apparatus for optimizing operation of a vehicle according to claim 23 wherein said processor subsystem further comprises:

means for determining when road speed for said vehicle is increasing or decreasing;

means for determining when throttle position for said vehicle is increasing or decreasing; and

means for comparing manifold pressure to said manifold pressure set point;

means for determining when manifold pressure for said vehicle is increasing or decreasing; and

means for determining when engine speed for said vehicle is increasing or decreasing;

said processor subsystem activating said fuel overinjection notification circuit if both road speed and throttle position for said vehicle are increasing and manifold pressure for said vehicle is above said manifold pressure set point or if both throttle position and manifold pressure for said vehicle are increasing and road speed and engine speed for said vehicle are decreasing.

25. (Original) Apparatus for optimizing operation of a vehicle according to claim 23 wherein said processor subsystem further comprises:

means for determining when road speed for said vehicle is increasing;

means for determining when throttle position for said vehicle is increasing;

means for comparing manifold pressure to said manifold pressure set point;

and

means for comparing engine speed to said RPM set point;

said processor subsystem activating said upshift notification circuit if both road speed and throttle position for said vehicle are increasing, manifold pressure for said vehicle is at or below said manifold pressure set point and engine speed for said vehicle is at or above said RPM set point.

26. (Original) Apparatus for optimizing operation of a vehicle, comprising:

a radar detector, said radar detector determining a distance separating a vehicle having an engine and an object in front of said vehicle;

a plurality of sensors coupled to a vehicle having an engine, said plurality of sensors, which collectively monitor operation of said vehicle, including a road speed sensor, and engine speed sensor, a manifold pressure sensor and a throttle position sensor;

a processor subsystem, coupled to said radar detector and each one of said plurality of sensors, to receive data therefrom;

a memory subsystem, coupled to said processor subsystem, said memory subsystem storing therein a first vehicle speed/stopping distance table, a manifold pressure set point, RPM set point, and present and prior levels for each one of said plurality of sensors;

a fuel overinjection notification circuit coupled to said processor subsystem, said fuel overinjection notification circuit issuing a notification that excessive fuel is being supplied to said engine of said vehicle;

a downshift notification circuit coupled to said processor subsystem, said



Control No. 90013252

downshift notification circuit issuing a notification that said engine of said vehicle is being operated at an insufficient engine speed;

said processor subsystem determining, based upon data received from said plurality of sensors, when to activate said fuel overinjection circuit and when to activate said downshift notification circuit;

a vehicle proximity alarm circuit coupled to said processor subsystem, said vehicle proximity alarm circuit issuing an alarm that said vehicle is too close to said object;

said processor subsystem determining, based upon data received from said radar detector, said at least one sensor and said memory subsystem, when to activate said vehicle proximity alarm circuit.

27. (Original) Apparatus for optimizing operation of a vehicle according to claim 26 wherein said processor subsystem further comprises:

means for determining when road speed for said vehicle is decreasing;

means for determining when throttle position for said vehicle is increasing;

means for determining when manifold pressure for said vehicle is increasing;

and

means for determining when engine speed for said vehicle is decreasing;

said processor subsystem activating said downshift notification circuit if both road speed and engine speed are decreasing and both throttle position and manifold pressure for said vehicle are increasing.

28. (Original) Apparatus for optimizing operation of a vehicle, comprising:

a plurality of sensors coupled to a vehicle having an engine, said plurality of sensors, which collectively monitor operation of said vehicle, including a road speed sensor, a manifold pressure sensor and a throttle position sensor;

a processor subsystem, coupled to each one of said plurality of sensors, to receive data therefrom;

a fuel overinjection notification circuit coupled to said processor subsystem, said fuel overinjection notification circuit issuing a notification that excessive fuel is being supplied to said engine of said vehicle;

said processor subsystem determining whether to activate said fuel overinjection notification sensor based upon data received from said road speed sensor, said throttle position sensor and said manifold pressure sensor.

29. (Original) Apparatus according to claim 28 and further comprising:

a memory subsystem, coupled to said processor subsystem, said memory subsystem maintaining a manifold pressure set point;

said processor subsystem activating said fuel overinjection notification circuit upon determining that:

(1) based upon data received from said road speed sensor, road speed of said vehicle is increasing;

(2) based upon data received from said throttle position sensor, throttle position for said vehicle is increasing; and

(3) based upon data received from said manifold pressure sensor, manifold

Control No. 90013252

pressure for said vehicle exceeds said manifold pressure set point.

30. (Original) Apparatus according to claim 28, wherein:

said plurality of sensors coupled to said vehicle further include an engine speed sensor;

said processor subsystem activating said fuel overinjection notification circuit upon determining that:

(1) based upon data received from said road speed sensor, road speed of said vehicle is decreasing;

(2) based upon data received from said throttle position sensor, throttle position for said vehicle is increasing;

(3) based upon data received from said manifold pressure sensor, manifold pressure for said vehicle is increasing; and

(4) based upon data received from said engine speed sensor, engine speed for said vehicle is decreasing.

31-32. Canceled.

33. (Previously Presented) Apparatus for optimizing operation of a vehicle according to claim 1 further comprising:

means for determining a distance separating a vehicle and an object, wherein the vehicle includes an engine; and

a vehicle proximity alarm circuit coupled to said processor subsystem, wherein the vehicle proximity alarm circuit includes at least one of a visual notification and an audible notification;

wherein, upon the processor subsystem receiving the distance from said means for determining a distance and determining said distance is less than a predetermined distance, the processor subsystem activates the vehicle proximity alarm circuit.

34. (Previously Presented) Apparatus for optimizing operation of a vehicle according to claim 33, further comprising:

a throttle controller for controlling a throttle of said engine of said vehicle;

wherein, upon the processor subsystem receiving the distance from said means for determining a distance and determining said distance received is less than a predetermined distance, the processor subsystem reduces said throttle.

35. (Previously Presented) Apparatus for optimizing operation of a vehicle according to claim 33, further wherein the processor subsystem determines whether the brakes of the vehicle are activated.

36. (Previously Presented) Apparatus for optimizing operation of a vehicle according to claim 33, wherein the vehicle proximity alarm circuit further comprises a display for displaying at least one of the speed of the object, and the distance to the object.

37. (Previously Presented) Apparatus for optimizing operation of a vehicle according to claim 34, wherein the processor subsystem includes (i) an active mode wherein the processor subsystem activates an alarm and reduces the throttle based upon the distance received from said means for determining, and (ii) an inactive mode wherein the processor subsystem activates an alarm and the processor

Control No. 90013252

subsystem does not reduce the throttle based upon the distance received from said means for determining.

38. (Previously Presented) Apparatus for optimizing operation of a vehicle according to claim 37, further comprising a means for mode selection between said active mode and said inactive mode.

39. (Previously Presented) Apparatus for optimizing operation of a vehicle according to claim 1, wherein said plurality of sensors is the engine speed sensor and the vehicle speed sensor.

40. (Previously Presented) Apparatus for optimizing operation of a vehicle according to claim 1, wherein said notification that the engine is being operated an excessive speed comprises an automatic corrective action by the vehicle.

41. (Previously Presented) Apparatus for optimizing operation of a vehicle according to claim 1, wherein said notification that the engine is being operated at an excessive speed notifies a driver that an upshift should be performed.

42. (Previously Presented) Apparatus for optimizing operation of a vehicle according to claim 1, wherein said notification that excessive fuel is being supplied to said engine of said vehicle notifies a driver that the vehicle is not being operated fuel efficiently.

43. (Previously Presented) Apparatus for optimizing operation of a vehicle according to claim 1, wherein said manifold pressure set point is a manifold pressure threshold value.

44. (Previously Presented) Apparatus for optimizing operation of a vehicle according to claim 1, wherein said manifold pressure set point is a threshold value above which the manifold pressure should not exceed.

45. (Previously Presented) Apparatus for optimizing operation of a vehicle according to claim 1, wherein said processor subsystem determines when to activate said fuel overinjection circuit and said upshift notification circuit based upon said manifold pressure set point and said RPM set point.

46. (Previously Presented) Apparatus for optimizing operation of a vehicle according to claim 1, wherein said determination to activate said fuel overinjection circuit is based on data from the road speed sensor.

47. (Previously Presented) Apparatus for optimizing operation of a vehicle according to claim 1, wherein said determination to activate said fuel overinjection circuit is based on data from the manifold pressure sensor.

48. (Previously Presented) Apparatus for optimizing operation of a vehicle according to claim 1, wherein said determination to activate said fuel overinjection circuit is based on data from the throttle position sensor.

49. (Previously Presented) Apparatus for optimizing operation of a vehicle according to claim 1, wherein said processor subsystem is configured to automatically power on when the vehicle is started.

50. (Previously Presented) Apparatus for optimizing operation of a vehicle according to claim 1, wherein said determination when to activate said fuel overinjection circuit and said determination when to activate said upshift

notification circuit is based upon said present and prior levels for said plurality of sensors stored in said memory subsystem.

51. (Previously Presented) Apparatus for optimizing operation of a vehicle according to claim 1, wherein said processor subsystem is configured to periodically communicate with said plurality of sensors.

52. (Previously Presented) Apparatus for optimizing operation of a vehicle according to claim 1, wherein said processor subsystem is configured to retrieve data from the plurality of sensors and store the data in said memory subsystem.

53. (Previously Presented) Apparatus for optimizing operation of a vehicle according to claim 17, wherein the processor subsystem includes (i) an active mode wherein the processor subsystem activates an alarm and reduces the throttle based upon a distance received from said radar detector, and (ii) an inactive mode wherein the processor subsystem activates an alarm and the processor subsystem does not reduce the throttle based upon a distance received from said radar detector.

54. (Previously Presented) Apparatus for optimizing operation of a vehicle according to claim 53, further comprising a means for mode selection between said active mode and said inactive mode.

55. (Previously Presented) Apparatus for optimizing operation of a vehicle according to claim 17, wherein said processor subsystem activates said upshift notification circuit based on the manifold pressure set point and RPM set point.

56. (Previously Presented) Apparatus for optimizing operation of a vehicle according to claim 17, wherein said at least one sensor is the road speed sensor.

Control No. 90013252

57. (Previously Presented) Apparatus for optimizing operation of a vehicle according to claim 17, wherein the first speed/stopping distance table is based on National Safety Council guidelines.

58. (Previously Presented) Apparatus for optimizing operation of a vehicle according to claim 17, further wherein said processor subsystem automatically applies the brakes based upon data received from said radar detector, said at least one sensor and said memory subsystem.

59. (Previously Presented) Apparatus for optimizing operation of a vehicle according to claim 28 further comprising:

a means for determining a distance separating a vehicle and an object, wherein the vehicle includes an engine; and

a vehicle proximity alarm circuit coupled to said processor subsystem;

wherein said processor subsystem activates said vehicle proximity alarm circuit based at least upon the data received from said road speed sensor, and the means for determining the distance separating the vehicle and the object.

61-84. (Canceled)

85. (Currently Amended) Apparatus for optimizing operation of a vehicle, comprising:

a radar detector, said radar detector determining a distance separating a vehicle having an engine and an object in front of said vehicle;

a plurality of sensors coupled to said vehicle for monitoring operation thereof, said [[at least one]] plurality of sensors including a road speed sensor and an engine speed sensor;



Control No. 90013252

a processor subsystem, coupled to said radar detector and said at least one sensor, to receive data therefrom;

a memory subsystem, coupled to said processor subsystem, said memory subsystem storing a first vehicle speed/stopping distance table;

a vehicle proximity alarm circuit coupled to said processor subsystem, said vehicle proximity alarm circuit issuing an alarm that said vehicle is too close to said object;

said processor subsystem determining whether to activate said vehicle proximity alarm circuit based upon separation distance data received from said radar detector, vehicle speed data received from said road speed sensor and said first vehicle speed/stopping distance table stored in said memory subsystem; and

a throttle controller for controlling a throttle of said engine of said vehicle;

wherein said processor subsystem selectively reduces said throttle based upon the data received from said radar detector;

further wherein the processor subsystem includes (i) an active mode in which the processor subsystem activates the vehicle proximity alarm circuit to issue the vehicle proximity alarm and reduces the throttle based upon the data received from said radar detector, and (ii) an inactive mode in which the processor subsystem activates the vehicle proximity alarm circuit to issue the alarm and the throttle is not selectively reduced based upon the data received from said radar detector;

a fuel overinjection notification circuit coupled to said processor subsystem, said fuel overinjection notification circuit issuing a notification that excessive fuel is

Control No. 90013252

being supplied to said engine of said vehicle;

wherein said processor subsystem determines whether to activate said fuel overinjection notification circuit based upon at least the data received from said road speed sensor.

86. (Currently Amended) Apparatus for optimizing operation of a vehicle, comprising:

a tachometer;

a radar detector, said radar detector determining a distance separating a vehicle having an engine and an object in front of said vehicle;

a plurality of sensors coupled to said vehicle for monitoring operation thereof, said [[at least one]] plurality of sensors including a road speed sensor, an engine speed sensor and a brake sensor;

a processor subsystem, coupled to said radar detector and said at least one sensor, to receive data therefrom;

a memory subsystem including random access memory, coupled to said processor subsystem, said memory subsystem storing a first vehicle speed/stopping distance table;

a vehicle proximity alarm circuit coupled to said processor subsystem, said vehicle proximity alarm circuit issuing an alarm that said vehicle is too close to said object;

said processor subsystem determining whether to activate said vehicle proximity alarm circuit based upon separation distance data received from said

Control No. 90013252

radar detector, vehicle speed data received from said road speed sensor and said first vehicle speed/stopping distance table stored in said memory subsystem;

a throttle controller for controlling a throttle of said engine of said vehicle;

wherein said processor subsystem selectively reduces said throttle based upon the data received from said radar detector;

further wherein the processor subsystem includes (i) an active mode in which the processor subsystem activates the vehicle proximity alarm circuit to issue the vehicle proximity alarm and reduces the throttle based upon the data received from said radar detector, and (ii) an inactive mode in which the processor subsystem activates the vehicle proximity alarm circuit to issue the alarm and the throttle is not selectively reduced based upon the data received from said radar detector;

an upshift notification circuit coupled to said processor subsystem.

87. (Currently Amended) Apparatus for optimizing operation of a vehicle, comprising:

a radar detector, said radar detector determining a distance separating a vehicle having an engine and an object in front of said vehicle;

a plurality of sensors coupled to said vehicle for monitoring operation thereof, said [[at least one]] plurality of sensors including a road speed sensor, an engine speed sensor and a brake sensor;

a processor subsystem, coupled to said radar detector and said at least one sensor, to receive data therefrom;

a memory subsystem, coupled to said processor subsystem, said memory

Control No. 90013252

subsystem storing a first vehicle speed/stopping distance table and an RPM set point;

a vehicle proximity alarm circuit coupled to said processor subsystem, said vehicle proximity alarm circuit issuing an alarm that said vehicle is too close to said object;

said processor subsystem determining whether to activate said vehicle proximity alarm circuit based upon separation distance data received from said radar detector, vehicle speed data received from said road speed sensor and said first vehicle speed/stopping distance table stored in said memory subsystem;

a throttle controller for controlling a throttle of said engine of said vehicle;

wherein said processor subsystem selectively reduces said throttle based upon the data received from said radar detector;

further wherein the processor subsystem includes (i) an active mode in which the processor subsystem activates the vehicle proximity alarm circuit to issue the vehicle proximity alarm and reduces the throttle based upon the data received from said radar detector, and (ii) an inactive mode in which the processor subsystem activates the vehicle proximity alarm circuit to issue the alarm and the throttle is not selectively reduced based upon the data received from said radar detector;

further wherein said processor subsystem determines whether a brake of the vehicle is activated based upon data received from the brake sensor.

87. (Previously Presented) Apparatus for optimizing operation of a vehicle according to claim 85, further comprising:

Control No. 90013252

a display;

wherein the vehicle proximity alarm includes at least one of an audible and a visual indication; and

wherein the visual indication is displayed on the display.

88. (Previously Presented) Apparatus for optimizing operation of a vehicle according to claim 87, further comprising means for mode selection between said active mode and said inactive mode.

89. (Previously Presented) Apparatus for optimizing operation of a vehicle according to claim 88, further comprising an upshift notification circuit coupled to said processor subsystem, said upshift notification circuit issuing a a notification that said engine of said vehicle is being operated at an excessive speed.

90. (Previously Presented) Apparatus for optimizing operation of a vehicle according to claim 89, further comprising a downshift notification circuit coupled to said processor subsystem, said downshift notification circuit issuing a notification that said engine of said vehicle is being operated at an insufficient engine speed.

91. (Previously Presented) Apparatus for optimizing operation of a vehicle according to claim 88, further comprising a selector for selecting a type of vehicle proximity alarm, wherein the type of vehicle proximity alarm is selected from the group consisting of an audible indication, a visual indication, and combinations thereof.

92. (Previously Presented) Apparatus for optimizing operation of a vehicle according to claim 85, wherein said first speed/stopping distance table is a lookup table.

93. (Previously Presented) Apparatus for optimizing operation of a vehicle according to claim 85, wherein said first speed/stopping distance table is based upon National Safety Council guidelines.

94. (Previously Presented) Apparatus for optimizing operation of a vehicle according to claim 88, further comprising a bus for bidirectional exchanges of address, data and control signals between said processor subsystem and said memory subsystem.

95. (Previously Presented) Apparatus for optimizing operation of a vehicle according to claim 94, wherein said memory subsystem includes at least one register for holding the level of said road speed sensor.

96. (Previously Presented) Apparatus for optimizing operation of a vehicle according to claim 88, further comprising a speedometer.

97. (Previously Presented) Apparatus for optimizing operation of a vehicle according to claim 85, wherein said vehicle comprises a truck.

98. (Previously Presented) Apparatus for optimizing operation of a vehicle according to claim 88, further comprising a power source including voltage divider circuitry.

99. (Previously Presented) Apparatus for optimizing operation of a vehicle according to claim 85, wherein said memory subsystem stores vehicle class information.

100. (Previously Presented) Apparatus for optimizing operation of a vehicle according to claim 85, wherein said processor subsystem is configured to automatically power on when the vehicle is started.

101. (Previously Presented) Apparatus for optimizing operation of a vehicle according to claim 88, wherein said processor subsystem is configured to retrieve data from said road speed sensor and store the data in said memory subsystem.

102. (Previously Presented) Apparatus for optimizing operation of a vehicle according to claim 88, wherein said processor subsystem is configured to wait a preselected time period after issuing the vehicle proximity alarm.

103. (Previously Presented) Apparatus for optimizing operation of a vehicle according to claim 88, wherein said processor subsystem is configured to select a type of vehicle proximity alarm based on the determined distance, wherein the type of vehicle proximity alarm is selected from the group consisting of an audible indication, a visual indication, and combinations thereof.

104. (Previously Presented) Apparatus for optimizing operation of a vehicle according to claim 85, wherein said first speed/stopping distance table is the relationship between vehicle speed and stopping distance.

105. (Previously Presented) Apparatus for optimizing operation of a vehicle according to claim 85 wherein:

said plurality of sensors further including a windshield wiper sensor for indicating whether a windshield wiper of said vehicle is activated; and

said memory subsystem further storing a second vehicle speed/stopping distance table;

if said windshield wiper sensor indicates that said windshield wiper is deactivated, said processor subsystem determining whether to activate said vehicle proximity alarm circuit based upon data received from said radar detector, said

Control No. 90013252

road speed sensor and said first vehicle speed/stopping distance table stored in said memory subsystem;

if said windshield wiper sensor indicates that said windshield wiper is activated, said processor subsystem determining whether to activate said vehicle proximity alarm circuit based upon data received from said radar detector, said road speed sensor and said second vehicle speed/stopping distance table stored in said memory subsystem.

106. (Previously Presented) Apparatus for optimizing operation of a vehicle according to claim 86, further comprising means for mode selection between said active mode and said inactive mode.

107. (Previously Presented) Apparatus for optimizing operation of a vehicle according to claim 106, further comprising:

a display;

wherein the vehicle proximity alarm includes at least one of an audible and a visual indication; and

wherein the visual indication is displayed on the display.

108. (Previously Presented) Apparatus for optimizing operation of a vehicle according to claim 107, further comprising a selector for selecting a type of vehicle proximity alarm, wherein the type of vehicle proximity alarm is selected from the group consisting of an audible indication, a visual indication, and combinations thereof.

109. (Previously Presented) Apparatus for optimizing operation of a vehicle according to claim 86, wherein said processor subsystem tracks the number of



vehicle proximity alarms issued before corrective action eliminates a hazardous condition.

110. (Previously Presented) Apparatus for optimizing operation of a vehicle according to claim 108, wherein said memory subsystem stores vehicle class information.

111. (Previously Presented) Apparatus for optimizing operation of a vehicle according to claim 108, wherein said processor subsystem is configured to select a type of vehicle proximity alarm based on the determined distance, wherein the type of vehicle proximity alarm is selected from the group consisting of an audible indication, a visual indication, and combinations thereof.

112. (Previously Presented) Apparatus for optimizing operation of a vehicle according to claim 111, further comprising a fuel overinjection notification circuit coupled to said processor subsystem, said fuel overinjection notification circuit issuing a notification that excessive fuel is being supplied to said engine of said vehicle.

113. (Previously Presented) Apparatus for optimizing operation of a vehicle according to claim 87, further comprising:

an upshift notification circuit coupled to said processor subsystem, said upshift notification circuit issuing a notification that said engine of said vehicle is being operated at an excessive speed; and

said processor subsystem determining, based upon whether engine speed exceeds said RPM set point, when to activate said upshift notification circuit.

Control No. 90013252

114 (Previously Presented) Apparatus for optimizing operation of a vehicle according to claim 87, further comprising a selector for selecting a type of vehicle proximity alarm, wherein the type of vehicle proximity alarm is selected from the group consisting of an audible indication, a visual indication, and combinations thereof.

Control No. 90013252

**Remarks**

This Supplemental Response is being submitted to supplement the claim amendments submitted in the Response dated December 10, 2014.

Specifically, the present Supplemental Response is being submitted to correct a typographical error in claims 85-87.

**Conclusion**

In view of the foregoing remarks, Patent Owner submits that all of the currently pending claims are in allowable form and that the application is in condition for allowance. Therefore, Patent Owner respectfully requests that a timely Reexamination Certificate confirming the present claims be issued in this case. If for any reason the Examiner is unable to issue a Reexamination Certificate confirming the present claims the application and feels that an interview would be helpful to resolve any remaining issues, the Examiner is requested to contact the undersigned attorney at (312) 283-8555.

Respectfully submitted,

RICHARDS PATENT LAW PC



Patrick D. Richards  
Registration. No. 48,905

**Please recognize Customer No. 88360  
as the correspondence address.**

Richards Patent Law P.C.  
233 S. Wacker Dr., 84<sup>th</sup> Floor  
Chicago, IL 60606  
Phone: (312) 283-8555  
**Date: February 20, 2015**

## Electronic Acknowledgement Receipt

<b>EFS ID:</b>	21560612
<b>Application Number:</b>	90013252
<b>International Application Number:</b>	
<b>Confirmation Number:</b>	9999
<b>Title of Invention:</b>	Method and Apparatus for Optimizing Vehicle Operation
<b>First Named Inventor/Applicant Name:</b>	5,954,781
<b>Customer Number:</b>	88360
<b>Filer:</b>	Patrick Duffy Richards
<b>Filer Authorized By:</b>	
<b>Attorney Docket Number:</b>	
<b>Receipt Date:</b>	20-FEB-2015
<b>Filing Date:</b>	22-MAY-2014
<b>Time Stamp:</b>	17:28:32
<b>Application Type:</b>	Reexam (Third Party)

### Payment information:

Submitted with Payment	no
------------------------	----

### File Listing:

Document Number	Document Description	File Name	File Size(Bytes)/ Message Digest	Multi Part /.zip	Pages (if appl.)
1	Supplemental Response or Supplemental Amendment	1089-001SupplementalAmendment.pdf	202217 0a21087810b83e8f14df01cf59bee5afa7a946e6	no	35

### Warnings:

### Information:

This Acknowledgement Receipt evidences receipt on the noted date by the USPTO of the indicated documents, characterized by the applicant, and including page counts, where applicable. It serves as evidence of receipt similar to a Post Card, as described in MPEP 503.

**New Applications Under 35 U.S.C. 111**

If a new application is being filed and the application includes the necessary components for a filing date (see 37 CFR 1.53(b)-(d) and MPEP 506), a Filing Receipt (37 CFR 1.54) will be issued in due course and the date shown on this Acknowledgement Receipt will establish the filing date of the application.

**National Stage of an International Application under 35 U.S.C. 371**

If a timely submission to enter the national stage of an international application is compliant with the conditions of 35 U.S.C. 371 and other applicable requirements a Form PCT/DO/EO/903 indicating acceptance of the application as a national stage submission under 35 U.S.C. 371 will be issued in addition to the Filing Receipt, in due course.

**New International Application Filed with the USPTO as a Receiving Office**

If a new international application is being filed and the international application includes the necessary components for an international filing date (see PCT Article 11 and MPEP 1810), a Notification of the International Application Number and of the International Filing Date (Form PCT/RO/105) will be issued in due course, subject to prescriptions concerning national security, and the date shown on this Acknowledgement Receipt will establish the international filing date of the application.

Docket No. 1089-001

**PATENT**

**IN THE UNITED STATES PATENT AND TRADEMARK OFFICE**

**Control No.** : 90013252                      **Confirmation No.** : 9999  
**Patent No.** : 5,954,781  
**Applicant** : Harvey Slepian  
**Reexam Filed:** May 22, 2014  
**Art Unit.** : 3992  
**Examiner** : David E. England  
**Customer No.:** 88360

Commissioner for Patents  
P.O. Box 1450  
Alexandria, VA 22313-1450

**RESPONSE**

Sir:

This Supplemental Response is being submitted in the above-identified Reexamination. Please amend the above-identified application as follows:

**Amendments to the Claims** are reflected in the listing of claims, which begins on page 2 of this paper.

**Remarks/Arguments** begin on page 33 of this paper.

### **Amendments to the Claims**

This listing of claims will replace all prior versions, and listings, of claims in the application:

#### **Listing of Claims**

1. (Original) Apparatus for optimizing operation of a vehicle, comprising:

a plurality of sensors coupled to a vehicle having an engine, said plurality of sensors, which collectively monitor operation of said vehicle, including a road speed sensor, an engine speed sensor, a manifold pressure sensor and a throttle position sensor;

a processor subsystem, coupled to each one of said plurality of sensors, to receive data therefrom;

a memory subsystem, coupled to said processor subsystem, said memory subsystem storing therein a manifold pressure set point, an RPM set point, and present and prior levels for each one of said plurality of sensors;

a fuel overinjection notification circuit coupled to said processor subsystem, said fuel overinjection notification circuit issuing a notification that excessive fuel is being supplied to said engine of said vehicle;

an upshift notification circuit coupled to said processor subsystem, said upshift notification circuit issuing a notification that said engine of said vehicle is being operated at an excessive speed;

said processor subsystem determining, based upon data received from said plurality of sensors, when to activate said fuel overinjection circuit and when to activate said upshift notification circuit.



2. (Original) Apparatus for optimizing operation of a vehicle according to claim 1 wherein said processor subsystem further comprises:

means for determining when road speed for said vehicle is increasing;

means for determining when throttle position for said vehicle is increasing;

and

means for comparing manifold pressure to said manifold pressure set point;

said processor subsystem activating said fuel overinjection notification circuit if both road speed and throttle position for said vehicle are increasing and manifold pressure for said vehicle is above said manifold pressure set point.

3. (Original) Apparatus for optimizing operation of a vehicle according to claim 1 wherein said fuel overinjection circuit further comprises a horn for issuing a tone for a preselected time period.

4. (Original) Apparatus for optimizing operation of a vehicle according to claim 1 wherein said processor subsystem further comprises:

means for determining when road speed for said vehicle is decreasing;

means for determining when throttle position for said vehicle is increasing;

means for determining when manifold pressure for said vehicle is increasing;

and

means for determining when engine speed for said vehicle is decreasing;

said processor subsystem activating said fuel overinjection notification

Control No. 90013252

circuit if both throttle position and manifold pressure for said vehicle are increasing and road speed and engine speed for said vehicle are decreasing.

5. (Original) Apparatus for optimizing operation of a vehicle according to claim 1 wherein said processor subsystem further comprises:

means for determining when road speed for said vehicle is increasing;

means for determining when throttle position for said vehicle is increasing;

means for comparing manifold pressure to said manifold pressure set point;

and

means for comparing engine speed to said RPM set point;

said processor subsystem activating said upshift notification circuit if both road speed and throttle position for said vehicle are increasing, manifold pressure for said vehicle is at or below said manifold pressure set point and engine speed for said vehicle is at or above said RPM set point.

6. (Original) Apparatus for optimizing operation of a vehicle according to claim 1 wherein said upshift notification circuit further comprises a horn for issuing a tone for a preselected time period.

7. (Original) Apparatus for optimizing operation of a vehicle, comprising:

a plurality of sensors coupled to a vehicle having an engine, said plurality of sensors, which collectively monitor operation of said vehicle, including a road speed sensor, a manifold pressure sensor and a throttle position sensor;

Control No. 90013252

a processor subsystem, coupled to each one of said plurality of sensors, to receive data therefrom;

a memory subsystem, coupled to said processor subsystem, said memory subsystem storing therein a manifold pressure set point and present and prior levels for each one of said plurality of sensors;

a fuel overinjection notification circuit coupled to said processor subsystem, said fuel overinjection notification circuit issuing a notification that excessive fuel is being supplied to said engine of said vehicle;

a downshift notification circuit coupled to said processor subsystem, said downshift notification circuit issuing a notification that said engine of said vehicle is being operated at an insufficient engine speed; and

said processor subsystem determining, based upon data received from said plurality of sensors, when to activate said fuel overinjection circuit and when to activate said downshift notification circuit.

8. (Original) Apparatus for optimizing operation of a vehicle according to claim 7 wherein said processor subsystem further comprises:

means for determining when road speed for said vehicle is increasing;

means for determining when throttle position for said vehicle is increasing;

and

means for comparing manifold pressure to said manifold pressure set point;

said processor subsystem activating said fuel overinjection notification circuit if both road speed and throttle position for said vehicle are increasing and

Control No. 90013252

manifold pressure for said vehicle is above said manifold pressure set point.

9. (Original) Apparatus for optimizing operation of a vehicle according to claim 7 wherein said fuel overinjection circuit further comprises a horn for issuing a tone for a preselected time period.

10. (Original) Apparatus for optimizing operation of a vehicle according to claim 7 wherein said processor subsystem further comprises:

means for determining when road speed for said vehicle is decreasing;

means for determining when throttle position for said vehicle is increasing;

means for determining when manifold pressure for said vehicle is increasing;

and

means for determining when engine speed for said vehicle is decreasing;

said processor subsystem activating said downshift notification circuit if both road speed and engine speed are decreasing and both throttle position and manifold pressure for said vehicle are increasing.

11. (Original) Apparatus for optimizing operation of a vehicle according to claim 10 wherein said downshift notification circuit further comprises a horn for issuing a tone for a preselected time period.

12. (Original) Apparatus for optimizing operation of a vehicle according to claim 7 wherein said processor subsystem further comprises:

Control No. 90013252

means for determining when road speed for said vehicle is decreasing;

means for determining when throttle position for said vehicle is increasing;

means for determining when manifold pressure for said vehicle is increasing;

and

means for determining when engine speed for said vehicle is decreasing;

said processor subsystem activating said fuel overinjection notification circuit if both throttle position and manifold pressure for said vehicle are increasing and road speed and engine speed for said vehicle are decreasing.

13. (Original) Apparatus for optimizing operation of a vehicle, comprising:

a plurality of sensors coupled to a vehicle having an engine, said plurality of sensors, which collectively monitor operation of said vehicle, including a road speed sensor, an engine speed sensor, a manifold pressure sensor and a throttle position sensor;

a processor subsystem, coupled to each one of said plurality of sensors, to receive data therefrom;

a memory subsystem, coupled to said processor subsystem, said memory subsystem storing therein a manifold pressure set point, an engine speed set point and present and prior levels for each one of said plurality of sensors;

a fuel overinjection notification circuit coupled to said processor subsystem, said fuel overinjection notification circuit issuing a notification that excessive fuel is being supplied to said engine of said vehicle;

an upshift notification circuit coupled to said processor subsystem, said

Control No. 90013252

upshift notification circuit issuing a notification that said engine of said vehicle is being operated at an excessive engine speed;

a downshift notification circuit coupled to said processor subsystem, said downshift notification circuit issuing a notification that said engine of said vehicle is being operated at an insufficient engine speed;

said processor subsystem determining, based upon data received from said plurality of sensors, when to activate said fuel overinjection circuit, said upshift notification circuit and said downshift notification circuit.

14. (Original) Apparatus for optimizing operation of a vehicle according to claim 13 wherein:

said fuel overinjection circuit further comprises a first horn for issuing a first tone for a first preselected time period;

said upshift notification circuit further comprises a second horn for issuing a second tone for a second preselected time period; and

said downshift notification circuit further comprises a third horn for issuing a third tone for a third preselected time period.

15. (Original) Apparatus for optimizing vehicle performance according to claim 13 wherein said processor subsystem further comprises:

means for determining when road speed for said vehicle is increasing or decreasing

means for determining when throttle position for said vehicle is increasing;

Control No. 90013252

means for comparing manifold pressure to said manifold pressure set point;

means for comparing engine speed to said RPM set point;

means for determining when manifold pressure is increasing; and

means for determining when engine speed is increasing or decreasing;

said processor subsystem activating said fuel overinjection notification circuit if both road speed and throttle position for said vehicle are increasing and manifold pressure for said vehicle is above said manifold pressure set or if both throttle position and manifold pressure for said vehicle are increasing and road speed and engine speed for said vehicle are decreasing;

said processor subsystem activating said upshift notification circuit if both road speed and throttle position for said vehicle are increasing, manifold pressure for said vehicle is at or below said manifold pressure set point and engine speed for said vehicle is at or above said RPM set point; and

said processor subsystem activating said downshift notification circuit if both road speed and engine speed are decreasing and both throttle position and manifold pressure for said vehicle are increasing.

16. (Original) Apparatus for optimizing operation of a vehicle according to claim 15 wherein:

said fuel overinjection circuit further comprises a first horn for issuing a first tone for a first preselected time period;

said upshift notification circuit further comprises a second horn for issuing a second tone for a second preselected time period; and

said downshift notification circuit further comprises a third horn for issuing a third tone for a third preselected time period.

17. (Original) Apparatus for optimizing operation of a vehicle, comprising:

a radar detector, said radar detector determining a distance separating a vehicle having an engine and an object in front of said vehicle;

at least one sensor coupled to said vehicle for monitoring operation thereof, said at least one sensor including a road speed sensor, a manifold pressure sensor, a throttle position sensor and an engine speed sensor;

a processor subsystem, coupled to said radar detector and said at least one sensor, to receive data therefrom;

a memory subsystem, coupled to said processor subsystem, said memory subsystem storing a first vehicle speed/stopping distance table, a manifold pressure set point, an RPM set point, a present level for each one of said at least one sensor and a prior level for each one of said at least one sensor;

a vehicle proximity alarm circuit coupled to said processor subsystem, said vehicle proximity alarm circuit issuing an alarm that said vehicle is too close to said object;

a fuel overinjection circuit coupled to said processor subsystem, said fuel overinjection circuit issuing a notification that excessive fuel is being supplied to said engine of said vehicle;

an upshift notification circuit coupled to said processor subsystem, said upshift notification circuit issuing a notification that said engine of said vehicle is



Control No. 90013252

being operated at an excessive speed;

said processor subsystem determining, based upon data received from said radar detector, said at least one sensor and said memory subsystem, when to activate said vehicle proximity alarm circuit, when to activate said fuel overinjection circuit, and when to activate said upshift notification circuit.

18. (Original) Apparatus for optimizing operation of a vehicle according to claim 17 wherein:

said at least one sensor further includes a windshield wiper sensor for indicating whether a windshield wiper of said vehicle is activated; and

said memory subsystem further storing a second vehicle speed/stopping distance table.

19. (Original) Apparatus for optimizing operation of a vehicle according to claim 17 and further comprising:

a throttle controller for controlling a throttle of said engine of said vehicle; and

said processor subsystem selectively reducing said throttle based upon data received from said radar detector, said at least one sensor and said memory subsystem.

20. (Original) Apparatus for optimizing operation of a vehicle according to claim 19 wherein said at least one sensor further includes a brake sensor for indicating

Control No. 90013252

whether a brake system of said vehicle is activated.

21. (Original) Apparatus for optimizing operation of a vehicle according to claim 19 wherein said processor subsystem further comprises:

means for counting a total number of vehicle proximity alarms determined by said processor subsystem;

means for selectively reducing said throttle based upon said total number of vehicle proximity alarms.

22. (Original) Apparatus for optimizing operation of a vehicle according to claim 17 and further comprising:

a downshift notification circuit coupled to said processor subsystem, said downshift notification circuit issuing a notification that said engine of said vehicle is being operated at an insufficient engine speed; and

said processor subsystem determining, based upon data received from said plurality of sensors, when to activate said downshift notification circuit.

23. (Original) Apparatus for optimizing operation of a vehicle, comprising:

a radar detector, said radar detector determining a distance separating a vehicle having an engine and an object in front of said vehicle;

a plurality of sensors coupled to a vehicle having an engine, said plurality of sensors, which collectively monitor operation of said vehicle, including a road speed sensor, and engine speed sensor, a manifold pressure sensor and a throttle position

Control No. 90013252

sensor;

a processor subsystem, coupled to said radar detector and each one of said plurality of sensors, to receive data therefrom;

a memory subsystem, coupled to said processor subsystem, said memory subsystem storing therein a first vehicle speed/stopping distance table, a manifold pressure set point, an RPM set point, and present and prior levels for each one of said plurality of sensors;

a fuel overinjection notification circuit coupled to said processor subsystem, said fuel overinjection notification circuit issuing a notification that excessive fuel is being supplied to said engine of said vehicle;

an upshift notification circuit coupled to said processor subsystem, said upshift notification circuit issuing a notification that said engine of said vehicle is being operated at an excessive engine speed;

said processor subsystem determining, based upon data received from said plurality of sensors, when to activate said fuel overinjection circuit and when to activate said upshift notification circuit;

a vehicle proximity alarm circuit coupled to said processor subsystem, said vehicle proximity alarm circuit issuing an alarm that said vehicle is too close to said object;

said processor subsystem determining, based upon data received from said radar detector, said at least one sensor and said memory subsystem, when to activate said vehicle proximity alarm circuit.

Control No. 90013252

24. (Original) Apparatus for optimizing operation of a vehicle according to claim 23 wherein said processor subsystem further comprises:

means for determining when road speed for said vehicle is increasing or decreasing;

means for determining when throttle position for said vehicle is increasing or decreasing; and

means for comparing manifold pressure to said manifold pressure set point;

means for determining when manifold pressure for said vehicle is increasing or decreasing; and

means for determining when engine speed for said vehicle is increasing or decreasing;

said processor subsystem activating said fuel overinjection notification circuit if both road speed and throttle position for said vehicle are increasing and manifold pressure for said vehicle is above said manifold pressure set point or if both throttle position and manifold pressure for said vehicle are increasing and road speed and engine speed for said vehicle are decreasing.

25. (Original) Apparatus for optimizing operation of a vehicle according to claim 23 wherein said processor subsystem further comprises:

means for determining when road speed for said vehicle is increasing;

means for determining when throttle position for said vehicle is increasing;

means for comparing manifold pressure to said manifold pressure set point;

and

means for comparing engine speed to said RPM set point;

said processor subsystem activating said upshift notification circuit if both road speed and throttle position for said vehicle are increasing, manifold pressure for said vehicle is at or below said manifold pressure set point and engine speed for said vehicle is at or above said RPM set point.

26. (Original) Apparatus for optimizing operation of a vehicle, comprising:

a radar detector, said radar detector determining a distance separating a vehicle having an engine and an object in front of said vehicle;

a plurality of sensors coupled to a vehicle having an engine, said plurality of sensors, which collectively monitor operation of said vehicle, including a road speed sensor, and engine speed sensor, a manifold pressure sensor and a throttle position sensor;

a processor subsystem, coupled to said radar detector and each one of said plurality of sensors, to receive data therefrom;

a memory subsystem, coupled to said processor subsystem, said memory subsystem storing therein a first vehicle speed/stopping distance table, a manifold pressure set point, RPM set point, and present and prior levels for each one of said plurality of sensors;

a fuel overinjection notification circuit coupled to said processor subsystem, said fuel overinjection notification circuit issuing a notification that excessive fuel is being supplied to said engine of said vehicle;

a downshift notification circuit coupled to said processor subsystem, said

Control No. 90013252

downshift notification circuit issuing a notification that said engine of said vehicle is being operated at an insufficient engine speed;

said processor subsystem determining, based upon data received from said plurality of sensors, when to activate said fuel overinjection circuit and when to activate said downshift notification circuit;

a vehicle proximity alarm circuit coupled to said processor subsystem, said vehicle proximity alarm circuit issuing an alarm that said vehicle is too close to said object;

said processor subsystem determining, based upon data received from said radar detector, said at least one sensor and said memory subsystem, when to activate said vehicle proximity alarm circuit.

27. (Original) Apparatus for optimizing operation of a vehicle according to claim 26 wherein said processor subsystem further comprises:

means for determining when road speed for said vehicle is decreasing;

means for determining when throttle position for said vehicle is increasing;

means for determining when manifold pressure for said vehicle is increasing;

and

means for determining when engine speed for said vehicle is decreasing;

said processor subsystem activating said downshift notification circuit if both road speed and engine speed are decreasing and both throttle position and manifold pressure for said vehicle are increasing.

28. (Original) Apparatus for optimizing operation of a vehicle, comprising:

a plurality of sensors coupled to a vehicle having an engine, said plurality of sensors, which collectively monitor operation of said vehicle, including a road speed sensor, a manifold pressure sensor and a throttle position sensor;

a processor subsystem, coupled to each one of said plurality of sensors, to receive data therefrom;

a fuel overinjection notification circuit coupled to said processor subsystem, said fuel overinjection notification circuit issuing a notification that excessive fuel is being supplied to said engine of said vehicle;

said processor subsystem determining whether to activate said fuel overinjection notification sensor based upon data received from said road speed sensor, said throttle position sensor and said manifold pressure sensor.

29. (Original) Apparatus according to claim 28 and further comprising:

a memory subsystem, coupled to said processor subsystem, said memory subsystem maintaining a manifold pressure set point;

said processor subsystem activating said fuel overinjection notification circuit upon determining that:

(1) based upon data received from said road speed sensor, road speed of said vehicle is increasing;

(2) based upon data received from said throttle position sensor, throttle position for said vehicle is increasing; and

(3) based upon data received from said manifold pressure sensor, manifold

Control No. 90013252

pressure for said vehicle exceeds said manifold pressure set point.

30. (Original) Apparatus according to claim 28, wherein:

said plurality of sensors coupled to said vehicle further include an engine speed sensor;

said processor subsystem activating said fuel overinjection notification circuit upon determining that:

(1) based upon data received from said road speed sensor, road speed of said vehicle is decreasing;

(2) based upon data received from said throttle position sensor, throttle position for said vehicle is increasing;

(3) based upon data received from said manifold pressure sensor, manifold pressure for said vehicle is increasing; and

(4) based upon data received from said engine speed sensor, engine speed for said vehicle is decreasing.

31-32. Canceled.

33. (Previously Presented) Apparatus for optimizing operation of a vehicle according to claim 1 further comprising:

means for determining a distance separating a vehicle and an object, wherein the vehicle includes an engine; and

a vehicle proximity alarm circuit coupled to said processor subsystem, wherein the vehicle proximity alarm circuit includes at least one of a visual notification and an audible notification;



wherein, upon the processor subsystem receiving the distance from said means for determining a distance and determining said distance is less than a predetermined distance, the processor subsystem activates the vehicle proximity alarm circuit.

34. (Previously Presented) Apparatus for optimizing operation of a vehicle according to claim 33, further comprising:

a throttle controller for controlling a throttle of said engine of said vehicle;

wherein, upon the processor subsystem receiving the distance from said means for determining a distance and determining said distance received is less than a predetermined distance, the processor subsystem reduces said throttle.

35. (Previously Presented) Apparatus for optimizing operation of a vehicle according to claim 33, further wherein the processor subsystem determines whether the brakes of the vehicle are activated.

36. (Previously Presented) Apparatus for optimizing operation of a vehicle according to claim 33, wherein the vehicle proximity alarm circuit further comprises a display for displaying at least one of the speed of the object, and the distance to the object.

37. (Previously Presented) Apparatus for optimizing operation of a vehicle according to claim 34, wherein the processor subsystem includes (i) an active mode wherein the processor subsystem activates an alarm and reduces the throttle based upon the distance received from said means for determining, and (ii) an inactive mode wherein the processor subsystem activates an alarm and the processor

Control No. 90013252

subsystem does not reduce the throttle based upon the distance received from said means for determining.

38. (Previously Presented) Apparatus for optimizing operation of a vehicle according to claim 37, further comprising a means for mode selection between said active mode and said inactive mode.

39. (Previously Presented) Apparatus for optimizing operation of a vehicle according to claim 1, wherein said plurality of sensors is the engine speed sensor and the vehicle speed sensor.

40. (Previously Presented) Apparatus for optimizing operation of a vehicle according to claim 1, wherein said notification that the engine is being operated an excessive speed comprises an automatic corrective action by the vehicle.

41. (Previously Presented) Apparatus for optimizing operation of a vehicle according to claim 1, wherein said notification that the engine is being operated at an excessive speed notifies a driver that an upshift should be performed.

42. (Previously Presented) Apparatus for optimizing operation of a vehicle according to claim 1, wherein said notification that excessive fuel is being supplied to said engine of said vehicle notifies a driver that the vehicle is not being operated fuel efficiently.

43. (Previously Presented) Apparatus for optimizing operation of a vehicle according to claim 1, wherein said manifold pressure set point is a manifold pressure threshold value.

44. (Previously Presented) Apparatus for optimizing operation of a vehicle according to claim 1, wherein said manifold pressure set point is a threshold value above which the manifold pressure should not exceed.

45. (Previously Presented) Apparatus for optimizing operation of a vehicle according to claim 1, wherein said processor subsystem determines when to activate said fuel overinjection circuit and said upshift notification circuit based upon said manifold pressure set point and said RPM set point.

46. (Previously Presented) Apparatus for optimizing operation of a vehicle according to claim 1, wherein said determination to activate said fuel overinjection circuit is based on data from the road speed sensor.

47. (Previously Presented) Apparatus for optimizing operation of a vehicle according to claim 1, wherein said determination to activate said fuel overinjection circuit is based on data from the manifold pressure sensor.

48. (Previously Presented) Apparatus for optimizing operation of a vehicle according to claim 1, wherein said determination to activate said fuel overinjection circuit is based on data from the throttle position sensor.

49. (Previously Presented) Apparatus for optimizing operation of a vehicle according to claim 1, wherein said processor subsystem is configured to automatically power on when the vehicle is started.

50. (Previously Presented) Apparatus for optimizing operation of a vehicle according to claim 1, wherein said determination when to activate said fuel overinjection circuit and said determination when to activate said upshift

notification circuit is based upon said present and prior levels for said plurality of sensors stored in said memory subsystem.

51. (Previously Presented) Apparatus for optimizing operation of a vehicle according to claim 1, wherein said processor subsystem is configured to periodically communicate with said plurality of sensors.

52. (Previously Presented) Apparatus for optimizing operation of a vehicle according to claim 1, wherein said processor subsystem is configured to retrieve data from the plurality of sensors and store the data in said memory subsystem.

53. (Previously Presented) Apparatus for optimizing operation of a vehicle according to claim 17, wherein the processor subsystem includes (i) an active mode wherein the processor subsystem activates an alarm and reduces the throttle based upon a distance received from said radar detector, and (ii) an inactive mode wherein the processor subsystem activates an alarm and the processor subsystem does not reduce the throttle based upon a distance received from said radar detector.

54. (Previously Presented) Apparatus for optimizing operation of a vehicle according to claim 53, further comprising a means for mode selection between said active mode and said inactive mode.

55. (Previously Presented) Apparatus for optimizing operation of a vehicle according to claim 17, wherein said processor subsystem activates said upshift notification circuit based on the manifold pressure set point and RPM set point.

56. (Previously Presented) Apparatus for optimizing operation of a vehicle according to claim 17, wherein said at least one sensor is the road speed sensor.

Control No. 90013252

57. (Previously Presented) Apparatus for optimizing operation of a vehicle according to claim 17, wherein the first speed/stopping distance table is based on National Safety Council guidelines.

58. (Previously Presented) Apparatus for optimizing operation of a vehicle according to claim 17, further wherein said processor subsystem automatically applies the brakes based upon data received from said radar detector, said at least one sensor and said memory subsystem.

59. (Previously Presented) Apparatus for optimizing operation of a vehicle according to claim 28 further comprising:

a means for determining a distance separating a vehicle and an object, wherein the vehicle includes an engine; and

a vehicle proximity alarm circuit coupled to said processor subsystem;

wherein said processor subsystem activates said vehicle proximity alarm circuit based at least upon the data received from said road speed sensor, and the means for determining the distance separating the vehicle and the object.

61-84. (Canceled)

85. (New) Apparatus for optimizing operation of a vehicle, comprising:

a radar detector, said radar detector determining a distance separating a vehicle having an engine and an object in front of said vehicle;

a plurality of sensors coupled to said vehicle for monitoring operation thereof, said [at least one] plurality of sensors including a road speed sensor and an engine speed sensor;

a processor subsystem, coupled to said radar detector and said at least one

Control No. 90013252

sensor, to receive data therefrom;

a memory subsystem, coupled to said processor subsystem, said memory subsystem storing a first vehicle speed/stopping distance table;

a vehicle proximity alarm circuit coupled to said processor subsystem, said vehicle proximity alarm circuit issuing an alarm that said vehicle is too close to said object;

said processor subsystem determining whether to activate said vehicle proximity alarm circuit based upon separation distance data received from said radar detector, vehicle speed data received from said road speed sensor and said first vehicle speed/stopping distance table stored in said memory subsystem; and

a throttle controller for controlling a throttle of said engine of said vehicle;

wherein said processor subsystem selectively reduces said throttle based upon the data received from said radar detector;

further wherein the processor subsystem includes (i) an active mode in which the processor subsystem activates the vehicle proximity alarm circuit to issue the vehicle proximity alarm and reduces the throttle based upon the data received from said radar detector, and (ii) an inactive mode in which the processor subsystem activates the vehicle proximity alarm circuit to issue the alarm and the throttle is not selectively reduced based upon the data received from said radar detector;

a fuel overinjection notification circuit coupled to said processor subsystem, said fuel overinjection notification circuit issuing a notification that excessive fuel is being supplied to said engine of said vehicle;

Control No. 90013252

wherein said processor subsystem determines whether to activate said fuel overinjection notification circuit based upon at least the data received from said road speed sensor.

86. (New) Apparatus for optimizing operation of a vehicle, comprising:

a tachometer;

a radar detector, said radar detector determining a distance separating a vehicle having an engine and an object in front of said vehicle;

a plurality of sensors coupled to said vehicle for monitoring operation thereof, said [at least one] plurality of sensors including a road speed sensor, an engine speed sensor and a brake sensor;

a processor subsystem, coupled to said radar detector and said at least one sensor, to receive data therefrom;

a memory subsystem including random access memory, coupled to said processor subsystem, said memory subsystem storing a first vehicle speed/stopping distance table;

a vehicle proximity alarm circuit coupled to said processor subsystem, said vehicle proximity alarm circuit issuing an alarm that said vehicle is too close to said object;

said processor subsystem determining whether to activate said vehicle proximity alarm circuit based upon separation distance data received from said radar detector, vehicle speed data received from said road speed sensor and said first vehicle speed/stopping distance table stored in said memory subsystem;

a throttle controller for controlling a throttle of said engine of said vehicle;

wherein said processor subsystem selectively reduces said throttle based upon the data received from said radar detector;

further wherein the processor subsystem includes (i) an active mode in which the processor subsystem activates the vehicle proximity alarm circuit to issue the vehicle proximity alarm and reduces the throttle based upon the data received from said radar detector, and (ii) an inactive mode in which the processor subsystem activates the vehicle proximity alarm circuit to issue the alarm and the throttle is not selectively reduced based upon the data received from said radar detector;

an upshift notification circuit coupled to said processor subsystem.

87. (New) Apparatus for optimizing operation of a vehicle, comprising:

a radar detector, said radar detector determining a distance separating a vehicle having an engine and an object in front of said vehicle;

a plurality of sensors coupled to said vehicle for monitoring operation thereof, said [at least one] plurality of sensors including a road speed sensor, an engine speed sensor and a brake sensor;

a processor subsystem, coupled to said radar detector and said at least one sensor, to receive data therefrom;

a memory subsystem, coupled to said processor subsystem, said memory subsystem storing a first vehicle speed/stopping distance table and an RPM set point;

a vehicle proximity alarm circuit coupled to said processor subsystem, said vehicle proximity alarm circuit issuing an alarm that said vehicle is too close to said



Control No. 90013252

object;

said processor subsystem determining whether to activate said vehicle proximity alarm circuit based upon separation distance data received from said radar detector, vehicle speed data received from said road speed sensor and said first vehicle speed/stopping distance table stored in said memory subsystem;

a throttle controller for controlling a throttle of said engine of said vehicle;

wherein said processor subsystem selectively reduces said throttle based upon the data received from said radar detector;

further wherein the processor subsystem includes (i) an active mode in which the processor subsystem activates the vehicle proximity alarm circuit to issue the vehicle proximity alarm and reduces the throttle based upon the data received from said radar detector, and (ii) an inactive mode in which the processor subsystem activates the vehicle proximity alarm circuit to issue the alarm and the throttle is not selectively reduced based upon the data received from said radar detector;

further wherein said processor subsystem determines whether a brake of the vehicle is activated based upon data received from the brake sensor.

87. (New) Apparatus for optimizing operation of a vehicle according to claim 85, further comprising:

a display;

wherein the vehicle proximity alarm includes at least one of an audible and a visual indication; and

wherein the visual indication is displayed on the display.

88. (New) Apparatus for optimizing operation of a vehicle according to claim 87, further comprising means for mode selection between said active mode and said inactive mode.

89. (New) Apparatus for optimizing operation of a vehicle according to claim 88, further comprising an upshift notification circuit coupled to said processor subsystem, said upshift notification circuit issuing a a notification that said engine of said vehicle is being operated at an excessive speed.

90. (New) Apparatus for optimizing operation of a vehicle according to claim 89, further comprising a downshift notification circuit coupled to said processor subsystem, said downshift notification circuit issuing a notification that said engine of said vehicle is being operated at an insufficient engine speed.

91. (New) Apparatus for optimizing operation of a vehicle according to claim 88, further comprising a selector for selecting a type of vehicle proximity alarm, wherein the type of vehicle proximity alarm is selected from the group consisting of an audible indication, a visual indication, and combinations thereof.

92. (New) Apparatus for optimizing operation of a vehicle according to claim 85, wherein said first speed/stopping distance table is a lookup table.

93. (New) Apparatus for optimizing operation of a vehicle according to claim 85, wherein said first speed/stopping distance table is based upon National Safety Council guidelines.

94. (New) Apparatus for optimizing operation of a vehicle according to claim 88, further comprising a bus for bidirectional exchanges of address, data and control signals between said processor subsystem and said memory subsystem.

95. (New) Apparatus for optimizing operation of a vehicle according to claim 94, wherein said memory subsystem includes at least one register for holding the level of said road speed sensor.

96. (New) Apparatus for optimizing operation of a vehicle according to claim 88, further comprising a speedometer.

97. (New) Apparatus for optimizing operation of a vehicle according to claim 85, wherein said vehicle comprises a truck.

98. (New) Apparatus for optimizing operation of a vehicle according to claim 88, further comprising a power source including voltage divider circuitry.

99. (New) Apparatus for optimizing operation of a vehicle according to claim 85, wherein said memory subsystem stores vehicle class information.

100. (New) Apparatus for optimizing operation of a vehicle according to claim 85, wherein said processor subsystem is configured to automatically power on when the vehicle is started.

101. (New) Apparatus for optimizing operation of a vehicle according to claim 88, wherein said processor subsystem is configured to retrieve data from said road speed sensor and store the data in said memory subsystem.

102. (New) Apparatus for optimizing operation of a vehicle according to claim 88, wherein said processor subsystem is configured to wait a preselected time period after issuing the vehicle proximity alarm.

103. (New) Apparatus for optimizing operation of a vehicle according to claim 88, wherein said processor subsystem is configured to select a type of vehicle proximity alarm based on the determined distance, wherein the type of vehicle

proximity alarm is selected from the group consisting of an audible indication, a visual indication, and combinations thereof.

104. (New) Apparatus for optimizing operation of a vehicle according to claim 85, wherein said first speed/stopping distance table is the relationship between vehicle speed and stopping distance.

105. (New) Apparatus for optimizing operation of a vehicle according to claim 85 wherein:

said plurality of sensors further including a windshield wiper sensor for indicating whether a windshield wiper of said vehicle is activated; and

said memory subsystem further storing a second vehicle speed/stopping distance table;

if said windshield wiper sensor indicates that said windshield wiper is deactivated, said processor subsystem determining whether to activate said vehicle proximity alarm circuit based upon data received from said radar detector, said road speed sensor and said first vehicle speed/stopping distance table stored in said memory subsystem;

if said windshield wiper sensor indicates that said windshield wiper is activated, said processor subsystem determining whether to activate said vehicle proximity alarm circuit based upon data received from said radar detector, said road speed sensor and said second vehicle speed/stopping distance table stored in said memory subsystem.

106. (New) Apparatus for optimizing operation of a vehicle according to claim 86, further comprising means for mode selection between said active mode

and said inactive mode.

107. (New) Apparatus for optimizing operation of a vehicle according to claim 106, further comprising:

a display;

wherein the vehicle proximity alarm includes at least one of an audible and a visual indication; and

wherein the visual indication is displayed on the display.

108. (New) Apparatus for optimizing operation of a vehicle according to claim 107, further comprising a selector for selecting a type of vehicle proximity alarm, wherein the type of vehicle proximity alarm is selected from the group consisting of an audible indication, a visual indication, and combinations thereof.

109. (New) Apparatus for optimizing operation of a vehicle according to claim 86, wherein said processor subsystem tracks the number of vehicle proximity alarms issued before corrective action eliminates a hazardous condition.

110. (New) Apparatus for optimizing operation of a vehicle according to claim 108, wherein said memory subsystem stores vehicle class information.

111. (New) Apparatus for optimizing operation of a vehicle according to claim 108, wherein said processor subsystem is configured to select a type of vehicle proximity alarm based on the determined distance, wherein the type of vehicle proximity alarm is selected from the group consisting of an audible indication, a visual indication, and combinations thereof.

112. (New) Apparatus for optimizing operation of a vehicle according to claim 111, further comprising a fuel overinjection notification circuit coupled to said

Control No. 90013252

processor subsystem, said fuel overinjection notification circuit issuing a notification that excessive fuel is being supplied to said engine of said vehicle.

113. (New) Apparatus for optimizing operation of a vehicle according to claim 87, further comprising:

an upshift notification circuit coupled to said processor subsystem, said upshift notification circuit issuing a notification that said engine of said vehicle is being operated at an excessive speed; and

said processor subsystem determining, based upon whether engine speed exceeds said RPM set point, when to activate said upshift notification circuit.

114 (New) Apparatus for optimizing operation of a vehicle according to claim 87, further comprising a selector for selecting a type of vehicle proximity alarm, wherein the type of vehicle proximity alarm is selected from the group consisting of an audible indication, a visual indication, and combinations thereof.

**Remarks**

This Supplemental Response is being submitted to supplement the claim amendments submitted in the Response dated November 10, 2014.

Specifically, the present Supplemental Response is being submitted to identify a Statutory Disclaimer of claims 31 and 32, and enter new independent claims 85-87 and dependent claims 88-114. Dependent application claims 60-84, which were previously presented and depended from claim 31, have also been cancelled for the sake of simplicity given the presentation of new claims 85-87 (and dependent claims 88-114). Patent Owner believes that dependent claims 60-84 were patentable, but, in the interest of expediting prosecution, has presented new dependent claims 88-114. In short, because claims 31 and 32 have been canceled here, the Examiner's rejections of claims 31 and 32 as anticipated by Davidian or rendered obvious by Davidian combined with Tonkin are now moot.

New independent claims 85-87 share common elements with disclaimed claim 31 (previously presented). Accordingly, the new independent claims do not enlarge the scope of the claims in the patent. To the contrary, in addition to the elements of claim 31, these new claims add several elements not found in the prior art the Examiner cited as anticipating or rendering obvious disclaimed claims 31 and 32 respectively. New independent claims 85-87 are thus narrower in scope than disclaimed claim 31. In particular, elements not found in the cited prior art are at least the following:

**Claim 85**

- “an engine speed sensor”;

- “a throttle controller for controlling a throttle of said engine of said vehicle”;
- “wherein said processor subsystem selectively reduces said throttle based upon data received from said radar detector”;
- “further wherein the processor subsystem includes (i) an active mode in which the processor subsystem activates the vehicle proximity alarm circuit to issue the vehicle proximity alarm and reduces the throttle based upon the data received from said radar detector, and (ii) an inactive mode in which the processor subsystem activates the vehicle proximity alarm circuit to issue the alarm and the throttle is not selectively reduced based upon the data received from said radar detector;”
- “a fuel overinjection notification circuit coupled to said processor subsystem, said fuel overinjection notification circuit issuing a notification that excessive fuel is being supplied to said engine of said vehicle”; and
- “wherein said processor subsystem determines whether to activate said fuel overinjection notification circuit based upon at least the data received from said road speed sensor.”

**Claim 86**

- “a tachometer”;
- “an engine speed sensor”;
- “a throttle controller for controlling a throttle of said engine of said vehicle”;
- “wherein said processor subsystem selectively reduces said throttle based upon the data received from said radar detector”;
- “further wherein the processor subsystem includes (i) an active mode in which the processor subsystem activates the vehicle proximity alarm circuit to issue the vehicle proximity alarm and reduces the throttle based upon the data received from said radar detector, and (ii) an inactive mode in which the processor subsystem activates the vehicle proximity alarm circuit to issue the alarm and the throttle is not selectively reduced based upon the data received from said radar detector;” and
- “an upshift notification circuit coupled to said processor subsystem.”

**Claim 87**

- “an engine speed sensor”;
- “a brake sensor”
- “an RPM set point”;
- “a throttle controller for controlling a throttle of said engine of said vehicle”;
- “wherein said processor subsystem selectively reduces said throttle based upon the data received from said radar detector”;
- “further wherein the processor subsystem includes (i) an active mode in which the processor subsystem activates the vehicle proximity alarm circuit to issue the vehicle proximity alarm and reduces the throttle based upon the data received from said radar detector, and (ii) an inactive mode in which the



processor subsystem activates the vehicle proximity alarm circuit to issue the alarm and the throttle is not selectively reduced based upon the data received from said radar detector;” and

- “wherein said processor subsystem determines whether a brake of the vehicle is activated based upon data received from the brake sensor.”

As previously discussed, Patent Owner believes that independent claim 31 and dependent claim 32 are patentably distinct over the prior art of record. However, Patent Owner is involved in litigations against three automobile manufacturers, each of which is currently stayed until this reexamination concludes. In an effort to expedite the reexamination so that the stay may be lifted promptly, Patent Owner has presented new independent claims 85-87 to unquestionably distinguish the prior art cited by Requester under the provisions of 35 U.S.C. § 301. New claims 88-106, which depend from independent claim 85, claims 107-112, which depend from independent claim 86, and claims 113-114, which dependent from independent claim 87, recite further limitations, making them patentably distinct from the prior art cited by Requester under the provisions of 35 U.S.C. § 301 at least for the reasons identified above.

Moreover, as discussed previously, because new claims 33-59 dependent from confirmed patentable claims 1, 17 or 28, new dependent claims 33-59 are also patentable. Again, while Patent Owner believes that the allowed claims are patentable over the prior art of record, out of an abundance of caution, Patent Owner has submitted new dependent claims 33-59 to further distinguish the prior art cited by the Requester under the provisions of 35 U.S.C. § 301. Patent Owner respectfully submits that all the claims in the application are in condition for allowance.

Control No. 90013252

No new matter has been added by the amendments and new claims presented herein. The Patent Owner respectfully requests reconsideration and reexamination of the claims in light of the present amendments and remarks contained within the Response dated November 3, 2014.

Finally, the Statutory Disclaimer pursuant to 35 U.S.C. § 253 recorded by the Patent Owner does not constitute an admission or acquiescence by the Patent Owner with regard to the Examiner's rejection or positions take by the Requester. As identified above, Patent Owner makes the Statutory Disclaimer solely in the interest of mooted the outstanding rejection and expediting this reexamination such that the litigation stay may be lifted promptly. Patent Owner disagrees with the Requester's arguments and makes the present disclaimer without prejudice to the Patent Owner's ability to rebut characterizations of, for example, prior art references in another forum.

#### **Notice of Related Litigation**

Pursuant to its ongoing duty, Patent Owner notifies the Examiner of two petitions requesting inter partes review of certain claims of U.S. Patent No. 5,954,781. The case numbers for the petitions are IPR2015-00276 and IPR2015-00290.

**Conclusion**

In view of the foregoing remarks, Patent Owner submits that all of the currently pending claims are in allowable form and that the application is in condition for allowance. Therefore, Patent Owner respectfully requests that a timely Reexamination Certificate confirming the present claims be issued in this case. If for any reason the Examiner is unable to issue a Reexamination Certificate confirming the present claims the application and feels that an interview would be helpful to resolve any remaining issues, the Examiner is requested to contact the undersigned attorney at (312) 283-8555.

Respectfully submitted,

RICHARDS PATENT LAW PC



Patrick D. Richards  
Registration. No. 48,905

**Please recognize Customer No. 88360  
as the correspondence address.**

Richards Patent Law P.C.  
233 S. Wacker Dr., 84<sup>th</sup> Floor  
Chicago, IL 60606  
Phone: (312) 283-8555  
**Date: December 10, 2014**

Control No. 90/013252

Docket No. 1089-001

**PATENT**

**IN THE UNITED STATES PATENT AND TRADEMARK OFFICE**

**Control No.** : 90013252                      **Confirmation No.** : 9999  
**Patent No.** : 5,954,781  
**Applicant** : Harvey Slepian  
**Reexam Filed:** May 22, 2014  
**Art Unit.** : 3992  
**Examiner** : David E. England  
**Customer No.:** 88360

Commissioner for Patents  
P.O. Box 1450  
Alexandria, VA 22313-1450

**STATUTORY DISCLAIMER IN PATENT UNDER 37 C.F.R. 1.321(a)**

Sir:

The Applicant hereby disclaims all of Applicant's rights in entirety of Claims 31 and 32 in the above-identified patent.

The present Statutory Disclaimer does not constitute any acquiescence by the Applicant with regard to the outstanding rejections in the pending Reexamination of the above-identified patent (Control No. 90/013252). Rather, the Applicant respectfully disagrees with all of the outstanding rejections and makes the present disclaimer without prejudice to Applicant's positions regarding the cited art references cited in those rejections.

The undersigned is the attorney of record in the above-identified Reexamination and is thus authorized to sign the Statutory Disclaimer.

Control No. 90/013252

Please charge the fee for this Disclaimer and any additional fees or credit to  
Deposit Account No. 505178.

Respectfully submitted,

RICHARDS PATENT LAW PC



Patrick D. Richards  
Registration. No. 48,905

**Please recognize Customer No. 88360  
as the correspondence address.**

Richards Patent Law P.C.  
233 S. Wacker Dr., 84<sup>th</sup> Floor  
Chicago, IL 60606  
Phone: (312) 283-8555  
**Date: December 10, 2014**

## Electronic Acknowledgement Receipt

<b>EFS ID:</b>	20919228
<b>Application Number:</b>	90013252
<b>International Application Number:</b>	
<b>Confirmation Number:</b>	9999
<b>Title of Invention:</b>	Method and Apparatus for Optimizing Vehicle Operation
<b>First Named Inventor/Applicant Name:</b>	5,954,781
<b>Customer Number:</b>	88360
<b>Filer:</b>	Patrick Duffy Richards
<b>Filer Authorized By:</b>	
<b>Attorney Docket Number:</b>	
<b>Receipt Date:</b>	10-DEC-2014
<b>Filing Date:</b>	22-MAY-2014
<b>Time Stamp:</b>	13:39:48
<b>Application Type:</b>	Reexam (Third Party)

### Payment information:

Submitted with Payment	no
------------------------	----

### File Listing:

Document Number	Document Description	File Name	File Size(Bytes)/ Message Digest	Multi Part /.zip	Pages (if appl.)
1	Supplemental Response or Supplemental Amendment	1089-001SupplementalAmendment.pdf	238397 <small>1da083dcdcbfd327768c53eb63235c7181ceef07a</small>	no	37

### Warnings:

### Information:

2	Statutory disclaimers per MPEP 1490.	1089-001StatutoryDisclaimer.pdf	61655 bc0a49b24b2bba58557e2008fa9d0fd80a047d	no	2
<b>Warnings:</b>					
<b>Information:</b>					
<b>Total Files Size (in bytes):</b>				300052	
<p><b>This Acknowledgement Receipt evidences receipt on the noted date by the USPTO of the indicated documents, characterized by the applicant, and including page counts, where applicable. It serves as evidence of receipt similar to a Post Card, as described in MPEP 503.</b></p> <p><b><u>New Applications Under 35 U.S.C. 111</u></b>  <b>If a new application is being filed and the application includes the necessary components for a filing date (see 37 CFR 1.53(b)-(d) and MPEP 506), a Filing Receipt (37 CFR 1.54) will be issued in due course and the date shown on this Acknowledgement Receipt will establish the filing date of the application.</b></p> <p><b><u>National Stage of an International Application under 35 U.S.C. 371</u></b>  <b>If a timely submission to enter the national stage of an international application is compliant with the conditions of 35 U.S.C. 371 and other applicable requirements a Form PCT/DO/EO/903 indicating acceptance of the application as a national stage submission under 35 U.S.C. 371 will be issued in addition to the Filing Receipt, in due course.</b></p> <p><b><u>New International Application Filed with the USPTO as a Receiving Office</u></b>  <b>If a new international application is being filed and the international application includes the necessary components for an international filing date (see PCT Article 11 and MPEP 1810), a Notification of the International Application Number and of the International Filing Date (Form PCT/RO/105) will be issued in due course, subject to prescriptions concerning national security, and the date shown on this Acknowledgement Receipt will establish the international filing date of the application.</b></p>					

Doc code: IDS

Doc description: Information Disclosure Statement (IDS) Filed

Under the Paperwork Reduction Act of 1995, no persons are required to respond to a collection of information unless it contains a valid OMB control number.

PTO/BB/06e (01-15)

Approved for use through 07/31/2012. OMB 0851-0031

U.S. Patent and Trademark Office; U.S. DEPARTMENT OF COMMERCE

<b>INFORMATION DISCLOSURE STATEMENT BY APPLICANT</b> ( Not for submission under 37 CFR 1.98)	Application Number	90013252
	Filing Date	2014-05-22
	First Named Inventor	HARVEY SLEPIAN
	Art Unit	3992
	Examiner Name	England, David E.
	Attorney Docket Number	1089-001

U.S. PATENTS						
Examiner Initial*	Cite No	Patent Number	Kind Code <sup>1</sup>	Issue Date	Name of Patentee or Applicant of cited Document	Pages, Columns, Lines where Relevant Passages or Relevant Figures Appear
	1					

If you wish to add additional U.S. Patent citation information please click the Add button.

U.S. PATENT APPLICATION PUBLICATIONS						
Examiner Initial*	Cite No	Publication Number	Kind Code <sup>1</sup>	Publication Date	Name of Patentee or Applicant of cited Document	Pages, Columns, Lines where Relevant Passages or Relevant Figures Appear
	1					

If you wish to add additional U.S. Published Application citation information please click the Add button.

FOREIGN PATENT DOCUMENTS								
Examiner Initial*	Cite No	Foreign Document Number <sup>3</sup>	Country Code <sup>2</sup>	Kind Code <sup>4</sup>	Publication Date	Name of Patentee or Applicant of cited Document	Pages, Columns, Lines where Relevant Passages or Relevant Figures Appear	T <sup>5</sup>
	1							<input type="checkbox"/>

If you wish to add additional Foreign Patent Document citation information please click the Add button

NON-PATENT LITERATURE DOCUMENTS			
Examiner Initials*	Cite No	Include name of the author (in CAPITAL LETTERS), title of the article (when appropriate), title of the item (book, magazine, journal, serial, symposium, catalog, etc), date, pages(s), volume-issue number(s), publisher, city and/or country where published.	T <sup>5</sup>



<b>INFORMATION DISCLOSURE STATEMENT BY APPLICANT</b> ( Not for submission under 37 CFR 1.99)	Application Number	90013252
	Filing Date	2014-05-22
	First Named Inventor	HARVEY SLEPIAN
	Art Unit	3992
	Examiner Name	England, David E.
	Attorney Docket Number	

113	IPR2015-00276, Volkswagen Group of America, Inc. (Petitioner) v. Velocity Patent, LLC (Patent Owner), United States Patent and Trademark Office, Patent Trial and Appeal Board, Filing Date November 21, 2014	<input type="checkbox"/>
114	IPR2015-00290, Mercedes-Benz USA, LLC and Mercedes-Benz U.S. International, Inc. (Petitioner) v. Velocity Patent, LLC (Patent Owner), United States Patent and Trademark Office, Patent Trial and Appeal Board, Filing Date November 21, 2014	<input type="checkbox"/>

If you wish to add additional non-patent literature document citation information please click the Add button

**EXAMINER SIGNATURE**

Examiner Signature		Date Considered	
--------------------	--	-----------------	--

\*EXAMINER: Initial if reference considered, whether or not citation is in conformance with MPEP 609. Draw line through a citation if not in conformance and not considered. Include copy of this form with next communication to applicant.

<sup>1</sup> See Kind Codes of USPTO Patent Documents at [www.USPTO.GOV](http://www.USPTO.GOV) or MPEP 901.04. <sup>2</sup> Enter office that issued the document, by the two-letter code (WIPO Standard ST.3). <sup>3</sup> For Japanese patent documents, the indication of the year of the reign of the Emperor must precede the serial number of the patent document. <sup>4</sup> Kind of document by the appropriate symbols as indicated on the document under WIPO Standard ST.16 if possible. <sup>5</sup> Applicant is to place a check mark here if English language translation is attached.

<b>INFORMATION DISCLOSURE STATEMENT BY APPLICANT</b> ( Not for submission under 37 CFR 1.99)	Application Number	90013252
	Filing Date	2014-05-22
	First Named Inventor	HARVEY SLEPIAN
	Art Unit	3992
	Examiner Name	England, David E.
	Attorney Docket Number	

**CERTIFICATION STATEMENT**

Please see 37 CFR 1.97 and 1.98 to make the appropriate selection(s):

That each item of information contained in the information disclosure statement was first cited in any communication from a foreign patent office in a counterpart foreign application not more than three months prior to the filing of the information disclosure statement. See 37 CFR 1.97(e)(1).

OR

That no item of information contained in the information disclosure statement was cited in a communication from a foreign patent office in a counterpart foreign application, and, to the knowledge of the person signing the certification after making reasonable inquiry, no item of information contained in the information disclosure statement was known to any individual designated in 37 CFR 1.56(c) more than three months prior to the filing of the information disclosure statement. See 37 CFR 1.97(e)(2).

See attached certification statement.

The fee set forth in 37 CFR 1.17 (p) has been submitted herewith.

A certification statement is not submitted herewith.

**SIGNATURE**

A signature of the applicant or representative is required in accordance with CFR 1.33, 10.18. Please see CFR 1.4(d) for the form of the signature.

Signature	/Patrick D. Richards/	Date (YYYY-MM-DD)	2014-12-10
Name/Print	Patrick Richards	Registration Number	48905

This collection of information is required by 37 CFR 1.97 and 1.98. The information is required to obtain or retain a benefit by the public which is to file (and by the USPTO to process) an application. Confidentiality is governed by 35 U.S.C. 122 and 37 CFR 1.14. This collection is estimated to take 1 hour to complete, including gathering, preparing and submitting the completed application form to the USPTO. Time will vary depending upon the individual case. Any comments on the amount of time you require to complete this form and/or suggestions for reducing this burden, should be sent to the Chief Information Officer, U.S. Patent and Trademark Office, U.S. Department of Commerce, P.O. Box 1450, Alexandria, VA 22313-1450. **DO NOT SEND FEES OR COMPLETED FORMS TO THIS ADDRESS. SEND TO: Commissioner for Patents, P.O. Box 1450, Alexandria, VA 22313-1450.**

## Privacy Act Statement

The Privacy Act of 1974 (P.L. 93-579) requires that you be given certain information in connection with your submission of the attached form related to a patent application or patent. Accordingly, pursuant to the requirements of the Act, please be advised that: (1) the general authority for the collection of this information is 35 U.S.C. 2(b)(2); (2) furnishing of the information solicited is voluntary; and (3) the principal purpose for which the information is used by the U.S. Patent and Trademark Office is to process and/or examine your submission related to a patent application or patent. If you do not furnish the requested information, the U.S. Patent and Trademark Office may not be able to process and/or examine your submission, which may result in termination of proceedings or abandonment of the application or expiration of the patent.

The information provided by you in this form will be subject to the following routine uses:

1. The information on this form will be treated confidentially to the extent allowed under the Freedom of Information Act (5 U.S.C. 552) and the Privacy Act (5 U.S.C. 552a). Records from this system of records may be disclosed to the Department of Justice to determine whether the Freedom of Information Act requires disclosure of these records.
2. A record from this system of records may be disclosed, as a routine use, in the course of presenting evidence to a court, magistrate, or administrative tribunal, including disclosures to opposing counsel in the course of settlement negotiations.
3. A record in this system of records may be disclosed, as a routine use, to a Member of Congress submitting a request involving an individual, to whom the record pertains, when the individual has requested assistance from the Member with respect to the subject matter of the record.
4. A record in this system of records may be disclosed, as a routine use, to a contractor of the Agency having need for the information in order to perform a contract. Recipients of information shall be required to comply with the requirements of the Privacy Act of 1974, as amended, pursuant to 5 U.S.C. 552a(m).
5. A record related to an International Application filed under the Patent Cooperation Treaty in this system of records may be disclosed, as a routine use, to the International Bureau of the World Intellectual Property Organization, pursuant to the Patent Cooperation Treaty.
6. A record in this system of records may be disclosed, as a routine use, to another federal agency for purposes of National Security review (35 U.S.C. 181) and for review pursuant to the Atomic Energy Act (42 U.S.C. 218(c)).
7. A record from this system of records may be disclosed, as a routine use, to the Administrator, General Services, or his/her designee, during an inspection of records conducted by GSA as part of that agency's responsibility to recommend improvements in records management practices and programs, under authority of 44 U.S.C. 2904 and 2906. Such disclosure shall be made in accordance with the GSA regulations governing inspection of records for this purpose, and any other relevant (i.e., GSA or Commerce) directive. Such disclosure shall not be used to make determinations about individuals.
8. A record from this system of records may be disclosed, as a routine use, to the public after either publication of the application pursuant to 35 U.S.C. 122(b) or issuance of a patent pursuant to 35 U.S.C. 151. Further, a record may be disclosed, subject to the limitations of 37 CFR 1.14, as a routine use, to the public if the record was filed in an application which became abandoned or in which the proceedings were terminated and which application is referenced by either a published application, an application open to public inspections or an issued patent.
9. A record from this system of records may be disclosed, as a routine use, to a Federal, State, or local law enforcement agency, if the USPTO becomes aware of a violation or potential violation of law or regulation.

## Electronic Acknowledgement Receipt

<b>EFS ID:</b>	20927975
<b>Application Number:</b>	90013252
<b>International Application Number:</b>	
<b>Confirmation Number:</b>	9999
<b>Title of Invention:</b>	Method and Apparatus for Optimizing Vehicle Operation
<b>First Named Inventor/Applicant Name:</b>	5,954,781
<b>Customer Number:</b>	88360
<b>Filer:</b>	Patrick Duffy Richards
<b>Filer Authorized By:</b>	
<b>Attorney Docket Number:</b>	
<b>Receipt Date:</b>	10-DEC-2014
<b>Filing Date:</b>	22-MAY-2014
<b>Time Stamp:</b>	22:27:54
<b>Application Type:</b>	Reexam (Third Party)

### Payment information:

Submitted with Payment	no
------------------------	----

### File Listing:

Document Number	Document Description	File Name	File Size(Bytes)/ Message Digest	Multi Part /.zip	Pages (if appl.)
1	Other Reference-Patent/App/Search documents	Ex1001-US5954781.pdf	1913270 <small>bfee69e69e2b595d26b7839ef916026e4cb1370d</small>	no	15

### Warnings:

### Information:

2	Other Reference-Patent/App/Search documents	Ex1002-AutomotiveElectronicHandbook.pdf	16673998 0805d24c01499a1721c5a3073e23f16a68a9b4	no	226
<b>Warnings:</b>					
<b>Information:</b>					
3	Other Reference-Patent/App/Search documents	Ex1003-US4398174.pdf	1081505 a82f4c7eb7e3e8ce72be52fd91e14d9ed0143740	no	7
<b>Warnings:</b>					
<b>Information:</b>					
4	Other Reference-Patent/App/Search documents	Ex1004-US4559599.pdf	1317885 28511681c4c7c9475f5fb25e6ddd9c22d337b030	no	10
<b>Warnings:</b>					
<b>Information:</b>					
5	Other Reference-Patent/App/Search documents	Ex1005-US5357438.pdf	2518956 6214c60f014148d00be30b1f3d82e52fcd66f9d	no	41
<b>Warnings:</b>					
<b>Information:</b>					
6	Other Reference-Patent/App/Search documents	Ex1006-WO9692853.pdf	2657222 5fa5a2de2fd69ca3de1759e9398bee0ec41561e8	no	43
<b>Warnings:</b>					
<b>Information:</b>					
7	Other Reference-Patent/App/Search documents	Ex1008-Part3RequestforExParteReexam90013252.pdf	20842464 3d7ba8a4ff0151e7be0e7aa87d3e355819c47637	no	125
<b>Warnings:</b>					
<b>Information:</b>					
8	Other Reference-Patent/App/Search documents	Ex1008-Part4RequestforExParteReexam90013252.pdf	23968346 6bad3b367d6a7deb511b3c5ccff6db1e392afb47	no	130
<b>Warnings:</b>					
<b>Information:</b>					
9	Other Reference-Patent/App/Search documents	Ex1008-Part5RequestforExParteReexam90013252.pdf	17893203 d9d8868375688b653c3033f28017acecfe208343	no	201
<b>Warnings:</b>					
<b>Information:</b>					
10	Other Reference-Patent/App/Search documents	Ex1007-August61998OfficeActioninUSPatentApp08813270.pdf	703730 1fd17f2d4c30256d3a6118791e4eecd70aa10d23	no	9
<b>Warnings:</b>					
<b>Information:</b>					

11	Other Reference-Patent/App/Search documents	Ex1008-PartIRequestforExParteReexam90013252.pdf	21744791 26c110c2f34230d7d66251841a6c44bed374b647	no	175
<b>Warnings:</b>					
<b>Information:</b>					
12	Other Reference-Patent/App/Search documents	Ex1008-PartIRequestforExParteReexam90013252.pdf	23400974 894d67b5c91038043b2523182607aa98d1df09be	no	700
<b>Warnings:</b>					
<b>Information:</b>					
13	Other Reference-Patent/App/Search documents	Ex1009-DecisionGrantinginExParteReexamination90013252.pdf	1881278 dfc6298fc3b8a91dcb8e9bcd07fa945909985b	no	35
<b>Warnings:</b>					
<b>Information:</b>					
14	Other Reference-Patent/App/Search documents	Ex1011-October212014OfficeActioninExParteReexamination90013252.pdf	3216255 67cd60ebc672809fb3e725f90240efa732d48af8	no	60
<b>Warnings:</b>					
<b>Information:</b>					
15	Other Reference-Patent/App/Search documents	Ex1012-ResponseinExParteReexamination90013252.pdf	1843755 3723adfc0d8a350fe61a8b291e09e04bdecbe089	no	37
<b>Warnings:</b>					
<b>Information:</b>					
16	Other Reference-Patent/App/Search documents	Ex1010-PetitionforIPR2014-01247.pdf	1370963 0b675dd08d06a37ed248b980f039e04f7c6e64a6	no	57
<b>Warnings:</b>					
<b>Information:</b>					
17	Other Reference-Patent/App/Search documents	PowerofAttorney.pdf	417592 53ea626aab33607233d7c4c7b006c1ff4a28e709	no	3
<b>Warnings:</b>					
<b>Information:</b>					
18	Other Reference-Patent/App/Search documents	VolkswagenGroupIPRPetition.pdf	413094 37090c294a7ff0c07a56a51234dda986cb11bd3	no	65
<b>Warnings:</b>					
<b>Information:</b>					
19	Other Reference-Patent/App/Search documents	20141202NoticeofFilingDateAccordedtoPetition.pdf	590446 e0ba9c28a176b18d56dd4d89df0f6c1247a11b5	no	1
<b>Warnings:</b>					
<b>Information:</b>					

20	Information Disclosure Statement (IDS) Form (SB08)	IDS.pdf	1171206 <small>70b5d845a42e4eb59e9dc537776a2221d65d445</small>	no	4
<b>Warnings:</b>					
<b>Information:</b>					
This is not an USPTO supplied IDS fillable form					
<b>Total Files Size (in bytes):</b>			145620933		
<p><b>This Acknowledgement Receipt evidences receipt on the noted date by the USPTO of the indicated documents, characterized by the applicant, and including page counts, where applicable. It serves as evidence of receipt similar to a Post Card, as described in MPEP 503.</b></p> <p><b><u>New Applications Under 35 U.S.C. 111</u></b>  <b>If a new application is being filed and the application includes the necessary components for a filing date (see 37 CFR 1.53(b)-(d) and MPEP 506), a Filing Receipt (37 CFR 1.54) will be issued in due course and the date shown on this Acknowledgement Receipt will establish the filing date of the application.</b></p> <p><b><u>National Stage of an International Application under 35 U.S.C. 371</u></b>  <b>If a timely submission to enter the national stage of an international application is compliant with the conditions of 35 U.S.C. 371 and other applicable requirements a Form PCT/DO/EO/903 indicating acceptance of the application as a national stage submission under 35 U.S.C. 371 will be issued in addition to the Filing Receipt, in due course.</b></p> <p><b><u>New International Application Filed with the USPTO as a Receiving Office</u></b>  <b>If a new international application is being filed and the international application includes the necessary components for an international filing date (see PCT Article 11 and MPEP 1810), a Notification of the International Application Number and of the International Filing Date (Form PCT/RO/105) will be issued in due course, subject to prescriptions concerning national security, and the date shown on this Acknowledgement Receipt will establish the international filing date of the application.</b></p>					

**IN THE UNITED STATES PATENT AND TRADEMARK OFFICE**

In Re Patent of : Harvey SLEPIAN, et al.  
Patent No. : 5,954,781  
Issued : Sep. 21, 1999  
Reexamination Control No. : 90/013,252  
Title : METHOD AND APPARATUS FOR OPTIMIZING  
VEHICLE OPERATION  
Examiner : David E. England  
Requester : Volkswagen Group of America, Inc.  
Confirmation No. : 9999

**VIA EFS-WEB**

Mail Stop *Ex Parte* Reexamination  
Commissioner for Patents  
P.O. Box 1450  
Alexandria, Virginia 22313-1450

I hereby certify that this correspondence is being electronically transmitted to the United States Patent and Trademark Office via the Office electronic filing system on **November 24, 2014**.

Signature: /Samantha Chan/  
Samantha Chan

**NOTIFICATION OF CONCURRENT PROCEEDINGS**

Pursuant to the statement contained, for example, on pages 29 to 30 of the Order dated June 27, 2014 (“The third party requester is also reminded of the ability to similarly apprise the Office of any such activity or proceeding throughout the course of this reexamination proceeding. See MPEP §§ 2207, 2282 and 2686”), Requester, Volkswagen Group of America, Inc. (“VWGoA”), notifies the Office of the following proceedings in which the patent under reexamination, U.S. Patent No. 5,954,781, is involved:

1. *Inter Partes* Review Case No. IPR2015-00290 -- Petition, attached as Exhibit 1, filed on November 21, 2014, and Declaration of Dr. Chris G. Bartone, P.E., attached as Exhibit 2, filed on November 21, 2014 by Mercedes-Benz USA, LLC and Mercedes-Benz U.S. International, Inc.



As required pursuant to 37 C.F.R. § 1.550(f), a copy of this paper is being served on the patent owner by first class mail in the manner provided in 37 C.F.R. § 1.248 on the date stated in the Certificate of Service annexed hereto.

Respectfully submitted,

Date: November 24, 2014

By: /Clifford A. Ulrich/  
Clifford A. Ulrich  
Reg. No. 42,194

KENYON & KENYON LLP  
One Broadway  
New York, New York 10004  
(212) 425-7200 (telephone)  
(212) 425-5288 (facsimile)  
CUSTOMER NO. 26646

Attorney for Requester,  
VOLKSWAGEN GROUP OF  
AMERICA, INC.

**IN THE UNITED STATES PATENT AND TRADEMARK OFFICE**

In Re Patent of : Harvey SLEPIAN, et al.  
Patent No. : 5,954,781  
Issued : Sep. 21, 1999  
Reexamination Control No. : 90/013,252  
Title : METHOD AND APPARATUS FOR OPTIMIZING  
VEHICLE OPERATION  
Examiner : David E. England  
Requester : Volkswagen Group of America, Inc.  
Confirmation No. : 9999

**VIA EFS-WEB**

Mail Stop *Ex Parte* Reexamination  
Commissioner for Patents  
P.O. Box 1450  
Alexandria, Virginia 22313-1450

**CERTIFICATE OF SERVICE**

I hereby certify that the attached "NOTIFICATION OF CONCURRENT PROCEEDINGS" is being served in its entirety by first class mail on the patent owner in this reexamination proceeding at the address listed below in the manner provided for in 37 C.F.R. § 1.248:

Richards Patent Law P.C.  
233 S. Wacker Dr., 84th Floor  
Chicago, Illinois 60606

on this 24th day of November 2014.

/Clifford A. Ulrich/  
Clifford A. Ulrich  
Reg. No. 42,194

KENYON & KENYON LLP  
One Broadway  
New York, New York 10004  
(212) 425-7200 (telephone)  
(212) 425-5288 (facsimile)  
CUSTOMER NO. 26646

Attorney for Requester,  
VOLKSWAGEN GROUP OF  
AMERICA, INC.

## Electronic Acknowledgement Receipt

<b>EFS ID:</b>	20786166
<b>Application Number:</b>	90013252
<b>International Application Number:</b>	
<b>Confirmation Number:</b>	9999
<b>Title of Invention:</b>	Method and Apparatus for Optimizing Vehicle Operation
<b>First Named Inventor/Applicant Name:</b>	5,954,781
<b>Customer Number:</b>	88360
<b>Filer:</b>	Clifford A. Ulrich/Samantha Chan
<b>Filer Authorized By:</b>	Clifford A. Ulrich
<b>Attorney Docket Number:</b>	
<b>Receipt Date:</b>	24-NOV-2014
<b>Filing Date:</b>	22-MAY-2014
<b>Time Stamp:</b>	17:09:06
<b>Application Type:</b>	Reexam (Third Party)

### Payment information:

Submitted with Payment	no
------------------------	----

### File Listing:

Document Number	Document Description	File Name	File Size(Bytes)/ Message Digest	Multi Part /.zip	Pages (if appl.)
1	Notice of concurrent proceeding(s)	2014-11-24-Notice-of-Concurrent-Proceedings.pdf	89689 dd9dbc8936d7eedadef7ded44db8cd589a7e296e	no	2

### Warnings:

### Information:

2	Reexam Certificate of Service	2014-11-24-Certificate-of-Service.pdf	79671 d853183f977115d30be4ea3fbac031a5e1378d90	no	1
<b>Warnings:</b>					
<b>Information:</b>					
3	Reexam - Affidavit/Decl/Exhibit Filed by 3rd Party	Ex-1-MBUSA-IPR2015-00290-Petition.pdf	360560 b7b35b6857b4b56530cf1046ae1da81f33d96251	no	65
<b>Warnings:</b>					
<b>Information:</b>					
4	Reexam - Affidavit/Decl/Exhibit Filed by 3rd Party	Ex-2-Declaration-of-Bartone.pdf	908014 6cea975985bdba01bb01ecf734f15c927809b327	no	86
<b>Warnings:</b>					
<b>Information:</b>					
<b>Total Files Size (in bytes):</b>				1437934	
<p><b>This Acknowledgement Receipt evidences receipt on the noted date by the USPTO of the indicated documents, characterized by the applicant, and including page counts, where applicable. It serves as evidence of receipt similar to a Post Card, as described in MPEP 503.</b></p> <p><b><u>New Applications Under 35 U.S.C. 111</u></b>  If a new application is being filed and the application includes the necessary components for a filing date (see 37 CFR 1.53(b)-(d) and MPEP 506), a Filing Receipt (37 CFR 1.54) will be issued in due course and the date shown on this Acknowledgement Receipt will establish the filing date of the application.</p> <p><b><u>National Stage of an International Application under 35 U.S.C. 371</u></b>  If a timely submission to enter the national stage of an international application is compliant with the conditions of 35 U.S.C. 371 and other applicable requirements a Form PCT/DO/EO/903 indicating acceptance of the application as a national stage submission under 35 U.S.C. 371 will be issued in addition to the Filing Receipt, in due course.</p> <p><b><u>New International Application Filed with the USPTO as a Receiving Office</u></b>  If a new international application is being filed and the international application includes the necessary components for an international filing date (see PCT Article 11 and MPEP 1810), a Notification of the International Application Number and of the International Filing Date (Form PCT/RO/105) will be issued in due course, subject to prescriptions concerning national security, and the date shown on this Acknowledgement Receipt will establish the international filing date of the application.</p>					

Docket No. 1089-001

**PATENT**

**IN THE UNITED STATES PATENT AND TRADEMARK OFFICE**

**Control No.** : 90013252                      **Confirmation No.** : 9999  
**Patent No.** : 5,954,781  
**Applicant** : Harvey Slepian  
**Reexam Filed:** May 22, 2014  
**Art Unit.** : 3992  
**Examiner** : David E. England  
**Customer No.:** 88360

Commissioner for Patents  
P.O. Box 1450  
Alexandria, VA 22313-1450

**RESPONSE**

Sir:

This Supplemental Response is being submitted in the above-identified Reexamination. Please amend the above-identified application as follows:

**Amendments to the Claims** are reflected in the listing of claims, which begins on page 2 of this paper.

**Remarks/Arguments** begin on page 29 of this paper.

### **Amendments to the Claims**

This listing of claims will replace all prior versions, and listings, of claims in the application:

#### **Listing of Claims**

1. (Original) Apparatus for optimizing operation of a vehicle, comprising:

a plurality of sensors coupled to a vehicle having an engine, said plurality of sensors, which collectively monitor operation of said vehicle, including a road speed sensor, an engine speed sensor, a manifold pressure sensor and a throttle position sensor;

a processor subsystem, coupled to each one of said plurality of sensors, to receive data therefrom;

a memory subsystem, coupled to said processor subsystem, said memory subsystem storing therein a manifold pressure set point, an RPM set point, and present and prior levels for each one of said plurality of sensors;

a fuel overinjection notification circuit coupled to said processor subsystem, said fuel overinjection notification circuit issuing a notification that excessive fuel is being supplied to said engine of said vehicle;

an upshift notification circuit coupled to said processor subsystem, said upshift notification circuit issuing a notification that said engine of said vehicle is being operated at an excessive speed;

said processor subsystem determining, based upon data received from said plurality of sensors, when to activate said fuel overinjection circuit and when to activate said upshift notification circuit.

2. (Original) Apparatus for optimizing operation of a vehicle according to claim 1 wherein said processor subsystem further comprises:

means for determining when road speed for said vehicle is increasing;

means for determining when throttle position for said vehicle is increasing;

and

means for comparing manifold pressure to said manifold pressure set point;

said processor subsystem activating said fuel overinjection notification circuit if both road speed and throttle position for said vehicle are increasing and manifold pressure for said vehicle is above said manifold pressure set point.

3. (Original) Apparatus for optimizing operation of a vehicle according to claim 1 wherein said fuel overinjection circuit further comprises a horn for issuing a tone for a preselected time period.

4. (Original) Apparatus for optimizing operation of a vehicle according to claim 1 wherein said processor subsystem further comprises:

means for determining when road speed for said vehicle is decreasing;

means for determining when throttle position for said vehicle is increasing;

means for determining when manifold pressure for said vehicle is increasing;

and

means for determining when engine speed for said vehicle is decreasing;

said processor subsystem activating said fuel overinjection notification

Control No. 90013252

circuit if both throttle position and manifold pressure for said vehicle are increasing and road speed and engine speed for said vehicle are decreasing.

5. (Original) Apparatus for optimizing operation of a vehicle according to claim 1 wherein said processor subsystem further comprises:

means for determining when road speed for said vehicle is increasing;

means for determining when throttle position for said vehicle is increasing;

means for comparing manifold pressure to said manifold pressure set point;

and

means for comparing engine speed to said RPM set point;

said processor subsystem activating said upshift notification circuit if both road speed and throttle position for said vehicle are increasing, manifold pressure for said vehicle is at or below said manifold pressure set point and engine speed for said vehicle is at or above said RPM set point.

6. (Original) Apparatus for optimizing operation of a vehicle according to claim 1 wherein said upshift notification circuit further comprises a horn for issuing a tone for a preselected time period.

7. (Original) Apparatus for optimizing operation of a vehicle, comprising:

a plurality of sensors coupled to a vehicle having an engine, said plurality of sensors, which collectively monitor operation of said vehicle, including a road speed sensor, a manifold pressure sensor and a throttle position sensor;



Control No. 90013252

a processor subsystem, coupled to each one of said plurality of sensors, to receive data therefrom;

a memory subsystem, coupled to said processor subsystem, said memory subsystem storing therein a manifold pressure set point and present and prior levels for each one of said plurality of sensors;

a fuel overinjection notification circuit coupled to said processor subsystem, said fuel overinjection notification circuit issuing a notification that excessive fuel is being supplied to said engine of said vehicle;

a downshift notification circuit coupled to said processor subsystem, said downshift notification circuit issuing a notification that said engine of said vehicle is being operated at an insufficient engine speed; and

said processor subsystem determining, based upon data received from said plurality of sensors, when to activate said fuel overinjection circuit and when to activate said downshift notification circuit.

8. (Original) Apparatus for optimizing operation of a vehicle according to claim 7 wherein said processor subsystem further comprises:

means for determining when road speed for said vehicle is increasing;

means for determining when throttle position for said vehicle is increasing;

and

means for comparing manifold pressure to said manifold pressure set point;

said processor subsystem activating said fuel overinjection notification circuit if both road speed and throttle position for said vehicle are increasing and

Control No. 90013252

manifold pressure for said vehicle is above said manifold pressure set point.

9. (Original) Apparatus for optimizing operation of a vehicle according to claim 7 wherein said fuel overinjection circuit further comprises a horn for issuing a tone for a preselected time period.

10. (Original) Apparatus for optimizing operation of a vehicle according to claim 7 wherein said processor subsystem further comprises:

means for determining when road speed for said vehicle is decreasing;

means for determining when throttle position for said vehicle is increasing;

means for determining when manifold pressure for said vehicle is increasing;

and

means for determining when engine speed for said vehicle is decreasing;

said processor subsystem activating said downshift notification circuit if both road speed and engine speed are decreasing and both throttle position and manifold pressure for said vehicle are increasing.

11. (Original) Apparatus for optimizing operation of a vehicle according to claim 10 wherein said downshift notification circuit further comprises a horn for issuing a tone for a preselected time period.

12. (Original) Apparatus for optimizing operation of a vehicle according to claim 7 wherein said processor subsystem further comprises:

Control No. 90013252

means for determining when road speed for said vehicle is decreasing;

means for determining when throttle position for said vehicle is increasing;

means for determining when manifold pressure for said vehicle is increasing;

and

means for determining when engine speed for said vehicle is decreasing;

said processor subsystem activating said fuel overinjection notification circuit if both throttle position and manifold pressure for said vehicle are increasing and road speed and engine speed for said vehicle are decreasing.

13. (Original) Apparatus for optimizing operation of a vehicle, comprising:

a plurality of sensors coupled to a vehicle having an engine, said plurality of sensors, which collectively monitor operation of said vehicle, including a road speed sensor, an engine speed sensor, a manifold pressure sensor and a throttle position sensor;

a processor subsystem, coupled to each one of said plurality of sensors, to receive data therefrom;

a memory subsystem, coupled to said processor subsystem, said memory subsystem storing therein a manifold pressure set point, an engine speed set point and present and prior levels for each one of said plurality of sensors;

a fuel overinjection notification circuit coupled to said processor subsystem, said fuel overinjection notification circuit issuing a notification that excessive fuel is being supplied to said engine of said vehicle;

an upshift notification circuit coupled to said processor subsystem, said

Control No. 90013252

upshift notification circuit issuing a notification that said engine of said vehicle is being operated at an excessive engine speed;

a downshift notification circuit coupled to said processor subsystem, said downshift notification circuit issuing a notification that said engine of said vehicle is being operated at an insufficient engine speed;

said processor subsystem determining, based upon data received from said plurality of sensors, when to activate said fuel overinjection circuit, said upshift notification circuit and said downshift notification circuit.

14. (Original) Apparatus for optimizing operation of a vehicle according to claim 13 wherein:

said fuel overinjection circuit further comprises a first horn for issuing a first tone for a first preselected time period;

said upshift notification circuit further comprises a second horn for issuing a second tone for a second preselected time period; and

said downshift notification circuit further comprises a third horn for issuing a third tone for a third preselected time period.

15. (Original) Apparatus for optimizing vehicle performance according to claim 13 wherein said processor subsystem further comprises:

means for determining when road speed for said vehicle is increasing or decreasing

means for determining when throttle position for said vehicle is increasing;

Control No. 90013252

means for comparing manifold pressure to said manifold pressure set point;

means for comparing engine speed to said RPM set point;

means for determining when manifold pressure is increasing; and

means for determining when engine speed is increasing or decreasing;

said processor subsystem activating said fuel overinjection notification circuit if both road speed and throttle position for said vehicle are increasing and manifold pressure for said vehicle is above said manifold pressure set or if both throttle position and manifold pressure for said vehicle are increasing and road speed and engine speed for said vehicle are decreasing;

said processor subsystem activating said upshift notification circuit if both road speed and throttle position for said vehicle are increasing, manifold pressure for said vehicle is at or below said manifold pressure set point and engine speed for said vehicle is at or above said RPM set point; and

said processor subsystem activating said downshift notification circuit if both road speed and engine speed are decreasing and both throttle position and manifold pressure for said vehicle are increasing.

16. (Original) Apparatus for optimizing operation of a vehicle according to claim 15 wherein:

said fuel overinjection circuit further comprises a first horn for issuing a first tone for a first preselected time period;

said upshift notification circuit further comprises a second horn for issuing a second tone for a second preselected time period; and

said downshift notification circuit further comprises a third horn for issuing a third tone for a third preselected time period.

17. (Original) Apparatus for optimizing operation of a vehicle, comprising:

a radar detector, said radar detector determining a distance separating a vehicle having an engine and an object in front of said vehicle;

at least one sensor coupled to said vehicle for monitoring operation thereof, said at least one sensor including a road speed sensor, a manifold pressure sensor, a throttle position sensor and an engine speed sensor;

a processor subsystem, coupled to said radar detector and said at least one sensor, to receive data therefrom;

a memory subsystem, coupled to said processor subsystem, said memory subsystem storing a first vehicle speed/stopping distance table, a manifold pressure set point, an RPM set point, a present level for each one of said at least one sensor and a prior level for each one of said at least one sensor;

a vehicle proximity alarm circuit coupled to said processor subsystem, said vehicle proximity alarm circuit issuing an alarm that said vehicle is too close to said object;

a fuel overinjection circuit coupled to said processor subsystem, said fuel overinjection circuit issuing a notification that excessive fuel is being supplied to said engine of said vehicle;

an upshift notification circuit coupled to said processor subsystem, said upshift notification circuit issuing a notification that said engine of said vehicle is

Control No. 90013252

being operated at an excessive speed;

said processor subsystem determining, based upon data received from said radar detector, said at least one sensor and said memory subsystem, when to activate said vehicle proximity alarm circuit, when to activate said fuel overinjection circuit, and when to activate said upshift notification circuit.

18. (Original) Apparatus for optimizing operation of a vehicle according to claim 17 wherein:

said at least one sensor further includes a windshield wiper sensor for indicating whether a windshield wiper of said vehicle is activated; and

said memory subsystem further storing a second vehicle speed/stopping distance table.

19. (Original) Apparatus for optimizing operation of a vehicle according to claim 17 and further comprising:

a throttle controller for controlling a throttle of said engine of said vehicle; and

said processor subsystem selectively reducing said throttle based upon data received from said radar detector, said at least one sensor and said memory subsystem.

20. (Original) Apparatus for optimizing operation of a vehicle according to claim 19 wherein said at least one sensor further includes a brake sensor for indicating

Control No. 90013252

whether a brake system of said vehicle is activated.

21. (Original) Apparatus for optimizing operation of a vehicle according to claim 19 wherein said processor subsystem further comprises:

means for counting a total number of vehicle proximity alarms determined by said processor subsystem;

means for selectively reducing said throttle based upon said total number of vehicle proximity alarms.

22. (Original) Apparatus for optimizing operation of a vehicle according to claim 17 and further comprising:

a downshift notification circuit coupled to said processor subsystem, said downshift notification circuit issuing a notification that said engine of said vehicle is being operated at an insufficient engine speed; and

said processor subsystem determining, based upon data received from said plurality of sensors, when to activate said downshift notification circuit.

23. (Original) Apparatus for optimizing operation of a vehicle, comprising:

a radar detector, said radar detector determining a distance separating a vehicle having an engine and an object in front of said vehicle;

a plurality of sensors coupled to a vehicle having an engine, said plurality of sensors, which collectively monitor operation of said vehicle, including a road speed sensor, and engine speed sensor, a manifold pressure sensor and a throttle position



Control No. 90013252

sensor;

a processor subsystem, coupled to said radar detector and each one of said plurality of sensors, to receive data therefrom;

a memory subsystem, coupled to said processor subsystem, said memory subsystem storing therein a first vehicle speed/stopping distance table, a manifold pressure set point, an RPM set point, and present and prior levels for each one of said plurality of sensors;

a fuel overinjection notification circuit coupled to said processor subsystem, said fuel overinjection notification circuit issuing a notification that excessive fuel is being supplied to said engine of said vehicle;

an upshift notification circuit coupled to said processor subsystem, said upshift notification circuit issuing a notification that said engine of said vehicle is being operated at an excessive engine speed;

said processor subsystem determining, based upon data received from said plurality of sensors, when to activate said fuel overinjection circuit and when to activate said upshift notification circuit;

a vehicle proximity alarm circuit coupled to said processor subsystem, said vehicle proximity alarm circuit issuing an alarm that said vehicle is too close to said object;

said processor subsystem determining, based upon data received from said radar detector, said at least one sensor and said memory subsystem, when to activate said vehicle proximity alarm circuit.

Control No. 90013252

24. (Original) Apparatus for optimizing operation of a vehicle according to claim 23 wherein said processor subsystem further comprises:

means for determining when road speed for said vehicle is increasing or decreasing;

means for determining when throttle position for said vehicle is increasing or decreasing; and

means for comparing manifold pressure to said manifold pressure set point;

means for determining when manifold pressure for said vehicle is increasing or decreasing; and

means for determining when engine speed for said vehicle is increasing or decreasing;

said processor subsystem activating said fuel overinjection notification circuit if both road speed and throttle position for said vehicle are increasing and manifold pressure for said vehicle is above said manifold pressure set point or if both throttle position and manifold pressure for said vehicle are increasing and road speed and engine speed for said vehicle are decreasing.

25. (Original) Apparatus for optimizing operation of a vehicle according to claim 23 wherein said processor subsystem further comprises:

means for determining when road speed for said vehicle is increasing;

means for determining when throttle position for said vehicle is increasing;

means for comparing manifold pressure to said manifold pressure set point;

and

means for comparing engine speed to said RPM set point;

said processor subsystem activating said upshift notification circuit if both road speed and throttle position for said vehicle are increasing, manifold pressure for said vehicle is at or below said manifold pressure set point and engine speed for said vehicle is at or above said RPM set point.

26. (Original) Apparatus for optimizing operation of a vehicle, comprising:

a radar detector, said radar detector determining a distance separating a vehicle having an engine and an object in front of said vehicle;

a plurality of sensors coupled to a vehicle having an engine, said plurality of sensors, which collectively monitor operation of said vehicle, including a road speed sensor, and engine speed sensor, a manifold pressure sensor and a throttle position sensor;

a processor subsystem, coupled to said radar detector and each one of said plurality of sensors, to receive data therefrom;

a memory subsystem, coupled to said processor subsystem, said memory subsystem storing therein a first vehicle speed/stopping distance table, a manifold pressure set point, RPM set point, and present and prior levels for each one of said plurality of sensors;

a fuel overinjection notification circuit coupled to said processor subsystem, said fuel overinjection notification circuit issuing a notification that excessive fuel is being supplied to said engine of said vehicle;

a downshift notification circuit coupled to said processor subsystem, said

Control No. 90013252

downshift notification circuit issuing a notification that said engine of said vehicle is being operated at an insufficient engine speed;

said processor subsystem determining, based upon data received from said plurality of sensors, when to activate said fuel overinjection circuit and when to activate said downshift notification circuit;

a vehicle proximity alarm circuit coupled to said processor subsystem, said vehicle proximity alarm circuit issuing an alarm that said vehicle is too close to said object;

said processor subsystem determining, based upon data received from said radar detector, said at least one sensor and said memory subsystem, when to activate said vehicle proximity alarm circuit.

27. (Original) Apparatus for optimizing operation of a vehicle according to claim 26 wherein said processor subsystem further comprises:

means for determining when road speed for said vehicle is decreasing;

means for determining when throttle position for said vehicle is increasing;

means for determining when manifold pressure for said vehicle is increasing;

and

means for determining when engine speed for said vehicle is decreasing;

said processor subsystem activating said downshift notification circuit if both road speed and engine speed are decreasing and both throttle position and manifold pressure for said vehicle are increasing.

28. (Original) Apparatus for optimizing operation of a vehicle, comprising:

a plurality of sensors coupled to a vehicle having an engine, said plurality of sensors, which collectively monitor operation of said vehicle, including a road speed sensor, a manifold pressure sensor and a throttle position sensor;

a processor subsystem, coupled to each one of said plurality of sensors, to receive data therefrom;

a fuel overinjection notification circuit coupled to said processor subsystem, said fuel overinjection notification circuit issuing a notification that excessive fuel is being supplied to said engine of said vehicle;

said processor subsystem determining whether to activate said fuel overinjection notification sensor based upon data received from said road speed sensor, said throttle position sensor and said manifold pressure sensor.

29. (Original) Apparatus according to claim 28 and further comprising:

a memory subsystem, coupled to said processor subsystem, said memory subsystem maintaining a manifold pressure set point;

said processor subsystem activating said fuel overinjection notification circuit upon determining that:

(1) based upon data received from said road speed sensor, road speed of said vehicle is increasing;

(2) based upon data received from said throttle position sensor, throttle position for said vehicle is increasing; and

(3) based upon data received from said manifold pressure sensor, manifold

Control No. 90013252

pressure for said vehicle exceeds said manifold pressure set point.

30. (Original) Apparatus according to claim 28, wherein:

said plurality of sensors coupled to said vehicle further include an engine speed sensor;

said processor subsystem activating said fuel overinjection notification circuit upon determining that:

(1) based upon data received from said road speed sensor, road speed of said vehicle is decreasing;

(2) based upon data received from said throttle position sensor, throttle position for said vehicle is increasing;

(3) based upon data received from said manifold pressure sensor, manifold pressure for said vehicle is increasing; and

(4) based upon data received from said engine speed sensor, engine speed for said vehicle is decreasing.

31. (Amended) Apparatus for optimizing operation of a vehicle, comprising:

a radar detector, said radar detector determining a distance separating a vehicle having an engine and an object in front of said vehicle;

[at least one] a plurality of sensors coupled to said vehicle for monitoring operation thereof, said [at least one] plurality of sensors including a road speed sensor and an engine speed sensor;

a processor subsystem, coupled to said radar detector and said at least one sensor, to receive data therefrom;

Control No. 90013252

a memory subsystem, coupled to said processor subsystem, said memory subsystem storing a first vehicle speed/stopping distance table;

a vehicle proximity alarm circuit coupled to said processor subsystem, said vehicle proximity alarm circuit issuing an alarm that said vehicle is too close to said object;

said processor subsystem determining whether to activate said vehicle proximity alarm circuit based upon separation distance data received from said radar detector, vehicle speed data received from said road speed sensor and said first vehicle speed/stopping distance table stored in said memory subsystem; and

a throttle controller for controlling a throttle of said engine of said vehicle;

wherein said processor subsystem selectively reduces said throttle based upon the data received from said radar detector;

further wherein the processor subsystem includes (i) an active mode in which the processor subsystem activates the vehicle proximity alarm circuit to issue the vehicle proximity alarm and reduces the throttle based upon the data received from said radar detector, and (ii) an inactive mode in which the processor subsystem activates the vehicle proximity alarm circuit to issue the alarm and the throttle is not selectively reduced based upon the data received from said radar detector.

32. (Original) Apparatus for optimizing operation of a vehicle according to claim 31 wherein:

said at least one sensor further includes a windshield wiper sensor for indicating whether a windshield wiper of said vehicle is activated; and

Control No. 90013252

said memory subsystem further storing a second vehicle speed/stopping distance table;

if said windshield wiper sensor indicates that said windshield wiper is deactivated, said processor subsystem determining whether to activate said vehicle proximity alarm circuit based upon data received from said radar detector, said road speed sensor and said first vehicle speed/stopping distance table stored in said memory subsystem;

if said windshield wiper sensor indicates that said windshield wiper is activated, said processor subsystem determining whether to activate said vehicle proximity alarm circuit based upon data received from said radar detector, said road speed sensor and said second vehicle speed/stopping distance table stored in said memory subsystem.

33. (New) Apparatus for optimizing operation of a vehicle according to claim 1 further comprising:

means for determining a distance separating a vehicle and an object, wherein the vehicle includes an engine; and

a vehicle proximity alarm circuit coupled to said processor subsystem, wherein the vehicle proximity alarm circuit includes at least one of a visual notification and an audible notification;

wherein, upon the processor subsystem receiving the distance from said means for determining a distance and determining said distance is less than a predetermined distance, the processor subsystem activates the vehicle proximity alarm circuit.



34. (New) Apparatus for optimizing operation of a vehicle according to claim 33, further comprising:

a throttle controller for controlling a throttle of said engine of said vehicle;

wherein, upon the processor subsystem receiving the distance from said means for determining a distance and determining said distance received is less than a predetermined distance, the processor subsystem reduces said throttle.

35. (New) Apparatus for optimizing operation of a vehicle according to claim 33, further wherein the processor subsystem determines whether the brakes of the vehicle are activated.

36. (New) Apparatus for optimizing operation of a vehicle according to claim 33, wherein the vehicle proximity alarm circuit further comprises a display for displaying at least one of the speed of the object, and the distance to the object.

37. (New) Apparatus for optimizing operation of a vehicle according to claim 34, wherein the processor subsystem includes (i) an active mode wherein the processor subsystem activates an alarm and reduces the throttle based upon the distance received from said means for determining, and (ii) an inactive mode wherein the processor subsystem activates an alarm and the processor subsystem does not reduce the throttle based upon the distance received from said means for determining.

38. (New) Apparatus for optimizing operation of a vehicle according to claim 37, further comprising a means for mode selection between said active mode and said inactive mode.

39. (New) Apparatus for optimizing operation of a vehicle according to claim 1, wherein said plurality of sensors is the engine speed sensor and the vehicle speed sensor.
40. (New) Apparatus for optimizing operation of a vehicle according to claim 1, wherein said notification that the engine is being operated an excessive speed comprises an automatic corrective action by the vehicle.
41. (New) Apparatus for optimizing operation of a vehicle according to claim 1, wherein said notification that the engine is being operated at an excessive speed notifies a driver that an upshift should be performed.
42. (New) Apparatus for optimizing operation of a vehicle according to claim 1, wherein said notification that excessive fuel is being supplied to said engine of said vehicle notifies a driver that the vehicle is not being operated fuel efficiently.
43. (New) Apparatus for optimizing operation of a vehicle according to claim 1, wherein said manifold pressure set point is a manifold pressure threshold value.
44. (New) Apparatus for optimizing operation of a vehicle according to claim 1, wherein said manifold pressure set point is a threshold value above which the manifold pressure should not exceed.
45. (New) Apparatus for optimizing operation of a vehicle according to claim 1, wherein said processor subsystem determines when to activate said fuel overinjection circuit and said upshift notification circuit based upon said manifold pressure set point and said RPM set point.

46. (New) Apparatus for optimizing operation of a vehicle according to claim 1, wherein said determination to activate said fuel overinjection circuit is based on data from the road speed sensor.

47. (New) Apparatus for optimizing operation of a vehicle according to claim 1, wherein said determination to activate said fuel overinjection circuit is based on data from the manifold pressure sensor.

48. (New) Apparatus for optimizing operation of a vehicle according to claim 1, wherein said determination to activate said fuel overinjection circuit is based on data from the throttle position sensor.

49. (New) Apparatus for optimizing operation of a vehicle according to claim 1, wherein said processor subsystem is configured to automatically power on when the vehicle is started.

50. (New) Apparatus for optimizing operation of a vehicle according to claim 1, wherein said determination when to activate said fuel overinjection circuit and said determination when to activate said upshift notification circuit is based upon said present and prior levels for said plurality of sensors stored in said memory subsystem.

51. (New) Apparatus for optimizing operation of a vehicle according to claim 1, wherein said processor subsystem is configured to periodically communicate with said plurality of sensors.

52. (New) Apparatus for optimizing operation of a vehicle according to claim 1, wherein said processor subsystem is configured to retrieve data from the plurality of sensors and store the data in said memory subsystem.

53. (New) Apparatus for optimizing operation of a vehicle according to claim 17, wherein the processor subsystem includes (i) an active mode wherein the processor subsystem activates an alarm and reduces the throttle based upon a distance received from said radar detector, and (ii) an inactive mode wherein the processor subsystem activates an alarm and the processor subsystem does not reduce the throttle based upon a distance received from said radar detector.

54. (New) Apparatus for optimizing operation of a vehicle according to claim 53, further comprising a means for mode selection between said active mode and said inactive mode.

55. (New) Apparatus for optimizing operation of a vehicle according to claim 17, wherein said processor subsystem activates said upshift notification circuit based on the manifold pressure set point and RPM set point.

56. (New) Apparatus for optimizing operation of a vehicle according to claim 17, wherein said at least one sensor is the road speed sensor.

57. (New) Apparatus for optimizing operation of a vehicle according to claim 17, wherein the first speed/stopping distance table is based on National Safety Council guidelines.

58. (New) Apparatus for optimizing operation of a vehicle according to claim 17, further wherein said processor subsystem automatically applies the brakes based upon data received from said radar detector, said at least one sensor and said memory subsystem.

59. (New) Apparatus for optimizing operation of a vehicle according to claim 28 further comprising:

Control No. 90013252

a means for determining a distance separating a vehicle and an object, wherein the vehicle includes an engine; and

a vehicle proximity alarm circuit coupled to said processor subsystem;

wherein said processor subsystem activates said vehicle proximity alarm circuit based at least upon the data received from said road speed sensor, and the means for determining the distance separating the vehicle and the object.

60. (New) Apparatus for optimizing operation of a vehicle according to claim 31, further comprising:

a fuel overinjection notification circuit coupled to said processor subsystem, said fuel overinjection notification circuit issuing a notification that excessive fuel is being supplied to said engine of said vehicle;

wherein said processor subsystem determines whether to activate said fuel overinjection notification circuit based upon at least the data received from said road speed sensor.

61. (New) Apparatus for optimizing operation of a vehicle according to claim 31, further comprising:

a display;

wherein the vehicle proximity alarm includes at least one of an audible indication, and a visual indication; and

wherein the visual indication is displayed on the display.

62. (New) Apparatus for optimizing operation of a vehicle according to claim 31, further comprising means for mode selection between said active mode and said inactive mode.

Control No. 90013252

63. (New) Apparatus for optimizing operation of a vehicle according to claim 31, further comprising a selector for selecting a type of vehicle proximity alarm, wherein the type of vehicle proximity alarm is selected from the group consisting of an audible indication, a visual indication, and combinations thereof.

64. (New) Apparatus for optimizing operation of a vehicle according to claim 31, wherein said first speed/stopping distance table is a lookup table.

65. (New) Apparatus for optimizing operation of a vehicle according to claim 65, wherein said first speed/stopping distance table is based upon National Safety Council guidelines.

66. (New) Apparatus for optimizing operation of a vehicle according to claim 31, further comprising an upshift notification circuit coupled to said processor subsystem.

67. (New) Apparatus for optimizing operation of a vehicle according to claim 31, further wherein said processor subsystem determines whether the brakes of the vehicle are activated.

68. (New) Apparatus for optimizing operation of a vehicle according to claim 31, further comprising a bus for bidirectional exchanges of address, data and control signals between said processor subsystem and said memory subsystem.

69. (New) Apparatus for optimizing operation of a vehicle according to claim 31, wherein said memory subsystem includes at least one register for holding the level of said road speed sensor.

70. (New) Apparatus for optimizing operation of a vehicle according to claim 31, further comprising a tachometer.

Control No. 90013252

71. (New) Apparatus for optimizing operation of a vehicle according to claim 70, further comprising a speedometer.
72. (New) Apparatus of optimizing operation of a vehicle according to claim 31, wherein said vehicle comprises a truck.
73. (New) Apparatus for optimizing operation of a vehicle according to claim 31, further comprising a power source including voltage divider circuitry.
74. (New) Apparatus for optimizing operation of a vehicle according to claim 31, wherein said memory subsystem stores vehicle class information.
75. (New) Apparatus for optimizing operation of a vehicle according to claim 31, wherein said processor subsystem is configured to automatically power on when the vehicle is started.
76. (New) Apparatus for optimizing operation of a vehicle according to claim 31, wherein said processor subsystem is configured to periodically communicate with said road speed sensor.
77. (New) Apparatus for optimizing operation of a vehicle according to claim 31, wherein said processor subsystem is configured to retrieve data from said road speed sensor and store the data in said memory subsystem.
78. (New) Apparatus for optimizing operation of a vehicle according to claim 31, wherein said processor subsystem is configured to wait a preselected time period after issuing the vehicle proximity alarm.
79. (New) Apparatus for optimizing operation of a vehicle according to claim 31, wherein said processor subsystem is configured to select a type of vehicle proximity alarm based on the determined distance, wherein the type of vehicle proximity

alarm is selected from the group consisting of an audible indication, a visual indication, and combinations thereof.

80. (New) Apparatus for optimizing operation of a vehicle according to claim 31, wherein said first speed/stopping distance table is the relationship between vehicle speed and stopping distance.

81. (New) Apparatus for optimizing operation of a vehicle according to claim 71, further comprising a fuel overinjection notification circuit coupled to said processor subsystem, said fuel overinjection notification circuit issuing a notification that excessive fuel is being supplied to said engine of said vehicle.

82. (New) Apparatus for optimizing operation of a vehicle according to claim 71, further comprising an upshift notification circuit coupled to said processor subsystem.

83. (New) Apparatus for optimizing operation of a vehicle according to claim 71, wherein said vehicle proximity alarm includes an audible indication and a visual indication.

84. (New) Apparatus for optimizing operation of a vehicle according to claim 71, further comprising means for mode selection between said active mode and said inactive mode.



Control No. 90013252

**Remarks**

This Supplemental Response is being submitted to correct the form of the claim amendments submitted in the Response dated November 3, 2014. No new matter has been added by the amendments and new claims presented herein. Reconsideration and reexamination of the claims in light of the following remarks contained with in the Response dated November 3, 2014.

**Conclusion**

In view of the foregoing remarks, Patent Owner submits that all of the currently pending claims are in allowable form and that the application is in condition for allowance. Therefore, Patent Owner respectfully requests that a timely Notice of Allowance be issued in this case. If for any reason the Examiner is unable to allow the application and feels that an interview would be helpful to resolve any remaining issues, the Examiner is requested to contact the undersigned attorney at (312) 283-8555.

Respectfully submitted,

RICHARDS PATENT LAW PC



Patrick D. Richards  
Registration. No. 48,905

**Please recognize Customer No. 88360  
as the correspondence address.**

Richards Patent Law P.C.  
233 S. Wacker Dr., 84<sup>th</sup> Floor  
Chicago, IL 60606  
Phone: (312) 283-8555  
**Date: November 10, 2014**

## Electronic Acknowledgement Receipt

<b>EFS ID:</b>	20658841
<b>Application Number:</b>	90013252
<b>International Application Number:</b>	
<b>Confirmation Number:</b>	9999
<b>Title of Invention:</b>	Method and Apparatus for Optimizing Vehicle Operation
<b>First Named Inventor/Applicant Name:</b>	5,954,781
<b>Customer Number:</b>	88360
<b>Filer:</b>	Patrick Duffy Richards
<b>Filer Authorized By:</b>	
<b>Attorney Docket Number:</b>	
<b>Receipt Date:</b>	10-NOV-2014
<b>Filing Date:</b>	22-MAY-2014
<b>Time Stamp:</b>	23:14:48
<b>Application Type:</b>	Reexam (Third Party)

### Payment information:

Submitted with Payment	no
------------------------	----

### File Listing:

Document Number	Document Description	File Name	File Size(Bytes)/ Message Digest	Multi Part /.zip	Pages (if appl.)
1	Amendment/Req. Reconsideration-After Non-Final Reject	1089SupplementalResponse.pdf	191059 <small>80fa729e593888108c1a3f19c26f5a468c30218b</small>	no	30

### Warnings:

### Information:

This Acknowledgement Receipt evidences receipt on the noted date by the USPTO of the indicated documents, characterized by the applicant, and including page counts, where applicable. It serves as evidence of receipt similar to a Post Card, as described in MPEP 503.

**New Applications Under 35 U.S.C. 111**

If a new application is being filed and the application includes the necessary components for a filing date (see 37 CFR 1.53(b)-(d) and MPEP 506), a Filing Receipt (37 CFR 1.54) will be issued in due course and the date shown on this Acknowledgement Receipt will establish the filing date of the application.

**National Stage of an International Application under 35 U.S.C. 371**

If a timely submission to enter the national stage of an international application is compliant with the conditions of 35 U.S.C. 371 and other applicable requirements a Form PCT/DO/EO/903 indicating acceptance of the application as a national stage submission under 35 U.S.C. 371 will be issued in addition to the Filing Receipt, in due course.

**New International Application Filed with the USPTO as a Receiving Office**

If a new international application is being filed and the international application includes the necessary components for an international filing date (see PCT Article 11 and MPEP 1810), a Notification of the International Application Number and of the International Filing Date (Form PCT/RO/105) will be issued in due course, subject to prescriptions concerning national security, and the date shown on this Acknowledgement Receipt will establish the international filing date of the application.

Docket No. 1089-001

**PATENT**

**IN THE UNITED STATES PATENT AND TRADEMARK OFFICE**

**Appl. No.** : 90/013,252                      **Confirmation No.** : 9999  
**Patent No.** : 5,954,781  
**Filed** : May 22, 2014  
**Art Unit.** : 3992  
**Examiner** : David E. England  
**Customer No.:** 88360

Commissioner for Patents  
P.O. Box 1450  
Alexandria, VA 22313-1450

**CERTIFICATE OF SERVICE**

I hereby certify that a copy of the Response and Supplemental IDS is being served on November 4, 2014, by Federal Express on the third party requester at the following address:

Clifford A. Ulrich  
Kenyon & Kenyon LLP  
One Broadway  
New York, NY 10004

RICHARDS PATENT LAW PC



Patrick D. Richards  
Registration. No. 48,905

Richards Patent Law P.C.  
233 S. Wacker Dr., 84<sup>th</sup> Floor  
Chicago, IL 60606  
Phone: (312) 283-8555  
**Date: November 4, 2014**

## Electronic Acknowledgement Receipt

<b>EFS ID:</b>	20625655
<b>Application Number:</b>	90013252
<b>International Application Number:</b>	
<b>Confirmation Number:</b>	9999
<b>Title of Invention:</b>	Method and Apparatus for Optimizing Vehicle Operation
<b>First Named Inventor/Applicant Name:</b>	5,954,781
<b>Customer Number:</b>	88360
<b>Filer:</b>	Patrick Duffy Richards
<b>Filer Authorized By:</b>	
<b>Attorney Docket Number:</b>	
<b>Receipt Date:</b>	06-NOV-2014
<b>Filing Date:</b>	22-MAY-2014
<b>Time Stamp:</b>	14:21:58
<b>Application Type:</b>	Reexam (Third Party)

### Payment information:

Submitted with Payment	no
------------------------	----

### File Listing:

Document Number	Document Description	File Name	File Size(Bytes)/ Message Digest	Multi Part /.zip	Pages (if appl.)
1	Reexam Certificate of Service	1089CertificateofService11-4-14.pdf	75985 <small>c66d4403f1c08e9ed3383b1d8d8484d5f2b77cb</small>	no	1

### Warnings:

### Information:

This Acknowledgement Receipt evidences receipt on the noted date by the USPTO of the indicated documents, characterized by the applicant, and including page counts, where applicable. It serves as evidence of receipt similar to a Post Card, as described in MPEP 503.

**New Applications Under 35 U.S.C. 111**

If a new application is being filed and the application includes the necessary components for a filing date (see 37 CFR 1.53(b)-(d) and MPEP 506), a Filing Receipt (37 CFR 1.54) will be issued in due course and the date shown on this Acknowledgement Receipt will establish the filing date of the application.

**National Stage of an International Application under 35 U.S.C. 371**

If a timely submission to enter the national stage of an international application is compliant with the conditions of 35 U.S.C. 371 and other applicable requirements a Form PCT/DO/EO/903 indicating acceptance of the application as a national stage submission under 35 U.S.C. 371 will be issued in addition to the Filing Receipt, in due course.

**New International Application Filed with the USPTO as a Receiving Office**

If a new international application is being filed and the international application includes the necessary components for an international filing date (see PCT Article 11 and MPEP 1810), a Notification of the International Application Number and of the International Filing Date (Form PCT/RO/105) will be issued in due course, subject to prescriptions concerning national security, and the date shown on this Acknowledgement Receipt will establish the international filing date of the application.

Docket No. 1089-001

**PATENT**

**IN THE UNITED STATES PATENT AND TRADEMARK OFFICE**

**Control No.** : 90013252                      **Confirmation No.** : 9999  
**Patent No.** : 5,954,781  
**Applicant** : Harvey Slepian  
**Reexam Filed:** May 22, 2014  
**Art Unit.** : 3992  
**Examiner** : David E. England  
**Customer No.:** 88360

Commissioner for Patents  
P.O. Box 1450  
Alexandria, VA 22313-1450

**RESPONSE**

Sir:

This Response is being submitted in the above-identified Reexamination.

Please amend the above-identified application as follows:

**Amendments to the Claims** are reflected in the listing of claims, which begins on page 2 of this paper.

**Remarks/Arguments** begin on page 29 of this paper.



### **Amendments to the Claims**

This listing of claims will replace all prior versions, and listings, of claims in the application:

#### **Listing of Claims**

1. (Original) Apparatus for optimizing operation of a vehicle, comprising:

a plurality of sensors coupled to a vehicle having an engine, said plurality of sensors, which collectively monitor operation of said vehicle, including a road speed sensor, an engine speed sensor, a manifold pressure sensor and a throttle position sensor;

a processor subsystem, coupled to each one of said plurality of sensors, to receive data therefrom;

a memory subsystem, coupled to said processor subsystem, said memory subsystem storing therein a manifold pressure set point, an RPM set point, and present and prior levels for each one of said plurality of sensors;

a fuel overinjection notification circuit coupled to said processor subsystem, said fuel overinjection notification circuit issuing a notification that excessive fuel is being supplied to said engine of said vehicle;

an upshift notification circuit coupled to said processor subsystem, said upshift notification circuit issuing a notification that said engine of said vehicle is being operated at an excessive speed;

said processor subsystem determining, based upon data received from said plurality of sensors, when to activate said fuel overinjection circuit and when to activate said upshift notification circuit.

2. (Original) Apparatus for optimizing operation of a vehicle according to claim 1 wherein said processor subsystem further comprises:

means for determining when road speed for said vehicle is increasing;

means for determining when throttle position for said vehicle is increasing;

and

means for comparing manifold pressure to said manifold pressure set point;

said processor subsystem activating said fuel overinjection notification circuit if both road speed and throttle position for said vehicle are increasing and manifold pressure for said vehicle is above said manifold pressure set point.

3. (Original) Apparatus for optimizing operation of a vehicle according to claim 1 wherein said fuel overinjection circuit further comprises a horn for issuing a tone for a preselected time period.

4. (Original) Apparatus for optimizing operation of a vehicle according to claim 1 wherein said processor subsystem further comprises:

means for determining when road speed for said vehicle is decreasing;

means for determining when throttle position for said vehicle is increasing;

means for determining when manifold pressure for said vehicle is increasing;

and

means for determining when engine speed for said vehicle is decreasing;

said processor subsystem activating said fuel overinjection notification

Control No. 90013252

circuit if both throttle position and manifold pressure for said vehicle are increasing and road speed and engine speed for said vehicle are decreasing.

5. (Original) Apparatus for optimizing operation of a vehicle according to claim 1 wherein said processor subsystem further comprises:

means for determining when road speed for said vehicle is increasing;

means for determining when throttle position for said vehicle is increasing;

means for comparing manifold pressure to said manifold pressure set point;

and

means for comparing engine speed to said RPM set point;

said processor subsystem activating said upshift notification circuit if both road speed and throttle position for said vehicle are increasing, manifold pressure for said vehicle is at or below said manifold pressure set point and engine speed for said vehicle is at or above said RPM set point.

6. (Original) Apparatus for optimizing operation of a vehicle according to claim 1 wherein said upshift notification circuit further comprises a horn for issuing a tone for a preselected time period.

7. (Original) Apparatus for optimizing operation of a vehicle, comprising:

a plurality of sensors coupled to a vehicle having an engine, said plurality of sensors, which collectively monitor operation of said vehicle, including a road speed sensor, a manifold pressure sensor and a throttle position sensor;

Control No. 90013252

a processor subsystem, coupled to each one of said plurality of sensors, to receive data therefrom;

a memory subsystem, coupled to said processor subsystem, said memory subsystem storing therein a manifold pressure set point and present and prior levels for each one of said plurality of sensors;

a fuel overinjection notification circuit coupled to said processor subsystem, said fuel overinjection notification circuit issuing a notification that excessive fuel is being supplied to said engine of said vehicle;

a downshift notification circuit coupled to said processor subsystem, said downshift notification circuit issuing a notification that said engine of said vehicle is being operated at an insufficient engine speed; and

said processor subsystem determining, based upon data received from said plurality of sensors, when to activate said fuel overinjection circuit and when to activate said downshift notification circuit.

8. (Original) Apparatus for optimizing operation of a vehicle according to claim 7 wherein said processor subsystem further comprises:

means for determining when road speed for said vehicle is increasing;

means for determining when throttle position for said vehicle is increasing;

and

means for comparing manifold pressure to said manifold pressure set point;

said processor subsystem activating said fuel overinjection notification circuit if both road speed and throttle position for said vehicle are increasing and

Control No. 90013252

manifold pressure for said vehicle is above said manifold pressure set point.

9. (Original) Apparatus for optimizing operation of a vehicle according to claim 7 wherein said fuel overinjection circuit further comprises a horn for issuing a tone for a preselected time period.

10. (Original) Apparatus for optimizing operation of a vehicle according to claim 7 wherein said processor subsystem further comprises:

means for determining when road speed for said vehicle is decreasing;

means for determining when throttle position for said vehicle is increasing;

means for determining when manifold pressure for said vehicle is increasing;

and

means for determining when engine speed for said vehicle is decreasing;

said processor subsystem activating said downshift notification circuit if both road speed and engine speed are decreasing and both throttle position and manifold pressure for said vehicle are increasing.

11. (Original) Apparatus for optimizing operation of a vehicle according to claim 10 wherein said downshift notification circuit further comprises a horn for issuing a tone for a preselected time period.

12. (Original) Apparatus for optimizing operation of a vehicle according to claim 7 wherein said processor subsystem further comprises:

Control No. 90013252

means for determining when road speed for said vehicle is decreasing;

means for determining when throttle position for said vehicle is increasing;

means for determining when manifold pressure for said vehicle is increasing;

and

means for determining when engine speed for said vehicle is decreasing;

said processor subsystem activating said fuel overinjection notification circuit if both throttle position and manifold pressure for said vehicle are increasing and road speed and engine speed for said vehicle are decreasing.

13. (Original) Apparatus for optimizing operation of a vehicle, comprising:

a plurality of sensors coupled to a vehicle having an engine, said plurality of sensors, which collectively monitor operation of said vehicle, including a road speed sensor, an engine speed sensor, a manifold pressure sensor and a throttle position sensor;

a processor subsystem, coupled to each one of said plurality of sensors, to receive data therefrom;

a memory subsystem, coupled to said processor subsystem, said memory subsystem storing therein a manifold pressure set point, an engine speed set point and present and prior levels for each one of said plurality of sensors;

a fuel overinjection notification circuit coupled to said processor subsystem, said fuel overinjection notification circuit issuing a notification that excessive fuel is being supplied to said engine of said vehicle;

an upshift notification circuit coupled to said processor subsystem, said

Control No. 90013252

upshift notification circuit issuing a notification that said engine of said vehicle is being operated at an excessive engine speed;

a downshift notification circuit coupled to said processor subsystem, said downshift notification circuit issuing a notification that said engine of said vehicle is being operated at an insufficient engine speed;

said processor subsystem determining, based upon data received from said plurality of sensors, when to activate said fuel overinjection circuit, said upshift notification circuit and said downshift notification circuit.

14. (Original) Apparatus for optimizing operation of a vehicle according to claim 13 wherein:

said fuel overinjection circuit further comprises a first horn for issuing a first tone for a first preselected time period;

said upshift notification circuit further comprises a second horn for issuing a second tone for a second preselected time period; and

said downshift notification circuit further comprises a third horn for issuing a third tone for a third preselected time period.

15. (Original) Apparatus for optimizing vehicle performance according to claim 13 wherein said processor subsystem further comprises:

means for determining when road speed for said vehicle is increasing or decreasing

means for determining when throttle position for said vehicle is increasing;

Control No. 90013252

means for comparing manifold pressure to said manifold pressure set point;

means for comparing engine speed to said RPM set point;

means for determining when manifold pressure is increasing; and

means for determining when engine speed is increasing or decreasing;

said processor subsystem activating said fuel overinjection notification circuit if both road speed and throttle position for said vehicle are increasing and manifold pressure for said vehicle is above said manifold pressure set or if both throttle position and manifold pressure for said vehicle are increasing and road speed and engine speed for said vehicle are decreasing;

said processor subsystem activating said upshift notification circuit if both road speed and throttle position for said vehicle are increasing, manifold pressure for said vehicle is at or below said manifold pressure set point and engine speed for said vehicle is at or above said RPM set point; and

said processor subsystem activating said downshift notification circuit if both road speed and engine speed are decreasing and both throttle position and manifold pressure for said vehicle are increasing.

16. (Original) Apparatus for optimizing operation of a vehicle according to claim 15 wherein:

said fuel overinjection circuit further comprises a first horn for issuing a first tone for a first preselected time period;

said upshift notification circuit further comprises a second horn for issuing a second tone for a second preselected time period; and



said downshift notification circuit further comprises a third horn for issuing a third tone for a third preselected time period.

17. (Original) Apparatus for optimizing operation of a vehicle, comprising:

a radar detector, said radar detector determining a distance separating a vehicle having an engine and an object in front of said vehicle;

at least one sensor coupled to said vehicle for monitoring operation thereof, said at least one sensor including a road speed sensor, a manifold pressure sensor, a throttle position sensor and an engine speed sensor;

a processor subsystem, coupled to said radar detector and said at least one sensor, to receive data therefrom;

a memory subsystem, coupled to said processor subsystem, said memory subsystem storing a first vehicle speed/stopping distance table, a manifold pressure set point, an RPM set point, a present level for each one of said at least one sensor and a prior level for each one of said at least one sensor;

a vehicle proximity alarm circuit coupled to said processor subsystem, said vehicle proximity alarm circuit issuing an alarm that said vehicle is too close to said object;

a fuel overinjection circuit coupled to said processor subsystem, said fuel overinjection circuit issuing a notification that excessive fuel is being supplied to said engine of said vehicle;

an upshift notification circuit coupled to said processor subsystem, said upshift notification circuit issuing a notification that said engine of said vehicle is

Control No. 90013252

being operated at an excessive speed;

said processor subsystem determining, based upon data received from said radar detector, said at least one sensor and said memory subsystem, when to activate said vehicle proximity alarm circuit, when to activate said fuel overinjection circuit, and when to activate said upshift notification circuit.

18. (Original) Apparatus for optimizing operation of a vehicle according to claim 17 wherein:

said at least one sensor further includes a windshield wiper sensor for indicating whether a windshield wiper of said vehicle is activated; and

said memory subsystem further storing a second vehicle speed/stopping distance table.

19. (Original) Apparatus for optimizing operation of a vehicle according to claim 17 and further comprising:

a throttle controller for controlling a throttle of said engine of said vehicle; and

said processor subsystem selectively reducing said throttle based upon data received from said radar detector, said at least one sensor and said memory subsystem.

20. (Original) Apparatus for optimizing operation of a vehicle according to claim 19 wherein said at least one sensor further includes a brake sensor for indicating

Control No. 90013252

whether a brake system of said vehicle is activated.

21. (Original) Apparatus for optimizing operation of a vehicle according to claim 19 wherein said processor subsystem further comprises:

means for counting a total number of vehicle proximity alarms determined by said processor subsystem;

means for selectively reducing said throttle based upon said total number of vehicle proximity alarms.

22. (Original) Apparatus for optimizing operation of a vehicle according to claim 17 and further comprising:

a downshift notification circuit coupled to said processor subsystem, said downshift notification circuit issuing a notification that said engine of said vehicle is being operated at an insufficient engine speed; and

said processor subsystem determining, based upon data received from said plurality of sensors, when to activate said downshift notification circuit.

23. (Original) Apparatus for optimizing operation of a vehicle, comprising:

a radar detector, said radar detector determining a distance separating a vehicle having an engine and an object in front of said vehicle;

a plurality of sensors coupled to a vehicle having an engine, said plurality of sensors, which collectively monitor operation of said vehicle, including a road speed sensor, and engine speed sensor, a manifold pressure sensor and a throttle position

Control No. 90013252

sensor;

a processor subsystem, coupled to said radar detector and each one of said plurality of sensors, to receive data therefrom;

a memory subsystem, coupled to said processor subsystem, said memory subsystem storing therein a first vehicle speed/stopping distance table, a manifold pressure set point, an RPM set point, and present and prior levels for each one of said plurality of sensors;

a fuel overinjection notification circuit coupled to said processor subsystem, said fuel overinjection notification circuit issuing a notification that excessive fuel is being supplied to said engine of said vehicle;

an upshift notification circuit coupled to said processor subsystem, said upshift notification circuit issuing a notification that said engine of said vehicle is being operated at an excessive engine speed;

said processor subsystem determining, based upon data received from said plurality of sensors, when to activate said fuel overinjection circuit and when to activate said upshift notification circuit;

a vehicle proximity alarm circuit coupled to said processor subsystem, said vehicle proximity alarm circuit issuing an alarm that said vehicle is too close to said object;

said processor subsystem determining, based upon data received from said radar detector, said at least one sensor and said memory subsystem, when to activate said vehicle proximity alarm circuit.

Control No. 90013252

24. (Original) Apparatus for optimizing operation of a vehicle according to claim 23 wherein said processor subsystem further comprises:

means for determining when road speed for said vehicle is increasing or decreasing;

means for determining when throttle position for said vehicle is increasing or decreasing; and

means for comparing manifold pressure to said manifold pressure set point;

means for determining when manifold pressure for said vehicle is increasing or decreasing; and

means for determining when engine speed for said vehicle is increasing or decreasing;

said processor subsystem activating said fuel overinjection notification circuit if both road speed and throttle position for said vehicle are increasing and manifold pressure for said vehicle is above said manifold pressure set point or if both throttle position and manifold pressure for said vehicle are increasing and road speed and engine speed for said vehicle are decreasing.

25. (Original) Apparatus for optimizing operation of a vehicle according to claim 23 wherein said processor subsystem further comprises:

means for determining when road speed for said vehicle is increasing;

means for determining when throttle position for said vehicle is increasing;

means for comparing manifold pressure to said manifold pressure set point;

and

means for comparing engine speed to said RPM set point;

said processor subsystem activating said upshift notification circuit if both road speed and throttle position for said vehicle are increasing, manifold pressure for said vehicle is at or below said manifold pressure set point and engine speed for said vehicle is at or above said RPM set point.

26. (Original) Apparatus for optimizing operation of a vehicle, comprising:

a radar detector, said radar detector determining a distance separating a vehicle having an engine and an object in front of said vehicle;

a plurality of sensors coupled to a vehicle having an engine, said plurality of sensors, which collectively monitor operation of said vehicle, including a road speed sensor, and engine speed sensor, a manifold pressure sensor and a throttle position sensor;

a processor subsystem, coupled to said radar detector and each one of said plurality of sensors, to receive data therefrom;

a memory subsystem, coupled to said processor subsystem, said memory subsystem storing therein a first vehicle speed/stopping distance table, a manifold pressure set point, RPM set point, and present and prior levels for each one of said plurality of sensors;

a fuel overinjection notification circuit coupled to said processor subsystem, said fuel overinjection notification circuit issuing a notification that excessive fuel is being supplied to said engine of said vehicle;

a downshift notification circuit coupled to said processor subsystem, said

Control No. 90013252

downshift notification circuit issuing a notification that said engine of said vehicle is being operated at an insufficient engine speed;

said processor subsystem determining, based upon data received from said plurality of sensors, when to activate said fuel overinjection circuit and when to activate said downshift notification circuit;

a vehicle proximity alarm circuit coupled to said processor subsystem, said vehicle proximity alarm circuit issuing an alarm that said vehicle is too close to said object;

said processor subsystem determining, based upon data received from said radar detector, said at least one sensor and said memory subsystem, when to activate said vehicle proximity alarm circuit.

27. (Original) Apparatus for optimizing operation of a vehicle according to claim 26 wherein said processor subsystem further comprises:

means for determining when road speed for said vehicle is decreasing;

means for determining when throttle position for said vehicle is increasing;

means for determining when manifold pressure for said vehicle is increasing;

and

means for determining when engine speed for said vehicle is decreasing;

said processor subsystem activating said downshift notification circuit if both road speed and engine speed are decreasing and both throttle position and manifold pressure for said vehicle are increasing.

28. (Original) Apparatus for optimizing operation of a vehicle, comprising:

a plurality of sensors coupled to a vehicle having an engine, said plurality of sensors, which collectively monitor operation of said vehicle, including a road speed sensor, a manifold pressure sensor and a throttle position sensor;

a processor subsystem, coupled to each one of said plurality of sensors, to receive data therefrom;

a fuel overinjection notification circuit coupled to said processor subsystem, said fuel overinjection notification circuit issuing a notification that excessive fuel is being supplied to said engine of said vehicle;

said processor subsystem determining whether to activate said fuel overinjection notification sensor based upon data received from said road speed sensor, said throttle position sensor and said manifold pressure sensor.

29. (Original) Apparatus according to claim 28 and further comprising:

a memory subsystem, coupled to said processor subsystem, said memory subsystem maintaining a manifold pressure set point;

said processor subsystem activating said fuel overinjection notification circuit upon determining that:

(1) based upon data received from said road speed sensor, road speed of said vehicle is increasing;

(2) based upon data received from said throttle position sensor, throttle position for said vehicle is increasing; and

(3) based upon data received from said manifold pressure sensor, manifold



Control No. 90013252

pressure for said vehicle exceeds said manifold pressure set point.

30. (Original) Apparatus according to claim 28, wherein:

said plurality of sensors coupled to said vehicle further include an engine speed sensor;

said processor subsystem activating said fuel overinjection notification circuit upon determining that:

(1) based upon data received from said road speed sensor, road speed of said vehicle is decreasing;

(2) based upon data received from said throttle position sensor, throttle position for said vehicle is increasing;

(3) based upon data received from said manifold pressure sensor, manifold pressure for said vehicle is increasing; and

(4) based upon data received from said engine speed sensor, engine speed for said vehicle is decreasing.

31. (Amended) Apparatus for optimizing operation of a vehicle, comprising:

a radar detector, said radar detector determining a distance separating a vehicle having an engine and an object in front of said vehicle;

~~at least one~~ a plurality of sensors coupled to said vehicle for monitoring operation thereof, said ~~at least one~~ plurality of sensors including a road speed sensor and an engine speed sensor;

a processor subsystem, coupled to said radar detector and said at least one sensor, to receive data therefrom;

Control No. 90013252

a memory subsystem, coupled to said processor subsystem, said memory subsystem storing a first vehicle speed/stopping distance table;

a vehicle proximity alarm circuit coupled to said processor subsystem, said vehicle proximity alarm circuit issuing an alarm that said vehicle is too close to said object;

said processor subsystem determining whether to activate said vehicle proximity alarm circuit based upon separation distance data received from said radar detector, vehicle speed data received from said road speed sensor and said first vehicle speed/stopping distance table stored in said memory subsystem; and

a throttle controller for controlling a throttle of said engine of said vehicle;

wherein said processor subsystem selectively reduces said throttle based upon the data received from said radar detector;

further wherein the processor subsystem includes (i) an active mode in which the processor subsystem activates the vehicle proximity alarm circuit to issue the vehicle proximity alarm and reduces the throttle based upon the data received from said radar detector, and (ii) an inactive mode in which the processor subsystem activates the vehicle proximity alarm circuit to issue the alarm and the throttle is not selectively reduced based upon the data received from said radar detector.

32. (Original) Apparatus for optimizing operation of a vehicle according to claim 31 wherein:

said at least one sensor further includes a windshield wiper sensor for indicating whether a windshield wiper of said vehicle is activated; and

Control No. 90013252

said memory subsystem further storing a second vehicle speed/stopping distance table;

if said windshield wiper sensor indicates that said windshield wiper is deactivated, said processor subsystem determining whether to activate said vehicle proximity alarm circuit based upon data received from said radar detector, said road speed sensor and said first vehicle speed/stopping distance table stored in said memory subsystem;

if said windshield wiper sensor indicates that said windshield wiper is activated, said processor subsystem determining whether to activate said vehicle proximity alarm circuit based upon data received from said radar detector, said road speed sensor and said second vehicle speed/stopping distance table stored in said memory subsystem.

33. (New) Apparatus for optimizing operation of a vehicle according to claim 1 further comprising:

means for determining a distance separating a vehicle and an object, wherein the vehicle includes an engine; and

a vehicle proximity alarm circuit coupled to said processor subsystem, wherein the vehicle proximity alarm circuit includes at least one of a visual notification and an audible notification;

wherein, upon the processor subsystem receiving the distance from said means for determining a distance and determining said distance is less than a predetermined distance, the processor subsystem activates the vehicle proximity alarm circuit.

34. (New) Apparatus for optimizing operation of a vehicle according to claim 33, further comprising:

a throttle controller for controlling a throttle of said engine of said vehicle;

wherein, upon the processor subsystem receiving the distance from said means for determining a distance and determining said distance received is less than a predetermined distance, the processor subsystem reduces said throttle.

35. (New) Apparatus for optimizing operation of a vehicle according to claim 33, further wherein the processor subsystem determines whether the brakes of the vehicle are activated.

36. (New) Apparatus for optimizing operation of a vehicle according to claim 33, wherein the vehicle proximity alarm circuit further comprises a display for displaying at least one of the speed of the object, and the distance to the object.

37. (New) Apparatus for optimizing operation of a vehicle according to claim 34, wherein the processor subsystem includes (i) an active mode wherein the processor subsystem activates an alarm and reduces the throttle based upon the distance received from said means for determining, and (ii) an inactive mode wherein the processor subsystem activates an alarm and the processor subsystem does not reduce the throttle based upon the distance received from said means for determining.

38. (New) Apparatus for optimizing operation of a vehicle according to claim 37, further comprising a means for mode selection between said active mode and said inactive mode.

Control No. 90013252

39. (New) Apparatus for optimizing operation of a vehicle according to claim 1, wherein said plurality of sensors is the engine speed sensor and the vehicle speed sensor.

40. (New) Apparatus for optimizing operation of a vehicle according to claim 1, wherein said notification that the engine is being operated an excessive speed comprises an automatic corrective action by the vehicle.

41. (New) Apparatus for optimizing operation of a vehicle according to claim 1, wherein said notification that the engine is being operated at an excessive speed notifies a driver that an upshift should be performed.

42. (New) Apparatus for optimizing operation of a vehicle according to claim 1, wherein said notification that excessive fuel is being supplied to said engine of said vehicle notifies a driver that the vehicle is not being operated fuel efficiently.

43. (New) Apparatus for optimizing operation of a vehicle according to claim 1, wherein said manifold pressure set point is a manifold pressure threshold value.

44. (New) Apparatus for optimizing operation of a vehicle according to claim 1, wherein said manifold pressure set point is a threshold value above which the manifold pressure should not exceed.

45. (New) Apparatus for optimizing operation of a vehicle according to claim 1, wherein said processor subsystem determines when to activate said fuel overinjection circuit and said upshift notification circuit based upon said manifold pressure set point and said RPM set point.

46. (New) Apparatus for optimizing operation of a vehicle according to claim 1, wherein said determination to activate said fuel overinjection circuit is based on data from the road speed sensor.

47. (New). Apparatus for optimizing operation of a vehicle according to claim 1, wherein said determination to activate said fuel overinjection circuit is based on data from the manifold pressure sensor.

48. (New) Apparatus for optimizing operation of a vehicle according to claim 1, wherein said determination to activate said fuel overinjection circuit is based on data from the throttle position sensor.

49. (New) Apparatus for optimizing operation of a vehicle according to claim 1, wherein said processor subsystem is configured to automatically power on when the vehicle is started.

50. (New) Apparatus for optimizing operation of a vehicle according to claim 1, wherein said determination when to activate said fuel overinjection circuit and said determination when to activate said upshift notification circuit is based upon said present and prior levels for said plurality of sensors stored in said memory subsystem.

51. (New) Apparatus for optimizing operation of a vehicle according to claim 1, wherein said processor subsystem is configured to periodically communicate with said plurality of sensors.

52. (New) Apparatus for optimizing operation of a vehicle according to claim 1, wherein said processor subsystem is configured to retrieve data from the plurality of sensors and store the data in said memory subsystem.

Control No. 90013252

53. (New) Apparatus for optimizing operation of a vehicle according to claim 17, wherein the processor subsystem includes (i) an active mode wherein the processor subsystem activates an alarm and reduces the throttle based upon a distance received from said radar detector, and (ii) an inactive mode wherein the processor subsystem activates an alarm and the processor subsystem does not reduce the throttle based upon a distance received from said radar detector.

54. (New) Apparatus for optimizing operation of a vehicle according to claim 53, further comprising a means for mode selection between said active mode and said inactive mode.

55. (New) Apparatus for optimizing operation of a vehicle according to claim 17, wherein said processor subsystem activates said upshift notification circuit based on the manifold pressure set point and RPM set point.

56. (New) Apparatus for optimizing operation of a vehicle according to claim 17, wherein said at least one sensor is the road speed sensor.

57. (New) Apparatus for optimizing operation of a vehicle according to claim 17, wherein the first speed/stopping distance table is based on National Safety Council guidelines.

58. (New) Apparatus for optimizing operation of a vehicle according to claim 17, further wherein said processor subsystem automatically applies the brakes based upon data received from said radar detector, said at least one sensor and said memory subsystem.

59. (New) Apparatus for optimizing operation of a vehicle according to claim 28 further comprising:

Control No. 90013252

a means for determining a distance separating a vehicle and an object, wherein the vehicle includes an engine; and

a vehicle proximity alarm circuit coupled to said processor subsystem;

wherein said processor subsystem activates said vehicle proximity alarm circuit based at least upon the data received from said road speed sensor, and the means for determining the distance separating the vehicle and the object.

60. (New) Apparatus for optimizing operation of a vehicle according to claim 31, further comprising:

a fuel overinjection notification circuit coupled to said processor subsystem, said fuel overinjection notification circuit issuing a notification that excessive fuel is being supplied to said engine of said vehicle;

wherein said processor subsystem determines whether to activate said fuel overinjection notification circuit based upon at least the data received from said road speed sensor.

61. (New) Apparatus for optimizing operation of a vehicle according to claim 31, further comprising:

a display;

wherein the vehicle proximity alarm includes at least one of an audible indication, and a visual indication; and

wherein the visual indication is displayed on the display.

62. (New) Apparatus for optimizing operation of a vehicle according to claim 31, further comprising means for mode selection between said active mode and said inactive mode.



Control No. 90013252

63. (New) Apparatus for optimizing operation of a vehicle according to claim 31, further comprising a selector for selecting a type of vehicle proximity alarm, wherein the type of vehicle proximity alarm is selected from the group consisting of an audible indication, a visual indication, and combinations thereof.

64. (New) Apparatus for optimizing operation of a vehicle according to claim 31, wherein said first speed/stopping distance table is a lookup table.

65. (New) Apparatus for optimizing operation of a vehicle according to claim 65, wherein said first speed/stopping distance table is based upon National Safety Council guidelines.

66. (New) Apparatus for optimizing operation of a vehicle according to claim 31, further comprising an upshift notification circuit coupled to said processor subsystem.

67. (New) Apparatus for optimizing operation of a vehicle according to claim 31, further wherein said processor subsystem determines whether the brakes of the vehicle are activated.

68. (New) Apparatus for optimizing operation of a vehicle according to claim 31, further comprising a bus for bidirectional exchanges of address, data and control signals between said processor subsystem and said memory subsystem.

69. (New) Apparatus for optimizing operation of a vehicle according to claim 31, wherein said memory subsystem includes at least one register for holding the level of said road speed sensor.

70. (New) Apparatus for optimizing operation of a vehicle according to claim 31, further comprising a tachometer.

Control No. 90013252

71. (New) Apparatus for optimizing operation of a vehicle according to claim 70, further comprising a speedometer.

72. (New) Apparatus of optimizing operation of a vehicle according to claim 31, wherein said vehicle comprises a truck.

73. (New) Apparatus for optimizing operation of a vehicle according to claim 31, further comprising a power source including voltage divider circuitry.

74. (New) Apparatus for optimizing operation of a vehicle according to claim 31, wherein said memory subsystem stores vehicle class information.

75. (New) Apparatus for optimizing operation of a vehicle according to claim 31, wherein said processor subsystem is configured to automatically power on when the vehicle is started.

76. (New) Apparatus for optimizing operation of a vehicle according to claim 31, wherein said processor subsystem is configured to periodically communicate with said road speed sensor.

77. (New) Apparatus for optimizing operation of a vehicle according to claim 31, wherein said processor subsystem is configured to retrieve data from said road speed sensor and store the data in said memory subsystem.

78. (New) Apparatus for optimizing operation of a vehicle according to claim 31, wherein said processor subsystem is configured to wait a preselected time period after issuing the vehicle proximity alarm.

79. (New) Apparatus for optimizing operation of a vehicle according to claim 31, wherein said processor subsystem is configured to select a type of vehicle proximity alarm based on the determined distance, wherein the type of vehicle proximity

Control No. 90013252

alarm is selected from the group consisting of an audible indication, a visual indication, and combinations thereof.

80. (New) Apparatus for optimizing operation of a vehicle according to claim 31, wherein said first speed/stopping distance table is the relationship between vehicle speed and stopping distance.

81. (New) Apparatus for optimizing operation of a vehicle according to claim 71, further comprising a fuel overinjection notification circuit coupled to said processor subsystem, said fuel overinjection notification circuit issuing a notification that excessive fuel is being supplied to said engine of said vehicle.

82. (New) Apparatus for optimizing operation of a vehicle according to claim 71, further comprising an upshift notification circuit coupled to said processor subsystem.

83. (New) Apparatus for optimizing operation of a vehicle according to claim 71, wherein said vehicle proximity alarm includes an audible indication and a visual indication.

84. (New) Apparatus for optimizing operation of a vehicle according to claim 71, further comprising means for mode selection between said active mode and said inactive mode.

**Remarks**

New claims 33-84 have been added. No new matter has been added by the amendments and new claims presented herein. Reconsideration and reexamination of the claims in light of the following remarks is requested.

**Patentable Claims**

Patent Owner thanks the Examiner for identifying and confirming claims 1, 2, 4, 5, 7, 8, 10, 12, 13, 15, and 17-30 as patentable in the present reexamination proceeding.

Patent Owner agrees that none of the prior art submitted by the Requester anticipates or renders obvious the patent claims. The Patent Owner comments here on certain ambiguities in the Examiner's Statement of Reasons for Patentability and/or Confirmation.

The Examiner notes that none of the prior art of record discloses "a fuel overinjection notification circuit coupled to said processor subsystem, said fuel overinjection notification circuit issuing a notification that excessive fuel is being supplied to said engine of said vehicle." The Patent Owner agrees.

When discussing "Jurgen," the Examiner states: "The '781 Patent's thresholds allow the engine to reach a state of overinjection." The Examiner's statement is true. But the statement is ambiguous such that it could be misconstrued to imply that "overinjection" is a consequence of the claimed invention. Any such implication is manifestly inconsistent with the invention and wrong. Rather, every vehicle with an engine can operate in a "state of overinjection" as a result of inefficient driver operation.

Control No. 90013252

In the claimed invention, certain sensor data is used by a processor subsystem to trigger driver notifications regarding driver fuel inefficient operation and/or driver unsafe operation, not affect how fuel is injected into the vehicle's engine.

The Patent describes an inventive system that “notifies a driver of recommended corrections in vehicle operation and, under certain conditions, automatically initiates corrective action.” (*See* ‘781 Patent, at col. 1:7-9.) For example, in the Background of the Invention, the Patent describes how “fuel efficiency of a vehicle may vary dramatically based upon how the vehicle is operated. More specifically, operating a vehicle at excessive speed, excessive RPM and/or excessive manifold pressure will result in both reduced fuel economy and increased operating costs.” (*See id.* at col. 1:11-16.) The Patent continues: “To correct these type of *improper vehicle operations* are often surprisingly simple ... However, even when the solution is quite simple, oftentimes, the driver will be unaware of the need to take corrective action.” (*See id.* at col. 1:19-26 (emphasis added).) Accordingly, the system of the Patent aims to issue notifications that suggest a driver change how he or she is operating a vehicle in order to improve fuel economy/efficiency and safety.

One embodiment of a notification in the Patent is an “overinjection notification.” In the preferred embodiment, the system analyzes inputs from one or more sensors to make determinations regarding the vehicle’s “fuel consumption.” (*See id.* at col. 11:41 & col. 12:28-29.) Based on these determinations, when appropriate, the system provides “overinjection notifications” and/or “upshift/downshift notifications” that advise a driver

if his or her driving is fuel inefficient.<sup>1</sup> The system in the preferred embodiment therefore recommends actions (*e.g.*, easing off the throttle or slowing down when speeding) that, if taken by the driver, will result in “greater fuel efficiency.” (*See id.* at col. 13:44.)<sup>2</sup>

Stated another way, the invention of the Patent is not directed at a particular internal combustion engine programmed to inject fuel according to one scheme versus another internal combustion engine programmed to inject fuel according to another scheme. The claims in the Patent discussed by the Examiner are broadly directed at all fuel-consuming engines in vehicles.<sup>3</sup> Accordingly, the Patent describes that all engines in vehicles will inject as much fuel as driver demands by his or her operation of the vehicle. If the driver operates the vehicle in a fuel inefficient manner (*e.g.*, excessively speeding, abruptly accelerating, etc.), the engine will overinject more fuel than the engine would if the vehicle were being operated efficiently. In that circumstance, the inventive system of the Patent will provide the driver with a “overinjection notification” as an alert that his or her driving is fuel inefficient.

Moreover, again in the interest of a clear record, the Patent Owner addresses certain prior art identified by the Requester and discussed by the Examiner. The Patent Owner agrees that none of the prior art anticipates or renders obvious the examined patent claims.

---

<sup>1</sup> The upshift and downshift notifications are also related to fuel efficiency and protecting the engine from overrevving (excessive engine speed) or lugging (insufficient engine speed).

<sup>2</sup> The preferred embodiment also provides additional notifications regarding safe operation of the vehicle. It also describes situations where the system automatically alters operation of the vehicle in certain situations (*e.g.*, controlling the throttle).

<sup>3</sup> To be clear, Claim 31 is not limited to fuel-consuming engines.

First, the Examiner properly notes that what the Requester calls “Jurgen” does not render the claims invalid. At the threshold, however, the Requester has improperly presented “Jurgen” as a single prior art reference. Jurgen is actually a collection of chapters or articles written by different authors describing different vehicles (or, more accurately, particular implementations of components in different vehicles) entitled by “Automotive Electronics Handbook,” and edited by Mr. Jurgen. The sections of the chapter discussed by the Examiner are actually written by Gary Hirschlieb, Gottfried Schiller & Shari Stottler. The chapters Requester calls “Jurgen” therefore are at best a number of discrete prior art references properly analyzed under section 103. *See Kyocera Wireless Corp. v. International Trade Comm’n*, 545 F.3d 1340, 1351-52 (Fed. Cir. 2008) (holding that specifications collected in the GSM standard which had different authors were a section 103 prior art combination, not a single section 102 prior art reference).

Moreover, “unless a reference discloses within the four corners of the document not only all of the limitations claimed but also all of the limitations **arranged or combined in the same way as recited in the claim**, it cannot be said to prove prior invention of the thing claimed and thus cannot anticipate[.]”) *NetMoneyIN, Inc. v. Verisign, Inc.*, 545 F.3d 1359, 1371 (Fed. Cir. 2008) (emphasis added); *see also Therasense, Inc. v. Becton, Dickinson & Co.*, 593 F.3d 1325, 1332 (Fed. Cir. 2010) (“The way in which elements are arranged or combined in the claim must itself be disclosed ... in an anticipatory reference.”) Because anticipation requires that prior art elements must themselves be “arranged as in the claim,” the claims must not be “treated ... as mere catalogs of separate parts, in disregard of the part-to-part relationships set forth in the claims and that give the claims their meaning.” *Lindemann Maschinen-fabrik*

*GMBH v. Am. Hoist & Derrick Co.*, 730 F.2d 1452, 1459 (Fed. Cir. 1984). Beyond mislabeling “Jurgen” as a single prior art reference, Requester made the legal error of treating the patent claims as a mere catalogue of parts from which it may pick and choose from various chapters to construct **some** of the elements of the claims. *See In re Arkley*, 455 F.2d 586, 587 (CCPA 1971) (holding that “picking, choosing and combining various disclosures not directed related to each other” is legal error). Of course, Requester does not even allege that what it calls “Jurgen” anticipates any claims. Therefore, Requester made the next step of combining the various unrelated, cobbled-together parts of what it called “Jurgen” with other prior art references. Such hindsight cherry picking (particularly without anything other than conclusory lip service to motivation to combine) is the classic example of what is strictly forbidden for an obviousness inquiry. The Examiner correctly rejected Requester’s position. Nevertheless, in the interest of a clear prosecution record, Patent Owner has explained why there is no “Jurgen” reference.

In all events, the sections of the chapter in “Jurgen” referenced by the Examiner do not disclose any notification to a driver. Rather, the sections discuss a fuel shutoff scheme that is invisible to the driver. Under certain circumstances, depending on throttle position, engine speed and vehicle speed, the fuel shutoff scheme will result in turning off fuel injection during braking or coasting. That is, if appropriate, the engine will automatically execute a fuel saving strategy when the vehicle is slowing down to a stop. The sections of the chapter in “Jurgen” referenced by the Examiner, however, say nothing at all about driver contributions to fuel inefficiency that can be corrected. Accordingly, not only does the chapter sections relied upon by the Examiner fail to disclose the notification(s) required by the claim(s), it also does not discuss fuel



inefficient operation by a driver. The Patent Owner respectfully submits that the sections of the chapter of “Jurgen” discussed by the Examiner are marginally relevant at best.

Second, the Patent Owner agrees with the Examiner that “the Volkswagen ‘070’s teachings are directed towards shifting the gears of an engine.” The Examiner states that the Volkswagen ‘070 notes, according to the English translation, “a display of the route-specific fuel consumption provide in a vehicle.” But, as the Examiner correctly concludes, the Volkswagen ‘070 fails to disclose issuance of notifications (*e.g.*, a light that goes on or off when appropriate, a horn or chime that sounds when appropriate, a visual indication showing a deviation below a mean value when appropriate, etc.) when a driver is operating a vehicle in a fuel inefficient manner.<sup>4</sup>

#### **Litigation Activity**

According to 37 C.F.R. 1.565(a), Applicants notify the Office that the following cases have been stayed until resolution of the present reexamination proceeding: *Velocity Patent LLC v. Mercedes-Benz USA, LLC*, Civil Action No. 1:13-cv-08413 (N.D. Ill.); *Velocity Patent LLC v. Audi of America, Inc.*, Civil Action No. 1:13-cv-08418 (N.D. Ill.); *Velocity Patent LLC v. Chrysler Group, LLC*, Civil Action No. 1:13-cv-08419 (N.D. Ill). Under the circumstances, Patent Owner has responded to the Office Action in less than a month so that present reexamination might continue to proceed with special dispatch. Patent Owner thanks the Examiner in advance for the Examiner’s diligent attention to this matter so that the litigation stays identified above may be lifted shortly.

---

<sup>4</sup> Patent Owner believes that many additional claim elements are not disclosed by the Volkswagen ‘070, and has identified them in the related litigation(s). Requester of course concedes that the Volkswagen ‘070 does not anticipate any patent claims.

Control No. 90013252

Patent Owner also notes for the Examiner's attention the pending petition for inter partes review filed by Mercedes-Benz USA, LLC and Mercedes-Benz U.S. International, Inc. concerning claims 31 and 32. The petition can be located at *Mercedes-Benz USA, LLC et. al. v. Velocity Patent, LLC*, Case IPR 2014-0127. Patent Owner believes that, in light of Patent Owner's amendment to Claim 31 here, the petition must be denied as a matter of law.

### **Claim Rejections**

Claim 31 is rejected under 35 U.S.C. 102(b) as being unpatentable over Davidian (U.S. Patent No. 5,357,438).

Without conceding that the Examiner's stated reasons in support of the rejection are correct, the Patent Owner has amended Claim 31, thereby mooting the Examiner's rejection. The Patent Owner respectfully submits that the elements added to Claim 31 are not disclosed in either Davidian or Tonkin. Specifically, both Davidian and Tonkin fail to disclose (1) an engine speed sensor, (2) a throttle controller for controlling a throttle of said engine of said vehicle, (3) wherein said processor subsystem selectively reduces said throttle based upon the data received from said radar detector and (4) further wherein the processor subsystem includes (i) an active mode in which the processor subsystem activates the vehicle proximity alarm circuit to issue the vehicle proximity alarm and reduces the throttle based upon the data received from said radar detector, and (ii) an inactive mode in which the processor subsystem activates the vehicle proximity alarm circuit to issue the alarm and the throttle is not selectively reduced based upon the data received from said radar detector. Patent Owner respectfully submits that Claim 31 is now

Control No. 90013252

significantly and patentably distinct from Davidian, Tonkin or any combination of the two (which Patent Owner does not concede there would be any motivation to do).

Claim 32 is rejected under 35 U.S.C. 103(a) as being unpatentable over Davidian in view of Tonkin (PCT Pub. No. WO/02853). Claim 32 depends from Claim 31, which is patentable for reasons discussed above. Accordingly, the Examiner's rejection is moot.

#### **New Claims**

Because new claims 33-59 depend from confirmed patentable claims 2, 4, 5, 7, 8, 10, 12, 13, 15, and 17-30, the new claims are also patentable. New claims 60-84 depend from amended claim 31, which is patentable for reasons discussed above. While Patent Owner believes that all of the examined claims are patentable over the prior art of record, out of an abundance of caution, Patent Owner has submitted the new dependent claims to further distinguish all of the prior art cited by Requester under the provisions of 35 U.S.C. § 301.

**Conclusion**

In view of the foregoing remarks, Patent Owner submits that all of the currently pending claims are in allowable form and that the application is in condition for allowance. Therefore, Patent Owner respectfully requests that a timely Notice of Allowance be issued in this case. If for any reason the Examiner is unable to allow the application and feels that an interview would be helpful to resolve any remaining issues, the Examiner is requested to contact the undersigned attorney at (312) 283-8555.

Respectfully submitted,

RICHARDS PATENT LAW PC



Patrick D. Richards  
Registration. No. 48,905

**Please recognize Customer No. 88360  
as the correspondence address.**

Richards Patent Law P.C.  
233 S. Wacker Dr., 84<sup>th</sup> Floor  
Chicago, IL 60606  
Phone: (312) 283-8555  
**Date: November 3, 2014**

Doc code: IDS

Doc description: Information Disclosure Statement (IDS) Filed

PTO/SB/08a (3-1-10)

Approved for use through 07/31/2012. OMB 0651-0031  
U.S. Patent and Trademark Office, U.S. DEPARTMENT OF COMMERCE

Under the Paperwork Reduction Act of 1995, no persons are required to respond to a collection of information unless it contains a valid GMB control number.

<b>INFORMATION DISCLOSURE STATEMENT BY APPLICANT</b> ( Not for submission under 37 CFR 1.99)	Application Number	90013252
	Filing Date	2014-05-22
	First Named Inventor	HARVEY SLEPIAN
	Art Unit	3992
	Examiner Name	England, David E.
	Attorney Docket Number	1089-001

U.S.PATENTS								
Examiner Initial*	Cite No	Patent Number	Kind Code <sup>1</sup>	Issue Date	Name of Patentee or Applicant of cited Document	Pages, Columns, Lines where Relevant Passages or Relevant Figures Appear		
	130	5072703		1991-12-17	Loran W. Sutton			
	131	5222469		1993-06-29	Loran W. Sutton			
	132	5317998		1994-06-07	Jay L. Hanson			
	133	5432497		1995-07-11	Tony Briski			
If you wish to add additional U.S. Patent citation information please click the Add button.								
U.S.PATENT APPLICATION PUBLICATIONS								
Examiner Initial*	Cite No	Publication Number	Kind Code <sup>1</sup>	Publication Date	Name of Patentee or Applicant of cited Document	Pages, Columns, Lines where Relevant Passages or Relevant Figures Appear		
	1							
If you wish to add additional U.S. Published Application citation information please click the Add button.								
FOREIGN PATENT DOCUMENTS								
Examiner Initial*	Cite No	Foreign Document Number <sup>3</sup>	Country Code <sup>21</sup>	Kind Code <sup>4</sup>	Publication Date	Name of Patentee or Applicant of cited Document	Pages, Columns, Lines where Relevant Passages or Relevant Figures Appear	T <sup>5</sup>



<b>INFORMATION DISCLOSURE STATEMENT BY APPLICANT</b> ( Not for submission under 37 CFR 1.99)	Application Number	90013252
	Filing Date	2014-05-22
	First Named Inventor	HARVEY SLEPIAN
	Art Unit	3992
	Examiner Name	England, David E.
	Attorney Docket Number	1089-001

<u>100</u>	HONORABLE JUDGE MICHAEL T. MASON, Case No. 13-CV-08418 Docket # 91 Order by Honorable Judge Mason Granting in Part and Denying in Part Velocity Patent LLC's Motion to Compel 2.1(b)(1) Discovery, District Court for the Northern District of Illinois Eastern Division, Judge's Order, 2014-07-11, Chicago, Illinois.	<input type="checkbox"/>
<u>101</u>	VELOCITY PATENT LLC, Case No. 13-CV-08418 Docket # 99 Velocity Patent LLC's Objection to Order Regarding Plaintiff's Motion to Compel LPR 2.1(b)(1) Disclosures and Responses to Discovery and Plaintiff's Motion to Compel LPR 2.4(a) Disclosures, District Court for the Northern District of Illinois Eastern Division, Case Pleading, 2014-07-25, Chicago, Illinois.	<input type="checkbox"/>
<u>102</u>	AUDI OF AMERICA, INC, Case No. 13-CV-08418 Docket # 101 Audi Of America, Inc.'s Objections to Magistrate Judge Mason's Order Granting-In-Part Plaintiff's Motion to Compel, District Court for the Northern District of Illinois Eastern Division, Case Pleading, 2014-07-28, Chicago, Illinois.	<input type="checkbox"/>
<u>103</u>	HONORABLE JUDGE John W. Darrah, Case No. 13-CV-08418 Docket # 106 Order - Audi's Motion to Dismiss for Failure to State a Claim [36] is Denied, District Court for the Northern District of Illinois Eastern Division, Judge's Order, 2014-08-20, Chicago, Illinois.	<input type="checkbox"/>
<u>104</u>	HONORABLE JUDGE John W. Darrah, Case No. 13-CV-08418 Docket # 107 Memorandum Opinion and Order - Audi's Motion to Dismiss for Failure to State a Claim [36] is Denied, District Court for the Northern District of Illinois Eastern Division, Judge's Order, 2014-08-20, Chicago, Illinois.	<input type="checkbox"/>
<u>105</u>	VELOCITY PATENT LLC, Case No. 13-CV-08418 Docket # 109 Velocity Patent LLC's Motion to Compel Discovery Relating to Past Damages, District Court of the Northern District of Illinois Eastern Division, Case Pleading, 2014-09-03, Chicago, Illinois.	<input type="checkbox"/>
<u>106</u>	AUDI OF AMERICA, INC, Case No. 13-CV-08418 Docket # 110 Audi's Response to Velocity Patent LLC's Objection to Magistrate Judge Mason's July 11, 2014 Order Granting-In-Part Plaintiff's Motion to Compel, District Court for the Northern District of Illinois Eastern Division, Case Pleading, 2014-09-03, Chicago, Illinois.	<input type="checkbox"/>
<u>107</u>	VELOCITY PATENT LLC, Case No. 13-CV-08418 Docket # 112 Velocity Patent LLC's Motion for Leave to File a Reply Brief, District Court for the Northern District of Illinois Eastern Division, Case Pleading, 2014-09-15, Chicago, Illinois.	<input type="checkbox"/>
<u>108</u>	HONORABLE JUDGE John W. Darrah, Case No. 13-CV-08418 Docket # 114 Minute Entry - Plaintiff's Motion for Leave to File Reply to Audi's Opposition to Motion to Compel Discovery Relating to Past Damages [112] is granted, District Court for the Northern District of Illinois Eastern Division, Judge Minute Entry, 2014-09-16, Chicago, Illinois.	<input type="checkbox"/>
<u>109</u>	VELOCITY PATENT LLC, Case No. 13-CV-08418 Docket # 115 Velocity Patent LLC's Reply to Audi of America, Inc.'s Opposition to Motion to Compel Discovery Relating to Past Damages, District Court for the Northern District of Illinois Eastern Division, Case Pleading, 2014-09-16, Chicago, Illinois.	<input type="checkbox"/>
<u>110</u>	AUDI OF AMERICA, INC, Case No. 13-CV-08418 Docket # 118 Audi of America, Inc.'s Sur-Reply to Velocity Patent LLC's Objection to Magistrate Mason's July 11, 2014 Order Granting-In-Part Plaintiff's Motion to Compel, District Court for the Northern District of Illinois Eastern Division, Case Pleading, 2014-10-15, Chicago, Illinois.	<input type="checkbox"/>

<b>INFORMATION DISCLOSURE STATEMENT BY APPLICANT</b> ( Not for submission under 37 CFR 1.99)	Application Number	90013252
	Filing Date	2014-05-22
	First Named Inventor	HARVEY SLEPIAN
	Art Unit	3992
	Examiner Name	England, David E.
	Attorney Docket Number	1089-001

111	VELOCITY PATENT LLC, Case No. 13-CV-08418 Docket # 120 Velocity Patent LLC's Response to Audi of America, Inc.'s Sur-Reply Regarding Velocity Patent LLC's Objection to Judge Mason's July 11, 2014 Order Regarding Plaintiff's Motion to Compel, District Court for the Northern District of Illinois Eastern Division, Case Pleading, 2014-10-21, Chicago, Illinois.	<input type="checkbox"/>
112	MERCEDES-BENZ USA, LLC ET. AL. v. VELOCITY PATENT LLC, Case IPR2014-01247, Patent No. 5954781, Application No. 08813270, USPTO, Filing Date 2014-08-04.	<input type="checkbox"/>

If you wish to add additional non-patent literature document citation information please click the Add button

**EXAMINER SIGNATURE**

Examiner Signature		Date Considered	
--------------------	--	-----------------	--

<sup>1</sup>EXAMINER: Initial if reference considered, whether or not citation is in conformance with MPEP 609. Draw line through a citation if not in conformance and not considered. Include copy of this form with next communication to applicant.

<sup>1</sup> See Kind Codes of USPTO Patent Documents at [www.USPTO.GOV](http://www.USPTO.GOV) or MPEP 901.04. <sup>2</sup> Enter office that issued the document, by the two-letter code (WIPO Standard ST.3). <sup>3</sup> For Japanese patent documents, the indication of the year of the reign of the Emperor must precede the serial number of the patent document. <sup>4</sup> Kind of document by the appropriate symbols as indicated on the document under WIPO Standard ST.16 if possible. <sup>5</sup> Applicant is to place a check mark here if English language translation is attached.



<b>INFORMATION DISCLOSURE STATEMENT BY APPLICANT</b> ( Not for submission under 37 CFR 1.99)	Application Number	90013252
	Filing Date	2014-05-22
	First Named Inventor	HARVEY SLEPIAN
	Art Unit	3992
	Examiner Name	England, David E.
	Attorney Docket Number	1089-001

**CERTIFICATION STATEMENT**

Please see 37 CFR 1.97 and 1.98 to make the appropriate selection(s):

That each item of information contained in the information disclosure statement was first cited in any communication from a foreign patent office in a counterpart foreign application not more than three months prior to the filing of the information disclosure statement. See 37 CFR 1.97(e)(1).

OR

That no item of information contained in the information disclosure statement was cited in a communication from a foreign patent office in a counterpart foreign application, and, to the knowledge of the person signing the certification after making reasonable inquiry, no item of information contained in the information disclosure statement was known to any individual designated in 37 CFR 1.56(c) more than three months prior to the filing of the information disclosure statement. See 37 CFR 1.97(e)(2).

See attached certification statement.

The fee set forth in 37 CFR 1.17 (p) has been submitted herewith.

A certification statement is not submitted herewith.

**SIGNATURE**

A signature of the applicant or representative is required in accordance with CFR 1.33, 10.18. Please see CFR 1.4(d) for the form of the signature.

Signature	/Patrick D. Richards/	Date (YYYY-MM-DD)	2014-11-03
Name/Print	Patrick Richards	Registration Number	48905

This collection of information is required by 37 CFR 1.97 and 1.98. The information is required to obtain or retain a benefit by the public which is to file (and by the USPTO to process) an application. Confidentiality is governed by 35 U.S.C. 122 and 37 CFR 1.14. This collection is estimated to take 1 hour to complete, including gathering, preparing and submitting the completed application form to the USPTO. Time will vary depending upon the individual case. Any comments on the amount of time you require to complete this form and/or suggestions for reducing this burden, should be sent to the Chief Information Officer, U.S. Patent and Trademark Office, U.S. Department of Commerce, P.O. Box 1450, Alexandria, VA 22313-1450. **DO NOT SEND FEES OR COMPLETED FORMS TO THIS ADDRESS. SEND TO: Commissioner for Patents, P.O. Box 1450, Alexandria, VA 22313-1450.**

## Privacy Act Statement

The Privacy Act of 1974 (P.L. 93-579) requires that you be given certain information in connection with your submission of the attached form related to a patent application or patent. Accordingly, pursuant to the requirements of the Act, please be advised that: (1) the general authority for the collection of this information is 35 U.S.C. 2(b)(2); (2) furnishing of the information solicited is voluntary; and (3) the principal purpose for which the information is used by the U.S. Patent and Trademark Office is to process and/or examine your submission related to a patent application or patent. If you do not furnish the requested information, the U.S. Patent and Trademark Office may not be able to process and/or examine your submission, which may result in termination of proceedings or abandonment of the application or expiration of the patent.

The information provided by you in this form will be subject to the following routine uses:

1. The information on this form will be treated confidentially to the extent allowed under the Freedom of Information Act (5 U.S.C. 552) and the Privacy Act (5 U.S.C. 552a). Records from this system of records may be disclosed to the Department of Justice to determine whether the Freedom of Information Act requires disclosure of these records.
2. A record from this system of records may be disclosed, as a routine use, in the course of presenting evidence to a court, magistrate, or administrative tribunal, including disclosures to opposing counsel in the course of settlement negotiations.
3. A record in this system of records may be disclosed, as a routine use, to a Member of Congress submitting a request involving an individual, to whom the record pertains, when the individual has requested assistance from the Member with respect to the subject matter of the record.
4. A record in this system of records may be disclosed, as a routine use, to a contractor of the Agency having need for the information in order to perform a contract. Recipients of information shall be required to comply with the requirements of the Privacy Act of 1974, as amended, pursuant to 5 U.S.C. 552a(m).
5. A record related to an International Application filed under the Patent Cooperation Treaty in this system of records may be disclosed, as a routine use, to the International Bureau of the World Intellectual Property Organization, pursuant to the Patent Cooperation Treaty.
6. A record in this system of records may be disclosed, as a routine use, to another federal agency for purposes of National Security review (35 U.S.C. 181) and for review pursuant to the Atomic Energy Act (42 U.S.C. 218(c)).
7. A record from this system of records may be disclosed, as a routine use, to the Administrator, General Services, or his/her designee, during an inspection of records conducted by GSA as part of that agency's responsibility to recommend improvements in records management practices and programs, under authority of 44 U.S.C. 2904 and 2906. Such disclosure shall be made in accordance with the GSA regulations governing inspection of records for this purpose, and any other relevant (i.e., GSA or Commerce) directive. Such disclosure shall not be used to make determinations about individuals.
8. A record from this system of records may be disclosed, as a routine use, to the public after either publication of the application pursuant to 35 U.S.C. 122(b) or issuance of a patent pursuant to 35 U.S.C. 151. Further, a record may be disclosed, subject to the limitations of 37 CFR 1.14, as a routine use, to the public if the record was filed in an application which became abandoned or in which the proceedings were terminated and which application is referenced by either a published application, an application open to public inspections or an issued patent.
9. A record from this system of records may be disclosed, as a routine use, to a Federal, State, or local law enforcement agency, if the USPTO becomes aware of a violation or potential violation of law or regulation.

## Electronic Acknowledgement Receipt

<b>EFS ID:</b>	20594828
<b>Application Number:</b>	90013252
<b>International Application Number:</b>	
<b>Confirmation Number:</b>	9999
<b>Title of Invention:</b>	Method and Apparatus for Optimizing Vehicle Operation
<b>First Named Inventor/Applicant Name:</b>	5,954,781
<b>Customer Number:</b>	88360
<b>Filer:</b>	Patrick Duffy Richards
<b>Filer Authorized By:</b>	
<b>Attorney Docket Number:</b>	
<b>Receipt Date:</b>	03-NOV-2014
<b>Filing Date:</b>	22-MAY-2014
<b>Time Stamp:</b>	18:43:22
<b>Application Type:</b>	Reexam (Third Party)

### Payment information:

Submitted with Payment	no
------------------------	----

### File Listing:

Document Number	Document Description	File Name	File Size(Bytes)/ Message Digest	Multi Part /.zip	Pages (if appl.)
1	Amendment/Req. Reconsideration-After Non-Final Reject	Response.pdf	279416 <small>71f3e3405bd051e86fd63bf6cf1dc86a691f5852</small>	no	37

### Warnings:

### Information:

2	Information Disclosure Statement (IDS) Form (SB08)	SupplDSForm.pdf	1908073	no	6
			72309a362e254c873b0db1d87d4139cc883479e		
<b>Warnings:</b>					
<b>Information:</b>					
This is not an USPTO supplied IDS fillable form					
3	Other Reference-Patent/App/Search documents	Ref1-12.pdf	24247073	no	284
			b396331dce91b8dbab72b06873ed61bfc982b2e		
<b>Warnings:</b>					
<b>Information:</b>					
4	Other Reference-Patent/App/Search documents	Ref25-36-1.pdf	12556895	no	500
			3fd2b3147f3146d43e2685884eac501f09569690		
<b>Warnings:</b>					
<b>Information:</b>					
5	Other Reference-Patent/App/Search documents	Ref25-36-2.pdf	5128118	no	500
			4d143262c5889027016d7f2e5e624738af246fef		
<b>Warnings:</b>					
<b>Information:</b>					
6	Other Reference-Patent/App/Search documents	Ref25-36-3.pdf	5463643	no	501
			3b289bc864dff6d49025a344804f942d03c2b577		
<b>Warnings:</b>					
<b>Information:</b>					
7	Other Reference-Patent/App/Search documents	Ref25-36-4.pdf	11822684	no	264
			6f12ea56863592d65a45af4c392a23a89074a1f3		
<b>Warnings:</b>					
<b>Information:</b>					
8	Other Reference-Patent/App/Search documents	Ref37-39.pdf	5419113	no	64
			455086aaace536c72d987a91226c0042411544121		
<b>Warnings:</b>					
<b>Information:</b>					
9	Other Reference-Patent/App/Search documents	14US5357438Davidian.pdf	1944631	no	41
			93f6d9e27156166861263fc217f93044dce53d25		
<b>Warnings:</b>					
<b>Information:</b>					
10	Other Reference-Patent/App/Search documents	16EP0549909SecondaryReference.pdf	718992	no	15
			d1faa094e76459d08c7bf4b9d16d0214753a07e7		

<b>Warnings:</b>					
<b>Information:</b>					
11	Other Reference-Patent/App/Search documents	13EP0392953Tresse.pdf	2499496 21bc311686b356e8261ea3fa06f445d3bc84db5	no	33
<b>Warnings:</b>					
<b>Information:</b>					
12	Other Reference-Patent/App/Search documents	15WO9107672Montague.pdf	3040852 8c1af056aafa3255427222d118f746868a0098a1	no	29
<b>Warnings:</b>					
<b>Information:</b>					
13	Other Reference-Patent/App/Search documents	17WO9602853SecondaryReference.pdf	4941845 2ceb08049b3e45bf056f92e26cf5edd1a50ebddd	no	43
<b>Warnings:</b>					
<b>Information:</b>					
14	Other Reference-Patent/App/Search documents	18DeclofDrChrisGBartoneinSupportofMercedesPetition.pdf	839924 3c3c2a5b23b79e736fae938400a4b44c6ff70c24	no	52
<b>Warnings:</b>					
<b>Information:</b>					
15	Other Reference-Patent/App/Search documents	19CVofDrChrisBartone.pdf	313573 028d630a7c32081eb867dd201e711a2a20d8fc50	no	23
<b>Warnings:</b>					
<b>Information:</b>					
16	Other Reference-Patent/App/Search documents	2014-04-08Dkt49MOTIONTOCOMPELLOCALPATENTRULE21b1DISCLOSURESANDRESPONSESTODISCOVERY.pdf	1091830 18baab4ba47e821fa1d680c06755e9aef742f51b	no	90
<b>Warnings:</b>					
<b>Information:</b>					
17	Other Reference-Patent/App/Search documents	2014-05-09Dkt70AudiBriefInOppositiontoVelocityMotionToCompel.pdf	12567390 bb40958e299a062df382e646edf8f83d21e72a48	no	64
<b>Warnings:</b>					
<b>Information:</b>					
18	Other Reference-Patent/App/Search documents	2014-06-05Dkt77AudiMottoStrikeNewArgumentsorFileaSurReplyinVelocityReplyMTC.pdf	182519 f05b775a614a40e4ff2d9f26ed3a160d80d504c8	no	9
<b>Warnings:</b>					
<b>Information:</b>					
19	Other Reference-Patent/App/Search documents	2014-06-05Dkt79MasonEntryAudiSur-ReplyWillbeConsidered610NoticeofMotionStricken.pdf	63737 57e0767496347998fbc25d043894cd781eba96	no	1

<b>Warnings:</b>	
<b>Information:</b>	
<b>Total Files Size (in bytes):</b>	95029804
<p><b>This Acknowledgement Receipt evidences receipt on the noted date by the USPTO of the indicated documents, characterized by the applicant, and including page counts, where applicable. It serves as evidence of receipt similar to a Post Card, as described in MPEP 503.</b></p> <p><b><u>New Applications Under 35 U.S.C. 111</u></b>  <b>If a new application is being filed and the application includes the necessary components for a filing date (see 37 CFR 1.53(b)-(d) and MPEP 506), a Filing Receipt (37 CFR 1.54) will be issued in due course and the date shown on this Acknowledgement Receipt will establish the filing date of the application.</b></p> <p><b><u>National Stage of an International Application under 35 U.S.C. 371</u></b>  <b>If a timely submission to enter the national stage of an international application is compliant with the conditions of 35 U.S.C. 371 and other applicable requirements a Form PCT/DO/EO/903 indicating acceptance of the application as a national stage submission under 35 U.S.C. 371 will be issued in addition to the Filing Receipt, in due course.</b></p> <p><b><u>New International Application Filed with the USPTO as a Receiving Office</u></b>  <b>If a new international application is being filed and the international application includes the necessary components for an international filing date (see PCT Article 11 and MPEP 1810), a Notification of the International Application Number and of the International Filing Date (Form PCT/RO/105) will be issued in due course, subject to prescriptions concerning national security, and the date shown on this Acknowledgement Receipt will establish the international filing date of the application.</b></p>	



UNITED STATES PATENT AND TRADEMARK OFFICE

UNITED STATES DEPARTMENT OF COMMERCE
United States Patent and Trademark Office
Address: COMMISSIONER FOR PATENTS
P.O. Box 1450
Alexandria, Virginia 22313-1450
www.uspto.gov

Table with 5 columns: APPLICATION NO., FILING DATE, FIRST NAMED INVENTOR, ATTORNEY DOCKET NO., CONFIRMATION NO.

90/013,252 05/22/2014 5,954,781 9999

88360 7590 10/21/2014
Richards Patent Law P.C.
233 S. Wacker Dr., 84th Floor
Chicago, IL 60606

EXAMINER

ENGLAND, DAVID E

ART UNIT PAPER NUMBER

3992

MAIL DATE DELIVERY MODE

10/21/2014 PAPER

Please find below and/or attached an Office communication concerning this application or proceeding.

The time period for reply, if any, is set in the attached communication.



**DO NOT USE IN PALM PRINTER**

(THIRD PARTY REQUESTER'S CORRESPONDENCE ADDRESS)

KENYON & KENYON LLP

ONE BROADWAY

NEW YORK, NY 10004

***EX PARTE* REEXAMINATION COMMUNICATION TRANSMITTAL FORM**

REEXAMINATION CONTROL NO. 90/013,252.

PATENT NO. 5,954,781.

ART UNIT 3992.

Enclosed is a copy of the latest communication from the United States Patent and Trademark Office in the above identified *ex parte* reexamination proceeding (37 CFR 1.550(f)).

Where this copy is supplied after the reply by requester, 37 CFR 1.535, or the time for filing a reply has passed, no submission on behalf of the *ex parte* reexamination requester will be acknowledged or considered (37 CFR 1.550(g)).



<b>Office Action in Ex Parte Reexamination</b>	<b>Control No.</b> 90/013,252	<b>Patent Under Reexamination</b> 5,954,781	
	<b>Examiner</b> DAVID ENGLAND	<b>Art Unit</b> 3992	<b>AIA (First Inventor to File) Status</b> No

**-- The MAILING DATE of this communication appears on the cover sheet with the correspondence address --**

- a.  Responsive to the communication(s) filed on 06/27/2014.  
 A declaration(s)/affidavit(s) under **37 CFR 1.130(b)** was/were filed on \_\_\_\_\_.
- b.  This action is made FINAL.
- c.  A statement under 37 CFR 1.530 has not been received from the patent owner.

A shortened statutory period for response to this action is set to expire \_\_\_\_\_ month(s) from the mailing date of this letter. Failure to respond within the period for response will result in termination of the proceeding and issuance of an *ex parte* reexamination certificate in accordance with this action. 37 CFR 1.550(d). **EXTENSIONS OF TIME ARE GOVERNED BY 37 CFR 1.550(c)**. If the period for response specified above is less than thirty (30) days, a response within the statutory minimum of thirty (30) days will be considered timely.

**Part I THE FOLLOWING ATTACHMENT(S) ARE PART OF THIS ACTION:**

- |   |   |
|---|---|
| 1. <input type="checkbox"/> Notice of References Cited by Examiner, PTO-892.        | 3. <input type="checkbox"/> Interview Summary, PTO-474. |
| 2. <input checked="" type="checkbox"/> Information Disclosure Statement, PTO/SB/08. | 4. <input type="checkbox"/> _____.                      |

**Part II SUMMARY OF ACTION**

- 1a.  Claims 1, 2, 4, 5, 7, 8, 10, 12, 13, 15, and 17-32 are subject to reexamination.
- 1b.  Claims 3, 6, 9, 11, 14 and 16 are not subject to reexamination.
2.  Claims \_\_\_\_\_ have been canceled in the present reexamination proceeding.
3.  Claims 1, 2, 4, 5, 7, 8, 10, 12, 13, 15, and 17-30 are patentable and/or confirmed.
4.  Claims 31, 32 are rejected.
5.  Claims \_\_\_\_\_ are objected to.
6.  The drawings, filed on \_\_\_\_\_ are acceptable.
7.  The proposed drawing correction, filed on \_\_\_\_\_ has been (7a)  approved (7b)  disapproved.
8.  Acknowledgment is made of the priority claim under 35 U.S.C. § 119(a)-(d) or (f).  
a)  All b)  Some\* c)  None of the certified copies have  
1  been received.  
2  not been received.  
3  been filed in Application No. \_\_\_\_\_ .  
4  been filed in reexamination Control No. \_\_\_\_\_ .  
5  been received by the International Bureau in PCT application No. \_\_\_\_\_ .
- \* See the attached detailed Office action for a list of the certified copies not received.
9.  Since the proceeding appears to be in condition for issuance of an *ex parte* reexamination certificate except for formal matters, prosecution as to the merits is closed in accordance with the practice under *Ex parte* Quayle, 1935 C.D. 11, 453 O.G. 213.
10.  Other: \_\_\_\_\_

cc: Requester (if third party requester)

## DETAILED EX PARTE REEXAMINATION NON-FINAL OFFICE ACTION

### I. INTRODUCTION

This is a first Non-Final Office Action on the merits in the *Ex Parte* Reexamination of claims 1, 2, 4, 5, 7, 8, 10, 12, 13, 15, and 17 – 32 of US Patent No. US 5,954,781 to Slepian et al., hereinafter “the ‘781 Patent”.

The present application is being examined under the pre-AIA first to invent provisions.

#### *A. References Cited in this Office Action*

1. The prior art patents and/or printed publications, hereinafter “the references”, which have been submitted 08/22/2014, have been considered and are relied upon in this Office Action are relisted as follows.

- a. Automotive Electronics Handbook, by Ronald Jurgen (“Jurgen”).
- b. U.S. Patent No. 5,477,452 to Milunas et al. (“Saturn ‘452”).
- c. U.S. Patent No. 4,559,599 to Habu et al. (“Toyota ‘599”).
- d. German Patent Application Publication No. 29 26 070 (“Volkswagen ‘070”).
- e. U.S. Patent No. 5,357,438 to Davidian (“Davidian”).
- f. PCT Publication No. WO 96/02853 (“Tonkin”).

## II. REJECTIONS

### A. Relevant Statutes – Claim Rejections

#### 1. *Claim Rejections - 35 USC § 102*

The following is a quotation of the appropriate paragraphs of pre-AIA 35 U.S.C. 102 that form the basis for the rejections under this section made in this Office action:

A person shall be entitled to a patent unless –

(b) the invention was patented or described in a printed publication in this or a foreign country or in public use or on sale in this country, more than one year prior to the date of application for patent in the United States.

#### 2. *Claim Rejections - 35 USC § 103*

The following is a quotation of pre-AIA 35 U.S.C. 103(a) which forms the basis for all obviousness rejections set forth in this Office action:

(a) A patent may not be obtained though the invention is not identically disclosed or described as set forth in section 102 of this title, if the differences between the subject matter sought to be patented and the prior art are such that the subject matter as a whole would have been obvious at the time the invention was made to a person having ordinary skill in the art to which said subject matter pertains. Patentability shall not be negated by the manner in which the invention was made.

### B. Detailed Analysis of the Rejection

The Examiner will use the shorthand notation of “1:1-5” for Column 1, lines 1-5.

1. Claim **31** is rejected under **pre-AIA 35 U.S.C. 102(b)** as being unpatentable over U.S. Patent No. 5,357,438 to Davidian, hereinafter “**Davidian**”.

RE: Claim 31

**Apparatus for optimizing operation of a vehicle, comprising:**

Davidian discloses an invention relating to an anti-collision system for vehicles. Therefore, preventing a vehicle from colliding with an object could result in the vehicle operating optimally.

**a radar detector, said radar detector determining a distance separating a vehicle having an engine and an object in front of said vehicle;**

It is seen in the '781 Patent the "radar detector" or as also stated in the specification, "radar device", is not specifically defined. It only states what its function. Davidian discloses such a device, "Vehicle 2 further includes a front space sensor 8 for sensing the space in front of the vehicle, such as the presence of another vehicle, a corresponding rear space sensor 10, and a pair of side sensors 11. All the space sensors are in the form of pulse (e.g., ultrasonic) transmitters and receivers, for determining the distance of the vehicle from an object, e.g., another vehicle, at front or rear. Space sensors may also be provided at the sides of the vehicle. Vehicle 2 is further equipped with a speed sensor 12 which may sense the speed of the vehicle in any known manner, for example using the speed measuring system of the vehicle itself, or a speed measuring system independent of the vehicle, e.g., an acceleration sensor, or by calculations based on the Doppler effect, etc.", (e.g., Davidian, 4:52-66).

Davidian further discloses, "FIG. 7 is a circuit diagram of the microcomputer 4 and the other components of the electrical system. The microprocessor is indicated by block 100, its power supply by block 102, and its watchdog circuit by block 104. It includes a **transmitter 106** and a **receiver 108** for transmitting and receiving the pulses (e.g., RF, ultrasound, laser, IR, etc.) in the front space sensor 8 and the rear space sensor 10 for measuring the distance of the vehicle

Art Unit: 3992

from objects in front of and to the rear, of the vehicle, respectively.", (e.g., Davidian, 10:17 – 26).

Davidian further discloses, "As indicated earlier, the distance of the vehicle from an object is determined by the front space sensor 8 with respect to objects in front of the vehicle, and by the rear space sensor 10 with respect to objects at the rear of the vehicle. Each of these space sensors may be of known construction, including a transmitter as indicated at 106 in FIG. 7, and a receiver as indicated at 108. Thus, pulses are continuously transmitted by each transmitter, and the echoes from the objects in front of or to the rear of the vehicle are received by the respective receiver. The computer then measures the round-trip time from the pulse transmission to the echo reception in order to determine the distance of the vehicle from the object.", (e.g., Davidian, 10:38 – 50).

**at least one sensor coupled to said vehicle for monitoring operation thereof, said at least one sensor including a road speed sensor;**

Davidian discloses "Vehicle 2 is further equipped with a speed sensor 12 which may sense the speed of the vehicle in any known manner, for example using the speed measuring system of the vehicle itself, or a speed measuring system independent of the vehicle, e.g., an acceleration sensor, or by calculations based on the Doppler effect, etc," (e.g. Davidian, 4:60 – 66).

**a processor subsystem, coupled to said radar detector and said at least one sensor, to receive data therefrom;**

Davidian discloses, "FIGS. 6a, 6b, are a block diagram illustrating the microcomputer 4 and its inputs and outputs described earlier which enable it to continuously monitor the operation of the vehicle and to actuate first a Safety alarm, and then a Collision alarm whenever the vehicle may enter a danger-of-collision situation according to the various preset parameters and automatic parameters introduced into the computer. The microcomputer 4 as illustrated in FIGS. 6a, 6b is divided into various functional modules, as follows: a calculation module 90, which receives data concerning the various parameters briefly described above and as will be described more particularly below to enable it to make the necessary computations for actuating the Safety alarm and the Collision alarm.", (e.g., Davidian, 8:29 – 43). "Thus, module 90 receives inputs from the front space sensor 8, the rear space sensor 10, and the vehicle speed sensor 12.", (e.g., Davidian 8:58 – 60).

E.g., Davidian, Figure 6A:

E.g., Davidian, Figure 6B:

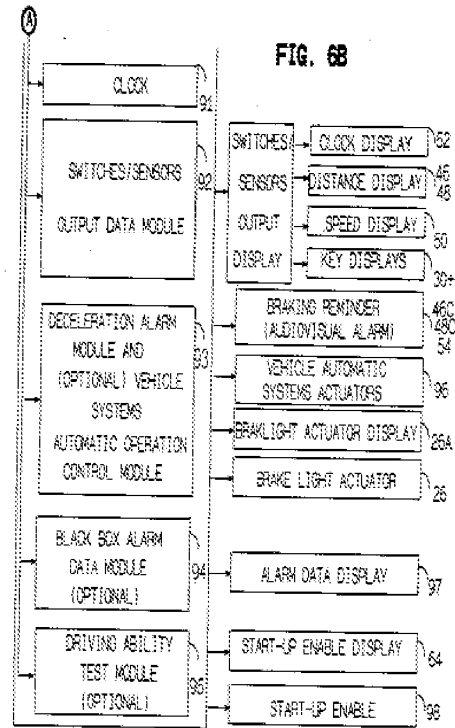
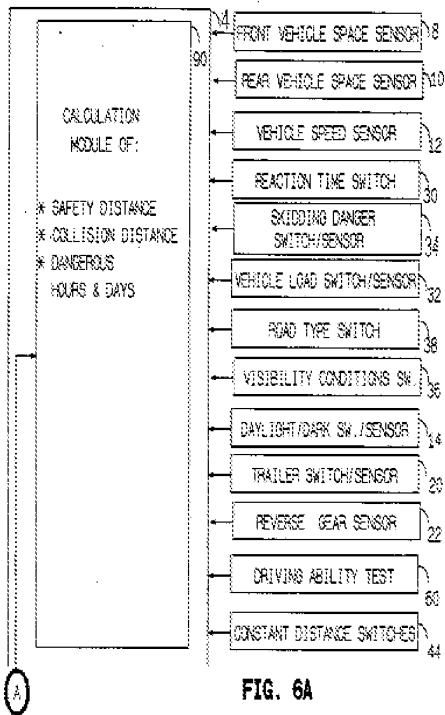

a memory subsystem, coupled to said processor subsystem, said memory subsystem storing a first vehicle speed/stopping distance table;

Davidian discloses "Computer module 90 also includes information about the vehicle braking distances as a function of speed. This is preferably in the form of a look-up table, for example, provided by the manufacturer for predetermined defined conditions concerning road type, skidding danger, vehicle load and tires pressure, and is stored in a ROM (read-only memory) of the microcomputer so that it can be changed periodically if necessary.", (e.g., Davidian, 9:20 – 27).

"The system then makes the computations illustrated (as an example) in block 162 to determine the stopping distance SD, which is equal to the reaction distance plus the braking distance multiplied by a stopping factor ST and a safety factor SF. In the illustrated example, the stopping distance is the sum of the reaction distance and the braking distance. The reaction distance is the product of the reaction time, visibility condition, daylight condition, reaction factor and **speed**; and the braking distance is the product of the braking distance (as supplied by the manufacturer), road type, skidding danger, vehicle load and braking factor. The stopping distance (SD) includes further safety factors, and determines when the safety alarm will be actuated to first alert the driver of an approaching collision danger. A determination is also made of the collision distance CD which is equal to the stopping distance SD divided by the collision safety factor CSF, e.g., 1.25 in the example illustrated above, such that should the distance between the vehicle and the object come within the collision distance CD, the collision alarm is then actuated. The foregoing calculations of stopping distance SD and collision distance CD with respect to objects at the front of the vehicle are also made with respect to objects at the rear of the vehicle, these calculations being RSD and RCD, respectively, also shown in block 162. Whenever the distance between the vehicle and an object to the front of the vehicle or to the rear of the vehicle comes within the stopping distance SD and the collision distance CD, the system operates according to the deceleration alarm module 93, as indicated by block 164.", (e.g., Davidian, 12:59 – 13:22).



**a vehicle proximity alarm circuit coupled to said processor subsystem, said vehicle proximity alarm circuit issuing an alarm that said vehicle is too close to said object;**

Jurgen discloses an, "anti-collision system illustrated in FIGS. 1-14 is particularly useful for motor vehicles (passengers cars, buses, trucks) in order to actuate an alarm when the vehicle is travelling at a distance behind another vehicle or in front of another, which is equal to or less than a danger-of-collision distance computed by a computer such that if the front vehicle stops suddenly there is a danger of a rear-end collision.", (e.g., Davidian, 3:59 – 66).

"In the system described below, there are two alarms: a Collision alarm, which is actuated when the vehicle is determined to be within the danger-of- collision distance; and a Safety alarm, which is actuated before the Collision alarm, at a distance greater than the danger-of-collision distance by a predetermined safety factor, e.g., 1.25.", (e.g., Davidian, 4:14 – 16).

"Control panel 6 further includes a front distance display 46, in which are displayed the distance to the front vehicle (in region 46a), in which direction (by arrow 46b), and whether or not there is a collision danger (region 46c).", (e.g., Davidian, 6:25 – 29).

"Control panel 6 further includes a speaker 54 for producing an audio alarm in the event of a collision danger, in addition to the visually-indicated alarms of sections 46c and 48c of the displays 46 and 48.", (e.g., Davidian, 6:41 – 46).

"The microcomputer 4 as illustrated in FIGS. 6a, 6b is divided into various functional modules, as follows: ... a deceleration alarm module 93, which controls the Safety alarm and Collision alarm on the control panel, ...", (e.g., Davidian, 8:37 – 48, and Figs. 3, (ref. no. 46 & 48) and 6B, (ref. no. 46C & 48C).

**said processor subsystem determining whether to activate said vehicle proximity alarm circuit based upon separation distance data received from said radar detector, vehicle speed data received from said road speed sensor and said first vehicle speed/stopping distance table stored in said memory subsystem.**

Jurgen discloses a, "microcomputer 4 as illustrated in FIGS. 6a, 6b is divided into various functional modules, as follows: a calculation module 90, which receives data concerning the various parameters briefly described above and as will be described more particularly below to enable it to make the necessary computations for actuating the Safety alarm and the Collision alarm; ...", (e.g., Davidian, 8:37 – 43).

"Computer module 90 also includes information about the vehicle braking distances as a function of speed. This is preferably in the form of a look-up table, for example, provided by the manufacturer for predetermined defined conditions concerning road type, skidding danger, vehicle load and tires pressure, and is stored in a ROM (read-only memory) of the microcomputer so that it can be changed periodically if necessary.", (e.g., Davidian, 9:20 – 27).

"The system then makes the computations illustrated (as an example) in block 162 to determine the stopping distance SD, which is equal to the reaction distance plus the braking distance multiplied by a stopping factor ST and a safety factor SF. In the illustrated example, the stopping distance is the sum of the reaction distance and the braking distance. The reaction distance is the product of the reaction time, visibility condition, daylight condition, reaction factor and **speed**; and the braking distance is the product of the braking distance (as supplied by the manufacturer), road type, skidding danger, vehicle load and braking factor. The stopping distance (SD) includes further safety factors, and determines when the safety alarm will be

Art Unit: 3992

actuated to first alert the driver of an approaching collision danger. A determination is also made of the collision distance CD which is equal to the stopping distance SD divided by the collision safety factor CSF, e.g., 1.25 in the example illustrated above, such that should the distance between the vehicle and the object come within the collision distance CD, the collision alarm is then actuated”, (e.g., Davidian, 12:59 – 13:11).

"Whenever the distance between the vehicle and an object to the front of the vehicle or to the rear of the vehicle comes within the stopping distance SD and the collision distance CD, the system operates according to the deceleration alarm module 93, as indicated by block 164.", (e.g., Davidian, 13:17 – 22).

2. Claim **32** is rejected under **pre-AIA 35 U.S.C. 103(a)** as being unpatentable over **Davidian** in view of PCT Publication No. WO 96/02853 to Tonkin, hereinafter “**Tonkin**”.

RE: Claim 32

**Apparatus for optimizing operation of a vehicle according to claim 31 wherein:**

Davidian discloses such as explained above in independent claim 31.

**said at least one sensor further includes a windshield wiper sensor for indicating whether a windshield wiper of said vehicle is activated; and**

The Requester points out in the request, page that:

During prosecution of the '781 Patent, the Applicants stated that "the windshield wiper sensor [of claim 32] is **not** used to inform the operator as to whether the windshield wipers are on or off." Rather, according to the Applicants, "the sensor is used by the processor subsystem to classify road conditions as either 'dry' or 'wet'.", (e.g., Application 08/813,270, Response to Non-Final Office Action, dated 02/19/1999, page 12). When finding the specific teachings in the '781 Patent's specification, 9:35—47, it is seen that if the windshield wiper is off it is concluded that the vehicle is operated in "dry conditions" and selects a first speed/stopping distance table, if the windshield wiper are on it is concluded that the vehicle is operated in "wet conditions" and selects a second speed/stopping distance table. Therefore, 'off = dry' and 'on = wet'.

If the state of the wiper sensor 32 indicates that the windshield wiper is off, the processor subsystem 12 concludes that the vehicle is being operated in dry conditions and selects the speed/stopping distance table stored at the location 14c of the memory subsystem 14. If, however, the state of the wiper sensor 32 indicates that the windshield wiper is on, the processor subsystem 12 concludes that the vehicle is being operated in wet conditions and selects the speed/stopping distance table stored at the location 14d of the memory subsystem 14. From the selected speed/stopping distance table 14c or 14d, the processor subsystem 12 then retrieves the stopping distance for the speed at which the vehicle is travelling.

Therefore, under this interpretation, Davidian describes that the automatic sensors of the vehicle include a rain sensor 16, "The automatic sensors on vehicle 2 further include a daylight sensor 14, a rain sensor 16, a vehicle load sensor 18, a trailer-hitch sensor 20, and a reverse gear sensor 22.", (e.g., Davidian, 4:67 – 5:2), and, "Module 90 also receives inputs from the sensors in case there is no depressible key, e.g., the daylight sensor 14, the trailer sensor 20, the reverse gear sensor 22, the rain sensor 16, and the vehicle load sensor 18.", (e.g., Davidian, 8:58 – 63). (col. 4, line 67 to col. 5, line 2). Furthermore, Davidian discloses keys that if depressed would

Art Unit: 3992

take into consideration road conditions and alter parameters in determining braking distance, i.e.,

“slippery conditions of the road”, (e.g., Davidian, 5:54 – 66),

Control panel 6 includes two keys 34 indicating the condition of the road with respect to the danger of 55 skidding thereon by the vehicle. Thus, key 34a would be depressed to indicate a slippery condition of the road and therefore a high danger of skidding, whereas key 34b would be depressed to indicate an unslippery condition of the road (e.g., dry) and therefore a low danger of 60 skidding.

Two keys 36 on the control panel 6 indicate the visibility condition of the road. Thus, key 36a would be depressed where the visibility condition is high, whereas key 36b would be depressed where it is low, 65 e.g., because of fog, sandstorm, snow, etc.

and (e.g., Davidian, 9:20 – 27).

Computer module 90 also includes information about 66 the vehicle braking distances as a function of speed. This is preferably in the form of a look-up table, for example, provided by the manufacturer for predetermined defined conditions concerning road type, skid- 25 ding danger, vehicle load and tires pressure, and is stored in a ROM (read-only memory) of the microcomputer so that it can be changed periodically if necessary.

It can be interpreted that the activation of the key is much the same as activating a windshield wiper.

Tonkin describes that safe stopping distances can be adjusted for prevailing weather conditions, and that information regarding the weather may be obtained by the warning system controller ascertaining if the windscreen wipers are in use or have been in use recently due to rain (col. 18, lines 9 to 16). Thus, the combination of Davidian and Tonkin discloses a windshield wiper sensor for indicating whether a windshield wiper of the vehicle is activated, as described in claim 32. It would have been obvious to one of ordinary skill in the art at the time the invention was made to combine Tonkin with Davidian because adjusting what has been

predetermined determined as a safe stopping distance for a vehicle, based on road conditions, would aid in operating the vehicle in a safe manner and avoid potential dangerous instances.

**said memory subsystem further storing a second vehicle speed/ stopping distance table;**

Davidian discloses a look-up table for predetermined defined conditions, i.e., skidding danger as previously discussed. "Computer module 90 also includes information about the vehicle braking distances as a function of speed. This is preferably in the form of a look-up table, for example, provided by the manufacturer for predetermined defined conditions concerning road type, skidding danger, vehicle load and tires pressure, and is stored in a ROM (read-only memory) of the microcomputer so that it can be changed periodically if necessary.", (e.g., Davidian, 9:20 – 27). As previously stated, the skidding danger condition of Davidian is part of determining if the road conditions are wet or dry. Although not specifically stated, one may interpret the different "predetermined defined conditions" as other tables to be used when the determination is made that the road conditions fall under one of those categories.

Tonkin describes that "safe stopping distances can be adjusted for prevailing weather conditions, again by providing stored values according to weather and possibly for different severities of poor weather.", (e.g., Tonkin, 18:16 - 19). "The size of the enhanced safe distance and enlarged safety envelope will generally be predetermined so as to correspond to typical parameters appropriate for driving under adverse road conditions. These parameters may for example be stored in a look up table allowing the parameters to be determined from the signals received by the controller together with the parameters defining the normal safety envelope.",

Art Unit: 3992

(e.g., Tonkin, 3:25 – 32). Tonkin further discloses a “two level warning system can be provided wherein, a first warning, e.g. turn on all lamps 13, when a trailing vehicle 18 encroaches within the safe stopping distance of the subject vehicle 16 for poor weather, and a second warning e.g. flash all or some lamps 13, if the trailing vehicle encroaches within the safe stopping distance for good conditions, (e.g., Tonkin, 18:19 - 26).

Thus, the combination of Davidian and Tonkin discloses a memory subsystem storing a second vehicle speed/stopping distance table, as described in claim 32. It would have been obvious to one of ordinary skill in the art at the time the invention was made to combine Tonkin with Davidian because storing a second type of “look up table”, or multiple tables, would allow the system to operate in multiple types of driving conditions, i.e., road type, skidding danger, vehicle load and tires pressure, (e.g., Davidian, 9:20 – 27), prevailing weather conditions for different severities of poor weather., (e.g., Tonkin, 18:16 - 19).

**if said windshield wiper sensor indicates that said windshield wiper is deactivated, said processor subsystem determining whether to activate said vehicle proximity alarm circuit based upon data received from said radar detector, said road speed sensor and said first vehicle speed/stopping distance table stored in said memory subsystem;**

**AND**

**if said windshield wiper sensor indicates that said windshield wiper is activated, said processor subsystem determining whether to activate said vehicle proximity alarm circuit based upon data received from said radar detector, said road speed sensor**

**and said second vehicle speed/stopping distance table stored in said memory subsystem.**

As previously stated, in the rejection of claim 31, Davidian discloses said processor subsystem determining whether to activate said vehicle proximity alarm circuit based upon separation distance data received from said radar detector, vehicle speed data received from said road speed sensor and said first vehicle speed/stopping distance table stored in said memory subsystem, see the above rejection of claim 31. The noticeable difference in these limitations is the determination of whether or not the road conditions are wet or dry and utilizing the specific vehicle speed/stopping distance table accordantly.

As previously stated, Davidian describes that the automatic sensors of the vehicle include a rain sensor 16, "The automatic sensors on vehicle 2 further include a daylight sensor 14, a rain sensor 16, a vehicle load sensor 18, a trailer-hitch sensor 20, and a reverse gear sensor 22.", (e.g., Davidian, 4:67 – 5:2), and, "Module 90 also receives inputs from the sensors in case there is no depressible key, e.g., the daylight sensor 14, the trailer sensor 20, the reverse gear sensor 22, the rain sensor 16, and the vehicle load sensor 18.", (e.g., Davidian, 8:58 – 63). (col. 4, line 67 to col. 5, line 2). Furthermore, Davidian discloses keys that if depressed would take into consideration road conditions and alter parameters in determining braking distance, i.e., "slippery conditions of the road", (e.g., Davidian, 5:54 – 66). It can be interpreted that the activation of the key is much the same as activating a windshield wiper.

Tonkin describes that safe stopping distances can be adjusted for prevailing weather conditions, and that information regarding the weather may be obtained by the warning system



controller ascertaining if the windscreen wipers are in use or have been in use recently due to rain (col. 18, lines 9 to 16).

Tonkin further discloses a “two level warning system can be provided wherein, a first warning, e.g. turn on all lamps 13, when a trailing vehicle 18 encroaches within the safe stopping distance of the subject vehicle 16 for poor weather, and a second warning e.g. flash all or some lamps 13, if the trailing vehicle encroaches within the safe stopping distance for good conditions, (e.g., Tonkin, 18:19 - 26).

Thus, the combination of Davidian and Tonkin discloses a determination as to the road conditions and selecting a specific set of parameters, i.e., two or more “look up table”, based on the road condition, to utilize for sending an alert to the operator of the vehicle.

It would have been obvious to one of ordinary skill in the art at the time the invention was made to combine Tonkin with Davidian because selecting a specific set of parameters, “look up table”, or multiple tables, based on specific driving conditions would allow the system to adjusting what has been predetermined determined as a safe stopping distance for a vehicle being operating and avoid potential dangerous instances by warning the vehicle’s operator of a potential collision based on those specific set of parameters based on the road conditions, i.e., road type, skidding danger, vehicle load and tires pressure, (e.g., Davidian, 9:20 – 27), prevailing weather conditions for different severities of poor weather., (e.g., Tonkin, 18:16 - 19).

### III. STATEMENT OF REASONS FOR PATENTABILITY AND/OR CONFIRMATION

The following is an Examiner's statement of reasons for patentability and/or confirmation of the claims found patentable in this reexamination proceeding: The prior art of Jurgen, Saturn '452, Toyota '599, Volkswagen '070, Davidian, and Tonkin do not disclose, alone or in combination, the limitation of "a fuel overinjection notification circuit coupled to said processor subsystem, said fuel overinjection notification circuit issuing a notification that excessive fuel is being supplied to said engine of said vehicle", as stated in claims 1, 7, 13, 17, 23, 26, and 28 of the '781 Patent.

The '781 Patent teaches the overinjection notification circuit as being activated when there is excessive fuel being supplied to the vehicle's engine. This overinjection notification circuit is activated when said processor subsystem determines, based upon data received from said plurality of sensors, when to activate said fuel overinjection circuit, see claim 1 and similarly claimed limitations found in independent claims 7, 13, 17, 23, 26, and 28, and the teachings stated in the '781 Patent 12:64 – 13:35.

Jurgen discloses a fuel injection shut off which utilizes a threshold. This fuel shut off is activated when a threshold is reached. "During a deceleration transition, the fuel can be shut off by simply not providing a pulse width signal to the injector to minimize exhaust emissions and fuel consumption.", (e.g., Jurgen, page 12.22). "During coasting and braking, fuel consumption can be further reduced by shutting off the fuel until the engine speed decreases to slightly higher than the set idle speed. The ECU determines when fuel shutoff can occur by evaluating the throttle position, engine RPM, and vehicle speed.", (e.g., Jurgen, page 12.4). "Using the inputs of

Art Unit: 3992

engine RPM and vehicle speed to the electronic control unit, **thresholds** can be established for limiting these **variables with fuel cutoff. When the maximum speed is achieved, the fuel injectors are shut off. When the speed decreases below the threshold, fuel injection resumes.**", (e.g., Jurgen, page 12.14). "During transition to fuel cutoff, the ignition timing is retarded from its current setting to reduce engine torque and to assist in engine braking. The fuel is then shut off During the transition, the throttle bypass valve or the main throttle valve may remain open for a short period to allow fresh air to oxidize the remaining unburned HC and CO to further reduce exhaust emissions. During development of the fuel cutoff strategy, the advantage of reduced emission effects and catalyst temperature control must be balanced against driveability requirements. The use of fuel cutoff may change the perceived amount of engine braking felt by the driver. In addition, care must be taken to avoid a 'bump' feel when entering the fuel cutoff mode, due to the change in torque.", (e.g., Jurgen, page 12.17). Though, Jurgen does teach different sensor readings being used to tell the ECU when to shut off the fuel, the threshold of these values does not cause the engine to have excess fuel, i.e., their threshold prevents overinjection of fuel whereas the '781 Patent's thresholds allow the engine to reach a state of overinjection. Therefore, Jurgen does not disclose the fuel ever being **overinjected** because of the threshold that is used and does not teach the claimed limitation stated above with regards to **overinjection**.

Saturn '452 discloses, "A motor vehicle has a manual transmission and means for indicating to the operator a point in operation for upshifting to the next higher gear from the present gear. A method of determining the shift point is provided based upon actual operating

parameters of the motor vehicle effecting current wheel torque and predicted wheel torque in the next higher gear.", (e.g., Saturn '452, Abstract). "Shift indicators are commonly used on manual transmission vehicles to assist non-expert drivers in determining when it is appropriate to shift the transmission to a higher gear in order to maximize driving fuel economy.", (e.g., Saturn '452, 1:10 – 13). Saturn '452 further discloses a threshold value close to unity providing a shift point which achieves maximum fuel economy, but does not specifically disclose a "fuel overinjection notification circuit coupled to said processor subsystem, said fuel overinjection notification circuit issuing a notification that excessive fuel is being supplied to said engine of said vehicle" either alone or in combination with the References specifically discussed in this Reexam case.

Toyota '599 discloses performing shift-up and shift-down alerts based on different criteria, one of which includes fuel consumption. Each shift position corresponding to the optimum fuel consumption rate in accordance with various parameters calculated, (e.g., Toyota '599, 2:59 – 63). Toyota '599 further discloses, "The indicator 10 includes a shift-up indicating lamp 10a and a shift-down indicating lamp 10b", (e.g., Toyota '599, 2:64 – 3:3). "However, only when either one of the assumed fuel consumption rates above is better than the current fuel consumption rate  $B_e$ , the corresponding shift-up lamp or shift-down lamp in the indicator 10 is illuminated, thus indicating the necessity of the speed change operation.", (e.g., Toyota '599, 7:29 – 38). As seen, Toyota '599 does not disclose an overinjection notification based upon data received from said plurality of sensors.

Volkswagen '070 discloses, "a display of the rout-specific fuel consumption provide in a vehicle", (e.g., Volkswagen '070, p. 9 of English translation). Volkswagen '070 further discloses, "Looking initially at operating range I remote from full load, the desired output at a lower specific fuel consumption is able to be achieved after upshifting into the next higher gear, at an operating point that lies to the left of operating range I in the diagram of Figure 1. Accordingly, the device of the present invention generates a signal that asks the operator, i.e., normally the driver, to shift to a higher gear, which is indicated in Figure 1 by the upward pointing arrow within operating range I", (e.g., Volkswagen '070, pp. 6 – 7, English translation). Volkswagen '070 teachings are towards shifting the gears of an engine and not overinjection of fuel and alerting a driver that too much fuel is being supplied to the engine. Therefore, Volkswagen '070 does not disclose the limitation discussed above.

As to Davidian and Tonkin, as was previously seen in the Order, these reference were not the basis for the SNQ for the limitation regarding overinjection, see Order. Therefore, Davidian and Tonkin, alone or in combination with the above references, disclose, "a fuel overinjection notification circuit coupled to said processor subsystem, said fuel overinjection notification circuit issuing a notification that excessive fuel is being supplied to said engine of said vehicle".

Any comments considered necessary by PATENT OWNER regarding the above statement must be submitted promptly to avoid processing delays. Such submission by the patent owner should be labeled: "Comments on Statement of Reasons for Patentability and/or Confirmation" and will be placed in the reexamination file.

Claims 1, 2, 4, 5, 7, 8, 10, 12, 13, 15, and 17 – 30 are confirmed as patentable in this reexamination proceeding.

#### **IV. CONCLUSION**

##### **A. Submissions**

1. Information Disclosure Statement (IDS)

The IDS submission on 08/22/2014 has been considered. It is to be noted, however, that where patents, publications, and other such items of information are submitted by a party (patent owner or requester) in compliance with the requirements of the rules, the requisite degree of consideration to be given to such information will be limited by the degree to which the party filing the information citation has explained the content and relevance of the information. In instances, where no explanation of citations (items of information) is required and none is provided for an information citation, only a cursory review of that information is required. The examiner need only perform a cursory evaluation of each unexplained item of information, to the extent that he/she needs in order to determine whether he/she will evaluate the item further. If the cursory evaluation reveals the item not to be useful, the examiner may simply stop looking at it. This review may often take the form of considering the documents in the same manner as other

documents in Office search files are considered by the Examiner while conducting a search of the prior art in a proper field of search. The initials of the Examiner, in this proceeding, placed adjacent to the citations on the PTO/SB/08A or its equivalent, without an indication in the record to the contrary in the record, do not signify that the information has been considered by the Examiner any further than to the extent noted above. The same degree of consideration was provided for the references merely cited with the request but for which no explanation regarding the content and relevance of the information was provided. See MPEP 609, Chapter 0600, pages 192-193 of pages 1-197 - MPEP Eighth Edition, Revision 8 (July 2010). The examiner notes that due to the unusually large number of references cited, and the absence of any description of the relevance of the references, it should be assumed that only the most cursory review of the cited documents consistent with these guidelines has been performed. If applicant is aware of any information that might be of particular relevance, it should be pointed out in order to insure a higher degree consideration.

2. In order to ensure full consideration of any amendments, affidavits or declarations, or other documents as evidence of patentability, such documents must be submitted in response to this Office action. Submissions after the next Office action, which is intended to be a final action, will be governed by the requirements of 37 CFR 1.116, after final rejection and 37 CFR 41.33 after appeal, which will be strictly enforced.

**B. Extension of time**

Extensions of time under 37 CFR 1.136(a) will not be permitted in these proceedings because the provisions of 37 CFR 1.136 apply only to "an applicant" and not to parties in a reexamination proceeding. Additionally, 35 U.S.C. 305 requires that reexamination proceedings "will be conducted with special dispatch" (37 CFR 1.550(a)). Extensions of time in ex parte reexamination proceedings are provided for in 37 CFR 1.550(c). See MPEP § 2265.

### **C. Litigation Reminder**

The patent owner is reminded of the continuing responsibility under 37 CFR 1.565(a) to apprise the Office of any litigation activity, or other prior or concurrent proceeding, involving in the '781 Patent throughout the course of this reexamination proceeding. See MPEP §§ 2207, 2282 and 2286.

### **D. Amendment in Reexamination Proceedings**

Patent owner is notified that any proposed amendment to the specification and/or claims in this reexamination proceeding must comply with 37 CFR 1.530(d)-(j), must be formally presented pursuant to 37 CFR 1.530(d) - (j), and must contain any fees required by 37 CFR 1.20(c). See MPEP § 2234 and 2250(IV) for examples to assist in the preparation of proper proposed amendments in reexamination proceedings.

### **E. Service of Papers**

All correspondence related to this ExParte reexamination proceeding should be directed:



Art Unit: 3992

By EFS: Registered users may submit via the electronic filing system EFS-Web, at

<https://efs.uspto.gov/efile/myportal/efs-registered>

By Mail to: Mail Stop Ex Parte Reexam

Central Reexamination Unit

Commissioner for Patents

United States Patent & Trademark Office

P.O. Box 1450

Alexandria, VA 22313-1450

By FAX to: (571) 273-9900

Central Reexamination Unit

By hand: Customer Service Window

Randolph Building

401 Dulany Street

Alexandria, VA 22314

Telephone numbers for reexamination inquiries:

Reexamination and Amendment practice: (571) 272-7703

Central Reexamination Unit (CRU): (571) 272-7705

Application/Control Number: 90/013,252

Page 26

Art Unit: 3992

Any inquiry concerning this communication or earlier communications from the examiner, or as to the status of this proceeding, should be directed to the Central Reexamination Unit at telephone number (571) 272-7705.

/David E. England/  
Primary Examiner, Art Unit 3992

Conferees:

/Michael J. Yigdall/  
Primary Examiner, Art Unit 3992

/Fred Ferris/  
Acting SPRS CRU

<b>Search Notes</b>  	<b>Application/Control No.</b>  90013252	<b>Applicant(s)/Patent Under Reexamination</b>  5,954,781
	<b>Examiner</b>  DAVID ENGLAND	<b>Art Unit</b>  3992

CPC- SEARCHED		
Symbol	Date	Examiner

CPC COMBINATION SETS - SEARCHED		
Symbol	Date	Examiner

US CLASSIFICATION SEARCHED			
Class	Subclass	Date	Examiner

SEARCH NOTES		
Search Notes	Date	Examiner
Searched references in IDS	6/18/14	/DE/
Searched references in IDS	10/06/14	/DE/

INTERFERENCE SEARCH			
US Class/ CPC Symbol	US Subclass / CPC Group	Date	Examiner

	/DAVID ENGLAND/ Primary Examiner.Art Unit 3992
--	---

<b>Reexamination</b> 	<b>Application/Control No.</b> 90013252	<b>Applicant(s)/Patent Under Reexamination</b> 5,954,781
	<b>Certificate Date</b>	<b>Certificate Number</b>

<b>Requester Correspondence Address:</b>	<input type="checkbox"/> <b>Patent Owner</b>	<input checked="" type="checkbox"/> <b>Third Party</b>
KENYON & KENYON LLP ONE BROADWAY NEW YORK, NY 10004		

<b>LITIGATION REVIEW</b> <input type="checkbox"/>	/DE/ (examiner initials)	10/06/2014 (date)
<b>Case Name</b>		<b>Director Initials</b>
1:13cv8413 (OPEN)		
1:13cv8416 (OPEN)		
1:13cv8418 (OPEN)		
1:13cv8419 (OPEN)		
1:13cv8421 (OPEN)		

<b>COPENDING OFFICE PROCEEDINGS</b>	
<b>TYPE OF PROCEEDING</b>	<b>NUMBER</b>

/DAVID ENGLAND/ Primary Examiner.Art Unit 3992
---

Receipt date: 08/22/2014

Doc code: IDS

Doc description: Information Disclosure Statement (IDS) Filed

PTO/SB/08a (01-10)

Approved for use through 07/31/2012. OMB 0651-0031  
U.S. Patent and Trademark Office; U.S. DEPARTMENT OF COMMERCE

Under the Paperwork Reduction Act of 1995, no persons are required to respond to a collection of information unless it contains a valid OMB control number.

<b>INFORMATION DISCLOSURE STATEMENT BY APPLICANT ( Not for submission under 37 CFR 1.99)</b>	Application Number		90013252
	Filing Date		2014-05-22
	First Named Inventor	HARVEY SLEPIAN	
	Art Unit	3992	
	Examiner Name	England, David E.	
	Attorney Docket Number	1089-001	

U.S. PATENTS						Remove
Examiner Initial*	Cite No	Patent Number	Kind Code <sup>1</sup>	Issue Date	Name of Patentee or Applicant of cited Document	Pages, Columns, Lines where Relevant Passages or Relevant Figures Appear
	1	5954781		1999-21-09	Velocity Patent LLC.	
	2	5416698		1995-16-05	Ronald A. Hutchison	
	3	5498195		1996-12-03	Gregory R. White	
	4	3835819		1974-09-17	Anderson	
	5	3892483		1975-07-01	Säufferer	
	6	3925753		1975-12-09	Auman	
	7	4061055		1997-12-06	lizuka	
	8	4075892		1978-02-28	Burchkhardt	

ALL REFERENCES CONSIDERED EXCEPT WHERE LINED THROUGH. /DE/

Receipt date: 08/22/2014

**INFORMATION DISCLOSURE  
STATEMENT BY APPLICANT**  
( Not for submission under 37 CFR 1.99)

Application Number	90013252
Filing Date	2014-05-22
First Named Inventor	HARVEY SLEPIAN
Art Unit	3992
Examiner Name	England, David E.
Attorney Docket Number	1089-001

9	4097864		1978-06-27	Endo	
10	4208925		1980-06-24	Miller	
11	4221126		1980-09-09	Cordiano	
12	4250485		1981-02-10	Mostert	
13	4255789		1981-03-10	Hartford	
14	4271402		1981-06-02	Kastura	
15	4280358		1981-07-28	Henderson	
16	4286683		1981-09-01	Zeigner	
17	4398174		1983-08-09	Smith, Jr.	
18	4411174		1983-10-25	Yokoi	
19	4438423		1984-03-20	Stier	

Receipt date: 08/22/2014

**INFORMATION DISCLOSURE  
STATEMENT BY APPLICANT**  
( Not for submission under 37 CFR 1.99)

Application Number	90013252
Filing Date	2014-05-22
First Named Inventor	HARVEY SLEPIAN
Art Unit	3992
Examiner Name	England, David E.
Attorney Docket Number	1089-001

20	4439158		1984-03-27	Weber	
21	4439833		1984-03-27	Yamaguchi	
22	4459670		1984-07-10	Yamaguchi	
23	4492112		1995-01-08	Igarashi	
24	4542460		1985-09-17	Weber	
25	4546747		1985-10-15	Kobayashi	
26	4550596		1985-11-05	Ueda	
27	4555691		1985-11-26	Hosaka	
28	4559599		1985-12-17	Habu	
29	4570226		1986-02-11	Aussedat	
30	4604700		1986-08-05	Igarashi	

ALL REFERENCES CONSIDERED EXCEPT WHERE LINED THROUGH. /DE/

<b>INFORMATION DISCLOSURE STATEMENT BY APPLICANT</b> ( Not for submission under 37 CFR 1.99)	Application Number		90013252	
	Filing Date		2014-05-22	
	First Named Inventor	HARVEY SLEPIAN		
	Art Unit	3992		
	Examiner Name	England, David E.		
	Attorney Docket Number	1089-001		

	31	4622637		1986-11-11	Tomita	
	32	4631515		1986-12-23	Blee	
	33	4632543		1986-12-30	Endo	
	34	4677556		1987-06-30	Habu	
	35	4683455		1987-07-28	Kido	
	36	4701852		1987-10-20	Ulveland	
	37	4703304		1987-10-27	Muguruma	
	38	4712452		1987-12-15	Hibino	
	39	4723215		1988-02-02	Hibino	
	40	4731727		1988-03-15	Rauch	
	41	4748955		1988-06-07	Yonekawa	



<b>INFORMATION DISCLOSURE STATEMENT BY APPLICANT</b> ( Not for submission under 37 CFR 1.99)	Application Number		90013252	
	Filing Date		2014-05-22	
	First Named Inventor	HARVEY SLEPIAN		
	Art Unit	3992		
	Examiner Name	England, David E.		
	Attorney Docket Number	1089-001		

	42	4752883		1988-06-21	Asakura	
	43	4800859		1989-01-31	Sagisaka	
	44	4853673		1989-08-01	Kido	
	45	4868756		1989-09-19	Kawanabe	
	46	4885690		1989-12-05	Schimmel	
	47	4901701		1990-02-20	Chasteen	
	48	4945870		1990-08-07	Richeson	
	49	5014200		1991-05-07	Chundrik	
	50	5017916		1991-05-21	Londt	
	51	5053979		1991-10-01	Etoh	
	52	5113721		1992-05-19	Polly	

ALL REFERENCES CONSIDERED EXCEPT WHERE LINED THROUGH. /DE/

EFS Web 2.1.17

/David England/

10/14/2014

<b>INFORMATION DISCLOSURE STATEMENT BY APPLICANT</b> ( Not for submission under 37 CFR 1.99)	Application Number		90013252	
	Filing Date		2014-05-22	
	First Named Inventor	HARVEY SLEPIAN		
	Art Unit	3992		
	Examiner Name	England, David E.		
	Attorney Docket Number	1089-001		

	53	5123397		1992-06-23	Richeson	
	54	5155682		1992-10-13	Ninoyu	
	55	5157991		1992-10-27	Sumimoto	
	56	5165497		1992-11-24	Chi	
	57	5187935		1993-02-23	Akiyama	
	58	5209206		1993-05-11	Danno	
	59	5227784		1993-07-13	Masamori	
	60	5234071		1993-08-10	Kajiwara	
	61	5261382		1993-11-16	Nikolai	
	62	5278764		1994-01-11	lizuka	
	63	5302956		1994-04-12	Asbury	

ALL REFERENCES CONSIDERED EXCEPT WHERE LINED THROUGH. /DE/

/David England/

10/14/2014

Receipt date: 08/22/2014

**INFORMATION DISCLOSURE  
STATEMENT BY APPLICANT**  
( Not for submission under 37 CFR 1.99)

Application Number	90013252
Filing Date	2014-05-22
First Named Inventor	HARVEY SLEPIAN
Art Unit	3992
Examiner Name	England, David E.
Attorney Docket Number	1089-001

64	5357438		1994-10-18	Davidian	
65	5396426		1995-03-07	Hibino	
66	5410304		1995-04-25	Hahn	
67	5420792		1995-05-30	Butsuen	
68	5436835		1995-07-25	Emry	
69	5443594		1995-08-22	Takada	
70	5477452		1995-12-19	Milunas	
71	5483939		1996-01-16	Kamura	
72	5483945		1996-01-16	Kobayashi	
73	5521579		1996-05-28	Bernhard	
74	5530651		1996-06-25	Uemura	

ALL REFERENCES CONSIDERED EXCEPT WHERE LINED THROUGH. /DE/

<b>INFORMATION DISCLOSURE STATEMENT BY APPLICANT</b> ( Not for submission under 37 CFR 1.99)	Application Number		90013252	
	Filing Date		2014-05-22	
	First Named Inventor	HARVEY SLEPIAN		
	Art Unit	3992		
	Examiner Name	England, David E.		
	Attorney Docket Number	1089-001		

	75	5564999		1996-10-15	Bellinger	
	76	5572428		1996-11-05	Ishida	
	77	5574644		1996-11-12	Butsuen	
	78	5587908		1996-12-24	Kajiwara	
	79	5647647		1997-07-15	Kato	
	80	5659304		1997-08-19	Chakraborty	
	81	5708584		1998-01-13	Doi	
	82	5710565		1998-01-20	Shirai	
	83	5745870		1998-04-28	Yamamoto	
	84	5754968		1998-05-19	Hedstrom	
	85	5778856		1998-07-14	Okada	

ALL REFERENCES CONSIDERED EXCEPT WHERE LINED THROUGH. /DE/

EFS Web 2.1.17

/David England/

10/14/2014

<b>INFORMATION DISCLOSURE STATEMENT BY APPLICANT</b> ( Not for submission under 37 CFR 1.99)	Application Number		90013252	
	Filing Date		2014-05-22	
	First Named Inventor	HARVEY SLEPIAN		
	Art Unit	3992		
	Examiner Name	England, David E.		
	Attorney Docket Number	1089-001		

	86	5781103		1998-07-14	Gilling	
	87	5805103		1998-09-08	Doi	
	88	5845492		1998-12-08	Isobe et al.	
	89	5864285		1999-01-26	Wieder	
	90	5865265		1999-02-02	Matsumoto	
	91	5929784		1999-07-27	Kawaziri	
	92	5934399		1999-08-10	liboshi	
	93	5952939		1999-09-14	Nakazawa	
	94	6031484		2000-02-29	Bullinger	
	95	6058348		2000-05-02	Ohyama	
	96	6293738		2001-05-29	Wanielik	

EFS Web 2.1.17 ALL REFERENCES CONSIDERED EXCEPT WHERE LINED THROUGH. /DE/

/David England/

10/14/2014

<b>INFORMATION DISCLOSURE STATEMENT BY APPLICANT</b> ( Not for submission under 37 CFR 1.99)	Application Number		90013252	
	Filing Date		2014-05-22	
	First Named Inventor	HARVEY SLEPIAN		
	Art Unit	3992		
	Examiner Name	England, David E.		
	Attorney Docket Number	1089-001		

97	5067372		1991-11-26	Suzuki	
98	4719820		1988-01-19	Hibino et al.	
99	6497297		2002-12-24	Ebert et al.	
100	5226351		1993-07-13	Matsuoka et al.	
101	6345227		2002-02-06	Egawa et al.	
102	4132284		1979-01-02	Tomecek	
103	5460582		1995-10-24	Palansky et al.	
104	3671081		1972-06-20	Jania et al.	
105	6178370		2001-01-23	Zierolf	
106	5268692		1993-12-07	Grosch et al.	
107	5305663		1994-04-26	Leonard et al.	

ALL REFERENCES CONSIDERED EXCEPT WHERE LINED THROUGH. /DE/

Receipt date: 08/22/2014

**INFORMATION DISCLOSURE  
STATEMENT BY APPLICANT**  
( Not for submission under 37 CFR 1.99)

Application Number	90013252
Filing Date	2014-05-22
First Named Inventor	HARVEY SLEPIAN
Art Unit	3992
Examiner Name	England, David E.
Attorney Docket Number	1089-001

108	6294990		2001-09-25	Knoll et al.	
109	5644490		1997-07-01	Weber	
110	6070682		2000-06-06	Isogai et al.	
111	4308536		1981-12-29	Sims, Jr. et al.	
112	5775451		1998-07-07	Hull et al.	
113	5949346		1999-09-07	Suzuki et al.	
114	5341144		1994-08-23	Stove	
115	5544056		1996-08-06	Seireg et al.	
116	4916450		1990-04-10	Davis	
117	5754123		1998-05-19	Nashif et al.	
118	5808374		1998-09-15	Miller et al.	

ALL REFERENCES CONSIDERED EXCEPT WHERE LINED THROUGH. /DE/

<b>INFORMATION DISCLOSURE STATEMENT BY APPLICANT</b> ( Not for submission under 37 CFR 1.99)	Application Number		90013252	
	Filing Date		2014-05-22	
	First Named Inventor	HARVEY SLEPIAN		
	Art Unit	3992		
	Examiner Name	England, David E.		
	Attorney Docket Number	1089-001		

	119	6233515		2001-05-15	Engelman et al.	
	120	4463427		1984-07-31	Bonnetain et al.	
	121	3921749		1975-11-25	Kawada	
	122	6125320		2000-09-26	Hellmann et al.	
	123	4872051		1989-10-03	Dye	
	124	5673987		1997-10-07	Futschik et al.	
	125	5777563		1998-07-07	Minissale et al.	
	126	4796716		1989-01-10	Masuda	
	127	5074144		1991-12-24	Krofchalk et al.	
	128	2804160		1957-08-27	Rashid	
	129	5173859		1992-12-22	Deering	

ALL REFERENCES CONSIDERED EXCEPT WHERE LINED THROUGH. /DE/



<b>INFORMATION DISCLOSURE STATEMENT BY APPLICANT</b> ( Not for submission under 37 CFR 1.99)	Application Number		90013252	
	Filing Date		2014-05-22	
	First Named Inventor	HARVEY SLEPIAN		
	Art Unit	3992		
	Examiner Name	England, David E.		
	Attorney Docket Number	1089-001		

If you wish to add additional U.S. Patent citation information please click the Add button.							Add
<b>U.S.PATENT APPLICATION PUBLICATIONS</b>							Remove
Examiner Initial*	Cite No	Publication Number	Kind Code <sup>1</sup>	Publication Date	Name of Patentee or Applicant of cited Document	Pages,Columns,Lines where Relevant Passages or Relevant Figures Appear	
	1	20020000122	A1	2002-01-03	Reuter		

If you wish to add additional U.S. Published Application citation information please click the Add button.								Add
<b>FOREIGN PATENT DOCUMENTS</b>								Remove
Examiner Initial*	Cite No	Foreign Document Number <sup>3</sup>	Country Code <sup>2</sup> j	Kind Code <sup>4</sup>	Publication Date	Name of Patentee or Applicant of cited Document	Pages,Columns,Lines where Relevant Passages or Relevant Figures Appear	T <sup>5</sup>
	1	JP H05-248894	JP		1993-09-24	Okamoto Yoshiyuki		<input checked="" type="checkbox"/>
	2	H06-052499	JP		1994-02-25	Yamamura Toshihiro		<input checked="" type="checkbox"/>
	3	H06-227337	JP		1994-08-16	Imai Yasuo		<input checked="" type="checkbox"/>
	4	H06-242234	JP		1994-09-02	Maeda Kozo and Ueno Yasushi		<input checked="" type="checkbox"/>
	5	H06-247247	JP		1994-09-06	Imai Yasuo		<input checked="" type="checkbox"/>
	6	H06-298021	JP		1994-10-25	Sasaki Kazuya, Hashimoto Yoshiyuki, Imai Yasuo		<input checked="" type="checkbox"/>

ALL REFERENCES CONSIDERED EXCEPT WHERE LINED THROUGH. /DE/

Receipt date: 08/22/2014

**INFORMATION DISCLOSURE  
STATEMENT BY APPLICANT**  
( Not for submission under 37 CFR 1.99)

Application Number		90013252
Filing Date		2014-05-22
First Named Inventor	HARVEY SLEPIAN	
Art Unit	3992	
Examiner Name	England, David E.	
Attorney Docket Number	1089-001	

7	H07-075218	JP		1995-03-17	Takimoto Tadao and Shirai Tetsuyuki	<input checked="" type="checkbox"/>
8	H07-322415	JP		1995-12-08	Suzuki Akira	<input checked="" type="checkbox"/>
9	H08-005436	JP		1996-01-12	Fujieda Terumitsu	<input checked="" type="checkbox"/>
10	H08-212499	JP		1996-08-20	Izawa Kazuyuki	<input checked="" type="checkbox"/>
11	EP Appln. 0419399	EP		1991-03-27	Ariav	<input type="checkbox"/>
12	EP Appln. 0544468	EP		1993-06-02	Faibish	<input type="checkbox"/>
13	EP Appln. 0637525	EP		1995-02-08	Waffler	<input type="checkbox"/>
14	EP 0392953	EP		1996-08-28	Tresse	<input type="checkbox"/>
15	EP 0404353	EP		1994-08-03	Genise	<input type="checkbox"/>
16	EP 0549909	EP		1996-08-28	Kajiwata	<input type="checkbox"/>
17	DE Appln. 2164465	DE		1973-06-28	Borchardt	<input type="checkbox"/>

ALL REFERENCES CONSIDERED EXCEPT WHERE LINED THROUGH. /DE/  
EFS Web 2.1.17

/David England/

10/14/2014

Receipt date: 08/22/2014

**INFORMATION DISCLOSURE  
STATEMENT BY APPLICANT**  
( Not for submission under 37 CFR 1.99)

Application Number	90013252
Filing Date	2014-05-22
First Named Inventor	HARVEY SLEPIAN
Art Unit	3992
Examiner Name	England, David E.
Attorney Docket Number	1089-001

18	DE Appln. 2241427	DE		1974-03-21	Bernhard		<input type="checkbox"/>
19	DE Appln. 2926070	DE		1981-01-15	Fiala		<input type="checkbox"/>
20	DE Appln. 3115096	DE		1983-01-27	Dipl		<input type="checkbox"/>
21	DE Appln. 3642196	DE		1988-06-23	Langer		<input type="checkbox"/>
22	DE Appln. 4117534	DE		1992-03-12	Krenzin		<input type="checkbox"/>
23	DE Appln. 3249455	DE		1984-12-13	Meyer		<input type="checkbox"/>
24	DE Appln. 3912359	DE		1990-10-25	Lexen		<input type="checkbox"/>
25	DE Appln. 4003057	DE		1991-08-08	Huder		<input type="checkbox"/>
26	DE Appln. 4309606	DE		1994-09-29	Weishaupt		<input type="checkbox"/>
27	DE Appln. 4437365	DE		1996-05-02	Butscher		<input type="checkbox"/>
28	DE Appln. 4437678	DE		1996-05-02	Adomat		<input type="checkbox"/>

ALL REFERENCES CONSIDERED EXCEPT WHERE LINED THROUGH. /DE/  
EFS Web 2.1.17

/David England/ 10/14/2014

Receipt date: 08/22/2014

**INFORMATION DISCLOSURE  
STATEMENT BY APPLICANT**  
( Not for submission under 37 CFR 1.99)

Application Number	90013252
Filing Date	2014-05-22
First Named Inventor	HARVEY SLEPIAN
Art Unit	3992
Examiner Name	England, David E.
Attorney Docket Number	1089-001

29	DE 3325714	DE		1985-01-31	Lauer		<input type="checkbox"/>
30	GB Appln. 2173331	GB		1986-10-08	Ritchie		<input type="checkbox"/>
31	GB Appln. 2265062	GB		1993-09-15	Codd		<input type="checkbox"/>
32	GB Appln. 2291244	GB		1996-01-17	Tonkin		<input type="checkbox"/>
33	GB Appln. 2298045	GB		1996-08-21	Mulhall		<input type="checkbox"/>
34	JP 59109442	JP		1984-06-25	Tatsuno		<input type="checkbox"/>
35	JP 59188582	JP		1984-10-25	Todome		<input type="checkbox"/>
36	JP H04-213800	JP		1992-08-04	Hirano		<input type="checkbox"/>
37	JP H04-232130	JP		1992-08-20	Hirano		<input type="checkbox"/>
38	JP H04-242895	JP		1992-08-31	Umemoto		<input type="checkbox"/>
39	JP H04-242896	JP		1992-08-31	Hirano		<input type="checkbox"/>

ALL REFERENCES CONSIDERED EXCEPT WHERE LINED THROUGH. /DE/

Receipt date: 08/22/2014

**INFORMATION DISCLOSURE  
STATEMENT BY APPLICANT**  
( Not for submission under 37 CFR 1.99)

Application Number		90013252
Filing Date		2014-05-22
First Named Inventor	HARVEY SLEPIAN	
Art Unit	3992	
Examiner Name	England, David E.	
Attorney Docket Number	1089-001	

40	JP H04-242900	JP		1992-08-31	Nakamura		<input type="checkbox"/>
41	WO 90/010210	WO		1990-09-07	Dickey		<input type="checkbox"/>
42	WO 91/007672	WO		1991-05-30	Montague		<input type="checkbox"/>
43	WO 92/021116	WO		1992-11-26	Needham		<input type="checkbox"/>
44	WO 96/002853	WO		1996-02-01	Tonkin		<input type="checkbox"/>
45	WO 96/014591	WO		1996-05-17	Rashid		<input type="checkbox"/>
46	WO 96/020336	WO		1996-07-04	Murakami		<input type="checkbox"/>
47	GB Appln. 2265341	GB		1993-09-22	Nocker et al.		<input type="checkbox"/>
48	DE 27 48 227 A1	DE		1977-10-27	Weickmann et al.		<input type="checkbox"/>
49	WO 00/21773	WO		2000-04-20	Ebert et al.		<input type="checkbox"/>
50	GB Appln. 2135387	GB		1984-08-30	Stelter et al.		<input type="checkbox"/>

ALL REFERENCES CONSIDERED EXCEPT WHERE LINED THROUGH. /DE/  
EFS Web 2.1.17

/David England/

10/14/2014

<b>INFORMATION DISCLOSURE STATEMENT BY APPLICANT</b> ( Not for submission under 37 CFR 1.99)	Application Number		90013252
	Filing Date		2014-05-22
	First Named Inventor	HARVEY SLEPIAN	
	Art Unit		3992
	Examiner Name	England, David E.	
	Attorney Docket Number		1089-001

If you wish to add additional Foreign Patent Document citation information please click the Add button			Add
NON-PATENT LITERATURE DOCUMENTS			Remove
Examiner Initials*	Cite No	Include name of the author (in CAPITAL LETTERS), title of the article (when appropriate), title of the item (book, magazine, journal, serial, symposium, catalog, etc), date, pages(s), volume-issue number(s), publisher, city and/or country where published.	T <sup>5</sup>
	1	BMW OF NORTH AMERICA, LLC & BMW MANUFACTURING CO., LLC, Case No. 13-CV-08416 Defendants' Local Patent Rule 2.3 Disclosures, BMW's Invalidity and Non-Infringement Contentions, U.S. District Court for the Northern District of Illinois Eastern Division, Fact Discovery, 2014-04-11, Chicago, Illinois.	<input type="checkbox"/>
	2	CHRYSLER GROUP LLC, Case No. 13-CV-08419 Defendant's Local Patent Rule 2.3 Disclosures, Chrysler's Invalidity and Non-Infringement Contentions, U.S. District Court for the Northern District of Illinois Eastern Division, Fact Discovery, 2014-04-11, Chicago, Illinois.	<input type="checkbox"/>
	3	JAGUAR LAND ROVER NORTH AMERICA, LLC, Case No. 13-CV-08421 Defendant's Local Patent Rule 2.3 Disclosures, Jaguar Land Rover's Invalidity and Non-Infringement Contentions, U.S. District Court for the Northern District of Illinois Eastern Division, Fact Discovery, 2014-04-11, Chicago, Illinois.	<input type="checkbox"/>
	4	MERCEDES-BENZ USA, LLC & MERCEDES-BENZ U.S. INTERNATIONAL INC., Case No. 13-CV-08413 Defendants' Local Patent Rule 2.3 Disclosures, Mercedes' Invalidity and Non-Infringement Contentions, U.S. District Court for the Northern District of Illinois Eastern Division, Fact Discovery, 2014-04-11, Chicago, Illinois.	<input type="checkbox"/>
	5	VELOCITY PATENT LLC, Case No. 13-CV-08416 Plaintiff's Local Patent Rule 2.5 Disclosures, Velocity's Initial Response to BMW's Invalidity Contentions, U.S. District Court for the Northern District of Illinois Eastern Division, Fact Discovery, 2014-05-12, Chicago, Illinois.	<input type="checkbox"/>
	6	VELOCITY PATENT LLC, Case No. 13-CV-08419 Plaintiff's Local Patent Rule 2.5 Disclosures, Velocity's Initial Response to Chrysler's Invalidity Contentions, U.S. District Court for the Northern District of Illinois Eastern Division, Fact Discovery, 2014-05-12, Chicago, Illinois.	<input type="checkbox"/>
	7	VELOCITY PATENT LLC, Case No. 13-CV-08419, Plaintiff's Local Patent Rule 2.5 Disclosures, Velocity's Initial Response to Jaguar Land Rover's Invalidity Contentions, U.S. District Court for the Northern District of Illinois Eastern Division, Fact Discovery, 2014-05-12, Chicago, Illinois.	<input type="checkbox"/>
	8	VELOCITY PATENT LLC, Case No. 13-CV-08413 Plaintiff's Local Patent Rule 2.5 Disclosures, Velocity's Initial Response to Mercedes' Invalidity Contentions, U.S. District Court for the Northern District of Illinois Eastern Division, Fact Discovery, 2014-05-12, Chicago, Illinois.	<input type="checkbox"/>
	9	AUDI OF AMERICA, INC., Case No. 13-CV-08418 Defedant's Local Patent Rule 2.3 Disclosures, Audi's Invalidity and Non-Infringement Contentions, U.S. District Court for the Northern District of Illinois Eastern Division, Fact Discovery, 2014-05-13, Chicago, Illinois.	<input type="checkbox"/>

ALL REFERENCES CONSIDERED EXCEPT WHERE LINED THROUGH. /DE/

<b>INFORMATION DISCLOSURE STATEMENT BY APPLICANT</b> ( Not for submission under 37 CFR 1.99)	Application Number		90013252
	Filing Date		2014-05-22
	First Named Inventor	HARVEY SLEPIAN	
	Art Unit	3992	
	Examiner Name	England, David E.	
	Attorney Docket Number	1089-001	

10	VELOCITY PATENT LLC, Case No. 13-CV-08418 Plaintiff's Local Patent Rule 2.5 Disclosures, Velocity's Initial Response to Audi's Invalidity Contentions, U.S. District Court for the Northern District of Illinois Eastern District, Fact Discovery, 2014-06-10, Chicago, Illinois.	<input type="checkbox"/>
11	VELOCITY PATENT LLC, Velocity's Response to Defendants' Common Interrogatories, U.S. District Court for the Northern District of Illinois Eastern Division, Fact Discovery, 2014-03-17, Chicago, Illinois.	<input type="checkbox"/>
12	VELOCITY PATENT LLC, Case No. 13-CV-08418 Velocity's Response to Audi's First Set of Interrogatories, U.S. District Court for the Northern District of Illinois Eastern Division, Fact Discovery, 2014-05-01, Chicago, Illinois.	<input type="checkbox"/>
13	AUDI OF AMERICA, INC., Case No. 13-CV-08418 Defendant's Objections and Responses to Velocity's First Set of Requests For Production (Nos. 1-47), U.S. District Court for the Northern District of Illinois Eastern Division, Fact Discovery, 2014-04-03, Chicago, Illinois.	<input type="checkbox"/>
14	AUDI OF AMERICA, INC., Defendant's Objections and Responses to Velocity's First Set of Interrogatories (Nos. 1-4), U.S. District Court for the Northern District of Illinois Eastern Division, Fact Discovery, 2014-04-03, Chicago, Illinois.	<input type="checkbox"/>
15	BMW OF NORTH AMERICA, LLC & BMW MANUFACTURING CO., LLC, Case No. 13-CV-08416 BMW's Objections and Responses to Velocity's First Set of Requests For Production (Nos. 1-47), U.S. District Court for the Northern District of Illinois Eastern Division, Fact Discovery, 2014-03-17, Chicago, Illinois.	<input type="checkbox"/>
16	BMW OF NORTH AMERICA, LLC & BMW MANUFACTURING CO., LLC, Case No. 13-CV-08416 BMW's Objections and Responses to Velocity's First Set Of Interrogatories (Nos. 1-3), U.S. District Court for the Northern District of Illinois Eastern Division, Fact Discovery, 2014-03-17, Chicago, Illinois.	<input type="checkbox"/>
17	BMW OF NORTH AMERICA, LLC & BMW MANUFACTURING CO., LLC, Case No. 13-CV-08416 BMW's Objections and Responses to Velocity's Second Set of Interrogatories (No. 4), U.S. District Court for the Northern District of Illinois Eastern Division, Fact Discovery, 2014-04-07, Chicago, Illinois.	<input type="checkbox"/>
18	BMW OF NORTH AMERICA, LLC & BMW MANUFACTURING CO., LLC, Case No. 13-CV-08416 BMW's First Supplemental Objections and Responses to Velocity's Second Set of Interrogatories (No. 4), U.S. District Court for the Northern District of Illinois Eastern Division, Fact Discovery, 2014-05-09, Chicago, Illinois.	<input type="checkbox"/>
19	CHRYSLER GROUP LLC, Case No. 13-CV-08419 Chrysler's Objections and Responses to Velocity's First Set Of Interrogatories (Nos. 1-3), U.S. District Court for the Northern District of Illinois Eastern Division, Fact Discovery, 2014-03-17, Chicago, Illinois.	<input type="checkbox"/>
20	CHRYSLER GROUP LLC, Case No. 13-CV-08419 Chrysler's Objections and Responses to Velocity's First Set of Requests For Production (Nos. 1-47), U.S. District Court for the Northern District of Illinois Eastern Division, Fact Discovery, 2014-03-17, Chicago, Illinois.	<input type="checkbox"/>

ALL REFERENCES CONSIDERED EXCEPT WHERE LINED THROUGH. /DE/

<b>Receipt date: 08/22/2014</b>  <b>INFORMATION DISCLOSURE STATEMENT BY APPLICANT</b> <b>( Not for submission under 37 CFR 1.99)</b>	Application Number		90013252
	Filing Date		2014-05-22
	First Named Inventor	HARVEY SLEPIAN	
	Art Unit	3992	
	Examiner Name	England, David E.	
	Attorney Docket Number	1089-001	

21	CHRYSLER GROUP LLC, Case No. 13-CV-08419 Chrysler's Objections and Responses to Velocity's Second Set of Interrogatories (No. 4), Case Discovery, 2014-04-07, Chicago, Illinois.	<input type="checkbox"/>
22	CHRYSLER GROUP LLC, Case No. 13-CV-08419 Chrysler's First Supplemental Objections and Responses to Velocity's First Set of Interrogatories (No. 1), Case Discovery, 2014-06-11, Chicago, Illinois.	<input type="checkbox"/>
23	CHRYSLER GROUP LLC, Case No. 13-CV-08419 Chrysler's First Supplemental Objections and Responses to Velocity's Second Set of Interrogatories (No. 4), Case Discovery, 2014-06-11, Chicago, Illinois.	<input type="checkbox"/>
24	JAGUAR LAND ROVER NORTH AMERICA, LLC, Case No. 13-CV-08419, Jaguar Land Rover's Objections and Responses to Velocity's First Set Of Interrogatories (Nos. 1-3), Case Discovery, 2014-03-17, Chicago, Illinois.	<input type="checkbox"/>
25	JAGUAR LAND ROVER NORTH AMERICA, LLC, Case No. 13-CV-08419, Jaguar Land Rover's Objections and Responses to Velocity's First Set of Requests For Production (Nos. 1-47), Case Discovery, 2014-03-17, Chicago, Illinois.	<input type="checkbox"/>
26	JAGUAR LAND ROVER NORTH AMERICA, LLC, Case No. 13-CV-08419, Jaguar Land Rover's Objections and Responses to Velocity's Second Set of Interrogatories (No. 4), Case Discovery, 2014-04-07, Chicago, Illinois.	<input type="checkbox"/>
27	JAGUAR LAND ROVER NORTH AMERICA, LLC, Case No. 13-CV-08419 Chrysler's First Supplemental Objections and Responses to Velocity's First Set of Interrogatories (No. 1), Case Discovery, 2014-06-06, Chicago, Illinois.	<input type="checkbox"/>
28	MERCEDES-BENZ USA, LLC, Case No. 13-CV-08413 Mercedes-Benz USA's Objections and Responses to Velocity's First Set Of Interrogatories (Nos. 1-3), Case Discovery, 2014-03-24, Chicago, Illinois.	<input type="checkbox"/>
29	MERCEDES-BENZ U.S. INTERNATIONAL INC., Case No. 13-CV-08413 Mercedes-Benz International's Objections and Responses to Velocity's First Set Of Interrogatories (Nos. 1-3), Case Discovery, 2014-03-24, Chicago, Illinois.	<input type="checkbox"/>
30	MERCEDES-BENZ USA, LLC, Case No. 13-CV-08413 Mercedes-Benz USA's Objections and Responses to Velocity's First Set of Requests For Production (Nos. 1-47), Case Discovery, 2014-03-24, Chicago, Illinois.	<input type="checkbox"/>
31	MERCEDES-BENZ U.S. INTERNATIONAL INC., Case No. 13-CV-08413 Mercedes-Benz International's Objections and Responses to Velocity's First Set of Requests For Production (Nos. 1-47), Case Discovery, 2014-03-24, Chicago, Illinois.	<input type="checkbox"/>

ALL REFERENCES CONSIDERED EXCEPT WHERE LINED THROUGH. /DE/



Receipt date: 08/22/2014

**INFORMATION DISCLOSURE  
STATEMENT BY APPLICANT**  
( Not for submission under 37 CFR 1.99)

Application Number		90013252
Filing Date		2014-05-22
First Named Inventor	HARVEY SLEPIAN	
Art Unit	3992	
Examiner Name	England, David E.	
Attorney Docket Number	1089-001	

32	MERCEDES-BENZ USA, LLC, Case No. 13-CV-08413 Mercedes-Benz USA's Objections and Responses to Velocity's Second Set of Interrogatories (No. 4), Case Discovery, 2014-04-14, Chicago, Illinois.	<input type="checkbox"/>
33	MERCEDES-BENZ U.S. INTERNATIONAL INC., Case No. 13-CV-08413 Mercedes-Benz International's Objections and Responses to Velocity's Second Set of Interrogatories (No. 4), Case Discovery, 2014-04-14, Chicago, Illinois.	<input type="checkbox"/>
34	VELOCITY PATENT LLC, Case No. 13-CV-08418 Docket # 1 Complaint For Patent Infringement to Audi of America, Inc. & Audi of America, LLC, U.S. District Court for the Northern District of Illinois Eastern Division, Case Complaint, 2013-11-21, Chicago, Illinois.	<input type="checkbox"/>
35	VELOCITY PATENT LLC, Case No. 13-CV-08418 Docket # 28 First Amended Complaint For Patent Infringement to Audi of America, Inc., U.S. District Court for the Northern District of Illinois Eastern Division, Case Complaint, 2014-01-30, Chicago, Illinois.	<input type="checkbox"/>
36	AUDI OF AMERICA, INC., Case No. 13-CV-08418 Docket # 23 Audi of America, Inc.'s Motion to Dismiss Velocity's Complaint for Failure to State a Claim, U.S. District Court for the Northern District of Illinois Eastern Division, Case Pleading, 2014-01-27, Chicago, Illinois.	<input type="checkbox"/>
37	AUDI OF AMERICA, INC., Case No. 13-CV-08418 Docket # 24 Audi of America, Inc.'s Brief in Support of their Motion to Dismiss Velocity's Complaint for Failure to State a Claim, U.S. District Court for the Northern District of Illinois Eastern Division, Case Pleading, 2014-01-27, Chicago, Illinois.	<input type="checkbox"/>
38	AUDI OF AMERICA, INC., Case No. 13-CV-08418 Docket # 36 Audi of America, Inc.'s Motion to Dismiss Velocity's First Amended Complaint for Failure to State a Claim, U.S. District Court for the Northern District of Illinois Eastern Division, Case Pleading, 2014-02-18, Chicago, Illinois.	<input type="checkbox"/>
39	AUDI OF AMERICA, INC., Case No. 13-CV-08418 Docket # 37 Audi of America, Inc.'s Memorandum in Support of its Motion to Dismiss Velocity's First Amended Complaint for Failure to State a Claim, U.S. District Court for the Northern District of Illinois Eastern Division, Case Pleading, 2014-02-18, Chicago, Illinois.	<input type="checkbox"/>
40	VELOCITY PATENT LLC, Case No. 13-CV-08418 Docket # 45 Velocity Patent LLC's Response to Defendant's Motion to Dismiss, U.S. District Court for the Northern District of Illinois Eastern Division, Case Pleading, 2014-03-19, Chicago, Illinois.	<input type="checkbox"/>
41	AUDI OF AMERICA, INC., Case No. 13-CV-08418 Docket # 47 Audi of America, Inc.'s Reply in Support of Its Motion to Dismiss Velocity's First Amended Complaint for Failure to State a Claim, U.S. District Court for the Northern District of Illinois Eastern Division, Case Pleading, 2014-02-04, Chicago, Illinois.	<input type="checkbox"/>
42	VELOCITY PATENT LLC, Case No. 13-CV-08416 Docket # 1 Complaint for Patent Infringement to BMW of North America, LLC & BMW Manufacturing Co., LLC, U.S. District Court for the Northern District of Illinois Eastern Division, Case Pleading, 2013-11-21, Chicago, Illinois.	<input type="checkbox"/>

ALL REFERENCES CONSIDERED EXCEPT WHERE LINED THROUGH. /DE/

<b>INFORMATION DISCLOSURE STATEMENT BY APPLICANT</b> ( Not for submission under 37 CFR 1.99)	Application Number		90013252
	Filing Date		2014-05-22
	First Named Inventor	HARVEY SLEPIAN	
	Art Unit	3992	
	Examiner Name	England, David E.	
	Attorney Docket Number	1089-001	

43	BMW OF NORTH AMERICA, LLC, Case No. 13-CV-08416 Docket # 21 BMW of North America's Answer and Counterclaim to Velocity's Complaint, U.S. District Court for the Northern District of Illinois Eastern Division, Case Pleading, 2014-01-27, Chicago, Illinois.	<input type="checkbox"/>
44	BMW MANUFACTURING CO., LLC, Case No. 13-CV-08416 Docket # 22 BMW Manufacturing's Answer and Counterclaim to Velocity's Complaint, U.S. District Court for the Northern District of Illinois Eastern Division, Case Pleading, 2014-01-27, Chicago, Illinois.	<input type="checkbox"/>
45	VELOCITY PATENT LLC, Case No. 13-CV-08416 Docket # 28 Velocity's Answer to Defendant BMW Manufacturing's Counterclaims, U.S. District Court for the Northern District of Illinois Eastern Division, Case Pleading, 2014-02-18, Chicago, Illinois.	<input type="checkbox"/>
46	VELOCITY PATENT LLC, Case No. 13-CV-08416 Docket # 29 Velocity's Answer to Defendant BMW of North America's Counterclaims, U.S. District Court for the Northern District of Illinois Eastern Division, Case Pleading, 2014-02-18, Chicago, Illinois.	<input type="checkbox"/>
47	VELOCITY PATENT LLC, Case No. 13-CV-08419 Docket # 1 Complaint for Patent Infringement to Chrysler Group LLC, U.S. District Court for the Northern District of Illinois Eastern Division, Case Pleading, 2013-11-21, Chicago, Illinois.	<input type="checkbox"/>
48	CHRYSLER GROUP LLC, Case No. 13-CV-08419 Docket # 24 Chrysler Group LLC's Anser to Velocity's Complaint, U.S. District Court for the Northern District of Illinois Eastern Division, Case Pleading, 2014-01-27, Chicago, Illinois.	<input type="checkbox"/>
49	VELOCITY PATENT LLC, Case No. 13-CV-08421 Docket # 1 Complaint for Patent Infringement to Jaguar Land Rover North America, LLC, U.S. District Court for the Northern District of Illinois Eastern Division, Case Pleading, 2013-11-21, Chicago, Illinois.	<input type="checkbox"/>
50	JAGUAR LAND ROVER NORTH AMERICA, LLC, Case No. 13-CV-08421 Docket #23 Jaguar Land Rover's Answer and Affirmative Defenses to Velocity's Original Complaint, U.S. District Court for the Northern District of Illinois Eastern Division, Case Pleading, 2014-01-27, Chicago, Illinois.	<input type="checkbox"/>

If you wish to add additional non-patent literature document citation information please click the Add button **Add**

**EXAMINER SIGNATURE**

Examiner Signature	/David England/	Date Considered	10/14/2014
--------------------	-----------------	-----------------	------------

\*EXAMINER: Initial if reference considered, whether or not citation is in conformance with MPEP 609. Draw line through a citation if not in conformance and not considered. Include copy of this form with next communication to applicant.

<sup>1</sup> See Kind Codes of USPTO Patent Documents at [www.USPTO.GOV](http://www.USPTO.GOV) or MPEP 901.04. <sup>2</sup> Enter office that issued the document, by the two-letter code (WIPO Standard ST.3). <sup>3</sup> For Japanese patent documents, the indication of the year of the reign of the Emperor must precede the serial number of the patent document. <sup>4</sup> Kind of document by the appropriate symbols as indicated on the document under WIPO Standard ST.16 if possible. <sup>5</sup> Applicant is to place a check mark here if English language translation is attached.

ALL REFERENCES CONSIDERED EXCEPT WHERE LINED THROUGH. /DE/

<b>INFORMATION DISCLOSURE STATEMENT BY APPLICANT</b> ( Not for submission under 37 CFR 1.99)	Application Number		90013252
	Filing Date		2014-05-22
	First Named Inventor	HARVEY SLEPIAN	
	Art Unit	3992	
	Examiner Name	England, David E.	
	Attorney Docket Number	1089-001	

**CERTIFICATION STATEMENT**

Please see 37 CFR 1.97 and 1.98 to make the appropriate selection(s):

That each item of information contained in the information disclosure statement was first cited in any communication from a foreign patent office in a counterpart foreign application not more than three months prior to the filing of the information disclosure statement. See 37 CFR 1.97(e)(1).

**OR**

That no item of information contained in the information disclosure statement was cited in a communication from a foreign patent office in a counterpart foreign application, and, to the knowledge of the person signing the certification after making reasonable inquiry, no item of information contained in the information disclosure statement was known to any individual designated in 37 CFR 1.56(c) more than three months prior to the filing of the information disclosure statement. See 37 CFR 1.97(e)(2).

- See attached certification statement.
- The fee set forth in 37 CFR 1.17 (p) has been submitted herewith.
- A certification statement is not submitted herewith.

**SIGNATURE**

A signature of the applicant or representative is required in accordance with CFR 1.33, 10.18. Please see CFR 1.4(d) for the form of the signature.

Signature	/Patrick D. Richards/	Date (YYYY-MM-DD)	2014-08-22
Name/Print	Patrick Richards	Registration Number	48905

This collection of information is required by 37 CFR 1.97 and 1.98. The information is required to obtain or retain a benefit by the public which is to file (and by the USPTO to process) an application. Confidentiality is governed by 35 U.S.C. 122 and 37 CFR 1.14. This collection is estimated to take 1 hour to complete, including gathering, preparing and submitting the completed application form to the USPTO. Time will vary depending upon the individual case. Any comments on the amount of time you require to complete this form and/or suggestions for reducing this burden, should be sent to the Chief Information Officer, U.S. Patent and Trademark Office, U.S. Department of Commerce, P.O. Box 1450, Alexandria, VA 22313-1450. **DO NOT SEND FEES OR COMPLETED FORMS TO THIS ADDRESS. SEND TO: Commissioner for Patents, P.O. Box 1450, Alexandria, VA 22313-1450.**

Receipt date: 08/22/2014

## Privacy Act Statement

The Privacy Act of 1974 (P.L. 93-579) requires that you be given certain information in connection with your submission of the attached form related to a patent application or patent. Accordingly, pursuant to the requirements of the Act, please be advised that: (1) the general authority for the collection of this information is 35 U.S.C. 2(b)(2); (2) furnishing of the information solicited is voluntary; and (3) the principal purpose for which the information is used by the U.S. Patent and Trademark Office is to process and/or examine your submission related to a patent application or patent. If you do not furnish the requested information, the U.S. Patent and Trademark Office may not be able to process and/or examine your submission, which may result in termination of proceedings or abandonment of the application or expiration of the patent.

The information provided by you in this form will be subject to the following routine uses:

1. The information on this form will be treated confidentially to the extent allowed under the Freedom of Information Act (5 U.S.C. 552) and the Privacy Act (5 U.S.C. 552a). Records from this system of records may be disclosed to the Department of Justice to determine whether the Freedom of Information Act requires disclosure of these records.
2. A record from this system of records may be disclosed, as a routine use, in the course of presenting evidence to a court, magistrate, or administrative tribunal, including disclosures to opposing counsel in the course of settlement negotiations.
3. A record in this system of records may be disclosed, as a routine use, to a Member of Congress submitting a request involving an individual, to whom the record pertains, when the individual has requested assistance from the Member with respect to the subject matter of the record.
4. A record in this system of records may be disclosed, as a routine use, to a contractor of the Agency having need for the information in order to perform a contract. Recipients of information shall be required to comply with the requirements of the Privacy Act of 1974, as amended, pursuant to 5 U.S.C. 552a(m).
5. A record related to an International Application filed under the Patent Cooperation Treaty in this system of records may be disclosed, as a routine use, to the International Bureau of the World Intellectual Property Organization, pursuant to the Patent Cooperation Treaty.
6. A record in this system of records may be disclosed, as a routine use, to another federal agency for purposes of National Security review (35 U.S.C. 181) and for review pursuant to the Atomic Energy Act (42 U.S.C. 218(c)).
7. A record from this system of records may be disclosed, as a routine use, to the Administrator, General Services, or his/her designee, during an inspection of records conducted by GSA as part of that agency's responsibility to recommend improvements in records management practices and programs, under authority of 44 U.S.C. 2904 and 2906. Such disclosure shall be made in accordance with the GSA regulations governing inspection of records for this purpose, and any other relevant (i.e., GSA or Commerce) directive. Such disclosure shall not be used to make determinations about individuals.
8. A record from this system of records may be disclosed, as a routine use, to the public after either publication of the application pursuant to 35 U.S.C. 122(b) or issuance of a patent pursuant to 35 U.S.C. 151. Further, a record may be disclosed, subject to the limitations of 37 CFR 1.14, as a routine use, to the public if the record was filed in an application which became abandoned or in which the proceedings were terminated and which application is referenced by either a published application, an application open to public inspections or an issued patent.
9. A record from this system of records may be disclosed, as a routine use, to a Federal, State, or local law enforcement agency, if the USPTO becomes aware of a violation or potential violation of law or regulation.

Receipt date: 08/22/2014

Doc code: IDS

Doc description: Information Disclosure Statement (IDS) Filed

PTO/SB/08a (01-10)

Approved for use through 07/31/2012. OMB 0651-0031  
U.S. Patent and Trademark Office; U.S. DEPARTMENT OF COMMERCE

Under the Paperwork Reduction Act of 1995, no persons are required to respond to a collection of information unless it contains a valid OMB control number.

<b>INFORMATION DISCLOSURE STATEMENT BY APPLICANT</b> ( Not for submission under 37 CFR 1.99)	Application Number	90013252
	Filing Date	2014-05-22
	First Named Inventor	HARVEY SLEPIAN
	Art Unit	3992
	Examiner Name	England, David E.
	Attorney Docket Number	1089-001

U.S. PATENTS							Remove
Examiner Initial*	Cite No	Patent Number	Kind Code <sup>1</sup>	Issue Date	Name of Patentee or Applicant of cited Document	Pages, Columns, Lines where Relevant Passages or Relevant Figures Appear	
	1						

If you wish to add additional U.S. Patent citation information please click the Add button.

Add

U.S. PATENT APPLICATION PUBLICATIONS							Remove
Examiner Initial*	Cite No	Publication Number	Kind Code <sup>1</sup>	Publication Date	Name of Patentee or Applicant of cited Document	Pages, Columns, Lines where Relevant Passages or Relevant Figures Appear	
	1						

If you wish to add additional U.S. Published Application citation information please click the Add button.

Add

FOREIGN PATENT DOCUMENTS								Remove
Examiner Initial*	Cite No	Foreign Document Number <sup>3</sup>	Country Code <sup>2</sup>	Kind Code <sup>4</sup>	Publication Date	Name of Patentee or Applicant of cited Document	Pages, Columns, Lines where Relevant Passages or Relevant Figures Appear	T <sup>5</sup>
	<u>51</u>	DE 32 18 243 A1	DE		1983-11-17	Lehnert et al.		<input type="checkbox"/>
	<u>52</u>	DE 32 45 752 A1	DE		1983-06-30	Vali-Llovera Passana et al.		<input type="checkbox"/>
	<u>53</u>	DE 32 28 516 A1	DE		1984-04-05	Meyer		<input type="checkbox"/>

ALL REFERENCES CONSIDERED EXCEPT WHERE LINED THROUGH. /DE/

SPC Form 2.1.17

/David England/

10/14/2014

Receipt date: 08/22/2014

<b>INFORMATION DISCLOSURE STATEMENT BY APPLICANT</b> ( Not for submission under 37 CFR 1.99)	Application Number	90013252
	Filing Date	2014-05-22
	First Named Inventor	HARVEY SLEPIAN
	Art Unit	3992
	Examiner Name	England, David E.
	Attorney Docket Number	

<u>54</u>	GB Appln. 2112945	GB		1983-07-27	Vall-Liovera Passana et al.	<input type="checkbox"/>
<u>55</u>	DE 43 26 182 A1	DE		1994-02-17	Schulze	<input type="checkbox"/>
<u>56</u>	DE 35 01 276 C2	DE		1989-07-27	Schimmel et al.	<input type="checkbox"/>
<u>57</u>	DE 32 26 829 A1	DE		1984-01-19	Stelter et al.	<input type="checkbox"/>
<u>58</u>	DE 195 47 375 A1	DE		1997-08-26	Knoll et al.	<input type="checkbox"/>
<u>59</u>	DE 198 47 611 A1	DE		2000-04-20	Heimermann et al.	<input type="checkbox"/>
<u>60</u>	DE 33 34 093 A1	DE		1985-04-11	Rauch	<input type="checkbox"/>
<u>61</u>	DE 29 32 240 A1	DE		1981-02-12	Bechtold et al.	<input type="checkbox"/>
<u>62</u>	DE 32 18 243 C2	DE		1984-04-05	Lehnert et al.	<input type="checkbox"/>
<u>63</u>	EP 0 484 995 A2	EP		1992-05-13	Deering	<input type="checkbox"/>
<u>64</u>	DE 35 01 276 A1	DE		1985-08-01	Schimmel et al.	<input type="checkbox"/>

EPSON 2117

ALL REFERENCES CONSIDERED EXCEPT WHERE LINED THROUGH. /DE/

/David England/

10/14/2014

Receipt date: 08/22/2014

<b>INFORMATION DISCLOSURE STATEMENT BY APPLICANT</b> ( Not for submission under 37 CFR 1.99)	Application Number	90013252
	Filing Date	2014-05-22
	First Named Inventor	HARVEY SLEPIAN
	Art Unit	3992
	Examiner Name	England, David E.
	Attorney Docket Number	

65	DE 196 46 104 C1	DE	1988-04-02	Hellmann et al.	<input type="checkbox"/>
66	DE 195 39 799 A1	DE	1996-05-09	Vieth	<input type="checkbox"/>

If you wish to add additional Foreign Patent Document citation information please click the Add button

**NON-PATENT LITERATURE DOCUMENTS**

Examiner Initials*	Cite No	Include name of the author (in CAPITAL LETTERS), title of the article (when appropriate), title of the item (book, magazine, journal, serial, symposium, catalog, etc), date, pages(s), volume-issue number(s), publisher, city and/or country where published.	T <sup>5</sup>
	51	VELOCITY PATENT LLC, Case No. 13-CV-08413 Docket # 1 Complaint for Patent Infringement to Mercedes-Benz USA, LLC & Mercedes-Benz U.S. International Inc., U.S. District Court for the Northern District of Illinois Eastern Division, Case Pleading, 2013-11-21, Chicago, Illinois	<input type="checkbox"/>
	52	MERCEDES-BENZ U.S. INTERNATIONAL, INC., 13-CV-08413 Docket # 34 Mercedes-Benz U.S. International's Answer, Affirmative Defenses, and Counterclaim to Velocity's Complaint, U.S. District Court for the Northern District of Illinois Eastern Division, Case Pleading, 2014-01-27, Chicago, Illinois.	<input type="checkbox"/>
	53	MERCEDES-BENZ USA, LLC, 13-CV-08413 Docket # 35 Mercedes-Benz USA's Answer, Affirmative Defenses, and Counterclaim to Velocity's Complaint, U.S. District Court for the Northern District of Illinois Eastern Division, Case Pleading, 2014-01-27, Chicago, Illinois.	<input type="checkbox"/>
	54	VELOCITY PATENT LLC, 13-CV-08413 Docket # 44 Velocity's Answer to Defendant Mercedes-Benz U.S. International's Counterclaim, U.S. District Court for the Northern District of Illinois Eastern Division, Case Pleading, 2014-02-18, Chicago, Illinois.	<input type="checkbox"/>
	55	VELOCITY PATENT LLC, 13-CV-08413 Docket # 45 Velocity's Answer to Defendant Mercedes-Benz USA's Counterclaim, U.S. District Court for the Northern District of Illinois Eastern District, Case Pleading, 2014-02-18, Chicago, Illinois.	<input type="checkbox"/>
	56	VELOCITY PATENT LLC, Velocity's Preliminary Infringement Contentions Against BMW Defendants Pursuant to Northern District of Illinois Local Patent Rule 2.1, U.S. District Court for the Northern District of Illinois Eastern District, Case Discovery, 2014-03-12, Chicago, Illinois.	<input type="checkbox"/>
	57	P. FANCHER, R. ERVIN, S. BOGARD, A Field Operational Test of Adaptive Cruise Control System Operability in Naturalistic Use, Technical Paper Series, 1998-02-23, 14 Pages, Society of Automotive Engineers, Inc. Technical Paper Series, Detroit, Michigan.	<input type="checkbox"/>

ALL REFERENCES CONSIDERED EXCEPT WHERE LINED THROUGH. /DE/

Receipt date: 08/22/2014

<b>INFORMATION DISCLOSURE STATEMENT BY APPLICANT</b> ( Not for submission under 37 CFR 1.99)	Application Number	90019252
	Filing Date	2014-05-22
	First Named Inventor	HARVEY SLEPIAN
	Art Unit	3992
	Examiner Name	England, David E.
	Attorney Docket Number	

58	P.A. IOANNOU, F. AHMED-ZAID, D.H. WUJH, A Time Headway Autonomous Intelligent Cruise Controller: Design and Simulation, Report, April 1994, 32 Pages, California PATH Program of the University of California.	<input type="checkbox"/>
59	GERHARD NÖCKER, Daimler-Benz AG, Abschlußbericht Prometheus Phase II, Study, 1989, 11 Pages, BMW, Daimler-Benz, FIAT, Jaguar, MAN, Matra, Opel, PSA, Renault, Saab, Volvo, VW, Germany	<input type="checkbox"/>
60	ROBERT D. ERVIN, ANU NAGARAJAN, EDWARD S. ARGALAS, Adaptive Cruise Control: An industry Outlook on Product Features and Marketing, Report, October 1997, 110 Pages, U.S. Dept. of Transportation and the University of Michigan ITS Research Center of Excellence.	<input type="checkbox"/>
61	HERMANN WINNER, STEFAN WITTE, WERNER UHLER, BERND LICHTENBERG, Adaptive Cruise Control System Aspects and Development Trends, Technical Paper, 1996-02-28, 12 Pages, Society of Automotive Engineers, Inc. Technical Paper Series, Detroit, Michigan.	<input type="checkbox"/>
62	D. HROVAT & J. JOHNSON, Title: Automotive Control Systems: Past, Present, Future, Paper, Date: September 1991, 6 Pages, Ford Motor Company.	<input type="checkbox"/>
63	Automotive Handbook 3rd Edition, Book, 1993, 51 Pages, ROBERT BOSCH GMBH, Stuttgart, Germany.	<input type="checkbox"/>
64	A. L. MERLO, Automotive Radar for the Prevention of Collisions, Technical Paper, 6 Pages, The Bendix Corporation Research Laboratories Division, Southfield, Michigan.	<input type="checkbox"/>
65	A. BASTIAN, P. ANDREAS, R. HOLZE and R. BERGHOLZ, Autonomous Cruise Control: A First Step Towards Automated Driving, Technical Paper, 1998-08-11, pp. 1-6, Society of Automotive Engineers Technical Paper Series.	<input type="checkbox"/>
66	GERHARD NÖCKER, Abstandsregelung Autonomous Intelligent Cruise Control, Paper, 1990, pp. 327-336, VDI Berichte.	<input type="checkbox"/>
67	RAY W. MURPHY, RUDOLF LIMPERT, LEONARD SEGEL, Bus, Truck, Tractor/Trailer Braking System Performance, Summary Final Report, January 1970, pp. 1-46, Highway Safety Research Institute and the University of Michigan.	<input type="checkbox"/>
68	M.J. RICHARDSON and DAVID SMITH, Design of the Driver Interface for Autonomous Intelligent Cruise Control, Colloquium, 1995-01-19, pp. 7/1-7/4, Colloquium on Design of the Driver Interface.	<input type="checkbox"/>

ALL REFERENCES CONSIDERED EXCEPT WHERE LINED THROUGH. /DE/

EFS Web 2.1.0

/David England/

10/14/2014



Receipt date: 08/22/2014

<b>INFORMATION DISCLOSURE STATEMENT BY APPLICANT</b> ( Not for submission under 37 CFR 1.99)	Application Number	90013252
	Filing Date	2014-05-22
	First Named Inventor	HARVEY SLEPIAN
	Art Unit	3992
	Examiner Name	England, David E.
	Attorney Docket Number	

<u>69</u>	PROF. DR. BERTHOLD FÄRBER, Designing a Distance Warning System From The User's Point of View, Report, 1991-02-28, pp.1-16, Institut für Arbeitspsychologie und interdisziplinäre Systemforschung.	<input type="checkbox"/>
<u>70</u>	JAMES E. STEVENS and LOUIS L. NAGY, Duplex Doppler Radar for Automotive Obstacle Detection, Technical Paper, May 1974, pp. 34-44, IEEE Transactions on Vehicular Technology.	<input type="checkbox"/>
<u>71</u>	K. NAAB and G. REICHART, Driver Assistance Systems for Lateral and Longitudinal Vehicle Guidance - Heading Control and Active Cruise Support, Symposium, 1994-10-25, pp. 1-6, International Symposium on Advanced Vehicle Control.	<input type="checkbox"/>
<u>72</u>	JACEK MALEC, MAGNUS MORIN, and ULF PALMQVIST, Driver Support in Intelligent Autonomous Cruise Control, Article, pp. 160-164, Driver Assistance and Local Traffic Management - Swedish RTI Research Program.	<input type="checkbox"/>
<u>73</u>	PETE TINKER, RONALD AZUMA, CHERYL HEIN, and MIKE DAILY, Driving Simulation for Crash Avoidance Warning Evaluation, Symposium, 1996-06-3, pp. 367-384, Proceedings of the 29th ISATA Dedicated Conference on Simulation, Diagnosis and Virtual Reality in the Automotive Industry.	<input type="checkbox"/>
<u>74</u>	PAUL S. FANCHER, ZEVI BAREKET, JAMES R. SAYER, GREGORY E. JOHNSON, ROBERT D. ERVIN, and MARY LYNN MEFFORD, Fostering Development, Evaluation and Deployment of Forward Crash Avoidance Systems (FOCAS), Annual Research Report, 1995-05-15, pp. 1-170, University of Michigan Transportation Research Institute.	<input type="checkbox"/>
<u>75</u>	PAUL S. FANCHER, ZEVI BAREKET, JAMES R. SAYER, GREGORY E. JOHNSON, ROBERT D. ERVIN, and MARY LYNN MEFFORD, Fostering Development, Evaluation and Deployment of Forward Crash Avoidance System (FOCAS), 1995-05-15, pp. 1-164, National Highway Traffic Safety Administration - U.S. Dept. of Transportation.	<input type="checkbox"/>
<u>76</u>	STEFAN ULVELAND and EYVIND STADIG, Increasing Mileage with an Adaptive Microprocessor Shift Indicator, Technical Paper, 1985-02-25, pp. 55-56, Society of Automotive Engineers Technical Paper Series.	<input type="checkbox"/>
<u>77</u>	P. FANCHER, R. ERVIN, J. SAYER, M. HAGAN, S. BOGARD, Z. BAREKET, M. MEFFORD, and J. HAUGEN, Intelligent Cruise Control Field Operational Test, Final Report, May 1998, pp. 1-558, U.S. Department of Transportation - National Highway Traffic Safety Administration.	<input type="checkbox"/>
<u>78</u>	ULF PALMQVIST, Intelligent Cruise Control: A Key Component Towards Improved Traffic Flow Control, Report, pp. 56-59.	<input type="checkbox"/>
<u>79</u>	J. GROGAN, D. A. MORRIS, S.W. SEARCY, and B.A. STOUT, Microcomputer-based Tractor Performance Monitoring and Optimization System, Journal, 1987, pp. 227-243, The British Society For Research in Agricultural Engineering.	<input type="checkbox"/>

EPG Web 2.1.17 ALL REFERENCES CONSIDERED EXCEPT WHERE LINED THROUGH. /DE/

/David England/

10/14/2014

Receipt date: 08/22/2014

**INFORMATION DISCLOSURE  
STATEMENT BY APPLICANT**  
( Not for submission under 37 CFR 1.99)

Application Number	90013252
Filing Date	2014-05-22
First Named Inventor	HARVEY SLEPIAN
Art Unit	3992
Examiner Name	England, David E.
Attorney Docket Number	

<u>80</u>	CLEMENT B. SOMUAH, ANDREW F. BURKE, BIMAL K. BOSE, ROBERT D. KING, and MICHAEL A. POCOBELLO, A Microcomputer-Controlled Powertrain for a Hybrid Vehicle, May 1983, pp. 126-131, IEEE Transactions On Industrial Electronics.	<input type="checkbox"/>
<u>81</u>	7 Series Owner's Handbook, Manual, 1993, pp. 2-132, BMW AG, Germany.	<input type="checkbox"/>
<u>82</u>	COMSIS CORPORATION, Preliminary Human Factors Guidelines For Crash Avoidance Warning Devices, Report, January 1996, pp. 1-175, U.S. Department of Transportation National Highway Traffic Safety Administration.	<input type="checkbox"/>
<u>83</u>	ALFRED HOESS, Realisation of an Intelligent Cruise Control System Utilizing Classification of Distance, Relative Speed and Vehicle Speed Information, Article.	<input type="checkbox"/>
<u>84</u>	Road Vehicles - Adaptive Cruise Control Systems - Performance Requirements and Test Procedures, Draft International Standard, 1999-07-19, pp. 1-32, ISO.	<input type="checkbox"/>
<u>85</u>	Electronic Data Interchange Between Microcomputer Systems in Heavy-Duty Vehicle Applications, Report, January 2013, pp. 1-268, Society of Automotive Engineers.	<input type="checkbox"/>
<u>86</u>	Serial Data Communications Between Microcomputer Systems in Heavy-Duty Vehicle Applications, Report, December 2010, pp. 1-14, Society of Automotive Engineers.	<input type="checkbox"/>
<u>87</u>	Powertrain Control Interface for Electronic Controls Used in Medium- and Heavy-Duty Diesel On-Highway Vehicle Applications, Report, August 2011, pp. 1-18, Society of Automotive Engineers.	<input type="checkbox"/>
<u>88</u>	Serial Control and Communications Heavy Duty Vehicle Network - Top Level Document, Report, August 2013, pp. 1-29, Society of Automotive Engineers.	<input type="checkbox"/>
<u>89</u>	P. FANCHER, Z. BAREKET, S. BOGARD, C. MACADAM, and R. ERVIN, Tests Characterizing Performance of an Adaptive Cruise Control System, Technical Paper, 1997-02-24, pp. 1-12, Society of Automotive Engineers Technical Paper Series.	<input type="checkbox"/>
<u>90</u>	The Computerized Family Car will be Commonplace in Europe Before the End of the Decade, Journal, September 1982, pp. 1-8.	<input type="checkbox"/>

ALL REFERENCES CONSIDERED EXCEPT WHERE LINED THROUGH. /DE/

Receipt date: 08/22/2014

<b>INFORMATION DISCLOSURE STATEMENT BY APPLICANT</b> ( Not for submission under 37 CFR 1.99)	Application Number	90013252
	Filing Date	2014-05-22
	First Named Inventor	HARVEY SLEPIAN
	Art Unit	3992
	Examiner Name	England, David E.
	Attorney Docket Number	

91	PAUL GREEN, What Do Drivers Say They Use Speedometers and Tachometers For?, Report, October 1983, pp. 1-40, University of Michigan Transportation Research Institute.	<input type="checkbox"/>
----	---	--------------------------

If you wish to add additional non-patent literature document citation information please click the Add button

**EXAMINER SIGNATURE**

Examiner Signature	/David England/	Date Considered	10/14/2014
--------------------	-----------------	-----------------	------------

\*EXAMINER: Initial if reference considered, whether or not citation is in conformance with MPEP 609. Draw line through a citation if not in conformance and not considered. Include copy of this form with next communication to applicant.

<sup>1</sup> See Kind Codes of USPTO Patent Documents at [www.USPTO.GOV](http://www.USPTO.GOV) or MPEP 901.04. <sup>2</sup> Enter office that issued the document, by the two-letter code (WIPO Standard ST.3). <sup>3</sup> For Japanese patent documents, the indication of the year of the reign of the Emperor must precede the serial number of the patent document. <sup>4</sup> Kind of document by the appropriate symbols as indicated on the document under WIPO Standard ST.16 if possible. <sup>5</sup> Applicant is to place a check mark here if English language translation is attached.

ALL REFERENCES CONSIDERED EXCEPT WHERE LINED THROUGH. /DE/

Receipt date: 08/22/2014

**INFORMATION DISCLOSURE  
STATEMENT BY APPLICANT**  
( Not for submission under 37 CFR 1.99)

Application Number	90013252
Filing Date	2014-05-22
First Named Inventor	HARVEY SLEPIAN
Art Unit	3992
Examiner Name	England, David E.
Attorney Docket Number	

**CERTIFICATION STATEMENT**

Please see 37 CFR 1.97 and 1.98 to make the appropriate selection(s):

That each item of information contained in the information disclosure statement was first cited in any communication from a foreign patent office in a counterpart foreign application not more than three months prior to the filing of the information disclosure statement. See 37 CFR 1.97(e)(1).

**OR**

That no item of information contained in the information disclosure statement was cited in a communication from a foreign patent office in a counterpart foreign application, and, to the knowledge of the person signing the certification after making reasonable inquiry, no item of information contained in the information disclosure statement was known to any individual designated in 37 CFR 1.56(c) more than three months prior to the filing of the information disclosure statement. See 37 CFR 1.97(e)(2).

See attached certification statement.

The fee set forth in 37 CFR 1.17 (p) has been submitted herewith.

A certification statement is not submitted herewith.

**SIGNATURE**

A signature of the applicant or representative is required in accordance with CFR 1.33, 10.18. Please see CFR 1.4(d) for the form of the signature.

Signature	/Patrick D. Richards/	Date (YYYY-MM-DD)	08/22/14
Name/Print	Patrick Richards	Registration Number	48905

This collection of information is required by 37 CFR 1.97 and 1.98. The information is required to obtain or retain a benefit by the public which is to file (and by the USPTO to process) an application. Confidentiality is governed by 35 U.S.C. 122 and 37 CFR 1.14. This collection is estimated to take 1 hour to complete, including gathering, preparing and submitting the completed application form to the USPTO. Time will vary depending upon the individual case. Any comments on the amount of time you require to complete this form and/or suggestions for reducing this burden, should be sent to the Chief Information Officer, U.S. Patent and Trademark Office, U.S. Department of Commerce, P.O. Box 1450, Alexandria, VA 22313-1450. **DO NOT SEND FEES OR COMPLETED FORMS TO THIS ADDRESS. SEND TO: Commissioner for Patents, P.O. Box 1450, Alexandria, VA 22313-1450.**

Docket No. 1089-001

**PATENT**

**IN THE UNITED STATES PATENT AND TRADEMARK OFFICE**

**Appl. No.** : 90/013,252                      **Confirmation No.** : 9999  
**Patent No.** : 5,954,781  
**Filed** : May 22, 2014  
**Art Unit.** : 3992  
**Examiner** : David E. England  
**Customer No.:** 88360

Commissioner for Patents  
P.O. Box 1450  
Alexandria, VA 22313-1450

**CERTIFICATE OF SERVICE**

I hereby certify that a copy of the IDS is being served on September 30, 2014, by  
Federal Express on the third party requester at the following address:

Clifford A. Ulrich  
Kenyon & Kenyon LLP  
One Broadway  
New York, NY 10004

RICHARDS PATENT LAW PC



Patrick D. Richards  
Registration. No. 48,905

Richards Patent Law P.C.  
233 S. Wacker Dr., 84<sup>th</sup> Floor  
Chicago, IL 60606  
Phone: (312) 283-8555  
**Date: September 30, 2014**

## Electronic Acknowledgement Receipt

<b>EFS ID:</b>	20327011
<b>Application Number:</b>	90013252
<b>International Application Number:</b>	
<b>Confirmation Number:</b>	9999
<b>Title of Invention:</b>	Method and Apparatus for Optimizing Vehicle Operation
<b>First Named Inventor/Applicant Name:</b>	5,954,781
<b>Customer Number:</b>	88360
<b>Filer:</b>	Patrick Duffy Richards
<b>Filer Authorized By:</b>	
<b>Attorney Docket Number:</b>	
<b>Receipt Date:</b>	03-OCT-2014
<b>Filing Date:</b>	22-MAY-2014
<b>Time Stamp:</b>	16:35:24
<b>Application Type:</b>	Reexam (Third Party)

### Payment information:

Submitted with Payment	no
------------------------	----

### File Listing:

Document Number	Document Description	File Name	File Size(Bytes)/ Message Digest	Multi Part /.zip	Pages (if appl.)
1	Reexam Certificate of Service	1089CertificateofService.pdf	75811 <small>3454caaae9779d4d6f170e8fca31d12d9ec0668e</small>	no	1

### Warnings:

### Information:

This Acknowledgement Receipt evidences receipt on the noted date by the USPTO of the indicated documents, characterized by the applicant, and including page counts, where applicable. It serves as evidence of receipt similar to a Post Card, as described in MPEP 503.

**New Applications Under 35 U.S.C. 111**

If a new application is being filed and the application includes the necessary components for a filing date (see 37 CFR 1.53(b)-(d) and MPEP 506), a Filing Receipt (37 CFR 1.54) will be issued in due course and the date shown on this Acknowledgement Receipt will establish the filing date of the application.

**National Stage of an International Application under 35 U.S.C. 371**

If a timely submission to enter the national stage of an international application is compliant with the conditions of 35 U.S.C. 371 and other applicable requirements a Form PCT/DO/EO/903 indicating acceptance of the application as a national stage submission under 35 U.S.C. 371 will be issued in addition to the Filing Receipt, in due course.

**New International Application Filed with the USPTO as a Receiving Office**

If a new international application is being filed and the international application includes the necessary components for an international filing date (see PCT Article 11 and MPEP 1810), a Notification of the International Application Number and of the International Filing Date (Form PCT/RO/105) will be issued in due course, subject to prescriptions concerning national security, and the date shown on this Acknowledgement Receipt will establish the international filing date of the application.

<b>INFORMATION DISCLOSURE STATEMENT BY APPLICANT ( Not for submission under 37 CFR 1.99)</b>	Application Number		90013252
	Filing Date		2014-05-22
	First Named Inventor	HARVEY SLEPIAN	
	Art Unit	3992	
	Examiner Name	England, David E.	
	Attorney Docket Number	1089-001	

U.S. PATENTS						Remove
Examiner Initial*	Cite No	Patent Number	Kind Code <sup>1</sup>	Issue Date	Name of Patentee or Applicant of cited Document	Pages, Columns, Lines where Relevant Passages or Relevant Figures Appear
	1	5954781		1999-21-09	Velocity Patent LLC.	
	2	5416698		1995-16-05	Ronald A. Hutchison	
	3	5498195		1996-12-03	Gregory R. White	
	4	3835819		1974-09-17	Anderson	
	5	3892483		1975-07-01	Säufferer	
	6	3925753		1975-12-09	Auman	
	7	4061055		1997-12-06	lizuka	
	8	4075892		1978-02-28	Burchkhardt	



<b>INFORMATION DISCLOSURE STATEMENT BY APPLICANT</b> ( Not for submission under 37 CFR 1.99)	Application Number	90013252
	Filing Date	2014-05-22
	First Named Inventor	HARVEY SLEPIAN
	Art Unit	3992
	Examiner Name	England, David E.
	Attorney Docket Number	1089-001

9	4097864		1978-06-27	Endo	
10	4208925		1980-06-24	Miller	
11	4221126		1980-09-09	Cordiano	
12	4250485		1981-02-10	Mostert	
13	4255789		1981-03-10	Hartford	
14	4271402		1981-06-02	Kastura	
15	4280358		1981-07-28	Henderson	
16	4286683		1981-09-01	Zeigner	
17	4398174		1983-08-09	Smith, Jr.	
18	4411174		1983-10-25	Yokoi	
19	4438423		1984-03-20	Stier	

<b>INFORMATION DISCLOSURE STATEMENT BY APPLICANT</b> ( Not for submission under 37 CFR 1.99)	Application Number	90013252
	Filing Date	2014-05-22
	First Named Inventor	HARVEY SLEPIAN
	Art Unit	3992
	Examiner Name	England, David E.
	Attorney Docket Number	1089-001

	20	4439158		1984-03-27	Weber	
	21	4439833		1984-03-27	Yamaguchi	
	22	4459670		1984-07-10	Yamaguchi	
	23	4492112		1995-01-08	Igarashi	
	24	4542460		1985-09-17	Weber	
	25	4546747		1985-10-15	Kobayashi	
	26	4550596		1985-11-05	Ueda	
	27	4555691		1985-11-26	Hosaka	
	28	4559599		1985-12-17	Habu	
	29	4570226		1986-02-11	Aussedat	
	30	4604700		1986-08-05	Igarashi	

<b>INFORMATION DISCLOSURE STATEMENT BY APPLICANT</b> ( Not for submission under 37 CFR 1.99)	Application Number	90013252
	Filing Date	2014-05-22
	First Named Inventor	HARVEY SLEPIAN
	Art Unit	3992
	Examiner Name	England, David E.
	Attorney Docket Number	1089-001

	31	4622637		1986-11-11	Tomita	
	32	4631515		1986-12-23	Blee	
	33	4632543		1986-12-30	Endo	
	34	4677556		1987-06-30	Habu	
	35	4683455		1987-07-28	Kido	
	36	4701852		1987-10-20	Ulveland	
	37	4703304		1987-10-27	Muguruma	
	38	4712452		1987-12-15	Hibino	
	39	4723215		1988-02-02	Hibino	
	40	4731727		1988-03-15	Rauch	
	41	4748955		1988-06-07	Yonekawa	

<b>INFORMATION DISCLOSURE STATEMENT BY APPLICANT</b> ( Not for submission under 37 CFR 1.99)	Application Number	90013252
	Filing Date	2014-05-22
	First Named Inventor	HARVEY SLEPIAN
	Art Unit	3992
	Examiner Name	England, David E.
	Attorney Docket Number	1089-001

	42	4752883		1988-06-21	Asakura	
	43	4800859		1989-01-31	Sagisaka	
	44	4853673		1989-08-01	Kido	
	45	4868756		1989-09-19	Kawanabe	
	46	4885690		1989-12-05	Schimmel	
	47	4901701		1990-02-20	Chasteen	
	48	4945870		1990-08-07	Richeson	
	49	5014200		1991-05-07	Chundrik	
	50	5017916		1991-05-21	Londt	
	51	5053979		1991-10-01	Etoh	
	52	5113721		1992-05-19	Polly	

<b>INFORMATION DISCLOSURE STATEMENT BY APPLICANT</b> ( Not for submission under 37 CFR 1.99)	Application Number	90013252
	Filing Date	2014-05-22
	First Named Inventor	HARVEY SLEPIAN
	Art Unit	3992
	Examiner Name	England, David E.
	Attorney Docket Number	1089-001

	53	5123397		1992-06-23	Richeson	
	54	5155682		1992-10-13	Ninoyu	
	55	5157991		1992-10-27	Sumimoto	
	56	5165497		1992-11-24	Chi	
	57	5187935		1993-02-23	Akiyama	
	58	5209206		1993-05-11	Danno	
	59	5227784		1993-07-13	Masamori	
	60	5234071		1993-08-10	Kajiwara	
	61	5261382		1993-11-16	Nikolai	
	62	5278764		1994-01-11	lizuka	
	63	5302956		1994-04-12	Asbury	

<b>INFORMATION DISCLOSURE STATEMENT BY APPLICANT</b> ( Not for submission under 37 CFR 1.99)	Application Number	90013252
	Filing Date	2014-05-22
	First Named Inventor	HARVEY SLEPIAN
	Art Unit	3992
	Examiner Name	England, David E.
	Attorney Docket Number	1089-001

	64	5357438		1994-10-18	Davidian	
	65	5396426		1995-03-07	Hibino	
	66	5410304		1995-04-25	Hahn	
	67	5420792		1995-05-30	Butsuen	
	68	5436835		1995-07-25	Emry	
	69	5443594		1995-08-22	Takada	
	70	5477452		1995-12-19	Milunas	
	71	5483939		1996-01-16	Kamura	
	72	5483945		1996-01-16	Kobayashi	
	73	5521579		1996-05-28	Bernhard	
	74	5530651		1996-06-25	Uemura	

<b>INFORMATION DISCLOSURE STATEMENT BY APPLICANT</b> ( Not for submission under 37 CFR 1.99)	Application Number		90013252	
	Filing Date		2014-05-22	
	First Named Inventor	HARVEY SLEPIAN		
	Art Unit		3992	
	Examiner Name	England, David E.		
	Attorney Docket Number		1089-001	

	75	5564999		1996-10-15	Bellinger	
	76	5572428		1996-11-05	Ishida	
	77	5574644		1996-11-12	Butsuen	
	78	5587908		1996-12-24	Kajiwara	
	79	5647647		1997-07-15	Kato	
	80	5659304		1997-08-19	Chakraborty	
	81	5708584		1998-01-13	Doi	
	82	5710565		1998-01-20	Shirai	
	83	5745870		1998-04-28	Yamamoto	
	84	5754968		1998-05-19	Hedstrom	
	85	5778856		1998-07-14	Okada	

<b>INFORMATION DISCLOSURE STATEMENT BY APPLICANT</b> ( Not for submission under 37 CFR 1.99)	Application Number		90013252	
	Filing Date		2014-05-22	
	First Named Inventor		HARVEY SLEPIAN	
	Art Unit		3992	
	Examiner Name		England, David E.	
	Attorney Docket Number		1089-001	

	86	5781103		1998-07-14	Gilling	
	87	5805103		1998-09-08	Doi	
	88	5845492		1998-12-08	Isobe et al.	
	89	5864285		1999-01-26	Wieder	
	90	5865265		1999-02-02	Matsumoto	
	91	5929784		1999-07-27	Kawaziri	
	92	5934399		1999-08-10	liboshi	
	93	5952939		1999-09-14	Nakazawa	
	94	6031484		2000-02-29	Bullinger	
	95	6058348		2000-05-02	Ohyama	
	96	6293738		2001-05-29	Wanielik	



<b>INFORMATION DISCLOSURE STATEMENT BY APPLICANT</b> ( Not for submission under 37 CFR 1.99)	Application Number		90013252	
	Filing Date		2014-05-22	
	First Named Inventor		HARVEY SLEPIAN	
	Art Unit		3992	
	Examiner Name		England, David E.	
	Attorney Docket Number		1089-001	

	97	5067372		1991-11-26	Suzuki	
	98	4719820		1988-01-19	Hibino et al.	
	99	6497297		2002-12-24	Ebert et al.	
	100	5226351		1993-07-13	Matsuoka et al.	
	101	6345227		2002-02-06	Egawa et al.	
	102	4132284		1979-01-02	Tomecek	
	103	5460582		1995-10-24	Palansky et al.	
	104	3671081		1972-06-20	Jania et al.	
	105	6178370		2001-01-23	Zierolf	
	106	5268692		1993-12-07	Grosch et al.	
	107	5305663		1994-04-26	Leonard et al.	

<b>INFORMATION DISCLOSURE STATEMENT BY APPLICANT</b> ( Not for submission under 37 CFR 1.99)	Application Number		90013252	
	Filing Date		2014-05-22	
	First Named Inventor	HARVEY SLEPIAN		
	Art Unit	3992		
	Examiner Name	England, David E.		
	Attorney Docket Number	1089-001		

	108	6294990		2001-09-25	Knoll et al.	
	109	5644490		1997-07-01	Weber	
	110	6070682		2000-06-06	Isogai et al.	
	111	4308536		1981-12-29	Sims, Jr. et al.	
	112	5775451		1998-07-07	Hull et al.	
	113	5949346		1999-09-07	Suzuki et al.	
	114	5341144		1994-08-23	Stove	
	115	5544056		1996-08-06	Seireg et al.	
	116	4916450		1990-04-10	Davis	
	117	5754123		1998-05-19	Nashif et al.	
	118	5808374		1998-09-15	Miller et al.	

<b>INFORMATION DISCLOSURE STATEMENT BY APPLICANT</b> ( Not for submission under 37 CFR 1.99)	Application Number	90013252
	Filing Date	2014-05-22
	First Named Inventor	HARVEY SLEPIAN
	Art Unit	3992
	Examiner Name	England, David E.
	Attorney Docket Number	1089-001

	119	6233515		2001-05-15	Engelman et al.	
	120	4463427		1984-07-31	Bonnetain et al.	
	121	3921749		1975-11-25	Kawada	
	122	6125320		2000-09-26	Hellmann et al.	
	123	4872051		1989-10-03	Dye	
	124	5673987		1997-10-07	Futschik et al.	
	125	5777563		1998-07-07	Minissale et al.	
	126	4796716		1989-01-10	Masuda	
	127	5074144		1991-12-24	Krofchalk et al.	
	128	2804160		1957-08-27	Rashid	
	129	5173859		1992-12-22	Deering	

<b>INFORMATION DISCLOSURE STATEMENT BY APPLICANT</b> ( Not for submission under 37 CFR 1.99)	Application Number	90013252
	Filing Date	2014-05-22
	First Named Inventor	HARVEY SLEPIAN
	Art Unit	3992
	Examiner Name	England, David E.
	Attorney Docket Number	1089-001

If you wish to add additional U.S. Patent citation information please click the Add button.							Add
<b>U.S.PATENT APPLICATION PUBLICATIONS</b>							Remove
Examiner Initial*	Cite No	Publication Number	Kind Code <sup>1</sup>	Publication Date	Name of Patentee or Applicant of cited Document	Pages,Columns,Lines where Relevant Passages or Relevant Figures Appear	
	1	20020000122	A1	2002-01-03	Reuter		

If you wish to add additional U.S. Published Application citation information please click the Add button.								Add
<b>FOREIGN PATENT DOCUMENTS</b>								Remove
Examiner Initial*	Cite No	Foreign Document Number <sup>3</sup>	Country Code <sup>2</sup> j	Kind Code <sup>4</sup>	Publication Date	Name of Patentee or Applicant of cited Document	Pages,Columns,Lines where Relevant Passages or Relevant Figures Appear	T <sup>5</sup>
	1	JP H05-248894	JP		1993-09-24	Okamoto Yoshiyuki		<input checked="" type="checkbox"/>
	2	H06-052499	JP		1994-02-25	Yamamura Toshihiro		<input checked="" type="checkbox"/>
	3	H06-227337	JP		1994-08-16	Imai Yasuo		<input checked="" type="checkbox"/>
	4	H06-242234	JP		1994-09-02	Maeda Kozo and Ueno Yasushi		<input checked="" type="checkbox"/>
	5	H06-247247	JP		1994-09-06	Imai Yasuo		<input checked="" type="checkbox"/>
	6	H06-298021	JP		1994-10-25	Sasaki Kazuya, Hashimoto Yoshiyuki, Imai Yasuo		<input checked="" type="checkbox"/>

<b>INFORMATION DISCLOSURE STATEMENT BY APPLICANT</b> ( Not for submission under 37 CFR 1.99)	Application Number	90013252
	Filing Date	2014-05-22
	First Named Inventor	HARVEY SLEPIAN
	Art Unit	3992
	Examiner Name	England, David E.
	Attorney Docket Number	1089-001

7	H07-075218	JP		1995-03-17	Takimoto Tadao and Shirai Tetsuyuki	<input checked="" type="checkbox"/>
8	H07-322415	JP		1995-12-08	Suzuki Akira	<input checked="" type="checkbox"/>
9	H08-005436	JP		1996-01-12	Fujieda Terumitsu	<input checked="" type="checkbox"/>
10	H08-212499	JP		1996-08-20	Izawa Kazuyuki	<input checked="" type="checkbox"/>
11	EP Appln. 0419399	EP		1991-03-27	Ariav	<input type="checkbox"/>
12	EP Appln. 0544468	EP		1993-06-02	Faibish	<input type="checkbox"/>
13	EP Appln. 0637525	EP		1995-02-08	Waffler	<input type="checkbox"/>
14	EP 0392953	EP		1996-08-28	Tresse	<input type="checkbox"/>
15	EP 0404353	EP		1994-08-03	Genise	<input type="checkbox"/>
16	EP 0549909	EP		1996-08-28	Kajiwata	<input type="checkbox"/>
17	DE Appln. 2164465	DE		1973-06-28	Borchardt	<input type="checkbox"/>

**INFORMATION DISCLOSURE  
STATEMENT BY APPLICANT**  
( Not for submission under 37 CFR 1.99)

Application Number		90013252
Filing Date		2014-05-22
First Named Inventor	HARVEY SLEPIAN	
Art Unit	3992	
Examiner Name	England, David E.	
Attorney Docket Number	1089-001	

18	DE Appln. 2241427	DE		1974-03-21	Bernhard		<input type="checkbox"/>
19	DE Appln. 2926070	DE		1981-01-15	Fiala		<input type="checkbox"/>
20	DE Appln. 3115096	DE		1983-01-27	Dipl		<input type="checkbox"/>
21	DE Appln. 3642196	DE		1988-06-23	Langer		<input type="checkbox"/>
22	DE Appln. 4117534	DE		1992-03-12	Krenzin		<input type="checkbox"/>
23	DE Appln. 3249455	DE		1984-12-13	Meyer		<input type="checkbox"/>
24	DE Appln. 3912359	DE		1990-10-25	Lexen		<input type="checkbox"/>
25	DE Appln. 4003057	DE		1991-08-08	Huder		<input type="checkbox"/>
26	DE Appln. 4309606	DE		1994-09-29	Weishaupt		<input type="checkbox"/>
27	DE Appln. 4437365	DE		1996-05-02	Butscher		<input type="checkbox"/>
28	DE Appln. 4437678	DE		1996-05-02	Adomat		<input type="checkbox"/>

<b>INFORMATION DISCLOSURE STATEMENT BY APPLICANT</b> ( Not for submission under 37 CFR 1.99)	Application Number	90013252
	Filing Date	2014-05-22
	First Named Inventor	HARVEY SLEPIAN
	Art Unit	3992
	Examiner Name	England, David E.
	Attorney Docket Number	1089-001

	29	DE 3325714	DE		1985-01-31	Lauer		<input type="checkbox"/>
	30	GB Appln. 2173331	GB		1986-10-08	Ritchie		<input type="checkbox"/>
	31	GB Appln. 2265062	GB		1993-09-15	Codd		<input type="checkbox"/>
	32	GB Appln. 2291244	GB		1996-01-17	Tonkin		<input type="checkbox"/>
	33	GB Appln. 2298045	GB		1996-08-21	Mulhall		<input type="checkbox"/>
	34	JP 59109442	JP		1984-06-25	Tatsuno		<input type="checkbox"/>
	35	JP 59188582	JP		1984-10-25	Todome		<input type="checkbox"/>
	36	JP H04-213800	JP		1992-08-04	Hirano		<input type="checkbox"/>
	37	JP H04-232130	JP		1992-08-20	Hirano		<input type="checkbox"/>
	38	JP H04-242895	JP		1992-08-31	Umemoto		<input type="checkbox"/>
	39	JP H04-242896	JP		1992-08-31	Hirano		<input type="checkbox"/>

<b>INFORMATION DISCLOSURE STATEMENT BY APPLICANT</b> ( Not for submission under 37 CFR 1.99)	Application Number		90013252	
	Filing Date		2014-05-22	
	First Named Inventor	HARVEY SLEPIAN		
	Art Unit	3992		
	Examiner Name	England, David E.		
	Attorney Docket Number	1089-001		

	40	JP H04-242900	JP		1992-08-31	Nakamura		<input type="checkbox"/>
	41	WO 90/010210	WO		1990-09-07	Dickey		<input type="checkbox"/>
	42	WO 91/007672	WO		1991-05-30	Montague		<input type="checkbox"/>
	43	WO 92/021116	WO		1992-11-26	Needham		<input type="checkbox"/>
	44	WO 96/002853	WO		1996-02-01	Tonkin		<input type="checkbox"/>
	45	WO 96/014591	WO		1996-05-17	Rashid		<input type="checkbox"/>
	46	WO 96/020336	WO		1996-07-04	Murakami		<input type="checkbox"/>
	47	GB Appln. 2265341	GB		1993-09-22	Nocker et al.		<input type="checkbox"/>
	48	DE 27 48 227 A1	DE		1977-10-27	Weickmann et al.		<input type="checkbox"/>
	49	WO 00/21773	WO		2000-04-20	Ebert et al.		<input type="checkbox"/>
	50	GB Appln. 2135387	GB		1984-08-30	Stelter et al.		<input type="checkbox"/>



<b>INFORMATION DISCLOSURE STATEMENT BY APPLICANT</b> ( Not for submission under 37 CFR 1.99)	Application Number	90013252
	Filing Date	2014-05-22
	First Named Inventor	HARVEY SLEPIAN
	Art Unit	3992
	Examiner Name	England, David E.
	Attorney Docket Number	1089-001

If you wish to add additional Foreign Patent Document citation information please click the Add button Add

<b>NON-PATENT LITERATURE DOCUMENTS</b>		Remove
Examiner Initials*	Cite No	T <sup>5</sup>
	1	Include name of the author (in CAPITAL LETTERS), title of the article (when appropriate), title of the item (book, magazine, journal, serial, symposium, catalog, etc), date, pages(s), volume-issue number(s), publisher, city and/or country where published.
	1	BMW OF NORTH AMERICA, LLC & BMW MANUFACTURING CO., LLC, Case No. 13-CV-08416 Defendants' Local Patent Rule 2.3 Disclosures, BMW's Invalidity and Non-Infringement Contentions, U.S. District Court for the Northern District of Illinois Eastern Division, Fact Discovery, 2014-04-11, Chicago, Illinois.
	2	CHRYSLER GROUP LLC, Case No. 13-CV-08419 Defendant's Local Patent Rule 2.3 Disclosures, Chrysler's Invalidity and Non-Infringement Contentions, U.S. District Court for the Northern District of Illinois Eastern Division, Fact Discovery, 2014-04-11, Chicago, Illinois.
	3	JAGUAR LAND ROVER NORTH AMERICA, LLC, Case No. 13-CV-08421 Defendant's Local Patent Rule 2.3 Disclosures, Jaguar Land Rover's Invalidity and Non-Infringement Contentions, U.S. District Court for the Northern District of Illinois Eastern Division, Fact Discovery, 2014-04-11, Chicago, Illinois.
	4	MERCEDES-BENZ USA, LLC & MERCEDES-BENZ U.S. INTERNATIONAL INC., Case No. 13-CV-08413 Defendants' Local Patent Rule 2.3 Disclosures, Mercedes' Invalidity and Non-Infringement Contentions, U.S. District Court for the Northern District of Illinois Eastern Division, Fact Discovery, 2014-04-11, Chicago, Illinois.
	5	VELOCITY PATENT LLC, Case No. 13-CV-08416 Plaintiff's Local Patent Rule 2.5 Disclosures, Velocity's Initial Response to BMW's Invalidity Contentions, U.S. District Court for the Northern District of Illinois Eastern Division, Fact Discovery, 2014-05-12, Chicago, Illinois.
	6	VELOCITY PATENT LLC, Case No. 13-CV-08419 Plaintiff's Local Patent Rule 2.5 Disclosures, Velocity's Initial Response to Chrysler's Invalidity Contentions, U.S. District Court for the Northern District of Illinois Eastern Division, Fact Discovery, 2014-05-12, Chicago, Illinois.
	7	VELOCITY PATENT LLC, Case No. 13-CV-08419, Plaintiff's Local Patent Rule 2.5 Disclosures, Velocity's Initial Response to Jaguar Land Rover's Invalidity Contentions, U.S. District Court for the Northern District of Illinois Eastern Division, Fact Discovery, 2014-05-12, Chicago, Illinois.
	8	VELOCITY PATENT LLC, Case No. 13-CV-08413 Plaintiff's Local Patent Rule 2.5 Disclosures, Velocity's Initial Response to Mercedes' Invalidity Contentions, U.S. District Court for the Northern District of Illinois Eastern Division, Fact Discovery, 2014-05-12, Chicago, Illinois.
	9	AUDI OF AMERICA, INC., Case No. 13-CV-08418 Defedant's Local Patent Rule 2.3 Disclosures, Audi's Invalidity and Non-Infringement Contentions, U.S. District Court for the Northern District of Illinois Eastern Division, Fact Discovery, 2014-05-13, Chicago, Illinois.

<b>INFORMATION DISCLOSURE STATEMENT BY APPLICANT ( Not for submission under 37 CFR 1.99)</b>	Application Number		90013252
	Filing Date		2014-05-22
	First Named Inventor	HARVEY SLEPIAN	
	Art Unit	3992	
	Examiner Name	England, David E.	
	Attorney Docket Number	1089-001	

10	VELOCITY PATENT LLC, Case No. 13-CV-08418 Plaintiff's Local Patent Rule 2.5 Disclosures, Velocity's Initial Response to Audi's Invalidity Contentions, U.S. District Court for the Northern District of Illinois Eastern District, Fact Discovery, 2014-06-10, Chicago, Illinois.	<input type="checkbox"/>
11	VELOCITY PATENT LLC, Velocity's Response to Defendants' Common Interrogatories, U.S. District Court for the Northern District of Illinois Eastern Division, Fact Discovery, 2014-03-17, Chicago, Illinois.	<input type="checkbox"/>
12	VELOCITY PATENT LLC, Case No. 13-CV-08418 Velocity's Response to Audi's First Set of Interrogatories, U.S. District Court for the Northern District of Illinois Eastern Division, Fact Discovery, 2014-05-01, Chicago, Illinois.	<input type="checkbox"/>
13	AUDI OF AMERICA, INC., Case No. 13-CV-08418 Defendant's Objections and Responses to Velocity's First Set of Requests For Production (Nos. 1-47), U.S. District Court for the Northern District of Illinois Eastern Division, Fact Discovery, 2014-04-03, Chicago, Illinois.	<input type="checkbox"/>
14	AUDI OF AMERICA, INC., Defendant's Objections and Responses to Velocity's First Set of Interrogatories (Nos. 1-4), U.S. District Court for the Northern District of Illinois Eastern Division, Fact Discovery, 2014-04-03, Chicago, Illinois.	<input type="checkbox"/>
15	BMW OF NORTH AMERICA, LLC & BMW MANUFACTURING CO., LLC, Case No. 13-CV-08416 BMW's Objections and Responses to Velocity's First Set of Requests For Production (Nos. 1-47), U.S. District Court for the Northern District of Illinois Eastern Division, Fact Discovery, 2014-03-17, Chicago, Illinois.	<input type="checkbox"/>
16	BMW OF NORTH AMERICA, LLC & BMW MANUFACTURING CO., LLC, Case No. 13-CV-08416 BMW's Objections and Responses to Velocity's First Set Of Interrogatories (Nos. 1-3), U.S. District Court for the Northern District of Illinois Eastern Division, Fact Discovery, 2014-03-17, Chicago, Illinois.	<input type="checkbox"/>
17	BMW OF NORTH AMERICA, LLC & BMW MANUFACTURING CO., LLC, Case No. 13-CV-08416 BMW's Objections and Responses to Velocity's Second Set of Interrogatories (No. 4), U.S. District Court for the Northern District of Illinois Eastern Division, Fact Discovery, 2014-04-07, Chicago, Illinois.	<input type="checkbox"/>
18	BMW OF NORTH AMERICA, LLC & BMW MANUFACTURING CO., LLC, Case No. 13-CV-08416 BMW's First Supplemental Objections and Responses to Velocity's Second Set of Interrogatories (No. 4), U.S. District Court for the Northern District of Illinois Eastern Division, Fact Discovery, 2014-05-09, Chicago, Illinois.	<input type="checkbox"/>
19	CHRYSLER GROUP LLC, Case No. 13-CV-08419 Chrysler's Objections and Responses to Velocity's First Set Of Interrogatories (Nos. 1-3), U.S. District Court for the Northern District of Illinois Eastern Division, Fact Discovery, 2014-03-17, Chicago, Illinois.	<input type="checkbox"/>
20	CHRYSLER GROUP LLC, Case No. 13-CV-08419 Chrysler's Objections and Responses to Velocity's First Set of Requests For Production (Nos. 1-47), U.S. District Court for the Northern District of Illinois Eastern Division, Fact Discovery, 2014-03-17, Chicago, Illinois.	<input type="checkbox"/>

<b>INFORMATION DISCLOSURE STATEMENT BY APPLICANT</b> ( Not for submission under 37 CFR 1.99)	Application Number	90013252
	Filing Date	2014-05-22
	First Named Inventor	HARVEY SLEPIAN
	Art Unit	3992
	Examiner Name	England, David E.
	Attorney Docket Number	1089-001

21	CHRYSLER GROUP LLC, Case No. 13-CV-08419 Chrysler's Objections and Responses to Velocity's Second Set of Interrogatories (No. 4), Case Discovery, 2014-04-07, Chicago, Illinois.	<input type="checkbox"/>
22	CHRYSLER GROUP LLC, Case No. 13-CV-08419 Chrysler's First Supplemental Objections and Responses to Velocity's First Set of Interrogatories (No. 1), Case Discovery, 2014-06-11, Chicago, Illinois.	<input type="checkbox"/>
23	CHRYSLER GROUP LLC, Case No. 13-CV-08419 Chrysler's First Supplemental Objections and Responses to Velocity's Second Set of Interrogatories (No. 4), Case Discovery, 2014-06-11, Chicago, Illinois.	<input type="checkbox"/>
24	JAGUAR LAND ROVER NORTH AMERICA, LLC, Case No. 13-CV-08419, Jaguar Land Rover's Objections and Responses to Velocity's First Set Of Interrogatories (Nos. 1-3), Case Discovery, 2014-03-17, Chicago, Illinois.	<input type="checkbox"/>
25	JAGUAR LAND ROVER NORTH AMERICA, LLC, Case No. 13-CV-08419, Jaguar Land Rover's Objections and Responses to Velocity's First Set of Requests For Production (Nos. 1-47), Case Discovery, 2014-03-17, Chicago, Illinois.	<input type="checkbox"/>
26	JAGUAR LAND ROVER NORTH AMERICA, LLC, Case No. 13-CV-08419, Jaguar Land Rover's Objections and Responses to Velocity's Second Set of Interrogatories (No. 4), Case Discovery, 2014-04-07, Chicago, Illinois.	<input type="checkbox"/>
27	JAGUAR LAND ROVER NORTH AMERICA, LLC, Case No. 13-CV-08419 Chrysler's First Supplemental Objections and Responses to Velocity's First Set of Interrogatories (No. 1), Case Discovery, 2014-06-06, Chicago, Illinois.	<input type="checkbox"/>
28	MERCEDES-BENZ USA, LLC, Case No. 13-CV-08413 Mercedes-Benz USA's Objections and Responses to Velocity's First Set Of Interrogatories (Nos. 1-3), Case Discovery, 2014-03-24, Chicago, Illinois.	<input type="checkbox"/>
29	MERCEDES-BENZ U.S. INTERNATIONAL INC., Case No. 13-CV-08413 Mercedes-Benz International's Objections and Responses to Velocity's First Set Of Interrogatories (Nos. 1-3), Case Discovery, 2014-03-24, Chicago, Illinois.	<input type="checkbox"/>
30	MERCEDES-BENZ USA, LLC, Case No. 13-CV-08413 Mercedes-Benz USA's Objections and Responses to Velocity's First Set of Requests For Production (Nos. 1-47), Case Discovery, 2014-03-24, Chicago, Illinois.	<input type="checkbox"/>
31	MERCEDES-BENZ U.S. INTERNATIONAL INC., Case No. 13-CV-08413 Mercedes-Benz International's Objections and Responses to Velocity's First Set of Requests For Production (Nos. 1-47), Case Discovery, 2014-03-24, Chicago, Illinois.	<input type="checkbox"/>

<b>INFORMATION DISCLOSURE STATEMENT BY APPLICANT</b> ( Not for submission under 37 CFR 1.99)	Application Number	90013252
	Filing Date	2014-05-22
	First Named Inventor	HARVEY SLEPIAN
	Art Unit	3992
	Examiner Name	England, David E.
	Attorney Docket Number	1089-001

32	MERCEDES-BENZ USA, LLC, Case No. 13-CV-08413 Mercedes-Benz USA's Objections and Responses to Velocity's Second Set of Interrogatories (No. 4), Case Discovery, 2014-04-14, Chicago, Illinois.	<input type="checkbox"/>
33	MERCEDES-BENZ U.S. INTERNATIONAL INC., Case No. 13-CV-08413 Mercedes-Benz International's Objections and Responses to Velocity's Second Set of Interrogatories (No. 4), Case Discovery, 2014-04-14, Chicago, Illinois.	<input type="checkbox"/>
34	VELOCITY PATENT LLC, Case No. 13-CV-08418 Docket # 1 Complaint For Patent Infringement to Audi of America, Inc. & Audi of America, LLC, U.S. District Court for the Northern District of Illinois Eastern Division, Case Complaint, 2013-11-21, Chicago, Illinois.	<input type="checkbox"/>
35	VELOCITY PATENT LLC, Case No. 13-CV-08418 Docket # 28 First Amended Complaint For Patent Infringement to Audi of America, Inc., U.S. District Court for the Northern District of Illinois Eastern Division, Case Complaint, 2014-01-30, Chicago, Illinois.	<input type="checkbox"/>
36	AUDI OF AMERICA, INC., Case No. 13-CV-08418 Docket # 23 Audi of America, Inc.'s Motion to Dismiss Velocity's Complaint for Failure to State a Claim, U.S. District Court for the Northern District of Illinois Eastern Division, Case Pleading, 2014-01-27, Chicago, Illinois.	<input type="checkbox"/>
37	AUDI OF AMERICA, INC., Case No. 13-CV-08418 Docket # 24 Audi of America, Inc.'s Brief in Support of their Motion to Dismiss Velocity's Complaint for Failure to State a Claim, U.S. District Court for the Northern District of Illinois Eastern Division, Case Pleading, 2014-01-27, Chicago, Illinois.	<input type="checkbox"/>
38	AUDI OF AMERICA, INC., Case No. 13-CV-08418 Docket # 36 Audi of America, Inc.'s Motion to Dismiss Velocity's First Amended Complaint for Failure to State a Claim, U.S. District Court for the Northern District of Illinois Eastern Division, Case Pleading, 2014-02-18, Chicago, Illinois.	<input type="checkbox"/>
39	AUDI OF AMERICA, INC., Case No. 13-CV-08418 Docket # 37 Audi of America, Inc.'s Memorandum in Support of its Motion to Dismiss Velocity's First Amended Complaint for Failure to State a Claim, U.S. District Court for the Northern District of Illinois Eastern Division, Case Pleading, 2014-02-18, Chicago, Illinois.	<input type="checkbox"/>
40	VELOCITY PATENT LLC, Case No. 13-CV-08418 Docket # 45 Velocity Patent LLC's Response to Defendant's Motion to Dismiss, U.S. District Court for the Northern District of Illinois Eastern Division, Case Pleading, 2014-03-19, Chicago, Illinois.	<input type="checkbox"/>
41	AUDI OF AMERICA, INC., Case No. 13-CV-08418 Docket # 47 Audi of America, Inc.'s Reply in Support of Its Motion to Dismiss Velocity's First Amended Complaint for Failure to State a Claim, U.S. District Court for the Northern District of Illinois Eastern Division, Case Pleading, 2014-02-04, Chicago, Illinois.	<input type="checkbox"/>
42	VELOCITY PATENT LLC, Case No. 13-CV-08416 Docket # 1 Complaint for Patent Infringement to BMW of North America, LLC & BMW Manufacturing Co., LLC, U.S. District Court for the Northern District of Illinois Eastern Division, Case Pleading, 2013-11-21, Chicago, Illinois.	<input type="checkbox"/>

<b>INFORMATION DISCLOSURE STATEMENT BY APPLICANT ( Not for submission under 37 CFR 1.99)</b>	Application Number		90013252
	Filing Date		2014-05-22
	First Named Inventor	HARVEY SLEPIAN	
	Art Unit	3992	
	Examiner Name	England, David E.	
	Attorney Docket Number	1089-001	

43	BMW OF NORTH AMERICA, LLC, Case No. 13-CV-08416 Docket # 21 BMW of North America's Answer and Counterclaim to Velocity's Complaint, U.S. District Court for the Northern District of Illinois Eastern Division, Case Pleading, 2014-01-27, Chicago, Illinois.	<input type="checkbox"/>
44	BMW MANUFACTURING CO., LLC, Case No. 13-CV-08416 Docket # 22 BMW Manufacturing's Answer and Counterclaim to Velocity's Complaint, U.S. District Court for the Northern District of Illinois Eastern Division, Case Pleading, 2014-01-27, Chicago, Illinois.	<input type="checkbox"/>
45	VELOCITY PATENT LLC, Case No. 13-CV-08416 Docket # 28 Velocity's Answer to Defendant BMW Manufacturing's Counterclaims, U.S. District Court for the Northern District of Illinois Eastern Division, Case Pleading, 2014-02-18, Chicago, Illinois.	<input type="checkbox"/>
46	VELOCITY PATENT LLC, Case No. 13-CV-08416 Docket # 29 Velocity's Answer to Defendant BMW of North America's Counterclaims, U.S. District Court for the Northern District of Illinois Eastern Division, Case Pleading, 2014-02-18, Chicago, Illinois.	<input type="checkbox"/>
47	VELOCITY PATENT LLC, Case No. 13-CV-08419 Docket # 1 Complaint for Patent Infringement to Chrysler Group LLC, U.S. District Court for the Northern District of Illinois Eastern Division, Case Pleading, 2013-11-21, Chicago, Illinois.	<input type="checkbox"/>
48	CHRYSLER GROUP LLC, Case No. 13-CV-08419 Docket # 24 Chrysler Group LLC's Anser to Velocity's Complaint, U.S. District Court for the Northern District of Illinois Eastern Division, Case Pleading, 2014-01-27, Chicago, Illinois.	<input type="checkbox"/>
49	VELOCITY PATENT LLC, Case No. 13-CV-08421 Docket # 1 Complaint for Patent Infringement to Jaguar Land Rover North America, LLC, U.S. District Court for the Northern District of Illinois Eastern Division, Case Pleading, 2013-11-21, Chicago, Illinois.	<input type="checkbox"/>
50	JAGUAR LAND ROVER NORTH AMERICA, LLC, Case No. 13-CV-08421 Docket #23 Jaguar Land Rover's Answer and Affirmative Defenses to Velocity's Original Complaint, U.S. District Court for the Northern District of Illinois Eastern Division, Case Pleading, 2014-01-27, Chicago, Illinois.	<input type="checkbox"/>

If you wish to add additional non-patent literature document citation information please click the Add button Add

**EXAMINER SIGNATURE**

Examiner Signature		Date Considered	
--------------------	--	-----------------	--

\*EXAMINER: Initial if reference considered, whether or not citation is in conformance with MPEP 609. Draw line through a citation if not in conformance and not considered. Include copy of this form with next communication to applicant.

<sup>1</sup> See Kind Codes of USPTO Patent Documents at [www.USPTO.GOV](http://www.USPTO.GOV) or MPEP 901.04. <sup>2</sup> Enter office that issued the document, by the two-letter code (WIPO Standard ST.3). <sup>3</sup> For Japanese patent documents, the indication of the year of the reign of the Emperor must precede the serial number of the patent document. <sup>4</sup> Kind of document by the appropriate symbols as indicated on the document under WIPO Standard ST.16 if possible. <sup>5</sup> Applicant is to place a check mark here if English language translation is attached.

<b>INFORMATION DISCLOSURE STATEMENT BY APPLICANT</b> ( Not for submission under 37 CFR 1.99)	Application Number	90013252
	Filing Date	2014-05-22
	First Named Inventor	HARVEY SLEPIAN
	Art Unit	3992
	Examiner Name	England, David E.
	Attorney Docket Number	1089-001

**CERTIFICATION STATEMENT**

Please see 37 CFR 1.97 and 1.98 to make the appropriate selection(s):

That each item of information contained in the information disclosure statement was first cited in any communication from a foreign patent office in a counterpart foreign application not more than three months prior to the filing of the information disclosure statement. See 37 CFR 1.97(e)(1).

**OR**

That no item of information contained in the information disclosure statement was cited in a communication from a foreign patent office in a counterpart foreign application, and, to the knowledge of the person signing the certification after making reasonable inquiry, no item of information contained in the information disclosure statement was known to any individual designated in 37 CFR 1.56(c) more than three months prior to the filing of the information disclosure statement. See 37 CFR 1.97(e)(2).

See attached certification statement.

The fee set forth in 37 CFR 1.17 (p) has been submitted herewith.

A certification statement is not submitted herewith.

**SIGNATURE**

A signature of the applicant or representative is required in accordance with CFR 1.33, 10.18. Please see CFR 1.4(d) for the form of the signature.

Signature	/Patrick D. Richards/	Date (YYYY-MM-DD)	2014-08-22
Name/Print	Patrick Richards	Registration Number	48905

This collection of information is required by 37 CFR 1.97 and 1.98. The information is required to obtain or retain a benefit by the public which is to file (and by the USPTO to process) an application. Confidentiality is governed by 35 U.S.C. 122 and 37 CFR 1.14. This collection is estimated to take 1 hour to complete, including gathering, preparing and submitting the completed application form to the USPTO. Time will vary depending upon the individual case. Any comments on the amount of time you require to complete this form and/or suggestions for reducing this burden, should be sent to the Chief Information Officer, U.S. Patent and Trademark Office, U.S. Department of Commerce, P.O. Box 1450, Alexandria, VA 22313-1450. **DO NOT SEND FEES OR COMPLETED FORMS TO THIS ADDRESS. SEND TO: Commissioner for Patents, P.O. Box 1450, Alexandria, VA 22313-1450.**

## Privacy Act Statement

The Privacy Act of 1974 (P.L. 93-579) requires that you be given certain information in connection with your submission of the attached form related to a patent application or patent. Accordingly, pursuant to the requirements of the Act, please be advised that: (1) the general authority for the collection of this information is 35 U.S.C. 2(b)(2); (2) furnishing of the information solicited is voluntary; and (3) the principal purpose for which the information is used by the U.S. Patent and Trademark Office is to process and/or examine your submission related to a patent application or patent. If you do not furnish the requested information, the U.S. Patent and Trademark Office may not be able to process and/or examine your submission, which may result in termination of proceedings or abandonment of the application or expiration of the patent.

The information provided by you in this form will be subject to the following routine uses:

1. The information on this form will be treated confidentially to the extent allowed under the Freedom of Information Act (5 U.S.C. 552) and the Privacy Act (5 U.S.C. 552a). Records from this system of records may be disclosed to the Department of Justice to determine whether the Freedom of Information Act requires disclosure of these records.
2. A record from this system of records may be disclosed, as a routine use, in the course of presenting evidence to a court, magistrate, or administrative tribunal, including disclosures to opposing counsel in the course of settlement negotiations.
3. A record in this system of records may be disclosed, as a routine use, to a Member of Congress submitting a request involving an individual, to whom the record pertains, when the individual has requested assistance from the Member with respect to the subject matter of the record.
4. A record in this system of records may be disclosed, as a routine use, to a contractor of the Agency having need for the information in order to perform a contract. Recipients of information shall be required to comply with the requirements of the Privacy Act of 1974, as amended, pursuant to 5 U.S.C. 552a(m).
5. A record related to an International Application filed under the Patent Cooperation Treaty in this system of records may be disclosed, as a routine use, to the International Bureau of the World Intellectual Property Organization, pursuant to the Patent Cooperation Treaty.
6. A record in this system of records may be disclosed, as a routine use, to another federal agency for purposes of National Security review (35 U.S.C. 181) and for review pursuant to the Atomic Energy Act (42 U.S.C. 218(c)).
7. A record from this system of records may be disclosed, as a routine use, to the Administrator, General Services, or his/her designee, during an inspection of records conducted by GSA as part of that agency's responsibility to recommend improvements in records management practices and programs, under authority of 44 U.S.C. 2904 and 2906. Such disclosure shall be made in accordance with the GSA regulations governing inspection of records for this purpose, and any other relevant (i.e., GSA or Commerce) directive. Such disclosure shall not be used to make determinations about individuals.
8. A record from this system of records may be disclosed, as a routine use, to the public after either publication of the application pursuant to 35 U.S.C. 122(b) or issuance of a patent pursuant to 35 U.S.C. 151. Further, a record may be disclosed, subject to the limitations of 37 CFR 1.14, as a routine use, to the public if the record was filed in an application which became abandoned or in which the proceedings were terminated and which application is referenced by either a published application, an application open to public inspections or an issued patent.
9. A record from this system of records may be disclosed, as a routine use, to a Federal, State, or local law enforcement agency, if the USPTO becomes aware of a violation or potential violation of law or regulation.

Doc code: IDS

Doc description: Information Disclosure Statement (IDS) Filed

PTO/SB/08a (01-10)

Approved for use through 07/31/2012. OMB 0651-0031  
U.S. Patent and Trademark Office; U.S. DEPARTMENT OF COMMERCE

Under the Paperwork Reduction Act of 1995, no persons are required to respond to a collection of information unless it contains a valid OMB control number.

<b>INFORMATION DISCLOSURE STATEMENT BY APPLICANT</b> ( Not for submission under 37 CFR 1.99)	Application Number	90013252
	Filing Date	2014-05-22
	First Named Inventor	HARVEY SLEPIAN
	Art Unit	3992
	Examiner Name	England, David E.
	Attorney Docket Number	1089-001

U.S. PATENTS							Remove
Examiner Initial*	Cite No	Patent Number	Kind Code <sup>1</sup>	Issue Date	Name of Patentee or Applicant of cited Document	Pages, Columns, Lines where Relevant Passages or Relevant Figures Appear	
	1						

If you wish to add additional U.S. Patent citation information please click the Add button.

Add

U.S. PATENT APPLICATION PUBLICATIONS							Remove
Examiner Initial*	Cite No	Publication Number	Kind Code <sup>1</sup>	Publication Date	Name of Patentee or Applicant of cited Document	Pages, Columns, Lines where Relevant Passages or Relevant Figures Appear	
	1						

If you wish to add additional U.S. Published Application citation information please click the Add button.

Add

FOREIGN PATENT DOCUMENTS								Remove
Examiner Initial*	Cite No	Foreign Document Number <sup>3</sup>	Country Code <sup>2</sup>	Kind Code <sup>4</sup>	Publication Date	Name of Patentee or Applicant of cited Document	Pages, Columns, Lines where Relevant Passages or Relevant Figures Appear	T <sup>5</sup>
	51	DE 32 18 243 A1	DE		1983-11-17	Lehnert et al.		<input type="checkbox"/>
	52	DE 32 45 752 A1	DE		1983-06-30	Vali-Llovera Passana et al.		<input type="checkbox"/>
	53	DE 32 28 516 A1	DE		1984-04-05	Meyer		<input type="checkbox"/>



**INFORMATION DISCLOSURE  
STATEMENT BY APPLICANT**  
( Not for submission under 37 CFR 1.99)

Application Number	90013252
Filing Date	2014-05-22
First Named Inventor	HARVEY SLEPIAN
Art Unit	3992
Examiner Name	England, David E.
Attorney Docket Number	

<u>54</u>	GB Appln. 2112945	GB		1983-07-27	Vall-Liovera Passana et al.	<input type="checkbox"/>
<u>55</u>	DE 43 26 182 A1	DE		1994-02-17	Schulze	<input type="checkbox"/>
<u>56</u>	DE 35 01 276 C2	DE		1989-07-27	Schimmel et al.	<input type="checkbox"/>
<u>57</u>	DE 32 26 829 A1	DE		1984-01-19	Stelter et al.	<input type="checkbox"/>
<u>58</u>	DE 195 47 375 A1	DE		1997-08-26	Knoll et al.	<input type="checkbox"/>
<u>59</u>	DE 198 47 611 A1	DE		2000-04-20	Heimermann et al.	<input type="checkbox"/>
<u>60</u>	DE 33 34 093 A1	DE		1985-04-11	Rauch	<input type="checkbox"/>
<u>61</u>	DE 29 32 240 A1	DE		1981-02-12	Bechtold et al.	<input type="checkbox"/>
<u>62</u>	DE 32 18 243 C2	DE		1984-04-05	Lehnert et al.	<input type="checkbox"/>
<u>63</u>	EP 0 484 995 A2	EP		1992-05-13	Deering	<input type="checkbox"/>
<u>64</u>	DE 35 01 276 A1	DE		1985-08-01	Schimmel et al.	<input type="checkbox"/>

**INFORMATION DISCLOSURE  
STATEMENT BY APPLICANT**  
( Not for submission under 37 CFR 1.99)

Application Number	90013252
Filing Date	2014-05-22
First Named Inventor	HARVEY SLEPIAN
Art Unit	3992
Examiner Name	England, David E.
Attorney Docket Number	

65	DE 196 46 104 C1	DE	1988-04-02	Hellmann et al.	<input type="checkbox"/>
66	DE 195 39 799 A1	DE	1996-05-09	Vieth	<input type="checkbox"/>

If you wish to add additional Foreign Patent Document citation information please click the Add button

**NON-PATENT LITERATURE DOCUMENTS**

Examiner Initials*	Cite No	Include name of the author (in CAPITAL LETTERS), title of the article (when appropriate), title of the item (book, magazine, journal, serial, symposium, catalog, etc), date, pages(s), volume-issue number(s), publisher, city and/or country where published.	T <sup>5</sup>
	51	VELOCITY PATENT LLC, Case No. 13-CV-08413 Docket # 1 Complaint for Patent Infringement to Mercedes-Benz USA, LLC & Mercedes-Benz U.S. International Inc., U.S. District Court for the Northern District of Illinois Eastern Division, Case Pleading, 2013-11-21, Chicago, Illinois	<input type="checkbox"/>
	52	MERCEDES-BENZ U.S. INTERNATIONAL, INC., 13-CV-08413 Docket # 34 Mercedes-Benz U.S. International's Answer, Affirmative Defenses, and Counterclaim to Velocity's Complaint, U.S. District Court for the Northern District of Illinois Eastern Division, Case Pleading, 2014-01-27, Chicago, Illinois.	<input type="checkbox"/>
	53	MERCEDES-BENZ USA, LLC, 13-CV-08413 Docket # 35 Mercedes-Benz USA's Answer, Affirmative Defenses, and Counterclaim to Velocity's Complaint, U.S. District Court for the Northern District of Illinois Eastern Division, Case Pleading, 2014-01-27, Chicago, Illinois.	<input type="checkbox"/>
	54	VELOCITY PATENT LLC, 13-CV-08413 Docket # 44 Velocity's Answer to Defendant Mercedes-Benz U.S. International's Counterclaim, U.S. District Court for the Northern District of Illinois Eastern Division, Case Pleading, 2014-02-18, Chicago, Illinois.	<input type="checkbox"/>
	55	VELOCITY PATENT LLC, 13-CV-08413 Docket # 45 Velocity's Answer to Defendant Mercedes-Benz USA's Counterclaim, U.S. District Court for the Northern District of Illinois Eastern District, Case Pleading, 2014-02-18, Chicago, Illinois.	<input type="checkbox"/>
	56	VELOCITY PATENT LLC, Velocity's Preliminary Infringement Contentions Against BMW Defendants Pursuant to Northern District of Illinois Local Patent Rule 2.1, U.S. District Court for the Northern District of Illinois Eastern District, Case Discovery, 2014-03-12, Chicago, Illinois.	<input type="checkbox"/>
	57	P. FANCHER, R. ERVIN, S. BOGARD, A Field Operational Test of Adaptive Cruise Control System Operability in Naturalistic Use, Technical Paper Series, 1998-02-23, 14 Pages, Society of Automotive Engineers, Inc. Technical Paper Series, Detroit, Michigan.	<input type="checkbox"/>

**INFORMATION DISCLOSURE  
STATEMENT BY APPLICANT**  
( Not for submission under 37 CFR 1.99)

Application Number	90019252
Filing Date	2014-05-22
First Named Inventor	HARVEY SLEPIAN
Art Unit	3992
Examiner Name	England, David E.
Attorney Docket Number	

58	P.A. IOANNOU, F. AHMED-ZAID, D.H. WUJH, A Time Headway Autonomous Intelligent Cruise Controller: Design and Simulation, Report, April 1994, 32 Pages, California PATH Program of the University of California.	<input type="checkbox"/>
59	GERHARD NÖCKER, Daimler-Benz AG, Abschlußbericht Prometheus Phase II, Study, 1989, 11 Pages, BMW, Daimler-Benz, FIAT, Jaguar, MAN, Matra, Opel, PSA, Renault, Saab, Volvo, VW, Germany	<input type="checkbox"/>
60	ROBERT D. ERVIN, ANU NAGARAJAN, EDWARD S. ARGALAS, Adaptive Cruise Control: An industry Outlook on Product Features and Marketing, Report, October 1997, 110 Pages, U.S. Dept. of Transportation and the University of Michigan ITS Research Center of Excellence.	<input type="checkbox"/>
61	HERMANN WINNER, STEFAN WITTE, WERNER UHLER, BERND LICHTENBERG, Adaptive Cruise Control System Aspects and Development Trends, Technical Paper, 1996-02-28, 12 Pages, Society of Automotive Engineers, Inc. Technical Paper Series, Detroit, Michigan.	<input type="checkbox"/>
62	D. HROVAT & J. JOHNSON, Title: Automotive Control Systems: Past, Present, Future, Paper, Date: September 1991, 6 Pages, Ford Motor Company.	<input type="checkbox"/>
63	Automotive Handbook 3rd Edition, Book, 1993, 51 Pages, ROBERT BOSCH GMBH, Stuttgart, Germany.	<input type="checkbox"/>
64	A. L. MERLO, Automotive Radar for the Prevention of Collisions, Technical Paper, 6 Pages, The Bendix Corporation Research Laboratories Division, Southfield, Michigan.	<input type="checkbox"/>
65	A. BASTIAN, P. ANDREAS, R. HOLZE and R. BERGHOLZ, Autonomous Cruise Control: A First Step Towards Automated Driving, Technical Paper, 1998-08-11, pp. 1-6, Society of Automotive Engineers Technical Paper Series.	<input type="checkbox"/>
66	GERHARD NÖCKER, Abstandsregelung Autonomous Intelligent Cruise Control, Paper, 1990, pp. 327-336, VDI Berichte.	<input type="checkbox"/>
67	RAY W. MURPHY, RUDOLF LIMPERT, LEONARD SEGEL, Bus, Truck, Tractor/Trailer Braking System Performance, Summary Final Report, January 1970, pp. 1-46, Highway Safety Research Institute and the University of Michigan.	<input type="checkbox"/>
68	M.J. RICHARDSON and DAVID SMITH, Design of the Driver Interface for Autonomous Intelligent Cruise Control, Colloquium, 1995-01-19, pp. 7/1-7/4, Colloquium on Design of the Driver Interface.	<input type="checkbox"/>

**INFORMATION DISCLOSURE  
STATEMENT BY APPLICANT**  
( Not for submission under 37 CFR 1.99)

Application Number	90013252
Filing Date	2014-05-22
First Named Inventor	HARVEY SLEPIAN
Art Unit	3992
Examiner Name	England, David E.
Attorney Docket Number	

<u>69</u>	PROF. DR. BERTHOLD FÄRBER, Designing a Distance Warning System From The User's Point of View, Report, 1991-02-28, pp.1-16, Institut für Arbeitspsychologie und interdisziplinäre Systemforschung.	<input type="checkbox"/>
<u>70</u>	JAMES E. STEVENS and LOUIS L. NAGY, Duplex Doppler Radar for Automotive Obstacle Detection, Technical Paper, May 1974, pp. 34-44, IEEE Transactions on Vehicular Technology.	<input type="checkbox"/>
<u>71</u>	K. NAAB and G. REICHART, Driver Assistance Systems for Lateral and Longitudinal Vehicle Guidance - Heading Control and Active Cruise Support, Symposium, 1994-10-25, pp. 1-6, International Symposium on Advanced Vehicle Control.	<input type="checkbox"/>
<u>72</u>	JACEK MALEC, MAGNUS MORIN, and ULF PALMQVIST, Driver Support in Intelligent Autonomous Cruise Control, Article, pp. 160-164, Driver Assistance and Local Traffic Management - Swedish RTI Research Program.	<input type="checkbox"/>
<u>73</u>	PETE TINKER, RONALD AZUMA, CHERYL HEIN, and MIKE DAILY, Driving Simulation for Crash Avoidance Warning Evaluation, Symposium, 1996-06-3, pp. 367-384, Proceedings of the 29th ISATA Dedicated Conference on Simulation, Diagnosis and Virtual Reality in the Automotive Industry.	<input type="checkbox"/>
<u>74</u>	PAUL S. FANCHER, ZEVI BAREKET, JAMES R. SAYER, GREGORY E. JOHNSON, ROBERT D. ERVIN, and MARY LYNN MEFFORD, Fostering Development, Evaluation and Deployment of Forward Crash Avoidance Systems (FOCAS), Annual Research Report, 1995-05-15, pp. 1-170, University of Michigan Transportation Research Institute.	<input type="checkbox"/>
<u>75</u>	PAUL S. FANCHER, ZEVI BAREKET, JAMES R. SAYER, GREGORY E. JOHNSON, ROBERT D. ERVIN, and MARY LYNN MEFFORD, Fostering Development, Evaluation and Deployment of Forward Crash Avoidance System (FOCAS), 1995-05-15, pp. 1-164, National Highway Traffic Safety Administration - U.S. Dept. of Transportation.	<input type="checkbox"/>
<u>76</u>	STEFAN ULVELAND and EYVIND STADIG, Increasing Mileage with an Adaptive Microprocessor Shift Indicator, Technical Paper, 1985-02-25, pp. 55-56, Society of Automotive Engineers Technical Paper Series.	<input type="checkbox"/>
<u>77</u>	P. FANCHER, R. ERVIN, J. SAYER, M. HAGAN, S. BOGARD, Z. BAREKET, M. MEFFORD, and J. HAUGEN, Intelligent Cruise Control Field Operational Test, Final Report, May 1998, pp. 1-558, U.S. Department of Transportation - National Highway Traffic Safety Administration.	<input type="checkbox"/>
<u>78</u>	ULF PALMQVIST, Intelligent Cruise Control: A Key Component Towards Improved Traffic Flow Control, Report, pp. 56-59.	<input type="checkbox"/>
<u>79</u>	J. GROGAN, D. A. MORRIS, S.W. SEARCY, and B.A. STOUT, Microcomputer-based Tractor Performance Monitoring and Optimization System, Journal, 1987, pp. 227-243, The British Society For Research in Agricultural Engineering.	<input type="checkbox"/>

**INFORMATION DISCLOSURE  
STATEMENT BY APPLICANT**  
( Not for submission under 37 CFR 1.99)

Application Number	90013252
Filing Date	2014-05-22
First Named Inventor	HARVEY SLEPIAN
Art Unit	3992
Examiner Name	England, David E.
Attorney Docket Number	

<u>80</u>	CLEMENT B. SOMUAH, ANDREW F. BURKE, BIMAL K. BOSE, ROBERT D. KING, and MICHAEL A. POCOBELLO, A Microcomputer-Controlled Powertrain for a Hybrid Vehicle, May 1983, pp. 126-131, IEEE Transactions On Industrial Electronics.	<input type="checkbox"/>
<u>81</u>	7 Series Owner's Handbook, Manual, 1993, pp. 2-132, BMW AG, Germany.	<input type="checkbox"/>
<u>82</u>	COMSIS CORPORATION, Preliminary Human Factors Guidelines For Crash Avoidance Warning Devices, Report, January 1996, pp. 1-175, U.S. Department of Transportation National Highway Traffic Safety Administration.	<input type="checkbox"/>
<u>83</u>	ALFRED HOESS, Realisation of an Intelligent Cruise Control System Utilizing Classification of Distance, Relative Speed and Vehicle Speed Information, Article.	<input type="checkbox"/>
<u>84</u>	Road Vehicles - Adaptive Cruise Control Systems - Performance Requirements and Test Procedures, Draft International Standard, 1999-07-19, pp. 1-32, ISO.	<input type="checkbox"/>
<u>85</u>	Electronic Data Interchange Between Microcomputer Systems in Heavy-Duty Vehicle Applications, Report, January 2013, pp. 1-268, Society of Automotive Engineers.	<input type="checkbox"/>
<u>86</u>	Serial Data Communications Between Microcomputer Systems in Heavy-Duty Vehicle Applications, Report, December 2010, pp. 1-14, Society of Automotive Engineers.	<input type="checkbox"/>
<u>87</u>	Powertrain Control Interface for Electronic Controls Used in Medium- and Heavy-Duty Diesel On-Highway Vehicle Applications, Report, August 2011, pp. 1-18, Society of Automotive Engineers.	<input type="checkbox"/>
<u>88</u>	Serial Control and Communications Heavy Duty Vehicle Network - Top Level Document, Report, August 2013, pp. 1-29, Society of Automotive Engineers.	<input type="checkbox"/>
<u>89</u>	P. FANCHER, Z. BAREKET, S. BOGARD, C. MACADAM, and R. ERVIN, Tests Characterizing Performance of an Adaptive Cruise Control System, Technical Paper, 1997-02-24, pp. 1-12, Society of Automotive Engineers Technical Paper Series.	<input type="checkbox"/>
<u>90</u>	The Computerized Family Car will be Commonplace in Europe Before the End of the Decade, Journal, September 1982, pp. 1-8.	<input type="checkbox"/>

**INFORMATION DISCLOSURE  
STATEMENT BY APPLICANT**  
( Not for submission under 37 CFR 1.99)

Application Number	90013252
Filing Date	2014-05-22
First Named Inventor	HARVEY SLEPIAN
Art Unit	3992
Examiner Name	England, David E.
Attorney Docket Number	

91	PAUL GREEN, What Do Drivers Say They Use Speedometers and Tachometers For?, Report, October 1983, pp. 1-40, University of Michigan Transportation Research Institute.	<input type="checkbox"/>
----	---	--------------------------

If you wish to add additional non-patent literature document citation information please click the Add button

**EXAMINER SIGNATURE**

Examiner Signature		Date Considered	
--------------------	--	-----------------	--

\*EXAMINER: Initial if reference considered, whether or not citation is in conformance with MPEP 609. Draw line through a citation if not in conformance and not considered. Include copy of this form with next communication to applicant.

<sup>1</sup> See Kind Codes of USPTO Patent Documents at [www.USPTO.GOV](http://www.USPTO.GOV) or MPEP 901.04. <sup>2</sup> Enter office that issued the document, by the two-letter code (WIPO Standard ST.3). <sup>3</sup> For Japanese patent documents, the indication of the year of the reign of the Emperor must precede the serial number of the patent document. <sup>4</sup> Kind of document by the appropriate symbols as indicated on the document under WIPO Standard ST.16 if possible. <sup>5</sup> Applicant is to place a check mark here if English language translation is attached.

**INFORMATION DISCLOSURE  
STATEMENT BY APPLICANT**  
( Not for submission under 37 CFR 1.99)

Application Number	90013252
Filing Date	2014-05-22
First Named Inventor	HARVEY SLEPIAN
Art Unit	3992
Examiner Name	England, David E.
Attorney Docket Number	

**CERTIFICATION STATEMENT**

Please see 37 CFR 1.97 and 1.98 to make the appropriate selection(s):

That each item of information contained in the information disclosure statement was first cited in any communication from a foreign patent office in a counterpart foreign application not more than three months prior to the filing of the information disclosure statement. See 37 CFR 1.97(e)(1).

**OR**

That no item of information contained in the information disclosure statement was cited in a communication from a foreign patent office in a counterpart foreign application, and, to the knowledge of the person signing the certification after making reasonable inquiry, no item of information contained in the information disclosure statement was known to any individual designated in 37 CFR 1.56(c) more than three months prior to the filing of the information disclosure statement. See 37 CFR 1.97(e)(2).

See attached certification statement.

The fee set forth in 37 CFR 1.17 (p) has been submitted herewith.

A certification statement is not submitted herewith.

**SIGNATURE**

A signature of the applicant or representative is required in accordance with CFR 1.33, 10.18. Please see CFR 1.4(d) for the form of the signature.

Signature	/Patrick D. Richards/	Date (YYYY-MM-DD)	08/22/14
Name/Print	Patrick Richards	Registration Number	48905

This collection of information is required by 37 CFR 1.97 and 1.98. The information is required to obtain or retain a benefit by the public which is to file (and by the USPTO to process) an application. Confidentiality is governed by 35 U.S.C. 122 and 37 CFR 1.14. This collection is estimated to take 1 hour to complete, including gathering, preparing and submitting the completed application form to the USPTO. Time will vary depending upon the individual case. Any comments on the amount of time you require to complete this form and/or suggestions for reducing this burden, should be sent to the Chief Information Officer, U.S. Patent and Trademark Office, U.S. Department of Commerce, P.O. Box 1450, Alexandria, VA 22313-1450. **DO NOT SEND FEES OR COMPLETED FORMS TO THIS ADDRESS. SEND TO: Commissioner for Patents, P.O. Box 1450, Alexandria, VA 22313-1450.**

## Electronic Acknowledgement Receipt

<b>EFS ID:</b>	19947063
<b>Application Number:</b>	90013252
<b>International Application Number:</b>	
<b>Confirmation Number:</b>	9999
<b>Title of Invention:</b>	Method and Apparatus for Optimizing Vehicle Operation
<b>First Named Inventor/Applicant Name:</b>	5,954,781
<b>Customer Number:</b>	88360
<b>Filer:</b>	Patrick Duffy Richards
<b>Filer Authorized By:</b>	
<b>Attorney Docket Number:</b>	
<b>Receipt Date:</b>	22-AUG-2014
<b>Filing Date:</b>	22-MAY-2014
<b>Time Stamp:</b>	20:16:40
<b>Application Type:</b>	Reexam (Third Party)

### Payment information:

Submitted with Payment	no
------------------------	----

### File Listing:

Document Number	Document Description	File Name	File Size(Bytes)/ Message Digest	Multi Part /.zip	Pages (if appl.)
1	Information Disclosure Statement (IDS) Form (SB08)	IDS1of2.pdf	618527 b92510c4ad2fd26faaf573633fac0f3114fc00d	no	24

### Warnings:

### Information:



2	Other Reference-Patent/App/Search documents	BMW1to12.pdf	10746275	no	1584
			d0faff4e68a3658473074c17ba89112032b4b13b		
<b>Warnings:</b>					
<b>Information:</b>					
3	Other Reference-Patent/App/Search documents	BMW13to24.pdf	3761513	no	561
			ce004ab84759c878a7218bf790f935291b43882c		
<b>Warnings:</b>					
<b>Information:</b>					
4	Other Reference-Patent/App/Search documents	BMW25to28.pdf	8384403	no	1210
			a3b1cd07cf7967ad956763bad528a30cf9215268		
<b>Warnings:</b>					
<b>Information:</b>					
5	Other Reference-Patent/App/Search documents	Chrysler1to12.pdf	3979275	no	537
			6cc6e80d6cf9b864f9f3f5f9e6607b65edea258		
<b>Warnings:</b>					
<b>Information:</b>					
6	Other Reference-Patent/App/Search documents	Chrysler13to24.pdf	4163075	no	554
			8b01a8b501ee88677848fa0e8f379a81cbcb0ff8		
<b>Warnings:</b>					
<b>Information:</b>					
7	Other Reference-Patent/App/Search documents	Chrysler25to26.pdf	8723966	no	1154
			596517ddf99be3c00b7209b738113c19b92f493		
<b>Warnings:</b>					
<b>Information:</b>					
8	Other Reference-Patent/App/Search documents	Jaguar1to12.pdf	4089449	no	537
			b5fe11595ab2ec7c30e24c32f6e60ef16170d2a		
<b>Warnings:</b>					
<b>Information:</b>					
9	Other Reference-Patent/App/Search documents	Jaguar13to24.pdf	4147283	no	554
			c8875047c320d930622136115ebe7ccd38a3d56		
<b>Warnings:</b>					
<b>Information:</b>					
10	Other Reference-Patent/App/Search documents	Jaguar25to36.pdf	4089470	no	537
			aba852bee39df311c7a80458564e92a09edc1e3a		
<b>Warnings:</b>					
<b>Information:</b>					

11	Other Reference-Patent/App/Search documents	Jaguar37to48.pdf	4147364	no	554
			61dff19cfc27130f62f949e1cd25799912121 eea		
<b>Warnings:</b>					
<b>Information:</b>					
12	Other Reference-Patent/App/Search documents	Jaguar49to50.pdf	571768	no	62
			239e65888bafd92e0010e2b77f3434074c 7011e		
<b>Warnings:</b>					
<b>Information:</b>					
13	Other Reference-Patent/App/Search documents	Mercedes1to12.pdf	17721428	no	2869
			b5f5116091e9cf46728c9b06773a0c2e8510a 1a21		
<b>Warnings:</b>					
<b>Information:</b>					
14	Other Reference-Patent/App/Search documents	Mercedes13to24.pdf	3650658	no	559
			379b93eb136bea38b83959a23259b5d7d1 a4f599		
<b>Warnings:</b>					
<b>Information:</b>					
15	Other Reference-Patent/App/Search documents	Mercedes25to36.pdf	3374551	no	522
			1f8c72b9abe33353ec3306b81b4d30d8bee bdbbc		
<b>Warnings:</b>					
<b>Information:</b>					
16	Other Reference-Patent/App/Search documents	Mercedes37to48.pdf	53161	no	1
			91c66350a8a2393aaa26cafa437e6f0e92f5 916		
<b>Warnings:</b>					
<b>Information:</b>					
17	Other Reference-Patent/App/Search documents	Mercedes49to52.pdf	1243929	no	185
			7815da296aa8315e58b296e7f4136337b30 5bc5c		
<b>Warnings:</b>					
<b>Information:</b>					
18	Other Reference-Patent/App/Search documents	Audi.pdf	17409043	no	1875
			4b71d31b31c5c721b2bda417b2abe78ec0 d17f53		
<b>Warnings:</b>					
<b>Information:</b>					
19	Other Reference-Patent/App/Search documents	Audi5and6.pdf	277309	no	20
			4bf11e1a826f8c73e721f0c106b1deac3e13 76e1		
<b>Warnings:</b>					
<b>Information:</b>					

20	Information Disclosure Statement (IDS) Form (SB08)	IDSform2.pdf	717557 4c59382cfb2195bf6fd1a42279d458d7ede70c9d	no	8
<b>Warnings:</b>					
<b>Information:</b>					
This is not an USPTO supplied IDS fillable form					
<b>Total Files Size (in bytes):</b>			101870004		
<p><b>This Acknowledgement Receipt evidences receipt on the noted date by the USPTO of the indicated documents, characterized by the applicant, and including page counts, where applicable. It serves as evidence of receipt similar to a Post Card, as described in MPEP 503.</b></p> <p><b><u>New Applications Under 35 U.S.C. 111</u></b>  <b>If a new application is being filed and the application includes the necessary components for a filing date (see 37 CFR 1.53(b)-(d) and MPEP 506), a Filing Receipt (37 CFR 1.54) will be issued in due course and the date shown on this Acknowledgement Receipt will establish the filing date of the application.</b></p> <p><b><u>National Stage of an International Application under 35 U.S.C. 371</u></b>  <b>If a timely submission to enter the national stage of an international application is compliant with the conditions of 35 U.S.C. 371 and other applicable requirements a Form PCT/DO/EO/903 indicating acceptance of the application as a national stage submission under 35 U.S.C. 371 will be issued in addition to the Filing Receipt, in due course.</b></p> <p><b><u>New International Application Filed with the USPTO as a Receiving Office</u></b>  <b>If a new international application is being filed and the international application includes the necessary components for an international filing date (see PCT Article 11 and MPEP 1810), a Notification of the International Application Number and of the International Filing Date (Form PCT/RO/105) will be issued in due course, subject to prescriptions concerning national security, and the date shown on this Acknowledgement Receipt will establish the international filing date of the application.</b></p>					

Organization \_\_\_\_\_ Bldg/Room \_\_\_\_\_  
United States Patent and Trademark Office  
P.O. Box 1450  
Alexandria, VA 22313-1450  
If Undeliverable Return in Ten Day \_\_\_\_\_

OFFICIAL BUSINESS  
PENALTY FOR PRIVATE USE, \$300

AN EQUAL OPPORTUNITY EMPLOYER



UNITED STATES POSTAGE  
02 1M  
\$00.48<sup>0</sup>  
0008003350 JUL 11 2014  
MAILED FROM ZIP CODE 22206

**RECEIVED**  
JUL 22 2014  
USPTO... CENTER 17/14

NIXIE 750  
RETURN TO SENDER  
ATTEMPTED - NOT KNOWN  
UNABLE TO FORWARD

BC: 22313145050 \*1892-07677-11-39

75202327323 004630

Reefam

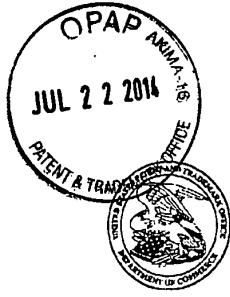

UNITED STATES PATENT AND TRADEMARK OFFICE

UNITED STATES DEPARTMENT OF COMMERCE  
United States Patent and Trademark Office  
Address: COMMISSIONER FOR PATENTS  
P.O. Box 1450  
Alexandria, Virginia 22313-1450  
www.uspto.gov

APPLICATION NUMBER	FILING OR 371(C) DATE	FIRST NAMED APPLICANT	ATTY. DOCKET NO./TITLE
90/013,252	05/22/2014	5,954,781	

CONFIRMATION NO. 9999

POWER OF ATTORNEY NOTICE

MICHAEL S. BUSH  
HAYNES AND BOONE LLP  
3100 NATIONSBANK PLAZA  
901 MAIN STREET  
DALLAS, TX 75202-3789



Date Mailed: 07/02/2014

NOTICE REGARDING CHANGE OF POWER OF ATTORNEY

This is in response to the Power of Attorney filed 06/27/2014.

- The Power of Attorney to you in this application has been revoked by the assignee who has intervened as provided by 37 CFR 3.71. Future correspondence will be mailed to the new address of record(37 CFR 1.33).

/jawhitfield/

Office of Data Management, Application Assistance Unit (571) 272-4000, or (571) 272-4200, or 1-888-786-0101



UNITED STATES PATENT AND TRADEMARK OFFICE

UNITED STATES DEPARTMENT OF COMMERCE  
United States Patent and Trademark Office  
Address: COMMISSIONER FOR PATENTS  
P.O. Box 1450  
Alexandria, Virginia 22313-1450  
www.uspto.gov

APPLICATION NUMBER	FILING OR 371(C) DATE	FIRST NAMED APPLICANT	ATTY. DOCKET NO./TITLE
90/013,252	05/22/2014	5,954,781	

88360  
Richards Patent Law P.C.  
233 S. Wacker Dr., 84th Floor  
Chicago, IL 60606

**CONFIRMATION NO. 9999**  
**POA ACCEPTANCE LETTER**



Date Mailed: 07/02/2014

**NOTICE OF ACCEPTANCE OF POWER OF ATTORNEY**

This is in response to the Power of Attorney filed 06/27/2014.

The Power of Attorney in this application is accepted. Correspondence in this application will be mailed to the above address as provided by 37 CFR 1.33.

/jawhitfield/

Office of Data Management, Application Assistance Unit (571) 272-4000, or (571) 272-4200, or 1-888-786-0101



UNITED STATES PATENT AND TRADEMARK OFFICE

UNITED STATES DEPARTMENT OF COMMERCE  
United States Patent and Trademark Office  
Address: COMMISSIONER FOR PATENTS  
P.O. Box 1450  
Alexandria, Virginia 22313-1450  
www.uspto.gov

APPLICATION NO.	FILING DATE	FIRST NAMED INVENTOR	ATTORNEY DOCKET NO.	CONFIRMATION NO.
90/013,252	05/22/2014	5,954,781		9999

88360 7590 07/21/2014  
Richards Patent Law P.C.  
233 S. Wacker Dr., 84th Floor  
Chicago, IL 60606

EXAMINER

ENGLAND, DAVID E

ART UNIT PAPER NUMBER

3992

MAIL DATE DELIVERY MODE

07/21/2014

PAPER

**Please find below and/or attached an Office communication concerning this application or proceeding.**

The time period for reply, if any, is set in the attached communication.



UNITED STATES PATENT AND TRADEMARK OFFICE

Commissioner for Patents  
United States Patent and Trademark Office  
P.O. Box 1450  
Alexandria, VA 22313-1450  
[www.uspto.gov](http://www.uspto.gov)

**DO NOT USE IN PALM PRINTER**

(THIRD PARTY REQUESTER'S CORRESPONDENCE ADDRESS)

KENYON & KENYON LLP

ONE BROADWAY

NEW YORK, NY 10004

**EX PARTE REEXAMINATION COMMUNICATION TRANSMITTAL FORM**

REEXAMINATION CONTROL NO. 90/013,252.

PATENT NO. 5,954,781.

ART UNIT 3992.

Enclosed is a copy of the latest communication from the United States Patent and Trademark Office in the above identified *ex parte* reexamination proceeding (37 CFR 1.550(f)).

Where this copy is supplied after the reply by requester, 37 CFR 1.535, or the time for filing a reply has passed, no submission on behalf of the *ex parte* reexamination requester will be acknowledged or considered (37 CFR 1.550(g)).



<b>Ex Parte Reexamination Interview Summary – Pilot Program for Waiver of Patent Owner's Statement</b>	Control No.	Patent Under Reexamination is Requested
	90/013,252	5,954,781
	Examiner	Art Unit
	DAVID ENGLAND	3992

-- The MAILING DATE of this communication appears on the cover sheet with the correspondence address. --

**All participants (USPTO official and patent owner):**

- (1) Sudhanshu C. Pathak, SPRS 3992 (3)  
(2) Alisha bull (4)

Date of Telephonic Interview: 07/17/2014.

**A. The USPTO official requested waiver of the patent owner's statement pursuant to the pilot program for waiver of patent owner's statement in ex parte reexamination proceedings.\***

- The patent owner **agreed** to waive its right to file a patent owner's statement under 35 U.S.C. 304 in the event reexamination is ordered for the above-identified patent.
- The patent owner **did not agree** to waive its right to file a patent owner's statement under 35 U.S.C. 304 at this time.
- USPTO personnel were unable to reach the patent owner.\*\*

**B. The Patent Owner of record telephoned the Office and indicated they would like to participate in the pilot program for waiver of patent owner's statement in ex parte reexamination proceedings.\***

- The Patent owner of record telephoned the Office and **agreed** to waive its right to file a patent owner's statement under 35 U.S.C. 304 in the event reexamination is ordered for the above-identified patent.

The patent owner is not required to file a written statement of this telephone communication under 37 CFR 1.560(b) or otherwise. However, any disagreement as to this interview summary must be brought to the immediate attention of the USPTO, and no later than one month from the mailing date of this interview summary. Extensions of time are governed by 37 CFR 1.550(c).

\*For more information regarding this pilot program, see *Pilot Program for Waiver of Patent Owner's Statement in Ex Parte Reexamination Proceedings*, 75 Fed. Reg. 47269 (August 5, 2010), available on the USPTO Web site at <http://www.uspto.gov/patents/law/notices/2010.jsp>.

\*\*The patent owner may contact the USPTO personnel at (571) 272-7705 or at the telephone number provided below if the patent owner decides to waive the right to file a patent owner's statement under 35 U.S.C. 304.

/Sudhanshu C. Pathak/ (571)272-5509  
Signature and telephone number of the USPTO official, who contacted, was contacted by, or attempted to contact the patent owner.

cc: Requester (if third party requester)



UNITED STATES PATENT AND TRADEMARK OFFICE

Commissioner for Patents  
United States Patents and Trademark Office  
P.O.Box 1450  
Alexandria, VA 22313-1450  
www.uspto.gov

THIRD PARTY REQUESTER'S CORRESPONDENCE ADDRESS

KENYON & KENYON LLP  
ONE BROADWAY  
NEW YORK, NY 10004

Date:

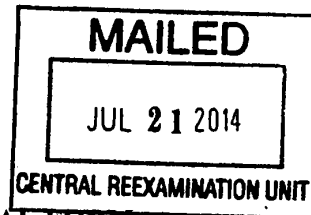

**EX PARTE REEXAMINATION COMMUNICATION TRANSMITTAL FORM**

REEXAMINATION CONTROL NO. : 90013252  
PATENT NO. : 5954781  
ART UNIT : 3993

Enclosed is a copy of the latest communication from the United States Patent and Trademark Office in the above identified ex parte reexamination proceeding (37 CFR 1.550(f)).

Where this copy is supplied after the reply by requester, 37 CFR 1.535, or the time for filing a reply has passed, no submission on behalf of the ex parte reexamination requester will be acknowledged or considered (37 CFR 1.550(g)).



UNITED STATES PATENT AND TRADEMARK OFFICE

*Reexam*

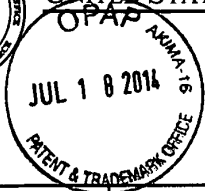

UNITED STATES DEPARTMENT OF COMMERCE  
United States Patent and Trademark Office  
Address: COMMISSIONER FOR PATENTS  
P.O. Box 1450  
Alexandria, Virginia 22313-1450  
www.uspto.gov

APPLICATION NO.	FILING DATE	FIRST NAMED INVENTOR	ATTORNEY DOCKET NO.	CONFIRMATION NO.
90/013,252	05/22/2014	5,954,781		9999

7590 06/27/2014  
 MICHAEL S. BUSH  
 HAYNES AND BOONE LLP  
 3100 NATIONSBANK PLAZA  
 901 MAIN STREET  
 DALLAS, TX 75202-3789

EXAMINER

ENGLAND, DAVID E

ART UNIT	PAPER NUMBER
----------	--------------

3992

MAIL DATE	DELIVERY MODE
-----------	---------------

06/27/2014

PAPER

**Please find below and/or attached an Office communication concerning this application or proceeding.**

The time period for reply, if any, is set in the attached communication.



UNITED STATES PATENT AND TRADEMARK OFFICE

Commissioner for Patents  
United States Patent and Trademark Office  
P.O. Box 1450  
Alexandria, VA 22313-1450  
www.uspto.gov



**DO NOT USE IN PALM PRINTER**

(THIRD PARTY REQUESTER'S CORRESPONDENCE ADDRESS)

KENYON & KENYON LLP  
ONE BROADWAY  
NEW YORK, NY 10004

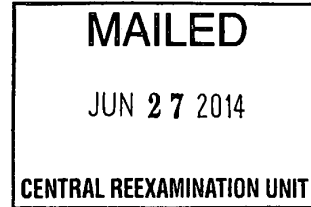

**EX PARTE REEXAMINATION COMMUNICATION TRANSMITTAL FORM**

REEXAMINATION CONTROL NO. 90/013,252.

PATENT NO. 5,954,781.

ART UNIT 3992.

Enclosed is a copy of the latest communication from the United States Patent and Trademark Office in the above identified *ex parte* reexamination proceeding (37 CFR 1.550(f)).

Where this copy is supplied after the reply by requester, 37 CFR 1.535, or the time for filing a reply has passed, no submission on behalf of the *ex parte* reexamination requester will be acknowledged or considered (37 CFR 1.550(g)).



**Order Granting / Denying Request For Ex Parte Reexamination**

Control No. 90/013,252	Patent Under Reexamination 5,954,781
Examiner DAVID ENGLAND	Art Unit 3992

--The MAILING DATE of this communication appears on the cover sheet with the correspondence address--

The request for *ex parte* reexamination filed **22 May 2014** has been considered and a determination has been made. An identification of the claims, the references relied upon, and the rationale supporting the determination are attached.

Attachments: a)  PTO-892, b)  PTO/SB/08, c)  Other: IDS List

1.  The request for *ex parte* reexamination is GRANTED.

**RESPONSE TIMES ARE SET AS FOLLOWS:**

For Patent Owner's Statement (Optional): **TWO MONTHS** from the mailing date of this communication (37 CFR 1.530 (b)). **EXTENSIONS OF TIME ARE GOVERNED BY 37 CFR 1.550(c).**

For Requester's Reply (optional): **TWO MONTHS** from the **date of service** of any timely filed Patent Owner's Statement (37 CFR 1.535). **NO EXTENSION OF THIS TIME PERIOD IS PERMITTED.** If Patent Owner does not file a timely statement under 37 CFR 1.530(b), then no reply by requester is permitted.

2.  The request for *ex parte* reexamination is DENIED.

This decision is not appealable (35 U.S.C. 303(c)). Requester may seek review by petition to the Commissioner under 37 CFR 1.181 within **ONE MONTH** from the mailing date of this communication (37 CFR 1.515(c)). **EXTENSION OF TIME TO FILE SUCH A PETITION UNDER 37 CFR 1.181 ARE AVAILABLE ONLY BY PETITION TO SUSPEND OR WAIVE THE REGULATIONS UNDER 37 CFR 1.183.**

In due course, a refund under 37 CFR 1.26 ( c ) will be made to requester:

- a)  by Treasury check or,
- b)  by credit to Deposit Account No. \_\_\_\_\_, or
- c)  by credit to a credit card account, unless otherwise notified (35 U.S.C. 303(c)).

/DAVID ENGLAND/  
Primary Examiner, Art Unit 3992

cc:Requester ( if third party requester )

Art Unit: 3992

1. The present application is being examined under the pre-AIA first to invent provisions.

### **DECISION GRANTING EX PARTE REEXAMINATION**

A Request for *ex parte* reexamination affecting claims 1, 2, 4, 5, 7, 8, 10, 12, 13, 15 and 17 – 32 of United States Patent Number 5,954,781 (hereafter “the ‘781 Patent”) has been submitted on 05/22/2014.

Extensions of time under 37 CFR 1.136(a) will not be permitted in these proceedings because the provisions of 37 CFR 1.136 apply only to "an applicant" and not to parties in a reexamination proceeding. Additionally, 35 U.S.C. 305 requires that *ex parte* reexamination proceedings "will be conducted with special dispatch" (37 CFR 1.550(a)). Extensions of time in *ex parte* reexamination proceedings are provided for in 37 CFR 1.550(c).

### **Prosecution History**

The ‘781 Patent was issued on September 21 1999 from U.S. Application Serial No. 08/813,270, hereinafter “the ‘270 Application”, filed on March 10, 1997.

The prosecution history of the ‘781 Patent includes:

The '270 application was filed on March 10, 1997 with 32 claims, of which application claims 1, 14, 18, and 27 were the only independent claims. Among these independent claims, application claim 1 included a fuel overinjection circuit, application claim 14 included a fuel overinjection circuit, an upshift notification circuit, and a downshift notification circuit,

Art Unit: 3992

application claim 18 included a vehicle proximity alarm, and application claim 27 included a fuel overinjection circuit and a vehicle proximity alarm.

In the only Office Action, dated August 6, 1998, application claims 1, 2 and 4 to 6 were rejected as obvious in view of U.S. Patent No. 4,901,701 to Chasteen (copy attached as Exhibit 3), application claim 3 was rejected as obvious in view of the combination of Chasteen and U.S. Patent No. 4,631,515 to Blee et al. (copy attached as Exhibit 4), and application claims 7, 18 to 24, 27, and 28 were rejected as obvious in view of the combination of Chasteen and U.S. Patent No. 5,708,584 to Doi et al. (copy attached as Exhibit 5).

In the Office Action, the Examiner stated that application claims 8 to 13, 25, 26, and 29 to 32 included allowable subject matter. Specifically, the Examiner stated that application claims 8, 25, and 29 included allowable subject matter on the basis that "the prior art fails to disclose an upshift notification circuit coupled to the processor subsystem, the upshift notification circuit issuing a notification that the engine of the vehicle is being operated at an excessive engine speed and the processor determines when to activate the upshift notification circuit." Similarly, the Examiner stated that application claims 11, 26, and 31 included allowable subject matter on the basis that "the prior art fails to disclose a downshift notification circuit coupled to the processor subsystem, the downshift notification circuit issuing a notification that the engine of the vehicle is being operated at an insufficient engine speed and the processor determines when to activate the downshift notification circuit." In addition, application claims 14 - 17, which included both an upshift notification circuit and a downshift notification circuit, were allowed on the basis that:

the prior art fails to disclose an upshift notification circuit coupled to the processor subsystem, the upshift notification circuit issuing a notification that the engine of the vehicle is being operated at an excessive engine speed and the processor determines when to activate the upshift notification circuit and a downshift notification circuit coupled to the processor subsystem, the downshift notification circuit issuing a notification that the engine of the vehicle is being operated at an insufficient engine speed and the processor determines when to activate the downshift notification circuit.

In response to this Office Action, the applicant submitted an Amendment on February 8, 1999 with numerous amendments, see the response to Office Action and the Request pages 6 – 13 for further explanation. The '270 Application was subsequently allowed, see Notice of Allowance dated 04/21/1999 or the Request pages 13 and 14 for further details. The Examiner stated in their reasons for allowance that:

The prior art fails to disclose an apparatus for optimizing operation of a vehicle and comprising an upshift notification circuit coupled to the processor subsystem, the upshift notification circuit issuing a notification that the engine of the vehicle is being operated at an excessive speed and the processor determines when to activate the upshift notification circuit; and a downshift notification circuit coupled to the processor subsystem, the downshift notification circuit issuing



a notification that the engine of the vehicle is being operated at an insufficient engine speed and the processor determines when to activate the downshift notification circuit.

The Notice of Allowance further states that:

Nor does the prior art disclose [sic] a fuel overinjection notification circuit coupled to the processor subsystem, wherein the fuel overinjection notification circuit issuing a notification that excess fuel is being supplied to the engine of the vehicle and the processor subsystem determining whether to activate the fuel overinjection notification circuit based upon data received from the road speed sensor, the throttle position sensor and the manifold sensor.

Additionally, the Notice of Allowance states:

Nor does the prior art disclose [sic] that the processor subsystem determines whether to activate the vehicle proximity alarm circuit based upon separation distance data received from the radar detector, vehicle speed, stopping distance table stored in the memory subsystem.

### Proposed Substantial New Question of Patentability

Third Party Requester ("Requester") identifies the following printed publications as evidence that a substantial new question should be raised in the Request, see pp. 15-16.

1. Automotive Electronics Handbook, by Ronald Jurgen ("Jurgen"), attached as exhibit 11.
2. U.S. Patent No. 5,477,452 to Milunas et al. ("Saturn '452"), attached as exhibit 12.
3. U.S. Patent No. 4,559,599 to Habu et al. ("Toyota '599"), attached as exhibit 13.
4. German Patent Application Publication No. 29 26 070 ("Volkswagen '070"), attached as exhibit 14.
5. U.S. Patent No. 5,357,438 to Davidian ("Davidian"), attached as exhibit 15.

6. U.S. Patent No. 4,061,055 to Iizuka et al. ("Nissan '055"), attached as exhibit 16.
7. U.S. Patent No. 5,121,324 to Rini et al. ("Mack '324"), attached as exhibit 17.
8. U.S. Patent No. 3,925,753 to Auman et al. ("GM '452"), attached as exhibit 18.
9. PCT Publication No. WO 96/02853 ("Tonkin"), attached as exhibit 19.

Requester has alleged a substantial new question, "SNQ", of patentability in light of proposed rejections which are stated below:

- The 1<sup>st</sup> Proposed Rejection: Claim 1 is alleged as Obvious Under 35 U.S.C. § 103(a) in View of the Combination of Jurgen and Saturn '452.
- The 2<sup>nd</sup> Proposed Rejection: Claims 1, 7, and 13 are alleged as Obvious Under 35 U.S.C. § 103(a) in View of the Combination of Jurgen and Toyota '599.
- The 3<sup>rd</sup> Proposed Rejection: Claims 1, 7, and 13 are alleged as Obvious Under 35 U.S.C. § 103(a) in View of the Combination of Jurgen and Volkswagen '070.
- The 4<sup>th</sup> Proposed Rejection: Claims 17-23 and 26 are alleged as Obvious Under 35 U.S.C. § 103(a) in View of the Combination of Jurgen, Toyota '599, and Davidian.
- The 5<sup>th</sup> Proposed Rejection: Claims 17-23 and 26 are alleged as Obvious Under 35 U.S.C. § 103(a) in View of the Combination of Jurgen, Volkswagen '070, and Davidian.
- The 6<sup>th</sup> Proposed Rejection: Claims 17-21 and 23 are alleged as Obvious Under 35 U.S.C. § 103(a) in View of the Combination of Jurgen, Saturn '452, and Davidian.

Art Unit: 3992

- The 7<sup>th</sup> Proposed Rejection: Claims 28-30 are alleged as Obvious Under 35 U.S.C. § 103(a) in View of the Combination of Jurgen and Nissan '055.
- The 8<sup>th</sup> Proposed Rejection: Claims 28-30 are alleged as Obvious Under 35 U.S.C. § 103(a) in View of the Combination of Jurgen and Mack '324.
- The 9<sup>th</sup> Proposed Rejection: Claims 28-30 are alleged as Obvious Under 35 U.S.C. § 103(a) in View of the Combination of Jurgen and GM '753.
- The 10<sup>th</sup> Proposed Rejection: Claim 31 is alleged as Anticipated Under 35 U.S.C. § 102(b) by Davidian.
- The 11<sup>th</sup> Proposed Rejection: Claims 31 and 32 are alleged as Obvious Under 35 U.S.C. § 103(a) in View of the Combination of Tonkin and Doi et al.

Requester has proposed rejections for dependent claims that are not the basis for the SNQ, which are stated below:

- The 12<sup>th</sup> Proposed Rejection: Claims 2, 4, and 5 are alleged as Obvious Under 35 U.S.C. § 103(a) in View of the Combination of Jurgen, Saturn '452, and Chasteen.
- The 13<sup>th</sup> Proposed Rejection: Claims 2, 4, 5, 8, 10, 12, and 15 are alleged as Obvious Under 35 U.S.C. § 103(a) in View of the Combination of Jurgen, Toyota '599, and Chasteen.
- The 14<sup>th</sup> Proposed Rejection: Claims 2, 4, 5, 8, 10, 12, and 15 are alleged as Obvious Under 35 U.S.C. § 103(a) in View of the Combination of Jurgen, Volkswagen '070, and Chasteen.

- The 15<sup>th</sup> Proposed Rejection: Claim 18 is alleged as Obvious Under 35 U.S.C. § 103(a) in View of the Combination of Jurgén, Toyota '599, Davidian, and Tonkin.
- The 16<sup>th</sup> Proposed Rejection: Claim 18 is alleged as Obvious Under 35 U.S.C. § 103(a) in View of the Combination of Jurgén, Volkswagen '070, Davidian, and Tonkin.
- The 17<sup>th</sup> Proposed Rejection: Claim 18 is alleged as Obvious Under 35 U.S.C. § 103(a) in View of the Combination of Jurgén, Saturn '452, Davidian, and Tonkin.
- The 18<sup>th</sup> Proposed Rejection: Claims 24 and 25 are alleged as Obvious Under 35 U.S.C. § 103(a) in View of the Combination of Jurgén, Saturn '452, Davidian and Chasteen.
- The 19<sup>th</sup> Proposed Rejection: Claims 24, 25, and 27 are alleged as Obvious Under 35 U.S.C. § 103(a) in View of the Combination of Jurgén, Toyota '599, Davidian and Chasteen.
- The 20<sup>th</sup> Proposed Rejection: Claims 24, 25, and 27 are alleged as Obvious Under 35 U.S.C. § 103(a) in View of the Combination of Jurgén, Volkswagen '070, Davidian and Chasteen.
- The 21<sup>st</sup> Proposed Rejection: Claim 32 is alleged as Obvious Under 35 U.S.C. § 103(a) in in View of the combination of Davidian and Tonkin.

**Analysis of Substantial New Question of Patentability**

A SNQ of patentability is raised by a cited patent or printed publication when there is a substantial likelihood that a reasonable examiner would consider the prior art patent or printed publication important in deciding whether or not the claim is patentable. A SNQ of patentability is not raised by prior art presented in a reexamination request if the Office has previously considered (in an earlier examination of the patent) the same question of patentability as to a patent claim favorable to the patent owner based on the same prior art patents or printed publications. In re Recreative Technologies, 83 F.3d 1394, 38 USPQ2d 1776 (Fed. Cir. 1996). The substantial new question of patentability may be based on art previously considered by the Office if the reference is presented in a new light or a different way that escaped review during earlier examination. MPEP §2216.

It is not sufficient that a request for reexamination merely proposes one or more rejections of a patent claim or claims as a basis for reexamination. It must first be demonstrated that a patent or printed publication that is relied upon in a proposed rejection presents a new, non-cumulative technological teaching that was not previously considered and discussed on the record during the prosecution of the application that resulted in the patent for which reexamination is requested, and during the prosecution of any other prior proceeding involving the patent for which reexamination is requested. MPEP §2216.

**Basis of SNQ**

The '781 Patent was issued on September 21, 1999 from the '270 Application, filed on March 10, 1997. The previous Examiner of the '270 Application concluded the reasons for allowance for claims 1, 2, 4, 5, 7, 8, 10, 12, 13, 15, and 17 – 27 was the prior art failed to teach

or suggest upshift or downshift notification circuits. Therefore the limitations that are the basis of the SNQ of patentability affecting independent claims 1, 7, 13, 17, 23, 26, and their dependent claims 2, 4, 5, 8, 10, 12, 15, 18 – 22, 24, 25 and 27, teaches the upshift or downshift and reads as follows:

“an upshift notification circuit coupled to said processor subsystem, said upshift notification circuit issuing a notification that said engine of said vehicle is being operated at an excessive speed.”

OR

“a downshift notification circuit coupled to said processor subsystem, said downshift notification circuit issuing a notification that said engine of said vehicle is being operated at an insufficient engine speed.”

With respect to claims 28 - 30, the applicant in the original prosecution emphasized that the prior art failed to teach a fuel overinjection notification circuit that is activated based on three sensors: a road speed sensor, a throttle position sensor, and a manifold pressure sensor. Therefore the limitation disclosed in independent claim 28 which is the basis of the SNQ of patentability, and also affecting dependent claims 29 and 30, reads as follows:

“said fuel overinjection notification circuit issuing a notification that excessive fuel is being supplied to said engine of said vehicle.;said processor subsystem determining whether to activate said fuel overinjection notification sensor based upon data received from said road speed sensor, said throttle position sensor and said manifold pressure sensor.”

With respect to claims 31 and 32, the applicant in the original prosecution emphasized that the prior art failed to teach a vehicle proximity alarm that is activated based upon three parameters: (1) road speed, as determined by a road speed sensor; (2) separation, as determined by a radar detector; and (3) a vehicle speed/stopping distance table stored in a memory subsystem. The prosecution history focused on a vehicle proximity alarm that is activated based on these three parameters and was the basis for the reasons for allowance on these claims. Therefore the limitation disclosed in independent claim 31 which is the basis of the SNQ of patentability, also affecting dependent claim 32, reads as follows:

“said processor subsystem determining whether to activate said vehicle proximity alarm circuit based upon separation distance data received from said radar detector, vehicle speed data received from said road speed sensor and said first vehicle speed/stopping distance table stored in said memory subsystem.”

**Alleged SNQ based upon Jurgen**

Jurgen is presented to determine if a SNQ of patentability regarding Independent claims 1, 7, 13, 17, 23, 26, 28 of the '781 Patent is raised as stated in the First to Ninth proposed rejections, see above. Jurgen was not present as prior art in prior prosecutions of the application which became the '781 Patent.

Jurgen discloses an electronic engine control system that receives sensor inputs, evaluates them, and determines the necessary outputs to provide for optimal drivability.

(Jurgen, page 12.1). Jurgen also discloses that these sensors monitor engine speed (page 7.6), road speed (pages 7.8, 14.3), manifold pressure (pages 2.5, 2.7), and throttle position (page 12.21). Jurgen also discloses that the use of processor subsystems to receive inputs from these sensors was known. (Pages 12.1, 13.6, 22.6). "During the entire operating time of the vehicle, the ECUs are constantly supervising the sensors they are connected to." (Page 22.6). Jurgen illustrates these hardware parts:

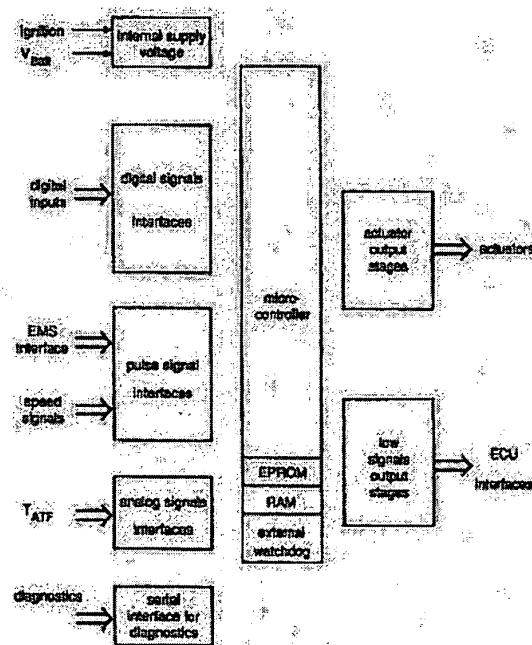

FIGURE 13.1 Overview of hardware parts.

Jurgen also discloses that the transmission can be controlled by calculating the necessary shift points based upon throttle position, the accelerator pedal position (e.g., throttle position), and the vehicle speed. "In the event that the particular shift characteristic is crossed (excessive/insufficient) by one of either of the two input valves, the electronic ECU releases the shift by



activating the related actuator. This can be a direct shift into the target gear or by a serial activation of specific actuators in a fixed sequence to the target gear, depending on the transmission hardware design." (Page 13.9). "The shift point limitations are made, on the one hand, by the highest admissible engine speed for each application." *Id.* The TCU (transmission control unit) stores shift maps that provide notifications to the transmission regarding whether and when to shift. (Page 13.14). Jorgen, therefore, discloses "an upshift[/downshift] notification circuit coupled to said processor subsystem, said upshift[/downshift] notification circuit issuing a notification that said engine of said vehicle is being operated at an excessive[/insufficient] speed" as taught in Independent claims 1, 7, 13, 17, 23, and 26.

Accordingly, these teachings would be important to a reasonable examiner in deciding patentability as to at least Independent claims 1, 7, 13, 17, 23, and 26 of the '781 Patent. Further, Jorgen teachings are new and non-cumulative. Accordingly, Jorgen raises a substantial new question of patentability as to at least independent claims 1, 7, 13, 17, 23, and 26 of the '781 Patent that have not been decided in a previous examination. Dependent claims 2, 4, 5, 8, 10, 12, 15, 18 – 22, 24, 25, and 27 are brought in at least due to their dependency on Independent claims 1, 7, 13, 17, 23, and 26.

Jorgen discloses fuel injection notification circuit, which issues a notification to shut off fuel in certain situations. For Example, the ECU disclosed in Jorgen can shut of fuel in certain situation by evaluating the throttle position, engine RPM, and vehicle speed. (Page 12.4). Additionally, the ECU can shut off fuel injectors when a maximum speed is achieved (page 12.14). The ECU provides a notification to the fuel injectors when a fuel cutoff state is reached.

Jurgen discloses based upon data received from said plurality of sensors, when to activate said fuel injection circuit and when to activate said upshift/downshift notification circuit. For example, the combination of the ECU, which monitors all of the vehicle's sensors (see above) and the TCU, which stores the shift maps, can send notification circuits to the fuel injectors and/or the transmission in order to alleviate a fuel overinjection condition or shift the engine.

Accordingly, Jurgen teachings, either alone or in combination with a secondary reference, would be important to a reasonable examiner in deciding patentability as to at least Independent claim 28 of the '781 Patent. Further, Jurgen teachings are new and non-cumulative.

Accordingly, Jurgen raises a substantial new question of patentability as to at least independent claim 28 of the '781 Patent that have not been decided in a previous examination. Dependent claims 29 and 30 are brought in at least due to their dependency on Independent claim 28.

#### **Alleged SNQ based upon Saturn '452**

Saturn '452 Patent is presented to determine if a SNQ of patentability regarding Independent claims 1, 13, 17, 23, and 26 of the '781 Patent is raised as stated in the First and Sixth proposed rejection, see above. Saturn '452 was not present as prior art in prior prosecutions of the application which became the '781 Patent.

Saturn '452 discloses an upshift notification circuit connected to the control unit, which indicates "via line 60 the state of an upshift indicator light or equivalent visual display." Col. 2, lines 42 to 55. Therefore, it is seen that Saturn '452 discloses "an upshift notification circuit coupled to said processor subsystem, said upshift notification circuit issuing a notification that said engine of said vehicle is being operated at an excessive speed" and "said processor

subsystem determining, based upon data received from said plurality of sensors, . . . when to activate said upshift notification circuit." as taught in Independent claims 1, 17, and 23.

Accordingly, these teachings would be important to a reasonable examiner in deciding patentability as to at least Independent claims 1, 17, and 23 of the '781 Patent. Further, Saturn '452 teachings are new and non-cumulative. Accordingly, Saturn '452 raises a substantial new question of patentability as to at least independent claims 1, 17, and 23 of the '781 Patent that have not been decided in a previous examination. Dependent claims 2, 4, 5, 18 – 22, 24, and 25 are brought in at least due to their dependency on Independent claims 1, 17, and 23.

**Alleged SNQ based upon Toyota '599**

Toyota '599 is presented to determine if a SNQ of patentability regarding Independent claims 1, 7, 13, 17, 23, and 26 of the '781 Patent is raised as stated in the Second and Forth proposed rejections, see above. Toyota '599 was not present as prior art in prior prosecutions of the application which became the '781 Patent.

Toyota '599 discloses a "shift indication apparatus coupled to a plurality of sensors. An overview of this system is illustrated in Figure 1:

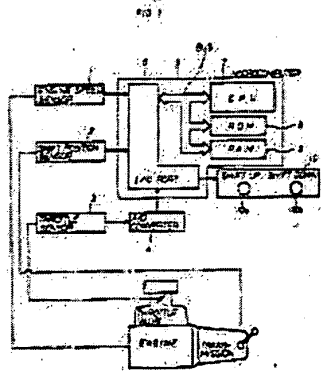

Toyota '599 discloses that indicator lamps that tell the driver to shift up or shift down are lit by the microcomputer in order to tell the driver when to shift to improve fuel economy "Namely, in this step, the speed change operation indicating signal is applied to the indicator or display 10 from the microcomputer 5 through the I/O port 6. As a result, a particular lamp in this case, a shift up indicating lamp in the indicator 10, is illuminated, thus indicating to the drive that the speed change from current shift position to the one step shifting up position  $SP_{+1}$  is preferable." Col. 5, line 63 to col. 6, line 2. "However, only when either one of the assumed fuel consumption rates above is better than the current fuel consumption rate  $B_c$ , the corresponding shift-up lamp or shift-down lamp in the indicator 10 is illuminated, thus indicating the necessity of the speed change operation." E.g. col. 7, lines 29 to 38. Therefore, Toyota '599 discloses "an upshift[/downshift] notification circuit coupled to said processor subsystem, said upshift[/downshift] notification circuit issuing a notification that said engine of said vehicle is being operated at an excessive[/insufficient] speed" and "said processor subsystem determining, based upon data received from said plurality of sensors,.. when to activate said upshift[/downshift] notification circuit."

Accordingly, these teachings would be important to a reasonable examiner in deciding patentability as to at least Independent claims 1, 7, 13, 17, 23, and 26 of the '781 Patent. Further, Toyota '599 teachings are new and non-cumulative. Accordingly, Toyota '599 raises a substantial new question of patentability as to at least independent claims 1, 7, 13, 17, 23, and 26 of the '781 Patent that have not been decided in a previous examination. Dependent claims 2, 4,

5, 8, 10, 12, 15, 18 – 22, 24, 25, and 27 are brought in at least due to their dependency on Independent claims 1, 7, 13, 17, 23, and 26.

### Alleged SNQ based upon Volkswagen '070

Volkswagen '070 is presented to determine if a SNQ of patentability regarding Independent claims 1, 7, 13, 17, 23, and 26 of the '781 Patent is raised as stated in the Third and Fifth proposed rejections, see above. Volkswagen '070 was not present as prior art in prior prosecutions of the application which became the '781 Patent.

Volkswagen '070 discloses:

Volkswagen '070 discloses a device "that assists the operator of [an] internal combustion engine equipped with a conventional transmission." Page 5. The device receives an engine speed signal "with the aid of known sensor systems" and uses it to activate an "engine-speed dependent change-over switch 6." Page 7. Volkswagen '070 describes two operating ranges, I and II, and the change-over switch 6 indicates that an upshift or downshift is necessary when the limits of those ranges (e.g., the RPM set point) is reached. Pages 6–8. For example, Figure 2 of Volkswagen '070 illustrates the change-over switch, which receives the engine speed signal and determines when to activate the upshift and downshift notification lamps 4 and 6:

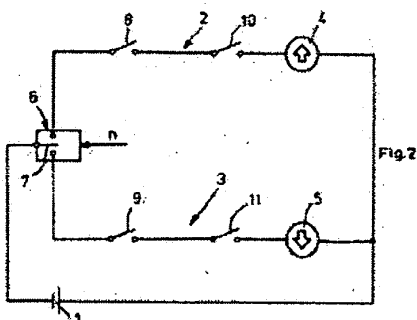

Accordingly, these teachings would be important to a reasonable examiner in deciding patentability as to at least Independent claims 1, 7, 13, 17, 23, and 26 of the '781 Patent. Further, Volkswagen '070 teachings are new and non-cumulative. Accordingly, Volkswagen '070 raises

a substantial new question of patentability as to at least independent claims 1, 7, 13, 17, 23, and 26 of the '781 Patent that have not been decided in a previous examination.

**Alleged SNQ based upon Davidian**

Davidian is presented to determine if a SNQ of patentability regarding claims 17, 23, 26, and 31 of the '781 Patent is raised as stated in the Fourth, Fifth, Sixth and Tenth proposed rejection, see above. Davidian was not present as prior art in prior prosecutions of the application which became the '781 Patent.

Davidian discloses a memory subsystem that stores a vehicle speed/stopping distance table. *"Computer module 90 also includes information about the vehicle braking distances as a function of speed. This is preferably in the form of a look-up table, for example, provided by the manufacturer for predetermined defined conditions concerning road type, skidding danger, vehicle load and tires pressure, and is stored in a ROM (read-only memory) of the microcomputer so that it can be changed periodically if necessary."* Col. 9, lines 20 to 27. This memory subsystem is a part of the microcomputer 4, as illustrated in FIG. 6A. Therefore, Davidian discloses "a memory subsystem, coupled to said processor subsystem, said memory subsystem storing a first vehicle speed/stopping distance table." Davidian discloses a vehicle proximity alarm circuit, which activates a collision alarm when a calculated "Collision Distance" is close to a calculated "Stopping Distance." "A determination is also made of the collision distance CD which is equal to the stopping distance SD divided by the collision safety factor CSF, e.g., 1.25 in the example illustrated above, such that should the distance between the vehicle and the object come within the collision distance CD, the collision alarm is then

actuated." Col. 12, line 59 to col. 13, line 11. The collision alarm, may be an audio alarm or a visual alarm. Col. 9, lines 52 to 56. The determination whether to activate the collision alarm is made by the calculation module 90, which is part of the microcomputer 4. *See* col. 12, line 27 ("Operation of the Calculation Module 90"). Therefore, Davidian discloses "a vehicle proximity alarm circuit coupled to said processor subsystem, said vehicle proximity alarm circuit issuing an alarm that said vehicle is too close to said object." Davidian also discloses that the processor subsystem determines when to activate the proximity alarm based on (1) separation distance data (received from the front vehicle space sensor 8); (2) vehicle speed data (received from vehicle speed sensor 12); and (3) the vehicle speed/stopping distance table stored in memory. The radar input, the vehicle speed input, and the vehicle speed/stopping distance tables are all located in the calculation module 90, which it uses to calculate stopping distance and collision distance. Therefore, Davidian discloses "said processor subsystem determining whether to activate said vehicle proximity alarm circuit based upon separation distance data received from said radar detector, vehicle speed data received from said road speed sensor and said first vehicle speed/stopping distance table stored in said memory subsystem."

Accordingly, these teachings would be important to a reasonable examiner in deciding patentability as to at least Independent claim 31 of the '781 Patent. Further, Davidian teachings are new and non-cumulative. Accordingly, Davidian raises a substantial new question of patentability as to at least independent claim 31 of the '781 Patent that have not been decided in a previous examination. Dependent claim 32 is brought in at least due to their dependency on Independent claim 31.

Davidian does not disclose “an upshift notification circuit coupled to said processor subsystem, said upshift notification circuit issuing a notification that said engine of said vehicle is being operated at an excessive speed,” OR “a downshift notification circuit coupled to said processor subsystem, said downshift notification circuit issuing a notification that said engine of said vehicle is being operated at an insufficient engine speed.” Davidian teachings alone would not be pertinent to a reasonable examiner in deciding patentability as to at least Independent claims 1, 17, 23, and 26 of the ‘781 Patent. Accordingly, Davidian does not raises a substantial new question of patentability as to independent claims 1, 17, 23, and 26 of the ‘781 Patent.

**Alleged SNQ based upon Nissan ‘055**

Nissan ‘055 is presented to determine if a SNQ of patentability regarding Independent claim 28 of the ‘781 Patent is raised as stated in the Seventh proposed rejection, see above. Nissan ‘055 was not present as prior art in prior prosecutions of the application which became the ‘781 Patent.

Nissan ‘055 discloses a control system that "controls the number of fuel injected cylinders" in order to increase fuel economy. Abstract. Figure 1 of Nissan '055 discloses that a throttle opening sensor and vehicle velocity sensor are inputs to the system:



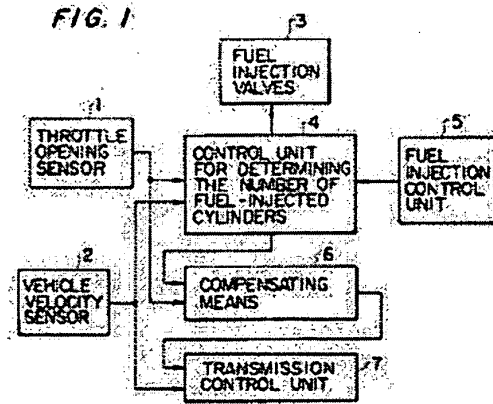

Nissan '055 discloses that "when the signal from the vehicle velocity sensor 2 exceeds a predetermined level and at the same time the signal from the throttle opening sensor 1 falls below another predetermined level, the control unit 4 determines the number of cylinders to which fuel is actually injected based on the two signals applied and stops injection of fuel to specified one or more cylinders." Col. 2, lines 59 to 66. Nissan '055 does not refer to the use of a manifold pressure sensor.

Nissan '055 does not disclose "said processor subsystem determining whether to activate said fuel overinjection notification sensor based upon data received from said road speed sensor, said throttle position sensor and said manifold pressure sensor" since Nissan '055 does not take into consideration the manifold pressure in their determination.

Nissan '055 teachings alone would not be pertinent to a reasonable examiner in deciding patentability as to at least Independent claim 28 of the '781 Patent. Accordingly, Nissan '055 alone does not raise a substantial new question of patentability as to independent claim 28 of the '781 Patent.

**Alleged SNQ based upon Mack '324**

Mack '324 is presented to determine if a SNQ of patentability regarding Independent claim 28 of the '781 Patent is raised as stated in the Eighth proposed rejection, see above. Mack '324 was not present as prior art in prior prosecutions of the application which became the '781 Patent.

Mack '324 discloses an engine and vehicle management and control system. Figure 1 of Mack '324 illustrates an overview of the system:

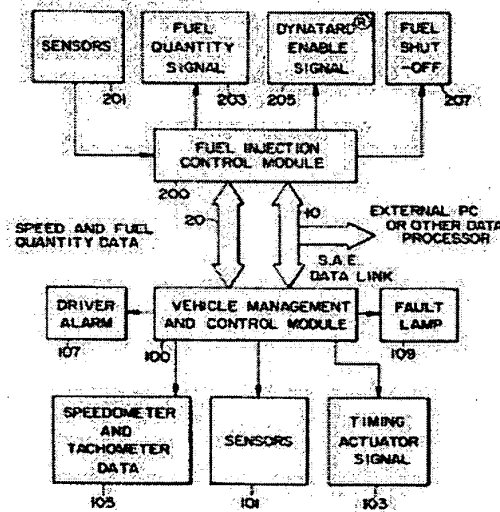

The fuel injection control module 200 in Mack '324 contains a microprocessor 2001, and receives inputs from sensors 201 and outputs a fuel quantity signal 203 and a fuel shut-off enable signal 207. Col. 2, lines 33 to 27. Figure 3 illustrates the details of the fuel injection control module:

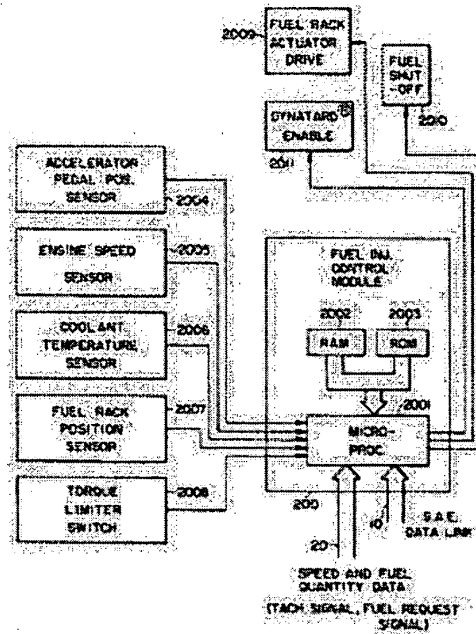

Inputs to the fuel injection control module include sensor inputs from "an accelerator pedal position sensor 2005, an engine speed sensor 2005, a coolant temperature sensor 2006, a fuel rack position sensor 2007, and a torque limiter switch 2008." Col. 3, lines 57 to 61. Mack '324 discloses a fuel injection signal that stops fuel being injected to the engine when certain overspeed conditions are met. Col. 6, lines 24 to 53. The fuel request signal is sent by the fuel injection control module, to which the sensors are input. However, Mack '324 does not refer to the use of a manifold pressure sensor. Therefore, Mack '324 does not disclose "said processor subsystem determining whether to activate said fuel overinjection notification sensor based upon data received from said road speed sensor, said throttle position sensor and said manifold pressure sensor," since Mack '324 does not need a manifold pressure sensor in their

determination as to how much fuel is sent to the engine and said system prevents too much fuel from being injected into the system.

Accordingly, Mack '324 teachings alone would not be important to a reasonable examiner in deciding patentability as to at least Independent claim 28 of the '781 Patent. Mack '324 teachings are new and non-cumulative. Accordingly, Mack '324 alone does not raise a substantial new question of patentability as to independent claim 28 of the '781 Patent.

**Alleged SNQ based upon GM '753**

GM '753 is presented to determine if a SNQ of patentability regarding Independent claim 28 of the '781 Patent is raised as stated in the Ninth proposed rejection, see above. GM '753 was not present as prior art in prior prosecutions of the application which became the '781 Patent.

GM '753 discloses a "warning system for providing an indication when the fuel consumption of a throttle controlled vehicle having an internal combustion engine with an intake manifold exceeds pre-established levels." The vacuum transducer 12 of GM '753 "is effective to generate a voltage having a magnitude which progressively changes with a progressively increased manifold intake level." Col. 1, lines 38 to 55. The speed transducer "generates a series of voltage pulses having a frequency progressively increasing with increasing vehicle speed." Col. 2, lines 34 to 51. These inputs are fed to an analog circuit, which is used to send current to a lamp when a level "determined to represent excessive fuel consumption" is reached. Col. 2, lines 52 to 58. "When the vehicle is operated in a manner such that the manifold vacuum decreases below the manifold vacuum trigger level established at the instantaneous vehicle speed, *the output of the summing switch 14 swings positive to effect energization of the lamp 30 to provide*

*an indication of fuel consumption in excess of the predetermined amount at that speed."* Col. 3, lines 20 to 27. GM '753 does not refer to the use of a throttle position sensor, nor any other specific sensor in their system. There is also no processor in which the information is determined as to whether or not to activate said fuel overinjection notification sensor. Therefore, GM '753 does not disclose "said processor subsystem determining whether to activate said fuel overinjection notification sensor based upon data received from said road speed sensor, said throttle position sensor and said manifold pressure sensor."

Accordingly, these teachings alone would not be important to a reasonable examiner in deciding patentability as to at least Independent claim 28 of the '781 Patent. GM '753 teachings are new and non-cumulative. Accordingly, GM '753 alone does not raise a substantial new question of patentability as to independent claim 28 of the '781 Patent.

#### **Alleged SNQ based upon Tonkin**

Tonkin is presented to determine if a SNQ of patentability regarding Independent claim 31 of the '781 Patent is raised as stated in the Eleventh proposed rejection, see above. Tonkin was not present as prior art in prior prosecutions of the application which became the '781 Patent.

Tonkin discloses a system that calculates a safety envelope and displays a visible warning when a rear-facing vehicle is getting too near. Abstract. Tonkin discloses the use of a radar sensor in order to determine "distance of separation and/or a relative velocity of a trailing vehicle." Page 1, lines 23 - 29. *See also* page 5, lines 4 - 9, "The sensor means for sensing the distance and velocity of the trailing vehicle may comprise a radar system." Tonkin also discloses

Art Unit: 3992

the use of sensors, including a velocity sensing means comprising "a conventional speed sensing device fitted to the vehicle's transmission train." Page 5, lines 17 - 19. Tonkin discloses the use of a memory subsystem that stores parameters in a lookup table, including a vehicle speed/stopping distance table. For example, Tonkin discloses that predetermined driving parameters "may for example be stored in a look up table." Page 3, lines 25 - 32. Additionally, the control system that activates the vehicle proximity alarm relies in part on "known safe stopping distances such as those published by the Minister of Transport, in which a vehicle will stop when the brakes are applied." Page 16, lines 2 - 21. Finally, Tonkin discloses that a look-up table or database could be provided for unsafe closing speeds, which could be varied according to the velocity of the subject vehicle." Page 17, lines 7 - 25. Tonkin discloses that the processor subsystem determines when to activate the proximity alarm circuit based upon (1) separation distance data received from said radar detector; (2) vehicle speed data received from said road speed sensor; and (3) the vehicle speed/stopping distance table. For example, the radar system is "operable to sense a distance of separation and/or a relative velocity of a trailing vehicle." Page 1, lines 32 - 34. The processor subsystem "is operable to process the received velocity signal and data signals to determine the existence of an unsafe condition." The velocity signal used by the processing means is the vehicle velocity signal determined from the vehicle speed sensor. Page 5, lines 17 - 19. The data signals include the separation data (determined from the radar), and the determination regarding whether to activate the alarm is made, in part, using the safe stopping distances provided in the look-up table. Page 17, lines 7 to 25. Therefore, Tonkin discloses "said processor subsystem determining whether to activate said vehicle proximity alarm circuit based upon separation distance data received from said radar detector, vehicle speed data received from

Art Unit: 3992

said road speed sensor and said first vehicle speed/stopping distance table stored in said memory subsystem."

Accordingly, these teachings would be important to a reasonable examiner in deciding patentability as to at least Independent claim 31 of the '781 Patent. Further, Tonkin teachings are new and non-cumulative. Accordingly, Tonkin raises a substantial new question of patentability as to at least independent claim 31 of the '781 Patent that have not been decided in a previous examination. Dependent claim 32 is brought in at least due to their dependency on Independent claim 31.

#### **Alleged SNQ based upon Doi**

Doi is presented to determine if a SNQ of patentability regarding Independent claim 31 of the '781 Patent is raised as stated in the Eleventh proposed rejection, see above. Doi was present as prior art in prior prosecutions of the application which became the '781 Patent.

In an amendment from the Applicant, dated February 8, 1999, the Applicant asserted that claim 31, previously claim 37 in the '270 Application:

The Applicants respectfully submit that new Claims 37-38, as presented herein, are neither taught nor suggested by the proposed combination of Chasteen and Doi et al. The Examiner properly cited Doi et al. as disclosing a vehicle running mode detection system equipped with a radar detector and an alarm circuit. The Applicants respectfully note, however, that the system disclosed in Doi et al. determines alert conditions relative to the proximity between a vehicle and a forward object based upon changes in the distance separating the vehicle and the forward object. In contrast, Applicants' apparatus for optimizing vehicle operation set forth in Claim 37 includes a processor subsystem configured to activate a vehicle proximity alarm circuit based upon road speed (as determined by a road speed sensor), separation (as determined by a radar detector) and a vehicle speed/stopping distance table stored in a memory subsystem.

Also see, The Request pp. 11-14 for more details.

The Examiner of the '270 Application subsequently issued a Notice of Allowance stating that the prior art did not teach the limitation in question, which is the basis for the SNQ of claim 31. It is further seen in the Request, pages 80 – 83, that the Requester utilizes Doi in the same way as what was already discussed by the Applicant and agreed to by the Examiner of the '270 Application in their reasons for allowance, i.e., Doi does not disclose the limitation that is the basis for SNQ for claim 31. Doi is not new prior art and also not used or presented in a new light that would raise a SNQ for claim 31. Therefore, it is seen that Doi alone does not disclose a vehicle proximity alarm that is activated based upon three parameters: (1) road speed, as determined by a road speed sensor; (2) separation, as determined by a radar detector; and (3) a vehicle speed/stopping distance table stored in a memory subsystem.

Accordingly, these teachings would **not** be important to a reasonable examiner in deciding patentability as to at least Independent claim 31 of the '781 Patent. Accordingly, Doi alone does not raise a substantial new question of patentability as to independent claim 31 of the '781 Patent.

### ***Conclusion***

A Request for *ex parte* reexamination of United States Patent Number 5,954,781 is Ordered.

A substantial new question of patentability affecting claims 1, 2, 4, 5, 7, 8, 10, 12, 13, 15, and 17 – 30 of United States Patent Number 5,954,781 is raised by the Request for *ex parte*



reexamination based on the Jurgen, Saturn '452, Toyota '599, and Volkswagen '070 cited areas supplied by the Requester.

A substantial new question of patentability affecting claims 31 and 32 of United States Patent Number 5,954,781 is raised by the Request for *ex parte* reexamination based on the Davidian, and Tonkin cited areas supplied by the Requester.

Therefore, claims 1, 2, 4, 5, 7, 8, 10, 12, 13, 15, and 17 – 32 will be reexamined.

Nissan '055, Mack '324, and GM '753 alone do **Not** raise a SNQ affecting claims 28 – 30.

Davidian alone does **Not** raise a SNQ affecting claims 1, 2, 4, 5, 7, 8, 10, 12, 13, 15, and 17 – 27.

Doi alone does **Not** raise a SNQ affecting claims 31 and 32.

Extensions of time under 37 CFR 1.136(a) will not be permitted in these proceedings because the provisions of 37 CFR 1.136 apply only to "an applicant" and not to parties in a reexamination proceeding. Additionally, 35 U.S.C. 305 requires that *ex parte* reexamination proceedings "will be conducted with special dispatch" (37 CFR 1.550(a)). Extensions of time in *ex parte* reexamination proceedings are provided for in 37 CFR 1.550(c).

#### **Notification of Concurrent Proceedings**

The patent owner is reminded of the continuing responsibility under 37 CFR 1.985 to apprise the Office of any litigation activity, or other prior or concurrent proceeding, involving the '469 Patent throughout the course of this reexamination proceeding. The third party requester is

also reminded of the ability to similarly apprise the Office of any such activity or proceeding throughout the course of this reexamination proceeding. See MPEP §§ 2207, 2282 and 2286.

### CORRESPONDENCE

All correspondence relating to this ex parte reexamination proceeding should be directed:

By EFS: Registered users may submit via the electronic filing system EFS-Web, at <https://sportal.uspto.gov/authenticate/authenticateuserlocalepf.html>.

By Mail to: Mail Stop *Ex Parte* Reexam  
Central Reexamination Unit  
Commissioner for Patents  
United States Patent & Trademark Office  
P.O. Box 1450  
Alexandria, VA 22313-1450

By FAX to: (571) 273-9900  
Central Reexamination Unit

By hand: Customer Service Window  
Randolph Building  
401 Dulany Street  
Alexandria, VA 22314

For EFS-Web transmissions, 37 CFR 1.8(a)(1)(i) (C) and (ii) states that correspondence (except for a request for reexamination and a corrected or replacement request for reexamination) will be considered timely filed if (a) it is transmitted via the Office's electronic filing system in accordance with 37 CFR 1.6(a)(4), and (b) includes a certificate of transmission for each piece of correspondence stating the date of transmission, which is prior to the expiration of the set period of time in the Office action.

Application/Control Number: 90/013,252  
Art Unit: 3992

Page 31

Any inquiry concerning this communication or earlier communications from the Examiner, or as to the status of this proceeding, should be directed to the Central Reexamination Unit at telephone number (571) 272-7705.

Signed:

/David E. England/  
Primary Examiner, Art Unit 3992

Conferees:

/Michael J. Yigdall/  
Primary Examiner, Art Unit 3992

/Fred Ferris/  
Acting SPRS CRU

Receipt date: 05/22/2014

	PATENT NO. 5,954,781	PATENTEE Harvey SLEPIAN et al.
	PATENT DATE September 21, 1999	

**U. S. PATENT DOCUMENTS**

EXAM. INITIAL	PATENT/ PUBLICATION NUMBER	NAME	PATENT/ PUBLICATION DATE	CLASS	SUBCLASS	FILING DATE
	4,901,701	Chasteen	February 20, 1990			
	4,631,515	Blee et al.	December 23, 1986			
	5,708,584	Doi et al.	January 13, 1998			
	5,477,452	Milunas et al.	December 19, 1995			
	4,559,599	Habu et al.	December 17, 1985			
	5,357,438	Davidian	October 18, 1994			
	4,061,055	Iizuka et al.	December 6, 1977			
	5,121,324	Rini et al.	June 9, 1992			

**FOREIGN PATENT DOCUMENTS**

EXAMINER INITIAL	DOCUMENT NUMBER	COUNTRY	DATE	NAME	SUBCLASS	TRANSLATION	
						YES	NO
	29 26 070*	DE	January 15, 1981			X	
	96/02853	WO	February 1, 1996				

\* - Certified English-language translation is provided.

**OTHER DOCUMENTS**

EXAMINER INITIAL	Name
	"First Amended Complaint for Patent Infringement" filed on January 30, 2014 in <i>VELOCITY PATENT LLC v. AUDI OF AMERICA, INC.</i> , Case No. 1:13-cv-08418-JGB (N.D. Ill.)
	Velocity Patent LLC's Initial Infringement Contentions Pursuant to Local Patent Rule 2.2 to Audi
	Velocity Patent LLC's Initial Infringement Contentions Pursuant to Local Patent Rule 2.2 to Mercedes-Benz
	Velocity Patent LLC's Initial Infringement Contentions Pursuant to Local Patent Rule 2.2 to Chrysler
	Velocity Patent LLC's Initial Infringement Contentions Pursuant to Local Patent Rule 2.2 to Jaguar Land Rover

EXAMINER /David England/	DATE CONSIDERED 06/20/2014
EXAMINER: Initial if citation considered, whether or not citation is in conformance with M.P.E.P. 609; draw line through citation if not in conformance and not considered. Include copy of this form with next communication to applicant.	

ALL REFERENCES CONSIDERED EXCEPT WHERE LINED THROUGH. /DE/

Receipt date: 05/22/2014

<b>LIST OF DOCUMENTS CITED BY THIRD PARTY REQUESTER IN EX PARTE REEXAMINATION</b>	PATENT NO. 5,954,781	PATENTEE Harvey SLEPIAN et al.
	PATENT DATE September 21, 1999	

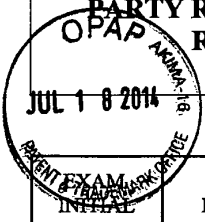

**U. S. PATENT DOCUMENTS**

PATENT/ PUBLICATION NUMBER	NAME	PATENT/ PUBLICATION DATE	CLASS	SUBCLASS	FILING DATE
3,925,753	Auman et al.	December 9, 1975			

**FOREIGN PATENT DOCUMENTS**

EXAMINER INITIAL	DOCUMENT NUMBER	COUNTRY	DATE	NAME	SUBCLASS	TRANSLATION	
						YES	NO

**OTHER DOCUMENTS**

EXAMINER INITIAL	Name
	"Automotive Electronics Handbook," pgs. 2.5-2.9, 3.16, 7.6-7.8, 7.21-7.26, 11.3-11.4, 11.24-11.31, 11.55, 12.1-12.36, 13.1-13.21, 14.1-14.9, and 22.1-22.20, published in 1995, by Ronald Jurgen
	Certified English-language translation of German Patent Application Publication No. 29 26 070

EXAMINER /David England/	DATE CONSIDERED 06/20/2014
EXAMINER: Initial if citation considered, whether or not citation is in conformance with M.P.E.P. 609; draw line through citation if not in conformance and not considered. Include copy of this form with next communication to applicant.	

ALL REFERENCES CONSIDERED EXCEPT WHERE LINED THROUGH. /DE/

POSTAGE WILL BE PAID BY ADDRESSEE

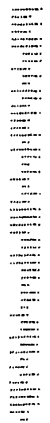

OFFICE

ALEXANDRIA, VA 22313-1450  
IF UNDELIVERABLE RETURN IN TEN DAYS

OFFICIAL BUSINESS  
Penalty for Private Use, \$300

**AN EQUAL OPPORTUNITY EMPLOYER**

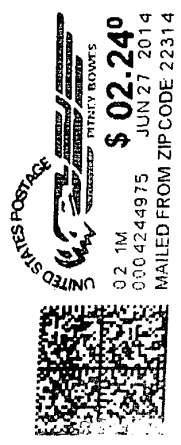

NIXIE 752023085-1N 07/05/14

RETURN TO SENDER  
UNABLE TO FORWARD  
UNABLE TO FORWARD  
RETURN TO SENDER

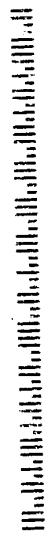

RECEIVED  
JUL 18 2014  
USPTO MAIL CENTER



UNITED STATES PATENT AND TRADEMARK OFFICE

UNITED STATES DEPARTMENT OF COMMERCE  
United States Patent and Trademark Office  
Address: COMMISSIONER FOR PATENTS  
P.O. Box 1450  
Alexandria, Virginia 22313-1450  
www.uspto.gov

APPLICATION NUMBER	FILING OR 371(C) DATE	FIRST NAMED APPLICANT	ATTY. DOCKET NO./TITLE
90/013,252	05/22/2014	5,954,781	

MICHAEL S. BUSH  
HAYNES AND BOONE LLP  
3100 NATIONSBANK PLAZA  
901 MAIN STREET  
DALLAS, TX 75202-3789

**CONFIRMATION NO. 9999**  
**POWER OF ATTORNEY NOTICE**



Date Mailed: 07/02/2014

**NOTICE REGARDING CHANGE OF POWER OF ATTORNEY**

This is in response to the Power of Attorney filed 06/27/2014.

- The Power of Attorney to you in this application has been revoked by the assignee who has intervned as provided by 37 CFR 3.71. Future correspondence will be mailed to the new address of record(37 CFR 1.33).

/jawhitfield/

Office of Data Management, Application Assistance Unit (571) 272-4000, or (571) 272-4200, or 1-888-786-0101



UNITED STATES PATENT AND TRADEMARK OFFICE

UNITED STATES DEPARTMENT OF COMMERCE  
United States Patent and Trademark Office  
Address: COMMISSIONER FOR PATENTS  
P.O. Box 1450  
Alexandria, Virginia 22313-1450  
www.uspto.gov

APPLICATION NUMBER	FILING OR 371(C) DATE	FIRST NAMED APPLICANT	ATTY. DOCKET NO./TITLE
90/013,252	05/22/2014	5,954,781	

88360  
Richards Patent Law P.C.  
233 S. Wacker Dr., 84th Floor  
Chicago, IL 60606

**CONFIRMATION NO. 9999**  
**POA ACCEPTANCE LETTER**



Date Mailed: 07/02/2014

**NOTICE OF ACCEPTANCE OF POWER OF ATTORNEY**

This is in response to the Power of Attorney filed 06/27/2014.

The Power of Attorney in this application is accepted. Correspondence in this application will be mailed to the above address as provided by 37 CFR 1.33.

/jawhitfield/

Office of Data Management, Application Assistance Unit (571) 272-4000, or (571) 272-4200, or 1-888-786-0101





UNITED STATES PATENT AND TRADEMARK OFFICE

UNITED STATES DEPARTMENT OF COMMERCE
United States Patent and Trademark Office
Address: COMMISSIONER FOR PATENTS
P.O. Box 1450
Alexandria, Virginia 22313-1450
www.uspto.gov

Table with 5 columns: APPLICATION NO., FILING DATE, FIRST NAMED INVENTOR, ATTORNEY DOCKET NO., CONFIRMATION NO.
90/013,252 05/22/2014 5,954,781 9999

MICHAEL S. BUSH
HAYNES AND BOONE LLP
3100 NATIONSBANK PLAZA
901 MAIN STREET
DALLAS, TX 75202-3789

EXAMINER

ENGLAND, DAVID E

ART UNIT PAPER NUMBER

3992

MAIL DATE DELIVERY MODE

06/27/2014

PAPER

Please find below and/or attached an Office communication concerning this application or proceeding.

The time period for reply, if any, is set in the attached communication.



**DO NOT USE IN PALM PRINTER**

(THIRD PARTY REQUESTER'S CORRESPONDENCE ADDRESS)

KENYON & KENYON LLP

ONE BROADWAY

NEW YORK, NY 10004

***EX PARTE* REEXAMINATION COMMUNICATION TRANSMITTAL FORM**

REEXAMINATION CONTROL NO. 90/013,252.

PATENT NO. 5,954,781.

ART UNIT 3992.

Enclosed is a copy of the latest communication from the United States Patent and Trademark Office in the above identified *ex parte* reexamination proceeding (37 CFR 1.550(f)).

Where this copy is supplied after the reply by requester, 37 CFR 1.535, or the time for filing a reply has passed, no submission on behalf of the *ex parte* reexamination requester will be acknowledged or considered (37 CFR 1.550(g)).

1. The present application is being examined under the pre-AIA first to invent provisions.

### **DECISION GRANTING EX PARTE REEXAMINATION**

A Request for *ex parte* reexamination affecting claims 1, 2, 4, 5, 7, 8, 10, 12, 13, 15 and 17 – 32 of United States Patent Number 5,954,781 (hereafter “the ‘781 Patent”) has been submitted on 05/22/2014.

Extensions of time under 37 CFR 1.136(a) will not be permitted in these proceedings because the provisions of 37 CFR 1.136 apply only to "an applicant" and not to parties in a reexamination proceeding. Additionally, 35 U.S.C. 305 requires that *ex parte* reexamination proceedings "will be conducted with special dispatch" (37 CFR 1.550(a)). Extensions of time in *ex parte* reexamination proceedings are provided for in 37 CFR 1.550(c).

### **Prosecution History**

The ‘781 Patent was issued on September 21 1999 from U.S. Application Serial No. 08/813,270, hereinafter “the ‘270 Application”, filed on March 10, 1997.

The prosecution history of the ‘781 Patent includes:

The '270 application was filed on March 10, 1997 with 32 claims, of which application claims 1, 14, 18, and 27 were the only independent claims. Among these independent claims, application claim 1 included a fuel overinjection circuit, application claim 14 included a fuel overinjection circuit, an upshift notification circuit, and a downshift notification circuit,

application claim 18 included a vehicle proximity alarm, and application claim 27 included a fuel overinjection circuit and a vehicle proximity alarm.

In the only Office Action, dated August 6, 1998, application claims 1, 2 and 4 to 6 were rejected as obvious in view of U.S. Patent No. 4,901,701 to Chasteen (copy attached as Exhibit 3), application claim 3 was rejected as obvious in view of the combination of Chasteen and U.S. Patent No. 4,631,515 to Blee et al. (copy attached as Exhibit 4), and application claims 7, 18 to 24, 27, and 28 were rejected as obvious in view of the combination of Chasteen and U.S. Patent No. 5,708,584 to Doi et al. (copy attached as Exhibit 5).

In the Office Action, the Examiner stated that application claims 8 to 13, 25, 26, and 29 to 32 included allowable subject matter. Specifically, the Examiner stated that application claims 8, 25, and 29 included allowable subject matter on the basis that "the prior art fails to disclose an upshift notification circuit coupled to the processor subsystem, the upshift notification circuit issuing a notification that the engine of the vehicle is being operated at an excessive engine speed and the processor determines when to activate the upshift notification circuit." Similarly, the Examiner stated that application claims 11, 26, and 31 included allowable subject matter on the basis that "the prior art fails to disclose a downshift notification circuit coupled to the processor subsystem, the downshift notification circuit issuing a notification that the engine of the vehicle is being operated at an insufficient engine speed and the processor determines when to activate the downshift notification circuit." In addition, application claims 14 - 17, which included both an upshift notification circuit and a downshift notification circuit, were allowed on the basis that:

the prior art fails to disclose an upshift notification circuit coupled to the processor subsystem, the upshift notification circuit issuing a notification that the engine of the vehicle is being operated at an excessive engine speed and the processor determines when to activate the upshift notification circuit and a downshift notification circuit coupled to the processor subsystem, the downshift notification circuit issuing a notification that the engine of the vehicle is being operated at an insufficient engine speed and the processor determines when to activate the downshift notification circuit.

In response to this Office Action, the applicant submitted an Amendment on February 8, 1999 with numerous amendments, see the response to Office Action and the Request pages 6 – 13 for further explanation. The '270 Application was subsequently allowed, see Notice of Allowance dated 04/21/1999 or the Request pages 13 and 14 for further details. The Examiner stated in their reasons for allowance that:

*The prior art fails to disclose an apparatus for optimizing operation of a vehicle and comprising an upshift notification circuit coupled to the processor subsystem, the upshift notification circuit issuing a notification that the engine of the vehicle is being operated at an excessive speed and the processor determines when to activate the upshift notification circuit; and a downshift notification circuit coupled to the processor subsystem, the downshift notification circuit issuing*

a notification that the engine of the vehicle is being operated at an insufficient engine speed and the processor determines when to activate the downshift notification circuit.

The Notice of Allowance further states that:

Nor does the prior art disclose [sic] a fuel overinjection notification circuit coupled to the processor subsystem, wherein the fuel overinjection notification circuit issuing a notification that excess fuel is being supplied to the engine of the vehicle and the processor subsystem determining whether to activate the fuel overinjection notification circuit based upon data received from the road speed sensor, the throttle position sensor and the manifold sensor.

Additionally, the Notice of Allowance states:

Nor does the prior art disclose [sic] that the processor subsystem determines whether to activate the vehicle proximity alarm circuit based upon separation distance data received from the radar detector, vehicle speed/stopping distance table stored in the memory subsystem.

### **Proposed Substantial New Question of Patentability**

Third Party Requester (“Requester”) identifies the following printed publications as evidence that a substantial new question should be raised in the Request, see pp. 15-16.

1. Automotive Electronics Handbook, by Ronald Jurgen (“Jurgen”), attached as exhibit 11.
2. U.S. Patent No. 5,477,452 to Milunas et al. (“Saturn ‘452”), attached as exhibit 12.
3. U.S. Patent No. 4,559,599 to Habu et al. (“Toyota ‘599”), attached as exhibit 13.
4. German Patent Application Publication No. 29 26 070 (“Volkswagen ‘070”), attached as exhibit 14.
5. U.S. Patent No. 5,357,438 to Davidian (“Davidian”), attached as exhibit 15.

6. U.S. Patent No. 4,061,055 to Iizuka et al. ("Nissan '055"), attached as exhibit 16.
7. U.S. Patent No. 5,121,324 to Rini et al. ("Mack '324"), attached as exhibit 17.
8. U.S. Patent No. 3,925,753 to Auman et al. ("GM '452"), attached as exhibit 18.
9. PCT Publication No. WO 96/02853 ("Tonkin"), attached as exhibit 19.

Requester has alleged a substantial new question, "SNQ", of patentability in light of proposed rejections which are stated below:

- The 1<sup>st</sup> Proposed Rejection: Claim 1 is alleged as Obvious Under 35 U.S.C. § 103(a) in View of the Combination of Jurgan and Saturn '452.
- The 2<sup>nd</sup> Proposed Rejection: Claims 1, 7, and 13 are alleged as Obvious Under 35 U.S.C. § 103(a) in View of the Combination of Jurgan and Toyota '599.
- The 3<sup>rd</sup> Proposed Rejection: Claims 1, 7, and 13 are alleged as Obvious Under 35 U.S.C. § 103(a) in View of the Combination of Jurgan and Volkswagen '070.
- The 4<sup>th</sup> Proposed Rejection: Claims 17-23 and 26 are alleged as Obvious Under 35 U.S.C. § 103(a) in View of the Combination of Jurgan, Toyota '599, and Davidian.
- The 5<sup>th</sup> Proposed Rejection: Claims 17-23 and 26 are alleged as Obvious Under 35 U.S.C. § 103(a) in View of the Combination of Jurgan, Volkswagen '070, and Davidian.
- The 6<sup>th</sup> Proposed Rejection: Claims 17-21 and 23 are alleged as Obvious Under 35 U.S.C. § 103(a) in View of the Combination of Jurgan, Saturn '452, and Davidian.

- The 7<sup>th</sup> Proposed Rejection: Claims 28-30 are alleged as Obvious Under 35 U.S.C. § 103(a) in View of the Combination of Jurgen and Nissan '055.
- The 8<sup>th</sup> Proposed Rejection: Claims 28-30 are alleged as Obvious Under 35 U.S.C. § 103(a) in View of the Combination of Jurgen and Mack '324.
- The 9<sup>th</sup> Proposed Rejection: Claims 28-30 are alleged as Obvious Under 35 U.S.C. § 103(a) in View of the Combination of Jurgen and GM '753.
- The 10<sup>th</sup> Proposed Rejection: Claim 31 is alleged as Anticipated Under 35 U.S.C. § 102(b) by Davidian.
- The 11<sup>th</sup> Proposed Rejection: Claims 31 and 32 are alleged as Obvious Under 35 U.S.C. § 103(a) in View of the Combination of Tonkin and Doi et al.

Requester has proposed rejections for dependent claims that are not the basis for the SNQ, which are stated below:

- The 12<sup>th</sup> Proposed Rejection: Claims 2, 4, and 5 are alleged as Obvious Under 35 U.S.C. § 103(a) in View of the Combination of Jurgen, Saturn '452, and Chasteen.
- The 13<sup>th</sup> Proposed Rejection: Claims 2, 4, 5, 8, 10, 12, and 15 are alleged as Obvious Under 35 U.S.C. § 103(a) in View of the Combination of Jurgen, Toyota '599, and Chasteen.
- The 14<sup>th</sup> Proposed Rejection: Claims 2, 4, 5, 8, 10, 12, and 15 are alleged as Obvious Under 35 U.S.C. § 103(a) in View of the Combination of Jurgen, Volkswagen '070, and Chasteen.



- The 15<sup>th</sup> Proposed Rejection: Claim 18 is alleged as Obvious Under 35 U.S.C. § 103(a) in View of the Combination of Jurgén, Toyota '599, Davidian, and Tonkin.
- The 16<sup>th</sup> Proposed Rejection: Claim 18 is alleged as Obvious Under 35 U.S.C. § 103(a) in View of the Combination of Jurgén, Volkswagen '070, Davidian, and Tonkin.
- The 17<sup>th</sup> Proposed Rejection: Claim 18 is alleged as Obvious Under 35 U.S.C. § 103(a) in View of the Combination of Jurgén, Saturn '452, Davidian, and Tonkin.
- The 18<sup>th</sup> Proposed Rejection: Claims 24 and 25 are alleged as Obvious Under 35 U.S.C. § 103(a) in View of the Combination of Jurgén, Saturn '452, Davidian and Chasteen.
- The 19<sup>th</sup> Proposed Rejection: Claims 24, 25, and 27 are alleged as Obvious Under 35 U.S.C. § 103(a) in View of the Combination of Jurgén, Toyota '599, Davidian and Chasteen.
- The 20<sup>th</sup> Proposed Rejection: Claims 24, 25, and 27 are alleged as Obvious Under 35 U.S.C. § 103(a) in View of the Combination of Jurgén, Volkswagen '070, Davidian and Chasteen.
- The 21<sup>st</sup> Proposed Rejection: Claim 32 is alleged as Obvious Under 35 U.S.C. § 103(a) in in View of the combination of Davidian and Tonkin.

### **Analysis of Substantial New Question of Patentability**

A SNQ of patentability is raised by a cited patent or printed publication when there is a substantial likelihood that a reasonable examiner would consider the prior art patent or printed publication important in deciding whether or not the claim is patentable. A SNQ of patentability is not raised by prior art presented in a reexamination request if the Office has previously considered (in an earlier examination of the patent) the same question of patentability as to a patent claim favorable to the patent owner based on the same prior art patents or printed publications. In re Recreative Technologies, 83 F.3d 1394, 38 USPQ2d 1776 (Fed. Cir. 1996). The substantial new question of patentability may be based on art previously considered by the Office if the reference is presented in a new light or a different way that escaped review during earlier examination. MPEP §2216.

It is not sufficient that a request for reexamination merely proposes one or more rejections of a patent claim or claims as a basis for reexamination. It must first be demonstrated that a patent or printed publication that is relied upon in a proposed rejection presents a new, non-cumulative technological teaching that was not previously considered and discussed on the record during the prosecution of the application that resulted in the patent for which reexamination is requested, and during the prosecution of any other prior proceeding involving the patent for which reexamination is requested. MPEP §2216.

### **Basis of SNQ**

The '781 Patent was issued on September 21, 1999 from the '270 Application, filed on March 10, 1997. The previous Examiner of the '270 Application concluded the reasons for allowance for claims 1, 2, 4, 5, 7, 8, 10, 12, 13, 15, and 17 – 27 was the prior art failed to teach

or suggest upshift or downshift notification circuits. Therefore the limitations that are the basis of the SNQ of patentability affecting independent claims 1, 7, 13, 17, 23, 26, and their dependent claims 2, 4, 5, 8, 10, 12, 15, 18 – 22, 24, 25 and 27, teaches the upshift or downshift and reads as follows:

“an upshift notification circuit coupled to said processor subsystem, said upshift notification circuit issuing a notification that said engine of said vehicle is being operated at an excessive speed.”

OR

“a downshift notification circuit coupled to said processor subsystem, said downshift notification circuit issuing a notification that said engine of said vehicle is being operated at an insufficient engine speed.”

With respect to claims 28 - 30, the applicant in the original prosecution emphasized that the prior art failed to teach a fuel overinjection notification circuit that is activated based on three sensors: a road speed sensor, a throttle position sensor, and a manifold pressure sensor. Therefore the limitation disclosed in independent claim 28 which is the basis of the SNQ of patentability, and also affecting dependent claims 29 and 30, reads as follows:

“said fuel overinjection notification circuit issuing a notification that excessive fuel is being supplied to said engine of said vehicle.;said processor subsystem determining whether to activate said fuel overinjection notification sensor based upon data received from said road speed sensor, said throttle position sensor and said manifold pressure sensor.”

With respect to claims 31 and 32, the applicant in the original prosecution emphasized that the prior art failed to teach a vehicle proximity alarm that is activated based upon three parameters: (1) road speed, as determined by a road speed sensor; (2) separation, as determined by a radar detector; and (3) a vehicle speed/stopping distance table stored in a memory subsystem. The prosecution history focused on a vehicle proximity alarm that is activated based on these three parameters and was the basis for the reasons for allowance on these claims. Therefore the limitation disclosed in independent claim 31 which is the basis of the SNQ of patentability, also affecting dependent claim 32, reads as follows:

“said processor subsystem determining whether to activate said vehicle proximity alarm circuit based upon separation distance data received from said radar detector, vehicle speed data received from said road speed sensor and said first vehicle speed/stopping distance table stored in said memory subsystem.”

#### **Alleged SNQ based upon Jurgen**

Jurgen is presented to determine if a SNQ of patentability regarding Independent claims 1, 7, 13, 17, 23, 26, 28 of the '781 Patent is raised as stated in the First to Ninth proposed rejections, see above. Jurgen was not present as prior art in prior prosecutions of the application which became the '781 Patent.

Jurgen discloses an electronic engine control system that receives sensor inputs, evaluates them, and determines the necessary outputs to provide for optimal drivability.

(Jurgen, page 12.1). Jurgen also discloses that these sensors monitor engine speed (page 7.6), road speed (pages 7.8, 14.3), manifold pressure (pages 2.5, 2.7), and throttle position (page 12.21). Jurgen also discloses that the use of processor subsystems to receive inputs from these sensors was known. (Pages 12.1, 13.6, 22.6). "During the entire operating time of the vehicle, the ECUs are constantly supervising the sensors they are connected to." (Page 22.6). Jurgen illustrates these hardware parts:

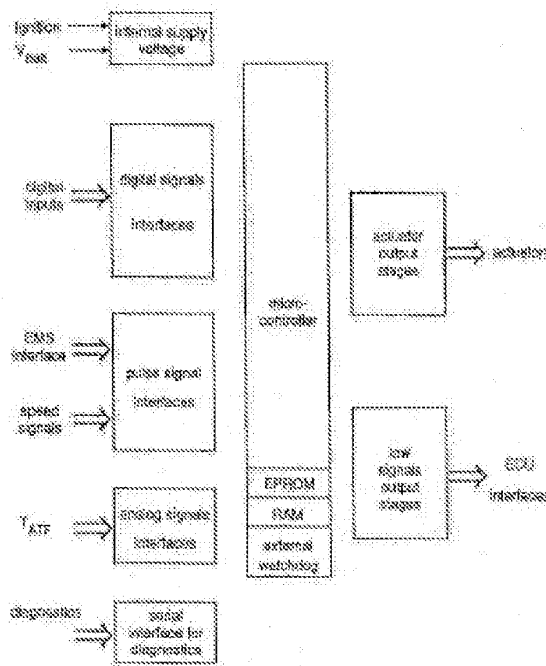

FIGURE 13.1 Overview of hardware parts.

Jurgen also discloses that the transmission can be controlled by calculating the necessary shift points based upon throttle position, the accelerator pedal position (e.g., throttle position), and the vehicle speed. "In the event that the particular shift characteristic is crossed (excessive/insufficient) by one of either of the two input valves, the electronic ECU releases the shift by

activating the related actuator. This can be a direct shift into the target gear or by a serial activation of specific actuators in a fixed sequence to the target gear, depending on the transmission hardware design." (Page 13.9). "The shift point limitations are made, on the one hand, by the highest admissible engine speed for each application." *Id.* The TCU (transmission control unit) stores shift maps that provide notifications to the transmission regarding whether and when to shift. (Page 13.14). Jurgen, therefore, discloses "an upshift[/downshift] notification circuit coupled to said processor subsystem, said upshift[/downshift] notification circuit issuing a notification that said engine of said vehicle is being operated at an excessive[/insufficient] speed" as taught in Independent claims 1, 7, 13, 17, 23, and 26.

Accordingly, these teachings would be important to a reasonable examiner in deciding patentability as to at least Independent claims 1, 7, 13, 17, 23, and 26 of the '781 Patent. Further, Jurgen teachings are new and non-cumulative. Accordingly, Jurgen raises a substantial new question of patentability as to at least independent claims 1, 7, 13, 17, 23, and 26 of the '781 Patent that have not been decided in a previous examination. Dependent claims 2, 4, 5, 8, 10, 12, 15, 18 – 22, 24, 25, and 27 are brought in at least due to their dependency on Independent claims 1, 7, 13, 17, 23, and 26.

Jurgen discloses fuel injection notification circuit, which issues a notification to shut off fuel in certain situations. For Example, the ECU disclosed in Jurgen can shut of fuel in certain situation by evaluating the throttle position, engine RPM, and vehicle speed. (Page 12.4). Additionally, the ECU can shut off fuel injectors when a maximum speed is achieved (page 12.14). The ECU provides a notification to the fuel injectors when a fuel cutoff state is reached.

Jurgen discloses based upon data received from said plurality of sensors, when to activate said fuel injection circuit and when to activate said upshift/downshift notification circuit. For example, the combination of the ECU, which monitors all of the vehicle's sensors (see above) and the TCU, which stores the shift maps, can send notification circuits to the fuel injectors and/or the transmission in order to alleviate a fuel overinjection condition or shift the engine.

Accordingly, Jurgen teachings, either alone or in combination with a secondary reference, would be important to a reasonable examiner in deciding patentability as to at least Independent claim 28 of the '781 Patent. Further, Jurgen teachings are new and non-cumulative.

Accordingly, Jurgen raises a substantial new question of patentability as to at least independent claim 28 of the '781 Patent that have not been decided in a previous examination. Dependent claims 29 and 30 are brought in at least due to their dependency on Independent claim 28.

#### **Alleged SNQ based upon Saturn '452**

Saturn '452 Patent is presented to determine if a SNQ of patentability regarding Independent claims 1, 13, 17, 23, and 26 of the '781 Patent is raised as stated in the First and Sixth proposed rejection, see above. Saturn '452 was not present as prior art in prior prosecutions of the application which became the '781 Patent.

Saturn '452 discloses an upshift notification circuit connected to the control unit, which indicates "via line 60 the state of an upshift indicator light or equivalent visual display." Col. 2, lines 42 to 55. Therefore, it is seen that Saturn '452 discloses "an upshift notification circuit coupled to said processor subsystem, said upshift notification circuit issuing a notification that said engine of said vehicle is being operated at an excessive speed" and "said processor

subsystem determining, based upon data received from said plurality of sensors, . . . when to activate said upshift notification circuit." as taught in Independent claims 1, 17, and 23.

Accordingly, these teachings would be important to a reasonable examiner in deciding patentability as to at least Independent claims 1, 17, and 23 of the '781 Patent. Further, Saturn '452 teachings are new and non-cumulative. Accordingly, Saturn '452 raises a substantial new question of patentability as to at least independent claims 1, 17, and 23 of the '781 Patent that have not been decided in a previous examination. Dependent claims 2, 4, 5, 18 – 22, 24, and 25 are brought in at least due to their dependency on Independent claims 1, 17, and 23.

#### **Alleged SNQ based upon Toyota '599**

Toyota '599 is presented to determine if a SNQ of patentability regarding Independent claims 1, 7, 13, 17, 23, and 26 of the '781 Patent is raised as stated in the Second and Forth proposed rejections, see above. Toyota '599 was not present as prior art in prior prosecutions of the application which became the '781 Patent.

Toyota '599 discloses a "shift indication apparatus coupled to a plurality of sensors. An overview of this system is illustrated in Figure 1:

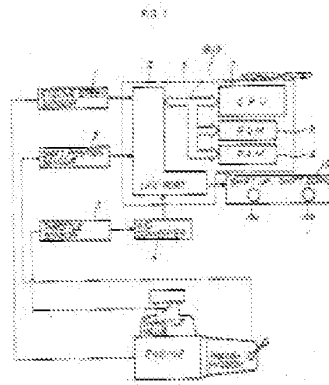



Toyota '599 discloses that indicator lamps that tell the driver to shift up or shift down are lit by the microcomputer in order to tell the driver when to shift to improve fuel economy "Namely, in this step, the speed change operation indicating signal is applied to the indicator or display 10 from the microcomputer 5 through the I/O port 6. As a result, a particular lamp in this case, a shift up indicating lamp in the indicator 10, is illuminated, thus indicating to the drive that the speed change from current shift position to the one step shifting up position  $SP_{+1}$  is preferable." Col. 5, line 63 to col. 6, line 2. "However, only when either one of the assumed fuel consumption rates above is better than the current fuel consumption rate  $B_c$ , the corresponding shift-up lamp or shift-down lamp in the indicator 10 is illuminated, thus indicating the necessity of the speed change operation." E.g. col. 7, lines 29 to 38. Therefore, Toyota '599 discloses "an upshift[/downshift] notification circuit coupled to said processor subsystem, said upshift[/downshift] notification circuit issuing a notification that said engine of said vehicle is being operated at an excessive[/insufficient] speed" and "said processor subsystem determining, based upon data received from said plurality of sensors,.. when to activate said upshift[/downshift] notification circuit."

Accordingly, these teachings would be important to a reasonable examiner in deciding patentability as to at least Independent claims 1, 7, 13, 17, 23, and 26 of the '781 Patent. Further, Toyota '599 teachings are new and non-cumulative. Accordingly, Toyota '599 raises a substantial new question of patentability as to at least independent claims 1, 7, 13, 17, 23, and 26 of the '781 Patent that have not been decided in a previous examination. Dependent claims 2, 4,

5, 8, 10, 12, 15, 18 – 22, 24, 25, and 27 are brought in at least due to their dependency on Independent claims 1, 7, 13, 17, 23, and 26.

### **Alleged SNQ based upon Volkswagen '070**

Volkswagen '070 is presented to determine if a SNQ of patentability regarding Independent claims 1, 7, 13, 17, 23, and 26 of the '781 Patent is raised as stated in the Third and Fifth proposed rejections, see above. Volkswagen '070 was not present as prior art in prior prosecutions of the application which became the '781 Patent.

Volkswagen '070 discloses:

Volkswagen '070 discloses a device "that assists the operator of [an] internal combustion engine equipped with a conventional transmission." Page 5. The device receives an engine speed signal "with the aid of known sensor systems" and uses it to activate an "engine-speed dependent change-over switch 6." Page 7. Volkswagen '070 describes two operating ranges, I and II, and the change-over switch 6 indicates that an upshift or downshift is necessary when the limits of those ranges (e.g., the RPM set point) is reached. Pages 6-8. For example, Figure 2 of Volkswagen '070 illustrates the change-over switch, which receives the engine speed signal and determines when to activate the upshift and downshift notification lamps 4 and 6:

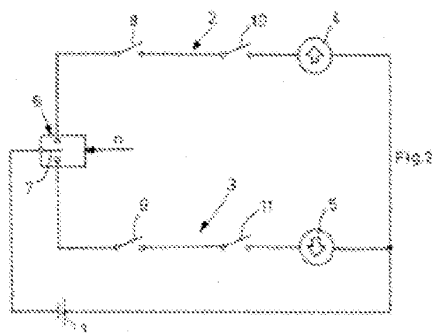

Accordingly, these teachings would be important to a reasonable examiner in deciding patentability as to at least Independent claims 1, 7, 13, 17, 23, and 26 of the '781 Patent. Further, Volkswagen '070 teachings are new and non-cumulative. Accordingly, Volkswagen '070 raises

a substantial new question of patentability as to at least independent claims 1, 7, 13, 17, 23, and 26 of the '781 Patent that have not been decided in a previous examination.

#### **Alleged SNQ based upon Davidian**

Davidian is presented to determine if a SNQ of patentability regarding claims 17, 23, 26, and 31 of the '781 Patent is raised as stated in the Fourth, Fifth, Sixth and Tenth proposed rejection, see above. Davidian was not present as prior art in prior prosecutions of the application which became the '781 Patent.

Davidian discloses a memory subsystem that stores a vehicle speed/stopping distance table. *"Computer module 90 also includes information about the vehicle braking distances as a function of speed. This is preferably in the form of a look-up table, for example, provided by the manufacturer for predetermined defined conditions concerning road type, skidding danger, vehicle load and tires pressure, and is stored in a ROM (read-only memory) of the microcomputer so that it can be changed periodically if necessary."* Col. 9, lines 20 to 27. This memory subsystem is a part of the microcomputer 4, as illustrated in FIG. 6A. Therefore, Davidian discloses "a memory subsystem, coupled to said processor subsystem, said memory subsystem storing a first vehicle speed/stopping distance table." Davidian discloses a vehicle proximity alarm circuit, which activates a collision alarm when a calculated "Collision Distance" is close to a calculated "Stopping Distance." "A determination is also made of the collision distance CD which is equal to the stopping distance SD divided by the collision safety factor CSF, e.g., 1.25 in the example illustrated above, such that should the distance between the vehicle and the object come within the collision distance CD, the collision alarm is then

actuated." Col. 12, line 59 to col. 13, line 11. The collision alarm, may be an audio alarm or a visual alarm. Col. 9, lines 52 to 56. The determination whether to activate the collision alarm is made by the calculation module 90, which is part of the microcomputer 4. *See* col. 12, line 27 ("Operation of the Calculation Module 90"). Therefore, Davidian discloses "a vehicle proximity alarm circuit coupled to said processor subsystem, said vehicle proximity alarm circuit issuing an alarm that said vehicle is too close to said object." Davidian also discloses that the processor subsystem determines when to activate the proximity alarm based on (1) separation distance data (received from the front vehicle space sensor 8); (2) vehicle speed data (received from vehicle speed sensor 12); and (3) the vehicle speed/stopping distance table stored in memory. The radar input, the vehicle speed input, and the vehicle speed/stopping distance tables are all located in the calculation module 90, which it uses to calculate stopping distance and collision distance. Therefore, Davidian discloses "said processor subsystem determining whether to activate said vehicle proximity alarm circuit based upon separation distance data received from said radar detector, vehicle speed data received from said road speed sensor and said first vehicle speed/stopping distance table stored in said memory subsystem."

Accordingly, these teachings would be important to a reasonable examiner in deciding patentability as to at least Independent claim 31 of the '781 Patent. Further, Davidian teachings are new and non-cumulative. Accordingly, Davidian raises a substantial new question of patentability as to at least independent claim 31 of the '781 Patent that have not been decided in a previous examination. Dependent claim 32 is brought in at least due to their dependency on Independent claim 31.

Davidian does not disclose “an upshift notification circuit coupled to said processor subsystem, said upshift notification circuit issuing a notification that said engine of said vehicle is being operated at an excessive speed,” OR “a downshift notification circuit coupled to said processor subsystem, said downshift notification circuit issuing a notification that said engine of said vehicle is being operated at an insufficient engine speed.” Davidian teachings alone would not be pertinent to a reasonable examiner in deciding patentability as to at least Independent claims 1, 17, 23, and 26 of the ‘781 Patent. Accordingly, Davidian does not raises a substantial new question of patentability as to independent claims 1, 17, 23, and 26 of the ‘781 Patent.

**Alleged SNQ based upon Nissan ‘055**

Nissan ‘055 is presented to determine if a SNQ of patentability regarding Independent claim 28 of the ‘781 Patent is raised as stated in the Seventh proposed rejection, see above. Nissan ‘055 was not present as prior art in prior prosecutions of the application which became the ‘781 Patent.

Nissan ‘055 discloses a control system that "controls the number of fuel injected cylinders" in order to increase fuel economy. Abstract. Figure 1 of Nissan '055 discloses that a throttle opening sensor and vehicle velocity sensor are inputs to the system:

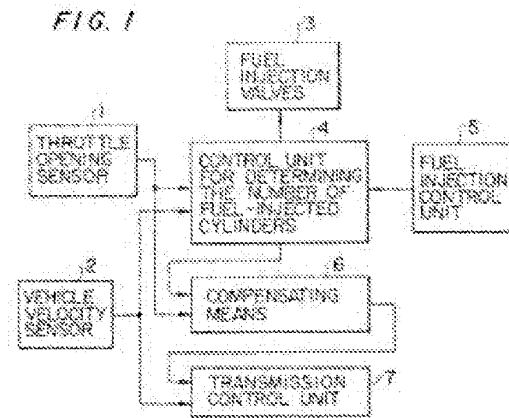

Nissan '055 discloses that "when the signal from the vehicle velocity sensor 2 exceeds a predetermined level and at the same time the signal from the throttle opening sensor 1 falls below another predetermined level, the control unit 4 determines the number of cylinders to which fuel is actually injected based on the two signals applied and stops injection of fuel to specified one or more cylinders." Col. 2, lines 59 to 66. Nissan '055 does not refer to the use of a manifold pressure sensor.

Nissan '055 does not disclose "said processor subsystem determining whether to activate said fuel overinjection notification sensor based upon data received from said road speed sensor, said throttle position sensor and said manifold pressure sensor" since Nissan '055 does not take into consideration the manifold pressure in their determination.

Nissan '055 teachings alone would not be pertinent to a reasonable examiner in deciding patentability as to at least Independent claim 28 of the '781 Patent. Accordingly, Nissan '055 alone does not raise a substantial new question of patentability as to independent claim 28 of the '781 Patent.

### Alleged SNQ based upon Mack '324

Mack '324 is presented to determine if a SNQ of patentability regarding Independent claim 28 of the '781 Patent is raised as stated in the Eighth proposed rejection, see above. Mack '324 was not present as prior art in prior prosecutions of the application which became the '781 Patent.

Mack '324 discloses an engine and vehicle management and control system. Figure 1 of Mack '324 illustrates an overview of the system:

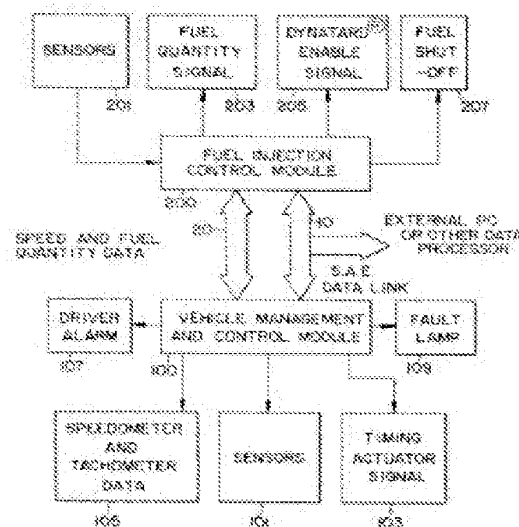

The fuel injection control module 200 in Mack '324 contains a microprocessor 2001, and receives inputs from sensors 201 and outputs a fuel quantity signal 203 and a fuel shut-off enable signal 207. Col. 2, lines 33 to 27. Figure 3 illustrates the details of the fuel injection control module:

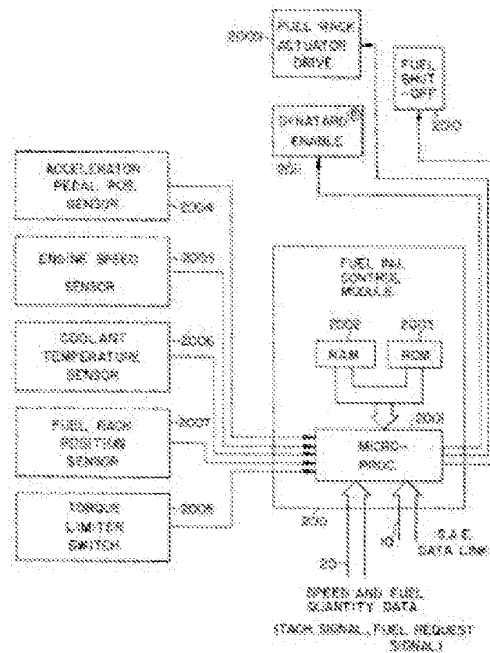

Inputs to the fuel injection control module include sensor inputs from "an accelerator pedal position sensor 2005, an engine speed sensor 2005, a coolant temperature sensor 2006, a fuel rack position sensor 2007, and a torque limiter switch 2008." Col. 3, lines 57 to 61. Mack '324 discloses a fuel injection signal that stops fuel being injected to the engine when certain overspeed conditions are met. Col. 6, lines 24 to 53. The fuel request signal is sent by the fuel injection control module, to which the sensors are input. However, Mack '324 does not refer to the use of a manifold pressure sensor. Therefore, Mack '324 does not disclose "said processor subsystem determining whether to activate said fuel overinjection notification sensor based upon data received from said road speed sensor, said throttle position sensor and said manifold pressure sensor," since Mack '324 does not need a manifold pressure sensor in their



determination as to how much fuel is sent to the engine and said system prevents too much fuel from being injected into the system.

Accordingly, Mack '324 teachings alone would not be important to a reasonable examiner in deciding patentability as to at least Independent claim 28 of the '781 Patent. Mack '324 teachings are new and non-cumulative. Accordingly, Mack '324 alone does not raise a substantial new question of patentability as to independent claim 28 of the '781 Patent.

#### **Alleged SNQ based upon GM '753**

GM '753 is presented to determine if a SNQ of patentability regarding Independent claim 28 of the '781 Patent is raised as stated in the Ninth proposed rejection, see above. GM '753 was not present as prior art in prior prosecutions of the application which became the '781 Patent.

GM '753 discloses a "warning system for providing an indication when the fuel consumption of a throttle controlled vehicle having an internal combustion engine with an intake manifold exceeds pre-established levels." The vacuum transducer 12 of GM '753 "is effective to generate a voltage having a magnitude which progressively changes with a progressively increased manifold intake level." Col. 1, lines 38 to 55. The speed transducer "generates a series of voltage pulses having a frequency progressively increasing with increasing vehicle speed." Col. 2, lines 34 to 51. These inputs are fed to an analog circuit, which is used to send current to a lamp when a level "determined to represent excessive fuel consumption" is reached. Col. 2, lines 52 to 58. "When the vehicle is operated in a manner such that the manifold vacuum decreases below the manifold vacuum trigger level established at the instantaneous vehicle speed, *the output of the summing switch 14 swings positive to effect energization of the lamp 30 to provide*

*an indication of fuel consumption in excess of the predetermined amount at that speed."* Col. 3, lines 20 to 27. GM '753 does not refer to the use of a throttle position sensor, nor any other specific sensor in their system. There is also no processor in which the information is determined as to whether or not to activate said fuel overinjection notification sensor. Therefore, GM '753 does not disclose "said processor subsystem determining whether to activate said fuel overinjection notification sensor based upon data received from said road speed sensor, said throttle position sensor and said manifold pressure sensor."

Accordingly, these teachings alone would not be important to a reasonable examiner in deciding patentability as to at least Independent claim 28 of the '781 Patent. GM '753 teachings are new and non-cumulative. Accordingly, GM '753 alone does not raise a substantial new question of patentability as to independent claim 28 of the '781 Patent.

#### **Alleged SNQ based upon Tonkin**

Tonkin is presented to determine if a SNQ of patentability regarding Independent claim 31 of the '781 Patent is raised as stated in the Eleventh proposed rejection, see above. Tonkin was not present as prior art in prior prosecutions of the application which became the '781 Patent.

Tonkin discloses a system that calculates a safety envelope and displays a visible warning when a rear-facing vehicle is getting too near. Abstract. Tonkin discloses the use of a radar sensor in order to determine "distance of separation and/or a relative velocity of a trailing vehicle." Page 1, lines 23 - 29. *See also* page 5, lines 4 - 9, "The sensor means for sensing the distance and velocity of the trailing vehicle may comprise a radar system." Tonkin also discloses

the use of sensors, including a velocity sensing means comprising "a conventional speed sensing device fitted to the vehicle's transmission train." Page 5, lines 17 - 19. Tonkin discloses the use of a memory subsystem that stores parameters in a lookup table, including a vehicle speed/stopping distance table. For example, Tonkin discloses that predetermined driving parameters "may for example be stored in a look up table." Page 3, lines 25 - 32. Additionally, the control system that activates the vehicle proximity alarm relies in part on "known safe stopping distances such as those published by the Minister of Transport, in which a vehicle will stop when the brakes are applied." Page 16, lines 2 - 21. Finally, Tonkin discloses that a look-up table or database could be provided for unsafe closing speeds, which could be varied according to the velocity of the subject vehicle." Page 17, lines 7 - 25. Tonkin discloses that the processor subsystem determines when to activate the proximity alarm circuit based upon (1) separation distance data received from said radar detector; (2) vehicle speed data received from said road speed sensor; and (3) the vehicle speed/stopping distance table. For example, the radar system is "operable to sense a distance of separation and/or a relative velocity of a trailing vehicle." Page 1, lines 32 - 34. The processor subsystem "is operable to process the received velocity signal and data signals to determine the existence of an unsafe condition." The velocity signal used by the processing means is the vehicle velocity signal determined from the vehicle speed sensor. Page 5, lines 17 - 19. The data signals include the separation data (determined from the radar), and the determination regarding whether to activate the alarm is made, in part, using the safe stopping distances provided in the look-up table. Page 17, lines 7 to 25. Therefore, Tonkin discloses "said processor subsystem determining whether to activate said vehicle proximity alarm circuit based upon separation distance data received from said radar detector, vehicle speed data received from

said road speed sensor and said first vehicle speed/stopping distance table stored in said memory subsystem."

Accordingly, these teachings would be important to a reasonable examiner in deciding patentability as to at least Independent claim 31 of the '781 Patent. Further, Tonkin teachings are new and non-cumulative. Accordingly, Tonkin raises a substantial new question of patentability as to at least independent claim 31 of the '781 Patent that have not been decided in a previous examination. Dependent claim 32 is brought in at least due to their dependency on Independent claim 31.

#### **Alleged SNQ based upon Doi**

Doi is presented to determine if a SNQ of patentability regarding Independent claim 31 of the '781 Patent is raised as stated in the Eleventh proposed rejection, see above. Doi was present as prior art in prior prosecutions of the application which became the '781 Patent.

In an amendment from the Applicant, dated February 8, 1999, the Applicant asserted that claim 31, previously claim 37 in the '270 Application:

The Applicants respectfully submit that new Claims 37-38, as presented herein, are neither taught nor suggested by the proposed combination of Chastoon and Doi et al. The Examiner properly cited Doi et al. as disclosing a vehicle running mode detection system equipped with a radar detector and an alarm circuit. The Applicants respectfully note, however, that the system disclosed in Doi et al. determines alert conditions relative to the proximity between a vehicle and a forward object based upon changes in the distance separating the vehicle and the forward object. In contrast, Applicants' apparatus for optimizing vehicle operation set forth in Claim 37 includes a processor subsystem configured to activate a vehicle proximity alarm circuit based upon road speed (as determined by a road speed sensor), separation (as determined by a radar detector) and a vehicle speed/stopping distance table stored in a memory subsystem.

Also see, The Request pp. 11-14 for more details.

The Examiner of the '270 Application subsequently issued a Notice of Allowance stating that the prior art did not teach the limitation in question, which is the basis for the SNQ of claim 31. It is further seen in the Request, pages 80 – 83, that the Requester utilizes Doi in the same way as what was already discussed by the Applicant and agreed to by the Examiner of the '270 Application in their reasons for allowance, i.e., Doi does not disclose the limitation that is the basis for SNQ for claim 31. Doi is not new prior art and also not used or presented in a new light that would raise a SNQ for claim 31. Therefore, it is seen that Doi alone does not disclose a vehicle proximity alarm that is activated based upon three parameters: (1) road speed, as determined by a road speed sensor; (2) separation, as determined by a radar detector; and (3) a vehicle speed/stopping distance table stored in a memory subsystem.

Accordingly, these teachings would **not** be important to a reasonable examiner in deciding patentability as to at least Independent claim 31 of the '781 Patent. Accordingly, Doi alone does not raise a substantial new question of patentability as to independent claim 31 of the '781 Patent.

### ***Conclusion***

A Request for *ex parte* reexamination of United States Patent Number 5,954,781 is Ordered.

A substantial new question of patentability affecting claims 1, 2, 4, 5, 7, 8, 10, 12, 13, 15, and 17 – 30 of United States Patent Number 5,954,781 is raised by the Request for *ex parte*

Art Unit: 3992

reexamination based on the Jorgen, Saturn '452, Toyota '599, and Volkswagen '070 cited areas supplied by the Requester.

A substantial new question of patentability affecting claims 31 and 32 of United States Patent Number 5,954,781 is raised by the Request for *ex parte* reexamination based on the Davidian, and Tonkin cited areas supplied by the Requester.

Therefore, claims 1, 2, 4, 5, 7, 8, 10, 12, 13, 15, and 17 – 32 will be reexamined.

Nissan '055, Mack '324, and GM '753 alone do **Not** raise a SNQ affecting claims 28 – 30.

Davidian alone does **Not** raise a SNQ affecting claims 1, 2, 4, 5, 7, 8, 10, 12, 13, 15, and 17 – 27.

Doi alone does **Not** raise a SNQ affecting claims 31 and 32.

Extensions of time under 37 CFR 1.136(a) will not be permitted in these proceedings because the provisions of 37 CFR 1.136 apply only to "an applicant" and not to parties in a reexamination proceeding. Additionally, 35 U.S.C. 305 requires that *ex parte* reexamination proceedings "will be conducted with special dispatch" (37 CFR 1.550(a)). Extensions of time in *ex parte* reexamination proceedings are provided for in 37 CFR 1.550(c).

### **Notification of Concurrent Proceedings**

The patent owner is reminded of the continuing responsibility under 37 CFR 1.985 to apprise the Office of any litigation activity, or other prior or concurrent proceeding, involving the '469 Patent throughout the course of this reexamination proceeding. The third party requester is

also reminded of the ability to similarly apprise the Office of any such activity or proceeding throughout the course of this reexamination proceeding. See MPEP §§ 2207, 2282 and 2286.

## CORRESPONDENCE

**All** correspondence relating to this ex parte reexamination proceeding should be directed:

By EFS: Registered users may submit via the electronic filing system EFS-Web, at <https://sportal.uspto.gov/authenticate/authenticateuserlocalepf.html>.

By Mail to: Mail Stop *Ex Parte* Reexam  
Central Reexamination Unit  
Commissioner for Patents  
United States Patent & Trademark Office  
P.O. Box 1450  
Alexandria, VA 22313-1450

By FAX to: (571) 273-9900  
Central Reexamination Unit

By hand: Customer Service Window  
Randolph Building  
401 Dulany Street  
Alexandria, VA 22314

For EFS-Web transmissions, 37 CFR 1.8(a)(1)(i) (C) and (ii) states that correspondence (except for a request for reexamination and a corrected or replacement request for reexamination) will be considered timely filed if (a) it is transmitted via the Office's electronic filing system in accordance with 37 CFR 1.6(a)(4), and (b) includes a certificate of transmission for each piece of correspondence stating the date of transmission, which is prior to the expiration of the set period of time in the Office action.

Art Unit: 3992

Any inquiry concerning this communication or earlier communications from the Examiner, or as to the status of this proceeding, should be directed to the Central Reexamination Unit at telephone number (571) 272-7705.

Signed:

/David E. England/  
Primary Examiner, Art Unit 3992

Conferees:

/Michael J. Yigdall/  
Primary Examiner, Art Unit 3992

/Fred Ferris/  
Acting SPRS CRU



<b>Order Granting / Denying Request For Ex Parte Reexamination</b>	<b>Control No.</b> 90/013,252	<b>Patent Under Reexamination</b> 5,954,781
	<b>Examiner</b> DAVID ENGLAND	<b>Art Unit</b> 3992

**--The MAILING DATE of this communication appears on the cover sheet with the correspondence address--**

The request for *ex parte* reexamination filed 22 May 2014 has been considered and a determination has been made. An identification of the claims, the references relied upon, and the rationale supporting the determination are attached.

Attachments: a)  PTO-892,      b)  PTO/SB/08,      c)  Other: IDS List

1.  The request for *ex parte* reexamination is GRANTED.

RESPONSE TIMES ARE SET AS FOLLOWS:

For Patent Owner's Statement (Optional): TWO MONTHS from the mailing date of this communication (37 CFR 1.530 (b)). **EXTENSIONS OF TIME ARE GOVERNED BY 37 CFR 1.550(c).**

For Requester's Reply (optional): TWO MONTHS from the **date of service** of any timely filed Patent Owner's Statement (37 CFR 1.535). **NO EXTENSION OF THIS TIME PERIOD IS PERMITTED.** If Patent Owner does not file a timely statement under 37 CFR 1.530(b), then no reply by requester is permitted.

2.  The request for *ex parte* reexamination is DENIED.

This decision is not appealable (35 U.S.C. 303(c)). Requester may seek review by petition to the Commissioner under 37 CFR 1.181 within ONE MONTH from the mailing date of this communication (37 CFR 1.515(c)). **EXTENSION OF TIME TO FILE SUCH A PETITION UNDER 37 CFR 1.181 ARE AVAILABLE ONLY BY PETITION TO SUSPEND OR WAIVE THE REGULATIONS UNDER 37 CFR 1.183.**

In due course, a refund under 37 CFR 1.26 ( c ) will be made to requester:

- a)  by Treasury check or,  
b)  by credit to Deposit Account No. \_\_\_\_\_, or  
c)  by credit to a credit card account, unless otherwise notified (35 U.S.C. 303(c)).

/DAVID ENGLAND/ Primary Examiner, Art Unit 3992		
--	--	--

cc:Requester ( if third party requester )

<b>Reexamination</b> 	<b>Application/Control No.</b> 90013252	<b>Applicant(s)/Patent Under Reexamination</b> 5,954,781
	<b>Certificate Date</b>	<b>Certificate Number</b>

<b>Requester Correspondence Address:</b>	<input type="checkbox"/> <b>Patent Owner</b>	<input checked="" type="checkbox"/> <b>Third Party</b>
KENYON & KENYON LLP ONE BROADWAY NEW YORK, NY 10004		

<b>LITIGATION REVIEW</b> <input type="checkbox"/>	/DE/ (examiner initials)	06/20/2014 (date)
<b>Case Name</b>		<b>Director Initials</b>
1:13cv8413 (OPEN)		
1:13cv8416 (OPEN)		
1:13cv8418 (OPEN)		
1:13cv8419 (OPEN)		
1:13cv8421 (OPEN)		

<b>COPENDING OFFICE PROCEEDINGS</b>	
<b>TYPE OF PROCEEDING</b>	<b>NUMBER</b>

/DAVID ENGLAND/ Primary Examiner.Art Unit 3992
---

Receipt date: 05/22/2014

<b>LIST OF DOCUMENTS CITED BY THIRD PARTY REQUESTER IN EX PARTE REEXAMINATION</b>	PATENT NO. 5,954,781	PATENTEE Harvey SLEPIAN et al.
	PATENT DATE September 21, 1999	

**U. S. PATENT DOCUMENTS**

EXAM. INITIAL	PATENT/ PUBLICATION NUMBER	NAME	PATENT/ PUBLICATION DATE	CLASS	SUBCLASS	FILING DATE
	4,901,701	Chasteen	February 20, 1990			
	4,631,515	Blee et al.	December 23, 1986			
	5,708,584	Doi et al.	January 13, 1998			
	5,477,452	Milunas et al.	December 19, 1995			
	4,559,599	Habu et al.	December 17, 1985			
	5,357,438	Davidian	October 18, 1994			
	4,061,055	Iizuka et al.	December 6, 1977			
	5,121,324	Rini et al.	June 9, 1992			

**FOREIGN PATENT DOCUMENTS**

EXAMINER INITIAL	DOCUMENT NUMBER	COUNTRY	DATE	NAME	SUBCLASS	TRANSLATION	
						YES	NO
	29 26 070*	DE	January 15, 1981			X	
	96/02853	WO	February 1, 1996				

\* - Certified English-language translation is provided.

**OTHER DOCUMENTS**

EXAMINER INITIAL	Name
	"First Amended Complaint for Patent Infringement" filed on January 30, 2014 in <i>VELOCITY PATENT LLC v. AUDI OF AMERICA, INC.</i> , Case No. 1:13-cv-08418-JGB (N.D. Ill.)
	Velocity Patent LLC's Initial Infringement Contentions Pursuant to Local Patent Rule 2.2 to Audi
	Velocity Patent LLC's Initial Infringement Contentions Pursuant to Local Patent Rule 2.2 to Mercedes-Benz
	Velocity Patent LLC's Initial Infringement Contentions Pursuant to Local Patent Rule 2.2 to Chrysler
	Velocity Patent LLC's Initial Infringement Contentions Pursuant to Local Patent Rule 2.2 to Jaguar Land Rover

EXAMINER	/David England/	DATE CONSIDERED	06/20/2014
----------	-----------------	-----------------	------------

EXAMINER: Initial if citation considered, whether or not citation is in conformance with M.P.E.P. 609; draw line through citation if not in conformance and not considered. Include copy of this form with next communication to applicant.

ALL REFERENCES CONSIDERED EXCEPT WHERE LINED THROUGH. /DE/

Receipt date: 05/22/2014

<b>LIST OF DOCUMENTS CITED BY THIRD PARTY REQUESTER IN <i>EX PARTE</i> REEXAMINATION</b>	PATENT NO. 5,954,781	PATENTEE Harvey SLEPIAN et al.
	PATENT DATE September 21, 1999	

**U. S. PATENT DOCUMENTS**

EXAM. INITIAL	PATENT/ PUBLICATION NUMBER	NAME	PATENT/ PUBLICATION DATE	CLASS	SUBCLASS	FILING DATE
	3,925,753	Auman et al.	December 9, 1975			

**FOREIGN PATENT DOCUMENTS**

EXAMINER INITIAL	DOCUMENT NUMBER	COUNTRY	DATE	NAME	SUBCLASS	TRANSLATION	
						YES	NO

**OTHER DOCUMENTS**

EXAMINER INITIAL	Name
	"Automotive Electronics Handbook," pgs. 2.5-2.9, 3.16, 7.6-7.8, 7.21-7.26, 11.3-11.4, 11.24-11.31, 11.55, 12.1-12.36, 13.1-13.21, 14.1-14.9, and 22.1-22.20, published in 1995, by Ronald Jurgen
	Certified English-language translation of German Patent Application Publication No. 29 26 070

EXAMINER  /David England/	DATE CONSIDERED  06/20/2014
EXAMINER: Initial if citation considered, whether or not citation is in conformance with M.P.E.P. 609; draw line through citation if not in conformance and not considered. Include copy of this form with next communication to applicant.	

ALL REFERENCES CONSIDERED EXCEPT WHERE LINED THROUGH. /DE/

<b>Search Notes</b>  	<b>Application/Control No.</b>  90013252	<b>Applicant(s)/Patent Under Reexamination</b>  5,954,781
	<b>Examiner</b>  DAVID ENGLAND	<b>Art Unit</b>  3992

CPC- SEARCHED		
Symbol	Date	Examiner

CPC COMBINATION SETS - SEARCHED		
Symbol	Date	Examiner

US CLASSIFICATION SEARCHED			
Class	Subclass	Date	Examiner

SEARCH NOTES		
Search Notes	Date	Examiner
Searched references in IDS	6/18/14	/DE/

INTERFERENCE SEARCH			
US Class/ CPC Symbol	US Subclass / CPC Group	Date	Examiner

	/DAVID ENGLAND/ Primary Examiner.Art Unit 3992
--	---

Under the Paperwork Reduction Act of 1995 no persons are required to respond to a collection of information unless it displays a valid OMB control number

<b>REEXAMINATION OR SUPPLEMENTAL EXAMINATION – PATENT OWNER POWER OF ATTORNEY OR REVOCATION OF POWER OF ATTORNEY WITH A NEW POWER OF ATTORNEY AND CHANGE OF CORRESPONDENCE ADDRESS FOR REEXAMINATION OR SUPPLEMENTAL EXAMINATION AND PATENT</b>	Control Number(s)	90013252
	Filing Date(s)	05-22-2014
	First Named Inventor	Harvey Slepian
	Title	Method and Apparatus for Optimizing Vehicle Operation
	Patent Number	5,954,781
	Examiner Name	David E. England
	Attorney Docket No(s)	1089-001

**I. Power of Attorney.** This form may be used to change the Power of Attorney in a reexamination or supplemental examination proceeding (or multiple proceedings where merged). This form may also be used to change the Power of Attorney in the patent file; in such a case, a copy of this form will be placed in both the patent file and the reexamination or supplemental examination proceeding.

**A. Revocation of Previous Power of Attorney.** I hereby revoke all previous patent owner powers of attorney, if any, given:

in the above-identified reexamination or supplemental examination proceeding control number(s) (more than one may be changed only if the proceedings are merged).

in the file of the above-identified patent.

(check BOTH boxes if change in BOTH the patent file and the reexamination or supplemental examination proceeding is requested).

**B. Designation of Power of Attorney.**

A Power of Attorney is submitted herewith.

OR

I hereby appoint Practitioner(s) associated with the Customer Number identified in the box at right as my/our attorney(s) or agent(s) to prosecute the proceeding(s)/patent identified above and selected in section I(A), and to transact all business in the United States Patent and Trademark Office connected therewith:

88360

OR

I hereby appoint Practitioner(s) named below as my/our attorney(s) or agent(s) to prosecute the proceeding(s) identified above, and to transact all business in the United States Patent and Trademark Office connected therewith:

Practitioner(s) Name	Registration Number

Authorization for the Power of Attorney is provided by the signature on page 2 of this form.

This collection of information is required by 37 CFR 1.31, 1.32, and 1.33. The information is required to obtain or retain a benefit by the public, which is to update (and by the USPTO to process) the file of a patent or reexamination proceeding. Confidentiality is governed by 35 U.S.C. 122 and 37 CFR 1.14. This collection is estimated to take 3 minutes to complete, including gathering, preparing, and submitting the completed application form to the USPTO. Time will vary depending upon the individual case. Any comments on the amount of time you require to complete this form and/or suggestions for reducing this burden, should be sent to the Chief Information Officer, U.S. Patent and Trademark Office, U.S. Department of Commerce, P.O. Box 1450, Alexandria, VA 22313-1450. DO NOT SEND FEES OR COMPLETED FORMS TO THIS ADDRESS. SEND TO: Commissioner for Patents, P.O. Box 1450, Alexandria, VA 22313-1450.

If you need assistance in completing the form, call 1-800-PTO-9199 and select option 2.

Under the Paperwork Reduction Act of 1995 no persons are required to respond to a collection of information unless it displays a valid OMB control number

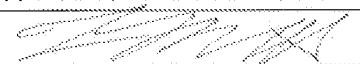
II. Change of Correspondence Address			
Please recognize or change the correspondence address for the above-identified reexamination or supplemental examination proceeding control number(s) (more than one may be changed <b>only</b> if they are merged proceedings) <b>and for the file of the above-identified patent</b> to be:			
<input checked="" type="checkbox"/> The address associated with the above-identified Customer Number.			
OR			
<input type="checkbox"/> The address associated with the Customer Number identified in the box at right: <span style="border: 1px dashed black; display: inline-block; width: 100px; height: 20px; vertical-align: middle;"></span>			
OR			
<input type="checkbox"/> Firm or Individual Name			
Address			
City		State	Zip
Country			
Telephone		Email	
<b>NOTE: THE CORRESPONDENCE ADDRESS FOR THE REEXAMINATION OR SUPPLEMENTAL EXAMINATION PROCEEDING CONTROL NUMBER(S) MUST BE THE SAME AS THAT FOR THE PATENT. SEE 37 CFR 1.33.</b>			
III. Authorization for Power of Attorney and (if selected) Change of Correspondence Address			
I am the:			
<input type="checkbox"/> Inventor, having ownership of the patent being reexamined.			
OR			
<input checked="" type="checkbox"/> Patent owner.			
Statement under 37 CFR 3.73(c) (Form PTO/AIA/96) submitted herewith or filed on _____.			
Signature of Inventor or Patent Owner			Date
Name		Tom Mavrakakis	Telephone
Title and Company		Managing Member of Velocity Patent LLC	
<b>NOTE:</b> Signatures of all the inventors or patent owners of the entire interest or their representative(s) are required. If more than one signature is required, submit multiple forms, check the box below, and identify the total number of forms submitted in the blank below.			
<input checked="" type="checkbox"/> A total of <u>1</u> forms are submitted. If you need assistance in completing the form, call 1-800-PTO-9199 and select option 2.			

## Privacy Act Statement

The **Privacy Act of 1974 (P.L. 93-579)** requires that you be given certain information in connection with your submission of the attached form related to a patent application or patent. Accordingly, pursuant to the requirements of the Act, please be advised that: (1) the general authority for the collection of this information is 35 U.S.C. 2(b)(2); (2) furnishing of the information solicited is voluntary; and (3) the principal purpose for which the information is used by the U.S. Patent and Trademark Office is to process and/or examine your submission related to a patent application or patent. If you do not furnish the requested information, the U.S. Patent and Trademark Office may not be able to process and/or examine your submission, which may result in termination of proceedings or abandonment of the application or expiration of the patent.

The information provided by you in this form will be subject to the following routine uses:

1. The information on this form will be treated confidentially to the extent allowed under the Freedom of Information Act (5 U.S.C. 552) and the Privacy Act (5 U.S.C. 552a). Records from this system of records may be disclosed to the Department of Justice to determine whether disclosure of these records is required by the Freedom of Information Act.
2. A record from this system of records may be disclosed, as a routine use, in the course of presenting evidence to a court, magistrate, or administrative tribunal, including disclosures to opposing counsel in the course of settlement negotiations.
3. A record in this system of records may be disclosed, as a routine use, to a Member of Congress submitting a request involving an individual, to whom the record pertains, when the individual has requested assistance from the Member with respect to the subject matter of the record.
4. A record in this system of records may be disclosed, as a routine use, to a contractor of the Agency having need for the information in order to perform a contract. Recipients of information shall be required to comply with the requirements of the Privacy Act of 1974, as amended, pursuant to 5 U.S.C. 552a(m).
5. A record related to an International Application filed under the Patent Cooperation Treaty in this system of records may be disclosed, as a routine use, to the International Bureau of the World Intellectual Property Organization, pursuant to the Patent Cooperation Treaty.
6. A record in this system of records may be disclosed, as a routine use, to another federal agency for purposes of National Security review (35 U.S.C. 181) and for review pursuant to the Atomic Energy Act (42 U.S.C. 218(c)).
7. A record from this system of records may be disclosed, as a routine use, to the Administrator, General Services, or his/her designee, during an inspection of records conducted by GSA as part of that agency's responsibility to recommend improvements in records management practices and programs, under authority of 44 U.S.C. 2904 and 2906. Such disclosure shall be made in accordance with the GSA regulations governing inspection of records for this purpose, and any other relevant (*i.e.*, GSA or Commerce) directive. Such disclosure shall not be used to make determinations about individuals.
8. A record from this system of records may be disclosed, as a routine use, to the public after either publication of the application pursuant to 35 U.S.C. 122(b) or issuance of a patent pursuant to 35 U.S.C. 151. Further, a record may be disclosed, subject to the limitations of 37 CFR 1.14, as a routine use, to the public if the record was filed in an application which became abandoned or in which the proceedings were terminated and which application is referenced by either a published application, an application open to public inspection or an issued patent.
9. A record from this system of records may be disclosed, as a routine use, to a Federal, State, or local law enforcement agency, if the USPTO becomes aware of a violation or potential violation of law or regulation.



## Electronic Acknowledgement Receipt

<b>EFS ID:</b>	19437543
<b>Application Number:</b>	90013252
<b>International Application Number:</b>	
<b>Confirmation Number:</b>	9999
<b>Title of Invention:</b>	Method and Apparatus for Optimizing Vehicle Operation
<b>First Named Inventor/Applicant Name:</b>	5,954,781
<b>Correspondence Address:</b>	MICHAEL S. BUSH HAYNES AND BOONE LLP 3100 NATIONSBANK PLAZA 901 MAIN STREET DALLAS TX 75202-3789 US 2146515589 -
<b>Filer:</b>	Patrick Duffy Richards
<b>Filer Authorized By:</b>	
<b>Attorney Docket Number:</b>	
<b>Receipt Date:</b>	27-JUN-2014
<b>Filing Date:</b>	22-MAY-2014
<b>Time Stamp:</b>	15:05:14
<b>Application Type:</b>	Reexam (Third Party)

### Payment information:

Submitted with Payment	no
------------------------	----

### File Listing:

Document Number	Document Description	File Name	File Size(Bytes)/ Message Digest	Multi Part /.zip	Pages (if appl.)
1	Assignee showing of ownership per 37 CFR 3.73.	Statement.pdf	121575 f486680a0cf9a85be8c081da5bc7a4959f04d7ce	no	3
<b>Warnings:</b>					
<b>Information:</b>					
2	Power of Attorney	POA.pdf	890969 3621ad656b72041e58a38f2cbf9d636b6b66fad6	no	3
<b>Warnings:</b>					
<b>Information:</b>					
<b>Total Files Size (in bytes):</b>			1012544		
<p><b>This Acknowledgement Receipt evidences receipt on the noted date by the USPTO of the indicated documents, characterized by the applicant, and including page counts, where applicable. It serves as evidence of receipt similar to a Post Card, as described in MPEP 503.</b></p> <p><b><u>New Applications Under 35 U.S.C. 111</u></b>  <b>If a new application is being filed and the application includes the necessary components for a filing date (see 37 CFR 1.53(b)-(d) and MPEP 506), a Filing Receipt (37 CFR 1.54) will be issued in due course and the date shown on this Acknowledgement Receipt will establish the filing date of the application.</b></p> <p><b><u>National Stage of an International Application under 35 U.S.C. 371</u></b>  <b>If a timely submission to enter the national stage of an international application is compliant with the conditions of 35 U.S.C. 371 and other applicable requirements a Form PCT/DO/EO/903 indicating acceptance of the application as a national stage submission under 35 U.S.C. 371 will be issued in addition to the Filing Receipt, in due course.</b></p> <p><b><u>New International Application Filed with the USPTO as a Receiving Office</u></b>  <b>If a new international application is being filed and the international application includes the necessary components for an international filing date (see PCT Article 11 and MPEP 1810), a Notification of the International Application Number and of the International Filing Date (Form PCT/RO/105) will be issued in due course, subject to prescriptions concerning national security, and the date shown on this Acknowledgement Receipt will establish the international filing date of the application.</b></p>					

**STATEMENT UNDER 37 CFR 3.73(c)**Applicant/Patent Owner: Velocity Patent LLCApplication No./Patent No.: 5,954,781 Filed/Issue Date: September 21, 1999Titled: Method and Apparatus for Optimizing Vehicle OperationVelocity Patent LLC, a limited liability company

(Name of Assignee)

(Type of Assignee, e.g., corporation, partnership, university, government agency, etc.)

states that, for the patent application/patent identified above, it is (choose **one** of options 1, 2, 3 or 4 below):

1.  The assignee of the entire right, title, and interest.
2.  An assignee of less than the entire right, title, and interest (check applicable box):
- The extent (by percentage) of its ownership interest is \_\_\_\_\_%. Additional Statement(s) by the owners holding the balance of the interest must be submitted to account for 100% of the ownership interest.
- There are unspecified percentages of ownership. The other parties, including inventors, who together own the entire right, title and interest are:

Additional Statement(s) by the owner(s) holding the balance of the interest must be submitted to account for the entire right, title, and interest.

3.  The assignee of an undivided interest in the entirety (a complete assignment from one of the joint inventors was made). The other parties, including inventors, who together own the entire right, title, and interest are:

Additional Statement(s) by the owner(s) holding the balance of the interest must be submitted to account for the entire right, title, and interest.

4.  The recipient, via a court proceeding or the like (e.g., bankruptcy, probate), of an undivided interest in the entirety (a complete transfer of ownership interest was made). The certified document(s) showing the transfer is attached.

The interest identified in option 1, 2 or 3 above (not option 4) is evidenced by either (choose **one** of options A or B below):

- A.  An assignment from the inventor(s) of the patent application/patent identified above. The assignment was recorded in the United States Patent and Trademark Office at Reel \_\_\_\_\_, Frame \_\_\_\_\_, or for which a copy thereof is attached.
- B.  A chain of title from the inventor(s), of the patent application/patent identified above, to the current assignee as follows:

1. From: Harvey Slepian and Loran Sutton To: TAS Distributing Co., Inc.The document was recorded in the United States Patent and Trademark Office at Reel 008435, Frame 0064, or for which a copy thereof is attached.2. From: TAS Distributing Co., Inc. To: Velocity Patents LLCThe document was recorded in the United States Patent and Trademark Office at Reel 031635, Frame 0364, or for which a copy thereof is attached.

[Page 1 of 2]

This collection of information is required by 37 CFR 3.73(b). The information is required to obtain or retain a benefit by the public which is to file (and by the USPTO to process) an application. Confidentiality is governed by 35 U.S.C. 122 and 37 CFR 1.11 and 1.14. This collection is estimated to take 12 minutes to complete, including gathering, preparing, and submitting the completed application form to the USPTO. Time will vary depending upon the individual case. Any comments on the amount of time you require to complete this form and/or suggestions for reducing this burden, should be sent to the Chief Information Officer, U.S. Patent and Trademark Office, U.S. Department of Commerce, P.O. Box 1450, Alexandria, VA 22313-1450. DO NOT SEND FEES OR COMPLETED FORMS TO THIS ADDRESS. **SEND TO: Commissioner for Patents, P.O. Box 1450, Alexandria, VA 22313-1450**

*If you need assistance in completing the form, call 1-800-PTO-9199 and select option 2.*

**STATEMENT UNDER 37 CFR 3.73(c)**

3. From: Velocity Patents LLC To: Velocity Patent LLC

The document was recorded in the United States Patent and Trademark Office at  
Reel 031635, Frame 0376, or for which a copy thereof is attached.

4. From: \_\_\_\_\_ To: \_\_\_\_\_

The document was recorded in the United States Patent and Trademark Office at  
Reel \_\_\_\_\_, Frame \_\_\_\_\_, or for which a copy thereof is attached.

5. From: \_\_\_\_\_ To: \_\_\_\_\_

The document was recorded in the United States Patent and Trademark Office at  
Reel \_\_\_\_\_, Frame \_\_\_\_\_, or for which a copy thereof is attached.

6. From: \_\_\_\_\_ To: \_\_\_\_\_

The document was recorded in the United States Patent and Trademark Office at  
Reel \_\_\_\_\_, Frame \_\_\_\_\_, or for which a copy thereof is attached.

Additional documents in the chain of title are listed on a supplemental sheet(s).

As required by 37 CFR 3.73(c)(1)(i), the documentary evidence of the chain of title from the original owner to the assignee was, or concurrently is being, submitted for recordation pursuant to 37 CFR 3.11.

[NOTE: A separate copy (i.e., a true copy of the original assignment document(s)) must be submitted to Assignment Division in accordance with 37 CFR Part 3, to record the assignment in the records of the USPTO. See MPEP 302.08]

The undersigned (whose title is supplied below) is authorized to act on behalf of the assignee.

/Patrick D. Richards/  
Signature

June 26, 2014  
Date

Patrick Richards  
Printed or Typed Name

48905  
Title or Registration Number

## Privacy Act Statement

The **Privacy Act of 1974 (P.L. 93-579)** requires that you be given certain information in connection with your submission of the attached form related to a patent application or patent. Accordingly, pursuant to the requirements of the Act, please be advised that: (1) the general authority for the collection of this information is 35 U.S.C. 2(b)(2); (2) furnishing of the information solicited is voluntary; and (3) the principal purpose for which the information is used by the U.S. Patent and Trademark Office is to process and/or examine your submission related to a patent application or patent. If you do not furnish the requested information, the U.S. Patent and Trademark Office may not be able to process and/or examine your submission, which may result in termination of proceedings or abandonment of the application or expiration of the patent.

The information provided by you in this form will be subject to the following routine uses:

1. The information on this form will be treated confidentially to the extent allowed under the Freedom of Information Act (5 U.S.C. 552) and the Privacy Act (5 U.S.C. 552a). Records from this system of records may be disclosed to the Department of Justice to determine whether disclosure of these records is required by the Freedom of Information Act.
2. A record from this system of records may be disclosed, as a routine use, in the course of presenting evidence to a court, magistrate, or administrative tribunal, including disclosures to opposing counsel in the course of settlement negotiations.
3. A record in this system of records may be disclosed, as a routine use, to a Member of Congress submitting a request involving an individual, to whom the record pertains, when the individual has requested assistance from the Member with respect to the subject matter of the record.
4. A record in this system of records may be disclosed, as a routine use, to a contractor of the Agency having need for the information in order to perform a contract. Recipients of information shall be required to comply with the requirements of the Privacy Act of 1974, as amended, pursuant to 5 U.S.C. 552a(m).
5. A record related to an International Application filed under the Patent Cooperation Treaty in this system of records may be disclosed, as a routine use, to the International Bureau of the World Intellectual Property Organization, pursuant to the Patent Cooperation Treaty.
6. A record in this system of records may be disclosed, as a routine use, to another federal agency for purposes of National Security review (35 U.S.C. 181) and for review pursuant to the Atomic Energy Act (42 U.S.C. 218(c)).
7. A record from this system of records may be disclosed, as a routine use, to the Administrator, General Services, or his/her designee, during an inspection of records conducted by GSA as part of that agency's responsibility to recommend improvements in records management practices and programs, under authority of 44 U.S.C. 2904 and 2906. Such disclosure shall be made in accordance with the GSA regulations governing inspection of records for this purpose, and any other relevant (*i.e.*, GSA or Commerce) directive. Such disclosure shall not be used to make determinations about individuals.
8. A record from this system of records may be disclosed, as a routine use, to the public after either publication of the application pursuant to 35 U.S.C. 122(b) or issuance of a patent pursuant to 35 U.S.C. 151. Further, a record may be disclosed, subject to the limitations of 37 CFR 1.14, as a routine use, to the public if the record was filed in an application which became abandoned or in which the proceedings were terminated and which application is referenced by either a published application, an application open to public inspection or an issued patent.
9. A record from this system of records may be disclosed, as a routine use, to a Federal, State, or local law enforcement agency, if the USPTO becomes aware of a violation or potential violation of law or regulation.



UNITED STATES PATENT AND TRADEMARK OFFICE

UNITED STATES DEPARTMENT OF COMMERCE  
 United States Patent and Trademark Office  
 Address: COMMISSIONER FOR PATENTS  
 P.O. Box 1450  
 Alexandria, Virginia 22313-1450  
 www.uspto.gov



Bib Data Sheet

CONFIRMATION NO. 9999

<b>SERIAL NUMBER</b> 90/013,252	<b>FILING OR 371(c) DATE</b> 05/22/2014 <b>RULE</b>	<b>CLASS</b> 701	<b>GROUP ART UNIT</b> 3992	<b>ATTORNEY DOCKET NO.</b>
AIA (First Inventor to File): YES				
<b>INVENTORS</b> 5,954,781, Residence Not Provided; VELOCITY PATENT LLC. (OWNER), ATHERTON, CA; VOLKSWAGEN GROUP OF AMERICA, INC. (3RD PTY. REQ.), HERNDON, VA;				
<b>APPLICANTS</b> KENYON & KENYON LLP, NEW YORK, NY				
<b>** CONTINUING DATA *****</b> This application is a REX of 08/813,270 03/10/1997 PAT 5954781				
<b>** FOREIGN APPLICATIONS *****</b>				
Foreign Priority claimed <input type="checkbox"/> yes <input type="checkbox"/> no 35 USC 119 (a-d) conditions met <input type="checkbox"/> yes <input type="checkbox"/> no <input type="checkbox"/> Met after Allowance	Verified and Acknowledged Examiner's Signature _____ Initials _____	<b>STATE OR COUNTRY</b>	<b>SHEETS DRAWING</b>	<b>TOTAL CLAIMS</b> 32  <b>INDEPENDENT CLAIMS</b> 8
<b>ADDRESS</b> 88360				
<b>TITLE</b> Method and Apparatus for Optimizing Vehicle Operation				
<b>FILING FEE RECEIVED</b> 12000	FEES: Authority has been given in Paper No. _____ to charge/credit DEPOSIT ACCOUNT No. _____ for following:	<input type="checkbox"/> All Fees <input type="checkbox"/> 1.16 Fees ( Filing ) <input type="checkbox"/> 1.17 Fees ( Processing Ext. of time ) <input type="checkbox"/> 1.18 Fees ( Issue ) <input type="checkbox"/> Other _____ <input type="checkbox"/> Credit		

Reexan



UNITED STATES PATENT AND TRADEMARK OFFICE

UNITED STATES DEPARTMENT OF COMMERCE  
United States Patent and Trademark Office  
Address: COMMISSIONER FOR PATENTS  
P.O. Box 1450  
Alexandria, Virginia 22313-1450  
www.uspto.gov

APPLICATION NO.	FILING DATE	FIRST NAMED INVENTOR	ATTORNEY DOCKET NO.	CONFIRMATION NO.
90/013,252	05/22/2014	5,954,781		9999

7590 06/04/2014  
 MICHAEL S. BUSH  
 HAYNES AND BOONE LLP  
 3100 NATIONSBANK PLAZA  
 901 MAIN STREET  
 DALLAS, TX 75202-3789



EXAMINER

ENGLAND, DAVID E

ART UNIT	PAPER NUMBER
----------	--------------

3992

MAIL DATE	DELIVERY MODE
-----------	---------------

06/04/2014

PAPER

Please find below and/or attached an Office communication concerning this application or proceeding.

The time period for reply, if any, is set in the attached communication.



UNITED STATES PATENT AND TRADEMARK OFFICE



Commissioner for Patents  
United States Patents and Trademark Office  
P.O. Box 1450  
Alexandria, VA 22313-1450  
www.uspto.gov

THIRD PARTY REQUESTER'S CORRESPONDENCE ADDRESS  
KENYON & KENYON LLP  
ONE BROADWAY  
NEW YORK, NY 10004

Date: **MAILED**

**JUN 04 2014**

**CENTRAL REEXAMINATION UNIT**

**EX PARTE REEXAMINATION COMMUNICATION TRANSMITTAL FORM**

REEXAMINATION CONTROL NO. : 90013252  
PATENT NO. : 5954781  
ART UNIT : 3993

Enclosed is a copy of the latest communication from the United States Patent and Trademark Office in the above identified ex parte reexamination proceeding (37 CFR 1.550(f)).

Where this copy is supplied after the reply by requester, 37 CFR 1.535, or the time for filing a reply has passed, no submission on behalf of the ex parte reexamination requester will be acknowledged or considered (37 CFR 1.550(g)).



<b>Ex Parte Reexamination Interview Summary – Pilot Program for Waiver of Patent Owner's Statement</b>	Control No.	Patent Under Reexamination is Requested
	90/013,252	5,954,781
	Examiner	Art Unit
	England, David	3992

-- The MAILING DATE of this communication appears on the cover sheet with the correspondence address. --

**All participants (USPTO official and patent owner):**

- (1) Andrew Lowes (Firm no longer the attorney of record)
- (2) Renee Preston, CRU Paralegal



- (3)
- (4)

Date of Telephonic Interview: 06/04/2014.

**A. The USPTO official requested waiver of the patent owner's statement pursuant to the pilot program for waiver of patent owner's statement in ex parte reexamination proceedings.\***

- The patent owner **agreed** to waive its right to file a patent owner's statement under 35 U.S.C. 304 in the event reexamination is ordered for the above-identified patent.
- The patent owner **did not agree** to waive its right to file a patent owner's statement under 35 U.S.C. 304 at this time.
- USPTO personnel were unable to reach the patent owner.\*\*

**B. The Patent Owner of record telephoned the Office and indicated they would like to participate in the pilot program for waiver of patent owner's statement in ex parte reexamination proceedings.\***

- The Patent owner of record telephoned the Office and **agreed** to waive its right to file a patent owner's statement under 35 U.S.C. 304 in the event reexamination is ordered for the above-identified patent.

The patent owner is not required to file a written statement of this telephone communication under 37 CFR 1.560(b) or otherwise. However, any disagreement as to this interview summary must be brought to the immediate attention of the USPTO, and no later than one month from the mailing date of this interview summary. Extensions of time are governed by 37 CFR 1.550(c).

\*For more information regarding this pilot program, see *Pilot Program for Waiver of Patent Owner's Statement in Ex Parte Reexamination Proceedings*, 75 Fed. Reg. 47269 (August 5, 2010), available on the USPTO Web site at <http://www.uspto.gov/patents/law/notices/2010.jsp>.

\*\*The patent owner may contact the USPTO personnel at (571) 272-7705 or at the telephone number provided below if the patent owner decides to waive the right to file a patent owner's statement under 35 U.S.C. 304.

Renee Preston  (571) 272-7705  
Signature and telephone number of the USPTO official, who contacted, was contacted by, or attempted to contact the patent owner.

cc: Requester (if third party requester)

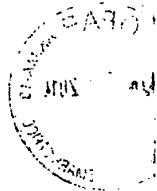

Organization \_\_\_\_\_ Bldg./Room \_\_\_\_\_  
**UNITED STATES PATENT AND TRADEMARK OFFICE**  
 P.O. Box 1450  
 Alexandria, VA. 22313-1450  
 If Undeliverable Return In Ten Days  
 \_\_\_\_\_  
 Official Business  
 Penalty For Private Use, \$300

AN EQUAL OPPORTUNITY EMPLOYER

UNITED STATES POSTAGE  
**\$ 00.48<sup>0</sup>**  
 02 1M JUN 05 2014  
 0008003330 MAILED FROM ZIP CODE 22206

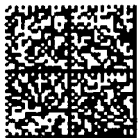

**RECEIVED**  
 JUN 16 2014  
 USPTO MAIL CENTER

NIXIE 750 DE 1009 0005/12/14  
 RETURN TO SENDER  
 ATTEMPTED - NOT KNOWN  
 UNABLE TO FORWARD  
 8C: 22313145050 \*0217-07492-05-41  
 223131450  
 7520269732 0003



UNITED STATES PATENT AND TRADEMARK OFFICE

ITW  
Reexam

UNITED STATES DEPARTMENT OF COMMERCE  
United States Patent and Trademark Office  
Address: COMMISSIONER FOR PATENTS  
P.O. Box 1450  
Alexandria, Virginia 22313-1450  
www.uspto.gov

REEEXAM CONTROL NUMBER	FILING OR 371 (c) DATE	PATENT NUMBER
90/013,252	05/22/2014	5954781

MICHAEL S. BUSH  
HAYNES AND BOONE LLP  
3100 NATIONSBANK PLAZA  
901 MAIN STREET  
DALLAS, TX 75202-3789



CONFIRMATION NO. 9999  
REEEXAM ASSIGNMENT NOTICE



Date Mailed: 05/23/2014

**NOTICE OF ASSIGNMENT OF REEXAMINATION REQUEST**

The above-identified request for reexamination has been assigned to Art Unit 3993. All future correspondence to the proceeding should be identified by the control number listed above and directed to the assigned Art Unit.

A copy of this Notice is being sent to the latest attorney or agent of record in the patent file or to all owners of record. (See 37 CFR 1.33(c)). If the addressee is not, or does not represent, the current owner, he or she is required to forward all communications regarding this proceeding to the current owner(s). An attorney or agent receiving this communication who does not represent the current owner(s) may wish to seek to withdraw pursuant to 37 CFR 1.36 in order to avoid receiving future communications. If the address of the current owner(s) is unknown, this communication should be returned within the request to withdraw pursuant to Section 1.36.

**NOTICE OF USPTO EX PARTE REEXAMINATION PATENT OWNER STATEMENT WAIVER PROGRAM**

The USPTO has implemented a pilot program where, after a reexamination proceeding has been granted a filing date and before the examiner begins his or her review, the patent owner may orally waive the right to file a patent owner's statement. See "Pilot Program for Waiver of Patent Owner's Statement in Ex Parte Reexamination Proceedings," 75 FR 47269 (August 5, 2010). One goal of the pilot program is to reduce the pendency of reexamination proceedings and improve the efficiency of the reexamination process.

Ordinarily when ex parte reexamination is ordered, the USPTO must wait until after the receipt of the patent owner's statement and the third party requester's reply, or after the expiration of the time period for filing the statement and reply (a period that can be as long as 5 to 6 months), before mailing a first determination of patentability. The USPTO's first determination of patentability is usually a first Office action on the merits or a Notice of Intent to Issue Reexamination Certificate (NIRC).

**Under the pilot program, the patent owner's oral waiver allows the USPTO to act on the first determination of patentability immediately after determining that reexamination will be ordered, and in a suitable case issue the reexamination order and the first determination of patentability (which could be a NIRC if the claims under reexamination are confirmed) at the same time.**

**Benefits to the Patent Owner for participating in this pilot program include reduction in pendency.**

To participate in this pilot program, Patent Owners may contact the USPTO's Central Reexamination Unit (CRU) at 571-272-7705. The USPTO will make the oral waiver of record in the reexamination file in an interview summary and a copy will be mailed to the patent owner and any third party requester.

cc: Third Party Requester(if any)  
KENYON & KENYON LLP  
ONE BROADWAY  
NEW YORK, NY 10004

/jawhitfield/

Legal Instruments Examiner  
Central Reexamination Unit 571-272-7705; FAX No. 571-273-9900



UNITED STATES PATENT AND TRADEMARK OFFICE

UNITED STATES DEPARTMENT OF COMMERCE  
United States Patent and Trademark Office  
Address: COMMISSIONER FOR PATENTS  
P.O. Box 1450  
Alexandria, Virginia 22313-1450  
www.uspto.gov

REEXAM CONTROL NUMBER	FILING OR 371 (c) DATE	PATENT NUMBER
90/013,252	05/22/2014	5954781

KENYON & KENYON LLP  
ONE BROADWAY  
NEW YORK, NY 10004



**CONFIRMATION NO. 9999  
REEXAMINATION REQUEST  
NOTICE**



0000000068636830

Date Mailed: 05/23/2014

**NOTICE OF REEXAMINATION REQUEST FILING DATE**

*(Third Party Requester)*

Requester is hereby notified that the filing date of the request for reexamination is 05/22/2014, the date that the filing requirements of 37 CFR § 1.510 were received.

A decision on the request for reexamination will be mailed within three months from the filing date of the request for reexamination. (See 37 CFR 1.515(a)).

A copy of the Notice is being sent to the person identified by the requester as the patent owner. Further patent owner correspondence will be the latest attorney or agent of record in the patent file. (See 37 CFR 1.33). Any paper filed should include a reference to the present request for reexamination (by Reexamination Control Number).

cc: Patent Owner  
MICHAEL S. BUSH  
HAYNES AND BOONE LLP  
3100 NATIONSBANK PLAZA  
901 MAIN STREET  
DALLAS, TX 75202-3789

/jawhitfield/

Legal Instruments Examiner  
Central Reexamination Unit 571-272-7705; FAX No. 571-273-9900

Organization \_\_\_\_\_ Bldg/Room \_\_\_\_\_  
United States Patent and Trademark Office  
P.O. Box 1450  
Alexandria, VA. 22313-1450  
If Undeliverable Return in Ten-Day \_\_\_\_\_

OFFICIAL BUSINESS  
PENALTY FOR PRIVATE USE, \$300

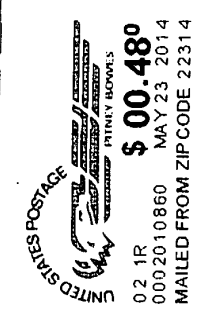

AN EQUAL OPPORTUNITY EMPLOYER

**RECEIVED**  
JUN 13 2014  
USPTO MAIL CENTER

NIXIE 750 DE 1009 0006/10/14  
RETURN TO SENDER  
ATTEMPTED - NOT KNOWN  
UNABLE TO FORWARD  
BC: 22313145050 \*1992-09072-23-03

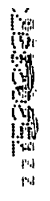



UNITED STATES PATENT AND TRADEMARK OFFICE

UNITED STATES DEPARTMENT OF COMMERCE  
United States Patent and Trademark Office  
Address: COMMISSIONER FOR PATENTS  
P.O. Box 1450  
Alexandria, Virginia 22313-1450  
www.uspto.gov

APPLICATION NO.	FILING DATE	FIRST NAMED INVENTOR	ATTORNEY DOCKET NO.	CONFIRMATION NO.
90/013,252	05/22/2014	5,954,781		9999

7590 06/04/2014  
 MICHAEL S. BUSH  
 HAYNES AND BOONE LLP  
 3100 NATIONSBANK PLAZA  
 901 MAIN STREET  
 DALLAS, TX 75202-3789

EXAMINER

ENGLAND, DAVID E

ART UNIT	PAPER NUMBER
----------	--------------

3992

MAIL DATE	DELIVERY MODE
-----------	---------------

06/04/2014

PAPER

**Please find below and/or attached an Office communication concerning this application or proceeding.**

The time period for reply, if any, is set in the attached communication.



UNITED STATES PATENT AND TRADEMARK OFFICE

---

Commissioner for Patents  
United States Patents and Trademark Office  
P.O. Box 1450  
Alexandria, VA 22313-1450  
www.uspto.gov

THIRD PARTY REQUESTER'S CORRESPONDENCE ADDRESS  
KENYON & KENYON LLP  
ONE BROADWAY  
NEW YORK, NY 10004

MAILED  
Date:  
JUN 04 2014

CENTRAL REEXAMINATION UNIT

**EX PARTE REEXAMINATION COMMUNICATION TRANSMITTAL FORM**

REEXAMINATION CONTROL NO. : 90013252  
PATENT NO. : 5954781  
ART UNIT : 3993

Enclosed is a copy of the latest communication from the United States Patent and Trademark Office in the above identified ex parte reexamination proceeding (37 CFR 1.550(f)).

Where this copy is supplied after the reply by requester, 37 CFR 1.535, or the time for filing a reply has passed, no submission on behalf of the ex parte reexamination requester will be acknowledged or considered (37 CFR 1.550(g)).

---

<b>Ex Parte Reexamination Interview Summary – Pilot Program for Waiver of Patent Owner's Statement</b>	Control No.	Patent Under Reexamination is Requested
	90/013,252	5,954,781
	Examiner	Art Unit
	England, David	3992

-- The MAILING DATE of this communication appears on the cover sheet with the correspondence address. --

**All participants (USPTO official and patent owner):**

- (1) Andrew Lowes (Firm no longer the attorney of record) (3)
- (2) Renee Preston, CRU Paralegal (4)

Date of Telephonic Interview: 06/04/2014.

**A. The USPTO official requested waiver of the patent owner's statement pursuant to the pilot program for waiver of patent owner's statement in ex parte reexamination proceedings.\***

- The patent owner **agreed** to waive its right to file a patent owner's statement under 35 U.S.C. 304 in the event reexamination is ordered for the above-identified patent.
- The patent owner **did not agree** to waive its right to file a patent owner's statement under 35 U.S.C. 304 at this time.
- USPTO personnel were unable to reach the patent owner.\*\*

**B. The Patent Owner of record telephoned the Office and indicated they would like to participate in the pilot program for waiver of patent owner's statement in ex parte reexamination proceedings.\***

- The Patent owner of record telephoned the Office and **agreed** to waive its right to file a patent owner's statement under 35 U.S.C. 304 in the event reexamination is ordered for the above-identified patent.

The patent owner is not required to file a written statement of this telephone communication under 37 CFR 1.560(b) or otherwise. However, any disagreement as to this interview summary must be brought to the immediate attention of the USPTO, and no later than one month from the mailing date of this interview summary. Extensions of time are governed by 37 CFR 1.550(c).

\*For more information regarding this pilot program, see *Pilot Program for Waiver of Patent Owner's Statement in Ex Parte Reexamination Proceedings*, 75 Fed. Reg. 47269 (August 5, 2010), available on the USPTO Web site at <http://www.uspto.gov/patents/law/notices/2010.jsp>.

\*\*The patent owner may contact the USPTO personnel at (571) 272-7705 or at the telephone number provided below if the patent owner decides to waive the right to file a patent owner's statement under 35 U.S.C. 304.

Renee Preston  (571) 272-7705  
Signature and telephone number of the USPTO official, who contacted, was contacted by, or attempted to contact the patent owner.

cc: Requester (if third party requester)





UNITED STATES PATENT AND TRADEMARK OFFICE

UNITED STATES DEPARTMENT OF COMMERCE
United States Patent and Trademark Office
Address: COMMISSIONER FOR PATENTS
P.O. Box 1450
Alexandria, Virginia 22313-1450
www.uspto.gov

Table with 3 columns: REEXAM CONTROL NUMBER (90/013,252), FILING OR 371 (c) DATE (05/22/2014), PATENT NUMBER (5954781)

MICHAEL S. BUSH
HAYNES AND BOONE LLP
3100 NATIONSBANK PLAZA
901 MAIN STREET
DALLAS, TX 75202-3789

CONFIRMATION NO. 9999
REEXAM ASSIGNMENT NOTICE



Date Mailed: 05/23/2014

NOTICE OF ASSIGNMENT OF REEXAMINATION REQUEST

The above-identified request for reexamination has been assigned to Art Unit 3993. All future correspondence to the proceeding should be identified by the control number listed above and directed to the assigned Art Unit.

A copy of this Notice is being sent to the latest attorney or agent of record in the patent file or to all owners of record. (See 37 CFR 1.33(c)). If the addressee is not, or does not represent, the current owner, he or she is required to forward all communications regarding this proceeding to the current owner(s). An attorney or agent receiving this communication who does not represent the current owner(s) may wish to seek to withdraw pursuant to 37 CFR 1.36 in order to avoid receiving future communications. If the address of the current owner(s) is unknown, this communication should be returned within the request to withdraw pursuant to Section 1.36.

NOTICE OF USPTO EX PARTE REEXAMINATION PATENT OWNER STATEMENT WAIVER PROGRAM

The USPTO has implemented a pilot program where, after a reexamination proceeding has been granted a filing date and before the examiner begins his or her review, the patent owner may orally waive the right to file a patent owner's statement. See "Pilot Program for Waiver of Patent Owner's Statement in Ex Parte Reexamination Proceedings," 75 FR 47269 (August 5, 2010). One goal of the pilot program is to reduce the pendency of reexamination proceedings and improve the efficiency of the reexamination process.

Ordinarily when ex parte reexamination is ordered, the USPTO must wait until after the receipt of the patent owner's statement and the third party requester's reply, or after the expiration of the time period for filing the statement and reply (a period that can be as long as 5 to 6 months), before mailing a first determination of patentability. The USPTO's first determination of patentability is usually a first Office action on the merits or a Notice of Intent to Issue Reexamination Certificate (NIRC).

Under the pilot program, the patent owner's oral waiver allows the USPTO to act on the first determination of patentability immediately after determining that reexamination will be ordered, and in a suitable case issue the reexamination order and the first determination of patentability (which could be a NIRC if the claims under reexamination are confirmed) at the same time.

Benefits to the Patent Owner for participating in this pilot program include reduction in pendency.

To participate in this pilot program, Patent Owners may contact the USPTO's Central Reexamination Unit (CRU) at 571-272-7705. The USPTO will make the oral waiver of record in the reexamination file in an interview summary and a copy will be mailed to the patent owner and any third party requester.

cc: Third Party Requester(if any)
KENYON & KENYON LLP
ONE BROADWAY
NEW YORK, NY 10004

/jawhitfield/

Legal Instruments Examiner
Central Reexamination Unit 571-272-7705; FAX No. 571-273-9900



UNITED STATES PATENT AND TRADEMARK OFFICE

UNITED STATES DEPARTMENT OF COMMERCE  
United States Patent and Trademark Office  
Address: COMMISSIONER FOR PATENTS  
P.O. Box 1450  
Alexandria, Virginia 22313-1450  
www.uspto.gov

REEXAM CONTROL NUMBER	FILING OR 371 (c) DATE	PATENT NUMBER
90/013,252	05/22/2014	5954781

KENYON & KENYON LLP  
ONE BROADWAY  
NEW YORK, NY 10004

**CONFIRMATION NO. 9999**  
**REEXAMINATION REQUEST**  
**NOTICE**



Date Mailed: 05/23/2014

**NOTICE OF REEXAMINATION REQUEST FILING DATE**

*(Third Party Requester)*

Requester is hereby notified that the filing date of the request for reexamination is 05/22/2014, the date that the filing requirements of 37 CFR § 1.510 were received.

A decision on the request for reexamination will be mailed within three months from the filing date of the request for reexamination. (See 37 CFR 1.515(a)).

A copy of the Notice is being sent to the person identified by the requester as the patent owner. Further patent owner correspondence will be the latest attorney or agent of record in the patent file. (See 37 CFR 1.33). Any paper filed should include a reference to the present request for reexamination (by Reexamination Control Number).

cc: Patent Owner  
MICHAEL S. BUSH  
HAYNES AND BOONE LLP  
3100 NATIONSBANK PLAZA  
901 MAIN STREET  
DALLAS, TX 75202-3789

/jawhitfield/

\_\_\_\_\_  
Legal Instruments Examiner  
Central Reexamination Unit 571-272-7705; FAX No. 571-273-9900

# Patent Assignment Abstract of Title

## Total Assignments: 3

**Application #:** 08813270    **Filing Dt:** 03/10/1997    **Patent #:** 5954781    **Issue Dt:** 09/21/1999  
**PCT #:** NONE    **Publication #:** NONE    **Pub Dt:**  
**Inventors:** HARVEY SLEPIAN, LORAN SUTTON  
**Title:** METHOD AND APPARATUS FOR OPTIMIZING VEHICLE OPERATION

## Assignment: 1

<b>Reel/Frame:</b> <u>008435 / 0064</u>	<b>Received:</b> 04/14/1997	<b>Recorded:</b> 03/10/1997	<b>Mailed:</b> 05/22/1997	<b>Pages:</b> 4
---	-----------------------------	-----------------------------	---------------------------	-----------------

**Conveyance:** ASSIGNMENT OF ASSIGNORS INTEREST (SEE DOCUMENT FOR DETAILS).

**Assignors:** SLEPIAN, HARVEY    **Exec Dt:** 03/03/1997  
SUTTON, LORAN    **Exec Dt:** 03/03/1997

**Assignee:** TAS DISTRIBUTING CO., INC.  
806 W. PIONEER PARKWAY  
PEORIA, ILLINOIS 61615

**Correspondent:** HARRIS, TUCKER & HARDIN, P.C.  
MICHAEL S. BUSH  
ONE GALLERIA TOWER  
13355 NOEL ROAD, SUITE 2100  
DALLAS, TX 75240-6604

## Assignment: 2

<b>Reel/Frame:</b> <u>031635 / 0364</u>	<b>Received:</b> 11/20/2013	<b>Recorded:</b> 11/20/2013	<b>Mailed:</b> 11/21/2013	<b>Pages:</b> 5
---	-----------------------------	-----------------------------	---------------------------	-----------------

**Conveyance:** ASSIGNMENT OF ASSIGNORS INTEREST (SEE DOCUMENT FOR DETAILS).

**Assignor:** TAS DISTRIBUTING CO., INC    **Exec Dt:** 08/20/2013

**Assignee:** VELOCITY PATENTS LLC  
350 N. ST. PAUL STREET  
SUITE 2900  
DALLAS, TEXAS 75201

**Correspondent:** RICHARDS PATENT LAW P.C.  
233 S. WACKER DR.  
84TH FL  
CHICAGO, IL 60622

## Assignment: 3

<b>Reel/Frame:</b> <u>031635 / 0376</u>	<b>Received:</b> 11/20/2013	<b>Recorded:</b> 11/20/2013	<b>Mailed:</b> 11/21/2013	<b>Pages:</b> 4
---	-----------------------------	-----------------------------	---------------------------	-----------------

**Conveyance:** ASSIGNMENT OF ASSIGNORS INTEREST (SEE DOCUMENT FOR DETAILS).

**Assignor:** VELOCITY PATENTS LLC    **Exec Dt:** 11/15/2013

**Assignee:** VELOCITY PATENT LLC  
335 LLOYDEN PARK LANE  
ATHERTON, CALIFORNIA 94027

**Correspondent:** RICHARDS PATENT LAW P.C.  
233 S. WACKER DR.  
84TH FL  
CHICAGO, IL 60606

(Also referred to as FORM PTO-1465)

**REQUEST FOR EX PARTE REEXAMINATION TRANSMITTAL FORM**

Address to:

**Mail Stop Ex Parte Reexam**  
**Commissioner for Patents**  
**P.O. Box 1450**  
**Alexandria, VA 22313-1450**

Attorney Docket No.: Date: 

1.  This is a request for *ex parte* reexamination pursuant to 37 CFR 1.510 of patent number 5,954,781 issued September 21, 1999. The request is made by:
  - patent owner.
  - third party requester.
2.  The name and address of the person requesting reexamination is:
 

Volkswagen Group of America, Inc.

2200 Ferdinand Porsche Drive

Herndon, VA 20171
3. Requester claims  small entity (37 CFR 1.27) or  micro entity status (37 CFR 1.29) -- only a patent owner requester can claim micro entity status.
4.  a. A check in the amount of \$ \_\_\_\_\_ is enclosed to cover the reexamination fee, 37 CFR 1.20(c)(1);
- b. The Director is hereby authorized to charge the fee as set forth in 37 CFR 1.20(c)(1) to Deposit Account No. \_\_\_\_\_;
- c. Payment by credit card. Form PTO-2038 is attached; or
- d. Payment made via EFS-Web.
5.  Any refund should be made by  check or  credit to Deposit Account No. 11-0600. 37 CFR 1.26(c). If payment is made by credit card, refund must be to credit card account.
6.  A copy of the patent to be reexamined having a double column format on one side of a separate paper is enclosed. 37 CFR 1.510(b)(4).
7.  CD-ROM or CD-R in duplicate, Computer Program (Appendix) or large table
  - Landscape Table on CD
8.  Nucleotide and/or Amino Acid Sequence Submission  
*If applicable, items a. -- c. are required.*
  - a.  Computer Readable Form (CRF)
  - b. Specification Sequence Listing on:
    - i.  CD-ROM (2 copies) or CD-R (2 copies); or
    - ii.  paper
  - c.  Statements verifying identity of above copies
9.  A copy of any disclaimer, certificate of correction or reexamination certificate issued in the patent is included.
10.  Reexamination of claim(s) 1, 2, 4, 5, 7, 8, 10, 12, 13, 15, and 17-32 is requested.
11.  A copy of every patent or printed publication relied upon is submitted herewith including a listing thereof on Form PTO/SB/08, PTO-1449, or equivalent.
12.  An English language translation of all necessary and pertinent non-English language patents and/or printed publications is included.

(Page 1 of 2)

This collection of information is required by 37 CFR 1.510. The information is required to obtain or retain a benefit by the public which is to file (and by the USPTO to process) an application. Confidentiality is governed by 35 U.S.C. 122 and 37 CFR 1.11 and 1.14. This collection is estimated to take 18 minutes to complete, including gathering, preparing, and submitting the completed application form to the USPTO. Time will vary depending upon the individual case. Any comments on the amount of time you require to complete this form and/or suggestions for reducing this burden, should be sent to the Chief Information Officer, U.S. Patent and Trademark Office, U.S. Department of Commerce, P.O. Box 1450, Alexandria, VA 22313-1450. DO NOT SEND FEES OR COMPLETED FORMS TO THIS ADDRESS. **SEND TO: Mail Stop Ex Parte Reexam, Commissioner for Patents, P.O. Box 1450, Alexandria, VA 22313-1450.**

*If you need assistance in completing the form, call 1-800-PTO-9199 and select option 2.*

13.  The attached detailed request includes at least the following items:
- a. A statement identifying each substantial new question of patentability based on prior patents and printed publications. 37 CFR 1.510(b)(1).
  - b. An identification of every claim for which reexamination is requested, and a detailed explanation of the pertinency and manner of applying the cited art to every claim for which reexamination is requested. 37 CFR 1.510(b)(2).
14.  A proposed amendment is included (only where the patent owner is the requester). 37 CFR 1.510(e).
15.  a. It is certified that a copy of this request (if filed by other than the patent owner) has been served in its entirety on the patent owner as provided in 37 CFR 1.33(c).  
 The name and address of the party served and the date of service are:  
Michael S. Bush, Haynes & Boone LLP  
3100 Nationsbank Plaza, 901 Main Street, Dallas, TX 75202-3789  
 Date of Service: May 22, 2014; or
- b. A duplicate copy is enclosed since service on patent owner was not possible. An explanation of the efforts made to serve patent owner is attached. See MPEP § 2220.

16. Correspondence Address: Direct all communication about the reexamination to:

The address associated with Customer Number: 26646

OR

Firm or Individual Name \_\_\_\_\_

Address \_\_\_\_\_

City	State	Zip
Country		
Telephone	Email	

17.  The patent is currently the subject of the following concurrent proceeding(s):
- a. Copending reissue Application No. \_\_\_\_\_
  - b. Copending reexamination Control No. \_\_\_\_\_
  - c. Copending Interference No. \_\_\_\_\_
  - d. Copending litigation styled: Please see attached continuation sheet.

**WARNING: Information on this form may become public. Credit card information should not be included on this form. Provide credit card information and authorization on PTO-2038.**

/Clifford A. Ulrich/ May 22, 2014  
 Authorized Signature Date

Clifford A. Ulrich 42194  For Patent Owner Requester  
 Typed/Printed Name Registration No.  For Third Party Requester

## Privacy Act Statement

The **Privacy Act of 1974 (P.L. 93-579)** requires that you be given certain information in connection with your submission of the attached form related to a patent application or patent. Accordingly, pursuant to the requirements of the Act, please be advised that: (1) the general authority for the collection of this information is 35 U.S.C. 2(b)(2); (2) furnishing of the information solicited is voluntary; and (3) the principal purpose for which the information is used by the U.S. Patent and Trademark Office is to process and/or examine your submission related to a patent application or patent. If you do not furnish the requested information, the U.S. Patent and Trademark Office may not be able to process and/or examine your submission, which may result in termination of proceedings or abandonment of the application or expiration of the patent.

The information provided by you in this form will be subject to the following routine uses:

1. The information on this form will be treated confidentially to the extent allowed under the Freedom of Information Act (5 U.S.C. 552) and the Privacy Act (5 U.S.C. 552a). Records from this system of records may be disclosed to the Department of Justice to determine whether disclosure of these records is required by the Freedom of Information Act.
2. A record from this system of records may be disclosed, as a routine use, in the course of presenting evidence to a court, magistrate, or administrative tribunal, including disclosures to opposing counsel in the course of settlement negotiations.
3. A record in this system of records may be disclosed, as a routine use, to a Member of Congress submitting a request involving an individual, to whom the record pertains, when the individual has requested assistance from the Member with respect to the subject matter of the record.
4. A record in this system of records may be disclosed, as a routine use, to a contractor of the Agency having need for the information in order to perform a contract. Recipients of information shall be required to comply with the requirements of the Privacy Act of 1974, as amended, pursuant to 5 U.S.C. 552a(m).
5. A record related to an International Application filed under the Patent Cooperation Treaty in this system of records may be disclosed, as a routine use, to the International Bureau of the World Intellectual Property Organization, pursuant to the Patent Cooperation Treaty.
6. A record in this system of records may be disclosed, as a routine use, to another federal agency for purposes of National Security review (35 U.S.C. 181) and for review pursuant to the Atomic Energy Act (42 U.S.C. 218(c)).
7. A record from this system of records may be disclosed, as a routine use, to the Administrator, General Services, or his/her designee, during an inspection of records conducted by GSA as part of that agency's responsibility to recommend improvements in records management practices and programs, under authority of 44 U.S.C. 2904 and 2906. Such disclosure shall be made in accordance with the GSA regulations governing inspection of records for this purpose, and any other relevant (*i.e.*, GSA or Commerce) directive. Such disclosure shall not be used to make determinations about individuals.
8. A record from this system of records may be disclosed, as a routine use, to the public after either publication of the application pursuant to 35 U.S.C. 122(b) or issuance of a patent pursuant to 35 U.S.C. 151. Further, a record may be disclosed, subject to the limitations of 37 CFR 1.14, as a routine use, to the public if the record was filed in an application which became abandoned or in which the proceedings were terminated and which application is referenced by either a published application, an application open to public inspection or an issued patent.
9. A record from this system of records may be disclosed, as a routine use, to a Federal, State, or local law enforcement agency, if the USPTO becomes aware of a violation or potential violation of law or regulation.

**CONTINUATION SHEET OF PAGE 2 OF FORM PTO/SB/57**

17d. Copending litigation styled:

*VELOCITY PATENT LLC v. AUDI OF AMERICA, INC.*, Case No. 1:13-cv-08418-JBG (N.D. Ill.)

*VELOCITY PATENT LLC v. MERCEDES-BENZ USA, LLC*, Case No. 1:13-cv-08413-JWD (N.D. Ill.)

*VELOCITY PATENT LLC v. BMW OF NORTH AMERICA, LLC*, Case No. 1:13-cv-08416-JWD (N.D. Ill.)

*VELOCITY PATENT LLC v. CHRYSLER GROUP LLC*, Case No. 1:13-cv-08419-JWD (N.D. Ill.)

*VELOCITY PATENT LLC v. JAGUAR LAND ROVER NORTH AMERICA, LLC*, Case No. 1:13-cv-08421-JWD (N.D. Ill.)

**IN THE UNITED STATES PATENT AND TRADEMARK OFFICE**

In Re Patent of : Harvey Slepian, et al.  
Patent No. : 5,954,781  
Issued : Sep. 21, 1999  
Title : METHOD AND APPARATUS FOR OPTIMIZING  
VEHICLE OPERATION  
Application Serial No. : 08/813,270  
Filed : Mar. 10, 1997  
Requester : Volkswagen Group of America, Inc.

**VIA EFS-WEB**

Mail Stop *Ex Parte* Reexam  
Commissioner for Patents  
P.O. Box 1450  
Alexandria, Virginia 22313-1450

I hereby certify that this correspondence is being electronically transmitted to the United States Patent and Trademark Office via the Office electronic filing system on <b><u>May 22, 2014</u></b> . Signature: <u>/Helen Tam/</u> Helen Tam
--

**REQUEST FOR *EX PARTE* REEXAMINATION  
OF U.S. PATENT NO. 5,954,781 PURSUANT TO 37 C.F.R. § 1.510**

SIR:

Volkswagen Group of America, Inc. ("Requester" or "VWGoA"), through its undersigned counsel, hereby respectfully requests *ex parte* reexamination of U.S. Patent No. 5,954,781 pursuant to 35 U.S.C. § 302 and the provisions of 37 C.F.R. § 1.510.



**TABLE OF CONTENTS**

I. IDENTIFICATION PURSUANT TO 37 C.F.R. § 1.510(b)(2).....1

II. COPY OF '781 PATENT PURSUANT TO 37 C.F.R. § 1.510(b)(4).....1

III. PROCEEDINGS RELATED TO '781 PATENT .....1

IV. THE '781 PATENT AND ITS PROSECUTION .....2

V. CITATIONS OF PRIOR ART PATENTS AND PRINTED PUBLICATIONS THAT RAISE SUBSTANTIAL NEW QUESTIONS OF PATENTABILITY .....15

VI. STATEMENTS IDENTIFYING EACH SUBSTANTIAL NEW QUESTION OF PATENTABILITY PURSUANT TO 37 C.F.R. § 1.510(b)(1) .....16

VII. DETAILED EXPLANATIONS PURSUANT TO 37 C.F.R. § 1.510(b)(2).....17

    1. Claim 1 is Obvious Under 35 U.S.C. § 103(a) in View of the Combination of Jurgen and Saturn '452 .....18

    2. Claims 1, 7, and 13 are Obvious Under 35 U.S.C. § 103(a) in View of the Combination of Jurgen and Toyota '599 .....23

    3. Claims 1, 7, and 13 are Obvious Under 35 U.S.C. § 103(a) in View of the Combination of Jurgen and Volkswagen '070 .....29

    4. Claims 17–23 and 26 are Obvious Under 35 U.S.C. § 103(a) in View of the Combination of Jurgen, Toyota '599, and Davidian .....36

    5. Claims 17–23 and 26 are Obvious Under 35 U.S.C. § 103(a) in View of the Combination of Jurgen, Volkswagen '070, and Davidian.....44

    6. Claims 17–21 and 23 are Obvious Under 35 U.S.C. § 103(a) in View of the Combination of Jurgen, Saturn '452, and Davidian .....54

    7. Claims 28–30 are Obvious Under 35 U.S.C. § 103(a) in View of the Combination of Jurgen and Nissan '055 .....62

    8. Claims 28–30 are Obvious Under 35 U.S.C. § 103(a) in View of the Combination of Jurgen and Mack '324 .....67

9.	Claims 28–30 are Obvious Under 35 U.S.C. § 103(a) in View of the Combination of Jurgen and GM '753.....	73
10.	Claim 31 is Anticipated Under 35 U.S.C. § 102(b) by Davidian.....	78
11.	Claims 31 and 32 are Obvious Under 35 U.S.C. § 103(a) in View of the Combination of Tonkin and Doi et al.....	80
12.	Claims 2, 4, and 5 are Obvious Under 35 U.S.C. § 103(a) in View of the Combination of Jurgen, Saturn '452, and Chasteen.....	84
13.	Claims 2, 4, 5, 8, 10, 12, and 15 are Obvious Under 35 U.S.C. § 103(a) in View of the Combination of Jurgen, Toyota '599, and Chasteen.....	88
14.	Claims 2, 4, 5, 8, 10, 12, and 15 are Obvious Under 35 U.S.C. § 103(a) in View of the Combination of Jurgen, Volkswagen '070, and Chasteen.....	93
15.	Claim 18 is Obvious Under 35 U.S.C. § 103(a) in View of the Combination of Jurgen, Toyota '599, Davidian, and Tonkin.....	98
16.	Claim 18 is Obvious Under 35 U.S.C. § 103(a) in View of the Combination of Jurgen, Volkswagen '070, Davidian, and Tonkin.....	101
17.	Claim 18 is Obvious Under 35 U.S.C. § 103(a) in View of the Combination of Jurgen, Saturn '452, Davidian, and Tonkin.....	103
18.	Claims 24 and 25 are Obvious Under 35 U.S.C. § 103(a) in View of the Combination of Jurgen, Saturn '452, Davidian and Chasteen.....	105
19.	Claims 24, 25, and 27 are Obvious Under 35 U.S.C. § 103(a) in View of the Combination of Jurgen, Toyota '599, Davidian and Chasteen.....	109
20.	Claims 24, 25, and 27 are Obvious Under 35 U.S.C. § 103(a) in View of the Combination of Jurgen, Volkswagen '070, Davidian and Chasteen.....	114
21.	Claim 32 is Obvious Under 35 U.S.C. § 103(a) in View of the Combination of Davidian and Tonkin.....	119
VIII.	VWGoA's PROPOSED GROUNDS OF REJECTION.....	121
IX.	FEE PURSUANT TO 37 C.F.R. § 1.510(a).....	122

X.	CERTIFICATION PURSUANT TO 37 C.F.R. § 1.510(b)(5) .....	123
XI.	CERTIFICATION PURSUANT TO 37 C.F.R. § 1.510(b)(6) .....	123
XII.	CONCLUSION .....	124

## EXHIBITS

- Exhibit 1 U.S. Patent No. 5,954,781, entitled “Method and Apparatus for Optimizing Vehicle Operation,” issued Sept. 21, 1999, to Harvey Slepian, et al.
- Exhibit 2 “First Amended Complaint for Patent Infringement” filed on January 30, 2014 in *VELOCITY PATENT LLC v. AUDI OF AMERICA, INC.*, Case No. 1:13-cv-08418-JBG (N.D. Ill.)
- Exhibit 3 U.S. Patent No. 4,901,701, issued on February 20, 1990 to Chasteen
- Exhibit 4 U.S. Patent No. 4,631,515, issued on December 23, 1986 to Blee et al.
- Exhibit 5 U.S. Patent No. 5,708,584, filed on September 8, 1995, issued on January 13, 1998 to Doi et al.
- Exhibit 6 Velocity Patent LLC’s Initial Infringement Contentions Pursuant to Local Patent Rule 2.2 to Audi
- Exhibit 7 Velocity Patent LLC’s Initial Infringement Contentions Pursuant to Local Patent Rule 2.2 to Mercedes-Benz
- Exhibit 8 Velocity Patent LLC’s Initial Infringement Contentions Pursuant to Local Patent Rule 2.2 to Chrysler
- Exhibit 9 Velocity Patent LLC’s Initial Infringement Contentions Pursuant to Local Patent Rule 2.2 to Jaguar Land Rover
- Exhibit 10 Listing of Prior Art Patents and Printed Publications that Raise Substantial New Questions of Patentability Affecting the Claims of U.S. Patent No. 5,954,781
- Exhibit 11 “Automotive Electronics Handbook,” published in 1995, by Ronald Jurgen
- Exhibit 12 U.S. Patent No. 5,477,452, issued on December 19, 1995 to Milunas et al.
- Exhibit 13 U.S. Patent No. 4,559,599, issued on December 17, 1985 to Habu et al.
- Exhibit 14 German Patent Application Publication No. 29 26 070, and its corresponding English Translation, published on January 15, 1981
- Exhibit 15 U.S. Patent No. 5,357,438, issued on October 18, 1994 to Davidian
- Exhibit 16 U.S. Patent No. 4,061,055, issued on December 6, 1977 to Iizuka et al.
- Exhibit 17 U.S. Patent No. 5,121,324, issued on June 9, 1992 to Rini et al.
- Exhibit 18 U.S. Patent No. 3,925,753, issued on December 9, 1975 to Auman et al.

Exhibit 19 International Patent Application No. WO 96/02853, published on  
February 1, 1996 to Tonkin

Exhibit 20 Certificate of Service

**I. IDENTIFICATION PURSUANT TO 37 C.F.R. § 1.510(b)(2)**

*Ex parte* reexamination of claims 1, 2, 4, 5, 7, 8, 10, 12, 13, 15, and 17–32 of U.S. Patent No. 5,954,781 (“the ’781 patent”) is requested.

**II. COPY OF ’781 PATENT PURSUANT TO 37 C.F.R. § 1.510(b)(4)**

Pursuant to 37 C.F.R. § 1.510(b)(4), annexed hereto as Exhibit 1 is a copy of the entire ’781 patent including the front face, drawings, specification and claims (in double column format) for which *ex parte* reexamination is requested.

To the best of Requester’s knowledge, as of the date of this request, no disclaimer, certificate of correction, or reexamination certificate has been issued in connection with the ’781 patent.

**III. PROCEEDINGS RELATED TO ’781 PATENT**

Although Requester is not obligated to inform the Office of proceedings related to the ’781 patent, the Office is hereby informed of the following proceedings, which are pending as of the date of this Request, that relate to the ’781 patent:

*VELOCITY PATENT LLC v. AUDI OF AMERICA, INC.*, Case No. 1:13-cv-08418-JBG (N.D. Ill.) – First Amended Complaint Filed on January 30, 2014 (“the *VELOCITY-AUDI* case,” copy annexed hereto as Exhibit 2) naming as defendants Audi of America, Inc. and Audi of America, LLC. Audi of America, Inc. is a d/b/a of Volkswagen Group of America, Inc., which is a wholly owned subsidiary of Volkswagen AG, a publicly-held German corporation.

*VELOCITY PATENT LLC v. MERCEDES-BENZ USA, LLC, et al.*, Case No. 1:13-cv-08413-JWD (N.D. Ill.) – Complaint Filed on November 21, 2013 (“the *VELOCITY-MERCEDES-BENZ* case”).

*VELOCITY PATENT LLC v. BMW OF NORTH AMERICA, LLC, et al.*, Case No. 1:13-cv-08416-JWD (N.D. Ill.) – Complaint Filed on November 21, 2013 (“the *VELOCITY-BMW* case”).

*VELOCITY PATENT LLC v. CHRYSLER GROUP LLC*, Case No. 1:13-cv-08419-JWD (N.D. Ill.) – Complaint Filed on November 21, 2013 (“the *VELOCITY-CHRYSLER* case”).

*VELOCITY PATENT LLC v. JAGUAR LAND ROVER NORTH AMERICA, LLC*, Case No. 1:13-cv-08421-JWD (N.D. Ill.) – Complaint Filed on November 21, 2013 (“the *VELOCITY-JAGUAR* case”).

#### **IV. THE '781 PATENT AND ITS PROSECUTION**

##### **A. The '781 Patent**

The '781 patent is titled “Method and Apparatus for Optimizing Vehicle Operation” and was issued on September 21, 1999 from U.S. Application Serial No. 08/873,270 (“the '270 application”), filed on March 10, 1997.

The '781 patent is generally related to an “[a]pparatus for optimizing operation of an engine-driven vehicle.” Abstract. In describing the background and prior art, the '781 patent states that “[i]t has long been recognized that the improper operation of a vehicle may have many adverse effects.” Col. 1, lines 12–13. For example, according to the '781 patent, “the fuel efficiency of a vehicle may vary dramatically based upon how the vehicle is operated.” Col. 1, lines 13–15. The '781 patent refers specifically to, for example, operating a vehicle at excessive speeds, excessive RPMs, and excessive manifold pressures as leading to reduced fuel economy and increased operating costs. Col. 1, lines 15–18. The increased operating costs may be considerable, especially for the owner or operator of a fleet of vehicles. Against this background, the '781 patent describes a processor subsystem to determine when to issue notifications as to recommended changes in vehicle operation that, when executed by the driver, will optimize vehicle operation.

According to the specification, the system “both notifies the driver of recommended corrections in vehicle operation and, under certain conditions, automatically initiates selected corrective action.” Col. 1, lines 7–10. The '781 patent states that “it would be desirable to provide a system which integrates the ability to issue audible warnings which advise the driver to correct operation of the vehicle in a manner which will enhance the efficient operation thereof with the ability to automatically take corrective action if the vehicle is being operated unsafely.” Col. 1, line 66–col. 2, line 6.

The '781 patent describes three types of circuits for issuing notifications that indicate operating inefficiencies: a shift notification circuit; a fuel overinjection notification circuit; and a vehicle proximity alarm circuit. The shift notification circuit issues a notification that the engine of the vehicle is being operated at an excessive speed, i.e., the shift notification circuit operates as an upshift notification circuit, and/or issues a notification that the engine of the vehicle is being operated at an insufficient speed, i.e., the shift notification circuit operates as a downshift notification circuit. The fuel overinjection notification circuit issues a notification that excessive fuel is being supplied to the engine of the vehicle, and the vehicle proximity alarm circuit issues an alarm when the vehicle is too close to an object.

According to the '781 patent, a series of sensors, including a road speed sensor 18, an RPM sensor 20, a manifold pressure sensor 22, a throttle sensor 24, a windshield wiper sensor 30, and a brake sensor 32, are coupled to a processor subsystem 12 and are periodically polled by the processor subsystem to determine their respective states or levels. Col. 5, line 65–col. 6, line 4. The system 10 includes a memory subsystem 14, which is used to hold information to be utilized by the processor subsystem 12 to determine whether to take corrective actions and/or issue notifications. Col. 6, lines 43–46. Figure 1 of the '781 patent is reproduced below:

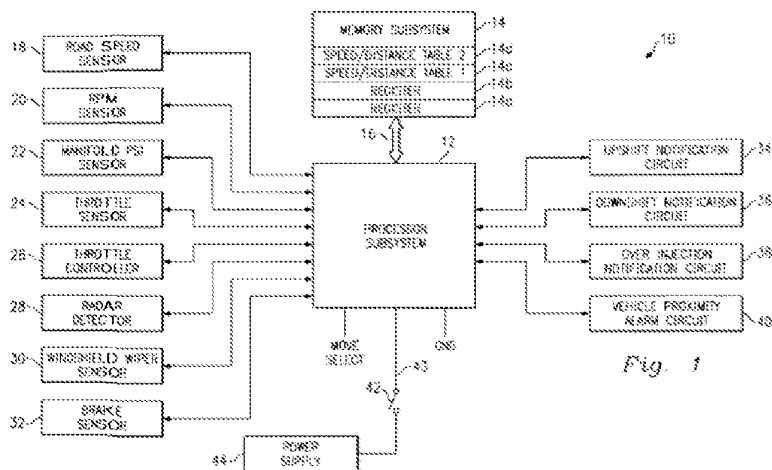

Fig. 1

For example, the processor subsystem 12 determines that the vehicle is being operated unsafely if the speed of the vehicle is such that the stopping distance for the vehicle is greater than the distance separating the vehicle from an object, e.g., a second vehicle, in its path. Col. 9, lines 4–8. As another example, the processor subsystem 12 will notify the driver that, in order to optimize vehicle operation, the amount of fuel being supplied to the engine should be reduced if the processor subsystem 12 determines that too much fuel is being provided to the engine, which is determined based on the vehicle's road speed, throttle position, and manifold pressure. Col. 12, lines 5–14. As a further example, the processor subsystem 12 will issue an audible alert to notify the driver that, in order to optimize vehicle operation, an upshift should be performed, based on the vehicle's engine speed reaching a particular RPM set point. Col. 11, line 45–col. 12, line 4.

Thus, according to the '781 patent, a system is provided for optimizing vehicle operation that combines operator notifications of recommended corrections in vehicle operation with automatic modification of vehicle operation under certain circumstances. Col.



13, lines 36–40. In addition, the driver is advised of certain actions that will enable the vehicle to be operated with greater fuel efficiency. Col. 13, lines 40–44.

**B. Prosecution of the '781 Patent**

As described in more detail below, during prosecution of the '781 patent, the Examiner concluded that upshift notification circuits, downshift notification circuits, and processors that determine when to activation upshift and downshift notification circuits were not taught by the cited prior art.

Claims 1 to 6 and 17 to 25 were allowed because they were amended to include, for example, an upshift notification circuit and a processor that determines when to activate the upshift notification circuit. Therefore, the questions whether substantial new questions of patentability are raised and whether claims 1 to 6 and 17 to 25 are obvious in view of the prior art are reduced to these limitations relating to the upshift notification circuit.<sup>1</sup>

Claims 7 to 12, 26, and 27 were allowed because they were, in effect,<sup>2</sup> amended to include, for example, a downshift notification circuit and a processor that determines when to activate the downshift notification circuit. Therefore, the questions whether substantial new questions of patentability are raised and whether claims 7 to 12, 26, and 27 are obvious in view of the prior art are reduced to these limitations relating to the downshift notification circuit.

Claims 13 to 16 were allowed based on the fact that they include an upshift notification circuit, a downshift notification circuit, and a processor that determines when to activate the upshift and downshift notification circuits. Therefore, the questions whether substantial new questions of patentability are raised and whether claims 13 to 16 are obvious in view of the prior art are reduced to these limitations relating to the upshift and downshift notification circuits.

Regarding claims 28 to 30, which were added during prosecution, the applicant argued that these claims were allowable over the cited prior art based on the fact that they

---

<sup>1</sup> *Graham v. John Deere Co.* 383 U.S. 1 (1966) (“Here, the patentee obtained his patent only by accepting the limitations imposed by the Examiner. The claims were carefully drafted to reflect these limitations and Cook Chemical is not now free to assert a broader view of Scoggin’s invention. The subject matter as a whole reduces, then, to the distinguishing features clearly incorporated into the claims. We now turn to those features.”).

<sup>2</sup> *See, e.g., Honeywell Int’l v. Hamilton Sundstrand Corp.*, 370 F.3d 1131, 1144 (Fed. Cir. 2004) (“[D]ependent c]laims 4, 8, and 19 were rewritten into independent form, and the original independent claims were cancelled, effectively adding the inlet guide vane limitations [of dependent claims 4, 8 and 19] to the claimed invention.”).

claim a fuel overinjection notification circuit and a processor subsystem that determines whether to activate the fuel overinjection notification circuit based on data received from a road speed sensor, a throttle position sensor, and a manifold pressure sensor. Therefore, the questions whether substantial new questions of patentability are raised and whether claims 28 to 30 are obvious in view of the prior art are reduced to these limitations relating to the fuel overinjection notification circuit.

Regarding claims 31 and 32, which were added during prosecution, the applicants argued that these claims were allowable over the prior art based on the fact that they claim a processor subsystem that determines whether to activate a vehicle proximity alarm circuit based on separation distance data received from a radar detector, vehicle speed data received from a road speed sensor, and a vehicle stopping distance table stored in a memory subsystem. Therefore, the questions whether substantial new questions of patentability are raised and whether claims 31 and 32 are obvious in view of the prior art are reduced to these limitations relating to the vehicle proximity alarm circuit.

The '270 application was filed on March 10, 1997 with 32 claims, of which application claims 1, 14, 18, and 27 were the only independent claims. Among these independent claims, application claim 1 included a fuel overinjection circuit, application claim 14 included a fuel overinjection circuit, an upshift notification circuit, and a downshift notification circuit, application claim 18 included a vehicle proximity alarm, and application claim 27 included a fuel overinjection circuit and a vehicle proximity alarm.

In the only Office Action, dated August 6, 1998, application claims 1, 2 and 4 to 6 were rejected as obvious in view of U.S. Patent No. 4,901,701 to Chasteen (copy attached as Exhibit 3), application claim 3 was rejected as obvious in view of the combination of Chasteen and U.S. Patent No. 4,631,515 to Blee et al. (copy attached as Exhibit 4), and application claims 7, 18 to 24, 27, and 28 were rejected as obvious in view of the combination of Chasteen and U.S. Patent No. 5,708,584 to Doi et al. (copy attached as Exhibit 5).

In the Office Action, the Examiner stated that application claims 8 to 13, 25, 26, and 29 to 32 included allowable subject matter. Specifically, the Examiner stated that application claims 8, 25, and 29 included allowable subject matter on the basis that "the prior art fails to disclose an upshift notification circuit coupled to the processor subsystem, the upshift notification circuit issuing a notification that the engine of the vehicle is being operated at an excessive engine speed and the processor determines when to activate the upshift notification circuit." Similarly, the Examiner stated that application claims 11, 26, and 31 included

allowable subject matter on the basis that “the prior art fails to disclose a downshift notification circuit coupled to the processor subsystem, the downshift notification circuit issuing a notification that the engine of the vehicle is being operated at an insufficient engine speed and the processor determines when to activate the downshift notification circuit.” In addition, application claims 14 to 17, which included both an upshift notification circuit and a downshift notification circuit, were allowed on the basis that:

the prior art fails to disclose an upshift notification circuit coupled to the processor subsystem, the upshift notification circuit issuing a notification that the engine of the vehicle is being operated at an excessive engine speed and the processor determines when to activate the upshift notification circuit and a downshift notification circuit coupled to the processor subsystem, the downshift notification circuit issuing a notification that the engine of the vehicle is being operated at an insufficient engine speed and the processor determines when to activate the downshift notification circuit.

In response to this Office Action, the applicant submitted an Amendment on February 8, 1999. Application claim 1 was amended as follows, to add the limitations of claims 4 and 8, including the upshift notification circuit of claim 8:

1. Apparatus for optimizing operation of a vehicle, comprising:

a plurality of sensors coupled to a vehicle having an engine, said plurality of sensors, which collectively monitor operation of said vehicle, including a road speed sensor, an engine speed sensor, a manifold pressure sensor and a throttle position sensor;

a processor subsystem, coupled to each one of said plurality of sensors, to receive data therefrom;

a memory subsystem, coupled to said processor subsystem, said memory subsystem storing therein a manifold pressure set point and present and prior levels for each one of said plurality of sensors;

a fuel overinjection notification circuit coupled to said processor subsystem, said fuel overinjection notification circuit issuing a notification that excessive fuel is being supplied to said engine of said vehicle;

an upshift notification circuit coupled to said processor subsystem, said upshift notification circuit issuing a notification

that said engine of said vehicle is being operated at an excessive speed;

said processor subsystem determining, based upon data received from said plurality of sensors, when to activate said fuel overinjection circuit, and when to activate said upshift notification circuit.

Dependent application claim 11, which included a downshift notification circuit, was rewritten into independent form as follows:

11. Apparatus for optimizing operation of a vehicle, [according to claim 4 and further] comprising:

a plurality of sensors coupled to a vehicle having an engine, said plurality of sensors, which collectively monitor operation of said vehicle, including a road speed sensor, a manifold pressure sensor and a throttle position sensor;

a processor subsystem, coupled to each one of said plurality of sensors, to receive data therefrom;

a memory subsystem, coupled to said processor subsystem, said memory subsystem storing therein a manifold pressure set point and present and prior levels for each one of said plurality of sensors;

a fuel overinjection notification circuit coupled to said processor subsystem, said fuel overinjection notification circuit issuing a notification that excessive fuel is being supplied to said engine of said vehicle;

a downshift notification circuit coupled to said processor subsystem, said downshift notification circuit issuing a notification that said engine of said vehicle is being operated at an insufficient engine speed; and

said processor subsystem determining, based upon data received from said plurality of sensors, when to activate said fuel overinjection circuit and when to activate said downshift notification circuit.

Application claim 18 was amended as follows, to add the limitations of dependent claims 23 to 25, including the upshift notification circuit of claim 25:

18. Apparatus for optimizing operation of a vehicle, comprising:

a radar detector, said radar detector determining a distance separating a vehicle having an engine and an object in front of said vehicle;

at least one sensor coupled to said vehicle for monitoring operation thereof, said at least one sensor including a road speed sensor, a manifold pressure sensor, a throttle position sensor and an engine speed sensor;

a processor subsystem, coupled to said radar detector and said at least one sensor, to receive data therefrom;

a memory subsystem, coupled to said processor subsystem, said memory subsystem storing a first vehicle speed stopping distance table, a manifold pressure set point, an RPM set point, a [and] present level[s] for each one of said at least one sensor and a prior level for each one of said at least one sensor;

a vehicle proximity alarm circuit coupled to said processor subsystem, said vehicle proximity alarm circuit issuing an alarm that said vehicle is too close to said object;

a fuel overinjection circuit coupled to said processor subsystem, said fuel overinjection circuit issuing a notification that excessive fuel is being supplied to said engine of said vehicle;

an upshift notification circuit coupled to said processor subsystem, said upshift notification circuit issuing a notification that said engine of said vehicle is being operated at an excessive speed;

said processor subsystem determining, based upon data received from said radar detector, said at least one sensor and said memory subsystem, when to activate said vehicle proximity alarm circuit, when to activate said fuel overinjection circuit, and when to activate said upshift notification circuit.

Application claim 27 was amended as follows, to add the limitations of dependent claim 29, including the upshift notification circuit of claim 29:

27. Apparatus for optimizing operation of a vehicle, comprising:

a radar detector, said radar detector determining a distance separating a vehicle having an engine and an object in front of said vehicle;

a plurality of sensors coupled to a vehicle having an engine, said plurality of sensors, which collectively monitor operation

of said vehicle, including a road speed sensor, an engine speed sensor, a manifold pressure sensor and a throttle position sensor;

a processor subsystem, coupled to said radar detector and each one of said plurality of sensors, to receive data therefrom;

a memory subsystem, coupled to said processor subsystem, said memory subsystem storing therein a first vehicle speed/stopping distance table, a manifold pressure set point, an RPM set point, and present and prior levels for each one of said plurality of sensors;

a fuel overinjection notification circuit coupled to said processor subsystem, said fuel overinjection notification circuit issuing a notification that excessive fuel is being supplied to said engine of said vehicle;

an upshift notification circuit coupled to said processor subsystem, said upshift notification circuit issuing a notification that said engine of said vehicle is being operated at an excessive engine speed;

said processor subsystem determining, based upon data received from said plurality of sensors, when to activate said fuel overinjection circuit and when to activate said upshift notification circuit;

a vehicle proximity alarm circuit coupled to said processor subsystem, said vehicle proximity alarm circuit issuing an alarm that said vehicle is too close to said object;

said processor subsystem determining, based upon data received from said radar detector, said at least one sensor and said memory subsystem, when to activate said vehicle proximity alarm circuit.

Dependent application claim 31, which included a downshift notification circuit, was rewritten into independent form as follows:

31. Apparatus for optimizing operation of a vehicle, [according to claim 27 and further] comprising:

a radar detector, said radar detector determining a distance separating a vehicle having an engine and an object in front of said vehicle;

a plurality of sensors coupled to a vehicle having an engine, said plurality of sensors, which collectively monitor operation of said vehicle, including a road speed sensor, and engine speed

sensor, a manifold pressure sensor and a throttle position sensor;

a processor subsystem, coupled to said radar detector and each one of said plurality of sensors, to receive data therefrom;

a memory subsystem, coupled to said processor subsystem, said memory subsystem storing therein a first vehicle speed/stopping distance table, a manifold pressure set point, RPM set point, and present and prior levels for each one of said plurality of sensors;

a fuel overinjection notification circuit coupled to said processor subsystem, said fuel overinjection notification circuit issuing a notification that excessive fuel is being supplied to said engine of said vehicle;

a downshift notification circuit coupled to said processor subsystem, said downshift notification circuit issuing a notification that said engine of said vehicle is being operated at an insufficient engine speed;

said processor subsystem determining, based upon data received from said plurality of sensors, when to activate said fuel overinjection circuit and when to activate said downshift notification circuit;

a vehicle proximity alarm circuit coupled to said processor subsystem, said vehicle proximity alarm circuit issuing an alarm that said vehicle is too close to said object;

said processor subsystem determining, based upon data received from said radar detector, said at least one sensor and said memory subsystem, when to activate said vehicle proximity alarm circuit.

In addition to the foregoing claim amendments, the applicants added new application claims 33 to 38, which are discussed in further detail below.

Regarding the claim amendments, the applicant did not present any substantive arguments against the rejection of claims 1-2, 5, 6, 18 to 24, 27, and 28. Rather, the applicant acknowledged that the claims were merely reformulated to place into allowable form the claims that were indicated to include allowable subject matter.

Regarding the newly presented claims, application claims 34 and 37 were the only independent claims, and these claims as presented in the February 8, 1999 Amendment are reproduced below:

34. Apparatus for optimizing operation of a vehicle, comprising:

a plurality of sensors coupled to a vehicle having an engine, said plurality of sensors, which collectively monitor operation of said vehicle, including a road speed sensor, a manifold pressure sensor and a throttle position sensor;

a processor subsystem, coupled to each one of said plurality of sensors, to receive data therefrom;

a fuel overinjection notification circuit coupled to said processor subsystem, said fuel overinjection notification circuit issuing a notification that excessive fuel is being supplied to said engine of said vehicle;

said processor subsystem determining whether to activate said fuel overinjection notification sensor based upon data received from said road speed sensor, said throttle position sensor and said manifold pressure sensor.

37. Apparatus for optimizing operation of a vehicle, comprising:

a radar detector, said radar detector determining a distance separating a vehicle having an engine and an object in front of said vehicle;

at least one sensor coupled to said vehicle for monitoring operation thereof, said at least one sensor including a road speed sensor;

a processor subsystem, coupled to said radar detector and said at least one sensor, to receive data therefrom;

a memory subsystem, coupled to said processor subsystem, said memory subsystem storing a first vehicle speed/stopping distance table;

a vehicle proximity alarm circuit coupled to said processor subsystem, said vehicle proximity alarm circuit issuing an alarm that said vehicle is too close to said object;

said processor subsystem determining whether to activate said vehicle proximity alarm circuit based upon separation distance data received from said radar detector, vehicle speed data received from said road speed sensor and said first vehicle speed/stopping distance table stored in said memory subsystem.



In the accompanying Remarks, the applicant asserted that application claim 34 is patentable over the prior art by stating:

With respect to Chasteen, the Applicants first note the [sic] Chasteen discloses a system where, in response to certain detected conditions, a CPU issues control commands which modify the operation of an engine. In contrast, Applicants' system merely issues notifications of the determination of a fuel overinjection condition. No corrective action is taken by the system. Applicants' system is superior in that it enables the vehicle to be operated outside of the preferred operating conditions when the vehicle operator deems it necessary. For example, it may be necessary to operate the vehicle in a fuel overinjection mode when performing emergency actions such as rapid accelerations to avoid collisions.

The Applicants further note that, in rejection prior Claim 1 as unpatentable over Chasteen, the Examiner acknowledged that Chasteen "fails to specifically disclose a road speed sensor" and asserted that "it would have been obvious . . . to have a road speed sensor in the system since the speed sensor would help to monitor the operation of the vehicle." Again, the Applicants respectfully disagree. Specifically, as presented in new Claims 34-36, Applicants' claimed apparatus for optimizing operation of a vehicle includes a fuel overinjection notification circuit and a processor subsystem which determines when to activate the fuel overinjection notification circuit. The processor makes that determination based upon data received from specifically recited sensors, including the road speed sensor. Thus, not only does Chasteen fail to teach an apparatus for optimizing vehicle operation which includes a road speed sensor, Chasteen is equally deficient in teaching a processor configured to determine a fuel overinjection condition by analyzing, in combination, road speed, throttle position and manifold pressure level. As Chasteen lacks both a specific sensor and a processor configured to determine a fuel overinjection condition from data collected from that specific sensor in combination with other sensors, the Applicants respectfully submit that Chasteen cannot teach or suggest the apparatus defined by new Claims 34-36.

February 8, 1999 Amendment, at 10-11 (emphasis in original).

In other words, according to the applicant, application claim 34 is allowable because the prior art does not disclose a fuel overinjection notification circuit that is activated based on three sensors: a road speed sensor, a throttle position sensor, and a manifold pressure sensor.

Additionally, the applicant asserted that application claim 37 is patentable over the prior art by stating:

The Applicants respectfully submit that new Claims 37-38, as presented herein, are neither taught nor suggested by the proposed combination of Chasteen and Doi et al. The Examiner properly cited Doi et al. as disclosing a vehicle running mode detection system equipped with a radar detector and an alarm circuit. The Applicants respectfully note, however, that the system disclosed in Doi et al. determines alert conditions relative to the proximity between a vehicle and a forward object based upon changes in the distance separating the vehicle and the forward object. In contrast, Applicants' apparatus for optimizing vehicle operation set forth in Claim 37 includes a processor subsystem configured to activate a vehicle proximity alarm circuit based upon road speed (as determined by a road speed sensor), separation (as determined by a radar detector) and a vehicle speed/stopping distance table stored in a memory subsystem.

Id. at 11-12.

In other words, according to the applicant, application claim 37 is allowable because the prior art does not disclose a vehicle proximity alarm that is activated based upon three parameters: (1) road speed, as determined by a road speed sensor; (2) separation, as determined by a radar detector; and (3) a vehicle speed/stopping distance table stored in a memory subsystem. The applicant did acknowledge, however, that a vehicle proximity alarm that is activated based on separation is disclosed in the prior art: "The Applicants respectfully note, however, that the system disclosed in Doi et al. determines alert conditions relative to the proximity between a vehicle and a forward object based upon changes in the distance separating the vehicle and the forward object."

Thereafter, the Examiner issued a Notice of Allowance, which includes a lengthy statement by the Examiner of the reasons for allowance. Although no specific claims are discussed in the Examiner's statement of reasons for allowance, particular claim language is discussed such the reason that each independent was allowed is apparent.

For example, the Notice of Allowance states that

The prior art fails to disclose an apparatus for optimizing operation of a vehicle and comprising an upshift notification circuit coupled to the processor subsystem, the upshift notification circuit issuing a notification that the engine of the vehicle is being operated at an excessive speed and the processor determines when to activate the upshift notification circuit; and a downshift notification circuit coupled to the processor subsystem, the downshift notification circuit issuing

a notification that the engine of the vehicle is being operated at an insufficient engine speed and the processor determines when to activate the downshift notification circuit.

The Notice of Allowance further states that:

Nor does the prior art disclose [sic] a fuel overinjection notification circuit coupled to the processor subsystem, wherein the fuel overinjection notification circuit issues a notification that excess fuel is being supplied to the engine of the vehicle and the processor subsystem determines whether to activate the fuel overinjection notification circuit based upon data received from the road speed sensor, the throttle position sensor and the manifold sensor.

Additionally, the Notice of Allowance states:

Nor does the prior art disclose [sic] that the processor subsystem determines whether to activate the vehicle proximity alarm circuit based upon separation distance data received from the radar detector, vehicle speed/stopping distance table stored in the memory subsystem.

**V. PATENT OWNER'S INFRINGEMENT CONTENTIONS IN LITIGATIONS INVOLVING THE '781 PATENT**

As stated above, the '781 patent is the subject of related litigations, including the *VELOCITY-AUDI* case, the *VELOCITY-MERCEDES-BENZ* case, the *VELOCITY-BMW* case, the *VELOCITY-CHRYSLER* case, and the *VELOCITY-JAGUAR* case. Attached as Exhibits 6 to 9 are copies of "Velocity Patent LLC's Initial Infringement Contentions Pursuant to Local Patent Rule 2.2," served by the Patent Owner in the *VELOCITY-AUDI* case, the *VELOCITY-MERCEDES-BENZ* case, the *VELOCITY-CHRYSLER* case, and the *VELOCITY-JAGUAR* case, respectively. In these Initial Infringement Contentions, the Patent Owner has asserted (1) that cylinder-on-demand systems, fuel economy messages, and speed warning systems, for example, are functionalities that infringe fuel overinjection notification circuits, (2) that efficiency programs, gearshift indicators that show current and recommended gears, dynamic steering systems, transmission overheating indicators, and gear selection levers in automatic transmissions, for example, are functionalities that infringe upshift and downshift notification

circuits; and (3) that adaptive cruise control systems, braking guard systems, and side assist systems, for example, are functionalities that infringe vehicle proximity alarm circuits.<sup>3</sup>

**VI. CITATIONS OF PRIOR ART PATENTS AND PRINTED PUBLICATIONS THAT RAISE SUBSTANTIAL NEW QUESTIONS OF PATENTABILITY**

Substantial new questions of patentability of claims 1, 2, 4, 5, 7, 8, 10, 12, 13, 15, and 17 to 32 of the '781 patent are raised by the following prior art patents and printed publications. Annexed hereto as Exhibit 10 is a listing of, *inter alia*, the prior art patents and printed publications that raise substantial questions of patentability. Each of the prior art patent and printed publications cited herein constitutes prior art against the '781 patent under 35 U.S.C. § 102(b).

- A. Automotive Electronics Handbook, by Ronald Jurgen ("Jurgen"), published in 1995.
- B. U.S. Patent No. 5,477,452 ("Saturn '452"), issued on December 19, 1995.
- C. U.S. Patent No. 4,559,599 ("Toyota '599"), issued on December 17, 1985.
- D. German Patent Application Publication No. 29 26 070 ("Volkswagen '070"), published on January 15, 1981.
- E. U.S. Patent No. 5,357,438 ("Davidian"), issued on October 18, 1994.
- F. U.S. Patent No. 4,061,055 ("Nissan '055"), issued on December 6, 1977.
- G. U.S. Patent No. 5,121,324 ("Mack '324"), issued on June 9, 1992.
- H. U.S. Patent No. 3,925,753 ("GM '753"), issued on December 9, 1975.
- I. PCT Publication No. WO 96/02853 ("Tonkin"), published on February 1, 1996.

A copy of every prior art patent and printed publication relied upon or referred to herein is submitted herewith as required by 37 C.F.R. § 1.510(b)(3), as follows:

---

<sup>3</sup> Nothing in the present Request should be considered to constitute an agreement, admission, or concession by VWGoA that the claims of the '781 patent cover the systems or vehicles described in the Patent Owner's Initial Infringement Contentions.

- A. A copy of Jurgan is annexed hereto as Exhibit 11.
- B. A copy of Saturn '452 is annexed hereto as Exhibit 12.
- C. A copy of Toyota '599 is annexed hereto as Exhibit 13.
- D. A copy of Volkswagen '070 is annexed hereto as Exhibit 14.
- E. A copy of Davidian is annexed hereto as Exhibit 15.
- F. A copy of Nissan '055 is annexed hereto as Exhibit 16.
- G. A copy of Mack '324 is annexed hereto as Exhibit 17.
- H. A copy of GM '753 is annexed hereto as Exhibit 18.
- I. A copy of Tonkin is annexed hereto as Exhibit 19.

**VII. STATEMENTS IDENTIFYING EACH SUBSTANTIAL NEW  
QUESTION OF PATENTABILITY PURSUANT TO 37 C.F.R. § 1.510(b)(1)**

1. Claim 1 is Obvious Under 35 U.S.C. § 103(a) in View of the Combination of Jurgan and Saturn '452
2. Claims 1, 7, and 13 are Obvious Under 35 U.S.C. § 103(a) in View of the Combination of Jurgan and Toyota '599
3. Claims 1, 7, and 13 are Obvious Under 35 U.S.C. § 103(a) in View of the Combination of Jurgan and Volkswagen '070
4. Claims 17–23 and 26 are Obvious Under 35 U.S.C. § 103(a) in View of the Combination of Jurgan, Toyota '599, and Davidian
5. Claims 17–23 and 26 are Obvious Under 35 U.S.C. § 103(a) in View of the Combination of Jurgan, Volkswagen '070, and Davidian
6. Claims 17–21 and 23 are Obvious Under 35 U.S.C. § 103(a) in View of the Combination of Jurgan, Saturn '452, and Davidian
7. Claims 28–30 are Obvious Under 35 U.S.C. § 103(a) in View of the Combination of Jurgan and Nissan '055
8. Claims 28–30 are Obvious Under 35 U.S.C. § 103(a) in View of the Combination of Jurgan and Mack '324
9. Claims 28–30 are Obvious Under 35 U.S.C. § 103(a) in View of the Combination of Jurgan and GM '753
10. Claim 31 is Anticipated Under 35 U.S.C. § 102(b) by Davidian

11. Claims 31 and 32 are Obvious Under 35 U.S.C. § 103(a) in View of the Combination of Tonkin and Doi et al.
12. Claims 2, 4, and 5 are Obvious Under 35 U.S.C. § 103(a) in View of the Combination of Jurgen, Saturn '452, and Chasteen
13. Claims 2, 4, 5, 8, 10, 12, and 15 are Obvious Under 35 U.S.C. § 103(a) in View of the Combination of Jurgen, Toyota '599, and Chasteen
14. Claims 2, 4, 5, 8, 10, 12, and 15 are Obvious Under 35 U.S.C. § 103(a) in View of the Combination of Jurgen, Volkswagen '070, and Chasteen
15. Claim 18 is Obvious Under 35 U.S.C. § 103(a) in View of the Combination of Jurgen, Toyota '599, Davidian, and Tonkin
16. Claim 18 is Obvious Under 35 U.S.C. § 103(a) in View of the Combination of Jurgen, Volkswagen '070, Davidian, and Tonkin
17. Claim 18 is Obvious Under 35 U.S.C. § 103(a) in View of the Combination of Jurgen, Saturn '452, Davidian, and Tonkin
18. Claims 24 and 25 are Obvious Under 35 U.S.C. § 103(a) in View of the Combination of Jurgen, Saturn '452, Davidian and Chasteen
19. Claims 24, 25, and 27 are Obvious Under 35 U.S.C. § 103(a) in View of the Combination of Jurgen, Toyota '599, Davidian and Chasteen
20. Claims 24, 25, and 27 are Obvious Under 35 U.S.C. § 103(a) in View of the Combination of Jurgen, Volkswagen '070, Davidian and Chasteen
21. Claim 32 is Obvious Under 35 U.S.C. § 103(a) in in View of the combination of Davidian and Tonkin

**DETAILED EXPLANATIONS PURSUANT TO 37 C.F.R. § 1.510(b)(2)**

The following statements are made, pursuant to 37 C.F.R. § 1.510(b)(2), pointing out each substantial new question of patentability based on the prior art patents and printed publications cited above, in accordance with the “broadest reasonable interpretation” standard as set forth in M.P.E.P. § 2258(I)(G).<sup>4</sup>

As set forth in detail below, the foregoing prior art patents and printed publications would have been considered important by a reasonable Examiner in deciding whether to allow claims 1, 2, 4, 5, 7, 8, 10, 12, 13, 15, and 17 to 32 of the '781 patent. Therefore, these prior art patents and printed publications raise substantial new questions of patentability.

---

<sup>4</sup> “During reexamination, claims are given their broadest reasonable interpretation consistent with the specification and limitations in the specification are not read into the claims.”

Pursuant to 37 C.F.R. § 1.510(b)(2), a detailed explanation of the pertinence and manner of applying the cited prior art patents and printed publications to every claim for which reexamination is requested is set forth below with reference to the appended charts.

The following detailed explanation is informed by the prosecution history, as set forth above. To briefly summarize, the Examiner in the original prosecution concluded that the prior art failed to teach or suggest upshift or downshift notification circuits for claims 1, 2, 4, 5, 7, 8, 10, 12, 13, 15, and 17 to 27. Because the prosecution history focused on the upshift and/or downshift notification circuits, and because the prior art discussed herein discloses these circuits, substantial new questions of patentability affecting claims 1, 7, 13, 17, 23, 26 are raised by the prior art discussed herein.

With respect to claims 28 to 30, the applicant in the original prosecution emphasized that the prior art failed to teach a fuel overinjection notification circuit that is activated based on three sensors: a road speed sensor, a throttle position sensor, and a manifold pressure sensor. Because the prosecution history focused on a fuel overinjection notification circuit activated based on these three sensors, and because the prior art disclosed herein discloses a fuel overinjection notification circuit activated based on these three sensors, substantial new questions of patentability affecting claims 28 to 30 are raised by the prior art discussed herein.

With respect to claims 31 and 32, the applicant in the original prosecution emphasized that the prior art failed to teach a vehicle proximity alarm that is activated based upon three parameters: (1) road speed, as determined by a road speed sensor; (2) separation, as determined by a radar detector; and (3) a vehicle speed/stopping distance table stored in a memory subsystem. Because the prosecution history focused on a vehicle proximity alarm that is activated based on these three parameters, and because the prior art disclosed herein discloses a vehicle proximity alarm activated based on these three parameters, substantial new questions of patentability affecting claims 31 and 32 are raised by the prior art discussed herein.

**1. Claim 1 is Obvious Under 35 U.S.C. § 103(a) in View of the Combination of Jurgen and Saturn '452**

Claim 1 is obvious under 35 U.S.C. § 103(a) in view of the combination of Jurgen and Saturn '452. Neither Jurgen nor Saturn '452 was cited by the Examiner or the applicants during prosecution of the '781 patent. Therefore, the question of whether claim 1 is obvious in view of the combination of Jurgen and Saturn '452 was not previously considered. The combination of Jurgen and Saturn '452 is closer to the subject matter of claim 1 of the '781

patent than any prior art that was relied upon during prosecution of the '781 patent. The combination of Jurgen and Saturn '452 provides new, non-cumulative technical teachings that were not otherwise provided in any prior art that was relied upon during prosecution of the '781 patent.

As more fully explained above, the Examiner concluded that claim 1 was allowable over the prior art cited during prosecution on the basis that the prior art does not teach an upshift notification circuit, wherein the processor determines, based upon data received from sensors, when to activate said upshift notification circuit.

Jurgen discloses an electronic engine control system that receives sensor inputs, evaluates them, and determines the necessary outputs to provide for optimal driveability. (Jurgen, page 12.1). Jurgen also discloses that these sensors monitor engine speed (page 7.6), road speed (pages 7.8, 14.3), manifold pressure (pages 2.5, 2.7), and throttle position (page 12.21). Jurgen also teaches that the use of processor subsystems to receive inputs from these sensors was known. (Pages 12.1, 13.6, 22.6). “During the entire operating time of the vehicle, the ECUs are constantly supervising the sensors they are connected to.” (Page 22.6). Indeed, Jurgen illustrates these hardware parts:

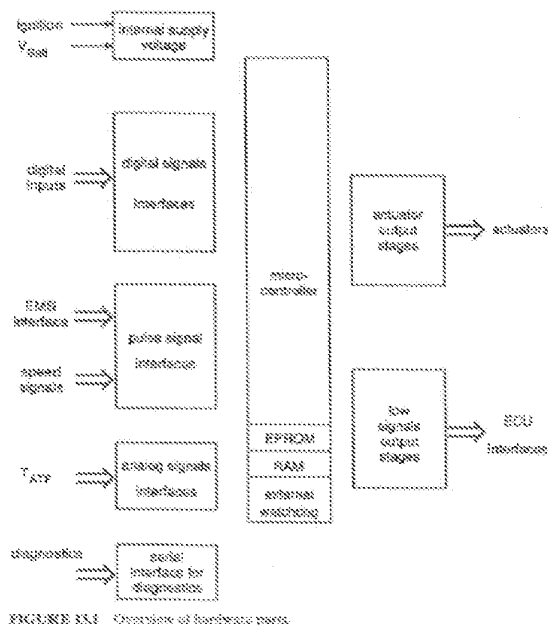

Jurgen, therefore, teaches “a plurality of sensors coupled to a vehicle having an engine, said plurality of sensors, which collectively monitor operation of said vehicle, including a road speed sensor, an engine speed sensor, a manifold pressure sensor and a



throttle position sensor” and “a processor subsystem, coupled to each one of said plurality of sensors, to receive data therefrom.”

Jurgen also discloses that a memory subsystem can be used in connection with the processor subsystem in order to store programs and data. (Page 13.5). It is disclosed that the memory can store data tables including a manifold pressure set point and an RPM set point for use by the system. (Pages 13.5 (“The memory devices for program and data are usually EPROMs”), 12.9 (“The engine load information is provided by the manifold pressure sensor . . . . The engine control unit contains data tables for combinations of load and RPM”)). Additionally, present and prior levels of each sensor are stored in the memory for diagnostic use, which preserves sensor outputs for later use. (Pages 14.2, 22.2 to 22.3). Jurgen, therefore, teaches “a memory subsystem, coupled to said processor subsystem, said memory subsystem storing therein a manifold pressure set point, an RPM set point, and present and prior levels for each one of said plurality of sensors.”

Jurgen teaches a fuel overinjection notification circuit, which issues a notification that excessive fuel is being supplied to the engine of the vehicle. For example, the ECU taught by Jurgen can shut off fuel in certain situations by evaluating the throttle position, engine RPM, and vehicle speed. (Page 12.4). Additionally, the ECU can shut off fuel injectors when a maximum speed is achieved (page 12.14). The ECU provides the fuel overinjection notification to the fuel injectors when a fuel cutoff state is reached. Jurgen, therefore, teaches “a fuel overinjection notification circuit coupled to said processor subsystem, said fuel overinjection notification circuit issuing a notification that excessive fuel is being supplied to said engine of said vehicle.”

Jurgen also teaches that the transmission can be controlled by calculating the necessary shift points based upon throttle position, the accelerator pedal position (e.g., throttle position), and the vehicle speed. (Page 13.9). “The shift point limitations are made, on the one hand, by the highest admissible engine speed for each application.” *Id.* The TCU (transmission control unit) stores shift maps that provide notifications to the transmission regarding whether and when to shift. (Page 13.14). Jurgen, therefore, teaches “an upshift notification circuit coupled to said processor subsystem, said upshift notification circuit issuing a notification that said engine of said vehicle is being operated at an excessive speed.”

Jurgen teaches “said processor subsystem determining, based upon data received from said plurality of sensors, when to activate said fuel overinjection circuit and when to activate said upshift/downshift notification circuit.” For example, the combination of the ECU, which monitors all of the vehicle’s sensors (see above) and the TCU, which stores the shift maps,

can send notification circuits to the fuel injectors and/or the transmission in order to alleviate a fuel overinjection condition or shift the engine.

Saturn '452 teaches a "means for indicating to the operator a point in operation for upshifting to the next higher gear." Abstract. The processor subsystem taught by Saturn '452 receives sensor inputs that sense manifold pressure, engine speed, and throttle position. Col. 2, lines 42 to 44; col. 7, lines 13 to 21. Therefore, Saturn '452 teaches "a plurality of sensors coupled to a vehicle having an engine, said plurality of sensors, which collectively monitor operation of said vehicle, including a road speed sensor, an engine speed sensor, a manifold pressure sensor and a throttle position sensor," except for the claimed road speed sensor, which is taught by Jurgen.

Figure 1 of Saturn '452 is illustrative:

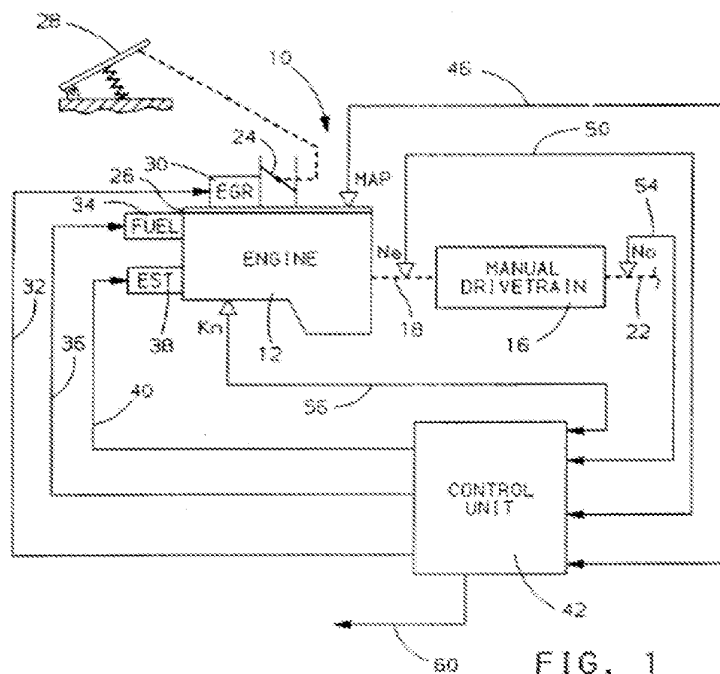

Figure 1 of Saturn '452 illustrates that the control unit 42 is connected to the sensor inputs, and outputs a signal on line 60 that may drive a lamp "for indicating the state of the upshift indicator light." Col. 2, lines 42 to 55; col. 3, lines 60 to 65. Additionally, Saturn '452 teaches that the control unit includes a memory (col. 2, lines 52 to 55), and that a "predetermined maximum allowable engine speed threshold K1" is used by the system. Col. 6, lines 55 to 60. Therefore, Saturn '452 discloses "a memory subsystem, coupled to said processor subsystem, said memory subsystem storing therein a manifold pressure set point,

an RPM set point, and present and prior levels for each one of said plurality of sensors,” except for the claimed manifold pressure set point and present and prior levels for each one of the sensors, which are taught by Jorgen (*see* Jorgen at 12.9, 13.5).

Saturn '452 teaches an upshift notification circuit connected to the control unit, which indicates “via line 60 the state of an upshift indicator light or equivalent visual display.” Col. 2, lines 42 to 55. Therefore, Saturn '452 teaches “an upshift notification circuit coupled to said processor subsystem, said upshift notification circuit issuing a notification that said engine of said vehicle is being operated at an excessive speed” and “said processor subsystem determining, based upon data received from said plurality of sensors, . . . when to activate said upshift notification circuit.”

A person of ordinary skill in the art, at the time the alleged invention of claim 1 of the '781 patent was made, would have found it obvious to combine the teachings of Jorgen and Saturn '452, and, in addition, would have been motivated to do so. Indeed, Jorgen, for example, expressly describes one such motivation: “The motive for using an electronic engine control system is to provide the needed accuracy and adaptability in order to minimize exhaust emissions and fuel consumption, provide optimal driveability for all operating conditions, minimize evaporative emissions, and provide system diagnosis when malfunctions occur.” (Jorgen, Page 12.1). A person of ordinary skill in the art, at the time the alleged invention of claim 1 of the '781 patent was made would have been further motivated to combine the teachings of Jorgen and Saturn '452 to “provide[] the fuel metering and ignition timing precision to minimize fuel consumption (Jorgen, Page 12.4), to provide a “means for indicating to the operator a point in operation for upshifting to the next higher gear” (Saturn '452, Abstract), and to provide “an improved method of determining shift points and indicating the same to a vehicle operator in order to maximize real driving fuel economy” (Saturn '452, col. 1, lines 44 to 47). The '781 patent states that its object is to “provide a system which integrates the ability to issue audible warnings which advise the driver to correct operation of the vehicle in a manner which will *enhance the efficient operation* thereof with the ability to automatically take corrective action if the vehicle is being operated unsafely.” Col. 1, line 66 to col. 2, line 5. Thus, like the '781 patent, Jorgen and Saturn '452 are concerned with, for example, improving fuel efficiency.

Furthermore, as additional evidence that a person of ordinary skill in the art would be motivated to combine the teachings of Jorgen and the teachings of Saturn '452, Jorgen describes at page xviii:

Automotive electronics as we know it today encompasses a wide variety of devices and systems. Key to

them all, and those yet to come, is the ability to sense and measure accurately automotive parameters. Equally important at the output is the ability to initiate control actions accurately in response to commands. In other words, sensors and actuators are the heart of any automotive electronics application. . . .

The importance of sensors and actuators cannot be overemphasized. The future growth of automotive electronics is arguably more dependent on sufficiently accurate and low-cost sensors and actuators than on computers, controls, displays, and other technologies.

Moreover, the combination of these teachings is merely (a) the combination of prior art elements according to known methods to yield predictable results; (b) the simple substitution of known elements for one another to obtain predictable results; (c) the use of known techniques to improve similar devices in the same way; (d) the application of known techniques to known devices ready for improvement to yield predictable results; (e) obvious to try; and (f) known to work in one field of endeavor prompting variations for use in either the same field or a different one based on design incentives or other market forces since the variations are predictable to one of ordinary skill in the art.

Thus, the combination of Jurgen and Saturn '452 teaches the limitations that the Examiner concluded were absent from the prior art cited during prosecution of the '781 patent, *i.e.*, an upshift notification circuit activated by a processor in response to sensor inputs. Accordingly, a substantial new question of patentability affecting claim 1 is raised by the combination of Jurgen and Saturn '452.

As set forth in the appended charts, the combination of Jurgen and Saturn '452 teaches all of the limitations of claim 1 of the '781 patent and therefore renders obvious claim 1 of the '781 patent. Therefore, VWGoA proposes a ground of rejection of claim 1 of the '781 patent under 35 U.S.C. § 103(a) as obvious in view of the combination of Jurgen and Saturn '452.

## **2. Claims 1, 7, and 13 are Obvious Under 35 U.S.C. § 103(a) in View of the Combination of Jurgen and Toyota '599**

Claims 1, 7, and 13 are obvious under 35 U.S.C. § 103(a) in view of the combination of Jurgen and Toyota '599. Neither Jurgen nor Toyota '599 was cited by the Examiner or the applicants during prosecution. Therefore, the question of whether claims 1, 7, and 13 are obvious in view of the combination of Jurgen and Toyota '599 was not previously considered. The combination of Jurgen and Toyota '599 is closer to the subject matter of

claims 1, 7, and 13 of the '781 patent than any prior art that was relied upon during prosecution of the '781 patent. The combination of Jurgen and Toyota '599 provides new, non-cumulative technical teachings that were not otherwise provided in any prior art that was relied upon during prosecution of the '781 patent.

As more fully explained above, the Examiner concluded that claims 1, 7, and 13 were allowable over the prior art cited during prosecution on the basis that the prior art does not teach upshift and/or downshift notification circuits, wherein the processor determines, based upon data received from sensors, when to activate said upshift and/or downshift notification circuits.

Jurgen discloses an electronic engine control system that receives sensor inputs, evaluates them, and determines the necessary outputs to provide for optimal driveability. (Jurgen, page 12.1). Jurgen also discloses that these sensors monitor engine speed (page 7.6), road speed (pages 7.8, 14.3), manifold pressure (pages 2.5, 2.7), and throttle position (page 12.21). Jurgen also teaches that the use of processor subsystems to receive inputs from these sensors was known. (Pages 12.1, 13.6, 22.6). “During the entire operating time of the vehicle, the ECUs are constantly supervising the sensors they are connected to.” (Page 22.6). Indeed, Jurgen illustrated a diagram of these hardware parts:

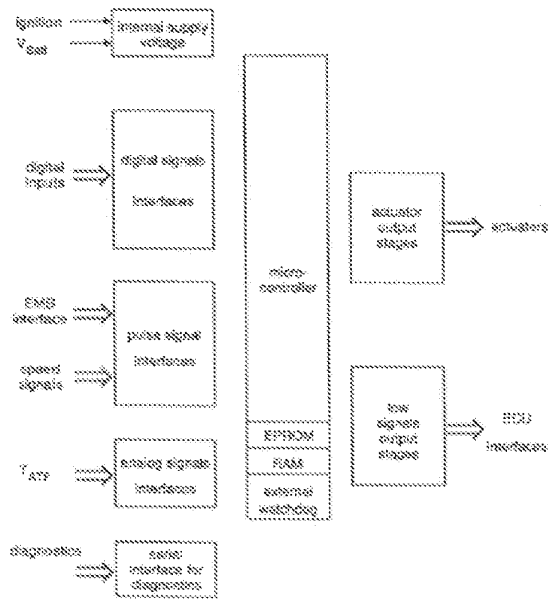

FIGURE 13.1 Overview of hardware parts.

Jurgen, therefore, teaches “a plurality of sensors coupled to a vehicle having an engine, said plurality of sensors, which collectively monitor operation of said vehicle, including a road speed sensor, an engine speed sensor, a manifold pressure sensor and a

throttle position sensor” and “a processor subsystem, coupled to each one of said plurality of sensors, to receive data therefrom.”

Jurgen also discloses that a memory subsystem can be used in connection with the processor subsystem in order to store programs and data. (Page 13.5). It is disclosed that the memory can store data tables including a manifold pressure set point and an RPM set point for use by the system. (Pages 13.5 (“The memory devices for program and data are usually EPROMs”), 12.9 (“The engine load information is provided by the manifold pressure sensor . . . . The engine control unit contains data tables for combinations of load and RPM”). Additionally, present and prior levels of each sensor are stored in the memory for diagnostic use, which preserves sensor outputs for later use. (Pages 14.2, 22.2 to 22.3). Jurgen, therefore, teaches “a memory subsystem, coupled to said processor subsystem, said memory subsystem storing therein a manifold pressure set point, an RPM set point, and present and prior levels for each one of said plurality of sensors.”

Jurgen teaches a fuel overinjection notification circuit, which issues a notification that excessive fuel is being supplied to the engine of the vehicle. For example, the ECU taught by Jurgen can shut off fuel in certain situations by evaluating the throttle position, engine RPM, and vehicle speed. (Page 12.4). Additionally, the ECU can shut off fuel injectors when a maximum speed is achieved (page 12.14). The ECU provides the fuel overinjection notification to the fuel injectors when a fuel cutoff state is reached. Jurgen, therefore, teaches “a fuel overinjection notification circuit coupled to said processor subsystem, said fuel overinjection notification circuit issuing a notification that excessive fuel is being supplied to said engine of said vehicle.”

Jurgen also teaches that the transmission can be controlled by calculating the necessary shift points based upon throttle position, the accelerator pedal position (e.g., throttle position), and the vehicle speed. (Page 13.9). “The shift point limitations are made, on the one hand, by the highest admissible engine speed for each application.” *Id.* The TCU (transmission control unit) stores shift maps that provide notifications to the transmission regarding whether and when to shift. (Page 13.14). Jurgen, therefore, teaches “an upshift[/downshift] notification circuit coupled to said processor subsystem, said upshift[/downshift] notification circuit issuing a notification that said engine of said vehicle is being operated at an excessive[/insufficient] speed.”

Jurgen teaches “said processor subsystem determining, based upon data received from said plurality of sensors, when to activate said fuel overinjection circuit and when to activate said upshift/downshift notification circuit.” For example, the combination of the ECU, which

monitors all of the vehicle's sensors (see above) and the TCU, which stores the shift maps, can send notification circuits to the fuel injectors and/or the transmission in order to alleviate a fuel overinjection condition or shift the engine.

Toyota '599 discloses a "shift indication apparatus" coupled to a plurality of sensors. An overview of this system is illustrated in Figure 1:

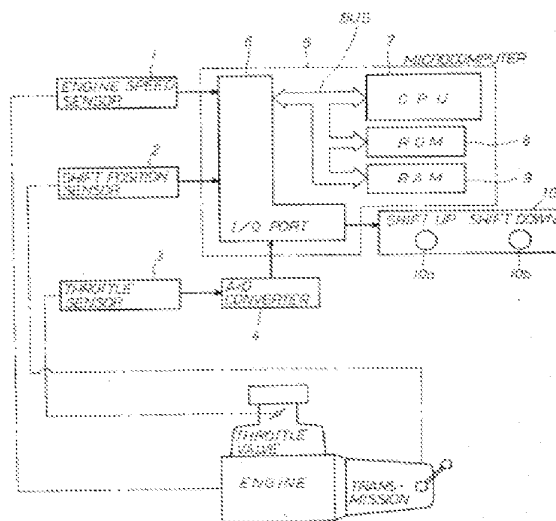

The sensor inputs to the microcomputer include an engine speed sensor 1 and a throttle sensor 3, which are both "connected to the input of the I/O port 6 so as to transmit the output pulses to the microcomputer 5." Col. 2, lines 43 to 48; col. 2, lines 52 to 59. Therefore, Toyota '599 teaches "a plurality of sensors coupled to a vehicle having an engine, said plurality of sensors, which collectively monitor operation of said vehicle, including a road speed sensor, an engine speed sensor, a manifold pressure sensor and a throttle position sensor," except for the claimed manifold pressure sensor and road speed sensor, which is taught by Jurgen. *See, e.g.*, Jurgen, pages 2.5, 2.7, and 7.6. Toyota '599 also teaches "a processor subsystem, coupled to each one of said plurality of sensors, to receive data therefrom."

Additionally, Toyota '599 teaches that a memory can be used to store a torque data map and an RPM set point. Col. 3, lines 7 to 20 and lines 44 to 61. For example, the engine speed "is read from the RAM 9 and it is compared with a predetermined number N (=1000 rpm) to determine whether or not the  $N_e$  exceeds the value 1000 at the step 21." Col. 3, lines 44 to 61. The actual RPM exceeding this RPM set point is necessary to begin the main routine. Therefore, Toyota '599 teaches "a memory subsystem, coupled to said processor subsystem" and that said memory subsystem stores an "RPM set point."

Toyota '599 teaches that indicator lamps that tell the driver to shift up or shift down are lit by the microcomputer in order to tell the driver when to shift to improve fuel economy. "Namely, in this step, the speed change operation indicating signal is applied to the indicator or display 10 from the microcomputer 5 through the I/O port 6. As a result, a particular lamp in this case, a shift up indicating lamp in the indicator 10, is illuminated, thus indicating to the drive that the speed change from current shift position to the one step shifting up position  $SP_{+1}$  is preferable." Col. 5, line 63 to col. 6, line 2. "However, only when either one of the assumed fuel consumption rates above is better than the current fuel consumption rate  $B_e$ , the corresponding shift-up lamp or shift-down lamp in the indicator 10 is illuminated, thus indicating the necessity of the speed change operation." E.g. col. 7, lines 29 to 38. Therefore, Toyota '599 teaches "an upshift[/downshift] notification circuit coupled to said processor subsystem, said upshift[/downshift] notification circuit issuing a notification that said engine of said vehicle is being operated at an excessive[/insufficient] speed" and "said processor subsystem determining, based upon data received from said plurality of sensors, . . . when to activate said upshift[/downshift] notification circuit."

A person of ordinary skill in the art, at the time the alleged inventions of claims 1, 7, and 13 of the '781 patent were made, would have found it obvious to combine the teachings of Jurgen and Toyota '599, and, in addition, would have been motivated to do so. Indeed, Jurgen, for example, expressly describes one such motivation: "The motive for using an electronic engine control system is to provide the needed accuracy and adaptability in order to minimize exhaust emissions and fuel consumption, provide optimal driveability for all operating conditions, minimize evaporative emissions, and provide system diagnosis when malfunctions occur." (Jurgen, Page 12.1). A person of ordinary skill in the art, at the time the alleged inventions of claims 1, 7, and 13 of the '781 patent were made would have been further motivated to combine the teachings of Jurgen and Toyota '599 to "provide optimal driveability for all operating conditions" (Jurgen, Page 12.1), to "provide[] the fuel metering and ignition timing precision to minimize fuel consumption (Jurgen, Page 12.4), and to "obtain preferable shift positions relating to optimum fuel consumption rate in accordance with . . . data detected" (Toyota '599, Abstract). The '781 patent states that its object is to "provide a system which integrates the ability to issue audible warnings which advise the driver to correct operation of the vehicle in a manner which will *enhance the efficient operation* thereof with the ability to automatically take corrective action if the vehicle is being operated unsafely." Col. 1, line 66 to col. 2, line 5. Thus, like the '781 patent, Jurgen and Toyota '599 are concerned with, for example, improving fuel efficiency.



Furthermore, as additional evidence that a person of ordinary skill in the art would be motivated to combine the teachings of Jurgen and the teachings of Toyota '599, Jurgen describes at page xvii:

Automotive electronics as we know it today encompasses a wide variety of devices and systems. Key to them all, and those yet to come, is the ability to sense and measure accurately automotive parameters. Equally important at the output is the ability to initiate control actions accurately in response to commands. In other words, sensors and actuators are the heart of any automotive electronics application. . . .

The importance of sensors and actuators cannot be overemphasized. The future growth of automotive electronics is arguably more dependent on sufficiently accurate and low-cost sensors and actuators than on computers, controls, displays, and other technologies.

Moreover, the combination of these teachings is merely (a) the combination of prior art elements according to known methods to yield predictable results; (b) the simple substitution of known elements for one another to obtain predictable results; (c) the use of known techniques to improve similar devices in the same way; (d) the application of known techniques to known devices ready for improvement to yield predictable results; (e) obvious to try; and (f) known to work in one field of endeavor prompting variations for use in either the same field or a different one based on design incentives or other market forces since the variations are predictable to one of ordinary skill in the art.

Thus, the combination of Jurgen and Toyota '599 teaches the limitations that the Examiner concluded were absent from the prior art cited during prosecution of the '781 patent, *i.e.*, upshift and downshift notification circuits activated by a processor in response to sensor inputs. Accordingly, a substantial new question of patentability affecting claims 1, 7, and 13 is raised by the combination of Jurgen and Toyota '599.

As set forth in the appended charts, the combination of Jurgen and Toyota '599 teaches all of the limitations of claims 1, 7, and 13 of the '781 patent and therefore renders obvious claims 1, 7, and 13 of the '781 patent. Therefore, VWGoA proposes a ground of rejection of claims 1, 7, and 13 of the '781 patent under 35 U.S.C. § 103(a) as obvious in view of the combination of Jurgen and Toyota '599.

**3. Claims 1, 7, and 13 are Obvious Under 35 U.S.C. § 103(a) in View of the Combination of Jurgen and Volkswagen '070**

Claims 1, 7, and 13 are obvious under 35 U.S.C. § 103(a) in view of the combination of Jurgen and Volkswagen '070. Neither Jurgen nor Volkswagen '070 was cited by the Examiner or the applicants during prosecution. Therefore, the question of whether claims 1, 7, and 13 are obvious in view of the combination of Jurgen and Volkswagen '070 was not previously considered. The combination of Jurgen and Volkswagen '070 is closer to the subject matter of claims 1, 7, and 13 of the '781 patent than any prior art that was relied upon during prosecution of the '781 patent. The combination of Jurgen and Volkswagen '070 provides new, non-cumulative technical teachings that were not otherwise provided in any prior art that was relied upon during prosecution of the '781 patent.

As more fully explained above, the Examiner concluded that claims 1, 7, and 13 were allowable over the prior art cited during prosecution on the basis that the prior art does not teach upshift and/or downshift notification circuits, wherein the processor determines, based upon data received from sensors, when to activate said upshift and/or downshift notification circuits.

Jurgen discloses an electronic engine control system that receives sensor inputs, evaluates them, and determines the necessary outputs to provide for optimal driveability. (Jurgen, page 12.1). Jurgen also discloses that these sensors monitor engine speed (page 7.6), road speed (pages 7.8, 14.3), manifold pressure (pages 2.5, 2.7), and throttle position (page 12.21). Jurgen also teaches that the use of processor subsystems to receive inputs from these sensors was known. (Pages 12.1, 13.6, 22.6). "During the entire operating time of the vehicle, the ECUs are constantly supervising the sensors they are connected to." (Page 22.6). Indeed, Jurgen illustrates a diagram of these hardware parts:

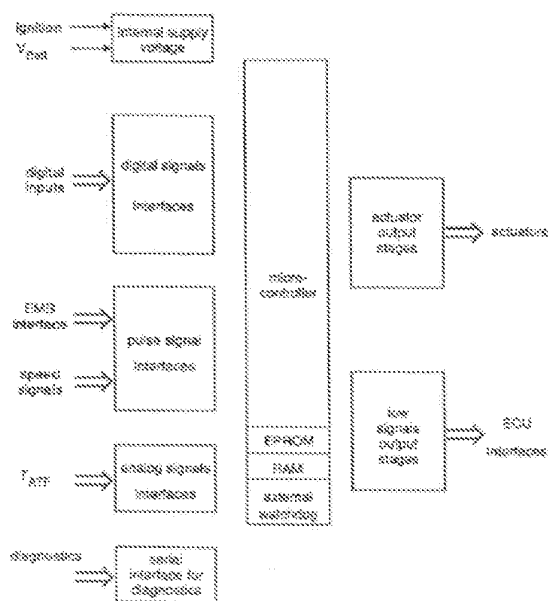

FIGURE 12.3 Overview of motor system parts.

Jurgen, therefore, teaches “a plurality of sensors coupled to a vehicle having an engine, said plurality of sensors, which collectively monitor operation of said vehicle, including a road speed sensor, an engine speed sensor, a manifold pressure sensor and a throttle position sensor” and “a processor subsystem, coupled to each one of said plurality of sensors, to receive data therefrom.”

Jurgen also discloses that a memory subsystem can be used in connection with the processor subsystem in order to store programs and data. (Page 13.5). It is disclosed that the memory can store data tables including a manifold pressure set point and an RPM set point for use by the system. (Pages 13.5 (“The memory devices for program and data are usually EPROMs”), 12.9 (“The engine load information is provided by the manifold pressure sensor . . . . The engine control unit contains data tables for combinations of load and RPM”). Additionally, present and prior levels of each sensor are stored in the memory for diagnostic use, which preserves sensor outputs for later use. (Pages 14.2, 22.2 to 22.3). Jurgen, therefore, teaches “a memory subsystem, coupled to said processor subsystem, said memory subsystem storing therein a manifold pressure set point, an RPM set point, and present and prior levels for each one of said plurality of sensors.”

Jurgen teaches a fuel overinjection notification circuit, which issues a notification that excessive fuel is being supplied to the engine of the vehicle. For example, the ECU taught by Jurgen can shut off fuel in certain situations by evaluating the throttle position, engine RPM, and vehicle speed. (Page 12.4). Additionally, the ECU can shut off fuel injectors when a

maximum speed is achieved (page 12.14). The ECU provides the fuel overinjection notification to the fuel injectors when a fuel cutoff state is reached. Jurgen, therefore, teaches “a fuel overinjection notification circuit coupled to said processor subsystem, said fuel overinjection notification circuit issuing a notification that excessive fuel is being supplied to said engine of said vehicle.”

Volkswagen '070 acknowledges that automobile instrument panels that display fuel economy are in the prior art. For example, Volkswagen '070 describes at page 9:

It is useful in addition to this device, a display of the route-specific fuel consumption is provided in a vehicle. Such display devices are known per se; they generally utilize the *induction manifold vacuum* as a measure of the fuel consumption. . . . In this case it is useful to integrate the signal transmitters denoted by 4 and 5 in Figure 2 into the instrument of the fuel consumption display, as sketched in Figure 3. During standard driving operation, pointer 30 of the fuel consumption display sweeps scale 31, while it is hidden behind cover 32 during an idling operation or at full-load accelerations. Incorporated in the scale is arrow 33, which constitutes part of a signal transmitter requesting upshifting, which therefore corresponds to signal transmitter 4 in Figure 2.

(emphasis added)

Thus, by describing a fuel consumption display that indicates full-load acceleration, Volkswagen '070 teaches “a fuel overinjection notification circuit coupled to said processor subsystem, said fuel overinjection notification circuit issuing a notification that excessive fuel is being supplied to said engine of said vehicle.”

Jurgen teaches that the transmission can be controlled by calculating the necessary shift points based upon throttle position, the accelerator pedal position (e.g., throttle position), and the vehicle speed. (Page 13.9). “The shift point limitations are made, on the one hand, by the highest admissible engine speed for each application.” *Id.* The TCU (transmission control unit) stores shift maps that provide notifications to the transmission regarding whether and when to shift. (Page 13.14). Jurgen, therefore, teaches “an upshift[/downshift] notification circuit coupled to said processor subsystem, said upshift[/downshift] notification circuit issuing a notification that said engine of said vehicle is being operated at an excessive[/insufficient] speed.”

Jurgen teaches “said processor subsystem determining, based upon data received from said plurality of sensors, when to activate said fuel overinjection circuit and when to activate said upshift/downshift notification circuit.” For example, the combination of the ECU, which monitors all of the vehicle’s sensors (see above) and the TCU, which stores the shift maps,

can send notification circuits to the fuel injectors and/or the transmission in order to alleviate a fuel overinjection condition or shift the engine.

Volkswagen '070 discloses a device “that assists the operator of [an] internal combustion engine equipped with a conventional transmission.” Page 5. The device receives an engine speed signal “with the aid of known sensor systems” and uses it to activate an “engine-speed dependent change-over switch 6.” Page 7. Volkswagen '070 describes two operating ranges, I and II, and the change-over switch 6 indicates that an upshift or downshift is necessary when the limits of those ranges (*e.g.*, the RPM set point) is reached. Pages 6–8. For example, Figure 2 of Volkswagen '070 illustrates the change-over switch, which receives the engine speed signal and determines when to activate the upshift and downshift notification lamps 4 and 5:

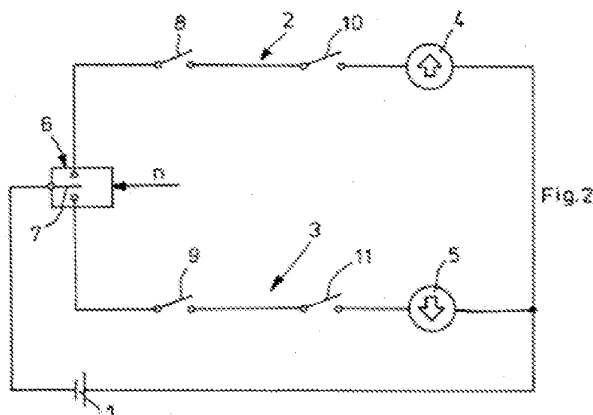

Volkswagen '070 also teaches that engine operating efficiency is based on throttle valve angle, induction manifold vacuum, and engine speed. For example, at page 6, Volkswagen '070 describes:

As can be seen when viewing Figure 1 to begin with, output  $N$  of the engine has been plotted across engine speed  $n$ .  $a$  is the curve of the output at full load,  $b$  is a line that represents a constant setting of the output control element, *i.e.*, a line that represents a constant **throttle valve angle** in a carburetor engine. As a measure thereof, in addition to the **throttle valve angle** itself, it is also possible to use the **induction manifold vacuum**. . . . The operating ranges I and II are further delimited by **engine speed values**  $n_1$  or  $n_2$ , the first of which usually lies between approximately 20 to 50% of the maximum engine speed, and the second usually lies between 40 to 70% of the maximum engine speed.

Volkswagen '070 also describes at page 8 that the “engine speed signal is obtained with the aid of known sensor systems.”

Therefore, Volkswagen '070 teaches “a plurality of sensors coupled to a vehicle having an engine, said plurality of sensors, which collectively monitor operation of said vehicle, including a road speed sensor, an engine speed sensor, a manifold pressure sensor and a throttle position sensor,” except for the claimed road speed sensor, which is taught by Jurgen. *See, e.g.*, Jurgen, pages 2.5, 2.7, 7.6, and 12.8. Volkswagen '070 also teaches “a processor subsystem, coupled to each one of said plurality of sensors, to receive data therefrom.”

Although Volkswagen '070 does not explicitly refer to the use of memory, it does disclose operating ranges I and II which are bounded by RPM set points, which trigger the shift notifications. For example, Figure 1 discloses these operating ranges, and includes limits N1 and N2 which are engine speeds at which the shifts are indicated (Pages 6–8):

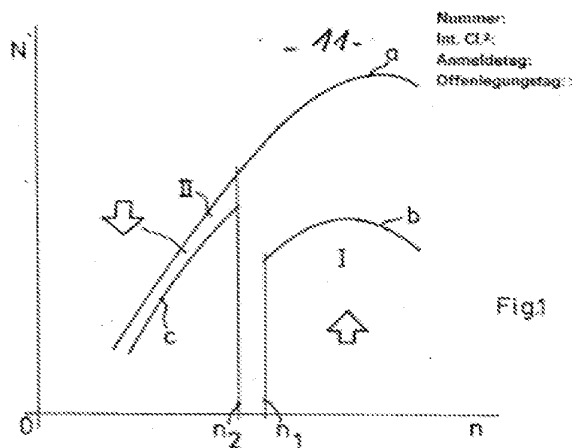

It would have been obvious to one having ordinary skill in the art to use a known memory device, such as the memory devices described by Jurgen at pages 11.24 to 11.31,<sup>5</sup> to store these set points. Therefore, the combination of Jurgen and Volkswagen '070 renders obvious an “RPM set point.”

<sup>5</sup> *See, e.g.*, pages 11.25 (“On-chip microcontroller memory consists of some mix of five basic types: random access memory (RAM), read-only memory (ROM), erasable ROM (EPROM), electrically erasable ROM (EEPROM), and flash memory. RAM is typically utilized for run-time variable storage and SFRs. The various types of ROM are generally used for code storage and fixed data tables.”) and 11.29 (“Off-chip memory offers the most flexibility to the system designer. . . . Off-chip memory is flexible because the user can implement various memory devices in the configuration of his choice. Most microcontrollers on the market today offer a wide variety of control pins and timing modes to allow the system designer flexibility when interfacing to a wide range of external memory systems.”).

Volkswagen '070 also teaches both upshift and downshift notification circuits, as upward and downward pointing arrows. When the engine is being operated at an excessive speed, an upshift notification circuit is activated. When the engine is being operated at an insufficient speed, the downshift notification circuit is activated. “Looking initially at operating range I remote from full load, *the desired output at a lower specific fuel consumption is able to be achieved after upshifting into the next higher gear*, at an operating point that lies to the left of operating range I in the diagram of Figure 1. *Accordingly, the device of the present invention generates a signal that asks the operator, i.e., normally the driver, to shift to a higher gear, which is indicated in Figure 1 by the upward pointing arrow within operating range I.*” Pages 6–7; “When the operating point lies in operating range II, *the device according to the present invention generates a signal that asks the driver to downshift, which is indicated by the downward pointing arrow at operating range II in Figure 1.*” Page 7. Volkswagen '070 also teaches that the change-over switch 6 pivots either upwardly or downwardly based upon the engine speed in order to drive the upshift or downshift indicator lights. Pages 7–8. Therefore, Volkswagen '070 teaches “an upshift[/downshift] notification circuit coupled to said processor subsystem, said upshift[/downshift] notification circuit issuing a notification that said engine of said vehicle is being operated at an excessive[/insufficient] speed” and “said processor subsystem determining, based upon data received from said plurality of sensors, . . . when to activate said upshift[/downshift] notification circuit.”

A person of ordinary skill in the art, at the time the alleged inventions of claims 1, 7, and 13 of the '781 patent were made, would have found it obvious to combine the teachings of Jurgen and Volkswagen '070, and, in addition, would have been motivated to do so. Indeed, Jurgen, for example, expressly describes one such motivation: “The motive for using an electronic engine control system is to provide the needed accuracy and adaptability in order to minimize exhaust emissions and fuel consumption, provide optimal driveability for all operating conditions, minimize evaporative emissions, and provide system diagnosis when malfunctions occur.” (Jurgen, Page 12.1). A person of ordinary skill in the art, at the time the alleged inventions of claims 1, 7, and 13 of the '781 patent were made would have been further motivated to combine the teachings of Jurgen and Volkswagen '070, to “provide optimal driveability for all operating conditions” (Jurgen, Page 12.1), to “provide[] the fuel metering and ignition timing precision to minimize fuel consumption (Jurgen, Page 12.4), and to “provid[e] a device that assists the operator of the internal combustion engine equipped with a conventional transmission . . . for example, in setting an operating point of

the engine that is advantageous in terms of fuel consumption” (Volkswagen ’070, Page 5). The ’781 patent states that its object is to “provide a system which integrates the ability to issue audible warnings which advise the driver to correct operation of the vehicle in a manner which will *enhance the efficient operation* thereof with the ability to automatically take corrective action if the vehicle is being operated unsafely.” Col. 1, line 66 to col. 2, line 5. Thus, like the ’781 patent, Jurgen and Volkswagen ’070 are concerned with, for example, improving fuel efficiency.

Furthermore, as additional evidence that a person of ordinary skill in the art would be motivated to combine the teachings of Jurgen and the teachings of Volkswagen ’070, Jurgen describes at page xvii:

Automotive electronics as we know it today encompasses a wide variety of devices and systems. Key to them all, and those yet to come, is the ability to sense and measure accurately automotive parameters. Equally important at the output is the ability to initiate control actions accurately in response to commands. In other words, sensors and actuators are the heart of any automotive electronics application. . . .

The importance of sensors and actuators cannot be overemphasized. The future growth of automotive electronics is arguably more dependent on sufficiently accurate and low-cost sensors and actuators than on computers, controls, displays, and other technologies.

Moreover, the combination of these teachings is merely (a) the combination of prior art elements according to known methods to yield predictable results; (b) the simple substitution of known elements for one another to obtain predictable results; (c) the use of known techniques to improve similar devices in the same way; (d) the application of known techniques to known devices ready for improvement to yield predictable results; (e) obvious to try; and (f) known to work in one field of endeavor prompting variations for use in either the same field or a different one based on design incentives or other market forces since the variations are predictable to one of ordinary skill in the art.

Thus, the combination of Jurgen and Volkswagen ’070 teaches the limitations that the Examiner concluded were absent from the prior art cited during prosecution of the ’781 patent, *i.e.*, upshift and downshift notification circuits activated by a processor in response to sensor inputs. Accordingly, a substantial new question of patentability affecting claims 1, 7, and 13 is raised by the combination of Jurgen and Volkswagen ’070.



As set forth in the appended charts, the combination of Jurgen and Volkswagen '070 teaches all of the limitations of claims 1, 7, and 13 of the '781 patent and therefore renders obvious claims 1, 7, and 13 of the '781 patent. Therefore, VWGoA proposes a ground of rejection of claims 1, 7, and 13 of the '781 patent under 35 U.S.C. § 103(a) as obvious in view of the combination of Jurgen and Volkswagen '070.

**4. Claims 17–23 and 26 are Obvious Under 35 U.S.C. § 103(a) in View of the Combination of Jurgen, Toyota '599, and Davidian**

Claims 17–23 and 26 are obvious under 35 U.S.C. § 103(a) in view of the combination of Jurgen, Toyota '599, and Davidian. Jurgen, Toyota '599, and Davidian were not cited by the Examiner or the applicants during prosecution. Therefore, the question of whether claims 17–23 and 26 are obvious in view of the combination of Jurgen, Toyota '599, and Davidian was not previously considered. The combination of Jurgen, Toyota '599, and Davidian is closer to the subject matter of claims 17–23 and 26 of the '781 patent than any prior art that was relied upon during prosecution of the '781 patent. The combination of Jurgen, Toyota '599, and Davidian provides new, non-cumulative technical teachings that were not otherwise provided in any prior art that was relied upon during prosecution of the '781 patent.

As more fully explained above, the Examiner determined that claims 17–23 and 26 were allowable over the prior art cited during prosecution on the basis that the prior art does not teach upshift and/or downshift notification circuits, wherein the processor determines, based upon data received from sensors, when to activate said upshift and/or downshift notification circuits.

Jurgen discloses an electronic engine control system that receives sensor inputs, evaluates them, and determines the necessary outputs to provide for optimal driveability. (Jurgen, page 12.1). Jurgen also discloses that these sensors monitor engine speed (page 7.6), road speed (pages 7.8, 14.3), manifold pressure (pages 2.5, 2.7), and throttle position (page 12.21). Jurgen also teaches that the use of processor subsystems to receive inputs from these sensors was known. (Pages 12.1, 13.6, 22.6). “During the entire operating time of the vehicle, the ECUs are constantly supervising the sensors they are connected to.” (Page 22.6). Indeed, Jurgen illustrates a diagram of these hardware parts:

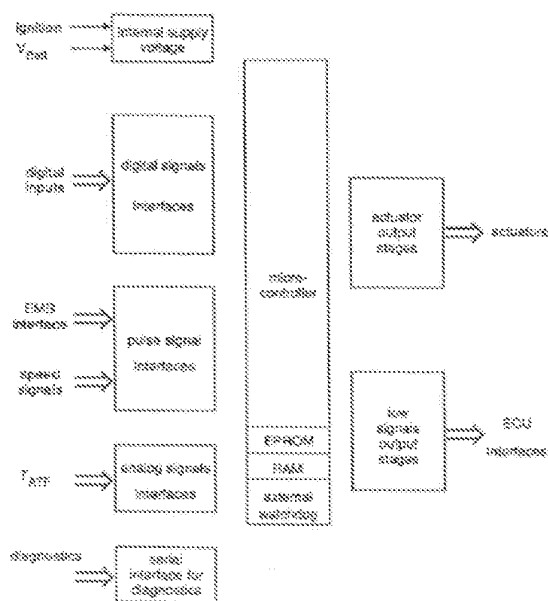

FIGURE 22.2 Overview of motor system parts.

Jurgen, therefore, teaches “a plurality of sensors coupled to a vehicle having an engine, said plurality of sensors, which collectively monitor operation of said vehicle, including a road speed sensor, an engine speed sensor, a manifold pressure sensor and a throttle position sensor” and “a processor subsystem, coupled to each one of said plurality of sensors, to receive data therefrom.”

Jurgen also discloses that a memory subsystem can be used in connection with the processor subsystem in order to store programs and data. (Page 13.5). It is disclosed that the memory can store data tables including a manifold pressure set point and an RPM set point for use by the system. (Pages 13.5 (“The memory devices for program and data are usually EPROMs”), 12.9 (“The engine load information is provided by the manifold pressure sensor . . . . The engine control unit contains data tables for combinations of load and RPM”). Additionally, present and prior levels of each sensor are stored in the memory for diagnostic use, which preserves sensor outputs for later use. (Pages 14.2, 22.2 to 22.3). Jurgen, therefore, teaches “a memory subsystem, coupled to said processor subsystem, said memory subsystem storing therein a manifold pressure set point, an RPM set point, and present and prior levels for each one of said plurality of sensors.”

Jurgen teaches a fuel overinjection notification circuit, which issues a notification that excessive fuel is being supplied to the engine of the vehicle. For example, the ECU taught by Jurgen can shut off fuel in certain situations by evaluating the throttle position, engine RPM, and vehicle speed. (Page 12.4). Additionally, the ECU can shut off fuel injectors when a

maximum speed is achieved (page 12.14). The ECU provides the fuel overinjection notification to the fuel injectors when a fuel cutoff state is reached. Jurgen, therefore, teaches “a fuel overinjection notification circuit coupled to said processor subsystem, said fuel overinjection notification circuit issuing a notification that excessive fuel is being supplied to said engine of said vehicle.”

Jurgen also teaches that the transmission can be controlled by calculating the necessary shift points based upon throttle position, the accelerator pedal position (e.g., throttle position), and the vehicle speed. (Page 13.9). “The shift point limitations are made, on the one hand, by the highest admissible engine speed for each application.” *Id.* The TCU (transmission control unit) stores shift maps that provide notifications to the transmission regarding whether and when to shift. (Page 13.14). Jurgen, therefore, teaches “an upshift[/downshift] notification circuit coupled to said processor subsystem, said upshift[/downshift] notification circuit issuing a notification that said engine of said vehicle is being operated at an excessive[/insufficient] speed.”

Jurgen teaches “said processor subsystem determining, based upon data received from said plurality of sensors, when to activate said fuel overinjection circuit and when to activate said upshift/downshift notification circuit.” For example, the combination of the ECU, which monitors all of the vehicle’s sensors (see above) and the TCU, which stores the shift maps, can send notification circuits to the fuel injectors and/or the transmission in order to alleviate a fuel overinjection condition or shift the engine.

Toyota ’599 discloses a “shift indication apparatus” coupled to a plurality of sensors. An overview of this system is illustrated in Figure 1:

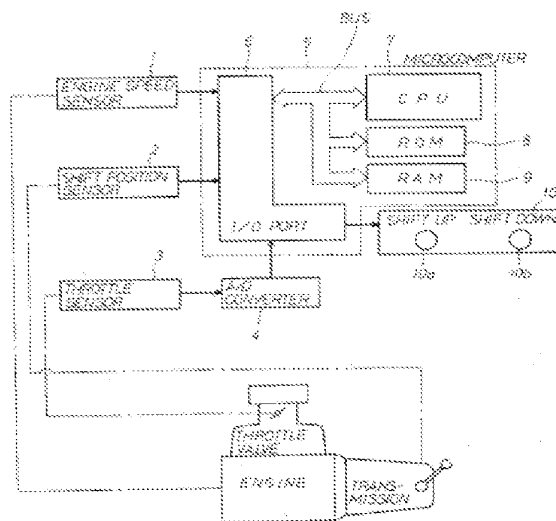

The sensor inputs to the microcomputer include an engine speed sensor 1 and a throttle sensor 3, which are both “connected to the input of the I/O port 6 so as to transmit the output pulses to the microcomputer 5.” Col. 2, lines 43 to 48; col. 2, lines 52 to 59. Therefore, Toyota ’599 discloses “a plurality of sensors coupled to a vehicle having an engine, said plurality of sensors, which collectively monitor operation of said vehicle, including a road speed sensor, an engine speed sensor, a manifold pressure sensor and a throttle position sensor,” except for the claimed manifold pressure sensor and road speed sensor, which is taught by Jurgen. *See, e.g.*, Jurgen, pages 2.5, 2.7, and 7.6. Toyota ’599 also teaches “a processor subsystem, coupled to each one of said plurality of sensors, to receive data therefrom.”

Additionally, Toyota ’599 teaches that a memory can be used to store a torque data map and an RPM set point. Col. 3, lines 7 to 20 and lines 44 to 61. For example, the engine speed “is read from the RAM 9 and it is compared with a predetermined number N (=1000 rpm) to determine whether or not the  $N_e$  exceeds the value 1000 at the step 21.” Col. 3, lines 44 to 61. The actual RPM exceeding this RPM set point is necessary to begin the main routine. Therefore, Toyota ’599 teaches “a memory subsystem, coupled to said processor subsystem” and that said memory subsystem stores an “RPM set point.”

Toyota ’599 teaches that indicator lamps that tell the driver to shift up or shift down are lit by the microcomputer in order to tell the driver when to shift to improve fuel economy. “Namely, in this step, the speed change operation indicating signal is applied to the indicator or display 10 from the microcomputer 5 through the I/O port 6. As a result, a particular lamp in this case, a shift up indicating lamp in the indicator 10, is illuminated, thus indicating to the driver that the speed change from current shift position to the one step shifting up position  $SP_{+1}$  is preferable.” Col. 5, line 63 to col. 6, line 2. “However, only when either one of the assumed fuel consumption rates above is better than the current fuel consumption rate  $B_e$ , the corresponding shift-up lamp or shift-down lamp in the indicator 10 is illuminated, thus indicating the necessity of the speed change operation.” E.g. col. 7, lines 29 to 38. Therefore, Toyota ’599 teaches “an upshift[/downshift] notification circuit coupled to said processor subsystem, said upshift[/downshift] notification circuit issuing a notification that said engine of said vehicle is being operated at an excessive[/insufficient] speed” and “said processor subsystem determining, based upon data received from said plurality of sensors, . . . when to activate said upshift[/downshift] notification circuit.”

Davidian discloses an anti-collision system that includes “a front space sensor 8 for sensing the space in front of the vehicle, such as the presence of another vehicle.” Col. 4,

lines 52 to 66. This front space sensor includes “a transmitter 106 and a receiver 108 for transmitting and receiving the pulses (e.g., RF, ultrasound, laser, IR, etc.) in the front space sensor 8 . . . for measuring the distance of the vehicle from objects in front of . . . the vehicle.” Col. 10, lines 17 to 26. The front space sensor in Davidian continuously transmits pulses (including, in one example, RF pulses) and measures “the round-trip time from the pulse transmission to the echo reception in order to determine the distance of the vehicle from the object.” Col. 10, lines 38 to 50. Therefore, Davidian teaches “a radar detector, said radar detector determining a distance separating a vehicle having an engine and an object in front of said vehicle.”

Davidian also teaches a processor subsystem, disclosed as microcomputer 4, which is illustrated in FIGS. 6a and 6b. It is coupled to the radar detector (front vehicle space sensor 8) and the vehicle speed sensor 12:

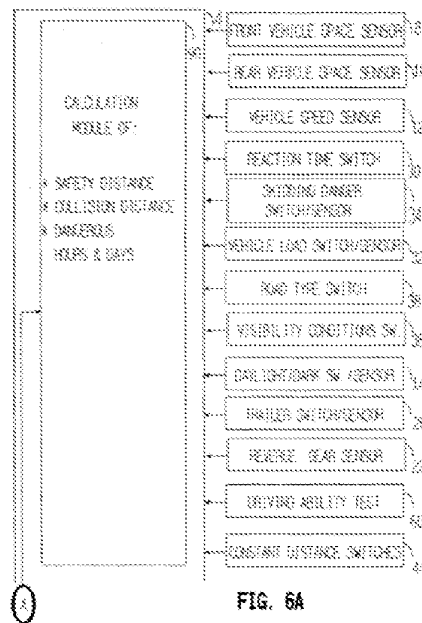

“The microcomputer 4 as illustrated in FIGS. 6a, 6b is divided into various functional modules, as follows: a calculation module 90, which receives data concerning the various parameters briefly described above.” Col. 8, lines 29 to 43. Therefore, Davidian teaches “a processor subsystem, coupled to said radar detector and said at least one sensor, to receive data therefrom.”

Davidian teaches a memory subsystem that stores a vehicle speed/stopping distance table. “*Computer module 90 also includes information about the vehicle braking distances as a function of speed. This is preferably in the form of a look-up table,* for example,

provided by the manufacturer for predetermined defined conditions concerning road type, skidding danger, vehicle load and tires pressure, and is *stored in a ROM (read-only memory) of the microcomputer so that it can be changed periodically if necessary.*” Col. 9, lines 20 to 27. This memory subsystem is a part of the microcomputer 4, as illustrated in FIG. 6A. Davidian also teaches the storing of present and prior levels of each sensor in memory. For example, Davidian’s “Black Box Module” 94 stores the “time, *speed*, and *relative distance* between the vehicle and object” each time a collision alarm is activated. Col. 15, lines 22 to 26. Therefore, Davidian teaches “a memory subsystem, coupled to said processor subsystem, said memory subsystem storing a first vehicle speed/stopping distance table” and the memory subsystem storing “a present level for each one of said at least one sensor and a prior level for each one of said at least one sensor.”

Davidian teaches a vehicle proximity alarm circuit, which activates a collision alarm when a calculated “Collision Distance” is close to a calculated “Stopping Distance.” “A determination is also made of the collision distance CD which is equal to the stopping distance SD divided by the collision safety factor CSF, e.g., 1.25 in the example illustrated above, such that should the distance between the vehicle and the object come within the collision distance CD, the collision alarm is then actuated.” Col. 12, line 59 to col. 13, line 11. The collision alarm, may be an audio alarm or a visual alarm. Col. 9, lines 52 to 56. The determination whether to activate the collision alarm is made by the calculation module 90, which is part of the microcomputer 4. *See* col. 12, line 27 (“Operation of the Calculation Module 90”). Therefore, Davidian teaches “a vehicle proximity alarm circuit coupled to said processor subsystem, said vehicle proximity alarm circuit issuing an alarm that said vehicle is too close to said object.”

Davidian also teaches that the processor subsystem determines when to activate the proximity alarm. The radar input, the vehicle speed input, and the vehicle speed/stopping distance tables are all located in the calculation module 90, which it uses to calculate stopping distance and collision distance. Col. 12, line 59 to col. 13, line 11. Therefore, Davidian teaches “said processor subsystem determining whether to activate said vehicle proximity alarm circuit based upon separation distance data received from said radar detector, vehicle speed data received from said road speed sensor and said first vehicle speed/stopping distance table stored in said memory subsystem.”

Davidian also teaches the use of a rain sensor connected to module 90 to detect the presence of rain. Claim 18 requires the use of a windshield wiper sensor in order to detect if rain is present. In rejecting claim 18, the Examiner stated that “Chasteen discloses a plurality

of sensors for controlling the operation of the fuel injection wherein it would have been obvious to use a windshield wiper sensor in order to provide a complete performance operation of the vehicle.” August 6, 1998 Office Action, at 5. This rejection was not challenged by the applicant, and the claim was allowed due to the addition of the upshift notification circuit to claim 17. The Examiner’s statement that a windshield wiper sensor would be an obvious modification to Chasteen carries equal weight in view of the rain sensor taught in Davidian.

Davidian also teaches that it would be beneficial in certain situations to take automatic control of the vehicle. Col. 2, lines 67 to col. 3, line 2. While Claim 19 requires a throttle controller that selectively reduces the throttle based upon inputs from various sensors, the disclosure in Davidian regarding the automatic application of the brakes achieves the same result — slowing the vehicle down.<sup>6</sup>

Jurgen teaches the use of a brake sensor as claimed in Claim 20. For example, Jurgen teaches that “[p]ressure sensors are used to monitor brake fluid pressure” and that “[b]rake pedal position and brake fluid pressure information are also required for control.” Jurgen, pages 7.21 to 22. Therefore, the combination of Jurgen, Toyota ’599, and Davidian teaches “at least one sensor further includes a brake sensor for indicating whether a brake system of said vehicle is activated.”

Davidian also teaches the use of a “black box” to record vehicle events. Claim 21 requires a “means for counting a total number of vehicle proximity alarms determined by said processor subsystem.” Davidian teaches the use of four different counters, which are stored in the black box each time a front or rear proximity alarm is activated. Col. 11, lines 60 to 68; col. 14, lines 8 to 12. Davidian does not teach “means for selectively reducing said throttle based upon said total number of vehicle proximity alarms.” However, Davidian does teach that automated activation of a brake system is used to slow the vehicle down. Indeed, the Examiner stated that “it has been discussed that Doi et al. disclose an alarm therefore it would have been obvious to one of ordinary skill in the art at the time of the invention to count a total number of alarms associated with the system.” August 6, 1998 Office Action, at 6. Davidian teaches counting the number of vehicle proximity alarms, and also teaches the automatic control of a vehicle. Therefore, Davidian renders obvious claim 21.

A person of ordinary skill in the art, at the time the alleged inventions of claims 17–23 and 26 of the ’781 patent were made, would have found it obvious to combine the teachings

---

<sup>6</sup> Additionally, Jurgen teaches that an electronic throttle controller was known in the art.

of Jurgen, Toyota '599, and Davidian, and, in addition, would have been motivated to do so. Indeed, Jurgen, for example, expressly describes one such motivation: “The motive for using an electronic engine control system is to provide the needed accuracy and adaptability in order to minimize exhaust emissions and fuel consumption, provide optimal driveability for all operating conditions, minimize evaporative emissions, and provide system diagnosis when malfunctions occur.” (Jurgen, Page 12.1). A person of ordinary skill in the art, at the time the alleged inventions of claims 17–23 and 26 of the '781 patent were made would have been further motivated to combine the teachings of Jurgen, Toyota '599, and Davidian, to “provide optimal driveability for all operating conditions” (Jurgen, Page 12.1), to “provide[] the fuel metering and ignition timing precision to minimize fuel consumption (Jurgen, Page 12.4), to “obtain preferable shift positions relating to optimum fuel consumption rate in accordance with . . . data detected” (Toyota '599, Abstract), and to provide an “anti-collision system for vehicles” that “computes[] the danger-of-collision distance to the object” (Davidian, Col. 1, line 7 and col. 2, lines 3 to 4). The '781 patent states that its object is to “provide a system which integrates the ability to issue audible warnings which advise the driver to correct operation of the vehicle in a manner which will *enhance the efficient operation* thereof with the ability to automatically take corrective action *if the vehicle is being operated unsafely.*” Col. 1, line 66 to col. 2, line 5. Thus, like the '781 patent, Jurgen, Toyota '599, and Davidian are concerned with, for example, improving fuel efficiency and safety.

Furthermore, as additional evidence that a person of ordinary skill in the art would be motivated to combine the teachings of Jurgen, Toyota '599, and Davidian, Jurgen describes at page xvii:

Automotive electronics as we know it today encompasses a wide variety of devices and systems. Key to them all, and those yet to come, is the ability to sense and measure accurately automotive parameters. Equally important at the output is the ability to initiate control actions accurately in response to commands. In other words, sensors and actuators are the heart of any automotive electronics application. . . .

The importance of sensors and actuators cannot be overemphasized. The future growth of automotive electronics is arguably more dependent on sufficiently accurate and low-cost sensors and actuators than on computers, controls, displays, and other technologies.

Moreover, the combination of these teachings is merely (a) the combination of prior art elements according to known methods to yield predictable results; (b) the simple



substitution of known elements for one another to obtain predictable results; (c) the use of known techniques to improve similar devices in the same way; (d) the application of known techniques to known devices ready for improvement to yield predictable results; (e) obvious to try; and (f) known to work in one field of endeavor prompting variations for use in either the same field or a different one based on design incentives or other market forces since the variations are predictable to one of ordinary skill in the art.

Thus, the combination of Jurgén, Toyota '599, and Davidian teaches the limitations that the Examiner concluded were absent from the prior art cited during prosecution of the '781 patent, *i.e.*, upshift and downshift notification circuits activated by a processor in response to sensor inputs. Accordingly, a substantial new question of patentability affecting claims 17–23 and 26 is raised by the combination of Jurgén, Toyota '599, and Davidian.

As set forth in the appended charts, the combination of Jurgén, Toyota '599, and Davidian teaches all of the limitations of claims 17–23 and 26 of the '781 patent and therefore renders obvious claims 17–23 and 26 of the '781 patent. Therefore, VWGoA proposes a ground of rejection of claims 17–23 and 26 of the '781 patent under 35 U.S.C. § 103(a) as obvious in view of the combination of Jurgén, Toyota '599, and Davidian.

#### **5. Claims 17–23 and 26 are Obvious Under 35 U.S.C. § 103(a) in View of the Combination of Jurgén, Volkswagen '070, and Davidian**

Claims 17–23 and 26 are obvious under 35 U.S.C. § 103(a) in view of the combination of Jurgén, Volkswagen '070, and Davidian. Jurgén, Volkswagen '070, and Davidian were not cited by the Examiner or the applicants during prosecution of the '781 patent. Therefore, the question of whether claims 17–23 and 26 are obvious in view of the combination of Jurgén, Volkswagen '070, and Davidian was not previously considered. The combination of Jurgén, Volkswagen '070, and Davidian is closer to the subject matter of claims 17–23 and 26 of the '781 patent than any prior art that was relied upon during prosecution of the '781 patent, and the combination of Jurgén, Volkswagen '070, and Davidian provides new, non-cumulative technical teachings that were not otherwise provided in any prior art that was relied upon during prosecution of the '781 patent.

As more fully explained above, the Examiner concluded that claims 17–23 and 26 were allowable over the prior art cited during prosecution on the basis that the prior art does not teach upshift and/or downshift notification circuits, wherein the processor determines, based upon data received from sensors, when to activate said upshift and/or downshift notification circuits.

Jurgen discloses an electronic engine control system that receives sensor inputs, evaluates them, and determines the necessary outputs to provide for optimal driveability. (Jurgen, page 12.1). Jurgen also discloses that these sensors monitor engine speed (page 7.6), road speed (pages 7.8, 14.3), manifold pressure (pages 2.5, 2.7), and throttle position (page 12.21). Jurgen also teaches that the use of processor subsystems to receive inputs from these sensors was known. (Pages 12.1, 13.6, 22.6). “During the entire operating time of the vehicle, the ECUs are constantly supervising the sensors they are connected to.” (Page 22.6). Indeed, Jurgen illustrates a diagram of these hardware parts:

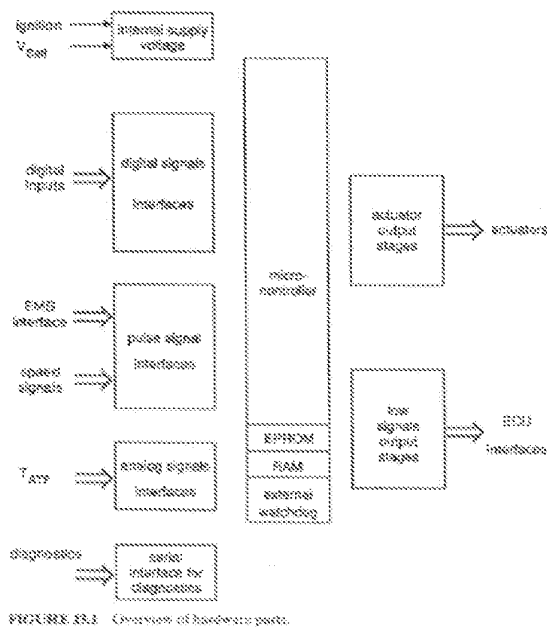

Jurgen, therefore, teaches “a plurality of sensors coupled to a vehicle having an engine, said plurality of sensors, which collectively monitor operation of said vehicle, including a road speed sensor, an engine speed sensor, a manifold pressure sensor and a throttle position sensor” and “a processor subsystem, coupled to each one of said plurality of sensors, to receive data therefrom.”

Jurgen also discloses that a memory subsystem can be used in connection with the processor subsystem in order to store programs and data. (Page 13.5). It is disclosed that the memory can store data tables including a manifold pressure set point and an RPM set point for use by the system. (Pages 13.5 (“The memory devices for program and data are usually EPROMs”), 12.9 (“The engine load information is provided by the manifold pressure sensor . . . . The engine control unit contains data tables for combinations of load and RPM”). Additionally, present and prior levels of each sensor are stored in the memory for diagnostic

use, which preserves sensor outputs for later use. (Pages 14.2, 22.2 to 22.3). Jurgen, therefore, teaches “a memory subsystem, coupled to said processor subsystem, said memory subsystem storing therein a manifold pressure set point, an RPM set point, and present and prior levels for each one of said plurality of sensors.”

Jurgen teaches a fuel overinjection notification circuit, which issues a notification that excessive fuel is being supplied to the engine of the vehicle. For example, the ECU taught by Jurgen can shut off fuel in certain situations by evaluating the throttle position, engine RPM, and vehicle speed. (Page 12.4). Additionally, the ECU can shut off fuel injectors when a maximum speed is achieved (page 12.14). The ECU provides the fuel overinjection notification to the fuel injectors when a fuel cutoff state is reached. Jurgen, therefore, teaches “a fuel overinjection notification circuit coupled to said processor subsystem, said fuel overinjection notification circuit issuing a notification that excessive fuel is being supplied to said engine of said vehicle.”

Jurgen also teaches that the transmission can be controlled by calculating the necessary shift points based upon throttle position, the accelerator pedal position (e.g., throttle position), and the vehicle speed. (Page 13.9). “The shift point limitations are made, on the one hand, by the highest admissible engine speed for each application.” *Id.* The TCU (transmission control unit) stores shift maps that provide notifications to the transmission regarding whether and when to shift. (Page 13.14). Jurgen, therefore, teaches “an upshift[/downshift] notification circuit coupled to said processor subsystem, said upshift[/downshift] notification circuit issuing a notification that said engine of said vehicle is being operated at an excessive[/insufficient] speed.”

Jurgen teaches “said processor subsystem determining, based upon data received from said plurality of sensors, when to activate said fuel overinjection circuit and when to activate said upshift/downshift notification circuit.” For example, the combination of the ECU, which monitors all of the vehicle’s sensors (see above) and the TCU, which stores the shift maps, can send notification circuits to the fuel injectors and/or the transmission in order to alleviate a fuel overinjection condition or shift the engine.

Volkswagen ’070 discloses a device “that assists the operator of [an] internal combustion engine equipped with a conventional transmission.” Page 5. The device receives an engine speed signal “with the aid of known sensor systems” and uses it to activate an “engine-speed dependent change-over switch 6.” Page 7. Volkswagen ’070 describes two operating ranges, I and II, and the change-over switch 6 indicates that an upshift or downshift is necessary when the limits of those ranges (e.g., the RPM set point) is reached. Pages 6–8.

For example, Figure 2 of Volkswagen '070 illustrates the change-over switch, which receives the engine speed signal and determines when to activate the upshift and downshift notification lamps 4 and 6:

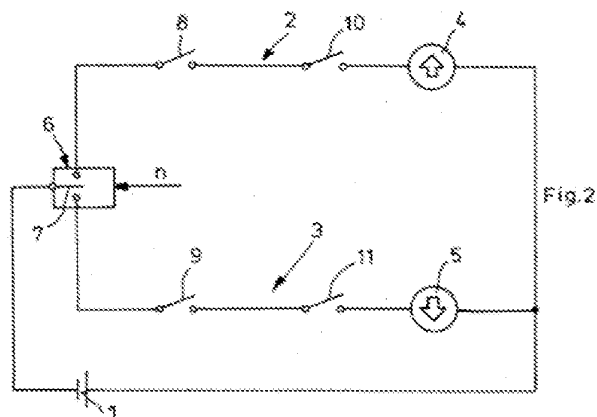

Volkswagen '070 also teaches that engine operating efficiency is based on throttle valve angle, induction manifold vacuum, and engine speed. For example, at page 6, Volkswagen '070 describes:

As can be seen when viewing Figure 1 to begin with, output  $N$  of the engine has been plotted across engine speed  $n$ .  $a$  is the curve of the output at full load,  $b$  is a line that represents a constant setting of the output control element, i.e., a line that represents a constant *throttle valve angle* in a carburetor engine. As a measure thereof, in addition to the *throttle valve angle* itself, it is also possible to use the *induction manifold vacuum*. . . . The operating ranges I and II are further delimited by *engine speed values*  $n_1$  or  $n_2$ , the first of which usually lies between approximately 20 to 50% of the maximum engine speed, and the second usually lies between 40 to 70% of the maximum engine speed.

Volkswagen '070 also describes at page 8 that the “engine speed signal is obtained with the aid of known sensor systems.”

Therefore, Volkswagen '070 teaches “a plurality of sensors coupled to a vehicle having an engine, said plurality of sensors, which collectively monitor operation of said vehicle, including a road speed sensor, an engine speed sensor, a manifold pressure sensor and a throttle position sensor,” except for the claimed road speed sensor, which is taught by Jurgen. See, e.g., Jurgen, pages 2.5, 2.7, 7.6, and 12.8. Volkswagen '070 also teaches “a processor subsystem, coupled to each one of said plurality of sensors, to receive data therefrom.”

Although Volkswagen '070 does not explicitly refer the use of memory, it does disclose operating ranges I and II which are bounded by RPM set points, which trigger the shift notifications. For example, Figure 1 illustrates these operating ranges, and includes limits N1 and N2 which are engine speeds at which the shifts are indicated (Pages 6–8):

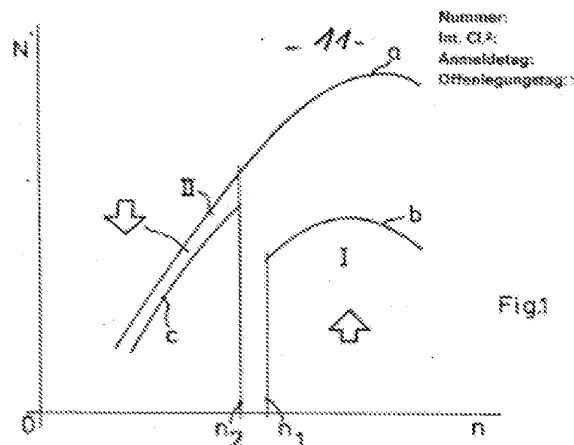

It would have been obvious to one having ordinary skill in the art to use a known memory device, such as the memory devices described by Jurgen at pages 11.24 to 11.31,<sup>7</sup> to store these set points. Therefore, the combination of Jurgen, Volkswagen '070, and Davidian renders obvious an “RPM set point.”

Volkswagen '070 also teaches both upshift and downshift notification circuits, as upward and downward pointing arrows. When the engine is being operated at an excessive speed, an upshift notification circuit is activated. When the engine is being operated at an insufficient speed, the downshift notification circuit is activated. “Looking initially at operating range I remote from full load, *the desired output at a lower specific fuel consumption is able to be achieved after upshifting into the next higher gear*, at an operating point that lies to the left of operating range I in the diagram of Figure 1. *Accordingly, the device of the present invention generates a signal that asks the operator, i.e., normally the driver, to shift to a higher gear, which is indicated in Figure 1 by the*

<sup>7</sup> See, e.g., pages 11.25 (“On-chip microcontroller memory consists of some mix of five basic types: random access memory (RAM), read-only memory (ROM), erasable ROM (EPROM), electrically erasable ROM (EEPROM), and flash memory. RAM is typically utilized for run-time variable storage and SFRs. The various types of ROM are generally used for code storage and fixed data tables.”) and 11.29 (“Off-chip memory offers the most flexibility to the system designer. . . . Off-chip memory is flexible because the user can implement various memory devices in the configuration of his choice. Most microcontrollers on the market today offer a wide variety of control pins and timing modes to allow the system designer flexibility when interfacing to a wide range of external memory systems.”).

*upward pointing arrow within operating range I.*” Pages 6–7; “When the operating point lies in operating range II, *the device according to the present invention generates a signal that asks the driver to downshift, which is indicated by the downward pointing arrow at operating range II in Figure 1.*” Page 7. Volkswagen ’070 also teaches that the change-over switch 6 pivots either upwardly or downwardly based upon the engine speed in order to drive the upshift or downshift indicator lights. Pages 7-8. Therefore, Volkswagen ’070 teaches “an upshift[/downshift] notification circuit coupled to said processor subsystem, said upshift[/downshift] notification circuit issuing a notification that said engine of said vehicle is being operated at an excessive[/insufficient] speed” and “said processor subsystem determining, based upon data received from said plurality of sensors, . . . when to activate said upshift[/downshift] notification circuit.”

Davidian discloses an anti-collision system that includes “a front space sensor 8 for sensing the space in front of the vehicle, such as the presence of another vehicle.” Col. 4, lines 52 to 66. This front space sensor includes “a transmitter 106 and a receiver 108 for transmitting and receiving the pulses (e.g., RF, ultrasound, laser, IR, etc.) in the front space sensor 8 . . . for measuring the distance of the vehicle from objects in front of . . . the vehicle.” Col. 10, lines 17 to 26. The front space sensor taught by Davidian continuously transmits pulses (including, in one example, RF pulses) and measures “the round-trip time from the pulse transmission to the echo reception in order to determine the distance of the vehicle from the object.” Col. 10, lines 38 to 50. Therefore, Davidian teaches “a radar detector, said radar detector determining a distance separating a vehicle having an engine and an object in front of said vehicle.”

Davidian also teaches a processor subsystem, disclosed as microcomputer 4, which is illustrated in FIGS. 6a and 6b. It is coupled to the radar detector (front vehicle space sensor 8) and the vehicle speed sensor 12:

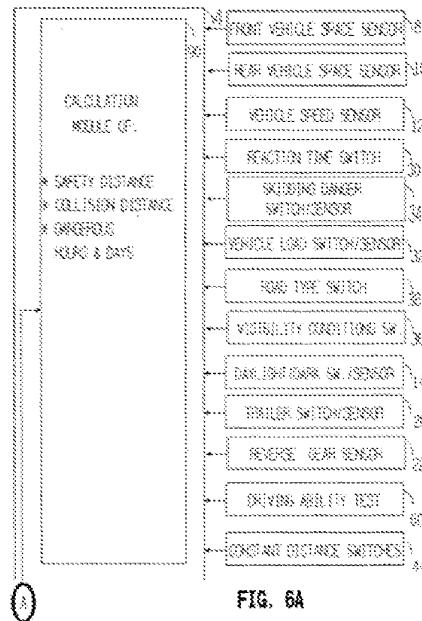

“The microcomputer 4 as illustrated in FIGS. 6a, 6b is divided into various functional modules, as follows: a calculation module 90, which receives data concerning the various parameters briefly described above.” Col. 8, lines 29 to 43. Therefore, Davidian teaches “a processor subsystem, coupled to said radar detector and said at least one sensor, to receive data therefrom.”

Davidian teaches a memory subsystem that stores a vehicle speed/stopping distance table. “*Computer module 90 also includes information about the vehicle braking distances as a function of speed. This is preferably in the form of a look-up table*, for example, provided by the manufacturer for predetermined defined conditions concerning road type, skidding danger, vehicle load and tires pressure, and is *stored in a ROM (read-only memory) of the microcomputer so that it can be changed periodically if necessary.*” Col. 9, lines 20 to 27. This memory subsystem is a part of the microcomputer 4, as illustrated in FIG. 6A. Davidian also teaches the storing of present and prior levels of each sensor in memory. For example, Davidian’s “Black Box Module” 94 stores the “time, *speed*, and *relative distance* between the vehicle and object” each time a collision alarm is activated. Col. 15, lines 22 to 26. Therefore, Davidian teaches “a memory subsystem, coupled to said processor subsystem, said memory subsystem storing a first vehicle speed/stopping distance table” and the memory subsystem storing “a present level for each one of said at least one sensor and a prior level for each one of said at least one sensor.”

Davidian teaches a vehicle proximity alarm circuit, which activates a collision alarm when a calculated "Collision Distance" is close to a calculated "Stopping Distance." "A determination is also made of the collision distance CD which is equal to the stopping distance SD divided by the collision safety factor CSF, e.g., 1.25 in the example illustrated above, such that should the distance between the vehicle and the object come within the collision distance CD, the collision alarm is then actuated." Col. 12, line 59 to col. 13, line 11. The collision alarm, may be an audio alarm or a visual alarm. Col. 9, lines 52 to 56. The determination whether to activate the collision alarm is made by the calculation module 90, which is part of the microcomputer 4. *See* col. 12, line 27 ("Operation of the Calculation Module 90"). Therefore, Davidian teaches "a vehicle proximity alarm circuit coupled to said processor subsystem, said vehicle proximity alarm circuit issuing an alarm that said vehicle is too close to said object."

Davidian also teaches that the processor subsystem determines when to activate the proximity alarm. The radar input, the vehicle speed input, and the vehicle speed/stopping distance tables are all located in the calculation module 90, which it uses to calculate stopping distance and collision distance. Col. 12, line 59 to col. 13, line 11. Therefore, Davidian teaches "said processor subsystem determining whether to activate said vehicle proximity alarm circuit based upon separation distance data received from said radar detector, vehicle speed data received from said road speed sensor and said first vehicle speed/stopping distance table stored in said memory subsystem."

Davidian also teaches the use of a rain sensor connected to module 90 to detect the presence of rain. Claim 18 requires the use of a windshield wiper sensor in order to detect if rain is present. In rejecting claim 18, the Examiner stated that "Chasteen discloses a plurality of sensors for controlling the operation of the fuel injection wherein it would have been obvious to use a windshield wiper sensor in order to provide a complete performance operation of the vehicle." August 6, 1998 Office Action, at 5. This rejection was not challenged by the applicant, and the claim was allowed due to the addition of the upshift notification circuit to claim 17. The Examiner's statement that a windshield wiper sensor would be an obvious modification to Chasteen carries equal weight in view of the rain sensor taught in Davidian.

Davidian also teaches that it would be beneficial in certain situations to take automatic control of the vehicle. Col. 2, lines 67 to col. 3, line 2. While Claim 19 requires a throttle controller that selectively reduces the throttle based upon inputs from various sensors,



the disclosure in Davidian regarding the automatic application of the brakes achieves the same result – slowing the vehicle down.<sup>8</sup>

Jurgen teaches the use of a brake sensor as claimed in Claim 20. For example, Jurgen teaches that “[p]ressure sensors are used to monitor brake fluid pressure” and that “[b]rake pedal position and brake fluid pressure information are also required for control.” Jurgen, pages 7.21 to 22. Therefore, the combination of Jurgen, Volkswagen ’070, and Davidian teaches “at least one sensor further includes a brake sensor for indicating whether a brake system of said vehicle is activated.”

Davidian also teaches the use of a “black box” to record vehicle events. Claim 21 requires a “means for counting a total number of vehicle proximity alarms determined by said processor subsystem.” Davidian teaches the use of four different counters, which are stored in the black box each time a front or rear proximity alarm is activated. Col. 11, lines 60 to 68; col. 14, lines 8 to 12. Davidian does not teach “means for selectively reducing said throttle based upon said total number of vehicle proximity alarms.” However, Davidian does teach that automated activation of a brake system is used to slow the vehicle down. Indeed, the Examiner stated that “it has been discussed that Doi et al. disclose an alarm therefore it would have been obvious to one of ordinary skill in the art at the time of the invention to count a total number of alarms associated with the system.” August 6, 1998 Office Action, at 6. Davidian teaches counting the number of vehicle proximity alarms, and also teaches the automatic control of a vehicle. Therefore, Davidian renders obvious claim 21.

A person of ordinary skill in the art, at the time the alleged inventions of claims 17–23 and 26 of the ’781 patent were made, would have found it obvious to combine the teachings of Jurgen, Volkswagen ’070, and Davidian, and, in addition, would have been motivated to do so. Indeed, Jurgen, for example, expressly describes one such motivation: “The motive for using an electronic engine control system is to provide the needed accuracy and adaptability in order to minimize exhaust emissions and fuel consumption, provide optimal driveability for all operating conditions, minimize evaporative emissions, and provide system diagnosis when malfunctions occur.” (Jurgen, Page 12.1). A person of ordinary skill in the art, at the time the alleged inventions of claims 17–23 and 26 of the ’781 patent were made would have been further motivated to combine the teachings of Jurgen, Volkswagen ’070, and Davidian, to “provide optimal driveability for all operating conditions” (Jurgen, Page 12.1), to “provide[] the fuel metering and ignition timing precision to minimize fuel

---

<sup>8</sup> Additionally, Jurgen teaches that an electronic throttle controller was known in the art.

consumption (Jurgen, Page 12.4), to “provid[e] a device that assists the operator of the internal combustion engine equipped with a conventional transmission . . . for example, in setting an operating point of the engine that is advantageous in terms of fuel consumption” (Volkswagen ’070, Page 5), and to provide an “anti-collision system for vehicles” that “computes[] the danger-of-collision distance to the object” (Davidian, Col. 1, line 7 and col. 2, lines 3 to 4). The ’781 patent states that its object is to “provide a system which integrates the ability to issue audible warnings which advise the driver to correct operation of the vehicle in a manner which will *enhance the efficient operation* thereof with the ability to automatically take corrective action *if the vehicle is being operated unsafely.*” Col. 1, line 66 to col. 2, line 5. Thus, like the ’781 patent, Jurgen, Volkswagen ’070, and Davidian are concerned with, for example, improving fuel efficiency and safety.

Furthermore, as additional evidence that a person of ordinary skill in the art would be motivated to combine the teachings of Jurgen, Volkswagen ’070, and Davidian, Jurgen describes at page xvii:

Automotive electronics as we know it today encompasses a wide variety of devices and systems. Key to them all, and those yet to come, is the ability to sense and measure accurately automotive parameters. Equally important at the output is the ability to initiate control actions accurately in response to commands. In other words, sensors and actuators are the heart of any automotive electronics application. . . .

The importance of sensors and actuators cannot be overemphasized. The future growth of automotive electronics is arguably more dependent on sufficiently accurate and low-cost sensors and actuators than on computers, controls, displays, and other technologies.

Moreover, the combination of these teachings is merely (a) the combination of prior art elements according to known methods to yield predictable results; (b) the simple substitution of known elements for one another to obtain predictable results; (c) the use of known techniques to improve similar devices in the same way; (d) the application of known techniques to known devices ready for improvement to yield predictable results; (e) obvious to try; and (f) known to work in one field of endeavor prompting variations for use in either the same field or a different one based on design incentives or other market forces since the variations are predictable to one of ordinary skill in the art.

Thus, the combination of Jurgen, Volkswagen ’070, and Davidian teaches the limitations that the Examiner concluded were absent from the prior art cited during

prosecution of the '781 patent, *i.e.*, upshift and downshift notification circuits activated by a processor in response to sensor inputs. Accordingly, a substantial new question of patentability affecting claims 17–23 and 26 is raised by the combination of Jurgen, Volkswagen '070, and Davidian.

As set forth in the appended charts, the combination of Jurgen, Volkswagen '070, and Davidian teaches all of the limitations of claims 17–23 and 26 of the '781 patent and therefore renders obvious claims 17–23 and 26 of the '781 patent. Therefore, VWGoA proposes a ground of rejection of claims 17–23 and 26 of the '781 patent under 35 U.S.C. § 103(a) as obvious in view of the combination of Jurgen, Volkswagen '070, and Davidian.

**6. Claims 17–21 and 23 are Obvious Under 35 U.S.C. § 103(a) in View of the Combination of Jurgen, Saturn '452, and Davidian**

Claims 17–21 and 23 are obvious under 35 U.S.C. § 103(a) in view of the combination of Jurgen, Saturn '452, and Davidian. Jurgen, Saturn '452, and Davidian were not cited by the Examiner or the applicants during prosecution. Therefore, the question of whether claims 17–21 and 23 are obvious in view of the combination of Jurgen, Saturn '452, and Davidian was not previously considered. The combination of Jurgen, Saturn '452, and Davidian is closer to the subject matter of claims 17–21 and 23 of the '781 patent than any prior art that was relied upon during prosecution of the '781 patent, and the combination of Jurgen, Saturn '452, and Davidian provides new, non-cumulative technical teachings that were not otherwise provided in any prior art that was relied upon during prosecution of the '781 patent.

As more fully explained above, the Examiner concluded that claims 17 and 23 were allowable over the prior art cited during prosecution on the basis that the prior art does not teach an upshift notification circuit, wherein the processor determines, based upon data received from sensors, when to activate said upshift notification circuit.

Jurgen discloses an electronic engine control system that receives sensor inputs, evaluates them, and determines the necessary outputs to provide for optimal driveability. (Jurgen, page 12.1). Jurgen also discloses that these sensors monitor engine speed (page 7.6), road speed (pages 7.8, 14.3), manifold pressure (pages 2.5, 2.7), and throttle position (page 12.21). Jurgen also teaches that the use of processor subsystems to receive inputs from these sensors was known. (Pages 12.1, 13.6, 22.6). “During the entire operating time of the vehicle, the ECUs are constantly supervising the sensors they are connected to.” (Page 22.6). Indeed, Jurgen illustrates these hardware parts:

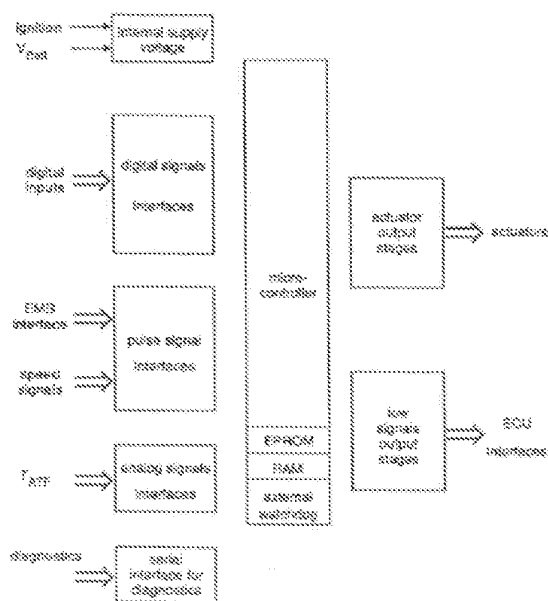

FIGURE 22.2 Overview of motor system parts.

Jurgen, therefore, teaches “a plurality of sensors coupled to a vehicle having an engine, said plurality of sensors, which collectively monitor operation of said vehicle, including a road speed sensor, an engine speed sensor, a manifold pressure sensor and a throttle position sensor” and “a processor subsystem, coupled to each one of said plurality of sensors, to receive data therefrom.”

Jurgen also discloses that a memory subsystem can be used in connection with the processor subsystem in order to store programs and data. (Page 13.5). It is disclosed that the memory can store data tables including a manifold pressure set point and an RPM set point for use by the system. (Pages 13.5 (“The memory devices for program and data are usually EPROMs”), 12.9 (“The engine load information is provided by the manifold pressure sensor . . . . The engine control unit contains data tables for combinations of load and RPM”). Additionally, present and prior levels of each sensor are stored in the memory for diagnostic use, which preserves sensor outputs for later use. (Pages 14.2, 22.2 to 22.3). Jurgen, therefore, teaches “a memory subsystem, coupled to said processor subsystem, said memory subsystem storing therein a manifold pressure set point, an RPM set point, and present and prior levels for each one of said plurality of sensors.”

Jurgen teaches a fuel overinjection notification circuit, which issues a notification that excessive fuel is being supplied to the engine of the vehicle. For example, the ECU taught by Jurgen can shut off fuel in certain situations by evaluating the throttle position, engine RPM, and vehicle speed. (Page 12.4). Additionally, the ECU can shut off fuel injectors when a

maximum speed is achieved (page 12.14). The ECU provides the fuel overinjection notification to the fuel injectors when a fuel cutoff state is reached. Jurgen, therefore, teaches “a fuel overinjection notification circuit coupled to said processor subsystem, said fuel overinjection notification circuit issuing a notification that excessive fuel is being supplied to said engine of said vehicle.”

Jurgen also teaches that the transmission can be controlled by calculating the necessary shift points based upon throttle position, the accelerator pedal position (e.g., throttle position), and the vehicle speed. (Page 13.9). “The shift point limitations are made, on the one hand, by the highest admissible engine speed for each application.” *Id.* The TCU (transmission control unit) stores shift maps that provide notifications to the transmission regarding whether and when to shift. (Page 13.14). Jurgen, therefore, teaches “an upshift notification circuit coupled to said processor subsystem, said upshift notification circuit issuing a notification that said engine of said vehicle is being operated at an excessive speed.”

Jurgen teaches “said processor subsystem determining, based upon data received from said plurality of sensors, when to activate said fuel overinjection circuit and when to activate said upshift/downshift notification circuit.” For example, the combination of the ECU, which monitors all of the vehicle’s sensors (see above) and the TCU, which stores the shift maps, can send notification circuits to the fuel injectors and/or the transmission in order to alleviate a fuel overinjection condition or shift the engine.

Saturn ’452 teaches a “means for indicating to the operator a point in operation for upshifting to the next higher gear.” Abstract. The processor subsystem taught by Saturn ’452 receives sensor inputs that sense manifold pressure, engine speed, and throttle position. Col. 2, lines 42 to 44; col. 7, lines 13 to 21. Therefore, Saturn ’452 teaches “a plurality of sensors coupled to a vehicle having an engine, said plurality of sensors, which collectively monitor operation of said vehicle, including a road speed sensor, an engine speed sensor, a manifold pressure sensor and a throttle position sensor,” except for the claimed road speed sensor, which is taught by Jurgen.

Figure 1 of Saturn ’452 is illustrative:

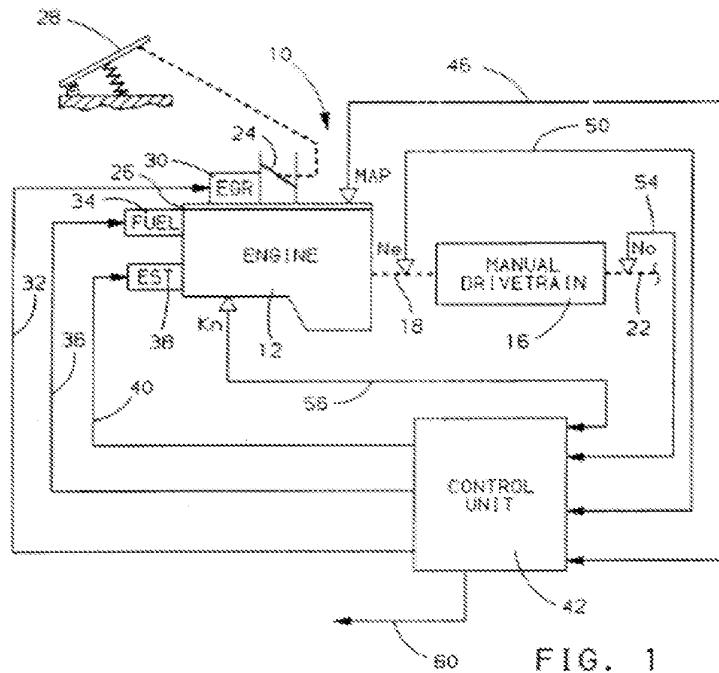

Figure 1 of Saturn '452 teaches that the control unit 42 is connected to the sensor inputs, and outputs a signal on line 60 that may drive a lamp "for indicating the state of the upshift indicator light." Col. 2, lines 42 to 55; col. 3, lines 60 to 65. Additionally, Saturn '452 teaches that the control unit includes a memory (col. 2, lines 52 to 55), and that a "predetermined maximum allowable engine speed threshold K1" is used by the system. Col. 6, lines 55 to 60. Therefore, Saturn '452 discloses "a memory subsystem, coupled to said processor subsystem, said memory subsystem storing therein a manifold pressure set point, an RPM set point, and present and prior levels for each one of said plurality of sensors," except for the claimed manifold pressure set point and present and prior levels for each one of the sensors, which are taught in Jurgan (*see* Jurgan at 12.9, 13.5).

Saturn '452 teaches an upshift notification circuit connected to the control unit, which indicates "via line 60 the state of an upshift indicator light or equivalent visual display." Col. 2, lines 42 to 55. Therefore, Saturn '452 teaches "an upshift notification circuit coupled to said processor subsystem, said upshift notification circuit issuing a notification that said engine of said vehicle is being operated at an excessive speed" and "said processor subsystem determining, based upon data received from said plurality of sensors, . . . when to activate said upshift notification circuit."

Davidian discloses an anti-collision system that includes “a front space sensor 8 for sensing the space in front of the vehicle, such as the presence of another vehicle.” Col. 4, lines 52 to 66. This front space sensor includes “a transmitter 106 and a receiver 108 for transmitting and receiving the pulses (e.g., RF, ultrasound, laser, IR, etc.) in the front space sensor 8 . . . for measuring the distance of the vehicle from objects in front of . . . the vehicle.” Col. 10, lines 17 to 26. The front space sensor in Davidian continuously transmits pulses (including, in one example, RF pulses) and measures “the round-trip time from the pulse transmission to the echo reception in order to determine the distance of the vehicle from the object.” Col. 10, lines 38 to 50. Therefore, Davidian teaches “a radar detector, said radar detector determining a distance separating a vehicle having an engine and an object in front of said vehicle.”

Davidian also teaches a processor subsystem, disclosed as microcomputer 4, which is illustrated in FIGS. 6a and 6b. It is coupled to the radar detector (front vehicle space sensor 8) and the vehicle speed sensor 12:

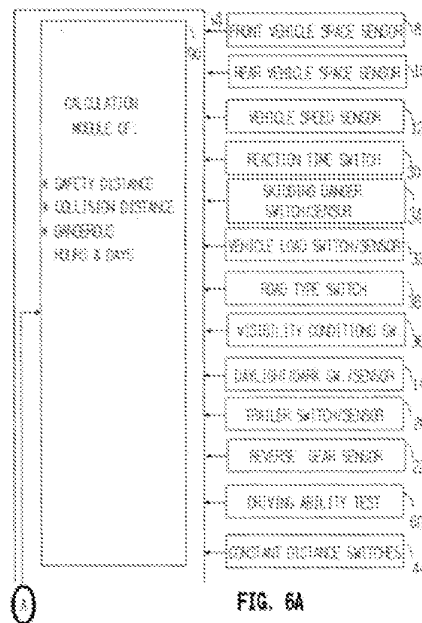

FIG. 6A

“The microcomputer 4 as illustrated in FIGS. 6a, 6b is divided into various functional modules, as follows: a calculation module 90, which receives data concerning the various parameters briefly described above.” Col. 8, lines 29 to 43. Therefore, Davidian teaches “a processor subsystem, coupled to said radar detector and said at least one sensor, to receive data therefrom.”

Davidian teaches a memory subsystem that stores a vehicle speed/stopping distance table. “*Computer module 90 also includes information about the vehicle braking distances as a function of speed. This is preferably in the form of a look-up table*, for example, provided by the manufacturer for predetermined defined conditions concerning road type, skidding danger, vehicle load and tires pressure, and is *stored in a ROM (read-only memory) of the microcomputer so that it can be changed periodically if necessary.*” Col. 9, lines 20 to 27. This memory subsystem is a part of the microcomputer 4, as illustrated in FIG. 6A. Davidian also teaches the storing of present and prior levels of each sensor in memory. For example, Davidian’s “Black Box Module” 94 stores the “time, *speed*, and *relative distance* between the vehicle and object” each time a collision alarm is activated. Col. 15, lines 22 to 26. Therefore, Davidian teaches “a memory subsystem, coupled to said processor subsystem, said memory subsystem storing a first vehicle speed/stopping distance table” and the memory subsystem storing “a present level for each one of said at least one sensor and a prior level for each one of said at least one sensor.”

Davidian teaches a vehicle proximity alarm circuit, which activates a collision alarm when a calculated “Collision Distance” is close to a calculated “Stopping Distance.” “A determination is also made of the collision distance CD which is equal to the stopping distance SD divided by the collision safety factor CSF, e.g., 1.25 in the example illustrated above, such that should the distance between the vehicle and the object come within the collision distance CD, the collision alarm is then actuated.” Col. 12, line 59 to col. 13, line 11. The collision alarm, may be an audio alarm or a visual alarm. Col. 9, lines 52 to 56. The determination whether to activate the collision alarm is made by the calculation module 90, which is part of the microcomputer 4. *See* col. 12, line 27 (“Operation of the Calculation Module 90”). Therefore, Davidian teaches “a vehicle proximity alarm circuit coupled to said processor subsystem, said vehicle proximity alarm circuit issuing an alarm that said vehicle is too close to said object.”

Davidian also teaches that the processor subsystem determines when to activate the proximity alarm. The radar input, the vehicle speed input, and the vehicle speed/stopping distance tables are all located in the calculation module 90, which it uses to calculate stopping distance and collision distance. Col. 12, line 59 to col. 13, line 11. Therefore, Davidian teaches “said processor subsystem determining whether to activate said vehicle proximity alarm circuit based upon separation distance data received from said radar detector, vehicle speed data received from said road speed sensor and said first vehicle speed/stopping distance table stored in said memory subsystem.”



Davidian also teaches the use of a rain sensor connected to module 90 to detect the presence of rain. Claim 18 requires the use of a windshield wiper sensor in order to detect if rain is present. In rejecting claim 18, the Examiner stated that “Chasteen discloses a plurality of sensors for controlling the operation of the fuel injection wherein it would have been obvious to use a windshield wiper sensor in order to provide a complete performance operation of the vehicle.” August 6, 1998 Office Action, at 5. This rejection was not challenged by the applicant, and the claim was allowed due to the addition of the upshift notification circuit to claim 17. The Examiner’s statement that a windshield wiper sensor would be an obvious modification to Chasteen carries equal weight in view of the rain sensor taught in Davidian.

Davidian also teaches that it would be beneficial in certain situations to take automatic control of the vehicle. Col. 2, lines 67 to col. 3, line 2. While Claim 19 requires a throttle controller that selectively reduces the throttle based upon inputs from various sensors, the disclosure in Davidian regarding the automatic application of the brakes achieves the same result – slowing the vehicle down.<sup>9</sup>

Jurgen teaches the use of a brake sensor as claimed in Claim 20. For example, Jurgen teaches that “[p]ressure sensors are used to monitor brake fluid pressure” and that “[b]rake pedal position and brake fluid pressure information are also required for control.” Jurgen, pages 7.21 to 22. Therefore, the combination of Jurgen, Saturn ’452, and Davidian teaches “at least one sensor further includes a brake sensor for indicating whether a brake system of said vehicle is activated.”

Davidian also teaches the use of a “black box” to record vehicle events. Claim 21 requires a “means for counting a total number of vehicle proximity alarms determined by said processor subsystem.” Davidian teaches the use of four different counters, which are stored in the black box each time a front or rear proximity alarm is activated. Col. 11, lines 60 to 68; col. 14, lines 8 to 12. Davidian does not teach “means for selectively reducing said throttle based upon said total number of vehicle proximity alarms.” However, Davidian does teach that automated activation of a brake system is used to slow the vehicle down. Indeed, the Examiner stated that “it has been discussed that Doi et al. disclose an alarm therefore it would have been obvious to one of ordinary skill in the art at the time of the invention to count a total number of alarms associated with the system.” August 6, 1998 Office Action, at

---

<sup>9</sup> Additionally, Jurgen teaches that an electronic throttle controller was known in the art.

6. Davidian teaches counting the number of vehicle proximity alarms, and also teaches the automatic control of a vehicle. Therefore, Davidian renders obvious claim 21.

A person of ordinary skill in the art, at the time the alleged inventions of claims 17–21 and 23 of the '781 patent were made, would have found it obvious to combine the teachings of Jurgen, Saturn '452, and Davidian, and, in addition, would have been motivated to do so. Indeed, Jurgen, for example, expressly describes one such motivation: “The motive for using an electronic engine control system is to provide the needed accuracy and adaptability in order to minimize exhaust emissions and fuel consumption, provide optimal driveability for all operating conditions, minimize evaporative emissions, and provide system diagnosis when malfunctions occur.” (Jurgen, Page 12.1). A person of ordinary skill in the art, at the time the alleged inventions of claims 17–21 and 23 of the '781 patent were made would have been further motivated to combine the teachings of Jurgen, Saturn '452, and Davidian, to “provide[] the fuel metering and ignition timing precision to minimize fuel consumption (Jurgen, Page 12.4), to provide a “means for indicating to the operator a point in operation for upshifting to the next higher gear” (Saturn '452, Abstract), to provide “an improved method of determining shift points and indicating the same to a vehicle operator in order to maximize real driving fuel economy” (Saturn '452, col. 1, lines 44 to 47), and to provide an “anti-collision system for vehicles” that “computes[] the danger-of-collision distance to the object” (Davidian, Col. 1, line 7 and col. 2, lines 3 to 4). The '781 patent states that its object is to “provide a system which integrates the ability to issue audible warnings which advise the driver to correct operation of the vehicle in a manner which will *enhance the efficient operation* thereof with the ability to automatically take corrective action *if the vehicle is being operated unsafely.*” Col. 1, line 66 to col. 2, line 5. Thus, like the '781 patent, Jurgen, Saturn '452, and Davidian are concerned with, for example, improving fuel efficiency and safety.

Furthermore, as additional evidence that a person of ordinary skill in the art would be motivated to combine the teachings of Jurgen, Saturn '452, and Davidian, Jurgen describes at page xvii:

Automotive electronics as we know it today encompasses a wide variety of devices and systems. Key to them all, and those yet to come, is the ability to sense and measure accurately automotive parameters. Equally important at the output is the ability to initiate control actions accurately in response to commands. In other words, sensors and actuators are the heart of any automotive electronics application. . . .

The importance of sensors and actuators cannot be overemphasized. The future growth of automotive electronics is arguably more dependent on sufficiently accurate and low-cost sensors and actuators than on computers, controls, displays, and other technologies.

Moreover, the combination of these teachings is merely (a) the combination of prior art elements according to known methods to yield predictable results; (b) the simple substitution of known elements for one another to obtain predictable results; (c) the use of known techniques to improve similar devices in the same way; (d) the application of known techniques to known devices ready for improvement to yield predictable results; (e) obvious to try; and (f) known to work in one field of endeavor prompting variations for use in either the same field or a different one based on design incentives or other market forces since the variations are predictable to one of ordinary skill in the art.

Thus, the combination of Jurgen, Saturn '452, and Davidian teaches the limitations that the Examiner concluded were absent from the prior art cited during prosecution of the '781 patent, *i.e.*, an upshift notification circuit activated by a processor in response to sensor inputs. Accordingly, a substantial new question of patentability affecting claims 17–21 and 23 is raised by the combination of Jurgen, Saturn '452, and Davidian.

As set forth in the appended charts, the combination of Jurgen, Saturn '452, and Davidian teaches all of the limitations of claims 17–21 and 23 of the '781 patent and therefore renders obvious claims 17–21 and 23 of the '781 patent. Therefore, VWGoA proposes a ground of rejection of claims 17–21 and 23 of the '781 patent under 35 U.S.C. § 103(a) as obvious in view of the combination of Jurgen, Saturn '452, and Davidian.

#### **7. Claims 28–30 are Obvious Under 35 U.S.C. § 103(a) in View of the Combination of Jurgen and Nissan '055**

Claims 28–30 are obvious under 35 U.S.C. § 103(a) in view of the combination of Jurgen and Nissan '055. Neither Jurgen nor Nissan '055 was cited by the Examiner or the applicants during prosecution of the '781 patent. Therefore, the question of whether claims 28–30 are obvious in view of the combination of Jurgen and Nissan '055 was not previously considered. The combination of Jurgen and Nissan '055 is closer to the subject matter of claims 28–30 of the '781 patent than any prior art that was relied upon during prosecution of the '781 patent, and the combination of Jurgen and Nissan '055 provides new, non-cumulative technical teachings that were not otherwise provided in any prior art that was relied upon during prosecution of the '781 patent.

As more fully explained above, the applicants asserted that claim 28 was allowable over the prior art because the prior art does not disclose a fuel overinjection notification circuit that is activated based on three sensors: a road speed sensor, a throttle position sensor, and a manifold pressure sensor.

Jurgen discloses an electronic engine control system that receives sensor inputs, evaluates them, and determines the necessary outputs to provide for optimal driveability. (Jurgen, page 12.1). Jurgen also discloses that these sensors monitor engine speed (page 7.6), road speed (pages 7.8, 14.3), manifold pressure (pages 2.5, 2.7), and throttle position (page 12.21). Jurgen also teaches that the use of processor subsystems to receive inputs from these sensors was known. (Pages 12.1, 13.6, 22.6). “During the entire operating time of the vehicle, the ECUs are constantly supervising the sensors they are connected to.” (Page 22.6). Indeed, Jurgen illustrates these hardware parts:

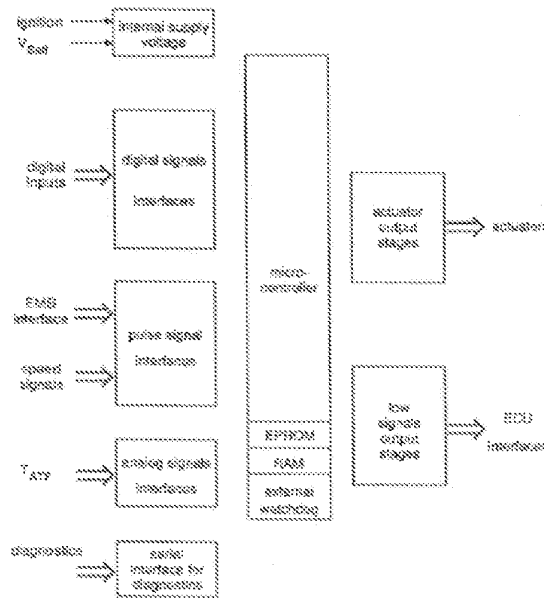

FIGURE 33.1 Composition of hardware parts.

Jurgen, therefore, teaches “a plurality of sensors coupled to a vehicle having an engine, said plurality of sensors, which collectively monitor operation of said vehicle, including a road speed sensor, a manifold pressure sensor and a throttle position sensor” and “a processor subsystem, coupled to each one of said plurality of sensors, to receive data therefrom.”

Jurgen teaches a fuel overinjection notification circuit, which issues a notification that excessive fuel is being supplied to the engine of the vehicle. For example, the ECU disclosed in Jurgen can shut off fuel in certain situations by evaluating the throttle position, engine

RPM, and vehicle speed. (Page 12.4). Additionally, the ECU can shut off fuel injectors when a maximum speed is achieved (page 12.14). The ECU provides the fuel overinjection notification to the fuel injectors when a fuel cutoff state is reached. Jurgen, therefore, teaches “a fuel overinjection notification circuit coupled to said processor subsystem, said fuel overinjection notification circuit issuing a notification that excessive fuel is being supplied to said engine of said vehicle.”

Jurgen teaches “said processor subsystem determining, based upon data received from said plurality of sensors, when to activate said fuel overinjection circuit and when to activate said upshift/downshift notification circuit.” For example, the combination of the ECU, which monitors all of the vehicle’s sensors (see above) and the TCU, which stores the shift maps, can send notification circuits to the fuel injectors and/or the transmission in order to alleviate a fuel overinjection condition or shift the engine.

Nissan ’055 discloses a control system that “controls the number of fuel injected cylinders” in order to increase fuel economy. Abstract. Figure 1 of Nissan ’055 discloses that a throttle opening sensor and vehicle velocity sensor are inputs to the system:

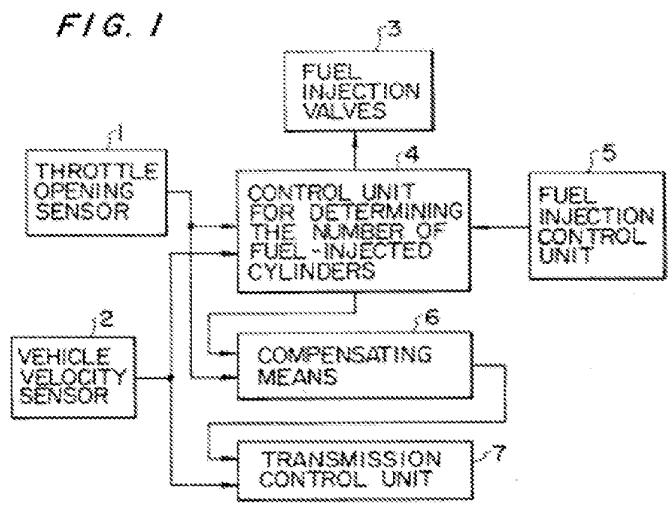

Nissan ’055 teaches that “when the signal from the vehicle velocity sensor 2 exceeds a predetermined level and at the same time the signal from the throttle opening sensor 1 falls below another predetermined level, the control unit 4 determines the number of cylinders to which fuel is actually injected based on the two signals applied and stops injection of fuel to specified one or more cylinders.” Col. 2, lines 59 to 66. Therefore, Nissan ’055 teaches “a fuel overinjection notification circuit coupled to said processor subsystem, said fuel overinjection notification circuit issuing a notification that excessive fuel is being supplied to

said engine of said vehicle.” Although Nissan ’055 does not refer to the use of a manifold pressure sensor, manifold pressure sensors are taught by Jurgen. Therefore, the combination of Jurgen and Nissan ’055 teaches “said processor subsystem determining whether to activate said fuel overinjection notification sensor based upon data received from said road speed sensor, said throttle position sensor and said manifold pressure sensor.”

Claims 29 and 30 require the fuel overinjection notification circuit to be activated when certain conditions measured by the claimed sensors are either increasing or decreasing. For example, claim 29 requires the fuel overinjection notification circuit to be activated when it is determined that (1) road speed is increasing; (2) throttle position is increasing; and (3) the manifold pressure exceeds a manifold pressure set point. In the remarks that were presented with these claims, the Applicant stated as follows:

Specifically, as presented in new Claims 34-36, Applicants’ claimed apparatus for optimizing operation of a vehicle includes a fuel overinjection notification circuit and a processor subsystem which determines when to activate the fuel overinjection notification circuit. The processor makes that determination based upon data received from specifically recited sensors, including the road speed sensor.

February 16, 1999 Amendment, page 11 (emphasis in original).

In allowing these claims, the Examiner stated that the prior art does not disclose that the processor subsystem determines “whether to activate the fuel overinjection notification circuit based upon data received from the road speed sensor, the throttle position sensor and the manifold sensor.” April 22, 1999 Notice of Allowability, at 3. The combination of Jurgen and Nissan ’055 teaches the use of road speed, throttle position, and manifold pressure sensors, and also teaches that a fuel overinjection notification circuit can be activated based upon input from these sensors. *See* Jurgen, page 12.22; Nissan ’055, col. 2, lines 59 to 66.

A person of ordinary skill in the art, at the time the alleged inventions of claims 28–30 of the ’781 patent were made, would have found it obvious to combine the teachings of Jurgen and Nissan ’055, and, in addition, would have been motivated to do so. Indeed, Jurgen, for example, expressly describes one such motivation: “The motive for using an electronic engine control system is to provide the needed accuracy and adaptability in order to minimize exhaust emissions and fuel consumption, provide optimal driveability for all operating conditions, minimize evaporative emissions, and provide system diagnosis when malfunctions occur.” (Jurgen, Page 12.1). A person of ordinary skill in the art, at the time the alleged inventions of claims 28–30 of the ’781 patent were made would have been further motivated to combine the teachings of Jurgen and Nissan ’055, to “provide optimal

driveability for all operating conditions” (Jurgen, Page 12.1), to “provide[] the fuel metering and ignition timing precision to minimize fuel consumption (Jurgen, Page 12.4), and to “increas[e] fuel economy” (Nissan ’055, Abstract). The ’781 patent states that its object is to “provide a system which integrates the ability to issue audible warnings which advise the driver to correct operation of the vehicle in a manner which will *enhance the efficient operation* thereof with the ability to automatically take corrective action if the vehicle is being operated unsafely.” Col. 1, line 66 to col. 2, line 5. Thus, like the ’781 patent, Jurgen and Nissan ’055 are concerned with, for example, improving fuel efficiency.

Furthermore, as additional evidence that a person of ordinary skill in the art would be motivated to combine the teachings of Jurgen and Nissan ’055, Jurgen describes at page xvii:

Automotive electronics as we know it today encompasses a wide variety of devices and systems. Key to them all, and those yet to come, is the ability to sense and measure accurately automotive parameters. Equally important at the output is the ability to initiate control actions accurately in response to commands. In other words, sensors and actuators are the heart of any automotive electronics application. . . .

The importance of sensors and actuators cannot be overemphasized. The future growth of automotive electronics is arguably more dependent on sufficiently accurate and low-cost sensors and actuators than on computers, controls, displays, and other technologies.

Moreover, the combination of these teachings is merely (a) the combination of prior art elements according to known methods to yield predictable results; (b) the simple substitution of known elements for one another to obtain predictable results; (c) the use of known techniques to improve similar devices in the same way; (d) the application of known techniques to known devices ready for improvement to yield predictable results; (e) obvious to try; and (f) known to work in one field of endeavor prompting variations for use in either the same field or a different one based on design incentives or other market forces since the variations are predictable to one of ordinary skill in the art.

Thus, the combination of Jurgen and Nissan ’055 teaches the limitations that the applicants asserted were absent from the prior art cited during prosecution of the ’781 patent, *i.e.*, a fuel overinjection notification circuit that is activated based on three sensors: a road speed sensor, a throttle position sensor, and a manifold pressure sensor. Accordingly, a substantial new question of patentability affecting claim 28 is raised by the combination of Jurgen and Nissan ’055.

As set forth in the appended charts, the combination of Jurgen and Nissan '055 teaches all of the limitations of claims 28–30 of the '781 patent and therefore renders obvious claims 28–30 of the '781 patent. Therefore, VWGoA proposes a ground of rejection of claims 28–30 of the '781 patent under 35 U.S.C. § 103(a) as obvious in view of the combination of Jurgen and Nissan '055.

**8. Claims 28–30 are Obvious Under 35 U.S.C. § 103(a) in View of the Combination of Jurgen and Mack '324**

Claims 28–30 are obvious under 35 U.S.C. § 103(a) in view of the combination of Jurgen and Mack '324. Neither Jurgen nor Mack '324 was cited by the Examiner or the applicants during prosecution of the '781 patent. Therefore, the question of whether claims 28–30 are obvious in view of the combination of Jurgen and Mack '324 was not previously considered. The combination of Jurgen and Mack '324 is closer to the subject matter of claims 28–30 of the '781 patent than any prior art that was relied upon during prosecution of the '781 patent, and the combination of Jurgen and Mack '324 provides new, non-cumulative technical teachings that were not otherwise provided in any prior art that was relied upon during prosecution of the '781 patent.

As more fully explained above, the Applicant asserted that claim 28 was allowable over the prior art on the basis that the prior art does not disclose a fuel overinjection notification circuit that is activated based on three sensors: a road speed sensor, a throttle position sensor, and a manifold pressure sensor.

Jurgen discloses an electronic engine control system that receives sensor inputs, evaluates them, and determines the necessary outputs to provide for optimal driveability. (Jurgen, page 12.1). Jurgen also discloses that these sensors monitor engine speed (page 7.6), road speed (pages 7.8, 14.3), manifold pressure (pages 2.5, 2.7), and throttle position (page 12.21). Jurgen also teaches that the use of processor subsystems to receive inputs from these sensors was known. (Pages 12.1, 13.6, 22.6). “During the entire operating time of the vehicle, the ECUs are constantly supervising the sensors they are connected to.” (Page 22.6). Indeed, Jurgen illustrates these hardware parts:



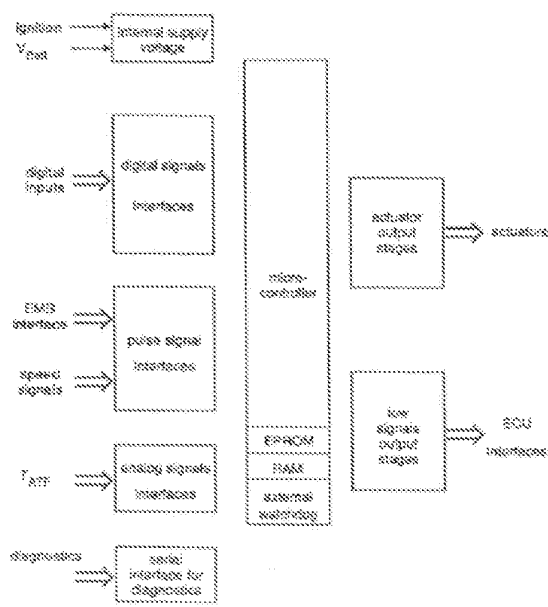

FIGURE 22.2 Overview of bus system parts.

Jurgen, therefore, teaches “a plurality of sensors coupled to a vehicle having an engine, said plurality of sensors, which collectively monitor operation of said vehicle, including a road speed sensor, a manifold pressure sensor and a throttle position sensor” and “a processor subsystem, coupled to each one of said plurality of sensors, to receive data therefrom.”

Jurgen teaches a fuel overinjection notification circuit, which issues a notification that excessive fuel is being supplied to the engine of the vehicle. For example, the ECU taught by Jurgen can shut off fuel in certain situations by evaluating the throttle position, engine RPM, and vehicle speed. (Page 12.4). Additionally, the ECU can shut off fuel injectors when a maximum speed is achieved (page 12.14). The ECU provides the fuel overinjection notification to the fuel injectors when a fuel cutoff state is reached. Jurgen, therefore, teaches “a fuel overinjection notification circuit coupled to said processor subsystem, said fuel overinjection notification circuit issuing a notification that excessive fuel is being supplied to said engine of said vehicle.”

Jurgen teaches “said processor subsystem determining, based upon data received from said plurality of sensors, when to activate said fuel overinjection circuit and when to activate said upshift/downshift notification circuit.” For example, the combination of the ECU, which monitors all of the vehicle’s sensors (see above) and the TCU, which stores the shift maps, can send notification circuits to the fuel injectors and/or the transmission in order to alleviate a fuel overinjection condition or shift the engine.

Mack '324 discloses an engine and vehicle management and control system. Abstract. Figure 1 of Mack '324 illustrates an overview of the system:

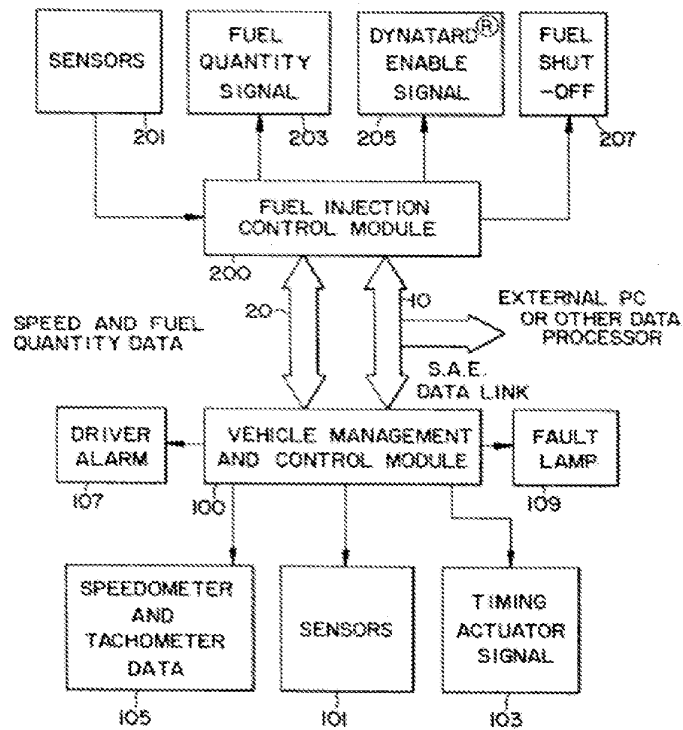

The fuel injection control module 200 in Mack '324 contains a microprocessor 2001, and receives inputs from sensors 201 and outputs a fuel quantity signal 203 and a fuel shut-off enable signal 207. Col. 2, lines 33 to 27. Figure 3 illustrates the details of the fuel injection control module:

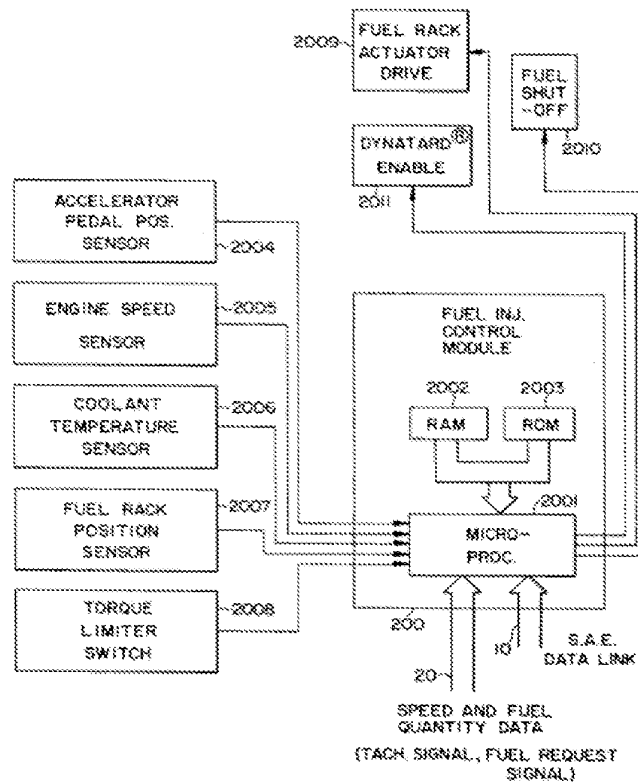

Inputs to the fuel injection control module include sensor inputs from “an accelerator pedal position sensor 2005, an engine speed sensor 2005, a coolant temperature sensor 2006, a fuel rack position sensor 2007, and a torque limiter switch 2008.” Col. 3, lines 57 to 61. Mack '324 teaches a fuel overinjection notification signal that stops fuel being injected to the engine when certain overspeed conditions are met. Col. 6, lines 24 to 53. The fuel request signal is sent by the fuel injection control module, to which the sensors are input. Therefore, Mack '324 teaches “a fuel overinjection notification circuit coupled to said processor subsystem, said fuel overinjection notification circuit issuing a notification that excessive fuel is being supplied to said engine of said vehicle.” Although Mack '324 does not refer to the use of a manifold pressure sensor, manifold pressure sensors are taught by Jurgen. Therefore, the combination of Jurgen and Mack '324 teaches “said processor subsystem determining whether to activate said fuel overinjection notification sensor based upon data received from said road speed sensor, said throttle position sensor and said manifold pressure sensor.”

Claims 29 and 30 require the fuel overinjection notification circuit to be activated when certain conditions measured by the claimed sensors are either increasing or decreasing. For example, claim 29 requires the fuel overinjection notification circuit to be activated when

it is determined that (1) road speed is increasing; (2) throttle position is increasing; and (3) the manifold pressure exceeds a manifold pressure set point. In the remarks that were presented with these claims, the Applicant stated as follows:

Specifically, as presented in new Claims 34-36, Applicants' claimed apparatus for optimizing operation of a vehicle includes a fuel overinjection notification circuit and a processor subsystem which determines when to activate the fuel overinjection notification circuit. The processor makes that determination based upon data received from specifically recited sensors, including the road speed sensor.

February 16, 1999 Amendment, page 11 (emphasis in original).

In allowing these claims, the Examiner stated that the prior art does not disclose that the processor subsystem determines "whether to activate the fuel overinjection notification circuit based upon data received from the road speed sensor, the throttle position sensor and the manifold sensor." April 22, 1999 Notice of Allowability, at 3. The combination of Jurgen and Mack '324 teaches the use of road speed, throttle position, and manifold pressure sensors, and also teaches that a fuel overinjection notification circuit can be activated based upon input from these sensors. *See* Jurgen, page 12.22; Mack '324, col. 6, lines 24 to 53.

A person of ordinary skill in the art, at the time the alleged inventions of claims 28–30 of the '781 patent were made, would have found it obvious to combine the teachings of Jurgen and Mack '324, and, in addition, would have been motivated to do so. Indeed, Jurgen, for example, expressly describes one such motivation: "The motive for using an electronic engine control system is to provide the needed accuracy and adaptability in order to minimize exhaust emissions and fuel consumption, provide optimal driveability for all operating conditions, minimize evaporative emissions, and provide system diagnosis when malfunctions occur." (Jurgen, Page 12.1). A person of ordinary skill in the art, at the time the alleged inventions of claims 28–30 of the '781 patent were made would have been further motivated to combine the teachings of Jurgen and Mack '324, to "provide[] the fuel metering and ignition timing precision to minimize fuel consumption (Jurgen, Page 12.4), and to provide for "optimization in terms of fuel economy" (Mack '324, col. 1, line 24). The '781 patent states that its object is to "provide a system which integrates the ability to issue audible warnings which advise the driver to correct operation of the vehicle in a manner which will *enhance the efficient operation* thereof with the ability to automatically take corrective action if the vehicle is being operated unsafely." Col. 1, line 66 to col. 2, line 5. Thus, like the '781 patent, Jurgen and Mack '324 are concerned with, for example, improving fuel efficiency.

Furthermore, as additional evidence that a person of ordinary skill in the art would be motivated to combine the teachings of Jurgen and Mack '324, Jurgen describes at page xvii

Automotive electronics as we know it today encompasses a wide variety of devices and systems. Key to them all, and those yet to come, is the ability to sense and measure accurately automotive parameters. Equally important at the output is the ability to initiate control actions accurately in response to commands. In other words, sensors and actuators are the heart of any automotive electronics application. . . .

The importance of sensors and actuators cannot be overemphasized. The future growth of automotive electronics is arguably more dependent on sufficiently accurate and low-cost sensors and actuators than on computers, controls, displays, and other technologies.

Moreover, the combination of these teachings is merely (a) the combination of prior art elements according to known methods to yield predictable results; (b) the simple substitution of known elements for one another to obtain predictable results; (c) the use of known techniques to improve similar devices in the same way; (d) the application of known techniques to known devices ready for improvement to yield predictable results; (e) obvious to try; and (f) known to work in one field of endeavor prompting variations for use in either the same field or a different one based on design incentives or other market forces since the variations are predictable to one of ordinary skill in the art.

Thus, the combination of Jurgen and Mack '324 teaches the limitations that the applicants asserted were absent from the prior art cited during prosecution of the '781 patent, *i.e.*, a fuel overinjection notification circuit that is activated based on three sensors: a road speed sensor, a throttle position sensor, and a manifold pressure sensor. Accordingly, a substantial new question of patentability affecting claims 28–30 is raised by the combination of Jurgen and Mack '324.

As set forth in the appended charts, the combination of Jurgen and Mack '324 teaches all of the limitations of claims 28–30 of the '781 patent and therefore renders obvious claims 28–30 of the '781 patent. Therefore, VWGoA proposes a ground of rejection of claims 28–30 of the '781 patent under 35 U.S.C. § 103(a) as obvious in view of the combination of Jurgen and Mack '324.

**9. Claims 28–30 are Obvious Under 35 U.S.C. § 103(a) in View of the Combination of Jurgen and GM '753**

Claims 28–30 are obvious under 35 U.S.C. § 103(a) in view of the combination of Jurgen and GM '753. Neither Jurgen nor GM '753 was cited by the Examiner or the applicants during prosecution. Therefore, the question of whether claims 28–30 are obvious in view of the combination of Jurgen and GM '753 was not previously considered. The combination of Jurgen and GM '753 is closer to the subject matter of claims 28–30 of the '781 patent than any prior art that was relied upon during prosecution of the '781 patent, and the combination of Jurgen and GM '753 provides new, non-cumulative technical teachings that were not otherwise provided in any prior art that was relied upon during prosecution of the '781 patent.

As more fully explained above, the applicants asserted that claim 28 was allowable over the prior art on the basis that the prior art does not disclose a fuel overinjection notification circuit that is activated based on three sensors: a road speed sensor, a throttle position sensor, and a manifold pressure sensor.

Jurgen discloses an electronic engine control system that receives sensor inputs, evaluates them, and determines the necessary outputs to provide for optimal driveability. (Jurgen, page 12.1). Jurgen also discloses that these sensors monitor engine speed (page 7.6), road speed (pages 7.8, 14.3), manifold pressure (pages 2.5, 2.7), and throttle position (page 12.21). Jurgen also teaches that the use of processor subsystems to receive inputs from these sensors was known. (Pages 12.1, 13.6, 22.6). “During the entire operating time of the vehicle, the ECUs are constantly supervising the sensors they are connected to.” (Page 22.6). Indeed, Jurgen illustrates these hardware parts:

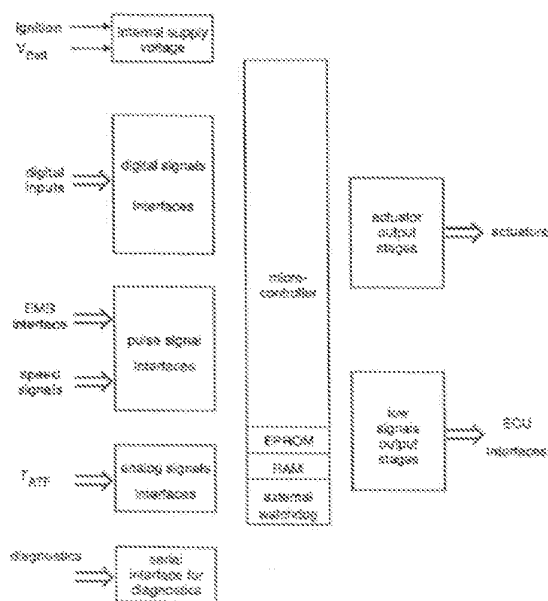

FIGURE 12.3 Overview of bus system parts.

Jurgen, therefore, teaches “a plurality of sensors coupled to a vehicle having an engine, said plurality of sensors, which collectively monitor operation of said vehicle, including a road speed sensor, a manifold pressure sensor and a throttle position sensor” and “a processor subsystem, coupled to each one of said plurality of sensors, to receive data therefrom.”

Jurgen teaches a fuel overinjection notification circuit, which issues a notification that excessive fuel is being supplied to the engine of the vehicle. For example, the ECU taught by Jurgen can shut off fuel in certain situations by evaluating the throttle position, engine RPM, and vehicle speed. (Page 12.4). Additionally, the ECU can shut off fuel injectors when a maximum speed is achieved (page 12.14). The ECU provides the fuel overinjection notification to the fuel injectors when a fuel cutoff state is reached. Jurgen, therefore, teaches “a fuel overinjection notification circuit coupled to said processor subsystem, said fuel overinjection notification circuit issuing a notification that excessive fuel is being supplied to said engine of said vehicle.”

Jurgen teaches “said processor subsystem determining, based upon data received from said plurality of sensors, when to activate said fuel overinjection circuit and when to activate said upshift/downshift notification circuit.” For example, the combination of the ECU, which monitors all of the vehicle’s sensors (see above) and the TCU, which stores the shift maps, can send notification circuits to the fuel injectors and/or the transmission in order to alleviate a fuel overinjection condition or shift the engine.

GM '753 discloses “a warning system for providing an indication when the fuel consumption of a throttle controlled vehicle having an internal combustion engine with an intake manifold exceeds pre-established levels.” Abstract. Figure 1 of GM '753 provides an overview of the system, which includes a manifold pressure sensor and a vehicle speed sensor:

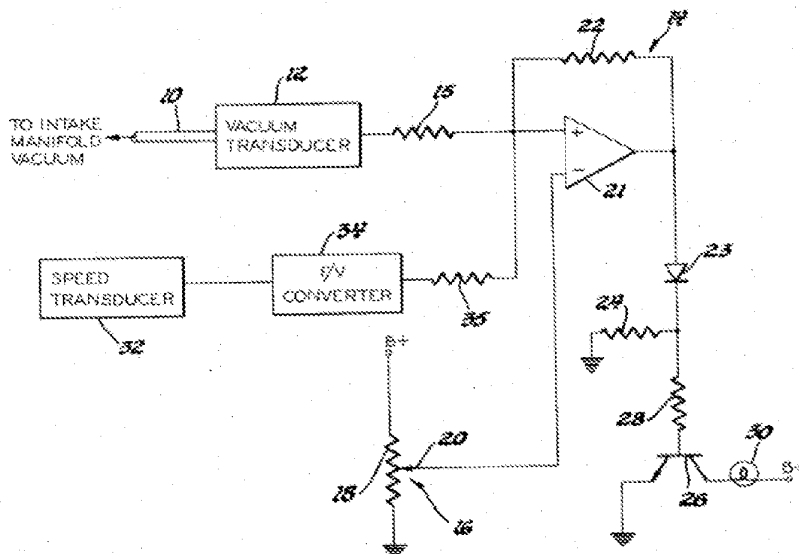

The vacuum transducer 12 of GM '753 “is effective to generate a voltage having a magnitude which progressively changes with a progressively increased manifold intake level.” Col. 1, lines 38 to 55. The speed transducer “generates a series of voltage pulses having a frequency progressively increasing with increasing vehicle speed.” Col. 2, lines 34 to 51. These inputs are fed to an analog circuit acting as a processor, which is used to send current to a lamp when a level “determined to represent excessive fuel consumption” is reached. Col. 2, lines 52 to 58. “When the vehicle is operated in a manner such that the manifold vacuum decreases below the manifold vacuum trigger level established at the instantaneous vehicle speed, *the output of the summing switch 14 swings positive to effect energization of the lamp 30 to provide an indication of fuel consumption in excess of the predetermined amount at that speed.*” Col. 3, lines 20 to 27. Therefore, GM '753 teaches “a fuel overinjection notification circuit coupled to said processor subsystem, said fuel overinjection notification circuit issuing a notification that excessive fuel is being supplied to said engine of said vehicle.” Although GM '753 does not refer to the use of a throttle position sensor, throttle position sensors are taught by Jurgen. Therefore, the combination of



Jurgen and GM '753 teaches "said processor subsystem determining whether to activate said fuel overinjection notification sensor based upon data received from said road speed sensor, said throttle position sensor and said manifold pressure sensor."

Claims 29 and 30 require the fuel overinjection notification circuit to be activated when certain conditions measured by the claimed sensors are either increasing or decreasing. For example, claim 29 requires the fuel overinjection notification circuit to be activated when it is determined that (1) road speed is increasing; (2) throttle position is increasing; and (3) the manifold pressure exceeds a manifold pressure set point. In the remarks that were presented with these claims, the Applicant stated as follows:

Specifically, as presented in new Claims 34-36, Applicants' claimed apparatus for optimizing operation of a vehicle includes a fuel overinjection notification circuit and a processor subsystem which determines when to activate the fuel overinjection notification circuit. The processor makes that determination based upon data received from specifically recited sensors, including the road speed sensor.

February 16, 1999 Amendment, page 11 (emphasis in original).

In allowing these claims, the Examiner stated that the prior art does not disclose that the processor subsystem determines "whether to activate the fuel overinjection notification circuit based upon data received from the road speed sensor, the throttle position sensor and the manifold sensor." April 22, 1999 Notice of Allowability, at 3. The combination of Jurgen and GM '753 teaches the use of road speed, throttle position, and manifold pressure sensors, and also teaches that a fuel overinjection notification circuit can be activated based upon input from these sensors. *See* Jurgen, page 12.22; GM '753, col. 3, lines 20 to 27.

A person of ordinary skill in the art, at the time the alleged inventions of claims 28–30 of the '781 patent were made, would have found it obvious to combine the teachings of Jurgen and GM '753, and, in addition, would have been motivated to do so. Indeed, Jurgen, for example, expressly describes one such motivation: "The motive for using an electronic engine control system is to provide the needed accuracy and adaptability in order to minimize exhaust emissions and fuel consumption, provide optimal driveability for all operating conditions, minimize evaporative emissions, and provide system diagnosis when malfunctions occur." (Jurgen, Page 12.1). A person of ordinary skill in the art, at the time the alleged inventions of claims 28–30 of the '781 patent were made would have been further motivated to combine the teachings of Jurgen and GM '753, to "provide[] the fuel metering and ignition timing precision to minimize fuel consumption (Jurgen, Page 12.4), and to "provide[e] an indication when the fuel consumption of a . . . vehicle . . . exceeds pre-

established levels” (GM ’753, Abstract). The ’781 patent states that its object is to “provide a system which integrates the ability to issue audible warnings which advise the driver to correct operation of the vehicle in a manner which will *enhance the efficient operation* thereof with the ability to automatically take corrective action if the vehicle is being operated unsafely.” Col. 1, line 66 to col. 2, line 5. Thus, like the ’781 patent, Jurgen and GM ’753 are concerned with, for example, improving fuel efficiency.

Furthermore, as additional evidence that a person of ordinary skill in the art would be motivated to combine the teachings of Jurgen and GM ’753, Jurgen describes at page xvii:

Automotive electronics as we know it today encompasses a wide variety of devices and systems. Key to them all, and those yet to come, is the ability to sense and measure accurately automotive parameters. Equally important at the output is the ability to initiate control actions accurately in response to commands. In other words, sensors and actuators are the heart of any automotive electronics application. . . .

The importance of sensors and actuators cannot be overemphasized. The future growth of automotive electronics is arguably more dependent on sufficiently accurate and low-cost sensors and actuators than on computers, controls, displays, and other technologies.

Moreover, the combination of these teachings is merely (a) the combination of prior art elements according to known methods to yield predictable results; (b) the simple substitution of known elements for one another to obtain predictable results; (c) the use of known techniques to improve similar devices in the same way; (d) the application of known techniques to known devices ready for improvement to yield predictable results; (e) obvious to try; and (f) known to work in one field of endeavor prompting variations for use in either the same field or a different one based on design incentives or other market forces since the variations are predictable to one of ordinary skill in the art.

Thus, the combination of Jurgen and GM ’753 teaches the limitations that the applicants asserted were absent from the prior art during prosecution of the ’781 patent, *i.e.*, a fuel overinjection notification circuit that is activated based on three sensors: a road speed sensor, a throttle position sensor, and a manifold pressure sensor. Accordingly, a substantial new question of patentability affecting claims 28–30 is raised by the combination of Jurgen and GM ’753.

As set forth in the appended charts, the combination of Jurgen and GM ’753 teaches all of the limitations of claims 28–30 of the ’781 patent and therefore renders obvious claims

28–30 of the '781 patent. Therefore, VWGoA proposes a ground of rejection of claims 28–30 of the '781 patent under 35 U.S.C. § 103(a) as obvious in view of the combination of Jurgen and GM '753.

**10. Claim 31 is Anticipated Under 35 U.S.C. § 102(b) by Davidian**

Claim 31 is anticipated under 35 U.S.C. § 102(b) by Davidian. Davidian was not cited by the Examiner or the applicants during prosecution of the '781 patent, and Davidian is closer to the subject matter of claim 31 of the '781 patent than any prior art that was relied upon during prosecution of the '781 patent. Davidian provides new, non-cumulative technical teachings that were not otherwise provided in any prior art that was relied upon during prosecution of the '781 patent.

Davidian discloses an anti-collision system that includes “a front space sensor 8 for sensing the space in front of the vehicle, such as the presence of another vehicle.” Col. 4, lines 52 to 66. This front space sensor includes “a transmitter 106 and a receiver 108 for transmitting and receiving the pulses (e.g., RF, ultrasound, laser, IR, etc.) in the front space sensor 8 . . . for measuring the distance of the vehicle from objects in front of . . . the vehicle.” Col. 10, lines 17 to 26. The front space sensor in Davidian continuously transmits pulses (including, in one example, RF pulses) and measures “the round-trip time from the pulse transmission to the echo reception in order to determine the distance of the vehicle from the object.” Col. 10, lines 38 to 50. Therefore, Davidian teaches “a radar detector, said radar detector determining a distance separating a vehicle having an engine and an object in front of said vehicle.”

Davidian also teaches the use of sensors, including “a speed sensor 12 which may sense the speed of the vehicle in any known manner.” Col. 4, lines 60 to 66. Therefore, Davidian teaches “at least one sensor coupled to said vehicle for monitoring operation thereof, said at least one sensor including a road speed sensor.”

Davidian also teaches a processor subsystem, disclosed as microcomputer 4, which is illustrated in FIGS. 6a and 6b. It is coupled to the radar detector (front vehicle space sensor 8) and the vehicle speed sensor 12:

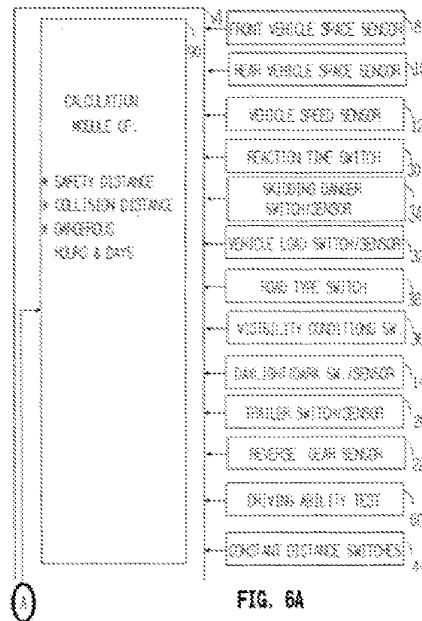

“The microcomputer 4 as illustrated in FIGS. 6a, 6b is divided into various functional modules, as follows: a calculation module 90, which receives data concerning the various parameters briefly described above.” Col. 8, lines 29 to 43. Therefore, Davidian teaches “a processor subsystem, coupled to said radar detector and said at least one sensor, to receive data therefrom.”

Davidian teaches a memory subsystem that stores a vehicle speed/stopping distance table. “*Computer module 90 also includes information about the vehicle braking distances as a function of speed. This is preferably in the form of a look-up table*, for example, provided by the manufacturer for predetermined defined conditions concerning road type, skidding danger, vehicle load and tires pressure, and is *stored in a ROM (read-only memory) of the microcomputer so that it can be changed periodically if necessary.*” Col. 9, lines 20 to 27. This memory subsystem is a part of the microcomputer 4, as illustrated in FIG. 6A. Therefore, Davidian teaches “a memory subsystem, coupled to said processor subsystem, said memory subsystem storing a first vehicle speed/stopping distance table.”

Davidian teaches a vehicle proximity alarm circuit, which activates a collision alarm when a calculated “Collision Distance” is close to a calculated “Stopping Distance.” “A determination is also made of the collision distance CD which is equal to the stopping distance SD divided by the collision safety factor CSF, e.g., 1.25 in the example illustrated above, such that should the distance between the vehicle and the object come within the collision distance CD, the collision alarm is then actuated.” Col. 12, line 59 to col. 13, line

11. The collision alarm, may be an audio alarm or a visual alarm. Col. 9, lines 52 to 56. The determination whether to activate the collision alarm is made by the calculation module 90, which is part of the microcomputer 4. *See* col. 12, line 27 (“Operation of the Calculation Module 90”). Therefore, Davidian teaches “a vehicle proximity alarm circuit coupled to said processor subsystem, said vehicle proximity alarm circuit issuing an alarm that said vehicle is too close to said object.”

Davidian also teaches that the processor subsystem determines when to activate the proximity alarm based on (1) separation distance data (received from the front vehicle space sensor 8); (2) vehicle speed data (received from vehicle speed sensor 12); and (3) the vehicle speed/stopping distance table stored in memory. The radar input, the vehicle speed input, and the vehicle speed/stopping distance tables are all located in the calculation module 90, which it uses to calculate stopping distance and collision distance. Therefore, Davidian teaches “said processor subsystem determining whether to activate said vehicle proximity alarm circuit based upon separation distance data received from said radar detector, vehicle speed data received from said road speed sensor and said first vehicle speed/stopping distance table stored in said memory subsystem.”

Thus, Davidian teaches the limitations that the applicants asserted were absent from the prior art during prosecution of the '781 patent, *i.e.*, a vehicle proximity alarm that is activated based upon three parameters: (1) road speed, as determined by a road speed sensor; (2) separation, as determined by a radar detector; and (3) a vehicle speed/stopping distance table stored in a memory subsystem. Accordingly, a substantial new question of patentability affecting claim 31 is raised by Davidian.

As set forth in the appended charts, Davidian teaches all of the limitations of claim 31 of the '781 patent and therefore anticipates claim 31 of the '781 patent. Therefore, VWGoA proposes a ground of rejection of claim 31 of the '781 patent under 35 U.S.C. § 102(b) as anticipated by Davidian.

**11. Claims 31 and 32 are Obvious Under 35 U.S.C. § 103(a) in View of the Combination of Tonkin and Doi et al.**

Claims 31 and 32 are obvious under 35 U.S.C. § 103(a) in view of the combination of Tonkin and Doi et al. Although Doi et al. was cited by the Examiner during prosecution of the '781 patent, Tonkin was not cited by the Examiner or the applicants during prosecution. Therefore, the question of whether claims 31 and 32 are obvious in view of the combination of Tonkin and Doi et al. was not previously considered. The combination of Tonkin and Doi et al. is closer to the subject matter of claims 31 and 32 of the '781 patent than any prior art

that was relied upon during prosecution of the '781 patent, and the combination of Tonkin and Doi et al. provides new, non-cumulative technical teachings that were not otherwise provided in any prior art that was relied upon during prosecution of the '781 patent.

As more fully explained above, the applicants asserted that claim 31 was allowable over the prior art on the basis that the prior art does not disclose a vehicle proximity alarm that is activated based upon three parameters: (1) road speed, as determined by a road speed sensor; (2) separation, as determined by a radar detector; and (3) a vehicle speed/stopping distance table stored in a memory subsystem. The applicants admitted, however, that a vehicle proximity alarm that is activated based on separation is disclosed in the prior art: "The Applicants respectfully note, however, that the system disclosed in Doi et al. determines alert conditions relative to the proximity between a vehicle and a forward object based upon changes in the distance separating the vehicle and the forward object."

Tonkin discloses a system that calculates a safety envelope and displays a visible warning when a rear-facing vehicle is getting too near. Abstract. Tonkin discloses the use of a radar sensor in order to determine "distance of separation and/or a relative velocity of a trailing vehicle." Page 1, lines 23 to 29. *See also* page 5, lines 4 to 9, "The sensor means for sensing the distance and velocity of the trailing vehicle may comprise a radar system." Therefore, Tonkin discloses "a radar detector."

Tonkin also teaches the use of sensors, including a velocity sensing means comprising "a conventional speed sensing device fitted to the vehicle's transmission train." Page 5, lines 17 to 19. Therefore, Tonkin teaches "at least one sensor coupled to said vehicle for monitoring operation thereof, said at least one sensor including a road speed sensor."

Tonkin also teaches the use of a processor coupled to the sensor. Page 1, lines 32 to 34 ("wherein the controller is operable to process the received velocity signal and data signals to determine the existence of an unsafe condition"). Therefore, Tonkin discloses "a processor subsystem, coupled to said radar detector and said at least one sensor, to receive data therefrom."

Tonkin teaches the use of a memory subsystem that stores parameters in a lookup table, including a vehicle speed/stopping distance table. For example, Tonkin teaches that predetermined driving parameters "may for example be stored in a look up table." Page 3, lines 25 to 32. Additionally, the control system that activates the vehicle proximity alarm relies in part on "known safe stopping distances such as those published by the Minister of Transport, in which a vehicle will stop when the brakes are applied." Page 16, lines 2 to 21. Finally, Tonkin teaches that a look-up table or database could be provided for unsafe closing

speeds, which could be varied according to the velocity of the subject vehicle.” Page 17, lines 7 to 25. Therefore, Tonkin teaches “a memory subsystem, coupled to said processor subsystem, said memory subsystem storing a first vehicle speed/stopping distance table.”

Tonkin also teaches a vehicle proximity alarm circuit. “***The system may comprise means for warning*** that the subject vehicle is stationary. ***The system can further comprise means for providing warning*** of different levels of deceleration of the subject vehicle. ***The warning means can comprise an orange light display for the relative speed and/or relative separation conditions and a red light display for the vehicle stationary and/or levels of deceleration conditions.*** The relative separation and/or relative speed warning may be overridden by the level of deceleration warning.” Page 2, line 29 to page 3, line 3. The control system in Tonkin warns the driver behind the vehicle equipped with the device that the driver is getting too close. Therefore, Tonkin teaches “a vehicle proximity alarm circuit coupled to said processor subsystem, said vehicle proximity alarm circuit issuing an alarm that said vehicle is too close to said object.”

Tonkin teaches that the processor subsystem determines when to activate the proximity alarm circuit based upon (1) separation distance data received from said radar detector; (2) vehicle speed data received from said road speed sensor; and (3) the vehicle speed/stopping distance table. For example, the radar system is “operable to sense a distance of separation and/or a relative velocity of a trailing vehicle.” Page 1, lines 32 to 34. The processor subsystem “is operable to process the received velocity signal and data signals to determine the existence of an unsafe condition.” The velocity signal used by the processing means is the vehicle velocity signal determined from the vehicle speed sensor. Page 5, lines 17 to 19. The data signals include the separation data (determined from the radar), and the determination regarding whether to activate the alarm is made, in part, using the safe stopping distances provided in the look-up table. Page 17, lines 7 to 25. Therefore, Tonkin teaches “said processor subsystem determining whether to activate said vehicle proximity alarm circuit based upon separation distance data received from said radar detector, vehicle speed data received from said road speed sensor and said first vehicle speed/stopping distance table stored in said memory subsystem.”

Although Tonkin does not refer to the radar detector determining a distance separating a vehicle having an engine and an object *in front* of the vehicle, Doi et al., which was cited by the Examiner during prosecution of the '781 patent, discloses a radar detector that “emits a pulse laser beam (as a radar wave) forward of the vehicle 1 from the source and receives reflected light beam reflected by a forward object in the way such as a vehicle, thereby

measuring the distance from the vehicle 1 to the forward object.” Col. 2, lines 59 to 62. Therefore, Doi et al. teaches “a radar detector, said radar detector determining a distance separating a vehicle having an engine and an object in front of said vehicle.”

Tonkin teaches that “information regarding the weather might be obtained for example by enabling the warning system controller to ascertain if the windscreen wipers are in use or have been in use recently due to rain.” Page 18, lines 9 to 13. Additionally, Tonkin teaches that “safe stopping distances can be adjusted for prevailing weather conditions.” Page 18, lines 16 to 19. Therefore, Tonkin discloses the adjustment of the vehicle speed/stopping distance tables based upon weather information determined from a windshield wiper sensor as claimed in claim 32.

A person of ordinary skill in the art, at the time the alleged invention of claims 31 and 32 of the '781 patent was made, would have found it obvious to combine the teachings of Tonkin and Doi et al., and, in addition, would have been motivated to do so, for example, to “provide safety information for example to drivers of following vehicles” (Tonkin, page 1, lines 4-5) and to “detect the relative speed of a vehicle to a forward object (e.g., a forward vehicle) at high efficiency” (Doi et al., col. 1, lines 34 to 36). The '781 patent states that its object is to “provide a system which integrates the ability to issue audible warnings which advise the driver to correct operation of the vehicle in a manner which will enhance the efficient operation thereof with the ability to automatically take corrective action if the vehicle is being operated unsafely.” Col. 1, line 66 to col. 2, line 5. Thus, like the '781 patent, Tonkin and Doi et al. are concerned with, for example, vehicle safety.

Moreover, the combination of these teachings is merely (a) the combination of prior art elements according to known methods to yield predictable results; (b) the simple substitution of known elements for one another to obtain predictable results; (c) the use of known techniques to improve similar devices in the same way; (d) the application of known techniques to known devices ready for improvement to yield predictable results; (e) obvious to try; and (f) known to work in one field of endeavor prompting variations for use in either the same field or a different one based on design incentives or other market forces since the variations are predictable to one of ordinary skill in the art.

Thus, the combination of Tonkin and Doi et al. teaches the limitations that the applicants asserted were absent from the prior art during prosecution of the '781 patent, *i.e.*, disclose a vehicle proximity alarm that is activated based upon three parameters: (1) road speed, as determined by a road speed sensor; (2) separation, as determined by a radar detector; and (3) a vehicle speed/stopping distance table stored in a memory subsystem.



Accordingly, a substantial new question of patentability affecting claims 31 and 32 is raised by the combination of Tonkin and Doi et al.

As set forth in the appended charts, the combination of Tonkin and Doi et al. teaches all of the limitations of claims 31 and 32 of the '781 patent and therefore renders obvious claims 31 and 32 of the '781 patent. Therefore, VWGoA proposes a ground of rejection of claims 31 and 32 of the '781 patent under 35 U.S.C. § 103(a) as obvious in view of the combination of Tonkin and Doi et al.

**12. Claims 2, 4, and 5 are Obvious Under 35 U.S.C. § 103(a) in View of the Combination of Jurgen, Saturn '452, and Chasteen**

Claims 2, 4, and 5 are obvious under 35 U.S.C. § 103(a) in view of the combination of Jurgen, Saturn '452, and Chasteen. Although Chasteen was cited by the Examiner during prosecution of the '781 patent, neither Jurgen nor Saturn '452 was cited by the Examiner or the applicants during prosecution. Therefore, the question of whether claims 2, 4, and 5 are obvious in view of the combination of Jurgen, Saturn '452, and Chasteen was not previously considered. The combination of Jurgen, Saturn '452, and Chasteen is closer to the subject matter of claims 2, 4, and 5 of the '781 patent than any prior art that was relied upon during prosecution of the '781 patent. The combination of Jurgen, Saturn '452, and Chasteen provides new, non-cumulative technical teachings that were not otherwise provided in any prior art that was relied upon during prosecution of the '781 patent.

As more fully explained above, the Examiner concluded that claim 1, from which claims 2, 4, and 5 depend, was allowable over the prior art cited during prosecution on the basis that the prior art does not teach an upshift notification circuit, wherein the processor determines, based upon data received from sensors, when to activate said upshift notification circuit, and there is no indication in the prosecution history that any of dependent claims 2, 4, and 5 were allowable over the cited prior art for any reason other than their dependency from claim 1. As also more fully explained above, the combination of Jurgen and Saturn '452 raises a substantial new question of patentability affecting claim 1 and renders obvious claim 1 under 35 U.S.C. § 103(a).

During prosecution of the '781 patent, the Examiner determined that a person of ordinary skill in the art would have found the added limitations of dependent claims 2, 4, and

5 obvious in view of the teachings of Chasteen.<sup>10</sup> For example, in rejecting claims 2 and 4 as obvious in view of Chasteen, the Examiner found that:

Chasteen discloses the sensors as discussed for sensing the signals and a processor and compare [sic] manifold pressure for activating the fuel injection. Chasteen discloses the speed (RPM) and throttle position are determined to be greater than 0 (increasing) and the CPU provide s control command to the engine to prime the engine (See column 11, lines 22-33) therefore on [sic] would consider increasing and decreasing the speed and throttle for adjusting the fuel injector for supplying fuel to the engine.

In the amendment filed by the applicants in response to the Office Action containing the foregoing findings, the applicants did not amend claims 2 and 4 and did not present any arguments against the Examiner's findings. Instead, and as indicated above, the applicants amended claim 1, from which claims 2, 4 , and 5 depend, to include the upshift notification circuit limitations that the Examiner found missing from the prior art.

Jurgen discloses an electronic engine control system that receives sensor inputs, evaluates them, and determines the necessary outputs to provide for optimal driveability. (Jurgen, page 12.1). Jurgen also discloses that these sensors monitor engine speed (page 7.6), road speed (pages 7.8, 14.3), manifold pressure (pages 2.5, 2.7), throttle position (page 12.21). Jurgen also teaches that the use of processor subsystems to receive inputs from these sensors was known. (Pages 12.1, 13.6, 22.6). "During the entire operating time of the vehicle, the ECUs are constantly supervising the sensors they are connected to." (Page 22.6). Indeed, Jurgen discloses a diagram of these hardware parts:

---

<sup>10</sup> To render a claim obvious, "[t]he prior art reference (or references when combined) need not teach or suggest all of the claim limitations." M.P.E.P. § 2141

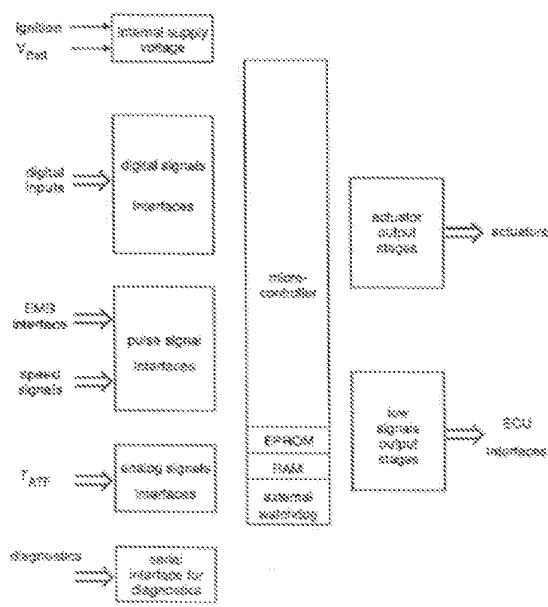

FIGURE 22.2 Overview of hardware parts.

Jurgen, therefore, teaches “means for determining when road speed for said vehicle is increasing[/decreasing],” means for determining when throttle position for said vehicle is increasing[/decreasing],” and “means for determining when throttle position for said vehicle is increasing[/decreasing]” as claimed in claims 2, 4, and 5.

Jurgen teaches a fuel overinjection notification circuit, which issues a notification that excessive fuel is being supplied to the engine of the vehicle. For example, the ECU taught by Jurgen can shut off fuel in certain situations by evaluating the throttle position, engine RPM, and vehicle speed. (Page 12.4). Additionally, the ECU can shut off fuel injectors when a maximum speed is achieved (page 12.14). The ECU provides the fuel overinjection notification to the fuel injectors when a fuel cutoff state is reached. For example, the combination of the ECU, which monitors all of the vehicle’s sensors (see above) and the TCU, which stores the shift maps, can send notification circuits to the fuel injectors and/or the transmission in order to alleviate a fuel overinjection condition.

Because Saturn ’452 discloses an upshift notification circuit triggered by a processor in response to sensors (*see* col. 2, lines 42 to 55), the Examiner’s statements that the fuel overinjection circuit triggered based upon sensor inputs would have been obvious in view of Chasteen also apply to the upshift notification circuit in view of Saturn ’452.

A person of ordinary skill in the art, at the time the alleged inventions of claims 2, 4, and 5 of the ’781 patent were made, would have found it obvious to combine the teachings of Jurgen, Saturn ’452, and Chasteen, and, in addition, would have been motivated to do so.

Indeed, Jorgen, for example, expressly describes one such motivation: “The motive for using an electronic engine control system is to provide the needed accuracy and adaptability in order to minimize exhaust emissions and fuel consumption, provide optimal driveability for all operating conditions, minimize evaporative emissions, and provide system diagnosis when malfunctions occur.” (Jorgen, Page 12.1). A person of ordinary skill in the art, at the time the alleged inventions of claims 2, 4, and 5 of the ’781 patent were made would have been further motivated to combine the teachings of Jorgen, Saturn ’452, and Chasteen, to “provide optimal driveability for all operating conditions” (Jorgen, Page 12.1), to “provide[] the fuel metering and ignition timing precision to minimize fuel consumption (Jorgen, Page 12.4), to provide a “means for indicating to the operator a point in operation for upshifting to the next higher gear” (Saturn ’452, Abstract), to provide “an improved method of determining shift points and indicating the same to a vehicle operator in order to maximize real driving fuel economy” (Saturn ’452, col. 1, lines 44 to 47), and to indicate the “optimum fuel requirements for the engine” (Chasteen, col. 2, lines 48 to 54). The ’781 patent states that its object is to “provide a system which integrates the ability to issue audible warnings which advise the driver to correct operation of the vehicle in a manner which will *enhance the efficient operation* thereof with the ability to automatically take corrective action if the vehicle is being operated unsafely.” Col. 1, line 66 to col. 2, line 5. Thus, like the ’781 patent, Jorgen, Saturn ’452, and Chasteen are concerned with, for example, improving fuel efficiency.

Furthermore, as additional evidence that a person of ordinary skill in the art would be motivated to combine the teachings of Jorgen, Saturn ’452, and Chasteen, Jorgen describes at page xvii:

Automotive electronics as we know it today encompasses a wide variety of devices and systems. Key to them all, and those yet to come, is the ability to sense and measure accurately automotive parameters. Equally important at the output is the ability to initiate control actions accurately in response to commands. In other words, sensors and actuators are the heart of any automotive electronics application. . . .

The importance of sensors and actuators cannot be overemphasized. The future growth of automotive electronics is arguably more dependent on sufficiently accurate and low-cost sensors and actuators than on computers, controls, displays, and other technologies.

Moreover, the combination of these teachings is merely (a) the combination of prior art elements according to known methods to yield predictable results; (b) the simple substitution of known elements for one another to obtain predictable results; (c) the use of known techniques to improve similar devices in the same way; (d) the application of known techniques to known devices ready for improvement to yield predictable results; (e) obvious to try; and (f) known to work in one field of endeavor prompting variations for use in either the same field or a different one based on design incentives or other market forces since the variations are predictable to one of ordinary skill in the art.

As set forth in the appended charts, the combination of Jurgén, Saturn '452, and Chasteen teaches all of the limitations of claims 2, 4, and 5 of the '781 patent and therefore renders obvious claims 2, 4, and 5 of the '781 patent. Therefore, VWGoA proposes a ground of rejection of claims 2, 4, and 5 of the '781 patent under 35 U.S.C. § 103(a) as obvious in view of the combination of Jurgén, Saturn '452, and Chasteen.

**13. Claims 2, 4, 5, 8, 10, 12, and 15 are Obvious Under 35 U.S.C. § 103(a) in View of the Combination of Jurgén, Toyota '599, and Chasteen**

Claims 2, 4, 5, 8, 10, 12, and 15 are obvious under 35 U.S.C. § 103(a) in view of the combination of Jurgén, Toyota '599, and Chasteen. While Chasteen was cited by the Examiner during prosecution, neither Jurgén nor Toyota '599 was cited by the Examiner or the applicants during prosecution. Thus, the question of whether claims 2, 4, 5, 8, 10, 12, and 15 are obvious in view of the combination of Jurgén, Toyota '599, and Chasteen was not previously considered. The combination of Jurgén, Toyota '599, and Chasteen is closer to the subject matter of claims 2, 4, 5, 8, 10, 12, and 15 of the '781 patent than any prior art that was relied upon during prosecution of the '781 patent. The combination of Jurgén, Toyota '599, and Chasteen provides new, non-cumulative technical teachings that were not otherwise provided in any prior art that was relied upon during prosecution of the '781 patent.

As more fully explained above, the Examiner concluded that claims 1, 7, and 13, from which claims 2, 4, 5, 8, 10, 12, and 15 depend, were allowable over the prior art cited during prosecution solely on the basis that the prior art does not teach upshift and/or downshift notification circuits, wherein the processor determines, based upon data received from sensors, when to activate said upshift and/or downshift notification circuits, and there is no indication in the prosecution history that any of dependent claims 2, 4, 5, 8, 10, 12, and 15 were considered allowable over the cited prior art for any reason other than their dependency from claim 1, 7, or 13.

As set forth in more detail above, the combination of Jurgen and Toyota '599 raises a substantial new question of patentability affecting claims 1, 7, and 13 and renders unpatentable claims 1, 7, and 13 under 35 U.S.C. § 103(a).

During prosecution of the '781 patent, the Examiner determined that a person of ordinary skill in the art would have found the added limitations of dependent claims 2, 4, 5, 8, 10, 12, and 15 obvious in view of the teachings of Chasteen.<sup>11</sup> For example, in rejecting claims 2, 4, and 8 as obvious in view of Chasteen, the Examiner found that:

Chasteen discloses the sensors as discussed for sensing the signals and a processor and compare [sic] manifold pressure for activating the fuel injection. Chasteen discloses the speed (RPM) and throttle position are determined to be greater than 0 (increasing) and the CPU provides a control command to the engine fuel injector to prime the engine (See column 11, lines 22-33) therefore on [sic] would consider increasing and decreasing the speed and throttle for adjusting the fuel injector for supplying fuel to the engine.

In the Amendment filed by the applicants in response to the Office Action containing the foregoing findings, the applicants did not amend claims 2, 4, or 8 and did not present any arguments against the Examiner's findings. Instead, and as indicate above, the applicants amended claim 1, from which claims 2, 4, and 5 depend, to include the upshift notification circuit limitations that the Examiner found missing from the prior art. Similarly, the applicants rewrote claim 7, from which claims 8, 10, 12 depend, into independent form, in effect adding the downshift notification circuit limitations that the Examiner found missing from the prior art.<sup>12</sup> As for claim 15, which depends from claim 13, the Examiner allowed claim 13, and dependent claim 15, because claim 13 include the upshift and downshift notification circuit limitations that the Examiner found missing from the prior art.

Jurgen teaches an electronic engine control system that receives sensor inputs, evaluates them, and determines the necessary outputs to provide for optimal driveability. (Jurgen, page 12.1). Jurgen also teaches that these sensors monitor engine speed (page 7.6), road speed (pages 7.8, 14.3), manifold pressure (pages 2.5, 2.7), throttle position (page 12.21), and acceleration, *i.e.*, change in speed, (pages 7.8 to 7.18), and that the use of

---

<sup>11</sup> To render a claim obvious, “[t]he prior art reference (or references when combined) need not teach or suggest all of the claim limitations.” M.P.E.P. § 2141.

<sup>12</sup> See, e.g., *Honeywell Int'l v. Hamilton Sundstrand Corp.*, 370 F.3d 1131, 1144 (Fed. Cir. 2004) (“[D]ependent c]laims 4, 8, and 19 were rewritten into independent form, and the original independent claims were cancelled, effectively adding the inlet guide vane limitations [of dependent claims 4, 8 and 19] to the claimed invention.”).

processor subsystems to receive inputs from these sensors was known. (Pages 12.1, 13.6, 22.6) “During the entire operating time of the vehicle, the ECUs are constantly supervising the sensors they are connected to.” (Page 22.6). Indeed, Jurgen discloses a diagram of these hardware parts:

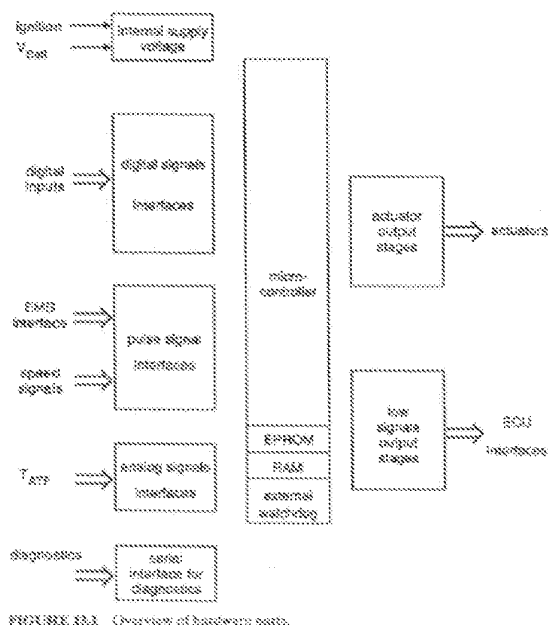

Jurgen, therefore, teaches “means for determining when road speed for said vehicle is increasing[/decreasing],” means for determining when throttle position for said vehicle is increasing[/decreasing],” and “means for determining when throttle position for said vehicle is increasing[/decreasing]” as claimed in claims 2, 4, 5, 8, 10, 12, and 15.

Jurgen teaches a fuel overinjection notification circuit, which issues a notification that excessive fuel is being supplied to the engine of the vehicle. For example, the ECU taught by Jurgen can shut off fuel in certain situations by evaluating the throttle position, engine RPM, and vehicle speed. (Page 12.4). Additionally, the ECU can shut off fuel injectors when a maximum speed is achieved (page 12.14). The ECU provides the fuel overinjection notification to the fuel injectors when a fuel cutoff state is reached. Based upon the Examiner’s findings during the original prosecution, it would have been obvious to one of ordinary skill in the art to enable the fuel overinjection notification circuit based upon sensor inputs. For example, the combination of the ECU, which monitors all of the vehicle’s sensors (see above) and the TCU, which stores the shift maps, can send notification circuits to the fuel injectors and/or the transmission in order to alleviate a fuel overinjection condition.

Claims 5, 10, and 15 require that the upshift and/or downshift notification circuits are activated based upon the same types of sensor inputs. For example, claim 5 requires that “said processor subsystem activating said upshift notification circuit if both road speed and throttle position for said vehicle are increasing, manifold pressure for said vehicle is at or below said manifold pressure set point and engine speed for said vehicle is at or above said RPM set point.” These claims were indicated as allowable because “the prior art fails to disclose an upshift notification circuit coupled to the processor subsystem, the upshift notification circuit issuing a notification that the engine of the vehicle is being operated at an excessive engine speed and the processor determines when to activate the upshift notification circuit and a downshift notification circuit coupled to the processor subsystem, the downshift notification circuit issuing a notification that the engine of the vehicle is being operated at an insufficient engine speed and the processor determines when to activate the downshift notification circuit.”<sup>13</sup> Because Toyota ’599 discloses both upshift and downshift notification circuits triggered by a processor in response to sensors (*see* col. 5, line 63 to col. 6, line 2), the Examiner’s statements that the fuel overinjection circuit triggered based upon sensor inputs would have been obvious in view of Chasteen also apply to the upshift/downshift notification circuits in view of Toyota ’599.

A person of ordinary skill in the art, at the time the alleged inventions of claims 2, 4, 5, 8, 10, 12, and 15 of the ’781 patent were made, would have found it obvious to combine the teachings of Jurgen, Toyota ’599, and Chasteen, and, in addition, would have been motivated to do so. Indeed, Jurgen, for example, expressly describes one such motivation: “The motive for using an electronic engine control system is to provide the needed accuracy and adaptability in order to minimize exhaust emissions and fuel consumption, provide optimal driveability for all operating conditions, minimize evaporative emissions, and provide system diagnosis when malfunctions occur.” (Jurgen, Page 12.1). A person of ordinary skill in the art, at the time the alleged inventions of claims 2, 4, 5, 8, 10, 12, and 15 of the ’781 patent were made would have been further motivated to combine the teachings of Jurgen, Toyota ’599, and Chasteen, to “provide optimal driveability for all operating conditions” (Jurgen, Page 12.1), to “provide[] the fuel metering and ignition timing precision to minimize fuel consumption (Jurgen, Page 12.4), to “obtain preferable shift positions relating to optimum fuel consumption rate in accordance with . . . data detected” (Toyota

---

<sup>13</sup> Claim 15 was explicitly allowed for the quoted reason. Claims 5 and 10 were objected to as being dependent on a rejected base claim, and were allowed when the upshift/downshift notification circuit limitations were added to the independent claims.



'599, Abstract), and to indicate the “optimum fuel requirements for the engine” (Chasteen, col. 2, lines 48 to 54). The '781 patent states that its object is to “provide a system which integrates the ability to issue audible warnings which advise the driver to correct operation of the vehicle in a manner which will *enhance the efficient operation* thereof with the ability to automatically take corrective action if the vehicle is being operated unsafely.” Col. 1, line 66 to col. 2, line 5. Thus, like the '781 patent, Jurgén, Toyota '599, and Chasteen are concerned with, for example, improving fuel efficiency.

Furthermore, as additional evidence that a person of ordinary skill in the art would be motivated to combine the teachings of Jurgén, Toyota '599, and Chasteen, Jurgén describes at page xvii:

Automotive electronics as we know it today encompasses a wide variety of devices and systems. Key to them all, and those yet to come, is the ability to sense and measure accurately automotive parameters. Equally important at the output is the ability to initiate control actions accurately in response to commands. In other words, sensors and actuators are the heart of any automotive electronics application. . . .

The importance of sensors and actuators cannot be overemphasized. The future growth of automotive electronics is arguably more dependent on sufficiently accurate and low-cost sensors and actuators than on computers, controls, displays, and other technologies.

Moreover, the combination of these teachings is merely (a) the combination of prior art elements according to known methods to yield predictable results; (b) the simple substitution of known elements for one another to obtain predictable results; (c) the use of known techniques to improve similar devices in the same way; (d) the application of known techniques to known devices ready for improvement to yield predictable results; (e) obvious to try; and (f) known to work in one field of endeavor prompting variations for use in either the same field or a different one based on design incentives or other market forces since the variations are predictable to one of ordinary skill in the art.

As set forth in the appended charts, the combination of Jurgén, Toyota '599, and Chasteen teaches all of the limitations of claims 2, 4, 5, 8, 10, 12, and 15 of the '781 patent and therefore renders obvious claims 2, 4, 5, 8, 10, 12, and 15 of the '781 patent. Therefore, VWGoA proposes a ground of rejection of claims 2, 4, 5, 8, 10, 12, and 15 of the '781 patent under 35 U.S.C. § 103(a) as obvious in view of the combination of Jurgén, Toyota '599, and Chasteen.

**14. Claims 2, 4, 5, 8, 10, 12, and 15 are Obvious Under 35 U.S.C. § 103(a) in View of the Combination of Jurgen, Volkswagen '070, and Chasteen**

Claims 2, 4, 5, 8, 10, 12, and 15 are obvious under 35 U.S.C. § 103(a) in view of the combination of Jurgen, Volkswagen '070, and Chasteen. Although Chasteen was cited during prosecution of the '781 patent, neither Jurgen nor Volkswagen '070 was cited by the Examiner or the applicants during prosecution. Thus, the question of whether claims 2, 4, 5, 8, 10, 12, and 15 are obvious in view of the combination of Jurgen, Volkswagen '070, and Chasteen was not previously considered. The combination of Jurgen, Volkswagen '070, and Chasteen is closer to the subject matter of claims 2, 4, 5, 8, 10, 12, and 15 of the '781 patent than any prior art that was relied upon during prosecution of the '781 patent. The combination of Jurgen, Volkswagen '070, and Chasteen provides new, non-cumulative technical teachings that were not otherwise provided in any prior art that was relied upon during prosecution of the '781 patent.

As more fully explained above, the Examiner concluded that claims 1, 7, and 13, from which claims 2, 4, 5, 8, 10, 12, and 15 depend, were allowable over the prior art cited during prosecution on the basis that the prior art does not teach upshift and/or downshift notification circuits, wherein the processor determines, based upon data received from sensors, when to activate said upshift and/or downshift notification circuits, and there is no indication in the prosecution history that any of dependent claims 2, 4, 5, 8, 10, 12, and 15 were considered allowable over the prior art for any reason other than their dependency from claim 1, 7, or 13.

As set forth in more detail above, the combination of Jurgen and Volkswagen '070 raises a substantial new question of patentability affecting claims 1, 7, and 13 and renders obvious claims 1, 7, and 13 under 35 U.S.C. § 103(a).

During prosecution of the '781 patent, the Examiner determined that a person of ordinary skill in the art would have found the added limitations of dependent claims 2, 4, 5, 8, 10, 12, and 15 obvious in view of the teachings of Chasteen.<sup>14</sup> For example, in rejecting claims 2, 4, and 8 as obvious in view of Chasteen, the Examiner found that:

Chasteen discloses the sensors as discussed for sensing the signals and a processor and compare [sic] manifold pressure for activating the fuel injection. Chasteen discloses the speed (RPM) and throttle position are determined to be greater than 0 (increasing) and the CPU provides a control command to the

---

<sup>14</sup> To render a claim obvious, “[t]he prior art reference (or references when combined) need not teach or suggest all of the claim limitations.” M.P.E.P. § 2141.

engine fuel injector to prime the engine (See column 11, lines 22-33) therefore on [sic] would consider increasing and decreasing the speed and throttle for adjusting the fuel injector for supplying fuel to the engine.

In the Amendment filed by the applicants in response to the Office Action containing the foregoing findings, the applicants did not amend claims 2, 4, or 8 and did not present any arguments against the Examiner's findings. Instead, and as indicate above, the applicants amended claim 1, from which claims 2, 4, and 5 depend, to include the upshift notification circuit limitations that the Examiner found missing from the prior art. Similarly, the applicants rewrote claim 7, from which claims 8, 10, 12 depend, into independent form, in effect adding the downshift notification circuit limitations that the Examiner found missing from the prior art.<sup>15</sup> As for claim 15, which depends from claim 13, the Examiner allowed claim 13, and dependent claim 15, because claim 13 include the upshift and downshift notification circuit limitations that the Examiner found missing from the prior art.

Jurgen teaches an electronic engine control system that receives sensor inputs, evaluates them, and determines the necessary outputs to provide for optimal driveability. (Jurgen, page 12.1). Jurgen also teaches that these sensors monitor engine speed (page 7.6), road speed (pages 7.8, 14.3), manifold pressure (pages 2.5, 2.7), throttle position (page 12.21), and acceleration, *i.e.*, change in speed, (pages 7.8 to 7.18), and that the use of processor subsystems to receive inputs from these sensors was known. (Pages 12.1, 13.6, 22.6). "During the entire operating time of the vehicle, the ECUs are constantly supervising the sensors they are connected to." (Page 22.6). Indeed, Jurgen discloses a diagram of these hardware parts:

---

<sup>15</sup> See, e.g., *Honeywell Int'l v. Hamilton Sundstrand Corp.*, 370 F.3d 1131, 1144 (Fed. Cir. 2004) ("[D]ependent c]laims 4, 8, and 19 were rewritten into independent form, and the original independent claims were cancelled, effectively adding the inlet guide vane limitations [of dependent claims 4, 8 and 19] to the claimed invention.").

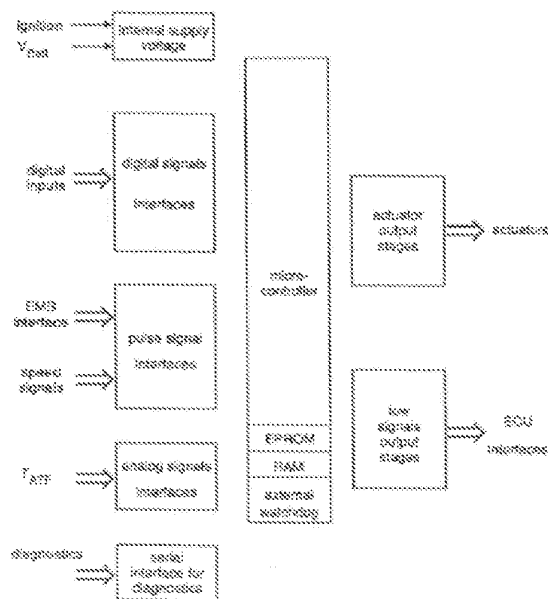

FIGURE 23.3 Overview of hardware parts.

Jurgen, therefore, teaches “means for determining when road speed for said vehicle is increasing[/decreasing],” means for determining when throttle position for said vehicle is increasing[/decreasing],” and “means for determining when throttle position for said vehicle is increasing[/decreasing]” as claimed in claims 2, 4, 5, 8, 10, 12, and 15.

Volkswagen '070 acknowledges that automobile instrument panels that display fuel economy are in the prior art. For example, Volkswagen '070 describes at page 9:

It is useful in addition to this device, a display of the route-specific fuel consumption is provided in a vehicle. Such display devices are known per se; they generally utilize the *induction manifold vacuum* as a measure of the fuel consumption. . . . In this case it is useful to integrate the signal transmitters denoted by 4 and 5 in Figure 2 into the instrument of the fuel consumption display, as sketched in Figure 3. During standard driving operation, pointer 30 of the fuel consumption display sweeps scale 31, while it is hidden behind cover 32 during an idling operation or at full-load accelerations. Incorporated in the scale is arrow 33, which constitutes part of a signal transmitter requesting upshifting, which therefore corresponds to signal transmitter 4 in Figure 2.

(emphasis added)

Thus, by describing a fuel consumption display that indicates full-load acceleration, Volkswagen '070 teaches “means for determining when road speed for said vehicle is increasing[/decreasing],” means for determining when throttle position for said vehicle is

increasing[/decreasing],” “means for determining when throttle position for said vehicle is increasing[/decreasing],” and the processor activating the fuel overinjection circuit based upon measurements from these sensors as claimed in claims 2, 4, 5, 8, 10, 12, and 15.

Jurgen teaches a fuel overinjection notification circuit, which issues a notification that excessive fuel is being supplied to the engine of the vehicle. For example, the ECU taught by Jurgen can shut off fuel in certain situations by evaluating the throttle position, engine RPM, and vehicle speed. (Page 12.4). Additionally, the ECU can shut off fuel injectors when a maximum speed is achieved (page 12.14). The ECU provides the fuel overinjection notification to the fuel injectors when a fuel cutoff state is reached. Based upon the Examiner’s findings during the original prosecution, it would have been obvious to one of ordinary skill in the art to enable the fuel overinjection notification circuit based upon sensor inputs. For example, the combination of the ECU, which monitors all of the vehicle’s sensors (see above) and the TCU, which stores the shift maps, can send notification circuits to the fuel injectors and/or the transmission in order to alleviate a fuel overinjection condition.

Claims 5, 10, and 15 require that the upshift and/or downshift notification circuits are activated based upon the same types of sensor inputs. For example, claim 5 requires that “said processor subsystem activating said upshift notification circuit if both road speed and throttle position for said vehicle are increasing, manifold pressure for said vehicle is at or below said manifold pressure set point and engine speed for said vehicle is at or above said RPM set point.” These claims were indicated as allowable because “the prior art fails to disclose an upshift notification circuit coupled to the processor subsystem, the upshift notification circuit issuing a notification that the engine of the vehicle is being operated at an excessive engine speed and the processor determines when to activate the upshift notification circuit and a downshift notification circuit coupled to the processor subsystem, the downshift notification circuit issuing a notification that the engine of the vehicle is being operated at an insufficient engine speed and the processor determines when to activate the downshift notification circuit.”<sup>16</sup> Because Volkswagen ’070 discloses both upshift and downshift notification circuits triggered by a processor in response to sensors (*see* pages 6–8), the Examiner’s statements that the fuel overinjection circuit triggered based upon sensor inputs would have been obvious in view of Chasteen also apply to the upshift/downshift notification circuits in view of Volkswagen ’070.

---

<sup>16</sup> Claim 15 was explicitly allowed for the quoted reason. Claims 5 and 10 were objected to as being dependent on a rejected base claim, and were allowed when the upshift/downshift notification circuit limitations were added to the independent claims.

A person of ordinary skill in the art, at the time the alleged inventions of claims 2, 4, 5, 8, 10, 12, and 15 of the '781 patent were made, would have found it obvious to combine the teachings of Jurgen, Volkswagen '070, and Chasteen, and, in addition, would have been motivated to do so. Indeed, Jurgen, for example, expressly describes one such motivation: "The motive for using an electronic engine control system is to provide the needed accuracy and adaptability in order to minimize exhaust emissions and fuel consumption, provide optimal driveability for all operating conditions, minimize evaporative emissions, and provide system diagnosis when malfunctions occur." (Jurgen, Page 12.1). A person of ordinary skill in the art, at the time the alleged inventions of claims 2, 4, 5, 8, 10, 12, and 15 of the '781 patent were made would have been further motivated to combine the teachings of Jurgen, Volkswagen '070, and Chasteen, to "provide optimal driveability for all operating conditions" (Jurgen, Page 12.1), , to "provide[] the fuel metering and ignition timing precision to minimize fuel consumption (Jurgen, Page 12.4), to "provid[e] a device that assists the operator of the internal combustion engine equipped with a conventional transmission . . . for example, in setting an operating point of the engine that is advantageous in terms of fuel consumption" (Volkswagen '070, page 5)and to indicate the "optimum fuel requirements for the engine" (Chasteen, col. 2, lines 48 to 54). The '781 patent states that its object is to "provide a system which integrates the ability to issue audible warnings which advise the driver to correct operation of the vehicle in a manner which will *enhance the efficient operation* thereof with the ability to automatically take corrective action if the vehicle is being operated unsafely." Col. 1, line 66 to col. 2, line 5. Thus, like the '781 patent, Jurgen, Volkswagen '070, and Chasteen are concerned with, for example, improving fuel efficiency.

Furthermore, as additional evidence that a person of ordinary skill in the art would be motivated to combine the teachings of Jurgen, Volkswagen '070, and Chasteen, Jurgen describes at page xvii:

Automotive electronics as we know it today encompasses a wide variety of devices and systems. Key to them all, and those yet to come, is the ability to sense and measure accurately automotive parameters. Equally important at the output is the ability to initiate control actions accurately in response to commands. In other words, sensors and actuators are the heart of any automotive electronics application. . . .

The importance of sensors and actuators cannot be overemphasized. The future growth of automotive electronics is arguably more dependent on sufficiently accurate and low-

cost sensors and actuators than on computers, controls, displays, and other technologies.

Moreover, the combination of these teachings is merely (a) the combination of prior art elements according to known methods to yield predictable results; (b) the simple substitution of known elements for one another to obtain predictable results; (c) the use of known techniques to improve similar devices in the same way; (d) the application of known techniques to known devices ready for improvement to yield predictable results; (e) obvious to try; and (f) known to work in one field of endeavor prompting variations for use in either the same field or a different one based on design incentives or other market forces since the variations are predictable to one of ordinary skill in the art.

As set forth in the appended charts, the combination of Jurgen, Volkswagen '070, and Chasteen teaches all of the limitations of claims 2, 4, 5, 8, 10, 12, and 15 of the '781 patent and therefore renders obvious claims 2, 4, 5, 8, 10, 12, and 15 of the '781 patent. Therefore, VWGoA proposes a ground of rejection of claims 2, 4, 5, 8, 10, 12, and 15 of the '781 patent under 35 U.S.C. § 103(a) as obvious in view of the combination of Jurgen, Volkswagen '070, and Chasteen.

**15. Claim 18 is Obvious Under 35 U.S.C. § 103(a) in View of the Combination of Jurgen, Toyota '599, Davidian, and Tonkin**

Claim 18 is obvious under 35 U.S.C. § 103(a) in view of the combination of Jurgen, Toyota '599, Davidian, and Tonkin. Jurgen, Toyota '599, Davidian, and Tonkin were not cited by the Examiner or the applicants during prosecution. Therefore, the question of whether claim 18 is obvious in view of the combination of Jurgen, Toyota '599, Davidian, and Tonkin was not previously considered. The combination of Jurgen, Toyota '599, Davidian, and Tonkin is closer to the subject matter of claim 18 of the '781 patent than any prior art that was relied upon during prosecution of the '781 patent, and the combination of Jurgen, Toyota '599, Davidian, and Tonkin provides new, non-cumulative technical teachings that were not otherwise provided in any prior art that was relied upon during prosecution of the '781 patent.

Claim 18 depends from claim 17, and adds the limitations of a windshield wiper sensor for indicating whether a windshield wiper of the vehicle is activated and that the memory subsystem stores a second vehicle speed/stopping distance table.

As set forth in more detail above, the combination of Jurgen, Toyota '599, and Davidian raises a substantial new question of patentability affecting claim 17 and renders obvious claim 17.

Tonkin teaches that “information regarding the weather might be obtained for example by enabling the warning system controller to ascertain if the windshield wipers are in use or have been in use recently due to rain.” Page 18, lines 9 to 13. Additionally, Tonkin teaches that “safe stopping distances can be adjusted for prevailing weather conditions.” Page 18, lines 16 to 19. Therefore, Tonkin discloses the adjustment of the vehicle speed/stopping distance tables based upon weather information determined from a windshield wiper sensor.

A person of ordinary skill in the art, at the time the alleged invention of claim 18 of the '781 patent was made, would have found it obvious to combine the teachings of Jurgen, Toyota '599, Davidian, and Tonkin, and, in addition, would have been motivated to do so. Indeed, Jurgen, for example, expressly describes one such motivation: “The motive for using an electronic engine control system is to provide the needed accuracy and adaptability in order to minimize exhaust emissions and fuel consumption, provide optimal driveability for all operating conditions, minimize evaporative emissions, and provide system diagnosis when malfunctions occur.” (Jurgen, Page 12.1). A person of ordinary skill in the art, at the time the alleged invention of claim 18 of the '781 patent was made would have been further motivated to combine the teachings of Jurgen, Toyota '599, Davidian, and Tonkin, to “provide[] the fuel metering and ignition timing precision to minimize fuel consumption (Jurgen, Page 12.4), to “obtain preferable shift positions relating to optimum fuel consumption rate in accordance with . . . data detected” (Toyota '599, Abstract), to provide an “anti-collision system for vehicles” that “computes[] the danger-of-collision distance to the object” (Davidian, Col. 1, line 7 and col. 2, lines 3 to 4), and to “provide safety information for example to drivers of following vehicles” (Tonkin, page 1, lines 4-5). The '781 patent states that its object is to “provide a system which integrates the ability to issue audible warnings which advise the driver to correct operation of the vehicle in a manner which will *enhance the efficient operation* thereof with the ability to automatically take corrective action *if the vehicle is being operated unsafely.*” Col. 1, line 66 to col. 2, line 5. Thus, like the '781 patent, Jurgen, Toyota '599, Davidian, and Tonkin are concerned with, for example, improving fuel efficiency and safety.



Furthermore, as additional evidence that a person of ordinary skill in the art would be motivated to combine the teachings of Jurgen, Toyota '599, Davidian, and Tonkin, Jurgen describes at page xvii:

Automotive electronics as we know it today encompasses a wide variety of devices and systems. Key to them all, and those yet to come, is the ability to sense and measure accurately automotive parameters. Equally important at the output is the ability to initiate control actions accurately in response to commands. In other words, sensors and actuators are the heart of any automotive electronics application. . . .

The importance of sensors and actuators cannot be overemphasized. The future growth of automotive electronics is arguably more dependent on sufficiently accurate and low-cost sensors and actuators than on computers, controls, displays, and other technologies.

Moreover, the combination of these teachings is merely (a) the combination of prior art elements according to known methods to yield predictable results; (b) the simple substitution of known elements for one another to obtain predictable results; (c) the use of known techniques to improve similar devices in the same way; (d) the application of known techniques to known devices ready for improvement to yield predictable results; (e) obvious to try; and (f) known to work in one field of endeavor prompting variations for use in either the same field or a different one based on design incentives or other market forces since the variations are predictable to one of ordinary skill in the art.

Regarding the second vehicle speed/stopping distance table, claim 18 merely recites that the memory subsystem stores a second vehicle speed/stopping distance table, and neither claim 18 nor claim 17, from which claim 18 depends, otherwise mentions the second vehicle speed/stopping distance table. Therefore, the second vehicle speed/stopping distance table is a mere duplication of parts, which has not patentable significance since no new or unexpected result is produced thereby. *See*, M.P.E.P. § 2144.04(VI)(B).

As set forth in the appended charts, the combination of Jurgen, Toyota '599, Davidian, and Tonkin teaches all of the limitations of claim 18 of the '781 patent and therefore renders obvious claim 18 of the '781 patent. Therefore, VWGoA proposes a ground of rejection of claim 18 of the '781 patent under 35 U.S.C. § 103(a) as obvious in view of the combination of Jurgen, Toyota '599, Davidian, and Tonkin.

**16. Claim 18 is Obvious Under 35 U.S.C. § 103(a) in View of the Combination of Jurgen, Volkswagen '070, Davidian, and Tonkin**

Claim 18 is obvious under 35 U.S.C. § 103(a) in view of the combination of Jurgen, Volkswagen '070, Davidian, and Tonkin. Jurgen, Volkswagen '070, Davidian, and Tonkin were not cited by the Examiner or the applicants during prosecution. Therefore, the question of whether claim 18 is obvious in view of the combination of Jurgen, Volkswagen '070, Davidian, and Tonkin was not previously considered. The combination of Jurgen, Volkswagen '070, Davidian, and Tonkin is closer to the subject matter of claim 18 of the '781 patent than any prior art that was relied upon during prosecution of the '781 patent, and the combination of Jurgen, Volkswagen '070, Davidian, and Tonkin provides new, non-cumulative technical teachings that were not otherwise provided in any prior art that was relied upon during prosecution of the '781 patent.

Claim 18 depends from claim 17, and adds the limitations of a windshield wiper sensor for indicating whether a windshield wiper of the vehicle is activated and that the memory subsystem stores a second vehicle speed/stopping distance table.

As set forth in more detail above, the combination of Jurgen, Volkswagen '070, and Davidian raises a substantial new question of patentability affecting claim 17 and renders obvious claim 17.

Tonkin teaches that “information regarding the weather might be obtained for example by enabling the warning system controller to ascertain if the windscreen wipers are in use or have been in use recently due to rain.” Page 18, lines 9 to 13. Additionally, Tonkin teaches that “safe stopping distances can be adjusted for prevailing weather conditions.” Page 18, lines 16 to 19. Therefore, Tonkin discloses the adjustment of the vehicle speed/stopping distance tables based upon weather information determined from a windshield wiper sensor.

A person of ordinary skill in the art, at the time the alleged invention of claim 18 of the '781 patent was made, would have found it obvious to combine the teachings of Jurgen, Volkswagen '070, Davidian, and Tonkin, and, in addition, would have been motivated to do so. Indeed, Jurgen, for example, expressly describes one such motivation: “The motive for using an electronic engine control system is to provide the needed accuracy and adaptability in order to minimize exhaust emissions and fuel consumption, provide optimal driveability for all operating conditions, minimize evaporative emissions, and provide system diagnosis when malfunctions occur.” (Jurgen, Page 12.1). A person of ordinary skill in the art, at the time the alleged invention of claim 18 of the '781 patent was made would have been further motivated to combine the teachings of Jurgen, Volkswagen '070, Davidian, and Tonkin, to

“provide optimal driveability for all operating conditions” (Jurgen, Page 12.1), to “provide[] the fuel metering and ignition timing precision to minimize fuel consumption (Jurgen, Page 12.4), to “provid[e] a device that assists the operator of the internal combustion engine equipped with a conventional transmission . . . for example, in setting an operating point of the engine that is advantageous in terms of fuel consumption” (Volkswagen ’070, Page 5), to provide an “anti-collision system for vehicles” that “computes[] the danger-of-collision distance to the object” (Davidian, Col. 1, line 7 and col. 2, lines 3 to 4), and to “provide safety information for example to drivers of following vehicles” (Tonkin, page 1, lines 4-5). The ’781 patent states that its object is to “provide a system which integrates the ability to issue audible warnings which advise the driver to correct operation of the vehicle in a manner which will *enhance the efficient operation* thereof with the ability to automatically take corrective action *if the vehicle is being operated unsafely.*” Col. 1, line 66 to col. 2, line 5. Thus, like the ’781 patent, Jurgen, Volkswagen ’070, Davidian, and Tonkin are concerned with, for example, improving fuel efficiency and safety.

Furthermore, as additional evidence that a person of ordinary skill in the art would be motivated to combine the teachings of Jurgen, Volkswagen ’070, Davidian, and Tonkin, Jurgen describes at page xvii:

Automotive electronics as we know it today encompasses a wide variety of devices and systems. Key to them all, and those yet to come, is the ability to sense and measure accurately automotive parameters. Equally important at the output is the ability to initiate control actions accurately in response to commands. In other words, sensors and actuators are the heart of any automotive electronics application. . . .

The importance of sensors and actuators cannot be overemphasized. The future growth of automotive electronics is arguably more dependent on sufficiently accurate and low-cost sensors and actuators than on computers, controls, displays, and other technologies.

Moreover, the combination of these teachings is merely (a) the combination of prior art elements according to known methods to yield predictable results; (b) the simple substitution of known elements for one another to obtain predictable results; (c) the use of known techniques to improve similar devices in the same way; (d) the application of known techniques to known devices ready for improvement to yield predictable results; (e) obvious to try; and (f) known to work in one field of endeavor prompting variations for use in either

the same field or a different one based on design incentives or other market forces since the variations are predictable to one of ordinary skill in the art.

Regarding the second vehicle speed/stopping distance table, claim 18 merely recites that the memory subsystem stores a second vehicle speed/stopping distance table, and neither claim 18 nor claim 17, from which claim 18 depends, otherwise mentions the second vehicle speed/stopping distance table. Therefore, the second vehicle speed/stopping distance table is a mere duplication of parts, which has not patentable significance since no new or unexpected result is produced thereby. *See*, M.P.E.P. § 2144.04(VI)(B).

As set forth in the appended charts, the combination of Jurgén, Volkswagen '070, Davidian, and Tonkin teaches all of the limitations of claim 18 of the '781 patent and therefore renders obvious claim 18 of the '781 patent. Therefore, VWGoA proposes a ground of rejection of claim 18 of the '781 patent under 35 U.S.C. § 103(a) as obvious in view of the combination of Jurgén, Volkswagen '070, Davidian, and Tonkin.

**17. Claim 18 is Obvious Under 35 U.S.C. § 103(a) in View of the Combination of Jurgén, Saturn '452, Davidian, and Tonkin**

Claim 18 is obvious under 35 U.S.C. § 103(a) in view of the combination of Jurgén, Saturn '452, Davidian, and Tonkin. Jurgén, Saturn '452, Davidian, and Tonkin were not cited by the Examiner or the applicants during prosecution. Therefore, the question of whether claim 18 is obvious in view of the combination of Jurgén, Saturn '452, Davidian, and Tonkin was not previously considered. The combination of Jurgén, Saturn '452, Davidian, and Tonkin is closer to the subject matter of claim 18 of the '781 patent than any prior art that was relied upon during prosecution of the '781 patent, and the combination of Jurgén, Saturn '452, Davidian, and Tonkin provides new, non-cumulative technical teachings that were not otherwise provided in any prior art that was relied upon during prosecution of the '781 patent.

Claim 18 depends from claim 17, and adds the limitations of a windshield wiper sensor for indicating whether a windshield wiper of the vehicle is activated and that the memory subsystem stores a second vehicle speed/stopping distance table.

As set forth in more detail above, the combination of Jurgén, Saturn '452, and Davidian raises a substantial new question of patentability affecting claim 17 and renders obvious claim 17.

Tonkin teaches that “information regarding the weather might be obtained for example by enabling the warning system controller to ascertain if the windshield wipers are in use or have been in use recently due to rain.” Page 18, lines 9 to 13. Additionally, Tonkin teaches that “safe stopping distances can be adjusted for prevailing weather conditions.”

Page 18, lines 16 to 19. Therefore, Tonkin discloses the adjustment of the vehicle speed/stopping distance tables based upon weather information determined from a windshield wiper sensor.

A person of ordinary skill in the art, at the time the alleged invention of claim 18 of the '781 patent was made, would have found it obvious to combine the teachings of Jurgen, Saturn '452, Davidian, and Tonkin, and, in addition, would have been motivated to do so. Indeed, Jurgen, for example, expressly describes one such motivation: "The motive for using an electronic engine control system is to provide the needed accuracy and adaptability in order to minimize exhaust emissions and fuel consumption, provide optimal driveability for all operating conditions, minimize evaporative emissions, and provide system diagnosis when malfunctions occur." (Jurgen, Page 12.1). A person of ordinary skill in the art, at the time the alleged invention of claim 18 of the '781 patent was made would have been further motivated to combine the teachings of Jurgen, Saturn '452, Davidian, and Tonkin, to "provide[] the fuel metering and ignition timing precision to minimize fuel consumption (Jurgen, Page 12.4), to provide a "means for indicating to the operator a point in operation for upshifting to the next higher gear" (Saturn '452, Abstract), to provide "an improved method of determining shift points and indicating the same to a vehicle operator in order to maximize real driving fuel economy" (Saturn '452, col. 1, lines 44 to 47). to provide an "anti-collision system for vehicles" that "computes[] the danger-of-collision distance to the object" (Davidian, Col. 1, line 7 and col. 2, lines 3 to 4), and to "provide safety information for example to drivers of following vehicles" (Tonkin, page 1, lines 4-5). The '781 patent states that its object is to "provide a system which integrates the ability to issue audible warnings which advise the driver to correct operation of the vehicle in a manner which will *enhance the efficient operation* thereof with the ability to automatically take corrective action *if the vehicle is being operated unsafely.*" Col. 1, line 66 to col. 2, line 5. Thus, like the '781 patent, Jurgen, Saturn '452, Davidian, and Tonkin are concerned with, for example, improving fuel efficiency and safety.

Furthermore, as additional evidence that a person of ordinary skill in the art would be motivated to combine the teachings of Jurgen, Saturn '452, Davidian, and Tonkin, Jurgen describes at page xvii:

Automotive electronics as we know it today encompasses a wide variety of devices and systems. Key to them all, and those yet to come, is the ability to sense and measure accurately automotive parameters. Equally important at the output is the ability to initiate control actions accurately

in response to commands. In other words, sensors and actuators are the heart of any automotive electronics application. . . .

The importance of sensors and actuators cannot be overemphasized. The future growth of automotive electronics is arguably more dependent on sufficiently accurate and low-cost sensors and actuators than on computers, controls, displays, and other technologies.

Moreover, the combination of these teachings is merely (a) the combination of prior art elements according to known methods to yield predictable results; (b) the simple substitution of known elements for one another to obtain predictable results; (c) the use of known techniques to improve similar devices in the same way; (d) the application of known techniques to known devices ready for improvement to yield predictable results; (e) obvious to try; and (f) known to work in one field of endeavor prompting variations for use in either the same field or a different one based on design incentives or other market forces since the variations are predictable to one of ordinary skill in the art.

Regarding the second vehicle speed/stopping distance table, claim 18 merely recites that the memory subsystem stores a second vehicle speed/stopping distance table, and neither claim 18 nor claim 17, from which claim 18 depends, otherwise mentions the second vehicle speed/stopping distance table. Therefore, the second vehicle speed/stopping distance table is a mere duplication of parts, which has not patentable significance since no new or unexpected result is produced thereby. *See*, M.P.E.P. § 2144.04(VI)(B).

As set forth in the appended charts, the combination of Jurgen, Saturn '452, Davidian, and Tonkin teaches all of the limitations of claim 18 of the '781 patent and therefore renders obvious claim 18 of the '781 patent. Therefore, VWGoA proposes a ground of rejection of claim 18 of the '781 patent under 35 U.S.C. § 103(a) as obvious in view of the combination of Jurgen, Saturn '452, Davidian, and Tonkin.

**18. Claims 24 and 25 are Obvious Under 35 U.S.C. § 103(a) in View of the Combination of Jurgen, Saturn '452, Davidian and Chasteen**

Claims 24 and 25 are obvious under 35 U.S.C. § 103(a) in view of the combination of Jurgen, Saturn '452, Davidian, and Chasteen. Although Chasteen was cited by the Examiner during prosecution of the '781 patent, Jurgen, Saturn '452, and Davidian were not cited by the Examiner or the applicants during prosecution. Thus, the question of whether claims 24 and 25 are obvious in view of the combination of Jurgen, Saturn '452, Davidian and Chasteen was not previously considered. The combination of Jurgen, Saturn '452, Davidian, and

Chasteen is closer to the subject matter of claims 24 and 25 of the '781 patent than any prior art that was relied upon during prosecution of the '781 patent. The combination of Jurgen, Saturn '452, Davidian, and Chasteen provides new, non-cumulative technical teachings that were not otherwise provided in any prior art that was relied upon during prosecution of the '781 patent.

As more fully explained above, the Examiner concluded that claim 23, from which claims 24 and 25 depend, was allowable over the prior art cited during prosecution on the basis that the prior art does not teach an upshift notification circuit, wherein the processor determines, based upon data received from sensors, when to activate said upshift and/or downshift notification circuits, and there is no indication in the prosecution history that either claim 24 or claim 25 was considered allowable over the cited prior art for any reason other than their dependency from claim 23.

As set forth in more detail above, the combination of Jurgen, Saturn '452, and Davidian raises a substantial new question of patentability affecting claim 23 and renders obvious claim 23 under 35 U.S.C. § 103(a).

During prosecution of the '781 patent, the Examiner determined that a person of ordinary skill in the art would have found the added limitations of dependent claims 24 and 25 obvious in view of the teachings of Chasteen.<sup>17</sup> For example, in rejecting claim 24 as obvious in view of the combination of Chasteen and Doi et al., the Examiner found that:

Chasteen discloses the sensors as discussed for sensing the signals and a processor and compare [sic] manifold pressure for activating the fuel injection. Chasteen discloses the speed (RPM) and throttle position are determined to be greater than 0 (increasing) and the CPU provides a control command to the engine fuel injector to prime the engine (See column 11, lines 22-33) therefore on [sic] would consider increasing and decreasing the speed and throttle for adjusting the fuel injector for supplying fuel to the engine.

In the Amendment filed by the applicants in response to the Office Action containing the foregoing findings, the applicants did not amend claim 24 or 25 and did not present any arguments against the Examiner's findings. Instead, and as indicate above, the applicants amended claim 23, from which claims 24 and 25 depend, to include the upshift notification circuit limitations that the Examiner found missing from the prior art.

---

<sup>17</sup> To render a claim obvious, "[t]he prior art reference (or references when combined) need not teach or suggest all of the claim limitations." M.P.E.P. § 2141.

Jurgen discloses an electronic engine control system that receives sensor inputs, evaluates them, and determines the necessary outputs to provide for optimal driveability. (Jurgen, page 12.1). Jurgen also discloses that these sensors monitor engine speed (page 7.6), road speed (pages 7.8, 14.3), manifold pressure (pages 2.5, 2.7), throttle position (page 12.21). Jurgen also teaches that the use of processor subsystems to receive inputs from these sensors was known. (Pages 12.1, 13.6, 22.6). “During the entire operating time of the vehicle, the ECUs are constantly supervising the sensors they are connected to.” (Page 22.6). Indeed, Jurgen discloses a diagram of these hardware parts:

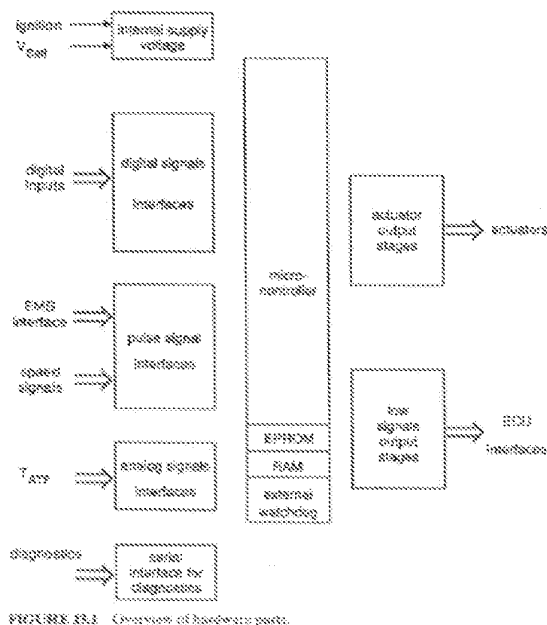

Jurgen, therefore, teaches “means for determining when road speed for said vehicle is increasing[/~~decreasing~~],” means for determining when throttle position for said vehicle is increasing[/~~decreasing~~],” and “means for determining when throttle position for said vehicle is increasing[/~~decreasing~~],” as claimed in claims 24, 25, and 27.

Jurgen teaches a fuel overinjection notification circuit, which issues a notification that excessive fuel is being supplied to the engine of the vehicle. For example, the ECU taught by Jurgen can shut off fuel in certain situations by evaluating the throttle position, engine RPM, and vehicle speed. (Page 12.4). Additionally, the ECU can shut off fuel injectors when a maximum speed is achieved (page 12.14). The ECU provides the fuel overinjection notification to the fuel injectors when a fuel cutoff state is reached. Based upon the Examiner’s statements during the original prosecution, it would have been obvious to one of ordinary skill in the art to enable the fuel overinjection notification circuit based upon sensor



inputs. For example, the combination of the ECU, which monitors all of the vehicle's sensors (see above) and the TCU, which stores the shift maps, can send notification circuits to the fuel injectors and/or the transmission in order to alleviate a fuel overinjection condition.

Claim 25 describes that the upshift notification circuit is activated based upon the same types of sensor inputs. For example, claim 25 requires that "said processor subsystem activating said upshift notification circuit if both road speed and throttle position for said vehicle are increasing, manifold pressure for said vehicle is at or below said manifold pressure set point and engine speed for said vehicle is at or above said RPM set point." Because Saturn '452 discloses an upshift notification circuit triggered by a processor in response to sensors (*see* col. 2, lines 42 to 55) the Examiner's statements that the fuel overinjection circuit triggered based upon sensor inputs would have been obvious in view of Chasteen also apply to the upshift notification circuit in view of Saturn '452.

A person of ordinary skill in the art, at the time the alleged inventions of claims 24 and 25 of the '781 patent were made, would have found it obvious to combine the teachings of Jorgen, Saturn '452, Davidian, and Chasteen, and, in addition, would have been motivated to do so. Indeed, Jorgen, for example, expressly describes one such motivation: "The motive for using an electronic engine control system is to provide the needed accuracy and adaptability in order to minimize exhaust emissions and fuel consumption, provide optimal driveability for all operating conditions, minimize evaporative emissions, and provide system diagnosis when malfunctions occur." (Jorgen, Page 12.1). A person of ordinary skill in the art, at the time the alleged inventions of claims 24 and 25 of the '781 patent were made would have been further motivated to combine the teachings of Jorgen, Saturn '452, Davidian, and Chasteen, to "provide optimal driveability for all operating conditions" (Jorgen, Page 12.1), to "provide[] the fuel metering and ignition timing precision to minimize fuel consumption (Jorgen, Page 12.4), to provide a "means for indicating to the operator a point in operation for upshifting to the next higher gear" (Saturn '452, Abstract), to provide "an improved method of determining shift points and indicating the same to a vehicle operator in order to maximize real driving fuel economy" (Saturn '452, col. 1, lines 44 to 47), to provide an "anti-collision system for vehicles" that "computes[] the danger-of-collision distance to the object" (Davidian, Col. 1, line 7 and col. 2, lines 3 to 4), and to indicate the "optimum fuel requirements for the engine" (Chasteen, col. 2, lines 48 to 54). The '781 patent states that its object is to "provide a system which integrates the ability to issue audible warnings which advise the driver to correct operation of the vehicle in a manner which will *enhance the efficient operation* thereof with the ability to automatically take corrective

action *if the vehicle is being operated unsafely.*” Col. 1, line 66 to col. 2, line 5. Thus, like the ’781 patent, Jorgen, Saturn ’452, Davidian, and Chasteen are concerned with, for example, improving fuel efficiency and safety.

Furthermore, as additional evidence that a person of ordinary skill in the art would be motivated to combine the teachings of Jorgen, Saturn ’452, Davidian, and Chasteen, Jorgen describes at page xvii:

Automotive electronics as we know it today encompasses a wide variety of devices and systems. Key to them all, and those yet to come, is the ability to sense and measure accurately automotive parameters. Equally important at the output is the ability to initiate control actions accurately in response to commands. In other words, sensors and actuators are the heart of any automotive electronics application. . . .

The importance of sensors and actuators cannot be overemphasized. The future growth of automotive electronics is arguably more dependent on sufficiently accurate and low-cost sensors and actuators than on computers, controls, displays, and other technologies.

Moreover, the combination of these teachings is merely (a) the combination of prior art elements according to known methods to yield predictable results; (b) the simple substitution of known elements for one another to obtain predictable results; (c) the use of known techniques to improve similar devices in the same way; (d) the application of known techniques to known devices ready for improvement to yield predictable results; (e) obvious to try; and (f) known to work in one field of endeavor prompting variations for use in either the same field or a different one based on design incentives or other market forces since the variations are predictable to one of ordinary skill in the art.

As set forth in the appended charts, the combination of Jorgen, Saturn ’452, Davidian, and Chasteen teaches all of the limitations of claims 24 and 25 of the ’781 patent and therefore renders obvious claims 24 and 25 of the ’781 patent. Therefore, VWGoA proposes a ground of rejection of claims 24 and 25 of the ’781 patent under 35 U.S.C. § 103(a) as obvious in view of the combination of Jorgen, Saturn ’452, Davidian, and Chasteen.

**19. Claims 24, 25, and 27 are Obvious Under 35 U.S.C. § 103(a) in View of the Combination of Jorgen, Toyota ’599, Davidian and Chasteen**

Claims 24, 25, and 27 are obvious under 35 U.S.C. § 103(a) in view of the combination of Jorgen, Toyota ’599, Davidian and Chasteen. Although Chasteen was cited

by the Examiner during prosecution of the '781 patent, Jurgén, Toyota '599, and Davidian were not cited by the Examiner or the applicants during prosecution. Thus, the question of whether claims 24, 25, and 27 are obvious in view of the combination of Jurgén, Toyota '599, Davidian and Chasteen was not previously considered. The combination of Jurgén, Toyota '599, Davidian, and Chasteen is closer to the subject matter of claims 24, 25, and 27 of the '781 patent than any prior art that was relied upon during prosecution of the '781 patent. The combination of Jurgén, Toyota '599, Davidian, and Chasteen provides new, non-cumulative technical teachings that were not otherwise provided in any prior art that was relied upon during prosecution of the '781 patent.

As more fully explained above, the Examiner concluded that claims 23 and 26, from which claims 24, 25, and 27 depend, were allowable over the prior art cited during prosecution on the basis that the prior art does not teach upshift and/or downshift notification circuits, wherein the processor determines, based upon data received from sensors, when to activate said upshift and/or downshift notification circuits, and there is no indication in the prosecution history that any of dependent claims 24, 25, and 27 were considered allowable over the cited prior art for any reason other than their dependency from claim 23 or 26.

As set forth in more detail above, the combination of Jurgén, Toyota '599, and Davidian raises a substantial new question of patentability affecting claims 23 and 26 and renders obvious claims 23 and 26 under 35 U.S.C. § 103(a).

During prosecution of the '781 patent, the Examiner determined that a person of ordinary skill in the art would have found the added limitations of dependent claims 24, 25, and 27 obvious in view of the teachings of Chasteen.<sup>18</sup> For example, in rejecting claim 24 as obvious in view of the combination of Chasteen and Doi et al., the Examiner found that:

Chasteen discloses the sensors as discussed for sensing the signals and a processor and compare [sic] manifold pressure for activating the fuel injection. Chasteen discloses the speed (RPM) and throttle position are determined to be greater than 0 (increasing) and the CPU provides a control command to the engine fuel injector to prime the engine (See column 11, lines 22-33) therefore on [sic] would consider increasing and decreasing the speed and throttle for adjusting the fuel injector for supplying fuel to the engine.

---

<sup>18</sup> To render a claim obvious, “[t]he prior art reference (or references when combined) need not teach or suggest all of the claim limitations.” M.P.E.P. § 2141.

In the Amendment filed by the applicants in response to the Office Action containing the foregoing findings, the applicants did not amend claim 24, 25, or 27 and did not present any arguments against the Examiner’s findings. Instead, and as indicate above, the applicants amended claim 23, from which claims 24 and 25 depend, to include the upshift notification circuit limitations that the Examiner found missing from the prior art, and rewrote claim 26, from which, claim 27 depends, in effect adding the downshift notification circuit limitations that the Examiner found missing from the prior art.<sup>19</sup>

Jurgen discloses an electronic engine control system that receives sensor inputs, evaluates them, and determines the necessary outputs to provide for optimal driveability. (Jurgen, page 12.1). Jurgen also discloses that these sensors monitor engine speed (page 7.6), road speed (pages 7.8, 14.3), manifold pressure (pages 2.5, 2.7), throttle position (page 12.21). Jurgen also teaches that the use of processor subsystems to receive inputs from these sensors was known. (Pages 12.1, 13.6, 22.6). “During the entire operating time of the vehicle, the ECUs are constantly supervising the sensors they are connected to.” (Page 22.6). Indeed, Jurgen discloses a diagram of these hardware parts:

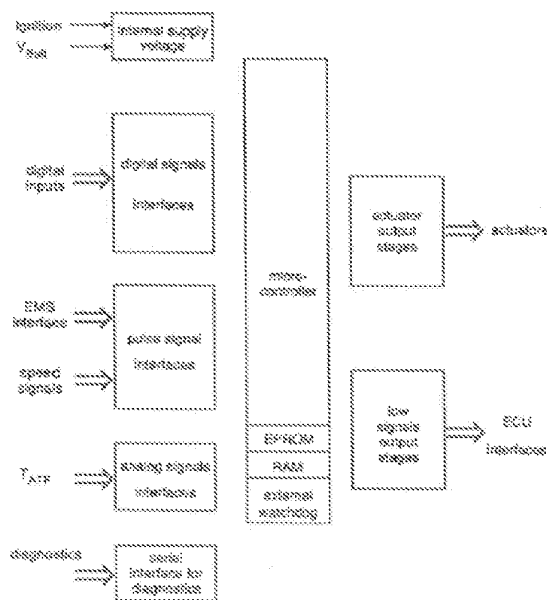

FIGURE 11.3 Overview of hardware parts.

<sup>19</sup> See, e.g., *Honeywell Int'l v. Hamilton Sundstrand Corp.*, 370 F.3d 1131, 1144 (Fed. Cir. 2004) (“[D]ependent claims 4, 8, and 19 were rewritten into independent form, and the original independent claims were cancelled, effectively adding the inlet guide vane limitations [of dependent claims 4, 8 and 19] to the claimed invention.”).

Jurgen, therefore, teaches “means for determining when road speed for said vehicle is increasing[/decreasing],” means for determining when throttle position for said vehicle is increasing[/decreasing],” and “means for determining when throttle position for said vehicle is increasing[/decreasing]” as claimed in claims 24, 25, and 27.

Jurgen teaches a fuel overinjection notification circuit, which issues a notification that excessive fuel is being supplied to the engine of the vehicle. For example, the ECU taught by Jurgen can shut off fuel in certain situations by evaluating the throttle position, engine RPM, and vehicle speed. (Page 12.4). Additionally, the ECU can shut off fuel injectors when a maximum speed is achieved (page 12.14). The ECU provides the fuel overinjection notification to the fuel injectors when a fuel cutoff state is reached. Based upon the Examiner’s statements during the original prosecution, it would have been obvious to one of ordinary skill in the art to enable the fuel overinjection notification circuit based upon sensor inputs. For example, the combination of the ECU, which monitors all of the vehicle’s sensors (see above) and the TCU, which stores the shift maps, can send notification circuits to the fuel injectors and/or the transmission in order to alleviate a fuel overinjection condition.

Claims 25 and 27 require that the upshift and/or downshift notification circuits are activated based upon the same types of sensor inputs. For example, claim 25 requires that “said processor subsystem activating said upshift notification circuit if both road speed and throttle position for said vehicle are increasing, manifold pressure for said vehicle is at or below said manifold pressure set point and engine speed for said vehicle is at or above said RPM set point.” Because Toyota ’599 discloses both upshift and downshift notification circuits triggered by a processor in response to sensors (*see* col. 5, line 63 to col. 6, line 2), the Examiner’s statements that the fuel overinjection circuit triggered based upon sensor inputs would have been obvious in view of Chasteen also apply to the upshift/downshift notification circuits in view of Toyota ’599.

A person of ordinary skill in the art, at the time the alleged inventions of claims 24, 25, and 27 of the ’781 patent were made, would have found it obvious to combine the teachings of Jurgen, Toyota ’599, Davidian, and Chasteen, and, in addition, would have been motivated to do so. Indeed, Jurgen, for example, expressly describes one such motivation: “The motive for using an electronic engine control system is to provide the needed accuracy and adaptability in order to minimize exhaust emissions and fuel consumption, provide optimal driveability for all operating conditions, minimize evaporative emissions, and provide system diagnosis when malfunctions occur.” (Jurgen, Page 12.1). A person of ordinary skill in the art, at the time the alleged inventions of claims 24, 25, and 27 of the ’781

patent were made would have been further motivated to combine the teachings of Jurgen, Toyota '599, Davidian, and Chasteen, to “provide optimal driveability for all operating conditions” (Jurgen, Page 12.1), to “provide[] the fuel metering and ignition timing precision to minimize fuel consumption (Jurgen, Page 12.4), to “obtain preferable shift positions relating to optimum fuel consumption rate in accordance with [] data detected” (Toyota '599, Abstract), to provide an “anti-collision system for vehicles” that “computes[] the danger-of-collision distance to the object” (Davidian, Col. 1, line 7 and col. 2, lines 3 to 4), and to indicate the “optimum fuel requirements for the engine” (Chasteen, col. 2, lines 48 to 54). The '781 patent states that its object is to “provide a system which integrates the ability to issue audible warnings which advise the driver to correct operation of the vehicle in a manner which will *enhance the efficient operation* thereof with the ability to automatically take corrective action *if the vehicle is being operated unsafely.*” Col. 1, line 66 to col. 2, line 5. Thus, like the '781 patent, Jurgen, Toyota '599, Davidian, and Chasteen are concerned with, for example, improving fuel efficiency and safety.

Furthermore, as additional evidence that a person of ordinary skill in the art would be motivated to combine the teachings of Jurgen, Toyota '599, Davidian, and Chasteen, Jurgen describes at page xvii:

Automotive electronics as we know it today encompasses a wide variety of devices and systems. Key to them all, and those yet to come, is the ability to sense and measure accurately automotive parameters. Equally important at the output is the ability to initiate control actions accurately in response to commands. In other words, sensors and actuators are the heart of any automotive electronics application. . . .

The importance of sensors and actuators cannot be overemphasized. The future growth of automotive electronics is arguably more dependent on sufficiently accurate and low-cost sensors and actuators than on computers, controls, displays, and other technologies.

Moreover, the combination of these teachings is merely (a) the combination of prior art elements according to known methods to yield predictable results; (b) the simple substitution of known elements for one another to obtain predictable results; (c) the use of known techniques to improve similar devices in the same way; (d) the application of known techniques to known devices ready for improvement to yield predictable results; (e) obvious to try; and (f) known to work in one field of endeavor prompting variations for use in either

the same field or a different one based on design incentives or other market forces since the variations are predictable to one of ordinary skill in the art.

As set forth in the appended charts, the combination of Jurgén, Toyota '599, Davidian, and Chasteen teaches all of the limitations of claims 24, 25, and 27 of the '781 patent and therefore renders obvious claims 24, 25, and 27 of the '781 patent. Therefore, VWGoA proposes a ground of rejection of claims 24, 25, and 27 of the '781 patent under 35 U.S.C. § 103(a) as obvious in view of the combination of Jurgén, Toyota '599, Davidian, and Chasteen.

**20. Claims 24, 25, and 27 are Obvious Under 35 U.S.C. § 103(a) in View of the Combination of Jurgén, Volkswagen '070, Davidian and Chasteen**

Claims 24, 25, and 27 are obvious under 35 U.S.C. § 103(a) in view of the combination of Jurgén, Volkswagen '070, Davidian and Chasteen. Although Chasteen was cited by the Examiner during prosecution of the '781 patent, Jurgén, Volkswagen '070, and Davidian were not cited by the Examiner or the applicants during prosecution. Thus, the question of whether claims 24, 25, and 27 are obvious in view of the combination of Jurgén, Volkswagen '070, Davidian and Chasteen was not previously considered. The combination of Jurgén, Volkswagen '070, Davidian, and Chasteen is closer to the subject matter of claims 24, 25, and 27 of the '781 patent than any prior art that was relied upon during prosecution of the '781 patent. The combination of Jurgén, Volkswagen '070, Davidian, and Chasteen provides new, non-cumulative technical teachings that were not otherwise provided in any prior art that was relied upon during prosecution of the '781 patent.

As more fully explained above, the Examiner concluded that claims 23 and 26, from which claims 24, 25, and 27 depend, were allowable over the prior art cited during prosecution on the basis that the prior art does not teach upshift and/or downshift notification circuits, wherein the processor determines, based upon data received from sensors, when to activate said upshift and/or downshift notification circuits, and there is no indication in the prosecution history that any of dependent claims 24, 25, and 27 were considered allowable over the cited prior art for any reason other than their dependency from claim 23 or 26.

As set forth in more detail above, the combination of Jurgén, Volkswagen '070, and Davidian raises a substantial new question of patentability affecting claims 23 and 26 and renders obvious claims 23 and 26 under 35 U.S.C. § 103(a).

During prosecution of the '781 patent, the Examiner determined that a person of ordinary skill in the art would have found the added limitations of dependent claims 24, 25,

and 27 obvious in view of the teachings of Chasteen.<sup>20</sup> For example, in rejecting claim 24 as obvious in view of the combination of Chasteen and Doi et al., the Examiner found that:

Chasteen discloses the sensors as discussed for sensing the signals and a processor and compare [sic] manifold pressure for activating the fuel injection. Chasteen discloses the speed (RPM) and throttle position are determined to be greater than 0 (increasing) and the CPU provides a control command to the engine fuel injector to prime the engine (See column 11, lines 22-33) therefore on [sic] would consider increasing and decreasing the speed and throttle for adjusting the fuel injector for supplying fuel to the engine.

In the Amendment filed by the applicants in response to the Office Action containing the foregoing findings, the applicants did not amend claim 24, 25, or 27 and did not present any arguments against the Examiner's findings. Instead, and as indicate above, the applicants amended claim 23, from which claims 24 and 25 depend, to include the upshift notification circuit limitations that the Examiner found missing from the prior art, and rewrote claim 26, from which, claim 27 depends, in effect adding the downshift notification circuit limitations that the Examiner found missing from the prior art.<sup>21</sup>

Jurgen discloses an electronic engine control system that receives sensor inputs, evaluates them, and determines the necessary outputs to provide for optimal driveability. (Jurgen, page 12.1). Jurgen also discloses that these sensors monitor engine speed (page 7.6), road speed (pages 7.8, 14.3), manifold pressure (pages 2.5, 2.7), throttle position (page 12.21). Jurgen also teaches that the use of processor subsystems to receive inputs from these sensors was known. (Pages 12.1, 13.6, 22.6). "During the entire operating time of the vehicle, the ECUs are constantly supervising the sensors they are connected to." (Page 22.6). Indeed, Jurgen discloses a diagram of these hardware parts:

---

<sup>20</sup> To render a claim obvious, "[t]he prior art reference (or references when combined) need not teach or suggest all of the claim limitations." M.P.E.P. § 2141.

<sup>21</sup> See, e.g., *Honeywell Int'l v. Hamilton Sundstrand Corp.*, 370 F.3d 1131, 1144 (Fed. Cir. 2004) ("[D]ependent c]laims 4, 8, and 19 were rewritten into independent form, and the original independent claims were cancelled, effectively adding the inlet guide vane limitations [of dependent claims 4, 8 and 19] to the claimed invention.").



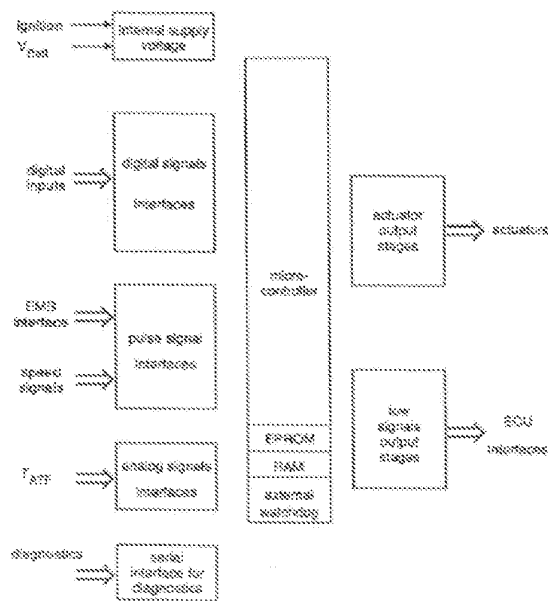

FIGURE 23.3 Overview of hardware parts.

Jurgen, therefore, teaches “means for determining when road speed for said vehicle is increasing[/decreasing],” means for determining when throttle position for said vehicle is increasing[/decreasing],” and “means for determining when throttle position for said vehicle is increasing[/decreasing]” as claimed in claims 24, 25, and 27.

Volkswagen '070 acknowledges that automobile instrument panels that display fuel economy are in the prior art. For example, Volkswagen '070 describes at page 9:

It is useful in addition to this device, a display of the route-specific fuel consumption is provided in a vehicle. Such display devices are known per se; they generally utilize the *induction manifold vacuum* as a measure of the fuel consumption. . . . In this case it is useful to integrate the signal transmitters denoted by 4 and 5 in Figure 2 into the instrument of the fuel consumption display, as sketched in Figure 3. During standard driving operation, pointer 30 of the fuel consumption display sweeps scale 31, while it is hidden behind cover 32 during an idling operation or at full-load accelerations. Incorporated in the scale is arrow 33, which constitutes part of a signal transmitter requesting upshifting, which therefore corresponds to signal transmitter 4 in Figure 2.

(emphasis added)

Thus, by describing a fuel consumption display that indicates full-load acceleration, Volkswagen '070 teaches “means for determining when road speed for said vehicle is increasing[/decreasing],” means for determining when throttle position for said vehicle is

increasing[/decreasing],” “means for determining when throttle position for said vehicle is increasing[/decreasing],” and the processor activating the fuel overinjection circuit based upon measurements from these sensors as claimed in claims 2, 4, 5, 8, 10, 12, and 15.

Jurgen teaches a fuel overinjection notification circuit, which issues a notification that excessive fuel is being supplied to the engine of the vehicle. For example, the ECU taught by Jurgen can shut off fuel in certain situations by evaluating the throttle position, engine RPM, and vehicle speed. (Page 12.4). Additionally, the ECU can shut off fuel injectors when a maximum speed is achieved (page 12.14). The ECU provides the fuel overinjection notification to the fuel injectors when a fuel cutoff state is reached. Based upon the Examiner’s statements during the original prosecution, it would have been obvious to one of ordinary skill in the art to enable the fuel overinjection notification circuit based upon sensor inputs. For example, the combination of the ECU, which monitors all of the vehicle’s sensors (see above) and the TCU, which stores the shift maps, can send notification circuits to the fuel injectors and/or the transmission in order to alleviate a fuel overinjection condition.

Claims 25 and 27 require that the upshift and/or downshift notification circuits are activated based upon the same types of sensor inputs. For example, claim 25 requires that “said processor subsystem activating said upshift notification circuit if both road speed and throttle position for said vehicle are increasing, manifold pressure for said vehicle is at or below said manifold pressure set point and engine speed for said vehicle is at or above said RPM set point.” Because Volkswagen ’070 discloses both upshift and downshift notification circuits triggered by a processor in response to sensors (*see* pages 6–8), the Examiner’s statements that the fuel overinjection circuit triggered based upon sensor inputs would have been obvious in view of Chasteen also apply to the upshift/downshift notification circuits in view of Volkswagen ’070.

A person of ordinary skill in the art, at the time the alleged inventions of claims 24, 25, and 27 of the ’781 patent were made, would have found it obvious to combine the teachings of Jurgen, Volkswagen ’070, Davidian, and Chasteen, and, in addition, would have been motivated to do so. Indeed, Jurgen, for example, expressly describes one such motivation: “The motive for using an electronic engine control system is to provide the needed accuracy and adaptability in order to minimize exhaust emissions and fuel consumption, provide optimal driveability for all operating conditions, minimize evaporative emissions, and provide system diagnosis when malfunctions occur.” (Jurgen, Page 12.1). A person of ordinary skill in the art, at the time the alleged inventions of claims 24, 25, and 27 of the ’781 patent were made would have been further motivated to combine the teachings of

Jurgen, Volkswagen '070, Davidian, and Chasteen, to “provide optimal driveability for all operating conditions” (Jurgen, Page 12.1), to “provide[] the fuel metering and ignition timing precision to minimize fuel consumption (Jurgen, Page 12.4), to “provid[e] a device that assists the operator of the internal combustion engine equipped with a conventional transmission . . . for example, in setting an operating point of the engine that is advantageous in terms of fuel consumption” (Volkswagen '070, Page 5), to provide an “anti-collision system for vehicles” that “computes[] the danger-of-collision distance to the object” (Davidian, Col. 1, line 7 and col. 2, lines 3 to 4), and to indicate the “optimum fuel requirements for the engine” (Chasteen, col. 2, lines 48 to 54). The '781 patent states that its object is to “provide a system which integrates the ability to issue audible warnings which advise the driver to correct operation of the vehicle in a manner which will *enhance the efficient operation* thereof with the ability to automatically take corrective action *if the vehicle is being operated unsafely.*” Col. 1, line 66 to col. 2, line 5. Thus, like the '781 patent, Jurgen, Volkswagen '070, Davidian, and Chasteen are concerned with, for example, improving fuel efficiency and safety.

Furthermore, as additional evidence that a person of ordinary skill in the art would be motivated to combine the teachings of Jurgen, Volkswagen '070, Davidian, and Chasteen, Jurgen describes at page xvii:

Automotive electronics as we know it today encompasses a wide variety of devices and systems. Key to them all, and those yet to come, is the ability to sense and measure accurately automotive parameters. Equally important at the output is the ability to initiate control actions accurately in response to commands. In other words, sensors and actuators are the heart of any automotive electronics application. . . .

The importance of sensors and actuators cannot be overemphasized. The future growth of automotive electronics is arguably more dependent on sufficiently accurate and low-cost sensors and actuators than on computers, controls, displays, and other technologies.

Moreover, the combination of these teachings is merely (a) the combination of prior art elements according to known methods to yield predictable results; (b) the simple substitution of known elements for one another to obtain predictable results; (c) the use of known techniques to improve similar devices in the same way; (d) the application of known techniques to known devices ready for improvement to yield predictable results; (e) obvious to try; and (f) known to work in one field of endeavor prompting variations for use in either

the same field or a different one based on design incentives or other market forces since the variations are predictable to one of ordinary skill in the art.

As set forth in the appended charts, the combination of Jurgen, Volkswagen '070, Davidian, and Chasteen teaches all of the limitations of claims 24, 25, and 27 of the '781 patent and therefore renders obvious claims 24, 25, and 27 of the '781 patent. Therefore, VWGoA proposes a ground of rejection of claims 24, 25, and 27 of the '781 patent under 35 U.S.C. § 103(a) as obvious in view of the combination of Jurgen, Volkswagen '070, Davidian, and Chasteen.

**21. Claim 32 is Obvious Under 35 U.S.C. § 103(a) in View of the Combination of Davidian and Tonkin**

Claim 32 is obvious under 35 U.S.C. § 103(a) in view of the combination of Davidian, Chasteen, and Tonkin. Neither Davidian nor Tonkin was cited by the Examiner or the applicants during prosecution of the '781 patent. Therefore, the question of whether claim 32 is obvious in view of the combination of Davidian and Tonkin was not previously considered. The combination of Davidian and Tonkin is closer to the subject matter of claim 32 of the '781 patent than any prior art that was relied upon during prosecution of the '781 patent, and the combination of Davidian and Tonkin provides new, non-cumulative technical teachings that were not otherwise provided in any prior art that was relied upon during prosecution of the '781 patent.

Claim 32 depends from claim 31. As set forth in more detail above, Davidian raises a substantial new question of patentability affecting claim 31 and anticipates claim 31 under 35 U.S.C. § 102(b).

Claim 32 adds the limitations of a windshield wiper sensor for indicating whether a windshield wiper of the vehicle is activated and that the memory subsystem further stores a second vehicle speed/stopping distance table. During prosecution of the '781 patent, the applicants stated that “the windshield wiper sensor [of claim 32] is not used to inform the operator as to whether the windshield wipers are on or off.” Rather, according to the applicants, “the sensor is used by the processor subsystem to classify road conditions as either ‘dry’ or ‘wet’.” Davidian describes that the automatic sensors of the vehicle include a rain sensor 16 (col. 4, line 67 to col. 5, line 2), and Tonkin describes that safe stopping distances can be adjusted for prevailing weather conditions, and that information regarding the weather may be obtained by the warning system controller ascertaining if the windscreen wipers are in use or have been in use recently due to rain (col. 18, lines 9 to 16). Thus, the

combination of Davidian and Tonkin teaches a windshield wiper sensor for indicating whether a windshield wiper of the vehicle is activated, as described in claim 32.

Regarding the memory subsystem storing a second vehicle speed/stopping distance table, Tonkin describes that “safe stopping distances can be adjusted for prevailing weather conditions, again by providing stored values according to weather and possibly for different severities of poor weather.” Page 18, lines 16 to 19. Thus, Tonkin teaches a memory subsystem storing a second vehicle speed/stopping distance table, as described in claim 32.

Claim 32 additionally recites that:

if said windshield wiper sensor indicates that said windshield wiper is deactivated, said processor subsystem determining whether to activate said vehicle proximity alarm circuit based on data received from said radar detector, said road speed sensor and said first vehicle speed/stopping distance table stored in said memory subsystem;

and

if said windshield wiper sensor indicates that said windshield wiper is activated, said processor subsystem determining whether to activate said vehicle proximity alarm circuit based on data received from said radar detector, said road speed sensor and said second vehicle speed/stopping distance table stored in said memory subsystem.

According to the applicants, “[i]f the road is dry, the processor subsystem uses a first vehicle speed/stopping distance table to determine if an object is too closed to the vehicle” and “[i] the road is wet, however, the processor subsystem uses a second vehicle speed/stopping distance table to determine if the object is too close to the vehicle.” Referring, for example, to page 18, lines 19 to 26, Tonkin teaches the same control strategy:

[A] two level warning system can be provided wherein, a first warning, e.g. turn on all lamps 13, when a trailing vehicle 18 encroaches within the safe stopping distance of the subject vehicle 16 for poor weather conditions, and a second warning e.g. flash all or some lamps 13, if the trailing vehicle encroaches within the safe stopping distance for good conditions.

A person of ordinary skill in the art, at the time the alleged inventions of claim 18 of the '781 patent was made, would have found it obvious to combine the teachings of Davidian Chasteen, and Tonkin and, in addition, would have been motivated to do so, for example, to provide an “anti-collision system for vehicles” that “computes[] the danger-of-collision distance to the object” (Davidian, Col. 1, line 7 and col. 2, lines 3-4) and to “provide safety

information for example to drivers of following vehicles” (Tonkin, page 1, lines 4-5). The ’781 patent states that its object is to “provide a system which integrates the ability to issue audible warnings which advise the driver to correct operation of the vehicle in a manner which will enhance the efficient operation thereof with the ability to automatically take corrective action if the vehicle is being operated unsafely.” Col. 1, line 66 to col. 2, line 5. Thus, like the ’781 patent, Tonkin and Doi et al. are concerned with, for example, vehicle safety.

Moreover, the combination of these teachings is merely (a) the combination of prior art elements according to known methods to yield predictable results; (b) the simple substitution of known elements for one another to obtain predictable results; (c) the use of known techniques to improve similar devices in the same way; (d) the application of known techniques to known devices ready for improvement to yield predictable results; (e) obvious to try; and (f) known to work in one field of endeavor prompting variations for use in either the same field or a different one based on design incentives or other market forces since the variations are predictable to one of ordinary skill in the art.

As set forth in the appended charts, the combination of Davidian and Tonkin teaches all of the limitations of claim 32 of the ’781 patent and therefore renders obvious claim 32 of the ’781 patent. Therefore, VWGoA proposes a ground of rejection of claim 32 of the ’781 patent under 35 U.S.C. § 103(a) as obvious by the combination of Davidian and Tonkin.

### **VIII. VWGoA’s PROPOSED GROUNDS OF REJECTION**

In view of all of the foregoing, and the annexed claim charts, VWGoA respectfully proposes the following grounds of rejection:

1. Claim 1 is Obvious Under 35 U.S.C. § 103(a) in View of the Combination of Jurgen and Saturn ’452
2. Claims 1, 7, and 13 are Obvious Under 35 U.S.C. § 103(a) in View of the Combination of Jurgen and Toyota ’599
3. Claims 1, 7, and 13 are Obvious Under 35 U.S.C. § 103(a) in View of the Combination of Jurgen and Volkswagen ’070
4. Claims 17–23 and 26 are Obvious Under 35 U.S.C. § 103(a) in View of the Combination of Jurgen, Toyota ’599, and Davidian
5. Claims 17–23 and 26 are Obvious Under 35 U.S.C. § 103(a) in View of the Combination of Jurgen, Volkswagen ’070, and Davidian
6. Claims 17–21 and 23 are Obvious Under 35 U.S.C. § 103(a) in View of the Combination of Jurgen, Saturn ’452, and Davidian

7. Claims 28–30 are Obvious Under 35 U.S.C. § 103(a) in View of the Combination of Jurgen and Nissan '055
8. Claims 28–30 are Obvious Under 35 U.S.C. § 103(a) in View of the Combination of Jurgen and Mack '324
9. Claims 28–30 are Obvious Under 35 U.S.C. § 103(a) in View of the Combination of Jurgen and GM '753
10. Claim 31 is Anticipated Under 35 U.S.C. § 102(b) by Davidian
11. Claims 31 and 32 are Obvious Under 35 U.S.C. § 103(a) in View of the Combination of Tonkin and Doi et al.
12. Claims 2, 4, and 5 are Obvious Under 35 U.S.C. § 103(a) in View of the Combination of Jurgen, Saturn '452, and Chasteen
13. Claims 2, 4, 5, 8, 10, 12, and 15 are Obvious Under 35 U.S.C. § 103(a) in View of the Combination of Jurgen, Toyota '599, and Chasteen
14. Claims 2, 4, 5, 8, 10, 12, and 15 are Obvious Under 35 U.S.C. § 103(a) in View of the Combination of Jurgen, Volkswagen '070, and Chasteen
15. Claim 18 is Obvious Under 35 U.S.C. § 103(a) in View of the Combination of Jurgen, Toyota '599, Davidian, and Tonkin
16. Claim 18 is Obvious Under 35 U.S.C. § 103(a) in View of the Combination of Jurgen, Volkswagen '070, Davidian, and Tonkin
17. Claim 18 is Obvious Under 35 U.S.C. § 103(a) in View of the Combination of Jurgen, Saturn '452, Davidian, and Tonkin
18. Claims 24 and 25 are Obvious Under 35 U.S.C. § 103(a) in View of the Combination of Jurgen, Saturn '452, Davidian and Chasteen
19. Claims 24, 25, and 27 are Obvious Under 35 U.S.C. § 103(a) in View of the Combination of Jurgen, Toyota '599, Davidian and Chasteen
20. Claims 24, 25, and 27 are Obvious Under 35 U.S.C. § 103(a) in View of the Combination of Jurgen, Volkswagen '070, Davidian and Chasteen
21. Claim 32 is Obvious Under 35 U.S.C. § 103(a) in in View of the combination of Davidian and Tonkin

**IX. FEE PURSUANT TO 37 C.F.R. § 1.510(a)**

The fee under 37 C.F.R. § 1.510(a) for requesting *ex parte* reexamination is being paid by credit card. The Director is authorized to charge any additional fees that may be required in connection with this paper or these proceedings on behalf of Requester,

Volkswagen Group of America, Inc., to the deposit account of Kenyon & Kenyon LLP, Deposit Account 11-0600.

**X. CERTIFICATION PURSUANT TO 37 C.F.R. § 1.510(b)(5)**

According to 37 C.F.R. § 1.510(b)(5), a request for *ex parte* reexamination must include a certification that a copy of the request filed by a person other than the patent owner has been served in its entirety on the patent owner at the address as provided for in 37 C.F.R. § 1.33(c).

According to the Office's PAIR system, the correspondence address for the '781 patent is: Michael S. Bush, Haynes & Boone LLP, 3100 Nationsbank Plaza, 901 Main Street, Dallas, TX 75202-3789. Accordingly, a copy of this Request is being served in its entirety at the foregoing correspondence address as provided for in 37 C.F.R. § 1.33(c), in accordance with 37 C.F.R. § 1.510(b)(5). A certificate of service is annexed hereto as Exhibit 10, which sets forth that, pursuant to 37 C.F.R. § 1.510(b)(5), a copy of this Request is being served in its entirety on "the patent owner at the address as provided for in [37 C.F.R.] § 1.33(c)" at the following address: 3100 Nationsbank Plaza, 901 Main Street, Dallas, TX 75202-3789.

**XI. CERTIFICATION PURSUANT TO 37 C.F.R. § 1.510(b)(6)**

Requester Volkswagen Group of America, Inc. hereby certifies that the statutory estoppel provisions of 35 U.S.C. § 315(e)(1) or 35 U.S.C. § 325(e)(1) do not prohibit the filing of the *ex parte* reexamination request.



**XII. CONCLUSION**

For all of the reasons set forth above, reexamination of claims 1, 2, 4, 5, 7, 8, 10, 12, 13, 15, and 17–32 of the '781 patent is requested.

Respectfully submitted,

Date: May 22, 2014

By: /Clifford A. Ulrich/  
Clifford A. Ulrich  
Reg. No. 42,194

KENYON & KENYON LLP  
One Broadway  
New York, New York 10004  
(212) 425-7200 (telephone)  
(212) 425-5288 (facsimile)  
CUSTOMER NO. 26646

Attorneys for Requester,  
VOLKSWAGEN GROUP OF  
AMERICA, INC.

## Appendix

1.	Claim 1 is Obvious in View of the Combination of Jurgen and Saturn '452 .....	A-3
2.	Claims 1, 7, and 13 are Obvious in View of the Combination of Jurgen and Toyota '599 .....	A-9
3.	Claims 1, 7, and 13 are Obvious in View of the Combination of Jurgen and Volkswagen '070 .....	A-31
4.	Claims 17-23 and 26 are Obvious in View of the Combination of Jurgen, Toyota '599, and Davidian.....	A-57
5.	Claims 17-23 and 26 are Obvious in View of the Combination of Jurgen, Volkswagen '070, and Davidian.....	A-104
6.	Claims 17-21 and 23 are Obvious in View of the Combination of Jurgen, Saturn '452, and Davidian.....	A-153
7.	Claims 28-30 are Obvious in View of the Combination of Jurgen and Nissan '055 .....	A-185
8.	Claims 28-30 are Obvious in View of the Combination of Jurgen and Mack '324.....	A-200
9.	Claims 28-30 are Obvious in View of the Combination of Jurgen and GM '753.....	A-213
10.	Claim 31 is Anticipated by Davidian.....	A-225
11.	Claims 31 and 32 are Obvious in View of the Combination of Tonkin and Doi et al.....	A-230
12.	Claims 2, 4, and 5 are Obvious in View of the Combination of Jurgen, Saturn '452, and Chasteen.....	A-241
13.	Claims 2, 4, 5, 8, 10, 12, and 15 are Obvious in View of the Combination of Jurgen, Toyota '599, and Chasteen .....	A-257
14.	Claims 2, 4, 5, 8, 10, 12, and 15 are Obvious in View of the Combination of Jurgen, Volkswagen '070, and Chasteen.....	A-308
15.	Claim 18 is Obvious in View of the Combination of Jurgen, Toyota '599, Davidian, and Tonkin .....	A-349
16.	Claim 18 is Obvious in View of the Combination of Jurgen, Volkswagen '070, Davidian, and Tonkin .....	A-354
17.	Claim 18 is Obvious in View of the Combination of Jurgen, Saturn '452, Davidian, and Tonkin .....	A-359
18.	Claims 24 and 25 are Obvious in View of the Combination of Jurgen, Saturn '452, Davidian, and Chasteen.....	A-364

19.	Claims 24, 25, and 27 are Obvious in View of the Combination of Jurgen, Toyota '599, Davidian, and Chasteen.....	A-383
20.	Claims 24, 25, and 27 are Obvious in View of the Combination of Jurgen, Volkswagen '070, Davidian, and Chasteen .....	A-410
21.	Claim 32 is Obvious in View of the Combination of Davidian and Tonkin .....	A-433

1. Claim 1 is Obvious in View of the Combination of Jurgen and Saturn '452

Limitation of '781 Patent Claim 1	Automotive Electronics Handbook (Jurgen)	U.S. Patent No. 5,477,452 (Saturn '452)
<p>1. Apparatus for optimizing operation of a vehicle, comprising:</p>	<p>E.g., page 12.1, "The electronic engine control system consists of sensing devices which continuously measure the operating conditions of the engine, <i>an electronic control unit (ECU) which evaluates the sensor inputs using data tables and calculations and determines the output to the actuating devices</i>, and actuating devices which are commanded by the ECU to perform an action in response to the sensor inputs.</p> <p>The motive for using an electronic engine control system is to provide the needed accuracy and adaptability in order to minimize exhaust emissions and fuel consumption, <i>provide optimal driveability for all operating conditions</i>, minimize evaporative emissions, and provide system diagnosis when malfunctions occur."</p>	<p>E.g., Abstract, "<i>A motor vehicle has a manual transmission and means for indicating to the operator a point in operation for upshifting to the next higher gear from the present gear. A method of determining the shift point</i> is provided based upon actual operating parameters of the motor vehicle effecting current wheel torque and predicted wheel torque in the next higher gear."</p>
<p>a plurality of sensors coupled to a vehicle having an engine, said plurality of sensors, which collectively monitor operation of said vehicle, including a road speed sensor, an engine speed sensor, a manifold pressure sensor and a throttle position sensor;</p>	<p>E.g., page 7.6, "There are several applications for rotational speed sensing. <i>First it is necessary to monitor engine speed</i>. This information is used for transmission control, engine control, cruise control, and possibly for a tachometer. Electronics and electronic sensing in the automobile were brought about by the need for higher efficiency engines, better fuel economy, increased power and performance, and lower emissions. Second, <i>wheel speed sensing is required</i> for use in transmissions, cruise control, speedometers, antilock brake systems (ABS), traction control (ASR), variable ratio power steering assist, four-wheel steering, and possibly in inertial navigation and air bag deployment applications."</p> <p>E.g., page 7.8, "In electronic transmission applications, <i>information from the road and engine speed sensors</i>, as well as torque data and throttle position are required for the MCU to select the optimum gear ratio."</p> <p>E.g., page 2.5, "Automotive specification and testing guidelines have been developed and published by the Society of Automotive Engineers (SAE) specifically for <i>manifold absolute pressure (MAP) sensors</i>."</p>	<p>E.g., col. 1, lines 31 to 33, "Conventional shift indicator calibration typically involves setting <i>manifold pressure (MAP)</i> thresholds at a variety of speeds."</p> <p>E.g., col. 2, lines 13 to 18, "Referring to FIG. 1, the reference numeral 10 generally designates a motor vehicle drivetrain comprising a spark ignition <i>internal combustion engine (engine)</i> 12, engine output shaft 10 and the combination of conventional manual clutch, gearbox and final drive assembly (manual drivetrain) 16."</p> <p>E.g., col. 2, lines 42 to 44, "Control unit 42 receives inputs required by the present embodiment including <i>manifold absolute pressure (MAP)</i>, on line 46, <i>engine speed (Ne)</i> on line 50 and output speed (No) on line 54."</p> <p>E.g., col. 7, lines 13 to 21, "Throttle position "%T" is checked at block 515 against a closed position threshold K3. Closed throttle is indicative of vehicle coast, a state of operation wherein the engine is not imparting torque to the drive wheels and thus does not necessitate an upshift. Closed throttle may also be indicative of the operator purposefully using the drivetrain to decelerate the vehicle."</p>

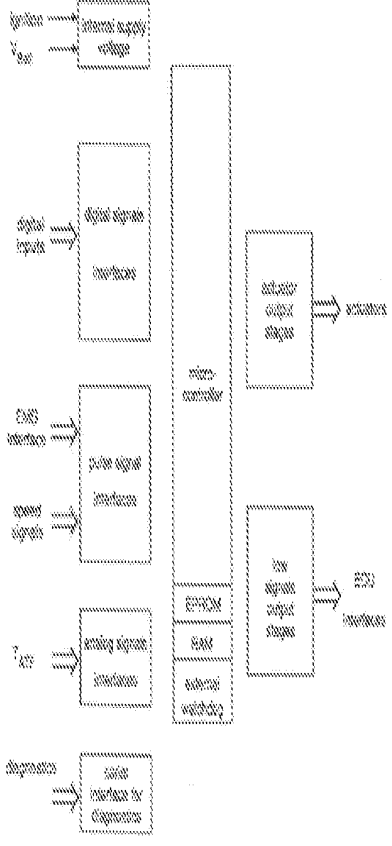
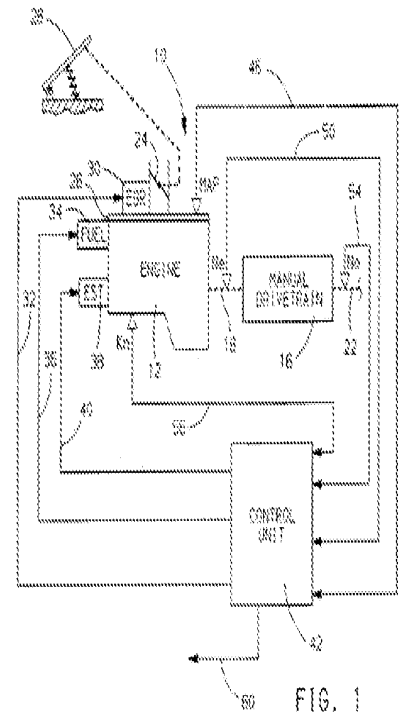

Limitation of '781 Patent Claim 1	Automotive Electronics Handbook (Jurgen)	U.S. Patent No. 5,477,452 (Saturn '452)
	 <p>FIGURE 3.1 Overview of hardware parts.</p> <p>E.g., page 14.3, “The speed sensor is one of the most critical parts in the system, because the <i>microcontroller calculates the vehicle speed from the speed sensor’s signal</i> to within 1/32 m/h.”</p>	 <p>FIG. 1</p>
<p>a memory subsystem, coupled to said processor subsystem, said memory subsystem storing therein a manifold pressure set point, an RPM set point, and present and prior levels for each one of said plurality of sensors;</p>	<p>E.g., page 13.5, “The calculators inside the control units are usually microcontrollers. . . . <i>The memory devices for program and data are usually EPROMS.</i> Their storage capacity is, in present applications, up to 64 Kbytes. Future applications will necessitate storage sizes up to 128 Kbytes. The failure storages for diagnostics and the storage for adaptive data are in conventional applications, battery voltage-supplied RAMs. These are increasingly being replaced by EEPROMs.”</p> <p>E.g., page 12.9, “A subsystem of the fuel control system is lambda</p>	<p>E.g., col. 2, lines 52 to 55, “Control unit 42 may be mechanized with a conventional state of the art microcomputer controller including a central processing unit, <i>memory</i> and input-output devices.”</p> <p>E.g., col. 6, lines 55 to 60, “First, <i>engine speed Ne is checked at block 511 to determine if it exceeds a predetermined maximum allowable engine speed threshold K1.</i> If the threshold is exceeded then an upshift is required regardless of the value of UTR and control is therefore passed via line 560 to block 542 where the shift</p>

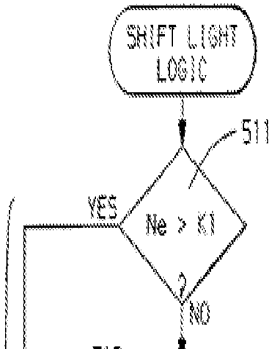
Limitation of '781 Patent Claim 1	Automotive Electronics Handbook (Jurgen)	U.S. Patent No. 5,477,452 (Saturn '452)
	<p>closed-loop control. . . .</p> <p>[T]he engine control unit uses an anticipatory control strategy that uses engine load and RPM to determine the approximate fuel requirement. <i>The engine load information is provided by the manifold pressure sensor for speed density systems and by the air meter for air flow and air mass measurement systems and by the throttle valve position sensor. The engine control unit contains data tables for combinations of load and RPM.</i> This allows for rapid response to changes in operating conditions. The lambda sensor still provides the feedback correction for each load/RPM point. . . .</p> <p>[T]he electronic control unit has a feature for adapting changes in the fuel required for the load/RPM points. <i>At each load/RPM point, the lambda sensor continuously provides information that allows the system to adjust the fuel to the commanded A/F ratio. The corrected information is stored in RAM (random access memory) so that the next time the engine reaches that operating point (load/RPM), the anticipatory value will require less correction. These values remain stored in the electronic control unit even after the engine is shut off.</i> Only if power to the electronic control unit is disrupted (i.e., due to a dead battery), will the correction be lost. In that case, the electronic control unit will revert back to the original production values that are written in ROM (read-only memory).”</p>	<p>light flag is set to one (SL FLAG=1). If the threshold at block 511 is not exceeded, decision block 512 is encountered.”</p> <p>E.g., FIG. 5:</p>  <pre> graph TD     A([SHIFT LIGHT LOGIC]) --&gt; B{511 Ne &gt; K1}     B -- YES --&gt; C[ ]     B -- NO --&gt; D[ ]     style C fill:none,stroke:none     style D fill:none,stroke:none   </pre>
<p>a fuel overinjection notification circuit coupled to said processor subsystem, said fuel overinjection notification circuit issuing a notification that excessive fuel is being supplied to said engine of said vehicle;</p>	<p>E.g., page 12.22, “During an acceleration transition, the ECU adds a correction factor (an increase) to the commanded injector pulse width. The sudden increase in air results in a lean mixture which must be corrected swiftly to obtain good transitional response. <i>During a deceleration transition, the fuel can be shut off by simply not providing a pulse width signal to the injector to minimize exhaust emissions and fuel consumption.</i>”</p> <p>E.g., page 12.4, “During coasting and braking, fuel consumption can be further reduced by shutting off the fuel until the engine speed decreases to slightly higher than the set idle speed. <i>The ECU determines when fuel shutoff can occur by evaluating the throttle</i></p>	

Limitation of '781 Patent Claim 1	Automotive Electronics Handbook (Jurgen)	U.S. Patent No. 5,477,452 (Saturn '452)
<p>an upshift notification circuit coupled to said processor subsystem, said upshift notification circuit issuing a notification that said engine of said vehicle is being operated at an excessive speed;</p>	<p><i>position, engine RPM, and vehicle speed.”</i></p> <p>E.g., page 13.7 to 13.9, “<i>The basic functions of the transmission control are the shift point control, the lockup control, engine torque control during shifting, related safety functions, and diagnostic functions for vehicle service.</i>”</p> <p>E.g., page 13.9, “The basic shift point control uses shift maps, which are defined in data in the unit memory. These shift maps are selectable over a wide range. <i>The shift point limitations are made, on the one hand, by the highest admissible engine speed for each application and, on the other hand, by the lowest engine speed that is practical for driving comfort and noise emission. The inputs of the shift point determination are the throttle position, the accelerator pedal position, and the vehicle speed</i> (determined by the transmission output speed).”</p> <p>E.g., page 13.14, “In addition to these functions, <i>different shift maps can be implemented into the data field of the TCU [Transmission Control Unit].</i> For example, it is possible to have one shift map for low fuel consumption, which has shift points in the range of the best efficiency of the engine, and additionally to have another map for power operation, where the shift points are placed at points of highest engine output power.”</p>	<p>E.g., Abstract, “<i>A motor vehicle has a manual transmission and means for indicating to the operator a point in operation for upshifting to the next higher gear from the present gear. A method of determining the shift point</i> is provided based upon actual operating parameters of the motor vehicle effecting current wheel torque and predicted wheel torque in the next higher gear.”</p> <p>E.g., col. 1, lines 10 to 13, “Shift indicators are commonly used on manual transmission vehicles <i>to assist non-expert drivers in determining when it is appropriate to shift the transmission to a higher gear</i> in order to maximize driving fuel economy.”</p> <p>E.g., col. 2, lines 42 to 55, “Control unit 42 receives inputs required by the present embodiment including manifold absolute pressure (MAP), on line 46, engine speed (Ne) on line 50 and output speed (No) on line 54. Knock sensing means Kn are also shown providing signal input via line 56 to control unit 42. <i>Control unit 42 indicates via line 60 the state of an upshift indicator light or equivalent visual display such as is found in conventional instrumentation in a motor vehicle. Line 60 may provide a logic signal to an instrument cluster for further processing or may drive a lamp directly via a power driver in control unit 42.</i> Control unit 42 may be mechanized with a conventional state of the art microcomputer controller including a central processing unit, memory and input-output devices.”</p> <p>E.g., col. 3, lines 60 to 65, “Finally, <i>control unit 42 outputs a signal online [sic] 60 as shown in FIG. 1 for indicating the state of the upshift indicator light</i> as well as various other output signals for instrument cluster displays such as vehicle speedometer, oil pressure and coolant temperature for example.”</p>
<p>said processor subsystem determining, based upon data received from said plurality of sensors, when to activate said fuel overinjection circuit and when to</p>	<p>E.g., page 12.4, “During coasting and braking, fuel consumption can be further reduced by shutting off the fuel until the engine speed decreases to slightly higher than the set idle speed. <i>The ECU determines when fuel shutoff can occur by evaluating the throttle position, engine RPM, and vehicle speed.</i>”</p>	<p>E.g., col. 2, lines 42 to 55, “Control unit 42 receives inputs required by the present embodiment including manifold absolute pressure (MAP), on line 46, engine speed (Ne) on line 50 and output speed (No) on line 54. Knock sensing means Kn are also shown providing signal input via line 56 to control unit 42. <i>Control unit</i></p>





**2. Claims 1, 7, and 13 are Obvious in View of the Combination of Jurgen and Toyota '599**

Limitation of '781 Patent Claim 1	Automotive Electronics Handbook (Jurgen)	U.S. Patent No. 4,559,599 (Toyota '599)
<p>1. Apparatus for optimizing operation of a vehicle, comprising:</p>	<p>E.g., page 12.1, "The electronic engine control system consists of sensing devices which continuously measure the operating conditions of the engine, <i>an electronic control unit (ECU) which evaluates the sensor inputs using data tables and calculations and determines the output to the actuating devices</i>, and actuating devices which are commanded by the ECU to perform an action in response to the sensor inputs.</p> <p>The motive for using an electronic engine control system is to provide the needed accuracy and adaptability in order to minimize exhaust emissions and fuel consumption, <i>provide optimal driveability for all operating conditions</i>, minimize evaporative emissions, and provide system diagnosis when malfunctions occur."</p>	<p>E.g., Abstract, "<i>A shift indication apparatus</i> having an engine rotation sensor, a throttle valve sensor, and a shift position sensor, a microcomputer having a ROM and RAM for storing data corresponding to the engine speed, throttle valve openings, and the shift positions therein, and an indicator for indicating preferable shift positions to be performed by a driver in which a torque data map and a fuel consumption rate data map have stored in the ROM for calculating various torque and fuel consumption rates <i>so as to obtain preferable shift positions relating to optimum fuel consumption rate in accordance with said data detected. With this construction, it becomes possible for a driver to run his car in accordance with the indications of the shift operation on the indicator so as to enable the economical running of the car to be realized.</i>"</p>
<p>a plurality of sensors coupled to a vehicle having an engine, said plurality of sensors, which collectively monitor operation of said vehicle, including a road speed sensor, an engine speed sensor, a manifold pressure sensor and a throttle position sensor;</p>	<p>E.g., page 7.6, "There are several applications for rotational speed sensing. <i>First it is necessary to monitor engine speed.</i> This information is used for transmission control, engine control, cruise control, and possibly for a tachometer. Electronics and electronic sensing in the automobile were brought about by the need for higher efficiency engines, better fuel economy, increased power and performance, and lower emissions. Second, <i>wheel speed sensing is required</i> for use in transmissions, cruise control, speedometers, antilock brake systems (ABS), traction control (ASR), variable ratio power steering assist, four-wheel steering, and possibly in inertial navigation and air bag deployment applications."</p> <p>E.g., page 7.8, "In electronic transmission applications, <i>information from the road and engine speed sensors</i>, as well as torque data and throttle position are required for the MCU to select the optimum gear ratio."</p> <p>E.g., page 2.5, "Automotive specification and testing guidelines have been developed and published by the Society of Automotive Engineers (SAE) specifically for <i>manifold absolute pressure (MAP) sensors.</i>"</p>	<p>E.g., col. 2, lines 23 to 36, "Referring to FIG. 1, the shift indication apparatus with a manual transmission according to the present invention comprises <i>an engine speed sensor 1 for detecting the engine speed and for producing pulse signals of a frequency proportional to the engine speed</i>, a shift position sensor 2 for detecting the shift positions of the transmission, <i>a throttle sensor 3 for detecting the opening degree of the throttle valve by means of, for instance, a potentiometer</i>, an A/D converter 4 for converting analog signals from the throttle valve sensor 3 into digital signals, a microcomputer 5 for performing various calculations in accordance with the different signals from the sensors, and an indicator 10 for indicating the result of the calculations."</p> <p>E.g., col. 2, lines 43 to 48, "<i>The engine speed sensor 1</i> is mounted in a distributor (not shown) and the output of the sensor is connected to the input of the I/O port 6 so as to transmit the output pulses to the microcomputer 5 through the I/O port 6 and to store the data corresponding to the engine speed into the RAM 9."</p> <p>E.g., col. 2, lines 52 to 59, "Similarly, the output of <i>the throttle sensor 3</i> is connected through the A/D converter 4 to the input of the I/O port 6 so as to transmit the output signals thereof to the</p>

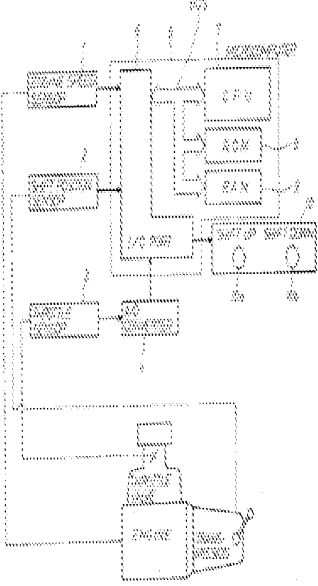
Limitation of '781 Patent Claim 1	Automotive Electronics Handbook (Jurgen)	U.S. Patent No. 4,559,599 (Toyota '599)
	<p>E.g., page 2.7, "Manifold absolute pressure (MAP) is used as an input to fuel and ignition control in internal combustion engine control systems. <i>The speed-density system that uses the MAP sensor</i> has been preferred over mass air flow (MAF) control because it's less expensive, but stricter emission standards are causing more manufacturers to use mass air flow for future models."</p> <p>E.g., page 12.18, "To control the idle speed, the ECU uses inputs from the <i>throttle position sensor</i>, air conditioning, automatic transmission, power steering, charging system, engine RPM, and vehicle speed."</p> <p>E.g., page 12.21, "The electronic injection unit also houses the <i>throttle position sensor</i> and, in some cases, an inlet air temperature sensor which provides operating condition information to the ECU."</p>	<p>microcomputer 5 through the A/D converter 4 and to store the data corresponding to the throttle value opening into the RAM 9 after converting from the analog signals into the digital signals."</p> <p>E.g., FIG. 1:</p> 
<p>a processor subsystem, coupled to each one of said plurality of sensors, to receive data therefrom;</p>	<p>E.g., page 12.1, "The electronic engine control system consists of <i>sensing devices which continuously measure the operating conditions of the engine, an electronic control unit (ECU) which evaluates the sensor inputs</i> using data tables and calculations and determines the output to the actuating devices, and actuating devices which are commanded by the ECU to perform an action in response to the sensor inputs."</p> <p>E.g., page 22.6, "During the entire operating time of the vehicle, <i>the ECUs are constantly supervising the sensors they are connected to.</i>"</p> <p>E.g., page 13.4, "On the functional side, the hardware configuration can be divided into power supply, input signal transfer circuits, output stages, and <i>microcontroller</i>, including peripheral components and monitoring and safety circuits (Fig. 13.1)."</p>	<p>E.g., col. 2, lines 23 to 36, "Referring to FIG. 1, the shift indication apparatus with a manual transmission according to the present invention comprises an engine speed sensor 1 for detecting the engine speed and for producing pulse signals of a frequency proportional to the engine speed, a shift position sensor 2 for detecting the shift positions of the transmission, a throttle sensor 3 for detecting the opening degree of the throttle valve by means of, for instance, a potentiometer, an A/D converter 4 for converting analog signals from the throttle valve sensor 3 into digital signals, <i>a microcomputer 5 for performing various calculations in accordance with the different signals from the sensors</i>, and an indicator 10 for indicating the result of the calculations."</p> <p>E.g., col. 2, lines 37 to 42, "<i>The microcomputer 5</i> further comprises an input/output port (I/O port) 6, <i>a central processing unit (CPU) 7</i>, a read only memory (ROM) 8, and a random access</p>

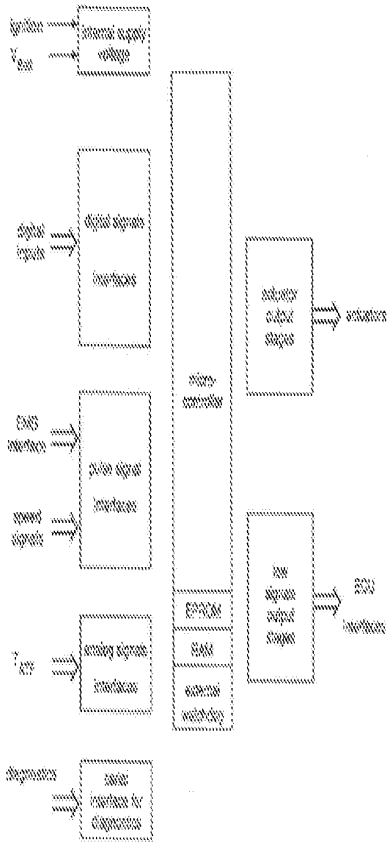
Limitation of '781 Patent Claim 1	Automotive Electronics Handbook (Jurgen)	U.S. Patent No. 4,559,599 (Toyota '599)
	<p>E.g., Figure 13.1:</p>  <p>FIGURE 13.1 Overview of hardware parts.</p> <p>E.g., page 14.3, “The speed sensor is one of the most critical parts in the system, because the <i>microcontroller calculates the vehicle speed from the speed sensor’s signal</i> to within 1/32 m/h.”</p>	<p>memory (RAM) 9. In the microcomputer 5, there is provided a bus BUS which communicates the I/O port 6 and the CPU 7, ROM 8, and RAM 9.”</p> <p>E.g., col. 2, lines 43 to 48, “The engine speed sensor 1 is mounted in a distributor (not shown) and <i>the output of the sensor is connected to the input of the I/O port 6 so as to transmit the output pulses to the microcomputer 5</i> through the I/O port 6 and to store the data corresponding to the engine speed into the RAM 9.”</p> <p>E.g., col. 2, lines 52 to 59, “Similarly, <i>the output of the throttle sensor 3 is connected through the A/D converter 4 to the input of the I/O port 6 so as to transmit the output signals thereof to the microcomputer 5</i> through the A/D converter 4 and to store the data corresponding to the throttle value opening into the RAM 9 after converting from the analog signals into the digital signals.”</p>
<p>a memory subsystem, coupled to said processor subsystem, said memory subsystem storing therein a manifold pressure set point, an RPM set point, and present and prior levels for each one of said plurality of sensors;</p>	<p>E.g., page 13.5, “The calculators inside the control units are usually microcontrollers. . . . <i>The memory devices for program and data are usually EPROMS.</i> Their storage capacity is, in present applications, up to 64 Kbytes. Future applications will necessitate storage sizes up to 128 Kbytes. The failure storages for diagnostics and the storage for adaptive data are in conventional applications, battery voltage-supplied RAMs. These are increasingly being</p>	<p>E.g., col. 2, lines 37 to 42, “The microcomputer 5 further comprises an input/output port (I/O port) 6, a central processing unit (CPU) 7, <i>a read only memory (ROM) 8, and a random access memory (RAM) 9.</i> In the microcomputer 5, there is provided a bus BUS which communicates the I/O port 6 and the CPU 7, <i>ROM 8, and RAM 9.</i>”</p>

Limitation of '781 Patent Claim 1	Automotive Electronics Handbook (Jurgen)	U.S. Patent No. 4,559,599 (Toyota '599)
	<p>replaced by EEPROMs.”</p> <p>E.g., page 12.9, “A subsystem of the fuel control system is lambda closed-loop control. . . .</p> <p>[T]he engine control unit uses an anticipatory control strategy that uses engine load and RPM to determine the approximate fuel requirement. <i>The engine load information is provided by the manifold pressure sensor for speed density systems and by the air meter for air flow and air mass measurement systems and by the throttle valve position sensor. The engine control unit contains data tables for combinations of load and RPM.</i> This allows for rapid response to changes in operating conditions. The lambda sensor still provides the feedback correction for each load/RPM point. . . .</p> <p>[T]he electronic control unit has a feature for adapting changes in the fuel required for the load/RPM points. <i>At each load/RPM point, the lambda sensor continuously provides information that allows the system to adjust the fuel to the commanded A/F ratio. The corrected information is stored in RAM (random access memory) so that the next time the engine reaches that operating point (load/RPM), the anticipatory value will require less correction. These values remain stored in the electronic control unit even after the engine is shut off.</i> Only if power to the electronic control unit is disrupted (i.e., due to a dead battery), will the correction be lost. In that case, the electronic control unit will revert back to the original production values that are written in ROM (read-only memory).”</p> <p>E.g., page 14.2, “Other safety-related items include <i>program code to detect abnormal operating conditions and preserving into memory the data points associated with the abnormal condition for later diagnostics.</i> Abnormal conditions, for example, could be an intermittent vehicle speed sensor, or erratic driver switch signals.”</p> <p>E.g., pages 22.2 to 22.3, “The most important test points of control units and sensors are tied to a diagnostic connector which is</p>	<p>E.g., col. 3, lines 7 to 20, “<i>The torque data map indicative of torque curves T as shown in FIG. 2 has been stored in the ROM 8 in advance. The fuel consumption rate data map indicative of equal fuel consumption rate curves B as shown in FIG. 3 has been also stored in the ROM 8 in advance. In FIG. 2, each equal torque curve T was prepared by plotting and connecting equal torque points on the graph with respect to the engine speed vs. throttle valve opening.</i> In FIG. 3, each fuel consumption rate curve B was prepared by plotting and connecting equal fuel consumption rate points on a graph obtained in advance by experiment data with respect to the engine speed and the torques thus calculated.”</p> <p>E.g., col. 3, lines 44 to 61, “<i>In this case, as shown in FIG. 4, the operation of a main routine is started at a predetermined timing, e.g. periodical timing pulses from a timer (not shown) and the detection of the engine speed <math>N_e</math> from the sensor 1 is carried out and it is stored into the RAM 9 at the step 20. Then, the engine speed <math>N_e</math> is read from the RAM 9 and it is compared with a predetermined number N (=1000 rpm) to determine whether or not the <math>N_e</math> exceeds the value 1000 at the step 21.</i> If the result of the decision is YES, the next step 22 is executed. That is, in the step 22, the reading in of the opening of the throttle valve is performed through the throttle sensor 3 and the A/D converter 4. In the above case, if the result of the decision in step 21 is NO, the main routine is terminated by determining that the shift operation is not necessary and the engine speed <math>N_e</math> is read again at the predetermined timing and now the operation returns to the step 20.”</p> <p>E.g., Figure 4:</p>

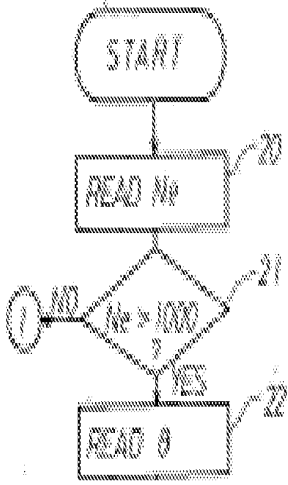
Limitation of '781 Patent Claim 1	Automotive Electronics Handbook (Jurgen)	U.S. Patent No. 4,559,599 (Toyota '599)
	<p>plugged into the measuring instrument with a corresponding adapter for the respective vehicle. . . .</p> <p><i>Modern electronics in vehicles support diagnosis by comparing the registered actual value with the internally stored nominal values with the help of control units and their self-diagnosis, thus detecting faults.</i>"</p>	 <pre> graph TD     START([START]) --&gt; READ_Nn[READ Nn]     READ_Nn --&gt; DEC{Nn &gt; 1000?}     DEC -- NO --&gt; END(( ))     DEC -- YES --&gt; READ_0[READ 0]   </pre>
<p>a fuel overinjection notification circuit coupled to said processor subsystem, said fuel overinjection notification circuit issuing a notification that excessive fuel is being supplied to said engine of said vehicle;</p>	<p>E.g., page 12.22, "During an acceleration transition, the ECU adds a correction factor (an increase) to the commanded injector pulse width. The sudden increase in air results in a lean mixture which must be corrected swiftly to obtain good transitional response. <i>During a deceleration transition, the fuel can be shut off by simply not providing a pulse width signal to the injector to minimize exhaust emissions and fuel consumption.</i>"</p> <p>E.g., page 12.4, "During coasting and braking, fuel consumption can be further reduced by shutting off the fuel until the engine speed decreases to slightly higher than the set idle speed. <i>The ECU determines when fuel shutoff can occur by evaluating the throttle position, engine RPM, and vehicle speed.</i>"</p> <p>E.g., page 12.14, "Using the inputs of engine RPM and vehicle speed to the electronic control unit, thresholds can be established for limiting these variables with fuel cutoff. <i>When the maximum speed is achieved, the fuel injectors are shut off.</i> When the speed decreases below the threshold, fuel injection resumes."</p> <p>E.g., page 12.17, "<i>During transition to fuel cutoff, the ignition timing is retarded from its current setting to reduce engine torque</i>"</p>	

Limitation of '781 Patent Claim 1	Automotive Electronics Handbook (Jurgen)	U.S. Patent No. 4,559,599 (Toyota '599)
	<p><i>and to assist in engine braking. The fuel is then shut off.</i> During the transition, the throttle bypass valve or the main throttle valve may remain open for a short period to allow fresh air to oxidize the remaining unburned HC and CO to further reduce exhaust emissions. During development of the fuel cutoff strategy, the advantage of reduced emission effects and catalyst temperature control must be balanced against driveability requirements. The use of fuel cutoff may change the perceived amount of engine braking felt by the driver. In addition, care must be taken to avoid a 'bump' feel when entering the fuel cutoff mode, due to the change in torque."</p>	
<p>an upshift notification circuit coupled to said processor subsystem, said upshift notification circuit issuing a notification that said engine of said vehicle is being operated at an excessive speed;</p>	<p>E.g., page 13.7 to 13.9, "<i>The basic functions of the transmission control are the shift point control, the lockup control, engine torque control during shifting, related safety functions, and diagnostic functions for vehicle service.</i>"</p> <p>E.g., page 13.9, "The basic shift point control uses shift maps, which are defined in data in the unit memory. These shift maps are selectable over a wide range. <i>The shift point limitations are made, on the one hand, by the highest admissible engine speed for each application and, on the other hand, by the lowest engine speed that is practical for driving comfort and noise emission. The inputs of the shift point determination are the throttle position, the accelerator pedal position, and the vehicle speed</i> (determined by the transmission output speed)."</p> <p>E.g., page 13.14, "In addition to these functions, <i>different shift maps can be implemented into the data field of the TCU [Transmission Control Unit].</i> For example, it is possible to have one shift map for low fuel consumption, which has shift points in the range of the best efficiency of the engine, and additionally to have another map for power operation, where the shift points are placed at points of highest engine output power."</p>	<p>E.g., col. 2, line 64 to col. 3, line 3, "<i>The indicator 10 includes a shift-up indicating lamp 10a and a shift-down indicating lamp 10b.</i></p> <p><i>The indicator 10 may be assembled by light emitting [sic] diodes (LED) so as to perform shift-up and shift-down indications by up and down directed arrow marks.</i> Alternatively, the indicator 10 may also be replaced with other voice combining circuit so as to announce the shift operations by voice instead of the indications."</p> <p>E.g., col. 5, line 63 to col. 6, line 2, "Namely, in this step, the speed change operation indicating signal is applied to the indicator or display 10 from the microcomputer 5 through the I/O port 6. As a result, a particular lamp in this case, <i>a shift up indicating lamp in the indicator 10, is illuminated, thus indicating to the driver that the speed change from current shift position to the one step shifting up position SP<sub>+1</sub> is preferable.</i>"</p> <p>E.g. col. 7, lines 29 to 38, "However, <i>only when either one of the assumed fuel consumption rates above is better than the current fuel consumption rate B<sub>n</sub>, the corresponding shift-up lamp or shift-down lamp in the indicator 10 is illuminated,</i> thus indicating the necessity of the speed change operation."</p>
<p>said processor subsystem determining, based upon data received from said plurality of</p>	<p>E.g., page 12.4, "During coasting and braking, fuel consumption can be further reduced by shutting off the fuel until the engine speed decreases to slightly higher than the set idle speed. <i>The ECU</i></p>	<p>E.g., col. 2, lines 37 to 42, "<i>The microcomputer 5 further comprises an input/output port (I/O port) 6, a central processing unit (CPU) 7, a read only memory (ROM) 8, and a random access</i></p>

Limitation of '781 Patent Claim 1	Automotive Electronics Handbook (Jurgen)	U.S. Patent No. 4,559,599 (Toyota '599)
<p>sensors, when to activate said fuel overinjection circuit and when to activate said upshift notification circuit.</p>	<p><i>determines when fuel shutoff can occur by evaluating the throttle position, engine RPM, and vehicle speed.</i></p> <p>E.g., page 12.14, "Using the inputs of engine RPM and vehicle speed to the electronic control unit, thresholds can be established for limiting these variables with fuel cutoff. <i>When the maximum speed is achieved, the fuel injectors are shut off.</i> When the speed decreases below the threshold, fuel injection resumes."</p> <p>E.g., page 13.7 to 13.9, "<i>The basic functions of the transmission control are the shift point control, the lockup control, engine torque control during shifting, related safety functions, and diagnostic functions for vehicle service.</i>"</p> <p>E.g., page 13.9, "The basic shift point control uses shift maps, which are defined in data in the unit memory. These shift maps are selectable over a wide range. <i>The shift point limitations are made, on the one hand, by the highest admissible engine speed for each application and, on the other hand, by the lowest engine speed that is practical for driving comfort and noise emission. The inputs of the shift point determination are the throttle position, the accelerator pedal position, and the vehicle speed (determined by the transmission output speed).</i>"</p>	<p><i>memory (RAM) 9.</i> In the microcomputer 5, there is provided a bus BUS which communicates the I/O port 6 and the CPU 7, ROM 8, and RAM 9."</p> <p>E.g., col. 2, lines 59 to 63, "<i>The input of the indicator 10 is connected to the output of the I/O port 6 so as to indicate each preferable shift position corresponding to the optimum fuel consumption rate in accordance with various parameters calculated.</i>"</p> <p>E.g., col. 5, line 63 to col. 6, line 2, "<i>Namely, in this step, the speed change operation indicating signal is applied to the indicator or display 10 from the microcomputer 5 through the I/O port 6. As a result, a particular lamp in this case, a shift up indicating lamp in the indicator 10, is illuminated, thus indicating to the driver that the speed change from current shift position to the one step shifting up position SP<sub>+1</sub> is preferable.</i>"</p>

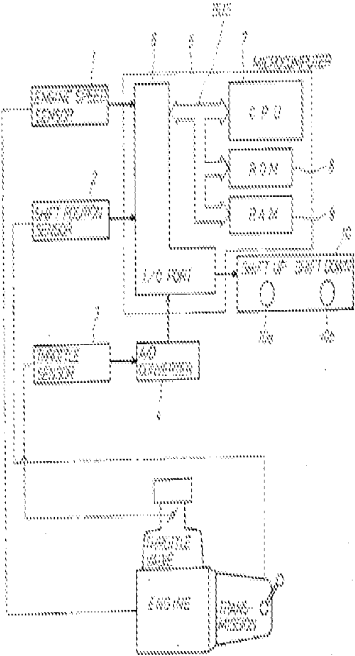

Limitation of '781 Patent Claim 7	Automotive Electronics Handbook (Jurgen)	U.S. Patent No. 4,559,599 (Toyota '599)
<p>7. Apparatus for optimizing operation of a vehicle, comprising:</p>	<p>E.g., page 12.1, "The electronic engine control system consists of sensing devices which continuously measure the operating conditions of the engine, <i>an electronic control unit (ECU) which evaluates the sensor inputs using data tables and calculations and determines the output to the actuating devices</i>, and actuating devices which are commanded by the ECU to perform an action in response to the sensor inputs.</p> <p>The motive for using an electronic engine control system is to provide the needed accuracy and adaptability in order to minimize exhaust emissions and fuel consumption, <i>provide optimal driveability for all operating conditions</i>, minimize evaporative emissions, and provide system diagnosis when malfunctions occur."</p>	<p>E.g., Abstract, "<i>A shift indication apparatus</i> having an engine rotation sensor, a throttle valve sensor, and a shift position sensor, a microcomputer having a ROM and RAM for storing data corresponding to the engine speed, throttle valve openings, and the shift positions therein, and an indicator for indicating preferable shift positions to be performed by a driver in which a torque data map and a fuel consumption rate data map have stored in the ROM for calculating various torque and fuel consumption rates <i>so as to obtain preferable shift positions relating to optimum fuel consumption rate in accordance with said data detected. With this construction, it becomes possible for a driver to run his car in accordance with the indications of the shift operation on the indicator so as to enable the economical running of the car to be realized.</i>"</p>
<p>a plurality of sensors coupled to a vehicle having an engine, said plurality of sensors, which collectively monitor operation of said vehicle, including a road speed sensor, a manifold pressure sensor and a throttle position sensor;</p>	<p>E.g., page 7.6, "There are several applications for rotational speed sensing. <i>First it is necessary to monitor engine speed.</i> This information is used for transmission control, engine control, cruise control, and possibly for a tachometer. Electronics and electronic sensing in the automobile were brought about by the need for higher efficiency engines, better fuel economy, increased power and performance, and lower emissions. Second, <i>wheel speed sensing is required</i> for use in transmissions, cruise control, speedometers, antilock brake systems (ABS), traction control (ASR), variable ratio power steering assist, four-wheel steering, and possibly in inertial navigation and air bag deployment applications."</p> <p>E.g., page 7.8, "In electronic transmission applications, <i>information from the road and engine speed sensors</i>, as well as torque data and throttle position are required for the MCU to select the optimum gear ratio."</p> <p>E.g., page 2.5, "Automotive specification and testing guidelines have been developed and published by the Society of Automotive Engineers (SAE) specifically for <i>manifold absolute pressure (MAP) sensors.</i>"</p> <p>E.g., page 2.7, "Manifold absolute pressure (MAP) is used as an</p>	<p>E.g., col. 2, lines 23 to 36, "Referring to FIG. 1, the shift indication apparatus with a manual transmission according to the present invention comprises <i>an engine speed sensor 1 for detecting the engine speed and for producing pulse signals of a frequency proportional to the engine speed</i>, a shift position sensor 2 for detecting the shift positions of the transmission, <i>a throttle sensor 3 for detecting the opening degree of the throttle valve by means of, for instance, a potentiometer</i>, an A/D converter 4 for converting analog signals from the throttle valve sensor 3 into digital signals, a microcomputer 5 for performing various calculations in accordance with the different signals from the sensors, and an indicator 10 for indicating the result of the calculations."</p> <p>E.g., col. 2, lines 43 to 48, "<i>The engine speed sensor 1</i> is mounted in a distributor (not shown) and the output of the sensor is connected to the input of the I/O port 6 so as to transmit the output pulses to the microcomputer 5 through the I/O port 6 and to store the data corresponding to the engine speed into the RAM 9."</p> <p>E.g., col. 2, lines 52 to 59, "Similarly, the output of <i>the throttle sensor 3</i> is connected through the A/D converter 4 to the input of the I/O port 6 so as to transmit the output signals thereof to the microcomputer 5 through the A/D converter 4 and to store the data corresponding to the throttle value opening into the RAM 9 after</p>

Limitation of '781 Patent Claim 7	Automotive Electronics Handbook (Jurgen)	U.S. Patent No. 4,559,599 (Toyota '599)
	<p>input to fuel and ignition control in internal combustion engine control systems. <i>The speed-density system that uses the MAP sensor</i> has been preferred over mass air flow (MAF) control because it's less expensive, but stricter emission standards are causing more manufacturers to use mass air flow for future models.”</p> <p>E.g., page 12.18, “To control the idle speed, the ECU uses inputs from the <i>throttle position sensor</i>, air conditioning, automatic transmission, power steering, charging system, engine RPM, and vehicle speed.”</p> <p>E.g., page 12.21, “The electronic injection unit also houses the <i>throttle position sensor</i> and, in some cases, an inlet air temperature sensor which provides operating condition information to the ECU.”</p>	<p>converting from the analog signals into the digital signals.”</p> <p>E.g., FIG. 1:</p> 
<p>a processor subsystem, coupled to each one of said plurality of sensors, to receive data therefrom;</p>	<p>E.g., page 12.1, “The electronic engine control system consists of <i>sensing devices which continuously measure the operating conditions of the engine, an electronic control unit (ECU) which evaluates the sensor inputs</i> using data tables and calculations and determines the output to the actuating devices, and actuating devices which are commanded by the ECU to perform an action in response to the sensor inputs.”</p> <p>E.g., page 22.6, “During the entire operating time of the vehicle, <i>the ECUs are constantly supervising the sensors they are connected to.</i>”</p> <p>E.g., page 13.4, “On the functional side, the hardware configuration can be divided into power supply, input signal transfer circuits, output stages, and <i>microcontroller</i>, including peripheral components and monitoring and safety circuits (Fig. 13.1).”</p>	<p>E.g., col. 2, lines 23 to 36, “Referring to FIG. 1, the shift indication apparatus with a manual transmission according to the present invention comprises an engine speed sensor 1 for detecting the engine speed and for producing pulse signals of a frequency proportional to the engine speed, a shift position sensor 2 for detecting the shift positions of the transmission, a throttle sensor 3 for detecting the opening degree of the throttle valve by means of, for instance, a potentiometer, an A/D converter 4 for converting analog signals from the throttle valve sensor 3 into digital signals, <i>a microcomputer 5 for performing various calculations in accordance with the different signals from the sensors</i>, and an indicator 10 for indicating the result of the calculations.”</p> <p>E.g., col. 2, lines 37 to 42, “<i>The microcomputer 5</i> further comprises an input/output port (I/O port) 6, <i>a central processing unit (CPU) 7</i>, a read only memory (ROM) 8, and a random access</p>

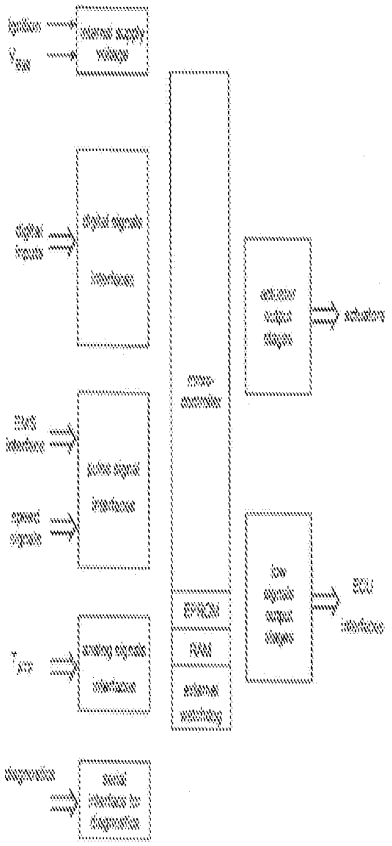
Limitation of '781 Patent Claim 7	Automotive Electronics Handbook (Jurgen)	U.S. Patent No. 4,559,599 (Toyota '599)
	<p>E.g., Figure 13.1:</p>  <p>FIGURE 13.1 Overview of hardware parts</p> <p>E.g., page 14.3, “The speed sensor is one of the most critical parts in the system, because the <i>microcontroller calculates the vehicle speed from the speed sensor’s signal</i> to within 1/32 m/h.”</p>	<p>memory (RAM) 9. In the microcomputer 5, there is provided a bus BUS which communicates the I/O port 6 and the CPU 7, ROM 8, and RAM 9.”</p> <p>E.g., col. 2, lines 43 to 48, “The engine speed sensor 1 is mounted in a distributor (not shown) and <i>the output of the sensor is connected to the input of the I/O port 6 so as to transmit the output pulses to the microcomputer 5</i> through the I/O port 6 and to store the data corresponding to the engine speed into the RAM 9.”</p> <p>E.g., col. 2, lines 52 to 59, “Similarly, <i>the output of the throttle sensor 3 is connected through the A/D converter 4 to the input of the I/O port 6 so as to transmit the output signals thereof to the microcomputer 5</i> through the A/D converter 4 and to store the data corresponding to the throttle value opening into the RAM 9 after converting from the analog signals into the digital signals.”</p>
<p>a memory subsystem, coupled to said processor subsystem, said memory subsystem storing therein a manifold pressure set point and present and prior levels for each one of said plurality of sensors;</p>	<p>E.g., page 13.5, “The calculators inside the control units are usually microcontrollers. . . . <i>The memory devices for program and data are usually EPROMS.</i> Their storage capacity is, in present applications, up to 64 Kbytes. Future applications will necessitate storage sizes up to 128 Kbytes. The failure storages for diagnostics and the storage for adaptive data are in conventional applications, battery voltage-supplied RAMs. These are increasingly being</p>	<p>E.g., col. 2, lines 37 to 42, “The microcomputer 5 further comprises an input/output port (I/O port) 6, a central processing unit (CPU) 7, <i>a read only memory (ROM) 8, and a random access memory (RAM) 9.</i> In the microcomputer 5, there is provided a bus BUS which communicates the I/O port 6 and the CPU 7, <i>ROM 8, and RAM 9.</i>”</p>

Limitation of '781 Patent Claim 7	Automotive Electronics Handbook (Jurgen)	U.S. Patent No. 4,559,599 (Toyota '599)
	<p>replaced by EEPROMs.”</p> <p>E.g., page 12.9, “A subsystem of the fuel control system is lambda closed-loop control. . . .</p> <p>[T]he engine control unit uses an anticipatory control strategy that uses engine load and RPM to determine the approximate fuel requirement. <i>The engine load information is provided by the manifold pressure sensor for speed density systems and by the air meter for air flow and air mass measurement systems and by the throttle valve position sensor. The engine control unit contains data tables for combinations of load and RPM.</i> This allows for rapid response to changes in operating conditions. The lambda sensor still provides the feedback correction for each load/RPM point. . . .</p> <p>[T]he electronic control unit has a feature for adapting changes in the fuel required for the load/RPM points. <i>At each load/RPM point, the lambda sensor continuously provides information that allows the system to adjust the fuel to the commanded A/F ratio. The corrected information is stored in RAM (random access memory) so that the next time the engine reaches that operating point (load/RPM), the anticipatory value will require less correction. These values remain stored in the electronic control unit even after the engine is shut off.</i> Only if power to the electronic control unit is disrupted (i.e., due to a dead battery), will the correction be lost. In that case, the electronic control unit will revert back to the original production values that are written in ROM (read-only memory).”</p> <p>E.g., page 14.2, “Other safety-related items include <i>program code to detect abnormal operating conditions and preserving into memory the data points associated with the abnormal condition for later diagnostics.</i> Abnormal conditions, for example, could be an intermittent vehicle speed sensor, or erratic driver switch signals.”</p> <p>E.g., pages 22.2 to 22.3, “The most important test points of control units and sensors are tied to a diagnostic connector which is</p>	<p>E.g., col. 3, lines 7 to 20, “<i>The torque data map indicative of torque curves T as shown in FIG. 2 has been stored in the ROM 8 in advance. The fuel consumption rate data map indicative of equal fuel consumption rate curves B as shown in FIG. 3 has been also stored in the ROM 8 in advance. In FIG. 2, each equal torque curve T was prepared by plotting and connecting equal torque points on the graph with respect to the engine speed vs. throttle valve opening.</i> In FIG. 3, each fuel consumption rate curve B was prepared by plotting and connecting equal fuel consumption rate points on a graph obtained in advance by experiment data with respect to the engine speed and the torques thus calculated.”</p> <p>E.g., col. 3, lines 44 to 61, “<i>In this case, as shown in FIG. 4, the operation of a main routine is started at a predetermined timing, e.g. periodical timing pulses from a timer (not shown) and the detection of the engine speed <math>N_e</math> from the sensor 1 is carried out and it is stored into the RAM 9 at the step 20. Then, the engine speed <math>N_e</math> is read from the RAM 9 and it is compared with a predetermined number <math>N (=1000 \text{ rpm})</math> to determine whether or not the <math>N_e</math> exceeds the value 1000 at the step 21.</i> If the result of the decision is YES, the next step 22 is executed. That is, in the step 22, the reading in of the opening of the throttle valve is performed through the throttle sensor 3 and the A/D converter 4. In the above case, if the result of the decision in step 21 is NO, the main routine is terminated by determining that the shift operation is not necessary and the engine speed <math>N_e</math> is read again at the predetermined timing and now the operation returns to the step 20.”</p> <p>E.g., Figure 4:</p>

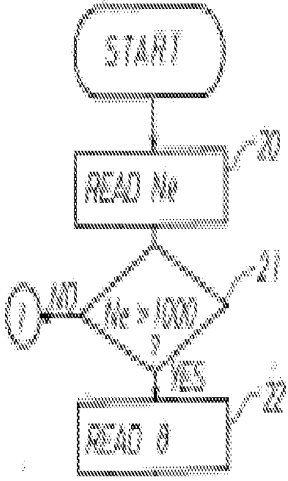
Limitation of '781 Patent Claim 7	Automotive Electronics Handbook (Jurgen)	U.S. Patent No. 4,559,599 (Toyota '599)
	<p>plugged into the measuring instrument with a corresponding adapter for the respective vehicle. . . .</p> <p><i>Modern electronics in vehicles support diagnosis by comparing the registered actual value with the internally stored nominal values with the help of control units and their self-diagnosis, thus detecting faults.</i></p>	 <pre> graph TD     START([START]) --&gt; READ_Ne[READ Ne 20]     READ_Ne --&gt; DEC{Ne &gt; 1000? 21}     DEC -- YES --&gt; READ_0[READ 0 22]   </pre>
<p>a fuel overinjection notification circuit coupled to said processor subsystem, said fuel overinjection notification circuit issuing a notification that excessive fuel is being supplied to said engine of said vehicle;</p>	<p>E.g., page 12.22, “During an acceleration transition, the ECU adds a correction factor (an increase) to the commanded injector pulse width. The sudden increase in air results in a lean mixture which must be corrected swiftly to obtain good transitional response. <i>During a deceleration transition, the fuel can be shut off by simply not providing a pulse width signal to the injector to minimize exhaust emissions and fuel consumption.</i>”</p> <p>E.g., page 12.4, “During coasting and braking, fuel consumption can be further reduced by shutting off the fuel until the engine speed decreases to slightly higher than the set idle speed. <i>The ECU determines when fuel shutoff can occur by evaluating the throttle position, engine RPM, and vehicle speed.</i>”</p> <p>E.g., page 12.14, “Using the inputs of engine RPM and vehicle speed to the electronic control unit, thresholds can be established for limiting these variables with fuel cutoff. <i>When the maximum speed is achieved, the fuel injectors are shut off.</i> When the speed decreases below the threshold, fuel injection resumes.”</p> <p>E.g., page 12.17, “<i>During transition to fuel cutoff, the ignition timing is retarded from its current setting to reduce engine torque</i>”</p>	

Limitation of '781 Patent Claim 7	Automotive Electronics Handbook (Jurgen)	U.S. Patent No. 4,559,599 (Toyota '599)
	<p><i>and to assist in engine braking. The fuel is then shut off.</i> During the transition, the throttle bypass valve or the main throttle valve may remain open for a short period to allow fresh air to oxidize the remaining unburned HC and CO to further reduce exhaust emissions. During development of the fuel cutoff strategy, the advantage of reduced emission effects and catalyst temperature control must be balanced against driveability requirements. The use of fuel cutoff may change the perceived amount of engine braking felt by the driver. In addition, care must be taken to avoid a 'bump' feel when entering the fuel cutoff mode, due to the change in torque."</p>	
<p>a downshift notification circuit coupled to said processor subsystem, said downshift notification circuit issuing a notification that said engine of said vehicle is being operated at an insufficient engine speed; and</p>	<p>E.g., page 13.7 to 13.9, "<i>The basic functions of the transmission control are the shift point control, the lockup control, engine torque control during shifting, related safety functions, and diagnostic functions for vehicle service.</i>"</p> <p>E.g., page 13.9, "The basic shift point control uses shift maps, which are defined in data in the unit memory. These shift maps are selectable over a wide range. <i>The shift point limitations are made, on the one hand, by the highest admissible engine speed for each application and, on the other hand, by the lowest engine speed that is practical for driving comfort and noise emission. The inputs of the shift point determination are the throttle position, the accelerator pedal position, and the vehicle speed</i> (determined by the transmission output speed)."</p> <p>E.g., page 13.14, "In addition to these functions, <i>different shift maps can be implemented into the data field of the TCU [Transmission Control Unit].</i> For example, it is possible to have one shift map for low fuel consumption, which has shift points in the range of the best efficiency of the engine, and additionally to have another map for power operation, where the shift points are placed at points of highest engine output power."</p>	<p>E.g., col. 2, line 64 to col. 3, line 3, "<i>The indicator 10 includes a shift-up indicating lamp 10a and a shift-down indicating lamp 10b.</i>"</p> <p><i>The indicator 10 may be assembled by light emitting [sic] diodes (LED) so as to perform shift-up and shift-down indications by up and down directed arrow marks.</i> Alternatively, the indicator 10 may also be replaced with other voice combining circuit so as to announce the shift operations by voice instead of the indications."</p> <p>E.g., col. 7, lines 10 to 17, "<i>In this step 42, shift-down display is performed. Namely in this case, the shift down display instruction signal from the microcomputer 5 is applied to the indicator 10 through the I/O port 6 and the shift-down indication lamp in the indicator 10 is illuminated,</i> thus indicating to the driver that speed change operation from the current shift position to the one step shifting down position SP<sub>-1</sub> is preferable."</p> <p>E.g. col. 7, lines 29 to 38, "However, <i>only when either one of the assumed fuel consumption rates above is better than the current fuel consumption rate B<sub>o</sub>, the corresponding shift-up lamp or shift-down lamp in the indicator 10 is illuminated,</i> thus indicating the necessity of the speed change operation."</p>
<p>said processor subsystem determining, based upon data received from said plurality of</p>	<p>E.g., page 12.4, "During coasting and braking, fuel consumption can be further reduced by shutting off the fuel until the engine speed decreases to slightly higher than the set idle speed. <i>The ECU</i></p>	<p>E.g., col. 2, lines 37 to 42, "<i>The microcomputer 5 further comprises an input/output port (I/O port) 6, a central processing unit (CPU) 7, a read only memory (ROM) 8, and a random access</i></p>

Limitation of '781 Patent Claim 7	Automotive Electronics Handbook (Jurgen)	U.S. Patent No. 4,559,599 (Toyota '599)
<p>sensors, when to activate said fuel overinjection circuit and when to activate said downshift notification circuit.</p>	<p><i>determines when fuel shutoff can occur by evaluating the throttle position, engine RPM, and vehicle speed.</i></p> <p>E.g., page 12.14, "Using the inputs of engine RPM and vehicle speed to the electronic control unit, thresholds can be established for limiting these variables with fuel cutoff. <i>When the maximum speed is achieved, the fuel injectors are shut off.</i> When the speed decreases below the threshold, fuel injection resumes."</p> <p>E.g., pages 13.7 to 13.9, "<i>The basic functions of the transmission control are the shift point control, the lockup control, engine torque control during shifting, related safety functions, and diagnostic functions for vehicle service.</i>"</p> <p>E.g., page 13.9, "The basic shift point control uses shift maps, which are defined in data in the unit memory. These shift maps are selectable over a wide range. <i>The shift point limitations are made, on the one hand, by the highest admissible engine speed for each application and, on the other hand, by the lowest engine speed that is practical for driving comfort and noise emission. The inputs of the shift point determination are the throttle position, the accelerator pedal position, and the vehicle speed</i> (determined by the transmission output speed)."</p>	<p><i>memory (RAM) 9.</i> In the microcomputer 5, there is provided a bus BUS which communicates the I/O port 6 and the CPU 7, ROM 8, and RAM 9."</p> <p>E.g., col. 2, lines 59 to 63, "<i>The input of the indicator 10 is connected to the output of the I/O port 6 so as to indicate each preferable shift position corresponding to the optimum fuel consumption rate in accordance with various parameters calculated.</i>"</p> <p>E.g., col. 5, line 63 to col. 6, line 2, "<i>Namely, in this step, the speed change operation indicating signal is applied to the indicator or display 10 from the microcomputer 5 through the I/O port 6. As a result, a particular lamp in this case, a shift up indicating lamp in the indicator 10, is illuminated, thus indicating to the driver that the speed change from current shift position to the one step shifting up position SP<sub>+1</sub> is preferable.</i>"</p>

Limitation of '781 Patent Claim 13	Automotive Electronics Handbook (Jurgen)	U.S. Patent No. 4,559,599 (Toyota '599)
<p>13. Apparatus for optimizing operation of a vehicle, comprising:</p>	<p>E.g., page 12.1, "The electronic engine control system consists of sensing devices which continuously measure the operating conditions of the engine, <i>an electronic control unit (ECU) which evaluates the sensor inputs using data tables and calculations and determines the output to the actuating devices</i>, and actuating devices which are commanded by the ECU to perform an action in response to the sensor inputs.</p> <p>The motive for using an electronic engine control system is to provide the needed accuracy and adaptability in order to minimize exhaust emissions and fuel consumption, <i>provide optimal driveability for all operating conditions</i>, minimize evaporative emissions, and provide system diagnosis when malfunctions occur."</p>	<p>E.g., Abstract, "<i>A shift indication apparatus</i> having an engine rotation sensor, a throttle valve sensor, and a shift position sensor, a microcomputer having a ROM and RAM for storing data corresponding to the engine speed, throttle valve openings, and the shift positions therein, and an indicator for indicating preferable shift positions to be performed by a driver in which a torque data map and a fuel consumption rate data map have stored in the ROM for calculating various torque and fuel consumption rates <i>so as to obtain preferable shift positions relating to optimum fuel consumption rate in accordance with said data detected. With this construction, it becomes possible for a driver to run his car in accordance with the indications of the shift operation on the indicator so as to enable the economical running of the car to be realized.</i>"</p>
<p>a plurality of sensors coupled to a vehicle having an engine, said plurality of sensors, which collectively monitor operation of said vehicle, including a road speed sensor, an engine speed sensor, a manifold pressure sensor and a throttle position sensor;</p>	<p>E.g., page 7.6, "There are several applications for rotational speed sensing. <i>First it is necessary to monitor engine speed.</i> This information is used for transmission control, engine control, cruise control, and possibly for a tachometer. Electronics and electronic sensing in the automobile were brought about by the need for higher efficiency engines, better fuel economy, increased power and performance, and lower emissions. Second, <i>wheel speed sensing is required</i> for use in transmissions, cruise control, speedometers, antilock brake systems (ABS), traction control (ASR), variable ratio power steering assist, four-wheel steering, and possibly in inertial navigation and air bag deployment applications."</p> <p>E.g., page 7.8, "In electronic transmission applications, <i>information from the road and engine speed sensors</i>, as well as torque data and throttle position are required for the MCU to select the optimum gear ratio."</p> <p>E.g., page 2.5, "Automotive specification and testing guidelines have been developed and published by the Society of Automotive Engineers (SAE) specifically for <i>manifold absolute pressure (MAP) sensors.</i>"</p> <p>E.g., page 2.7, "Manifold absolute pressure (MAP) is used as an</p>	<p>E.g., col. 2, lines 23 to 36, "Referring to FIG. 1, the shift indication apparatus with a manual transmission according to the present invention comprises <i>an engine speed sensor 1 for detecting the engine speed and for producing pulse signals of a frequency proportional to the engine speed</i>, a shift position sensor 2 for detecting the shift positions of the transmission, <i>a throttle sensor 3 for detecting the opening degree of the throttle valve by means of, for instance, a potentiometer</i>, an A/D converter 4 for converting analog signals from the throttle valve sensor 3 into digital signals, a microcomputer 5 for performing various calculations in accordance with the different signals from the sensors, and an indicator 10 for indicating the result of the calculations."</p> <p>E.g., col. 2, lines 43 to 48, "<i>The engine speed sensor 1</i> is mounted in a distributor (not shown) and the output of the sensor is connected to the input of the I/O port 6 so as to transmit the output pulses to the microcomputer 5 through the I/O port 6 and to store the data corresponding to the engine speed into the RAM 9."</p> <p>E.g., col. 2, lines 52 to 59, "Similarly, the output of <i>the throttle sensor 3</i> is connected through the A/D converter 4 to the input of the I/O port 6 so as to transmit the output signals thereof to the microcomputer 5 through the A/D converter 4 and to store the data corresponding to the throttle value opening into the RAM 9 after</p>



Limitation of '781 Patent Claim 13	Automotive Electronics Handbook (Jurgen)	U.S. Patent No. 4,559,599 (Toyota '599)
	<p>input to fuel and ignition control in internal combustion engine control systems. <i>The speed-density system that uses the MAP sensor</i> has been preferred over mass air flow (MAF) control because it's less expensive, but stricter emission standards are causing more manufacturers to use mass air flow for future models.”</p> <p>E.g., page 12.18, “To control the idle speed, the ECU uses inputs from the <i>throttle position sensor</i>, air conditioning, automatic transmission, power steering, charging system, engine RPM, and vehicle speed.”</p> <p>E.g., page 12.21, “The electronic injection unit also houses the <i>throttle position sensor</i> and, in some cases, an inlet air temperature sensor which provides operating condition information to the ECU.”</p>	<p>converting from the analog signals into the digital signals.”</p> <p>E.g., FIG. 1:</p>
<p>a processor subsystem, coupled to each one of said plurality of sensors, to receive data therefrom;</p>	<p>E.g., page 12.1, “The electronic engine control system consists of <i>sensing devices which continuously measure the operating conditions of the engine, an electronic control unit (ECU) which evaluates the sensor inputs</i> using data tables and calculations and determines the output to the actuating devices, and actuating devices which are commanded by the ECU to perform an action in response to the sensor inputs.”</p> <p>E.g., page 22.6, “During the entire operating time of the vehicle, <i>the ECUs are constantly supervising the sensors they are connected to.</i>”</p> <p>E.g., page 13.4, “On the functional side, the hardware configuration can be divided into power supply, input signal transfer circuits, output stages, and <i>microcontroller</i>, including peripheral</p>	<p>E.g., col. 2, lines 23 to 36, “Referring to FIG. 1, the shift indication apparatus with a manual transmission according to the present invention comprises an engine speed sensor 1 for detecting the engine speed and for producing pulse signals of a frequency proportional to the engine speed, a shift position sensor 2 for detecting the shift positions of the transmission, a throttle sensor 3 for detecting the opening degree of the throttle valve by means of, for instance, a potentiometer, an A/D converter 4 for converting analog signals from the throttle valve sensor 3 into digital signals, <i>a microcomputer 5 for performing various calculations in accordance with the different signals from the sensors</i>, and an indicator 10 for indicating the result of the calculations.”</p> <p>E.g., col. 2, lines 37 to 42, “<i>The microcomputer 5</i> further comprises an input/output port (I/O port) 6, <i>a central processing</i></p>

Limitation of '781 Patent Claim 13	Automotive Electronics Handbook (Jurgen)	U.S. Patent No. 4,559,599 (Toyota '599)
	<p>components and monitoring and safety circuits (Fig. 13.1)."</p> <p>E.g., Figure 13.1:</p> <p>FIG. 13.1 Overview of hardware parts</p> <p>E.g., page 14.3, "The speed sensor is one of the most critical parts in the system, because the <i>microcontroller calculates the vehicle speed from the speed sensor's signal</i> to within 1/32 m/h."</p>	<p><i>unit (CPU) 7, a read only memory (ROM) 8, and a random access memory (RAM) 9. In the microcomputer 5, there is provided a bus BUS which communicates the I/O port 6 and the CPU 7, ROM 8, and RAM 9.</i>"</p> <p>E.g., col. 2, lines 43 to 48, "The engine speed sensor 1 is mounted in a distributor (not shown) and <i>the output of the sensor is connected to the input of the I/O port 6 so as to transmit the output pulses to the microcomputer 5</i> through the I/O port 6 and to store the data corresponding to the engine speed into the RAM 9."</p> <p>E.g., col. 2, lines 52 to 59, "Similarly, <i>the output of the throttle sensor 3 is connected through the A/D converter 4 to the input of the I/O port 6 so as to transmit the output signals thereof to the microcomputer 5</i> through the A/D converter 4 and to store the data corresponding to the throttle value opening into the RAM 9 after converting from the analog signals into the digital signals."</p>
<p>a memory subsystem, coupled to said processor subsystem, said memory subsystem storing therein a manifold pressure set point, an engine speed set point and present and prior levels for each one of said</p>	<p>E.g., page 13.5, "The calculators inside the control units are usually microcontrollers. . . . <i>The memory devices for program and data are usually EPROMS.</i> Their storage capacity is, in present applications, up to 64 Kbytes. Future applications will necessitate storage sizes up to 128 Kbytes. The failure storages for diagnostics and the storage for adaptive data are in conventional applications,</p>	<p>E.g., col. 2, lines 37 to 42, "The microcomputer 5 further comprises an input/output port (I/O port) 6, a central processing unit (CPU) 7, <i>a read only memory (ROM) 8, and a random access memory (RAM) 9.</i> In the microcomputer 5, there is provided a bus BUS which communicates the I/O port 6 and the CPU 7, <i>ROM 8, and RAM 9.</i>"</p>

Limitation of '781 Patent Claim 13	Automotive Electronics Handbook (Jurgen)	U.S. Patent No. 4,559,599 (Toyota '599)
<p>plurality of sensors;</p>	<p>battery voltage-supplied RAMs. These are increasingly being replaced by EEPROMs.”</p> <p>E.g., page 12.9, “A subsystem of the fuel control system is lambda closed-loop control. . . .</p> <p>[T]he engine control unit uses an anticipatory control strategy that uses engine load and RPM to determine the approximate fuel requirement. <i>The engine load information is provided by the manifold pressure sensor for speed density systems and by the air meter for air flow and air mass measurement systems and by the throttle valve position sensor. The engine control unit contains data tables for combinations of load and RPM.</i> This allows for rapid response to changes in operating conditions. The lambda sensor still provides the feedback correction for each load/RPM point. . . .</p> <p>[T]he electronic control unit has a feature for adapting changes in the fuel required for the load/RPM points. <i>At each load/RPM point, the lambda sensor continuously provides information that allows the system to adjust the fuel to the commanded A/F ratio. The corrected information is stored in RAM (random access memory) so that the next time the engine reaches that operating point (load/RPM), the anticipatory value will require less correction. These values remain stored in the electronic control unit even after the engine is shut off.</i> Only if power to the electronic control unit is disrupted (i.e., due to a dead battery), will the correction be lost. In that case, the electronic control unit will revert back to the original production values that are written in ROM (read-only memory).”</p> <p>E.g., page 14.2, “Other safety-related items include <i>program code to detect abnormal operating conditions and preserving into memory the data points associated with the abnormal condition for later diagnostics.</i> Abnormal conditions, for example, could be an intermittent vehicle speed sensor, or erratic driver switch signals.”</p> <p>E.g., pages 22.2 to 22.3, “The most important test points of control</p>	<p>E.g., col. 3, lines 7 to 20, “<i>The torque data map indicative of torque curves T as shown in FIG. 2 has been stored in the ROM 8 in advance. The fuel consumption rate data map indicative of equal fuel consumption rate curves B as shown in FIG. 3 has been also stored in the ROM 8 in advance. In FIG. 2, each equal torque curve T was prepared by plotting and connecting equal torque points on the graph with respect to the engine speed vs. throttle valve opening.</i> In FIG. 3, each fuel consumption rate curve B was prepared by plotting and connecting equal fuel consumption rate points on a graph obtained in advance by experiment data with respect to the engine speed and the torques thus calculated.”</p> <p>E.g., col. 3, lines 44 to 61, “<i>In this case, as shown in FIG. 4, the operation of a main routine is started at a predetermined timing, e.g. periodical timing pulses from a timer (not shown) and the detection of the engine speed <math>N_e</math> from the sensor 1 is carried out and it is stored into the RAM 9 at the step 20. Then, the engine speed <math>N_e</math> is read from the RAM 9 and it is compared with a predetermined number <math>N (=1000 \text{ rpm})</math> to determine whether or not the <math>N_e</math> exceeds the value 1000 at the step 21.</i> If the result of the decision is YES, the next step 22 is executed. That is, in the step 22, the reading in of the opening of the throttle valve is performed through the throttle sensor 3 and the A/D converter 4. In the above case, if the result of the decision in step 21 is NO, the main routine is terminated by determining that the shift operation is not necessary and the engine speed <math>N_e</math> is read again at the predetermined timing and now the operation returns to the step 20.”</p> <p>E.g., Figure 4:</p>

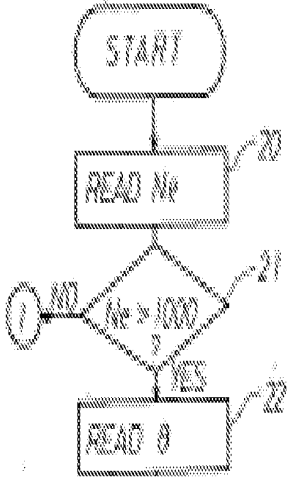
Limitation of '781 Patent Claim 13	Automotive Electronics Handbook (Jurgen)	U.S. Patent No. 4,559,599 (Toyota '599)
	<p>units and sensors are tied to a diagnostic connector which is plugged into the measuring instrument with a corresponding adapter for the respective vehicle. . . .</p> <p><i>Modern electronics in vehicles support diagnosis by comparing the registered actual value with the internally stored nominal values with the help of control units and their self-diagnosis, thus detecting faults."</i></p>	 <pre> graph TD     START([START]) --&gt; READ_Nn[READ Nn]     READ_Nn --&gt; DEC{Nn = 1000?}     DEC -- NO --&gt; READ_Nn     DEC -- YES --&gt; READ_0[READ 0]   </pre>
<p>a fuel overinjection notification circuit coupled to said processor subsystem, said fuel overinjection notification circuit issuing a notification that excessive fuel is being supplied to said engine of said vehicle;</p>	<p>E.g., page 12.22, "During an acceleration transition, the ECU adds a correction factor (an increase) to the commanded injector pulse width. The sudden increase in air results in a lean mixture which must be corrected swiftly to obtain good transitional response. <i>During a deceleration transition, the fuel can be shut off by simply not providing a pulse width signal to the injector to minimize exhaust emissions and fuel consumption."</i></p> <p>E.g., page 12.4, "During coasting and braking, fuel consumption can be further reduced by shutting off the fuel until the engine speed decreases to slightly higher than the set idle speed. <i>The ECU determines when fuel shutoff can occur by evaluating the throttle position, engine RPM, and vehicle speed."</i></p> <p>E.g., page 12.14, "Using the inputs of engine RPM and vehicle speed to the electronic control unit, thresholds can be established for limiting these variables with fuel cutoff. <i>When the maximum speed is achieved, the fuel injectors are shut off.</i> When the speed decreases below the threshold, fuel injection resumes."</p> <p>E.g., page 12.17, "<i>During transition to fuel cutoff, the ignition timing is retarded from its current setting to reduce engine torque</i></p>	

Limitation of '781 Patent Claim 13	Automotive Electronics Handbook (Jurgen)	U.S. Patent No. 4,559,599 (Toyota '599)
	<p><i>and to assist in engine braking. The fuel is then shut off.</i> During the transition, the throttle bypass valve or the main throttle valve may remain open for a short period to allow fresh air to oxidize the remaining unburned HC and CO to further reduce exhaust emissions. During development of the fuel cutoff strategy, the advantage of reduced emission effects and catalyst temperature control must be balanced against driveability requirements. The use of fuel cutoff may change the perceived amount of engine braking felt by the driver. In addition, care must be taken to avoid a 'bump' feel when entering the fuel cutoff mode, due to the change in torque."</p>	
<p>an upshift notification circuit coupled to said processor subsystem, said upshift notification circuit issuing a notification that said engine of said vehicle is being operated at an excessive engine speed;</p>	<p>E.g., page 13.7 to 13.9, "<i>The basic functions of the transmission control are the shift point control, the lockup control, engine torque control during shifting, related safety functions, and diagnostic functions for vehicle service.</i>"</p> <p>E.g., page 13.9, "The basic shift point control uses shift maps, which are defined in data in the unit memory. These shift maps are selectable over a wide range. <i>The shift point limitations are made, on the one hand, by the highest admissible engine speed for each application and, on the other hand, by the lowest engine speed that is practical for driving comfort and noise emission. The inputs of the shift point determination are the throttle position, the accelerator pedal position, and the vehicle speed</i> (determined by the transmission output speed)."</p> <p>E.g., page 13.14, "In addition to these functions, <i>different shift maps can be implemented into the data field of the TCU [Transmission Control Unit].</i> For example, it is possible to have one shift map for low fuel consumption, which has shift points in the range of the best efficiency of the engine, and additionally to have another map for power operation, where the shift points are placed at points of highest engine output power."</p>	<p>E.g., col. 2, line 64 to col. 3, line 3, "<i>The indicator 10 includes a shift-up indicating lamp 10a and a shift-down indicating lamp 10b.</i></p> <p><i>The indicator 10 may be assembled by light emitting [sic] diodes (LED) so as to perform shift-up and shift-down indications by up and down directed arrow marks.</i> Alternatively, the indicator 10 may also be replaced with other voice combining circuit so as to announce the shift operations by voice instead of the indications."</p> <p>E.g., col. 5, line 63 to col. 6, line 2, "Namely, in this step, the speed change operation indicating signal is applied to the indicator or display 10 from the microcomputer 5 through the I/O port 6. As a result, a particular lamp in this case, <i>a shift up indicating lamp in the indicator 10, is illuminated, thus indicating to the driver that the speed change from current shift position to the one step shifting up position SP<sub>+1</sub> is preferable.</i>"</p> <p>E.g. col. 7, lines 29 to 38, "However, <i>only when either one of the assumed fuel consumption rates above is better than the current fuel consumption rate B<sub>o</sub>, the corresponding shift-up lamp or shift-down lamp in the indicator 10 is illuminated,</i> thus indicating the necessity of the speed change operation."</p>
<p>a downshift notification circuit coupled to said processor subsystem, said downshift notification circuit</p>	<p>E.g., page 13.7 to 13.9, "<i>The basic functions of the transmission control are the shift point control, the lockup control, engine torque control during shifting, related safety functions, and</i></p>	<p>E.g., col. 2, line 64 to col. 3, line 3, "<i>The indicator 10 includes a shift-up indicating lamp 10a and a shift-down indicating lamp 10b.</i></p>

Limitation of '781 Patent Claim 13	Automotive Electronics Handbook (Jurgen)	U.S. Patent No. 4,559,599 (Toyota '599)
<p>issuing a notification that said engine of said vehicle is being operated at an insufficient engine speed;</p>	<p>diagnostic functions for vehicle service.”</p> <p>E.g., page 13.9, “The basic shift point control uses shift maps, which are defined in data in the unit memory. These shift maps are selectable over a wide range. <i>The shift point limitations are made, on the one hand, by the highest admissible engine speed for each application and, on the other hand, by the lowest engine speed that is practical for driving comfort and noise emission. The inputs of the shift point determination are the throttle position, the accelerator pedal position, and the vehicle speed</i> (determined by the transmission output speed).”</p> <p>E.g., page 13.14, “In addition to these functions, <i>different shift maps can be implemented into the data field of the TCU [Transmission Control Unit].</i> For example, it is possible to have one shift map for low fuel consumption, which has shift points in the range of the best efficiency of the engine, and additionally to have another map for power operation, where the shift points are placed at points of highest engine output power.”</p>	<p><i>The indicator 10 may be assembled by light emitting [sic] diodes (LED) so as to perform shift-up and shift-down indications by up and down directed arrow marks.</i> Alternatively, the indicator 10 may also be replaced with other voice combining circuit so as to announce the shift operations by voice instead of the indications.”</p> <p>E.g., col. 7, lines 10 to 17, “<i>In this step 42, shift-down display is performed. Namely in this case, the shift down display instruction signal from the microcomputer 5 is applied to the indicator 10 through the I/O port 6 and the shift-down indication lamp in the indicator 10 is illuminated,</i> thus indicating to the driver that speed change operation from the current shift position to the one step shifting down position SP<sub>1</sub> is preferable.”</p> <p>E.g. col. 7, lines 29 to 38, “<i>However, only when either one of the assumed fuel consumption rates above is better than the current fuel consumption rate B<sub>0</sub>, the corresponding shift-up lamp or shift-down lamp in the indicator 10 is illuminated,</i> thus indicating the necessity of the speed change operation.”</p>
<p>said processor subsystem determining, based upon data received from said plurality of sensors, when to activate said fuel overinjection circuit, said upshift notification circuit, and said downshift notification circuit.</p>	<p>E.g., page 12.4, “During coasting and braking, fuel consumption can be further reduced by shutting off the fuel until the engine speed decreases to slightly higher than the set idle speed. <i>The ECU determines when fuel shutoff can occur by evaluating the throttle position, engine RPM, and vehicle speed.</i>”</p> <p>E.g., page 12.14, “Using the inputs of engine RPM and vehicle speed to the electronic control unit, thresholds can be established for limiting these variables with fuel cutoff. <i>When the maximum speed is achieved, the fuel injectors are shut off.</i> When the speed decreases below the threshold, fuel injection resumes.”</p> <p>E.g., page 13.7 to 13.9, “<i>The basic functions of the transmission control are the shift point control, the lockup control, engine torque control during shifting, related safety functions, and diagnostic functions for vehicle service.</i>”</p> <p>E.g., page 13.9, “The basic shift point control uses shift maps,</p>	<p>E.g., col. 2, lines 37 to 42, “<i>The microcomputer 5 further comprises an input/output port (I/O port) 6, a central processing unit (CPU) 7, a read only memory (ROM) 8, and a random access memory (RAM) 9.</i> In the microcomputer 5, there is provided a bus BUS which communicates the I/O port 6 and the CPU 7, ROM 8, and RAM 9.”</p> <p>E.g., col. 2, lines 59 to 63, “<i>The input of the indicator 10 is connected to the output of the I/O port 6 so as to indicate each preferable shift position corresponding to the optimum fuel consumption rate in accordance with various parameters calculated.</i>”</p> <p>E.g., col. 5, line 63 to col. 6, line 2, “<i>Namely, in this step, the speed change operation indicating signal is applied to the indicator or display 10 from the microcomputer 5 through the I/O port 6. As a result, a particular lamp in this case, a shift up indicating lamp in the indicator 10, is illuminated, thus indicating</i></p>

Limitation of '781 Patent Claim 13	Automotive Electronics Handbook (Jurgen)	U.S. Patent No. 4,559,599 (Toyota '599)
	<p>which are defined in data in the unit memory. These shift maps are selectable over a wide range. <i>The shift point limitations are made, on the one hand, by the highest admissible engine speed for each application and, on the other hand, by the lowest engine speed that is practical for driving comfort and noise emission. The inputs of the shift point determination are the throttle position, the accelerator pedal position, and the vehicle speed (determined by the transmission output speed).</i></p>	<p><i>to the drive that the speed change from current shift position to the one step shifting up position <math>SP_{+1}</math> is preferable."</i></p>

3. Claims 1, 7, and 13 are Obvious in View of the Combination of Jurgen and Volkswagen '070

Limitation of '781 Patent Claim 1	Automotive Electronics Handbook (Jurgen)	German Patent Application Publication No. 29 26 070 (Volkswagen '070)
<p>1. Apparatus for optimizing operation of a vehicle, comprising:</p>	<p>E.g., page 12.1, “The electronic engine control system consists of sensing devices which continuously measure the operating conditions of the engine, <i>an electronic control unit (ECU) which evaluates the sensor inputs using data tables and calculations and determines the output to the actuating devices</i>, and actuating devices which are commanded by the ECU to perform an action in response to the sensor inputs.</p> <p>The motive for using an electronic engine control system is to provide the needed accuracy and adaptability in order to minimize exhaust emissions and fuel consumption, <i>provide optimal driveability for all operating conditions</i>, minimize evaporative emissions, and provide system diagnosis when malfunctions occur.”</p>	<p>E.g., page 5 (English translation), “The present invention is based on the objective of providing <i>a device that assists the operator of the internal combustion engine equipped with a conventional transmission</i>, i.e., the driver of a motor vehicle, for example, in setting an operating point of the engine that is advantageous in terms of consumption, by way of gear shift operations.”</p>
<p>a plurality of sensors coupled to a vehicle having an engine, said plurality of sensors, which collectively monitor operation of said vehicle, including a road speed sensor, an engine speed sensor, a manifold pressure sensor and a throttle position sensor;</p>	<p>E.g., page 7.6, “There are several applications for rotational speed sensing. <i>First it is necessary to monitor engine speed</i>. This information is used for transmission control, engine control, cruise control, and possibly for a tachometer. Electronics and electronic sensing in the automobile were brought about by the need for higher efficiency engines, better fuel economy, increased power and performance, and lower emissions. Second, <i>wheel speed sensing is required</i> for use in transmissions, cruise control, speedometers, antilock brake systems (ABS), traction control (ASR), variable ratio power steering assist, four-wheel steering, and possibly in inertial navigation and air bag deployment applications.”</p> <p>E.g., page 7.8, “In electronic transmission applications, <i>information from the road and engine speed sensors</i>, as well as torque data and throttle position are required for the MCU to select the optimum gear ratio.”</p> <p>E.g., page 2.5, “Automotive specification and testing guidelines have been developed and published by the Society of Automotive Engineers (SAE) specifically for <i>manifold</i></p>	<p>E.g., page 6 (English translation), “As can be seen when viewing Figure 1 to begin with, output N of the engine has been plotted across engine speed n. a is the curve of the output at full load, b is a line that represents a constant setting of the output control element, i.e., a line that represents a constant <i>throttle valve angle</i> in a carburetor engine. As a measure thereof, in addition to the <i>throttle valve angle</i> itself, it is also possible to use the <i>induction manifold vacuum</i>. . . The operating ranges I and II are further delimited by <i>engine speed</i> values n<sub>1</sub> or n<sub>2</sub>, the first of which usually lies between approximately 20 to 50% of the maximum engine speed, and the second usually lies between approximately 40 and 70% of the maximum engine speed.”</p> <p>E.g., page 8 (English translation), “<i>The engine speed signal is obtained with the aid of known sensor systems</i>, which therefore need not be described in further detail here.”</p> <p>E.g., page 9 (English translation), “It is useful if in addition to this device, a display of the route-specific fuel consumption is provided in a vehicle. Such display devices are known per se; they generally utilize the <i>injection manifold vacuum</i> as a measure of fuel</p>

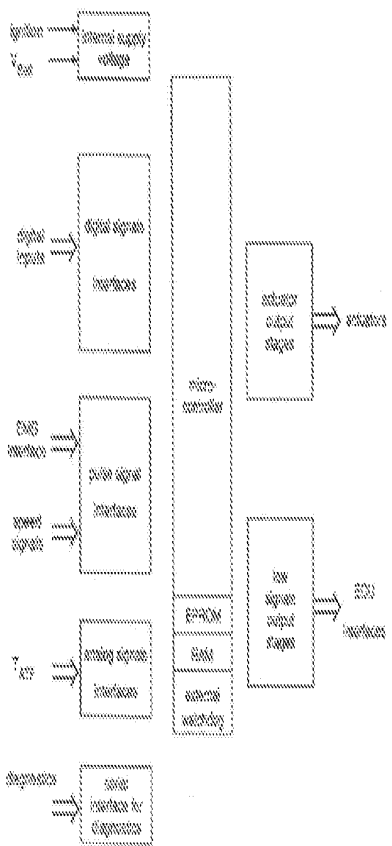
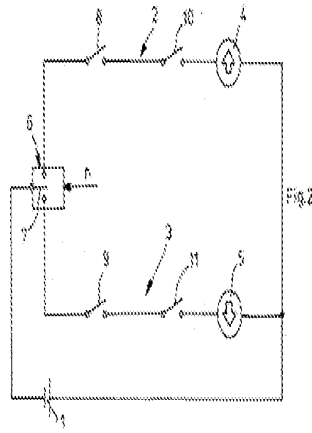

Limitation of '781 Patent Claim 1	Automotive Electronics Handbook (Jurgen)	German Patent Application Publication No. 29 26 070 (Volkswagen '070)
	<p><i>absolute pressure (MAP) sensors.</i>"</p> <p>E.g., page 2.7, "Manifold absolute pressure (MAP) is used as an input to fuel and ignition control in internal combustion engine control systems. <i>The speed-density system that uses the MAP sensor</i> has been preferred over mass air flow (MAF) control because it's less expensive, but stricter emission standards are causing more manufacturers to use mass air flow for future models."</p> <p>E.g., page 12.18, "To control the idle speed, the ECU uses inputs from the <i>throttle position sensor</i>, air conditioning, automatic transmission, power steering, charging system, engine RPM, and vehicle speed."</p> <p>E.g., page 12.21, "The electronic injection unit also houses the <i>throttle position sensor</i> and, in some cases, an inlet air temperature sensor which provides operating condition information to the ECU."</p>	<p>consumption."</p>
<p>a processor subsystem, coupled to each one of said plurality of sensors, to receive data therefrom;</p>	<p>E.g., page 12.1, "The electronic engine control system consists of <i>sensing devices which continuously measure the operating conditions of the engine, an electronic control unit (ECU) which evaluates the sensor inputs</i> using data tables and calculations and determines the output to the actuating devices, and actuating devices which are commanded by the ECU to perform an action in response to the sensor inputs."</p> <p>E.g., page 22.6, "During the entire operating time of the vehicle, <i>the ECUs are constantly supervising the sensors they are connected to.</i>"</p> <p>E.g., page 13.4, "On the functional side, the hardware configuration can be divided into power supply, input signal transfer circuits, output stages, and <i>microcontroller</i>, including peripheral components and monitoring and safety circuits (Fig. 13.1)."</p> <p>E.g., Figure 13.1:</p>	<p>E.g., pages 7 to 8 (English translation), "<i>The two control circuits 2 and 3 are selectively closed by engine-speed dependent change-over switch 6, to which a signal that corresponds to the individual engine speed n is forwarded</i> and which is developed in such a way that at engine speeds that are greater than predefined engine speed <math>n_1</math> (see Figure 1), its shift lever pivots upwardly in Figure 2, but at engine speeds that are smaller than predefined engine speed <math>n_2</math>, it pivots in the downward direction from a neutral center position, which it therefore assumes when engine speed values between <math>n_1</math> and <math>n_2</math> are present."</p> <p>E.g., Figure 2:</p>

Limitation of '781 Patent Claim 1	Automotive Electronics Handbook (Jurgen)	German Patent Application Publication No. 29 26 070 (Volkswagen '070)
	 <p>FIG. 2.3.1 Overview of hardware parts</p> <p>E.g., page 14.3, “The speed sensor is one of the most critical parts in the system, because the <i>microcontroller calculates the vehicle speed from the speed sensor’s signal</i> to within 1/32 m/h.”</p>	 <p>Fig. 2</p> <p>E.g., page 6 (English translation), “As can be seen when viewing Figure 1 to begin with, <i>output N of the engine has been plotted across engine speed n.</i>”</p> <p>E.g., page 6 (English translation), “<i>The numerical values of the limits of the two operating ranges I and II are of course dependent on the individual situation.</i> In general, it can be said that these two operating ranges lie in such a way that by shift</p>
<p>a memory subsystem, coupled to said processor subsystem, said memory subsystem storing therein a manifold pressure set point, an RPM set point, and present and prior levels for each one of said plurality of sensors;</p>	<p>E.g., page 13.5, “The calculators inside the control units are usually microcontrollers. . . . <i>The memory devices for program and data are usually EPROMs.</i> Their storage capacity is, in present applications, up to 64 Kbytes. Future applications will necessitate storage sizes up to 128 Kbytes. The failure storages for diagnostics and the storage for adaptive data are in conventional applications, battery voltage-supplied RAMs. These are increasingly being replaced by EEPROMs.”</p>	<p>E.g., page 6 (English translation), “As can be seen when viewing Figure 1 to begin with, <i>output N of the engine has been plotted across engine speed n.</i>”</p> <p>E.g., page 6 (English translation), “<i>The numerical values of the limits of the two operating ranges I and II are of course dependent on the individual situation.</i> In general, it can be said that these two operating ranges lie in such a way that by shift</p>

Limitation of '781 Patent Claim 1	Automotive Electronics Handbook (Jurgen)	German Patent Application Publication No. 29 26 070 (Volkswagen '070)
	<p>E.g., page 12.9, "A subsystem of the fuel control system is lambda closed-loop control. . . .</p> <p>[T]he engine control unit uses an anticipatory control strategy that uses engine load and RPM to determine the approximate fuel requirement. <i>The engine load information is provided by the manifold pressure sensor for speed density systems and by the air meter for air flow and air mass measurement systems and by the throttle valve position sensor. The engine control unit contains data tables for combinations of load and RPM.</i> This allows for rapid response to changes in operating conditions. The lambda sensor still provides the feedback correction for each load/RPM point. . . .</p> <p>[T]he electronic control unit has a feature for adapting changes in the fuel required for the load/RPM points. <i>At each load/RPM point, the lambda sensor continuously provides information that allows the system to adjust the fuel to the commanded A/F ratio. The corrected information is stored in RAM (random access memory) so that the next time the engine reaches that operating point (load/RPM), the anticipatory value will require less correction. These values remain stored in the electronic control unit even after the engine is shut off.</i> Only if power to the electronic control unit is disrupted (i.e., due to a dead battery), will the correction be lost. In that case, the electronic control unit will revert back to the original production values that are written in ROM (read-only memory)."</p> <p>E.g., page 14.2, "Other safety-related items include <i>program code to detect abnormal operating conditions and preserving into memory the data points associated with the abnormal condition for later diagnostics.</i> Abnormal conditions, for example, could be an intermittent vehicle speed sensor, or erratic driver switch signals."</p> <p>E.g., pages 22.2 to 22.3, "The most important test points of control units and sensors are tied to a diagnostic connector which is</p>	<p>operations, it is possible to achieve operating points in the output/engine speed diagram that are more favorable in terms of fuel consumption."</p> <p>E.g., page 8 (English translation), "<i>Furthermore, to define the two operating ranges I and II, load-dependent switches 8 and 9 are provided in control circuits 2 and 3 in Figure 2, the first of which is closed only below the line denoted by b in Figure 1, and switch 9 is closed only above the line denoted by c in Figure 1.</i>"</p> <p>E.g., Figure 1:</p> <p>Fig. 1</p>

Limitation of '781 Patent Claim 1	Automotive Electronics Handbook (Jurgen)	German Patent Application Publication No. 29 26 070 (Volkswagen '070)
	<p>plugged into the measuring instrument with a corresponding adapter for the respective vehicle. . . .</p> <p><i>Modern electronics in vehicles support diagnosis by comparing the registered actual value with the internally stored nominal values with the help of control units and their self-diagnosis, thus detecting faults.</i>"</p>	
<p>a fuel overinjection notification circuit coupled to said processor subsystem, said fuel overinjection notification circuit issuing a notification that excessive fuel is being supplied to said engine of said vehicle;</p>	<p>E.g., page 12.22, "During an acceleration transition, the ECU adds a correction factor (an increase) to the commanded injector pulse width. The sudden increase in air results in a lean mixture which must be corrected swiftly to obtain good transitional response.</p> <p><i>During a deceleration transition, the fuel can be shut off by simply not providing a pulse width signal to the injector to minimize exhaust emissions and fuel consumption.</i>"</p> <p>E.g., page 12.4, "During coasting and braking, fuel consumption can be further reduced by shutting off the fuel until the engine speed decreases to slightly higher than the set idle speed. <i>The ECU determines when fuel shutoff can occur by evaluating the throttle position, engine RPM, and vehicle speed.</i>"</p> <p>E.g., page 12.14, "Using the inputs of engine RPM and vehicle speed to the electronic control unit, thresholds can be established for limiting these variables with fuel cutoff. <i>When the maximum speed is achieved, the fuel injectors are shut off.</i> When the speed decreases below the threshold, fuel injection resumes."</p> <p>E.g., page 12.17, "<i>During transition to fuel cutoff, the ignition timing is retarded from its current setting to reduce engine torque and to assist in engine braking. The fuel is then shut off.</i> During the transition, the throttle bypass valve or the main throttle valve may remain open for a short period to allow fresh air to oxidize the remaining unburned HC and CO to further reduce exhaust emissions. During development of the fuel cutoff strategy, the advantage of reduced emission effects and catalyst temperature control must be balanced against driveability requirements. The use of fuel cutoff may change the perceived amount of engine braking felt by the driver. In addition, care must be taken to avoid a 'bump'</p>	<p>E.g., page 9 (English translation), "It is useful if in addition to this device, <i>a display of the route-specific fuel consumption is provided in a vehicle.</i> Such display devices are known per se; they generally utilize the injection manifold vacuum as a measure of fuel consumption."</p>

Limitation of '781 Patent Claim 1	Automotive Electronics Handbook (Jurgen)	German Patent Application Publication No. 29 26 070 (Volkswagen '070)
	feel when entering the fuel cutoff mode, due to the change in torque.”	
<p>an upshift notification circuit coupled to said processor subsystem, said upshift notification circuit issuing a notification that said engine of said vehicle is being operated at an excessive speed;</p>	<p>E.g., page 13.7 to 13.9, “<i>The basic functions of the transmission control are the shift point control, the lockup control, engine torque control during shifting, related safety functions, and diagnostic functions for vehicle service.</i>”</p> <p>E.g., page 13.9, “The basic shift point control uses shift maps, which are defined in data in the unit memory. These shift maps are selectable over a wide range. <i>The shift point limitations are made, on the one hand, by the highest admissible engine speed for each application and, on the other hand, by the lowest engine speed that is practical for driving comfort and noise emission. The inputs of the shift point determination are the throttle position, the accelerator pedal position, and the vehicle speed (determined by the transmission output speed).</i>”</p> <p>E.g., page 13.14, “In addition to these functions, <i>different shift maps can be implemented into the data field of the TCU [Transmission Control Unit].</i> For example, it is possible to have one shift map for low fuel consumption, which has shift points in the range of the best efficiency of the engine, and additionally to have another map for power operation, where the shift points are placed at points of highest engine output power.”</p>	<p>E.g., pages 6 to 7 (English translation), “Looking initially at operating range I remote from full load, <i>the desired output at a lower specific fuel consumption is able to be achieved after upshifting into the next higher gear</i>, at an operating point that lies to the left of operating range I in the diagram of Figure 1. <i>Accordingly, the device of the present invention generates a signal that asks the operator, i.e., normally the driver, to shift to a higher gear, which is indicated in Figure 1 by the upward pointing arrow within operating range I.</i>”</p> <p>E.g., pages 7 to 8 (English translation), “The two control circuits 2 and 3 are selectively closed by engine-speed dependent change-over switch 6, to which a signal that corresponds to the individual engine speed <math>n</math> is forwarded and which is developed in such a way that <i>at engine speeds that are greater than predefined engine speed <math>n_1</math> (see Figure 1), its shift lever pivots upwardly in Figure 2, but at engine speeds that are smaller than predefined engine speed <math>n_2</math>, it pivots in the downward direction from a neutral center position</i>, which it therefore assumes when engine speed values between <math>n_1</math> and <math>n_2</math> are present.”</p> <p>E.g., Figure 1:</p>

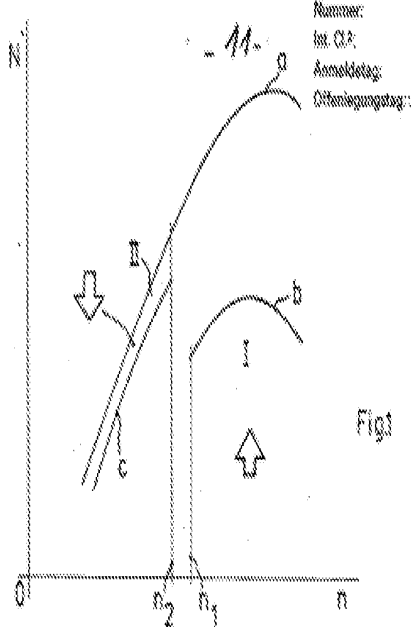
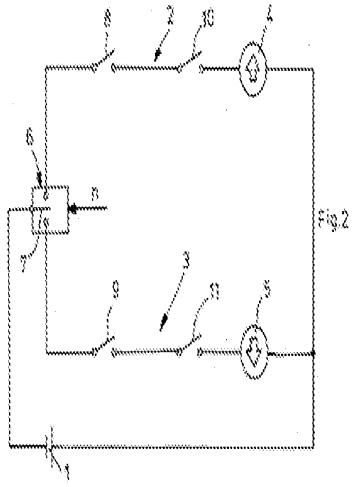
Limitation of '781 Patent Claim 1	Automotive Electronics Handbook (Jurgen)	German Patent Application Publication No. 29 26 070 (Volkswagen '070)
		 <p>Nummer: Int. Cl.: Anmeldetag: Offenlegungstag:</p> <p>Fig.1</p> <p>E.g., Figure 2:</p>  <p>Fig.2</p>
said processor subsystem determining, based upon data received from said plurality of	E.g., page 12.4, "During coasting and braking, fuel consumption can be further reduced by shutting off the fuel until the engine speed decreases to slightly higher than the set idle speed. <i>The ECU</i>	E.g., pages 6 to 7 (English translation), "Looking initially at operating range I remote from full load, the desired output at a lower specific fuel consumption is able to be achieved after

Limitation of '781 Patent Claim 1	Automotive Electronics Handbook (Jurgen)	German Patent Application Publication No. 29 26 070 (Volkswagen '070)
<p>sensors, when to activate said fuel overinjection circuit and when to activate said upshift notification circuit.</p>	<p><i>determines when fuel shutoff can occur by evaluating the throttle position, engine RPM, and vehicle speed.</i></p> <p>E.g., page 12.14, "Using the inputs of engine RPM and vehicle speed to the electronic control unit, thresholds can be established for limiting these variables with fuel cutoff. <i>When the maximum speed is achieved, the fuel injectors are shut off.</i> When the speed decreases below the threshold, fuel injection resumes."</p> <p>E.g., page 13.7 to 13.9, "<i>The basic functions of the transmission control are the shift point control, the lockup control, engine torque control during shifting, related safety functions, and diagnostic functions for vehicle service.</i>"</p> <p>E.g., page 13.9, "The basic shift point control uses shift maps, which are defined in data in the unit memory. These shift maps are selectable over a wide range. <i>The shift point limitations are made, on the one hand, by the highest admissible engine speed for each application and, on the other hand, by the lowest engine speed that is practical for driving comfort and noise emission. The inputs of the shift point determination are the throttle position, the accelerator pedal position, and the vehicle speed (determined by the transmission output speed).</i>"</p>	<p>upshifting into the next higher gear, at an operating point that lies to the left of operating range I in the diagram of Figure 1. <i>Accordingly, the device of the present invention generates a signal that asks the operator, i.e., normally the driver, to shift to a higher gear, which is indicated in Figure 1 by the upward pointing arrow within operating range I.</i>"</p> <p>E.g., pages 7 to 8 (English translation), "The two control circuits 2 and 3 are selectively closed by engine-speed dependent change-over switch 6, to which a signal that corresponds to the individual engine speed <math>n</math> is forwarded and which is developed in such a way that <i>at engine speeds that are greater than predefined engine speed <math>n_1</math> (see Figure 1), its shift lever pivots upwardly in Figure 2, but at engine speeds that are smaller than predefined engine speed <math>n_2</math>, it pivots in the downward direction from a neutral center position, which it therefore assumes when engine speed values between <math>n_1</math> and <math>n_2</math> are present.</i>"</p> <p>E.g., page 7 (English translation), "<i>When the operating point lies in operating range II, the device according to the present invention generates a signal that asks the driver to downshift, which is indicated by the downward pointing arrow at operating range II in Figure 1.</i>"</p> <p>E.g., page 9 (English translation), "It is useful if in addition to this device, <i>a display of the route-specific fuel consumption is provided in a vehicle. Such display devices are known per se; they generally utilize the injection manifold vacuum as a measure of fuel consumption.</i>"</p>

Limitation of '781 Patent Claim 7	Automotive Electronics Handbook (Jurgen)	German Patent Application Publication No. 29 26 070 (Volkswagen '070)
<p>7. Apparatus for optimizing operation of a vehicle, comprising:</p>	<p>E.g., page 12.1, "The electronic engine control system consists of sensing devices which continuously measure the operating conditions of the engine, <i>an electronic control unit (ECU) which evaluates the sensor inputs using data tables and calculations and determines the output to the actuating devices</i>, and actuating devices which are commanded by the ECU to perform an action in response to the sensor inputs.</p> <p>The motive for using an electronic engine control system is to provide the needed accuracy and adaptability in order to minimize exhaust emissions and fuel consumption, <i>provide optimal driveability for all operating conditions</i>, minimize evaporative emissions, and provide system diagnosis when malfunctions occur."</p>	<p>E.g., page 5 (English translation), "The present invention is based on the objective of providing <i>a device that assists the operator of the internal combustion engine equipped with a conventional transmission</i>, i.e., the driver of a motor vehicle, for example, in setting an operating point of the engine that is advantageous in terms of consumption, by way of gear shift operations."</p>
<p>a plurality of sensors coupled to a vehicle having an engine, said plurality of sensors, which collectively monitor operation of said vehicle, including a road speed sensor, a manifold pressure sensor and a throttle position sensor;</p>	<p>E.g., page 7.6, "There are several applications for rotational speed sensing. <i>First it is necessary to monitor engine speed.</i> This information is used for transmission control, engine control, cruise control, and possibly for a tachometer. Electronics and electronic sensing in the automobile were brought about by the need for higher efficiency engines, better fuel economy, increased power and performance, and lower emissions. Second, <i>wheel speed sensing is required</i> for use in transmissions, cruise control, speedometers, antilock brake systems (ABS), traction control (ASR), variable ratio power steering assist, four-wheel steering, and possibly in inertial navigation and air bag deployment applications."</p> <p>E.g., page 7.8, "In electronic transmission applications, <i>information from the road and engine speed sensors</i>, as well as torque data and throttle position are required for the MCU to select the optimum gear ratio."</p> <p>E.g., page 2.5, "Automotive specification and testing guidelines have been developed and published by the Society of Automotive Engineers (SAE) specifically for <i>manifold absolute pressure (MAP) sensors.</i>"</p>	<p>E.g., page 6 (English translation), "As can be seen when viewing Figure 1 to begin with, output N of the engine has been plotted across engine speed n. a is the curve of the output at full load, b is a line that represents a constant setting of the output control element, i.e., a line that represents a constant <i>throttle valve angle</i> in a carburetor engine. As a measure thereof, in addition to the <i>throttle valve angle</i> itself, it is also possible to use the <i>induction manifold vacuum</i>. . . . The operating ranges I and II are further delimited by <i>engine speed</i> values <math>n_1</math> or <math>n_2</math>, the first of which usually lies between approximately 20 to 50% of the maximum engine speed, and the second usually lies between approximately 40 and 70% of the maximum engine speed."</p> <p>E.g., page 8 (English translation), "<i>The engine speed signal is obtained with the aid of known sensor systems</i>, which therefore need not be described in further detail here."</p> <p>E.g., page 9 (English translation), "It is useful if in addition to this device, a display of the route-specific fuel consumption is provided in a vehicle. Such display devices are known per se; they generally utilize the <i>injection manifold vacuum</i> as a measure of fuel consumption."</p>

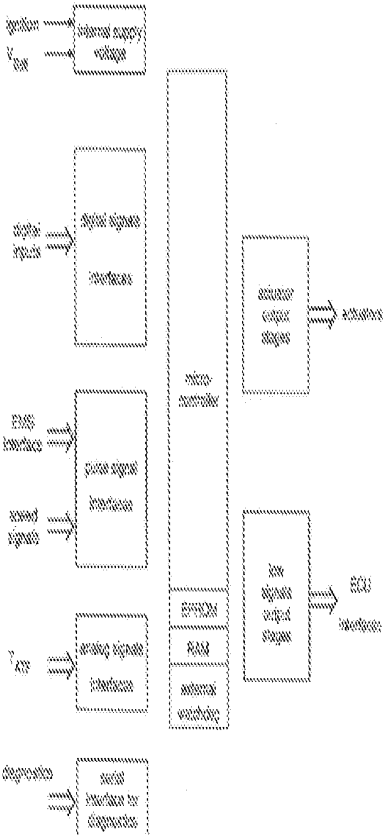
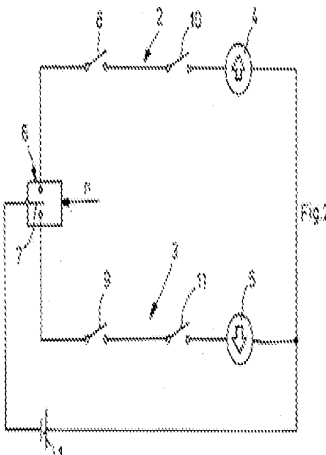

Limitation of '781 Patent Claim 7	Automotive Electronics Handbook (Jurgen)	German Patent Application Publication No. 29 26 070 (Volkswagen '070)
	<p>E.g., page 2.7, “Manifold absolute pressure (MAP) is used as an input to fuel and ignition control in internal combustion engine control systems. <i>The speed-density system that uses the MAP sensor</i> has been preferred over mass air flow (MAF) control because it's less expensive, but stricter emission standards are causing more manufacturers to use mass air flow for future models.”</p> <p>E.g., page 12.18, “To control the idle speed, the ECU uses inputs from the <i>throttle position sensor</i>, air conditioning, automatic transmission, power steering, charging system, engine RPM, and vehicle speed.”</p> <p>E.g., page 12.21, “The electronic injection unit also houses the <i>throttle position sensor</i> and, in some cases, an inlet air temperature sensor which provides operating condition information to the ECU.”</p>	
<p>a processor subsystem, coupled to each one of said plurality of sensors, to receive data therefrom;</p>	<p>E.g., page 12.1, “The electronic engine control system consists of <i>sensing devices which continuously measure the operating conditions of the engine, an electronic control unit (ECU) which evaluates the sensor inputs</i> using data tables and calculations and determines the output to the actuating devices, and actuating devices which are commanded by the ECU to perform an action in response to the sensor inputs.”</p> <p>E.g., page 22.6, “During the entire operating time of the vehicle, <i>the ECUs are constantly supervising the sensors they are connected to.</i>”</p> <p>E.g., page 13.4, “On the functional side, the hardware configuration can be divided into power supply, input signal transfer circuits, output stages, and <i>microcontroller</i>, including peripheral components and monitoring and safety circuits (Fig. 13.1).”</p> <p>E.g., Figure 13.1:</p>	<p>E.g., pages 7 to 8 (English translation), “<i>The two control circuits 2 and 3 are selectively closed by engine-speed dependent change-over switch 6, to which a signal that corresponds to the individual engine speed n is forwarded</i> and which is developed in such a way that at engine speeds that are greater than predefined engine speed <math>n_1</math> (see Figure 1), its shift lever pivots upwardly in Figure 2, but at engine speeds that are smaller than predefined engine speed <math>n_2</math>, it pivots in the downward direction from a neutral center position, which it therefore assumes when engine speed values between <math>n_1</math> and <math>n_2</math> are present.”</p> <p>E.g., Figure 2:</p>

Limitation of '781 Patent Claim 7	Automotive Electronics Handbook (Jurgen)	German Patent Application Publication No. 29 26 070 (Volkswagen '070)
	 <p>FIGURE 13.3: Overview of hardware parts</p> <p>E.g., page 14.3, "The speed sensor is one of the most critical parts in the system, because the <i>microcontroller calculates the vehicle speed from the speed sensor's signal</i> to within 1/32 m/h."</p>	 <p>Fig. 2</p> <p>E.g., page 6 (English translation), "As can be seen when viewing Figure 1 to begin with, <i>output N of the engine has been plotted across engine speed n.</i>"</p> <p>E.g., page 6 (English translation), "<i>The numerical values of the limits of the two operating ranges I and II are of course dependent on the individual situation.</i> In general, it can be said that these two operating ranges lie in such a way that by shift operations, it is possible to achieve</p>
<p>a memory subsystem, coupled to said processor subsystem, said memory subsystem storing therein a manifold pressure set point and present and prior levels for each one of said plurality of sensors;</p>	<p>E.g., page 13.5, "The calculators inside the control units are usually microcontrollers. . . . <i>The memory devices for program and data are usually EPROMS.</i> Their storage capacity is, in present applications, up to 64 Kbytes. Future applications will necessitate storage sizes up to 128 Kbytes. The failure storages for diagnostics and the storage for adaptive data are in conventional applications, battery voltage-supplied RAMs. These are increasingly being replaced by EEPROMs."</p>	<p>E.g., page 6 (English translation), "As can be seen when viewing Figure 1 to begin with, <i>output N of the engine has been plotted across engine speed n.</i>"</p> <p>E.g., page 6 (English translation), "<i>The numerical values of the limits of the two operating ranges I and II are of course dependent on the individual situation.</i> In general, it can be said that these two operating ranges lie in such a way that by shift operations, it is possible to achieve</p>

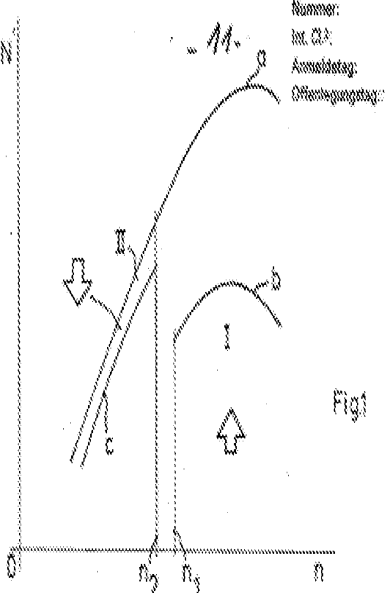
Limitation of '781 Patent Claim 7	Automotive Electronics Handbook (Jurgen)	German Patent Application Publication No. 29 26 070 (Volkswagen '070)
	<p>E.g., page 12.9, "A subsystem of the fuel control system is lambda closed-loop control. . . ."</p> <p>[T]he engine control unit uses an anticipatory control strategy that uses engine load and RPM to determine the approximate fuel requirement. <i>The engine load information is provided by the manifold pressure sensor for speed density systems and by the air meter for air flow and air mass measurement systems and by the throttle valve position sensor. The engine control unit contains data tables for combinations of load and RPM.</i> This allows for rapid response to changes in operating conditions. The lambda sensor still provides the feedback correction for each load/RPM point. . . .</p> <p>[T]he electronic control unit has a feature for adapting changes in the fuel required for the load/RPM points. <i>At each load/RPM point, the lambda sensor continuously provides information that allows the system to adjust the fuel to the commanded A/F ratio. The corrected information is stored in RAM (random access memory) so that the next time the engine reaches that operating point (load/RPM), the anticipatory value will require less correction. These values remain stored in the electronic control unit even after the engine is shut off.</i> Only if power to the electronic control unit is disrupted (i.e., due to a dead battery), will the correction be lost. In that case, the electronic control unit will revert back to the original production values that are written in ROM (read-only memory)."</p> <p>E.g., page 14.2, "Other safety-related items include <i>program code to detect abnormal operating conditions and preserving into memory the data points associated with the abnormal condition for later diagnostics.</i> Abnormal conditions, for example, could be an intermittent vehicle speed sensor, or erratic driver switch signals."</p> <p>E.g., pages 22.2 to 22.3, "The most important test points of control units and sensors are tied to a diagnostic connector which</p>	<p>operating points in the output/engine speed diagram that are more favorable in terms of fuel consumption."</p> <p>E.g., page 8 (English translation), "<i>Furthermore, to define the two operating ranges I and II, load-dependent switches 8 and 9 are provided in control circuits 2 and 3 in Figure 2, the first of which is closed only below the line denoted by b in Figure 1, and switch 9 is closed only above the line denoted by c in Figure 1.</i>"</p> <p>E.g., Figure 1:</p> 

Limitation of '781 Patent Claim 7	Automotive Electronics Handbook (Jurgen)	German Patent Application Publication No. 29 26 070 (Volkswagen '070)
	<p>is plugged into the measuring instrument with a corresponding adapter for the respective vehicle. . . .</p> <p><i>Modern electronics in vehicles support diagnosis by comparing the registered actual value with the internally stored nominal values with the help of control units and their self-diagnosis, thus detecting faults."</i></p>	
<p>a fuel overinjection notification circuit coupled to said processor subsystem, said fuel overinjection notification circuit issuing a notification that excessive fuel is being supplied to said engine of said vehicle;</p>	<p>E.g., page 12.22, "During an acceleration transition, the ECU adds a correction factor (an increase) to the commanded injector pulse width. The sudden increase in air results in a lean mixture which must be corrected swiftly to obtain good transitional response. <i>During a deceleration transition, the fuel can be shut off by simply not providing a pulse width signal to the injector to minimize exhaust emissions and fuel consumption."</i></p> <p>E.g., page 12.4, "During coasting and braking, fuel consumption can be further reduced by shutting off the fuel until the engine speed decreases to slightly higher than the set idle speed. <i>The ECU determines when fuel shutoff can occur by evaluating the throttle position, engine RPM, and vehicle speed."</i></p> <p>E.g., page 12.14, "Using the inputs of engine RPM and vehicle speed to the electronic control unit, thresholds can be established for limiting these variables with fuel cutoff. <i>When the maximum speed is achieved, the fuel injectors are shut off.</i> When the speed decreases below the threshold, fuel injection resumes."</p> <p>E.g., page 12.17, "<i>During transition to fuel cutoff, the ignition timing is retarded from its current setting to reduce engine torque and to assist in engine braking. The fuel is then shut off.</i> During the transition, the throttle bypass valve or the main throttle valve may remain open for a short period to allow fresh air to oxidize the remaining unburned HC and CO to further reduce exhaust emissions. During development of the fuel cutoff strategy, the advantage of reduced emission effects and catalyst temperature control must be balanced against driveability requirements. The use of fuel cutoff may change the perceived</p>	<p>E.g., page 9 (English translation), "It is useful if in addition to this device, <i>a display of the route-specific fuel consumption is provided in a vehicle.</i> Such display devices are known per se; they generally utilize the injection manifold vacuum as a measure of fuel consumption."</p>

Limitation of '781 Patent Claim 7	Automotive Electronics Handbook (Jurgen)	German Patent Application Publication No. 29 26 070 (Volkswagen '070)
	<p>amount of engine braking felt by the driver. In addition, care must be taken to avoid a 'bump' feel when entering the fuel cutoff mode, due to the change in torque."</p>	
<p>a downshift notification circuit coupled to said processor subsystem, said downshift notification circuit issuing a notification that said engine of said vehicle is being operated at an insufficient engine speed; and</p>	<p>E.g., page 13.7 to 13.9, "<b><i>The basic functions of the transmission control are the shift point control</i></b>, the lockup control, engine torque control during shifting, related safety functions, and diagnostic functions for vehicle service."</p> <p>E.g., page 13.9, "The basic shift point control uses shift maps, which are defined in data in the unit memory. These shift maps are selectable over a wide range. <b><i>The shift point limitations are made</i></b>, on the one hand, by the highest admissible engine speed for each application and, on the other hand, <b><i>by the lowest engine speed that is practical for driving comfort and noise emission. The inputs of the shift point determination are the throttle position, the accelerator pedal position, and the vehicle speed</i></b> (determined by the transmission output speed)."</p> <p>E.g., page 13.14, "In addition to these functions, <b><i>different shift maps can be implemented into the data field of the TCU [Transmission Control Unit]</i></b>. For example, it is possible to have one shift map for low fuel consumption, which has shift points in the range of the best efficiency of the engine, and additionally to have another map for power operation, where the shift points are placed at points of highest engine output power."</p>	<p>E.g., pages 6 to 7 (English translation), "Looking initially at operating range I remote from full load, <b><i>the desired output at a lower specific fuel consumption is able to be achieved after upshifting into the next higher gear</i></b>, at an operating point that lies to the left of operating range I in the diagram of Figure 1. <b><i>Accordingly, the device of the present invention generates a signal that asks the operator, i.e., normally the driver, to shift to a higher gear, which is indicated in Figure 1 by the upward pointing arrow within operating range I.</i></b>"</p> <p>E.g., pages 7 to 8 (English translation), "The two control circuits 2 and 3 are selectively closed by engine-speed dependent change-over switch 6, to which a signal that corresponds to the individual engine speed <math>n</math> is forwarded and which is developed in such a way that <b><i>at engine speeds that are greater than predefined engine speed <math>n_1</math> (see Figure 1), its shift lever pivots upwardly in Figure 2, but at engine speeds that are smaller than predefined engine speed <math>n_2</math>, it pivots in the downward direction from a neutral center position</i></b>, which it therefore assumes when engine speed values between <math>n_1</math> and <math>n_2</math> are present."</p> <p>E.g., Figure 1:</p>

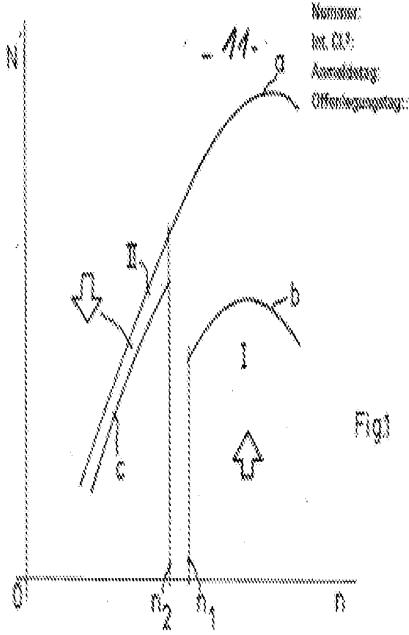
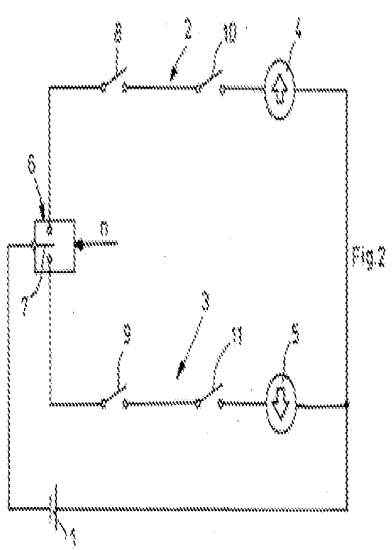
Limitation of '781 Patent Claim 7	Automotive Electronics Handbook (Jurgen)	German Patent Application Publication No. 29 26 070 (Volkswagen '070)
		 <p>Nummer: Int. Cl.: Abkürzung: Offenlegungstag:</p> <p>Fig.1</p> <p>E.g., Figure 2:</p>  <p>Fig.2</p>
said processor subsystem	E.g., page 12.4, "During coasting and braking, fuel consumption	E.g., pages 6 to 7 (English translation), "Looking initially at operating

Limitation of '781 Patent Claim 7	Automotive Electronics Handbook (Jurgen)	German Patent Application Publication No. 29 26 070 (Volkswagen '070)
<p>determining, based upon data received from said plurality of sensors, when to activate said fuel overinjection circuit and when to activate said downshift notification circuit.</p>	<p>can be further reduced by shutting off the fuel until the engine speed decreases to slightly higher than the set idle speed. <i>The ECU determines when fuel shutoff can occur by evaluating the throttle position, engine RPM, and vehicle speed.</i></p> <p>E.g., page 12.14, "Using the inputs of engine RPM and vehicle speed to the electronic control unit, thresholds can be established for limiting these variables with fuel cutoff. <i>When the maximum speed is achieved, the fuel injectors are shut off.</i> When the speed decreases below the threshold, fuel injection resumes."</p> <p>E.g., pages 13.7 to 13.9, "<i>The basic functions of the transmission control are the shift point control, the lockup control, engine torque control during shifting, related safety functions, and diagnostic functions for vehicle service.</i>"</p> <p>E.g., page 13.9, "The basic shift point control uses shift maps, which are defined in data in the unit memory. These shift maps are selectable over a wide range. <i>The shift point limitations are made, on the one hand, by the highest admissible engine speed for each application and, on the other hand, by the lowest engine speed that is practical for driving comfort and noise emission. The inputs of the shift point determination are the throttle position, the accelerator pedal position, and the vehicle speed (determined by the transmission output speed).</i>"</p>	<p>range I remote from full load, the desired output at a lower specific fuel consumption is able to be achieved after upshifting into the next higher gear, at an operating point that lies to the left of operating range I in the diagram of Figure 1. <i>Accordingly, the device of the present invention generates a signal that asks the operator, i.e., normally the driver, to shift to a higher gear, which is indicated in Figure 1 by the upward pointing arrow within operating range I.</i>"</p> <p>E.g., pages 7 to 8 (English translation), "The two control circuits 2 and 3 are selectively closed by engine-speed dependent change-over switch 6, to which a signal that corresponds to the individual engine speed <math>n</math> is forwarded and which is developed in such a way that <i>at engine speeds that are greater than predefined engine speed <math>n_1</math> (see Figure 1), its shift lever pivots upwardly in Figure 2, but at engine speeds that are smaller than predefined engine speed <math>n_2</math>, it pivots in the downward direction from a neutral center position, which it therefore assumes when engine speed values between <math>n_1</math> and <math>n_2</math> are present.</i>"</p> <p>E.g., page 7 (English translation), "<i>When the operating point lies in operating range II, the device according to the present invention generates a signal that asks the driver to downshift, which is indicated by the downward pointing arrow at operating range II in Figure 1.</i>"</p> <p>E.g., page 9 (English translation), "It is useful if in addition to this device, <i>a display of the route-specific fuel consumption</i> is provided in a vehicle. Such display devices are known per se; they generally utilize the <i>injection manifold vacuum</i> as a measure of fuel consumption."</p>

Limitation of '781 Patent Claim 13	Automotive Electronics Handbook (Jurgen)	German Patent Application Publication No. 29 26 070 (Volkswagen '070)
<p>13. Apparatus for optimizing operation of a vehicle, comprising:</p>	<p>E.g., page 12.1, “The electronic engine control system consists of sensing devices which continuously measure the operating conditions of the engine, <i>an electronic control unit (ECU) which evaluates the sensor inputs using data tables and calculations and determines the output to the actuating devices</i>, and actuating devices which are commanded by the ECU to perform an action in response to the sensor inputs.</p> <p>The motive for using an electronic engine control system is to provide the needed accuracy and adaptability in order to minimize exhaust emissions and fuel consumption, <i>provide optimal driveability for all operating conditions</i>, minimize evaporative emissions, and provide system diagnosis when malfunctions occur.”</p>	<p>E.g., page 5 (English translation), “The present invention is based on the objective of providing <i>a device that assists the operator of the internal combustion engine equipped with a conventional transmission</i>, i.e., the driver of a motor vehicle, for example, in setting an operating point of the engine that is advantageous in terms of consumption, by way of gear shift operations.”</p>
<p>a plurality of sensors coupled to a vehicle having an engine, said plurality of sensors, which collectively monitor operation of said vehicle, including a road speed sensor, an engine speed sensor, a manifold pressure sensor and a throttle position sensor;</p>	<p>E.g., page 7.6, “There are several applications for rotational speed sensing. <i>First it is necessary to monitor engine speed</i>. This information is used for transmission control, engine control, cruise control, and possibly for a tachometer. Electronics and electronic sensing in the automobile were brought about by the need for higher efficiency engines, better fuel economy, increased power and performance, and lower emissions. Second, <i>wheel speed sensing is required</i> for use in transmissions, cruise control, speedometers, antilock brake systems (ABS), traction control (ASR), variable ratio power steering assist, four-wheel steering, and possibly in inertial navigation and air bag deployment applications.”</p> <p>E.g., page 7.8, “In electronic transmission applications, <i>information from the road and engine speed sensors</i>, as well as torque data and throttle position are required for the MCU to select the optimum gear ratio.”</p> <p>E.g., page 2.5, “Automotive specification and testing guidelines have been developed and published by the Society of Automotive Engineers (SAE) specifically for <i>manifold absolute pressure (MAP) sensors</i>.”</p>	<p>E.g., page 6 (English translation), “As can be seen when viewing Figure 1 to begin with, output N of the engine has been plotted across engine speed n. a is the curve of the output at full load, b is a line that represents a constant setting of the output control element, i.e., a line that represents a constant <i>throttle valve angle</i> in a carburetor engine. As a measure thereof, in addition to the <i>throttle valve angle</i> itself, it is also possible to use the <i>induction manifold vacuum</i>. . . . The operating ranges I and II are further delimited by <i>engine speed</i> values <math>n_1</math> or <math>n_2</math>, the first of which usually lies between approximately 20 to 50% of the maximum engine speed, and the second usually lies between approximately 40 and 70% of the maximum engine speed.”</p> <p>E.g., page 8 (English translation), “<i>The engine speed signal is obtained with the aid of known sensor systems</i>, which therefore need not be described in further detail here.”</p> <p>E.g., page 9 (English translation), “It is useful if in addition to this device, a display of the route-specific fuel consumption is provided in a vehicle. Such display devices are known per se; they generally utilize the <i>injection manifold vacuum</i> as a measure of fuel consumption.”</p>

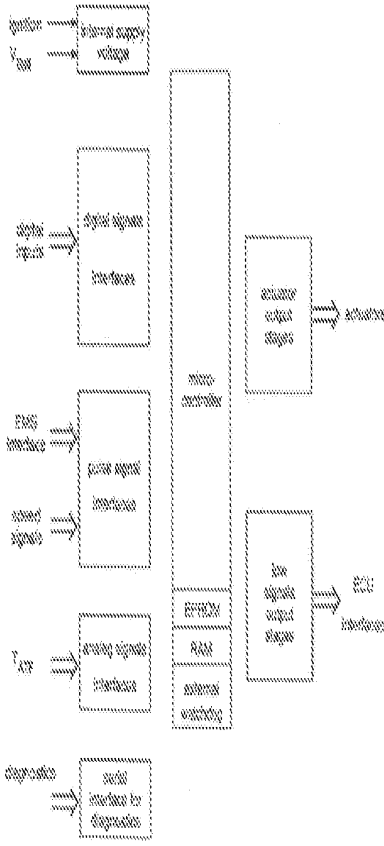
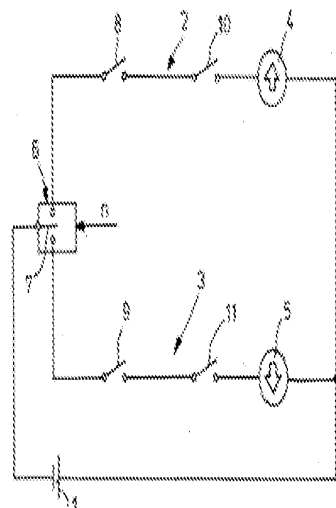

Limitation of '781 Patent Claim 13	Automotive Electronics Handbook (Jurgen)	German Patent Application Publication No. 29 26 070 (Volkswagen '070)
	<p>E.g., page 2.7, "Manifold absolute pressure (MAP) is used as an input to fuel and ignition control in internal combustion engine control systems. <i>The speed-density system that uses the MAP sensor</i> has been preferred over mass air flow (MAF) control because it's less expensive, but stricter emission standards are causing more manufacturers to use mass air flow for future models."</p> <p>E.g., page 12.18, "To control the idle speed, the ECU uses inputs from the <i>throttle position sensor</i>, air conditioning, automatic transmission, power steering, charging system, engine RPM, and vehicle speed."</p> <p>E.g., page 12.21, "The electronic injection unit also houses the <i>throttle position sensor</i> and, in some cases, an inlet air temperature sensor which provides operating condition information to the ECU."</p>	
<p>a processor subsystem, coupled to each one of said plurality of sensors, to receive data therefrom;</p>	<p>E.g., page 12.1, "The electronic engine control system consists of <i>sensing devices which continuously measure the operating conditions of the engine, an electronic control unit (ECU) which evaluates the sensor inputs</i> using data tables and calculations and determines the output to the actuating devices, and actuating devices which are commanded by the ECU to perform an action in response to the sensor inputs."</p> <p>E.g., page 22.6, "During the entire operating time of the vehicle, <i>the ECUs are constantly supervising the sensors they are connected to.</i>"</p> <p>E.g., page 13.4, "On the functional side, the hardware configuration can be divided into power supply, input signal transfer circuits, output stages, and <i>microcontroller</i>, including peripheral components and monitoring and safety circuits (Fig. 13.1)."</p> <p>E.g., Figure 13.1:</p>	<p>E.g., pages 7 to 8 (English translation), "<i>The two control circuits 2 and 3 are selectively closed by engine-speed dependent change-over switch 6, to which a signal that corresponds to the individual engine speed <math>n</math> is forwarded</i> and which is developed in such a way that at engine speeds that are greater than predefined engine speed <math>n_1</math> (see Figure 1), its shift lever pivots upwardly in Figure 2, but at engine speeds that are smaller than predefined engine speed <math>n_2</math>, it pivots in the downward direction from a neutral center position, which it therefore assumes when engine speed values between <math>n_1</math> and <math>n_2</math> are present."</p> <p>E.g., Figure 2:</p>

Limitation of '781 Patent Claim 13	Automotive Electronics Handbook (Jurgen)	German Patent Application Publication No. 29 26 070 (Volkswagen '070)
	 <p>FIG. 2 REF. 13.3 Overview of hardware parts</p> <p>E.g., page 14.3, "The speed sensor is one of the most critical parts in the system, because the <i>microcontroller calculates the vehicle speed from the speed sensor's signal</i> to within 1/32 m/h."</p>	 <p>Fig. 2</p>
<p>a memory subsystem, coupled to said processor subsystem, said memory subsystem storing therein a manifold pressure set point, an engine speed set point and present and prior levels for each one of said plurality of sensors;</p>	<p>E.g., page 13.5, "The calculators inside the control units are usually microcontrollers. . . . <i>The memory devices for program and data are usually EPROMS.</i> Their storage capacity is, in present applications, up to 64 Kbytes. Future applications will necessitate storage sizes up to 128 Kbytes. The failure storages for diagnostics and the storage for adaptive data are in conventional applications, battery voltage-supplied RAMs. These are increasingly being replaced by EEPROMs."</p>	<p>E.g., page 6 (English translation), "As can be seen when viewing Figure 1 to begin with, <i>output N of the engine has been plotted across engine speed n.</i>"</p> <p>E.g., page 6 (English translation), "<i>The numerical values of the limits of the two operating ranges I and II are of course dependent on the individual situation.</i> In general, it can be said that these two operating ranges lie in such a way that by shift operations, it is possible to achieve operating points in the</p>

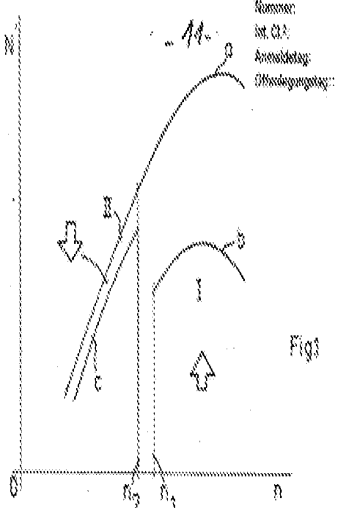
Limitation of '781 Patent Claim 13	Automotive Electronics Handbook (Jurgen)	German Patent Application Publication No. 29 26 070 (Volkswagen '070)
	<p>E.g., page 12.9, "A subsystem of the fuel control system is lambda closed-loop control. . . .</p> <p>[T]he engine control unit uses an anticipatory control strategy that uses engine load and RPM to determine the approximate fuel requirement. <i>The engine load information is provided by the manifold pressure sensor for speed density systems and by the air meter for air flow and air mass measurement systems and by the throttle valve position sensor. The engine control unit contains data tables for combinations of load and RPM.</i> This allows for rapid response to changes in operating conditions. The lambda sensor still provides the feedback correction for each load/RPM point. . . .</p> <p>[T]he electronic control unit has a feature for adapting changes in the fuel required for the load/RPM points. <i>At each load/RPM point, the lambda sensor continuously provides information that allows the system to adjust the fuel to the commanded A/F ratio. The corrected information is stored in RAM (random access memory) so that the next time the engine reaches that operating point (load/RPM), the anticipatory value will require less correction. These values remain stored in the electronic control unit even after the engine is shut off.</i> Only if power to the electronic control unit is disrupted (i.e., due to a dead battery), will the correction be lost. In that case, the electronic control unit will revert back to the original production values that are written in ROM (read-only memory)."</p> <p>E.g., page 14.2, "Other safety-related items include <i>program code to detect abnormal operating conditions and preserving into memory the data points associated with the abnormal condition for later diagnostics.</i> Abnormal conditions, for example, could be an intermittent vehicle speed sensor, or erratic driver switch signals."</p> <p>E.g., pages 22.2 to 22.3, "The most important test points of control units and sensors are tied to a diagnostic connector which is plugged into the measuring instrument with a corresponding</p>	<p>output/engine speed diagram that are more favorable in terms of fuel consumption."</p> <p>E.g., page 8 (English translation), "<i>Furthermore, to define the two operating ranges I and II, load-dependent switches 8 and 9 are provided in control circuits 2 and 3 in Figure 2, the first of which is closed only below the line denoted by b in Figure 1, and switch 9 is closed only above the line denoted by c in Figure 1.</i>"</p> <p>E.g., Figure 1:</p> 

Limitation of '781 Patent Claim 13	Automotive Electronics Handbook (Jurgen)	German Patent Application Publication No. 29 26 070 (Volkswagen '070)
	<p>adapter for the respective vehicle. . . .</p> <p><i>Modern electronics in vehicles support diagnosis by comparing the registered actual value with the internally stored nominal values with the help of control units and their self-diagnosis, thus detecting faults.</i></p>	
<p>a fuel overinjection notification circuit coupled to said processor subsystem, said fuel overinjection notification circuit issuing a notification that excessive fuel is being supplied to said engine of said vehicle;</p>	<p>E.g., page 12.22, "During an acceleration transition, the ECU adds a correction factor (an increase) to the commanded injector pulse width. The sudden increase in air results in a lean mixture which must be corrected swiftly to obtain good transitional response. <i>During a deceleration transition, the fuel can be shut off by simply not providing a pulse width signal to the injector to minimize exhaust emissions and fuel consumption.</i>"</p> <p>E.g., page 12.4, "During coasting and braking, fuel consumption can be further reduced by shutting off the fuel until the engine speed decreases to slightly higher than the set idle speed. <i>The ECU determines when fuel shutoff can occur by evaluating the throttle position, engine RPM, and vehicle speed.</i>"</p> <p>E.g., page 12.14, "Using the inputs of engine RPM and vehicle speed to the electronic control unit, thresholds can be established for limiting these variables with fuel cutoff. <i>When the maximum speed is achieved, the fuel injectors are shut off.</i> When the speed decreases below the threshold, fuel injection resumes."</p> <p>E.g., page 12.17, "<i>During transition to fuel cutoff, the ignition timing is retarded from its current setting to reduce engine torque and to assist in engine braking. The fuel is then shut off.</i> During the transition, the throttle bypass valve or the main throttle valve may remain open for a short period to allow fresh air to oxidize the remaining unburned HC and CO to further reduce exhaust emissions. During development of the fuel cutoff strategy, the advantage of reduced emission effects and catalyst temperature control must be balanced against driveability requirements. The use of fuel cutoff may change the perceived amount of engine braking felt by the driver. In addition, care must be taken to avoid a 'bump' feel when entering the fuel cutoff mode, due to the change in</p>	<p>E.g., page 9 (English translation), "It is useful if in addition to this device, <i>a display of the route-specific fuel consumption is provided in a vehicle.</i> Such display devices are known per se; they generally utilize the injection manifold vacuum as a measure of fuel consumption."</p>

Limitation of '781 Patent Claim 13	Automotive Electronics Handbook (Jurgen)	German Patent Application Publication No. 29 26 070 (Volkswagen '070)
	torque.”	
<p>an upshift notification circuit coupled to said processor subsystem, said upshift notification circuit issuing a notification that said engine of said vehicle is being operated at an excessive engine speed;</p>	<p>E.g., page 13.7 to 13.9, “<i>The basic functions of the transmission control are the shift point control, the lockup control, engine torque control during shifting, related safety functions, and diagnostic functions for vehicle service.</i>”</p> <p>E.g., page 13.9, “The basic shift point control uses shift maps, which are defined in data in the unit memory. These shift maps are selectable over a wide range. <i>The shift point limitations are made, on the one hand, by the highest admissible engine speed for each application and, on the other hand, by the lowest engine speed that is practical for driving comfort and noise emission. The inputs of the shift point determination are the throttle position, the accelerator pedal position, and the vehicle speed (determined by the transmission output speed).</i>”</p> <p>E.g., page 13.14, “In addition to these functions, <i>different shift maps can be implemented into the data field of the TCU [Transmission Control Unit].</i> For example, it is possible to have one shift map for low fuel consumption, which has shift points in the range of the best efficiency of the engine, and additionally to have another map for power operation, where the shift points are placed at points of highest engine output power.”</p>	<p>E.g., pages 6 to 7 (English translation), “Looking initially at operating range I remote from full load, <i>the desired output at a lower specific fuel consumption is able to be achieved after upshifting into the next higher gear</i>, at an operating point that lies to the left of operating range I in the diagram of Figure 1. <i>Accordingly, the device of the present invention generates a signal that asks the operator, i.e., normally the driver, to shift to a higher gear, which is indicated in Figure 1 by the upward pointing arrow within operating range I.</i>”</p> <p>E.g., pages 7 to 8 (English translation), “The two control circuits 2 and 3 are selectively closed by engine-speed dependent change-over switch 6, to which a signal that corresponds to the individual engine speed <math>n</math> is forwarded and which is developed in such a way that <i>at engine speeds that are greater than predefined engine speed <math>n_1</math> (see Figure 1), its shift lever pivots upwardly in Figure 2, but at engine speeds that are smaller than predefined engine speed <math>n_2</math>, it pivots in the downward direction from a neutral center position</i>, which it therefore assumes when engine speed values between <math>n_1</math> and <math>n_2</math> are present.”</p> <p>E.g., Figure 1:</p>

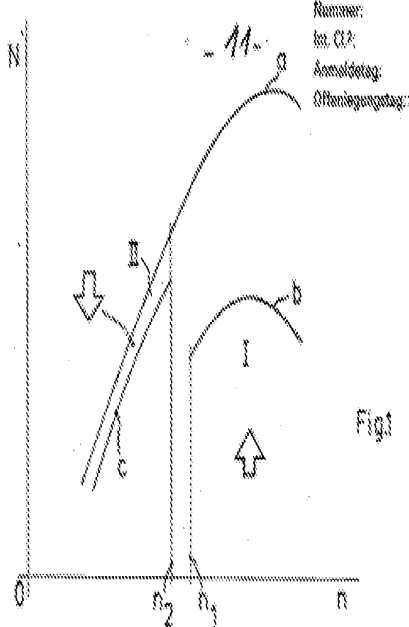
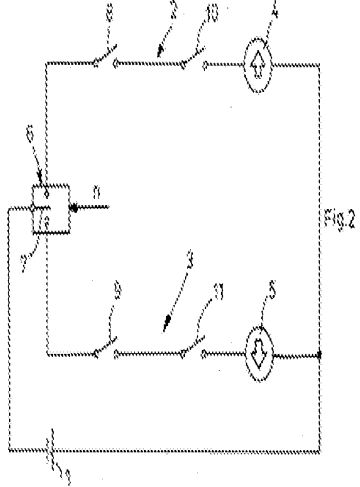
Limitation of '781 Patent Claim 13	Automotive Electronics Handbook (Jurgen)	German Patent Application Publication No. 29 26 070 (Volkswagen '070)
		 <p>Rummer: Int. Cl. P: Anmeldetag: Offenlegungstag:</p> <p>Fig 1</p> <p>E.g., Figure 2:</p>  <p>Fig 2</p>
<p>a downshift notification circuit coupled to said processor subsystem, said downshift notification circuit</p>	<p>E.g., page 13.7 to 13.9, "<i>The basic functions of the transmission control are the shift point control</i>, the lockup control, engine torque control during shifting, related safety functions, and</p>	<p>E.g., pages 6 to 7 (English translation), "Looking initially at operating range I remote from full load, <i>the desired output at a lower specific fuel consumption is able to be achieved after</i></p>

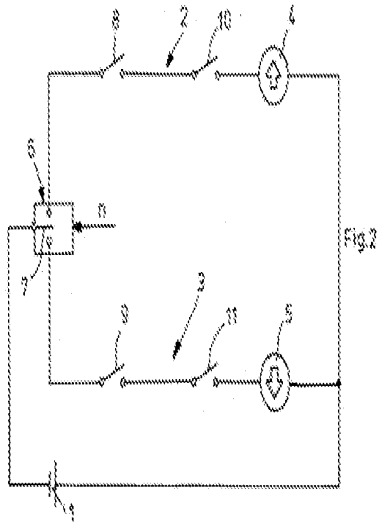

Limitation of '781 Patent Claim 13	Automotive Electronics Handbook (Jurgen)	German Patent Application Publication No. 29 26 070 (Volkswagen '070)
		<p>E.g., Figure 2:</p>  <p style="text-align: right;">Fig. 2</p>
<p>said processor subsystem determining, based upon data received from said plurality of sensors, when to activate said fuel overinjection circuit, said upshift notification circuit, and said downshift notification circuit.</p>	<p>E.g., page 12.4, "During coasting and braking, fuel consumption can be further reduced by shutting off the fuel until the engine speed decreases to slightly higher than the set idle speed. <i>The ECU determines when fuel shutoff can occur by evaluating the throttle position, engine RPM, and vehicle speed.</i>"</p> <p>E.g., page 12.14, "Using the inputs of engine RPM and vehicle speed to the electronic control unit, thresholds can be established for limiting these variables with fuel cutoff. <i>When the maximum speed is achieved, the fuel injectors are shut off.</i> When the speed decreases below the threshold, fuel injection resumes."</p> <p>E.g., page 13.7 to 13.9, "<i>The basic functions of the transmission control are the shift point control, the lockup control, engine torque control during shifting, related safety functions, and diagnostic functions for vehicle service.</i>"</p> <p>E.g., page 13.9, "The basic shift point control uses shift maps, which are defined in data in the unit memory. These shift maps are selectable over a wide range. <i>The shift point limitations are made,</i></p>	<p>E.g., pages 6 to 7 (English translation), "Looking initially at operating range I remote from full load, the desired output at a lower specific fuel consumption is able to be achieved after upshifting into the next higher gear, at an operating point that lies to the left of operating range I in the diagram of Figure 1. <i>Accordingly, the device of the present invention generates a signal that asks the operator, i.e., normally the driver, to shift to a higher gear, which is indicated in Figure 1 by the upward pointing arrow within operating range I.</i>"</p> <p>E.g., pages 7 to 8 (English translation), "The two control circuits 2 and 3 are selectively closed by engine-speed dependent change-over switch 6, to which a signal that corresponds to the individual engine speed <math>n</math> is forwarded and which is developed in such a way that <i>at engine speeds that are greater than predefined engine speed <math>n_1</math> (see Figure 1), its shift lever pivots upwardly in Figure 2, but at engine speeds that are smaller than predefined engine speed <math>n_2</math>, it pivots in the downward direction from a neutral center position, which it therefore assumes when engine speed values between <math>n_1</math> and <math>n_2</math> are present.</i>"</p>



Limitation of '781 Patent Claim 13	Automotive Electronics Handbook (Jurgen)	German Patent Application Publication No. 29 26 070 (Volkswagen '070)
	<p>on the one hand, by the highest admissible engine speed for each application and, on the other hand, <i>by the lowest engine speed that is practical for driving comfort and noise emission. The inputs of the shift point determination are the throttle position, the accelerator pedal position, and the vehicle speed</i> (determined by the transmission output speed)."</p>	<p>E.g., page 7 (English translation), "<i>When the operating point lies in operating range II, the device according to the present invention generates a signal that asks the driver to downshift, which is indicated by the downward pointing arrow at operating range II in Figure 1.</i>"</p> <p>E.g., page 9 (English translation), "It is useful if in addition to this device, <i>a display of the route-specific fuel consumption</i> is provided in a vehicle. Such display devices are known per se; they generally utilize the <i>injection manifold vacuum</i> as a measure of fuel consumption."</p>

4. Claims 17–23 and 26 are Obvious in View of the Combination of Jurgén, Toyota '599, and Davidian

Limitation of '781 Patent Claim 17	Automotive Electronics Handbook (Jurgén)	U.S. Patent No. 4,559,599 (Toyota '599)	U.S. Patent No. 5,357,438 (Davidian)
<p>17. Apparatus for optimizing operation of a vehicle, comprising:</p>	<p>E.g., page 12.1, “The electronic engine control system consists of sensing devices which continuously measure the operating conditions of the engine, <i>an electronic control unit (ECU) which evaluates the sensor inputs using data tables and calculations and determines the output to the actuating devices</i>, and actuating devices which are commanded by the ECU to perform an action in response to the sensor inputs.</p> <p>The motive for using an electronic engine control system is to provide the needed accuracy and adaptability in order to minimize exhaust emissions and fuel consumption, <i>provide optimal driveability for all operating conditions</i>, minimize evaporative emissions, and provide system diagnosis when malfunctions occur.”</p>	<p>E.g., Abstract, “<i>A shift indication apparatus</i> having an engine rotation sensor, a throttle valve sensor, and a shift position sensor, a microcomputer having a ROM and RAM for storing data corresponding to the engine speed, throttle valve openings, and the shift positions therein, and an indicator for indicating preferable shift positions to be performed by a driver in which a torque data map and a fuel consumption rate data map have stored in the ROM for calculating various torque and fuel consumption rates <i>so as to obtain preferable shift positions relating to optimum fuel consumption rate in accordance with said data detected. With this construction, it becomes possible for a driver to run his car in accordance with the indications of the shift operation on the indicator so as to enable the economical running of the car to be realized.</i>”</p>	<p>E.g., col. 1, lines 1 to 2, “The present invention relates to <i>an anti-collision system for vehicles.</i>”</p>
<p>a radar detector, said radar detector determining a distance separating a vehicle having an engine and an object in front of said vehicle;</p>	<p>E.g., page 7.23, “Ultrasonics, infrared, laser, and <i>microwaves (radar) can be used in the detection of objects behind vehicles and in the blind areas.</i>”</p>		<p>E.g., col. 4, lines 52 to 66, “<i>Vehicle 2 further includes a front space sensor 8 for sensing the space in front of the vehicle, such as the presence of another vehicle, a corresponding rear space sensor 10, and a pair of side sensors 11.</i> All the space sensors are in the form of pulse (e.g., ultrasonic) transmitters and receivers, for determining the distance of the vehicle from an object, e.g., another vehicle, at front or rear. Space sensors may also be provided at the sides of the vehicle. Vehicle 2 is further equipped with a speed sensor 12 which may sense the speed of the vehicle in any known manner, for example using the speed measuring system of the vehicle itself, or a speed measuring system independent of the vehicle, e.g.,</p>

Limitation of '781 Patent Claim 17	Automotive Electronics Handbook (Jurgen)	U.S. Patent No. 4,559,599 (Toyota '599)	U.S. Patent No. 5,357,438 (Davidian)
			<p>an acceleration sensor, or by calculations based on the Doppler effect, etc.”</p> <p>E.g., col. 10, lines 17 to 26, “FIG. 7 is a circuit diagram of the microcomputer 4 and the other components of the electrical system. The microprocessor is indicated by block 100, its power supply by block 102, and its watchdog circuit by block 104. <i>It includes a transmitter 106 and a receiver 108 for transmitting and receiving the pulses (e.g., RF, ultrasound, laser, IR, etc.) in the front space sensor 8 and the rear space sensor 10 for measuring the distance of the vehicle from objects in front of, and to the rear, of the vehicle, respectively.</i>”</p> <p>E.g., col. 10, lines 38 to 50, “As indicated earlier, the distance of the vehicle from an object is determined by the front space sensor 8 with respect to objects in front of the vehicle, and by the rear space sensor 10 with respect to objects at the rear of the vehicle. Each of these space sensors may be of known construction, including a transmitter as indicated at 106 in FIG. 7, and a receiver as indicated at 108. <i>Thus, pulses are continuously transmitted by each transmitter, and the echoes from the objects in front of or to the rear of the vehicle are received by the respective receiver. The computer then measures the round-trip time from the pulse transmission to the echo reception in order to determine the distance of the vehicle from the object.</i>”</p>
at least one sensor coupled to said vehicle for monitoring	E.g., page 7.6, “There are several applications for rotational speed sensing. <i>First it is necessary to monitor engine speed.</i> This information is used for transmission control, engine control, cruise	E.g., col. 2, lines 23 to 36, “Referring to FIG. 1, the shift indication apparatus with a manual transmission according to the present invention comprises <i>an engine speed sensor 1 for</i>	E.g., col. 4, lines 60 to 66, “Vehicle 2 is further equipped with <i>a speed sensor 12 which may sense the speed of the vehicle in any known manner,</i> for example using the speed measuring system of the

Limitation of '781 Patent Claim 17	Automotive Electronics Handbook (Jurgen)	U.S. Patent No. 4,559,599 (Toyota '599)	U.S. Patent No. 5,357,438 (Davidian)
<p>operation thereof, said at least one sensor including a road speed sensor, a manifold pressure sensor, a throttle position sensor and an engine speed sensor;</p>	<p>control, and possibly for a tachometer. Electronics and electronic sensing in the automobile were brought about by the need for higher efficiency engines, better fuel economy, increased power and performance, and lower emissions. Second, <i>wheel speed sensing is required</i> for use in transmissions, cruise control, speedometers, antilock brake systems (ABS), traction control (ASR), variable ratio power steering assist, four-wheel steering, and possibly in inertial navigation and air bag deployment applications.”</p> <p>E.g., page 7.8, “In electronic transmission applications, <i>information from the road and engine speed sensors</i>, as well as torque data and throttle position are required for the MCU to select the optimum gear ratio.”</p> <p>E.g., page 2.5, “Automotive specification and testing guidelines have been developed and published by the Society of Automotive Engineers (SAE) specifically for <i>manifold absolute pressure (MAP) sensors</i>.”</p> <p>E.g., page 2.7, “Manifold absolute pressure (MAP) is used as an input to fuel and ignition control in internal combustion engine control systems. <i>The speed-density system that uses the MAP sensor</i> has been preferred over mass air flow (MAF) control because it's less expensive, but stricter emission standards are causing more manufacturers to use mass air flow for future models.”</p> <p>E.g., page 12.18, “To control the idle speed, the</p>	<p><i>detecting the engine speed and for producing pulse signals of a frequency proportional to the engine speed</i>, a shift position sensor 2 for detecting the shift positions of the transmission, <i>a throttle sensor 3 for detecting the opening degree of the throttle valve by means of, for instance, a potentiometer</i>, an A/D converter 4 for converting analog signals from the throttle valve sensor 3 into digital signals, a microcomputer 5 for performing various calculations in accordance with the different signals from the sensors, and an indicator 10 for indicating the result of the calculations.”</p> <p>E.g., col. 2, lines 43 to 48, “<i>The engine speed sensor 1</i> is mounted in a distributor (not shown) and the output of the sensor is connected to the input of the I/O port 6 so as to transmit the output pulses to the microcomputer 5 through the I/O port 6 and to store the data corresponding to the engine speed into the RAM 9.”</p> <p>E.g., col. 2, lines 52 to 59, “Similarly, the output of <i>the throttle sensor 3</i> is connected through the A/D converter 4 to the input of the I/O port 6 so as to transmit the output signals thereof to the microcomputer 5 through the A/D converter 4 and to store the data corresponding to the throttle value opening into the RAM 9 after converting from the analog signals into the digital signals.”</p> <p>E.g., FIG. 1:</p>	<p>vehicle itself, or a speed measuring system independent of the vehicle, e.g., an acceleration sensor, or by calculations based on the Doppler effect, etc.”</p>

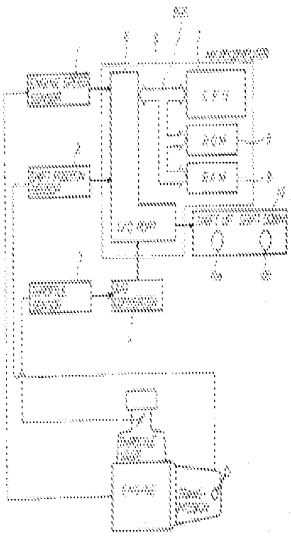
Limitation of '781 Patent Claim 17	Automotive Electronics Handbook (Jurgen)	U.S. Patent No. 4,559,599 (Toyota '599)	U.S. Patent No. 5,357,438 (Davidian)
	<p>ECU uses inputs from the <i>throttle position sensor</i>, air conditioning, automatic transmission, power steering, charging system, engine RPM, and vehicle speed.”</p> <p>E.g., page 12.21, “The electronic injection unit also houses the <i>throttle position sensor</i> and, in some cases, an inlet air temperature sensor which provides operating condition information to the ECU.”</p>		
<p>a processor subsystem, coupled to said radar detector and said at least one sensor, to receive data therefrom;</p>	<p>E.g., page 12.1, “The electronic engine control system consists of <i>sensing devices which continuously measure the operating conditions of the engine, an electronic control unit (ECU) which evaluates the sensor inputs</i> using data tables and calculations and determines the output to the actuating devices, and actuating devices which are commanded by the ECU to perform an action in response to the sensor inputs.”</p> <p>E.g., page 22.6, “During the entire operating time of the vehicle, <i>the ECUs are constantly supervising the sensors they are connected to.</i>”</p> <p>E.g., page 13.4, “On the functional side, the hardware configuration can be divided into power supply, input signal transfer circuits, output stages, and <i>microcontroller</i>, including peripheral components and monitoring and safety circuits (Fig. 13.1).”</p>	<p>E.g., col. 2, lines 23 to 36, “Referring to FIG. 1, the shift indication apparatus with a manual transmission according to the present invention comprises an engine speed sensor 1 for detecting the engine speed and for producing pulse signals of a frequency proportional to the engine speed, a shift position sensor 2 for detecting the shift positions of the transmission, a throttle sensor 3 for detecting the opening degree of the throttle valve by means of, for instance, a potentiometer, an A/D converter 4 for converting analog signals from the throttle valve sensor 3 into digital signals, a <i>microcomputer 5 for performing various calculations in accordance with the different signals from the sensors</i>, and an indicator 10 for indicating the result of the calculations.”</p> <p>E.g., col. 2, lines 37 to 42, “<i>The microcomputer 5</i> further comprises an input/output port (I/O port) 6, a <i>central processing unit (CPU) 7</i>, a read</p>	<p>E.g., col. 8, lines 29 to 43, “<i>FIGS. 6a, 6b, are a block diagram illustrating the microcomputer 4 and its inputs and outputs described earlier which enable it to continuously monitor the operation of the vehicle</i> and to actuate first a Safety alarm, and then a Collision alarm whenever the vehicle may enter a danger-of-collision situation according to the various preset parameters and automatic parameters introduced into the computer.</p> <p><i>The microcomputer 4 as illustrated in FIGS. 6a, 6b is divided into various functional modules, as follows: a calculation module 90, which receives data concerning the various parameters briefly described above and as will be described more particularly below to enable it to make the necessary computations for actuating the Safety alarm and the Collision alarm.</i>”</p> <p>E.g., col. 8, lines 58 to 60, “Thus, module 90 receives inputs from the front space sensor 8, the</p>

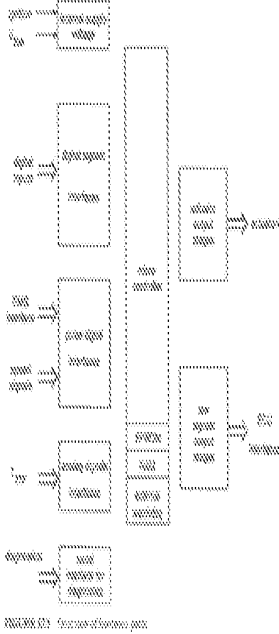
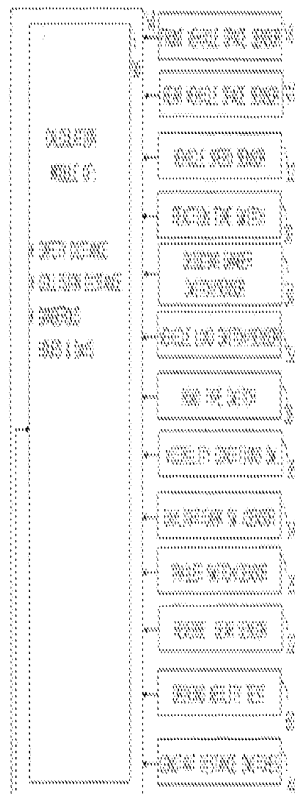
Limitation of '781 Patent Claim 17	Automotive Electronics Handbook (Jurgen)	U.S. Patent No. 4,559,599 (Toyota '599)	U.S. Patent No. 5,357,438 (Davidian)
	<p>E.g., Figure 13.1:</p>  <p>E.g., page 14.3, "The speed sensor is one of the most critical parts in the system, because the <i>microcontroller calculates the vehicle speed from the speed sensor's signal</i> to within 1/32 m/h."</p>	<p>only memory (ROM) 8, and a random access memory (RAM) 9. In the microcomputer 5, there is provided a bus BUS which communicates the I/O port 6 and the CPU 7, ROM 8, and RAM 9."</p> <p>E.g., col. 2, lines 43 to 48, "The engine speed sensor 1 is mounted in a distributor (not shown) and <i>the output of the sensor is connected to the input of the I/O port 6 so as to transmit the output pulses to the microcomputer 5</i> through the I/O port 6 and to store the data corresponding to the engine speed into the RAM 9."</p> <p>E.g., col. 2, lines 52 to 59, "Similarly, <i>the output of the throttle sensor 3 is connected through the A/D converter 4 to the input of the I/O port 6 so as to transmit the output signals thereof to the microcomputer 5</i> through the A/D converter 4 and to store the data corresponding to the throttle value opening into the RAM 9 after converting from the analog signals into the digital signals."</p>	<p>rear space sensor 10, and the vehicle speed sensor 12."</p> <p>E.g., Figure 6A:</p>  <p>FIG. 6A</p>
<p>a memory subsystem, coupled to said processor subsystem, said memory subsystem storing</p>	<p>E.g., page 13.5, "The calculators inside the control units are usually microcontrollers. . . . <i>The memory devices for program and data are usually EPROMS.</i> Their storage capacity is, in present applications, up to 64 Kbytes. Future applications will necessitate storage sizes up to 128 Kbytes. The failure storages for diagnostics</p>	<p>E.g., col. 2, lines 37 to 42, "The microcomputer 5 further comprises an input/output port (I/O port) 6, a central processing unit (CPU) 7, a <i>read only memory (ROM) 8, and a random access memory (RAM) 9.</i> In the microcomputer 5, there is provided a bus BUS which communicates the I/O port 6 and the CPU 7, <i>ROM 8, and RAM 9.</i>"</p>	<p>E.g., col. 9, lines 20 to 27, "<i>Computer module 90 also includes information about the vehicle braking distances as a function of speed. This is preferably in the form of a look-up table, for example, provided by the manufacturer for predetermined defined conditions concerning road type, skidding danger, vehicle load and tires</i></p>

Limitation of '781 Patent Claim 17	Automotive Electronics Handbook (Jurgen)	U.S. Patent No. 4,559,599 (Toyota '599)	U.S. Patent No. 5,357,438 (Davidian)
<p>a first vehicle speed/stopping distance table, a manifold pressure set point, an RPM set point, a present level for each one of said at least one sensor and a prior level for each one of said at least one sensor;</p>	<p>and the storage for adaptive data are in conventional applications, battery voltage-supplied RAMs. These are increasingly being replaced by EEPROMs.”</p> <p>E.g., page 12.9, “A subsystem of the fuel control system is lambda closed-loop control. . . .</p> <p>[T]he engine control unit uses an anticipatory control strategy that uses engine load and RPM to determine the approximate fuel requirement. <i>The engine load information is provided by the manifold pressure sensor for speed density systems and by the air meter for air flow and air mass measurement systems and by the throttle valve position sensor. The engine control unit contains data tables for combinations of load and RPM.</i> This allows for rapid response to changes in operating conditions. The lambda sensor still provides the feedback correction for each load/RPM point. . . .</p> <p>[T]he electronic control unit has a feature for adapting changes in the fuel required for the load/RPM points. <i>At each load/RPM point, the lambda sensor continuously provides information that allows the system to adjust the fuel to the commanded A/F ratio. The corrected information is stored in RAM (random access memory) so that the next time the engine reaches that operating point (load/RPM), the anticipatory value will require less correction. These values remain stored in the electronic control unit even after the engine is shut off.</i> Only if power to the electronic control unit is disrupted (i.e., due to a dead battery), will the correction be lost. In that case, the electronic</p>	<p>E.g., col. 3, lines 7 to 20, “<i>The torque data map indicative of torque curves T as shown in FIG. 2 has been stored in the ROM 8 in advance. The fuel consumption rate data map indicative of equal fuel consumption rate curves B as shown in FIG. 3 has been also stored in the ROM 8 in advance. In FIG. 2, each equal torque curve T was prepared by plotting and connecting equal torque points on the graph with respect to the engine speed vs. throttle valve opening.</i> In FIG. 3, each fuel consumption rate curve B was prepared by plotting and connecting equal fuel consumption rate points on a graph obtained in advance by experiment data with respect to the engine speed and the torques thus calculated.”</p> <p>E.g., col. 3, lines 44 to 61, “<i>In this case, as shown in FIG. 4, the operation of a main routine is started at a predetermined timing, e.g. periodical timing pulses from a timer (not shown) and the detection of the engine speed <math>N_e</math> from the sensor 1 is carried out and it is stored into the RAM 9 at the step 20. Then, the engine speed <math>N_e</math> is read from the RAM 9 and it is compared with a predetermined number <math>N</math> (=1000 rpm) to determine whether or not the <math>N_e</math> exceeds the value 1000 at the step 21.</i> If the result of the decision is YES, the next step 22 is executed. That is, in the step 22, the reading in of the opening of the throttle valve is performed through the throttle sensor 3 and the A/D converter 4. In the above case, if the result of the decision in step 21 is NO, the main routine is terminated by determining that the shift operation is not necessary and the engine speed <math>N_e</math> is read again at the predetermined timing and now the</p>	<p>pressure, and is stored in a ROM (read-only memory) of the microcomputer so that it can be changed periodically if necessary.”</p> <p>E.g., col. 12, line 59 to col 13, line 22, “The system then makes the computations illustrated (as an example) in block 162 to determine the stopping distance SD, which is equal to the reaction distance plus the braking distance multiplied by a stopping factor ST and a safety factor SF. <i>In the illustrated example, the stopping distance is the sum of the reaction distance and the braking distance. The reaction distance is the product of the reaction time, visibility condition, daylight condition, reaction factor and speed; and the braking distance is the product of the braking distance (as supplied by the manufacturer), road type, skidding danger, vehicle load and braking factor.</i> The stopping distance (SD) includes further safety factors, and determines when the safety alarm will be actuated to first alert the driver of an approaching collision danger.</p> <p><i>A determination is also made of the collision distance CD which is equal to the stopping distance SD divided by the collision safety factor CSF, e.g., 1.25 in the example illustrated above, such that should the distance between the vehicle and the object come within the collision distance CD, the collision alarm is then actuated.</i></p> <p>The foregoing calculations of stopping distance SD and collision distance CD with respect to objects at the front of the vehicle are also made with respect to objects at the rear of the vehicle, these calculations being RSD and RCD, respectively, also shown in block 162.</p>

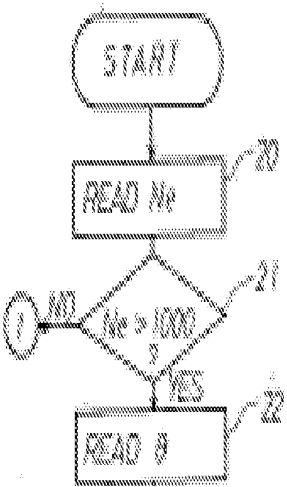
Limitation of '781 Patent Claim 17	Automotive Electronics Handbook (Jurgen)	U.S. Patent No. 4,559,599 (Toyota '599)	U.S. Patent No. 5,357,438 (Davidian)
	<p>control unit will revert back to the original production values that are written in ROM (read-only memory)."</p> <p>E.g., page 14.2, "Other safety-related items include <i>program code to detect abnormal operating conditions and preserving into memory the data points associated with the abnormal condition for later diagnostics.</i> Abnormal conditions, for example, could be an intermittent vehicle speed sensor, or erratic driver switch signals."</p> <p>E.g., pages 22.2 to 22.3, "The most important test points of control units and sensors are tied to a diagnostic connector which is plugged into the measuring instrument with a corresponding adapter for the respective vehicle. . . . <i>Modern electronics in vehicles support diagnosis by comparing the registered actual value with the internally stored nominal values</i> with the help of control units and their self-diagnosis, thus detecting faults."</p>	<p>operation returns to the step 20."</p> <p>E.g., Figure 4:</p>  <pre> graph TD     START([START]) --&gt; READ_Nc[READ Nc 20]     READ_Nc --&gt; DEC{Nc &gt; 1000 21}     DEC -- NO --&gt; START     DEC -- YES --&gt; READ_B[READ B 22] </pre>	<p>Whenever the distance between the vehicle and an object to the front of the vehicle or to the rear of the vehicle comes within the stopping distance SD and the collision distance CD, the system operates according to the deceleration alarm module 93, as indicated by block 164."</p>
<p>a vehicle proximity alarm circuit coupled to said processor subsystem, said vehicle proximity alarm circuit issuing an alarm that said vehicle is too close to said object;</p>	<p>E.g., page 7.6, "[W]heel speed sensing is required for use in transmissions, cruise control, speedometers, antilock brake systems (ABS), traction control (ASR), variable ratio power steering assist, four-wheel steering, and possibly in inertial navigation and air bag deployment applications. Linear speed sensing can be used to measure the ground speed. This measurement also has the possibly of use in ABS, ASR, and inertial navigation. <i>Similar types of sensors can be used in crash avoidance, proximity, and obstacle detection applications.</i>"</p>		<p>E.g., col. 3, lines 59 to 66, "The anti-collision system illustrated in FIGS. 1-14 is particularly useful for motor vehicles (passengers cars, buses, trucks) in order to <i>actuate an alarm when the vehicle is travelling at a distance behind another vehicle or in front of another</i>, which is equal to or less than a danger-of-collision distance computed by a computer such that if the front vehicle stops suddenly there is a danger of a rear-end collision."</p> <p>E.g., col. 4, lines 14 to 16, "In the system described below, <i>there are two alarms: a Collision alarm, which is actuated when the vehicle is determined</i></p>



Limitation of '781 Patent Claim 17	Automotive Electronics Handbook (Jurgen)	U.S. Patent No. 4,559,599 (Toyota '599)	U.S. Patent No. 5,357,438 (Davidian)
	<p>E.g., page 7.23, "Ultrasonics, infrared, laser, and microwaves (radar) can be used in the detection of objects behind vehicles and in the blind areas."</p>		<p><i>to be within the danger-of-collision distance; and a Safety alarm, which is actuated before the Collision alarm, at a distance greater than the danger-of-collision distance by a predetermined safety factor, e.g., 1.25."</i></p> <p>E.g., col. 6, lines 25 to 29, "Control panel 6 further includes a front distance display 46, in which are displayed the distance to the front vehicle (in region 46a), in which direction (by arrow 46b), and <i>whether or not there is a collision danger (region 46c).</i>"</p> <p>E.g., col. 6, lines 41 to 46, "Control panel 6 further includes a speaker 54 for producing an <i>audio alarm in the event of a collision danger, in addition to the visually-indicated alarms</i> of sections 46c and 48c of the displays 46 and 48."</p> <p>E.g., col. 8, lines 37 to 48, "The <i>microcomputer 4</i> as illustrated in FIGS. 6a, 6b is divided into various functional modules, as follows: ... <i>a deceleration alarm module 93, which controls the Safety alarm and Collision alarm on the control panel, ...</i>"</p> <p>E.g., Figs. 3 and 6B (ref. no. 46C)</p>
<p>a fuel overinjection circuit coupled to said processor subsystem, said fuel overinjection circuit issuing a notification that excessive fuel is</p>	<p>E.g., page 12.22, "During an acceleration transition, the ECU adds a correction factor (an increase) to the commanded injector pulse width. The sudden increase in air results in a lean mixture which must be corrected swiftly to obtain good transitional response. <i>During a deceleration transition, the fuel can be shut off by simply not providing a pulse width signal to the injector to minimize exhaust emissions and</i></p>		

Limitation of '781 Patent Claim 17	Automotive Electronics Handbook (Jurgen)	U.S. Patent No. 4,559,599 (Toyota '599)	U.S. Patent No. 5,357,438 (Davidian)
being supplied to said engine of said vehicle;	<p><i>fuel consumption.”</i></p> <p>E.g., page 12.4, “During coasting and braking, fuel consumption can be further reduced by shutting off the fuel until the engine speed decreases to slightly higher than the set idle speed. <i>The ECU determines when fuel shutoff can occur by evaluating the throttle position, engine RPM, and vehicle speed.</i>”</p> <p>E.g., page 12.14, “Using the inputs of engine RPM and vehicle speed to the electronic control unit, thresholds can be established for limiting these variables with fuel cutoff. <i>When the maximum speed is achieved, the fuel injectors are shut off.</i> When the speed decreases below the threshold, fuel injection resumes.”</p> <p>E.g., page 12.17, “<i>During transition to fuel cutoff, the ignition timing is retarded from its current setting to reduce engine torque and to assist in engine braking. The fuel is then shut off.</i> During the transition, the throttle bypass valve or the main throttle valve may remain open for a short period to allow fresh air to oxidize the remaining unburned HC and CO to further reduce exhaust emissions. During development of the fuel cutoff strategy, the advantage of reduced emission effects and catalyst temperature control must be balanced against driveability requirements. The use of fuel cutoff may change the perceived amount of engine braking felt by the driver. In addition, care must be taken to avoid a ‘bump’ feel when entering the fuel cutoff mode, due to the change in torque.”</p>		
an upshift	E.g., page 13.7 to 13.9, “ <i>The basic functions of</i>	E.g., col. 2, line 64 to col. 3, line 3, “ <i>The</i>	

Limitation of '781 Patent Claim 17	Automotive Electronics Handbook (Jurgen)	U.S. Patent No. 4,559,599 (Toyota '599)	U.S. Patent No. 5,357,438 (Davidian)
<p>notification circuit coupled to said processor subsystem, said upshift notification circuit issuing a notification that said engine of said vehicle is being operated at an excessive speed;</p>	<p><i>the transmission control are the shift point control</i>, the lockup control, engine torque control during shifting, related safety functions, and diagnostic functions for vehicle service.”</p> <p>E.g., page 13.9, “The basic shift point control uses shift maps, which are defined in data in the unit memory. These shift maps are selectable over a wide range. <i>The shift point limitations are made, on the one hand, by the highest admissible engine speed for each application</i> and, on the other hand, by the lowest engine speed that is practical for driving comfort and noise emission. <i>The inputs of the shift point determination are the throttle position, the accelerator pedal position, and the vehicle speed</i> (determined by the transmission output speed).”</p> <p>E.g., page 13.14, “In addition to these functions, <i>different shift maps can be implemented into the data field of the TCU [Transmission Control Unit]</i>. For example, it is possible to have one shift map for low fuel consumption, which has shift points in the range of the best efficiency of the engine, and additionally to have another map for power operation, where the shift points are placed at points of highest engine output power.”</p>	<p><i>indicator 10 includes a shift-up indicating lamp 10a and a shift-down indicating lamp 10b.</i></p> <p><i>The indicator 10 may be assembled by light emitting [sic] diodes (LED) so as to perform shift-up and shift-down indications by up and down directed arrow marks.</i> Alternatively, the indicator 10 may also be replaced with other voice combining circuit so as to announce the shift operations by voice instead of the indications.”</p> <p>E.g., col. 5, line 63 to col. 6, line 2, “Namely, in this step, the speed change operation indicating signal is applied to the indicator or display 10 from the microcomputer 5 through the I/O port 6. As a result, a particular lamp in this case, <i>a shift up indicating lamp in the indicator 10, is illuminated, thus indicating to the drive that the speed change from current shift position to the one step shifting up position SP<sub>+1</sub> is preferable.</i>”</p> <p>E.g. col. 7, lines 29 to 38, “However, <i>only when either one of the assumed fuel consumption rates above is better than the current fuel consumption rate B<sub>0</sub>, the corresponding shift-up lamp or shift-down lamp in the indicator 10 is illuminated</i>, thus indicating the necessity of the speed change operation.”</p>	
<p>said processor subsystem determining, based upon data received from said radar detector,</p>	<p>E.g., page 12.4, “During coasting and braking, fuel consumption can be further reduced by shutting off the fuel until the engine speed decreases to slightly higher than the set idle speed. <i>The ECU determines when fuel shutoff can occur by evaluating the throttle position,</i></p>	<p>E.g., col. 2, lines 37 to 42, “<i>The microcomputer 5 further comprises an input/output port (I/O port) 6, a central processing unit (CPU) 7, a read only memory (ROM) 8, and a random access memory (RAM) 9.</i> In the microcomputer 5, there is provided a bus BUS which</p>	<p>E.g., col. 8, lines 37 to 43, “<i>The microcomputer 4</i> as illustrated in FIGS. 6a, 6b is divided into various functional modules, as follows: a calculation module 90, <i>which receives data concerning the various parameters briefly described above</i> and as will be described more particularly below <i>to enable</i></p>

Limitation of '781 Patent Claim 17	Automotive Electronics Handbook (Jurgen)	U.S. Patent No. 4,559,599 (Toyota '599)	U.S. Patent No. 5,357,438 (Davidian)
<p>said at least one sensor and said memory subsystem, when to activate said vehicle proximity alarm circuit, when to activate said fuel overinjection circuit, and when to activate said upshift notification circuit.</p>	<p><i>engine RPM, and vehicle speed.</i></p> <p>E.g., page 12.14, "Using the inputs of engine RPM and vehicle speed to the electronic control unit, thresholds can be established for limiting these variables with fuel cutoff. <i>When the maximum speed is achieved, the fuel injectors are shut off.</i> When the speed decreases below the threshold, fuel injection resumes."</p> <p>E.g., page 13.7 to 13.9, "<i>The basic functions of the transmission control are the shift point control, the lockup control, engine torque control during shifting, related safety functions, and diagnostic functions for vehicle service.</i>"</p> <p>E.g., page 13.9, "The basic shift point control uses shift maps, which are defined in data in the unit memory. These shift maps are selectable over a wide range. <i>The shift point limitations are made, on the one hand, by the highest admissible engine speed for each application and, on the other hand, by the lowest engine speed that is practical for driving comfort and noise emission. The inputs of the shift point determination are the throttle position, the accelerator pedal position, and the vehicle speed (determined by the transmission output speed).</i>"</p>	<p>communicates the I/O port 6 and the CPU 7, ROM 8, and RAM 9."</p> <p>E.g., col. 2, lines 59 to 63, "<i>The input of the indicator 10 is connected to the output of the I/O port 6 so as to indicate each preferable shift position corresponding to the optimum fuel consumption rate in accordance with various parameters calculated.</i>"</p> <p>E.g., col. 5, line 63 to col. 6, line 2, "<i>Namely, in this step, the speed change operation indicating signal is applied to the indicator or display 10 from the microcomputer 5 through the I/O port 6. As a result, a particular lamp in this case, a shift up indicating lamp in the indicator 10, is illuminated, thus indicating to the driver that the speed change from current shift position to the one step shifting up position SP<sub>+1</sub> is preferable.</i>"</p>	<p><i>it to make the necessary computations for actuating the Safety alarm and the Collision alarm; ...</i></p> <p>E.g., col. 12, line 59 to col 13, line 11, "The system then makes the computations illustrated (as an example) in block 162 to determine the stopping distance SD, which is equal to the reaction distance plus the braking distance multiplied by a stopping factor ST and a safety factor SF. In the illustrated example, the stopping distance is the sum of the reaction distance and the braking distance. The reaction distance is the product of the reaction time, visibility condition, daylight condition, reaction factor and speed; and the braking distance is the product of the braking distance (as supplied by the manufacturer), road type, skidding danger, vehicle load and braking factor. <i>The stopping distance (SD) includes further safety factors, and determines when the safety alarm will be actuated to first alert the driver of an approaching collision danger.</i></p> <p><i>A determination is also made of the collision distance CD which is equal to the stopping distance SD divided by the collision safety factor CSF, e.g., 1.25 in the example illustrated above, such that should the distance between the vehicle and the object come within the collision distance CD, the collision alarm is then actuated.</i></p> <p>E.g., col. 13, lines 17 to 22, "<i>Whenever the distance between the vehicle and an object to the front of the vehicle or to the rear of the vehicle comes within the stopping distance SD and the collision distance CD, the system operates according to the deceleration alarm module 93, as</i></p>

Limitation of '781 Patent Claim 17	Automotive Electronics Handbook (Jurgen)	U.S. Patent No. 4,559,599 (Toyota '599)	U.S. Patent No. 5,357,438 (Davidian)
			indicated by block 164."

Limitation of '781 Patent Claim 18	Automotive Electronics Handbook (Jurgen)	U.S. Patent No. 4,559,599 (Toyota '599)	U.S. Patent No. 5,357,438 (Davidian)
18. Apparatus for optimizing operation of a vehicle according to claim 17 wherein:	See claim 17 claim chart, at page A-57.	See claim 17 claim chart, at page A-57.	See claim 17 claim chart, at page A-57.
said at least one sensor further includes a windshield wiper sensor for indicating whether a windshield wiper of said vehicle is activated; and			<p>E.g., col. 4, line 67 to col. 5, line 2, "The automatic sensors on vehicle 2 further include a daylight sensor 14, <i>a rain sensor 16</i>, a vehicle load sensor 18, a trailer-hitch sensor 20, and a reverse gear sensor 22."</p> <p>E.g., col. 8, lines 58 to 63, "Thus, module 90 receives inputs from the front space sensor 8, the rear space sensor 10, and the vehicle speed sensor 12. <i>Module 90 also receives inputs from the sensors in case there is no depressible key, e.g., the daylight sensor 14, the trailer sensor 20, the reverse gear sensor 22, the rain sensor 16, and the vehicle load sensor 18.</i>"</p>
said memory subsystem further storing a second vehicle speed/stopping distance table.			<p>E.g., col. 9, lines 20 to 27, "<i>Computer module 90 also includes information about the vehicle braking distances as a function of speed. This is preferably in the form of a look-up table</i>, for example, provided by the manufacturer for predetermined defined conditions concerning road type, skidding danger, vehicle load and tires pressure, and is <i>stored in a ROM (read-only memory) of the microcomputer so that it can be changed periodically if necessary.</i>"</p> <p>E.g., col. 12, line 59 to col 13, line 22, "The system then makes the computations illustrated (as an example) in block 162 to determine the stopping distance SD, which is equal to the reaction distance plus the braking distance multiplied by a stopping factor ST and a safety factor SF. <i>In the illustrated example, the stopping distance is the sum of the</i></p>

Limitation of '781 Patent Claim 18	Automotive Electronics Handbook (Jurgen)	U.S. Patent No. 4,559,599 (Toyota '599)	U.S. Patent No. 5,357,438 (Davidian)
			<p><i>reaction distance and the braking distance.</i> The reaction distance is the product of the reaction time, visibility condition, daylight condition, reaction factor and speed; and <i>the braking distance is the product of the braking distance (as supplied by the manufacturer),</i> road type, <i>skidding danger,</i> vehicle load and braking factor. The stopping distance (SD) includes further safety factors, and determines when the safety alarm will be actuated to first alert the driver of an approaching collision danger.</p> <p>A determination is also made of the collision distance CD which is equal to the stopping distance SD divided by the collision safety factor CSF, e.g., 1.25 in the example illustrated above, such that should the distance between the vehicle and the object come within the collision distance CD, the collision alarm is then actuated.</p> <p>The foregoing calculations of stopping distance SD and collision distance CD with respect to objects at the front of the vehicle are also made with respect to objects at the rear of the vehicle, these calculations being RSD and RCD, respectively, also shown in block 162.</p> <p>Whenever the distance between the vehicle and an object to the front of the vehicle or to the rear of the vehicle comes within the stopping distance SD and the collision distance CD, the system operates according to the deceleration alarm module 93, as indicated by block 164.”</p>

Limitation of '781 Patent Claim 19	Automotive Electronics Handbook (Jurgen)	U.S. Patent No. 4,559,599 (Toyota '599)	U.S. Patent No. 5,357,438 (Davidian)
19. Apparatus for optimizing operation of a vehicle according to claim 17 and further comprising:	See claim 17 claim chart, at page A-57.	See claim 17 claim chart, at page A-57.	See claim 17 claim chart, at page A-57.
a throttle controller for controlling a throttle of said engine of said vehicle; and	E.g., page 14.4, "When the error signal has been computed, <i>an output signal to the servo actuators is generated to increase, hold, or decrease the throttle position.</i> . . . Throttle positioning is traditionally either a vacuum type servo or motor."		E.g., col. 2, line 67 to col. 3, line 2, "According to a further feature, the system includes an actuator for actuating a mechanical system of the vehicle, e.g., <i>the brakes of a train</i> , or steering of an aircraft, at the time the collision alarm is actuated."
said processor subsystem selectively reducing said throttle based upon data received from said radar detector, said at least one sensor and said memory subsystem.			<p>E.g., col. 2, line 67 to col. 3, line 2, "According to a further feature, the system includes an actuator for actuating a mechanical system of the vehicle, e.g., <i>the brakes of a train</i>, or steering of an aircraft, at the time the collision alarm is actuated."</p> <p>E.g., col. 8, lines 37 to 43, "The <i>microcomputer 4</i> as illustrated in FIGS. 6a, 6b is divided into various functional modules, as follows: a calculation module 90, <i>which receives data concerning the various parameters briefly described above</i> and as will be described more particularly below <i>to enable it to make the necessary computations for actuating the Safety alarm and the Collision alarm; ...</i>"</p> <p>E.g., col. 12, line 59 to col 13, line 11, "The system then makes the computations illustrated (as an example) in block 162 to determine the stopping distance SD, which is equal to the reaction distance plus the braking distance multiplied by a stopping factor ST and a safety factor SF. In the illustrated example, the stopping distance is the sum of the reaction distance and the braking distance. The</p>



Limitation of '781 Patent Claim 19	Automotive Electronics Handbook (Jürgen)	U.S. Patent No. 4,559,599 (Toyota '599)	U.S. Patent No. 5,357,438 (Davidian)
			<p>reaction distance is the product of the reaction time, visibility condition, daylight condition, reaction factor and speed; and the braking distance is the product of the braking distance (as supplied by the manufacturer), road type, skidding danger, vehicle load and braking factor. <i>The stopping distance (SD) includes further safety factors, and determines when the safety alarm will be actuated to first alert the driver of an approaching collision danger.</i></p> <p><i>A determination is also made of the collision distance CD which is equal to the stopping distance SD divided by the collision safety factor CSF, e.g., 1.25 in the example illustrated above, such that should the distance between the vehicle and the object come within the collision distance CD, the collision alarm is then actuated."</i></p> <p>E.g., col. 13, lines 17 to 22, "<i>Whenever the distance between the vehicle and an object to the front of the vehicle or to the rear of the vehicle comes within the stopping distance SD and the collision distance CD, the system operates according to the deceleration alarm module 93, as indicated by block 164.</i>"</p>

Limitation of '781 Patent Claim 20	Automotive Electronics Handbook (Jurgen)	U.S. Patent No. 4,559,599 (Toyota '599)	U.S. Patent No. 5,357,438 (Davidian)
20. Apparatus for optimizing operation of a vehicle according to claim 19 wherein	See claim 19 claim chart, at page A-71.	See claim 19 claim chart, at page A-71.	See claim 19 claim chart, at page A-71.
said at least one sensor further includes a brake sensor for indicating whether a brake system of said vehicle is activated.	E.g., pages 7.21 to 22, "In antilock brake systems, speed sensors are attached to all wheels to determine wheel rotation speed and slip differential between wheels . . . <b><i>Brake pedal position and brake fluid pressure information are also required for control.</i></b> "		E.g., col. 6, lines 25 to 34, "Control panel 6 further includes a front distance display 46, in which are displayed the distance to the front vehicle (in region 46a), in which direction (by arrow 46b), and whether or not there is a collision danger (region 46c). A similar display, shown at 48 and having regions 48a, 48b and 48c, is provided with respect to the rear of the vehicle equipped with the system, whether a rear collision danger exists, and <b><i>the status of the rear brake light.</i></b> "  E.g., col. 8, lines 37 to 57, "The microcomputer 4 as illustrated in FIGS. 6a, 6b is divided into various functional modules, as follows: . . . a deceleration alarm module 93, which controls the Safety alarm and Collision alarm on the control panel, <b><i>the brake light actuator 26 and (e.g., in the case of a train) the vehicle brakes automatically;</i></b> a black box module 94, which controls the information recorded into and read out of the black box 28; and a driving ability test module 95, involved in the driving ability test 60 in the control panel of FIG. 2, or 80 in the control panel of FIG. 5. The operation of each of these modules (except the clock 91) is described more particularly below with reference to the flow charts of FIGS. 9-14."

Limitation of '781 Patent Claim 21	Automotive Electronics Handbook (Jurgen)	U.S. Patent No. 4,559,599 (Toyota '599)	U.S. Patent No. 5,357,438 (Davidian)
21. Apparatus for optimizing operation of a vehicle according to claim 19 wherein said processor subsystem further comprises:	See claim 19 claim chart, at page A-71.	See claim 19 claim chart, at page A-71.	See claim 19 claim chart, at page A-71.
means for counting a total number of vehicle proximity alarms determined by said processor subsystem;			<p>E.g., col. 11, lines 7 to 11, "ALSF Alarm stopping front counter; ALSR Alarm stopping rear counter; ALCF Alarm collision front counter; ALCR Alarm collision rear counter."</p> <p>E.g., col. 11, lines 60 to 68, "The ALSF and ALSR counters, the ALCF and ALCR counters, and the ALFA and ALRA accumulators in the above table, and referred to in the flow charts below, would be provided in the black box 28 which records all the incidents in which the safety alarm and collision alarm were actuated, including the time, vehicle speed and vehicle distance for each alarm incident."</p> <p>E.g., col. 14, lines 8 to 12, "Whenever the measured distance is equal to or less than the stopping distance (block 225), the system increments the alarm stopping front counter (block 228), records the time, distance and speed in the black box, and also actuates the safety alarm (block 229)."</p>
means for selectively reducing said throttle based upon said total number of vehicle proximity alarms.			<p>E.g., col. 2, line 67 to col. 3, line 2, "According to a further feature, the system includes an actuator for actuating a mechanical system of the vehicle, e.g., <i>the brakes of a train</i>, or steering of an aircraft, at the time the collision alarm is actuated."</p> <p>E.g., col. 8, lines 37 to 43, "The <i>microcomputer 4</i> as illustrated in FIGS. 6a, 6b is divided into various functional modules, as follows: a calculation module 90, <i>which receives data concerning the various parameters</i></p>

Limitation of '781 Patent Claim 21	Automotive Electronics Handbook (Jurgen)	U.S. Patent No. 4,559,599 (Toyota '599)	U.S. Patent No. 5,357,438 (Davidian)
			<p><i>briefly described above and as will be described more particularly below to enable it to make the necessary computations for actuating the Safety alarm and the Collision alarm; ...”</i></p> <p>E.g., col. 12, line 59 to col 13, line 11, “The system then makes the computations illustrated (as an example) in block 162 to determine the stopping distance SD, which is equal to the reaction distance plus the braking distance multiplied by a stopping factor ST and a safety factor SF. In the illustrated example, the stopping distance is the sum of the reaction distance and the braking distance. The reaction distance is the product of the reaction time, visibility condition, daylight condition, reaction factor and speed; and the braking distance is the product of the braking distance (as supplied by the manufacturer), road type, skidding danger, vehicle load and braking factor. <b>The stopping distance (SD) includes further safety factors, and determines when the safety alarm will be actuated to first alert the driver of an approaching collision danger.</b></p> <p><i>A determination is also made of the collision distance CD which is equal to the stopping distance SD divided by the collision safety factor CSF, e.g., 1.25 in the example illustrated above, such that should the distance between the vehicle and the object come within the collision distance CD, the collision alarm is then actuated.”</i></p> <p>E.g., col. 13, lines 17 to 22, “<b>Whenever the distance between the vehicle and an object to the front of the vehicle or to the rear of the vehicle comes within the stopping distance SD and the collision distance CD, the system operates according to the deceleration alarm module 93, as indicated by block 164.</b>”</p>

Limitation of '781 Patent Claim 22	Automotive Electronics Handbook (Jurgen)	U.S. Patent No. 4,559,599 (Toyota '599)	U.S. Patent No. 5,357,438 (Davidian)
22. Apparatus for optimizing operation of a vehicle according to claim 17 and further comprising:	See claim 17 claim chart, at page A-57.	See claim 17 claim chart, at page A-57.	See claim 17 claim chart, at page A-57.
a downshift notification circuit coupled to said processor subsystem, said downshift notification circuit issuing a notification that said engine of said vehicle is being operated at an insufficient engine speed; and	<p>E.g., page 13.7 to 13.9, "<i>The basic functions of the transmission control are the shift point control, the lockup control, engine torque control during shifting, related safety functions, and diagnostic functions for vehicle service.</i>"</p> <p>E.g., page 13.9, "The basic shift point control uses shift maps, which are defined in data in the unit memory. These shift maps are selectable over a wide range. <i>The shift point limitations are made, on the one hand, by the highest admissible engine speed for each application and, on the other hand, by the lowest engine speed that is practical for driving comfort and noise emission. The inputs of the shift point determination are the throttle position, the accelerator pedal position, and the vehicle speed (determined by the transmission output speed).</i>"</p> <p>E.g., page 13.14, "In addition to these functions, <i>different shift maps can be implemented into the data field of the TCU [Transmission Control Unit].</i> For example, it is possible to have one shift map for low fuel consumption, which has shift points in the range of the best efficiency of the engine, and additionally to have another map for power operation,</p>	<p>E.g., col. 2, line 64 to col. 3, line 3, "<i>The indicator 10 includes a shift-up indicating lamp 10a and a shift-down indicating lamp 10b.</i></p> <p><i>The indicator 10 may be assembled by light emitting [sic] diodes (LED) so as to perform shift-up and shift-down indications by up and down directed arrow marks.</i> Alternatively, the indicator 10 may also be replaced with other voice combining circuit so as to announce the shift operations by voice instead of the indications."</p> <p>E.g., col. 5, line 63 to col. 6, line 2, "Namely, in this step, the speed change operation indicating signal is applied to the indicator or display 10 from the microcomputer 5 through the I/O port 6. As a result, a particular lamp in this case, <i>a shift up indicating lamp in the indicator 10, is illuminated, thus indicating to the drive that the speed change from current shift position to the one step shifting up position SP<sub>+1</sub> is preferable.</i>"</p> <p>E.g. col. 7, lines 29 to 38, "However, <i>only when either one of the assumed fuel consumption rates above is better than the current fuel consumption rate B<sub>0</sub>, the corresponding shift-up lamp or shift-down lamp in the indicator 10 is illuminated, thus</i></p>	

Limitation of '781 Patent Claim 22	Automotive Electronics Handbook (Jurgen)	U.S. Patent No. 4,559,599 (Toyota '599)	U.S. Patent No. 5,357,438 (Davidian)
	where the shift points are placed at points of highest engine output power.”	indicating the necessity of the speed change operation.”	
said processor subsystem determining, based upon data received from said plurality of sensors, when to activate said downshift notification circuit.	<p>E.g., page 12.4, “During coasting and braking, fuel consumption can be further reduced by shutting off the fuel until the engine speed decreases to slightly higher than the set idle speed. <i>The ECU determines when fuel shutoff can occur by evaluating the throttle position, engine RPM, and vehicle speed.</i>”</p> <p>E.g., page 12.14, “Using the inputs of engine RPM and vehicle speed to the electronic control unit, thresholds can be established for limiting these variables with fuel cutoff. <i>When the maximum speed is achieved, the fuel injectors are shut off.</i> When the speed decreases below the threshold, fuel injection resumes.”</p> <p>E.g., page 13.7 to 13.9, “<i>The basic functions of the transmission control are the shift point control, the lockup control, engine torque control during shifting, related safety functions, and diagnostic functions for vehicle service.</i>”</p> <p>E.g., page 13.9, “The basic shift point control uses shift maps, which are defined in data in the unit memory. These shift maps are selectable over a wide range. <i>The shift point limitations are made, on the one hand, by the highest admissible engine speed for each application and, on the other hand, by the lowest engine speed that is practical for driving comfort and noise emission. The inputs of the shift</i></p>	<p>E.g., col. 2, lines 37 to 42, “<i>The microcomputer 5 further comprises an input/output port (I/O port) 6, a central processing unit (CPU) 7, a read only memory (ROM) 8, and a random access memory (RAM) 9.</i> In the microcomputer 5, there is provided a bus BUS which communicates the I/O port 6 and the CPU 7, ROM 8, and RAM 9.”</p> <p>E.g., col. 2, lines 59 to 63, “<i>The input of the indicator 10 is connected to the output of the I/O port 6 so as to indicate each preferable shift position corresponding to the optimum fuel consumption rate in accordance with various parameters calculated.</i>”</p> <p>E.g., col. 5, line 63 to col. 6, line 2, “<i>Namely, in this step, the speed change operation indicating signal is applied to the indicator or display 10 from the microcomputer 5 through the I/O port 6. As a result, a particular lamp in this case, a shift up indicating lamp in the indicator 10, is illuminated, thus indicating to the driver that the speed change from current shift position to the one step shifting up position SP<sub>+1</sub> is preferable.</i>”</p> <p>E.g., col. 2, line 64 to col. 3, line 3, “<i>The indicator 10 includes a shift-up indicating lamp 10a and a shift-down indicating lamp 10b.</i></p> <p><i>The indicator 10 may be assembled by light emitting [sic] diodes (LED) so as to perform</i></p>	<p>E.g., col. 8, lines 37 to 43, “<i>The microcomputer 4 as illustrated in FIGS. 6a, 6b is divided into various functional modules, as follows: a calculation module 90, which receives data concerning the various parameters briefly described above and as will be described more particularly below to enable it to make the necessary computations for actuating the Safety alarm and the Collision alarm; ...</i>”</p> <p>E.g., col. 12, line 59 to col 13, line 11, “<i>The system then makes the computations illustrated (as an example) in block 162 to determine the stopping distance SD, which is equal to the reaction distance plus the braking distance multiplied by a stopping factor ST and a safety factor SF. In the illustrated example, the stopping distance is the sum of the reaction distance and the braking distance. The reaction distance is the product of the reaction time, visibility condition, daylight condition, reaction factor and speed; and the braking distance is the product of the braking distance (as supplied by the manufacturer), road type, skidding danger, vehicle load and braking factor. The stopping distance (SD) includes further safety factors, and determines when the safety alarm will be actuated to first alert the driver of an approaching collision danger.</i></p> <p><i>A determination is also made of the collision distance CD which is equal to the stopping distance SD divided by the collision safety factor CSF, e.g., 1.25 in the example illustrated above, such that should the distance between the vehicle and the object come within the collision distance CD, the collision alarm is then actuated.</i>”</p>

Limitation of '781 Patent Claim 22	Automotive Electronics Handbook (Jürgen)	U.S. Patent No. 4,559,599 (Toyota '599)	U.S. Patent No. 5,357,438 (Davidian)
	<p><i>point determination are the throttle position, the accelerator pedal position, and the vehicle speed (determined by the transmission output speed)."</i></p>	<p><i>shift-up and shift-down indications by up and down directed arrow marks. Alternatively, the indicator 10 may also be replaced with other voice combining circuit so as to announce the shift operations by voice instead of the indications."</i></p> <p>E.g., col. 7, lines 10 to 17, "<i>In this step 42, shift-down display is performed. Namely in this case, the shift down display instruction signal from the microcomputer 5 is applied to the indicator 10 through the I/O port 6 and the shift-down indication lamp in the indicator 10 is illuminated, thus indicating to the driver that speed change operation from the current shift position to the one step shifting down position SP<sub>1</sub> is preferable."</i></p> <p>E.g. col. 7, lines 29 to 38, "<i>However, only when either one of the assumed fuel consumption rates above is better than the current fuel consumption rate B<sub>0</sub>, the corresponding shift-up lamp or shift-down lamp in the indicator 10 is illuminated, thus indicating the necessity of the speed change operation."</i></p>	<p>E.g., col. 13, lines 17 to 22, "<i>Whenever the distance between the vehicle and an object to the front of the vehicle or to the rear of the vehicle comes within the stopping distance SD and the collision distance CD, the system operates according to the deceleration alarm module 93, as indicated by block 164."</i></p>

Limitation of '781 Patent Claim 23	Automotive Electronics Handbook (Jurgen)	U.S. Patent No. 4,559,599 (Toyota '599)	U.S. Patent No. 5,357,438 (Davidian)
<p>23. Apparatus for optimizing operation of a vehicle, comprising:</p>	<p>E.g., page 12.1, "The electronic engine control system consists of sensing devices which continuously measure the operating conditions of the engine, <i>an electronic control unit (ECU) which evaluates the sensor inputs using data tables and calculations and determines the output to the actuating devices</i>, and actuating devices which are commanded by the ECU to perform an action in response to the sensor inputs.</p> <p>The motive for using an electronic engine control system is to provide the needed accuracy and adaptability in order to minimize exhaust emissions and fuel consumption, <i>provide optimal driveability for all operating conditions</i>, minimize evaporative emissions, and provide system diagnosis when malfunctions occur."</p>	<p>E.g., Abstract, "<i>A shift indication apparatus</i> having an engine rotation sensor, a throttle valve sensor, and a shift position sensor, a microcomputer having a ROM and RAM for storing data corresponding to the engine speed, throttle valve openings, and the shift positions therein, and an indicator for indicating preferable shift positions to be performed by a driver in which a torque data map and a fuel consumption rate data map have stored in the ROM for calculating various torque and fuel consumption rates <i>so as to obtain preferable shift positions relating to optimum fuel consumption rate in accordance with said data detected. With this construction, it becomes possible for a driver to run his car in accordance with the indications of the shift operation on the indicator so as to enable the economical running of the car to be realized.</i>"</p>	<p>E.g., col. 1, lines 1 to 2, "The present invention relates to <i>an anti-collision system for vehicles.</i>"</p>
<p>a radar detector, said radar detector determining a distance separating a vehicle having an engine and an object in front of said vehicle;</p>	<p>E.g., page 7.23, "Ultrasonics, infrared, laser, and <i>microwaves (radar) can be used in the detection of objects behind vehicles and in the blind areas.</i>"</p>		<p>E.g., col. 4, lines 52 to 66, "<i>Vehicle 2 further includes a front space sensor 8 for sensing the space in front of the vehicle, such as the presence of another vehicle, a corresponding rear space sensor 10, and a pair of side sensors 11.</i> All the space sensors are in the form of pulse (e.g., ultrasonic) transmitters and receivers, for determining the distance of the vehicle from an object, e.g., another vehicle, at front or rear. Space sensors may also be provided at the sides of the vehicle. Vehicle 2 is further equipped with a speed sensor 12 which may sense the speed of the vehicle in any known manner, for example using the speed measuring system of the vehicle itself, or a speed measuring system independent of the vehicle, e.g., an acceleration sensor, or by calculations based on</p>



Limitation of '781 Patent Claim 23	Automotive Electronics Handbook (Jurgen)	U.S. Patent No. 4,559,599 (Toyota '599)	U.S. Patent No. 5,357,438 (Davidian)
			<p>the Doppler effect, etc.”</p> <p>E.g., col. 10, lines 17 to 26, “FIG. 7 is a circuit diagram of the microcomputer 4 and the other components of the electrical system. The microprocessor is indicated by block 100, its power supply by block 102, and its watchdog circuit by block 104. <i>It includes a transmitter 106 and a receiver 108 for transmitting and receiving the pulses (e.g., RF, ultrasound, laser, IR, etc.) in the front space sensor 8 and the rear space sensor 10 for measuring the distance of the vehicle from objects in front of, and to the rear, of the vehicle, respectively.</i>”</p> <p>E.g., col. 10, lines 38 to 50, “As indicated earlier, the distance of the vehicle from an object is determined by the front space sensor 8 with respect to objects in front of the vehicle, and by the rear space sensor 10 with respect to objects at the rear of the vehicle. Each of these space sensors may be of known construction, including a transmitter as indicated at 106 in FIG. 7, and a receiver as indicated at 108. <i>Thus, pulses are continuously transmitted by each transmitter, and the echoes from the objects in front of or to the rear of the vehicle are received by the respective receiver. The computer then measures the round-trip time from the pulse transmission to the echo reception in order to determine the distance of the vehicle from the object.</i>”</p>
a plurality of sensors coupled to a vehicle having an engine, said	E.g., page 7.6, “There are several applications for rotational speed sensing. <i>First it is necessary to monitor engine speed.</i> This information is used for transmission control, engine control, cruise control, and possibly for a tachometer.	E.g., col. 2, lines 23 to 36, “Referring to FIG. 1, the shift indication apparatus with a manual transmission according to the present invention comprises <i>an engine speed sensor 1 for detecting the engine speed and for producing</i>	E.g., col. 4, lines 60 to 66, “Vehicle 2 is further equipped with <i>a speed sensor 12 which may sense the speed of the vehicle in any known manner,</i> for example using the speed measuring system of the vehicle itself, or a speed measuring system

Limitation of '781 Patent Claim 23	Automotive Electronics Handbook (Jurgen)	U.S. Patent No. 4,559,599 (Toyota '599)	U.S. Patent No. 5,357,438 (Davidian)
<p>plurality of sensors, which collectively monitor operation of said vehicle, including a road speed sensor, and engine speed sensor, a manifold pressure sensor and a throttle position sensor;</p>	<p>Electronics and electronic sensing in the automobile were brought about by the need for higher efficiency engines, better fuel economy, increased power and performance, and lower emissions. Second, <i>wheel speed sensing is required</i> for use in transmissions, cruise control, speedometers, antilock brake systems (ABS), traction control (ASR), variable ratio power steering assist, four-wheel steering, and possibly in inertial navigation and air bag deployment applications.”</p> <p>E.g., page 7.8, “In electronic transmission applications, <i>information from the road and engine speed sensors</i>, as well as torque data and throttle position are required for the MCU to select the optimum gear ratio.”</p> <p>E.g., page 2.5, “Automotive specification and testing guidelines have been developed and published by the Society of Automotive Engineers (SAE) specifically for <i>manifold absolute pressure (MAP) sensors</i>.”</p> <p>E.g., page 2.7, “Manifold absolute pressure (MAP) is used as an input to fuel and ignition control in internal combustion engine control systems. <i>The speed-density system that uses the MAP sensor</i> has been preferred over mass air flow (MAF) control because it's less expensive, but stricter emission standards are causing more manufacturers to use mass air flow for future models.”</p> <p>E.g., page 12.18, “To control the idle speed, the ECU uses inputs from the <i>throttle position</i></p>	<p><i>pulse signals of a frequency proportional to the engine speed</i>, a shift position sensor 2 for detecting the shift positions of the transmission, <i>a throttle sensor 3 for detecting the opening degree of the throttle valve by means of, for instance, a potentiometer</i>, an A/D converter 4 for converting analog signals from the throttle valve sensor 3 into digital signals, a microcomputer 5 for performing various calculations in accordance with the different signals from the sensors, and an indicator 10 for indicating the result of the calculations.”</p> <p>E.g., col. 2, lines 43 to 48, “<i>The engine speed sensor 1</i> is mounted in a distributor (not shown) and the output of the sensor is connected to the input of the I/O port 6 so as to transmit the output pulses to the microcomputer 5 through the I/O port 6 and to store the data corresponding to the engine speed into the RAM 9.”</p> <p>E.g., col. 2, lines 52 to 59, “Similarly, the output of <i>the throttle sensor 3</i> is connected through the A/D converter 4 to the input of the I/O port 6 so as to transmit the output signals thereof to the microcomputer 5 through the A/D converter 4 and to store the data corresponding to the throttle value opening into the RAM 9 after converting from the analog signals into the digital signals.”</p> <p>E.g., FIG. 1:</p>	<p>independent of the vehicle, e.g., an acceleration sensor, or by calculations based on the Doppler effect, etc.”</p>

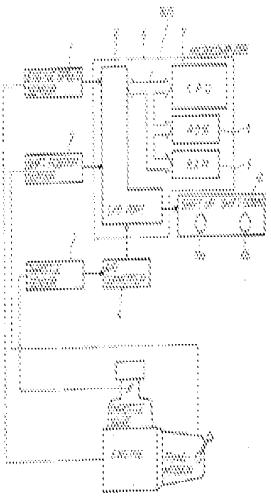
Limitation of '781 Patent Claim 23	Automotive Electronics Handbook (Jurgen)	U.S. Patent No. 4,559,599 (Toyota '599)	U.S. Patent No. 5,357,438 (Davidian)
	<p><i>sensor</i>, air conditioning, automatic transmission, power steering, charging system, engine RPM, and vehicle speed.”</p> <p>E.g., page 12.21, “The electronic injection unit also houses the <i>throttle position sensor</i> and, in some cases, an inlet air temperature sensor which provides operating condition information to the ECU.”</p>		
<p>a processor subsystem, coupled to said radar detector and each one of said plurality of sensors, to receive data therefrom;</p>	<p>E.g., page 12.1, “The electronic engine control system consists of <i>sensing devices which continuously measure the operating conditions of the engine, an electronic control unit (ECU) which evaluates the sensor inputs</i> using data tables and calculations and determines the output to the actuating devices, and actuating devices which are commanded by the ECU to perform an action in response to the sensor inputs.”</p> <p>E.g., page 22.6, “During the entire operating time of the vehicle, <i>the ECUs are constantly supervising the sensors they are connected to.</i>”</p> <p>E.g., page 13.4, “On the functional side, the hardware configuration can be divided into power supply, input signal transfer circuits, output stages, and <i>microcontroller</i>, including peripheral components and monitoring and safety circuits (Fig. 13.1).”</p> <p>E.g., Figure 13.1:</p>	<p>E.g., col. 2, lines 23 to 36, “Referring to FIG. 1, the shift indication apparatus with a manual transmission according to the present invention comprises an engine speed sensor 1 for detecting the engine speed and for producing pulse signals of a frequency proportional to the engine speed, a shift position sensor 2 for detecting the shift positions of the transmission, a throttle sensor 3 for detecting the opening degree of the throttle valve by means of, for instance, a potentiometer, an A/D converter 4 for converting analog signals from the throttle valve sensor 3 into digital signals, <i>a microcomputer 5 for performing various calculations in accordance with the different signals from the sensors</i>, and an indicator 10 for indicating the result of the calculations.”</p> <p>E.g., col. 2, lines 37 to 42, “<i>The microcomputer 5</i> further comprises an input/output port (I/O port) 6, <i>a central processing unit (CPU) 7</i>, a read only memory (ROM) 8, and a random access</p>	<p>E.g., col. 8, lines 29 to 43, “<i>FIGS. 6a, 6b, are a block diagram illustrating the microcomputer 4 and its inputs and outputs described earlier which enable it to continuously monitor the operation of the vehicle</i> and to actuate first a Safety alarm, and then a Collision alarm whenever the vehicle may enter a danger-of-collision situation according to the various preset parameters and automatic parameters introduced into the computer.</p> <p><i>The microcomputer 4 as illustrated in FIGS. 6a, 6b is divided into various functional modules, as follows: a calculation module 90, which receives data concerning the various parameters briefly described above and as will be described more particularly below to enable it to make the necessary computations for actuating the Safety alarm and the Collision alarm.</i>”</p> <p>E.g., col. 8, lines 58 to 60, “Thus, module 90 receives inputs from the front space sensor 8, the rear space sensor 10, and the vehicle speed sensor</p>

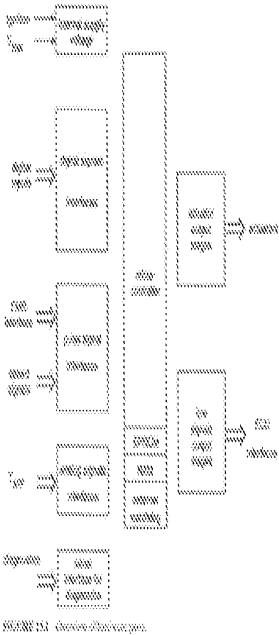
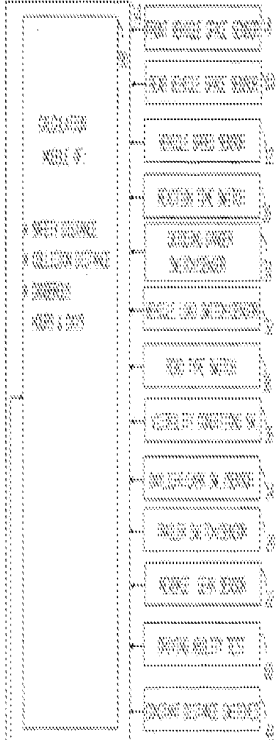
Limitation of '781 Patent Claim 23	Automotive Electronics Handbook (Jurgen)	U.S. Patent No. 4,559,599 (Toyota '599)	U.S. Patent No. 5,357,438 (Davidian)
	 <p>E.g., page 14.3, "The speed sensor is one of the most critical parts in the system, because the <i>microcontroller calculates the vehicle speed from the speed sensor's signal</i> to within 1/32 m/h."</p>	<p>memory (RAM) 9. In the microcomputer 5, there is provided a bus BUS which communicates the I/O port 6 and the CPU 7, ROM 8, and RAM 9."</p> <p>E.g., col. 2, lines 43 to 48, "The engine speed sensor 1 is mounted in a distributor (not shown) and <i>the output of the sensor is connected to the input of the I/O port 6 so as to transmit the output pulses to the microcomputer 5</i> through the I/O port 6 and to store the data corresponding to the engine speed into the RAM 9."</p> <p>E.g., col. 2, lines 52 to 59, "Similarly, <i>the output of the throttle sensor 3 is connected through the A/D converter 4 to the input of the I/O port 6 so as to transmit the output signals thereof to the microcomputer 5</i> through the A/D converter 4 and to store the data corresponding to the throttle value opening into the RAM 9 after converting from the analog signals into the digital signals."</p>	<p>12."</p> <p>E.g., Figure 6A:</p>  <p>FIG. 6A</p>
<p>a memory subsystem, coupled to said processor subsystem, said memory subsystem storing therein a first vehicle speed/stopping</p>	<p>E.g., page 13.5, "The calculators inside the control units are usually microcontrollers. . . . <i>The memory devices for program and data are usually EPROMS.</i> Their storage capacity is, in present applications, up to 64 Kbytes. Future applications will necessitate storage sizes up to 128 Kbytes. The failure storages for diagnostics and the storage for adaptive data are in conventional applications, battery voltage-supplied RAMs. These are increasingly being</p>	<p>E.g., col. 2, lines 37 to 42, "The microcomputer 5 further comprises an input/output port (I/O port) 6, a central processing unit (CPU) 7, <i>a read only memory (ROM) 8, and a random access memory (RAM) 9.</i> In the microcomputer 5, there is provided a bus BUS which communicates the I/O port 6 and the CPU 7, ROM 8, and RAM 9."</p> <p>E.g., col. 3, lines 7 to 20, "<i>The torque data map indicative of torque curves T as shown in FIG. 2</i></p>	<p>E.g., col. 9, lines 20 to 27, "<i>Computer module 90 also includes information about the vehicle braking distances as a function of speed. This is preferably in the form of a look-up table, for example, provided by the manufacturer for predetermined defined conditions concerning road type, skidding danger, vehicle load and tires pressure, and is stored in a ROM (read-only memory) of the microcomputer so that it can be changed periodically if necessary.</i>"</p>

Limitation of '781 Patent Claim 23	Automotive Electronics Handbook (Jurgen)	U.S. Patent No. 4,559,599 (Toyota '599)	U.S. Patent No. 5,357,438 (Davidian)
<p>distance table, a manifold pressure set point, an RPM set point, and present and prior levels for each one of said plurality of sensors;</p>	<p>replaced by EEPROMs.”</p> <p>E.g., page 12.9, “A subsystem of the fuel control system is lambda closed-loop control. . . .</p> <p>[T]he engine control unit uses an anticipatory control strategy that uses engine load and RPM to determine the approximate fuel requirement. <i>The engine load information is provided by the manifold pressure sensor for speed density systems and by the air meter for air flow and air mass measurement systems and by the throttle valve position sensor. The engine control unit contains data tables for combinations of load and RPM.</i> This allows for rapid response to changes in operating conditions. The lambda sensor still provides the feedback correction for each load/RPM point. . . .</p> <p>[T]he electronic control unit has a feature for adapting changes in the fuel required for the load/RPM points. <i>At each load/RPM point, the lambda sensor continuously provides information that allows the system to adjust the fuel to the commanded A/F ratio. The corrected information is stored in RAM (random access memory) so that the next time the engine reaches that operating point (load/RPM), the anticipatory value will require less correction. These values remain stored in the electronic control unit even after the engine is shut off.</i> Only if power to the electronic control unit is disrupted (i.e., due to a dead battery), will the correction be lost. In that case, the electronic control unit will revert back to the original production values that are written in ROM (read-only memory).”</p>	<p><i>has been stored in the ROM 8 in advance. The fuel consumption rate data map indicative of equal fuel consumption rate curves B as shown in FIG. 3 has been also stored in the ROM 8 in advance. In FIG. 2, each equal torque curve T was prepared by plotting and connecting equal torque points on the graph with respect to the engine speed vs. throttle valve opening.</i> In FIG. 3, each fuel consumption rate curve B was prepared by plotting and connecting equal fuel consumption rate points on a graph obtained in advance by experiment data with respect to the engine speed and the torques thus calculated.”</p> <p>E.g., col. 3, lines 44 to 61, “<i>In this case, as shown in FIG. 4, the operation of a main routine is started at a predetermined timing, e.g. periodical timing pulses from a timer (not shown) and the detection of the engine speed <math>N_e</math> from the sensor 1 is carried out and it is stored into the RAM 9 at the step 20. Then, the engine speed <math>N_e</math> is read from the RAM 9 and it is compared with a predetermined number <math>N</math> (=1000 rpm) to determine whether or not the <math>N_e</math> exceeds the value 1000 at the step 21.</i> If the result of the decision is YES, the next step 22 is executed. That is, in the step 22, the reading in of the opening of the throttle valve is performed through the throttle sensor 3 and the A/D converter 4. In the above case, if the result of the decision in step 21 is NO, the main routine is terminated by determining that the shift operation is not necessary and the engine speed <math>N_e</math> is read again at the predetermined timing and now the operation returns to the step 20.”</p> <p>E.g., Figure 4:</p>	<p>E.g., col. 12, line 59 to col 13, line 22, “The system then makes the computations illustrated (as an example) in block 162 to determine the stopping distance SD, which is equal to the reaction distance plus the braking distance multiplied by a stopping factor ST and a safety factor SF. <i>In the illustrated example, the stopping distance is the sum of the reaction distance and the braking distance. The reaction distance is the product of the reaction time, visibility condition, daylight condition, reaction factor and speed; and the braking distance is the product of the braking distance (as supplied by the manufacturer), road type, skidding danger, vehicle load and braking factor.</i> The stopping distance (SD) includes further safety factors, and determines when the safety alarm will be actuated to first alert the driver of an approaching collision danger.</p> <p><i>A determination is also made of the collision distance CD which is equal to the stopping distance SD divided by the collision safety factor CSF, e.g., 1.25 in the example illustrated above, such that should the distance between the vehicle and the object come within the collision distance CD, the collision alarm is then actuated.</i></p> <p>The foregoing calculations of stopping distance SD and collision distance CD with respect to objects at the front of the vehicle are also made with respect to objects at the rear of the vehicle, these calculations being RSD and RCD, respectively, also shown in block 162.</p> <p>Whenever the distance between the vehicle and an object to the front of the vehicle or to the rear of the</p>

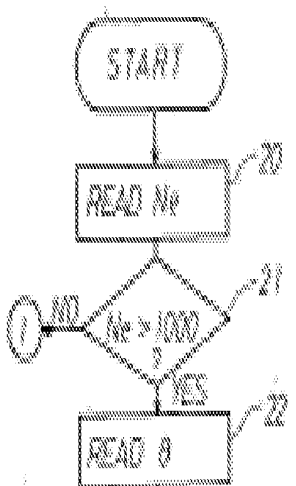
Limitation of '781 Patent Claim 23	Automotive Electronics Handbook (Jurgen)	U.S. Patent No. 4,559,599 (Toyota '599)	U.S. Patent No. 5,357,438 (Davidian)
	<p>E.g., page 14.2, "Other safety-related items include <i>program code to detect abnormal operating conditions and preserving into memory the data points associated with the abnormal condition for later diagnostics.</i> Abnormal conditions, for example, could be an intermittent vehicle speed sensor, or erratic driver switch signals."</p> <p>E.g., pages 22.2 to 22.3, "The most important test points of control units and sensors are tied to a diagnostic connector which is plugged into the measuring instrument with a corresponding adapter for the respective vehicle. . . . <i>Modern electronics in vehicles support diagnosis by comparing the registered actual value with the internally stored nominal values</i> with the help of control units and their self-diagnosis, thus detecting faults."</p>	 <pre> graph TD     START([START]) --&gt; READ_Np[READ Np]     READ_Np --&gt; DEC{Np &gt; 1000?}     DEC -- NO --&gt; END(( ))     DEC -- YES --&gt; READ_0[READ 0]   </pre>	<p>vehicle comes within the stopping distance SD and the collision distance CD, the system operates according to the deceleration alarm module 93, as indicated by block 164."</p>
<p>a fuel overinjection notification circuit coupled to said processor subsystem, said fuel overinjection notification circuit issuing a notification that excessive fuel is being supplied to said engine of said vehicle;</p>	<p>E.g., page 12.22, "During an acceleration transition, the ECU adds a correction factor (an increase) to the commanded injector pulse width. The sudden increase in air results in a lean mixture which must be corrected swiftly to obtain good transitional response. <i>During a deceleration transition, the fuel can be shut off by simply not providing a pulse width signal to the injector to minimize exhaust emissions and fuel consumption.</i>"</p> <p>E.g., page 12.4, "During coasting and braking, fuel consumption can be further reduced by shutting off the fuel until the engine speed decreases to slightly higher than the set idle speed. <i>The ECU determines when fuel shutoff</i></p>		

Limitation of '781 Patent Claim 23	Automotive Electronics Handbook (Jurgen)	U.S. Patent No. 4,559,599 (Toyota '599)	U.S. Patent No. 5,357,438 (Davidian)
	<p><i>can occur by evaluating the throttle position, engine RPM, and vehicle speed.”</i></p> <p>E.g., page 12.14, “Using the inputs of engine RPM and vehicle speed to the electronic control unit, thresholds can be established for limiting these variables with fuel cutoff. <i>When the maximum speed is achieved, the fuel injectors are shut off.</i> When the speed decreases below the threshold, fuel injection resumes.”</p> <p>E.g., page 12.17, “<i>During transition to fuel cutoff, the ignition timing is retarded from its current setting to reduce engine torque and to assist in engine braking. The fuel is then shut off.</i> During the transition, the throttle bypass valve or the main throttle valve may remain open for a short period to allow fresh air to oxidize the remaining unburned HC and CO to further reduce exhaust emissions. During development of the fuel cutoff strategy, the advantage of reduced emission effects and catalyst temperature control must be balanced against driveability requirements. The use of fuel cutoff may change the perceived amount of engine braking felt by the driver. In addition, care must be taken to avoid a ‘bump’ feel when entering the fuel cutoff mode, due to the change in torque.”</p>		
<p>an upshift notification circuit coupled to said processor subsystem, said upshift notification circuit issuing a</p>	<p>E.g., page 13.7 to 13.9, “<i>The basic functions of the transmission control are the shift point control, the lockup control, engine torque control during shifting, related safety functions, and diagnostic functions for vehicle service.</i>”</p> <p>E.g., page 13.9, “The basic shift point control uses shift maps, which are defined in data in the</p>	<p>E.g., col. 2, line 64 to col. 3, line 3, “<i>The indicator 10 includes a shift-up indicating lamp 10a and a shift-down indicating lamp 10b.</i></p> <p><i>The indicator 10 may be assembled by light emitting [sic] diodes (LED) so as to perform shift-up and shift-down indications by up and down directed arrow marks.</i> Alternatively, the</p>	

Limitation of '781 Patent Claim 23	Automotive Electronics Handbook (Jurgen)	U.S. Patent No. 4,559,599 (Toyota '599)	U.S. Patent No. 5,357,438 (Davidian)
notification that said engine of said vehicle is being operated at an excessive engine speed;	<p>unit memory. These shift maps are selectable over a wide range. <i>The shift point limitations are made, on the one hand, by the highest admissible engine speed for each application</i> and, on the other hand, by the lowest engine speed that is practical for driving comfort and noise emission. <i>The inputs of the shift point determination are the throttle position, the accelerator pedal position, and the vehicle speed</i> (determined by the transmission output speed)."</p> <p>E.g., page 13.14, "In addition to these functions, <i>different shift maps can be implemented into the data field of the TCU [Transmission Control Unit]</i>. For example, it is possible to have one shift map for low fuel consumption, which has shift points in the range of the best efficiency of the engine, and additionally to have another map for power operation, where the shift points are placed at points of highest engine output power."</p>	<p>indicator 10 may also be replaced with other voice combining circuit so as to announce the shift operations by voice instead of the indications."</p> <p>E.g., col. 5, line 63 to col. 6, line 2, "Namely, in this step, the speed change operation indicating signal is applied to the indicator or display 10 from the microcomputer 5 through the I/O port 6. As a result, a particular lamp in this case, <i>a shift up indicating lamp in the indicator 10, is illuminated, thus indicating to the drive that the speed change from current shift position to the one step shifting up position SP<sub>+1</sub> is preferable.</i>"</p> <p>E.g. col. 7, lines 29 to 38, "However, <i>only when either one of the assumed fuel consumption rates above is better than the current fuel consumption rate B<sub>n</sub>, the corresponding shift-up lamp or shift-down lamp in the indicator 10 is illuminated</i>, thus indicating the necessity of the speed change operation."</p>	
said processor subsystem determining, based upon data received from said plurality of sensors, when to activate said fuel overinjection circuit and when to activate said upshift notification	<p>E.g., page 12.4, "During coasting and braking, fuel consumption can be further reduced by shutting off the fuel until the engine speed decreases to slightly higher than the set idle speed. <i>The ECU determines when fuel shutoff can occur by evaluating the throttle position, engine RPM, and vehicle speed.</i>"</p> <p>E.g., page 12.14, "Using the inputs of engine RPM and vehicle speed to the electronic control unit, thresholds can be established for limiting these variables with fuel cutoff. <i>When the maximum speed is achieved, the fuel injectors</i></p>	<p>E.g., col. 2, lines 37 to 42, "<i>The microcomputer 5 further comprises an input/output port (I/O port) 6, a central processing unit (CPU) 7, a read only memory (ROM) 8, and a random access memory (RAM) 9.</i> In the microcomputer 5, there is provided a bus BUS which communicates the I/O port 6 and the CPU 7, ROM 8, and RAM 9."</p> <p>E.g., col. 2, lines 59 to 63, "<i>The input of the indicator 10 is connected to the output of the I/O port 6 so as to indicate each preferable shift position corresponding to the optimum fuel</i></p>	



Limitation of '781 Patent Claim 23	Automotive Electronics Handbook (Jurgen)	U.S. Patent No. 4,559,599 (Toyota '599)	U.S. Patent No. 5,357,438 (Davidian)
circuit;	<p><i>are shut off.</i> When the speed decreases below the threshold, fuel injection resumes.”</p> <p>E.g., page 13.7 to 13.9, “<i>The basic functions of the transmission control are the shift point control, the lockup control, engine torque control during shifting, related safety functions, and diagnostic functions for vehicle service.</i>”</p> <p>E.g., page 13.9, “The basic shift point control uses shift maps, which are defined in data in the unit memory. These shift maps are selectable over a wide range. <i>The shift point limitations are made, on the one hand, by the highest admissible engine speed for each application and, on the other hand, by the lowest engine speed that is practical for driving comfort and noise emission. The inputs of the shift point determination are the throttle position, the accelerator pedal position, and the vehicle speed (determined by the transmission output speed).</i>”</p>	<p><i>consumption rate in accordance with various parameters calculated.</i>”</p> <p>E.g., col. 5, line 63 to col. 6, line 2, “<i>Namely, in this step, the speed change operation indicating signal is applied to the indicator or display 10 from the microcomputer 5 through the I/O port 6. As a result, a particular lamp in this case, a shift up indicating lamp in the indicator 10, is illuminated, thus indicating to the driver that the speed change from current shift position to the one step shifting up position SP<sub>+1</sub> is preferable.</i>”</p>	
a vehicle proximity alarm circuit coupled to said processor subsystem, said vehicle proximity alarm circuit issuing an alarm that said vehicle is too close to said object;			<p>E.g., col. 3, lines 59 to 66, “The anti-collision system illustrated in FIGS. 1-14 is particularly useful for motor vehicles (passengers cars, buses, trucks) in order to <i>actuate an alarm when the vehicle is travelling at a distance behind another vehicle or in front of another</i>, which is equal to or less than a danger-of-collision distance computed by a computer such that if the front vehicle stops suddenly there is a danger of a rear-end collision.”</p> <p>E.g., col. 4, lines 14 to 16, “In the system described below, <i>there are two alarms: a Collision alarm, which is actuated when the vehicle is determined to be within the danger-of-collision distance; and</i></p>

Limitation of '781 Patent Claim 23	Automotive Electronics Handbook (Jurgen)	U.S. Patent No. 4,559,599 (Toyota '599)	U.S. Patent No. 5,357,438 (Davidian)
			<p><i>a Safety alarm, which is actuated before the Collision alarm, at a distance greater than the danger-of-collision distance by a predetermined safety factor, e.g., 1.25."</i></p> <p>E.g., col. 6, lines 25 to 29, "Control panel 6 further includes a front distance display 46, in which are displayed the distance to the front vehicle (in region 46a), in which direction (by arrow 46b), and <i>whether or not there is a collision danger (region 46c).</i>"</p> <p>E.g., col. 6, lines 41 to 46, "Control panel 6 further includes a speaker 54 for producing an <i>audio alarm in the event of a collision danger, in addition to the visually-indicated alarms</i> of sections 46c and 48c of the displays 46 and 48."</p> <p>E.g., col. 8, lines 37 to 48, "The <i>microcomputer 4</i> as illustrated in FIGS. 6a, 6b is divided into various functional modules, as follows:  <i>... a deceleration alarm module 93, which controls the Safety alarm and Collision alarm on the control panel, ..."</i></p> <p>E.g., Figs. 3 and 6B (ref. no. 46C)</p>
said processor subsystem determining, based upon data received from said radar detector, said at least one sensor and said memory subsystem, when			<p>E.g., col. 8, lines 37 to 43, "The <i>microcomputer 4</i> as illustrated in FIGS. 6a, 6b is divided into various functional modules, as follows: a calculation module 90, <i>which receives data concerning the various parameters briefly described above</i> and as will be described more particularly below <i>to enable it to make the necessary computations for actuating the Safety alarm and the Collision alarm; ..."</i></p>

Limitation of '781 Patent Claim 23	Automotive Electronics Handbook (Jurgen)	U.S. Patent No. 4,559,599 (Toyota '599)	U.S. Patent No. 5,357,438 (Davidian)
to activate said vehicle proximity alarm circuit.			<p>E.g., col. 12, line 59 to col 13, line 11, "The system then makes the computations illustrated (as an example) in block 162 to determine the stopping distance SD, which is equal to the reaction distance plus the braking distance multiplied by a stopping factor ST and a safety factor SF. In the illustrated example, the stopping distance is the sum of the reaction distance and the braking distance. The reaction distance is the product of the reaction time, visibility condition, daylight condition, reaction factor and speed; and the braking distance is the product of the braking distance (as supplied by the manufacturer), road type, skidding danger, vehicle load and braking factor. <i>The stopping distance (SD) includes further safety factors, and determines when the safety alarm will be actuated to first alert the driver of an approaching collision danger.</i></p> <p><i>A determination is also made of the collision distance CD which is equal to the stopping distance SD divided by the collision safety factor CSF, e.g., 1.25 in the example illustrated above, such that should the distance between the vehicle and the object come within the collision distance CD, the collision alarm is then actuated."</i></p> <p>E.g., col. 13, lines 17 to 22, "<i>Whenever the distance between the vehicle and an object to the front of the vehicle or to the rear of the vehicle comes within the stopping distance SD and the collision distance CD, the system operates according to the deceleration alarm module 93, as indicated by block 164.</i>"</p>

Limitation of '781 Patent Claim 26	Automotive Electronics Handbook (Jurgen)	U.S. Patent No. 4,559,599 (Toyota '599)	U.S. Patent No. 5,357,438 (Davidian)
<p>26. Apparatus for optimizing operation of a vehicle, comprising:</p>	<p>E.g., page 12.1, "The electronic engine control system consists of sensing devices which continuously measure the operating conditions of the engine, <i>an electronic control unit (ECU) which evaluates the sensor inputs using data tables and calculations and determines the output to the actuating devices</i>, and actuating devices which are commanded by the ECU to perform an action in response to the sensor inputs.</p> <p>The motive for using an electronic engine control system is to provide the needed accuracy and adaptability in order to minimize exhaust emissions and fuel consumption, <i>provide optimal driveability for all operating conditions</i>, minimize evaporative emissions, and provide system diagnosis when malfunctions occur."</p>	<p>E.g., Abstract, "<i>A shift indication apparatus</i> having an engine rotation sensor, a throttle valve sensor, and a shift position sensor, a microcomputer having a ROM and RAM for storing data corresponding to the engine speed, throttle valve openings, and the shift positions therein, and an indicator for indicating preferable shift positions to be performed by a driver in which a torque data map and a fuel consumption rate data map have stored in the ROM for calculating various torque and fuel consumption rates <i>so as to obtain preferable shift positions relating to optimum fuel consumption rate in accordance with said data detected</i>. <i>With this construction, it becomes possible for a driver to run his car in accordance with the indications of the shift operation on the indicator so as to enable the economical running of the car to be realized.</i>"</p>	<p>E.g., col. 1, lines 1 to 2, "The present invention relates to <i>an anti-collision system for vehicles.</i>"</p>
<p>a radar detector, said radar detector determining a distance separating a vehicle having an engine and an object in front of said vehicle;</p>	<p>E.g., page 7.23, "Ultrasonics, infrared, laser, and <i>microwaves (radar) can be used in the detection of objects behind vehicles and in the blind areas.</i>"</p>		<p>E.g., col. 4, lines 52 to 66, "<i>Vehicle 2 further includes a front space sensor 8 for sensing the space in front of the vehicle, such as the presence of another vehicle, a corresponding rear space sensor 10, and a pair of side sensors 11.</i> All the space sensors are in the form of pulse (e.g., ultrasonic) transmitters and receivers, for determining the distance of the vehicle from an object, e.g., another vehicle, at front or rear. Space sensors may also be provided at the sides of the vehicle. Vehicle 2 is further equipped with a speed sensor 12 which may sense the speed of the vehicle in any known manner, for example using the speed measuring system of the vehicle itself, or a speed measuring system independent of the vehicle, e.g., an acceleration sensor, or by calculations based on the Doppler effect, etc."</p>

Limitation of '781 Patent Claim 26	Automotive Electronics Handbook (Jurgen)	U.S. Patent No. 4,559,599 (Toyota '599)	U.S. Patent No. 5,357,438 (Davidian)
			<p>E.g., col. 10, lines 17 to 26, "FIG. 7 is a circuit diagram of the microcomputer 4 and the other components of the electrical system. The microprocessor is indicated by block 100, its power supply by block 102, and its watchdog circuit by block 104. <i>It includes a transmitter 106 and a receiver 108 for transmitting and receiving the pulses (e.g., RF, ultrasound, laser, IR, etc.) in the front space sensor 8 and the rear space sensor 10 for measuring the distance of the vehicle from objects in front of, and to the rear, of the vehicle, respectively.</i>"</p> <p>E.g., col. 10, lines 38 to 50, "As indicated earlier, the distance of the vehicle from an object is determined by the front space sensor 8 with respect to objects in front of the vehicle, and by the rear space sensor 10 with respect to objects at the rear of the vehicle. Each of these space sensors may be of known construction, including a transmitter as indicated at 106 in FIG. 7, and a receiver as indicated at 108. <i>Thus, pulses are continuously transmitted by each transmitter, and the echoes from the objects in front of or to the rear of the vehicle are received by the respective receiver. The computer then measures the round-trip time from the pulse transmission to the echo reception in order to determine the distance of the vehicle from the object.</i>"</p>
a plurality of sensors coupled to a vehicle having an engine, said plurality of	E.g., page 7.6, "There are several applications for rotational speed sensing. <i>First it is necessary to monitor engine speed.</i> This information is used for transmission control, engine control, cruise control, and possibly for a tachometer. Electronics and electronic sensing in the automobile were	E.g., col. 2, lines 23 to 36, "Referring to FIG. 1, the shift indication apparatus with a manual transmission according to the present invention comprises <i>an engine speed sensor 1 for detecting the engine speed and for producing pulse signals of a frequency proportional to the</i>	E.g., col. 4, lines 60 to 66, "Vehicle 2 is further equipped with <i>a speed sensor 12 which may sense the speed of the vehicle in any known manner,</i> for example using the speed measuring system of the vehicle itself, or a speed measuring system independent of the vehicle, e.g., an acceleration

Limitation of '781 Patent Claim 26	Automotive Electronics Handbook (Jurgen)	U.S. Patent No. 4,559,599 (Toyota '599)	U.S. Patent No. 5,357,438 (Davidian)
<p>sensors, which collectively monitor operation of said vehicle, including a road speed sensor, and engine speed sensor, a manifold pressure sensor and a throttle position sensor;</p>	<p>brought about by the need for higher efficiency engines, better fuel economy, increased power and performance, and lower emissions. Second, <i>wheel speed sensing is required</i> for use in transmissions, cruise control, speedometers, antilock brake systems (ABS), traction control (ASR), variable ratio power steering assist, four-wheel steering, and possibly in inertial navigation and air bag deployment applications.”</p> <p>E.g., page 7.8, “In electronic transmission applications, <i>information from the road and engine speed sensors</i>, as well as torque data and throttle position are required for the MCU to select the optimum gear ratio.”</p> <p>E.g., page 2.5, “Automotive specification and testing guidelines have been developed and published by the Society of Automotive Engineers (SAE) specifically for <i>manifold absolute pressure (MAP) sensors</i>.”</p> <p>E.g., page 2.7, “Manifold absolute pressure (MAP) is used as an input to fuel and ignition control in internal combustion engine control systems. <i>The speed-density system that uses the MAP sensor</i> has been preferred over mass air flow (MAF) control because it's less expensive, but stricter emission standards are causing more manufacturers to use mass air flow for future models.”</p> <p>E.g., page 12.18, “To control the idle speed, the ECU uses inputs from the <i>throttle position sensor</i>, air conditioning, automatic transmission, power steering, charging system, engine RPM, and</p>	<p><i>engine speed</i>, a shift position sensor 2 for detecting the shift positions of the transmission, <i>a throttle sensor 3 for detecting the opening degree of the throttle valve by means of, for instance, a potentiometer</i>, an A/D converter 4 for converting analog signals from the throttle valve sensor 3 into digital signals, a microcomputer 5 for performing various calculations in accordance with the different signals from the sensors, and an indicator 10 for indicating the result of the calculations.”</p> <p>E.g., col. 2, lines 43 to 48, “<i>The engine speed sensor 1</i> is mounted in a distributor (not shown) and the output of the sensor is connected to the input of the I/O port 6 so as to transmit the output pulses to the microcomputer 5 through the I/O port 6 and to store the data corresponding to the engine speed into the RAM 9.”</p> <p>E.g., col. 2, lines 52 to 59, “Similarly, the output of <i>the throttle sensor 3</i> is connected through the A/D converter 4 to the input of the I/O port 6 so as to transmit the output signals thereof to the microcomputer 5 through the A/D converter 4 and to store the data corresponding to the throttle value opening into the RAM 9 after converting from the analog signals into the digital signals.”</p> <p>E.g., FIG. 1:</p>	<p>sensor, or by calculations based on the Doppler effect, etc.”</p>

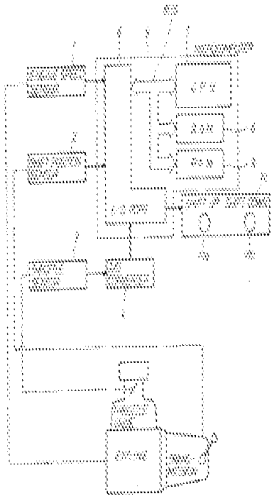
Limitation of '781 Patent Claim 26	Automotive Electronics Handbook (Jurgen)	U.S. Patent No. 4,559,599 (Toyota '599)	U.S. Patent No. 5,357,438 (Davidian)
	<p>vehicle speed.”</p> <p>E.g., page 12.21, “The electronic injection unit also houses the <i>throttle position sensor</i> and, in some cases, an inlet air temperature sensor which provides operating condition information to the ECU.”</p>		
<p>a processor subsystem, coupled to said radar detector and each one of said plurality of sensors, to receive data therefrom;</p>	<p>E.g., page 12.1, “The electronic engine control system consists of <i>sensing devices which continuously measure the operating conditions of the engine, an electronic control unit (ECU) which evaluates the sensor inputs</i> using data tables and calculations and determines the output to the actuating devices, and actuating devices which are commanded by the ECU to perform an action in response to the sensor inputs.”</p> <p>E.g., page 22.6, “During the entire operating time of the vehicle, <i>the ECUs are constantly supervising the sensors they are connected to.</i>”</p> <p>E.g., page 13.4, “On the functional side, the hardware configuration can be divided into power supply, input signal transfer circuits, output stages, and <i>microcontroller</i>, including peripheral components and monitoring and safety circuits (Fig. 13.1).”</p> <p>E.g., Figure 13.1:</p>	<p>E.g., col. 2, lines 23 to 36, “Referring to FIG. 1, the shift indication apparatus with a manual transmission according to the present invention comprises an engine speed sensor 1 for detecting the engine speed and for producing pulse signals of a frequency proportional to the engine speed, a shift position sensor 2 for detecting the shift positions of the transmission, a throttle sensor 3 for detecting the opening degree of the throttle valve by means of, for instance, a potentiometer, an A/D converter 4 for converting analog signals from the throttle valve sensor 3 into digital signals, <i>a microcomputer 5 for performing various calculations in accordance with the different signals from the sensors</i>, and an indicator 10 for indicating the result of the calculations.”</p> <p>E.g., col. 2, lines 37 to 42, “<i>The microcomputer 5</i> further comprises an input/output port (I/O port) 6, <i>a central processing unit (CPU) 7</i>, a read only memory (ROM) 8, and a random access</p>	<p>E.g., col. 8, lines 29 to 43, “<i>FIGS. 6a, 6b, are a block diagram illustrating the microcomputer 4 and its inputs and outputs described earlier which enable it to continuously monitor the operation of the vehicle</i> and to actuate first a Safety alarm, and then a Collision alarm whenever the vehicle may enter a danger-of-collision situation according to the various preset parameters and automatic parameters introduced into the computer.</p> <p><i>The microcomputer 4 as illustrated in FIGS. 6a, 6b is divided into various functional modules, as follows: a calculation module 90, which receives data concerning the various parameters briefly described above and as will be described more particularly below to enable it to make the necessary computations for actuating the Safety alarm and the Collision alarm.</i>”</p> <p>E.g., col. 8, lines 58 to 60, “Thus, module 90 receives inputs from the front space sensor 8, the rear space sensor 10, and the vehicle speed sensor</p>

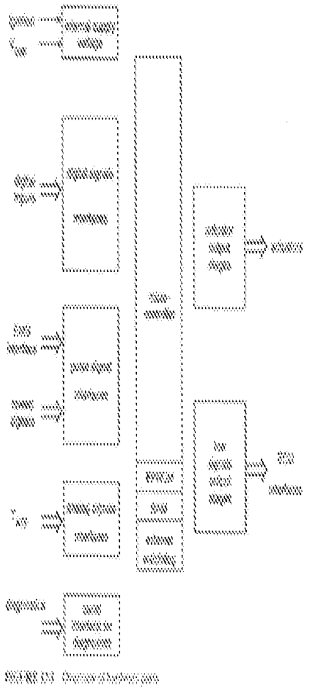
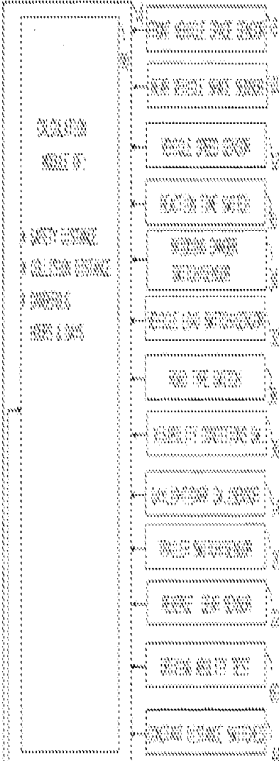
Limitation of '781 Patent Claim 26	Automotive Electronics Handbook (Jurgen)	U.S. Patent No. 4,559,599 (Toyota '599)	U.S. Patent No. 5,357,438 (Davidian)
	 <p>E.g., page 14.3, "The speed sensor is one of the most critical parts in the system, because the <i>microcontroller calculates the vehicle speed from the speed sensor's signal</i> to within 1/32 m/h."</p>	<p>memory (RAM) 9. In the microcomputer 5, there is provided a bus BUS which communicates the I/O port 6 and the CPU 7, ROM 8, and RAM 9."</p> <p>E.g., col. 2, lines 43 to 48, "The engine speed sensor 1 is mounted in a distributor (not shown) and <i>the output of the sensor is connected to the input of the I/O port 6 so as to transmit the output pulses to the microcomputer 5</i> through the I/O port 6 and to store the data corresponding to the engine speed into the RAM 9."</p> <p>E.g., col. 2, lines 52 to 59, "Similarly, <i>the output of the throttle sensor 3 is connected through the A/D converter 4 to the input of the I/O port 6 so as to transmit the output signals thereof to the microcomputer 5</i> through the A/D converter 4 and to store the data corresponding to the throttle value opening into the RAM 9 after converting from the analog signals into the digital signals."</p>	<p>12."</p> <p>E.g., Figure 6A:</p>  <p>FIG. 6A</p>
<p>a memory subsystem, coupled to said processor subsystem, said memory subsystem storing therein a first vehicle</p>	<p>E.g., page 13.5, "The calculators inside the control units are usually microcontrollers. . . . <i>The memory devices for program and data are usually EPROMS.</i> Their storage capacity is, in present applications, up to 64 Kbytes. Future applications will necessitate storage sizes up to 128 Kbytes. The failure storages for diagnostics and the storage for adaptive data are in conventional applications, battery voltage-</p>	<p>E.g., col. 2, lines 37 to 42, "The microcomputer 5 further comprises an input/output port (I/O port) 6, a central processing unit (CPU) 7, <i>a read only memory (ROM) 8, and a random access memory (RAM) 9.</i> In the microcomputer 5, there is provided a bus BUS which communicates the I/O port 6 and the CPU 7, <i>ROM 8, and RAM 9.</i>"</p> <p>E.g., col. 3, lines 7 to 20, "<i>The torque data map</i></p>	<p>E.g., col. 9, lines 20 to 27, "<i>Computer module 90 also includes information about the vehicle braking distances as a function of speed. This is preferably in the form of a look-up table,</i> for example, provided by the manufacturer for predetermined defined conditions concerning road type, skidding danger, vehicle load and tires pressure, and is <i>stored in a ROM (read-only memory) of the microcomputer so that it can be</i></p>

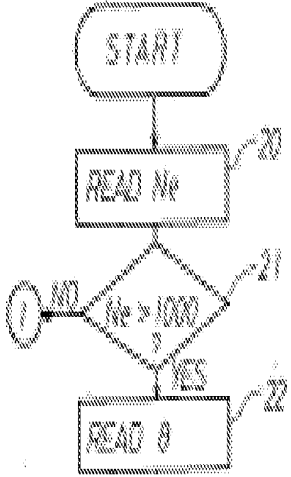

Limitation of '781 Patent Claim 26	Automotive Electronics Handbook (Jurgen)	U.S. Patent No. 4,559,599 (Toyota '599)	U.S. Patent No. 5,357,438 (Davidian)
<p>speed/stopping distance table, a manifold pressure set point, RPM set point, and present and prior levels for each one of said plurality of sensors;</p>	<p>supplied RAMs. These are increasingly being replaced by EEPROMs.”</p> <p>E.g., page 12.9, “A subsystem of the fuel control system is lambda closed-loop control. . . .</p> <p>[T]he engine control unit uses an anticipatory control strategy that uses engine load and RPM to determine the approximate fuel requirement. <i>The engine load information is provided by the manifold pressure sensor for speed density systems and by the air meter for air flow and air mass measurement systems and by the throttle valve position sensor. The engine control unit contains data tables for combinations of load and RPM.</i> This allows for rapid response to changes in operating conditions. The lambda sensor still provides the feedback correction for each load/RPM point. . . .</p> <p>[T]he electronic control unit has a feature for adapting changes in the fuel required for the load/RPM points. <i>At each load/RPM point, the lambda sensor continuously provides information that allows the system to adjust the fuel to the commanded A/F ratio. The corrected information is stored in RAM (random access memory) so that the next time the engine reaches that operating point (load/RPM), the anticipatory value will require less correction. These values remain stored in the electronic control unit even after the engine is shut off.</i> Only if power to the electronic control unit is disrupted (i.e., due to a dead battery), will the correction be lost. In that case, the electronic control unit will revert back to the original production values that are written in ROM (read-only memory).”</p>	<p><i>indicative of torque curves T as shown in FIG. 2 has been stored in the ROM 8 in advance. The fuel consumption rate data map indicative of equal fuel consumption rate curves B as shown in FIG. 3 has been also stored in the ROM 8 in advance. In FIG. 2, each equal torque curve T was prepared by plotting and connecting equal torque points on the graph with respect to the engine speed vs. throttle valve opening.</i> In FIG. 3, each fuel consumption rate curve B was prepared by plotting and connecting equal fuel consumption rate points on a graph obtained in advance by experiment data with respect to the engine speed and the torques thus calculated.”</p> <p>E.g., col. 3, lines 44 to 61, “<i>In this case, as shown in FIG. 4, the operation of a main routine is started at a predetermined timing, e.g. periodical timing pulses from a timer (not shown) and the detection of the engine speed <math>N_e</math> from the sensor 1 is carried out and it is stored into the RAM 9 at the step 20. Then, the engine speed <math>N_e</math> is read from the RAM 9 and it is compared with a predetermined number <math>N</math> (=1000 rpm) to determine whether or not the <math>N_e</math> exceeds the value 1000 at the step 21.</i> If the result of the decision is YES, the next step 22 is executed. That is, in the step 22, the reading in of the opening of the throttle valve is performed through the throttle sensor 3 and the A/D converter 4. In the above case, if the result of the decision in step 21 is NO, the main routine is terminated by determining that the shift operation is not necessary and the engine speed <math>N_e</math> is read again at the predetermined timing and now the operation returns to the step 20.”</p>	<p><i>changed periodically if necessary.”</i></p> <p>E.g., col. 12, line 59 to col 13, line 22, “The system then makes the computations illustrated (as an example) in block 162 to determine the stopping distance SD, which is equal to the reaction distance plus the braking distance multiplied by a stopping factor ST and a safety factor SF. <i>In the illustrated example, the stopping distance is the sum of the reaction distance and the braking distance. The reaction distance is the product of the reaction time, visibility condition, daylight condition, reaction factor and speed; and the braking distance is the product of the braking distance (as supplied by the manufacturer), road type, skidding danger, vehicle load and braking factor.</i> The stopping distance (SD) includes further safety factors, and determines when the safety alarm will be actuated to first alert the driver of an approaching collision danger.</p> <p><i>A determination is also made of the collision distance CD which is equal to the stopping distance SD divided by the collision safety factor CSF, e.g., 1.25 in the example illustrated above, such that should the distance between the vehicle and the object come within the collision distance CD, the collision alarm is then actuated.</i></p> <p>The foregoing calculations of stopping distance SD and collision distance CD with respect to objects at the front of the vehicle are also made with respect to objects at the rear of the vehicle, these calculations being RSD and RCD, respectively, also shown in block 162.</p> <p>Whenever the distance between the vehicle and an</p>

Limitation of '781 Patent Claim 26	Automotive Electronics Handbook (Jurgen)	U.S. Patent No. 4,559,599 (Toyota '599)	U.S. Patent No. 5,357,438 (Davidian)
	<p>E.g., page 14.2, "Other safety-related items include <i>program code to detect abnormal operating conditions and preserving into memory the data points associated with the abnormal condition for later diagnostics</i>. Abnormal conditions, for example, could be an intermittent vehicle speed sensor, or erratic driver switch signals."</p> <p>E.g., pages 22.2 to 22.3, "The most important test points of control units and sensors are tied to a diagnostic connector which is plugged into the measuring instrument with a corresponding adapter for the respective vehicle. . . . <i>Modern electronics in vehicles support diagnosis by comparing the registered actual value with the internally stored nominal values</i> with the help of control units and their self-diagnosis, thus detecting faults."</p>	<p>E.g., Figure 4:</p>  <pre> graph TD     Start([START]) --&gt; ReadNe[READ Ne 20]     ReadNe --&gt; Decision{Ne &gt; 1000 21}     Decision -- NO --&gt; ReadNe     Decision -- YES --&gt; Read0[READ 0 22] </pre>	<p>object to the front of the vehicle or to the rear of the vehicle comes within the stopping distance SD and the collision distance CD, the system operates according to the deceleration alarm module 93, as indicated by block 164."</p>
<p>a fuel overinjection notification circuit coupled to said processor subsystem, said fuel overinjection notification circuit issuing a notification that excessive fuel is being supplied to said engine of said vehicle;</p>	<p>E.g., page 12.22, "During an acceleration transition, the ECU adds a correction factor (an increase) to the commanded injector pulse width. The sudden increase in air results in a lean mixture which must be corrected swiftly to obtain good transitional response. <i>During a deceleration transition, the fuel can be shut off by simply not providing a pulse width signal to the injector to minimize exhaust emissions and fuel consumption.</i>"</p> <p>E.g., page 12.4, "During coasting and braking, fuel consumption can be further reduced by shutting off the fuel until the engine speed decreases to slightly higher than the set idle speed. <i>The ECU determines when fuel shutoff can</i></p>		

Limitation of '781 Patent Claim 26	Automotive Electronics Handbook (Jurgen)	U.S. Patent No. 4,559,599 (Toyota '599)	U.S. Patent No. 5,357,438 (Davidian)
	<p><i>occur by evaluating the throttle position, engine RPM, and vehicle speed.”</i></p> <p>E.g., page 12.14, “Using the inputs of engine RPM and vehicle speed to the electronic control unit, thresholds can be established for limiting these variables with fuel cutoff. <i>When the maximum speed is achieved, the fuel injectors are shut off.</i> When the speed decreases below the threshold, fuel injection resumes.”</p> <p>E.g., page 12.17, “<i>During transition to fuel cutoff, the ignition timing is retarded from its current setting to reduce engine torque and to assist in engine braking. The fuel is then shut off.</i> During the transition, the throttle bypass valve or the main throttle valve may remain open for a short period to allow fresh air to oxidize the remaining unburned HC and CO to further reduce exhaust emissions. During development of the fuel cutoff strategy, the advantage of reduced emission effects and catalyst temperature control must be balanced against driveability requirements. The use of fuel cutoff may change the perceived amount of engine braking felt by the driver. In addition, care must be taken to avoid a ‘bump’ feel when entering the fuel cutoff mode, due to the change in torque.”</p>		
<p>a downshift notification circuit coupled to said processor subsystem, said downshift notification</p>	<p>E.g., page 13.7 to 13.9, “<i>The basic functions of the transmission control are the shift point control, the lockup control, engine torque control during shifting, related safety functions, and diagnostic functions for vehicle service.</i>”</p> <p>E.g., page 13.9, “The basic shift point control uses shift maps, which are defined in data in the unit</p>	<p>E.g., col. 2, line 64 to col. 3, line 3, “<i>The indicator 10 includes a shift-up indicating lamp 10a and a shift-down indicating lamp 10b.</i></p> <p><i>The indicator 10 may be assembled by light emitting [sic] diodes (LED) so as to perform shift-up and shift-down indications by up and down directed arrow marks.</i> Alternatively, the</p>	

Limitation of '781 Patent Claim 26	Automotive Electronics Handbook (Jurgen)	U.S. Patent No. 4,559,599 (Toyota '599)	U.S. Patent No. 5,357,438 (Davidian)
<p>circuit issuing a notification that said engine of said vehicle is being operated at an insufficient engine speed;</p>	<p>memory. These shift maps are selectable over a wide range. <i>The shift point limitations are made</i>, on the one hand, by the highest admissible engine speed for each application and, on the other hand, <i>by the lowest engine speed that is practical for driving comfort and noise emission. The inputs of the shift point determination are the throttle position, the accelerator pedal position, and the vehicle speed</i> (determined by the transmission output speed).”</p> <p>E.g., page 13.14, “In addition to these functions, <i>different shift maps can be implemented into the data field of the TCU [Transmission Control Unit].</i> For example, it is possible to have one shift map for low fuel consumption, which has shift points in the range of the best efficiency of the engine, and additionally to have another map for power operation, where the shift points are placed at points of highest engine output power.”</p>	<p>indicator 10 may also be replaced with other voice combining circuit so as to announce the shift operations by voice instead of the indications.”</p> <p>E.g., col. 7, lines 10 to 17, “<i>In this step 42, shift-down display is performed. Namely in this case, the shift down display instruction signal from the microcomputer 5 is applied to the indicator 10 through the I/O port 6 and the shift-down indication lamp in the indicator 10 is illuminated</i>, thus indicating to the driver that speed change operation from the current shift position to the one step shifting down position SP<sub>1</sub> is preferable.”</p> <p>E.g. col. 7, lines 29 to 38, “However, <i>only when either one of the assumed fuel consumption rates above is better than the current fuel consumption rate B<sub>n</sub>, the corresponding shift-up lamp or shift-down lamp in the indicator 10 is illuminated</i>, thus indicating the necessity of the speed change operation.”</p>	
<p>said processor subsystem determining, based upon data received from said plurality of sensors, when to activate said fuel overinjection circuit and when to activate said downshift</p>	<p>E.g., page 12.4, “During coasting and braking, fuel consumption can be further reduced by shutting off the fuel until the engine speed decreases to slightly higher than the set idle speed. <i>The ECU determines when fuel shutoff can occur by evaluating the throttle position, engine RPM, and vehicle speed.</i>”</p> <p>E.g., page 12.14, “Using the inputs of engine RPM and vehicle speed to the electronic control unit, thresholds can be established for limiting these variables with fuel cutoff. <i>When the maximum speed is achieved, the fuel injectors</i></p>	<p>E.g., col. 2, lines 37 to 42, “<i>The microcomputer 5 further comprises an input/output port (I/O port) 6, a central processing unit (CPU) 7, a read only memory (ROM) 8, and a random access memory (RAM) 9.</i> In the microcomputer 5, there is provided a bus BUS which communicates the I/O port 6 and the CPU 7, ROM 8, and RAM 9.”</p> <p>E.g., col. 2, lines 59 to 63, “<i>The input of the indicator 10 is connected to the output of the I/O port 6 so as to indicate each preferable shift position corresponding to the optimum fuel</i></p>	

Limitation of '781 Patent Claim 26	Automotive Electronics Handbook (Jurgen)	U.S. Patent No. 4,559,599 (Toyota '599)	U.S. Patent No. 5,357,438 (Davidian)
notification circuit;	<p><i>are shut off.</i> When the speed decreases below the threshold, fuel injection resumes.”</p> <p>E.g., pages 13.7 to 13.9, “<i>The basic functions of the transmission control are the shift point control, the lockup control, engine torque control during shifting, related safety functions, and diagnostic functions for vehicle service.</i>”</p> <p>E.g., page 13.9, “The basic shift point control uses shift maps, which are defined in data in the unit memory. These shift maps are selectable over a wide range. <i>The shift point limitations are made, on the one hand, by the highest admissible engine speed for each application and, on the other hand, by the lowest engine speed that is practical for driving comfort and noise emission. The inputs of the shift point determination are the throttle position, the accelerator pedal position, and the vehicle speed (determined by the transmission output speed).</i>”</p>	<p><i>consumption rate in accordance with various parameters calculated.</i>”</p> <p>E.g., col. 5, line 63 to col. 6, line 2, “<i>Namely, in this step, the speed change operation indicating signal is applied to the indicator or display 10 from the microcomputer 5 through the I/O port 6. As a result, a particular lamp in this case, a shift up indicating lamp in the indicator 10, is illuminated, thus indicating to the drive that the speed change from current shift position to the one step shifting up position SP<sub>+i</sub> is preferable.</i>”</p> <p>E.g., col. 2, line 64 to col. 3, line 3, “<i>The indicator 10 includes a shift-up indicating lamp 10a and a shift-down indicating lamp 10b.</i></p> <p><i>The indicator 10 may be assembled by light emitting [sic] diodes (LED) so as to perform shift-up and shift-down indications by up and down directed arrow marks.</i> Alternatively, the indicator 10 may also be replaced with other voice combining circuit so as to announce the shift operations by voice instead of the indications.”</p> <p>E.g., col. 7, lines 10 to 17, “<i>In this step 42, shift-down display is performed. Namely in this case, the shift down display instruction signal from the microcomputer 5 is applied to the indicator 10 through the I/O port 6 and the shift-down indication lamp in the indicator 10 is illuminated, thus indicating to the driver that speed change operation from the current shift position to the one step shifting down position SP<sub>-1</sub> is preferable.</i>”</p>	

Limitation of '781 Patent Claim 26	Automotive Electronics Handbook (Jurgen)	U.S. Patent No. 4,559,599 (Toyota '599)	U.S. Patent No. 5,357,438 (Davidian)
		E.g. col. 7, lines 29 to 38, "However, <i>only when either one of the assumed fuel consumption rates above is better than the current fuel consumption rate B<sub>0</sub>, the corresponding shift-up lamp or shift-down lamp in the indicator 10 is illuminated</i> , thus indicating the necessity of the speed change operation."	
a vehicle proximity alarm circuit coupled to said processor subsystem, said vehicle proximity alarm circuit issuing an alarm that said vehicle is too close to said object;	<p>E.g., page 7.6, "[W]heel speed sensing is required for use in transmissions, cruise control, speedometers, antilock brake systems (ABS), traction control (ASR), variable ratio power steering assist, four-wheel steering, and possibly in inertial navigation and air bag deployment applications.</p> <p>Linear speed sensing can be used to measure the ground speed. This measurement also has the possibly of use in ABS, ASR, and inertial navigation. <i>Similar types of sensors can be used in crash avoidance, proximity, and obstacle detection applications.</i>"</p> <p>E.g., page 7.23, "Ultrasonics, infrared, laser, and microwaves (radar) can be used in the detection of objects behind vehicles and in the blind areas."</p>		<p>E.g., col. 3, lines 59 to 66, "The anti-collision system illustrated in FIGS. 1-14 is particularly useful for motor vehicles (passengers cars, buses, trucks) in order to <i>actuate an alarm when the vehicle is travelling at a distance behind another vehicle or in front of another</i>, which is equal to or less than a danger-of-collision distance computed by a computer such that if the front vehicle stops suddenly there is a danger of a rear-end collision."</p> <p>E.g., col. 4, lines 14 to 16, "In the system described below, <i>there are two alarms: a Collision alarm, which is actuated when the vehicle is determined to be within the danger-of-collision distance; and a Safety alarm, which is actuated before the Collision alarm, at a distance greater than the danger-of-collision distance by a predetermined safety factor</i>, e.g., 1.25."</p> <p>E.g., col. 6, lines 25 to 29, "Control panel 6 further includes a front distance display 46, in which are displayed the distance to the front vehicle (in region 46a), in which direction (by arrow 46b), and <i>whether or not there is a collision danger (region 46c).</i>"</p> <p>E.g., col. 6, lines 41 to 46, "Control panel 6 further includes a speaker 54 for producing an <i>audio alarm in the event of a collision danger, in addition to the</i></p>

Limitation of '781 Patent Claim 26	Automotive Electronics Handbook (Jurgen)	U.S. Patent No. 4,559,599 (Toyota '599)	U.S. Patent No. 5,357,438 (Davidian)
			<p><i>visually-indicated alarms</i> of sections 46c and 48c of the displays 46 and 48.”</p> <p>E.g., col. 8, lines 37 to 48, “The <i>microcomputer 4</i> as illustrated in FIGS. 6a, 6b is divided into various functional modules, as follows:  <i>... a deceleration alarm module 93, which controls the Safety alarm and Collision alarm on the control panel, ...</i>”</p> <p>E.g., Figs. 3 and 6B (ref. no. 46C)</p>
<p>said processor subsystem determining, based upon data received from said radar detector, said at least one sensor and said memory subsystem, when to activate said vehicle proximity alarm circuit.</p>			<p>E.g., col. 8, lines 37 to 43, “The <i>microcomputer 4</i> as illustrated in FIGS. 6a, 6b is divided into various functional modules, as follows: a calculation module 90, which receives data concerning the various parameters briefly described above and as will be described more particularly below to enable it to make the necessary computations for actuating the Safety alarm and the Collision alarm; ...”</p> <p>E.g., col. 12, line 59 to col 13, line 11, “The system then makes the computations illustrated (as an example) in block 162 to determine the stopping distance SD, which is equal to the reaction distance plus the braking distance multiplied by a stopping factor ST and a safety factor SF. In the illustrated example, the stopping distance is the sum of the reaction distance and the braking distance. The reaction distance is the product of the reaction time, visibility condition, daylight condition, reaction factor and speed; and the braking distance is the product of the braking distance (as supplied by the manufacturer), road type, skidding danger, vehicle load and braking factor. <i>The stopping distance (SD) includes further safety factors, and determines when the safety alarm will be actuated to first alert</i></p>

Limitation of '781 Patent Claim 26	Automotive Electronics Handbook (Jurgen)	U.S. Patent No. 4,559,599 (Toyota '599)	U.S. Patent No. 5,357,438 (Davidian)
			<p><i>the driver of an approaching collision danger.</i></p> <p><i>A determination is also made of the collision distance CD which is equal to the stopping distance SD divided by the collision safety factor CSF, e.g., 1.25 in the example illustrated above, such that should the distance between the vehicle and the object come within the collision distance CD, the collision alarm is then actuated."</i></p> <p>E.g., col. 13, lines 17 to 22, "<i>Whenever the distance between the vehicle and an object to the front of the vehicle or to the rear of the vehicle comes within the stopping distance SD and the collision distance CD, the system operates according to the deceleration alarm module 93, as indicated by block 164.</i>"</p>



5. Claims 17–23 and 26 are Obvious in View of the Combination of Jurgen, Volkswagen '070, and Davidian

Limitation of '781 Patent Claim 17	Automotive Electronics Handbook (Jurgen)	German Patent Application Publication No. 29 26 070 (Volkswagen '070)	U.S. Patent No. 5,357,438 (Davidian)
<p>17. Apparatus for optimizing operation of a vehicle, comprising:</p>	<p>E.g., page 12.1, “The electronic engine control system consists of sensing devices which continuously measure the operating conditions of the engine, <i>an electronic control unit (ECU) which evaluates the sensor inputs using data tables and calculations and determines the output to the actuating devices</i>, and actuating devices which are commanded by the ECU to perform an action in response to the sensor inputs.</p> <p>The motive for using an electronic engine control system is to provide the needed accuracy and adaptability in order to minimize exhaust emissions and fuel consumption, <i>provide optimal driveability for all operating conditions</i>, minimize evaporative emissions, and provide system diagnosis when malfunctions occur.”</p>	<p>E.g., page 5 (English translation), “The present invention is based on the objective of providing <i>a device that assists the operator of the internal combustion engine equipped with a conventional transmission</i>, i.e., the driver of a motor vehicle, for example, in setting an operating point of the engine that is advantageous in terms of consumption, by way of gear shift operations.”</p>	<p>E.g., col. 1, lines 1 to 2, “The present invention relates to <i>an anti-collision system for vehicles</i>.”</p>
<p>a radar detector, said radar detector determining a distance separating a vehicle having an engine and an object in front of said vehicle;</p>	<p>E.g., page 7.23, “Ultrasonics, infrared, laser, and <i>microwaves (radar) can be used in the detection of objects behind vehicles and in the blind areas</i>.”</p>		<p>E.g., col. 4, lines 52 to 66, “<i>Vehicle 2 further includes a front space sensor 8 for sensing the space in front of the vehicle, such as the presence of another vehicle, a corresponding rear space sensor 10, and a pair of side sensors 11</i>. All the space sensors are in the form of pulse (e.g., ultrasonic) transmitters and receivers, for determining the distance of the vehicle from an object, e.g., another vehicle, at front or rear. Space sensors may also be provided at the sides of the vehicle. Vehicle 2 is further equipped with a speed sensor 12 which may sense the speed of the vehicle in any known manner, for example using the speed measuring system of the vehicle itself, or a speed measuring system independent of the vehicle, e.g., an acceleration sensor, or by calculations based on</p>

Limitation of '781 Patent Claim 17	Automotive Electronics Handbook (Jurgen)	German Patent Application Publication No. 29 26 070 (Volkswagen '070)	U.S. Patent No. 5,357,438 (Davidian)
			<p>the Doppler effect, etc.”</p> <p>E.g., col. 10, lines 17 to 26, “FIG. 7 is a circuit diagram of the microcomputer 4 and the other components of the electrical system. The microprocessor is indicated by block 100, its power supply by block 102, and its watchdog circuit by block 104. <i>It includes a transmitter 106 and a receiver 108 for transmitting and receiving the pulses (e.g., RF, ultrasound, laser, IR, etc.) in the front space sensor 8 and the rear space sensor 10 for measuring the distance of the vehicle from objects in front of, and to the rear, of the vehicle, respectively.</i>”</p> <p>E.g., col. 10, lines 38 to 50, “As indicated earlier, the distance of the vehicle from an object is determined by the front space sensor 8 with respect to objects in front of the vehicle, and by the rear space sensor 10 with respect to objects at the rear of the vehicle. Each of these space sensors may be of known construction, including a transmitter as indicated at 106 in FIG. 7, and a receiver as indicated at 108. <i>Thus, pulses are continuously transmitted by each transmitter, and the echoes from the objects in front of or to the rear of the vehicle are received by the respective receiver. The computer then measures the round-trip time from the pulse transmission to the echo reception in order to determine the distance of the vehicle from the object.</i>”</p>
at least one sensor coupled to said vehicle for monitoring operation thereof,	E.g., page 7.6, “There are several applications for rotational speed sensing. <i>First it is necessary to monitor engine speed.</i> This information is used for transmission control, engine control, cruise control, and possibly for a tachometer.	E.g., page 6 (English translation), “As can be seen when viewing Figure 1 to begin with, output N of the engine has been plotted across engine speed n. a is the curve of the output at full load, b is a line that represents a constant setting of the	E.g., col. 4, lines 60 to 66, “Vehicle 2 is further equipped with <i>a speed sensor 12 which may sense the speed of the vehicle in any known manner</i> , for example using the speed measuring system of the vehicle itself, or a speed measuring system

Limitation of '781 Patent Claim 17	Automotive Electronics Handbook (Jurgen)	German Patent Application Publication No. 29 26 070 (Volkswagen '070)	U.S. Patent No. 5,357,438 (Davidian)
<p>said at least one sensor including a road speed sensor, a manifold pressure sensor, a throttle position sensor and an engine speed sensor;</p>	<p>Electronics and electronic sensing in the automobile were brought about by the need for higher efficiency engines, better fuel economy, increased power and performance, and lower emissions. Second, <i>wheel speed sensing is required</i> for use in transmissions, cruise control, speedometers, antilock brake systems (ABS), traction control (ASR), variable ratio power steering assist, four-wheel steering, and possibly in inertial navigation and air bag deployment applications.”</p> <p>E.g., page 7.8, “In electronic transmission applications, <i>information from the road and engine speed sensors</i>, as well as torque data and throttle position are required for the MCU to select the optimum gear ratio.”</p> <p>E.g., page 2.5, “Automotive specification and testing guidelines have been developed and published by the Society of Automotive Engineers (SAE) specifically for <i>manifold absolute pressure (MAP) sensors</i>.”</p> <p>E.g., page 2.7, “Manifold absolute pressure (MAP) is used as an input to fuel and ignition control in internal combustion engine control systems. <i>The speed-density system that uses the MAP sensor</i> has been preferred over mass air flow (MAF) control because it's less expensive, but stricter emission standards are causing more manufacturers to use mass air flow for future models.”</p> <p>E.g., page 12.18, “To control the idle speed, the ECU uses inputs from the <i>throttle position</i></p>	<p>output control element, i.e., a line that represents a constant <i>throttle valve angle</i> in a carburetor engine. As a measure thereof, in addition to the <i>throttle valve angle</i> itself, it is also possible to use the <i>induction manifold vacuum</i>. . . . The operating ranges I and II are further delimited by <i>engine speed</i> values <math>n_1</math> or <math>n_2</math>, the first of which usually lies between approximately 20 to 50% of the maximum engine speed, and the second usually lies between approximately 40 and 70% of the maximum engine speed.”</p> <p>E.g., page 8 (English translation), “<i>The engine speed signal is obtained with the aid of known sensor systems</i>, which therefore need not be described in further detail here.”</p> <p>E.g., page 9 (English translation), “It is useful if in addition to this device, a display of the route-specific fuel consumption is provided in a vehicle. Such display devices are known per se; they generally utilize the <i>injection manifold vacuum</i> as a measure of fuel consumption.”</p>	<p>independent of the vehicle, e.g., an acceleration sensor, or by calculations based on the Doppler effect, etc.”</p>

Limitation of '781 Patent Claim 17	Automotive Electronics Handbook (Jurgen)	German Patent Application Publication No. 29 26 070 (Volkswagen '070)	U.S. Patent No. 5,357,438 (Davidian)
	<p><i>sensor</i>, air conditioning, automatic transmission, power steering, charging system, engine RPM, and vehicle speed.”</p> <p>E.g., page 12.21, “The electronic injection unit also houses the <i>throttle position sensor</i> and, in some cases, an inlet air temperature sensor which provides operating condition information to the ECU.”</p>		
<p>a processor subsystem, coupled to said radar detector and said at least one sensor, to receive data therefrom;</p>	<p>E.g., page 12.1, “The electronic engine control system consists of <i>sensing devices which continuously measure the operating conditions of the engine, an electronic control unit (ECU) which evaluates the sensor inputs</i> using data tables and calculations and determines the output to the actuating devices, and actuating devices which are commanded by the ECU to perform an action in response to the sensor inputs.”</p> <p>E.g., page 22.6, “During the entire operating time of the vehicle, <i>the ECUs are constantly supervising the sensors they are connected to.</i>”</p> <p>E.g., page 13.4, “On the functional side, the hardware configuration can be divided into power supply, input signal transfer circuits, output stages, and <i>microcontroller</i>, including peripheral components and monitoring and safety circuits (Fig. 13.1).”</p> <p>E.g., Figure 13.1:</p>	<p>E.g., pages 7 to 8 (English translation), “<i>The two control circuits 2 and 3 are selectively closed by engine-speed dependent change-over switch 6, to which a signal that corresponds to the individual engine speed <math>n_1</math> is forwarded</i> and which is developed in such a way that at engine speeds that are greater than predefined engine speed <math>n_1</math> (see Figure 1), its shift lever pivots upwardly in Figure 2, but at engine speeds that are smaller than predefined engine speed <math>n_2</math>, it pivots in the downward direction from a neutral center position, which it therefore assumes when engine speed values between <math>n_1</math> and <math>n_2</math> are present.”</p> <p>E.g., Figure 2:</p>	<p>E.g., col. 8, lines 29 to 43, “<i>FIGS. 6a, 6b, are a block diagram illustrating the microcomputer 4 and its inputs and outputs described earlier which enable it to continuously monitor the operation of the vehicle</i> and to actuate first a Safety alarm, and then a Collision alarm whenever the vehicle may enter a danger-of-collision situation according to the various preset parameters and automatic parameters introduced into the computer.</p> <p><i>The microcomputer 4 as illustrated in FIGS. 6a, 6b is divided into various functional modules, as follows: a calculation module 90, which receives data concerning the various parameters briefly described above</i> and as will be described more particularly below to enable it to make the necessary computations for actuating the Safety alarm and the Collision alarm.”</p> <p>E.g., col. 8, lines 58 to 60, “Thus, module 90 receives inputs from the front space sensor 8, the rear space sensor 10, and the vehicle speed sensor 12.”</p> <p>E.g., Figure 6A:</p>

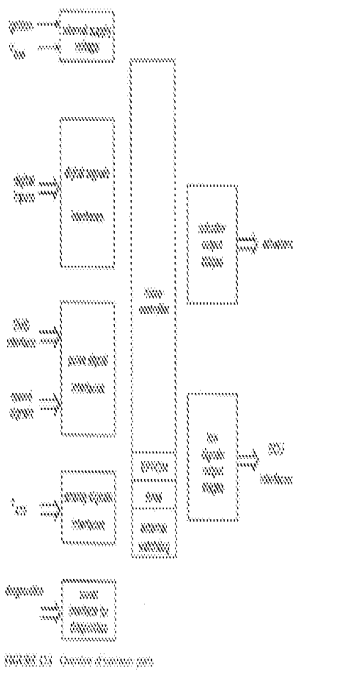
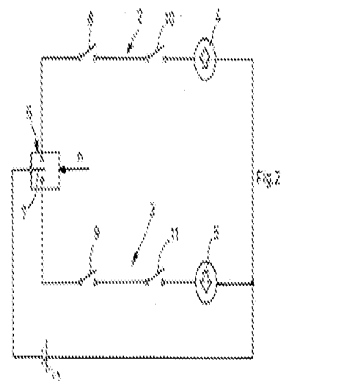
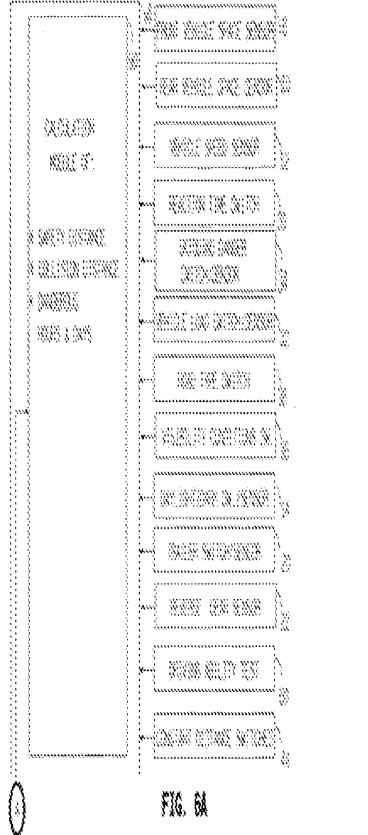
Limitation of '781 Patent Claim 17	Automotive Electronics Handbook (Jurgen)	German Patent Application Publication No. 29 26 070 (Volkswagen '070)	U.S. Patent No. 5,357,438 (Davidian)
	 <p>E.g., page 14.3, "The speed sensor is one of the most critical parts in the system, because the <i>microcontroller calculates the vehicle speed from the speed sensor's signal</i> to within 1/32 m/h."</p>		 <p>E.g., col. 9, lines 20 to 27, "<i>Computer module 90 also includes information about the vehicle braking distances as a function of speed. This is preferably in the form of a look-up table</i>, for example, provided by the manufacturer for predetermined defined conditions concerning road type, skidding danger, vehicle load and tires pressure, and is <i>stored in a ROM (read-only memory) of the microcomputer so that it can be changed periodically if necessary.</i>"</p> <p>E.g., col. 12, line 59 to col 13, line 22, "The system</p>
<p>a memory subsystem, coupled to said processor subsystem, said memory subsystem storing a first vehicle speed/stopping distance table, a manifold pressure set point, an RPM</p>	<p>E.g., page 13.5, "The calculators inside the control units are usually microcontrollers. . . . <i>The memory devices for program and data are usually EPROMS.</i> Their storage capacity is, in present applications, up to 64 Kbytes. Future applications will necessitate storage sizes up to 128 Kbytes. The failure storages for diagnostics and the storage for adaptive data are in conventional applications, battery voltage-supplied RAMs. These are increasingly being replaced by EEPROMs."</p>	<p>E.g., page 6 (English translation), "As can be seen when viewing Figure 1 to begin with, <i>output N of the engine has been plotted across engine speed n.</i>"</p> <p>E.g., page 6 (English translation), "<i>The numerical values of the limits of the two operating ranges I and II are of course dependent on the individual situation.</i> In general, it can be said that these two operating ranges lie in such a way that by shift operations, it is possible to achieve operating points in the</p>	<p>E.g., col. 9, lines 20 to 27, "<i>Computer module 90 also includes information about the vehicle braking distances as a function of speed. This is preferably in the form of a look-up table</i>, for example, provided by the manufacturer for predetermined defined conditions concerning road type, skidding danger, vehicle load and tires pressure, and is <i>stored in a ROM (read-only memory) of the microcomputer so that it can be changed periodically if necessary.</i>"</p> <p>E.g., col. 12, line 59 to col 13, line 22, "The system</p>

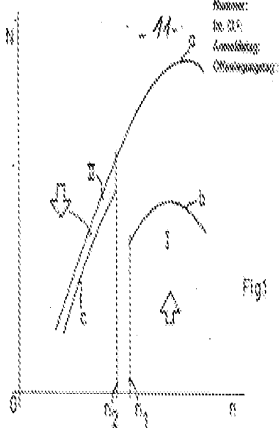
Limitation of '781 Patent Claim 17	Automotive Electronics Handbook (Jurgen)	German Patent Application Publication No. 29 26 070 (Volkswagen '070)	U.S. Patent No. 5,357,438 (Davidian)
<p>set point, a present level for each one of said at least one sensor and a prior level for each one of said at least one sensor;</p>	<p>E.g., page 12.9, "A subsystem of the fuel control system is lambda closed-loop control. . . .</p> <p>[T]he engine control unit uses an anticipatory control strategy that uses engine load and RPM to determine the approximate fuel requirement. <i>The engine load information is provided by the manifold pressure sensor for speed density systems and by the air meter for air flow and air mass measurement systems and by the throttle valve position sensor. The engine control unit contains data tables for combinations of load and RPM.</i> This allows for rapid response to changes in operating conditions. The lambda sensor still provides the feedback correction for each load/RPM point. . . .</p> <p>[T]he electronic control unit has a feature for adapting changes in the fuel required for the load/RPM points. <i>At each load/RPM point, the lambda sensor continuously provides information that allows the system to adjust the fuel to the commanded A/F ratio. The corrected information is stored in RAM (random access memory) so that the next time the engine reaches that operating point (load/RPM), the anticipatory value will require less correction. These values remain stored in the electronic control unit even after the engine is shut off.</i> Only if power to the electronic control unit is disrupted (i.e., due to a dead battery), will the correction be lost. In that case, the electronic control unit will revert back to the original production values that are written in ROM (read-only memory)."</p> <p>E.g., page 14.2, "Other safety-related items</p>	<p>output/engine speed diagram that are more favorable in terms of fuel consumption."</p> <p>E.g., page 8 (English translation), "<b>Furthermore, to define the two operating ranges I and II, load-dependent switches 8 and 9 are provided in control circuits 2 and 3 in Figure 2, the first of which is closed only below the line denoted by b in Figure 1, and switch 9 is closed only above the line denoted by c in Figure 1.</b>"</p> <p>E.g., Figure 1:</p> 	<p>then makes the computations illustrated (as an example) in block 162 to determine the stopping distance SD, which is equal to the reaction distance plus the braking distance multiplied by a stopping factor ST and a safety factor SF. <b>In the illustrated example, the stopping distance is the sum of the reaction distance and the braking distance. The reaction distance is the product of the reaction time, visibility condition, daylight condition, reaction factor and speed; and the braking distance is the product of the braking distance (as supplied by the manufacturer), road type, skidding danger, vehicle load and braking factor.</b> The stopping distance (SD) includes further safety factors, and determines when the safety alarm will be actuated to first alert the driver of an approaching collision danger.</p> <p><b>A determination is also made of the collision distance CD which is equal to the stopping distance SD divided by the collision safety factor CSF, e.g., 1.25 in the example illustrated above, such that should the distance between the vehicle and the object come within the collision distance CD, the collision alarm is then actuated.</b></p> <p>The foregoing calculations of stopping distance SD and collision distance CD with respect to objects at the front of the vehicle are also made with respect to objects at the rear of the vehicle, these calculations being RSD and RCD, respectively, also shown in block 162.</p> <p>Whenever the distance between the vehicle and an object to the front of the vehicle or to the rear of the vehicle comes within the stopping distance SD and the collision distance CD, the system operates</p>

Limitation of '781 Patent Claim 17	Automotive Electronics Handbook (Jurgen)	German Patent Application Publication No. 29 26 070 (Volkswagen '070)	U.S. Patent No. 5,357,438 (Davidian)
	<p>include <i>program code to detect abnormal operating conditions and preserving into memory the data points associated with the abnormal condition for later diagnostics.</i> Abnormal conditions, for example, could be an intermittent vehicle speed sensor, or erratic driver switch signals.”</p> <p>E.g., pages 22.2 to 22.3, “The most important test points of control units and sensors are tied to a diagnostic connector which is plugged into the measuring instrument with a corresponding adapter for the respective vehicle. . . .</p> <p><i>Modern electronics in vehicles support diagnosis by comparing the registered actual value with the internally stored nominal values with the help of control units and their self-diagnosis, thus detecting faults.</i>”</p>		<p>according to the deceleration alarm module 93, as indicated by block 164.”</p>
<p>a vehicle proximity alarm circuit coupled to said processor subsystem, said vehicle proximity alarm circuit issuing an alarm that said vehicle is too close to said object;</p>	<p>E.g., page 7.6, “[W]heel speed sensing is required for use in transmissions, cruise control, speedometers, antilock brake systems (ABS), traction control (ASR), variable ratio power steering assist, four-wheel steering, and possibly in inertial navigation and air bag deployment applications.</p> <p>Linear speed sensing can be used to measure the ground speed. This measurement also has the possibly of use in ABS, ASR, and inertial navigation. <i>Similar types of sensors can be used in crash avoidance, proximity, and obstacle detection applications.</i>”</p> <p>E.g., page 7.23, “Ultrasonics, infrared, laser, and microwaves (radar) can be used in the detection of objects behind vehicles and in the blind areas.”</p>		<p>E.g., col. 3, lines 59 to 66, “The anti-collision system illustrated in FIGS. 1-14 is particularly useful for motor vehicles (passengers cars, buses, trucks) in order to <i>actuate an alarm when the vehicle is travelling at a distance behind another vehicle or in front of another</i>, which is equal to or less than a danger-of-collision distance computed by a computer such that if the front vehicle stops suddenly there is a danger of a rear-end collision.”</p> <p>E.g., col. 4, lines 14 to 16, “In the system described below, <i>there are two alarms: a Collision alarm, which is actuated when the vehicle is determined to be within the danger-of-collision distance; and a Safety alarm, which is actuated before the Collision alarm, at a distance greater than the danger-of-collision distance by a predetermined safety factor, e.g., 1.25.</i>”</p>

Limitation of '781 Patent Claim 17	Automotive Electronics Handbook (Jurgen)	German Patent Application Publication No. 29 26 070 (Volkswagen '070)	U.S. Patent No. 5,357,438 (Davidian)
			<p>E.g., col. 6, lines 25 to 29, "Control panel 6 further includes a front distance display 46, in which are displayed the distance to the front vehicle (in region 46a), in which direction (by arrow 46b), and <i>whether or not there is a collision danger (region 46c).</i>"</p> <p>E.g., col. 6, lines 41 to 46, "Control panel 6 further includes a speaker 54 for producing an <i>audio alarm in the event of a collision danger, in addition to the visually-indicated alarms</i> of sections 46c and 48c of the displays 46 and 48."</p> <p>E.g., col. 8, lines 37 to 48, "The <i>microcomputer 4</i> as illustrated in FIGS. 6a, 6b is divided into various functional modules, as follows: ... <i>a deceleration alarm module 93, which controls the Safety alarm and Collision alarm on the control panel, ...</i>"</p> <p>E.g., Figs. 3 and 6B (ref. no. 46C)</p>
<p>a fuel overinjection circuit coupled to said processor subsystem, said fuel overinjection circuit issuing a notification that excessive fuel is being supplied to said engine of said vehicle;</p>	<p>E.g., page 12.22, "During an acceleration transition, the ECU adds a correction factor (an increase) to the commanded injector pulse width. The sudden increase in air results in a lean mixture which must be corrected swiftly to obtain good transitional response. <i>During a deceleration transition, the fuel can be shut off by simply not providing a pulse width signal to the injector to minimize exhaust emissions and fuel consumption.</i>"</p> <p>E.g., page 12.4, "During coasting and braking, fuel consumption can be further reduced by shutting off the fuel until the engine speed</p>	<p>E.g., page 9 (English translation), "It is useful if in addition to this device, <i>a display of the route-specific fuel consumption is provided in a vehicle.</i> Such display devices are known per se; they generally utilize the injection manifold vacuum as a measure of fuel consumption."</p>	

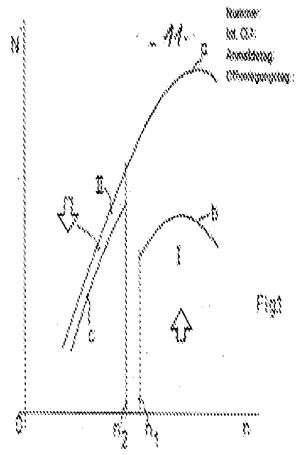

Limitation of '781 Patent Claim 17	Automotive Electronics Handbook (Jurgen)	German Patent Application Publication No. 29 26 070 (Volkswagen '070)	U.S. Patent No. 5,357,438 (Davidian)
	<p>decreases to slightly higher than the set idle speed. <i>The ECU determines when fuel shutoff can occur by evaluating the throttle position, engine RPM, and vehicle speed.</i></p> <p>E.g., page 12.14, "Using the inputs of engine RPM and vehicle speed to the electronic control unit, thresholds can be established for limiting these variables with fuel cutoff. <i>When the maximum speed is achieved, the fuel injectors are shut off.</i> When the speed decreases below the threshold, fuel injection resumes."</p> <p>E.g., page 12.17, "<i>During transition to fuel cutoff, the ignition timing is retarded from its current setting to reduce engine torque and to assist in engine braking. The fuel is then shut off.</i> During the transition, the throttle bypass valve or the main throttle valve may remain open for a short period to allow fresh air to oxidize the remaining unburned HC and CO to further reduce exhaust emissions. During development of the fuel cutoff strategy, the advantage of reduced emission effects and catalyst temperature control must be balanced against driveability requirements. The use of fuel cutoff may change the perceived amount of engine braking felt by the driver. In addition, care must be taken to avoid a 'bump' feel when entering the fuel cutoff mode, due to the change in torque."</p>		
an upshift notification circuit coupled to said processor subsystem, said upshift	E.g., page 13.7 to 13.9, " <i>The basic functions of the transmission control are the shift point control, the lockup control, engine torque control during shifting, related safety functions, and diagnostic functions for vehicle service.</i> "	E.g., pages 6 to 7 (English translation), "Looking initially at operating range I remote from full load, <i>the desired output at a lower specific fuel consumption is able to be achieved after upshifting into the next higher gear,</i> at an operating point that lies to the left of operating	

Limitation of '781 Patent Claim 17	Automotive Electronics Handbook (Jurgen)	German Patent Application Publication No. 29 26 070 (Volkswagen '070)	U.S. Patent No. 5,357,438 (Davidian)
<p>notification circuit issuing a notification that said engine of said vehicle is being operated at an excessive speed;</p>	<p>E.g., page 13.9, "The basic shift point control uses shift maps, which are defined in data in the unit memory. These shift maps are selectable over a wide range. <i>The shift point limitations are made, on the one hand, by the highest admissible engine speed for each application and, on the other hand, by the lowest engine speed that is practical for driving comfort and noise emission. The inputs of the shift point determination are the throttle position, the accelerator pedal position, and the vehicle speed (determined by the transmission output speed).</i>"</p> <p>E.g., page 13.14, "In addition to these functions, <i>different shift maps can be implemented into the data field of the TCU [Transmission Control Unit].</i> For example, it is possible to have one shift map for low fuel consumption, which has shift points in the range of the best efficiency of the engine, and additionally to have another map for power operation, where the shift points are placed at points of highest engine output power."</p>	<p>range I in the diagram of Figure 1. <i>Accordingly, the device of the present invention generates a signal that asks the operator, i.e., normally the driver, to shift to a higher gear, which is indicated in Figure 1 by the upward pointing arrow within operating range I.</i>"</p> <p>E.g., pages 7 to 8 (English translation), "The two control circuits 2 and 3 are selectively closed by engine-speed dependent change-over switch 6, to which a signal that corresponds to the individual engine speed <math>n</math> is forwarded and which is developed in such a way that <i>at engine speeds that are greater than predefined engine speed <math>n_1</math> (see Figure 1), its shift lever pivots upwardly in Figure 2, but at engine speeds that are smaller than predefined engine speed <math>n_2</math>, it pivots in the downward direction from a neutral center position, which it therefore assumes when engine speed values between <math>n_1</math> and <math>n_2</math> are present.</i>"</p> <p>E.g., Figure 1:</p>  <p>E.g., Figure 2:</p>	



Limitation of '781 Patent Claim 17	Automotive Electronics Handbook (Jurgen)	German Patent Application Publication No. 29 26 070 (Volkswagen '070)	U.S. Patent No. 5,357,438 (Davidian)
	<p>uses shift maps, which are defined in data in the unit memory. These shift maps are selectable over a wide range. <i>The shift point limitations are made</i>, on the one hand, by the highest admissible engine speed for each application and, on the other hand, <i>by the lowest engine speed that is practical for driving comfort and noise emission. The inputs of the shift point determination are the throttle position, the accelerator pedal position, and the vehicle speed (determined by the transmission output speed).</i>"</p>	<p><i>downward direction from a neutral center position</i>, which it therefore assumes when engine speed values between <math>n_1</math> and <math>n_2</math> are present."</p> <p>E.g., page 7 (English translation), "<i>When the operating point lies in operating range II, the device according to the present invention generates a signal that asks the driver to downshift, which is indicated by the downward pointing arrow at operating range II in Figure 1.</i>"</p> <p>E.g., page 9 (English translation), "It is useful if in addition to this device, <i>a display of the route-specific fuel consumption</i> is provided in a vehicle. Such display devices are known per se; they generally utilize the <i>injection manifold vacuum</i> as a measure of fuel consumption."</p>	<p>vehicle load and braking factor. <i>The stopping distance (SD) includes further safety factors, and determines when the safety alarm will be actuated to first alert the driver of an approaching collision danger.</i></p> <p><i>A determination is also made of the collision distance CD which is equal to the stopping distance SD divided by the collision safety factor CSF, e.g., 1.25 in the example illustrated above, such that should the distance between the vehicle and the object come within the collision distance CD, the collision alarm is then actuated.</i>"</p> <p>E.g., col. 13, lines 17 to 22, "<i>Whenever the distance between the vehicle and an object to the front of the vehicle or to the rear of the vehicle comes within the stopping distance SD and the collision distance CD, the system operates according to the deceleration alarm module 93, as indicated by block 164.</i>"</p>

Limitation of '781 Patent Claim 18	Automotive Electronics Handbook (Jurgen)	German Patent Application Publication No. 29 26 070 (Volkswagen '070)	U.S. Patent No. 5,357,438 (Davidian)
18. Apparatus for optimizing operation of a vehicle according to claim 17 wherein:	See claim 17 claim chart, at page A-104.	See claim 17 claim chart, at page A-104.	See claim 17 claim chart, at page A-104.
said at least one sensor further includes a windshield wiper sensor for indicating whether a windshield wiper of said vehicle is activated; and			<p>E.g., col. 4, line 67 to col. 5, line 2, "The automatic sensors on vehicle 2 further include a daylight sensor 14, <i>a rain sensor 16</i>, a vehicle load sensor 18, a trailer-hitch sensor 20, and a reverse gear sensor 22."</p> <p>E.g., col. 8, lines 58 to 63, "Thus, module 90 receives inputs from the front space sensor 8, the rear space sensor 10, and the vehicle speed sensor 12. <i>Module 90 also receives inputs from the sensors in case there is no depressible key, e.g., the daylight sensor 14, the trailer sensor 20, the reverse gear sensor 22, the rain sensor 16, and the vehicle load sensor 18.</i>"</p>
said memory subsystem further storing a second vehicle speed/stopping distance table.			<p>E.g., col. 9, lines 20 to 27, "<i>Computer module 90 also includes information about the vehicle braking distances as a function of speed. This is preferably in the form of a look-up table</i>, for example, provided by the manufacturer for predetermined defined conditions concerning road type, skidding danger, vehicle load and tires pressure, and is <i>stored in a ROM (read-only memory) of the microcomputer so that it can be changed periodically if necessary.</i>"</p> <p>E.g., col. 12, line 59 to col 13, line 22, "The system then makes the computations illustrated (as an example) in block 162 to determine the stopping distance SD, which is equal to the reaction distance plus the braking distance multiplied by a stopping factor ST and a safety factor SF. <i>In the illustrated example, the stopping distance is the sum of the</i></p>

Limitation of '781 Patent Claim 18	Automotive Electronics Handbook (Jurgen)	German Patent Application Publication No. 29 26 070 (Volkswagen '070)	U.S. Patent No. 5,357,438 (Davidian)
			<p><i>reaction distance and the braking distance.</i> The reaction distance is the product of the reaction time, visibility condition, daylight condition, reaction factor and speed; and <i>the braking distance is the product of the braking distance (as supplied by the manufacturer),</i> road type, <i>skidding danger,</i> vehicle load and braking factor. The stopping distance (SD) includes further safety factors, and determines when the safety alarm will be actuated to first alert the driver of an approaching collision danger.</p> <p>A determination is also made of the collision distance CD which is equal to the stopping distance SD divided by the collision safety factor CSF, e.g., 1.25 in the example illustrated above, such that should the distance between the vehicle and the object come within the collision distance CD, the collision alarm is then actuated.</p> <p>The foregoing calculations of stopping distance SD and collision distance CD with respect to objects at the front of the vehicle are also made with respect to objects at the rear of the vehicle, these calculations being RSD and RCD, respectively, also shown in block 162.</p> <p>Whenever the distance between the vehicle and an object to the front of the vehicle or to the rear of the vehicle comes within the stopping distance SD and the collision distance CD, the system operates according to the deceleration alarm module 93, as indicated by block 164.”</p>

Limitation of '781 Patent Claim 19	Automotive Electronics Handbook (Jurgen)	German Patent Application Publication No. 29 26 070 (Volkswagen '070)	U.S. Patent No. 5,357,438 (Davidian)
19. Apparatus for optimizing operation of a vehicle according to claim 17 and further comprising:	See claim 17 claim chart, at page A-104.	See claim 17 claim chart, at page A-104.	See claim 17 claim chart, at page A-104.
a throttle controller for controlling a throttle of said engine of said vehicle; and	E.g., page 14.4, "When the error signal has been computed, <i>an output signal to the servo actuators is generated to increase, hold, or decrease the throttle position.</i> . . . Throttle positioning is traditionally either a vacuum type servo or motor."	E.g., page 7 (English translation), "The position of the operating point of the engine is in operation range II close to full load, i.e., to the left of engine speed $n_2$ in Figure 1, first of all has the basic disadvantage that the desired higher output is not obtained despite the fact that the <i>accelerator pedal</i> or the <i>output control element is in the full throttle position.</i> "	E.g., col. 2, line 67 to col. 3, line 2, "According to a further feature, the system includes an actuator for actuating a mechanical system of the vehicle, e.g., <i>the brakes of a train</i> , or steering of an aircraft, at the time the collision alarm is actuated."
said processor subsystem selectively reducing said throttle based upon data received from said radar detector, said at least one sensor and said memory subsystem.			<p>E.g., col. 2, line 67 to col. 3, line 2, "According to a further feature, the system includes an actuator for actuating a mechanical system of the vehicle, e.g., <i>the brakes of a train</i>, or steering of an aircraft, at the time the collision alarm is actuated."</p> <p>E.g., col. 8, lines 37 to 43, "The <i>microcomputer 4</i> as illustrated in FIGS. 6a, 6b is divided into various functional modules, as follows: a calculation module 90, <i>which receives data concerning the various parameters briefly described above</i> and as will be described more particularly below <i>to enable it to make the necessary computations for actuating the Safety alarm and the Collision alarm; ...</i>"</p> <p>E.g., col. 12, line 59 to col 13, line 11, "The system then makes the computations illustrated (as an example) in block 162 to determine the stopping distance SD, which is equal to the reaction distance plus the braking distance multiplied by a stopping factor ST and a safety factor SF. In the illustrated</p>

Limitation of '781 Patent Claim 19	Automotive Electronics Handbook (Jürgen)	German Patent Application Publication No. 29 26 070 (Volkswagen '070)	U.S. Patent No. 5,357,438 (Davidian)
			<p>example, the stopping distance is the sum of the reaction distance and the braking distance. The reaction distance is the product of the reaction time, visibility condition, daylight condition, reaction factor and speed; and the braking distance is the product of the braking distance (as supplied by the manufacturer), road type, skidding danger, vehicle load and braking factor. <i>The stopping distance (SD) includes further safety factors, and determines when the safety alarm will be actuated to first alert the driver of an approaching collision danger.</i></p> <p><i>A determination is also made of the collision distance CD which is equal to the stopping distance SD divided by the collision safety factor CSF, e.g., 1.25 in the example illustrated above, such that should the distance between the vehicle and the object come within the collision distance CD, the collision alarm is then actuated."</i></p> <p>E.g., col. 13, lines 17 to 22, "<i>Whenever the distance between the vehicle and an object to the front of the vehicle or to the rear of the vehicle comes within the stopping distance SD and the collision distance CD, the system operates according to the deceleration alarm module 93, as indicated by block 164.</i>"</p>



Limitation of '781 Patent Claim 20	Automotive Electronics Handbook (Jurgen)	German Patent Application Publication No. 29 26 070 (Volkswagen '070)	U.S. Patent No. 5,357,438 (Davidian)
20. Apparatus for optimizing operation of a vehicle according to claim 19 wherein	See claim 19 claim chart, at page A-118.	See claim 19 claim chart, at page A-118.	See claim 19 claim chart, at page A-118.
said at least one sensor further includes a brake sensor for indicating whether a brake system of said vehicle is activated.	E.g., pages 7.21 to 22, "In antilock brake systems, speed sensors are attached to all wheels to determine wheel rotation speed and slip differential between wheels . . . <b><i>Brake pedal position and brake fluid pressure information are also required for control.</i></b> "		E.g., col. 6, lines 25 to 34, "Control panel 6 further includes a front distance display 46, in which are displayed the distance to the front vehicle (in region 46a), in which direction (by arrow 46b), and whether or not there is a collision danger (region 46c). A similar display, shown at 48 and having regions 48a, 48b and 48c, is provided with respect to the rear of the vehicle equipped with the system, whether a rear collision danger exists, and <b><i>the status of the rear brake light.</i></b> "  E.g., col. 8, lines 37 to 57, "The microcomputer 4 as illustrated in FIGS. 6a, 6b is divided into various functional modules, as follows: . . . a deceleration alarm module 93, which controls the Safety alarm and Collision alarm on the control panel, <b><i>the brake light actuator 26 and (e.g., in the case of a train) the vehicle brakes automatically;</i></b> a black box module 94, which controls the information recorded into and read out of the black box 28; and a driving ability test module 95, involved in the driving ability test 60 in the control panel of FIG. 2, or 80 in the control panel of FIG. 5. The operation of each of these modules (except the clock 91) is described more particularly below with reference to the flow charts of FIGS. 9-14."

Limitation of '781 Patent Claim 21	Automotive Electronics Handbook (Jurgen)	German Patent Application Publication No. 29 26 070 (Volkswagen '070)	U.S. Patent No. 5,357,438 (Davidian)
21. Apparatus for optimizing operation of a vehicle according to claim 19 wherein said processor subsystem further comprises:	See claim 19 claim chart, at page A-118.	See claim 19 claim chart, at page A-118.	See claim 19 claim chart, at page A-118.
means for counting a total number of vehicle proximity alarms determined by said processor subsystem;			<p>E.g., col. 11, lines 7 to 11, "ALSF Alarm stopping front counter; ALSR Alarm stopping rear counter; ALCF Alarm collision front counter; ALCR Alarm collision rear counter."</p> <p>E.g., col. 11, lines 60 to 68, "The ALSF and ALSR counters, the ALCF and ALCR counters, and the ALFA and ALRA accumulators in the above table, and referred to in the flow charts below, would be provided in the black box 28 which records all the incidents in which the safety alarm and collision alarm were actuated, including the time, vehicle speed and vehicle distance for each alarm incident."</p> <p>E.g., col. 14, lines 8 to 12, "Whenever the measured distance is equal to or less than the stopping distance (block 225), the system increments the alarm stopping front counter (block 228), records the time, distance and speed in the black box, and also actuates the safety alarm (block 229)."</p>
means for selectively reducing said throttle based upon said total number of vehicle proximity alarms.			<p>E.g., col. 2, line 67 to col. 3, line 2, "According to a further feature, the system includes an actuator for actuating a mechanical system of the vehicle, e.g., <i>the brakes of a train</i>, or steering of an aircraft, at the time the collision alarm is actuated."</p> <p>E.g., col. 8, lines 37 to 43, "The <i>microcomputer 4</i> as illustrated in FIGS. 6a, 6b is divided into various functional modules, as follows: a calculation module 90, <i>which receives data concerning the various parameters</i></p>

Limitation of '781 Patent Claim 21	Automotive Electronics Handbook (Jurgen)	German Patent Application Publication No. 29 26 070 (Volkswagen '070)	U.S. Patent No. 5,357,438 (Davidian)
			<p><i>briefly described above and as will be described more particularly below to enable it to make the necessary computations for actuating the Safety alarm and the Collision alarm; ..."</i></p> <p>E.g., col. 12, line 59 to col 13, line 11, "The system then makes the computations illustrated (as an example) in block 162 to determine the stopping distance SD, which is equal to the reaction distance plus the braking distance multiplied by a stopping factor ST and a safety factor SF. In the illustrated example, the stopping distance is the sum of the reaction distance and the braking distance. The reaction distance is the product of the reaction time, visibility condition, daylight condition, reaction factor and speed; and the braking distance is the product of the braking distance (as supplied by the manufacturer), road type, skidding danger, vehicle load and braking factor. <i>The stopping distance (SD) includes further safety factors, and determines when the safety alarm will be actuated to first alert the driver of an approaching collision danger.</i></p> <p><i>A determination is also made of the collision distance CD which is equal to the stopping distance SD divided by the collision safety factor CSF, e.g., 1.25 in the example illustrated above, such that should the distance between the vehicle and the object come within the collision distance CD, the collision alarm is then actuated."</i></p> <p>E.g., col. 13, lines 17 to 22, "<i>Whenever the distance between the vehicle and an object to the front of the vehicle or to the rear of the vehicle comes within the stopping distance SD and the collision distance CD, the system operates according to the deceleration alarm module 93, as indicated by block 164.</i>"</p>

Limitation of '781 Patent Claim 22	Automotive Electronics Handbook (Jurgen)	German Patent Application Publication No. 29 26 070 (Volkswagen '070)	U.S. Patent No. 5,357,438 (Davidian)
22. Apparatus for optimizing operation of a vehicle according to claim 17 and further comprising:	See claim 17 claim chart, at page A-104.	See claim 17 claim chart, at page A-104.	See claim 17 claim chart, at page A-104.
a downshift notification circuit coupled to said processor subsystem, said downshift notification circuit issuing a notification that said engine of said vehicle is being operated at an insufficient engine speed; and	<p>E.g., page 13.7 to 13.9, "<i>The basic functions of the transmission control are the shift point control, the lockup control, engine torque control during shifting, related safety functions, and diagnostic functions for vehicle service.</i>"</p> <p>E.g., page 13.9, "The basic shift point control uses shift maps, which are defined in data in the unit memory. These shift maps are selectable over a wide range. <i>The shift point limitations are made, on the one hand, by the highest admissible engine speed for each application</i> and, on the other hand, by the lowest engine speed that is practical for driving comfort and noise emission. <i>The inputs of the shift point determination are the throttle position, the accelerator pedal position, and the vehicle speed</i> (determined by the transmission output speed)."</p> <p>E.g., page 13.14, "In addition to these functions, <i>different shift maps can be implemented into the data field of the TCU [Transmission Control Unit].</i> For example, it is possible to have one shift map for low fuel consumption, which has shift points in the range of the best efficiency of the engine, and additionally to have another map for power operation,</p>	<p>E.g., pages 6 to 7 (English translation), "Looking initially at operating range I remote from full load, <i>the desired output at a lower specific fuel consumption is able to be achieved after upshifting into the next higher gear</i>, at an operating point that lies to the left of operating range I in the diagram of Figure 1. <i>Accordingly, the device of the present invention generates a signal that asks the operator, i.e., normally the driver, to shift to a higher gear, which is indicated in Figure 1 by the upward pointing arrow within operating range I.</i>"</p> <p>E.g., pages 7 to 8 (English translation), "The two control circuits 2 and 3 are selectively closed by engine-speed dependent change-over switch 6, to which a signal that corresponds to the individual engine speed <math>n</math> is forwarded and which is developed in such a way that <i>at engine speeds that are greater than predefined engine speed <math>n_1</math> (see Figure 1), its shift lever pivots upwardly in Figure 2, but at engine speeds that are smaller than predefined engine speed <math>n_2</math>, it pivots in the downward direction from a neutral center position,</i> which it therefore assumes when engine speed values between <math>n_1</math> and <math>n_2</math> are present."</p> <p>E.g., Figure 1:</p>	

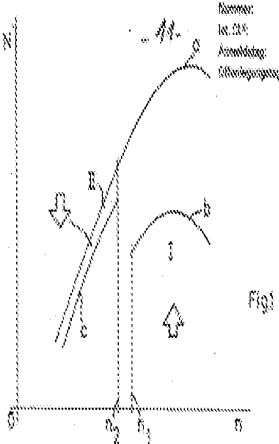
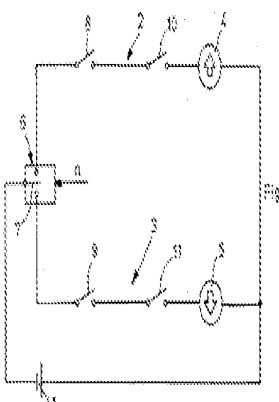
Limitation of '781 Patent Claim 22	Automotive Electronics Handbook (Jürgen)	German Patent Application Publication No. 29 26 070 (Volkswagen '070)	U.S. Patent No. 5,357,438 (Davidian)
	<p>where the shift points are placed at points of highest engine output power.”</p>	 <p>Fig. 1</p> <p>E.g., Figure 2:</p>  <p>Fig. 2</p>	
<p>said processor subsystem determining, based upon data received from said plurality of sensors, when to activate said downshift notification circuit.</p>	<p>E.g., page 12.4, “During coasting and braking, fuel consumption can be further reduced by shutting off the fuel until the engine speed decreases to slightly higher than the set idle speed. <i>The ECU determines when fuel shutoff can occur by evaluating the throttle position, engine RPM, and vehicle speed.</i>”</p> <p>E.g., page 12.14, “Using the inputs of</p>	<p>E.g., pages 6 to 7 (English translation), “Looking initially at operating range I remote from full load, the desired output at a lower specific fuel consumption is able to be achieved after upshifting into the next higher gear, at an operating point that lies to the left of operating range I in the diagram of Figure 1. Accordingly, the device of the present invention generates a signal that asks the operator, i.e., normally the driver, to shift to a</p>	<p>E.g., col. 8, lines 37 to 43, “The <i>microcomputer 4</i> as illustrated in FIGS. 6a, 6b is divided into various functional modules, as follows: a calculation module 90, which receives data concerning the various parameters briefly described above and as will be described more particularly below to enable it to make the necessary computations for actuating the Safety alarm and the Collision alarm; ...”</p> <p>E.g., col. 12, line 59 to col 13, line 11, “The system</p>

Limitation of '781 Patent Claim 22	Automotive Electronics Handbook (Jurgen)	German Patent Application Publication No. 29 26 070 (Volkswagen '070)	U.S. Patent No. 5,357,438 (Davidian)
	<p>engine RPM and vehicle speed to the electronic control unit, thresholds can be established for limiting these variables with fuel cutoff. <b>When the maximum speed is achieved, the fuel injectors are shut off.</b> When the speed decreases below the threshold, fuel injection resumes.”</p> <p>E.g., page 13.7 to 13.9, “<b>The basic functions of the transmission control are the shift point control</b>, the lockup control, engine torque control during shifting, related safety functions, and diagnostic functions for vehicle service.”</p> <p>E.g., page 13.9, “The basic shift point control uses shift maps, which are defined in data in the unit memory. These shift maps are selectable over a wide range. <b>The shift point limitations are made</b>, on the one hand, by the highest admissible engine speed for each application and, on the other hand, <b>by the lowest engine speed that is practical for driving comfort and noise emission. The inputs of the shift point determination are the throttle position, the accelerator pedal position, and the vehicle speed</b> (determined by the transmission output speed).”</p>	<p><b>higher gear, which is indicated in Figure 1 by the upward pointing arrow within operating range I.”</b></p> <p>E.g., pages 7 to 8 (English translation), “The two control circuits 2 and 3 are selectively closed by engine-speed dependent change-over switch 6, to which a signal that corresponds to the individual engine speed <math>n</math> is forwarded and which is developed in such a way that <b>at engine speeds that are greater than predefined engine speed <math>n_1</math> (see Figure 1), its shift lever pivots upwardly in Figure 2, but at engine speeds that are smaller than predefined engine speed <math>n_2</math>, it pivots in the downward direction from a neutral center position</b>, which it therefore assumes when engine speed values between <math>n_1</math> and <math>n_2</math> are present.”</p> <p>E.g., page 7 (English translation), “<b>When the operating point lies in operating range II, the device according to the present invention generates a signal that asks the driver to downshift, which is indicated by the downward pointing arrow at operating range II in Figure 1.</b>”</p>	<p>then makes the computations illustrated (as an example) in block 162 to determine the stopping distance SD, which is equal to the reaction distance plus the braking distance multiplied by a stopping factor ST and a safety factor SF. In the illustrated example, the stopping distance is the sum of the reaction distance and the braking distance. The reaction distance is the product of the reaction time, visibility condition, daylight condition, reaction factor and speed; and the braking distance is the product of the braking distance (as supplied by the manufacturer), road type, skidding danger, vehicle load and braking factor. <b>The stopping distance (SD) includes further safety factors, and determines when the safety alarm will be actuated to first alert the driver of an approaching collision danger.</b></p> <p><b>A determination is also made of the collision distance CD which is equal to the stopping distance SD divided by the collision safety factor CSF, e.g., 1.25 in the example illustrated above, such that should the distance between the vehicle and the object come within the collision distance CD, the collision alarm is then actuated.”</b></p> <p>E.g., col. 13, lines 17 to 22, “<b>Whenever the distance between the vehicle and an object to the front of the vehicle or to the rear of the vehicle comes within the stopping distance SD and the collision distance CD, the system operates according to the deceleration alarm module 93, as indicated by block 164.</b>”</p>

Limitation of '781 Patent Claim 23	Automotive Electronics Handbook (Jurgen)	German Patent Application Publication No. 29 26 070 (Volkswagen '070)	U.S. Patent No. 5,357,438 (Davidian)
<p>23. Apparatus for optimizing operation of a vehicle, comprising:</p>	<p>E.g., page 12.1, "The electronic engine control system consists of sensing devices which continuously measure the operating conditions of the engine, <i>an electronic control unit (ECU) which evaluates the sensor inputs using data tables and calculations and determines the output to the actuating devices</i>, and actuating devices which are commanded by the ECU to perform an action in response to the sensor inputs.</p> <p>The motive for using an electronic engine control system is to provide the needed accuracy and adaptability in order to minimize exhaust emissions and fuel consumption, <i>provide optimal driveability for all operating conditions</i>, minimize evaporative emissions, and provide system diagnosis when malfunctions occur."</p>	<p>E.g., page 5 (English translation), "The present invention is based on the objective of providing <i>a device that assists the operator of the internal combustion engine equipped with a conventional transmission</i>, i.e., the driver of a motor vehicle, for example, in setting an operating point of the engine that is advantageous in terms of consumption, by way of gear shift operations."</p>	<p>E.g., col. 1, lines 1 to 2, "The present invention relates to <i>an anti-collision system for vehicles.</i>"</p>
<p>a radar detector, said radar detector determining a distance separating a vehicle having an engine and an object in front of said vehicle;</p>	<p>E.g., page 7.23, "Ultrasonics, infrared, laser, and <i>microwaves (radar) can be used in the detection of objects behind vehicles and in the blind areas.</i>"</p>		<p>E.g., col. 4, lines 52 to 66, "<i>Vehicle 2 further includes a front space sensor 8 for sensing the space in front of the vehicle, such as the presence of another vehicle, a corresponding rear space sensor 10, and a pair of side sensors 11.</i> All the space sensors are in the form of pulse (e.g., ultrasonic) transmitters and receivers, for determining the distance of the vehicle from an object, e.g., another vehicle, at front or rear. Space sensors may also be provided at the sides of the vehicle. Vehicle 2 is further equipped with a speed sensor 12 which may sense the speed of the vehicle in any known manner, for example using the speed measuring system of the vehicle itself, or a speed measuring system independent of the vehicle, e.g., an acceleration sensor, or by calculations based on the Doppler effect, etc."</p>

Limitation of '781 Patent Claim 23	Automotive Electronics Handbook (Jurgen)	German Patent Application Publication No. 29 26 070 (Volkswagen '070)	U.S. Patent No. 5,357,438 (Davidian)
			<p>E.g., col. 10, lines 17 to 26, "FIG. 7 is a circuit diagram of the microcomputer 4 and the other components of the electrical system. The microprocessor is indicated by block 100, its power supply by block 102, and its watchdog circuit by block 104. <i>It includes a transmitter 106 and a receiver 108 for transmitting and receiving the pulses (e.g., RF, ultrasound, laser, IR, etc.) in the front space sensor 8 and the rear space sensor 10 for measuring the distance of the vehicle from objects in front of, and to the rear, of the vehicle, respectively.</i>"</p> <p>E.g., col. 10, lines 38 to 50, "As indicated earlier, the distance of the vehicle from an object is determined by the front space sensor 8 with respect to objects in front of the vehicle, and by the rear space sensor 10 with respect to objects at the rear of the vehicle. Each of these space sensors may be of known construction, including a transmitter as indicated at 106 in FIG. 7, and a receiver as indicated at 108. <i>Thus, pulses are continuously transmitted by each transmitter, and the echoes from the objects in front of or to the rear of the vehicle are received by the respective receiver. The computer then measures the round-trip time from the pulse transmission to the echo reception in order to determine the distance of the vehicle from the object.</i>"</p>
a plurality of sensors coupled to a vehicle having an engine, said plurality of sensors, which	E.g., page 7.6, "There are several applications for rotational speed sensing. <i>First it is necessary to monitor engine speed.</i> This information is used for transmission control, engine control, cruise control, and possibly for a tachometer. Electronics and electronic sensing in the automobile were brought about by the need for	E.g., page 6 (English translation), "As can be seen when viewing Figure 1 to begin with, output N of the engine has been plotted across engine speed n. a is the curve of the output at full load, b is a line that represents a constant setting of the output control element, i.e., a line that represents a constant <i>throttle valve angle</i> in a carburetor	E.g., col. 4, lines 60 to 66, "Vehicle 2 is further equipped with a <i>speed sensor 12 which may sense the speed of the vehicle in any known manner</i> , for example using the speed measuring system of the vehicle itself, or a speed measuring system independent of the vehicle, e.g., an acceleration sensor, or by calculations based on the Doppler

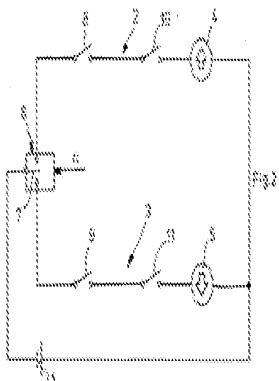

Limitation of '781 Patent Claim 23	Automotive Electronics Handbook (Jurgen)	German Patent Application Publication No. 29 26 070 (Volkswagen '070)	U.S. Patent No. 5,357,438 (Davidian)
<p>collectively monitor operation of said vehicle, including a road speed sensor, and engine speed sensor, a manifold pressure sensor and a throttle position sensor;</p>	<p>higher efficiency engines, better fuel economy, increased power and performance, and lower emissions. Second, <i>wheel speed sensing is required</i> for use in transmissions, cruise control, speedometers, antilock brake systems (ABS), traction control (ASR), variable ratio power steering assist, four-wheel steering, and possibly in inertial navigation and air bag deployment applications.”</p> <p>E.g., page 7.8, “In electronic transmission applications, <i>information from the road and engine speed sensors</i>, as well as torque data and throttle position are required for the MCU to select the optimum gear ratio.”</p> <p>E.g., page 2.5, “Automotive specification and testing guidelines have been developed and published by the Society of Automotive Engineers (SAE) specifically for <i>manifold absolute pressure (MAP) sensors</i>.”</p> <p>E.g., page 2.7, “Manifold absolute pressure (MAP) is used as an input to fuel and ignition control in internal combustion engine control systems. <i>The speed-density system that uses the MAP sensor</i> has been preferred over mass air flow (MAF) control because it's less expensive, but stricter emission standards are causing more manufacturers to use mass air flow for future models.”</p> <p>E.g., page 12.18, “To control the idle speed, the ECU uses inputs from the <i>throttle position sensor</i>, air conditioning, automatic transmission, power steering, charging system, engine RPM,</p>	<p>engine. As a measure thereof, in addition to the <i>throttle valve angle</i> itself, it is also possible to use the <i>induction manifold vacuum</i>. . . . The operating ranges I and II are further delimited by <i>engine speed</i> values <math>n_1</math> or <math>n_2</math>, the first of which usually lies between approximately 20 to 50% of the maximum engine speed, and the second usually lies between approximately 40 and 70% of the maximum engine speed.”</p> <p>E.g., page 8 (English translation), “<i>The engine speed signal is obtained with the aid of known sensor systems</i>, which therefore need not be described in further detail here.”</p> <p>E.g., page 9 (English translation), “It is useful if in addition to this device, a display of the route-specific fuel consumption is provided in a vehicle. Such display devices are known per se; they generally utilize the <i>injection manifold vacuum</i> as a measure of fuel consumption.”</p>	<p>effect, etc.”</p>

Limitation of '781 Patent Claim 23	Automotive Electronics Handbook (Jurgen)	German Patent Application Publication No. 29 26 070 (Volkswagen '070)	U.S. Patent No. 5,357,438 (Davidian)
	<p>and vehicle speed.”</p> <p>E.g., page 12.21, “The electronic injection unit also houses the <i>throttle position sensor</i> and, in some cases, an inlet air temperature sensor which provides operating condition information to the ECU.”</p>		
<p>a processor subsystem, coupled to said radar detector and each one of said plurality of sensors, to receive data therefrom;</p>	<p>E.g., page 12.1, “The electronic engine control system consists of <i>sensing devices which continuously measure the operating conditions of the engine, an electronic control unit (ECU) which evaluates the sensor inputs</i> using data tables and calculations and determines the output to the actuating devices, and actuating devices which are commanded by the ECU to perform an action in response to the sensor inputs.”</p> <p>E.g., page 22.6, “During the entire operating time of the vehicle, <i>the ECUs are constantly supervising the sensors they are connected to.</i>”</p> <p>E.g., page 13.4, “On the functional side, the hardware configuration can be divided into power supply, input signal transfer circuits, output stages, and <i>microcontroller</i>, including peripheral components and monitoring and safety circuits (Fig. 13.1).”</p> <p>E.g., Figure 13.1:</p>	<p>E.g., pages 7 to 8 (English translation), “<i>The two control circuits 2 and 3 are selectively closed by engine-speed dependent change-over switch 6, to which a signal that corresponds to the individual engine speed <math>n</math> is forwarded</i> and which is developed in such a way that at engine speeds that are greater than predefined engine speed <math>n_1</math> (see Figure 1), its shift lever pivots upwardly in Figure 2, but at engine speeds that are smaller than predefined engine speed <math>n_2</math>, it pivots in the downward direction from a neutral center position, which it therefore assumes when engine speed values between <math>n_1</math> and <math>n_2</math> are present.”</p> <p>E.g., Figure 2:</p> 	<p>E.g., col. 8, lines 29 to 43, “<i>FIGS. 6a, 6b, are a block diagram illustrating the microcomputer 4 and its inputs and outputs described earlier which enable it to continuously monitor the operation of the vehicle</i> and to actuate first a Safety alarm, and then a Collision alarm whenever the vehicle may enter a danger-of-collision situation according to the various preset parameters and automatic parameters introduced into the computer.</p> <p><i>The microcomputer 4 as illustrated in FIGS. 6a, 6b is divided into various functional modules, as follows: a calculation module 90, which receives data concerning the various parameters briefly described above and as will be described more particularly below to enable it to make the necessary computations for actuating the Safety alarm and the Collision alarm.</i>”</p> <p>E.g., col. 8, lines 58 to 60, “Thus, module 90 receives inputs from the front space sensor 8, the rear space sensor 10, and the vehicle speed sensor 12.”</p> <p>E.g., Figure 6A:</p>

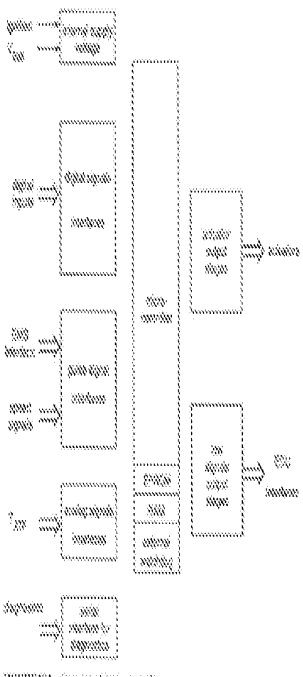
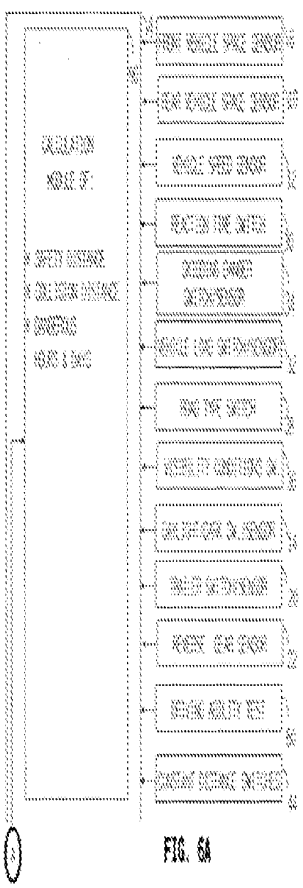
Limitation of '781 Patent Claim 23	Automotive Electronics Handbook (Jurgen)	German Patent Application Publication No. 29 26 070 (Volkswagen '070)	U.S. Patent No. 5,357,438 (Davidian)
	 <p>FIGURE 531</p> <p>E.g., page 14.3, “The speed sensor is one of the most critical parts in the system, because the <i>microcontroller calculates the vehicle speed from the speed sensor’s signal</i> to within 1/32 m/h.”</p>		 <p>FIG. 6A</p>
<p>a memory subsystem, coupled to said processor subsystem, said memory subsystem storing therein a first vehicle speed/stopping distance table, a</p>	<p>E.g., page 13.5, “The calculators inside the control units are usually microcontrollers. . . . <i>The memory devices for program and data are usually EPROMS.</i> Their storage capacity is, in present applications, up to 64 Kbytes. Future applications will necessitate storage sizes up to 128 Kbytes. The failure storages for diagnostics and the storage for adaptive data are in conventional applications, battery voltage-supplied RAMs. These are increasingly being replaced by EEPROMs.”</p>	<p>E.g., page 6 (English translation), “As can be seen when viewing Figure 1 to begin with, <i>output N of the engine has been plotted across engine speed n.</i>”</p> <p>E.g., page 6 (English translation), “<i>The numerical values of the limits of the two operating ranges I and II are of course dependent on the individual situation.</i> In general, it can be said that these two operating ranges lie in such a way that by shift operations,</p>	<p>E.g., col. 9, lines 20 to 27, “<i>Computer module 90 also includes information about the vehicle braking distances as a function of speed. This is preferably in the form of a look-up table, for example, provided by the manufacturer for predetermined defined conditions concerning road type, skidding danger, vehicle load and tires pressure, and is stored in a ROM (read-only memory) of the microcomputer so that it can be changed periodically if necessary.</i>”</p>

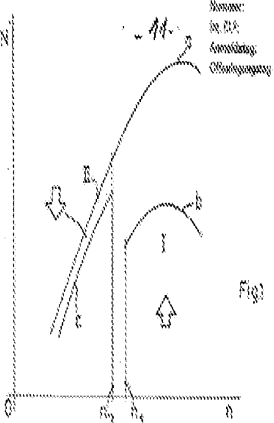
Limitation of '781 Patent Claim 23	Automotive Electronics Handbook (Jurgen)	German Patent Application Publication No. 29 26 070 (Volkswagen '070)	U.S. Patent No. 5,357,438 (Davidian)
<p>manifold pressure set point, an RPM set point, and present and prior levels for each one of said plurality of sensors;</p>	<p>E.g., page 12.9, "A subsystem of the fuel control system is lambda closed-loop control. . . .</p> <p>[T]he engine control unit uses an anticipatory control strategy that uses engine load and RPM to determine the approximate fuel requirement. <i>The engine load information is provided by the manifold pressure sensor for speed density systems and by the air meter for air flow and air mass measurement systems and by the throttle valve position sensor. The engine control unit contains data tables for combinations of load and RPM.</i> This allows for rapid response to changes in operating conditions. The lambda sensor still provides the feedback correction for each load/RPM point. . . .</p> <p>[T]he electronic control unit has a feature for adapting changes in the fuel required for the load/RPM points. <i>At each load/RPM point, the lambda sensor continuously provides information that allows the system to adjust the fuel to the commanded A/F ratio. The corrected information is stored in RAM (random access memory) so that the next time the engine reaches that operating point (load/RPM), the anticipatory value will require less correction. These values remain stored in the electronic control unit even after the engine is shut off.</i> Only if power to the electronic control unit is disrupted (i.e., due to a dead battery), will the correction be lost. In that case, the electronic control unit will revert back to the original production values that are written in ROM (read-only memory)."</p>	<p>it is possible to achieve operating points in the output/engine speed diagram that are more favorable in terms of fuel consumption."</p> <p>E.g., page 8 (English translation), "<i>Furthermore, to define the two operating ranges I and II, load-dependent switches 8 and 9 are provided in control circuits 2 and 3 in Figure 2, the first of which is closed only below the line denoted by b in Figure 1, and switch 9 is closed only above the line denoted by c in Figure 1.</i>"</p> <p>E.g., Figure 1:</p> 	<p>E.g., col. 12, line 59 to col 13, line 22, "The system then makes the computations illustrated (as an example) in block 162 to determine the stopping distance SD, which is equal to the reaction distance plus the braking distance multiplied by a stopping factor ST and a safety factor SF. <i>In the illustrated example, the stopping distance is the sum of the reaction distance and the braking distance. The reaction distance is the product of the reaction time, visibility condition, daylight condition, reaction factor and speed; and the braking distance is the product of the braking distance (as supplied by the manufacturer), road type, skidding danger, vehicle load and braking factor.</i> The stopping distance (SD) includes further safety factors, and determines when the safety alarm will be actuated to first alert the driver of an approaching collision danger.</p> <p><i>A determination is also made of the collision distance CD which is equal to the stopping distance SD divided by the collision safety factor CSF, e.g., 1.25 in the example illustrated above, such that should the distance between the vehicle and the object come within the collision distance CD, the collision alarm is then actuated.</i></p> <p>The foregoing calculations of stopping distance SD and collision distance CD with respect to objects at the front of the vehicle are also made with respect to objects at the rear of the vehicle, these calculations being RSD and RCD, respectively, also shown in block 162.</p> <p>Whenever the distance between the vehicle and an object to the front of the vehicle or to the rear of the vehicle comes within the stopping distance SD and</p>

Limitation of '781 Patent Claim 23	Automotive Electronics Handbook (Jurgen)	German Patent Application Publication No. 29 26 070 (Volkswagen '070)	U.S. Patent No. 5,357,438 (Davidian)
	<p>E.g., page 14.2, "Other safety-related items include <i>program code to detect abnormal operating conditions and preserving into memory the data points associated with the abnormal condition for later diagnostics.</i> Abnormal conditions, for example, could be an intermittent vehicle speed sensor, or erratic driver switch signals."</p> <p>E.g., pages 22.2 to 22.3, "The most important test points of control units and sensors are tied to a diagnostic connector which is plugged into the measuring instrument with a corresponding adapter for the respective vehicle. . . . <i>Modern electronics in vehicles support diagnosis by comparing the registered actual value with the internally stored nominal values</i> with the help of control units and their self-diagnosis, thus detecting faults."</p>		<p>the collision distance CD, the system operates according to the deceleration alarm module 93, as indicated by block 164."</p>
<p>a fuel overinjection notification circuit coupled to said processor subsystem, said fuel overinjection notification circuit issuing a notification that excessive fuel is being supplied to said engine of said vehicle;</p>	<p>E.g., page 12.22, "During an acceleration transition, the ECU adds a correction factor (an increase) to the commanded injector pulse width. The sudden increase in air results in a lean mixture which must be corrected swiftly to obtain good transitional response. <i>During a deceleration transition, the fuel can be shut off by simply not providing a pulse width signal to the injector to minimize exhaust emissions and fuel consumption.</i>"</p> <p>E.g., page 12.4, "During coasting and braking, fuel consumption can be further reduced by shutting off the fuel until the engine speed decreases to slightly higher than the set idle speed. <i>The ECU determines when fuel shutoff can occur by evaluating the throttle position,</i></p>	<p>E.g., page 9 (English translation), "It is useful if in addition to this device, <i>a display of the route-specific fuel consumption is provided in a vehicle.</i> Such display devices are known per se; they generally utilize the injection manifold vacuum as a measure of fuel consumption."</p>	

Limitation of '781 Patent Claim 23	Automotive Electronics Handbook (Jurgen)	German Patent Application Publication No. 29 26 070 (Volkswagen '070)	U.S. Patent No. 5,357,438 (Davidian)
	<p><i>engine RPM, and vehicle speed.”</i></p> <p>E.g., page 12.14, “Using the inputs of engine RPM and vehicle speed to the electronic control unit, thresholds can be established for limiting these variables with fuel cutoff. <i>When the maximum speed is achieved, the fuel injectors are shut off.</i> When the speed decreases below the threshold, fuel injection resumes.”</p> <p>E.g., page 12.17, “<i>During transition to fuel cutoff, the ignition timing is retarded from its current setting to reduce engine torque and to assist in engine braking. The fuel is then shut off.</i> During the transition, the throttle bypass valve or the main throttle valve may remain open for a short period to allow fresh air to oxidize the remaining unburned HC and CO to further reduce exhaust emissions. During development of the fuel cutoff strategy, the advantage of reduced emission effects and catalyst temperature control must be balanced against driveability requirements. The use of fuel cutoff may change the perceived amount of engine braking felt by the driver. In addition, care must be taken to avoid a ‘bump’ feel when entering the fuel cutoff mode, due to the change in torque.”</p>		
<p>an upshift notification circuit coupled to said processor subsystem, said upshift notification circuit issuing a notification that</p>	<p>E.g., page 13.7 to 13.9, “<i>The basic functions of the transmission control are the shift point control, the lockup control, engine torque control during shifting, related safety functions, and diagnostic functions for vehicle service.</i>”</p> <p>E.g., page 13.9, “The basic shift point control uses shift maps, which are defined in data in the unit memory. These shift maps are selectable over</p>	<p>E.g., pages 6 to 7 (English translation), “Looking initially at operating range I remote from full load, <i>the desired output at a lower specific fuel consumption is able to be achieved after upshifting into the next higher gear,</i> at an operating point that lies to the left of operating range I in the diagram of Figure 1. <i>Accordingly, the device of the present invention generates a signal that asks the operator, i.e., normally the</i></p>	

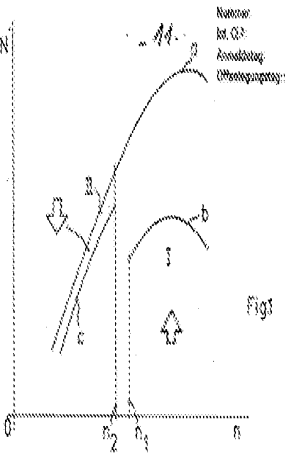
Limitation of '781 Patent Claim 23	Automotive Electronics Handbook (Jurgen)	German Patent Application Publication No. 29 26 070 (Volkswagen '070)	U.S. Patent No. 5,357,438 (Davidian)
<p>said engine of said vehicle is being operated at an excessive engine speed;</p>	<p>a wide range. <i>The shift point limitations are made, on the one hand, by the highest admissible engine speed for each application and, on the other hand, by the lowest engine speed that is practical for driving comfort and noise emission. The inputs of the shift point determination are the throttle position, the accelerator pedal position, and the vehicle speed (determined by the transmission output speed).</i></p> <p>E.g., page 13.14, "In addition to these functions, <i>different shift maps can be implemented into the data field of the TCU [Transmission Control Unit].</i> For example, it is possible to have one shift map for low fuel consumption, which has shift points in the range of the best efficiency of the engine, and additionally to have another map for power operation, where the shift points are placed at points of highest engine output power."</p>	<p><i>driver, to shift to a higher gear, which is indicated in Figure 1 by the upward pointing arrow within operating range I."</i></p> <p>E.g., pages 7 to 8 (English translation), "The two control circuits 2 and 3 are selectively closed by engine-speed dependent change-over switch 6, to which a signal that corresponds to the individual engine speed <math>n</math> is forwarded and which is developed in such a way that <i>at engine speeds that are greater than predefined engine speed <math>n_1</math> (see Figure 1), its shift lever pivots upwardly in Figure 2, but at engine speeds that are smaller than predefined engine speed <math>n_2</math>, it pivots in the downward direction from a neutral center position, which it therefore assumes when engine speed values between <math>n_1</math> and <math>n_2</math> are present.</i>"</p> <p>E.g., Figure 1:</p>  <p>E.g., Figure 2:</p>	

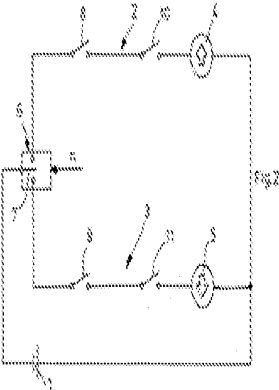
Limitation of '781 Patent Claim 23	Automotive Electronics Handbook (Jurgen)	German Patent Application Publication No. 29 26 070 (Volkswagen '070)	U.S. Patent No. 5,357,438 (Davidian)
			
<p>said processor subsystem determining, based upon data received from said plurality of sensors, when to activate said fuel overinjection circuit and when to activate said upshift notification circuit;</p>	<p>E.g., page 12.4, “During coasting and braking, fuel consumption can be further reduced by shutting off the fuel until the engine speed decreases to slightly higher than the set idle speed. <i>The ECU determines when fuel shutoff can occur by evaluating the throttle position, engine RPM, and vehicle speed.</i>”</p> <p>E.g., page 12.14, “Using the inputs of engine RPM and vehicle speed to the electronic control unit, thresholds can be established for limiting these variables with fuel cutoff. <i>When the maximum speed is achieved, the fuel injectors are shut off.</i> When the speed decreases below the threshold, fuel injection resumes.”</p> <p>E.g., page 13.7 to 13.9, “<i>The basic functions of the transmission control are the shift point control, the lockup control, engine torque control during shifting, related safety functions, and diagnostic functions for vehicle service.</i>”</p> <p>E.g., page 13.9, “The basic shift point control uses shift maps, which are defined in data in the</p>	<p>E.g., pages 6 to 7 (English translation), “Looking initially at operating range I remote from full load, the desired output at a lower specific fuel consumption is able to be achieved after upshifting into the next higher gear, at an operating point that lies to the left of operating range I in the diagram of Figure 1. <i>Accordingly, the device of the present invention generates a signal that asks the operator, i.e., normally the driver, to shift to a higher gear, which is indicated in Figure 1 by the upward pointing arrow within operating range I.</i>”</p> <p>E.g., pages 7 to 8 (English translation), “The two control circuits 2 and 3 are selectively closed by engine-speed dependent change-over switch 6, to which a signal that corresponds to the individual engine speed <math>n</math> is forwarded and which is developed in such a way that <i>at engine speeds that are greater than predefined engine speed <math>n_1</math> (see Figure 1), its shift lever pivots upwardly in Figure 2, but at engine speeds that are smaller than predefined engine speed <math>n_2</math>, it pivots in the downward direction from a neutral center</i></p>	



Limitation of '781 Patent Claim 23	Automotive Electronics Handbook (Jurgen)	German Patent Application Publication No. 29 26 070 (Volkswagen '070)	U.S. Patent No. 5,357,438 (Davidian)
	<p>unit memory. These shift maps are selectable over a wide range. <i>The shift point limitations are made</i>, on the one hand, by the highest admissible engine speed for each application and, on the other hand, <i>by the lowest engine speed that is practical for driving comfort and noise emission. The inputs of the shift point determination are the throttle position, the accelerator pedal position, and the vehicle speed</i> (determined by the transmission output speed)."</p>	<p><i>position</i>, which it therefore assumes when engine speed values between <math>n_1</math> and <math>n_2</math> are present."</p> <p>E.g., page 7 (English translation), "<i>When the operating point lies in operating range II, the device according to the present invention generates a signal that asks the driver to downshift, which is indicated by the downward pointing arrow at operating range II in Figure 1.</i>"</p> <p>E.g., page 9 (English translation), "It is useful if in addition to this device, <i>a display of the route-specific fuel consumption</i> is provided in a vehicle. Such display devices are known per se; they generally utilize the <i>injection manifold vacuum</i> as a measure of fuel consumption."</p>	
<p>a vehicle proximity alarm circuit coupled to said processor subsystem, said vehicle proximity alarm circuit issuing an alarm that said vehicle is too close to said object;</p>			<p>E.g., col. 3, lines 59 to 66, "The anti-collision system illustrated in FIGS. 1-14 is particularly useful for motor vehicles (passengers cars, buses, trucks) in order to <i>actuate an alarm when the vehicle is travelling at a distance behind another vehicle or in front of another</i>, which is equal to or less than a danger-of-collision distance computed by a computer such that if the front vehicle stops suddenly there is a danger of a rear-end collision."</p> <p>E.g., col. 4, lines 14 to 16, "In the system described below, <i>there are two alarms: a Collision alarm, which is actuated when the vehicle is determined to be within the danger-of-collision distance; and a Safety alarm, which is actuated before the Collision alarm, at a distance greater than the danger-of-collision distance by a predetermined safety factor</i>, e.g., 1.25."</p>

Limitation of '781 Patent Claim 23	Automotive Electronics Handbook (Jurgen)	German Patent Application Publication No. 29 26 070 (Volkswagen '070)	U.S. Patent No. 5,357,438 (Davidian)
			<p>E.g., col. 6, lines 25 to 29, "Control panel 6 further includes a front distance display 46, in which are displayed the distance to the front vehicle (in region 46a), in which direction (by arrow 46b), and <i>whether or not there is a collision danger (region 46c).</i>"</p> <p>E.g., col. 6, lines 41 to 46, "Control panel 6 further includes a speaker 54 for producing an <i>audio alarm in the event of a collision danger, in addition to the visually-indicated alarms</i> of sections 46c and 48c of the displays 46 and 48."</p> <p>E.g., col. 8, lines 37 to 48, "The <i>microcomputer 4</i> as illustrated in FIGS. 6a, 6b is divided into various functional modules, as follows:  <i>... a deceleration alarm module 93, which controls the Safety alarm and Collision alarm on the control panel, ...</i>"</p> <p>E.g., Figs. 3 and 6B (ref. no. 46C)</p>
<p>said processor subsystem determining, based upon data received from said radar detector, said at least one sensor and said memory subsystem, when to activate said vehicle proximity alarm circuit.</p>			<p>E.g., col. 8, lines 37 to 43, "The <i>microcomputer 4</i> as illustrated in FIGS. 6a, 6b is divided into various functional modules, as follows: a calculation module 90, <i>which receives data concerning the various parameters briefly described above</i> and as will be described more particularly below <i>to enable it to make the necessary computations for actuating the Safety alarm and the Collision alarm; ...</i>"</p> <p>E.g., col. 12, line 59 to col 13, line 11, "The system then makes the computations illustrated (as an example) in block 162 to determine the stopping distance SD, which is equal to the reaction distance plus the braking distance multiplied by a stopping</p>

Limitation of '781 Patent Claim 23	Automotive Electronics Handbook (Jurgen)	German Patent Application Publication No. 29 26 070 (Volkswagen '070)	U.S. Patent No. 5,357,438 (Davidian)
			<p>factor ST and a safety factor SF. In the illustrated example, the stopping distance is the sum of the reaction distance and the braking distance. The reaction distance is the product of the reaction time, visibility condition, daylight condition, reaction factor and speed; and the braking distance is the product of the braking distance (as supplied by the manufacturer), road type, skidding danger, vehicle load and braking factor. <i>The stopping distance (SD) includes further safety factors, and determines when the safety alarm will be actuated to first alert the driver of an approaching collision danger.</i></p> <p><i>A determination is also made of the collision distance CD which is equal to the stopping distance SD divided by the collision safety factor CSF, e.g., 1.25 in the example illustrated above, such that should the distance between the vehicle and the object come within the collision distance CD, the collision alarm is then actuated.</i></p> <p>E.g., col. 13, lines 17 to 22, <i>"Whenever the distance between the vehicle and an object to the front of the vehicle or to the rear of the vehicle comes within the stopping distance SD and the collision distance CD, the system operates according to the deceleration alarm module 93, as indicated by block 164."</i></p>

Limitation of '781 Patent Claim 26	Automotive Electronics Handbook (Jurgen)	German Patent Application Publication No. 29 26 070 (Volkswagen '070)	U.S. Patent No. 5,357,438 (Davidian)
<p>26. Apparatus for optimizing operation of a vehicle, comprising:</p>	<p>E.g., page 12.1, "The electronic engine control system consists of sensing devices which continuously measure the operating conditions of the engine, <i>an electronic control unit (ECU) which evaluates the sensor inputs using data tables and calculations and determines the output to the actuating devices</i>, and actuating devices which are commanded by the ECU to perform an action in response to the sensor inputs.</p> <p>The motive for using an electronic engine control system is to provide the needed accuracy and adaptability in order to minimize exhaust emissions and fuel consumption, <i>provide optimal driveability for all operating conditions</i>, minimize evaporative emissions, and provide system diagnosis when malfunctions occur."</p>	<p>E.g., page 5 (English translation), "The present invention is based on the objective of providing <i>a device that assists the operator of the internal combustion engine equipped with a conventional transmission</i>, i.e., the driver of a motor vehicle, for example, in setting an operating point of the engine that is advantageous in terms of consumption, by way of gear shift operations."</p>	<p>E.g., col. 1, lines 1 to 2, "The present invention relates to <i>an anti-collision system for vehicles.</i>"</p>
<p>a radar detector, said radar detector determining a distance separating a vehicle having an engine and an object in front of said vehicle;</p>	<p>E.g., page 7.23, "Ultrasonics, infrared, laser, and <i>microwaves (radar) can be used in the detection of objects behind vehicles and in the blind areas.</i>"</p>		<p>E.g., col. 4, lines 52 to 66, "<i>Vehicle 2 further includes a front space sensor 8 for sensing the space in front of the vehicle, such as the presence of another vehicle, a corresponding rear space sensor 10, and a pair of side sensors 11.</i> All the space sensors are in the form of pulse (e.g., ultrasonic) transmitters and receivers, for determining the distance of the vehicle from an object, e.g., another vehicle, at front or rear. Space sensors may also be provided at the sides of the vehicle. Vehicle 2 is further equipped with a speed sensor 12 which may sense the speed of the vehicle in any known manner, for example using the speed measuring system of the vehicle itself, or a speed measuring system independent of the vehicle, e.g., an acceleration sensor, or by</p>

Limitation of '781 Patent Claim 26	Automotive Electronics Handbook (Jurgen)	German Patent Application Publication No. 29 26 070 (Volkswagen '070)	U.S. Patent No. 5,357,438 (Davidian)
			<p>calculations based on the Doppler effect, etc.”</p> <p>E.g., col. 10, lines 17 to 26, “FIG. 7 is a circuit diagram of the microcomputer 4 and the other components of the electrical system. The microprocessor is indicated by block 100, its power supply by block 102, and its watchdog circuit by block 104. <b><i>It includes a transmitter 106 and a receiver 108 for transmitting and receiving the pulses (e.g., RF, ultrasound, laser, IR, etc.) in the front space sensor 8 and the rear space sensor 10 for measuring the distance of the vehicle from objects in front of, and to the rear, of the vehicle, respectively.</i></b>”</p> <p>E.g., col. 10, lines 38 to 50, “As indicated earlier, the distance of the vehicle from an object is determined by the front space sensor 8 with respect to objects in front of the vehicle, and by the rear space sensor 10 with respect to objects at the rear of the vehicle. Each of these space sensors may be of known construction, including a transmitter as indicated at 106 in FIG. 7, and a receiver as indicated at 108. <b><i>Thus, pulses are continuously transmitted by each transmitter, and the echoes from the objects in front of or to the rear of the vehicle are received by the respective receiver. The computer then measures the round-trip time from the pulse transmission to the echo reception in order to determine the distance of the vehicle from the object.</i></b>”</p>
a plurality of sensors coupled to a vehicle having	E.g., page 7.6, “There are several applications for rotational speed sensing. <b><i>First it is necessary to monitor engine speed.</i></b> This information is used for	E.g., page 6 (English translation), “As can be seen when viewing Figure 1 to begin with, output N of the engine has been plotted across engine speed n. a is the curve of the output at full load, b is a line that represents a constant	E.g., col. 4, lines 60 to 66, “Vehicle 2 is further equipped with <b><i>a speed sensor 12 which may sense the speed of the vehicle in any known manner,</i></b> for example using the speed measuring

Limitation of '781 Patent Claim 26	Automotive Electronics Handbook (Jurgen)	German Patent Application Publication No. 29 26 070 (Volkswagen '070)	U.S. Patent No. 5,357,438 (Davidian)
<p>an engine, said plurality of sensors, which collectively monitor operation of said vehicle, including a road speed sensor, and engine speed sensor, a manifold pressure sensor and a throttle position sensor;</p>	<p>transmission control, engine control, cruise control, and possibly for a tachometer. Electronics and electronic sensing in the automobile were brought about by the need for higher efficiency engines, better fuel economy, increased power and performance, and lower emissions. Second, <b>wheel speed sensing is required</b> for use in transmissions, cruise control, speedometers, antilock brake systems (ABS), traction control (ASR), variable ratio power steering assist, four-wheel steering, and possibly in inertial navigation and air bag deployment applications.”</p> <p>E.g., page 7.8, “In electronic transmission applications, <b>information from the road and engine speed sensors</b>, as well as torque data and throttle position are required for the MCU to select the optimum gear ratio.”</p> <p>E.g., page 2.5, “Automotive specification and testing guidelines have been developed and published by the Society of Automotive Engineers (SAE) specifically for <b>manifold absolute pressure (MAP) sensors</b>.”</p> <p>E.g., page 2.7, “Manifold absolute pressure (MAP) is used as an input to fuel and ignition control in internal combustion engine control systems. <b>The speed-density system that uses the MAP sensor</b> has been preferred over mass air flow (MAF) control because it's less expensive, but stricter emission standards are causing more manufacturers to use mass air flow for future</p>	<p>setting of the output control element, i.e., a line that represents a constant <b>throttle valve angle</b> in a carburetor engine. As a measure thereof, in addition to the <b>throttle valve angle</b> itself, it is also possible to use the <b>induction manifold vacuum</b>. . . . The operating ranges I and II are further delimited by <b>engine speed</b> values <math>n_1</math> or <math>n_2</math>, the first of which usually lies between approximately 20 to 50% of the maximum engine speed, and the second usually lies between approximately 40 and 70% of the maximum engine speed.”</p> <p>E.g., page 8 (English translation), “<b>The engine speed signal is obtained with the aid of known sensor systems</b>, which therefore need not be described in further detail here.”</p> <p>E.g., page 9 (English translation), “It is useful if in addition to this device, a display of the route-specific fuel consumption is provided in a vehicle. Such display devices are known per se; they generally utilize the <b>injection manifold vacuum</b> as a measure of fuel consumption.”</p>	<p>system of the vehicle itself, or a speed measuring system independent of the vehicle, e.g., an acceleration sensor, or by calculations based on the Doppler effect, etc.”</p>

Limitation of '781 Patent Claim 26	Automotive Electronics Handbook (Jurgen)	German Patent Application Publication No. 29 26 070 (Volkswagen '070)	U.S. Patent No. 5,357,438 (Davidian)
	<p>models.”</p> <p>E.g., page 12.18, “To control the idle speed, the ECU uses inputs from the <i>throttle position sensor</i>, air conditioning, automatic transmission, power steering, charging system, engine RPM, and vehicle speed.”</p> <p>E.g., page 12.21, “The electronic injection unit also houses the <i>throttle position sensor</i> and, in some cases, an inlet air temperature sensor which provides operating condition information to the ECU.”</p>		
<p>a processor subsystem, coupled to said radar detector and each one of said plurality of sensors, to receive data therefrom;</p>	<p>E.g., page 12.1, “The electronic engine control system consists of <i>sensing devices which continuously measure the operating conditions of the engine, an electronic control unit (ECU) which evaluates the sensor inputs</i> using data tables and calculations and determines the output to the actuating devices, and actuating devices which are commanded by the ECU to perform an action in response to the sensor inputs.”</p> <p>E.g., page 22.6, “During the entire operating time of the vehicle, <i>the ECUs are constantly supervising the sensors they are connected to.</i>”</p> <p>E.g., page 13.4, “On the functional side, the hardware configuration can be divided into power supply, input signal transfer circuits, output stages, and <i>microcontroller</i>, including peripheral components and monitoring and safety circuits (Fig. 13.1).”</p>	<p>E.g., pages 7 to 8 (English translation), “<i>The two control circuits 2 and 3 are selectively closed by engine-speed dependent change-over switch 6, to which a signal that corresponds to the individual engine speed <math>n</math> is forwarded</i> and which is developed in such a way that at engine speeds that are greater than predefined engine speed <math>n_1</math> (see Figure 1), its shift lever pivots upwardly in Figure 2, but at engine speeds that are smaller than predefined engine speed <math>n_2</math>, it pivots in the downward direction from a neutral center position, which it therefore assumes when engine speed values between <math>n_1</math> and <math>n_2</math> are present.”</p> <p>E.g., Figure 2:</p>	<p>E.g., col. 8, lines 29 to 43, “<i>FIGS. 6a, 6b, are a block diagram illustrating the microcomputer 4 and its inputs and outputs described earlier which enable it to continuously monitor the operation of the vehicle</i> and to actuate first a Safety alarm, and then a Collision alarm whenever the vehicle may enter a danger-of-collision situation according to the various preset parameters and automatic parameters introduced into the computer.</p> <p><i>The microcomputer 4 as illustrated in FIGS. 6a, 6b is divided into various functional modules, as follows: a calculation module 90, which receives data concerning the various parameters briefly described above</i> and as will be described more particularly below to enable it to make the necessary computations for actuating the Safety alarm and the Collision alarm.”</p> <p>E.g., col. 8, lines 58 to 60, “Thus, module 90 receives inputs from the front space sensor 8, the rear space sensor 10, and the vehicle speed</p>

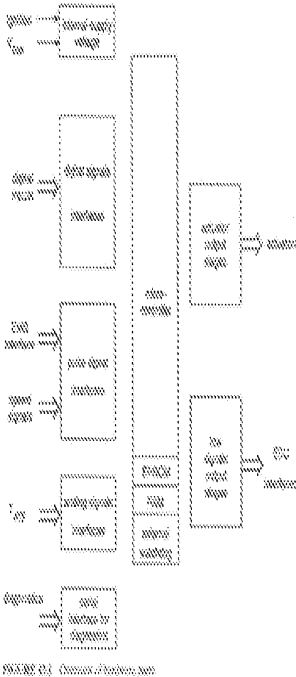
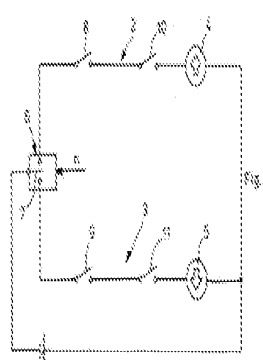
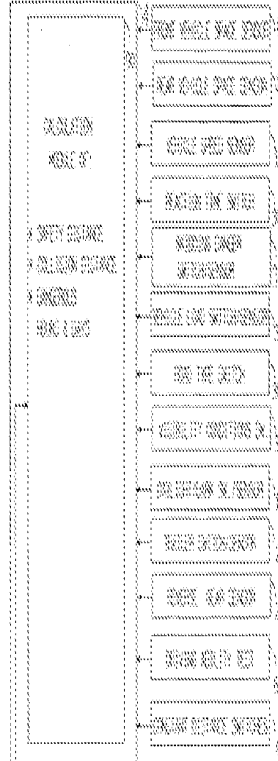
Limitation of '781 Patent Claim 26	Automotive Electronics Handbook (Jurgen)	German Patent Application Publication No. 29 26 070 (Volkswagen '070)	U.S. Patent No. 5,357,438 (Davidian)
	<p>E.g., Figure 13.1:</p>  <p>E.g., page 14.3, "The speed sensor is one of the most critical parts in the system, because the <i>microcontroller calculates the vehicle speed from the speed sensor's signal</i> to within 1/32 m/h."</p>		<p>sensor 12."</p> <p>E.g., Figure 6A:</p>  <p>FIG. 6A</p>
<p>a memory subsystem, coupled to said processor subsystem, said memory subsystem storing therein</p>	<p>E.g., page 13.5, "The calculators inside the control units are usually microcontrollers. . . . <i>The memory devices for program and data are usually EPROMS.</i> Their storage capacity is, in present applications, up to 64 Kbytes. Future applications will necessitate storage sizes up to 128 Kbytes. The failure storages for</p>	<p>E.g., page 6 (English translation), "As can be seen when viewing Figure 1 to begin with, <i>output N of the engine has been plotted across engine speed n.</i>"</p> <p>E.g., page 6 (English translation), "<i>The numerical values of the limits of the two operating ranges I and II are of course dependent on the individual situation.</i> In general, it can be said that these two operating ranges lie in such a way</p>	<p>E.g., col. 9, lines 20 to 27, "<i>Computer module 90 also includes information about the vehicle braking distances as a function of speed. This is preferably in the form of a look-up table, for example, provided by the manufacturer for predetermined defined conditions concerning road type, skidding danger, vehicle load and tires pressure, and is stored in a ROM (read-only</i></p>

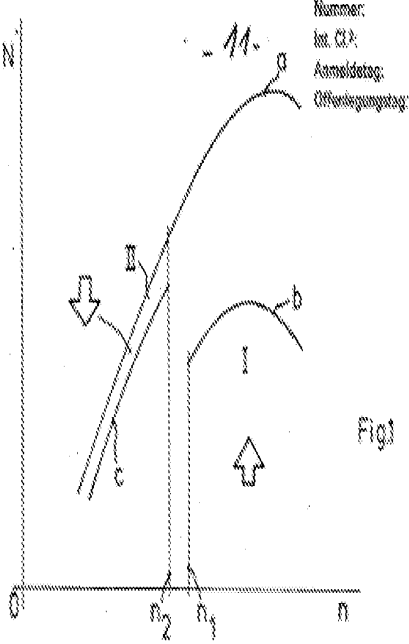

Limitation of '781 Patent Claim 26	Automotive Electronics Handbook (Jurgen)	German Patent Application Publication No. 29 26 070 (Volkswagen '070)	U.S. Patent No. 5,357,438 (Davidian)
<p>a first vehicle speed/stopping distance table, a manifold pressure set point, RPM set point, and present and prior levels for each one of said plurality of sensors;</p>	<p>diagnostics and the storage for adaptive data are in conventional applications, battery voltage-supplied RAMs. These are increasingly being replaced by EEPROMs.”</p> <p>E.g., page 12.9, “A subsystem of the fuel control system is lambda closed-loop control. . . .</p> <p>[T]he engine control unit uses an anticipatory control strategy that uses engine load and RPM to determine the approximate fuel requirement. <i>The engine load information is provided by the manifold pressure sensor for speed density systems and by the air meter for air flow and air mass measurement systems and by the throttle valve position sensor. The engine control unit contains data tables for combinations of load and RPM.</i> This allows for rapid response to changes in operating conditions. The lambda sensor still provides the feedback correction for each load/RPM point. . . .</p> <p>[T]he electronic control unit has a feature for adapting changes in the fuel required for the load/RPM points. <i>At each load/RPM point, the lambda sensor continuously provides information that allows the system to adjust the fuel to the commanded A/F ratio. The corrected information is stored in RAM (random access memory) so that the next time the engine reaches that operating point (load/RPM), the anticipatory value will require less correction. These values remain stored in the electronic control unit</i></p>	<p>that by shift operations, it is possible to achieve operating points in the output/engine speed diagram that are more favorable in terms of fuel consumption.”</p> <p>E.g., page 8 (English translation), “<i>Furthermore, to define the two operating ranges I and II, load-dependent switches 8 and 9 are provided in control circuits 2 and 3 in Figure 2, the first of which is closed only below the line denoted by b in Figure 1, and switch 9 is closed only above the line denoted by c in Figure 1.</i>”</p> <p>E.g., Figure 1:</p>	<p><i>memory) of the microcomputer so that it can be changed periodically if necessary.”</i></p> <p>E.g., col. 12, line 59 to col 13, line 22, “The system then makes the computations illustrated (as an example) in block 162 to determine the stopping distance SD, which is equal to the reaction distance plus the braking distance multiplied by a stopping factor ST and a safety factor SF. <i>In the illustrated example, the stopping distance is the sum of the reaction distance and the braking distance. The reaction distance is the product of the reaction time, visibility condition, daylight condition, reaction factor and speed; and the braking distance is the product of the braking distance (as supplied by the manufacturer), road type, skidding danger, vehicle load and braking factor.</i> The stopping distance (SD) includes further safety factors, and determines when the safety alarm will be actuated to first alert the driver of an approaching collision danger.</p> <p><i>A determination is also made of the collision distance CD which is equal to the stopping distance SD divided by the collision safety factor CSF, e.g., 1.25 in the example illustrated above, such that should the distance between the vehicle and the object come within the collision distance CD, the collision alarm is then actuated.</i></p> <p>The foregoing calculations of stopping distance SD and collision distance CD with respect to objects at the front of the vehicle are also made with respect to objects at the rear of the vehicle, these calculations being RSD and RCD,</p>
			

Limitation of '781 Patent Claim 26	Automotive Electronics Handbook (Jurgen)	German Patent Application Publication No. 29 26 070 (Volkswagen '070)	U.S. Patent No. 5,357,438 (Davidian)
	<p><i>even after the engine is shut off.</i> Only if power to the electronic control unit is disrupted (i.e., due to a dead battery), will the correction be lost. In that case, the electronic control unit will revert back to the original production values that are written in ROM (read-only memory).”</p> <p>E.g., page 14.2, “Other safety-related items include <i>program code to detect abnormal operating conditions and preserving into memory the data points associated with the abnormal condition for later diagnostics.</i> Abnormal conditions, for example, could be an intermittent vehicle speed sensor, or erratic driver switch signals.”</p> <p>E.g., pages 22.2 to 22.3, “The most important test points of control units and sensors are tied to a diagnostic connector which is plugged into the measuring instrument with a corresponding adapter for the respective vehicle. . . .”</p> <p><i>Modern electronics in vehicles support diagnosis by comparing the registered actual value with the internally stored nominal values</i> with the help of control units and their self-diagnosis, thus detecting faults.”</p>		<p>respectively, also shown in block 162.</p> <p>Whenever the distance between the vehicle and an object to the front of the vehicle or to the rear of the vehicle comes within the stopping distance SD and the collision distance CD, the system operates according to the deceleration alarm module 93, as indicated by block 164.”</p>
a fuel overinjection notification circuit coupled to said processor subsystem,	E.g., page 12.22, “During an acceleration transition, the ECU adds a correction factor (an increase) to the commanded injector pulse width. The sudden increase in air results in a lean mixture which must be corrected swiftly to obtain good transitional response. <i>During a deceleration transition,</i>	E.g., page 9 (English translation), “It is useful if in addition to this device, <i>a display of the route-specific fuel consumption is provided in a vehicle.</i> Such display devices are known per se; they generally utilize the injection manifold vacuum as a measure of fuel consumption.”	

Limitation of '781 Patent Claim 26	Automotive Electronics Handbook (Jurgen)	German Patent Application Publication No. 29 26 070 (Volkswagen '070)	U.S. Patent No. 5,357,438 (Davidian)
<p>said fuel overinjection notification circuit issuing a notification that excessive fuel is being supplied to said engine of said vehicle;</p>	<p><i>the fuel can be shut off by simply not providing a pulse width signal to the injector to minimize exhaust emissions and fuel consumption.</i></p> <p>E.g., page 12.4, "During coasting and braking, fuel consumption can be further reduced by shutting off the fuel until the engine speed decreases to slightly higher than the set idle speed. <i>The ECU determines when fuel shutoff can occur by evaluating the throttle position, engine RPM, and vehicle speed.</i>"</p> <p>E.g., page 12.14, "Using the inputs of engine RPM and vehicle speed to the electronic control unit, thresholds can be established for limiting these variables with fuel cutoff. <i>When the maximum speed is achieved, the fuel injectors are shut off.</i> When the speed decreases below the threshold, fuel injection resumes."</p> <p>E.g., page 12.17, "<i>During transition to fuel cutoff, the ignition timing is retarded from its current setting to reduce engine torque and to assist in engine braking. The fuel is then shut off.</i> During the transition, the throttle bypass valve or the main throttle valve may remain open for a short period to allow fresh air to oxidize the remaining unburned HC and CO to further reduce exhaust emissions. During development of the fuel cutoff strategy, the advantage of reduced emission effects and catalyst temperature control must be balanced against driveability requirements. The use of fuel</p>		

Limitation of '781 Patent Claim 26	Automotive Electronics Handbook (Jurgen)	German Patent Application Publication No. 29 26 070 (Volkswagen '070)	U.S. Patent No. 5,357,438 (Davidian)
	<p>cutoff may change the perceived amount of engine braking felt by the driver. In addition, care must be taken to avoid a 'bump' feel when entering the fuel cutoff mode, due to the change in torque."</p>		
<p>a downshift notification circuit coupled to said processor subsystem, said downshift notification circuit issuing a notification that said engine of said vehicle is being operated at an insufficient engine speed;</p>	<p>E.g., page 13.7 to 13.9, "<i>The basic functions of the transmission control are the shift point control, the lockup control, engine torque control during shifting, related safety functions, and diagnostic functions for vehicle service.</i>"</p> <p>E.g., page 13.9, "The basic shift point control uses shift maps, which are defined in data in the unit memory. These shift maps are selectable over a wide range. <i>The shift point limitations are made, on the one hand, by the highest admissible engine speed for each application and, on the other hand, by the lowest engine speed that is practical for driving comfort and noise emission. The inputs of the shift point determination are the throttle position, the accelerator pedal position, and the vehicle speed</i> (determined by the transmission output speed)."</p> <p>E.g., page 13.14, "In addition to these functions, <i>different shift maps can be implemented into the data field of the TCU [Transmission Control Unit].</i> For example, it is possible to have one shift map for low fuel consumption, which has shift points in the range of the best efficiency of the engine, and additionally to have another map for power operation, where the shift points are placed at points of highest engine output</p>	<p>E.g., page 7 (English translation), "When the operating point lies in operating range II, the device according to the present invention generates a signal that asks the driver to downshift, which is indicated by the downward pointing arrow at operating range II in Figure 1."</p> <p>E.g., pages 7 to 8 (English translation), "The two control circuits 2 and 3 are selectively closed by engine-speed dependent change-over switch 6, to which a signal that corresponds to the individual engine speed <math>n</math> is forwarded and which is developed in such a way that at engine speeds that are greater than predefined engine speed <math>n_1</math> (see Figure 1), its shift lever pivots upwardly in Figure 2, but at engine speeds that are smaller than predefined engine speed <math>n_2</math>, it pivots in the downward direction from a neutral center position, which it therefore assumes when engine speed values between <math>n_1</math> and <math>n_2</math> are present."</p> <p>E.g., FIG. 1:</p>	

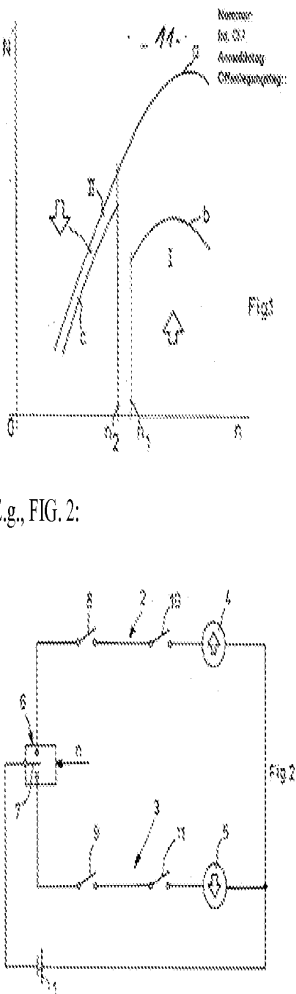
Limitation of '781 Patent Claim 26	Automotive Electronics Handbook (Jurgen)	German Patent Application Publication No. 29 26 070 (Volkswagen '070)	U.S. Patent No. 5,357,438 (Davidian)
	power.”	 <p>E.g., FIG. 2:</p>	
said processor subsystem determining, based upon data received from said plurality of sensors, when to activate said	E.g., page 12.4, “During coasting and braking, fuel consumption can be further reduced by shutting off the fuel until the engine speed decreases to slightly higher than the set idle speed. <i>The ECU determines when fuel shutoff can occur by evaluating the throttle position, engine RPM, and vehicle speed.</i> ”	E.g., pages 6 to 7 (English translation), “Looking initially at operating range I remote from full load, the desired output at a lower specific fuel consumption is able to be achieved after upshifting into the next higher gear, at an operating point that lies to the left of operating range I in the diagram of Figure 1. Accordingly, the device of the present invention generates a signal that asks the operator, i.e., normally the driver, to shift to a higher gear, which is indicated in Figure 1 by the upward pointing arrow within	

Limitation of '781 Patent Claim 26	Automotive Electronics Handbook (Jurgen)	German Patent Application Publication No. 29 26 070 (Volkswagen '070)	U.S. Patent No. 5,357,438 (Davidian)
fuel overinjection circuit and when to activate said downshift notification circuit;	<p>E.g., page 12.14, "Using the inputs of engine RPM and vehicle speed to the electronic control unit, thresholds can be established for limiting these variables with fuel cutoff. <i>When the maximum speed is achieved, the fuel injectors are shut off.</i> When the speed decreases below the threshold, fuel injection resumes."</p> <p>E.g., pages 13.7 to 13.9, "<i>The basic functions of the transmission control are the shift point control, the lockup control, engine torque control during shifting, related safety functions, and diagnostic functions for vehicle service.</i>"</p> <p>E.g., page 13.9, "The basic shift point control uses shift maps, which are defined in data in the unit memory. These shift maps are selectable over a wide range. <i>The shift point limitations are made, on the one hand, by the highest admissible engine speed for each application and, on the other hand, by the lowest engine speed that is practical for driving comfort and noise emission. The inputs of the shift point determination are the throttle position, the accelerator pedal position, and the vehicle speed (determined by the transmission output speed).</i>"</p>	<p><i>operating range I.</i>"</p> <p>E.g., pages 7 to 8 (English translation), "The two control circuits 2 and 3 are selectively closed by engine-speed dependent change-over switch 6, to which a signal that corresponds to the individual engine speed <math>n</math> is forwarded and which is developed in such a way that <i>at engine speeds that are greater than predefined engine speed <math>n_1</math> (see Figure 1), its shift lever pivots upwardly in Figure 2, but at engine speeds that are smaller than predefined engine speed <math>n_2</math>, it pivots in the downward direction from a neutral center position</i>, which it therefore assumes when engine speed values between <math>n_1</math> and <math>n_2</math> are present."</p> <p>E.g., page 7 (English translation), "<i>When the operating point lies in operating range II, the device according to the present invention generates a signal that asks the driver to downshift, which is indicated by the downward pointing arrow at operating range II in Figure 1.</i>"</p> <p>E.g., page 9 (English translation), "It is useful if in addition to this device, <i>a display of the route-specific fuel consumption is provided in a vehicle.</i> Such display devices are known per se; they generally utilize the injection manifold vacuum as a measure of fuel consumption."</p>	
a vehicle proximity alarm circuit coupled to said processor subsystem, said vehicle	E.g., page 7.6, "[W]heel speed sensing is required for use in transmissions, cruise control, speedometers, antilock brake systems (ABS), traction control (ASR), variable ratio power steering assist, four-wheel steering, and possibly in inertial navigation and air bag deployment		E.g., col. 3, lines 59 to 66, "The anti-collision system illustrated in FIGS. 1-14 is particularly useful for motor vehicles (passengers cars, buses, trucks) in order to <i>actuate an alarm when the vehicle is travelling at a distance behind another vehicle or in front of another</i> , which is equal to or less than a danger-of-collision

Limitation of '781 Patent Claim 26	Automotive Electronics Handbook (Jurgen)	German Patent Application Publication No. 29 26 070 (Volkswagen '070)	U.S. Patent No. 5,357,438 (Davidian)
<p>proximity alarm circuit issuing an alarm that said vehicle is too close to said object;</p>	<p>applications. Linear speed sensing can be used to measure the ground speed. This measurement also has the possibly of use in ABS, ASR, and inertial navigation. <i>Similar types of sensors can be used in crash avoidance, proximity, and obstacle detection applications.</i></p> <p>E.g., page 7.23, "Ultrasonics, infrared, laser, and microwaves (radar) can be used in the detection of objects behind vehicles and in the blind areas."</p>		<p>distance computed by a computer such that if the front vehicle stops suddenly there is a danger of a rear-end collision."</p> <p>E.g., col. 4, lines 14 to 16, "In the system described below, <i>there are two alarms: a Collision alarm, which is actuated when the vehicle is determined to be within the danger-of-collision distance; and a Safety alarm, which is actuated before the Collision alarm, at a distance greater than the danger-of-collision distance by a predetermined safety factor, e.g., 1.25.</i>"</p> <p>E.g., col. 6, lines 25 to 29, "Control panel 6 further includes a front distance display 46, in which are displayed the distance to the front vehicle (in region 46a), in which direction (by arrow 46b), and <i>whether or not there is a collision danger (region 46c).</i>"</p> <p>E.g., col. 6, lines 41 to 46, "Control panel 6 further includes a speaker 54 for producing an <i>audio alarm in the event of a collision danger, in addition to the visually-indicated alarms</i> of sections 46c and 48c of the displays 46 and 48."</p> <p>E.g., col. 8, lines 37 to 48, "The <i>microcomputer 4</i> as illustrated in FIGS. 6a, 6b is divided into various functional modules, as follows: <i>... a deceleration alarm module 93, which controls the Safety alarm and Collision alarm on the control panel, ...</i>"</p> <p>E.g., Figs. 3 and 6B (ref. no. 46C)</p>
<p>said processor</p>			<p>E.g., col. 8, lines 37 to 43, "The <i>microcomputer</i></p>

Limitation of '781 Patent Claim 26	Automotive Electronics Handbook (Jurgen)	German Patent Application Publication No. 29 26 070 (Volkswagen '070)	U.S. Patent No. 5,357,438 (Davidian)
<p>subsystem determining, based upon data received from said radar detector, said at least one sensor and said memory subsystem, when to activate said vehicle proximity alarm circuit.</p>			<p>4 as illustrated in FIGS. 6a, 6b is divided into various functional modules, as follows: a calculation module 90, <i>which receives data concerning the various parameters briefly described above</i> and as will be described more particularly below <i>to enable it to make the necessary computations for actuating the Safety alarm and the Collision alarm; ...</i></p> <p>E.g., col. 12, line 59 to col 13, line 11, "The system then makes the computations illustrated (as an example) in block 162 to determine the stopping distance SD, which is equal to the reaction distance plus the braking distance multiplied by a stopping factor ST and a safety factor SF. In the illustrated example, the stopping distance is the sum of the reaction distance and the braking distance. The reaction distance is the product of the reaction time, visibility condition, daylight condition, reaction factor and speed; and the braking distance is the product of the braking distance (as supplied by the manufacturer), road type, skidding danger, vehicle load and braking factor. <i>The stopping distance (SD) includes further safety factors, and determines when the safety alarm will be actuated to first alert the driver of an approaching collision danger.</i></p> <p><i>A determination is also made of the collision distance CD which is equal to the stopping distance SD divided by the collision safety factor CSF, e.g., 1.25 in the example illustrated above, such that should the distance between the vehicle and the object come within the collision distance CD, the collision alarm is then actuated."</i></p>



Limitation of '781 Patent Claim 26	Automotive Electronics Handbook (Jurgen)	German Patent Application Publication No. 29 26 070 (Volkswagen '070)	U.S. Patent No. 5,357,438 (Davidian)
			<p>E.g., col. 13, lines 17 to 22, "<i>Whenever the distance between the vehicle and an object to the front of the vehicle or to the rear of the vehicle comes within the stopping distance SD and the collision distance CD, the system operates according to the deceleration alarm module 93, as indicated by block 164.</i>"</p>

6. Claims 17–21 and 23 are Obvious in View of the Combination of Jurgen, Saturn '452, and Davidian

Limitation of '781 Patent Claim 17	Automotive Electronics Handbook (Jurgen)	U.S. Patent No. 5,477,452 (Saturn '452)	U.S. Patent No. 5,357,438 (Davidian)
<p>17. Apparatus for optimizing operation of a vehicle, comprising:</p>	<p>E.g., page 12.1, “The electronic engine control system consists of sensing devices which continuously measure the operating conditions of the engine, <i>an electronic control unit (ECU) which evaluates the sensor inputs using data tables and calculations and determines the output to the actuating devices</i>, and actuating devices which are commanded by the ECU to perform an action in response to the sensor inputs.</p> <p>The motive for using an electronic engine control system is to provide the needed accuracy and adaptability in order to minimize exhaust emissions and fuel consumption, <i>provide optimal driveability for all operating conditions</i>, minimize evaporative emissions, and provide system diagnosis when malfunctions occur.”</p>	<p>E.g., Abstract, “<i>A motor vehicle has a manual transmission and means for indicating to the operator a point in operation for upshifting to the next higher gear</i> from the present gear. <i>A method of determining the shift point</i> is provided based upon actual operating parameters of the motor vehicle effecting current wheel torque and predicted wheel torque in the next higher gear.”</p>	<p>E.g., col. 1, lines 1 to 2, “The present invention relates to <i>an anti-collision system for vehicles.</i>”</p>
<p>a radar detector, said radar detector determining a distance separating a vehicle having an engine and an object in front of said vehicle;</p>	<p>E.g., page 7.23, “Ultrasonics, infrared, laser, and <i>microwaves (radar) can be used in the detection of objects behind vehicles and in the blind areas.</i>”</p>		<p>E.g., col. 4, lines 52 to 66, “<i>Vehicle 2 further includes a front space sensor 8 for sensing the space in front of the vehicle, such as the presence of another vehicle, a corresponding rear space sensor 10, and a pair of side sensors 11.</i> All the space sensors are in the form of pulse (e.g., ultrasonic) transmitters and receivers, for determining the distance of the vehicle from an object, e.g., another vehicle, at front or rear. Space sensors may also be provided at the sides of the vehicle. Vehicle 2 is further equipped with a speed sensor 12 which may sense the speed of the vehicle in any known manner, for example using the speed measuring system of the vehicle itself, or a speed measuring system independent</p>

Limitation of '781 Patent Claim 17	Automotive Electronics Handbook (Jurgen)	U.S. Patent No. 5,477,452 (Saturn '452)	U.S. Patent No. 5,357,438 (Davidian)
			<p>of the vehicle, e.g., an acceleration sensor, or by calculations based on the Doppler effect, etc.”</p> <p>E.g., col. 10, lines 17 to 26, “FIG. 7 is a circuit diagram of the microcomputer 4 and the other components of the electrical system. The microprocessor is indicated by block 100, its power supply by block 102, and its watchdog circuit by block 104. <i>It includes a transmitter 106 and a receiver 108 for transmitting and receiving the pulses (e.g., RF, ultrasound, laser, IR, etc.) in the front space sensor 8 and the rear space sensor 10 for measuring the distance of the vehicle from objects in front of, and to the rear, of the vehicle, respectively.</i>”</p> <p>E.g., col. 10, lines 38 to 50, “As indicated earlier, the distance of the vehicle from an object is determined by the front space sensor 8 with respect to objects in front of the vehicle, and by the rear space sensor 10 with respect to objects at the rear of the vehicle. Each of these space sensors may be of known construction, including a transmitter as indicated at 106 in FIG. 7, and a receiver as indicated at 108. <i>Thus, pulses are continuously transmitted by each transmitter, and the echoes from the objects in front of or to the rear of the vehicle are received by the respective receiver. The computer then measures the round-trip time from the pulse transmission to the echo reception in order to determine the distance of the vehicle from the object.</i>”</p>
at least one sensor coupled to said vehicle	E.g., page 7.6, “There are several applications for rotational speed sensing. <i>First it is necessary to monitor engine speed.</i> This	E.g., col. 1, lines 31 to 33, “Conventional shift indicator calibration typically involves setting <i>manifold pressure</i> (MAP) thresholds at a variety of	E.g., col. 4, lines 60 to 66, “Vehicle 2 is further equipped with a <i>speed sensor 12 which may sense the speed of the vehicle in any known</i>

Limitation of '781 Patent Claim 17	Automotive Electronics Handbook (Jurgen)	U.S. Patent No. 5,477,452 (Saturn '452)	U.S. Patent No. 5,357,438 (Davidian)
<p>for monitoring operation thereof, said at least one sensor including a road speed sensor, a manifold pressure sensor, a throttle position sensor and an engine speed sensor;</p>	<p>information is used for transmission control, engine control, cruise control, and possibly for a tachometer. Electronics and electronic sensing in the automobile were brought about by the need for higher efficiency engines, better fuel economy, increased power and performance, and lower emissions. Second, <b>wheel speed sensing is required</b> for use in transmissions, cruise control, speedometers, antilock brake systems (ABS), traction control (ASR), variable ratio power steering assist, four-wheel steering, and possibly in inertial navigation and air bag deployment applications.”</p> <p>E.g., page 7.8, “In electronic transmission applications, <b>information from the road and engine speed sensors</b>, as well as torque data and throttle position are required for the MCU to select the optimum gear ratio.”</p> <p>E.g., page 2.5, “Automotive specification and testing guidelines have been developed and published by the Society of Automotive Engineers (SAE) specifically for <b>manifold absolute pressure (MAP) sensors</b>.”</p> <p>E.g., page 2.7, “Manifold absolute pressure (MAP) is used as an input to fuel and ignition control in internal combustion engine control systems. <b>The speed-density system that uses the MAP sensor</b> has been preferred over mass air flow (MAF) control because it's less expensive, but stricter emission standards are causing more manufacturers to use mass air flow for future models.”</p>	<p>speeds.”</p> <p>E.g., col. 2, lines 13 to 18, “Referring to FIG. 1, the reference numeral 10 generally designates a motor vehicle drivetrain comprising a spark ignition <b>internal combustion engine (engine)</b> 12, engine output shaft 10 and the combination of conventional manual clutch, gearbox and final drive assembly (manual drivetrain) 16.”</p> <p>E.g., col. 2, lines 42 to 44, “Control unit 42 receives inputs required by the present embodiment including <b>manifold absolute pressure (MAP)</b>, on line 46, <b>engine speed (Ne)</b> on line 50 and output speed (No) on line 54.”</p> <p>E.g., col. 7, lines 13 to 21, “Throttle position “%T” is checked at block 515 against a closed position threshold K3. Closed throttle is indicative of vehicle coast, a state of operation wherein the engine is not imparting torque to the drive wheels and thus does not necessitate an upshift. Closed throttle may also be indicative of the operator purposefully using the drivetrain to decelerate the vehicle. <b>Therefore, where a closed throttle is detected</b>, control bypasses the upshift threshold steps 530 and proceeds with execution of block 552.”</p> <p>E.g., FIG. 1:</p>	<p><b>manner</b>, for example using the speed measuring system of the vehicle itself, or a speed measuring system independent of the vehicle, e.g., an acceleration sensor, or by calculations based on the Doppler effect, etc.”</p>

Limitation of '781 Patent Claim 17	Automotive Electronics Handbook (Jurgen)	U.S. Patent No. 5,477,452 (Saturn '452)	U.S. Patent No. 5,357,438 (Davidian)
	<p>E.g., page 12.18, "To control the idle speed, the ECU uses inputs from the <i>throttle position sensor</i>, air conditioning, automatic transmission, power steering, charging system, engine RPM, and vehicle speed."</p> <p>E.g., page 12.21, "The electronic injection unit also houses the <i>throttle position sensor</i> and, in some cases, an inlet air temperature sensor which provides operating condition information to the ECU."</p>	<p style="text-align: center;">FIG. 1</p>	
<p>a processor subsystem, coupled to said radar detector and said at least one sensor, to receive data therefrom;</p>	<p>E.g., page 12.1, "The electronic engine control system consists of <i>sensing devices which continuously measure the operating conditions of the engine, an electronic control unit (ECU) which evaluates the sensor inputs</i> using data tables and calculations and determines the output to the actuating devices, and actuating devices which are commanded by the ECU to perform an action in response to the sensor inputs."</p> <p>E.g., page 22.6, "During the entire operating time of the vehicle, <i>the ECUs are constantly supervising the sensors they are connected to.</i>"</p> <p>E.g., page 13.4, "On the functional side, the hardware configuration can be divided into power supply, input signal transfer circuits, output stages, and <i>microcontroller</i>, including peripheral components and monitoring and</p>	<p>E.g., col. 2, lines 42 to 46, "<i>Control unit 42 receives inputs</i> required by the present embodiment including manifold absolute pressure (MAP), on line 46, engine speed (Ne) on line 50 and output speed (No) on line 54. Knock sensing means Kn are also shown providing signal input via line 56 to control unit 42."</p> <p>E.g., col. 2, lines 52 to 55, "<i>Control unit 42 may be mechanized with a conventional state of the art microcomputer controller</i> including a central processing unit, memory and input-output devices."</p> <p>E.g., FIG. 1:</p>	<p>E.g., col. 8, lines 29 to 43, "<i>FIGS. 6a, 6b, are a block diagram illustrating the microcomputer 4 and its inputs and outputs described earlier which enable it to continuously monitor the operation of the vehicle</i> and to actuate first a Safety alarm, and then a Collision alarm whenever the vehicle may enter a danger-of-collision situation according to the various preset parameters and automatic parameters introduced into the computer.</p> <p><i>The microcomputer 4 as illustrated in FIGS. 6a, 6b is divided into various functional modules, as follows: a calculation module 90, which receives data concerning the various parameters briefly described above and as will be described more particularly below to enable it to make the necessary computations for actuating the Safety alarm and the Collision alarm.</i>"</p> <p>E.g., col. 8, lines 58 to 60, "Thus, module 90</p>

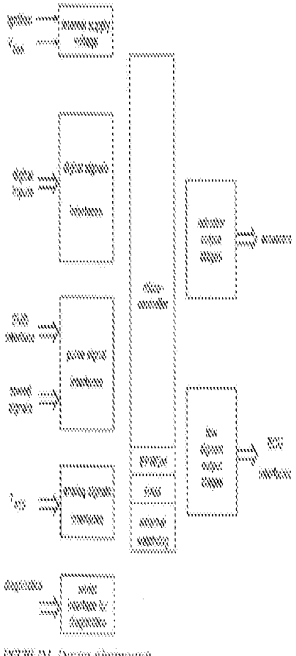
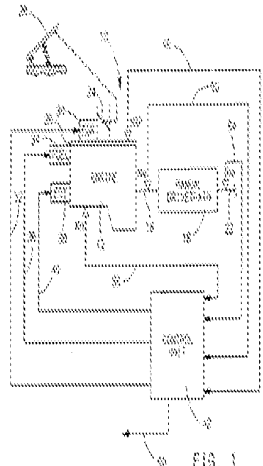
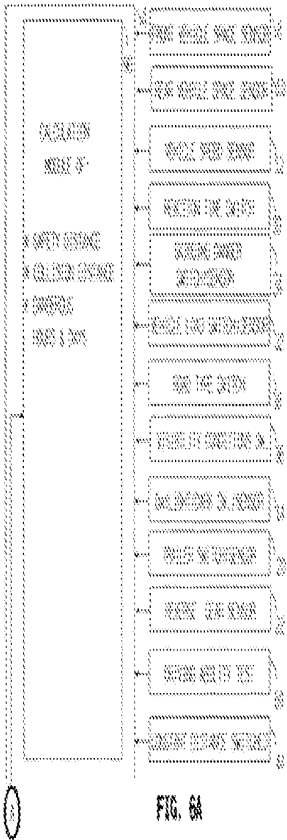
Limitation of '781 Patent Claim 17	Automotive Electronics Handbook (Jurgen)	U.S. Patent No. 5,477,452 (Saturn '452)	U.S. Patent No. 5,357,438 (Davidian)
	<p>safety circuits (Fig. 13.1)."</p> <p>E.g., Figure 13.1:</p>  <p>E.g., page 14.3, "The speed sensor is one of the most critical parts in the system, because the <i>microcontroller calculates the vehicle speed from the speed sensor's signal</i> to within 1/32 m/h."</p>		<p>receives inputs from the front space sensor 8, the rear space sensor 10, and the vehicle speed sensor 12."</p> <p>E.g., Figure 6A:</p> 
<p>a memory subsystem, coupled to said processor subsystem, said memory subsystem</p>	<p>E.g., page 13.5, "The calculators inside the control units are usually microcontrollers. . . . <i>The memory devices for program and data are usually EPROMS.</i> Their storage capacity is, in present applications, up to 64 Kbytes. Future applications will necessitate storage sizes up to 128 Kbytes. The failure storages for</p>	<p>E.g., col. 2, lines 52 to 55, "Control unit 42 may be mechanized with a conventional state of the art microcomputer controller including a central processing unit, <i>memory</i> and input-output devices."</p> <p>E.g., col. 6, lines 55 to 60, "First, <i>engine speed Ne is checked at block 511 to determine if it exceeds a</i></p>	<p>E.g., col. 9, lines 20 to 27, "<i>Computer module 90 also includes information about the vehicle braking distances as a function of speed. This is preferably in the form of a look-up table,</i> for example, provided by the manufacturer for predetermined defined conditions concerning road type, skidding danger, vehicle load and tires</p>

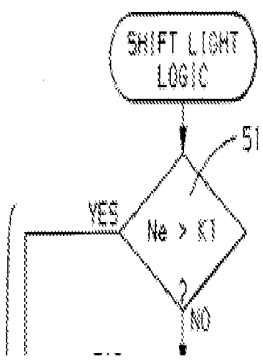
Limitation of '781 Patent Claim 17	Automotive Electronics Handbook (Jurgen)	U.S. Patent No. 5,477,452 (Saturn '452)	U.S. Patent No. 5,357,438 (Davidian)
<p>storing a first vehicle speed/stopping distance table, a manifold pressure set point, an RPM set point, a present level for each one of said at least one sensor and a prior level for each one of said at least one sensor;</p>	<p>diagnostics and the storage for adaptive data are in conventional applications, battery voltage-supplied RAMs. These are increasingly being replaced by EEPROMs.”</p> <p>E.g., page 12.9, “A subsystem of the fuel control system is lambda closed-loop control. . . .</p> <p>[T]he engine control unit uses an anticipatory control strategy that uses engine load and RPM to determine the approximate fuel requirement. <i>The engine load information is provided by the manifold pressure sensor for speed density systems and by the air meter for air flow and air mass measurement systems and by the throttle valve position sensor. The engine control unit contains data tables for combinations of load and RPM.</i> This allows for rapid response to changes in operating conditions. The lambda sensor still provides the feedback correction for each load/RPM point. . . .</p> <p>[T]he electronic control unit has a feature for adapting changes in the fuel required for the load/RPM points. <i>At each load/RPM point, the lambda sensor continuously provides information that allows the system to adjust the fuel to the commanded A/F ratio. The corrected information is stored in RAM (random access memory) so that the next time the engine reaches that operating point (load/RPM), the anticipatory value will require less correction. These values remain stored in the electronic control unit even after the engine is shut off.</i> Only if power to the</p>	<p><i>predetermined maximum allowable engine speed threshold K1.</i> If the threshold is exceeded then an upshift is required regardless of the value of UTR and control is therefore passed via line 560 to block 542 where the shift light flag is set to one (SL FLAG=1). If the threshold at block 511 is not exceeded, decision block 512 is encountered.”</p> <p>E.g., FIG. 5:</p>  <pre> graph TD     A[SHIFT LIGHT LOGIC] --&gt; B{Ne &gt; K1}     B -- YES --&gt; A     B -- NO --&gt; C[2]   </pre>	<p>pressure, and is stored in a ROM (read-only memory) of the microcomputer so that it can be changed periodically if necessary.”</p> <p>E.g., col. 12, line 59 to col 13, line 22, “The system then makes the computations illustrated (as an example) in block 162 to determine the stopping distance SD, which is equal to the reaction distance plus the braking distance multiplied by a stopping factor ST and a safety factor SF. <i>In the illustrated example, the stopping distance is the sum of the reaction distance and the braking distance. The reaction distance is the product of the reaction time, visibility condition, daylight condition, reaction factor and speed; and the braking distance is the product of the braking distance (as supplied by the manufacturer), road type, skidding danger, vehicle load and braking factor.</i> The stopping distance (SD) includes further safety factors, and determines when the safety alarm will be actuated to first alert the driver of an approaching collision danger.</p> <p><i>A determination is also made of the collision distance CD which is equal to the stopping distance SD divided by the collision safety factor CSF, e.g., 1.25 in the example illustrated above, such that should the distance between the vehicle and the object come within the collision distance CD, the collision alarm is then actuated.</i></p> <p>The foregoing calculations of stopping distance SD and collision distance CD with respect to objects at the front of the vehicle are also made with respect to objects at the rear of the vehicle,</p>

Limitation of '781 Patent Claim 17	Automotive Electronics Handbook (Jurgen)	U.S. Patent No. 5,477,452 (Saturn '452)	U.S. Patent No. 5,357,438 (Davidian)
	<p>electronic control unit is disrupted (i.e., due to a dead battery), will the correction be lost. In that case, the electronic control unit will revert back to the original production values that are written in ROM (read-only memory)."</p> <p>E.g., page 14.2, "Other safety-related items include <i>program code to detect abnormal operating conditions and preserving into memory the data points associated with the abnormal condition for later diagnostics.</i> Abnormal conditions, for example, could be an intermittent vehicle speed sensor, or erratic driver switch signals."</p> <p>E.g., pages 22.2 to 22.3, "The most important test points of control units and sensors are tied to a diagnostic connector which is plugged into the measuring instrument with a corresponding adapter for the respective vehicle. . . .</p> <p><i>Modern electronics in vehicles support diagnosis by comparing the registered actual value with the internally stored nominal values</i> with the help of control units and their self-diagnosis, thus detecting faults."</p>		<p>these calculations being RSD and RCD, respectively, also shown in block 162.</p> <p>Whenever the distance between the vehicle and an object to the front of the vehicle or to the rear of the vehicle comes within the stopping distance SD and the collision distance CD, the system operates according to the deceleration alarm module 93, as indicated by block 164."</p>
<p>a vehicle proximity alarm circuit coupled to said processor subsystem, said vehicle proximity alarm circuit issuing an alarm that said vehicle is too close to said</p>	<p>E.g., page 7.6, "[W]heel speed sensing is required for use in transmissions, cruise control, speedometers, antilock brake systems (ABS), traction control (ASR), variable ratio power steering assist, four-wheel steering, and possibly in inertial navigation and air bag deployment applications.</p> <p>Linear speed sensing can be used to measure the ground speed. This measurement also has the possibly of use in ABS, ASR, and inertial navigation. <i>Similar types of sensors can be</i></p>		<p>E.g., col. 3, lines 59 to 66, "The anti-collision system illustrated in FIGS. 1-14 is particularly useful for motor vehicles (passengers cars, buses, trucks) in order to <i>actuate an alarm when the vehicle is travelling at a distance behind another vehicle or in front of another</i>, which is equal to or less than a danger-of-collision distance computed by a computer such that if the front vehicle stops suddenly there is a danger of a rear-end collision."</p>



Limitation of '781 Patent Claim 17	Automotive Electronics Handbook (Jurgen)	U.S. Patent No. 5,477,452 (Saturn '452)	U.S. Patent No. 5,357,438 (Davidian)
object;	<p><i>used in crash avoidance, proximity, and obstacle detection applications.</i></p> <p>E.g., page 7.23, "Ultrasonics, infrared, laser, and microwaves (radar) can be used in the detection of objects behind vehicles and in the blind areas."</p>		<p>E.g., col. 4, lines 14 to 16, "In the system described below, <i>there are two alarms: a Collision alarm, which is actuated when the vehicle is determined to be within the danger-of-collision distance; and a Safety alarm, which is actuated before the Collision alarm, at a distance greater than the danger-of-collision distance by a predetermined safety factor, e.g., 1.25.</i>"</p> <p>E.g., col. 6, lines 25 to 29, "Control panel 6 further includes a front distance display 46, in which are displayed the distance to the front vehicle (in region 46a), in which direction (by arrow 46b), and <i>whether or not there is a collision danger (region 46c).</i>"</p> <p>E.g., col. 6, lines 41 to 46, "Control panel 6 further includes a speaker 54 for producing an <i>audio alarm in the event of a collision danger, in addition to the visually-indicated alarms</i> of sections 46c and 48c of the displays 46 and 48."</p> <p>E.g., col. 8, lines 37 to 48, "The <i>microcomputer 4</i> as illustrated in FIGS. 6a, 6b is divided into various functional modules, as follows:  <i>... a deceleration alarm module 93, which controls the Safety alarm and Collision alarm on the control panel, ...</i>"</p> <p>E.g., Figs. 3 and 6B (ref. no. 46C)</p>
a fuel overinjection circuit coupled to said processor subsystem, said	E.g., page 12.22, "During an acceleration transition, the ECU adds a correction factor (an increase) to the commanded injector pulse width. The sudden increase in air results in a lean mixture which must be corrected swiftly to		

Limitation of '781 Patent Claim 17	Automotive Electronics Handbook (Jurgen)	U.S. Patent No. 5,477,452 (Saturn '452)	U.S. Patent No. 5,357,438 (Davidian)
<p>fuel overinjection circuit issuing a notification that excessive fuel is being supplied to said engine of said vehicle;</p>	<p>obtain good transitional response. <i>During a deceleration transition, the fuel can be shut off by simply not providing a pulse width signal to the injector to minimize exhaust emissions and fuel consumption.</i></p> <p>E.g., page 12.4, "During coasting and braking, fuel consumption can be further reduced by shutting off the fuel until the engine speed decreases to slightly higher than the set idle speed. <i>The ECU determines when fuel shutoff can occur by evaluating the throttle position, engine RPM, and vehicle speed.</i>"</p> <p>E.g., page 12.14, "Using the inputs of engine RPM and vehicle speed to the electronic control unit, thresholds can be established for limiting these variables with fuel cutoff. <i>When the maximum speed is achieved, the fuel injectors are shut off.</i> When the speed decreases below the threshold, fuel injection resumes."</p> <p>E.g., page 12.17, "<i>During transition to fuel cutoff, the ignition timing is retarded from its current setting to reduce engine torque and to assist in engine braking. The fuel is then shut off.</i> During the transition, the throttle bypass valve or the main throttle valve may remain open for a short period to allow fresh air to oxidize the remaining unburned HC and CO to further reduce exhaust emissions. During development of the fuel cutoff strategy, the advantage of reduced emission effects and catalyst temperature control must be balanced against driveability requirements. The use of fuel cutoff may change the perceived amount</p>		

Limitation of '781 Patent Claim 17	Automotive Electronics Handbook (Jurgen)	U.S. Patent No. 5,477,452 (Saturn '452)	U.S. Patent No. 5,357,438 (Davidian)
	<p>of engine braking felt by the driver. In addition, care must be taken to avoid a 'bump' feel when entering the fuel cutoff mode, due to the change in torque."</p>		
<p>an upshift notification circuit coupled to said processor subsystem, said upshift notification circuit issuing a notification that said engine of said vehicle is being operated at an excessive speed;</p>	<p>E.g., page 13.7 to 13.9, "<i>The basic functions of the transmission control are the shift point control, the lockup control, engine torque control during shifting, related safety functions, and diagnostic functions for vehicle service.</i>"</p> <p>E.g., page 13.9, "The basic shift point control uses shift maps, which are defined in data in the unit memory. These shift maps are selectable over a wide range. <i>The shift point limitations are made, on the one hand, by the highest admissible engine speed for each application</i> and, on the other hand, by the lowest engine speed that is practical for driving comfort and noise emission. <i>The inputs of the shift point determination are the throttle position, the accelerator pedal position, and the vehicle speed</i> (determined by the transmission output speed)."</p> <p>E.g., page 13.14, "In addition to these functions, <i>different shift maps can be implemented into the data field of the TCU [Transmission Control Unit]</i>. For example, it is possible to have one shift map for low fuel consumption, which has shift points in the range of the best efficiency of the engine, and additionally to have another map for power operation, where the shift points are placed at points of highest engine output power."</p>	<p>E.g., Abstract, "<i>A motor vehicle has a manual transmission and means for indicating to the operator a point in operation for upshifting to the next higher gear</i> from the present gear. <i>A method of determining the shift point</i> is provided based upon actual operating parameters of the motor vehicle effecting current wheel torque and predicted wheel torque in the next higher gear."</p> <p>E.g., col. 1, lines 10 to 13, "Shift indicators are commonly used on manual transmission vehicles <i>to assist non-expert drivers in determining when it is appropriate to shift the transmission to a higher gear</i> in order to maximize driving fuel economy."</p> <p>E.g., col. 2, lines 42 to 55, "Control unit 42 receives inputs required by the present embodiment including manifold absolute pressure (MAP), on line 46, engine speed (Ne) on line 50 and output speed (No) on line 54. Knock sensing means Kn are also shown providing signal input via line 56 to control unit 42. <i>Control unit 42 indicates via line 60 the state of an upshift indicator light or equivalent visual display such as is found in conventional instrumentation in a motor vehicle. Line 60 may provide a logic signal to an instrument cluster for further processing or may drive a lamp directly via a power driver in control unit 42.</i> Control unit 42 may be mechanized with a conventional state of the art microcomputer controller including a central processing unit, memory and input-output devices."</p>	

Limitation of '781 Patent Claim 17	Automotive Electronics Handbook (Jurgen)	U.S. Patent No. 5,477,452 (Saturn '452)	U.S. Patent No. 5,357,438 (Davidian)
		<p>E.g., col. 3, lines 60 to 65, "Finally, <i>control unit 42 outputs a signal online [sic] 60 as shown in FIG. 1 for indicating the state of the upshift indicator light</i> as well as various other output signals for instrument cluster displays such as vehicle speedometer, oil pressure and coolant temperature for example."</p>	
<p>said processor subsystem determining, based upon data received from said radar detector, said at least one sensor and said memory subsystem, when to activate said vehicle proximity alarm circuit, when to activate said fuel overinjection circuit, and when to activate said upshift notification circuit.</p>	<p>E.g., page 12.4, "During coasting and braking, fuel consumption can be further reduced by shutting off the fuel until the engine speed decreases to slightly higher than the set idle speed. <i>The ECU determines when fuel shutoff can occur by evaluating the throttle position, engine RPM, and vehicle speed.</i>"</p> <p>E.g., page 12.14, "Using the inputs of engine RPM and vehicle speed to the electronic control unit, thresholds can be established for limiting these variables with fuel cutoff. <i>When the maximum speed is achieved, the fuel injectors are shut off.</i> When the speed decreases below the threshold, fuel injection resumes."</p> <p>E.g., page 13.7 to 13.9, "<i>The basic functions of the transmission control are the shift point control, the lockup control, engine torque control during shifting, related safety functions, and diagnostic functions for vehicle service.</i>"</p> <p>E.g., page 13.9, "The basic shift point control uses shift maps, which are defined in data in the unit memory. These shift maps are selectable over a wide range. <i>The shift point limitations are made</i>, on the one hand, by the highest admissible engine speed for each application and, on the other hand, <i>by the</i></p>	<p>E.g., col. 2, lines 42 to 55, "Control unit 42 receives inputs required by the present embodiment including manifold absolute pressure (MAP), on line 46, engine speed (Ne) on line 50 and output speed (No) on line 54. Knock sensing means Kn are also shown providing signal input via line 56 to control unit 42. <i>Control unit 42 indicates via line 60 the state of an upshift indicator light or equivalent visual display such as is found in conventional instrumentation in a motor vehicle. Line 60 may provide a logic signal to an instrument cluster for further processing or may drive a lamp directly via a power driver in control unit 42.</i> Control unit 42 may be mechanized with a conventional state of the art microcomputer controller including a central processing unit, memory and input-output devices."</p> <p>E.g., col. 3, lines 60 to 65, "Finally, <i>control unit 42 outputs a signal online [sic] 60 as shown in FIG. 1 for indicating the state of the upshift indicator light</i> as well as various other output signals for instrument cluster displays such as vehicle speedometer, oil pressure and coolant temperature for example."</p> <p>E.g., FIG. 1:</p>	<p>E.g., col. 8, lines 37 to 43, "The <i>microcomputer 4</i> as illustrated in FIGS. 6a, 6b is divided into various functional modules, as follows: a calculation module 90, <i>which receives data concerning the various parameters briefly described above</i> and as will be described more particularly below <i>to enable it to make the necessary computations for actuating the Safety alarm and the Collision alarm; ...</i>"</p> <p>E.g., col. 12, line 59 to col 13, line 11, "The system then makes the computations illustrated (as an example) in block 162 to determine the stopping distance SD, which is equal to the reaction distance plus the braking distance multiplied by a stopping factor ST and a safety factor SF. In the illustrated example, the stopping distance is the sum of the reaction distance and the braking distance. The reaction distance is the product of the reaction time, visibility condition, daylight condition, reaction factor and speed; and the braking distance is the product of the braking distance (as supplied by the manufacturer), road type, skidding danger, vehicle load and braking factor. <i>The stopping distance (SD) includes further safety factors, and determines when the safety alarm will be actuated to first alert the driver of an approaching collision danger.</i></p> <p><i>A determination is also made of the collision</i></p>

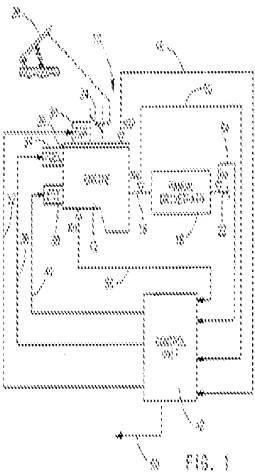
Limitation of '781 Patent Claim 17	Automotive Electronics Handbook (Jurgen)	U.S. Patent No. 5,477,452 (Saturn '452)	U.S. Patent No. 5,357,438 (Davidian)
	<p><i>lowest engine speed that is practical for driving comfort and noise emission. The inputs of the shift point determination are the throttle position, the accelerator pedal position, and the vehicle speed (determined by the transmission output speed)."</i></p>		<p><i>distance CD which is equal to the stopping distance SD divided by the collision safety factor CSF, e.g., 1.25 in the example illustrated above, such that should the distance between the vehicle and the object come within the collision distance CD, the collision alarm is then actuated."</i></p> <p>E.g., col. 13, lines 17 to 22, "<i>Whenever the distance between the vehicle and an object to the front of the vehicle or to the rear of the vehicle comes within the stopping distance SD and the collision distance CD, the system operates according to the deceleration alarm module 93, as indicated by block 164."</i></p>

Limitation of '781 Patent Claim 18	Automotive Electronics Handbook (Jurgen)	U.S. Patent No. 5,477,452 (Saturn '452)	U.S. Patent No. 5,357,438 (Davidian)
18. Apparatus for optimizing operation of a vehicle according to claim 17 wherein:	See claim 17 claim chart, at page A-153.	See claim 17 claim chart, at page A-153.	See claim 17 claim chart, at page A-153.
said at least one sensor further includes a windshield wiper sensor for indicating whether a windshield wiper of said vehicle is activated; and			<p>E.g., col. 4, line 67 to col. 5, line 2, "The automatic sensors on vehicle 2 further include a daylight sensor 14, <i>a rain sensor 16</i>, a vehicle load sensor 18, a trailer-hitch sensor 20, and a reverse gear sensor 22."</p> <p>E.g., col. 8, lines 58 to 63, "Thus, module 90 receives inputs from the front space sensor 8, the rear space sensor 10, and the vehicle speed sensor 12. <i>Module 90 also receives inputs from the sensors in case there is no depressible key, e.g., the daylight sensor 14, the trailer sensor 20, the reverse gear sensor 22, the rain sensor 16, and the vehicle load sensor 18.</i>"</p>
said memory subsystem further storing a second vehicle speed/stopping distance table.			<p>E.g., col. 9, lines 20 to 27, "<i>Computer module 90 also includes information about the vehicle braking distances as a function of speed. This is preferably in the form of a look-up table, for example, provided by the manufacturer for predetermined defined conditions concerning road type, skidding danger, vehicle load and tires pressure, and is stored in a ROM (read-only memory) of the microcomputer so that it can be changed periodically if necessary.</i>"</p> <p>E.g., col. 12, line 59 to col 13, line 22, "The system then makes the computations illustrated (as an example) in block 162 to determine the stopping distance SD, which is equal to the reaction distance plus the braking distance multiplied by a stopping factor ST and a safety factor SF. <i>In the illustrated example, the stopping distance is the sum of the</i></p>

Limitation of '781 Patent Claim 18	Automotive Electronics Handbook (Jurgen)	U.S. Patent No. 5,477,452 (Saturn '452)	U.S. Patent No. 5,357,438 (Davidian)
			<p><i>reaction distance and the braking distance.</i> The reaction distance is the product of the reaction time, visibility condition, daylight condition, reaction factor and speed; and <i>the braking distance is the product of the braking distance (as supplied by the manufacturer),</i> road type, <i>skidding danger,</i> vehicle load and braking factor. The stopping distance (SD) includes further safety factors, and determines when the safety alarm will be actuated to first alert the driver of an approaching collision danger.</p> <p>A determination is also made of the collision distance CD which is equal to the stopping distance SD divided by the collision safety factor CSF, e.g., 1.25 in the example illustrated above, such that should the distance between the vehicle and the object come within the collision distance CD, the collision alarm is then actuated.</p> <p>The foregoing calculations of stopping distance SD and collision distance CD with respect to objects at the front of the vehicle are also made with respect to objects at the rear of the vehicle, these calculations being RSD and RCD, respectively, also shown in block 162.</p> <p>Whenever the distance between the vehicle and an object to the front of the vehicle or to the rear of the vehicle comes within the stopping distance SD and the collision distance CD, the system operates according to the deceleration alarm module 93, as indicated by block 164.”</p>

Limitation of '781 Patent Claim 19	Automotive Electronics Handbook (Jurgen)	U.S. Patent No. 5,477,452 (Saturn '452)	U.S. Patent No. 5,357,438 (Davidian)
19. Apparatus for optimizing operation of a vehicle according to claim 17 and further comprising:	See claim 17 claim chart, at page A-153.	See claim 17 claim chart, at page A-153.	See claim 17 claim chart, at page A-153.
a throttle controller for controlling a throttle of said engine of said vehicle; and	E.g., page 14.4, "When the error signal has been computed, <i>an output signal to the servo actuators is generated to increase, hold, or decrease the throttle position.</i> . . . Throttle positioning is traditionally either a vacuum type servo or motor."		E.g., col. 2, line 67 to col. 3, line 2, "According to a further feature, the system includes an actuator for actuating a mechanical system of the vehicle, e.g., <i>the brakes of a train</i> , or steering of an aircraft, at the time the collision alarm is actuated."
said processor subsystem selectively reducing said throttle based upon data received from said radar detector, said at least one sensor and said memory subsystem.			<p>E.g., col. 2, line 67 to col. 3, line 2, "According to a further feature, the system includes an actuator for actuating a mechanical system of the vehicle, e.g., <i>the brakes of a train</i>, or steering of an aircraft, at the time the collision alarm is actuated."</p> <p>E.g., col. 8, lines 37 to 43, "The <i>microcomputer 4</i> as illustrated in FIGS. 6a, 6b is divided into various functional modules, as follows: a calculation module 90, <i>which receives data concerning the various parameters briefly described above</i> and as will be described more particularly below <i>to enable it to make the necessary computations for actuating the Safety alarm and the Collision alarm; ...</i>"</p> <p>E.g., col. 12, line 59 to col 13, line 11, "The system then makes the computations illustrated (as an example) in block 162 to determine the stopping distance SD, which is equal to the reaction distance plus the braking distance multiplied by a stopping factor ST and a safety factor SF. In the illustrated example, the stopping distance is the sum of the reaction distance and the braking distance. The</p>



Limitation of '781 Patent Claim 19	Automotive Electronics Handbook (Jürgen)	U.S. Patent No. 5,477,452 (Saturn '452)	U.S. Patent No. 5,357,438 (Davidian)
			<p>reaction distance is the product of the reaction time, visibility condition, daylight condition, reaction factor and speed; and the braking distance is the product of the braking distance (as supplied by the manufacturer), road type, skidding danger, vehicle load and braking factor. <i>The stopping distance (SD) includes further safety factors, and determines when the safety alarm will be actuated to first alert the driver of an approaching collision danger.</i></p> <p><i>A determination is also made of the collision distance CD which is equal to the stopping distance SD divided by the collision safety factor CSF, e.g., 1.25 in the example illustrated above, such that should the distance between the vehicle and the object come within the collision distance CD, the collision alarm is then actuated."</i></p> <p>E.g., col. 13, lines 17 to 22, "<i>Whenever the distance between the vehicle and an object to the front of the vehicle or to the rear of the vehicle comes within the stopping distance SD and the collision distance CD, the system operates according to the deceleration alarm module 93, as indicated by block 164.</i>"</p>

Limitation of '781 Patent Claim 20	Automotive Electronics Handbook (Jurgen)	German Patent Application Publication No. 29 26 070 (Volkswagen '070)	U.S. Patent No. 5,357,438 (Davidian)
20. Apparatus for optimizing operation of a vehicle according to claim 19 wherein	See claim 19 claim chart, at page A-167.	See claim 19 claim chart, at page A-167.	See claim 19 claim chart, at page A-167.
said at least one sensor further includes a brake sensor for indicating whether a brake system of said vehicle is activated.	E.g., pages 7.21 to 22, "In antilock brake systems, speed sensors are attached to all wheels to determine wheel rotation speed and slip differential between wheels . . . <b><i>Brake pedal position and brake fluid pressure information are also required for control.</i></b> "		E.g., col. 6, lines 25 to 34, "Control panel 6 further includes a front distance display 46, in which are displayed the distance to the front vehicle (in region 46a), in which direction (by arrow 46b), and whether or not there is a collision danger (region 46c). A similar display, shown at 48 and having regions 48a, 48b and 48c, is provided with respect to the rear of the vehicle equipped with the system, whether a rear collision danger exists, and <b><i>the status of the rear brake light.</i></b> "  E.g., col. 8, lines 37 to 57, "The microcomputer 4 as illustrated in FIGS. 6a, 6b is divided into various functional modules, as follows: . . . a deceleration alarm module 93, which controls the Safety alarm and Collision alarm on the control panel, <b><i>the brake light actuator 26 and (e.g., in the case of a train) the vehicle brakes automatically;</i></b> a black box module 94, which controls the information recorded into and read out of the black box 28; and a driving ability test module 95, involved in the driving ability test 60 in the control panel of FIG. 2, or 80 in the control panel of FIG. 5. The operation of each of these modules (except the clock 91) is described more particularly below with reference to the flow charts of FIGS. 9-14."

Limitation of '781 Patent Claim 21	Automotive Electronics Handbook (Jurgen)	U.S. Patent No. 5,477,452 (Saturn '452)	U.S. Patent No. 5,357,438 (Davidian)
21. Apparatus for optimizing operation of a vehicle according to claim 19 wherein said processor subsystem further comprises:	See claim 19 claim chart, at page A-167.	See claim 19 claim chart, at page A-167.	See claim 19 claim chart, at page A-167.
means for counting a total number of vehicle proximity alarms determined by said processor subsystem;			<p>E.g., col. 11, lines 7 to 11, "ALSF Alarm stopping front counter; ALSR Alarm stopping rear counter; ALCF Alarm collision front counter; ALCR Alarm collision rear counter."</p> <p>E.g., col. 11, lines 60 to 68, "The ALSF and ALSR counters, the ALCF and ALCR counters, and the ALFA and ALRA accumulators in the above table, and referred to in the flow charts below, would be provided in the black box 28 which records all the incidents in which the safety alarm and collision alarm were actuated, including the time, vehicle speed and vehicle distance for each alarm incident."</p> <p>E.g., col. 14, lines 8 to 12, "Whenever the measured distance is equal to or less than the stopping distance (block 225), the system increments the alarm stopping front counter (block 228), records the time, distance and speed in the black box, and also actuates the safety alarm (block 229)."</p>
means for selectively reducing said throttle based upon said total number of vehicle proximity alarms.			<p>E.g., col. 2, line 67 to col. 3, line 2, "According to a further feature, the system includes an actuator for actuating a mechanical system of the vehicle, e.g., <i>the brakes of a train</i>, or steering of an aircraft, at the time the collision alarm is actuated."</p> <p>E.g., col. 8, lines 37 to 43, "The <i>microcomputer 4</i> as illustrated in FIGS. 6a, 6b is divided into various functional modules, as follows: a calculation module 90, <i>which receives data concerning the various parameters briefly described above</i> and as will be described more particularly below <i>to enable it to make the necessary computations for actuating the Safety alarm and the Collision alarm; ...</i>"</p>

Limitation of '781 Patent Claim 21	Automotive Electronics Handbook (Jurgen)	U.S. Patent No. 5,477,452 (Saturn '452)	U.S. Patent No. 5,357,438 (Davidian)
			<p>E.g., col. 12, line 59 to col 13, line 11, "The system then makes the computations illustrated (as an example) in block 162 to determine the stopping distance SD, which is equal to the reaction distance plus the braking distance multiplied by a stopping factor ST and a safety factor SF. In the illustrated example, the stopping distance is the sum of the reaction distance and the braking distance. The reaction distance is the product of the reaction time, visibility condition, daylight condition, reaction factor and speed; and the braking distance is the product of the braking distance (as supplied by the manufacturer), road type, skidding danger, vehicle load and braking factor. <i>The stopping distance (SD) includes further safety factors, and determines when the safety alarm will be actuated to first alert the driver of an approaching collision danger.</i></p> <p><i>A determination is also made of the collision distance CD which is equal to the stopping distance SD divided by the collision safety factor CSF, e.g., 1.25 in the example illustrated above, such that should the distance between the vehicle and the object come within the collision distance CD, the collision alarm is then actuated."</i></p> <p>E.g., col. 13, lines 17 to 22, "<i>Whenever the distance between the vehicle and an object to the front of the vehicle or to the rear of the vehicle comes within the stopping distance SD and the collision distance CD, the system operates according to the deceleration alarm module 93, as indicated by block 164.</i>"</p>

Limitation of '781 Patent Claim 23	Automotive Electronics Handbook (Jurgen)	U.S. Patent No. 5,477,452 (Saturn '452)	U.S. Patent No. 5,357,438 (Davidian)
<p>23. Apparatus for optimizing operation of a vehicle, comprising:</p>	<p>E.g., page 12.1, "The electronic engine control system consists of sensing devices which continuously measure the operating conditions of the engine, <i>an electronic control unit (ECU) which evaluates the sensor inputs using data tables and calculations and determines the output to the actuating devices</i>, and actuating devices which are commanded by the ECU to perform an action in response to the sensor inputs.</p> <p>The motive for using an electronic engine control system is to provide the needed accuracy and adaptability in order to minimize exhaust emissions and fuel consumption, <i>provide optimal driveability for all operating conditions</i>, minimize evaporative emissions, and provide system diagnosis when malfunctions occur."</p>	<p>E.g., Abstract, "<i>A motor vehicle has a manual transmission and means for indicating to the operator a point in operation for upshifting to the next higher gear</i> from the present gear. <i>A method of determining the shift point</i> is provided based upon actual operating parameters of the motor vehicle effecting current wheel torque and predicted wheel torque in the next higher gear."</p>	<p>E.g., col. 1, lines 1 to 2, "The present invention relates to <i>an anti-collision system for vehicles.</i>"</p>
<p>a radar detector, said radar detector determining a distance separating a vehicle having an engine and an object in front of said vehicle;</p>	<p>E.g., page 7.23, "Ultrasonics, infrared, laser, and <i>microwaves (radar) can be used in the detection of objects behind vehicles and in the blind areas.</i>"</p>		<p>E.g., col. 4, lines 52 to 66, "<i>Vehicle 2 further includes a front space sensor 8 for sensing the space in front of the vehicle, such as the presence of another vehicle, a corresponding rear space sensor 10, and a pair of side sensors 11.</i> All the space sensors are in the form of pulse (e.g., ultrasonic) transmitters and receivers, for determining the distance of the vehicle from an object, e.g., another vehicle, at front or rear. Space sensors may also be provided at the sides of the vehicle. Vehicle 2 is further equipped with a speed sensor 12 which may sense the speed of the vehicle in any known manner, for example using the speed measuring system of the vehicle itself, or a speed measuring system independent of the vehicle, e.g., an acceleration sensor, or by</p>

Limitation of '781 Patent Claim 23	Automotive Electronics Handbook (Jurgen)	U.S. Patent No. 5,477,452 (Saturn '452)	U.S. Patent No. 5,357,438 (Davidian)
			<p>calculations based on the Doppler effect, etc.”</p> <p>E.g., col. 10, lines 17 to 26, “FIG. 7 is a circuit diagram of the microcomputer 4 and the other components of the electrical system. The microprocessor is indicated by block 100, its power supply by block 102, and its watchdog circuit by block 104. <i>It includes a transmitter 106 and a receiver 108 for transmitting and receiving the pulses (e.g., RF, ultrasound, laser, IR, etc.) in the front space sensor 8 and the rear space sensor 10 for measuring the distance of the vehicle from objects in front of, and to the rear, of the vehicle, respectively.</i>”</p> <p>E.g., col. 10, lines 38 to 50, “As indicated earlier, the distance of the vehicle from an object is determined by the front space sensor 8 with respect to objects in front of the vehicle, and by the rear space sensor 10 with respect to objects at the rear of the vehicle. Each of these space sensors may be of known construction, including a transmitter as indicated at 106 in FIG. 7, and a receiver as indicated at 108. <i>Thus, pulses are continuously transmitted by each transmitter, and the echoes from the objects in front of or to the rear of the vehicle are received by the respective receiver. The computer then measures the round-trip time from the pulse transmission to the echo reception in order to determine the distance of the vehicle from the object.</i>”</p>
a plurality of sensors coupled to a vehicle having an engine, said	E.g., page 7.6, “There are several applications for rotational speed sensing. <i>First it is necessary to monitor engine speed.</i> This information is used for transmission control, engine control, cruise control, and possibly for a	E.g., col. 1, lines 31 to 33, “Conventional shift indicator calibration typically involves setting <i>manifold pressure</i> (MAP) thresholds at a variety of speeds.”	E.g., col. 4, lines 60 to 66, “Vehicle 2 is further equipped with a <i>speed sensor 12 which may sense the speed of the vehicle in any known manner</i> , for example using the speed measuring system of the vehicle itself, or a speed measuring

Limitation of '781 Patent Claim 23	Automotive Electronics Handbook (Jurgen)	U.S. Patent No. 5,477,452 (Saturn '452)	U.S. Patent No. 5,357,438 (Davidian)
<p>plurality of sensors, which collectively monitor operation of said vehicle, including a road speed sensor, and engine speed sensor, a manifold pressure sensor and a throttle position sensor;</p>	<p>tachometer. Electronics and electronic sensing in the automobile were brought about by the need for higher efficiency engines, better fuel economy, increased power and performance, and lower emissions. Second, <i>wheel speed sensing is required</i> for use in transmissions, cruise control, speedometers, antilock brake systems (ABS), traction control (ASR), variable ratio power steering assist, four-wheel steering, and possibly in inertial navigation and air bag deployment applications.”</p> <p>E.g., page 7.8, “In electronic transmission applications, <i>information from the road and engine speed sensors</i>, as well as torque data and throttle position are required for the MCU to select the optimum gear ratio.”</p> <p>E.g., page 2.5, “Automotive specification and testing guidelines have been developed and published by the Society of Automotive Engineers (SAE) specifically for <i>manifold absolute pressure (MAP) sensors</i>.”</p> <p>E.g., page 2.7, “Manifold absolute pressure (MAP) is used as an input to fuel and ignition control in internal combustion engine control systems. <i>The speed-density system that uses the MAP sensor</i> has been preferred over mass air flow (MAF) control because it's less expensive, but stricter emission standards are causing more manufacturers to use mass air flow for future models.”</p> <p>E.g., page 12.18, “To control the idle speed, the ECU uses inputs from the <i>throttle position</i></p>	<p>E.g., col. 2, lines 13 to 18, “Referring to FIG. 1, the reference numeral 10 generally designates a motor vehicle drivetrain comprising a spark ignition <i>internal combustion engine (engine)</i> 12, engine output shaft 10 and the combination of conventional manual clutch, gearbox and final drive assembly (manual drivetrain) 16.”</p> <p>E.g., col. 2, lines 42 to 44, “Control unit 42 receives inputs required by the present embodiment including <i>manifold absolute pressure (MAP)</i>, on line 46, <i>engine speed (Ne)</i> on line 50 and output speed (No) on line 54.”</p> <p>E.g., col. 7, lines 13 to 21, “Throttle position “%T” is checked at block 515 against a closed position threshold K3. Closed throttle is indicative of vehicle coast, a state of operation wherein the engine is not imparting torque to the drive wheels and thus does not necessitate an upshift. Closed throttle may also be indicative of the operator purposefully using the drivetrain to decelerate the vehicle. <i>Therefore, where a closed throttle is detected</i>, control bypasses the upshift threshold steps 530 and proceeds with execution of block 552.”</p> <p>E.g., FIG. 1:</p>	<p>system independent of the vehicle, e.g., an acceleration sensor, or by calculations based on the Doppler effect, etc.”</p>

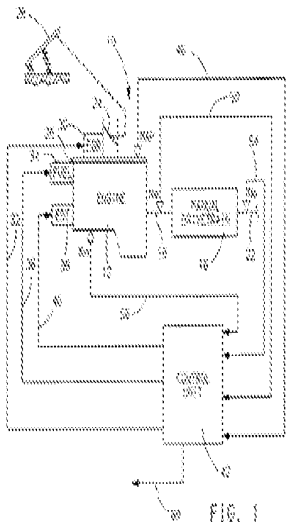
Limitation of '781 Patent Claim 23	Automotive Electronics Handbook (Jurgen)	U.S. Patent No. 5,477,452 (Saturn '452)	U.S. Patent No. 5,357,438 (Davidian)
	<p><i>sensor</i>, air conditioning, automatic transmission, power steering, charging system, engine RPM, and vehicle speed.”</p> <p>E.g., page 12.21, “The electronic injection unit also houses the <i>throttle position sensor</i> and, in some cases, an inlet air temperature sensor which provides operating condition information to the ECU.”</p>		
<p>a processor subsystem, coupled to said radar detector and each one of said plurality of sensors, to receive data therefrom;</p>	<p>E.g., page 12.1, “The electronic engine control system consists of <i>sensing devices which continuously measure the operating conditions of the engine, an electronic control unit (ECU) which evaluates the sensor inputs</i> using data tables and calculations and determines the output to the actuating devices, and actuating devices which are commanded by the ECU to perform an action in response to the sensor inputs.”</p> <p>E.g., page 22.6, “During the entire operating time of the vehicle, <i>the ECUs are constantly supervising the sensors they are connected to.</i>”</p> <p>E.g., page 13.4, “On the functional side, the hardware configuration can be divided into power supply, input signal transfer circuits, output stages, and <i>microcontroller</i>, including peripheral components and monitoring and safety circuits (Fig. 13.1).”</p>	<p>E.g., col. 2, lines 42 to 46, “<i>Control unit 42 receives inputs</i> required by the present embodiment including manifold absolute pressure (MAP), on line 46, engine speed (Ne) on line 50 and output speed (No) on line 54. Knock sensing means Kn are also shown providing signal input via line 56 to control unit 42.”</p> <p>E.g., col. 2, lines 52 to 55, “<i>Control unit 42 may be mechanized with a conventional state of the art microcomputer controller</i> including a central processing unit, memory and input-output devices.”</p> <p>E.g., FIG. 1:</p>	<p>E.g., col. 8, lines 29 to 43, “<i>FIGS. 6a, 6b, are a block diagram illustrating the microcomputer 4 and its inputs and outputs described earlier which enable it to continuously monitor the operation of the vehicle</i> and to actuate first a Safety alarm, and then a Collision alarm whenever the vehicle may enter a danger-of-collision situation according to the various preset parameters and automatic parameters introduced into the computer.</p> <p><i>The microcomputer 4 as illustrated in FIGS. 6a, 6b is divided into various functional modules, as follows: a calculation module 90, which receives data concerning the various parameters briefly described above and as will be described more particularly below to enable it to make the necessary computations for actuating the Safety alarm and the Collision alarm.</i>”</p> <p>E.g., col. 8, lines 58 to 60, “Thus, module 90</p>

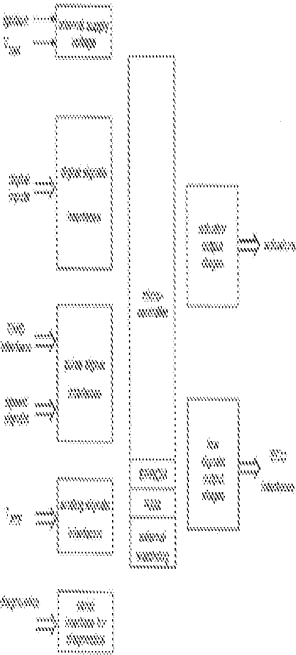
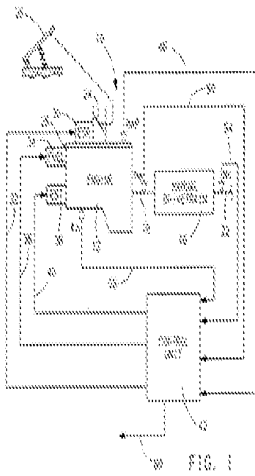
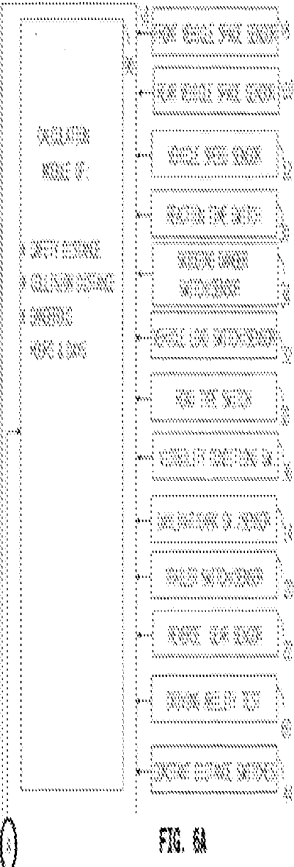

Limitation of '781 Patent Claim 23	Automotive Electronics Handbook (Jurgen)	U.S. Patent No. 5,477,452 (Saturn '452)	U.S. Patent No. 5,357,438 (Davidian)
	<p>E.g., Figure 13.1:</p>  <p>E.g., page 14.3, "The speed sensor is one of the most critical parts in the system, because the <i>microcontroller calculates the vehicle speed from the speed sensor's signal</i> to within 1/32 m/h."</p>	 <p>FIG. 1</p>	<p>receives inputs from the front space sensor 8, the rear space sensor 10, and the vehicle speed sensor 12."</p> <p>E.g., Figure 6A:</p>  <p>FIG. 6A</p>
<p>a memory subsystem, coupled to said processor subsystem, said memory</p>	<p>E.g., page 13.5, "The calculators inside the control units are usually microcontrollers. . . . <i>The memory devices for program and data are usually EPROMS.</i> Their storage capacity is, in present applications, up to 64 Kbytes. Future applications will necessitate storage sizes up to</p>	<p>E.g., col. 2, lines 52 to 55, "Control unit 42 may be mechanized with a conventional state of the art microcomputer controller including a central processing unit, <i>memory</i> and input-output devices."</p> <p>E.g., col. 6, lines 55 to 60, "First, <i>engine speed Ne is</i></p>	<p>E.g., col. 9, lines 20 to 27, "<i>Computer module 90 also includes information about the vehicle braking distances as a function of speed. This is preferably in the form of a look-up table,</i> for example, provided by the manufacturer for predetermined defined conditions concerning road</p>

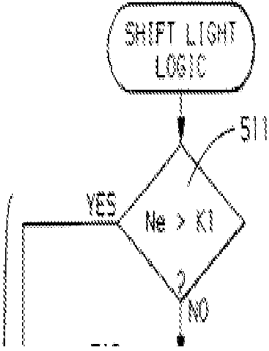
Limitation of '781 Patent Claim 23	Automotive Electronics Handbook (Jurgen)	U.S. Patent No. 5,477,452 (Saturn '452)	U.S. Patent No. 5,357,438 (Davidian)
<p>subsystem storing therein a first vehicle speed/stopping distance table, a manifold pressure set point, an RPM set point, and present and prior levels for each one of said plurality of sensors;</p>	<p>128 Kbytes. The failure storages for diagnostics and the storage for adaptive data are in conventional applications, battery voltage-supplied RAMs. These are increasingly being replaced by EEPROMs.”</p> <p>E.g., page 12.9, “A subsystem of the fuel control system is lambda closed-loop control. . . .</p> <p>[T]he engine control unit uses an anticipatory control strategy that uses engine load and RPM to determine the approximate fuel requirement. <i>The engine load information is provided by the manifold pressure sensor for speed density systems and by the air meter for air flow and air mass measurement systems and by the throttle valve position sensor. The engine control unit contains data tables for combinations of load and RPM.</i> This allows for rapid response to changes in operating conditions. The lambda sensor still provides the feedback correction for each load/RPM point. . . .</p> <p>[T]he electronic control unit has a feature for adapting changes in the fuel required for the load/RPM points. <i>At each load/RPM point, the lambda sensor continuously provides information that allows the system to adjust the fuel to the commanded A/F ratio. The corrected information is stored in RAM (random access memory) so that the next time the engine reaches that operating point (load/RPM), the anticipatory value will require less correction. These values remain stored in the electronic control unit even after the</i></p>	<p><i>checked at block 511 to determine if it exceeds a predetermined maximum allowable engine speed threshold K1.</i> If the threshold is exceeded then an upshift is required regardless of the value of UTR and control is therefore passed via line 560 to block 542 where the shift light flag is set to one (SL FLAG=1). If the threshold at block 511 is not exceeded, decision block 512 is encountered.”</p> <p>E.g., FIG. 5:</p>  <pre> graph TD     Start(( )) --&gt; 511{Ne &gt; K1}     511 -- YES --&gt; Start     511 -- NO --&gt; 512[ ]     </pre>	<p>type, skidding danger, vehicle load and tires pressure, and is <i>stored in a ROM (read-only memory) of the microcomputer so that it can be changed periodically if necessary.</i>”</p> <p>E.g., col. 12, line 59 to col 13, line 22, “The system then makes the computations illustrated (as an example) in block 162 to determine the stopping distance SD, which is equal to the reaction distance plus the braking distance multiplied by a stopping factor ST and a safety factor SF. <i>In the illustrated example, the stopping distance is the sum of the reaction distance and the braking distance. The reaction distance is the product of the reaction time, visibility condition, daylight condition, reaction factor and speed; and the braking distance is the product of the braking distance (as supplied by the manufacturer), road type, skidding danger, vehicle load and braking factor.</i> The stopping distance (SD) includes further safety factors, and determines when the safety alarm will be actuated to first alert the driver of an approaching collision danger.</p> <p><i>A determination is also made of the collision distance CD which is equal to the stopping distance SD divided by the collision safety factor CSF, e.g., 1.25 in the example illustrated above, such that should the distance between the vehicle and the object come within the collision distance CD, the collision alarm is then actuated.</i></p> <p>The foregoing calculations of stopping distance SD and collision distance CD with respect to objects at the front of the vehicle are also made with respect to objects at the rear of the vehicle,</p>

Limitation of '781 Patent Claim 23	Automotive Electronics Handbook (Jurgen)	U.S. Patent No. 5,477,452 (Saturn '452)	U.S. Patent No. 5,357,438 (Davidian)
	<p><i>engine is shut off.</i> Only if power to the electronic control unit is disrupted (i.e., due to a dead battery), will the correction be lost. In that case, the electronic control unit will revert back to the original production values that are written in ROM (read-only memory)."</p> <p>E.g., page 14.2, "Other safety-related items include <i>program code to detect abnormal operating conditions and preserving into memory the data points associated with the abnormal condition for later diagnostics.</i> Abnormal conditions, for example, could be an intermittent vehicle speed sensor, or erratic driver switch signals."</p> <p>E.g., pages 22.2 to 22.3, "The most important test points of control units and sensors are tied to a diagnostic connector which is plugged into the measuring instrument with a corresponding adapter for the respective vehicle. . . .</p> <p><i>Modern electronics in vehicles support diagnosis by comparing the registered actual value with the internally stored nominal values</i> with the help of control units and their self-diagnosis, thus detecting faults."</p>		<p>these calculations being RSD and RCD, respectively, also shown in block 162.</p> <p>Whenever the distance between the vehicle and an object to the front of the vehicle or to the rear of the vehicle comes within the stopping distance SD and the collision distance CD, the system operates according to the deceleration alarm module 93, as indicated by block 164."</p>
a fuel overinjection notification circuit coupled to said processor subsystem, said fuel overinjection notification	<p>E.g., page 12.22, "During an acceleration transition, the ECU adds a correction factor (an increase) to the commanded injector pulse width. The sudden increase in air results in a lean mixture which must be corrected swiftly to obtain good transitional response. <i>During a deceleration transition, the fuel can be shut off by simply not providing a pulse width signal to the injector to minimize exhaust emissions and fuel consumption.</i>"</p>		

Limitation of '781 Patent Claim 23	Automotive Electronics Handbook (Jurgen)	U.S. Patent No. 5,477,452 (Saturn '452)	U.S. Patent No. 5,357,438 (Davidian)
<p>circuit issuing a notification that excessive fuel is being supplied to said engine of said vehicle;</p>	<p>E.g., page 12.4, "During coasting and braking, fuel consumption can be further reduced by shutting off the fuel until the engine speed decreases to slightly higher than the set idle speed. <i>The ECU determines when fuel shutoff can occur by evaluating the throttle position, engine RPM, and vehicle speed.</i>"</p> <p>E.g., page 12.14, "Using the inputs of engine RPM and vehicle speed to the electronic control unit, thresholds can be established for limiting these variables with fuel cutoff. <i>When the maximum speed is achieved, the fuel injectors are shut off.</i> When the speed decreases below the threshold, fuel injection resumes."</p> <p>E.g., page 12.17, "<i>During transition to fuel cutoff, the ignition timing is retarded from its current setting to reduce engine torque and to assist in engine braking. The fuel is then shut off.</i> During the transition, the throttle bypass valve or the main throttle valve may remain open for a short period to allow fresh air to oxidize the remaining unburned HC and CO to further reduce exhaust emissions. During development of the fuel cutoff strategy, the advantage of reduced emission effects and catalyst temperature control must be balanced against driveability requirements. The use of fuel cutoff may change the perceived amount of engine braking felt by the driver. In addition, care must be taken to avoid a 'bump' feel when entering the fuel cutoff mode, due to the change in torque."</p>		
<p>an upshift</p>	<p>E.g., page 13.7 to 13.9, "<i>The basic functions of</i></p>	<p>E.g., Abstract, "<i>A motor vehicle has a manual</i></p>	

Limitation of '781 Patent Claim 23	Automotive Electronics Handbook (Jurgen)	U.S. Patent No. 5,477,452 (Saturn '452)	U.S. Patent No. 5,357,438 (Davidian)
<p>notification circuit coupled to said processor subsystem, said upshift notification circuit issuing a notification that said engine of said vehicle is being operated at an excessive engine speed;</p>	<p><i>the transmission control are the shift point control</i>, the lockup control, engine torque control during shifting, related safety functions, and diagnostic functions for vehicle service.”</p> <p>E.g., page 13.9, “The basic shift point control uses shift maps, which are defined in data in the unit memory. These shift maps are selectable over a wide range. <i>The shift point limitations are made, on the one hand, by the highest admissible engine speed for each application</i> and, on the other hand, by the lowest engine speed that is practical for driving comfort and noise emission. <i>The inputs of the shift point determination are the throttle position, the accelerator pedal position, and the vehicle speed</i> (determined by the transmission output speed).”</p> <p>E.g., page 13.14, “In addition to these functions, <i>different shift maps can be implemented into the data field of the TCU [Transmission Control Unit]</i>. For example, it is possible to have one shift map for low fuel consumption, which has shift points in the range of the best efficiency of the engine, and additionally to have another map for power operation, where the shift points are placed at points of highest engine output power.”</p>	<p><i>transmission and means for indicating to the operator a point in operation for upshifting to the next higher gear</i> from the present gear. <i>A method of determining the shift point</i> is provided based upon actual operating parameters of the motor vehicle effecting current wheel torque and predicted wheel torque in the next higher gear.”</p> <p>E.g., col. 1, lines 10 to 13, “Shift indicators are commonly used on manual transmission vehicles <i>to assist non-expert drivers in determining when it is appropriate to shift the transmission to a higher gear</i> in order to maximize driving fuel economy.”</p> <p>E.g., col. 2, lines 42 to 55, “Control unit 42 receives inputs required by the present embodiment including manifold absolute pressure (MAP), on line 46, engine speed (Ne) on line 50 and output speed (No) on line 54. Knock sensing means Kn are also shown providing signal input via line 56 to control unit 42. <i>Control unit 42 indicates via line 60 the state of an upshift indicator light or equivalent visual display such as is found in conventional instrumentation in a motor vehicle. Line 60 may provide a logic signal to an instrument cluster for further processing or may drive a lamp directly via a power driver in control unit 42.</i> Control unit 42 may be mechanized with a conventional state of the art microcomputer controller including a central processing unit, memory and input-output devices.”</p> <p>E.g., col. 3, lines 60 to 65, “Finally, <i>control unit 42 outputs a signal online [sic] 60 as shown in FIG. 1 for indicating the state of the upshift indicator light</i> as well as various other output signals for instrument cluster displays such as vehicle speedometer, oil pressure and coolant temperature for example.”</p>	

Limitation of '781 Patent Claim 23	Automotive Electronics Handbook (Jurgen)	U.S. Patent No. 5,477,452 (Saturn '452)	U.S. Patent No. 5,357,438 (Davidian)
<p>said processor subsystem determining, based upon data received from said plurality of sensors, when to activate said fuel overinjection circuit and when to activate said upshift notification circuit;</p>	<p>E.g., page 12.4, "During coasting and braking, fuel consumption can be further reduced by shutting off the fuel until the engine speed decreases to slightly higher than the set idle speed. <i>The ECU determines when fuel shutoff can occur by evaluating the throttle position, engine RPM, and vehicle speed.</i>"</p> <p>E.g., page 12.14, "Using the inputs of engine RPM and vehicle speed to the electronic control unit, thresholds can be established for limiting these variables with fuel cutoff. <i>When the maximum speed is achieved, the fuel injectors are shut off.</i> When the speed decreases below the threshold, fuel injection resumes."</p> <p>E.g., page 13.7 to 13.9, "<i>The basic functions of the transmission control are the shift point control, the lockup control, engine torque control during shifting, related safety functions, and diagnostic functions for vehicle service.</i>"</p> <p>E.g., page 13.9, "The basic shift point control uses shift maps, which are defined in data in the unit memory. These shift maps are selectable over a wide range. <i>The shift point limitations are made</i>, on the one hand, by the highest admissible engine speed for each application and, on the other hand, <i>by the lowest engine speed that is practical for driving comfort and noise emission. The inputs of the shift point determination are the throttle position, the accelerator pedal position, and the vehicle speed</i> (determined by the transmission output speed)."</p>	<p>E.g., col. 2, lines 42 to 55, "Control unit 42 receives inputs required by the present embodiment including manifold absolute pressure (MAP), on line 46, engine speed (Ne) on line 50 and output speed (No) on line 54. Knock sensing means Kn are also shown providing signal input via line 56 to control unit 42. <i>Control unit 42 indicates via line 60 the state of an upshift indicator light or equivalent visual display such as is found in conventional instrumentation in a motor vehicle. Line 60 may provide a logic signal to an instrument cluster for further processing or may drive a lamp directly via a power driver in control unit 42.</i> Control unit 42 may be mechanized with a conventional state of the art microcomputer controller including a central processing unit, memory and input-output devices."</p> <p>E.g., col. 3, lines 60 to 65, "Finally, <i>control unit 42 outputs a signal online [sic] 60 as shown in FIG. 1 for indicating the state of the upshift indicator light</i> as well as various other output signals for instrument cluster displays such as vehicle speedometer, oil pressure and coolant temperature for example."</p> <p>E.g., FIG. 1:</p>	

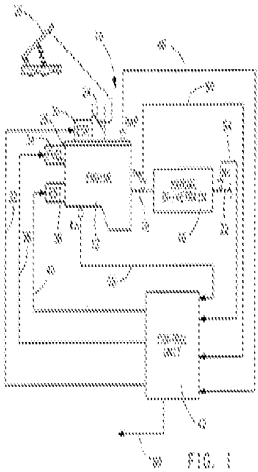
Limitation of '781 Patent Claim 23	Automotive Electronics Handbook (Jurgen)	U.S. Patent No. 5,477,452 (Saturn '452)	U.S. Patent No. 5,357,438 (Davidian)
			
<p>a vehicle proximity alarm circuit coupled to said processor subsystem, said vehicle proximity alarm circuit issuing an alarm that said vehicle is too close to said object;</p>			<p>E.g., col. 3, lines 59 to 66, “The anti-collision system illustrated in FIGS. 1-14 is particularly useful for motor vehicles (passengers cars, buses, trucks) in order to <i>actuate an alarm when the vehicle is travelling at a distance behind another vehicle or in front of another</i>, which is equal to or less than a danger-of-collision distance computed by a computer such that if the front vehicle stops suddenly there is a danger of a rear-end collision.”</p> <p>E.g., col. 4, lines 14 to 16, “In the system described below, <i>there are two alarms: a Collision alarm, which is actuated when the vehicle is determined to be within the danger-of-collision distance; and a Safety alarm, which is actuated before the Collision alarm, at a distance greater than the danger-of-collision distance by a predetermined safety factor, e.g., 1.25.</i>”</p> <p>E.g., col. 6, lines 25 to 29, “Control panel 6 further includes a front distance display 46, in which are displayed the distance to the front</p>

Limitation of '781 Patent Claim 23	Automotive Electronics Handbook (Jurgen)	U.S. Patent No. 5,477,452 (Saturn '452)	U.S. Patent No. 5,357,438 (Davidian)
			<p>vehicle (in region 46a), in which direction (by arrow 46b), and <i>whether or not there is a collision danger (region 46c).</i>"</p> <p>E.g., col. 6, lines 41 to 46, "Control panel 6 further includes a speaker 54 for producing an <i>audio alarm in the event of a collision danger, in addition to the visually-indicated alarms</i> of sections 46c and 48c of the displays 46 and 48."</p> <p>E.g., col. 8, lines 37 to 48, "The <i>microcomputer 4</i> as illustrated in FIGS. 6a, 6b is divided into various functional modules, as follows:  <i>... a deceleration alarm module 93, which controls the Safety alarm and Collision alarm on the control panel, ...</i>"</p> <p>E.g., Figs. 3 and 6B (ref. no. 46C)</p>
<p>said processor subsystem determining, based upon data received from said radar detector, said at least one sensor and said memory subsystem, when to activate said vehicle proximity alarm circuit.</p>			<p>E.g., col. 8, lines 37 to 43, "The <i>microcomputer 4</i> as illustrated in FIGS. 6a, 6b is divided into various functional modules, as follows: a calculation module 90, <i>which receives data concerning the various parameters briefly described above</i> and as will be described more particularly below <i>to enable it to make the necessary computations for actuating the Safety alarm and the Collision alarm; ...</i>"</p> <p>E.g., col. 12, line 59 to col 13, line 11, "The system then makes the computations illustrated (as an example) in block 162 to determine the stopping distance SD, which is equal to the reaction distance plus the braking distance multiplied by a stopping factor ST and a safety factor SF. In the illustrated example, the stopping distance is the sum of the reaction distance and</p>



Limitation of '781 Patent Claim 23	Automotive Electronics Handbook (Jurgen)	U.S. Patent No. 5,477,452 (Saturn '452)	U.S. Patent No. 5,357,438 (Davidian)
			<p>the braking distance. The reaction distance is the product of the reaction time, visibility condition, daylight condition, reaction factor and speed; and the braking distance is the product of the braking distance (as supplied by the manufacturer), road type, skidding danger, vehicle load and braking factor. <i>The stopping distance (SD) includes further safety factors, and determines when the safety alarm will be actuated to first alert the driver of an approaching collision danger.</i></p> <p><i>A determination is also made of the collision distance CD which is equal to the stopping distance SD divided by the collision safety factor CSF, e.g., 1.25 in the example illustrated above, such that should the distance between the vehicle and the object come within the collision distance CD, the collision alarm is then actuated."</i></p> <p>E.g., col. 13, lines 17 to 22, "<i>Whenever the distance between the vehicle and an object to the front of the vehicle or to the rear of the vehicle comes within the stopping distance SD and the collision distance CD, the system operates according to the deceleration alarm module 93, as indicated by block 164.</i>"</p>

**7. Claims 28–30 are Obvious in View of the Combination of Jurgen and Nissan '055**

Limitation of '781 Patent Claim 28	Automotive Electronics Handbook (Jurgen)	U.S. Patent No. 4,061,055 (Nissan '055)
<p>28. Apparatus for optimizing operation of a vehicle, comprising:</p>	<p>E.g., page 12.1, “The electronic engine control system consists of sensing devices which continuously measure the operating conditions of the engine, <i>an electronic control unit (ECU) which evaluates the sensor inputs using data tables and calculations and determines the output to the actuating devices</i>, and actuating devices which are commanded by the ECU to perform an action in response to the sensor inputs.</p> <p>The motive for using an electronic engine control system is to provide the needed accuracy and adaptability in order to minimize exhaust emissions and fuel consumption, <i>provide optimal driveability for all operating conditions</i>, minimize evaporative emissions, and provide system diagnosis when malfunctions occur.”</p>	<p>E.g., Abstract, “A control system which controls the number of fuel injected cylinders is used with an electronic type of automatic transmission system and includes compensating means or an engine operating parameter changing unit for changing a parameter fed to the transmission system to properly operate the same, thus increasing fuel economy or reducing fuel consumption.”</p>
<p>a plurality of sensors coupled to a vehicle having an engine, said plurality of sensors, which collectively monitor operation of said vehicle, including a road speed sensor, a manifold pressure sensor and a throttle position sensor;</p>	<p>E.g., page 7.6, “There are several applications for rotational speed sensing. <i>First it is necessary to monitor engine speed</i>. This information is used for transmission control, engine control, cruise control, and possibly for a tachometer. Electronics and electronic sensing in the automobile were brought about by the need for higher efficiency engines, better fuel economy, increased power and performance, and lower emissions. Second, <i>wheel speed sensing is required</i> for use in transmissions, cruise control, speedometers, antilock brake systems (ABS), traction control (ASR), variable ratio power steering assist, four-wheel steering, and possibly in inertial navigation and air bag deployment applications.”</p> <p>E.g., page 7.8, “In electronic transmission applications, <i>information from the road and engine speed sensors</i>, as well as torque data and throttle position are required for the MCU to select the optimum gear ratio.”</p> <p>E.g., page 2.5, “Automotive specification and testing guidelines have been developed and published by the</p>	<p>E.g., col. 2, lines 51 to 54, “The determination of the number of the cylinders to which fuel is injected is performed based on signals from a throttle opening sensor 1 and a vehicle velocity sensor 2.”</p> <p>E.g., FIG. 1:</p>

Limitation of '781 Patent Claim 28	Automotive Electronics Handbook (Jurgen)	U.S. Patent No. 4,061,055 (Nissan '055)
	<p>Society of Automotive Engineers (SAE) specifically for <i>manifold absolute pressure (MAP) sensors</i>.”</p> <p>E.g., page 2.7, “Manifold absolute pressure (MAP) is used as an input to fuel and ignition control in internal combustion engine control systems. <i>The speed-density system that uses the MAP sensor</i> has been preferred over mass air flow (MAF) control because it's less expensive, but stricter emission standards are causing more manufacturers to use mass air flow for future models.”</p> <p>E.g., page 12.18, “To control the idle speed, the ECU uses inputs from the <i>throttle position sensor</i>, air conditioning, automatic transmission, power steering, charging system, engine RPM, and vehicle speed.”</p> <p>E.g., page 12.21, “The electronic injection unit also houses the <i>throttle position sensor</i> and, in some cases, an inlet air temperature sensor which provides operating condition information to the ECU.”</p>	<p><b>FIG. 1</b></p> <pre> graph TD     1[THROTTLE OPENING SENSOR] --&gt; 4[CONTROL UNIT FOR DETERMINING THE NUMBER OF FUEL-INJECTED CYLINDERS]     2[VEHICLE VELOCITY SENSOR] --&gt; 4     4 --&gt; 3[FUEL INJECTION VALVES]     4 --&gt; 5[FUEL INJECTION CONTROL UNIT]     6[COMPENSATING MEANS] --&gt; 4     7[TRANSMISSION CONTROL UNIT] --&gt; 4   </pre> <p>See also Col. 1, lines 63 to 64.</p>
<p>a processor subsystem, coupled to each one of said plurality of sensors, to receive data therefrom;</p>	<p>E.g., page 12.1, “The electronic engine control system consists of <i>sensing devices which continuously measure the operating conditions of the engine, an electronic control unit (ECU) which evaluates the sensor inputs</i> using data tables and calculations and determines the output to the actuating devices, and actuating devices which are commanded by the ECU to perform an action in response to the sensor inputs.”</p> <p>E.g., page 22.6, “During the entire operating time of the vehicle, <i>the ECUs are constantly supervising the sensors they are connected to</i>.”</p> <p>E.g., page 13.4, “On the functional side, the hardware configuration can be divided into power supply, input signal transfer circuits, output stages, and <i>microcontroller</i>, including peripheral components and</p>	<p>E.g., col. 2, lines 47 to 49, “The control unit 4 determines the number of cylinders to which fuel is injected, and controls fuel injection through a plurality of fuel injection valves 3 which are respectively positioned on the cylinders.”</p> <p>E.g., col. 2, lines 51 to 54, “The determination of the number of the cylinders to which fuel is injected is performed based on signals from a throttle opening sensor 1 and a vehicle velocity sensor 2.”</p> <p>E.g., FIG. 1:</p>

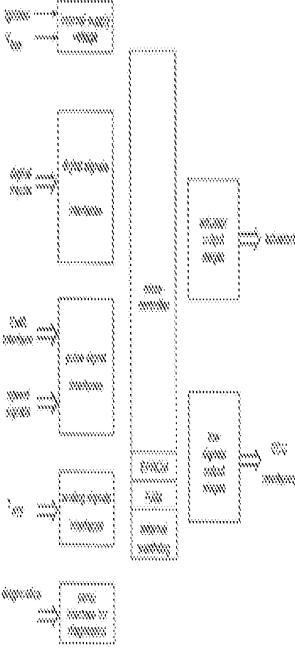
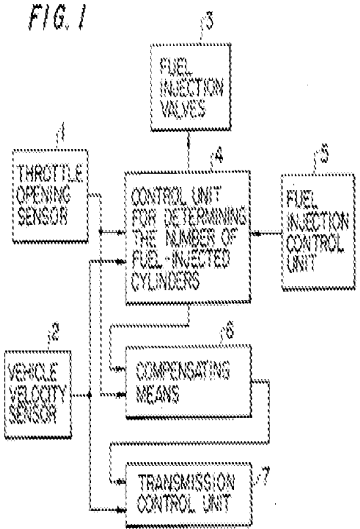
Limitation of '781 Patent Claim 28	Automotive Electronics Handbook (Jurgen)	U.S. Patent No. 4,061,055 (Nissan '055)
	<p>monitoring and safety circuits (Fig. 13.1.)”</p> <p>E.g., Figure 13.1:</p>  <p>E.g., page 14.3, “The speed sensor is one of the most critical parts in the system, because the <i>microcontroller calculates the vehicle speed from the speed sensor’s signal</i> to within 1/32 m/h.”</p>	<p><b>FIG. 1</b></p> 
<p>a fuel overinjection notification circuit coupled to said processor subsystem, said fuel overinjection notification circuit issuing a notification that excessive fuel is being supplied to said engine of said vehicle;</p>	<p>E.g., page 12.22, “During an acceleration transition, the ECU adds a correction factor (an increase) to the commanded injector pulse width. The sudden increase in air results in a lean mixture which must be corrected swiftly to obtain good transitional response. <i>During a deceleration transition, the fuel can be shut off by simply not providing a pulse width signal to the injector to minimize exhaust emissions and fuel consumption.</i>”</p> <p>E.g., page 12.4, “During coasting and braking, fuel</p>	<p>E.g., col. 2, lines 59 to 66, “With this arrangement, when the signal from the vehicle velocity sensor 2 exceeds a predetermined level and at the same time the signal from the throttle opening sensor 1 falls below another predetermined level, the control unit 4 determines the number of cylinders to which fuel is actually injected based on the two signals applied and stops injection of fuel to specified one or more cylinders.”</p>

Limitation of '781 Patent Claim 28	Automotive Electronics Handbook (Jurgen)	U.S. Patent No. 4,061,055 (Nissan '055)
	<p>consumption can be further reduced by shutting off the fuel until the engine speed decreases to slightly higher than the set idle speed. <i>The ECU determines when fuel shutoff can occur by evaluating the throttle position, engine RPM, and vehicle speed.</i></p> <p>E.g., page 12.14, "Using the inputs of engine RPM and vehicle speed to the electronic control unit, thresholds can be established for limiting these variables with fuel cutoff. <i>When the maximum speed is achieved, the fuel injectors are shut off.</i> When the speed decreases below the threshold, fuel injection resumes."</p> <p>E.g., page 12.17, "<i>During transition to fuel cutoff, the ignition timing is retarded from its current setting to reduce engine torque and to assist in engine braking. The fuel is then shut off.</i> During the transition, the throttle bypass valve or the main throttle valve may remain open for a short period to allow fresh air to oxidize the remaining unburned HC and CO to further reduce exhaust emissions. During development of the fuel cutoff strategy, the advantage of reduced emission effects and catalyst temperature control must be balanced against driveability requirements. The use of fuel cutoff may change the perceived amount of engine braking felt by the driver. In addition, care must be taken to avoid a 'bump' feel when entering the fuel cutoff mode, due to the change in torque."</p>	
<p>said processor subsystem determining whether to activate said fuel overinjection notification sensor based upon data received from said road speed sensor, said throttle position sensor and said manifold pressure sensor.</p>	<p>E.g., page 12.4, "During coasting and braking, fuel consumption can be further reduced by shutting off the fuel until the engine speed decreases to slightly higher than the set idle speed. <i>The ECU determines when fuel shutoff can occur by evaluating the throttle position, engine RPM, and vehicle speed.</i></p> <p>E.g., page 12.14, "Using the inputs of engine RPM and vehicle speed to the electronic control unit, thresholds can be established for limiting these variables with fuel</p>	<p>E.g., col. 2, lines 47 to 49, "The control unit 4 determines the number of cylinders to which fuel is injected, and controls fuel injection through a plurality of fuel injection valves 3 which are respectively positioned on the cylinders."</p> <p>E.g., col. 2, lines 51 to 54, "The determination of the number of the cylinders to which fuel is injected is performed based on signals from a throttle opening sensor 1 and a vehicle velocity sensor 2."</p>

Limitation of '781 Patent Claim 28	Automotive Electronics Handbook (Jurgen)	U.S. Patent No. 4,061,055 (Nissan '055)
	<p>cutoff. <i>When the maximum speed is achieved, the fuel injectors are shut off.</i> When the speed decreases below the threshold, fuel injection resumes.”</p> <p>E.g., pages 13.7 to 13.9, “<i>The basic functions of the transmission control are the shift point control, the lockup control, engine torque control during shifting, related safety functions, and diagnostic functions for vehicle service.</i>”</p> <p>E.g., page 13.9, “The basic shift point control uses shift maps, which are defined in data in the unit memory. These shift maps are selectable over a wide range. <i>The shift point limitations are made, on the one hand, by the highest admissible engine speed for each application and, on the other hand, by the lowest engine speed that is practical for driving comfort and noise emission. The inputs of the shift point determination are the throttle position, the accelerator pedal position, and the vehicle speed (determined by the transmission output speed).</i>”</p>	<p>E.g., col. 2, lines 59 to 66, “With this arrangement, when the signal from the vehicle velocity sensor 2 exceeds a predetermined level and at the same time the signal from the throttle opening sensor 1 falls below another predetermined level, the control unit 4 determines the number of cylinders to which fuel is actually injected based on the two signals applied and stops injection of fuel to specified one or more cylinders.”</p>

Limitation of '781 Patent Claim 29	Automotive Electronics Handbook (Jurgen)	U.S. Patent No. 4,061,055 (Nissan '055)
29. Apparatus according to claim 28 and further comprising:	See claim 28 claim chart, at page A-185.	See claim 28 claim chart, at page A-185.
a memory subsystem, coupled to said processor subsystem, said memory subsystem maintaining a manifold pressure set point;	<p>E.g., page 13.5, "The calculators inside the control units are usually microcontrollers. . . . <i>The memory devices for program and data are usually EPROMS.</i> Their storage capacity is, in present applications, up to 64 Kbytes. Future applications will necessitate storage sizes up to 128 Kbytes. The failure storages for diagnostics and the storage for adaptive data are in conventional applications, battery voltage-supplied RAMs. These are increasingly being replaced by EEPROMs."</p> <p>E.g., page 12.9, "A subsystem of the fuel control system is lambda closed-loop control. . . .</p> <p>[T]he engine control unit uses an anticipatory control strategy that uses engine load and RPM to determine the approximate fuel requirement. <i>The engine load information is provided by the manifold pressure sensor for speed density systems and by the air meter for air flow and air mass measurement systems and by the throttle valve position sensor. The engine control unit contains data tables for combinations of load and RPM.</i> This allows for rapid response to changes in operating conditions. The lambda sensor still provides the feedback correction for each load/RPM point. . . .</p> <p>[T]he electronic control unit has a feature for adapting changes in the fuel required for the load/RPM points. <i>At each load/RPM point, the lambda sensor continuously provides information that allows the system to adjust the fuel to the commanded A/F ratio. The corrected information is stored in RAM (random access memory) so that the next time the engine reaches that operating point (load/RPM), the anticipatory value will require less correction. These values remain stored in the electronic control unit even after the engine is shut off.</i> Only if power to the electronic control unit is disrupted</p>	<p>E.g., col. 2, lines 47 to 49, "The control unit 4 determines the number of cylinders to which fuel is injected, and controls fuel injection through a plurality of fuel injection valves 3 which are respectively positioned on the cylinders."</p> <p>E.g., col. 2, lines 51 to 54, "The determination of the number of the cylinders to which fuel is injected is performed based on signals from a throttle opening sensor 1 and a vehicle velocity sensor 2."</p> <p>E.g., col. 2, lines 59 to 66, "With this arrangement, when the signal from the vehicle velocity sensor 2 exceeds a predetermined level and at the same time the signal from the throttle opening sensor 1 falls below another predetermined level, the control unit 4 determines the number of cylinders to which fuel is actually injected based on the two signals applied and stops injection of fuel to specified one or more cylinders."</p>

Limitation of '781 Patent Claim 29	Automotive Electronics Handbook (Jurgen)	U.S. Patent No. 4,061,055 (Nissan '055)
	<p>(i.e., due to a dead battery), will the correction be lost. In that case, the electronic control unit will revert back to the original production values that are written in ROM (read-only memory).”</p> <p>E.g., page 14.2, “Other safety-related items include <i>program code to detect abnormal operating conditions and preserving into memory the data points associated with the abnormal condition for later diagnostics.</i> Abnormal conditions, for example, could be an intermittent vehicle speed sensor, or erratic driver switch signals.”</p> <p>E.g., pages 22.2 to 22.3, “The most important test points of control units and sensors are tied to a diagnostic connector which is plugged into the measuring instrument with a corresponding adapter for the respective vehicle. . . . <i>Modern electronics in vehicles support diagnosis by comparing the registered actual value with the internally stored nominal values</i> with the help of control units and their self-diagnosis, thus detecting faults.”</p>	
<p>said processor subsystem activating said fuel overinjection notification circuit upon determining that:</p>	<p>E.g., page 12.22, “During an acceleration transition, the ECU adds a correction factor (an increase) to the commanded injector pulse width. The sudden increase in air results in a lean mixture which must be corrected swiftly to obtain good transitional response. <i>During a deceleration transition, the fuel can be shut off by simply not providing a pulse width signal to the injector to minimize exhaust emissions and fuel consumption.</i>”</p> <p>E.g., page 12.4, “During coasting and braking, fuel consumption can be further reduced by shutting off the fuel until the engine speed decreases to slightly higher than the set idle speed. <i>The ECU determines when fuel shutoff can occur by evaluating the throttle position, engine RPM, and vehicle speed.</i>”</p>	<p>E.g., col. 2, lines 59 to 66, “With this arrangement, when the signal from the vehicle velocity sensor 2 exceeds a predetermined level and at the same time the signal from the throttle opening sensor 1 falls below another predetermined level, the control unit 4 determines the number of cylinders to which fuel is actually injected based on the two signals applied and stops injection of fuel to specified one or more cylinders.”</p>

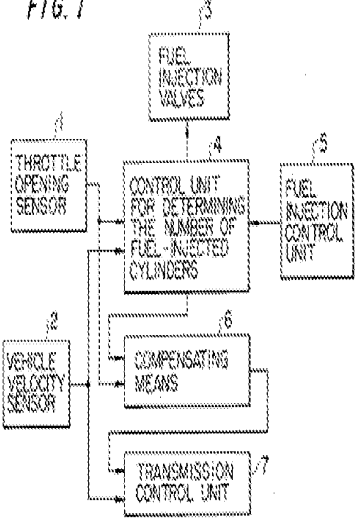

Limitation of '781 Patent Claim 29	Automotive Electronics Handbook (Jurgen)	U.S. Patent No. 4,061,055 (Nissan '055)
	<p>E.g., page 12.14, "Using the inputs of engine RPM and vehicle speed to the electronic control unit, thresholds can be established for limiting these variables with fuel cutoff. <i>When the maximum speed is achieved, the fuel injectors are shut off.</i> When the speed decreases below the threshold, fuel injection resumes."</p> <p>E.g., page 12.17, "<i>During transition to fuel cutoff, the ignition timing is retarded from its current setting to reduce engine torque and to assist in engine braking. The fuel is then shut off.</i> During the transition, the throttle bypass valve or the main throttle valve may remain open for a short period to allow fresh air to oxidize the remaining unburned HC and CO to further reduce exhaust emissions. During development of the fuel cutoff strategy, the advantage of reduced emission effects and catalyst temperature control must be balanced against driveability requirements. The use of fuel cutoff may change the perceived amount of engine braking felt by the driver. In addition, care must be taken to avoid a 'bump' feel when entering the fuel cutoff mode, due to the change in torque."</p>	
<p>(1) based upon data received from said road speed sensor, road speed of said vehicle is increasing;</p>	<p>E.g., page 7.6, "There are several applications for rotational speed sensing. First it is necessary to monitor engine speed. This information is used for transmission control, engine control, cruise control, and possibly for a tachometer. Electronics and electronic sensing in the automobile were brought about by the need for higher efficiency engines, better fuel economy, increased power and performance, and lower emissions. Second, <i>wheel speed sensing is required</i> for use in transmissions, cruise control, speedometers, antilock brake systems (ABS), traction control (ASR), variable ratio power steering assist, four-wheel steering, and possibly in inertial navigation and air bag deployment applications."</p> <p>E.g., page 7.8, "In electronic transmission applications, <i>information from the road and engine speed sensors</i>, as</p>	<p>E.g., col. 2, lines 51 to 54, "The determination of the number of the cylinders to which fuel is injected is performed based on signals from a throttle opening sensor 1 and a <i>vehicle velocity sensor 2.</i>"</p> <p>E.g., col. 2, lines 59 to 66, "With this arrangement, when the signal from the vehicle velocity sensor 2 exceeds a predetermined level and at the same time the signal from the throttle opening sensor 1 falls below another predetermined level, the control unit 4 determines the number of cylinders to which fuel is actually injected based on the two signals applied and stops injection of fuel to specified one or more cylinders."</p> <p>E.g., FIG. 1:</p>

Limitation of '781 Patent Claim 29	Automotive Electronics Handbook (Jurgen)	U.S. Patent No. 4,061,055 (Nissan '055)
	<p>well as torque data and throttle position are required for the MCU to select the optimum gear ratio.”</p>	<p><b>FIG. 1</b></p>  <p>See also Col. 1, lines 63 to 64.</p>
<p>(2) based upon data received from said throttle position sensor, throttle position for said vehicle is increasing; and</p>	<p>E.g., page 12.18, “To control the idle speed, the ECU uses inputs from the <i>throttle position sensor</i>, air conditioning, automatic transmission, power steering, charging system, engine RPM, and vehicle speed.”</p> <p>E.g., page 12.21, “The electronic injection unit also houses the <i>throttle position sensor</i> and, in some cases, an inlet air temperature sensor which provides operating condition information to the ECU.”</p>	<p>E.g., col. 2, lines 51 to 54, “The determination of the number of the cylinders to which fuel is injected is performed based on signals from a <i>throttle opening sensor 1</i> and a vehicle velocity sensor 2.”</p> <p>E.g., col. 2, lines 59 to 66, “With this arrangement, when the signal from the vehicle velocity sensor 2 exceeds a predetermined level and at the same time the signal from the throttle opening sensor 1 falls below another predetermined level, the control unit 4 determines the number of cylinders to which fuel is actually injected based on the two signals applied and stops injection of fuel to specified one or more cylinders.”</p> <p>E.g., FIG. 1:</p>

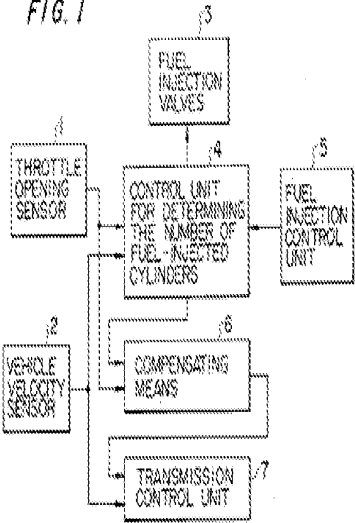
Limitation of '781 Patent Claim 29	Automotive Electronics Handbook (Jurgen)	U.S. Patent No. 4,061,055 (Nissan '055)
		<p><i>FIG. 1</i></p>  <p>See also Col. 1, lines 63 to 64.</p>
<p>(3) based upon data received from said manifold pressure sensor, manifold pressure for said vehicle exceeds said manifold pressure set point.</p>	<p>E.g., page 2.5, "Automotive specification and testing guidelines have been developed and published by the Society of Automotive Engineers (SAE) specifically for <i>manifold absolute pressure (MAP) sensors</i>."</p> <p>E.g., page 2.7, "Manifold absolute pressure (MAP) is used as an input to fuel and ignition control in internal combustion engine control systems. <i>The speed-density system that uses the MAP sensor</i> has been preferred over mass air flow (MAF) control because it's less expensive, but stricter emission standards are causing more manufacturers to use mass air flow for future models."</p>	

Limitation of '781 Patent Claim 30	Automotive Electronics Handbook (Jurgen)	U.S. Patent No. 4,061,055 (Nissan '055)
30. Apparatus according to claim 28, wherein:	See claim 28 claim chart, at page A-185.	See claim 28 claim chart, at page A-185.
said plurality of sensors coupled to said vehicle further include an engine speed sensor;	<p>E.g., page 7.6, "There are several applications for rotational speed sensing. <b>First it is necessary to monitor engine speed.</b> This information is used for transmission control, engine control, cruise control, and possibly for a tachometer. Electronics and electronic sensing in the automobile were brought about by the need for higher efficiency engines, better fuel economy, increased power and performance, and lower emissions. Second, <b>wheel speed sensing is required</b> for use in transmissions, cruise control, speedometers, antilock brake systems (ABS), traction control (ASR), variable ratio power steering assist, four-wheel steering, and possibly in inertial navigation and air bag deployment applications."</p> <p>E.g., page 7.8, "In electronic transmission applications, <b>information from the road and engine speed sensors</b>, as well as torque data and throttle position are required for the MCU to select the optimum gear ratio."</p>	
said processor subsystem activating said fuel overinjection notification circuit upon determining that:	<p>E.g., page 12.4, "During coasting and braking, fuel consumption can be further reduced by shutting off the fuel until the engine speed decreases to slightly higher than the set idle speed. <b>The ECU determines when fuel shutoff can occur by evaluating the throttle position, engine RPM, and vehicle speed.</b>"</p> <p>E.g., page 12.14, "Using the inputs of engine RPM and vehicle speed to the electronic control unit, thresholds can be established for limiting these variables with fuel cutoff. <b>When the maximum speed is achieved, the fuel injectors are shut off.</b> When the speed decreases below the threshold, fuel injection resumes."</p> <p>E.g., pages 13.7 to 13.9, "<b>The basic functions of the transmission control are the shift point control</b>, the lockup control, engine torque control during shifting, related safety functions, and diagnostic functions for</p>	<p>E.g., col. 2, lines 47 to 49, "The control unit 4 determines the number of cylinders to which fuel is injected, and controls fuel injection through a plurality of fuel injection valves 3 which are respectively positioned on the cylinders."</p> <p>E.g., col. 2, lines 51 to 54, "The determination of the number of the cylinders to which fuel is injected is performed based on signals from a throttle opening sensor 1 and a vehicle velocity sensor 2."</p> <p>E.g., col. 2, lines 59 to 66, "With this arrangement, when the signal from the vehicle velocity sensor 2 exceeds a predetermined level and at the same time the signal from the throttle opening sensor 1 falls below another predetermined level, the control unit 4 determines the number of cylinders to which fuel is actually injected based on the two signals applied and</p>

Limitation of '781 Patent Claim 30	Automotive Electronics Handbook (Jurgen)	U.S. Patent No. 4,061,055 (Nissan '055)
	<p>vehicle service.”</p> <p>E.g., page 13.9, “The basic shift point control uses shift maps, which are defined in data in the unit memory. These shift maps are selectable over a wide range. <i>The shift point limitations are made</i>, on the one hand, by the highest admissible engine speed for each application and, on the other hand, <i>by the lowest engine speed that is practical for driving comfort and noise emission. The inputs of the shift point determination are the throttle position, the accelerator pedal position, and the vehicle speed</i> (determined by the transmission output speed).”</p>	<p>stops injection of fuel to specified one or more cylinders.”</p>
<p>(1) based upon data received from said road speed sensor, road speed of said vehicle is decreasing;</p>	<p>E.g., page 7.6, “There are several applications for rotational speed sensing. First it is necessary to monitor engine speed. This information is used for transmission control, engine control, cruise control, and possibly for a tachometer. Electronics and electronic sensing in the automobile were brought about by the need for higher efficiency engines, better fuel economy, increased power and performance, and lower emissions. Second, <i>wheel speed sensing is required</i> for use in transmissions, cruise control, speedometers, antilock brake systems (ABS), traction control (ASR), variable ratio power steering assist, four-wheel steering, and possibly in inertial navigation and air bag deployment applications.”</p> <p>E.g., page 7.8, “In electronic transmission applications, <i>information from the road and engine speed sensors</i>, as well as torque data and throttle position are required for the MCU to select the optimum gear ratio.”</p>	<p>E.g., col. 2, lines 51 to 54, “The determination of the number of the cylinders to which fuel is injected is performed based on signals from a throttle opening sensor 1 and a <i>vehicle velocity sensor 2</i>.”</p> <p>E.g., col. 2, lines 59 to 66, “With this arrangement, when the signal from the vehicle velocity sensor 2 exceeds a predetermined level and at the same time the signal from the throttle opening sensor 1 falls below another predetermined level, the control unit 4 determines the number of cylinders to which fuel is actually injected based on the two signals applied and stops injection of fuel to specified one or more cylinders.”</p> <p>E.g., FIG. 1:</p>

Limitation of '781 Patent Claim 30	Automotive Electronics Handbook (Jurgen)	U.S. Patent No. 4,061,055 (Nissan '055)
		<p><i>FIG. 1</i></p> <p>See also Col. 1, lines 63 to 64.</p>
<p>(2) based upon data received from said throttle position sensor, throttle position for said vehicle is increasing;</p>	<p>E.g., page 12.18, "To control the idle speed, the ECU uses inputs from the <i>throttle position sensor</i>, air conditioning, automatic transmission, power steering, charging system, engine RPM, and vehicle speed."</p> <p>E.g., page 12.21, "The electronic injection unit also houses the <i>throttle position sensor</i> and, in some cases, an inlet air temperature sensor which provides operating condition information to the ECU."</p>	<p>E.g., col. 2, lines 51 to 54, "The determination of the number of the cylinders to which fuel is injected is performed based on signals from a <i>throttle opening sensor 1</i> and a vehicle velocity sensor 2."</p> <p>E.g., col. 2, lines 59 to 66, "With this arrangement, when the signal from the vehicle velocity sensor 2 exceeds a predetermined level and at the same time the signal from the throttle opening sensor 1 falls below another predetermined level, the control unit 4 determines the number of cylinders to which fuel is actually injected based on the two signals applied and stops injection of fuel to specified one or more cylinders."</p> <p>E.g., FIG. 1:</p>

Limitation of '781 Patent Claim 30	Automotive Electronics Handbook (Jurgen)	U.S. Patent No. 4,061,055 (Nissan '055)
		<p><i>FIG. 1</i></p> <p>See also Col. 1, lines 63 to 64.</p>
<p>(3) based upon data received from said manifold pressure sensor, manifold pressure for said vehicle is increasing; and</p>	<p>E.g., page 2.5, “Automotive specification and testing guidelines have been developed and published by the Society of Automotive Engineers (SAE) specifically for <i>manifold absolute pressure (MAP) sensors.</i>”</p> <p>E.g., page 2.7, “Manifold absolute pressure (MAP) is used as an input to fuel and ignition control in internal combustion engine control systems. <i>The speed-density system that uses the MAP sensor</i> has been preferred over mass air flow (MAF) control because it's less expensive, but stricter emission standards are causing more manufacturers to use mass air flow for future models.”</p>	
<p>(4) based upon data received from said engine speed sensor, engine speed for said vehicle is decreasing.</p>	<p>E.g., page 7.6, “There are several applications for rotational speed sensing. <i>First it is necessary to monitor engine speed.</i> This information is used for transmission control, engine control, cruise control, and possibly for a tachometer. Electronics and electronic sensing in the</p>	

Limitation of '781 Patent Claim 30	Automotive Electronics Handbook (Jurgen)	U.S. Patent No. 4,061,055 (Nissan '055)
	<p>automobile were brought about by the need for higher efficiency engines, better fuel economy, increased power and performance, and lower emissions. Second, <i>wheel speed sensing is required</i> for use in transmissions, cruise control, speedometers, antilock brake systems (ABS), traction control (ASR), variable ratio power steering assist, four-wheel steering, and possibly in inertial navigation and air bag deployment applications.”</p> <p>E.g., page 7.8, “In electronic transmission applications, <i>information from the road and engine speed sensors</i>, as well as torque data and throttle position are required for the MCU to select the optimum gear ratio.”</p>	



8. Claims 28–30 are Obvious in View of the Combination of Jurgen and Mack '324

Limitation of '781 Patent Claim 28	Automotive Electronics Handbook (Jurgen)	U.S. Patent No. 5,121,324 (Mack '324)
<p>28. Apparatus for optimizing operation of a vehicle, comprising:</p>	<p>E.g., page 12.1, “The electronic engine control system consists of sensing devices which continuously measure the operating conditions of the engine, <i>an electronic control unit (ECU) which evaluates the sensor inputs using data tables and calculations and determines the output to the actuating devices</i>, and actuating devices which are commanded by the ECU to perform an action in response to the sensor inputs.</p> <p>The motive for using an electronic engine control system is to provide the needed accuracy and adaptability in order to minimize exhaust emissions and fuel consumption, <i>provide optimal driveability for all operating conditions</i>, minimize evaporative emissions, and provide system diagnosis when malfunctions occur.”</p>	<p>E.g., Abstract, “An electronic integrated engine and vehicle management and control system includes an electronic vehicle control module and a fuel injection control module, in communication with each other, which together control the total vehicle and engine operation functions of a heavy duty vehicle. A novel fuel injection timing device is utilized with the control module to allow precise and sophisticated control of engine timing based on a number of engine and vehicle operating parameters as determined by the control modules. Functions such as engine speed control, vehicle road speed control, engine protection shutdown, fuel economy, braking control and diagnostics are performed by the system.”</p>
<p>a plurality of sensors coupled to a vehicle having an engine, said plurality of sensors, which collectively monitor operation of said vehicle, including a road speed sensor, a manifold pressure sensor and a throttle position sensor;</p>	<p>E.g., page 7.6, “There are several applications for rotational speed sensing. <i>First it is necessary to monitor engine speed</i>. This information is used for transmission control, engine control, cruise control, and possibly for a tachometer. Electronics and electronic sensing in the automobile were brought about by the need for higher efficiency engines, better fuel economy, increased power and performance, and lower emissions. Second, <i>wheel speed sensing is required</i> for use in transmissions, cruise control, speedometers, antilock brake systems (ABS), traction control (ASR), variable ratio power steering assist, four-wheel steering, and possibly in inertial navigation and air bag deployment applications.”</p> <p>E.g., page 7.8, “In electronic transmission applications, <i>information from the road and engine speed sensors</i>, as well as torque data and throttle position are required for the MCU to select the optimum gear ratio.”</p> <p>E.g., page 2.5, “Automotive specification and testing guidelines have been developed and published by the</p>	<p>E.g., col. 3, lines 57 to 61, “The control module 200 reads input signals from an accelerator pedal position sensor 2004, an engine speed sensor 2005, a coolant temperature sensor 2006, a fuel rack position sensor 2007, and a torque limiter switch 2008.”</p> <p>E.g., col. 5, lines 23 to 41, “The control module 100 monitors vehicle road speed and engine speed in conjunction with information from various switches indicating application of brakes, clutch, and switches mounted on the instrument panel, to maintain vehicle operation within specified limits. These limits, such as minimum and maximum engine speeds and maximum vehicle road speed can be programmed into the control module memory via the SAE serial data communication link from an external computer such as a PC, which can be interfaced with the control module through a serial port connector attached to the data communication link 10. If the control module determines that any modifications are needed to maintain vehicle and engine operation within the prescribed limits, the fuel quantity</p>

Limitation of '781 Patent Claim 28	Automotive Electronics Handbook (Jurgen)	U.S. Patent No. 5,121,324 (Mack '324)
	<p>Society of Automotive Engineers (SAE) specifically for <i>manifold absolute pressure (MAP) sensors</i>.”</p> <p>E.g., page 2.7, “Manifold absolute pressure (MAP) is used as an input to fuel and ignition control in internal combustion engine control systems. <i>The speed-density system that uses the MAP sensor</i> has been preferred over mass air flow (MAF) control because it's less expensive, but stricter emission standards are causing more manufacturers to use mass air flow for future models.”</p> <p>E.g., page 12.18, “To control the idle speed, the ECU uses inputs from the <i>throttle position sensor</i>, air conditioning, automatic transmission, power steering, charging system, engine RPM, and vehicle speed.”</p> <p>E.g., page 12.21, “The electronic injection unit also houses the <i>throttle position sensor</i> and, in some cases, an inlet air temperature sensor which provides operating condition information to the ECU.”</p>	<p>required to maintain the desired operating parameters is calculated and its value is transmitted as a fuel request signal 111 to the fuel injection control module, with a confirming signal being sent via the SAE data communication link 10.”</p> <p>E.g., FIGS. 1, 2</p>
<p>a processor subsystem, coupled to each one of said plurality of sensors, to receive data therefrom;</p>	<p>E.g., page 12.1, “The electronic engine control system consists of <i>sensing devices which continuously measure the operating conditions of the engine, an electronic control unit (ECU) which evaluates the sensor inputs</i> using data tables and calculations and determines the output to the actuating devices, and actuating devices which are commanded by the ECU to perform an action in response to the sensor inputs.”</p> <p>E.g., page 22.6, “During the entire operating time of the vehicle, <i>the ECUs are constantly supervising the sensors they are connected to</i>.”</p> <p>E.g., page 13.4, “On the functional side, the hardware configuration can be divided into power supply, input signal transfer circuits, output stages, and <i>microcontroller</i>, including peripheral components and</p>	<p>E.g., col. 2, line 45 to col. 3, line 11, “The vehicle management and control module 100 is composed of a microprocessor 1001, a random access memory 1005, and an EPROM 1003, and an EEPROM 1004. The inputs to the microprocessor 1001 comprise a number of pulse width modulated (PWM) inputs 1007, a plurality of digital data inputs 1009, and a plurality of analog inputs 1011. The pulse inputs include a pulse signal from an mph sensor which is mounted near the vehicle's transmission output shaft so as to provide an electrical pulse each time one of the teeth of a tone wheel mounted on the transmission output shaft passes the tip of the sensor. The frequency of the mph sensor output pulses is proportional to the rotational velocity of the transmission output shaft. The road speed of the vehicle can thus be calculated by factoring the number of teeth on the tone wheel, the gear ratio between the transmission output</p>

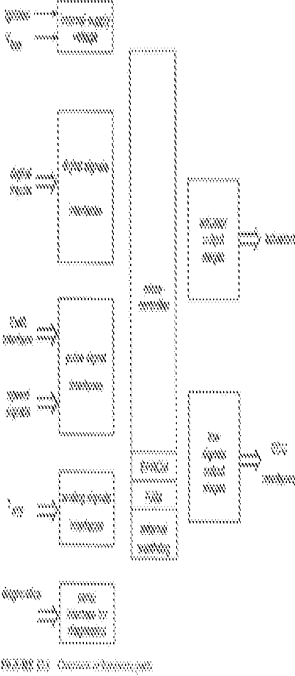
Limitation of '781 Patent Claim 28	Automotive Electronics Handbook (Jurgen)	U.S. Patent No. 5,121,324 (Mack '324)
	<p>monitoring and safety circuits (Fig. 13.1.)”</p> <p>E.g., Figure 13.1:</p>  <p>E.g., page 14.3, “The speed sensor is one of the most critical parts in the system, because the <i>microcontroller calculates the vehicle speed from the speed sensor’s signal</i> to within 1/32 m/h.”</p>	<p>shaft and the vehicle axle shaft, and the rolling circumference of the drive axle tires. These data values can be programmed into the module memory for each specific type of vehicle in which the system is installed. The timing event sensor is mounted proximate the fuel injection pump camshaft of the vehicle engine and generates a pulse when the fuel injection pump camshaft attains an angular position corresponding to port closure or beginning of fuel injection for a predetermined plunger of the injection pump. The engine position sensor is mounted proximate the engine crankshaft and generates a pulse when the crankshaft attains an angular position related to top dead center (TDC) of the corresponding piston of the cylinder to which the plunger is coupled, on its power stroke. The data line 20 is a pulse width modulation signal line which communicates engine speed and fuel quantity data to the microprocessor 1001 from the fuel injection control module 200.”</p> <p>E.g., FIGS. 1, 2</p>
<p>a fuel overinjection notification circuit coupled to said processor subsystem, said fuel overinjection notification circuit issuing a notification that excessive fuel is being supplied to said engine of said vehicle;</p>	<p>E.g., page 12.22, “During an acceleration transition, the ECU adds a correction factor (an increase) to the commanded injector pulse width. The sudden increase in air results in a lean mixture which must be corrected swiftly to obtain good transitional response. <i>During a deceleration transition, the fuel can be shut off by simply not providing a pulse width signal to the injector to minimize exhaust emissions and fuel consumption.</i>”</p> <p>E.g., page 12.4, “During coasting and braking, fuel</p>	<p>E.g., col. 6, lines 24 to 53, “In the case where the control module detects a vehicle road speed above the preset road speed limit, the module generates a fuel request signal which causes the fuel injection control module to stop fueling the engine to insure that the vehicle operator would not be able to exceed the stored limit. It is possible, however, for a loaded vehicle to exceed the stored road speed limit while going down hill. In such a case, the control module would transmit a fuel quantity request signal of zero to disable any additional increase</p>

Limitation of '781 Patent Claim 28	Automotive Electronics Handbook (Jurgen)	U.S. Patent No. 5,121,324 (Mack '324)
	<p>consumption can be further reduced by shutting off the fuel until the engine speed decreases to slightly higher than the set idle speed. <i>The ECU determines when fuel shutoff can occur by evaluating the throttle position, engine RPM, and vehicle speed.</i></p> <p>E.g., page 12.14, "Using the inputs of engine RPM and vehicle speed to the electronic control unit, thresholds can be established for limiting these variables with fuel cutoff. <i>When the maximum speed is achieved, the fuel injectors are shut off.</i> When the speed decreases below the threshold, fuel injection resumes."</p> <p>E.g., page 12.17, "<i>During transition to fuel cutoff, the ignition timing is retarded from its current setting to reduce engine torque and to assist in engine braking. The fuel is then shut off.</i> During the transition, the throttle bypass valve or the main throttle valve may remain open for a short period to allow fresh air to oxidize the remaining unburned HC and CO to further reduce exhaust emissions. During development of the fuel cutoff strategy, the advantage of reduced emission effects and catalyst temperature control must be balanced against driveability requirements. The use of fuel cutoff may change the perceived amount of engine braking felt by the driver. In addition, care must be taken to avoid a 'bump' feel when entering the fuel cutoff mode, due to the change in torque."</p>	<p>in vehicle speed. If the vehicle transmission should jump out of gear and into neutral at such time, the operator will not be able to fuel the engine to increase engine speed sufficiently to place the transmission back into gear. To eliminate such an occurrence, the control module detects a ratio of engine speed to vehicle road speed and compares this calculated ratio with a prestored minimum engine speed to road speed ratio. FIG. 8 is a flow chart explaining this operation. The minimum stored ratio is determined based on the minimum possible engine rotational speed at the road speed limit. As long as the actual vehicle speed is above the stored road speed limit and the transmission is in gear, the engine speed-to-vehicle speed ratio will be above the stored minimum. However, if the engine speed-to-vehicle speed ratio is below such minimum, the transmission must be out of gear. Upon the occurrence of such a condition, the road speed limiting function will be disabled for a specified period of time to allow the operator to rev up the engine and place the transmission back into gear."</p>
<p>said processor subsystem determining whether to activate said fuel overinjection notification sensor based upon data received from said road speed sensor, said throttle position sensor and said manifold pressure sensor.</p>	<p>E.g., page 12.4, "During coasting and braking, fuel consumption can be further reduced by shutting off the fuel until the engine speed decreases to slightly higher than the set idle speed. <i>The ECU determines when fuel shutoff can occur by evaluating the throttle position, engine RPM, and vehicle speed.</i></p> <p>E.g., page 12.14, "Using the inputs of engine RPM and vehicle speed to the electronic control unit, thresholds can be established for limiting these variables with fuel</p>	<p>E.g., col. 6, lines 24 to 53, "In the case where the control module detects a vehicle road speed above the preset road speed limit, the module generates a fuel request signal which causes the fuel injection control module to stop fueling the engine to insure that the vehicle operator would not be able to exceed the stored limit. It is possible, however, for a loaded vehicle to exceed the stored road speed limit while going down hill. In such a case, the control module would transmit a fuel quantity request signal of zero to disable any additional increase</p>

Limitation of '781 Patent Claim 28	Automotive Electronics Handbook (Jurgen)	U.S. Patent No. 5,121,324 (Mack '324)
	<p>cutoff. <i>When the maximum speed is achieved, the fuel injectors are shut off.</i> When the speed decreases below the threshold, fuel injection resumes.”</p> <p>E.g., pages 13.7 to 13.9, “<i>The basic functions of the transmission control are the shift point control, the lockup control, engine torque control during shifting, related safety functions, and diagnostic functions for vehicle service.</i>”</p> <p>E.g., page 13.9, “The basic shift point control uses shift maps, which are defined in data in the unit memory. These shift maps are selectable over a wide range. <i>The shift point limitations are made, on the one hand, by the highest admissible engine speed for each application and, on the other hand, by the lowest engine speed that is practical for driving comfort and noise emission. The inputs of the shift point determination are the throttle position, the accelerator pedal position, and the vehicle speed (determined by the transmission output speed).</i>”</p>	<p>in vehicle speed. If the vehicle transmission should jump out of gear and into neutral at such time, the operator will not be able to fuel the engine to increase engine speed sufficiently to place the transmission back into gear. To eliminate such an occurrence, the control module detects a ratio of engine speed to vehicle road speed and compares this calculated ratio with a prestored minimum engine speed to road speed ratio. FIG. 8 is a flow chart explaining this operation. The minimum stored ratio is determined based on the minimum possible engine rotational speed at the road speed limit. As long as the actual vehicle speed is above the stored road speed limit and the transmission is in gear, the engine speed-to-vehicle speed ratio will be above the stored minimum. However, if the engine speed-to-vehicle speed ratio is below such minimum, the transmission must be out of gear. Upon the occurrence of such a condition, the road speed limiting function will be disabled for a specified period of time to allow the operator to rev up the engine and place the transmission back into gear.”</p> <p>E.g., FIG. 2</p>

Limitation of '781 Patent Claim 29	Automotive Electronics Handbook (Jurgen)	U.S. Patent No. 5,121,324 (Mack '324)
29. Apparatus according to claim 28 and further comprising:	See claim 28 claim chart, at page A-200.	See claim 28 claim chart, at page A-200.
a memory subsystem, coupled to said processor subsystem, said memory subsystem maintaining a manifold pressure set point;	<p>E.g., page 13.5, "The calculators inside the control units are usually microcontrollers. . . . <b>The memory devices for program and data are usually EPROMS.</b> Their storage capacity is, in present applications, up to 64 Kbytes. Future applications will necessitate storage sizes up to 128 Kbytes. The failure storages for diagnostics and the storage for adaptive data are in conventional applications, battery voltage-supplied RAMs. These are increasingly being replaced by EEPROMs."</p> <p>E.g., page 12.9, "A subsystem of the fuel control system is lambda closed-loop control. . . .</p> <p>[T]he engine control unit uses an anticipatory control strategy that uses engine load and RPM to determine the approximate fuel requirement. <b>The engine load information is provided by the manifold pressure sensor for speed density systems and by the air meter for air flow and air mass measurement systems and by the throttle valve position sensor. The engine control unit contains data tables for combinations of load and RPM.</b> This allows for rapid response to changes in operating conditions. The lambda sensor still provides the feedback correction for each load/RPM point. . . .</p> <p>[T]he electronic control unit has a feature for adapting changes in the fuel required for the load/RPM points. <b>At each load/RPM point, the lambda sensor continuously provides information that allows the system to adjust the fuel to the commanded A/F ratio. The corrected information is stored in RAM (random access memory) so that the next time the engine reaches that operating point (load/RPM), the anticipatory value will require less correction. These values remain stored in the electronic control unit even after the engine is shut off.</b> Only if power to the electronic control unit is disrupted (i.e., due to a dead battery), will the correction be lost. In that case, the electronic control unit will revert back to the original production values that are written in ROM (read-only memory)."</p> <p>E.g., page 14.2, "Other safety-related items include <b>program code to</b></p>	<p>E.g., col. 2, line 45 to col. 3, line 11, "The vehicle management and control module 100 is composed of a microprocessor 1001, a random access memory 1005, and an EPROM 1003, and an EEPROM 1004. The inputs to the microprocessor 1001 comprise a number of pulse width modulated (PWM) inputs 1007, a plurality of digital data inputs 1009, and a plurality of analog inputs 1011. The pulse inputs include a pulse signal from an mph sensor which is mounted near the vehicle's transmission output shaft so as to provide an electrical pulse each time one of the teeth of a tone wheel mounted on the transmission output shaft passes the tip of the sensor. The frequency of the mph sensor output pulses is proportional to the rotational velocity of the transmission output shaft. The road speed of the vehicle can thus be calculated by factoring the number of teeth on the tone wheel, the gear ratio between the transmission output shaft and the vehicle axle shaft, and the rolling circumference of the drive axle tires. These data values can be programmed into the module memory for each specific type of vehicle in which the system is installed. The timing event sensor is mounted proximate the fuel injection pump camshaft of the vehicle engine and generates a pulse when the fuel injection pump camshaft attains an angular position corresponding to port closure or beginning of fuel injection for a predetermined plunger of the injection pump. The engine position sensor is mounted proximate the engine crankshaft and generates a pulse when the crankshaft attains an angular position related to top dead center (TDC) of the corresponding piston of the cylinder to which the plunger is coupled, on its power stroke. The data line 20 is a pulse width modulation signal line which communicates engine speed and fuel quantity data to the microprocessor 1001 from the fuel injection control module 200."</p>

Limitation of '781 Patent Claim 29	Automotive Electronics Handbook (Jurgen)	U.S. Patent No. 5,121,324 (Mack '324)
	<p><i>detect abnormal operating conditions and preserving into memory the data points associated with the abnormal condition for later diagnostics.</i> Abnormal conditions, for example, could be an intermittent vehicle speed sensor, or erratic driver switch signals.”</p> <p>E.g., pages 22.2 to 22.3, “The most important test points of control units and sensors are tied to a diagnostic connector which is plugged into the measuring instrument with a corresponding adapter for the respective vehicle. . . .</p> <p><i>Modern electronics in vehicles support diagnosis by comparing the registered actual value with the internally stored nominal values</i> with the help of control units and their self-diagnosis, thus detecting faults.”</p>	<p>E.g., FIGS. 1, 2</p>
<p>said processor subsystem activating said fuel overinjection notification circuit upon determining that:</p>	<p>E.g., page 12.22, “During an acceleration transition, the ECU adds a correction factor (an increase) to the commanded injector pulse width. The sudden increase in air results in a lean mixture which must be corrected swiftly to obtain good transitional response. <i>During a deceleration transition, the fuel can be shut off by simply not providing a pulse width signal to the injector to minimize exhaust emissions and fuel consumption.</i>”</p> <p>E.g., page 12.4, “During coasting and braking, fuel consumption can be further reduced by shutting off the fuel until the engine speed decreases to slightly higher than the set idle speed. <i>The ECU determines when fuel shutoff can occur by evaluating the throttle position, engine RPM, and vehicle speed.</i>”</p> <p>E.g., page 12.14, “Using the inputs of engine RPM and vehicle speed to the electronic control unit, thresholds can be established for limiting these variables with fuel cutoff. <i>When the maximum speed is achieved, the fuel injectors are shut off.</i> When the speed decreases below the threshold, fuel injection resumes.”</p> <p>E.g., page 12.17, “<i>During transition to fuel cutoff, the ignition timing is retarded from its current setting to reduce engine torque and to assist in engine braking. The fuel is then shut off.</i> During the transition, the throttle bypass valve or the main throttle valve may remain open for a short period to allow fresh air to oxidize the</p>	<p>E.g., col. 6, lines 24 to 53, “In the case where the control module detects a vehicle road speed above the preset road speed limit, the module generates a fuel request signal which causes the fuel injection control module to stop fueling the engine to insure that the vehicle operator would not be able to exceed the stored limit. It is possible, however, for a loaded vehicle to exceed the stored road speed limit while going down hill. In such a case, the control module would transmit a fuel quantity request signal of zero to disable any additional increase in vehicle speed. If the vehicle transmission should jump out of gear and into neutral at such time, the operator will not be able to fuel the engine to increase engine speed sufficiently to place the transmission back into gear. To eliminate such an occurrence, the control module detects a ratio of engine speed to vehicle road speed and compares this calculated ratio with a prestored minimum engine speed to road speed ratio. FIG. 8 is a flow chart explaining this operation. The minimum stored ratio is determined based on the minimum possible engine rotational speed at the road speed limit. As long as the actual vehicle speed is above the stored road speed limit and the transmission is in gear, the engine speed-to-vehicle speed ratio will be above the stored minimum. However, if the engine</p>

Limitation of '781 Patent Claim 29	Automotive Electronics Handbook (Jurgen)	U.S. Patent No. 5,121,324 (Mack '324)
	<p>remaining unburned HC and CO to further reduce exhaust emissions. During development of the fuel cutoff strategy, the advantage of reduced emission effects and catalyst temperature control must be balanced against driveability requirements. The use of fuel cutoff may change the perceived amount of engine braking felt by the driver. In addition, care must be taken to avoid a 'bump' feel when entering the fuel cutoff mode, due to the change in torque."</p>	<p>speed-to-vehicle speed ratio is below such minimum, the transmission must be out of gear. Upon the occurrence of such a condition, the road speed limiting function will be disabled for a specified period of time to allow the operator to rev up the engine and place the transmission back into gear."</p>
<p>(1) based upon data received from said road speed sensor, road speed of said vehicle is increasing;</p>	<p>E.g., page 7.6, "There are several applications for rotational speed sensing. First it is necessary to monitor engine speed. This information is used for transmission control, engine control, cruise control, and possibly for a tachometer. Electronics and electronic sensing in the automobile were brought about by the need for higher efficiency engines, better fuel economy, increased power and performance, and lower emissions. Second, <i>wheel speed sensing is required</i> for use in transmissions, cruise control, speedometers, antilock brake systems (ABS), traction control (ASR), variable ratio power steering assist, four-wheel steering, and possibly in inertial navigation and air bag deployment applications."</p> <p>E.g., page 7.8, "In electronic transmission applications, <i>information from the road and engine speed sensors</i>, as well as torque data and throttle position are required for the MCU to select the optimum gear ratio."</p>	<p>E.g., col. 6, lines 24 to 53, "In the case where the control module detects a <i>vehicle road speed above the preset road speed limit</i>, the module generates a fuel request signal which causes the fuel injection control module to stop fueling the engine to insure that the vehicle operator would not be able to exceed the stored limit. It is possible, however, for a loaded vehicle to exceed the stored road speed limit while going down hill. In such a case, the control module would transmit a fuel quantity request signal of zero to disable any additional increase in vehicle speed. If the vehicle transmission should jump out of gear and into neutral at such time, the operator will not be able to fuel the engine to increase engine speed sufficiently to place the transmission back into gear. To eliminate such an occurrence, the control module detects a ratio of engine speed to vehicle road speed and compares this calculated ratio with a prestored minimum engine speed to road speed ratio. FIG. 8 is a flow chart explaining this operation. The minimum stored ratio is determined based on the minimum possible engine rotational speed at the road speed limit. As long as the actual vehicle speed is above the stored road speed limit and the transmission is in gear, the engine speed-to-vehicle speed ratio will be above the stored minimum. However, if the engine speed-to-vehicle speed ratio is below such minimum, the transmission must be out of gear. Upon the occurrence of such a condition, the road speed limiting function will be disabled for a specified period of time to allow the operator to rev up the engine and place the transmission back into gear."</p>



Limitation of '781 Patent Claim 29	Automotive Electronics Handbook (Jurgen)	U.S. Patent No. 5,121,324 (Mack '324)
(2) based upon data received from said throttle position sensor, throttle position for said vehicle is increasing; and	<p>E.g., page 12.18, "To control the idle speed, the ECU uses inputs from the <i>throttle position sensor</i>, air conditioning, automatic transmission, power steering, charging system, engine RPM, and vehicle speed."</p> <p>E.g., page 12.21, "The electronic injection unit also houses the <i>throttle position sensor</i> and, in some cases, an inlet air temperature sensor which provides operating condition information to the ECU."</p>	
(3) based upon data received from said manifold pressure sensor, manifold pressure for said vehicle exceeds said manifold pressure set point.	<p>E.g., page 2.5, "Automotive specification and testing guidelines have been developed and published by the Society of Automotive Engineers (SAE) specifically for <i>manifold absolute pressure (MAP) sensors</i>."</p> <p>E.g., page 2.7, "Manifold absolute pressure (MAP) is used as an input to fuel and ignition control in internal combustion engine control systems. <i>The speed-density system that uses the MAP sensor</i> has been preferred over mass air flow (MAF) control because it's less expensive, but stricter emission standards are causing more manufacturers to use mass air flow for future models."</p>	

Limitation of '781 Patent Claim 30	Automotive Electronics Handbook (Jurgen)	U.S. Patent No. 5,121,324 (Mack '324)
30. Apparatus according to claim 28, wherein:	See claim 28 claim chart, at page A-200.	See claim 28 claim chart, at page A-200.
said plurality of sensors coupled to said vehicle further include an engine speed sensor;	<p>E.g., page 7.6, "There are several applications for rotational speed sensing. <b>First it is necessary to monitor engine speed.</b> This information is used for transmission control, engine control, cruise control, and possibly for a tachometer. Electronics and electronic sensing in the automobile were brought about by the need for higher efficiency engines, better fuel economy, increased power and performance, and lower emissions. Second, <b>wheel speed sensing is required</b> for use in transmissions, cruise control, speedometers, antilock brake systems (ABS), traction control (ASR), variable ratio power steering assist, four-wheel steering, and possibly in inertial navigation and air bag deployment applications."</p> <p>E.g., page 7.8, "In electronic transmission applications, <b>information from the road and engine speed sensors</b>, as well as torque data and throttle position are required for the MCU to select the optimum gear ratio."</p>	<p>E.g., col. 3, lines 57 to 61, "The control module 200 reads input signals from an accelerator pedal position sensor 2004, <b>an engine speed sensor 2005</b>, a coolant temperature sensor 2006, a fuel rack position sensor 2007, and a torque limiter switch 2008."</p> <p>E.g., col. 5, lines 23 to 41, "<b>The control module 100 monitors vehicle</b> road speed and <b>engine speed</b> in conjunction with information from various switches indicating application of brakes, clutch, and switches mounted on the instrument panel, to maintain vehicle operation within specified limits. These limits, such as minimum and maximum engine speeds and maximum vehicle road speed can be programmed into the control module memory via the SAE serial data communication link from an external computer such as a PC, which can be interfaced with the control module through a serial port connector attached to the data communication link 10. If the control module determines that any modifications are needed to maintain vehicle and engine operation within the prescribed limits, the fuel quantity required to maintain the desired operating parameters is calculated and its value is transmitted as a fuel request signal 111 to the fuel injection control module, with a confirming signal being sent via the SAE data communication link 10."</p> <p>E.g., FIGS. 1, 2</p>
said processor subsystem activating said fuel overinjection notification circuit upon determining that:	<p>E.g., page 12.4, "During coasting and braking, fuel consumption can be further reduced by shutting off the fuel until the engine speed decreases to slightly higher than the set idle speed. <b>The ECU determines when fuel shutoff can occur by evaluating the throttle position, engine RPM, and vehicle speed.</b>"</p> <p>E.g., page 12.14, "Using the inputs of engine RPM and</p>	

Limitation of '781 Patent Claim 30	Automotive Electronics Handbook (Jurgen)	U.S. Patent No. 5,121,324 (Mack '324)
	<p>vehicle speed to the electronic control unit, thresholds can be established for limiting these variables with fuel cutoff. <i>When the maximum speed is achieved, the fuel injectors are shut off.</i> When the speed decreases below the threshold, fuel injection resumes.”</p> <p>E.g., pages 13.7 to 13.9, “<i>The basic functions of the transmission control are the shift point control, the lockup control, engine torque control during shifting, related safety functions, and diagnostic functions for vehicle service.</i>”</p> <p>E.g., page 13.9, “The basic shift point control uses shift maps, which are defined in data in the unit memory. These shift maps are selectable over a wide range. <i>The shift point limitations are made,</i> on the one hand, by the highest admissible engine speed for each application and, on the other hand, <i>by the lowest engine speed that is practical for driving comfort and noise emission. The inputs of the shift point determination are the throttle position, the accelerator pedal position, and the vehicle speed</i> (determined by the transmission output speed).”</p>	
<p>(1) based upon data received from said road speed sensor, road speed of said vehicle is decreasing;</p>	<p>E.g., page 7.6, “There are several applications for rotational speed sensing. First it is necessary to monitor engine speed. This information is used for transmission control, engine control, cruise control, and possibly for a tachometer. Electronics and electronic sensing in the automobile were brought about by the need for higher efficiency engines, better fuel economy, increased power and performance, and lower emissions. Second, <i>wheel speed sensing is required</i> for use in transmissions, cruise control, speedometers, antilock brake systems (ABS), traction control (ASR), variable ratio power steering assist, four-wheel steering, and possibly in inertial navigation and air bag deployment applications.”</p> <p>E.g., page 7.8, “In electronic transmission applications, <i>information from the road and engine speed sensors, as</i></p>	<p>E.g., col. 6, lines 24 to 53, “In the case where the control module detects a <i>vehicle road speed above the preset road speed limit</i>, the module generates a fuel request signal which causes the fuel injection control module to stop fueling the engine to insure that the vehicle operator would not be able to exceed the stored limit. It is possible, however, for a loaded vehicle to exceed the stored road speed limit while going down hill. In such a case, the control module would transmit a fuel quantity request signal of zero to disable any additional increase in vehicle speed. If the vehicle transmission should jump out of gear and into neutral at such time, the operator will not be able to fuel the engine to increase engine speed sufficiently to place the transmission back into gear. To eliminate such an occurrence, the control module detects a ratio of engine</p>

Limitation of '781 Patent Claim 30	Automotive Electronics Handbook (Jurgen)	U.S. Patent No. 5,121,324 (Mack '324)
	<p>well as torque data and throttle position are required for the MCU to select the optimum gear ratio.”</p>	<p>speed to vehicle road speed and compares this calculated ratio with a prestored minimum engine speed to road speed ratio. FIG. 8 is a flow chart explaining this operation. The minimum stored ratio is determined based on the minimum possible engine rotational speed at the road speed limit. As long as the actual vehicle speed is above the stored road speed limit and the transmission is in gear, the engine speed-to-vehicle speed ratio will be above the stored minimum. However, if the engine speed-to-vehicle speed ratio is below such minimum, the transmission must be out of gear. Upon the occurrence of such a condition, the road speed limiting function will be disabled for a specified period of time to allow the operator to rev up the engine and place the transmission back into gear.”</p>
<p>(2) based upon data received from said throttle position sensor, throttle position for said vehicle is increasing;</p>	<p>E.g., page 12.18, “To control the idle speed, the ECU uses inputs from the <i>throttle position sensor</i>, air conditioning, automatic transmission, power steering, charging system, engine RPM, and vehicle speed.”</p> <p>E.g., page 12.21, “The electronic injection unit also houses the <i>throttle position sensor</i> and, in some cases, an inlet air temperature sensor which provides operating condition information to the ECU.”</p>	
<p>(3) based upon data received from said manifold pressure sensor, manifold pressure for said vehicle is increasing; and</p>	<p>E.g., page 2.5, “Automotive specification and testing guidelines have been developed and published by the Society of Automotive Engineers (SAE) specifically for <i>manifold absolute pressure (MAP) sensors</i>.”</p> <p>E.g., page 2.7, “Manifold absolute pressure (MAP) is used as an input to fuel and ignition control in internal combustion engine control systems. <i>The speed-density system that uses the MAP sensor</i> has been preferred over mass air flow (MAF) control because it's less expensive, but stricter emission standards are causing more manufacturers to use mass air flow for future models.”</p>	

Limitation of '781 Patent Claim 30	Automotive Electronics Handbook (Jurgen)	U.S. Patent No. 5,121,324 (Mack '324)
<p>(4) based upon data received from said engine speed sensor, engine speed for said vehicle is decreasing.</p>	<p>E.g., page 7.6, "There are several applications for rotational speed sensing. <i>First it is necessary to monitor engine speed.</i> This information is used for transmission control, engine control, cruise control, and possibly for a tachometer. Electronics and electronic sensing in the automobile were brought about by the need for higher efficiency engines, better fuel economy, increased power and performance, and lower emissions. Second, <i>wheel speed sensing is required</i> for use in transmissions, cruise control, speedometers, antilock brake systems (ABS), traction control (ASR), variable ratio power steering assist, four-wheel steering, and possibly in inertial navigation and air bag deployment applications."</p> <p>E.g., page 7.8, "In electronic transmission applications, <i>information from the road and engine speed sensors</i>, as well as torque data and throttle position are required for the MCU to select the optimum gear ratio."</p>	<p>E.g., col. 6, lines 24 to 53, "In the case where the control module detects a vehicle road speed above the preset road speed limit, the module generates a fuel request signal which causes the fuel injection control module to stop fueling the engine to insure that the vehicle operator would not be able to exceed the stored limit. It is possible, however, for a loaded vehicle to exceed the stored road speed limit while going down hill. In such a case, the control module would transmit a fuel quantity request signal of zero to disable any additional increase in vehicle speed. If the vehicle transmission should jump out of gear and into neutral at such time, the operator will not be able to fuel the engine to increase engine speed sufficiently to place the transmission back into gear. <i>To eliminate such an occurrence, the control module detects a ratio of engine speed to vehicle road speed and compares this calculated ratio with a prestored minimum engine speed to road speed ratio.</i> FIG. 8 is a flow chart explaining this operation. The minimum stored ratio is determined based on the minimum possible engine rotational speed at the road speed limit. As long as the actual vehicle speed is above the stored road speed limit and the transmission is in gear, the engine speed-to-vehicle speed ratio will be above the stored minimum. However, if the engine speed-to-vehicle speed ratio is below such minimum, the transmission must be out of gear. Upon the occurrence of such a condition, <i>the road speed limiting function will be disabled for a specified period of time to allow the operator to rev up the engine and place the transmission back into gear.</i>"</p>

9. Claims 28–30 are Obvious in View of the Combination of Jurgen and GM ’753

Limitation of ’781 Patent Claim 28	Automotive Electronics Handbook (Jurgen)	U.S. Patent No. 3,925,753 (GM ’753)
<p>28. Apparatus for optimizing operation of a vehicle, comprising:</p>	<p>E.g., page 12.1, “The electronic engine control system consists of sensing devices which continuously measure the operating conditions of the engine, <i>an electronic control unit (ECU) which evaluates the sensor inputs using data tables and calculations and determines the output to the actuating devices</i>, and actuating devices which are commanded by the ECU to perform an action in response to the sensor inputs.</p> <p>The motive for using an electronic engine control system is to provide the needed accuracy and adaptability in order to minimize exhaust emissions and fuel consumption, <i>provide optimal driveability for all operating conditions</i>, minimize evaporative emissions, and provide system diagnosis when malfunctions occur.”</p>	<p>E.g., Abstract, “A warning system for providing an indication when the fuel consumption of a throttle controlled vehicle having an internal combustion engine with an intake manifold exceeds pre-established levels.”</p>
<p>a plurality of sensors coupled to a vehicle having an engine, said plurality of sensors, which collectively monitor operation of said vehicle, including a road speed sensor, a manifold pressure sensor and a throttle position sensor;</p>	<p>E.g., page 7.6, “There are several applications for rotational speed sensing. <i>First it is necessary to monitor engine speed</i>. This information is used for transmission control, engine control, cruise control, and possibly for a tachometer. Electronics and electronic sensing in the automobile were brought about by the need for higher efficiency engines, better fuel economy, increased power and performance, and lower emissions. Second, <i>wheel speed sensing is required</i> for use in transmissions, cruise control, speedometers, antilock brake systems (ABS), traction control (ASR), variable ratio power steering assist, four-wheel steering, and possibly in inertial navigation and air bag deployment applications.”</p> <p>E.g., page 7.8, “In electronic transmission applications, <i>information from the road and engine speed sensors</i>, as well as torque data and throttle position are required for the MCU to select the optimum gear ratio.”</p> <p>E.g., page 2.5, “Automotive specification and testing guidelines have been developed and published by the</p>	<p>E.g., col. 1, lines 38 to 55, “Referring to the drawing, there is illustrated a warning device for providing an indication of excessive fuel consumption by a vehicle powered by a throttle controlled internal combustion engine having an intake manifold. A conduit pneumatically couples the intake manifold vacuum to a vacuum transducer 12. The vacuum transducer 12 is effective to generate a voltage having a magnitude which progressively changes with a progressively increased intake manifold vacuum level. In the preferred embodiment, the magnitude of the voltage generated by the vacuum transducer 12 progressively decreases with an increasing intake manifold vacuum level. The voltage generated by the vacuum transducer 12 is coupled to the positive input of a summing switch 14 through a resistor 15. The resulting current supplied by the vacuum transducer 12, hereinafter referred to as the vacuum signal, progressively decreases with increasing intake manifold vacuum level.”</p> <p>E.g., col. 2, lines 34 to 51, “To provide a manifold</p>

Limitation of '781 Patent Claim 28	Automotive Electronics Handbook (Jurgen)	U.S. Patent No. 3,925,753 (GM '753)
	<p>Society of Automotive Engineers (SAE) specifically for <i>manifold absolute pressure (MAP) sensors</i>.”</p> <p>E.g., page 2.7, “Manifold absolute pressure (MAP) is used as an input to fuel and ignition control in internal combustion engine control systems. <i>The speed-density system that uses the MAP sensor</i> has been preferred over mass air flow (MAF) control because it's less expensive, but stricter emission standards are causing more manufacturers to use mass air flow for future models.”</p> <p>E.g., page 12.18, “To control the idle speed, the ECU uses inputs from the <i>throttle position sensor</i>, air conditioning, automatic transmission, power steering, charging system, engine RPM, and vehicle speed.”</p> <p>E.g., page 12.21, “The electronic injection unit also houses the <i>throttle position sensor</i> and, in some cases, an inlet air temperature sensor which provides operating condition information to the ECU.”</p>	<p>vacuum trigger level which increases with increasing vehicle speed, a speed transducer 32 is provided which generates a series of voltage pulses having a frequency progressively increasing with increasing vehicle speed. The speed transducer 32 may take the form of a slotted disc rotated by a vehicle wheel adjacent a magnetic pickup whose output is a series of voltage pulses having the frequency related to vehicle speed. These voltage pulses are supplied to a frequency-to-voltage converter 34 whose output is a voltage having a magnitude progressively increasing with increasing vehicle speed. The output of the frequency-to-voltage converter 34 is coupled to the positive input of the summing switch 14 through a resistor 35. The resulting current supplied by the frequency-to-voltage converter 34, hereinafter referred to as the speed signal, has a magnitude progressively increasing with increasing vehicle speed.”</p> <p>E.g., FIG. 1</p>
<p>a processor subsystem, coupled to each one of said plurality of sensors, to receive data therefrom;</p>	<p>E.g., page 12.1, “The electronic engine control system consists of <i>sensing devices which continuously measure the operating conditions of the engine, an electronic control unit (ECU) which evaluates the sensor inputs</i> using data tables and calculations and determines the output to the actuating devices, and actuating devices which are commanded by the ECU to perform an action in response to the sensor inputs.”</p> <p>E.g., page 22.6, “During the entire operating time of the vehicle, <i>the ECUs are constantly supervising the sensors they are connected to</i>.”</p> <p>E.g., page 13.4, “On the functional side, the hardware configuration can be divided into power supply, input signal transfer circuits, output stages, and <i>microcontroller</i>, including peripheral components and</p>	<p>E.g., FIG. 1</p> <p>E.g., col. 2, lines 52 to 58, “By conventional circuit design techniques, the magnitude of the speed signal may be made to equal the difference between the magnitude of the reference signal and the magnitude of the vacuum signal when the manifold vacuum is at the level determined to represent excessive fuel consumption at the instantaneous speed represented by the output of the speed transducer 32.”</p>

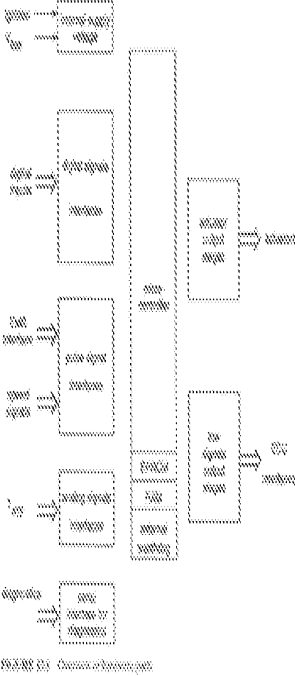
Limitation of '781 Patent Claim 28	Automotive Electronics Handbook (Jurgen)	U.S. Patent No. 3,925,753 (GM '753)
	<p>monitoring and safety circuits (Fig. 13.1)."</p> <p>E.g., Figure 13.1:</p>  <p>E.g., page 14.3, "The speed sensor is one of the most critical parts in the system, because the <i>microcontroller calculates the vehicle speed from the speed sensor's signal</i> to within 1/32 m/h."</p>	
<p>a fuel overinjection notification circuit coupled to said processor subsystem, said fuel overinjection notification circuit issuing a notification that excessive fuel is being supplied to said engine of said vehicle;</p>	<p>E.g., page 12.22, "During an acceleration transition, the ECU adds a correction factor (an increase) to the commanded injector pulse width. The sudden increase in air results in a lean mixture which must be corrected swiftly to obtain good transitional response. <i>During a deceleration transition, the fuel can be shut off by simply not providing a pulse width signal to the injector to minimize exhaust emissions and fuel consumption.</i>"</p> <p>E.g., page 12.4, "During coasting and braking, fuel</p>	<p>E.g., col. 2, lines 10 to 15, "The lamp 30 may be located at the vehicle instrument panel or any other location where it is readily observable by the vehicle operator. Alternatively, the lamp 30 may be replaced with a buzzer to provide an audible indication."</p> <p>E.g., col. 2, lines 52 to 58, "By conventional circuit design techniques, the magnitude of the speed signal may be made to equal the difference between the magnitude of the reference signal and the magnitude of the vacuum</p>



Limitation of '781 Patent Claim 28	Automotive Electronics Handbook (Jurgen)	U.S. Patent No. 3,925,753 (GM '753)
	<p>consumption can be further reduced by shutting off the fuel until the engine speed decreases to slightly higher than the set idle speed. <i>The ECU determines when fuel shutoff can occur by evaluating the throttle position, engine RPM, and vehicle speed.</i></p> <p>E.g., page 12.14, "Using the inputs of engine RPM and vehicle speed to the electronic control unit, thresholds can be established for limiting these variables with fuel cutoff. <i>When the maximum speed is achieved, the fuel injectors are shut off.</i> When the speed decreases below the threshold, fuel injection resumes."</p> <p>E.g., page 12.17, "<i>During transition to fuel cutoff, the ignition timing is retarded from its current setting to reduce engine torque and to assist in engine braking. The fuel is then shut off.</i> During the transition, the throttle bypass valve or the main throttle valve may remain open for a short period to allow fresh air to oxidize the remaining unburned HC and CO to further reduce exhaust emissions. During development of the fuel cutoff strategy, the advantage of reduced emission effects and catalyst temperature control must be balanced against driveability requirements. The use of fuel cutoff may change the perceived amount of engine braking felt by the driver. In addition, care must be taken to avoid a 'bump' feel when entering the fuel cutoff mode, due to the change in torque."</p>	<p>signal when the manifold vacuum is at the level determined to represent excessive fuel consumption at the instantaneous speed represented by the output of the speed transducer 32."</p> <p>E.g., col. 3, lines 20 to 27, "When the vehicle is operated in a manner such that the manifold vacuum decreases below the manifold vacuum trigger level established at the instantaneous vehicle speed, the output of the summing switch 14 swings positive to effect energization of the lamp 30 to provide an indication of fuel consumption in excess of the predetermined amount at that speed."</p>
<p>said processor subsystem determining whether to activate said fuel overinjection notification sensor based upon data received from said road speed sensor, said throttle position sensor and said manifold pressure sensor.</p>	<p>E.g., page 12.4, "During coasting and braking, fuel consumption can be further reduced by shutting off the fuel until the engine speed decreases to slightly higher than the set idle speed. <i>The ECU determines when fuel shutoff can occur by evaluating the throttle position, engine RPM, and vehicle speed.</i></p> <p>E.g., page 12.14, "Using the inputs of engine RPM and vehicle speed to the electronic control unit, thresholds can be established for limiting these variables with fuel</p>	<p>E.g., col. 2, lines 52 to 58, "By conventional circuit design techniques, the magnitude of the speed signal may be made to equal the difference between the magnitude of the reference signal and the magnitude of the vacuum signal when the manifold vacuum is at the level determined to represent excessive fuel consumption at the instantaneous speed represented by the output of the speed transducer 32."</p> <p>E.g., col. 2, lines 59 to 64, "By combining the speed</p>

Limitation of '781 Patent Claim 28	Automotive Electronics Handbook (Jurgen)	U.S. Patent No. 3,925,753 (GM '753)
	<p>cutoff. <i>When the maximum speed is achieved, the fuel injectors are shut off.</i> When the speed decreases below the threshold, fuel injection resumes.”</p> <p>E.g., pages 13.7 to 13.9, “<i>The basic functions of the transmission control are the shift point control, the lockup control, engine torque control during shifting, related safety functions, and diagnostic functions for vehicle service.</i>”</p> <p>E.g., page 13.9, “The basic shift point control uses shift maps, which are defined in data in the unit memory. These shift maps are selectable over a wide range. <i>The shift point limitations are made, on the one hand, by the highest admissible engine speed for each application and, on the other hand, by the lowest engine speed that is practical for driving comfort and noise emission. The inputs of the shift point determination are the throttle position, the accelerator pedal position, and the vehicle speed (determined by the transmission output speed).</i>”</p>	<p>signal in proper sense with the reference signal, the manifold vacuum level at which the output of the summing switch 14 swings positive to effect energization of the lamp 30, herein referred to as the manifold vacuum trigger level, may be increased as a function of vehicle speed.”</p> <p>E.g., col. 3, lines 20 to 27, “When the vehicle is operated in a manner such that the manifold vacuum decreases below the manifold vacuum trigger level established at the instantaneous vehicle speed, the output of the summing switch 14 swings positive to effect energization of the lamp 30 to provide an indication of fuel consumption in excess of the predetermined amount at that speed.”</p>

Limitation of '781 Patent Claim 29	Automotive Electronics Handbook (Jurgen)	U.S. Patent No. 3,925,753 (GM '753)
29. Apparatus according to claim 28 and further comprising:	See claim 28 claim chart, at page A-213.	See claim 28 claim chart, at page A-213.
a memory subsystem, coupled to said processor subsystem, said memory subsystem maintaining a manifold pressure set point;	<p>E.g., page 13.5, "The calculators inside the control units are usually microcontrollers. . . . <i>The memory devices for program and data are usually EPROMS.</i> Their storage capacity is, in present applications, up to 64 Kbytes. Future applications will necessitate storage sizes up to 128 Kbytes. The failure storages for diagnostics and the storage for adaptive data are in conventional applications, battery voltage-supplied RAMs. These are increasingly being replaced by EEPROMs."</p> <p>E.g., page 12.9, "A subsystem of the fuel control system is lambda closed-loop control. . . .</p> <p>[T]he engine control unit uses an anticipatory control strategy that uses engine load and RPM to determine the approximate fuel requirement. <i>The engine load information is provided by the manifold pressure sensor for speed density systems and by the air meter for air flow and air mass measurement systems and by the throttle valve position sensor. The engine control unit contains data tables for combinations of load and RPM.</i> This allows for rapid response to changes in operating conditions. The lambda sensor still provides the feedback correction for each load/RPM point. . . .</p> <p>[T]he electronic control unit has a feature for adapting changes in the fuel required for the load/RPM points. <i>At each load/RPM point, the lambda sensor continuously provides information that allows the system to adjust the fuel to the commanded A/F ratio. The corrected information is stored in RAM (random access memory) so that the next time the engine reaches that operating point (load/RPM), the anticipatory value will require less correction. These values remain stored in the electronic control unit even after the engine is shut off.</i> Only if power to the electronic control unit is disrupted</p>	<p>E.g., FIG. 1</p> <p>E.g., col. 2, lines 52 to 58, "By conventional circuit design techniques, the magnitude of the speed signal may be made to equal the difference between the magnitude of the reference signal and the magnitude of the vacuum signal when the manifold vacuum is at the level determined to represent excessive fuel consumption at the instantaneous speed represented by the output of the speed transducer 32."</p> <p>E.g., col. 3, lines 20 to 27, "When the vehicle is operated in a manner such that the manifold vacuum decreases below the manifold vacuum trigger level established at the instantaneous vehicle speed, the output of the summing switch 14 swings positive to effect energization of the lamp 30 to provide an indication of fuel consumption in excess of the predetermined amount at that speed."</p>

Limitation of '781 Patent Claim 29	Automotive Electronics Handbook (Jurgen)	U.S. Patent No. 3,925,753 (GM '753)
	<p>(i.e., due to a dead battery), will the correction be lost. In that case, the electronic control unit will revert back to the original production values that are written in ROM (read-only memory).”</p> <p>E.g., page 14.2, “Other safety-related items include <i>program code to detect abnormal operating conditions and preserving into memory the data points associated with the abnormal condition for later diagnostics.</i> Abnormal conditions, for example, could be an intermittent vehicle speed sensor, or erratic driver switch signals.”</p> <p>E.g., pages 22.2 to 22.3, “The most important test points of control units and sensors are tied to a diagnostic connector which is plugged into the measuring instrument with a corresponding adapter for the respective vehicle. . . . <i>Modern electronics in vehicles support diagnosis by comparing the registered actual value with the internally stored nominal values</i> with the help of control units and their self-diagnosis, thus detecting faults.”</p>	
<p>said processor subsystem activating said fuel overinjection notification circuit upon determining that:</p>	<p>E.g., page 12.22, “During an acceleration transition, the ECU adds a correction factor (an increase) to the commanded injector pulse width. The sudden increase in air results in a lean mixture which must be corrected swiftly to obtain good transitional response. <i>During a deceleration transition, the fuel can be shut off by simply not providing a pulse width signal to the injector to minimize exhaust emissions and fuel consumption.</i>”</p> <p>E.g., page 12.4, “During coasting and braking, fuel consumption can be further reduced by shutting off the fuel until the engine speed decreases to slightly higher than the set idle speed. <i>The ECU determines when fuel shutoff can occur by evaluating the throttle position, engine RPM, and vehicle speed.</i>”</p>	<p>E.g., col. 2, lines 52 to 58, “By conventional circuit design techniques, the magnitude of the speed signal may be made to equal the difference between the magnitude of the reference signal and the magnitude of the vacuum signal when the manifold vacuum is at the level determined to represent excessive fuel consumption at the instantaneous speed represented by the output of the speed transducer 32.”</p> <p>E.g., col. 2, lines 59 to 64, “By combining the speed signal in proper sense with the reference signal, the manifold vacuum level at which the output of the summing switch 14 swings positive to effect energization of the lamp 30, herein referred to as the manifold vacuum trigger level, may be increased as a function of vehicle speed.”</p>

Limitation of '781 Patent Claim 29	Automotive Electronics Handbook (Jurgen)	U.S. Patent No. 3,925,753 (GM '753)
	<p>E.g., page 12.14, "Using the inputs of engine RPM and vehicle speed to the electronic control unit, thresholds can be established for limiting these variables with fuel cutoff. <b>When the maximum speed is achieved, the fuel injectors are shut off.</b> When the speed decreases below the threshold, fuel injection resumes."</p> <p>E.g., page 12.17, "<b>During transition to fuel cutoff, the ignition timing is retarded from its current setting to reduce engine torque and to assist in engine braking. The fuel is then shut off.</b> During the transition, the throttle bypass valve or the main throttle valve may remain open for a short period to allow fresh air to oxidize the remaining unburned HC and CO to further reduce exhaust emissions. During development of the fuel cutoff strategy, the advantage of reduced emission effects and catalyst temperature control must be balanced against driveability requirements. The use of fuel cutoff may change the perceived amount of engine braking felt by the driver. In addition, care must be taken to avoid a 'bump' feel when entering the fuel cutoff mode, due to the change in torque."</p>	<p>E.g., col. 3, lines 20 to 27, "When the vehicle is operated in a manner such that the manifold vacuum decreases below the manifold vacuum trigger level established at the instantaneous vehicle speed, the output of the summing switch 14 swings positive to effect energization of the lamp 30 to provide an indication of fuel consumption in excess of the predetermined amount at that speed."</p>
<p>(1) based upon data received from said road speed sensor, road speed of said vehicle is increasing;</p>	<p>E.g., page 7.6, "There are several applications for rotational speed sensing. First it is necessary to monitor engine speed. This information is used for transmission control, engine control, cruise control, and possibly for a tachometer. Electronics and electronic sensing in the automobile were brought about by the need for higher efficiency engines, better fuel economy, increased power and performance, and lower emissions. Second, <b>wheel speed sensing is required</b> for use in transmissions, cruise control, speedometers, antilock brake systems (ABS), traction control (ASR), variable ratio power steering assist, four-wheel steering, and possibly in inertial navigation and air bag deployment applications."</p> <p>E.g., page 7.8, "In electronic transmission applications, <b>information from the road and engine speed sensors, as</b></p>	<p>E.g., col. 2, lines 34 to 51, "<b>To provide a manifold vacuum trigger level which increases with increasing vehicle speed, a speed transducer 32 is provided which generates a series of voltage pulses having a frequency progressively increasing with increasing vehicle speed.</b> The speed transducer 32 may take the form of a slotted disc rotated by a vehicle wheel adjacent a magnetic pickup whose output is a series of voltage pulses having the frequency related to vehicle speed. These voltage pulses are supplied to a frequency-to-voltage converter 34 whose output is a voltage having a magnitude progressively increasing with increasing vehicle speed. The output of the frequency-to-voltage converter 34 is coupled to the positive input of the summing switch 14 through a resistor 35. The resulting current supplied by the frequency-to-voltage converter 34, hereinafter</p>

Limitation of '781 Patent Claim 29	Automotive Electronics Handbook (Jurgen)	U.S. Patent No. 3,925,753 (GM '753)
	well as torque data and throttle position are required for the MCU to select the optimum gear ratio.”	referred to as the speed signal, has a magnitude progressively increasing with increasing vehicle speed.”  E.g., FIG. 1
(2) based upon data received from said throttle position sensor, throttle position for said vehicle is increasing; and	E.g., page 12.18, “To control the idle speed, the ECU uses inputs from the <i>throttle position sensor</i> , air conditioning, automatic transmission, power steering, charging system, engine RPM, and vehicle speed.”  E.g., page 12.21, “The electronic injection unit also houses the <i>throttle position sensor</i> and, in some cases, an inlet air temperature sensor which provides operating condition information to the ECU.”	
(3) based upon data received from said manifold pressure sensor, manifold pressure for said vehicle exceeds said manifold pressure set point.	E.g., page 2.5, “Automotive specification and testing guidelines have been developed and published by the Society of Automotive Engineers (SAE) specifically for <i>manifold absolute pressure (MAP) sensors</i> .”  E.g., page 2.7, “Manifold absolute pressure (MAP) is used as an input to fuel and ignition control in internal combustion engine control systems. <i>The speed-density system that uses the MAP sensor</i> has been preferred over mass air flow (MAF) control because it's less expensive, but stricter emission standards are causing more manufacturers to use mass air flow for future models.”	E.g., col. 3, lines 20 to 27, “When the vehicle is operated in a manner such that the manifold vacuum decreases below the manifold vacuum trigger level established at the instantaneous vehicle speed, the output of the summing switch 14 swings positive to effect energization of the lamp 30 to provide an indication of fuel consumption in excess of the predetermined amount at that speed.”  E.g., col. 3, lines 20 to 27, “When the vehicle is operated in a manner such that the manifold vacuum decreases below the manifold vacuum trigger level established at the instantaneous vehicle speed, the output of the summing switch 14 swings positive to effect energization of the lamp 30 to provide an indication of fuel consumption in excess of the predetermined amount at that speed.”

Limitation of '781 Patent Claim 30	Automotive Electronics Handbook (Jurgen)	U.S. Patent No. 3,925,753 (GM '753)
30. Apparatus according to claim 28, wherein:	See claim 28 claim chart, at page A-213.	See claim 28 claim chart, at page A-213.
said plurality of sensors coupled to said vehicle further include an engine speed sensor;	<p>E.g., page 7.6, "There are several applications for rotational speed sensing. <i>First it is necessary to monitor engine speed.</i> This information is used for transmission control, engine control, cruise control, and possibly for a tachometer. Electronics and electronic sensing in the automobile were brought about by the need for higher efficiency engines, better fuel economy, increased power and performance, and lower emissions. Second, <i>wheel speed sensing is required</i> for use in transmissions, cruise control, speedometers, antilock brake systems (ABS), traction control (ASR), variable ratio power steering assist, four-wheel steering, and possibly in inertial navigation and air bag deployment applications."</p> <p>E.g., page 7.8, "In electronic transmission applications, <i>information from the road and engine speed sensors</i>, as well as torque data and throttle position are required for the MCU to select the optimum gear ratio."</p>	
said processor subsystem activating said fuel overinjection notification circuit upon determining that:	<p>E.g., page 12.4, "During coasting and braking, fuel consumption can be further reduced by shutting off the fuel until the engine speed decreases to slightly higher than the set idle speed. <i>The ECU determines when fuel shutoff can occur by evaluating the throttle position, engine RPM, and vehicle speed.</i>"</p> <p>E.g., page 12.14, "Using the inputs of engine RPM and vehicle speed to the electronic control unit, thresholds can be established for limiting these variables with fuel cutoff. <i>When the maximum speed is achieved, the fuel injectors are shut off.</i> When the speed decreases below the threshold, fuel injection resumes."</p> <p>E.g., pages 13.7 to 13.9, "<i>The basic functions of the transmission control are the shift point control</i>, the lockup control, engine torque control during shifting, related safety functions, and diagnostic functions for vehicle service."</p> <p>E.g., page 13.9, "The basic shift point control uses shift maps, which are defined in data in the unit memory. These shift maps</p>	<p>E.g., col. 2, lines 52 to 58, "By conventional circuit design techniques, the magnitude of the speed signal may be made to equal the difference between the magnitude of the reference signal and the magnitude of the vacuum signal when the manifold vacuum is at the level determined to represent excessive fuel consumption at the instantaneous speed represented by the output of the speed transducer 32."</p> <p>E.g., col. 2, lines 59 to 64, "By combining the speed signal in proper sense with the reference signal, the manifold vacuum level at which the output of the summing switch 14 swings positive to effect energization of the lamp 30, herein referred to as the manifold vacuum trigger level, may be increased as a function of vehicle speed."</p> <p>E.g., col. 3, lines 20 to 27, "When the vehicle is operated in a manner such that the manifold vacuum</p>

Limitation of '781 Patent Claim 30	Automotive Electronics Handbook (Jurgen)	U.S. Patent No. 3,925,753 (GM '753)
	<p>are selectable over a wide range. <i>The shift point limitations are made</i>, on the one hand, by the highest admissible engine speed for each application and, on the other hand, <i>by the lowest engine speed that is practical for driving comfort and noise emission. The inputs of the shift point determination are the throttle position, the accelerator pedal position, and the vehicle speed</i> (determined by the transmission output speed).”</p>	<p>decreases below the manifold vacuum trigger level established at the instantaneous vehicle speed, the output of the summing switch 14 swings positive to effect energization of the lamp 30 to provide an indication of fuel consumption in excess of the predetermined amount at that speed.”</p>
<p>(1) based upon data received from said road speed sensor, road speed of said vehicle is decreasing;</p>	<p>E.g., page 7.6, “There are several applications for rotational speed sensing. First it is necessary to monitor engine speed. This information is used for transmission control, engine control, cruise control, and possibly for a tachometer. Electronics and electronic sensing in the automobile were brought about by the need for higher efficiency engines, better fuel economy, increased power and performance, and lower emissions. Second, <i>wheel speed sensing is required</i> for use in transmissions, cruise control, speedometers, antilock brake systems (ABS), traction control (ASR), variable ratio power steering assist, four-wheel steering, and possibly in inertial navigation and air bag deployment applications.”</p> <p>E.g., page 7.8, “In electronic transmission applications, <i>information from the road and engine speed sensors</i>, as well as torque data and throttle position are required for the MCU to select the optimum gear ratio.”</p>	<p>E.g., col. 2, lines 34 to 51, “<i>To provide a manifold vacuum trigger level which increases with increasing vehicle speed, a speed transducer 32 is provided which generates a series of voltage pulses having a frequency progressively increasing with increasing vehicle speed.</i> The speed transducer 32 may take the form of a slotted disc rotated by a vehicle wheel adjacent a magnetic pickup whose output is a series of voltage pulses having the frequency related to vehicle speed. These voltage pulses are supplied to a frequency-to-voltage converter 34 whose output is a voltage having a magnitude progressively increasing with increasing vehicle speed. The output of the frequency-to-voltage converter 34 is coupled to the positive input of the summing switch 14 through a resistor 35. The resulting current supplied by the frequency-to-voltage converter 34, hereinafter referred to as the speed signal, has a magnitude progressively increasing with increasing vehicle speed.”</p> <p>E.g., FIG. 1</p>
<p>(2) based upon data received from said throttle position sensor, throttle position for said vehicle is increasing;</p>	<p>E.g., page 12.18, “To control the idle speed, the ECU uses inputs from the <i>throttle position sensor</i>, air conditioning, automatic transmission, power steering, charging system, engine RPM, and vehicle speed.”</p> <p>E.g., page 12.21, “The electronic injection unit also houses the <i>throttle position sensor</i> and, in some cases, an inlet air temperature sensor which provides operating condition information to the ECU.”</p>	



Limitation of '781 Patent Claim 30	Automotive Electronics Handbook (Jurgen)	U.S. Patent No. 3,925,753 (GM '753)
<p>(3) based upon data received from said manifold pressure sensor, manifold pressure for said vehicle is increasing; and</p>	<p>E.g., page 2.5, "Automotive specification and testing guidelines have been developed and published by the Society of Automotive Engineers (SAE) specifically for <i>manifold absolute pressure (MAP) sensors</i>."</p> <p>E.g., page 2.7, "Manifold absolute pressure (MAP) is used as an input to fuel and ignition control in internal combustion engine control systems. <i>The speed-density system that uses the MAP sensor</i> has been preferred over mass air flow (MAF) control because it's less expensive, but stricter emission standards are causing more manufacturers to use mass air flow for future models."</p>	<p>E.g., col. 3, lines 20 to 27, "When the vehicle is operated in a manner such that the manifold vacuum decreases below the manifold vacuum trigger level established at the instantaneous vehicle speed, the output of the summing switch 14 swings positive to effect energization of the lamp 30 to provide an indication of fuel consumption in excess of the predetermined amount at that speed."</p> <p>E.g., col. 3, lines 20 to 27, "When the vehicle is operated in a manner such that the manifold vacuum decreases below the manifold vacuum trigger level established at the instantaneous vehicle speed, the output of the summing switch 14 swings positive to effect energization of the lamp 30 to provide an indication of fuel consumption in excess of the predetermined amount at that speed."</p>
<p>(4) based upon data received from said engine speed sensor, engine speed for said vehicle is decreasing.</p>	<p>E.g., page 7.6, "There are several applications for rotational speed sensing. <i>First it is necessary to monitor engine speed</i>. This information is used for transmission control, engine control, cruise control, and possibly for a tachometer. Electronics and electronic sensing in the automobile were brought about by the need for higher efficiency engines, better fuel economy, increased power and performance, and lower emissions. Second, <i>wheel speed sensing is required</i> for use in transmissions, cruise control, speedometers, antilock brake systems (ABS), traction control (ASR), variable ratio power steering assist, four-wheel steering, and possibly in inertial navigation and air bag deployment applications."</p> <p>E.g., page 7.8, "In electronic transmission applications, <i>information from the road and engine speed sensors</i>, as well as torque data and throttle position are required for the MCU to select the optimum gear ratio."</p>	

10. Claim 31 is Anticipated by Davidian

Limitation of '781 Patent Claim 31	U.S. Patent No. 5,357,438 (Davidian)
31. Apparatus for optimizing operation of a vehicle, comprising:	E.g., col. 1, lines 1 to 2, "The present invention relates to <i>an anti-collision system for vehicles.</i> "
a radar detector, said radar detector determining a distance separating a vehicle having an engine and an object in front of said vehicle;	<p>E.g., col. 4, lines 52 to 66, "<i>Vehicle 2 further includes a front space sensor 8 for sensing the space in front of the vehicle, such as the presence of another vehicle, a corresponding rear space sensor 10, and a pair of side sensors 11.</i> All the space sensors are in the form of pulse (e.g., ultrasonic) transmitters and receivers, for determining the distance of the vehicle from an object, e.g., another vehicle, at front or rear. Space sensors may also be provided at the sides of the vehicle. Vehicle 2 is further equipped with a speed sensor 12 which may sense the speed of the vehicle in any known manner, for example using the speed measuring system of the vehicle itself, or a speed measuring system independent of the vehicle, e.g., an acceleration sensor, or by calculations based on the Doppler effect, etc."</p> <p>E.g., col. 10, lines 17 to 26, "FIG. 7 is a circuit diagram of the microcomputer 4 and the other components of the electrical system. The microprocessor is indicated by block 100, its power supply by block 102, and its watchdog circuit by block 104. <i>It includes a transmitter 106 and a receiver 108 for transmitting and receiving the pulses (e.g., RF, ultrasound, laser, IR, etc.) in the front space sensor 8 and the rear space sensor 10 for measuring the distance of the vehicle from objects in front of, and to the rear, of the vehicle, respectively.</i>"</p> <p>E.g., col. 10, lines 38 to 50, "As indicated earlier, the distance of the vehicle from an object is determined by the front space sensor 8 with respect to objects in front of the vehicle, and by the rear space sensor 10 with respect to objects at the rear of the vehicle. Each of these space sensors may be of known construction, including a transmitter as indicated at 106 in FIG. 7, and a receiver as indicated at 108. <i>Thus, pulses are continuously transmitted by each transmitter, and the echoes from the objects in front of or to the rear of the vehicle are received by the respective receiver. The computer then measures the round-trip time from the pulse transmission to the echo reception in order to determine the distance of the vehicle from the object.</i>"</p>
at least one sensor coupled to said vehicle for monitoring operation thereof, said at least one sensor including a road speed sensor;	E.g., col. 4, lines 60 to 66, "Vehicle 2 is further equipped with <i>a speed sensor 12 which may sense the speed of the vehicle in any known manner,</i> for example using the speed measuring system of the vehicle itself, or a speed measuring system independent of the vehicle, e.g., an acceleration sensor, or by calculations based on the Doppler effect,

Limitation of '781 Patent Claim 31	U.S. Patent No. 5,357,438 (Davidian)
	etc.”
<p>a processor subsystem, coupled to said radar detector and said at least one sensor, to receive data therefrom;</p>	<p>E.g., col. 8, lines 29 to 43, “<i>FIGS. 6a, 6b, are a block diagram illustrating the microcomputer 4 and its inputs and outputs described earlier which enable it to continuously monitor the operation of the vehicle</i> and to actuate first a Safety alarm, and then a Collision alarm whenever the vehicle may enter a danger-of-collision situation according to the various preset parameters and automatic parameters introduced into the computer.</p> <p><i>The microcomputer 4 as illustrated in FIGS. 6a, 6b is divided into various functional modules, as follows: a calculation module 90, which receives data concerning the various parameters briefly described above</i> and as will be described more particularly below to enable it to make the necessary computations for actuating the Safety alarm and the Collision alarm.”</p> <p>E.g., col. 8, lines 58 to 60, “Thus, module 90 receives inputs from the front space sensor 8, the rear space sensor 10, and the vehicle speed sensor 12.”</p> <p>E.g., Figure 6A:</p>

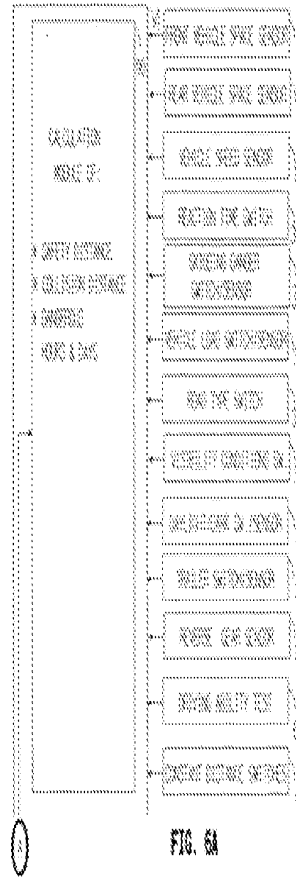

a memory subsystem, coupled to said processor subsystem, said memory subsystem storing a first vehicle speed/stopping distance table;

E.g., col. 9, lines 20 to 27, “Computer module 90 also includes information about the vehicle braking distances as a function of speed. This is preferably in the form of a look-up table, for example, provided by the manufacturer for predetermined defined conditions concerning road type, skidding danger, vehicle load and tires pressure, and is stored in a ROM (read-only memory) of the microcomputer so that it can be changed periodically if necessary.”

E.g., col. 12, line 59 to col 13, line 22, “The system then makes the computations illustrated (as an example) in block 162 to determine the stopping distance SD, which is equal to the reaction distance plus the braking distance multiplied by a stopping factor ST and a safety factor SF. In the illustrated example, the stopping distance is the sum of the reaction distance and the braking distance. The reaction distance is the product of the reaction time, visibility condition, daylight condition, reaction factor and speed; and the braking distance is the product of the braking distance (as

Limitation of '781 Patent Claim 31	U.S. Patent No. 5,357,438 (Davidian)
	<p><i>supplied by the manufacturer), road type, skidding danger, vehicle load and braking factor.</i> The stopping distance (SD) includes further safety factors, and determines when the safety alarm will be actuated to first alert the driver of an approaching collision danger.</p> <p><i>A determination is also made of the collision distance CD which is equal to the stopping distance SD divided by the collision safety factor CSF, e.g., 1.25 in the example illustrated above, such that should the distance between the vehicle and the object come within the collision distance CD, the collision alarm is then actuated.</i></p> <p>The foregoing calculations of stopping distance SD and collision distance CD with respect to objects at the front of the vehicle are also made with respect to objects at the rear of the vehicle, these calculations being RSD and RCD, respectively, also shown in block 162.</p> <p>Whenever the distance between the vehicle and an object to the front of the vehicle or to the rear of the vehicle comes within the stopping distance SD and the collision distance CD, the system operates according to the deceleration alarm module 93, as indicated by block 164.”</p>
<p>a vehicle proximity alarm circuit coupled to said processor subsystem, said vehicle proximity alarm circuit issuing an alarm that said vehicle is too close to said object;</p>	<p>E.g., col. 3, lines 59 to 66, “The anti-collision system illustrated in FIGS. 1-14 is particularly useful for motor vehicles (passengers cars, buses, trucks) in order to <i>actuate an alarm when the vehicle is travelling at a distance behind another vehicle or in front of another</i>, which is equal to or less than a danger-of-collision distance computed by a computer such that if the front vehicle stops suddenly there is a danger of a rear-end collision.”</p> <p>E.g., col. 4, lines 14 to 16, “In the system described below, <i>there are two alarms: a Collision alarm, which is actuated when the vehicle is determined to be within the danger-of-collision distance; and a Safety alarm, which is actuated before the Collision alarm, at a distance greater than the danger-of-collision distance by a predetermined safety factor</i>, e.g., 1.25.”</p> <p>E.g., col. 6, lines 25 to 29, “Control panel 6 further includes a front distance display 46, in which are displayed the distance to the front vehicle (in region 46a), in which direction (by arrow 46b), and <i>whether or not there is a collision danger (region 46c).</i>”</p> <p>E.g., col. 6, lines 41 to 46, “Control panel 6 further includes a speaker 54 for producing an <i>audio alarm in the event of a collision danger, in addition to the visually-indicated</i></p>

Limitation of '781 Patent Claim 31	U.S. Patent No. 5,357,438 (Davidian)
	<p><i>alarms</i> of sections 46c and 48c of the displays 46 and 48.”</p> <p>E.g., col. 8, lines 37 to 48, “The <i>microcomputer 4</i> as illustrated in FIGS. 6a, 6b is divided into various functional modules, as follows:  <i>... a deceleration alarm module 93, which controls the Safety alarm and Collision alarm on the control panel, ...</i>”</p> <p>E.g., Figs. 3 and 6B (ref. no. 46C)</p>
<p>said processor subsystem determining whether to activate said vehicle proximity alarm circuit based upon separation distance data received from said radar detector, vehicle speed data received from said road speed sensor and said first vehicle speed/stopping distance table stored in said memory subsystem.</p>	<p>E.g., col. 8, lines 37 to 43, “The <i>microcomputer 4</i> as illustrated in FIGS. 6a, 6b is divided into various functional modules, as follows: a calculation module 90, <i>which receives data concerning the various parameters briefly described above</i> and as will be described more particularly below <i>to enable it to make the necessary computations for actuating the Safety alarm and the Collision alarm; ...</i>”</p> <p>E.g., col. 12, line 59 to col 13, line 11, “The system then makes the computations illustrated (as an example) in block 162 to determine the stopping distance SD, which is equal to the reaction distance plus the braking distance multiplied by a stopping factor ST and a safety factor SF. In the illustrated example, the stopping distance is the sum of the reaction distance and the braking distance. The reaction distance is the product of the reaction time, visibility condition, daylight condition, reaction factor and speed; and the braking distance is the product of the braking distance (as supplied by the manufacturer), road type, skidding danger, vehicle load and braking factor. <i>The stopping distance (SD) includes further safety factors, and determines when the safety alarm will be actuated to first alert the driver of an approaching collision danger.</i></p> <p><i>A determination is also made of the collision distance CD which is equal to the stopping distance SD divided by the collision safety factor CSF, e.g., 1.25 in the example illustrated above, such that should the distance between the vehicle and the object come within the collision distance CD, the collision alarm is then actuated.”</i></p> <p>E.g., col. 13, lines 17 to 22, “<i>Whenever the distance between the vehicle and an object to the front of the vehicle or to the rear of the vehicle comes within the stopping distance SD and the collision distance CD, the system operates according to the deceleration alarm module 93, as indicated by block 164.</i>”</p>

**11. Claims 31 and 32 are Obvious in View of the Combination of Tonkin and Doi et al.**

Limitation of '781 Patent Claim 31	PCT Publication No. WO 96/02853 (Tonkin)	U.S. Patent No. 5,708,584 (Doi et al.)
<p>31. Apparatus for optimizing operation of a vehicle, comprising:</p>	<p>E.g., Abstract, “The system comprising a controller fitted to a subject vehicle (16) and sensor means (20) operable to sense a distance of separation and relative velocity of a trailing vehicle (18). Also input to the controller is a velocity signal derived from a velocity sensing means (97) determining the ground speed of the subject vehicle using a doppler radar system. The controller calculates a safety envelope and activates a visible warning device attached to the rear of the subject vehicle if the trailing vehicle penetrates the safety envelope. An enhanced safety envelope determined by adverse road conditions is also established, any incursion into the enhanced envelope resulting generally in the visible warning being at a less prominent level. If however the closing speed of the trailing vehicle exceeds a predetermined threshold, penetration of the enhanced envelope results immediately in the full warning being displayed with full prominence to the driver of the trailing vehicle. The system has application to improving the safety of road vehicles.”</p>	<p>E.g., Abstract, “In a vehicle running mode detecting system, a relative speed of a vehicle, equipped with the vehicle running mode detecting system, to a forward object is calculated on the basis of a time elapsed is measured and a change in the distance between the vehicle and the forward object during the time elapsed.”</p>
<p>a radar detector, said radar detector determining a distance separating a vehicle having an engine and an object in front of said vehicle;</p>	<p>E.g., page 1, lines 23 to 29, “According to one aspect of the invention there is provided a safety system for vehicles comprising a controller fitted in use to a subject vehicle, <b><u>sensor means fitted to the subject vehicle in use and operable to sense a distance of separation and/or a relative velocity of a trailing vehicle</u></b> and operable to input data signals representative thereof to the controller.”</p> <p>E.g., page 5, lines 4 to 9, “<i>The sensor means for sensing the distance and velocity of the trailing vehicle may comprise a radar system</i> transmitting and receiving radar pulses, from which received pulses information is derived sufficient to determine both the proximity and relative speed of the trailing vehicle.”</p>	<p>E.g., col. 2, lines 58 to 62, “The <i>radar head unit 3</i> emits a pulse laser beam (as a radar wave) forward of the vehicle 1 from the source and receives reflected light beam reflected by a forward object in the way such as a vehicle, thereby measuring the distance from the vehicle 1 to the forward object.”</p> <p>E.g., col. 2, line 66 to col. 3, line 7, “As shown in FIG. 2, <i>signals from the radar head unit 3 and the vehicle speed sensor 5 which detects the running speed of the vehicle 1 are input into the control unit 4</i> and the running mode of the vehicle 1 is determined by the control unit 4 and shown by the headup display 6. <i>When it is determined that the forward object is an obstruction for the vehicle 1 to clear, the alarm 7 operates and the vehicle control device 8 automatically causes brakes 8a</i></p>

Limitation of '781 Patent Claim 31	PCT Publication No. WO 96/02853 (Tonkin)	U.S. Patent No. 5,708,584 (Doi et al.)
	E.g., FIG. 2A	<i>of the vehicle 1 to operate to decelerate vehicle 1.</i>  E.g., FIG. 3.
at least one sensor coupled to said vehicle for monitoring operation thereof, said at least one sensor including a road speed sensor;	E.g., page 5, lines 17 to 19, "The velocity sensing means may comprise a <i>conventional speed sensing device</i> fitted to the vehicle's transmission train and may for example include a hall effect sensor."	E.g., col. 2, lines 58 to 62, "The <i>radar head unit 3</i> emits a pulse laser beam (as a radar wave) forward of the vehicle 1 from the source and receives reflected light beam reflected by a forward object in the way such as a vehicle, thereby measuring the distance from the vehicle 1 to the forward object."  E.g., col. 2, line 66 to col. 3, line 7, "As shown in FIG. 2, signals from the radar head unit 3 and the <i>vehicle speed sensor 5 which detects the running speed of the vehicle 1</i> are input into the control unit 4 and the running mode of the vehicle 1 is determined by the control unit 4 and shown by the headup display 6. When it is determined that the forward object is an obstruction for the vehicle 1 to clear, the alarm 7 operates and the vehicle control device 8 automatically causes brakes 8a of the vehicle 1 to operate to decelerate vehicle 1."  E.g., FIG. 3.
a processor subsystem, coupled to said radar detector and said at least one sensor, to receive data therefrom;	E.g., page 1, lines 32 to 34, "... <i>wherein the controller is operable to process the received velocity signal and data signals</i> to determine the existence of an unsafe condition."  E.g., page 3, lines 5 to 10, "The system in a preferred embodiment has a radar device having two receiver antenna which device <i>operably communicates with a controller which is able thereby to determine the direction of motion of the vehicle</i> , and warning means which is automatically actuated by the controller to provide a warning when the vehicle moves."	E.g., col. 2, lines 58 to 62, "The radar head unit 3 emits a pulse laser beam (as a radar wave) forward of the vehicle 1 from the source and receives reflected light beam reflected by a forward object in the way such as a vehicle, thereby measuring the distance from the vehicle 1 to the forward object."  E.g., col. 2, line 66 to col. 3, line 7, "As shown in FIG. 2, signals from the radar head unit 3 and the vehicle speed sensor 5 which detects the running speed of the vehicle 1 are <i>input into the control unit 4 and the running mode of the vehicle 1 is determined by the control unit 4</i> and shown by the headup display 6. When it is determined that the forward object is an obstruction for the vehicle 1 to clear, the alarm 7 operates and the vehicle control



Limitation of '781 Patent Claim 31	PCT Publication No. WO/96/02853 (Tonkin)	U.S. Patent No. 5,708,584 (Doi et al.)
		<p>device 8 automatically causes brakes 8a of the vehicle 1 to operate to decelerate vehicle 1.”</p> <p>E.g., FIG. 3.</p>
<p>a memory subsystem, coupled to said processor subsystem, said memory subsystem storing a first vehicle speed/stopping distance table;</p>	<p>E.g., page 3, lines 25 to 32, “The size of the enhanced safe distance and enlarged safety envelope will generally be predetermined so as to correspond to typical parameters appropriate for driving under adverse road conditions. <i>These parameters may for example be stored in a look up table</i> allowing the parameters to be determined from the signals received by the controller together with the parameters defining the normal safety envelope.”</p> <p>E.g., page 16, lines 2 to 21, “The control system is designed to activate display 12 to provide a warning signal to a driver of the trailing vehicle when the trailing vehicle 18 when the trailing vehicle is closing too rapidly on the subject vehicle 16 for example, alternately a warning signal is displayed when the trailing vehicle 18 is too close to the subject vehicle 16. Even if they are travelling at the same speed for example, <u>there are known safe stopping distances such as those published by the Minister of Transport</u>, in which a vehicle will stop when the brakes are applied. Accordingly, by knowing the velocity of the subject vehicle 16 for example preferably using the radar ground sensing system described herein, which provides therefore a true ground speed, or other means in communication with a microprocessor control system and by using a proximity sensor 20 to determine the separation of the subject vehicle 16 from the trailing vehicle 18 a safety envelope can be created behind the subject vehicle 16. Intrusion in the envelope by the trailing vehicle 18 causes an initial level of lamps 13 in array 12 to be lit.”</p> <p>E.g., page 17, lines 7 to 25, “Thus a warning system has been described using a ground speed sensor for a subject</p>	

Limitation of '781 Patent Claim 31	PCT Publication No. WO 96/02853 (Tonkin)	U.S. Patent No. 5,708,584 (Doi et al.)
	<p>vehicle 16 coupled by a microprocessor with a proximity sensor 20. In a more sophisticate [sic] version, proximity sensor 20 could be a radar device described herein for measuring velocity and could therefore be used to measure the relative velocity of a subject vehicle 16 and trailing vehicle 18. By knowing the closing speed of the trailing vehicle 18 predetermined values could be used to trigger warning displays if the closing speed is too great.</p> <p><i>For example, a look-up table or database could again be provided for unsafe closing speeds. This look-up table might again be varied according to the velocity of the subject vehicle 16 in a similar manner to the safe stopping distance, or safety envelope distance.</i></p> <p>Therefore, whilst the safety envelope distance at 30mph is 25 metres, if the trailing vehicle is closing too rapidly, say, a difference in speed of 30mph, then the warning signal could be activated even when the trailing vehicle 18 is 50 metres behind the subject vehicle 16.”</p>	
<p>a vehicle proximity alarm circuit coupled to said processor subsystem, said vehicle proximity alarm circuit issuing an alarm that said vehicle is too close to said object;</p>	<p>E.g., page 2, line 29 to Page 3, line 3, “<i>The system may comprise means for warning</i> that the subject vehicle is stationary. <i>The system can further comprise means for providing warning</i> of different levels of deceleration of the subject vehicle. <i>The warning means can comprise an orange light display for the relative speed and/or relative separation conditions and a red light display for the vehicle stationary and/or levels of deceleration conditions.</i> The relative separation and/or relative speed warning may be overridden by the level of deceleration warning.”</p> <p>E.g., page 3, lines 25 to 32, “The size of the enhanced safe distance and enlarged safety envelope will generally be predetermined so as to correspond to typical parameters appropriate for driving under adverse road conditions. These parameters may for example be stored in a look up table allowing the parameters to be determined from the signals received by the controller together with the parameters defining the normal safety</p>	<p>E.g., col. 2, lines 58 to 62, “The radar head unit 3 emits a pulse laser beam (as a radar wave) forward of the vehicle 1 from the source and receives reflected light beam reflected by a forward object in the way such as a vehicle, <i>thereby measuring the distance from the vehicle 1 to the forward object.</i>”</p> <p>E.g., col. 2, line 66 to col. 3, line 7, “As shown in FIG. 2, signals from the radar head unit 3 and the vehicle speed sensor 5 which detects the running speed of the vehicle 1 are input into the control unit 4 and the running mode of the vehicle 1 is determined by the control unit 4 and shown by the headup display 6. <i>When it is determined that the forward object is an obstruction for the vehicle 1 to clear, the alarm 7 operates and the vehicle control device 8 automatically causes brakes 8a of the vehicle 1 to operate to decelerate vehicle 1.</i>”</p> <p>E.g., FIG. 3.</p>

Limitation of '781 Patent Claim 31	PCT Publication No. WO 96/02853 (Tonkin)	U.S. Patent No. 5,708,584 (Doi et al.)
	<p>envelope.”</p> <p>E.g., page 16, lines 2 to 21, “<i>The control system is designed to activate display 12 to provide a warning signal to a driver of the trailing vehicle when the trailing vehicle 18 when the trailing vehicle is closing too rapidly on the subject vehicle 16</i> for example, alternately a warning signal is displayed when the trailing vehicle 18 is too close to the subject vehicle 16. Even if they are travelling at the same speed for example, there are known safe stopping distances such as those published by the Minister of Transport, in which a vehicle will stop when the brakes are applied. Accordingly, by knowing the velocity of the subject vehicle 16 for example preferably using the radar ground sensing system described herein, which provides therefore a true ground speed, or other means in communication with a microprocessor control system and by using a proximity sensor 20 to determine the separation of the subject vehicle 16 from the trailing vehicle 18 a safety envelope can be created behind the subject vehicle 16. <b>Intrusion in the envelope by the trailing vehicle 18 causes an initial level of lamps 13 in array 12 to be lit.</b>”</p> <p>E.g., page 17, lines 7 to 25, “<i>Thus a warning system has been described using a ground speed sensor for a subject vehicle 16 coupled by a microprocessor with a proximity sensor 20.</i> In a more sophisticate [sic] version, proximity sensor 20 could be a radar device described herein for measuring velocity and could therefore be used to measure the relative velocity of a subject vehicle 16 and trailing vehicle 18. By knowing the closing speed of the trailing vehicle 18 predetermined values could be used to trigger warning displays if the closing speed is too great. For example, a look-up table or database could again be provided for unsafe closing speeds. This look-up table might again be varied according to the velocity of the subject vehicle 16 in a</p>	

Limitation of '781 Patent Claim 31	PCT Publication No. WO 96/02853 (Tonkin)	U.S. Patent No. 5,708,584 (Doi et al.)
	<p>similar manner to the safe stopping distance, or safety envelope distance. Therefore, whilst the safety envelope distance at 30mph is 25 metres, if the trailing vehicle is closing too rapidly, say, a difference in speed of 30mph, then the warning signal could be activated even when the trailing vehicle 18 is 50 metres behind the subject vehicle 16.”</p>	
<p>said processor subsystem determining whether to activate said vehicle proximity alarm circuit based upon separation distance data received from said radar detector, vehicle speed data received from said road speed sensor and said first vehicle speed/stopping distance table stored in said memory subsystem.</p>	<p>E.g., page 2, line 29 to Page 3, line 3, “The system may comprise means for warning that the subject vehicle is stationary. The system can further comprise means for providing warning of different levels of deceleration of the subject vehicle. The warning means can comprise an orange light display for the relative speed and/or relative separation conditions and a red light display for the vehicle stationary and/or levels of deceleration conditions. The relative separation and/or relative speed warning may be overridden by the level of deceleration warning.”</p> <p>E.g., page 3, lines 25 to 32, “The size of the enhanced safe distance and enlarged safety envelope will generally be predetermined so as to correspond to typical parameters appropriate for driving under adverse road conditions. <i>These parameters may for example be stored in a look up table allowing the parameters to be determined from the signals received by the controller together with the parameters defining the normal safety envelope.</i>”</p> <p>E.g., page 16, lines 2 to 21, “The control system is designed to activate display 12 to provide a warning signal to a driver of the trailing vehicle when the trailing vehicle 18 when the trailing vehicle is closing too rapidly on the subject vehicle 16 for example, alternately a warning signal is displayed when the trailing vehicle 18 is too close to the subject vehicle 16. Even if they are travelling at the same speed for example, <i>there are known safe stopping distances such as those published</i></p>	<p>E.g., col. 2, lines 58 to 62, “The radar head unit 3 emits a pulse laser beam (as a radar wave) forward of the vehicle 1 from the source and receives reflected light beam reflected by a forward object in the way such as a vehicle, thereby measuring the distance from the vehicle 1 to the forward object.”</p> <p>E.g., col. 2, line 66 to col. 3, line 7, “As shown in FIG. 2, <i>signals from the radar head unit 3 and the vehicle speed sensor 5 which detects the running speed of the vehicle 1 are input into the control unit 4 and the running mode of the vehicle 1 is determined by the control unit 4 and shown by the headup display 6.</i> When it is determined that the forward object is an obstruction for the vehicle 1 to clear, the alarm 7 operates and the <i>vehicle control device 8</i> automatically causes brakes 8a of the vehicle 1 to operate to decelerate vehicle 1.”</p> <p>E.g., FIG. 3.</p>

Limitation of '781 Patent Claim 31	PCT Publication No. WO 96/02853 (Tonkin)	U.S. Patent No. 5,708,584 (Doi et al.)
	<p><i>by the Minister of Transport, in which a vehicle will stop when the brakes are applied. Accordingly, by knowing the velocity of the subject vehicle 16 for example preferably using the radar ground sensing system described herein, which provides therefore a true ground speed, or other means in communication with a microprocessor control system and by using a proximity sensor 20 to determine the separation of the subject vehicle 16 from the trailing vehicle 18 a safety envelope can be created behind the subject vehicle 16. Intrusion in the envelope by the trailing vehicle 18 causes an initial level of lamps 13 in array 12 to be lit."</i></p> <p>E.g., page 17, lines 7 to 25, "<i>Thus a warning system has been described using a ground speed sensor for a subject vehicle 16 coupled by a microprocessor with a proximity sensor 20. In a more sophisticate [sic] version, proximity sensor 20 could be a radar device described herein for measuring velocity and could therefore be used to measure the relative velocity of a subject vehicle 16 and trailing vehicle 18. By knowing the closing speed of the trailing vehicle 18 predetermined values could be used to trigger warning displays if the closing speed is too great. For example, a look-up table or database could again be provided for unsafe closing speeds. This look-up table might again be varied according to the velocity of the subject vehicle 16 in a similar manner to the safe stopping distance, or safety envelope distance. Therefore, whilst the safety envelope distance at 30mph is 25 metres, if the trailing vehicle is closing too rapidly, say, a difference in speed of 30mph, then the warning signal could be activated even when the trailing vehicle 18 is 50 metres behind the subject vehicle 16."</i></p>	

Limitation of '781 Patent Claim 32	PCT Publication No. WO 96/02853 (Tonkin)	U.S. Patent No. 5,708,584 (Doi et al.)
32. Apparatus for optimizing operation of a vehicle according to claim 31 wherein:	See claim 31 claim chart, at page A-230.	See claim 31 claim chart, at page A-230.
said at least one sensor further includes a windshield wiper sensor for indicating whether a windshield wiper of said vehicle is activated; and	E.g., page 18, lines 9 to 13, "The information regarding the weather might be obtained for example by enabling the warning system controller to ascertain if the windscreen wipers are in use or have been in use recently due to rain (and not used with a water spray to clean the windscreen)."	
said memory subsystem further storing a second vehicle speed/stopping distance table;	<p>E.g., page 3, lines 25 to 32, "The size of the enhanced safe distance and enlarged safety envelope will generally be predetermined so as to correspond to typical parameters appropriate for driving under adverse road conditions. <i>These parameters may for example be stored in a look up table</i> allowing the parameters to be determined from the signals received by the controller together with the parameters defining the normal safety envelope."</p> <p>E.g., page 16, lines 2 to 21, "The control system is designed to activate display 12 to provide a warning signal to a driver of the trailing vehicle when the trailing vehicle 18 when the trailing vehicle is closing too rapidly on the subject vehicle 16 for example, alternately a warning signal is displayed when the trailing vehicle 18 is too close to the subject vehicle 16. Even if they are travelling at the same speed for example, <u><i>there are known safe stopping distances such as those published by the Minister of Transport</i></u>, in which a vehicle will stop when the brakes are applied. Accordingly, by knowing the velocity of the subject vehicle 16 for example preferably using the radar ground sensing system described herein, which provides therefore a true ground speed, or other means in communication with a microprocessor control system and by using a proximity sensor 20 to determine the separation of the subject vehicle 16 from the trailing vehicle 18 a safety envelope</p>	

Limitation of '781 Patent Claim 32	PCT Publication No. WO 96/02853 (Tonkin)	U.S. Patent No. 5,708,584 (Dot et al.)
	<p>can be created behind the subject vehicle 16. Intrusion in the envelope by the trailing vehicle 18 causes an initial level of lamps 13 in array 12 to be lit.”</p> <p>E.g., page 17, lines 7 to 25, “Thus a warning system has been described using a ground speed sensor for a subject vehicle 16 coupled by a microprocessor with a proximity sensor 20. In a more sophisticate [sic] version, proximity sensor 20 could be a radar device described herein for measuring velocity and could therefore be used to measure the relative velocity of a subject vehicle 16 and trailing vehicle 18. By knowing the closing speed of the trailing vehicle 18 predetermined values could be used to trigger warning displays if the closing speed is too great. <i>For example, a look-up table or database could again be provided for unsafe closing speeds. This look-up table might again be varied according to the velocity of the subject vehicle 16 in a similar manner to the safe stopping distance, or safety envelope distance.</i> Therefore, whilst the safety envelope distance at 30mph is 25 metres, if the trailing vehicle is closing too rapidly, say, a difference in speed of 30mph, then the warning signal could be activated even when the trailing vehicle 18 is 50 metres behind the subject vehicle 16.”</p>	
<p>if said windshield wiper sensor indicates that said windshield wiper is deactivated, said processor subsystem determining whether to activate said vehicle proximity alarm circuit based upon data received from said radar detector, said road speed sensor and said first vehicle speed/stopping distance table stored in said memory subsystem;</p>	<p>E.g., page 2, line 29 to Page 3, line 3, “The system may comprise means for warning that the subject vehicle is stationary. The system can further comprise means for providing warning of different levels of deceleration of the subject vehicle. The warning means can comprise an orange light display for the relative speed and/or relative separation conditions and a red light display for the vehicle stationary and/or levels of deceleration conditions. The relative separation and/or relative speed warning may be overridden by the level of deceleration warning.”</p> <p>E.g., page 3, lines 25 to 32, “The size of the enhanced safe distance and enlarged safety envelope will generally</p>	<p>E.g., col. 2, lines 58 to 62, “The radar head unit 3 emits a pulse laser beam (as a radar wave) forward of the vehicle 1 from the source and receives reflected light beam reflected by a forward object in the way such as a vehicle, thereby measuring the distance from the vehicle 1 to the forward object.”</p> <p>E.g., col. 2, line 66 to col. 3, line 7, “As shown in FIG. 2, <i>signals from the radar head unit 3 and the vehicle speed sensor 5 which detects the running speed of the vehicle 1 are input into the control unit 4 and the running mode of the vehicle 1 is determined by the control unit 4 and shown by the headup display 6.</i> When it is determined that the forward object is an</p>

Limitation of '781 Patent Claim 32	PCT Publication No. WO 96/02853 (Tonkin)	U.S. Patent No. 5,708,584 (Dot et al.)
	<p>be predetermined so as to correspond to typical parameters appropriate for driving under adverse road conditions. <i>These parameters may for example be stored in a look up table allowing the parameters to be determined from the signals received by the controller together with the parameters defining the normal safety envelope.</i>"</p> <p>E.g., page 16, lines 2 to 21, "The control system is designed to activate display 12 to provide a warning signal to a driver of the trailing vehicle when the trailing vehicle 18 when the trailing vehicle is closing too rapidly on the subject vehicle 16 for example, alternately a warning signal is displayed when the trailing vehicle 18 is too close to the subject vehicle 16. Even if they are travelling at the same speed for example, <i>there are known safe stopping distances such as those published by the Minister of Transport, in which a vehicle will stop when the brakes are applied.</i> Accordingly, by knowing the velocity of the subject vehicle 16 for example preferably using the radar ground sensing system described herein, which provides therefore a true ground speed, or other means in communication <i>with a microprocessor control system and by using a proximity sensor 20 to determine the separation of the subject vehicle 16 from the trailing vehicle 18 a safety envelope can be created behind the subject vehicle 16. Intrusion in the envelope by the trailing vehicle 18 causes an initial level of lamps 13 in array 12 to be lit.</i>"</p> <p>E.g., page 17, lines 7 to 25, "<i>Thus a warning system has been described using a ground speed sensor for a subject vehicle 16 coupled by a microprocessor with a proximity sensor 20.</i> In a more sophisticate [sic] version, proximity sensor 20 could be a radar device described herein for measuring velocity and could therefore be used to measure the relative velocity of a subject vehicle 16 and trailing vehicle 18. By knowing the closing speed of the trailing vehicle 18 predetermined</p>	<p>obstruction for the vehicle 1 to clear, the alarm 7 operates and the <i>vehicle control device</i> 8 automatically causes brakes 8a of the vehicle 1 to operate to decelerate vehicle 1."</p> <p>E.g., FIG. 3.</p>



Limitation of '781 Patent Claim 32	PCT Publication No. WO 96/02853 (Tonkin)	U.S. Patent No. 5,708,584 (Doi et al.)
	<p>values could be used to trigger warning displays if the closing speed is too great. For example, a look-up table or database could again be provided for unsafe closing speeds. This look-up table might again be varied according to the velocity of the subject vehicle 16 in a similar manner to the safe stopping distance, or safety envelope distance. Therefore, whilst the safety envelope distance at 30mph is 25 metres, if the trailing vehicle is closing too rapidly, say, a difference in speed of 30mph, then the warning signal could be activated even when the trailing vehicle 18 is 50 metres behind the subject vehicle 16.”</p>	
<p>if said windshield wiper sensor indicates that said windshield wiper is activated, said processor subsystem determining whether to activate said vehicle proximity alarm circuit based upon data received from said radar detector, said road speed sensor and said second vehicle speed/stopping distance table stored in said memory subsystem.</p>	<p>E.g., page 18, lines 16 to 19, “Thus, safe stopping distances can be adjusted for prevailing weather conditions, again by providing stored values according to weather and possibly for different severities of poor weather.”</p>	

**12. Claims 2, 4, and 5 are Obvious in View of the Combination of Jurgen, Saturn '452, and Chasteen**

Limitation of '781 Patent Claim 2	Automotive Electronics Handbook (Jurgen)	U.S. Patent No. 5,477,452 (Saturn '452)	U.S. Patent No. 4,901,701 (Chasteen)
<p>2. Apparatus for optimizing operation of a vehicle according to claim 1 wherein said processor subsystem further comprises:</p>	<p>See claim 1 claim chart, at page A-3.</p>	<p>See claim 1 claim chart, at page A-3.</p>	<p>E.g., col. 1, lines 9 to 13, "The present invention relates generally to two-stroke operating cycle engines and, more particularly, to a two stroke engine fuel injection system and control system therefor which are adapted for extreme weather conditions."</p> <p>E.g., col. 2, lines 2 to 17, "Small, two-cycle engines are especially subject to malfunction under variable operating conditions such as changes in sea level, with associated barometric changes and changes in ambient air temperature. Many machines such as snowmobiles, snowblowers, dirt bikes, etc., are operated in such widely variable operating conditions. In view of the costs associated with engine modification for sensors' need for electronic control of fuel injectors and in view of the fact that the engine parameters which are critical to control of fuel injectors for two-cycle engines were not, prior to the present invention, understood in the art, a successful electronically-controlled fuel injection system for small, two-cycle engines which are subject to extremes in operating conditions has not been developed in the prior art."</p>
<p>means for determining when road speed for said vehicle is increasing;</p>	<p>E.g., page 7.6, "There are several applications for rotational speed sensing. First it is necessary to monitor engine speed. This information is used for transmission control, engine control, cruise control, and possibly for a tachometer. Electronics and electronic sensing in the automobile were brought about by the need for higher efficiency engines, better fuel economy, increased power and</p>		

Limitation of '781 Patent Claim 2	Automotive Electronics Handbook (Jurgen)	U.S. Patent No. 5,477,452 (Saturn '452)	U.S. Patent No. 4,901,701 (Chasteen)
	<p>performance, and lower emissions. Second, <i>wheel speed sensing is required</i> for use in transmissions, cruise control, speedometers, antilock brake systems (ABS), traction control (ASR), variable ratio power steering assist, four-wheel steering, and possibly in inertial navigation and air bag deployment applications.”</p> <p>E.g., page 7.8, “In electronic transmission applications, <i>information from the road and engine speed sensors</i>, as well as torque data and throttle position are required for the MCU to select the optimum gear ratio.”</p>		
<p>means for determining when throttle position for said vehicle is increasing; and</p>	<p>E.g., page 12.18, “To control the idle speed, the ECU uses inputs from the <i>throttle position sensor</i>, air conditioning, automatic transmission, power steering, charging system, engine RPM, and vehicle speed.”</p> <p>E.g., page 12.21, “The electronic injection unit also houses the <i>throttle position sensor</i> and, in some cases, an inlet air temperature sensor which provides operating condition information to the ECU.”</p>	<p>E.g., col. 7, lines 13 to 21, “Throttle position “%T” is checked at block 515 against a closed position threshold K3. Closed throttle is indicative of vehicle coast, a state of operation wherein the engine is not imparting torque to the drive wheels and thus does not necessitate an upshift. Closed throttle may also be indicative of the operator purposefully using the drivetrain to decelerate the vehicle. <i>Therefore, where a closed throttle is detected</i>, control bypasses the upshift threshold steps 530 and proceeds with execution of block 552.”</p> <p>E.g., FIG. 1:</p>	<p>E.g., col. 9, lines 3 to 8, “These sensors may include a battery voltage sensor 134, an air temperature sensor 136, an engine temperature sensor 138, an engine speed sensor 140, an ignition timing sensor 142, a barometric pressure sensor 144, and <i>a throttle position sensor 146.</i>”</p> <p>E.g., FIG. 1</p>

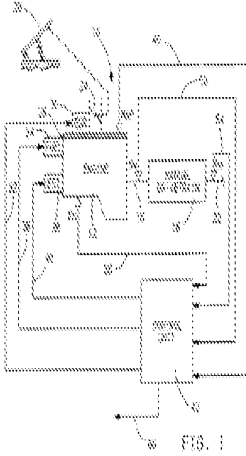
Limitation of '781 Patent Claim 2	Automotive Electronics Handbook (Jurgen)	U.S. Patent No. 5,477,452 (Saturn '452)	U.S. Patent No. 4,901,701 (Chasteen)
			
<p>means for comparing manifold pressure to said manifold pressure set point;</p>	<p>E.g., page 12.1, “The electronic engine control system consists of <i>sensing devices which continuously measure the operating conditions of the engine, an electronic control unit (ECU) which evaluates the sensor inputs</i> using data tables and calculations and determines the output to the actuating devices, and actuating devices which are commanded by the ECU to perform an action in response to the sensor inputs.”</p> <p>E.g., page 22.6, “During the entire operating time of the vehicle, <i>the ECUs are constantly supervising the sensors they are connected to.</i>”</p> <p>E.g., page 13.4, “On the functional side, the hardware configuration can be divided into power supply, input signal transfer circuits, output stages, and <i>microcontroller</i>, including peripheral components and monitoring and safety circuits (Fig. 13.1).”</p>		

Limitation of '781 Patent Claim 2	Automotive Electronics Handbook (Jurgen)	U.S. Patent No. 5,477,452 (Saturn '452)	U.S. Patent No. 4,901,701 (Chasteen)
<p>said processor subsystem activating said fuel overinjection notification circuit if both road speed and throttle position for said vehicle are increasing and manifold pressure for said vehicle is above said manifold pressure set point.</p>	<p>E.g., page 12.4, "During coasting and braking, fuel consumption can be further reduced by shutting off the fuel until the engine speed decreases to slightly higher than the set idle speed. <i>The ECU determines when fuel shutoff can occur by evaluating the throttle position, engine RPM, and vehicle speed.</i>"</p> <p>E.g., page 12.14, "Using the inputs of engine RPM and vehicle speed to the electronic control unit, thresholds can be established for limiting these variables with fuel cutoff. <i>When the maximum speed is achieved, the fuel injectors are shut off.</i> When the speed decreases below the threshold, fuel injection resumes."</p>		<p>E.g., col. 9, lines 1 to 8, "The electronic control assembly comprises a number of sensors having sensor outputs which are provided to the CPU 130 through interface circuitry 132. These sensors may include a battery voltage sensor 134, an air temperature sensor 136, an engine temperature sensor 138, an engine speed sensor 140, an ignition timing sensor 142, a barometric pressure sensor 144, and a throttle position sensor 146."</p> <p>E.g., col. 9, lines 48 to 55, "The CPU 130 receives and processes the signals from the various sensors described above and generates control signals which are used to control fuel pump speed, to maintain the speed of operation of the fuel pump at a rate which provides a pressure in the circulation conduit portion immediately downstream therefrom which is approximately equal to the preset maximum pressure of the pressure regulator 114."</p> <p>E.g., col. 11, lines 22 to 33, "As indicated at 303 the CPU determines from the reading taken at 302 whether or not the engine RPM is greater than 0. If engine RPM is greater than 0, the CPU next makes the determination from the throttle position reading of 302 whether or not the throttle position is greater than a predetermined amount, such as 20°, as indicated in block 304. If throttle position is less than 20°, the CPU decision-making process returns to block 302. If the throttle position is greater than the predetermined amount and RPM = 0, the CPU provides a control command to the engine fuel injector(s) to prime the engine."</p> <p>E.g., August 6, 1998 Office Action, "Chasteen discloses the sensors as discussed for sensing the signals and a processor and compare manifold pressure for activating the fuel injection. Chasteen</p>

Limitation of '781 Patent Claim 2	Automotive Electronics Handbook (Jurgen)	U.S. Patent No. 5,477,452 (Saturn '452)	U.S. Patent No. 4,901,701 (Chasteen)
			discloses the speed (RPM) and throttle position are determined to be greater than 0 (increasing) and the CPU provides a control command to the engine fuel injector to prime the engine (See column 11, lines 22-33) therefore on [sic] would consider increasing and decreasing the speed and throttle for adjusting the fuel injector for supplying fuel to the engine.”

Limitation of '781 Patent Claim 4	Automotive Electronics Handbook (Jurgen)	U.S. Patent No. 5,477,452 (Saturn '452)	U.S. Patent No. 4,901,701 (Chasteen)
<p>4. Apparatus for optimizing operation of a vehicle according to claim 1 wherein said processor subsystem further comprises:</p>	<p>See claim 1 claim chart, at page A-3.</p>	<p>See claim 1 claim chart, at page A-3.</p>	<p>E.g., col. 1, lines 9 to 13, "The present invention relates generally to two-stroke operating cycle engines and, more particularly, to a two stroke engine fuel injection system and control system therefor which are adapted for extreme weather conditions."</p> <p>E.g., col. 2, lines 2 to 17, "Small, two-cycle engines are especially subject to malfunction under variable operating conditions such as changes in sea level, with associated barometric changes and changes in ambient air temperature. Many machines such as snowmobiles, snowblowers, dirt bikes, etc., are operated in such widely variable operating conditions. In view of the costs associated with engine modification for sensors' need for electronic control of fuel injectors and in view of the fact that the engine parameters which are critical to control of fuel injectors for two-cycle engines were not, prior to the present invention, understood in the art, a successful electronically-controlled fuel injection system for small, two-cycle engines which are subject to extremes in operating conditions has not been developed in the prior art."</p>
<p>means for determining when road speed for said vehicle is decreasing;</p>	<p>E.g., page 7.6, "There are several applications for rotational speed sensing. First it is necessary to monitor engine speed. This information is used for transmission control, engine control, cruise control, and possibly for a tachometer. Electronics and electronic sensing in the automobile were brought about by the need for higher efficiency engines, better fuel economy, increased power and performance, and lower emissions. Second, <i>wheel speed sensing is required</i> for use in transmissions, cruise control, speedometers,</p>		

Limitation of '781 Patent Claim 4	Automotive Electronics Handbook (Jurgen)	U.S. Patent No. 5,477,452 (Saturn '452)	U.S. Patent No. 4,901,701 (Chasteen)
	<p>antilock brake systems (ABS), traction control (ASR), variable ratio power steering assist, four-wheel steering, and possibly in inertial navigation and air bag deployment applications.”</p> <p>E.g., page 7.8, “In electronic transmission applications, <i>information from the road and engine speed sensors</i>, as well as torque data and throttle position are required for the MCU to select the optimum gear ratio.”</p>		
<p>means for determining when throttle position for said vehicle is increasing;</p>	<p>E.g., page 12.18, “To control the idle speed, the ECU uses inputs from the <i>throttle position sensor</i>, air conditioning, automatic transmission, power steering, charging system, engine RPM, and vehicle speed.”</p> <p>E.g., page 12.21, “The electronic injection unit also houses the <i>throttle position sensor</i> and, in some cases, an inlet air temperature sensor which provides operating condition information to the ECU.”</p>	<p>E.g., col. 7, lines 13 to 21, “Throttle position “%T” is checked at block 515 against a closed position threshold K3. Closed throttle is indicative of vehicle coast, a state of operation wherein the engine is not imparting torque to the drive wheels and thus does not necessitate an upshift. Closed throttle may also be indicative of the operator purposefully using the drivetrain to decelerate the vehicle. <i>Therefore, where a closed throttle is detected</i>, control bypasses the upshift threshold steps 530 and proceeds with execution of block 552.”</p> <p>E.g., FIG. 1:</p>	<p>E.g., col. 9, lines 3 to 8, “These sensors may include a battery voltage sensor 134, an air temperature sensor 136, an engine temperature sensor 138, an engine speed sensor 140, an ignition timing sensor 142, a barometric pressure sensor 144, and a <i>throttle position sensor 146</i>.”</p> <p>E.g., FIG. 1</p>

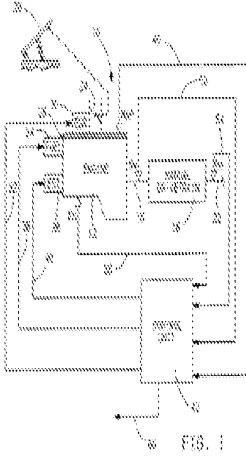

Limitation of '781 Patent Claim 4	Automotive Electronics Handbook (Jurgen)	U.S. Patent No. 5,477,452 (Saturn '452)	U.S. Patent No. 4,901,701 (Chasteen)
			
<p>means for determining when manifold pressure for said vehicle is increasing; and</p>	<p>E.g., page 2.5, “Automotive specification and testing guidelines have been developed and published by the Society of Automotive Engineers (SAE) specifically for <i>manifold absolute pressure (MAP) sensors</i>.”</p> <p>E.g., page 2.7, “Manifold absolute pressure (MAP) is used as an input to fuel and ignition control in internal combustion engine control systems. <i>The speed-density system that uses the MAP sensor</i> has been preferred over mass air flow (MAF) control because it's less expensive, but stricter emission standards are causing more manufacturers to use mass air flow for future models.”</p>		
<p>means for determining when engine speed for said vehicle is decreasing;</p>	<p>E.g., page 7.6, “There are several applications for rotational speed sensing. <i>First it is necessary to monitor engine speed</i>. This information is used for transmission control, engine control, cruise control, and possibly for a tachometer. Electronics and electronic sensing in the</p>	<p>E.g., col. 2, lines 42 to 44, “Control unit 42 receives inputs required by the present embodiment including manifold absolute pressure (MAP), on line 46, <i>engine speed (Ne)</i> on line 50 and output speed (No) on line 54.”</p> <p>E.g., col. 6, lines 55 to 60, “First, <i>engine speed</i></p>	<p>E.g., col. 9, lines 3 to 8, “These sensors may include a battery voltage sensor 134, an air temperature sensor 136, an engine temperature sensor 138, <i>an engine speed sensor 140</i>, an ignition timing sensor 142, a barometric pressure sensor 144, and a throttle position sensor 146.”</p>

Limitation of '781 Patent Claim 4	Automotive Electronics Handbook (Jurgen)	U.S. Patent No. 5,477,452 (Saturn '452)	U.S. Patent No. 4,901,701 (Chasteen)
	<p>automobile were brought about by the need for higher efficiency engines, better fuel economy, increased power and performance, and lower emissions. Second, wheel speed sensing is required for use in transmissions, cruise control, speedometers, antilock brake systems (ABS), traction control (ASR), variable ratio power steering assist, four-wheel steering, and possibly in inertial navigation and air bag deployment applications.”</p> <p>E.g., page 7.8, “In electronic transmission applications, <i>information from the road and engine speed sensors</i>, as well as torque data and throttle position are required for the MCU to select the optimum gear ratio.”</p>	<p><i>Ne is checked at block 511 to determine if it exceeds a predetermined maximum allowable engine speed threshold K1.</i> If the threshold is exceeded then an upshift is required regardless of the value of UTR and control is therefore passed via line 560 to block 542 where the shift light flag is set to one (SL FLAG=1). If the threshold at block 511 is not exceeded, decision block 512 is encountered.”</p> <p>E.g., FIG. 1:</p>	<p>E.g., FIG. 1</p>
<p>said processor subsystem activating said fuel overinjection notification circuit if both throttle position and manifold pressure for said vehicle are increasing and road speed and engine speed for said vehicle are decreasing.</p>	<p>E.g., page 12.4, “During coasting and braking, fuel consumption can be further reduced by shutting off the fuel until the engine speed decreases to slightly higher than the set idle speed. <i>The ECU determines when fuel shutoff can occur by evaluating the throttle position, engine RPM, and vehicle speed.</i>”</p> <p>E.g., page 12.14, “Using the inputs of engine RPM and vehicle speed to the electronic control unit, thresholds can be</p>		<p>E.g., col. 9, lines 1 to 8, “The electronic control assembly comprises a number of sensors having sensor outputs which are provided to the CPU 130 through interface circuitry 132. These sensors may include a battery voltage sensor 134, an air temperature sensor 136, an engine temperature sensor 138, an engine speed sensor 140, an ignition timing sensor 142, a barometric pressure sensor 144, and a throttle position sensor 146.”</p> <p>E.g., col. 9, lines 48 to 55, “The CPU 130 receives and processes the signals from the various sensors</p>

Limitation of '781 Patent Claim 4	Automotive Electronics Handbook (Jurgen)	U.S. Patent No. 5,477,452 (Saturn '452)	U.S. Patent No. 4,901,701 (Chasteen)
	<p>established for limiting these variables with fuel cutoff. <i>When the maximum speed is achieved, the fuel injectors are shut off.</i> When the speed decreases below the threshold, fuel injection resumes.”</p>		<p>described above and generates control signals which are used to control fuel pump speed, to maintain the speed of operation of the fuel pump at a rate which provides a pressure in the circulation conduit portion immediately downstream therefrom which is approximately equal to the preset maximum pressure of the pressure regulator 114.”</p> <p>E.g., col. 11, lines 22 to 33, “As indicated at 303 the CPU determines from the reading taken at 302 whether or not the engine RPM is greater than 0. If engine RPM is greater than 0, the CPU next makes the determination from the throttle position reading of 302 whether or not the throttle position is greater than a predetermined amount, such as 20°, as indicated in block 304. If throttle position is less than 20°, the CPU decision-making process returns to block 302. If the throttle position is greater than the predetermined amount and RPM = 0, the CPU provides a control command to the engine fuel injector(s) to prime the engine.”</p> <p>E.g., August 6, 1998 Office Action, “Chasteen discloses the sensors as discussed for sensing the signals and a processor and compare manifold pressure for activating the fuel injection. Chasteen discloses the speed (RPM) and throttle position are determined to be greater than 0 (increasing) and the CPU provides a control command to the engine fuel injector to prime the engine (See column 11, lines 22-33) therefore on [sic] would consider increasing and decreasing the speed and throttle for adjusting the fuel injector for supplying fuel to the engine.”</p>

Limitation of '781 Patent Claim 5	Automotive Electronics Handbook (Jurgen)	U.S. Patent No. 5,477,452 (Saturn '452)	U.S. Patent No. 4,901,701 (Chasteen)
5. Apparatus for optimizing operation of a vehicle according to claim 1 wherein said processor subsystem further comprises:	See claim 1 claim chart, at page A-3.	See claim 1 claim chart, at page A-3.	<p>E.g., col. 1, lines 9 to 13, "The present invention relates generally to two-stroke operating cycle engines and, more particularly, to a two stroke engine fuel injection system and control system therefor which are adapted for extreme weather conditions."</p> <p>E.g., col. 2, lines 2 to 17, "Small, two-cycle engines are especially subject to malfunction under variable operating conditions such as changes in sea level, with associated barometric changes and changes in ambient air temperature. Many machines such as snowmobiles, snowblowers, dirt bikes, etc., are operated in such widely variable operating conditions. In view of the costs associated with engine modification for sensors' need for electronic control of fuel injectors and in view of the fact that the engine parameters which are critical to control of fuel injectors for two-cycle engines were not, prior to the present invention, understood in the art, a successful electronically-controlled fuel injection system for small, two-cycle engines which are subject to extremes in operating conditions has not been developed in the prior art."</p>
means for determining when road speed for said vehicle is increasing;	E.g., page 7.6, "There are several applications for rotational speed sensing. First it is necessary to monitor engine speed. This information is used for transmission control, engine control, cruise control, and possibly for a tachometer. Electronics and electronic sensing in the automobile were brought about by the need for higher efficiency engines, better fuel economy, increased power and performance, and lower		

Limitation of '781 Patent Claim 5	Automotive Electronics Handbook (Jurgen)	U.S. Patent No. 5,477,452 (Saturn '452)	U.S. Patent No. 4,901,701 (Chasteen)
	<p>emissions. Second, <i>wheel speed sensing is required</i> for use in transmissions, cruise control, speedometers, antilock brake systems (ABS), traction control (ASR), variable ratio power steering assist, four-wheel steering, and possibly in inertial navigation and air bag deployment applications.”</p> <p>E.g., page 7.8, “In electronic transmission applications, <i>information from the road and engine speed sensors</i>, as well as torque data and throttle position are required for the MCU to select the optimum gear ratio.”</p>		
<p>means for determining when throttle position for said vehicle is increasing;</p>	<p>E.g., page 12.18, “To control the idle speed, the ECU uses inputs from the <i>throttle position sensor</i>, air conditioning, automatic transmission, power steering, charging system, engine RPM, and vehicle speed.”</p> <p>E.g., page 12.21, “The electronic injection unit also houses the <i>throttle position sensor</i> and, in some cases, an inlet air temperature sensor which provides operating condition information to the ECU.”</p>	<p>E.g., col. 7, lines 13 to 21, “Throttle position “%T” is checked at block 515 against a closed position threshold K3. Closed throttle is indicative of vehicle coast, a state of operation wherein the engine is not imparting torque to the drive wheels and thus does not necessitate an upshift. Closed throttle may also be indicative of the operator purposefully using the drivetrain to decelerate the vehicle. <i>Therefore, where a closed throttle is detected</i>, control bypasses the upshift threshold steps 530 and proceeds with execution of block 552.”</p> <p>E.g., FIG. 1:</p>	<p>E.g., col. 9, lines 3 to 8, “These sensors may include a battery voltage sensor 134, an air temperature sensor 136, an engine temperature sensor 138, an engine speed sensor 140, an ignition timing sensor 142, a barometric pressure sensor 144, and a <i>throttle position sensor 146</i>.”</p> <p>E.g., FIG. 1</p>

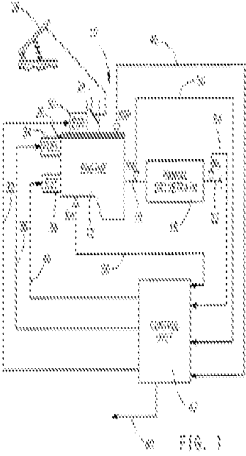
Limitation of '781 Patent Claim 5	Automotive Electronics Handbook (Jurgen)	U.S. Patent No. 5,477,452 (Saturn '452)	U.S. Patent No. 4,901,701 (Chasteen)
			
<p>means for comparing manifold pressure to said manifold pressure set point; and</p>	<p>E.g., page 12.1, “The electronic engine control system consists of <i>sensing devices which continuously measure the operating conditions of the engine, an electronic control unit (ECU) which evaluates the sensor inputs</i> using data tables and calculations and determines the output to the actuating devices, and actuating devices which are commanded by the ECU to perform an action in response to the sensor inputs.”</p> <p>E.g., page 22.6, “During the entire operating time of the vehicle, <i>the ECUs are constantly supervising the sensors they are connected to.</i>”</p> <p>E.g., page 13.4, “On the functional side, the hardware configuration can be divided into power supply, input signal transfer circuits, output stages, and <i>microcontroller</i>, including peripheral components and monitoring and safety</p>		

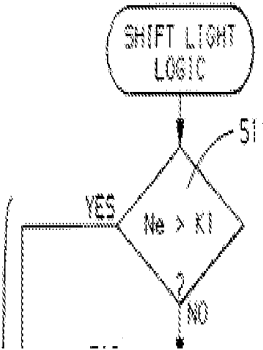
Limitation of '781 Patent Claim 5	Automotive Electronics Handbook (Jurgen)	U.S. Patent No. 5,477,452 (Saturn '452)	U.S. Patent No. 4,901,701 (Chasteen)
	circuits (Fig. 13.1)."		
means for comparing engine speed to said RPM set point;	<p>E.g., page 13.7 to 13.9, "<b>The basic functions of the transmission control are the shift point control</b>, the lockup control, engine torque control during shifting, related safety functions, and diagnostic functions for vehicle service."</p> <p>E.g., page 13.9, "The basic shift point control uses shift maps, which are defined in data in the unit memory. These shift maps are selectable over a wide range. <b>The shift point limitations are made</b>, on the one hand, by the highest admissible engine speed for each application and, on the other hand, <b>by the lowest engine speed that is practical for driving comfort and noise emission. The inputs of the shift point determination are the throttle position, the accelerator pedal position, and the vehicle speed</b> (determined by the transmission output speed)."</p>	<p>E.g., col. 2, lines 52 to 55, "Control unit 42 may be mechanized with a conventional state of the art microcomputer controller including a central processing unit, <b>memory</b> and input-output devices."</p> <p>E.g., col. 6, lines 55 to 60, "First, <b>engine speed <math>N_e</math> is checked at block 511 to determine if it exceeds a predetermined maximum allowable engine speed threshold <math>K1</math></b>. If the threshold is exceeded then an upshift is required regardless of the value of UTR and control is therefore passed via line 560 to block 542 where the shift light flag is set to one (SL FLAG=1). If the threshold at block 511 is not exceeded, decision block 512 is encountered."</p> <p>E.g., FIG. 5:</p> 	<p>E.g., col. 11, lines 22 to 33, "<b>As indicated at 303 the CPU determines from the reading taken at 302 whether or not the engine RPM is greater than 0</b>. If engine RPM is greater than 0, the CPU next makes the determination from the throttle position reading of 302 whether or not the throttle position is greater than a predetermined amount, such as 20°, as indicated in block 304. If throttle position is less than 20°, the CPU decision-making process returns to block 302. <b>If the throttle position is greater than the predetermined amount and RPM = 0, the CPU provides a control command to the engine fuel injector(s) to prime the engine.</b>"</p>
said processor subsystem activating said upshift notification circuit if both road speed and throttle position for said vehicle are increasing, manifold	<p>E.g., page 13.7 to 13.9, "<b>The basic functions of the transmission control are the shift point control</b>, the lockup control, engine torque control during shifting, related safety functions, and diagnostic functions for vehicle service."</p> <p>E.g., page 13.9, "The basic shift point</p>	<p>E.g., col. 2, lines 42 to 55, "Control unit 42 receives inputs required by the present embodiment including manifold absolute pressure (MAP), on line 46, engine speed (<math>N_e</math>) on line 50 and output speed (<math>N_o</math>) on line 54. Knock sensing means <math>K_n</math> are also shown providing signal input via line 56 to control unit 42. <b>Control unit 42 indicates via line 60 the state of an upshift indicator light or equivalent visual display</b></p>	<p>E.g., col. 9, lines 1 to 8, "The electronic control assembly comprises a number of sensors having sensor outputs which are provided to the CPU 130 through interface circuitry 132. These sensors may include a battery voltage sensor 134, an air temperature sensor 136, an engine temperature sensor 138, an engine speed sensor 140, an ignition timing sensor 142, a barometric pressure</p>

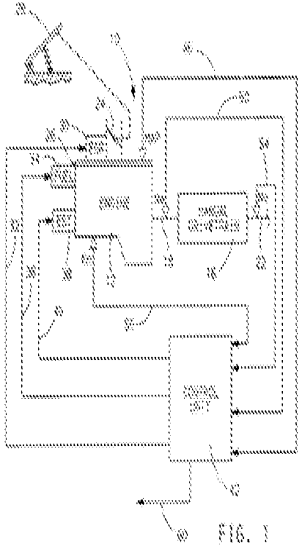
Limitation of '781 Patent Claim 5	Automotive Electronics Handbook (Jurgen)	U.S. Patent No. 5,477,452 (Saturn '452)	U.S. Patent No. 4,901,701 (Chasteen)
<p>pressure for said vehicle is at or below said manifold pressure set point and engine speed for said vehicle is at or above said RPM set point.</p>	<p>control uses shift maps, which are defined in data in the unit memory. These shift maps are selectable over a wide range. <i>The shift point limitations are made</i>, on the one hand, by the highest admissible engine speed for each application and, on the other hand, <i>by the lowest engine speed that is practical for driving comfort and noise emission. The inputs of the shift point determination are the throttle position, the accelerator pedal position, and the vehicle speed</i> (determined by the transmission output speed)."</p>	<p><i>such as is found in conventional instrumentation in a motor vehicle. Line 60 may provide a logic signal to an instrument cluster for further processing or may drive a lamp directly via a power driver in control unit 42.</i> Control unit 42 may be mechanized with a conventional state of the art microcomputer controller including a central processing unit, memory and input-output devices."</p> <p>E.g., col. 3, lines 60 to 65, "Finally, <i>control unit 42 outputs a signal online [sic] 60 as shown in FIG. 1 for indicating the state of the upshift indicator light</i> as well as various other output signals for instrument cluster displays such as vehicle speedometer, oil pressure and coolant temperature for example."</p> <p>E.g., FIG. 1:</p> 	<p>sensor 144, and a throttle position sensor 146."</p> <p>E.g., col. 9, lines 48 to 55, "The CPU 130 receives and processes the signals from the various sensors described above and generates control signals which are used to control fuel pump speed, to maintain the speed of operation of the fuel pump at a rate which provides a pressure in the circulation conduit portion immediately downstream therefrom which is approximately equal to the preset maximum pressure of the pressure regulator 114."</p> <p>E.g., col. 11, lines 22 to 33, "As indicated at 303 the CPU determines from the reading taken at 302 whether or not the engine RPM is greater than 0. If engine RPM is greater than 0, the CPU next makes the determination from the throttle position reading of 302 whether or not the throttle position is greater than a predetermined amount, such as 20°, as indicated in block 304. If throttle position is less than 20°, the CPU decision-making process returns to block 302. If the throttle position is greater than the predetermined amount and RPM = 0, the CPU provides a control command to the engine fuel injector(s) to prime the engine."</p> <p>E.g., August 6, 1998 Office Action, "Chasteen discloses the sensors as discussed for sensing the signals and a processor and compare manifold pressure for activating the fuel injection. Chasteen discloses the speed (RPM) and throttle position are determined to be greater than 0 (increasing) and the CPU provides a control command to the engine fuel injector to prime the engine (See column 11, lines 22-33) therefore on [sic] would consider increasing and decreasing the speed and throttle for adjusting the fuel injector for supplying fuel to</p>



Limitation of '781 Patent Claim 5	Automotive Electronics Handbook (Jurgen)	U.S. Patent No. 5,477,452 (Saturn '452)	U.S. Patent No. 4,901,701 (Chasteen)
			the engine.”

13. Claims 2, 4, 5, 8, 10, 12, and 15 are Obvious in View of the Combination of Jurgen, Toyota '599, and Chasteen

Limitation of '781 Patent Claim 2	Automotive Electronics Handbook (Jurgen)	U.S. Patent No. 4,559,599 (Toyota '599)	U.S. Patent No. 4,901,701 (Chasteen)
<p>2. Apparatus for optimizing operation of a vehicle according to claim 1 wherein said processor subsystem further comprises:</p>	<p>See claim 1 claim chart, at page A-9.</p>	<p>See claim 1 claim chart, at page A-9.</p>	<p>E.g., col. 1, lines 9 to 13, "The present invention relates generally to two-stroke operating cycle engines and, more particularly, to a two stroke engine fuel injection system and control system therefor which are adapted for extreme weather conditions."</p> <p>E.g., col. 2, lines 2 to 17, "Small, two-cycle engines are especially subject to malfunction under variable operating conditions such as changes in sea level, with associated barometric changes and changes in ambient air temperature. Many machines such as snowmobiles, snowblowers, dirt bikes, etc., are operated in such widely variable operating conditions. In view of the costs associated with engine modification for sensors' need for electronic control of fuel injectors and in view of the fact that the engine parameters which are critical to control of fuel injectors for two-cycle engines were not, prior to the present invention, understood in the art, a successful electronically-controlled fuel injection system for small, two-cycle engines which are subject to extremes in operating conditions has not been developed in the prior art."</p>
<p>means for determining when road speed for said vehicle is increasing;</p>	<p>E.g., page 7.6, "There are several applications for rotational speed sensing. First it is necessary to monitor engine speed. This information is used for transmission control, engine control, cruise control, and possibly for a tachometer. Electronics and electronic sensing in the automobile were brought about by the need for higher efficiency</p>		

Limitation of '781 Patent Claim 2	Automotive Electronics Handbook (Jurgen)	U.S. Patent No. 4,559,599 (Toyota '599)	U.S. Patent No. 4,901,701 (Chasteen)
	<p>engines, better fuel economy, increased power and performance, and lower emissions. Second, <i>wheel speed sensing is required</i> for use in transmissions, cruise control, speedometers, antilock brake systems (ABS), traction control (ASR), variable ratio power steering assist, four-wheel steering, and possibly in inertial navigation and air bag deployment applications.”</p> <p>E.g., page 7.8, “In electronic transmission applications, <i>information from the road and engine speed sensors</i>, as well as torque data and throttle position are required for the MCU to select the optimum gear ratio.”</p>		
<p>means for determining when throttle position for said vehicle is increasing; and</p>	<p>E.g., page 12.18, “To control the idle speed, the ECU uses inputs from the <i>throttle position sensor</i>, air conditioning, automatic transmission, power steering, charging system, engine RPM, and vehicle speed.”</p> <p>E.g., page 12.21, “The electronic injection unit also houses the <i>throttle position sensor</i> and, in some cases, an inlet air temperature sensor which provides operating condition information to the ECU.”</p>	<p>E.g., col. 2, lines 23 to 36, “Referring to FIG. 1, the shift indication apparatus with a manual transmission according to the present invention comprises an engine speed sensor 1 for detecting the engine speed and for producing pulse signals of a frequency proportional to the engine speed, a shift position sensor 2 for detecting the shift positions of the transmission, <i>a throttle sensor 3 for detecting the opening degree of the throttle valve by means of, for instance, a potentiometer</i>, an A/D converter 4 for converting analog signals from the throttle valve sensor 3 into digital signals, a microcomputer 5 for performing various calculations in accordance with the different signals from the sensors, and an indicator 10 for indicating the result of the calculations.”</p> <p>E.g., col. 2, lines 52 to 59, “Similarly, the output of <i>the throttle sensor 3</i> is connected through the A/D converter 4 to the input of the I/O port 6 so as to transmit the output signals thereof to the microcomputer 5 through the A/D converter 4 and to store the data corresponding</p>	<p>E.g., col. 9, lines 3 to 8, “These sensors may include a battery voltage sensor 134, an air temperature sensor 136, an engine temperature sensor 138, an engine speed sensor 140, an ignition timing sensor 142, a barometric pressure sensor 144, and <i>a throttle position sensor 146</i>.”</p> <p>E.g., FIG. 1</p>

Limitation of '781 Patent Claim 2	Automotive Electronics Handbook (Jurgen)	U.S. Patent No. 4,559,599 (Toyota '599)	U.S. Patent No. 4,901,701 (Chasteen)
		<p>to the throttle value opening into the RAM 9 after converting from the analog signals into the digital signals.”</p> <p>E.g., FIG. 1:</p>	
<p>means for comparing manifold pressure to said manifold pressure set point;</p>	<p>E.g., page 12.1, “The electronic engine control system consists of <i>sensing devices which continuously measure the operating conditions of the engine, an electronic control unit (ECU) which evaluates the sensor inputs</i> using data tables and calculations and determines the output to the actuating devices, and actuating devices which are commanded by the ECU to perform an action in response to the sensor inputs.”</p>	<p>E.g., col. 2, lines 37 to 42, “The microcomputer 5 further comprises an input/output port (I/O port) 6, a central processing unit (CPU) 7, a read only memory (ROM) 8, and a random access memory (RAM) 9. In the microcomputer 5, there is provided a bus BUS which communicates the I/O port 6 and the CPU 7, ROM 8, and RAM 9.”</p> <p>E.g., col. 3, lines 7 to 20, “The torque data map indicative of torque curves <i>T</i> as shown in FIG. 2 has been stored in the ROM 8 in advance. The fuel consumption rate data map indicative of equal fuel</p>	

Limitation of '781 Patent Claim 2	Automotive Electronics Handbook (Jurgen)	U.S. Patent No. 4,559,599 (Toyota '599)	U.S. Patent No. 4,901,701 (Chasteen)
	<p>E.g., page 22.6, "During the entire operating time of the vehicle, <i>the ECUs are constantly supervising the sensors they are connected to.</i>"</p> <p>E.g., page 13.4, "On the functional side, the hardware configuration can be divided into power supply, input signal transfer circuits, output stages, and <i>microcontroller</i>, including peripheral components and monitoring and safety circuits (Fig. 13.1)."</p>	<p><i>consumption rate curves B as shown in FIG. 3 has been also stored in the ROM 8 in advance. In FIG. 2, each equal torque curve T was prepared by plotting and connecting equal torque points on the graph with respect to the engine speed vs. throttle valve opening.</i></p> <p>In FIG. 3, each fuel consumption rate curve B was prepared by plotting and connecting equal fuel consumption rate points on a graph obtained in advance by experiment data with respect to the engine speed and the torques thus calculated."</p>	
<p>said processor subsystem activating said fuel overinjection notification circuit if both road speed and throttle position for said vehicle are increasing and manifold pressure for said vehicle is above said manifold pressure set point.</p>	<p>E.g., page 12.4, "During coasting and braking, fuel consumption can be further reduced by shutting off the fuel until the engine speed decreases to slightly higher than the set idle speed. <i>The ECU determines when fuel shutoff can occur by evaluating the throttle position, engine RPM, and vehicle speed.</i>"</p> <p>E.g., page 12.14, "Using the inputs of engine RPM and vehicle speed to the electronic control unit, thresholds can be established for limiting these variables with fuel cutoff. <i>When the maximum speed is achieved, the fuel injectors are shut off.</i> When the speed decreases below the threshold, fuel injection resumes."</p>		<p>E.g., col. 9, lines 1 to 8, "The electronic control assembly comprises a number of sensors having sensor outputs which are provided to the CPU 130 through interface circuitry 132. These sensors may include a battery voltage sensor 134, an air temperature sensor 136, an engine temperature sensor 138, an engine speed sensor 140, an ignition timing sensor 142, a barometric pressure sensor 144, and a throttle position sensor 146."</p> <p>E.g., col. 9, lines 48 to 55, "The CPU 130 receives and processes the signals from the various sensors described above and generates control signals which are used to control fuel pump speed, to maintain the speed of operation of the fuel pump at a rate which provides a pressure in the circulation conduit portion immediately downstream thereof which is approximately equal to the preset maximum pressure of the pressure regulator 114."</p> <p>E.g., col. 11, lines 22 to 33, "As indicated at 303 the CPU determines from the reading taken at 302 whether or not the engine RPM is</p>

Limitation of '781 Patent Claim 2	Automotive Electronics Handbook (Jurgen)	U.S. Patent No. 4,559,599 (Toyota '599)	U.S. Patent No. 4,901,701 (Chasteen)
			<p>greater than 0. If engine RPM is greater than 0, the CPU next makes the determination from the throttle position reading of 302 whether or not the throttle position is greater than a predetermined amount, such as 20°, as indicated in block 304. If throttle position is less than 20°, the CPU decision-making process returns to block 302. If the throttle position is greater than the predetermined amount and RPM = 0, the CPU provides a control command to the engine fuel injector(s) to prime the engine.”</p> <p>E.g., August 6, 1998 Office Action, “Chasteen discloses the sensors as discussed for sensing the signals and a processor and compare manifold pressure for activating the fuel injection. Chasteen discloses the speed (RPM) and throttle position are determined to be greater than 0 (increasing) and the CPU provides a control command to the engine fuel injector to prime the engine (See column 11, lines 22-33) therefore on [sic] would consider increasing and decreasing the speed and throttle for adjusting the fuel injector for supplying fuel to the engine.”</p>

Limitation of '781 Patent Claim 4	Automotive Electronics Handbook (Jurgen)	U.S. Patent No. 4,559,599 (Toyota '599)	U.S. Patent No. 4,901,701 (Chasteen)
4. Apparatus for optimizing operation of a vehicle according to claim 1 wherein said processor subsystem further comprises:	See claim 1 claim chart, at page A-9.	See claim 1 claim chart, at page A-9.	<p>E.g., col. 1, lines 9 to 13, "The present invention relates generally to two-stroke operating cycle engines and, more particularly, to a two stroke engine fuel injection system and control system therefor which are adapted for extreme weather conditions."</p> <p>E.g., col. 2, lines 2 to 17, "Small, two-cycle engines are especially subject to malfunction under variable operating conditions such as changes in sea level, with associated barometric changes and changes in ambient air temperature. Many machines such as snowmobiles, snowblowers, dirt bikes, etc., are operated in such widely variable operating conditions. In view of the costs associated with engine modification for sensors' need for electronic control of fuel injectors and in view of the fact that the engine parameters which are critical to control of fuel injectors for two-cycle engines were not, prior to the present invention, understood in the art, a successful electronically-controlled fuel injection system for small, two-cycle engines which are subject to extremes in operating conditions has not been developed in the prior art."</p>
means for determining when road speed for said vehicle is decreasing;	E.g., page 7.6, "There are several applications for rotational speed sensing. First it is necessary to monitor engine speed. This information is used for transmission control, engine control, cruise control, and possibly for a tachometer. Electronics and electronic sensing in the automobile were brought about by the need for higher efficiency engines, better fuel economy, increased power and performance, and lower		

Limitation of '781 Patent Claim 4	Automotive Electronics Handbook (Jurgen)	U.S. Patent No. 4,559,599 (Toyota '599)	U.S. Patent No. 4,901,701 (Chasteen)
	<p>emissions. Second, <i>wheel speed sensing is required</i> for use in transmissions, cruise control, speedometers, antilock brake systems (ABS), traction control (ASR), variable ratio power steering assist, four-wheel steering, and possibly in inertial navigation and air bag deployment applications.”</p> <p>E.g., page 7.8, “In electronic transmission applications, <i>information from the road and engine speed sensors</i>, as well as torque data and throttle position are required for the MCU to select the optimum gear ratio.”</p>		
<p>means for determining when throttle position for said vehicle is increasing;</p>	<p>E.g., page 12.18, “To control the idle speed, the ECU uses inputs from the <i>throttle position sensor</i>, air conditioning, automatic transmission, power steering, charging system, engine RPM, and vehicle speed.”</p> <p>E.g., page 12.21, “The electronic injection unit also houses the <i>throttle position sensor</i> and, in some cases, an inlet air temperature sensor which provides operating condition information to the ECU.”</p>	<p>E.g., col. 2, lines 23 to 36, “Referring to FIG. 1, the shift indication apparatus with a manual transmission according to the present invention comprises an engine speed sensor 1 for detecting the engine speed and for producing pulse signals of a frequency proportional to the engine speed, a shift position sensor 2 for detecting the shift positions of the transmission, <i>a throttle sensor 3 for detecting the opening degree of the throttle valve by means of, for instance, a potentiometer</i>, an A/D converter 4 for converting analog signals from the throttle valve sensor 3 into digital signals, a microcomputer 5 for performing various calculations in accordance with the different signals from the sensors, and an indicator 10 for indicating the result of the calculations.”</p> <p>E.g., col. 2, lines 52 to 59, “Similarly, the output of <i>the throttle sensor 3</i> is connected through the A/D converter 4 to the input of the I/O port 6 so as to transmit the output signals thereof to the microcomputer 5 through the A/D converter 4 and to store the data corresponding to the throttle value opening into the RAM 9 after</p>	<p>E.g., col. 9, lines 3 to 8, “These sensors may include a battery voltage sensor 134, an air temperature sensor 136, an engine temperature sensor 138, an engine speed sensor 140, an ignition timing sensor 142, a barometric pressure sensor 144, and <i>a throttle position sensor 146</i>.”</p> <p>E.g., FIG. 1</p>

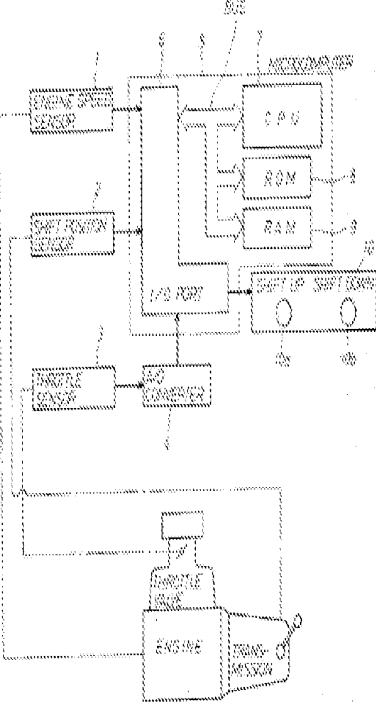

Limitation of '781 Patent Claim 4	Automotive Electronics Handbook (Jurgen)	U.S. Patent No. 4,559,599 (Toyota '599)	U.S. Patent No. 4,901,701 (Chasteen)
		<p>converting from the analog signals into the digital signals.”</p> <p>E.g., FIG. 1:</p> 	
<p>means for determining when manifold pressure for said vehicle is increasing; and</p>	<p>E.g., page 2.5, “Automotive specification and testing guidelines have been developed and published by the Society of Automotive Engineers (SAE) specifically for <i>manifold absolute pressure (MAP) sensors</i>.”</p> <p>E.g., page 2.7, “Manifold absolute pressure (MAP) is used as an input to fuel and ignition control in internal combustion engine control systems. <i>The speed-density system that uses the MAP sensor</i> has been preferred over mass air</p>		

Limitation of '781 Patent Claim 4	Automotive Electronics Handbook (Jurgen)	U.S. Patent No. 4,559,599 (Toyota '599)	U.S. Patent No. 4,901,701 (Chasteen)
	<p>flow (MAF) control because it's less expensive, but stricter emission standards are causing more manufacturers to use mass air flow for future models.”</p>		
<p>means for determining when engine speed for said vehicle is decreasing;</p>	<p>E.g., page 7.6, “There are several applications for rotational speed sensing. <b>First it is necessary to monitor engine speed.</b> This information is used for transmission control, engine control, cruise control, and possibly for a tachometer. Electronics and electronic sensing in the automobile were brought about by the need for higher efficiency engines, better fuel economy, increased power and performance, and lower emissions. Second, wheel speed sensing is required for use in transmissions, cruise control, speedometers, antilock brake systems (ABS), traction control (ASR), variable ratio power steering assist, four-wheel steering, and possibly in inertial navigation and air bag deployment applications.”</p> <p>E.g., page 7.8, “In electronic transmission applications, <b>information from the road and engine speed sensors</b>, as well as torque data and throttle position are required for the MCU to select the optimum gear ratio.”</p>	<p>E.g., col. 2, lines 23 to 36, “Referring to FIG. 1, the shift indication apparatus with a manual transmission according to the present invention comprises <b>an engine speed sensor 1 for detecting the engine speed and for producing pulse signals of a frequency proportional to the engine speed</b>, a shift position sensor 2 for detecting the shift positions of the transmission, <b>a throttle sensor 3 for detecting the opening degree of the throttle valve by means of, for instance, a potentiometer</b>, an A/D converter 4 for converting analog signals from the throttle valve sensor 3 into digital signals, a microcomputer 5 for performing various calculations in accordance with the different signals from the sensors, and an indicator 10 for indicating the result of the calculations.”</p> <p>E.g., col. 2, lines 43 to 48, “<b>The engine speed sensor 1</b> is mounted in a distributor (not shown) and the output of the sensor is connected to the input of the I/O port 6 so as to transmit the output pulses to the microcomputer 5 through the I/O port 6 and to store the data corresponding to the engine speed into the RAM 9.”</p> <p>E.g., FIG. 1:</p>	<p>E.g., col. 9, lines 3 to 8, “These sensors may include a battery voltage sensor 134, an air temperature sensor 136, an engine temperature sensor 138, <b>an engine speed sensor 140</b>, an ignition timing sensor 142, a barometric pressure sensor 144, and a throttle position sensor 146.”</p> <p>E.g., FIG. 1</p>

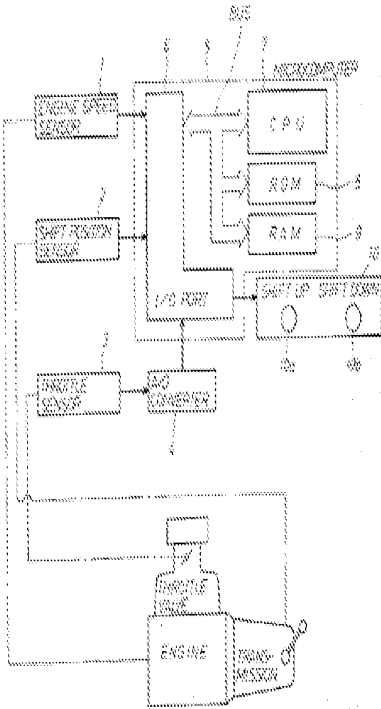
Limitation of '781 Patent Claim 4	Automotive Electronics Handbook (Jurgen)	U.S. Patent No. 4,559,599 (Toyota '599)	U.S. Patent No. 4,901,701 (Chasteen)
			
<p>said processor subsystem activating said fuel overinjection notification circuit if both throttle position and manifold pressure for said vehicle are increasing and road speed and engine speed for said vehicle are decreasing.</p>	<p>E.g., page 12.4, "During coasting and braking, fuel consumption can be further reduced by shutting off the fuel until the engine speed decreases to slightly higher than the set idle speed. <i>The ECU determines when fuel shutoff can occur by evaluating the throttle position, engine RPM, and vehicle speed.</i>"</p> <p>E.g., page 12.14, "Using the inputs of engine RPM and vehicle speed to the electronic control unit, thresholds can be established for limiting these variables with fuel cutoff. <i>When the maximum speed is achieved, the fuel injectors are shut off.</i> When the speed decreases</p>		<p>E.g., col. 9, lines 1 to 8, "The electronic control assembly comprises a number of sensors having sensor outputs which are provided to the CPU 130 through interface circuitry 132. These sensors may include a battery voltage sensor 134, an air temperature sensor 136, an engine temperature sensor 138, an engine speed sensor 140, an ignition timing sensor 142, a barometric pressure sensor 144, and a throttle position sensor 146."</p> <p>E.g., col. 9, lines 48 to 55, "The CPU 130 receives and processes the signals from the various sensors described above and generates control signals which are used to control fuel pump speed, to maintain the speed of operation of the fuel pump at a rate which provides a</p>

Limitation of '781 Patent Claim 4	Automotive Electronics Handbook (Jurgen)	U.S. Patent No. 4,559,599 (Toyota '599)	U.S. Patent No. 4,901,701 (Chasteen)
	<p>below the threshold, fuel injection resumes.”</p>		<p>pressure in the circulation conduit portion immediately downstream therefrom which is approximately equal to the preset maximum pressure of the pressure regulator 114.”</p> <p>E.g., col. 11, lines 22 to 33, “As indicated at 303 the CPU determines from the reading taken at 302 whether or not the engine RPM is greater than 0. If engine RPM is greater than 0, the CPU next makes the determination from the throttle position reading of 302 whether or not the throttle position is greater than a predetermined amount, such as 20°, as indicated in block 304. If throttle position is less than 20°, the CPU decision-making process returns to block 302. If the throttle position is greater than the predetermined amount and RPM = 0, the CPU provides a control command to the engine fuel injector(s) to prime the engine.”</p> <p>E.g., August 6, 1998 Office Action, “Chasteen discloses the sensors as discussed for sensing the signals and a processor and compare manifold pressure for activating the fuel injection. Chasteen discloses the speed (RPM) and throttle position are determined to be greater than 0 (increasing) and the CPU provides a control command to the engine fuel injector to prime the engine (See column 11, lines 22-33) therefore on [sic] would consider increasing and decreasing the speed and throttle for adjusting the fuel injector for supplying fuel to the engine.”</p>

Limitation of '781 Patent Claim 5	Automotive Electronics Handbook (Jurgen)	U.S. Patent No. 4,559,599 (Toyota '599)	U.S. Patent No. 4,901,701 (Chasteen)
5. Apparatus for optimizing operation of a vehicle according to claim 1 wherein said processor subsystem further comprises:	See claim 1 claim chart, at page A-9.	See claim 1 claim chart, at page A-9.	<p>E.g., col. 1, lines 9 to 13, "The present invention relates generally to two-stroke operating cycle engines and, more particularly, to a two stroke engine fuel injection system and control system therefor which are adapted for extreme weather conditions."</p> <p>E.g., col. 2, lines 2 to 17, "Small, two-cycle engines are especially subject to malfunction under variable operating conditions such as changes in sea level, with associated barometric changes and changes in ambient air temperature. Many machines such as snowmobiles, snowblowers, dirt bikes, etc., are operated in such widely variable operating conditions. In view of the costs associated with engine modification for sensors' need for electronic control of fuel injectors and in view of the fact that the engine parameters which are critical to control of fuel injectors for two-cycle engines were not, prior to the present invention, understood in the art, a successful electronically-controlled fuel injection system for small, two-cycle engines which are subject to extremes in operating conditions has not been developed in the prior art."</p>
means for determining when road speed for said vehicle is increasing;	E.g., page 7.6, "There are several applications for rotational speed sensing. First it is necessary to monitor engine speed. This		

Limitation of '781 Patent Claim 5	Automotive Electronics Handbook (Jurgen)	U.S. Patent No. 4,559,599 (Toyota '599)	U.S. Patent No. 4,901,701 (Chasteen)
	<p>information is used for transmission control, engine control, cruise control, and possibly for a tachometer. Electronics and electronic sensing in the automobile were brought about by the need for higher efficiency engines, better fuel economy, increased power and performance, and lower emissions. Second, <i>wheel speed sensing is required</i> for use in transmissions, cruise control, speedometers, antilock brake systems (ABS), traction control (ASR), variable ratio power steering assist, four-wheel steering, and possibly in inertial navigation and air bag deployment applications.”</p> <p>E.g., page 7.8, “In electronic transmission applications, <i>information from the road and engine speed sensors</i>, as well as torque data and throttle position are required for the MCU to select the optimum gear ratio.”</p>		
<p>means for determining when throttle position for said vehicle is increasing;</p>	<p>E.g., page 12.18, “To control the idle speed, the ECU uses inputs from the <i>throttle position sensor</i>, air conditioning, automatic transmission, power steering, charging system, engine RPM, and vehicle speed.”</p> <p>E.g., page 12.21, “The electronic injection unit also houses the <i>throttle position sensor</i> and, in some cases, an inlet air temperature sensor which provides operating condition</p>	<p>E.g., col. 2, lines 23 to 36, “Referring to FIG. 1, the shift indication apparatus with a manual transmission according to the present invention comprises an engine speed sensor 1 for detecting the engine speed and for producing pulse signals of a frequency proportional to the engine speed, a shift position sensor 2 for detecting the shift positions of the transmission, <i>a throttle sensor 3 for detecting the opening degree of the throttle valve by means of, for instance, a potentiometer</i>, an A/D converter 4 for converting analog signals from the throttle valve sensor 3 into digital signals, a microcomputer 5 for performing various calculations in</p>	<p>E.g., col. 9, lines 3 to 8, “These sensors may include a battery voltage sensor 134, an air temperature sensor 136, an engine temperature sensor 138, an engine speed sensor 140, an ignition timing sensor 142, a barometric pressure sensor 144, and <i>a throttle position sensor 146.</i>”</p> <p>E.g., FIG. 1</p>

Limitation of '781 Patent Claim 5	Automotive Electronics Handbook (Jurgen)	U.S. Patent No. 4,559,599 (Toyota '599)	U.S. Patent No. 4,901,701 (Chasteen)
	<p>information to the ECU.”</p>	<p>accordance with the different signals from the sensors, and an indicator 10 for indicating the result of the calculations.”</p> <p>E.g., col. 2, lines 52 to 59, “Similarly, the output of <i>the throttle sensor 3</i> is connected through the A/D converter 4 to the input of the I/O port 6 so as to transmit the output signals thereof to the microcomputer 5 through the A/D converter 4 and to store the data corresponding to the throttle value opening into the RAM 9 after converting from the analog signals into the digital signals.”</p> <p>E.g., FIG. 1:</p>	
<p>means for comparing manifold pressure to said manifold pressure set point; and</p>	<p>E.g., page 12.1, “The electronic engine control system consists of <i>sensing devices which continuously</i></p>		

Limitation of '781 Patent Claim 5	Automotive Electronics Handbook (Jurgen)	U.S. Patent No. 4,559,599 (Toyota '599)	U.S. Patent No. 4,901,701 (Chasteen)
	<p><i>measure the operating conditions of the engine, an electronic control unit (ECU) which evaluates the sensor inputs using data tables and calculations and determines the output to the actuating devices, and actuating devices which are commanded by the ECU to perform an action in response to the sensor inputs.</i></p> <p>E.g., page 22.6, "During the entire operating time of the vehicle, <i>the ECUs are constantly supervising the sensors they are connected to.</i>"</p> <p>E.g., page 13.4, "On the functional side, the hardware configuration can be divided into power supply, input signal transfer circuits, output stages, and <i>microcontroller</i>, including peripheral components and monitoring and safety circuits (Fig. 13.1)."</p>		
<p>means for comparing engine speed to said RPM set point;</p>	<p>E.g., page 13.7 to 13.9, "<i>The basic functions of the transmission control are the shift point control, the lockup control, engine torque control during shifting, related safety functions, and diagnostic functions for vehicle service.</i>"</p> <p>E.g., page 13.9, "The basic shift point control uses shift maps, which are defined in data in the unit memory. These shift maps are selectable over a wide range. <i>The</i></p>	<p>E.g., col. 2, lines 37 to 42, "The microcomputer 5 further comprises an input/output port (I/O port) 6, a central processing unit (CPU) 7, a <i>read only memory (ROM) 8, and a random access memory (RAM) 9.</i> In the microcomputer 5, there is provided a bus BUS which communicates the I/O port 6 and the CPU 7, <i>ROM 8, and RAM 9.</i>"</p> <p>E.g., col. 3, lines 7 to 20, "<i>The torque data map indicative of torque curves T as shown in FIG. 2 has been stored in the ROM 8 in advance. The fuel consumption rate data map indicative of equal fuel consumption rate curves B as shown in FIG. 3 has</i></p>	<p>E.g., col. 11, lines 22 to 33, "<i>As indicated at 303 the CPU determines from the reading taken at 302 whether or not the engine RPM is greater than 0.</i> If engine RPM is greater than 0, the CPU next makes the determination from the throttle position reading of 302 whether or not the throttle position is greater than a predetermined amount, such as 20°, as indicated in block 304. If throttle position is less than 20°, the CPU decision-making process</p>

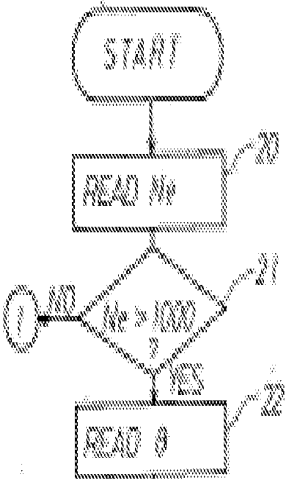

Limitation of '781 Patent Claim 5	Automotive Electronics Handbook (Jurgen)	U.S. Patent No. 4,559,599 (Toyota '599)	U.S. Patent No. 4,901,701 (Chasteen)
	<p><i>shift point limitations are made, on the one hand, by the highest admissible engine speed for each application and, on the other hand, by the lowest engine speed that is practical for driving comfort and noise emission. The inputs of the shift point determination are the throttle position, the accelerator pedal position, and the vehicle speed (determined by the transmission output speed).</i></p>	<p><i>been also stored in the ROM 8 in advance. In FIG. 2, each equal torque curve T was prepared by plotting and connecting equal torque points on the graph with respect to the engine speed vs. throttle valve opening. In FIG. 3, each fuel consumption rate curve B was prepared by plotting and connecting equal fuel consumption rate points on a graph obtained in advance by experiment data with respect to the engine speed and the torques thus calculated.</i></p> <p>E.g., col. 3, lines 44 to 61, <i>"In this case, as shown in FIG. 4, the operation of a main routine is started at a predetermined timing, e.g. periodical timing pulses from a timer (not shown) and the detection of the engine speed <math>N_e</math> from the sensor 1 is carried out and it is stored into the RAM 9 at the step 20. Then, the engine speed <math>N_e</math> is read from the RAM 9 and it is compared with a predetermined number <math>N (=1000 \text{ rpm})</math> to determine whether or not the <math>N_e</math> exceeds the value 1000 at the step 21. If the result of the decision is YES, the next step 22 is executed. That is, in the step 22, the reading in of the opening of the throttle valve is performed through the throttle sensor 3 and the A/D converter 4. In the above case, if the result of the decision in step 21 is NO, the main routine is terminated by determining that the shift operation is not necessary and the engine speed <math>N_e</math> is read again at the predetermined timing and now the operation returns to the step 20."</i></p> <p>E.g., Figure 4:</p>	<p>returns to block 302. <i>If the throttle position is greater than the predetermined amount and <math>RPM = 0</math>, the CPU provides a control command to the engine fuel injector(s) to prime the engine."</i></p>

Limitation of '781 Patent Claim 5	Automotive Electronics Handbook (Jurgen)	U.S. Patent No. 4,559,599 (Toyota '599)	U.S. Patent No. 4,901,701 (Chasteen)
		 <pre> graph TD     START([START]) --&gt; READ_Nv[READ Nv]     READ_Nv --&gt; DEC{Nv &gt; 1000}     DEC -- NO --&gt; READ_Nv     DEC -- YES --&gt; READ_0[READ 0] </pre>	
<p>said processor subsystem activating said upshift notification circuit if both road speed and throttle position for said vehicle are increasing, manifold pressure for said vehicle is at or below said manifold pressure set point and engine speed for said vehicle is at or above said RPM set point.</p>	<p>E.g., page 13.7 to 13.9, “<i>The basic functions of the transmission control are the shift point control, the lockup control, engine torque control during shifting, related safety functions, and diagnostic functions for vehicle service.</i>”</p> <p>E.g., page 13.9, “The basic shift point control uses shift maps, which are defined in data in the unit memory. These shift maps are selectable over a wide range. <i>The shift point limitations are made</i>, on the one hand, by the highest admissible engine speed for each application and, on the other hand, <i>by the lowest engine speed that is practical for driving comfort and noise emission. The inputs of the shift point determination are the throttle position, the accelerator</i></p>	<p>E.g., col. 2, lines 37 to 42, “<i>The microcomputer 5 further comprises an input/output port (I/O port) 6, a central processing unit (CPU) 7, a read only memory (ROM) 8, and a random access memory (RAM) 9.</i> In the microcomputer 5, there is provided a bus BUS which communicates the I/O port 6 and the CPU 7, ROM 8, and RAM 9.”</p> <p>E.g., col. 2, lines 59 to 63, “<i>The input of the indicator 10 is connected to the output of the I/O port 6 so as to indicate each preferable shift position corresponding to the optimum fuel consumption rate in accordance with various parameters calculated.</i>”</p> <p>E.g., col. 5, line 63 to col. 6, line 2, “<i>Namely, in this step, the speed change operation indicating signal is applied to the indicator or display 10 from the microcomputer 5 through the I/O port 6. As a result, a particular lamp in this case, a shift up indicating lamp in the indicator 10, is illuminated, thus indicating to the drive that the speed change from current shift</i></p>	<p>E.g., col. 9, lines 1 to 8, “The electronic control assembly comprises a number of sensors having sensor outputs which are provided to the CPU 130 through interface circuitry 132. These sensors may include a battery voltage sensor 134, an air temperature sensor 136, an engine temperature sensor 138, an engine speed sensor 140, an ignition timing sensor 142, a barometric pressure sensor 144, and a throttle position sensor 146.”</p> <p>E.g., col. 9, lines 48 to 55, “The CPU 130 receives and processes the signals from the various sensors described above and generates control signals which are used to control fuel pump speed, to maintain the speed of operation of the fuel</p>

Limitation of '781 Patent Claim 5	Automotive Electronics Handbook (Jurgen)	U.S. Patent No. 4,559,599 (Toyota '599)	U.S. Patent No. 4,901,701 (Chasteen)
	<p><i>pedal position, and the vehicle speed (determined by the transmission output speed)."</i></p>	<p><i>position to the one step shifting up position <math>SP_{+1}</math> is preferable."</i></p>	<p>pump at a rate which provides a pressure in the circulation conduit portion immediately downstream therefrom which is approximately equal to the preset maximum pressure of the pressure regulator 114."</p> <p>E.g., col. 11, lines 22 to 33, "As indicated at 303 the CPU determines from the reading taken at 302 whether or not the engine RPM is greater than 0. If engine RPM is greater than 0, the CPU next makes the determination from the throttle position reading of 302 whether or not the throttle position is greater than a predetermined amount, such as 20°, as indicated in block 304. If throttle position is less than 20°, the CPU decision-making process returns to block 302. If the throttle position is greater than the predetermined amount and RPM = 0, the CPU provides a control command to the engine fuel injector(s) to prime the engine."</p> <p>E.g., August 6, 1998 Office Action, "Chasteen discloses the sensors as discussed for sensing the signals and a processor and compare manifold pressure for activating the fuel injection. Chasteen discloses the speed (RPM) and throttle position are determined to be greater than 0 (increasing) and the CPU provides a control command to the engine fuel</p>

Limitation of '781 Patent Claim 5	Automotive Electronics Handbook (Jurgen)	U.S. Patent No. 4,559,599 (Toyota '599)	U.S. Patent No. 4,901,701 (Chasteen)
			injector to prime the engine (See column 11, lines 22-33) therefore on [sic] would consider increasing and decreasing the speed and throttle for adjusting the fuel injector for supplying fuel to the engine.”

Limitation of '781 Patent Claim 8	Automotive Electronics Handbook (Jurgen)	U.S. Patent No. 4,559,599 (Toyota '599)	U.S. Patent No. 4,901,701 (Chasteen)
<p>8. Apparatus for optimizing operation of a vehicle according to claim 7 wherein said processor subsystem further comprises:</p>	<p>See claim 7 claim chart, at page A-16.</p>	<p>See claim 7 claim chart, at page A-16.</p>	<p>E.g., col. 1, lines 9 to 13, "The present invention relates generally to two-stroke operating cycle engines and, more particularly, to a two stroke engine fuel injection system and control system therefor which are adapted for extreme weather conditions."</p> <p>E.g., col. 2, lines 2 to 17, "Small, two-cycle engines are especially subject to malfunction under variable operating conditions such as changes in sea level, with associated barometric changes and changes in ambient air temperature. Many machines such as snowmobiles, snowblowers, dirt bikes, etc., are operated in such widely variable operating conditions. In view of the costs associated with engine modification for sensors' need for electronic control of fuel injectors and in view of the fact that the engine parameters which are critical to control of fuel injectors for two-cycle engines were not, prior to the present invention, understood in the art, a successful electronically-controlled fuel injection system for small, two-cycle engines which are subject to extremes in operating conditions has not been developed in the prior art."</p>
<p>means for determining when road speed for said vehicle is increasing;</p>	<p>E.g., page 7.6, "There are several applications for rotational speed sensing. First it is necessary to monitor engine speed. This information is used for transmission control, engine control, cruise control, and possibly for a tachometer. Electronics and electronic</p>		

Limitation of '781 Patent Claim 8	Automotive Electronics Handbook (Jurgen)	U.S. Patent No. 4,559,599 (Toyota '599)	U.S. Patent No. 4,901,701 (Chasteen)
	<p>sensing in the automobile were brought about by the need for higher efficiency engines, better fuel economy, increased power and performance, and lower emissions. Second, <i>wheel speed sensing is required</i> for use in transmissions, cruise control, speedometers, antilock brake systems (ABS), traction control (ASR), variable ratio power steering assist, four-wheel steering, and possibly in inertial navigation and air bag deployment applications.”</p> <p>E.g., page 7.8, “In electronic transmission applications, <i>information from the road and engine speed sensors</i>, as well as torque data and throttle position are required for the MCU to select the optimum gear ratio.”</p>		
<p>means for determining when throttle position for said vehicle is increasing;</p>	<p>E.g., page 12.18, “To control the idle speed, the ECU uses inputs from the <i>throttle position sensor</i>, air conditioning, automatic transmission, power steering, charging system, engine RPM, and vehicle speed.”</p> <p>E.g., page 12.21, “The electronic injection unit also houses the <i>throttle position sensor</i> and, in some cases, an inlet air temperature sensor which provides operating condition information to the ECU.”</p>	<p>E.g., col. 2, lines 23 to 36, “Referring to FIG. 1, the shift indication apparatus with a manual transmission according to the present invention comprises an engine speed sensor 1 for detecting the engine speed and for producing pulse signals of a frequency proportional to the engine speed, a shift position sensor 2 for detecting the shift positions of the transmission, <i>a throttle sensor 3 for detecting the opening degree of the throttle valve by means of, for instance, a potentiometer</i>, an A/D converter 4 for converting analog signals from the throttle valve sensor 3 into digital signals, a microcomputer 5 for performing various calculations in accordance with the different signals from the sensors, and an</p>	<p>E.g., col. 9, lines 3 to 8, “These sensors may include a battery voltage sensor 134, an air temperature sensor 136, an engine temperature sensor 138, an engine speed sensor 140, an ignition timing sensor 142, a barometric pressure sensor 144, and <i>a throttle position sensor 146.</i>”</p> <p>E.g., FIG. 1</p>

Limitation of '781 Patent Claim 8	Automotive Electronics Handbook (Jurgen)	U.S. Patent No. 4,559,599 (Toyota '599)	U.S. Patent No. 4,901,701 (Chasteen)
		<p>indicator 10 for indicating the result of the calculations.”</p> <p>E.g., col. 2, lines 52 to 59, “Similarly, the output of <i>the throttle sensor 3</i> is connected through the A/D converter 4 to the input of the I/O port 6 so as to transmit the output signals thereof to the microcomputer 5 through the A/D converter 4 and to store the data corresponding to the throttle value opening into the RAM 9 after converting from the analog signals into the digital signals.”</p> <p>E.g., FIG. 1:</p>	
means for comparing manifold pressure to	E.g., page 12.1, “The electronic engine	E.g., col. 2, lines 37 to 42, “The	

Limitation of '781 Patent Claim 8	Automotive Electronics Handbook (Jurgen)	U.S. Patent No. 4,559,599 (Toyota '599)	U.S. Patent No. 4,901,701 (Chasteen)
<p>said manifold pressure set point; and</p>	<p>control system consists of <i>sensing devices which continuously measure the operating conditions of the engine, an electronic control unit (ECU) which evaluates the sensor inputs</i> using data tables and calculations and determines the output to the actuating devices, and actuating devices which are commanded by the ECU to perform an action in response to the sensor inputs.”</p> <p>E.g., page 22.6, “During the entire operating time of the vehicle, <i>the ECUs are constantly supervising the sensors they are connected to.</i>”</p> <p>E.g., page 13.4, “On the functional side, the hardware configuration can be divided into power supply, input signal transfer circuits, output stages, and <i>microcontroller</i>, including peripheral components and monitoring and safety circuits (Fig. 13.1).”</p>	<p>microcomputer 5 further comprises an input/output port (I/O port) 6, a central processing unit (CPU) 7, <i>a read only memory (ROM) 8, and a random access memory (RAM) 9.</i> In the microcomputer 5, there is provided a bus BUS which communicates the I/O port 6 and the CPU 7, <i>ROM 8, and RAM 9.</i>”</p> <p>E.g., col. 3, lines 7 to 20, “<i>The torque data map indicative of torque curves T as shown in FIG. 2 has been stored in the ROM 8 in advance. The fuel consumption rate data map indicative of equal fuel consumption rate curves B as shown in FIG. 3 has been also stored in the ROM 8 in advance. In FIG. 2, each equal torque curve T was prepared by plotting and connecting equal torque points on the graph with respect to the engine speed vs. throttle valve opening. In FIG. 3, each fuel consumption rate curve B was prepared by plotting and connecting equal fuel consumption rate points on a graph obtained in advance by experiment data with respect to the engine speed and the torques thus calculated.</i>”</p>	
<p>said processor subsystem activating said fuel overinjection notification circuit if both road speed and throttle position for said vehicle are increasing and manifold pressure for said vehicle is above said manifold pressure set point.</p>	<p>E.g., page 12.4, “During coasting and braking, fuel consumption can be further reduced by shutting off the fuel until the engine speed decreases to slightly higher than the set idle speed. <i>The ECU determines when fuel shutoff can occur by evaluating the throttle position, engine RPM, and vehicle speed.</i>”</p>		<p>E.g., col. 9, lines 1 to 8, “The electronic control assembly comprises a number of sensors having sensor outputs which are provided to the CPU 130 through interface circuitry 132. These sensors may include a battery voltage sensor 134, an air temperature sensor 136, an engine temperature sensor 138, an engine speed</p>



Limitation of '781 Patent Claim 8	Automotive Electronics Handbook (Jurgen)	U.S. Patent No. 4,559,599 (Toyota '599)	U.S. Patent No. 4,901,701 (Chasteen)
	<p>E.g., page 12.14, "Using the inputs of engine RPM and vehicle speed to the electronic control unit, thresholds can be established for limiting these variables with fuel cutoff. <i>When the maximum speed is achieved, the fuel injectors are shut off.</i> When the speed decreases below the threshold, fuel injection resumes."</p>		<p>sensor 140, an ignition timing sensor 142, a barometric pressure sensor 144, and a throttle position sensor 146."</p> <p>E.g., col. 9, lines 48 to 55, "The CPU 130 receives and processes the signals from the various sensors described above and generates control signals which are used to control fuel pump speed, to maintain the speed of operation of the fuel pump at a rate which provides a pressure in the circulation conduit portion immediately downstream therefrom which is approximately equal to the preset maximum pressure of the pressure regulator 114."</p> <p>E.g., col. 11, lines 22 to 33, "As indicated at 303 the CPU determines from the reading taken at 302 whether or not the engine RPM is greater than 0. If engine RPM is greater than 0, the CPU next makes the determination from the throttle position reading of 302 whether or not the throttle position is greater than a predetermined amount, such as 20°, as indicated in block 304. If throttle position is less than 20°, the CPU decision-making process returns to block 302. If the throttle position is greater than the predetermined amount and RPM = 0, the CPU provides a control command to the engine fuel injector(s) to prime the engine."</p> <p>E.g., August 6, 1998 Office Action, "Chasteen discloses the sensors as discussed for sensing the signals and a</p>

Limitation of '781 Patent Claim 8	Automotive Electronics Handbook (Jurgen)	U.S. Patent No. 4,559,599 (Toyota '599)	U.S. Patent No. 4,901,701 (Chasteen)
			<p>processor and compare manifold pressure for activating the fuel injection. Chasteen discloses the speed (RPM) and throttle position are determined to be greater than 0 (increasing) and the CPU provides a control command to the engine fuel injector to prime the engine (See column 11, lines 22-33) therefore on [sic] would consider increasing and decreasing the speed and throttle for adjusting the fuel injector for supplying fuel to the engine.”</p>

Limitation of '781 Patent Claim 10	Automotive Electronics Handbook (Jurgen)	U.S. Patent No. 4,559,599 (Toyota '599)	U.S. Patent No. 4,901,701 (Chasteen)
<p>10. Apparatus for optimizing operation of a vehicle according to claim 7 wherein said processor subsystem further comprises:</p>	<p>See claim 7 claim chart, at page A-16.</p>	<p>See claim 7 claim chart, at page A-16.</p>	<p>E.g., col. 1, lines 9 to 13, "The present invention relates generally to two-stroke operating cycle engines and, more particularly, to a two stroke engine fuel injection system and control system therefor which are adapted for extreme weather conditions."</p> <p>E.g., col. 2, lines 2 to 17, "Small, two-cycle engines are especially subject to malfunction under variable operating conditions such as changes in sea level, with associated barometric changes and changes in ambient air temperature. Many machines such as snowmobiles, snowblowers, dirt bikes, etc., are operated in such widely variable operating conditions. In view of the costs associated with engine modification for sensors' need for electronic control of fuel injectors and in view of the fact that the engine parameters which are critical to control of fuel injectors for two-cycle engines were not, prior to the present invention, understood in the art, a successful electronically-controlled fuel injection system for small, two-cycle engines which are subject to extremes in operating conditions has not been developed in the prior art."</p>
<p>means for determining when road speed for said vehicle is decreasing;</p>	<p>E.g., page 7.6, "There are several applications for rotational speed sensing. First it is necessary to monitor engine speed. This information is used for transmission control, engine control, cruise control, and possibly for a</p>		

Limitation of '781 Patent Claim 10	Automotive Electronics Handbook (Jurgen)	U.S. Patent No. 4,559,599 (Toyota '599)	U.S. Patent No. 4,901,701 (Chasteen)
	<p>tachometer. Electronics and electronic sensing in the automobile were brought about by the need for higher efficiency engines, better fuel economy, increased power and performance, and lower emissions. Second, <i>wheel speed sensing is required</i> for use in transmissions, cruise control, speedometers, antilock brake systems (ABS), traction control (ASR), variable ratio power steering assist, four-wheel steering, and possibly in inertial navigation and air bag deployment applications.”</p> <p>E.g., page 7.8, “In electronic transmission applications, <i>information from the road and engine speed sensors</i>, as well as torque data and throttle position are required for the MCU to select the optimum gear ratio.”</p>		
<p>means for determining when throttle position for said vehicle is increasing;</p>	<p>E.g., page 12.18, “To control the idle speed, the ECU uses inputs from the <i>throttle position sensor</i>, air conditioning, automatic transmission, power steering, charging system, engine RPM, and vehicle speed.”</p> <p>E.g., page 12.21, “The electronic injection unit also houses the <i>throttle position sensor</i> and, in some cases, an inlet air temperature sensor which provides operating condition information to the ECU.”</p>	<p>E.g., col. 2, lines 23 to 36, “Referring to FIG. 1, the shift indication apparatus with a manual transmission according to the present invention comprises an engine speed sensor 1 for detecting the engine speed and for producing pulse signals of a frequency proportional to the engine speed, a shift position sensor 2 for detecting the shift positions of the transmission, <i>a throttle sensor 3 for detecting the opening degree of the throttle valve by means of, for instance, a potentiometer</i>, an A/D converter 4 for converting analog signals from the throttle valve sensor 3 into digital signals, a microcomputer 5 for performing various calculations in accordance with the different signals from the sensors, and an</p>	<p>E.g., col. 9, lines 3 to 8, “These sensors may include a battery voltage sensor 134, an air temperature sensor 136, an engine temperature sensor 138, an engine speed sensor 140, an ignition timing sensor 142, a barometric pressure sensor 144, and <i>a throttle position sensor 146.</i>”</p> <p>E.g., FIG. 1</p>

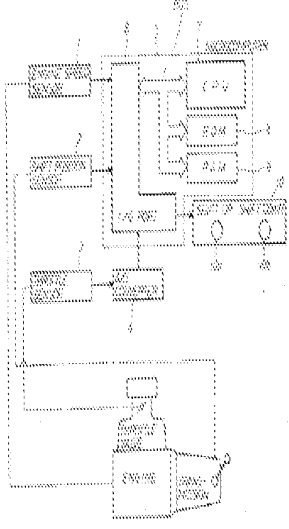
Limitation of '781 Patent Claim 10	Automotive Electronics Handbook (Jurgen)	U.S. Patent No. 4,559,599 (Toyota '599)	U.S. Patent No. 4,901,701 (Chasteen)
		<p>indicator 10 for indicating the result of the calculations.”</p> <p>E.g., col. 2, lines 52 to 59, “Similarly, the output of <i>the throttle sensor 3</i> is connected through the A/D converter 4 to the input of the I/O port 6 so as to transmit the output signals thereof to the microcomputer 5 through the A/D converter 4 and to store the data corresponding to the throttle value opening into the RAM 9 after converting from the analog signals into the digital signals.”</p> <p>E.g., FIG. 1:</p> 	
<p>means for determining when manifold pressure for said vehicle is increasing;</p>	<p>E.g., page 2.5, “Automotive specification and testing guidelines have been developed and published by the Society of Automotive Engineers (SAE) specifically for <i>manifold absolute pressure (MAP) sensors</i>.”</p>		

Limitation of '781 Patent Claim 10	Automotive Electronics Handbook (Jurgen)	U.S. Patent No. 4,559,599 (Toyota '599)	U.S. Patent No. 4,901,701 (Chasteen)
	<p>E.g., page 2.7, "Manifold absolute pressure (MAP) is used as an input to fuel and ignition control in internal combustion engine control systems. <i>The speed-density system that uses the MAP sensor</i> has been preferred over mass air flow (MAF) control because it's less expensive, but stricter emission standards are causing more manufacturers to use mass air flow for future models."</p>		
<p>means for determining when engine speed for said vehicle is decreasing;</p>	<p>E.g., page 7.6, "There are several applications for rotational speed sensing. <i>First it is necessary to monitor engine speed.</i> This information is used for transmission control, engine control, cruise control, and possibly for a tachometer. Electronics and electronic sensing in the automobile were brought about by the need for higher efficiency engines, better fuel economy, increased power and performance, and lower emissions. Second, wheel speed sensing is required for use in transmissions, cruise control, speedometers, antilock brake systems (ABS), traction control (ASR), variable ratio power steering assist, four-wheel steering, and possibly in inertial navigation and air bag deployment applications."</p> <p>E.g., page 7.8, "In electronic transmission applications, <i>information from the road and engine speed sensors</i>, as well as torque data and throttle position are required for the MCU to select the optimum gear ratio."</p>	<p>E.g., col. 2, lines 23 to 36, "Referring to FIG. 1, the shift indication apparatus with a manual transmission according to the present invention comprises <i>an engine speed sensor 1 for detecting the engine speed and for producing pulse signals of a frequency proportional to the engine speed</i>, a shift position sensor 2 for detecting the shift positions of the transmission, <i>a throttle sensor 3 for detecting the opening degree of the throttle valve by means of, for instance, a potentiometer</i>, an A/D converter 4 for converting analog signals from the throttle valve sensor 3 into digital signals, a microcomputer 5 for performing various calculations in accordance with the different signals from the sensors, and an indicator 10 for indicating the result of the calculations."</p> <p>E.g., col. 2, lines 43 to 48, "<i>The engine speed sensor 1</i> is mounted in a distributor (not shown) and the output of the sensor is connected to the input of the I/O port 6 so as to transmit the output pulses to the</p>	<p>E.g., col. 9, lines 3 to 8, "These sensors may include a battery voltage sensor 134, an air temperature sensor 136, an engine temperature sensor 138, <i>an engine speed sensor 140</i>, an ignition timing sensor 142, a barometric pressure sensor 144, and a throttle position sensor 146."</p> <p>E.g., FIG. 1</p>

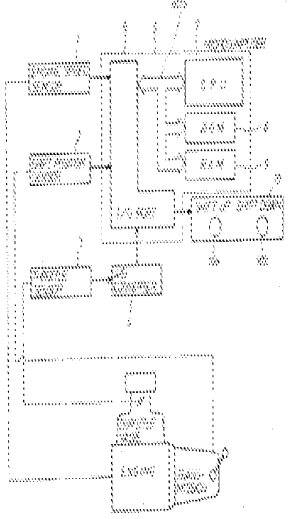
Limitation of '781 Patent Claim 10	Automotive Electronics Handbook (Jurgen)	U.S. Patent No. 4,559,599 (Toyota '599)	U.S. Patent No. 4,901,701 (Chasteen)
		<p>microcomputer 5 through the I/O port 6 and to store the data corresponding to the engine speed into the RAM 9.”</p> <p>E.g., FIG. 1:</p> 	
<p>said processor subsystem activating said downshift notification circuit if both road speed and engine speed are decreasing and both throttle position and manifold pressure for said vehicle are increasing.</p>	<p>E.g., page 13.7 to 13.9, “<i>The basic functions of the transmission control are the shift point control, the lockup control, engine torque control during shifting, related safety functions, and diagnostic functions for vehicle service.</i>”</p> <p>E.g., page 13.9, “The basic shift point control uses shift maps, which are defined in data in the unit memory. These shift maps are selectable over a wide range. <i>The shift point limitations are made, on the one hand, by the highest admissible engine speed for each application and, on the other hand, by the lowest engine speed that is practical for driving comfort and noise emission. The inputs</i></p>	<p>E.g., col. 2, lines 37 to 42, “<i>The microcomputer 5 further comprises an input/output port (I/O port) 6, a central processing unit (CPU) 7, a read only memory (ROM) 8, and a random access memory (RAM) 9.</i> In the microcomputer 5, there is provided a bus BUS which communicates the I/O port 6 and the CPU 7, ROM 8, and RAM 9.”</p> <p>E.g., col. 2, lines 59 to 63, “<i>The input of the indicator 10 is connected to the output of the I/O port 6 so as to indicate each preferable shift position corresponding to the optimum fuel consumption rate in accordance with various parameters calculated.</i>”</p>	<p>E.g., col. 9, lines 1 to 8, “The electronic control assembly comprises a number of sensors having sensor outputs which are provided to the CPU 130 through interface circuitry 132. These sensors may include a battery voltage sensor 134, an air temperature sensor 136, an engine temperature sensor 138, an engine speed sensor 140, an ignition timing sensor 142, a barometric pressure sensor 144, and a throttle position sensor 146.”</p> <p>E.g., col. 9, lines 48 to 55, “The CPU 130 receives and processes the signals from the various sensors described above and generates control signals which are used to control fuel pump speed, to maintain</p>

Limitation of '781 Patent Claim 10	Automotive Electronics Handbook (Jurgen)	U.S. Patent No. 4,559,599 (Toyota '599)	U.S. Patent No. 4,901,701 (Chasteen)
	<p><i>of the shift point determination are the throttle position, the accelerator pedal position, and the vehicle speed (determined by the transmission output speed)."</i></p>	<p>E.g., col. 5, line 63 to col. 6, line 2, <i>"Namely, in this step, the speed change operation indicating signal is applied to the indicator or display 10 from the microcomputer 5 through the I/O port 6. As a result, a particular lamp in this case, a shift up indicating lamp in the indicator 10, is illuminated, thus indicating to the drive that the speed change from current shift position to the one step shifting up position SP<sub>+1</sub> is preferable."</i></p> <p>E.g., col. 2, line 64 to col. 3, line 3, <i>"The indicator 10 includes a shift-up indicating lamp 10a and a shift-down indicating lamp 10b.</i></p> <p><i>The indicator 10 may be assembled by light emitting [sic] diodes (LED) so as to perform shift-up and shift-down indications by up and down directed arrow marks. Alternatively, the indicator 10 may also be replaced with other voice combining circuit so as to announce the shift operations by voice instead of the indications."</i></p> <p>E.g., col. 7, lines 10 to 17, <i>"In this step 42, shift-down display is performed. Namely in this case, the shift down display instruction signal from the microcomputer 5 is applied to the indicator 10 through the I/O port 6 and the shift-down indication lamp in the indicator 10 is illuminated, thus indicating to the driver that speed change</i></p>	<p>the speed of operation of the fuel pump at a rate which provides a pressure in the circulation conduit portion immediately downstream therefrom which is approximately equal to the preset maximum pressure of the pressure regulator 114."</p> <p>E.g., col. 11, lines 22 to 33, "As indicated at 303 the CPU determines from the reading taken at 302 whether or not the engine RPM is greater than 0. If engine RPM is greater than 0, the CPU next makes the determination from the throttle position reading of 302 whether or not the throttle position is greater than a predetermined amount, such as 20°, as indicated in block 304. If throttle position is less than 20°, the CPU decision-making process returns to block 302. If the throttle position is greater than the predetermined amount and RPM = 0, the CPU provides a control command to the engine fuel injector(s) to prime the engine."</p> <p>E.g., Statement of Examiner, "Chasteen discloses the sensors as discussed for sensing the signals and a processor and compare manifold pressure for activating the fuel injection. Chasteen discloses the speed (RPM) and throttle position are determined to be greater than 0 (increasing) and the CPU provides a control command to the engine fuel injector to prime the engine (See column 11, lines 22-33) therefore on [sic] would consider increasing and decreasing the</p>



Limitation of '781 Patent Claim 10	Automotive Electronics Handbook (Jurgen)	U.S. Patent No. 4,559,599 (Toyota '599)	U.S. Patent No. 4,901,701 (Chasteen)
		<p>operation from the current shift position to the one step shifting down position SP<sub>1</sub> is preferable.”</p> <p>E.g. col. 7, lines 29 to 38, “However, <i>only when either one of the assumed fuel consumption rates above is better than the current fuel consumption rate B<sub>0</sub>, the corresponding shift-up lamp or shift-down lamp in the indicator 10 is illuminated</i>, thus indicating the necessity of the speed change operation.”</p>	<p>speed and throttle for adjusting the fuel injector for supplying fuel to the engine.”</p> <p>E.g., August 6, 1998 Office Action, “Chasteen discloses the sensors as discussed for sensing the signals and a processor and compare manifold pressure for activating the fuel injection. Chasteen discloses the speed (RPM) and throttle position are determined to be greater than 0 (increasing) and the CPU provides a control command to the engine fuel injector to prime the engine (See column 11, lines 22-33) therefore on [sic] would consider increasing and decreasing the speed and throttle for adjusting the fuel injector for supplying fuel to the engine.”</p>

Limitation of '781 Patent Claim 12	Automotive Electronics Handbook (Jurgen)	U.S. Patent No. 4,559,599 (Toyota '599)	U.S. Patent No. 4,901,701 (Chasteen)
<p>12. Apparatus for optimizing operation of a vehicle according to claim 7 wherein said processor subsystem further comprises:</p>	<p>See claim 7 claim chart, at page A-16.</p>	<p>See claim 7 claim chart, at page A-16.</p>	<p>E.g., col. 1, lines 9 to 13, "The present invention relates generally to two-stroke operating cycle engines and, more particularly, to a two stroke engine fuel injection system and control system therefor which are adapted for extreme weather conditions."</p> <p>E.g., col. 2, lines 2 to 17, "Small, two-cycle engines are especially subject to malfunction under variable operating conditions such as changes in sea level, with associated barometric changes and changes in ambient air temperature. Many machines such as snowmobiles, snowblowers, dirt bikes, etc., are operated in such widely variable operating conditions. In view of the costs associated with engine modification for sensors' need for electronic control of fuel injectors and in view of the fact that the engine parameters which are critical to control of fuel injectors for two-cycle engines were not, prior to the present invention, understood in the art, a successful electronically-controlled fuel injection system for small, two-cycle engines which are subject to extremes in operating conditions has not been developed in the prior art."</p>
<p>means for determining when road speed for said vehicle is decreasing;</p>	<p>E.g., page 7.6, "There are several applications for rotational speed sensing. First it is necessary to monitor engine speed. This information is used for transmission control, engine control, cruise control, and possibly for a</p>		

Limitation of '781 Patent Claim 12	Automotive Electronics Handbook (Jurgen)	U.S. Patent No. 4,559,599 (Toyota '599)	U.S. Patent No. 4,901,701 (Chasteen)
	<p>tachometer. Electronics and electronic sensing in the automobile were brought about by the need for higher efficiency engines, better fuel economy, increased power and performance, and lower emissions. Second, <i>wheel speed sensing is required</i> for use in transmissions, cruise control, speedometers, antilock brake systems (ABS), traction control (ASR), variable ratio power steering assist, four-wheel steering, and possibly in inertial navigation and air bag deployment applications.”</p> <p>E.g., page 7.8, “In electronic transmission applications, <i>information from the road and engine speed sensors</i>, as well as torque data and throttle position are required for the MCU to select the optimum gear ratio.”</p>		
<p>means for determining when throttle position for said vehicle is increasing;</p>	<p>E.g., page 12.18, “To control the idle speed, the ECU uses inputs from the <i>throttle position sensor</i>, air conditioning, automatic transmission, power steering, charging system, engine RPM, and vehicle speed.”</p> <p>E.g., page 12.21, “The electronic injection unit also houses the <i>throttle position sensor</i> and, in some cases, an inlet air temperature sensor which provides operating condition information to the ECU.”</p>	<p>E.g., col. 2, lines 23 to 36, “Referring to FIG. 1, the shift indication apparatus with a manual transmission according to the present invention comprises an engine speed sensor 1 for detecting the engine speed and for producing pulse signals of a frequency proportional to the engine speed, a shift position sensor 2 for detecting the shift positions of the transmission, <i>a throttle sensor 3 for detecting the opening degree of the throttle valve by means of, for instance, a potentiometer</i>, an A/D converter 4 for converting analog signals from the throttle valve sensor 3 into digital signals, a microcomputer 5 for performing various calculations in accordance with the different signals from the sensors, and an</p>	<p>E.g., col. 9, lines 3 to 8, “These sensors may include a battery voltage sensor 134, an air temperature sensor 136, an engine temperature sensor 138, an engine speed sensor 140, an ignition timing sensor 142, a barometric pressure sensor 144, and <i>a throttle position sensor 146.</i>”</p> <p>E.g., FIG. 1</p>

Limitation of '781 Patent Claim 12	Automotive Electronics Handbook (Jurgen)	U.S. Patent No. 4,559,599 (Toyota '599)	U.S. Patent No. 4,901,701 (Chasteen)
		<p>indicator 10 for indicating the result of the calculations.”</p> <p>E.g., col. 2, lines 52 to 59, “Similarly, the output of <i>the throttle sensor 3</i> is connected through the A/D converter 4 to the input of the I/O port 6 so as to transmit the output signals thereof to the microcomputer 5 through the A/D converter 4 and to store the data corresponding to the throttle value opening into the RAM 9 after converting from the analog signals into the digital signals.”</p> <p>E.g., FIG. 1:</p>	
<p>means for determining when manifold pressure for said vehicle is increasing;</p>	<p>E.g., page 12.1, “The electronic engine control system consists of <i>sensing devices which continuously measure the operating conditions of the engine, an electronic control unit (ECU) which evaluates the sensor inputs</i> using data tables and calculations and determines the</p>		

Limitation of '781 Patent Claim 12	Automotive Electronics Handbook (Jurgen)	U.S. Patent No. 4,559,599 (Toyota '599)	U.S. Patent No. 4,901,701 (Chasteen)
	<p>output to the actuating devices, and actuating devices which are commanded by the ECU to perform an action in response to the sensor inputs.”</p> <p>E.g., page 22.6, “During the entire operating time of the vehicle, <i>the ECUs are constantly supervising the sensors they are connected to.</i>”</p> <p>E.g., page 13.4, “On the functional side, the hardware configuration can be divided into power supply, input signal transfer circuits, output stages, and <i>microcontroller</i>, including peripheral components and monitoring and safety circuits (Fig. 13.1).”</p>		
<p>means for determining when engine speed for said vehicle is decreasing;</p>	<p>E.g., page 12.4, “During coasting and braking, fuel consumption can be further reduced by shutting off the fuel until the engine speed decreases to slightly higher than the set idle speed. <i>The ECU determines when fuel shutoff can occur by evaluating the throttle position, engine RPM, and vehicle speed.</i>”</p> <p>E.g., page 12.14, “Using the inputs of engine RPM and vehicle speed to the electronic control unit, thresholds can be established for limiting these variables with fuel cutoff. <i>When the maximum speed is achieved, the fuel injectors are shut off.</i> When the speed decreases below the threshold, fuel injection resumes.”</p> <p>E.g., page 13.7 to 13.9, “<i>The basic functions of the transmission control are</i></p>		<p>E.g., col. 9, lines 3 to 8, “These sensors may include a battery voltage sensor 134, an air temperature sensor 136, an engine temperature sensor 138, <i>an engine speed sensor 140</i>, an ignition timing sensor 142, a barometric pressure sensor 144, and a throttle position sensor 146.”</p> <p>E.g., FIG. 1</p>

Limitation of '781 Patent Claim 12	Automotive Electronics Handbook (Jurgen)	U.S. Patent No. 4,559,599 (Toyota '599)	U.S. Patent No. 4,901,701 (Chasteen)
	<p><i>the shift point control</i>, the lockup control, engine torque control during shifting, related safety functions, and diagnostic functions for vehicle service.”</p> <p>E.g., page 13.9, “The basic shift point control uses shift maps, which are defined in data in the unit memory. These shift maps are selectable over a wide range. <b>The shift point limitations are made</b>, on the one hand, by the highest admissible engine speed for each application and, on the other hand, <i>by the lowest engine speed that is practical for driving comfort and noise emission. The inputs of the shift point determination are the throttle position, the accelerator pedal position, and the vehicle speed</i> (determined by the transmission output speed).”</p>		
<p>said processor subsystem activating said fuel overinjection notification circuit if both throttle position and manifold pressure for said vehicle are increasing and road speed and engine speed for said vehicle are decreasing.</p>	<p>E.g., page 13.7 to 13.9, “<b>The basic functions of the transmission control are the shift point control</b>, the lockup control, engine torque control during shifting, related safety functions, and diagnostic functions for vehicle service.”</p> <p>E.g., page 13.9, “The basic shift point control uses shift maps, which are defined in data in the unit memory. These shift maps are selectable over a wide range. <b>The shift point limitations are made</b>, on the one hand, by the highest admissible engine speed for each application and, on the other hand, <i>by the lowest engine speed that is practical for driving comfort and noise emission. The inputs</i></p>	<p>E.g., col. 2, lines 37 to 42, “<b>The microcomputer 5 further comprises an input/output port (I/O port) 6, a central processing unit (CPU) 7, a read only memory (ROM) 8, and a random access memory (RAM) 9.</b> In the microcomputer 5, there is provided a bus BUS which communicates the I/O port 6 and the CPU 7, ROM 8, and RAM 9.”</p> <p>E.g., col. 2, lines 59 to 63, “<b>The input of the indicator 10 is connected to the output of the I/O port 6 so as to indicate each preferable shift position corresponding to the optimum fuel consumption rate in accordance with</b></p>	<p>E.g., col. 9, lines 1 to 8, “The electronic control assembly comprises a number of sensors having sensor outputs which are provided to the CPU 130 through interface circuitry 132. These sensors may include a battery voltage sensor 134, an air temperature sensor 136, an engine temperature sensor 138, an engine speed sensor 140, an ignition timing sensor 142, a barometric pressure sensor 144, and a throttle position sensor 146.”</p> <p>E.g., col. 9, lines 48 to 55, “The CPU 130 receives and processes the signals from the various sensors described above and generates control signals which are used</p>

Limitation of '781 Patent Claim 12	Automotive Electronics Handbook (Jurgen)	U.S. Patent No. 4,559,599 (Toyota '599)	U.S. Patent No. 4,901,701 (Chasteen)
	<p><i>of the shift point determination are the throttle position, the accelerator pedal position, and the vehicle speed (determined by the transmission output speed)."</i></p>	<p><i>various parameters calculated."</i></p> <p>E.g., col. 5, line 63 to col. 6, line 2, <i>"Namely, in this step, the speed change operation indicating signal is applied to the indicator or display 10 from the microcomputer 5 through the I/O port 6. As a result, a particular lamp in this case, a shift up indicating lamp in the indicator 10, is illuminated, thus indicating to the drive that the speed change from current shift position to the one step shifting up position SP<sub>+1</sub> is preferable."</i></p> <p>E.g., col. 2, line 64 to col. 3, line 3, <i>"The indicator 10 includes a shift-up indicating lamp 10a and a shift-down indicating lamp 10b.</i></p> <p><i>The indicator 10 may be assembled by light emitting [sic] diodes (LED) so as to perform shift-up and shift-down indications by up and down directed arrow marks. Alternatively, the indicator 10 may also be replaced with other voice combining circuit so as to announce the shift operations by voice instead of the indications."</i></p> <p>E.g., col. 7, lines 10 to 17, <i>"In this step 42, shift-down display is performed. Namely in this case, the shift down display instruction signal from the microcomputer 5 is applied to the indicator 10 through the I/O port 6 and the shift-down indication lamp in the indicator 10 is illuminated, thus</i></p>	<p>to control fuel pump speed, to maintain the speed of operation of the fuel pump at a rate which provides a pressure in the circulation conduit portion immediately downstream therefrom which is approximately equal to the preset maximum pressure of the pressure regulator 114."</p> <p>E.g., col. 11, lines 22 to 33, "As indicated at 303 the CPU determines from the reading taken at 302 whether or not the engine RPM is greater than 0. If engine RPM is greater than 0, the CPU next makes the determination from the throttle position reading of 302 whether or not the throttle position is greater than a predetermined amount, such as 20°, as indicated in block 304. If throttle position is less than 20°, the CPU decision-making process returns to block 302. If the throttle position is greater than the predetermined amount and RPM = 0, the CPU provides a control command to the engine fuel injector(s) to prime the engine."</p> <p>E.g., Statement of Examiner, "Chasteen discloses the sensors as discussed for sensing the signals and a processor and compare manifold pressure for activating the fuel injection. Chasteen discloses the speed (RPM) and throttle position are determined to be greater than 0 (increasing) and the CPU provides a control command to the engine fuel injector to prime the engine (See column 11, lines 22-33) therefore on [sic] would</p>

Limitation of '781 Patent Claim 12	Automotive Electronics Handbook (Jurgen)	U.S. Patent No. 4,559,599 (Toyota '599)	U.S. Patent No. 4,901,701 (Chasteen)
		<p>indicating to the driver that speed change operation from the current shift position to the one step shifting down position SP<sub>1</sub> is preferable.”</p> <p>E.g. col. 7, lines 29 to 38, “However, <i>only when either one of the assumed fuel consumption rates above is better than the current fuel consumption rate B<sub>0</sub>, the corresponding shift-up lamp or shift-down lamp in the indicator 10 is illuminated</i>, thus indicating the necessity of the speed change operation.”</p>	<p>consider increasing and decreasing the speed and throttle for adjusting the fuel injector for supplying fuel to the engine.”</p> <p>E.g., August 6, 1998 Office Action, “Chasteen discloses the sensors as discussed for sensing the signals and a processor and compare manifold pressure for activating the fuel injection. Chasteen discloses the speed (RPM) and throttle position are determined to be greater than 0 (increasing) and the CPU provides a control command to the engine fuel injector to prime the engine (See column 11, lines 22-33) therefore on [sic] would consider increasing and decreasing the speed and throttle for adjusting the fuel injector for supplying fuel to the engine.”</p>



Limitation of '781 Patent Claim 15	Automotive Electronics Handbook (Jurgen)	U.S. Patent No. 4,559,599 (Toyota '599)	U.S. Patent No. 4,901,701 (Chasteen)
<p>15. Apparatus for optimizing operation of a vehicle according to claim 13 wherein said processor subsystem further comprises:</p>	<p>See claim 13 claim chart, at page A-23.</p>	<p>See claim 13 claim chart, at page A-23.</p>	<p>E.g., col. 1, lines 9 to 13, "The present invention relates generally to two-stroke operating cycle engines and, more particularly, to a two stroke engine fuel injection system and control system therefor which are adapted for extreme weather conditions."</p> <p>E.g., col. 2, lines 2 to 17, "Small, two-cycle engines are especially subject to malfunction under variable operating conditions such as changes in sea level, with associated barometric changes and changes in ambient air temperature. Many machines such as snowmobiles, snowblowers, dirt bikes, etc., are operated in such widely variable operating conditions. In view of the costs associated with engine modification for sensors' need for electronic control of fuel injectors and in view of the fact that the engine parameters which are critical to control of fuel injectors for two-cycle engines were not, prior to the present invention, understood in the art, a successful electronically-controlled fuel injection system for small, two-cycle engines which are subject to extremes in operating conditions has not been developed in the prior art."</p>
<p>means for determining when road speed for said vehicle is increasing or decreasing;</p>	<p>E.g., page 7.6, "There are several applications for rotational speed sensing. First it is necessary to monitor engine speed. This information is used for transmission control, engine control, cruise control, and possibly for a</p>		

Limitation of '781 Patent Claim 15	Automotive Electronics Handbook (Jurgen)	U.S. Patent No. 4,559,599 (Toyota '599)	U.S. Patent No. 4,901,701 (Chasteen)
	<p>tachometer. Electronics and electronic sensing in the automobile were brought about by the need for higher efficiency engines, better fuel economy, increased power and performance, and lower emissions. Second, <b>wheel speed sensing is required</b> for use in transmissions, cruise control, speedometers, antilock brake systems (ABS), traction control (ASR), variable ratio power steering assist, four-wheel steering, and possibly in inertial navigation and air bag deployment applications.”</p> <p>E.g., page 7.8, “In electronic transmission applications, <b>information from the road and engine speed sensors</b>, as well as torque data and throttle position are required for the MCU to select the optimum gear ratio.”</p>		
<p>means for determining when throttle position for said vehicle is increasing;</p>	<p>E.g., page 12.18, “To control the idle speed, the ECU uses inputs from the <b>throttle position sensor</b>, air conditioning, automatic transmission, power steering, charging system, engine RPM, and vehicle speed.”</p> <p>E.g., page 12.21, “The electronic injection unit also houses the <b>throttle position sensor</b> and, in some cases, an inlet air temperature sensor which provides operating condition information to the ECU.”</p>	<p>E.g., col. 2, lines 23 to 36, “Referring to FIG. 1, the shift indication apparatus with a manual transmission according to the present invention comprises an engine speed sensor 1 for detecting the engine speed and for producing pulse signals of a frequency proportional to the engine speed, a shift position sensor 2 for detecting the shift positions of the transmission, <b>a throttle sensor 3 for detecting the opening degree of the throttle valve by means of, for instance, a potentiometer</b>, an A/D converter 4 for converting analog signals from the throttle valve sensor 3 into digital signals, a microcomputer 5 for performing various calculations in accordance with the</p>	<p>E.g., col. 9, lines 3 to 8, “These sensors may include a battery voltage sensor 134, an air temperature sensor 136, an engine temperature sensor 138, an engine speed sensor 140, an ignition timing sensor 142, a barometric pressure sensor 144, and <b>a throttle position sensor 146.</b>”</p> <p>E.g., FIG. 1</p>

Limitation of '781 Patent Claim 15	Automotive Electronics Handbook (Jurgen)	U.S. Patent No. 4,559,599 (Toyota '599)	U.S. Patent No. 4,901,701 (Chasteen)
		<p>different signals from the sensors, and an indicator 10 for indicating the result of the calculations.”</p> <p>E.g., col. 2, lines 52 to 59, “Similarly, the output of <i>the throttle sensor 3</i> is connected through the A/D converter 4 to the input of the I/O port 6 so as to transmit the output signals thereof to the microcomputer 5 through the A/D converter 4 and to store the data corresponding to the throttle value opening into the RAM 9 after converting from the analog signals into the digital signals.”</p> <p>E.g., FIG. 1:</p>	
<p>means for comparing manifold pressure to said manifold pressure set point;</p>	<p>E.g., page 12.1, “The electronic engine control system consists of <i>sensing devices which continuously measure the operating conditions of the engine, an</i></p>		<p>E.g., col. 11, lines 22 to 33, “As indicated at 303 the CPU determines from the reading taken at 302 whether or not the engine RPM is greater than 0. If engine</p>

Limitation of '781 Patent Claim 15	Automotive Electronics Handbook (Jurgen)	U.S. Patent No. 4,559,599 (Toyota '599)	U.S. Patent No. 4,901,701 (Chasteen)
	<p><i>electronic control unit (ECU) which evaluates the sensor inputs using data tables and calculations and determines the output to the actuating devices, and actuating devices which are commanded by the ECU to perform an action in response to the sensor inputs.”</i></p> <p>E.g., page 22.6, “During the entire operating time of the vehicle, <i>the ECUs are constantly supervising the sensors they are connected to.</i>”</p> <p>E.g., page 13.4, “On the functional side, the hardware configuration can be divided into power supply, input signal transfer circuits, output stages, and <i>microcontroller</i>, including peripheral components and monitoring and safety circuits (Fig. 13.1).”</p>		<p>RPM is greater than 0, the CPU next makes the determination from the throttle position reading of 302 whether or not the throttle position is greater than a predetermined amount, such as 20°, as indicated in block 304. If throttle position is less than 20°, the CPU decision-making process returns to block 302. If the throttle position is greater than the predetermined amount and RPM = 0, the CPU provides a control command to the engine fuel injector(s) to prime the engine.”</p>
<p>means for comparing engine speed to said RPM set point;</p>	<p>E.g., page 13.7 to 13.9, “<i>The basic functions of the transmission control are the shift point control, the lockup control, engine torque control during shifting, related safety functions, and diagnostic functions for vehicle service.</i>”</p> <p>E.g., page 13.9, “The basic shift point control uses shift maps, which are defined in data in the unit memory. These shift maps are selectable over a wide range. <i>The shift point limitations are made, on the one hand, by the highest admissible engine speed for each application and, on the other hand, by the lowest engine speed that is practical for driving comfort and noise emission. The inputs</i></p>	<p>E.g., col. 2, lines 37 to 42, “The microcomputer 5 further comprises an input/output port (I/O port) 6, a central processing unit (CPU) 7, <i>a read only memory (ROM) 8, and a random access memory (RAM) 9.</i> In the microcomputer 5, there is provided a bus BUS which communicates the I/O port 6 and the CPU 7, <i>ROM 8, and RAM 9.</i>”</p> <p>E.g., col. 3, lines 7 to 20, “<i>The torque data map indicative of torque curves T as shown in FIG. 2 has been stored in the ROM 8 in advance. The fuel consumption rate data map indicative of equal fuel consumption rate curves B as shown in FIG. 3 has been also stored in</i></p>	<p>E.g., col. 11, lines 22 to 33, “<i>As indicated at 303 the CPU determines from the reading taken at 302 whether or not the engine RPM is greater than 0.</i> If engine RPM is greater than 0, the CPU next makes the determination from the throttle position reading of 302 whether or not the throttle position is greater than a predetermined amount, such as 20°, as indicated in block 304. If throttle position is less than 20°, the CPU decision-making process returns to block 302. <i>If the throttle position is greater than the predetermined amount and RPM = 0, the CPU provides a control command to the engine fuel injector(s) to prime the engine.</i>”</p>

Limitation of '781 Patent Claim 15	Automotive Electronics Handbook (Jurgen)	U.S. Patent No. 4,559,599 (Toyota '599)	U.S. Patent No. 4,901,701 (Chasteen)
	<p><i>of the shift point determination are the throttle position, the accelerator pedal position, and the vehicle speed (determined by the transmission output speed)."</i></p>	<p><i>the ROM 8 in advance. In FIG. 2, each equal torque curve T was prepared by plotting and connecting equal torque points on the graph with respect to the engine speed vs. throttle valve opening. In FIG. 3, each fuel consumption rate curve B was prepared by plotting and connecting equal fuel consumption rate points on a graph obtained in advance by experiment data with respect to the engine speed and the torques thus calculated."</i></p> <p><i>E.g., col. 3, lines 44 to 61, "In this case, as shown in FIG. 4, the operation of a main routine is started at a predetermined timing, e.g. periodical timing pulses from a timer (not shown) and the detection of the engine speed <math>N_e</math> from the sensor 1 is carried out and it is stored into the RAM 9 at the step 20. Then, the engine speed <math>N_e</math> is read from the RAM 9 and it is compared with a predetermined number <math>N (=1000 \text{ rpm})</math> to determine whether or not the <math>N_e</math> exceeds the value 1000 at the step 21. If the result of the decision is YES, the next step 22 is executed. That is, in the step 22, the reading in of the opening of the throttle valve is performed through the throttle sensor 3 and the A/D converter 4. In the above case, if the result of the decision in step 21 is NO, the main routine is terminated by determining that the shift operation is not necessary and the engine speed <math>N_e</math> is read again at the predetermined timing and now the operation returns to the step 20."</i></p>	

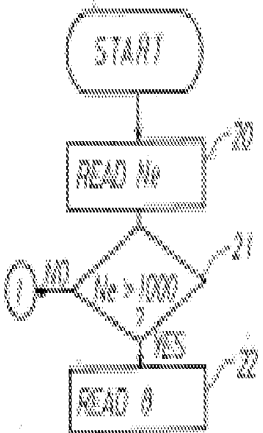
Limitation of '781 Patent Claim 15	Automotive Electronics Handbook (Jurgen)	U.S. Patent No. 4,559,599 (Toyota '599)	U.S. Patent No. 4,901,701 (Chasteen)
		<p>E.g., Figure 4:</p>  <pre> graph TD     Start([START]) --&gt; ReadNo[READ No 20]     ReadNo --&gt; Decision{No &gt; 1000 21}     Decision -- NO --&gt; ReadNo     Decision -- YES --&gt; Read0[READ 0 22] </pre>	
<p>means for determining when manifold pressure is increasing;</p>	<p>E.g., page 12.1, “The electronic engine control system consists of <i>sensing devices which continuously measure the operating conditions of the engine, an electronic control unit (ECU) which evaluates the sensor inputs</i> using data tables and calculations and determines the output to the actuating devices, and actuating devices which are commanded by the ECU to perform an action in response to the sensor inputs.”</p> <p>E.g., page 22.6, “During the entire operating time of the vehicle, <i>the ECUs are constantly supervising the sensors they are connected to.</i>”</p> <p>E.g., page 13.4, “On the functional side, the hardware configuration can be divided into power supply, input signal transfer</p>		

Limitation of '781 Patent Claim 15	Automotive Electronics Handbook (Jurgen)	U.S. Patent No. 4,559,599 (Toyota '599)	U.S. Patent No. 4,901,701 (Chasteen)
	circuits, output stages, and <i>microcontroller</i> , including peripheral components and monitoring and safety circuits (Fig. 13.1)."		
means for determining when engine speed is increasing or decreasing;	<p>E.g., page 12.4, "During coasting and braking, fuel consumption can be further reduced by shutting off the fuel until the engine speed decreases to slightly higher than the set idle speed. <i>The ECU determines when fuel shutoff can occur by evaluating the throttle position, engine RPM, and vehicle speed.</i>"</p> <p>E.g., page 12.14, "Using the inputs of engine RPM and vehicle speed to the electronic control unit, thresholds can be established for limiting these variables with fuel cutoff. <i>When the maximum speed is achieved, the fuel injectors are shut off.</i> When the speed decreases below the threshold, fuel injection resumes."</p> <p>E.g., page 13.7 to 13.9, "<i>The basic functions of the transmission control are the shift point control, the lockup control, engine torque control during shifting, related safety functions, and diagnostic functions for vehicle service.</i>"</p> <p>E.g., page 13.9, "The basic shift point control uses shift maps, which are defined in data in the unit memory. These shift maps are selectable over a wide range. <i>The shift point limitations are made, on the one hand, by the highest admissible engine speed for each application and, on the other hand, by the lowest engine</i></p>	<p>E.g., col. 2, lines 37 to 42, "The microcomputer 5 further comprises an input/output port (I/O port) 6, a central processing unit (CPU) 7, <i>a read only memory (ROM) 8, and a random access memory (RAM) 9.</i> In the microcomputer 5, there is provided a bus BUS which communicates the I/O port 6 and the CPU 7, <i>ROM 8, and RAM 9.</i>"</p> <p>E.g., col. 3, lines 7 to 20, "<i>The torque data map indicative of torque curves T as shown in FIG. 2 has been stored in the ROM 8 in advance. The fuel consumption rate data map indicative of equal fuel consumption rate curves B as shown in FIG. 3 has been also stored in the ROM 8 in advance. In FIG. 2, each equal torque curve T was prepared by plotting and connecting equal torque points on the graph with respect to the engine speed vs. throttle valve opening. In FIG. 3, each fuel consumption rate curve B was prepared by plotting and connecting equal fuel consumption rate points on a graph obtained in advance by experiment data with respect to the engine speed and the torques thus calculated.</i>"</p> <p>E.g., col. 3, lines 44 to 61, "<i>In this case, as shown in FIG. 4, the operation of a main routine is started at a predetermined timing, e.g. periodical</i></p>	<p>E.g., col. 9, lines 3 to 8, "These sensors may include a battery voltage sensor 134, an air temperature sensor 136, an engine temperature sensor 138, <i>an engine speed sensor 140</i>, an ignition timing sensor 142, a barometric pressure sensor 144, and a throttle position sensor 146."</p> <p>E.g., FIG. 1</p>

Limitation of '781 Patent Claim 15	Automotive Electronics Handbook (Jurgen)	U.S. Patent No. 4,559,599 (Toyota '599)	U.S. Patent No. 4,901,701 (Chasteen)
	<p><i>speed that is practical for driving comfort and noise emission. The inputs of the shift point determination are the throttle position, the accelerator pedal position, and the vehicle speed (determined by the transmission output speed)."</i></p>	<p><i>timing pulses from a timer (not shown) and the detection of the engine speed <math>N_e</math> from the sensor 1 is carried out and it is stored into the RAM 9 at the step 20. Then, the engine speed <math>N_e</math> is read from the RAM 9 and it is compared with a predetermined number <math>N (=1000 \text{ rpm})</math> to determine whether or not the <math>N_e</math> exceeds the value 1000 at the step 21. If the result of the decision is YES, the next step 22 is executed. That is, in the step 22, the reading in of the opening of the throttle valve is performed through the throttle sensor 3 and the A/D converter 4. In the above case, if the result of the decision in step 21 is NO, the main routine is terminated by determining that the shift operation is not necessary and the engine speed <math>N_e</math> is read again at the predetermined timing and now the operation returns to the step 20."</i></p> <p>E.g., Figure 4:</p>	

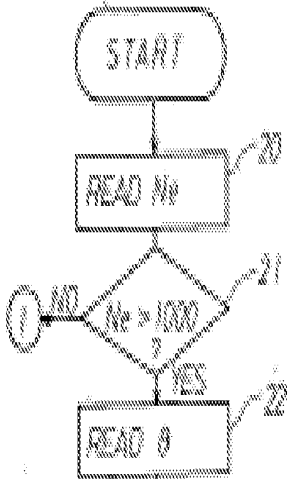

Limitation of '781 Patent Claim 15	Automotive Electronics Handbook (Jurgen)	U.S. Patent No. 4,559,599 (Toyota '599)	U.S. Patent No. 4,901,701 (Chasteen)
		 <pre> graph TD     START([START]) --&gt; READ_N1[READ N1]     READ_N1 --&gt; DEC{N1 &gt; 1000}     DEC -- YES --&gt; READ_0[READ 0]     DEC -- NO --&gt; END([END]) </pre>	
<p>said processor subsystem activating said upshift notification circuit if both road speed and throttle position for said vehicle are increasing, manifold pressure for said vehicle is at or below said manifold pressure set point and engine speed for said vehicle is at or above said RPM set point; and</p>	<p>E.g., page 13.7 to 13.9, “<i>The basic functions of the transmission control are the shift point control, the lockup control, engine torque control during shifting, related safety functions, and diagnostic functions for vehicle service.</i>”</p> <p>E.g., page 13.9, “The basic shift point control uses shift maps, which are defined in data in the unit memory. These shift maps are selectable over a wide range. <i>The shift point limitations are made, on the one hand, by the highest admissible engine speed for each application and, on the other hand, by the lowest engine speed that is practical for driving comfort and noise emission. The inputs of the shift point determination are the throttle position, the accelerator pedal position, and the vehicle speed (determined by the transmission output</i></p>	<p>E.g., col. 2, lines 37 to 42, “<i>The microcomputer 5 further comprises an input/output port (I/O port) 6, a central processing unit (CPU) 7, a read only memory (ROM) 8, and a random access memory (RAM) 9.</i> In the microcomputer 5, there is provided a bus BUS which communicates the I/O port 6 and the CPU 7, ROM 8, and RAM 9.”</p> <p>E.g., col. 2, lines 59 to 63, “<i>The input of the indicator 10 is connected to the output of the I/O port 6 so as to indicate each preferable shift position corresponding to the optimum fuel consumption rate in accordance with various parameters calculated.</i>”</p> <p>E.g., col. 5, line 63 to col. 6, line 2, “<i>Namely, in this step, the speed change operation indicating signal is applied to</i></p>	<p>E.g., col. 11, lines 22 to 33, “As indicated at 303 the CPU determines from the reading taken at 302 whether or not the engine RPM is greater than 0. If engine RPM is greater than 0, the CPU next makes the determination from the throttle position reading of 302 whether or not the throttle position is greater than a predetermined amount, such as 20°, as indicated in block 304. If throttle position is less than 20°, the CPU decision-making process returns to block 302. If the throttle position is greater than the predetermined amount and RPM = 0, the CPU provides a control command to the engine fuel injector(s) to prime the engine.”</p> <p>E.g., August 6, 1998 Office Action, “Chasteen discloses the sensors as discussed for sensing the signals and a</p>

Limitation of '781 Patent Claim 15	Automotive Electronics Handbook (Jurgen)	U.S. Patent No. 4,559,599 (Toyota '599)	U.S. Patent No. 4,901,701 (Chasteen)
	speed).”	<i>the indicator or display 10 from the microcomputer 5 through the I/O port 6. As a result, a particular lamp in this case, a shift up indicating lamp in the indicator 10, is illuminated, thus indicating to the drive that the speed change from current shift position to the one step shifting up position SP<sub>+1</sub> is preferable.”</i>	processor and compare manifold pressure for activating the fuel injection. Chasteen discloses the speed (RPM) and throttle position are determined to be greater than 0 (increasing) and the CPU provides a control command to the engine fuel injector to prime the engine (See column 11, lines 22-33) therefore on [sic] would consider increasing and decreasing the speed and throttle for adjusting the fuel injector for supplying fuel to the engine.”
said processor subsystem activating said downshift notification circuit if both road speed and engine speed are decreasing and both throttle position and manifold pressure for said vehicle are increasing.	<p>E.g., page 13.7 to 13.9, “<i>The basic functions of the transmission control are the shift point control, the lockup control, engine torque control during shifting, related safety functions, and diagnostic functions for vehicle service.</i>”</p> <p>E.g., page 13.9, “The basic shift point control uses shift maps, which are defined in data in the unit memory. These shift maps are selectable over a wide range. <i>The shift point limitations are made, on the one hand, by the highest admissible engine speed for each application and, on the other hand, by the lowest engine speed that is practical for driving comfort and noise emission. The inputs of the shift point determination are the throttle position, the accelerator pedal position, and the vehicle speed (determined by the transmission output speed).</i>”</p>	<p>E.g., col. 2, lines 37 to 42, “<i>The microcomputer 5 further comprises an input/output port (I/O port) 6, a central processing unit (CPU) 7, a read only memory (ROM) 8, and a random access memory (RAM) 9.</i> In the microcomputer 5, there is provided a bus BUS which communicates the I/O port 6 and the CPU 7, ROM 8, and RAM 9.”</p> <p>E.g., col. 2, lines 59 to 63, “<i>The input of the indicator 10 is connected to the output of the I/O port 6 so as to indicate each preferable shift position corresponding to the optimum fuel consumption rate in accordance with various parameters calculated.</i>”</p> <p>E.g., col. 5, line 63 to col. 6, line 2, “<i>Namely, in this step, the speed change operation indicating signal is applied to the indicator or display 10 from the microcomputer 5 through the I/O port 6. As a result, a particular lamp in this case, a shift up indicating lamp in the indicator 10, is illuminated, thus</i></p>	<p>E.g., col. 11, lines 22 to 33, “As indicated at 303 the CPU determines from the reading taken at 302 whether or not the engine RPM is greater than 0. If engine RPM is greater than 0, the CPU next makes the determination from the throttle position reading of 302 whether or not the throttle position is greater than a predetermined amount, such as 20°, as indicated in block 304. If throttle position is less than 20°, the CPU decision-making process returns to block 302. If the throttle position is greater than the predetermined amount and RPM = 0, the CPU provides a control command to the engine fuel injector(s) to prime the engine.”</p> <p>E.g., August 6, 1998 Office Action, “Chasteen discloses the sensors as discussed for sensing the signals and a processor and compare manifold pressure for activating the fuel injection. Chasteen discloses the speed (RPM) and throttle position are determined to be greater than 0 (increasing) and the CPU provides a</p>

Limitation of '781 Patent Claim 15	Automotive Electronics Handbook (Jurgen)	U.S. Patent No. 4,559,599 (Toyota '599)	U.S. Patent No. 4,901,701 (Chasteen)
		<p><i>indicating to the drive that the speed change from current shift position to the one step shifting up position SP<sub>+1</sub> is preferable.”</i></p> <p>E.g., col. 2, line 64 to col. 3, line 3, “<i>The indicator 10 includes a shift-up indicating lamp 10a and a shift-down indicating lamp 10b.</i></p> <p><i>The indicator 10 may be assembled by light emitting [sic] diodes (LED) so as to perform shift-up and shift-down indications by up and down directed arrow marks.</i> Alternatively, the indicator 10 may also be replaced with other voice combining circuit so as to announce the shift operations by voice instead of the indications.”</p> <p>E.g., col. 7, lines 10 to 17, “<i>In this step 42, shift-down display is performed. Namely in this case, the shift down display instruction signal from the microcomputer 5 is applied to the indicator 10 through the I/O port 6 and the shift-down indication lamp in the indicator 10 is illuminated,</i> thus indicating to the driver that speed change operation from the current shift position to the one step shifting down position SP<sub>-1</sub> is preferable.”</p> <p>E.g. col. 7, lines 29 to 38, “<i>However, only when either one of the assumed fuel consumption rates above is better than the current fuel consumption rate B<sub>0</sub>, the corresponding shift-up lamp or shift-</i></p>	<p>control command to the engine fuel injector to prime the engine (See column 11, lines 22-33) therefore on [sic] would consider increasing and decreasing the speed and throttle for adjusting the fuel injector for supplying fuel to the engine.”</p>

Limitation of '781 Patent Claim 15	Automotive Electronics Handbook (Jurgen)	U.S. Patent No. 4,559,599 (Toyota '599)	U.S. Patent No. 4,901,701 (Chasteen)
		<p><i>down lamp in the indicator 10 is illuminated, thus indicating the necessity of the speed change operation."</i></p>	

14. Claims 2, 4, 5, 8, 10, 12, and 15 are Obvious in View of the Combination of Jurgen, Volkswagen '070, and Chasteen

Limitation of '781 Patent Claim 2	Automotive Electronics Handbook (Jurgen)	German Patent Application Publication No. 29 26 070 (Volkswagen '070)	U.S. Patent No. 4,901,701 (Chasteen)
<p>2. Apparatus for optimizing operation of a vehicle according to claim 1 wherein said processor subsystem further comprises:</p>	<p>See claim 1 claim chart, at page A-31.</p>	<p>See claim 1 claim chart, at page A-31.</p>	<p>E.g., col. 1, lines 9 to 13, "The present invention relates generally to two-stroke operating cycle engines and, more particularly, to a two stroke engine fuel injection system and control system therefor which are adapted for extreme weather conditions."</p> <p>E.g., col. 2, lines 2 to 17, "Small, two-cycle engines are especially subject to malfunction under variable operating conditions such as changes in sea level, with associated barometric changes and changes in ambient air temperature. Many machines such as snowmobiles, snowblowers, dirt bikes, etc., are operated in such widely variable operating conditions. In view of the costs associated with engine modification for sensors' need for electronic control of fuel injectors and in view of the fact that the engine parameters which are critical to control of fuel injectors for two-cycle engines were not, prior to the present invention, understood in the art, a successful electronically-controlled fuel injection system for small, two-cycle engines which are subject to extremes in operating conditions has not been developed in the prior art."</p>
<p>means for determining when road speed for said vehicle is increasing;</p>	<p>E.g., page 7.6, "There are several applications for rotational speed sensing. First it is necessary to monitor engine speed. This information is used for transmission control, engine control, cruise control, and possibly for a tachometer. Electronics and electronic sensing in the automobile were brought</p>		

Limitation of '781 Patent Claim 2	Automotive Electronics Handbook (Jurgen)	German Patent Application Publication No. 29 26 070 (Volkswagen '070)	U.S. Patent No. 4,901,701 (Chasteen)
	<p>about by the need for higher efficiency engines, better fuel economy, increased power and performance, and lower emissions. Second, <i>wheel speed sensing is required</i> for use in transmissions, cruise control, speedometers, antilock brake systems (ABS), traction control (ASR), variable ratio power steering assist, four-wheel steering, and possibly in inertial navigation and air bag deployment applications.”</p> <p>E.g., page 7.8, “In electronic transmission applications, <i>information from the road and engine speed sensors</i>, as well as torque data and throttle position are required for the MCU to select the optimum gear ratio.”</p>		
<p>means for determining when throttle position for said vehicle is increasing; and</p>	<p>E.g., page 12.18, “To control the idle speed, the ECU uses inputs from the <i>throttle position sensor</i>, air conditioning, automatic transmission, power steering, charging system, engine RPM, and vehicle speed.”</p> <p>E.g., page 12.21, “The electronic injection unit also houses the <i>throttle position sensor</i> and, in some cases, an inlet air temperature sensor which provides operating condition information to the ECU.”</p>	<p>E.g., page 6 (English translation), “As can be seen when viewing Figure 1 to begin with, output N of the engine has been plotted across engine speed n. a is the curve of the output at full load, b is a line that represents a constant setting of the output control element, i.e., a line that represents a constant <i>throttle valve angle</i> in a carburetor engine.”</p>	<p>E.g., col. 9, lines 3 to 8, “These sensors may include a battery voltage sensor 134, an air temperature sensor 136, an engine temperature sensor 138, an engine speed sensor 140, an ignition timing sensor 142, a barometric pressure sensor 144, and a <i>throttle position sensor 146</i>.”</p> <p>E.g., FIG. 1</p>
<p>means for comparing manifold pressure to said manifold pressure set point;</p>	<p>E.g., page 12.1, “The electronic engine control system consists of <i>sensing devices which continuously measure the operating conditions of the engine, an</i></p>	<p>E.g., page 6 (English translation), “As can be seen when viewing Figure 1 to begin with, output N of the engine has been plotted across</p>	

Limitation of '781 Patent Claim 2	Automotive Electronics Handbook (Jurgen)	German Patent Application Publication No. 29 26 070 (Volkswagen '070)	U.S. Patent No. 4,901,701 (Chasteen)
	<p><i>electronic control unit (ECU) which evaluates the sensor inputs</i> using data tables and calculations and determines the output to the actuating devices, and actuating devices which are commanded by the ECU to perform an action in response to the sensor inputs.”</p> <p>E.g., page 22.6, “During the entire operating time of the vehicle, <i>the ECUs are constantly supervising the sensors they are connected to.</i>”</p> <p>E.g., page 13.4, “On the functional side, the hardware configuration can be divided into power supply, input signal transfer circuits, output stages, and <i>microcontroller</i>, including peripheral components and monitoring and safety circuits (Fig. 13.1).”</p>	<p>engine speed <i>n</i>. <i>a</i> is the curve of the output at full load, <i>b</i> is a line that represents a constant setting of the output control element, i.e., a line that represents a constant throttle valve angle in a carburetor engine. As a measure thereof, in addition to the throttle valve angle itself, it is also possible to use the <i>induction manifold vacuum.</i>”</p> <p>E.g., page 9 (English translation), “It is useful if in addition to this device, a display of the route-specific fuel consumption is provided in a vehicle. Such display devices are known per se; they generally utilize the <i>injection manifold vacuum</i> as a measure of fuel consumption.”</p>	
<p>said processor subsystem activating said fuel overinjection notification circuit if both road speed and throttle position for said vehicle are increasing and manifold pressure for said vehicle is above said manifold pressure set point.</p>	<p>E.g., page 12.4, “During coasting and braking, fuel consumption can be further reduced by shutting off the fuel until the engine speed decreases to slightly higher than the set idle speed. <i>The ECU determines when fuel shutoff can occur by evaluating the throttle position, engine RPM, and vehicle speed.</i>”</p> <p>E.g., page 12.14, “Using the inputs of engine RPM and vehicle speed to the electronic control unit, thresholds can be established for limiting these variables with fuel cutoff. <i>When the maximum speed is achieved, the fuel injectors are shut off.</i> When the speed decreases below</p>	<p>E.g., page 9 (English translation), “It is useful if in addition to this device, <i>a display of the route-specific fuel consumption is provided in a vehicle.</i> Such display devices are known per se; they generally utilize the injection manifold vacuum as a measure of fuel consumption.”</p>	<p>E.g., col. 9, lines 1 to 8, “The electronic control assembly comprises a number of sensors having sensor outputs which are provided to the CPU 130 through interface circuitry 132. These sensors may include a battery voltage sensor 134, an air temperature sensor 136, an engine temperature sensor 138, an engine speed sensor 140, an ignition timing sensor 142, a barometric pressure sensor 144, and a throttle position sensor 146.”</p> <p>E.g., col. 9, lines 48 to 55, “The CPU 130 receives and processes the signals from the various sensors described above and generates control signals which are used to control fuel pump speed, to maintain the speed of operation</p>

Limitation of '781 Patent Claim 2	Automotive Electronics Handbook (Jurgen)	German Patent Application Publication No. 29 26 070 (Volkswagen '070)	U.S. Patent No. 4,901,701 (Chasteen)
	<p>the threshold, fuel injection resumes.”</p>		<p>of the fuel pump at a rate which provides a pressure in the circulation conduit portion immediately downstream therefrom which is approximately equal to the preset maximum pressure of the pressure regulator 114.”</p> <p>E.g., col. 11, lines 22 to 33, “As indicated at 303 the CPU determines from the reading taken at 302 whether or not the engine RPM is greater than 0. If engine RPM is greater than 0, the CPU next makes the determination from the throttle position reading of 302 whether or not the throttle position is greater than a predetermined amount, such as 20°, as indicated in block 304. If throttle position is less than 20°, the CPU decision-making process returns to block 302. If the throttle position is greater than the predetermined amount and RPM = 0, the CPU provides a control command to the engine fuel injector(s) to prime the engine.”</p> <p>E.g., August 6, 1998 Office Action, “Chasteen discloses the sensors as discussed for sensing the signals and a processor and compare manifold pressure for activating the fuel injection. Chasteen discloses the speed (RPM) and throttle position are determined to be greater than 0 (increasing) and the CPU provides a control command to the engine fuel injector to prime the engine (See column 11, lines 22-33) therefore on [sic] would consider increasing and decreasing the speed and throttle for adjusting the fuel injector for supplying fuel to the engine.”</p>



Limitation of '781 Patent Claim 4	Automotive Electronics Handbook (Jurgen)	German Patent Application Publication No. 29 26 070 (Volkswagen '070)	U.S. Patent No. 4,901,701 (Chasteen)
<p>4. Apparatus for optimizing operation of a vehicle according to claim 1 wherein said processor subsystem further comprises:</p>	<p>See claim 1 claim chart, at page A-31.</p>	<p>See claim 1 claim chart, at page A-31.</p>	<p>E.g., col. 1, lines 9 to 13, "The present invention relates generally to two-stroke operating cycle engines and, more particularly, to a two stroke engine fuel injection system and control system therefor which are adapted for extreme weather conditions."</p> <p>E.g., col. 2, lines 2 to 17, "Small, two-cycle engines are especially subject to malfunction under variable operating conditions such as changes in sea level, with associated barometric changes and changes in ambient air temperature. Many machines such as snowmobiles, snowblowers, dirt bikes, etc., are operated in such widely variable operating conditions. In view of the costs associated with engine modification for sensors' need for electronic control of fuel injectors and in view of the fact that the engine parameters which are critical to control of fuel injectors for two-cycle engines were not, prior to the present invention, understood in the art, a successful electronically-controlled fuel injection system for small, two-cycle engines which are subject to extremes in operating conditions has not been developed in the prior art."</p>
<p>means for determining when road speed for said vehicle is decreasing;</p>	<p>E.g., page 7.6, "There are several applications for rotational speed sensing. First it is necessary to monitor engine speed. This information is used for transmission control, engine control, cruise control, and possibly for a tachometer. Electronics and electronic</p>		

Limitation of '781 Patent Claim 4	Automotive Electronics Handbook (Jurgen)	German Patent Application Publication No. 29 26 070 (Volkswagen '070)	U.S. Patent No. 4,901,701 (Chasteen)
	<p>sensing in the automobile were brought about by the need for higher efficiency engines, better fuel economy, increased power and performance, and lower emissions. Second, <i>wheel speed sensing is required</i> for use in transmissions, cruise control, speedometers, antilock brake systems (ABS), traction control (ASR), variable ratio power steering assist, four-wheel steering, and possibly in inertial navigation and air bag deployment applications.”</p> <p>E.g., page 7.8, “In electronic transmission applications, <i>information from the road and engine speed sensors</i>, as well as torque data and throttle position are required for the MCU to select the optimum gear ratio.”</p>		
<p>means for determining when throttle position for said vehicle is increasing;</p>	<p>E.g., page 12.18, “To control the idle speed, the ECU uses inputs from the <i>throttle position sensor</i>, air conditioning, automatic transmission, power steering, charging system, engine RPM, and vehicle speed.”</p> <p>E.g., page 12.21, “The electronic injection unit also houses the <i>throttle position sensor</i> and, in some cases, an inlet air temperature sensor which provides operating condition information to the ECU.”</p>	<p>E.g., page 6 (English translation), “As can be seen when viewing Figure 1 to begin with, output N of the engine has been plotted across engine speed n. a is the curve of the output at full load, b is a line that represents a constant setting of the output control element, i.e., a line that represents a constant <i>throttle valve angle</i> in a carburetor engine.”</p>	<p>E.g., col. 9, lines 3 to 8, “These sensors may include a battery voltage sensor 134, an air temperature sensor 136, an engine temperature sensor 138, an engine speed sensor 140, an ignition timing sensor 142, a barometric pressure sensor 144, and a <i>throttle position sensor 146</i>.”</p> <p>E.g., FIG. 1</p>
<p>means for determining when manifold pressure for said vehicle is increasing; and</p>	<p>E.g., page 2.5, “Automotive specification and testing guidelines have been developed and published by the Society of Automotive Engineers (SAE) specifically for <i>manifold absolute</i></p>	<p>E.g., page 6 (English translation), “As can be seen when viewing Figure 1 to begin with, output N of the engine has been plotted across engine speed n. a is the curve of the output at full load, b is a line</p>	

Limitation of '781 Patent Claim 4	Automotive Electronics Handbook (Jurgen)	German Patent Application Publication No. 29 26 070 (Volkswagen '070)	U.S. Patent No. 4,901,701 (Chasteen)
	<p><i>pressure (MAP) sensors.</i></p> <p>E.g., page 2.7, "Manifold absolute pressure (MAP) is used as an input to fuel and ignition control in internal combustion engine control systems. <i>The speed-density system that uses the MAP sensor</i> has been preferred over mass air flow (MAF) control because it's less expensive, but stricter emission standards are causing more manufacturers to use mass air flow for future models."</p>	<p>that represents a constant setting of the output control element, i.e., a line that represents a constant throttle valve angle in a carburetor engine. As a measure thereof, in addition to the throttle valve angle itself, it is also possible to use the <i>induction manifold vacuum.</i></p> <p>E.g., page 9 (English translation), "It is useful if in addition to this device, a display of the route-specific fuel consumption is provided in a vehicle. Such display devices are known per se; they generally utilize the <i>injection manifold vacuum</i> as a measure of fuel consumption."</p>	
<p>means for determining when engine speed for said vehicle is decreasing;</p>	<p>E.g., page 7.6, "There are several applications for rotational speed sensing. <i>First it is necessary to monitor engine speed.</i> This information is used for transmission control, engine control, cruise control, and possibly for a tachometer. Electronics and electronic sensing in the automobile were brought about by the need for higher efficiency engines, better fuel economy, increased power and performance, and lower emissions. Second, wheel speed sensing is required for use in transmissions, cruise control, speedometers, antilock brake systems (ABS), traction control (ASR), variable ratio power steering assist, four-wheel steering, and possibly in inertial navigation and air bag deployment applications."</p>	<p>E.g., page 6 (English translation), "The operating ranges I and II are further delimited by <i>engine speed</i> values <math>n_1</math> or <math>n_2</math>, the first of which usually lies between approximately 20 to 50% of the maximum engine speed, and the second usually lies between approximately 40 and 70% of the maximum engine speed."</p> <p>E.g., page 8 (English translation), "<i>The engine speed signal is obtained with the aid of known sensor systems</i>, which therefore need not be described in further detail here."</p>	<p>E.g., col. 9, lines 3 to 8, "These sensors may include a battery voltage sensor 134, an air temperature sensor 136, an engine temperature sensor 138, <i>an engine speed sensor 140</i>, an ignition timing sensor 142, a barometric pressure sensor 144, and a throttle position sensor 146."</p> <p>E.g., FIG. 1</p>

Limitation of '781 Patent Claim 4	Automotive Electronics Handbook (Jurgen)	German Patent Application Publication No. 29 26 070 (Volkswagen '070)	U.S. Patent No. 4,901,701 (Chasteen)
	<p>E.g., page 7.8, "In electronic transmission applications, <i>information from the road and engine speed sensors</i>, as well as torque data and throttle position are required for the MCU to select the optimum gear ratio."</p>		
<p>said processor subsystem activating said fuel overinjection notification circuit if both throttle position and manifold pressure for said vehicle are increasing and road speed and engine speed for said vehicle are decreasing.</p>	<p>E.g., page 12.4, "During coasting and braking, fuel consumption can be further reduced by shutting off the fuel until the engine speed decreases to slightly higher than the set idle speed. <i>The ECU determines when fuel shutoff can occur by evaluating the throttle position, engine RPM, and vehicle speed.</i>"</p> <p>E.g., page 12.14, "Using the inputs of engine RPM and vehicle speed to the electronic control unit, thresholds can be established for limiting these variables with fuel cutoff. <i>When the maximum speed is achieved, the fuel injectors are shut off.</i> When the speed decreases below the threshold, fuel injection resumes."</p>	<p>E.g., page 9 (English translation), "It is useful if in addition to this device, <i>a display of the route-specific fuel consumption is provided in a vehicle.</i> Such display devices are known per se; they generally utilize the injection manifold vacuum as a measure of fuel consumption."</p>	<p>E.g., col. 9, lines 1 to 8, "The electronic control assembly comprises a number of sensors having sensor outputs which are provided to the CPU 130 through interface circuitry 132. These sensors may include a battery voltage sensor 134, an air temperature sensor 136, an engine temperature sensor 138, an engine speed sensor 140, an ignition timing sensor 142, a barometric pressure sensor 144, and a throttle position sensor 146."</p> <p>E.g., col. 9, lines 48 to 55, "The CPU 130 receives and processes the signals from the various sensors described above and generates control signals which are used to control fuel pump speed, to maintain the speed of operation of the fuel pump at a rate which provides a pressure in the circulation conduit portion immediately downstream therefrom which is approximately equal to the preset maximum pressure of the pressure regulator 114."</p> <p>E.g., col. 11, lines 22 to 33, "As indicated at 303 the CPU determines from the reading taken at 302 whether or not the engine RPM is greater than 0. If engine RPM is greater than 0, the CPU next makes the determination from the throttle</p>

Limitation of '781 Patent Claim 4	Automotive Electronics Handbook (Jurgen)	German Patent Application Publication No. 29 26 070 (Volkswagen '070)	U.S. Patent No. 4,901,701 (Chasteen)
			<p>position reading of 302 whether or not the throttle position is greater than a predetermined amount, such as 20°, as indicated in block 304. If throttle position is less than 20°, the CPU decision-making process returns to block 302. If the throttle position is greater than the predetermined amount and RPM = 0, the CPU provides a control command to the engine fuel injector(s) to prime the engine.”</p> <p>E.g., August 6, 1998 Office Action, “Chasteen discloses the sensors as discussed for sensing the signals and a processor and compare manifold pressure for activating the fuel injection. Chasteen discloses the speed (RPM) and throttle position are determined to be greater than 0 (increasing) and the CPU provides a control command to the engine fuel injector to prime the engine (See column 11, lines 22-33) therefore on [sic] would consider increasing and decreasing the speed and throttle for adjusting the fuel injector for supplying fuel to the engine.”</p>

Limitation of '781 Patent Claim 5	Automotive Electronics Handbook (Jurgen)	German Patent Application Publication No. 29 26 070 (Volkswagen '070)	U.S. Patent No. 4,901,701 (Chasteen)
<p>5. Apparatus for optimizing operation of a vehicle according to claim 1 wherein said processor subsystem further comprises:</p>	<p>See claim 1 claim chart, at page A-31.</p>	<p>See claim 1 claim chart, at page A-31.</p>	<p>E.g., col. 1, lines 9 to 13, "The present invention relates generally to two-stroke operating cycle engines and, more particularly, to a two stroke engine fuel injection system and control system therefor which are adapted for extreme weather conditions."</p> <p>E.g., col. 2, lines 2 to 17, "Small, two-cycle engines are especially subject to malfunction under variable operating conditions such as changes in sea level, with associated barometric changes and changes in ambient air temperature. Many machines such as snowmobiles, snowblowers, dirt bikes, etc., are operated in such widely variable operating conditions. In view of the costs associated with engine modification for sensors' need for electronic control of fuel injectors and in view of the fact that the engine parameters which are critical to control of fuel injectors for two-cycle engines were not, prior to the present invention, understood in the art, a successful electronically-controlled fuel injection system for small, two-cycle engines which are subject to extremes in operating conditions has not been developed in the prior art."</p>
<p>means for determining when road speed for said vehicle is increasing;</p>	<p>E.g., page 7.6, "There are several applications for rotational speed sensing. First it is necessary to monitor engine speed. This information is used for transmission control, engine control, cruise control, and possibly for a tachometer. Electronics and electronic</p>		

Limitation of '781 Patent Claim 5	Automotive Electronics Handbook (Jurgen)	German Patent Application Publication No. 29 26 070 (Volkswagen '070)	U.S. Patent No. 4,901,701 (Chasteen)
	<p>sensing in the automobile were brought about by the need for higher efficiency engines, better fuel economy, increased power and performance, and lower emissions. Second, <i>wheel speed sensing is required</i> for use in transmissions, cruise control, speedometers, antilock brake systems (ABS), traction control (ASR), variable ratio power steering assist, four-wheel steering, and possibly in inertial navigation and air bag deployment applications.”</p> <p>E.g., page 7.8, “In electronic transmission applications, <i>information from the road and engine speed sensors</i>, as well as torque data and throttle position are required for the MCU to select the optimum gear ratio.”</p>		
<p>means for determining when throttle position for said vehicle is increasing;</p>	<p>E.g., page 12.18, “To control the idle speed, the ECU uses inputs from the <i>throttle position sensor</i>, air conditioning, automatic transmission, power steering, charging system, engine RPM, and vehicle speed.”</p> <p>E.g., page 12.21, “The electronic injection unit also houses the <i>throttle position sensor</i> and, in some cases, an inlet air temperature sensor which provides operating condition information to the ECU.”</p>	<p>E.g., page 6 (English translation), “As can be seen when viewing Figure 1 to begin with, output N of the engine has been plotted across engine speed n. a is the curve of the output at full load, b is a line that represents a constant setting of the output control element, i.e., a line that represents a constant <i>throttle valve angle</i> in a carburetor engine.”</p>	<p>E.g., col. 9, lines 3 to 8, “These sensors may include a battery voltage sensor 134, an air temperature sensor 136, an engine temperature sensor 138, an engine speed sensor 140, an ignition timing sensor 142, a barometric pressure sensor 144, and a <i>throttle position sensor 146</i>.”</p> <p>E.g., FIG. 1</p>
<p>means for comparing manifold pressure to said manifold pressure set point; and</p>	<p>E.g., page 12.1, “The electronic engine control system consists of <i>sensing devices which continuously measure the operating conditions of the engine, an electronic control unit (ECU) which</i></p>	<p>E.g., page 6 (English translation), “As can be seen when viewing Figure 1 to begin with, output N of the engine has been plotted across engine speed n. a is the curve of the output at full load, b is a line</p>	

Limitation of '781 Patent Claim 5	Automotive Electronics Handbook (Jurgen)	German Patent Application Publication No. 29 26 070 (Volkswagen '070)	U.S. Patent No. 4,901,701 (Chasteen)
	<p><i>evaluates the sensor inputs</i> using data tables and calculations and determines the output to the actuating devices, and actuating devices which are commanded by the ECU to perform an action in response to the sensor inputs.”</p> <p>E.g., page 22.6, “During the entire operating time of the vehicle, <i>the ECUs are constantly supervising the sensors they are connected to.</i>”</p> <p>E.g., page 13.4, “On the functional side, the hardware configuration can be divided into power supply, input signal transfer circuits, output stages, and <i>microcontroller</i>, including peripheral components and monitoring and safety circuits (Fig. 13.1).”</p>	<p>that represents a constant setting of the output control element, i.e., a line that represents a constant throttle valve angle in a carburetor engine. As a measure thereof, in addition to the throttle valve angle itself, it is also possible to use the <i>induction manifold vacuum.</i>”</p> <p>E.g., page 9 (English translation), “It is useful if in addition to this device, a display of the route-specific fuel consumption is provided in a vehicle. Such display devices are known per se; they generally utilize the <i>injection manifold vacuum</i> as a measure of fuel consumption.”</p>	
<p>means for comparing engine speed to said RPM set point;</p>	<p>E.g., page 13.7 to 13.9, “<i>The basic functions of the transmission control are the shift point control</i>, the lockup control, engine torque control during shifting, related safety functions, and diagnostic functions for vehicle service.”</p> <p>E.g., page 13.9, “The basic shift point control uses shift maps, which are defined in data in the unit memory. These shift maps are selectable over a wide range. <i>The shift point limitations are made</i>, on the one hand, by the highest admissible engine speed for each application and, on the other hand, <i>by the lowest engine speed that is practical for driving comfort and noise emission. The inputs of the shift point determination are the</i></p>	<p>E.g., pages 6 to 7 (English translation), “Looking initially at operating range I remote from full load, <i>the desired output at a lower specific fuel consumption is able to be achieved after upshifting into the next higher gear</i>, at an operating point that lies to the left of operating range I in the diagram of Figure 1. <i>Accordingly, the device of the present invention generates a signal that asks the operator, i.e., normally the driver, to shift to a higher gear, which is indicated in Figure 1 by the upward pointing arrow within operating range I.</i>”</p> <p>E.g., pages 7 to 8 (English translation), “The two control circuits 2 and 3 are selectively closed by engine-speed</p>	<p>E.g., col. 11, lines 22 to 33, “<i>As indicated at 303 the CPU determines from the reading taken at 302 whether or not the engine RPM is greater than 0.</i> If engine RPM is greater than 0, the CPU next makes the determination from the throttle position reading of 302 whether or not the throttle position is greater than a predetermined amount, such as 20°, as indicated in block 304. If throttle position is less than 20°, the CPU decision-making process returns to block 302. <i>If the throttle position is greater than the predetermined amount and RPM = 0, the CPU provides a control command to the engine fuel injector(s) to prime the engine.</i>”</p>

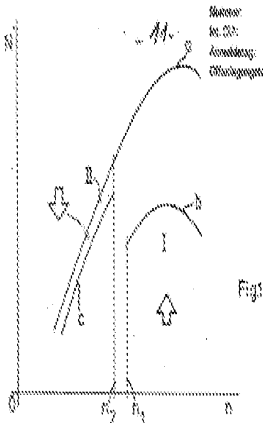

Limitation of '781 Patent Claim 5	Automotive Electronics Handbook (Jurgen)	German Patent Application Publication No. 29 26 070 (Volkswagen '070)	U.S. Patent No. 4,901,701 (Chasteen)
	<p><i>throttle position, the accelerator pedal position, and the vehicle speed (determined by the transmission output speed)."</i></p>	<p>dependent change-over switch 6, to which a signal that corresponds to the individual engine speed <math>n</math> is forwarded and which is developed in such a way that <i>at engine speeds that are greater than predefined engine speed <math>n_1</math> (see Figure 1), its shift lever pivots upwardly in Figure 2, but at engine speeds that are smaller than predefined engine speed <math>n_2</math>, it pivots in the downward direction from a neutral center position, which it therefore assumes when engine speed values between <math>n_1</math> and <math>n_2</math> are present."</i></p> <p>E.g., Figure 1:</p>  <p>E.g., Figure 2:</p>	

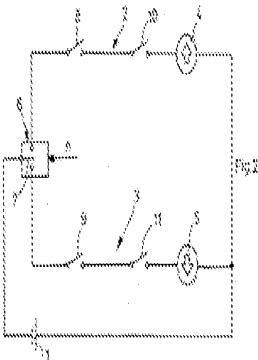
Limitation of '781 Patent Claim 5	Automotive Electronics Handbook (Jurgen)	German Patent Application Publication No. 29 26 070 (Volkswagen '070)	U.S. Patent No. 4,901,701 (Chasteen)
			
<p>said processor subsystem activating said upshift notification circuit if both road speed and throttle position for said vehicle are increasing, manifold pressure for said vehicle is at or below said manifold pressure set point and engine speed for said vehicle is at or above said RPM set point.</p>	<p>E.g., page 13.7 to 13.9, “<i>The basic functions of the transmission control are the shift point control, the lockup control, engine torque control during shifting, related safety functions, and diagnostic functions for vehicle service.</i>”</p> <p>E.g., page 13.9, “The basic shift point control uses shift maps, which are defined in data in the unit memory. These shift maps are selectable over a wide range. <i>The shift point limitations are made, on the one hand, by the highest admissible engine speed for each application and, on the other hand, by the lowest engine speed that is practical for driving comfort and noise emission. The inputs of the shift point determination are the throttle position, the accelerator pedal position, and the vehicle speed (determined by the transmission output speed).</i>”</p>	<p>E.g., pages 6 to 7 (English translation), “Looking initially at operating range I remote from full load, <i>the desired output at a lower specific fuel consumption is able to be achieved after upshifting into the next higher gear</i>, at an operating point that lies to the left of operating range I in the diagram of Figure 1. <i>Accordingly, the device of the present invention generates a signal that asks the operator, i.e., normally the driver, to shift to a higher gear, which is indicated in Figure 1 by the upward pointing arrow within operating range I.</i>”</p> <p>E.g., pages 7 to 8 (English translation), “The two control circuits 2 and 3 are selectively closed by engine-speed dependent change-over switch 6, to which a signal that corresponds to the individual engine speed <math>n</math> is forwarded and which is developed in such a way that <i>at engine speeds that are greater than predefined engine speed <math>n_1</math> (see Figure 1), its shift lever pivots upwardly in Figure 2, but at engine speeds that are smaller than</i></p>	<p>E.g., col. 9, lines 1 to 8, “The electronic control assembly comprises a number of sensors having sensor outputs which are provided to the CPU 130 through interface circuitry 132. These sensors may include a battery voltage sensor 134, an air temperature sensor 136, an engine temperature sensor 138, an engine speed sensor 140, an ignition timing sensor 142, a barometric pressure sensor 144, and a throttle position sensor 146.”</p> <p>E.g., col. 9, lines 48 to 55, “The CPU 130 receives and processes the signals from the various sensors described above and generates control signals which are used to control fuel pump speed, to maintain the speed of operation of the fuel pump at a rate which provides a pressure in the circulation conduit portion immediately downstream therefrom which is approximately equal to the preset maximum pressure of the pressure regulator 114.”</p> <p>E.g., col. 11, lines 22 to 33, “As indicated</p>

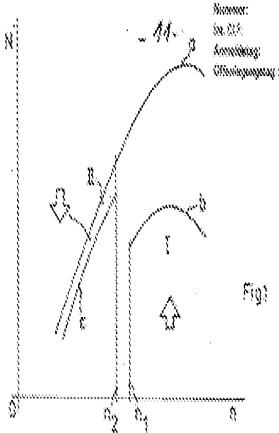
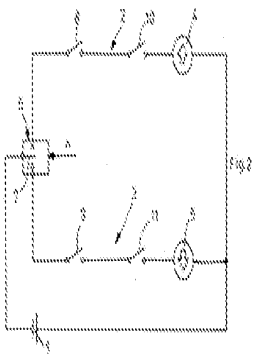
Limitation of '781 Patent Claim 5	Automotive Electronics Handbook (Jurgen)	German Patent Application Publication No. 29 26 070 (Volkswagen '070)	U.S. Patent No. 4,901,701 (Chasteen)
		<p><i>predefined engine speed <math>n_2</math>, it pivots in the downward direction from a neutral center position, which it therefore assumes when engine speed values between <math>n_1</math> and <math>n_2</math> are present."</i></p> <p>E.g., Figure 1:</p>  <p>E.g., Figure 2:</p> 	<p>at 303 the CPU determines from the reading taken at 302 whether or not the engine RPM is greater than 0. If engine RPM is greater than 0, the CPU next makes the determination from the throttle position reading of 302 whether or not the throttle position is greater than a predetermined amount, such as 20°, as indicated in block 304. If throttle position is less than 20°, the CPU decision-making process returns to block 302. If the throttle position is greater than the predetermined amount and RPM = 0, the CPU provides a control command to the engine fuel injector(s) to prime the engine."</p> <p>E.g., August 6, 1998 Office Action, "Chasteen discloses the sensors as discussed for sensing the signals and a processor and compare manifold pressure for activating the fuel injection. Chasteen discloses the speed (RPM) and throttle position are determined to be greater than 0 (increasing) and the CPU provides a control command to the engine fuel injector to prime the engine (See column 11, lines 22-33) therefore on [sic] would consider increasing and decreasing the speed and throttle for adjusting the fuel injector for supplying fuel to the engine."</p>

Limitation of '781 Patent Claim 8	Automotive Electronics Handbook (Jurgen)	German Patent Application Publication No. 29 26 070 (Volkswagen '070)	U.S. Patent No. 4,901,701 (Chasteen)
8. Apparatus for optimizing operation of a vehicle according to claim 7 wherein said processor subsystem further comprises:	See claim 7 claim chart, at page A-39.	See claim 7 claim chart, at page A-39.	<p>E.g., col. 1, lines 9 to 13, "The present invention relates generally to two-stroke operating cycle engines and, more particularly, to a two stroke engine fuel injection system and control system therefor which are adapted for extreme weather conditions."</p> <p>E.g., col. 2, lines 2 to 17, "Small, two-cycle engines are especially subject to malfunction under variable operating conditions such as changes in sea level, with associated barometric changes and changes in ambient air temperature. Many machines such as snowmobiles, snowblowers, dirt bikes, etc., are operated in such widely variable operating conditions. In view of the costs associated with engine modification for sensors' need for electronic control of fuel injectors and in view of the fact that the engine parameters which are critical to control of fuel injectors for two-cycle engines were not, prior to the present invention, understood in the art, a successful electronically-controlled fuel injection system for small, two-cycle engines which are subject to extremes in operating conditions has not been developed in the prior art."</p>
means for determining when road speed for said vehicle is increasing;	E.g., page 7.6, "There are several applications for rotational speed sensing. First it is necessary to monitor engine speed. This information is used for transmission control, engine control, cruise control, and possibly for a		

Limitation of '781 Patent Claim 8	Automotive Electronics Handbook (Jurgen)	German Patent Application Publication No. 29 26 070 (Volkswagen '070)	U.S. Patent No. 4,901,701 (Chasteen)
	<p>tachometer. Electronics and electronic sensing in the automobile were brought about by the need for higher efficiency engines, better fuel economy, increased power and performance, and lower emissions. Second, <i>wheel speed sensing is required</i> for use in transmissions, cruise control, speedometers, antilock brake systems (ABS), traction control (ASR), variable ratio power steering assist, four-wheel steering, and possibly in inertial navigation and air bag deployment applications.”</p> <p>E.g., page 7.8, “In electronic transmission applications, <i>information from the road and engine speed sensors</i>, as well as torque data and throttle position are required for the MCU to select the optimum gear ratio.”</p>		
<p>means for determining when throttle position for said vehicle is increasing;</p>	<p>E.g., page 12.18, “To control the idle speed, the ECU uses inputs from the <i>throttle position sensor</i>, air conditioning, automatic transmission, power steering, charging system, engine RPM, and vehicle speed.”</p> <p>E.g., page 12.21, “The electronic injection unit also houses the <i>throttle position sensor</i> and, in some cases, an inlet air temperature sensor which provides operating condition information to the ECU.”</p>	<p>E.g., page 6 (English translation), “As can be seen when viewing Figure 1 to begin with, output N of the engine has been plotted across engine speed n. a is the curve of the output at full load, b is a line that represents a constant setting of the output control element, i.e., a line that represents a constant <i>throttle valve angle</i> in a carburetor engine.”</p>	<p>E.g., col. 9, lines 3 to 8, “These sensors may include a battery voltage sensor 134, an air temperature sensor 136, an engine temperature sensor 138, an engine speed sensor 140, an ignition timing sensor 142, a barometric pressure sensor 144, and a <i>throttle position sensor 146</i>.”</p> <p>E.g., FIG. 1</p>
<p>means for comparing manifold pressure to said manifold pressure set point; and</p>	<p>E.g., page 12.1, “The electronic engine control system consists of <i>sensing devices which continuously measure the operating conditions of the engine, an</i></p>	<p>E.g., page 6 (English translation), “As can be seen when viewing Figure 1 to begin with, output N of the engine has been plotted across engine speed n. a is the</p>	

Limitation of '781 Patent Claim 8	Automotive Electronics Handbook (Jurgen)	German Patent Application Publication No. 29 26 070 (Volkswagen '070)	U.S. Patent No. 4,901,701 (Chasteen)
	<p><i>electronic control unit (ECU) which evaluates the sensor inputs</i> using data tables and calculations and determines the output to the actuating devices, and actuating devices which are commanded by the ECU to perform an action in response to the sensor inputs.”</p> <p>E.g., page 22.6, “During the entire operating time of the vehicle, <i>the ECUs are constantly supervising the sensors they are connected to.</i>”</p> <p>E.g., page 13.4, “On the functional side, the hardware configuration can be divided into power supply, input signal transfer circuits, output stages, and <i>microcontroller</i>, including peripheral components and monitoring and safety circuits (Fig. 13.1).”</p>	<p>curve of the output at full load, b is a line that represents a constant setting of the output control element, i.e., a line that represents a constant throttle valve angle in a carburetor engine. As a measure thereof, in addition to the throttle valve angle itself, it is also possible to use the <i>induction manifold vacuum.</i>”</p> <p>E.g., page 9 (English translation), “It is useful if in addition to this device, a display of the route-specific fuel consumption is provided in a vehicle. Such display devices are known per se; they generally utilize the <i>injection manifold vacuum</i> as a measure of fuel consumption.”</p>	
<p>said processor subsystem activating said fuel overinjection notification circuit if both road speed and throttle position for said vehicle are increasing and manifold pressure for said vehicle is above said manifold pressure set point.</p>	<p>E.g., page 12.4, “During coasting and braking, fuel consumption can be further reduced by shutting off the fuel until the engine speed decreases to slightly higher than the set idle speed. <i>The ECU determines when fuel shutoff can occur by evaluating the throttle position, engine RPM, and vehicle speed.</i>”</p> <p>E.g., page 12.14, “Using the inputs of engine RPM and vehicle speed to the electronic control unit, thresholds can be established for limiting these variables with fuel cutoff. <i>When the maximum speed is achieved, the fuel injectors are shut off.</i> When the speed decreases below the threshold, fuel injection resumes.”</p>	<p>E.g., page 9 (English translation), “It is useful if in addition to this device, <i>a display of the route-specific fuel consumption is provided in a vehicle.</i> Such display devices are known per se; they generally utilize the injection manifold vacuum as a measure of fuel consumption.”</p>	<p>E.g., col. 9, lines 1 to 8, “The electronic control assembly comprises a number of sensors having sensor outputs which are provided to the CPU 130 through interface circuitry 132. These sensors may include a battery voltage sensor 134, an air temperature sensor 136, an engine temperature sensor 138, an engine speed sensor 140, an ignition timing sensor 142, a barometric pressure sensor 144, and a throttle position sensor 146.”</p> <p>E.g., col. 9, lines 48 to 55, “The CPU 130 receives and processes the signals from the various sensors described above and generates control signals which are used to control fuel pump speed, to maintain</p>

Limitation of '781 Patent Claim 8	Automotive Electronics Handbook (Jurgen)	German Patent Application Publication No. 29 26 070 (Volkswagen '070)	U.S. Patent No. 4,901,701 (Chasteen)
			<p>the speed of operation of the fuel pump at a rate which provides a pressure in the circulation conduit portion immediately downstream therefrom which is approximately equal to the preset maximum pressure of the pressure regulator 114.”</p> <p>E.g., col. 11, lines 22 to 33, “As indicated at 303 the CPU determines from the reading taken at 302 whether or not the engine RPM is greater than 0. If engine RPM is greater than 0, the CPU next makes the determination from the throttle position reading of 302 whether or not the throttle position is greater than a predetermined amount, such as 20°, as indicated in block 304. If throttle position is less than 20°, the CPU decision-making process returns to block 302. If the throttle position is greater than the predetermined amount and RPM = 0, the CPU provides a control command to the engine fuel injector(s) to prime the engine.”</p> <p>E.g., August 6, 1998 Office Action, “Chasteen discloses the sensors as discussed for sensing the signals and a processor and compare manifold pressure for activating the fuel injection. Chasteen discloses the speed (RPM) and throttle position are determined to be greater than 0 (increasing) and the CPU provides a control command to the engine fuel injector to prime the engine (See column 11, lines 22-33) therefore on [sic] would consider increasing and decreasing the</p>

Limitation of '781 Patent Claim 8	Automotive Electronics Handbook (Jurgen)	German Patent Application Publication No. 29 26 070 (Volkswagen '070)	U.S. Patent No. 4,901,701 (Chasteen)
			speed and throttle for adjusting the fuel injector for supplying fuel to the engine.”



Limitation of '781 Patent Claim 10	Automotive Electronics Handbook (Jurgen)	German Patent Application Publication No. 29 26 070 (Volkswagen '070)	U.S. Patent No. 4,901,701 (Chasteen)
<p>10. Apparatus for optimizing operation of a vehicle according to claim 7 wherein said processor subsystem further comprises:</p>	<p>See claim 7 claim chart, at page A-39.</p>	<p>See claim 7 claim chart, at page A-39.</p>	<p>E.g., col. 1, lines 9 to 13, "The present invention relates generally to two-stroke operating cycle engines and, more particularly, to a two stroke engine fuel injection system and control system therefor which are adapted for extreme weather conditions."</p> <p>E.g., col. 2, lines 2 to 17, "Small, two-cycle engines are especially subject to malfunction under variable operating conditions such as changes in sea level, with associated barometric changes and changes in ambient air temperature. Many machines such as snowmobiles, snowblowers, dirt bikes, etc., are operated in such widely variable operating conditions. In view of the costs associated with engine modification for sensors' need for electronic control of fuel injectors and in view of the fact that the engine parameters which are critical to control of fuel injectors for two-cycle engines were not, prior to the present invention, understood in the art, a successful electronically-controlled fuel injection system for small, two-cycle engines which are subject to extremes in operating conditions has not been developed in the prior art."</p>
<p>means for determining when road speed for said vehicle is decreasing;</p>	<p>E.g., page 7.6, "There are several applications for rotational speed sensing. First it is necessary to monitor engine speed. This information is used for transmission control, engine control, cruise control, and possibly for a tachometer. Electronics and electronic</p>		

Limitation of '781 Patent Claim 10	Automotive Electronics Handbook (Jurgen)	German Patent Application Publication No. 29 26 070 (Volkswagen '070)	U.S. Patent No. 4,901,701 (Chasteen)
	<p>sensing in the automobile were brought about by the need for higher efficiency engines, better fuel economy, increased power and performance, and lower emissions. Second, <i>wheel speed sensing is required</i> for use in transmissions, cruise control, speedometers, antilock brake systems (ABS), traction control (ASR), variable ratio power steering assist, four-wheel steering, and possibly in inertial navigation and air bag deployment applications.”</p> <p>E.g., page 7.8, “In electronic transmission applications, <i>information from the road and engine speed sensors</i>, as well as torque data and throttle position are required for the MCU to select the optimum gear ratio.”</p>		
<p>means for determining when throttle position for said vehicle is increasing;</p>	<p>E.g., page 12.18, “To control the idle speed, the ECU uses inputs from the <i>throttle position sensor</i>, air conditioning, automatic transmission, power steering, charging system, engine RPM, and vehicle speed.”</p> <p>E.g., page 12.21, “The electronic injection unit also houses the <i>throttle position sensor</i> and, in some cases, an inlet air temperature sensor which provides operating condition information to the ECU.”</p>	<p>E.g., page 6 (English translation), “As can be seen when viewing Figure 1 to begin with, output N of the engine has been plotted across engine speed n. a is the curve of the output at full load, b is a line that represents a constant setting of the output control element, i.e., a line that represents a constant <i>throttle valve angle</i> in a carburetor engine.”</p>	<p>E.g., col. 9, lines 3 to 8, “These sensors may include a battery voltage sensor 134, an air temperature sensor 136, an engine temperature sensor 138, an engine speed sensor 140, an ignition timing sensor 142, a barometric pressure sensor 144, and a <i>throttle position sensor 146</i>.”</p> <p>E.g., FIG. 1</p>
<p>means for determining when manifold pressure for said vehicle is increasing;</p>	<p>E.g., page 2.5, “Automotive specification and testing guidelines have been developed and published by the Society of Automotive Engineers (SAE) specifically for <i>manifold absolute pressure (MAP)</i></p>	<p>E.g., page 6 (English translation), “As can be seen when viewing Figure 1 to begin with, output N of the engine has been plotted across engine speed n. a is the curve of the output at full load, b is a line</p>	

Limitation of '781 Patent Claim 10	Automotive Electronics Handbook (Jurgen)	German Patent Application Publication No. 29 26 070 (Volkswagen '070)	U.S. Patent No. 4,901,701 (Chasteen)
	<p><i>sensors.</i>"</p> <p>E.g., page 2.7, "Manifold absolute pressure (MAP) is used as an input to fuel and ignition control in internal combustion engine control systems. <i>The speed-density system that uses the MAP sensor</i> has been preferred over mass air flow (MAF) control because it's less expensive, but stricter emission standards are causing more manufacturers to use mass air flow for future models."</p>	<p>that represents a constant setting of the output control element, i.e., a line that represents a constant throttle valve angle in a carburetor engine. As a measure thereof, in addition to the throttle valve angle itself, it is also possible to use the <i>induction manifold vacuum.</i>"</p> <p>E.g., page 9 (English translation), "It is useful if in addition to this device, a display of the route-specific fuel consumption is provided in a vehicle. Such display devices are known per se; they generally utilize the <i>injection manifold vacuum</i> as a measure of fuel consumption."</p>	
<p>means for determining when engine speed for said vehicle is decreasing;</p>	<p>E.g., page 7.6, "There are several applications for rotational speed sensing. <i>First it is necessary to monitor engine speed.</i> This information is used for transmission control, engine control, cruise control, and possibly for a tachometer. Electronics and electronic sensing in the automobile were brought about by the need for higher efficiency engines, better fuel economy, increased power and performance, and lower emissions. Second, wheel speed sensing is required for use in transmissions, cruise control, speedometers, antilock brake systems (ABS), traction control (ASR), variable ratio power steering assist, four-wheel steering, and possibly in inertial navigation and air bag deployment applications."</p>	<p>E.g., page 6 (English translation), "The operating ranges I and II are further delimited by <i>engine speed</i> values <math>n_1</math> or <math>n_2</math>, the first of which usually lies between approximately 20 to 50% of the maximum engine speed, and the second usually lies between approximately 40 and 70% of the maximum engine speed."</p> <p>E.g., page 8 (English translation), "<i>The engine speed signal is obtained with the aid of known sensor systems</i>, which therefore need not be described in further detail here."</p>	<p>E.g., col. 9, lines 3 to 8, "These sensors may include a battery voltage sensor 134, an air temperature sensor 136, an engine temperature sensor 138, <i>an engine speed sensor 140</i>, an ignition timing sensor 142, a barometric pressure sensor 144, and a throttle position sensor 146."</p> <p>E.g., FIG. 1</p>

Limitation of '781 Patent Claim 10	Automotive Electronics Handbook (Jurgen)	German Patent Application Publication No. 29 26 070 (Volkswagen '070)	U.S. Patent No. 4,901,701 (Chasteen)
	<p>E.g., page 7.8, "In electronic transmission applications, <i>information from the road and engine speed sensors</i>, as well as torque data and throttle position are required for the MCU to select the optimum gear ratio."</p>		
<p>said processor subsystem activating said downshift notification circuit if both road speed and engine speed are decreasing and both throttle position and manifold pressure for said vehicle are increasing.</p>	<p>E.g., page 13.7 to 13.9, "<b><i>The basic functions of the transmission control are the shift point control</i></b>, the lockup control, engine torque control during shifting, related safety functions, and diagnostic functions for vehicle service."  E.g., page 13.9, "The basic shift point control uses shift maps, which are defined in data in the unit memory. These shift maps are selectable over a wide range. <b><i>The shift point limitations are made</i></b>, on the one hand, by the highest admissible engine speed for each application and, on the other hand, <b><i>by the lowest engine speed that is practical for driving comfort and noise emission. The inputs of the shift point determination are the throttle position, the accelerator pedal position, and the vehicle speed</i></b> (determined by the transmission output speed)."</p>	<p>E.g., pages 6 to 7 (English translation), "Looking initially at operating range I remote from full load, <b><i>the desired output at a lower specific fuel consumption is able to be achieved after upshifting into the next higher gear</i></b>, at an operating point that lies to the left of operating range I in the diagram of Figure 1. <b><i>Accordingly, the device of the present invention generates a signal that asks the operator, i.e., normally the driver, to shift to a higher gear, which is indicated in Figure 1 by the upward pointing arrow within operating range I.</i></b>"  E.g., pages 7 to 8 (English translation), "The two control circuits 2 and 3 are selectively closed by engine-speed dependent change-over switch 6, to which a signal that corresponds to the individual engine speed <math>n</math> is forwarded and which is developed in such a way that <b><i>at engine speeds that are greater than predefined engine speed <math>n_1</math> (see Figure 1), its shift lever pivots upwardly in Figure 2, but at engine speeds that are smaller than predefined engine speed <math>n_2</math>, it pivots in the downward direction from a neutral center position</i></b>, which it therefore assumes when engine speed values between <math>n_1</math> and <math>n_2</math> are present."</p>	<p>E.g., col. 9, lines 1 to 8, "The electronic control assembly comprises a number of sensors having sensor outputs which are provided to the CPU 130 through interface circuitry 132. These sensors may include a battery voltage sensor 134, an air temperature sensor 136, an engine temperature sensor 138, an engine speed sensor 140, an ignition timing sensor 142, a barometric pressure sensor 144, and a throttle position sensor 146."  E.g., col. 9, lines 48 to 55, "The CPU 130 receives and processes the signals from the various sensors described above and generates control signals which are used to control fuel pump speed, to maintain the speed of operation of the fuel pump at a rate which provides a pressure in the circulation conduit portion immediately downstream therefrom which is approximately equal to the preset maximum pressure of the pressure regulator 114."  E.g., col. 11, lines 22 to 33, "As indicated at 303 the CPU determines from the reading taken at 302 whether or not the engine RPM is greater than 0. If engine RPM is greater than 0, the CPU next makes the determination from the throttle</p>



Limitation of '781 Patent Claim 12	Automotive Electronics Handbook (Jurgen)	German Patent Application Publication No. 29 26 070 (Volkswagen '070)	U.S. Patent No. 4,901,701 (Chasteen)
<p>12. Apparatus for optimizing operation of a vehicle according to claim 7 wherein said processor subsystem further comprises:</p>	<p>See claim 7 claim chart, at page A-39.</p>	<p>See claim 7 claim chart, at page A-39.</p>	<p>E.g., col. 1, lines 9 to 13, "The present invention relates generally to two-stroke operating cycle engines and, more particularly, to a two stroke engine fuel injection system and control system therefor which are adapted for extreme weather conditions."</p> <p>E.g., col. 2, lines 2 to 17, "Small, two-cycle engines are especially subject to malfunction under variable operating conditions such as changes in sea level, with associated barometric changes and changes in ambient air temperature. Many machines such as snowmobiles, snowblowers, dirt bikes, etc., are operated in such widely variable operating conditions. In view of the costs associated with engine modification for sensors' need for electronic control of fuel injectors and in view of the fact that the engine parameters which are critical to control of fuel injectors for two-cycle engines were not, prior to the present invention, understood in the art, a successful electronically-controlled fuel injection system for small, two-cycle engines which are subject to extremes in operating conditions has not been developed in the prior art."</p>
<p>means for determining when road speed for said vehicle is decreasing;</p>	<p>E.g., page 7.6, "There are several applications for rotational speed sensing. First it is necessary to monitor engine speed. This information is used for transmission control, engine control, cruise control, and possibly for a</p>		

Limitation of '781 Patent Claim 12	Automotive Electronics Handbook (Jurgen)	German Patent Application Publication No. 29 26 070 (Volkswagen '070)	U.S. Patent No. 4,901,701 (Chasteen)
	<p>tachometer. Electronics and electronic sensing in the automobile were brought about by the need for higher efficiency engines, better fuel economy, increased power and performance, and lower emissions. Second, <i>wheel speed sensing is required</i> for use in transmissions, cruise control, speedometers, antilock brake systems (ABS), traction control (ASR), variable ratio power steering assist, four-wheel steering, and possibly in inertial navigation and air bag deployment applications.”</p> <p>E.g., page 7.8, “In electronic transmission applications, <i>information from the road and engine speed sensors</i>, as well as torque data and throttle position are required for the MCU to select the optimum gear ratio.”</p>		
<p>means for determining when throttle position for said vehicle is increasing;</p>	<p>E.g., page 12.18, “To control the idle speed, the ECU uses inputs from the <i>throttle position sensor</i>, air conditioning, automatic transmission, power steering, charging system, engine RPM, and vehicle speed.”</p> <p>E.g., page 12.21, “The electronic injection unit also houses the <i>throttle position sensor</i> and, in some cases, an inlet air temperature sensor which provides operating condition information to the ECU.”</p>	<p>E.g., page 6 (English translation), “As can be seen when viewing Figure 1 to begin with, output N of the engine has been plotted across engine speed n. a is the curve of the output at full load, b is a line that represents a constant setting of the output control element, i.e., a line that represents a constant <i>throttle valve angle</i> in a carburetor engine.”</p>	<p>E.g., col. 9, lines 3 to 8, “These sensors may include a battery voltage sensor 134, an air temperature sensor 136, an engine temperature sensor 138, an engine speed sensor 140, an ignition timing sensor 142, a barometric pressure sensor 144, and <i>a throttle position sensor 146.</i>”</p> <p>E.g., FIG. 1</p>
<p>means for determining when manifold pressure for said vehicle is increasing;</p>	<p>E.g., page 12.1, “The electronic engine control system consists of <i>sensing devices which continuously measure the</i></p>	<p>E.g., page 6 (English translation), “As can be seen when viewing Figure 1 to begin with, output N of the engine has been</p>	

Limitation of '781 Patent Claim 12	Automotive Electronics Handbook (Jurgen)	German Patent Application Publication No. 29 26 070 (Volkswagen '070)	U.S. Patent No. 4,901,701 (Chasteen)
	<p><i>operating conditions of the engine, an electronic control unit (ECU) which evaluates the sensor inputs</i> using data tables and calculations and determines the output to the actuating devices, and actuating devices which are commanded by the ECU to perform an action in response to the sensor inputs.”</p> <p>E.g., page 22.6, “During the entire operating time of the vehicle, <i>the ECUs are constantly supervising the sensors they are connected to.</i>”</p> <p>E.g., page 13.4, “On the functional side, the hardware configuration can be divided into power supply, input signal transfer circuits, output stages, and <i>microcontroller</i>, including peripheral components and monitoring and safety circuits (Fig. 13.1).”</p>	<p>plotted across engine speed <math>n</math>. <math>a</math> is the curve of the output at full load, <math>b</math> is a line that represents a constant setting of the output control element, i.e., a line that represents a constant <i>throttle valve angle</i> in a carburetor engine. As a measure thereof, in addition to the <i>throttle valve angle</i> itself, it is also possible to use the <i>induction manifold vacuum</i>. . . . The operating ranges I and II are further delimited by <i>engine speed</i> values <math>n_1</math> or <math>n_2</math>, the first of which usually lies between approximately 20 to 50% of the maximum engine speed, and the second usually lies between approximately 40 and 70% of the maximum engine speed.”</p> <p>E.g., page 9 (English translation), “It is useful if in addition to this device, a display of the route-specific fuel consumption is provided in a vehicle. Such display devices are known per se; they generally utilize the <i>injection manifold vacuum</i> as a measure of fuel consumption.”</p>	
<p>means for determining when engine speed for said vehicle is decreasing;</p>	<p>E.g., page 12.4, “During coasting and braking, fuel consumption can be further reduced by shutting off the fuel until the engine speed decreases to slightly higher than the set idle speed. <i>The ECU determines when fuel shutoff can occur by evaluating the throttle position, engine RPM, and vehicle speed.</i>”</p> <p>E.g., page 12.14, “Using the inputs of engine RPM and vehicle speed to the electronic control unit, thresholds can be</p>	<p>E.g., page 6 (English translation), “As can be seen when viewing Figure 1 to begin with, output <math>N</math> of the engine has been plotted across engine speed <math>n</math>. <math>a</math> is the curve of the output at full load, <math>b</math> is a line that represents a constant setting of the output control element, i.e., a line that represents a constant <i>throttle valve angle</i> in a carburetor engine. As a measure thereof, in addition to the <i>throttle valve angle</i> itself, it is also possible to use the <i>induction manifold vacuum</i>. . . . The</p>	<p>E.g., col. 9, lines 3 to 8, “These sensors may include a battery voltage sensor 134, an air temperature sensor 136, an engine temperature sensor 138, <i>an engine speed sensor 140</i>, an ignition timing sensor 142, a barometric pressure sensor 144, and a throttle position sensor 146.”</p> <p>E.g., FIG. 1</p>



Limitation of '781 Patent Claim 12	Automotive Electronics Handbook (Jurgen)	German Patent Application Publication No. 29 26 070 (Volkswagen '070)	U.S. Patent No. 4,901,701 (Chasteen)
	<p>established for limiting these variables with fuel cutoff. <i>When the maximum speed is achieved, the fuel injectors are shut off.</i> When the speed decreases below the threshold, fuel injection resumes.”</p> <p>E.g., page 13.7 to 13.9, “<i>The basic functions of the transmission control are the shift point control</i>, the lockup control, engine torque control during shifting, related safety functions, and diagnostic functions for vehicle service.”</p> <p>E.g., page 13.9, “The basic shift point control uses shift maps, which are defined in data in the unit memory. These shift maps are selectable over a wide range. <i>The shift point limitations are made</i>, on the one hand, by the highest admissible engine speed for each application and, on the other hand, <i>by the lowest engine speed that is practical for driving comfort and noise emission. The inputs of the shift point determination are the throttle position, the accelerator pedal position, and the vehicle speed</i> (determined by the transmission output speed).”</p>	<p>operating ranges I and II are further delimited by <i>engine speed</i> values <math>n_1</math> or <math>n_2</math>, the first of which usually lies between approximately 20 to 50% of the maximum engine speed, and the second usually lies between approximately 40 and 70% of the maximum engine speed.”</p> <p>E.g., page 8 (English translation), “<i>The engine speed signal is obtained with the aid of known sensor systems</i>, which therefore need not be described in further detail here.”</p>	
<p>said processor subsystem activating said fuel overinjection notification circuit if both throttle position and manifold pressure for said vehicle are increasing and road speed and engine speed for said vehicle are decreasing.</p>	<p>E.g., page 13.7 to 13.9, “<i>The basic functions of the transmission control are the shift point control</i>, the lockup control, engine torque control during shifting, related safety functions, and diagnostic functions for vehicle service.”</p> <p>E.g., page 13.9, “The basic shift point control uses shift maps, which are defined</p>	<p>E.g., page 9 (English translation), “It is useful if in addition to this device, <i>a display of the route-specific fuel consumption is provided in a vehicle.</i> Such display devices are known per se; they generally utilize the injection manifold vacuum as a measure of fuel consumption.”</p>	<p>E.g., col. 9, lines 1 to 8, “The electronic control assembly comprises a number of sensors having sensor outputs which are provided to the CPU 130 through interface circuitry 132. These sensors may include a battery voltage sensor 134, an air temperature sensor 136, an engine temperature sensor 138, an engine speed</p>

Limitation of '781 Patent Claim 12	Automotive Electronics Handbook (Jurgen)	German Patent Application Publication No. 29 26 070 (Volkswagen '070)	U.S. Patent No. 4,901,701 (Chasteen)
	<p>in data in the unit memory. These shift maps are selectable over a wide range.</p> <p><i>The shift point limitations are made, on the one hand, by the highest admissible engine speed for each application and, on the other hand, by the lowest engine speed that is practical for driving comfort and noise emission. The inputs of the shift point determination are the throttle position, the accelerator pedal position, and the vehicle speed (determined by the transmission output speed).</i></p>		<p>sensor 140, an ignition timing sensor 142, a barometric pressure sensor 144, and a throttle position sensor 146.”</p> <p>E.g., col. 9, lines 48 to 55, “The CPU 130 receives and processes the signals from the various sensors described above and generates control signals which are used to control fuel pump speed, to maintain the speed of operation of the fuel pump at a rate which provides a pressure in the circulation conduit portion immediately downstream therefrom which is approximately equal to the preset maximum pressure of the pressure regulator 114.”</p> <p>E.g., col. 11, lines 22 to 33, “As indicated at 303 the CPU determines from the reading taken at 302 whether or not the engine RPM is greater than 0. If engine RPM is greater than 0, the CPU next makes the determination from the throttle position reading of 302 whether or not the throttle position is greater than a predetermined amount, such as 20°, as indicated in block 304. If throttle position is less than 20°, the CPU decision-making process returns to block 302. If the throttle position is greater than the predetermined amount and RPM = 0, the CPU provides a control command to the engine fuel injector(s) to prime the engine.”</p> <p>E.g., August 6, 1998 Office Action, “Chasteen discloses the sensors as discussed for sensing the signals and a</p>

Limitation of '781 Patent Claim 12	Automotive Electronics Handbook (Jurgen)	German Patent Application Publication No. 29 26 070 (Volkswagen '070)	U.S. Patent No. 4,901,701 (Chasteen)
			<p>processor and compare manifold pressure for activating the fuel injection. Chasteen discloses the speed (RPM) and throttle position are determined to be greater than 0 (increasing) and the CPU provides a control command to the engine fuel injector to prime the engine (See column 11, lines 22-33) therefore on [sic] would consider increasing and decreasing the speed and throttle for adjusting the fuel injector for supplying fuel to the engine.”</p>

Limitation of '781 Patent Claim 15	Automotive Electronics Handbook (Jurgen)	German Patent Application Publication No. 29 26 070 (Volkswagen '070)	U.S. Patent No. 4,901,701 (Chasteen)
<p>15. Apparatus for optimizing operation of a vehicle according to claim 13 wherein said processor subsystem further comprises:</p>	<p>See claim 13 claim chart, at page A-47.</p>	<p>See claim 13 claim chart, at page A-47.</p>	<p>E.g., col. 1, lines 9 to 13, "The present invention relates generally to two-stroke operating cycle engines and, more particularly, to a two stroke engine fuel injection system and control system therefor which are adapted for extreme weather conditions."</p> <p>E.g., col. 2, lines 2 to 17, "Small, two-cycle engines are especially subject to malfunction under variable operating conditions such as changes in sea level, with associated barometric changes and changes in ambient air temperature. Many machines such as snowmobiles, snowblowers, dirt bikes, etc., are operated in such widely variable operating conditions. In view of the costs associated with engine modification for sensors' need for electronic control of fuel injectors and in view of the fact that the engine parameters which are critical to control of fuel injectors for two-cycle engines were not, prior to the present invention, understood in the art, a successful electronically-controlled fuel injection system for small, two-cycle engines which are subject to extremes in operating conditions has not been developed in the prior art."</p>
<p>means for determining when road speed for said vehicle is increasing or decreasing;</p>	<p>E.g., page 7.6, "There are several applications for rotational speed sensing. First it is necessary to monitor engine speed. This information is used for transmission control, engine control, cruise control, and possibly for a tachometer. Electronics and electronic</p>		

Limitation of '781 Patent Claim 15	Automotive Electronics Handbook (Jurgen)	German Patent Application Publication No. 29 26 070 (Volkswagen '070)	U.S. Patent No. 4,901,701 (Chasteen)
	<p>sensing in the automobile were brought about by the need for higher efficiency engines, better fuel economy, increased power and performance, and lower emissions. Second, <i>wheel speed sensing is required</i> for use in transmissions, cruise control, speedometers, antilock brake systems (ABS), traction control (ASR), variable ratio power steering assist, four-wheel steering, and possibly in inertial navigation and air bag deployment applications.”</p> <p>E.g., page 7.8, “In electronic transmission applications, <i>information from the road and engine speed sensors</i>, as well as torque data and throttle position are required for the MCU to select the optimum gear ratio.”</p>		
<p>means for determining when throttle position for said vehicle is increasing;</p>	<p>E.g., page 12.18, “To control the idle speed, the ECU uses inputs from the <i>throttle position sensor</i>, air conditioning, automatic transmission, power steering, charging system, engine RPM, and vehicle speed.”</p> <p>E.g., page 12.21, “The electronic injection unit also houses the <i>throttle position sensor</i> and, in some cases, an inlet air temperature sensor which provides operating condition information to the ECU.”</p>	<p>E.g., page 6 (English translation), “As can be seen when viewing Figure 1 to begin with, output N of the engine has been plotted across engine speed n. a is the curve of the output at full load, b is a line that represents a constant setting of the output control element, i.e., a line that represents a constant <i>throttle valve angle</i> in a carburetor engine.”</p>	<p>E.g., col. 9, lines 3 to 8, “These sensors may include a battery voltage sensor 134, an air temperature sensor 136, an engine temperature sensor 138, an engine speed sensor 140, an ignition timing sensor 142, a barometric pressure sensor 144, and a <i>throttle position sensor 146</i>.”</p> <p>E.g., FIG. 1</p>
<p>means for comparing manifold pressure to said manifold pressure set point;</p>	<p>E.g., page 12.1, “The electronic engine control system consists of <i>sensing devices which continuously measure the operating conditions of the engine, an electronic control unit (ECU) which</i></p>	<p>E.g., page 9 (English translation), “It is useful if in addition to this device, a display of the route-specific fuel consumption is provided in a vehicle. Such display devices are known per se;</p>	<p>E.g., col. 11, lines 22 to 33, “As indicated at 303 the CPU determines from the reading taken at 302 whether or not the engine RPM is greater than 0. If engine RPM is greater than 0, the CPU next</p>

Limitation of '781 Patent Claim 15	Automotive Electronics Handbook (Jurgen)	German Patent Application Publication No. 29 26 070 (Volkswagen '070)	U.S. Patent No. 4,901,701 (Chasteen)
	<p><i>evaluates the sensor inputs</i> using data tables and calculations and determines the output to the actuating devices, and actuating devices which are commanded by the ECU to perform an action in response to the sensor inputs.”</p> <p>E.g., page 22.6, “During the entire operating time of the vehicle, <i>the ECUs are constantly supervising the sensors they are connected to.</i>”</p> <p>E.g., page 13.4, “On the functional side, the hardware configuration can be divided into power supply, input signal transfer circuits, output stages, and <i>microcontroller</i>, including peripheral components and monitoring and safety circuits (Fig. 13.1).”</p>	<p>they generally utilize the <i>injection manifold vacuum</i> as a measure of fuel consumption.”</p>	<p>makes the determination from the throttle position reading of 302 whether or not the throttle position is greater than a predetermined amount, such as 20°, as indicated in block 304. If throttle position is less than 20°, the CPU decision-making process returns to block 302. If the throttle position is greater than the predetermined amount and RPM = 0, the CPU provides a control command to the engine fuel injector(s) to prime the engine.”</p>
<p>means for comparing engine speed to said RPM set point;</p>	<p>E.g., page 13.7 to 13.9, “<i>The basic functions of the transmission control are the shift point control</i>, the lockup control, engine torque control during shifting, related safety functions, and diagnostic functions for vehicle service.”</p> <p>E.g., page 13.9, “The basic shift point control uses shift maps, which are defined in data in the unit memory. These shift maps are selectable over a wide range. <i>The shift point limitations are made</i>, on the one hand, by the highest admissible engine speed for each application and, on the other hand, <i>by the lowest engine speed that is practical for driving comfort and noise emission. The inputs of the shift point determination are the</i></p>	<p>E.g., pages 6 to 7 (English translation), “Looking initially at operating range I remote from full load, <i>the desired output at a lower specific fuel consumption is able to be achieved after upshifting into the next higher gear</i>, at an operating point that lies to the left of operating range I in the diagram of Figure 1. <i>Accordingly, the device of the present invention generates a signal that asks the operator, i.e., normally the driver, to shift to a higher gear, which is indicated in Figure 1 by the upward pointing arrow within operating range I.</i>”</p> <p>E.g., pages 7 to 8 (English translation), “The two control circuits 2 and 3 are selectively closed by engine-speed</p>	<p>E.g., col. 11, lines 22 to 33, “<i>As indicated at 303 the CPU determines from the reading taken at 302 whether or not the engine RPM is greater than 0.</i> If engine RPM is greater than 0, the CPU next makes the determination from the throttle position reading of 302 whether or not the throttle position is greater than a predetermined amount, such as 20°, as indicated in block 304. If throttle position is less than 20°, the CPU decision-making process returns to block 302. <i>If the throttle position is greater than the predetermined amount and RPM = 0, the CPU provides a control command to the engine fuel injector(s) to prime the engine.</i>”</p>

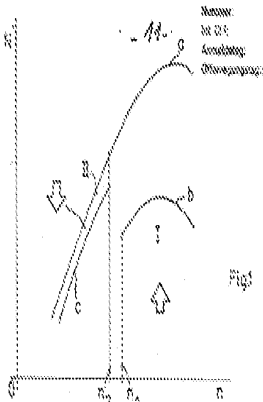
Limitation of '781 Patent Claim 15	Automotive Electronics Handbook (Jurgen)	German Patent Application Publication No. 29 26 070 (Volkswagen '070)	U.S. Patent No. 4,901,701 (Chasteen)
	<p><i>throttle position, the accelerator pedal position, and the vehicle speed (determined by the transmission output speed)."</i></p>	<p>dependent change-over switch 6, to which a signal that corresponds to the individual engine speed <math>n</math> is forwarded and which is developed in such a way that <i>at engine speeds that are greater than predefined engine speed <math>n_1</math> (see Figure 1), its shift lever pivots upwardly in Figure 2, but at engine speeds that are smaller than predefined engine speed <math>n_2</math>, it pivots in the downward direction from a neutral center position, which it therefore assumes when engine speed values between <math>n_1</math> and <math>n_2</math> are present."</i></p> <p>E.g., Figure 1:</p>  <p>E.g., Figure 2:</p>	

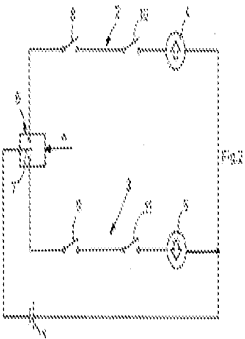
Limitation of '781 Patent Claim 15	Automotive Electronics Handbook (Jurgen)	German Patent Application Publication No. 29 26 070 (Volkswagen '070)	U.S. Patent No. 4,901,701 (Chasteen)
			
<p>means for determining when manifold pressure is increasing;</p>	<p>E.g., page 12.1, “The electronic engine control system consists of <i>sensing devices which continuously measure the operating conditions of the engine, an electronic control unit (ECU) which evaluates the sensor inputs</i> using data tables and calculations and determines the output to the actuating devices, and actuating devices which are commanded by the ECU to perform an action in response to the sensor inputs.”</p> <p>E.g., page 22.6, “During the entire operating time of the vehicle, <i>the ECUs are constantly supervising the sensors they are connected to.</i>”</p> <p>E.g., page 13.4, “On the functional side, the hardware configuration can be divided into power supply, input signal transfer circuits, output stages, and <i>microcontroller</i>, including peripheral components and monitoring and safety circuits (Fig. 13.1).”</p>	<p>E.g., page 9 (English translation), “It is useful if in addition to this device, a display of the route-specific fuel consumption is provided in a vehicle. Such display devices are known per se; they generally utilize the <i>injection manifold vacuum</i> as a measure of fuel consumption.”</p>	
<p>means for determining when engine speed is increasing or decreasing;</p>	<p>E.g., page 12.4, “During coasting and braking, fuel consumption can be further</p>	<p>E.g., page 6 (English translation), “As can be seen when viewing Figure 1 to begin</p>	<p>E.g., col. 9, lines 3 to 8, “These sensors may include a battery voltage sensor 134,</p>



Limitation of '781 Patent Claim 15	Automotive Electronics Handbook (Jurgen)	German Patent Application Publication No. 29 26 070 (Volkswagen '070)	U.S. Patent No. 4,901,701 (Chasteen)
	<p>reduced by shutting off the fuel until the engine speed decreases to slightly higher than the set idle speed. <i>The ECU determines when fuel shutoff can occur by evaluating the throttle position, engine RPM, and vehicle speed.</i>"</p> <p>E.g., page 12.14, "Using the inputs of engine RPM and vehicle speed to the electronic control unit, thresholds can be established for limiting these variables with fuel cutoff. <i>When the maximum speed is achieved, the fuel injectors are shut off.</i> When the speed decreases below the threshold, fuel injection resumes."</p> <p>E.g., page 13.7 to 13.9, "<i>The basic functions of the transmission control are the shift point control</i>, the lockup control, engine torque control during shifting, related safety functions, and diagnostic functions for vehicle service."</p> <p>E.g., page 13.9, "The basic shift point control uses shift maps, which are defined in data in the unit memory. These shift maps are selectable over a wide range. <i>The shift point limitations are made</i>, on the one hand, by the highest admissible engine speed for each application and, on the other hand, <i>by the lowest engine speed that is practical for driving comfort and noise emission. The inputs of the shift point determination are the throttle position, the accelerator pedal position, and the vehicle speed</i> (determined by the transmission output speed)."</p>	<p>with, output N of the engine has been plotted across engine speed n. a is the curve of the output at full load, b is a line that represents a constant setting of the output control element, i.e., a line that represents a constant <i>throttle valve angle</i> in a carburetor engine. As a measure thereof, in addition to the <i>throttle valve angle</i> itself, it is also possible to use the <i>induction manifold vacuum</i>. . . . The operating ranges I and II are further delimited by <i>engine speed</i> values <math>n_1</math> or <math>n_2</math>, the first of which usually lies between approximately 20 to 50% of the maximum engine speed, and the second usually lies between approximately 40 and 70% of the maximum engine speed."</p> <p>E.g., page 8 (English translation), "<i>The engine speed signal is obtained with the aid of known sensor systems</i>, which therefore need not be described in further detail here."</p>	<p>an air temperature sensor 136, an engine temperature sensor 138, <i>an engine speed sensor 140</i>, an ignition timing sensor 142, a barometric pressure sensor 144, and a throttle position sensor 146."</p> <p>E.g., FIG. 1</p>

Limitation of '781 Patent Claim 15	Automotive Electronics Handbook (Jurgen)	German Patent Application Publication No. 29 26 070 (Volkswagen '070)	U.S. Patent No. 4,901,701 (Chasteen)
<p>said processor subsystem activating said upshift notification circuit if both road speed and throttle position for said vehicle are increasing, manifold pressure for said vehicle is at or below said manifold pressure set point and engine speed for said vehicle is at or above said RPM set point; and</p>	<p>E.g., page 13.7 to 13.9, "<i>The basic functions of the transmission control are the shift point control, the lockup control, engine torque control during shifting, related safety functions, and diagnostic functions for vehicle service.</i>"</p> <p>E.g., page 13.9, "The basic shift point control uses shift maps, which are defined in data in the unit memory. These shift maps are selectable over a wide range. <i>The shift point limitations are made, on the one hand, by the highest admissible engine speed for each application and, on the other hand, by the lowest engine speed that is practical for driving comfort and noise emission. The inputs of the shift point determination are the throttle position, the accelerator pedal position, and the vehicle speed (determined by the transmission output speed).</i>"</p>	<p>E.g., pages 6 to 7 (English translation), "Looking initially at operating range I remote from full load, <i>the desired output at a lower specific fuel consumption is able to be achieved after upshifting into the next higher gear</i>, at an operating point that lies to the left of operating range I in the diagram of Figure 1. <i>Accordingly, the device of the present invention generates a signal that asks the operator, i.e., normally the driver, to shift to a higher gear, which is indicated in Figure 1 by the upward pointing arrow within operating range I.</i>"</p> <p>E.g., pages 7 to 8 (English translation), "The two control circuits 2 and 3 are selectively closed by engine-speed dependent change-over switch 6, to which a signal that corresponds to the individual engine speed <math>n</math> is forwarded and which is developed in such a way that <i>at engine speeds that are greater than predefined engine speed <math>n_1</math> (see Figure 1), its shift lever pivots upwardly in Figure 2, but at engine speeds that are smaller than predefined engine speed <math>n_2</math>, it pivots in the downward direction from a neutral center position</i>, which it therefore assumes when engine speed values between <math>n_1</math> and <math>n_2</math> are present."</p> <p>E.g., Figure 1:</p>	<p>E.g., col. 11, lines 22 to 33, "As indicated at 303 the CPU determines from the reading taken at 302 whether or not the engine RPM is greater than 0. If engine RPM is greater than 0, the CPU next makes the determination from the throttle position reading of 302 whether or not the throttle position is greater than a predetermined amount, such as 20°, as indicated in block 304. If throttle position is less than 20°, the CPU decision-making process returns to block 302. If the throttle position is greater than the predetermined amount and RPM = 0, the CPU provides a control command to the engine fuel injector(s) to prime the engine."</p> <p>E.g., August 6, 1998 Office Action, "Chasteen discloses the sensors as discussed for sensing the signals and a processor and compare manifold pressure for activating the fuel injection. Chasteen discloses the speed (RPM) and throttle position are determined to be greater than 0 (increasing) and the CPU provides a control command to the engine fuel injector to prime the engine (See column 11, lines 22-33) therefore on [sic] would consider increasing and decreasing the speed and throttle for adjusting the fuel injector for supplying fuel to the engine."</p>

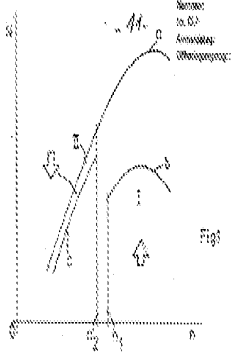
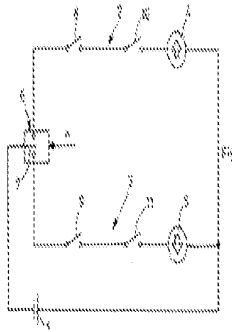
Limitation of '781 Patent Claim 15	Automotive Electronics Handbook (Jurgen)	German Patent Application Publication No. 29 26 070 (Volkswagen '070)	U.S. Patent No. 4,901,701 (Chasteen)
		 <p>E.g., Figure 2:</p> 	
<p>said processor subsystem activating said downshift notification circuit if both road speed and engine speed are decreasing and both throttle position and manifold pressure for said vehicle are increasing.</p>	<p>E.g., page 13.7 to 13.9, “<i>The basic functions of the transmission control are the shift point control, the lockup control, engine torque control during shifting, related safety functions, and diagnostic functions for vehicle service.</i>” E.g., page 13.9, “The basic shift point control uses shift maps, which are defined in data in the unit memory. These shift maps are selectable over a wide range. <i>The shift point limitations are made, on the one hand, by the highest admissible engine speed for each application and, on the other hand, by the lowest engine speed that is practical for driving</i></p>	<p>E.g., pages 6 to 7 (English translation), “Looking initially at operating range I remote from full load, <i>the desired output at a lower specific fuel consumption is able to be achieved after upshifting into the next higher gear</i>, at an operating point that lies to the left of operating range I in the diagram of Figure 1. <i>Accordingly, the device of the present invention generates a signal that asks the operator, i.e., normally the driver, to shift to a higher gear, which is indicated in Figure 1 by the upward pointing arrow within operating range I.</i>”</p>	<p>E.g., col. 11, lines 22 to 33, “As indicated at 303 the CPU determines from the reading taken at 302 whether or not the engine RPM is greater than 0. If engine RPM is greater than 0, the CPU next makes the determination from the throttle position reading of 302 whether or not the throttle position is greater than a predetermined amount, such as 20°, as indicated in block 304. If throttle position is less than 20°, the CPU decision-making process returns to block 302. If the throttle position is greater than the predetermined amount and RPM = 0, the CPU provides a control command to the</p>

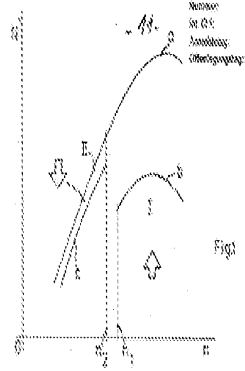
Limitation of '781 Patent Claim 15	Automotive Electronics Handbook (Jurgen)	German Patent Application Publication No. 29 26 070 (Volkswagen '070)	U.S. Patent No. 4,901,701 (Chasteen)
	<p><i>comfort and noise emission. The inputs of the shift point determination are the throttle position, the accelerator pedal position, and the vehicle speed (determined by the transmission output speed)."</i></p>	<p>E.g., pages 7 to 8 (English translation), "The two control circuits 2 and 3 are selectively closed by engine-speed dependent change-over switch 6, to which a signal that corresponds to the individual engine speed <math>n</math> is forwarded and which is developed in such a way that <i>at engine speeds that are greater than predefined engine speed <math>n_1</math> (see Figure 1), its shift lever pivots upwardly in Figure 2, but at engine speeds that are smaller than predefined engine speed <math>n_2</math>, it pivots in the downward direction from a neutral center position</i>, which it therefore assumes when engine speed values between <math>n_1</math> and <math>n_2</math> are present."</p> <p>E.g., Figure 1:</p>  <p>E.g., Figure 2:</p>	<p>engine fuel injector(s) to prime the engine."</p> <p>E.g., August 6, 1998 Office Action, "Chasteen discloses the sensors as discussed for sensing the signals and a processor and compare manifold pressure for activating the fuel injection. Chasteen discloses the speed (RPM) and throttle position are determined to be greater than 0 (increasing) and the CPU provides a control command to the engine fuel injector to prime the engine (See column 11, lines 22-33) therefore on [sic] would consider increasing and decreasing the speed and throttle for adjusting the fuel injector for supplying fuel to the engine."</p>

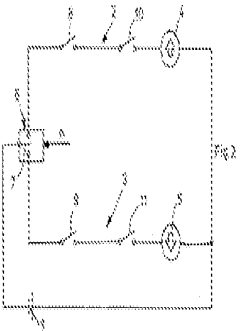
Limitation of '781 Patent Claim 15	Automotive Electronics Handbook (Jurgen)	German Patent Application Publication No. 29 26 070 (Volkswagen '070)	U.S. Patent No. 4,901,701 (Chasteen)
		 <p>The diagram, labeled 'Fig. 2', shows a rectangular circuit loop. On the left vertical wire, there is a power source symbol (a battery) with terminals labeled '1' and '2'. The top horizontal wire contains a switch labeled '3' and a lamp labeled '4'. The bottom horizontal wire contains a switch labeled '5' and a lamp labeled '6'. The right vertical wire is a simple connecting line. The entire circuit is enclosed in a dashed rectangular border.</p>	

15. Claim 18 is Obvious in View of the Combination of Jurgen, Toyota '599, Davidian, and Tonkin

Limitation of '781 Patent Claim 18	Automotive Electronics Handbook (Jurgen)	U.S. Patent No. 4,559,599 (Toyota '599)	U.S. Patent No. 5,357,438 (Davidian)	PCT Publication No. WO 96/02853 (Tonkin)
18. Apparatus for optimizing operation of a vehicle according to claim 17 wherein:	See claim 17 claim chart, at page A-57.	See claim 17 claim chart, at page A-57.	See claim 17 claim chart, at page A-57.	E.g., Abstract, "The system comprising a controller fitted to a subject vehicle (16) and sensor means (20) operable to sense a distance of separation and relative velocity of a trailing vehicle (18). Also input to the controller is a velocity signal derived from a velocity sensing means (97) determining the ground speed of the subject vehicle using a doppler radar system. The controller calculates a safety envelope and activates a visible warning device attached to the rear of the subject vehicle if the trailing vehicle penetrates the safety envelope. An enhanced safety envelope determined by adverse road conditions is also established, any incursion into the enhanced envelope resulting generally in the visible warning being at a less prominent level. If however the closing speed of the trailing vehicle exceeds a predetermined threshold, penetration of the enhanced envelope results immediately in the full warning being displayed with full prominence to the driver of the trailing vehicle. The system has application to improving the safety of road vehicles."

Limitation of '781 Patent Claim 18	Automotive Electronics Handbook (Jurgen)	U.S. Patent No. 4,559,599 (Toyota '599)	U.S. Patent No. 5,357,438 (Davidian)	PCT Publication No. WO 96/02853 (Tonkin)
<p>said at least one sensor further includes a windshield wiper sensor for indicating whether a windshield wiper of said vehicle is activated; and</p>			<p>E.g., col. 4, line 67 to col. 5, line 2, "The automatic sensors on vehicle 2 further include a daylight sensor 14, <i>a rain sensor 16</i>, a vehicle load sensor 18, a trailer-hitch sensor 20, and a reverse gear sensor 22."</p> <p>E.g., col. 8, lines 58 to 63, "Thus, module 90 receives inputs from the front space sensor 8, the rear space sensor 10, and the vehicle speed sensor 12. <i>Module 90 also receives inputs from the sensors in case there is no depressible key, e.g., the daylight sensor 14, the trailer sensor 20, the reverse gear sensor 22, the rain sensor 16, and the vehicle load sensor 18.</i>"</p>	<p>E.g., page 18, lines 9 to 13, "The information regarding the weather might be obtained for example by enabling the warning system controller to ascertain if the windscreen wipers are in use or have been in use recently due to rain (and not used with a water spray to clean the windscreen)."</p>
<p>said memory subsystem further storing a second vehicle speed/stopping distance table.</p>			<p>E.g., col. 9, lines 20 to 27, "<i>Computer module 90 also includes information about the vehicle braking distances as a function of speed. This is preferably in the form of a look-up table</i>, for example, provided by the manufacturer for predetermined defined conditions concerning road type, skidding danger, vehicle load and tires pressure, and is <i>stored in a ROM (read-only memory) of the microcomputer so that it can be changed periodically if necessary.</i>"</p>	<p>E.g., page 18, lines 16 to 19, "Thus, safe stopping distances can be adjusted for prevailing weather conditions, again by providing stored values according to weather and possibly for different severities of poor weather."</p> <p>E.g., page 3, lines 25 to 32, "The size of the enhanced safe distance and enlarged safety envelope will generally be predetermined so as to correspond to typical parameters appropriate for driving under adverse road conditions. <i>These</i></p>

Limitation of '781 Patent Claim 18	Automotive Electronics Handbook (Jurgen)	U.S. Patent No. 4,559,599 (Toyota '599)	U.S. Patent No. 5,357,438 (Davidian)	PCT Publication No. WO 96/02853 (Tonkin)
			<p>E.g., col. 12, line 59 to col 13, line 22, "The system then makes the computations illustrated (as an example) in block 162 to determine the stopping distance SD, which is equal to the reaction distance plus the braking distance multiplied by a stopping factor ST and a safety factor SF. <i>In the illustrated example, the stopping distance is the sum of the reaction distance and the braking distance.</i> The reaction distance is the product of the reaction time, visibility condition, daylight condition, reaction factor and speed; and <i>the braking distance is the product of the braking distance (as supplied by the manufacturer), road type, skidding danger, vehicle load and braking factor.</i> The stopping distance (SD) includes further safety factors, and determines when the safety alarm will be actuated to first alert the driver of an approaching collision danger.</p> <p>A determination is also made of the collision distance CD which is equal to the stopping distance SD divided by the collision safety factor CSF, e.g., 1.25 in the example illustrated above, such that should the distance between the vehicle and the</p>	<p><i>parameters may for example be stored in a look up table</i> allowing the parameters to be determined from the signals received by the controller together with the parameters defining the normal safety envelope."</p> <p>E.g., page 16, lines 2 to 21, "The control system is designed to activate display 12 to provide a warning signal to a driver of the trailing vehicle when the trailing vehicle 18 when the trailing vehicle is closing too rapidly on the subject vehicle 16 for example, alternately a warning signal is displayed when the trailing vehicle 18 is too close to the subject vehicle 16. Even if they are travelling at the same speed for example, <u>there are known safe stopping distances such as those published by the Minister of Transport</u>, in which a vehicle will stop when the brakes are applied. Accordingly, by knowing the velocity of the subject vehicle 16 for example preferably using the radar ground sensing system described herein, which provides therefore a true ground speed, or other means in communication with a microprocessor control system and by using a proximity sensor 20 to determine the separation of</p>



Limitation of '781 Patent Claim 18	Automotive Electronics Handbook (Jurgen)	U.S. Patent No. 4,559,599 (Toyota '599)	U.S. Patent No. 5,357,438 (Davidian)	PCT Publication No. WO 96/02853 (Tonkin)
			<p>object come within the collision distance CD, the collision alarm is then actuated.</p> <p>The foregoing calculations of stopping distance SD and collision distance CD with respect to objects at the front of the vehicle are also made with respect to objects at the rear of the vehicle, these calculations being RSD and RCD, respectively, also shown in block 162.</p> <p>Whenever the distance between the vehicle and an object to the front of the vehicle or to the rear of the vehicle comes within the stopping distance SD and the collision distance CD, the system operates according to the deceleration alarm module 93, as indicated by block 164.”</p>	<p>the subject vehicle 16 from the trailing vehicle 18 a safety envelope can be created behind the subject vehicle 16. Intrusion in the envelope by the trailing vehicle 18 causes an initial level of lamps 13 in array 12 to be lit.”</p> <p>E.g., page 17, lines 7 to 25, “Thus a warning system has been described using a ground speed sensor for a subject vehicle 16 coupled by a microprocessor with a proximity sensor 20. In a more sophisticated [sic] version, proximity sensor 20 could be a radar device described herein for measuring velocity and could therefore be used to measure the relative velocity of a subject vehicle 16 and trailing vehicle 18. By knowing the closing speed of the trailing vehicle 18 predetermined values could be used to trigger warning displays if the closing speed is too great. <i>For example, a look-up table or database could again be provided for unsafe closing speeds. This look-up table might again be varied according to the velocity of the subject vehicle 16 in a similar manner to the safe stopping distance, or safety envelope distance.</i> Therefore, whilst the safety envelope distance at 30mph is 25 metres,</p>

Limitation of '781 Patent Claim 18	Automotive Electronics Handbook (Jurgen)	U.S. Patent No. 4,559,599 (Toyota '599)	U.S. Patent No. 5,357,438 (Davidian)	PCT Publication No. WO 96/02853 (Tonkin)
				<p>if the trailing vehicle is closing too rapidly, say, a difference in speed of 30mph, then the warning signal could be activated even when the trailing vehicle 18 is 50 metres behind the subject vehicle 16.”</p>

16. Claim 18 is Obvious in View of the Combination of Jurgen, Volkswagen '070, Davidian, and Tonkin

Limitation of '781 Patent Claim 18	Automotive Electronics Handbook (Jurgen)	German Patent Application Publication No. 29 26 070 (Volkswagen '070)	U.S. Patent No. 5,357,438 (Davidian)	PCT Publication No. WO 96/02853 (Tonkin)
18. Apparatus for optimizing operation of a vehicle according to claim 17 wherein:	See claim 17 claim chart, at page A-104.	See claim 17 claim chart, at page A-104.	See claim 17 claim chart, at page A-104.	E.g., Abstract, "The system comprising a controller fitted to a subject vehicle (16) and sensor means (20) operable to sense a distance of separation and relative velocity of a trailing vehicle (18). Also input to the controller is a velocity signal derived from a velocity sensing means (97) determining the ground speed of the subject vehicle using a doppler radar system. The controller calculates a safety envelope and activates a visible warning device attached to the rear of the subject vehicle if the trailing vehicle penetrates the safety envelope. An enhanced safety envelope determined by adverse road conditions is also established, any incursion into the enhanced envelope resulting generally in the visible warning being at a less prominent level. If however the closing speed of the trailing vehicle exceeds a predetermined threshold, penetration of the enhanced envelope results immediately in the full warning being displayed with full prominence to the driver of the trailing vehicle. The system has application to improving the safety of road vehicles."

Limitation of '781 Patent Claim 18	Automotive Electronics Handbook (Jurgen)	German Patent Application Publication No. 29 26 070 (Volkswagen '070)	U.S. Patent No. 5,357,438 (Davidian)	PCT Publication No. WO 96/02853 (Tonkin)
<p>said at least one sensor further includes a windshield wiper sensor for indicating whether a windshield wiper of said vehicle is activated; and</p>			<p>E.g., col. 4, line 67 to col. 5, line 2, "The automatic sensors on vehicle 2 further include a daylight sensor 14, <i>a rain sensor 16</i>, a vehicle load sensor 18, a trailer-hitch sensor 20, and a reverse gear sensor 22."</p> <p>E.g., col. 8, lines 58 to 63, "Thus, module 90 receives inputs from the front space sensor 8, the rear space sensor 10, and the vehicle speed sensor 12. <i>Module 90 also receives inputs from the sensors in case there is no depressible key, e.g., the daylight sensor 14, the trailer sensor 20, the reverse gear sensor 22, the rain sensor 16, and the vehicle load sensor 18.</i>"</p>	<p>E.g., page 18, lines 9 to 13, "The information regarding the weather might be obtained for example by enabling the warning system controller to ascertain if the windscreen wipers are in use or have been in use recently due to rain (and not used with a water spray to clean the windscreen)."</p>
<p>said memory subsystem further storing a second vehicle speed/stopping distance table.</p>			<p>E.g., col. 9, lines 20 to 27, "<i>Computer module 90 also includes information about the vehicle braking distances as a function of speed. This is preferably in the form of a look-up table</i>, for example, provided by the manufacturer for predetermined defined conditions concerning road type, skidding danger, vehicle load and tires pressure, and is <i>stored in a ROM (read-only memory) of the microcomputer so that it can be changed periodically if necessary.</i>"</p>	<p>E.g., page 18, lines 16 to 19, "Thus, safe stopping distances can be adjusted for prevailing weather conditions, again by providing stored values according to weather and possibly for different severities of poor weather."</p> <p>E.g., page 3, lines 25 to 32, "The size of the enhanced safe distance and enlarged safety envelope will generally be predetermined so as to correspond to typical parameters appropriate for driving under</p>

Limitation of '781 Patent Claim 18	Automotive Electronics Handbook (Jurgen)	German Patent Application Publication No. 29 26 070 (Volkswagen '070)	U.S. Patent No. 5,357,438 (Davidian)	PCT Publication No. WO 96/02853 (Tonkin)
			<p>E.g., col. 12, line 59 to col 13, line 22, "The system then makes the computations illustrated (as an example) in block 162 to determine the stopping distance SD, which is equal to the reaction distance plus the braking distance multiplied by a stopping factor ST and a safety factor SF. <i>In the illustrated example, the stopping distance is the sum of the reaction distance and the braking distance.</i> The reaction distance is the product of the reaction time, visibility condition, daylight condition, reaction factor and speed; and <i>the braking distance is the product of the braking distance (as supplied by the manufacturer), road type, skidding danger, vehicle load and braking factor.</i> The stopping distance (SD) includes further safety factors, and determines when the safety alarm will be actuated to first alert the driver of an approaching collision danger.</p> <p>A determination is also made of the collision distance CD which is equal to the stopping distance SD divided by the collision safety factor CSF, e.g., 1.25 in the example illustrated above,</p>	<p>adverse road conditions. <i>These parameters may for example be stored in a look up table</i> allowing the parameters to be determined from the signals received by the controller together with the parameters defining the normal safety envelope."</p> <p>E.g., page 16, lines 2 to 21, "The control system is designed to activate display 12 to provide a warning signal to a driver of the trailing vehicle when the trailing vehicle 18 when the trailing vehicle is closing too rapidly on the subject vehicle 16 for example, alternately a warning signal is displayed when the trailing vehicle 18 is too close to the subject vehicle 16. Even if they are travelling at the same speed for example, <u>there are known safe stopping distances such as those published by the Minister of Transport</u>, in which a vehicle will stop when the brakes are applied. Accordingly, by knowing the velocity of the subject vehicle 16 for example preferably using the radar ground sensing system described herein, which provides therefore a true ground speed, or other means in communication with a microprocessor control system</p>

Limitation of '781 Patent Claim 18	Automotive Electronics Handbook (Jurgen)	German Patent Application Publication No. 29 26 070 (Volkswagen '070)	U.S. Patent No. 5,357,438 (Davidian)	PCT Publication No. WO 96/02853 (Tonkin)
			<p>such that should the distance between the vehicle and the object come within the collision distance CD, the collision alarm is then actuated.</p> <p>The foregoing calculations of stopping distance SD and collision distance CD with respect to objects at the front of the vehicle are also made with respect to objects at the rear of the vehicle, these calculations being RSD and RCD, respectively, also shown in block 162.</p> <p>Whenever the distance between the vehicle and an object to the front of the vehicle or to the rear of the vehicle comes within the stopping distance SD and the collision distance CD, the system operates according to the deceleration alarm module 93, as indicated by block 164."</p>	<p>and by using a proximity sensor 20 to determine the separation of the subject vehicle 16 from the trailing vehicle 18 a safety envelope can be created behind the subject vehicle 16. Intrusion in the envelope by the trailing vehicle 18 causes an initial level of lamps 13 in array 12 to be lit."</p> <p>E.g., page 17, lines 7 to 25, "Thus a warning system has been described using a ground speed sensor for a subject vehicle 16 coupled by a microprocessor with a proximity sensor 20. In a more sophisticated [sic] version, proximity sensor 20 could be a radar device described herein for measuring velocity and could therefore be used to measure the relative velocity of a subject vehicle 16 and trailing vehicle 18. By knowing the closing speed of the trailing vehicle 18 predetermined values could be used to trigger warning displays if the closing speed is too great. <i>For example, a look-up table or database could again be provided for unsafe closing speeds. This look-up table might again be varied according to the velocity of the subject vehicle 16 in a similar manner to the safe stopping distance, or safety</i></p>

Limitation of '781 Patent Claim 18	Automotive Electronics Handbook (Jurgen)	German Patent Application Publication No. 29 26 070 (Volkswagen '070)	U.S. Patent No. 5,357,438 (Davidian)	PCT Publication No. WO 96/02853 (Tonkin)
				<p><i>envelope distance.</i> Therefore, whilst the safety envelope distance at 30mph is 25 metres, if the trailing vehicle is closing too rapidly, say, a difference in speed of 30mph, then the warning signal could be activated even when the trailing vehicle 18 is 50 metres behind the subject vehicle 16.”</p>

17. Claim 18 is Obvious in View of the Combination of Jurgen, Saturn '452, Davidian, and Tonkin

Limitation of '781 Patent Claim 18	Automotive Electronics Handbook (Jurgen)	U.S. Patent No. 5,477,452 (Saturn '452)	U.S. Patent No. 5,357,438 (Davidian)	PCT Publication No. WO 96/02853 (Tonkin)
18. Apparatus for optimizing operation of a vehicle according to claim 17 wherein:	See claim 17 claim chart, at page A-153.	See claim 17 claim chart, at page A-153.	See claim 17 claim chart, at page A-153.	E.g., Abstract, "The system comprising a controller fitted to a subject vehicle (16) and sensor means (20) operable to sense a distance of separation and relative velocity of a trailing vehicle (18). Also input to the controller is a velocity signal derived from a velocity sensing means (97) determining the ground speed of the subject vehicle using a doppler radar system. The controller calculates a safety envelope and activates a visible warning device attached to the rear of the subject vehicle if the trailing vehicle penetrates the safety envelope. An enhanced safety envelope determined by adverse road conditions is also established, any incursion into the enhanced envelope resulting generally in the visible warning being at a less prominent level. If however the closing speed of the trailing vehicle exceeds a predetermined threshold, penetration of the enhanced envelope results immediately in the full warning being displayed with full prominence to the driver of the trailing vehicle. The system has application to improving the safety of road vehicles."



Limitation of '781 Patent Claim 18	Automotive Electronics Handbook (Jurgen)	U.S. Patent No. 5,477,452 (Saturn '452)	U.S. Patent No. 5,357,438 (Davidian)	PCT Publication No. WO 96/02853 (Tonkin)
<p>said at least one sensor further includes a windshield wiper sensor for indicating whether a windshield wiper of said vehicle is activated; and</p>			<p>E.g., col. 4, line 67 to col. 5, line 2, "The automatic sensors on vehicle 2 further include a daylight sensor 14, <i>a rain sensor 16</i>, a vehicle load sensor 18, a trailer-hitch sensor 20, and a reverse gear sensor 22."</p> <p>E.g., col. 8, lines 58 to 63, "Thus, module 90 receives inputs from the front space sensor 8, the rear space sensor 10, and the vehicle speed sensor 12. <i>Module 90 also receives inputs from the sensors in case there is no depressible key, e.g., the daylight sensor 14, the trailer sensor 20, the reverse gear sensor 22, the rain sensor 16, and the vehicle load sensor 18.</i>"</p>	<p>E.g., page 18, lines 9 to 13, "The information regarding the weather might be obtained for example by enabling the warning system controller to ascertain if the windscreen wipers are in use or have been in use recently due to rain (and not used with a water spray to clean the windscreen)."</p>
<p>said memory subsystem further storing a second vehicle speed/stopping distance table.</p>			<p>E.g., col. 9, lines 20 to 27, "<i>Computer module 90 also includes information about the vehicle braking distances as a function of speed. This is preferably in the form of a look-up table</i>, for example, provided by the manufacturer for predetermined defined conditions concerning road type, skidding danger, vehicle load and tires pressure, and is <i>stored in a ROM (read-only memory) of the microcomputer so that it can be changed periodically if necessary.</i>"</p>	<p>E.g., page 18, lines 16 to 19, "Thus, safe stopping distances can be adjusted for prevailing weather conditions, again by providing stored values according to weather and possibly for different severities of poor weather." E.g., page 3, lines 25 to 32, "The size of the enhanced safe distance and enlarged safety envelope will generally be predetermined so as to correspond to typical parameters appropriate for driving under adverse road conditions. <i>These parameters may for example be</i></p>

Limitation of '781 Patent Claim 18	Automotive Electronics Handbook (Jurgen)	U.S. Patent No. 5,477,452 (Saturn '452)	U.S. Patent No. 5,357,438 (Davidian)	PCT Publication No. WO 96/02853 (Tonkin)
			<p>E.g., col. 12, line 59 to col 13, line 22, "The system then makes the computations illustrated (as an example) in block 162 to determine the stopping distance SD, which is equal to the reaction distance plus the braking distance multiplied by a stopping factor ST and a safety factor SF. <i>In the illustrated example, the stopping distance is the sum of the reaction distance and the braking distance.</i> The reaction distance is the product of the reaction time, visibility condition, daylight condition, reaction factor and speed; and <i>the braking distance is the product of the braking distance (as supplied by the manufacturer), road type, skidding danger, vehicle load and braking factor.</i> The stopping distance (SD) includes further safety factors, and determines when the safety alarm will be actuated to first alert the driver of an approaching collision danger.</p> <p>A determination is also made of the collision distance CD which is equal to the stopping distance SD divided by the collision safety factor CSF, e.g., 1.25 in the example illustrated above, such that should the distance between the vehicle and the</p>	<p><i>stored in a look up table</i> allowing the parameters to be determined from the signals received by the controller together with the parameters defining the normal safety envelope."</p> <p>E.g., page 16, lines 2 to 21, "The control system is designed to activate display 12 to provide a warning signal to a driver of the trailing vehicle when the trailing vehicle 18 when the trailing vehicle is closing too rapidly on the subject vehicle 16 for example, alternately a warning signal is displayed when the trailing vehicle 18 is too close to the subject vehicle 16. Even if they are travelling at the same speed for example, <u>there are known safe stopping distances such as those published by the Minister of Transport</u>, in which a vehicle will stop when the brakes are applied. Accordingly, by knowing the velocity of the subject vehicle 16 for example preferably using the radar ground sensing system described herein, which provides therefore a true ground speed, or other means in communication with a microprocessor control system and by using a proximity sensor 20 to determine the separation of the subject vehicle 16 from the</p>

Limitation of '781 Patent Claim 18	Automotive Electronics Handbook (Jurgen)	U.S. Patent No. 5,477,452 (Saturn '452)	U.S. Patent No. 5,357,438 (Davidian)	PCT Publication No. WO 96/02853 (Tonkin)
			<p>object come within the collision distance CD, the collision alarm is then actuated.</p> <p>The foregoing calculations of stopping distance SD and collision distance CD with respect to objects at the front of the vehicle are also made with respect to objects at the rear of the vehicle, these calculations being RSD and RCD, respectively, also shown in block 162.</p> <p>Whenever the distance between the vehicle and an object to the front of the vehicle or to the rear of the vehicle comes within the stopping distance SD and the collision distance CD, the system operates according to the deceleration alarm module 93, as indicated by block 164.”</p>	<p>trailing vehicle 18 a safety envelope can be created behind the subject vehicle 16. Intrusion in the envelope by the trailing vehicle 18 causes an initial level of lamps 13 in array 12 to be lit.”</p> <p>E.g., page 17, lines 7 to 25, “Thus a warning system has been described using a ground speed sensor for a subject vehicle 16 coupled by a microprocessor with a proximity sensor 20. In a more sophisticate [sic] version, proximity sensor 20 could be a radar device described herein for measuring velocity and could therefore be used to measure the relative velocity of a subject vehicle 16 and trailing vehicle 18. By knowing the closing speed of the trailing vehicle 18 predetermined values could be used to trigger warning displays if the closing speed is too great. <i>For example, a look-up table or database could again be provided for unsafe closing speeds. This look-up table might again be varied according to the velocity of the subject vehicle 16 in a similar manner to the safe stopping distance, or safety envelope distance.</i> Therefore, whilst the safety envelope distance at 30mph is 25 metres, if the trailing vehicle is closing</p>

Limitation of '781 Patent Claim 18	Automotive Electronics Handbook (Jurgen)	U.S. Patent No. 5,477,452 (Saturn '452)	U.S. Patent No. 5,357,438 (Davidian)	PCT Publication No. WO 96/02853 (Tonkin)
				too rapidly, say, a difference in speed of 30mph, then the warning signal could be activated even when the trailing vehicle 18 is 50 metres behind the subject vehicle 16.”

18. Claims 24 and 25 are Obvious in View of the Combination of Jurgen, Saturn '452, Davidian, and Chasteen

Limitation of '781 Patent Claim 24	Automotive Electronics Handbook (Jurgen)	U.S. Patent No. 5,477,452 (Saturn '452)	U.S. Patent No. 5,357,438 (Davidian)	U.S. Patent No. 4,901,701 (Chasteen)
<p>24. Apparatus for optimizing operation of a vehicle according to claim 23 wherein said processor subsystem further comprises:</p>	<p>See claim 23 claim chart, at page A-172.</p>	<p>See claim 23 claim chart, at page A-172.</p>	<p>See claim 23 claim chart, at page A-172.</p>	<p>E.g., col. 1, lines 9 to 13, "The present invention relates generally to two-stroke operating cycle engines and, more particularly, to a two stroke engine fuel injection system and control system therefor which are adapted for extreme weather conditions."</p> <p>E.g., col. 2, lines 2 to 17, "Small, two-cycle engines are especially subject to malfunction under variable operating conditions such as changes in sea level, with associated barometric changes and changes in ambient air temperature. Many machines such as snowmobiles, snowblowers, dirt bikes, etc., are operated in such widely variable operating conditions. In view of the costs associated with engine modification for sensors' need for electronic control of fuel injectors and in view of the fact that the engine parameters which are critical to control of fuel injectors for two-cycle engines were not, prior to the present invention, understood in the art, a successful electronically-controlled fuel injection system for small, two-cycle engines which are subject to extremes in operating conditions has not</p>

Limitation of '781 Patent Claim 24	Automotive Electronics Handbook (Jurgen)	U.S. Patent No. 5,477,452 (Saturn '452)	U.S. Patent No. 5,357,438 (Davidian)	U.S. Patent No. 4,901,701 (Chasteen)
				been developed in the prior art.”
means for determining when road speed for said vehicle is increasing or decreasing;	<p>E.g., page 7.6, “There are several applications for rotational speed sensing. First it is necessary to monitor engine speed. This information is used for transmission control, engine control, cruise control, and possibly for a tachometer. Electronics and electronic sensing in the automobile were brought about by the need for higher efficiency engines, better fuel economy, increased power and performance, and lower emissions. Second, <i>wheel speed sensing is required</i> for use in transmissions, cruise control, speedometers, antilock brake systems (ABS), traction control (ASR), variable ratio power steering assist, four-wheel steering, and possibly in inertial navigation and air bag deployment applications.”</p> <p>E.g., page 7.8, “In electronic transmission applications, <i>information from the road and engine speed sensors</i>, as well as torque data and throttle position are required for the MCU to select the optimum gear ratio.”</p>		E.g., col. 4, lines 60 to 66, “Vehicle 2 is further equipped with <i>a speed sensor 12 which may sense the speed of the vehicle in any known manner</i> , for example using the speed measuring system of the vehicle itself, or a speed measuring system independent of the vehicle, e.g., an acceleration sensor, or by calculations based on the Doppler effect, etc.”	
means for determining when throttle position for said vehicle	E.g., page 12.18, “To control the idle speed, the ECU uses inputs	E.g., col. 2, lines 23 to 36, “Referring to FIG. 1, the shift	E.g., col. 4, lines 60 to 66, “Vehicle 2 is further equipped	E.g., col. 9, lines 3 to 8, “These sensors may include a battery

Limitation of '781 Patent Claim 24	Automotive Electronics Handbook (Jurgen)	U.S. Patent No. 5,477,452 (Saturn '452)	U.S. Patent No. 5,357,438 (Davidian)	U.S. Patent No. 4,901,701 (Chasteen)
<p>is increasing or decreasing; and.</p>	<p>from the <i>throttle position sensor</i>, air conditioning, automatic transmission, power steering, charging system, engine RPM, and vehicle speed.”</p> <p>E.g., page 12.21, “The electronic injection unit also houses the <i>throttle position sensor</i> and, in some cases, an inlet air temperature sensor which provides operating condition information to the ECU.”</p>	<p>indication apparatus with a manual transmission according to the present invention comprises an engine speed sensor 1 for detecting the engine speed and for producing pulse signals of a frequency proportional to the engine speed, a shift position sensor 2 for detecting the shift positions of the transmission, <i>a throttle sensor 3 for detecting the opening degree of the throttle valve by means of, for instance, a potentiometer</i>, an A/D converter 4 for converting analog signals from the throttle valve sensor 3 into digital signals, a microcomputer 5 for performing various calculations in accordance with the different signals from the sensors, and an indicator 10 for indicating the result of the calculations.”</p> <p>E.g., col. 2, lines 52 to 59, “Similarly, the output of <i>the throttle sensor 3</i> is connected through the A/D converter 4 to the input of the I/O port 6 so as to transmit the output signals thereof to the microcomputer 5 through the A/D converter 4 and to store the data corresponding to the throttle value opening into the RAM 9 after converting from the analog signals into the digital signals.”</p>	<p>with <i>a speed sensor 12 which may sense the speed of the vehicle in any known manner</i>, for example using the speed measuring system of the vehicle itself, or a speed measuring system independent of the vehicle, e.g., an acceleration sensor, or by calculations based on the Doppler effect, etc.”</p>	<p>voltage sensor 134, an air temperature sensor 136, an engine temperature sensor 138, an engine speed sensor 140, an ignition timing sensor 142, a barometric pressure sensor 144, and <i>a throttle position sensor 146</i>.”</p> <p>E.g., FIG. 1</p>

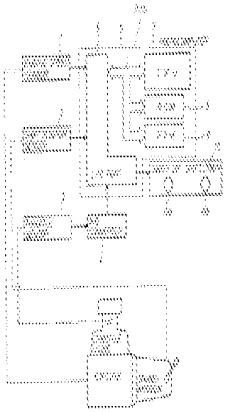
Limitation of '781 Patent Claim 24	Automotive Electronics Handbook (Jurgen)	U.S. Patent No. 5,477,452 (Saturn '452)	U.S. Patent No. 5,357,438 (Davidian)	U.S. Patent No. 4,901,701 (Chasteen)
		<p>E.g., FIG. 1:</p> 		
<p>means for comparing manifold pressure to said manifold pressure set point;</p>	<p>E.g., page 13.5, "The calculators inside the control units are usually microcontrollers. . . .  <i>The memory devices for program and data are usually EPROMS.</i> Their storage capacity is, in present applications, up to 64 Kbytes. Future applications will necessitate storage sizes up to 128 Kbytes. The failure storages for diagnostics and the storage for adaptive data are in conventional applications, battery voltage-supplied RAMs. These are increasingly being replaced by EEPROMs."</p> <p>E.g., page 12.9, "A subsystem of the fuel control system is lambda closed-loop control. . . .</p> <p>[T]he engine control unit uses an anticipatory control strategy that</p>	<p>E.g., col. 2, lines 37 to 42, "The microcomputer 5 further comprises an input/output port (I/O port) 6, a central processing unit (CPU) 7, a <i>read only memory (ROM) 8, and a random access memory (RAM) 9.</i> In the microcomputer 5, there is provided a bus BUS which communicates the I/O port 6 and the CPU 7, <i>ROM 8, and RAM 9.</i>"</p> <p>E.g., col. 3, lines 7 to 20, "<i>The torque data map indicative of torque curves T as shown in FIG. 2 has been stored in the ROM 8 in advance. The fuel consumption rate data map indicative of equal fuel consumption rate curves B as shown in FIG. 3 has been also stored in the ROM 8 in advance. In FIG. 2, each equal torque</i></p>		



Limitation of '781 Patent Claim 24	Automotive Electronics Handbook (Jurgen)	U.S. Patent No. 5,477,452 (Saturn '452)	U.S. Patent No. 5,357,438 (Davidian)	U.S. Patent No. 4,901,701 (Chasteen)
	<p>uses engine load and RPM to determine the approximate fuel requirement. <i>The engine load information is provided by the manifold pressure sensor for speed density systems and by the air meter for air flow and air mass measurement systems and by the throttle valve position sensor. The engine control unit contains data tables for combinations of load and RPM.</i> This allows for rapid response to changes in operating conditions. The lambda sensor still provides the feedback correction for each load/RPM point. . . .</p> <p>E.g., pages 22.2 to 22.3, "The most important test points of control units and sensors are tied to a diagnostic connector which is plugged into the measuring instrument with a corresponding adapter for the respective vehicle. . . .</p> <p><i>Modern electronics in vehicles support diagnosis by comparing the registered actual value with the internally stored nominal values</i> with the help of control units and their self-diagnosis, thus detecting faults."</p>	<p><i>curve T was prepared by plotting and connecting equal torque points on the graph with respect to the engine speed vs. throttle valve opening.</i> In FIG. 3, each fuel consumption rate curve B was prepared by plotting and connecting equal fuel consumption rate points on a graph obtained in advance by experiment data with respect to the engine speed and the torques thus calculated."</p>		
<p>means for determining when manifold pressure for said vehicle is increasing or decreasing; and</p>	<p>E.g., page 2.5, "Automotive specification and testing guidelines have been developed and published by the</p>			

Limitation of '781 Patent Claim 24	Automotive Electronics Handbook (Jurgen)	U.S. Patent No. 5,477,452 (Saturn '452)	U.S. Patent No. 5,357,438 (Davidian)	U.S. Patent No. 4,901,701 (Chasteen)
	<p>Society of Automotive Engineers (SAE) specifically for <i>manifold absolute pressure (MAP) sensors.</i></p> <p>E.g., page 2.7, "Manifold absolute pressure (MAP) is used as an input to fuel and ignition control in internal combustion engine control systems. <i>The speed-density system that uses the MAP sensor</i> has been preferred over mass air flow (MAF) control because it's less expensive, but stricter emission standards are causing more manufacturers to use mass air flow for future models."</p>			
<p>means for determining when engine speed for said vehicle is increasing or decreasing;</p>	<p>E.g., page 7.6, "There are several applications for rotational speed sensing. First it is necessary to monitor engine speed. This information is used for transmission control, engine control, cruise control, and possibly for a tachometer. Electronics and electronic sensing in the automobile were brought about by the need for higher efficiency engines, better fuel economy, increased power and performance, and lower emissions. Second, <i>wheel speed sensing is required</i> for use in transmissions, cruise control, speedometers, antilock brake systems (ABS), traction control</p>	<p>E.g., col. 2, lines 23 to 36, "Referring to FIG. 1, the shift indication apparatus with a manual transmission according to the present invention comprises <i>an engine speed sensor 1 for detecting the engine speed and for producing pulse signals of a frequency proportional to the engine speed</i>, a shift position sensor 2 for detecting the shift positions of the transmission, <i>a throttle sensor 3 for detecting the opening degree of the throttle valve by means of, for instance, a potentiometer</i>, an A/D converter 4 for converting analog signals from the throttle valve sensor 3 into digital signals, a</p>		<p>E.g., col. 9, lines 3 to 8, "These sensors may include a battery voltage sensor 134, an air temperature sensor 136, an engine temperature sensor 138, <i>an engine speed sensor 140</i>, an ignition timing sensor 142, a barometric pressure sensor 144, and a throttle position sensor 146."</p> <p>E.g., FIG. 1</p>

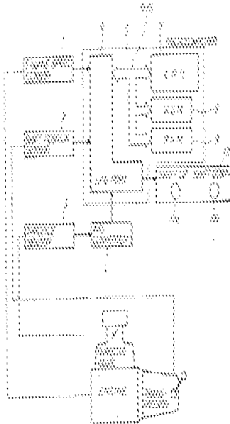
Limitation of '781 Patent Claim 24	Automotive Electronics Handbook (Jurgen)	U.S. Patent No. 5,477,452 (Saturn '452)	U.S. Patent No. 5,357,438 (Davidian)	U.S. Patent No. 4,901,701 (Chasteen)
	<p>(ASR), variable ratio power steering assist, four-wheel steering, and possibly in inertial navigation and air bag deployment applications.”</p> <p>E.g., page 7.8, “In electronic transmission applications, <i>information from the road and engine speed sensors</i>, as well as torque data and throttle position are required for the MCU to select the optimum gear ratio.”</p>	<p>microcomputer 5 for performing various calculations in accordance with the different signals from the sensors, and an indicator 10 for indicating the result of the calculations.”</p> <p>E.g., col. 2, lines 43 to 48, “<i>The engine speed sensor 1</i> is mounted in a distributor (not shown) and the output of the sensor is connected to the input of the I/O port 6 so as to transmit the output pulses to the microcomputer 5 through the I/O port 6 and to store the data corresponding to the engine speed into the RAM 9.”</p> <p>E.g., FIG. 1:</p> 		
<p>said processor subsystem activating said fuel overinjection notification circuit if both road speed and throttle position for said vehicle are increasing and</p>	<p>E.g., page 12.4, “During coasting and braking, fuel consumption can be further reduced by shutting off the fuel until the engine speed decreases</p>			<p>E.g., col. 9, lines 1 to 8, “The electronic control assembly comprises a number of sensors having sensor outputs which are provided to the CPU 130</p>

Limitation of '781 Patent Claim 24	Automotive Electronics Handbook (Jurgen)	U.S. Patent No. 5,477,452 (Saturn '452)	U.S. Patent No. 5,357,438 (Davidian)	U.S. Patent No. 4,901,701 (Chasteen)
<p>manifold pressure for said vehicle is above said manifold pressure set point or if both throttle position and manifold pressure for said vehicle are increasing and road speed and engine speed for said vehicle are decreasing.</p>	<p>to slightly higher than the set idle speed. <i>The ECU determines when fuel shutoff can occur by evaluating the throttle position, engine RPM, and vehicle speed.</i></p> <p>E.g., page 12.14, "Using the inputs of engine RPM and vehicle speed to the electronic control unit, thresholds can be established for limiting these variables with fuel cutoff. <i>When the maximum speed is achieved, the fuel injectors are shut off.</i> When the speed decreases below the threshold, fuel injection resumes."</p>			<p>through interface circuitry 132. These sensors may include a battery voltage sensor 134, an air temperature sensor 136, an engine temperature sensor 138, an engine speed sensor 140, an ignition timing sensor 142, a barometric pressure sensor 144, and a throttle position sensor 146."</p> <p>E.g., col. 9, lines 48 to 55, "The CPU 130 receives and processes the signals from the various sensors described above and generates control signals which are used to control fuel pump speed, to maintain the speed of operation of the fuel pump at a rate which provides a pressure in the circulation conduit portion immediately downstream therefrom which is approximately equal to the preset maximum pressure of the pressure regulator 114."</p> <p>E.g., col. 11, lines 22 to 33, "As indicated at 303 the CPU determines from the reading taken at 302 whether or not the engine RPM is greater than 0. If engine RPM is greater than 0, the CPU next makes the determination from the throttle position reading of 302 whether or not the throttle position is greater than a predetermined</p>

Limitation of '781 Patent Claim 24	Automotive Electronics Handbook (Jurgen)	U.S. Patent No. 5,477,452 (Saturn '452)	U.S. Patent No. 5,357,438 (Davidian)	U.S. Patent No. 4,901,701 (Chasteen)
				<p>amount, such as 20°, as indicated in block 304. If throttle position is less than 20°, the CPU decision-making process returns to block 302. If the throttle position is greater than the predetermined amount and RPM = 0, the CPU provides a control command to the engine fuel injector(s) to prime the engine.”</p> <p>E.g., August 6, 1998 Office Action, “Chasteen discloses the sensors as discussed for sensing the signals and a processor and compare manifold pressure for activating the fuel injection. Chasteen discloses the speed (RPM) and throttle position are determined to be greater than 0 (increasing) and the CPU provides a control command to the engine fuel injector to prime the engine (See column 11, lines 22-33) therefore on [sic] would consider increasing and decreasing the speed and throttle for adjusting the fuel injector for supplying fuel to the engine.”</p>

Limitation of '781 Patent Claim 25	Automotive Electronics Handbook (Jurgen)	U.S. Patent No. 4,559,599 (Toyota '599)	U.S. Patent No. 5,357,438 (Davidian)	U.S. Patent No. 4,901,701 (Chasteen)
<p>25. Apparatus for optimizing operation of a vehicle according to claim 23 wherein said processor subsystem further comprises:</p>	<p>See claim 23 claim chart, at page A-172.</p>	<p>See claim 23 claim chart, at page A-172.</p>	<p>See claim 23 claim chart, at page A-172.</p>	<p>E.g., col. 1, lines 9 to 13, "The present invention relates generally to two-stroke operating cycle engines and, more particularly, to a two stroke engine fuel injection system and control system therefor which are adapted for extreme weather conditions."</p> <p>E.g., col. 2, lines 2 to 17, "Small, two-cycle engines are especially subject to malfunction under variable operating conditions such as changes in sea level, with associated barometric changes and changes in ambient air temperature. Many machines such as snowmobiles, snowblowers, dirt bikes, etc., are operated in such widely variable operating conditions. In view of the costs associated with engine modification for sensors' need for electronic control of fuel injectors and in view of the fact that the engine parameters which are critical to control of fuel injectors for two-cycle engines were not, prior to the present invention, understood in the art, a successful electronically-controlled fuel injection system for small, two-cycle engines which are subject to extremes in operating conditions has not been developed in the prior art."</p>

Limitation of '781 Patent Claim 25	Automotive Electronics Handbook (Jurgen)	U.S. Patent No. 4,559,599 (Toyota '599)	U.S. Patent No. 5,357,438 (Davidian)	U.S. Patent No. 4,901,701 (Chasteen)
means for determining when road speed for said vehicle is increasing;	<p>E.g., page 7.6, "There are several applications for rotational speed sensing. First it is necessary to monitor engine speed. This information is used for transmission control, engine control, cruise control, and possibly for a tachometer. Electronics and electronic sensing in the automobile were brought about by the need for higher efficiency engines, better fuel economy, increased power and performance, and lower emissions. Second, <i>wheel speed sensing is required</i> for use in transmissions, cruise control, speedometers, antilock brake systems (ABS), traction control (ASR), variable ratio power steering assist, four-wheel steering, and possibly in inertial navigation and air bag deployment applications."</p> <p>E.g., page 7.8, "In electronic transmission applications, <i>information from the road and engine speed sensors</i>, as well as torque data and throttle position are required for the MCU to select the optimum gear ratio."</p>		E.g., col. 4, lines 60 to 66, "Vehicle 2 is further equipped with <i>a speed sensor 12 which may sense the speed of the vehicle in any known manner</i> , for example using the speed measuring system of the vehicle itself, or a speed measuring system independent of the vehicle, e.g., an acceleration sensor, or by calculations based on the Doppler effect, etc."	
means for determining when throttle position for said vehicle is increasing;	E.g., page 12.18, "To control the idle speed, the ECU uses inputs from the <i>throttle position sensor</i> , air conditioning, automatic transmission, power	E.g., col. 2, lines 23 to 36, "Referring to FIG. 1, the shift indication apparatus with a manual transmission according to the present invention comprises	E.g., col. 4, lines 60 to 66, "Vehicle 2 is further equipped with <i>a speed sensor 12 which may sense the speed of the vehicle in any known manner</i> ,	E.g., col. 9, lines 3 to 8, "These sensors may include a battery voltage sensor 134, an air temperature sensor 136, an engine temperature sensor 138,

Limitation of '781 Patent Claim 25	Automotive Electronics Handbook (Jurgen)	U.S. Patent No. 4,559,599 (Toyota '599)	U.S. Patent No. 5,357,438 (Davidian)	U.S. Patent No. 4,901,701 (Chasteen)
	<p>steering, charging system, engine RPM, and vehicle speed.”</p> <p>E.g., page 12.21, “The electronic injection unit also houses the <i>throttle position sensor</i> and, in some cases, an inlet air temperature sensor which provides operating condition information to the ECU.”</p>	<p>an engine speed sensor 1 for detecting the engine speed and for producing pulse signals of a frequency proportional to the engine speed, a shift position sensor 2 for detecting the shift positions of the transmission, <i>a throttle sensor 3 for detecting the opening degree of the throttle valve by means of, for instance, a potentiometer</i>, an A/D converter 4 for converting analog signals from the throttle valve sensor 3 into digital signals, a microcomputer 5 for performing various calculations in accordance with the different signals from the sensors, and an indicator 10 for indicating the result of the calculations.”</p> <p>E.g., col. 2, lines 52 to 59, “Similarly, the output of <i>the throttle sensor 3</i> is connected through the A/D converter 4 to the input of the I/O port 6 so as to transmit the output signals thereof to the microcomputer 5 through the A/D converter 4 and to store the data corresponding to the throttle value opening into the RAM 9 after converting from the analog signals into the digital signals.”</p> <p>E.g., FIG. 1:</p>	<p>for example using the speed measuring system of the vehicle itself, or a speed measuring system independent of the vehicle, e.g., an acceleration sensor, or by calculations based on the Doppler effect, etc.”</p>	<p>an engine speed sensor 140, an ignition timing sensor 142, a barometric pressure sensor 144, and <i>a throttle position sensor 146</i>.”</p> <p>E.g., FIG. 1</p>

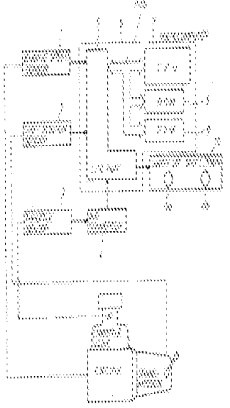

Limitation of '781 Patent Claim 25	Automotive Electronics Handbook (Jurgen)	U.S. Patent No. 4,559,599 (Toyota '599)	U.S. Patent No. 5,357,438 (Davidian)	U.S. Patent No. 4,901,701 (Chasteen)
				
<p>means for comparing manifold pressure to said manifold pressure set point; and</p>	<p>E.g., page 13.5, “The calculators inside the control units are usually microcontrollers. . . .  <i>The memory devices for program and data are usually EPROMS.</i> Their storage capacity is, in present applications, up to 64 Kbytes. Future applications will necessitate storage sizes up to 128 Kbytes. The failure storages for diagnostics and the storage for adaptive data are in conventional applications, battery voltage-supplied RAMs. These are increasingly being replaced by EEPROMs.”</p> <p>E.g., page 12.9, “A subsystem of the fuel control system is lambda closed-loop control. . . .</p> <p>[T]he engine control unit uses an anticipatory control strategy that uses engine load and RPM to</p>	<p>E.g., col. 2, lines 37 to 42, “The microcomputer 5 further comprises an input/output port (I/O port) 6, a central processing unit (CPU) 7, a <i>read only memory (ROM) 8, and a random access memory (RAM) 9.</i> In the microcomputer 5, there is provided a bus BUS which communicates the I/O port 6 and the CPU 7, <i>ROM 8, and RAM 9.</i>”</p> <p>E.g., col. 3, lines 7 to 20, “<i>The torque data map indicative of torque curves T as shown in FIG. 2 has been stored in the ROM 8 in advance. The fuel consumption rate data map indicative of equal fuel consumption rate curves B as shown in FIG. 3 has been also stored in the ROM 8 in advance. In FIG. 2, each equal torque curve T was prepared by plotting</i></p>		

Limitation of '781 Patent Claim 25	Automotive Electronics Handbook (Jurgen)	U.S. Patent No. 4,559,599 (Toyota '599)	U.S. Patent No. 5,357,438 (Davidian)	U.S. Patent No. 4,901,701 (Chasteen)
	<p>determine the approximate fuel requirement. <i>The engine load information is provided by the manifold pressure sensor for speed density systems and by the air meter for air flow and air mass measurement systems and by the throttle valve position sensor. The engine control unit contains data tables for combinations of load and RPM.</i> This allows for rapid response to changes in operating conditions. The lambda sensor still provides the feedback correction for each load/RPM point. . . .</p> <p>E.g., pages 22.2 to 22.3, "The most important test points of control units and sensors are tied to a diagnostic connector which is plugged into the measuring instrument with a corresponding adapter for the respective vehicle. . . .</p> <p><i>Modern electronics in vehicles support diagnosis by comparing the registered actual value with the internally stored nominal values</i> with the help of control units and their self-diagnosis, thus detecting faults."</p>	<p><i>and connecting equal torque points on the graph with respect to the engine speed vs. throttle valve opening.</i> In FIG. 3, each fuel consumption rate curve B was prepared by plotting and connecting equal fuel consumption rate points on a graph obtained in advance by experiment data with respect to the engine speed and the torques thus calculated."</p>		
means for comparing engine speed to said RPM set point;	E.g., page 13.7 to 13.9, " <i>The basic functions of the transmission control are the shift point control</i> , the lockup	E.g., col. 2, lines 37 to 42, "The microcomputer 5 further comprises an input/output port (I/O port) 6, a central processing		E.g., col. 11, lines 22 to 33, " <i>As indicated at 303 the CPU determines from the reading taken at 302 whether or not the</i>

Limitation of '781 Patent Claim 25	Automotive Electronics Handbook (Jurgen)	U.S. Patent No. 4,559,599 (Toyota '599)	U.S. Patent No. 5,357,438 (Davidian)	U.S. Patent No. 4,901,701 (Chasteen)
	<p>control, engine torque control during shifting, related safety functions, and diagnostic functions for vehicle service.”</p> <p>E.g., page 13.9, “The basic shift point control uses shift maps, which are defined in data in the unit memory. These shift maps are selectable over a wide range. <i>The shift point limitations are made</i>, on the one hand, by the highest admissible engine speed for each application and, on the other hand, <i>by the lowest engine speed that is practical for driving comfort and noise emission. The inputs of the shift point determination are the throttle position, the accelerator pedal position, and the vehicle speed</i> (determined by the transmission output speed).”</p>	<p>unit (CPU) 7, a <i>read only memory (ROM) 8, and a random access memory (RAM) 9</i>. In the microcomputer 5, there is provided a bus BUS which communicates the I/O port 6 and the CPU 7, <i>ROM 8, and RAM 9</i>.”</p> <p>E.g., col. 3, lines 7 to 20, “<i>The torque data map indicative of torque curves T as shown in FIG. 2 has been stored in the ROM 8 in advance. The fuel consumption rate data map indicative of equal fuel consumption rate curves B as shown in FIG. 3 has been also stored in the ROM 8 in advance. In FIG. 2, each equal torque curve T was prepared by plotting and connecting equal torque points on the graph with respect to the engine speed vs. throttle valve opening. In FIG. 3, each fuel consumption rate curve B was prepared by plotting and connecting equal fuel consumption rate points on a graph obtained in advance by experiment data with respect to the engine speed and the torques thus calculated.</i>”</p> <p>E.g., col. 3, lines 44 to 61, “<i>In this case, as shown in FIG. 4, the operation of a main routine is started at a predetermined</i></p>		<p><i>engine RPM is greater than 0. If engine RPM is greater than 0, the CPU next makes the determination from the throttle position reading of 302 whether or not the throttle position is greater than a predetermined amount, such as 20°, as indicated in block 304. If throttle position is less than 20°, the CPU decision-making process returns to block 302. If the throttle position is greater than the predetermined amount and RPM = 0, the CPU provides a control command to the engine fuel injector(s) to prime the engine.</i>”</p>

Limitation of '781 Patent Claim 25	Automotive Electronics Handbook (Jurgen)	U.S. Patent No. 4,559,599 (Toyota '599)	U.S. Patent No. 5,357,438 (Davidian)	U.S. Patent No. 4,901,701 (Chasteen)
		<p><i>timing, e.g. periodical timing pulses from a timer (not shown) and the detection of the engine speed <math>N_e</math> from the sensor 1 is carried out and it is stored into the RAM 9 at the step 20. Then, the engine speed <math>N_e</math> is read from the RAM 9 and it is compared with a predetermined number <math>N</math> (=1000 rpm) to determine whether or not the <math>N_e</math> exceeds the value 1000 at the step 21. If the result of the decision is YES, the next step 22 is executed. That is, in the step 22, the reading in of the opening of the throttle valve is performed through the throttle sensor 3 and the A/D converter 4. In the above case, if the result of the decision in step 21 is NO, the main routine is terminated by determining that the shift operation is not necessary and the engine speed <math>N_e</math> is read again at the predetermined timing and now the operation returns to the step 20."</i></p> <p>E.g., Figure 4:</p>		

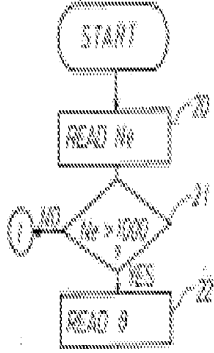
Limitation of '781 Patent Claim 25	Automotive Electronics Handbook (Jurgen)	U.S. Patent No. 4,559,599 (Toyota '599)	U.S. Patent No. 5,357,438 (Davidian)	U.S. Patent No. 4,901,701 (Chasteen)
		 <pre> graph TD     START([START]) --&gt; READ_N[READ N]     READ_N --&gt; DEC{N &gt; MAX}     DEC -- YES --&gt; READ_0[READ 0]     DEC -- NO --&gt; READ_N </pre>		
<p>said processor subsystem activating said upshift notification circuit if both road speed and throttle position for said vehicle are increasing, manifold pressure for said vehicle is at or below said manifold pressure set point and engine speed for said vehicle is at or above said RPM set point.</p>	<p>E.g., page 13.7 to 13.9, <i>“The basic functions of the transmission control are the shift point control, the lockup control, engine torque control during shifting, related safety functions, and diagnostic functions for vehicle service.”</i>  E.g., page 13.9, <i>“The basic shift point control uses shift maps, which are defined in data in the unit memory. These shift maps are selectable over a wide range. The shift point limitations are made, on the one hand, by the highest admissible engine speed for each application and, on the other hand, by the lowest engine speed that is practical for driving comfort and noise emission. The inputs of the shift point determination are the throttle position, the accelerator pedal position, and the vehicle speed (determined by the</i></p>	<p>E.g., col. 2, lines 37 to 42, <i>“The microcomputer 5 further comprises an input/output port (I/O port) 6, a central processing unit (CPU) 7, a read only memory (ROM) 8, and a random access memory (RAM) 9. In the microcomputer 5, there is provided a bus BUS which communicates the I/O port 6 and the CPU 7, ROM 8, and RAM 9.”</i>   E.g., col. 2, lines 59 to 63, <i>“The input of the indicator 10 is connected to the output of the I/O port 6 so as to indicate each preferable shift position corresponding to the optimum fuel consumption rate in accordance with various parameters calculated.”</i>   E.g., col. 5, line 63 to col. 6, line 2, <i>“Namely, in this step, the speed change operation</i></p>		<p>E.g., col. 9, lines 1 to 8, <i>“The electronic control assembly comprises a number of sensors having sensor outputs which are provided to the CPU 130 through interface circuitry 132. These sensors may include a battery voltage sensor 134, an air temperature sensor 136, an engine temperature sensor 138, an engine speed sensor 140, an ignition timing sensor 142, a barometric pressure sensor 144, and a throttle position sensor 146.”</i>   E.g., col. 9, lines 48 to 55, <i>“The CPU 130 receives and processes the signals from the various sensors described above and generates control signals which are used to control fuel pump speed, to maintain the speed of operation of the fuel pump at a rate which provides a pressure in</i></p>

Limitation of '781 Patent Claim 25	Automotive Electronics Handbook (Jurgen)	U.S. Patent No. 4,559,599 (Toyota '599)	U.S. Patent No. 5,357,438 (Davidian)	U.S. Patent No. 4,901,701 (Chasteen)
	transmission output speed).”	<i>indicating signal is applied to the indicator or display 10 from the microcomputer 5 through the I/O port 6. As a result, a particular lamp in this case, a shift up indicating lamp in the indicator 10, is illuminated, thus indicating to the drive that the speed change from current shift position to the one step shifting up position SP<sub>+1</sub> is preferable.”</i>		<p>the circulation conduit portion immediately downstream therefrom which is approximately equal to the preset maximum pressure of the pressure regulator 114.”</p> <p>E.g., col. 11, lines 22 to 33, “As indicated at 303 the CPU determines from the reading taken at 302 whether or not the engine RPM is greater than 0. If engine RPM is greater than 0, the CPU next makes the determination from the throttle position reading of 302 whether or not the throttle position is greater than a predetermined amount, such as 20°, as indicated in block 304. If throttle position is less than 20°, the CPU decision-making process returns to block 302. If the throttle position is greater than the predetermined amount and RPM = 0, the CPU provides a control command to the engine fuel injector(s) to prime the engine.”</p> <p>E.g., August 6, 1998 Office Action, “Chasteen discloses the sensors as discussed for sensing the signals and a processor and compare manifold pressure for activating the fuel injection. Chasteen discloses the speed (RPM) and throttle position are determined to be greater than 0</p>

Limitation of '781 Patent Claim 25	Automotive Electronics Handbook (Jurgen)	U.S. Patent No. 4,559,599 (Toyota '599)	U.S. Patent No. 5,357,438 (Davidian)	U.S. Patent No. 4,901,701 (Chasteen)
				(increasing) and the CPU provides a control command to the engine fuel injector to prime the engine (See column 11, lines 22-33) therefore on [sic] would consider increasing and decreasing the speed and throttle for adjusting the fuel injector for supplying fuel to the engine."

19. Claims 24, 25, and 27 are Obvious in View of the Combination of Jurgen, Toyota '599, Davidian, and Chasteen

Limitation of '781 Patent Claim 24	Automotive Electronics Handbook (Jurgen)	U.S. Patent No. 4,559,599 (Toyota '599)	U.S. Patent No. 5,357,438 (Davidian)	U.S. Patent No. 4,901,701 (Chasteen)
<p>24. Apparatus for optimizing operation of a vehicle according to claim 23 wherein said processor subsystem further comprises:</p>	<p>See claim 23 claim chart, at page A-79.</p>	<p>See claim 23 claim chart, at page A-79.</p>	<p>See claim 23 claim chart, at page A-79.</p>	<p>E.g., col. 1, lines 9 to 13, "The present invention relates generally to two-stroke operating cycle engines and, more particularly, to a two stroke engine fuel injection system and control system therefor which are adapted for extreme weather conditions."</p> <p>E.g., col. 2, lines 2 to 17, "Small, two-cycle engines are especially subject to malfunction under variable operating conditions such as changes in sea level, with associated barometric changes and changes in ambient air temperature. Many machines such as snowmobiles, snowblowers, dirt bikes, etc., are operated in such widely variable operating conditions. In view of the costs associated with engine modification for sensors' need for electronic control of fuel injectors and in view of the fact that the engine parameters which are critical to control of fuel injectors for two-cycle engines were not, prior to the present invention, understood in the art, a successful electronically-controlled fuel injection system for small, two-cycle engines which are subject to extremes in operating conditions has not</p>



Limitation of '781 Patent Claim 24	Automotive Electronics Handbook (Jurgen)	U.S. Patent No. 4,559,599 (Toyota '599)	U.S. Patent No. 5,357,438 (Davidian)	U.S. Patent No. 4,901,701 (Chasteen)
				been developed in the prior art.”
means for determining when road speed for said vehicle is increasing or decreasing;	<p>E.g., page 7.6, “There are several applications for rotational speed sensing. First it is necessary to monitor engine speed. This information is used for transmission control, engine control, cruise control, and possibly for a tachometer. Electronics and electronic sensing in the automobile were brought about by the need for higher efficiency engines, better fuel economy, increased power and performance, and lower emissions. Second, <i>wheel speed sensing is required</i> for use in transmissions, cruise control, speedometers, antilock brake systems (ABS), traction control (ASR), variable ratio power steering assist, four-wheel steering, and possibly in inertial navigation and air bag deployment applications.”</p> <p>E.g., page 7.8, “In electronic transmission applications, <i>information from the road and engine speed sensors</i>, as well as torque data and throttle position are required for the MCU to select the optimum gear ratio.”</p>		E.g., col. 4, lines 60 to 66, “Vehicle 2 is further equipped with <i>a speed sensor 12 which may sense the speed of the vehicle in any known manner</i> , for example using the speed measuring system of the vehicle itself, or a speed measuring system independent of the vehicle, e.g., an acceleration sensor, or by calculations based on the Doppler effect, etc.”	
means for determining when throttle position for said vehicle is increasing or decreasing; and.	E.g., page 12.18, “To control the idle speed, the ECU uses inputs from the <i>throttle position</i>	E.g., col. 2, lines 23 to 36, “Referring to FIG. 1, the shift indication apparatus with a	E.g., col. 4, lines 60 to 66, “Vehicle 2 is further equipped with <i>a speed sensor 12 which</i>	E.g., col. 9, lines 3 to 8, “These sensors may include a battery voltage sensor 134, an air

Limitation of '781 Patent Claim 24	Automotive Electronics Handbook (Jurgen)	U.S. Patent No. 4,559,599 (Toyota '599)	U.S. Patent No. 5,357,438 (Davidian)	U.S. Patent No. 4,901,701 (Chasteen)
	<p><i>sensor</i>, air conditioning, automatic transmission, power steering, charging system, engine RPM, and vehicle speed.”</p> <p>E.g., page 12.21, “The electronic injection unit also houses the <i>throttle position sensor</i> and, in some cases, an inlet air temperature sensor which provides operating condition information to the ECU.”</p>	<p>manual transmission according to the present invention comprises an engine speed sensor 1 for detecting the engine speed and for producing pulse signals of a frequency proportional to the engine speed, a shift position sensor 2 for detecting the shift positions of the transmission, <i>a throttle sensor 3 for detecting the opening degree of the throttle valve by means of, for instance, a potentiometer</i>, an A/D converter 4 for converting analog signals from the throttle valve sensor 3 into digital signals, a microcomputer 5 for performing various calculations in accordance with the different signals from the sensors, and an indicator 10 for indicating the result of the calculations.”</p> <p>E.g., col. 2, lines 52 to 59, “Similarly, the output of <i>the throttle sensor 3</i> is connected through the A/D converter 4 to the input of the I/O port 6 so as to transmit the output signals thereof to the microcomputer 5 through the A/D converter 4 and to store the data corresponding to the throttle value opening into the RAM 9 after converting from the analog signals into the digital signals.”</p> <p>E.g., FIG. 1:</p>	<p><i>may sense the speed of the vehicle in any known manner</i>, for example using the speed measuring system of the vehicle itself, or a speed measuring system independent of the vehicle, e.g., an acceleration sensor, or by calculations based on the Doppler effect, etc.”</p>	<p>temperature sensor 136, an engine temperature sensor 138, an engine speed sensor 140, an ignition timing sensor 142, a barometric pressure sensor 144, and <i>a throttle position sensor 146.</i>”</p> <p>E.g., FIG. 1</p>

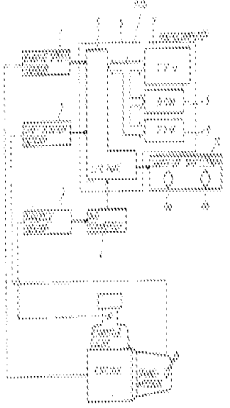
Limitation of '781 Patent Claim 24	Automotive Electronics Handbook (Jurgen)	U.S. Patent No. 4,559,599 (Toyota '599)	U.S. Patent No. 5,357,438 (Davidian)	U.S. Patent No. 4,901,701 (Chasteen)
				
<p>means for comparing manifold pressure to said manifold pressure set point;</p>	<p>E.g., page 13.5, “The calculators inside the control units are usually microcontrollers. . . .  <i>The memory devices for program and data are usually EPROMS.</i> Their storage capacity is, in present applications, up to 64 Kbytes. Future applications will necessitate storage sizes up to 128 Kbytes. The failure storages for diagnostics and the storage for adaptive data are in conventional applications, battery voltage-supplied RAMs. These are increasingly being replaced by EEPROMs.”</p> <p>E.g., page 12.9, “A subsystem of the fuel control system is lambda closed-loop control. . . .</p> <p>[T]he engine control unit uses an anticipatory control strategy that uses engine load and RPM to</p>	<p>E.g., col. 2, lines 37 to 42, “The microcomputer 5 further comprises an input/output port (I/O port) 6, a central processing unit (CPU) 7, a read only memory (ROM) 8, and a random access memory (RAM) 9. In the microcomputer 5, there is provided a bus BUS which communicates the I/O port 6 and the CPU 7, ROM 8, and RAM 9.”</p> <p>E.g., col. 3, lines 7 to 20, “<i>The torque data map indicative of torque curves T as shown in FIG. 2 has been stored in the ROM 8 in advance. The fuel consumption rate data map indicative of equal fuel consumption rate curves B as shown in FIG. 3 has been also stored in the ROM 8 in advance. In FIG. 2, each equal torque curve T was prepared by plotting</i></p>		

Limitation of '781 Patent Claim 24	Automotive Electronics Handbook (Jurgen)	U.S. Patent No. 4,559,599 (Toyota '599)	U.S. Patent No. 5,357,438 (Davidian)	U.S. Patent No. 4,901,701 (Chasteen)
	<p>determine the approximate fuel requirement. <i>The engine load information is provided by the manifold pressure sensor for speed density systems and by the air meter for air flow and air mass measurement systems and by the throttle valve position sensor. The engine control unit contains data tables for combinations of load and RPM.</i> This allows for rapid response to changes in operating conditions. The lambda sensor still provides the feedback correction for each load/RPM point. . . .</p> <p>E.g., pages 22.2 to 22.3, "The most important test points of control units and sensors are tied to a diagnostic connector which is plugged into the measuring instrument with a corresponding adapter for the respective vehicle. . . .</p> <p><i>Modern electronics in vehicles support diagnosis by comparing the registered actual value with the internally stored nominal values</i> with the help of control units and their self-diagnosis, thus detecting faults."</p>	<p><i>and connecting equal torque points on the graph with respect to the engine speed vs. throttle valve opening.</i> In FIG. 3, each fuel consumption rate curve B was prepared by plotting and connecting equal fuel consumption rate points on a graph obtained in advance by experiment data with respect to the engine speed and the torques thus calculated."</p>		
<p>means for determining when manifold pressure for said vehicle is increasing or decreasing; and</p>	<p>E.g., page 2.5, "Automotive specification and testing guidelines have been developed and published by the Society of Automotive</p>			

Limitation of '781 Patent Claim 24	Automotive Electronics Handbook (Jurgen)	U.S. Patent No. 4,559,599 (Toyota '599)	U.S. Patent No. 5,357,438 (Davidian)	U.S. Patent No. 4,901,701 (Chasteen)
	<p>Engineers (SAE) specifically for <i>manifold absolute pressure (MAP) sensors.</i>"</p> <p>E.g., page 2.7, "Manifold absolute pressure (MAP) is used as an input to fuel and ignition control in internal combustion engine control systems. <i>The speed-density system that uses the MAP sensor</i> has been preferred over mass air flow (MAF) control because it's less expensive, but stricter emission standards are causing more manufacturers to use mass air flow for future models."</p>			
<p>means for determining when engine speed for said vehicle is increasing or decreasing;</p>	<p>E.g., page 7.6, "There are several applications for rotational speed sensing. First it is necessary to monitor engine speed. This information is used for transmission control, engine control, cruise control, and possibly for a tachometer. Electronics and electronic sensing in the automobile were brought about by the need for higher efficiency engines, better fuel economy, increased power and performance, and lower emissions. Second, <i>wheel speed sensing is required</i> for use in transmissions, cruise control, speedometers, antilock brake systems (ABS), traction control (ASR), variable ratio power</p>	<p>E.g., col. 2, lines 23 to 36, "Referring to FIG. 1, the shift indication apparatus with a manual transmission according to the present invention comprises <i>an engine speed sensor 1 for detecting the engine speed and for producing pulse signals of a frequency proportional to the engine speed</i>, a shift position sensor 2 for detecting the shift positions of the transmission, <i>a throttle sensor 3 for detecting the opening degree of the throttle valve by means of, for instance, a potentiometer</i>, an A/D converter 4 for converting analog signals from the throttle valve sensor 3 into digital signals, a microcomputer 5 for performing</p>		<p>E.g., col. 9, lines 3 to 8, "These sensors may include a battery voltage sensor 134, an air temperature sensor 136, an engine temperature sensor 138, <i>an engine speed sensor 140</i>, an ignition timing sensor 142, a barometric pressure sensor 144, and a throttle position sensor 146."</p> <p>E.g., FIG. 1</p>

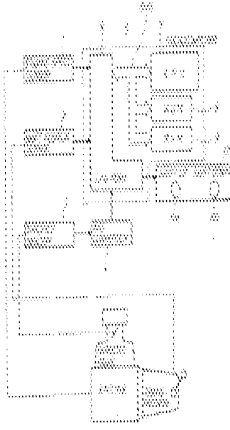
Limitation of '781 Patent Claim 24	Automotive Electronics Handbook (Jurgen)	U.S. Patent No. 4,559,599 (Toyota '599)	U.S. Patent No. 5,357,438 (Davidian)	U.S. Patent No. 4,901,701 (Chasteen)
	<p>steering assist, four-wheel steering, and possibly in inertial navigation and air bag deployment applications.”</p> <p>E.g., page 7.8, “In electronic transmission applications, <i>information from the road and engine speed sensors</i>, as well as torque data and throttle position are required for the MCU to select the optimum gear ratio.”</p>	<p>various calculations in accordance with the different signals from the sensors, and an indicator 10 for indicating the result of the calculations.”</p> <p>E.g., col. 2, lines 43 to 48, “<i>The engine speed sensor 1</i> is mounted in a distributor (not shown) and the output of the sensor is connected to the input of the I/O port 6 so as to transmit the output pulses to the microcomputer 5 through the I/O port 6 and to store the data corresponding to the engine speed into the RAM 9.”</p> <p>E.g., FIG. 1:</p> 		
<p>said processor subsystem activating said fuel overinjection notification circuit if both road speed and throttle position for said vehicle are increasing and manifold pressure for said</p>	<p>E.g., page 12.4, “During coasting and braking, fuel consumption can be further reduced by shutting off the fuel until the engine speed decreases to slightly higher than the set</p>			<p>E.g., col. 9, lines 1 to 8, “The electronic control assembly comprises a number of sensors having sensor outputs which are provided to the CPU 130 through interface circuitry 132.</p>

Limitation of '781 Patent Claim 24	Automotive Electronics Handbook (Jurgen)	U.S. Patent No. 4,559,599 (Toyota '599)	U.S. Patent No. 5,357,438 (Davidian)	U.S. Patent No. 4,901,701 (Chasteen)
<p>vehicle is above said manifold pressure set point or if both throttle position and manifold pressure for said vehicle are increasing and road speed and engine speed for said vehicle are decreasing.</p>	<p>idle speed. <i>The ECU determines when fuel shutoff can occur by evaluating the throttle position, engine RPM, and vehicle speed.</i></p> <p>E.g., page 12.14, "Using the inputs of engine RPM and vehicle speed to the electronic control unit, thresholds can be established for limiting these variables with fuel cutoff. <i>When the maximum speed is achieved, the fuel injectors are shut off.</i> When the speed decreases below the threshold, fuel injection resumes."</p>			<p>These sensors may include a battery voltage sensor 134, an air temperature sensor 136, an engine temperature sensor 138, an engine speed sensor 140, an ignition timing sensor 142, a barometric pressure sensor 144, and a throttle position sensor 146."</p> <p>E.g., col. 9, lines 48 to 55, "The CPU 130 receives and processes the signals from the various sensors described above and generates control signals which are used to control fuel pump speed, to maintain the speed of operation of the fuel pump at a rate which provides a pressure in the circulation conduit portion immediately downstream therefrom which is approximately equal to the preset maximum pressure of the pressure regulator 114."</p> <p>E.g., col. 11, lines 22 to 33, "As indicated at 303 the CPU determines from the reading taken at 302 whether or not the engine RPM is greater than 0. If engine RPM is greater than 0, the CPU next makes the determination from the throttle position reading of 302 whether or not the throttle position is greater than a predetermined amount, such as 20°, as indicated</p>

Limitation of '781 Patent Claim 24	Automotive Electronics Handbook (Jurgen)	U.S. Patent No. 4,559,599 (Toyota '599)	U.S. Patent No. 5,357,438 (Davidian)	U.S. Patent No. 4,901,701 (Chasteen)
				<p>in block 304. If throttle position is less than 20°, the CPU decision-making process returns to block 302. If the throttle position is greater than the predetermined amount and RPM = 0, the CPU provides a control command to the engine fuel injector(s) to prime the engine.”</p> <p>E.g., August 6, 1998 Office Action, “Chasteen discloses the sensors as discussed for sensing the signals and a processor and compare manifold pressure for activating the fuel injection. Chasteen discloses the speed (RPM) and throttle position are determined to be greater than 0 (increasing) and the CPU provides a control command to the engine fuel injector to prime the engine (See column 11, lines 22-33) therefore on [sic] would consider increasing and decreasing the speed and throttle for adjusting the fuel injector for supplying fuel to the engine.”</p>



Limitation of '781 Patent Claim 25	Automotive Electronics Handbook (Jurgen)	U.S. Patent No. 4,559,599 (Toyota '599)	U.S. Patent No. 5,357,438 (Davidian)	U.S. Patent No. 4,901,701 (Chasteen)
<p>25. Apparatus for optimizing operation of a vehicle according to claim 23 wherein said processor subsystem further comprises:</p>	<p>See claim 23 claim chart, at page A-79.</p>	<p>See claim 23 claim chart, at page A-79.</p>	<p>See claim 23 claim chart, at page A-79.</p>	<p>E.g., col. 1, lines 9 to 13, "The present invention relates generally to two-stroke operating cycle engines and, more particularly, to a two stroke engine fuel injection system and control system therefor which are adapted for extreme weather conditions."</p> <p>E.g., col. 2, lines 2 to 17, "Small, two-cycle engines are especially subject to malfunction under variable operating conditions such as changes in sea level, with associated barometric changes and changes in ambient air temperature. Many machines such as snowmobiles, snowblowers, dirt bikes, etc., are operated in such widely variable operating conditions. In view of the costs associated with engine modification for sensors' need for electronic control of fuel injectors and in view of the fact that the engine parameters which are critical to control of fuel injectors for two-cycle engines were not, prior to the present invention, understood in the art, a successful electronically-controlled fuel injection system for small, two-cycle engines which are subject to extremes in operating conditions has not been developed in the prior art."</p>

Limitation of '781 Patent Claim 25	Automotive Electronics Handbook (Jurgen)	U.S. Patent No. 4,559,599 (Toyota '599)	U.S. Patent No. 5,357,438 (Davidian)	U.S. Patent No. 4,901,701 (Chasteen)
means for determining when road speed for said vehicle is increasing;	<p>E.g., page 7.6, "There are several applications for rotational speed sensing. First it is necessary to monitor engine speed. This information is used for transmission control, engine control, cruise control, and possibly for a tachometer. Electronics and electronic sensing in the automobile were brought about by the need for higher efficiency engines, better fuel economy, increased power and performance, and lower emissions. Second, <i>wheel speed sensing is required</i> for use in transmissions, cruise control, speedometers, antilock brake systems (ABS), traction control (ASR), variable ratio power steering assist, four-wheel steering, and possibly in inertial navigation and air bag deployment applications."</p> <p>E.g., page 7.8, "In electronic transmission applications, <i>information from the road and engine speed sensors</i>, as well as torque data and throttle position are required for the MCU to select the optimum gear ratio."</p>		E.g., col. 4, lines 60 to 66, "Vehicle 2 is further equipped with <i>a speed sensor 12 which may sense the speed of the vehicle in any known manner</i> , for example using the speed measuring system of the vehicle itself, or a speed measuring system independent of the vehicle, e.g., an acceleration sensor, or by calculations based on the Doppler effect, etc."	
means for determining when throttle position for said vehicle is increasing;	E.g., page 12.18, "To control the idle speed, the ECU uses inputs from the <i>throttle position sensor</i> , air conditioning, automatic transmission, power	E.g., col. 2, lines 23 to 36, "Referring to FIG. 1, the shift indication apparatus with a manual transmission according to the present invention comprises	E.g., col. 4, lines 60 to 66, "Vehicle 2 is further equipped with <i>a speed sensor 12 which may sense the speed of the vehicle in any known manner</i> ,	E.g., col. 9, lines 3 to 8, "These sensors may include a battery voltage sensor 134, an air temperature sensor 136, an engine temperature sensor 138,

Limitation of '781 Patent Claim 25	Automotive Electronics Handbook (Jurgen)	U.S. Patent No. 4,559,599 (Toyota '599)	U.S. Patent No. 5,357,438 (Davidian)	U.S. Patent No. 4,901,701 (Chasteen)
	<p>steering, charging system, engine RPM, and vehicle speed.”</p> <p>E.g., page 12.21, “The electronic injection unit also houses the <i>throttle position sensor</i> and, in some cases, an inlet air temperature sensor which provides operating condition information to the ECU.”</p>	<p>an engine speed sensor 1 for detecting the engine speed and for producing pulse signals of a frequency proportional to the engine speed, a shift position sensor 2 for detecting the shift positions of the transmission, <i>a throttle sensor 3 for detecting the opening degree of the throttle valve by means of, for instance, a potentiometer</i>, an A/D converter 4 for converting analog signals from the throttle valve sensor 3 into digital signals, a microcomputer 5 for performing various calculations in accordance with the different signals from the sensors, and an indicator 10 for indicating the result of the calculations.”</p> <p>E.g., col. 2, lines 52 to 59, “Similarly, the output of <i>the throttle sensor 3</i> is connected through the A/D converter 4 to the input of the I/O port 6 so as to transmit the output signals thereof to the microcomputer 5 through the A/D converter 4 and to store the data corresponding to the throttle value opening into the RAM 9 after converting from the analog signals into the digital signals.”</p> <p>E.g., FIG. 1:</p>	<p>for example using the speed measuring system of the vehicle itself, or a speed measuring system independent of the vehicle, e.g., an acceleration sensor, or by calculations based on the Doppler effect, etc.”</p>	<p>an engine speed sensor 140, an ignition timing sensor 142, a barometric pressure sensor 144, and <i>a throttle position sensor 146</i>.”</p> <p>E.g., FIG. 1</p>

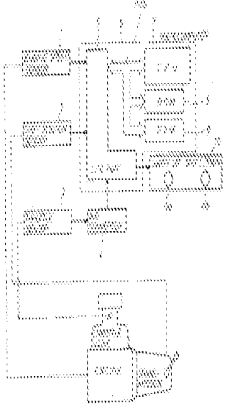
Limitation of '781 Patent Claim 25	Automotive Electronics Handbook (Jurgen)	U.S. Patent No. 4,559,599 (Toyota '599)	U.S. Patent No. 5,357,438 (Davidian)	U.S. Patent No. 4,901,701 (Chasteen)
				
<p>means for comparing manifold pressure to said manifold pressure set point; and</p>	<p>E.g., page 13.5, “The calculators inside the control units are usually microcontrollers. . . .  <i>The memory devices for program and data are usually EPROMS.</i> Their storage capacity is, in present applications, up to 64 Kbytes. Future applications will necessitate storage sizes up to 128 Kbytes. The failure storages for diagnostics and the storage for adaptive data are in conventional applications, battery voltage-supplied RAMs. These are increasingly being replaced by EEPROMs.”</p> <p>E.g., page 12.9, “A subsystem of the fuel control system is lambda closed-loop control. . . .</p> <p>[T]he engine control unit uses an anticipatory control strategy that uses engine load and RPM to</p>	<p>E.g., col. 2, lines 37 to 42, “The microcomputer 5 further comprises an input/output port (I/O port) 6, a central processing unit (CPU) 7, a <i>read only memory (ROM) 8, and a random access memory (RAM) 9.</i> In the microcomputer 5, there is provided a bus BUS which communicates the I/O port 6 and the CPU 7, <i>ROM 8, and RAM 9.</i>”</p> <p>E.g., col. 3, lines 7 to 20, “<i>The torque data map indicative of torque curves T as shown in FIG. 2 has been stored in the ROM 8 in advance. The fuel consumption rate data map indicative of equal fuel consumption rate curves B as shown in FIG. 3 has been also stored in the ROM 8 in advance. In FIG. 2, each equal torque curve T was prepared by plotting</i></p>		

Limitation of '781 Patent Claim 25	Automotive Electronics Handbook (Jurgen)	U.S. Patent No. 4,559,599 (Toyota '599)	U.S. Patent No. 5,357,438 (Davidian)	U.S. Patent No. 4,901,701 (Chasteen)
	<p>determine the approximate fuel requirement. <i>The engine load information is provided by the manifold pressure sensor for speed density systems and by the air meter for air flow and air mass measurement systems and by the throttle valve position sensor. The engine control unit contains data tables for combinations of load and RPM.</i> This allows for rapid response to changes in operating conditions. The lambda sensor still provides the feedback correction for each load/RPM point. . . .</p> <p>E.g., pages 22.2 to 22.3, "The most important test points of control units and sensors are tied to a diagnostic connector which is plugged into the measuring instrument with a corresponding adapter for the respective vehicle. . . .</p> <p><i>Modern electronics in vehicles support diagnosis by comparing the registered actual value with the internally stored nominal values</i> with the help of control units and their self-diagnosis, thus detecting faults."</p>	<p><i>and connecting equal torque points on the graph with respect to the engine speed vs. throttle valve opening.</i> In FIG. 3, each fuel consumption rate curve B was prepared by plotting and connecting equal fuel consumption rate points on a graph obtained in advance by experiment data with respect to the engine speed and the torques thus calculated."</p>		
means for comparing engine speed to said RPM set point;	E.g., page 13.7 to 13.9, " <i>The basic functions of the transmission control are the shift point control</i> , the lockup	E.g., col. 2, lines 37 to 42, "The microcomputer 5 further comprises an input/output port (I/O port) 6, a central processing		E.g., col. 11, lines 22 to 33, " <i>As indicated at 303 the CPU determines from the reading taken at 302 whether or not the</i>

Limitation of '781 Patent Claim 25	Automotive Electronics Handbook (Jurgen)	U.S. Patent No. 4,559,599 (Toyota '599)	U.S. Patent No. 5,357,438 (Davidian)	U.S. Patent No. 4,901,701 (Chasteen)
	<p>control, engine torque control during shifting, related safety functions, and diagnostic functions for vehicle service.”</p> <p>E.g., page 13.9, “The basic shift point control uses shift maps, which are defined in data in the unit memory. These shift maps are selectable over a wide range. <i>The shift point limitations are made</i>, on the one hand, by the highest admissible engine speed for each application and, on the other hand, <i>by the lowest engine speed that is practical for driving comfort and noise emission. The inputs of the shift point determination are the throttle position, the accelerator pedal position, and the vehicle speed</i> (determined by the transmission output speed).”</p>	<p>unit (CPU) 7, a <i>read only memory (ROM) 8, and a random access memory (RAM) 9</i>. In the microcomputer 5, there is provided a bus BUS which communicates the I/O port 6 and the CPU 7, <i>ROM 8, and RAM 9</i>.”</p> <p>E.g., col. 3, lines 7 to 20, “<i>The torque data map indicative of torque curves T as shown in FIG. 2 has been stored in the ROM 8 in advance. The fuel consumption rate data map indicative of equal fuel consumption rate curves B as shown in FIG. 3 has been also stored in the ROM 8 in advance. In FIG. 2, each equal torque curve T was prepared by plotting and connecting equal torque points on the graph with respect to the engine speed vs. throttle valve opening. In FIG. 3, each fuel consumption rate curve B was prepared by plotting and connecting equal fuel consumption rate points on a graph obtained in advance by experiment data with respect to the engine speed and the torques thus calculated.</i>”</p> <p>E.g., col. 3, lines 44 to 61, “<i>In this case, as shown in FIG. 4, the operation of a main routine is started at a predetermined</i></p>		<p><i>engine RPM is greater than 0. If engine RPM is greater than 0, the CPU next makes the determination from the throttle position reading of 302 whether or not the throttle position is greater than a predetermined amount, such as 20°, as indicated in block 304. If throttle position is less than 20°, the CPU decision-making process returns to block 302. If the throttle position is greater than the predetermined amount and RPM = 0, the CPU provides a control command to the engine fuel injector(s) to prime the engine.</i>”</p>

Limitation of '781 Patent Claim 25	Automotive Electronics Handbook (Jurgen)	U.S. Patent No. 4,559,599 (Toyota '599)	U.S. Patent No. 5,357,438 (Davidian)	U.S. Patent No. 4,901,701 (Chasteen)
		<p><i>timing, e.g. periodical timing pulses from a timer (not shown) and the detection of the engine speed <math>N_e</math> from the sensor 1 is carried out and it is stored into the RAM 9 at the step 20. Then, the engine speed <math>N_e</math> is read from the RAM 9 and it is compared with a predetermined number <math>N</math> (=1000 rpm) to determine whether or not the <math>N_e</math> exceeds the value 1000 at the step 21. If the result of the decision is YES, the next step 22 is executed. That is, in the step 22, the reading in of the opening of the throttle valve is performed through the throttle sensor 3 and the A/D converter 4. In the above case, if the result of the decision in step 21 is NO, the main routine is terminated by determining that the shift operation is not necessary and the engine speed <math>N_e</math> is read again at the predetermined timing and now the operation returns to the step 20."</i></p> <p>E.g., Figure 4:</p>		

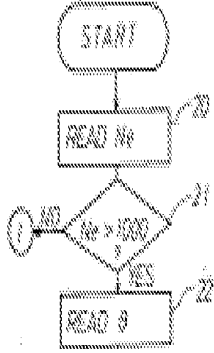
Limitation of '781 Patent Claim 25	Automotive Electronics Handbook (Jurgen)	U.S. Patent No. 4,559,599 (Toyota '599)	U.S. Patent No. 5,357,438 (Davidian)	U.S. Patent No. 4,901,701 (Chasteen)
		 <pre> graph TD     START([START]) --&gt; READ_N[READ N]     READ_N --&gt; DEC{N &gt; NMAX}     DEC -- NO --&gt; READ_N     DEC -- YES --&gt; READ_0[READ 0] </pre>		
<p>said processor subsystem activating said upshift notification circuit if both road speed and throttle position for said vehicle are increasing, manifold pressure for said vehicle is at or below said manifold pressure set point and engine speed for said vehicle is at or above said RPM set point.</p>	<p>E.g., page 13.7 to 13.9, <i>“The basic functions of the transmission control are the shift point control, the lockup control, engine torque control during shifting, related safety functions, and diagnostic functions for vehicle service.”</i>  E.g., page 13.9, <i>“The basic shift point control uses shift maps, which are defined in data in the unit memory. These shift maps are selectable over a wide range. The shift point limitations are made, on the one hand, by the highest admissible engine speed for each application and, on the other hand, by the lowest engine speed that is practical for driving comfort and noise emission. The inputs of the shift point determination are the throttle position, the accelerator pedal position, and the vehicle speed (determined by the</i></p>	<p>E.g., col. 2, lines 37 to 42, <i>“The microcomputer 5 further comprises an input/output port (I/O port) 6, a central processing unit (CPU) 7, a read only memory (ROM) 8, and a random access memory (RAM) 9. In the microcomputer 5, there is provided a bus BUS which communicates the I/O port 6 and the CPU 7, ROM 8, and RAM 9.”</i>   E.g., col. 2, lines 59 to 63, <i>“The input of the indicator 10 is connected to the output of the I/O port 6 so as to indicate each preferable shift position corresponding to the optimum fuel consumption rate in accordance with various parameters calculated.”</i>   E.g., col. 5, line 63 to col. 6, line 2, <i>“Namely, in this step, the speed change operation</i></p>		<p>E.g., col. 9, lines 1 to 8, <i>“The electronic control assembly comprises a number of sensors having sensor outputs which are provided to the CPU 130 through interface circuitry 132. These sensors may include a battery voltage sensor 134, an air temperature sensor 136, an engine temperature sensor 138, an engine speed sensor 140, an ignition timing sensor 142, a barometric pressure sensor 144, and a throttle position sensor 146.”</i>   E.g., col. 9, lines 48 to 55, <i>“The CPU 130 receives and processes the signals from the various sensors described above and generates control signals which are used to control fuel pump speed, to maintain the speed of operation of the fuel pump at a rate which provides a pressure in</i></p>



Limitation of '781 Patent Claim 25	Automotive Electronics Handbook (Jurgen)	U.S. Patent No. 4,559,599 (Toyota '599)	U.S. Patent No. 5,357,438 (Davidian)	U.S. Patent No. 4,901,701 (Chasteen)
	transmission output speed).”	<i>indicating signal is applied to the indicator or display 10 from the microcomputer 5 through the I/O port 6. As a result, a particular lamp in this case, a shift up indicating lamp in the indicator 10, is illuminated, thus indicating to the drive that the speed change from current shift position to the one step shifting up position SP<sub>+1</sub> is preferable.”</i>		<p>the circulation conduit portion immediately downstream therefrom which is approximately equal to the preset maximum pressure of the pressure regulator 114.”</p> <p>E.g., col. 11, lines 22 to 33, “As indicated at 303 the CPU determines from the reading taken at 302 whether or not the engine RPM is greater than 0. If engine RPM is greater than 0, the CPU next makes the determination from the throttle position reading of 302 whether or not the throttle position is greater than a predetermined amount, such as 20°, as indicated in block 304. If throttle position is less than 20°, the CPU decision-making process returns to block 302. If the throttle position is greater than the predetermined amount and RPM = 0, the CPU provides a control command to the engine fuel injector(s) to prime the engine.”</p> <p>E.g., August 6, 1998 Office Action, “Chasteen discloses the sensors as discussed for sensing the signals and a processor and compare manifold pressure for activating the fuel injection. Chasteen discloses the speed (RPM) and throttle position are determined to be greater than 0</p>

Limitation of '781 Patent Claim 25	Automotive Electronics Handbook (Jurgen)	U.S. Patent No. 4,559,599 (Toyota '599)	U.S. Patent No. 5,357,438 (Davidian)	U.S. Patent No. 4,901,701 (Chasteen)
				(increasing) and the CPU provides a control command to the engine fuel injector to prime the engine (See column 11, lines 22-33) therefore on [sic] would consider increasing and decreasing the speed and throttle for adjusting the fuel injector for supplying fuel to the engine."

Limitation of '781 Patent Claim 27	Automotive Electronics Handbook (Jurgen)	U.S. Patent No. 4,559,599 (Toyota '599)	U.S. Patent No. 5,357,438 (Davidian)	U.S. Patent No. 4,901,701 (Chasteen)
<p>27. Apparatus for optimizing operation of a vehicle according to claim 26 wherein said processor subsystem further comprises:</p>	<p>See claim 26 claim chart, at page A-91.</p>	<p>See claim 26 claim chart, at page A-91.</p>	<p>See claim 26 claim chart, at page A-91.</p>	<p>E.g., col. 1, lines 9 to 13, "The present invention relates generally to two-stroke operating cycle engines and, more particularly, to a two stroke engine fuel injection system and control system therefor which are adapted for extreme weather conditions."</p> <p>E.g., col. 2, lines 2 to 17, "Small, two-cycle engines are especially subject to malfunction under variable operating conditions such as changes in sea level, with associated barometric changes and changes in ambient air temperature. Many machines such as snowmobiles, snowblowers, dirt bikes, etc., are operated in such widely variable operating conditions. In view of the costs associated with engine modification for sensors' need for electronic control of fuel injectors and in view of the fact that the engine parameters which are critical to control of fuel injectors for two-cycle engines were not, prior to the present invention, understood in the art, a successful electronically-controlled fuel injection system for small, two-cycle engines which are subject to extremes in operating conditions has not been developed in the prior art."</p>

Limitation of '781 Patent Claim 27	Automotive Electronics Handbook (Jurgen)	U.S. Patent No. 4,559,599 (Toyota '599)	U.S. Patent No. 5,357,438 (Davidian)	U.S. Patent No. 4,901,701 (Chasteen)
means for determining when road speed for said vehicle is decreasing;	<p>E.g., page 7.6, "There are several applications for rotational speed sensing. First it is necessary to monitor engine speed. This information is used for transmission control, engine control, cruise control, and possibly for a tachometer. Electronics and electronic sensing in the automobile were brought about by the need for higher efficiency engines, better fuel economy, increased power and performance, and lower emissions. Second, <i>wheel speed sensing is required</i> for use in transmissions, cruise control, speedometers, antilock brake systems (ABS), traction control (ASR), variable ratio power steering assist, four-wheel steering, and possibly in inertial navigation and air bag deployment applications."</p> <p>E.g., page 7.8, "In electronic transmission applications, <i>information from the road and engine speed sensors</i>, as well as torque data and throttle position are required for the MCU to select the optimum gear ratio."</p>		E.g., col. 4, lines 60 to 66, "Vehicle 2 is further equipped with <i>a speed sensor 12 which may sense the speed of the vehicle in any known manner</i> , for example using the speed measuring system of the vehicle itself, or a speed measuring system independent of the vehicle, e.g., an acceleration sensor, or by calculations based on the Doppler effect, etc."	
means for determining when throttle position for said vehicle is increasing;	E.g., page 12.18, "To control the idle speed, the ECU uses inputs from the <i>throttle position sensor</i> , air conditioning, automatic transmission, power steering,	E.g., col. 2, lines 23 to 36, "Referring to FIG. 1, the shift indication apparatus with a manual transmission according to the present invention	E.g., col. 4, lines 60 to 66, "Vehicle 2 is further equipped with <i>a speed sensor 12 which may sense the speed of the vehicle in any known manner</i> ,	E.g., col. 9, lines 3 to 8, "These sensors may include a battery voltage sensor 134, an air temperature sensor 136, an engine temperature sensor 138,

Limitation of '781 Patent Claim 27	Automotive Electronics Handbook (Jurgen)	U.S. Patent No. 4,559,599 (Toyota '599)	U.S. Patent No. 5,357,438 (Davidian)	U.S. Patent No. 4,901,701 (Chasteen)
	<p>charging system, engine RPM, and vehicle speed.”</p> <p>E.g., page 12.21, “The electronic injection unit also houses the <i>throttle position sensor</i> and, in some cases, an inlet air temperature sensor which provides operating condition information to the ECU.”</p>	<p>comprises an engine speed sensor 1 for detecting the engine speed and for producing pulse signals of a frequency proportional to the engine speed, a shift position sensor 2 for detecting the shift positions of the transmission, <i>a throttle sensor 3 for detecting the opening degree of the throttle valve by means of, for instance, a potentiometer</i>, an A/D converter 4 for converting analog signals from the throttle valve sensor 3 into digital signals, a microcomputer 5 for performing various calculations in accordance with the different signals from the sensors, and an indicator 10 for indicating the result of the calculations.”</p> <p>E.g., col. 2, lines 52 to 59, “Similarly, the output of <i>the throttle sensor 3</i> is connected through the A/D converter 4 to the input of the I/O port 6 so as to transmit the output signals thereof to the microcomputer 5 through the A/D converter 4 and to store the data corresponding to the throttle value opening into the RAM 9 after converting from the analog signals into the digital signals.”</p> <p>E.g., FIG. 1:</p>	<p>for example using the speed measuring system of the vehicle itself, or a speed measuring system independent of the vehicle, e.g., an acceleration sensor, or by calculations based on the Doppler effect, etc.”</p>	<p>an engine speed sensor 140, an ignition timing sensor 142, a barometric pressure sensor 144, and <i>a throttle position sensor 146</i>.”</p> <p>E.g., FIG. 1</p>

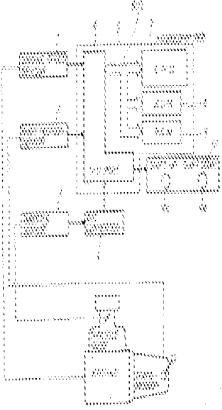
Limitation of '781 Patent Claim 27	Automotive Electronics Handbook (Jurgen)	U.S. Patent No. 4,559,599 (Toyota '599)	U.S. Patent No. 5,357,438 (Davidian)	U.S. Patent No. 4,901,701 (Chasteen)
				
<p>means for determining when manifold pressure for said vehicle is increasing; and</p>	<p>E.g., page 2.5, “Automotive specification and testing guidelines have been developed and published by the Society of Automotive Engineers (SAE) specifically for <i>manifold absolute pressure (MAP) sensors</i>.”</p> <p>E.g., page 2.7, “Manifold absolute pressure (MAP) is used as an input to fuel and ignition control in internal combustion engine control systems. <i>The speed-density system that uses the MAP sensor</i> has been preferred over mass air flow (MAF) control because it's less expensive, but stricter emission standards are causing more manufacturers to use mass air flow for future models.”</p>			
<p>means for determining when engine speed for said vehicle is</p>	<p>E.g., page 7.6, “There are several applications for rotational speed</p>	<p>E.g., col. 2, lines 23 to 36, “Referring to FIG. 1, the shift</p>		<p>E.g., col. 9, lines 3 to 8, “These sensors may include a battery</p>

Limitation of '781 Patent Claim 27	Automotive Electronics Handbook (Jurgen)	U.S. Patent No. 4,559,599 (Toyota '599)	U.S. Patent No. 5,357,438 (Davidian)	U.S. Patent No. 4,901,701 (Chasteen)
decreasing;	<p>sensing. <i>First it is necessary to monitor engine speed.</i> This information is used for transmission control, engine control, cruise control, and possibly for a tachometer. Electronics and electronic sensing in the automobile were brought about by the need for higher efficiency engines, better fuel economy, increased power and performance, and lower emissions. Second, wheel speed sensing is required for use in transmissions, cruise control, speedometers, antilock brake systems (ABS), traction control (ASR), variable ratio power steering assist, four-wheel steering, and possibly in inertial navigation and air bag deployment applications.”</p> <p>E.g., page 7.8, “In electronic transmission applications, <i>information from the road and engine speed sensors</i>, as well as torque data and throttle position are required for the MCU to select the optimum gear ratio.”</p>	<p>indication apparatus with a manual transmission according to the present invention comprises <i>an engine speed sensor 1 for detecting the engine speed and for producing pulse signals of a frequency proportional to the engine speed</i>, a shift position sensor 2 for detecting the shift positions of the transmission, <i>a throttle sensor 3 for detecting the opening degree of the throttle valve by means of, for instance, a potentiometer</i>, an A/D converter 4 for converting analog signals from the throttle valve sensor 3 into digital signals, a microcomputer 5 for performing various calculations in accordance with the different signals from the sensors, and an indicator 10 for indicating the result of the calculations.”</p> <p>E.g., col. 2, lines 43 to 48, “<i>The engine speed sensor 1</i> is mounted in a distributor (not shown) and the output of the sensor is connected to the input of the I/O port 6 so as to transmit the output pulses to the microcomputer 5 through the I/O port 6 and to store the data corresponding to the engine speed into the RAM 9.”</p> <p>E.g., FIG. 1:</p>		<p>voltage sensor 134, an air temperature sensor 136, an engine temperature sensor 138, <i>an engine speed sensor 140</i>, an ignition timing sensor 142, a barometric pressure sensor 144, and a throttle position sensor 146.”</p> <p>E.g., FIG. 1</p>

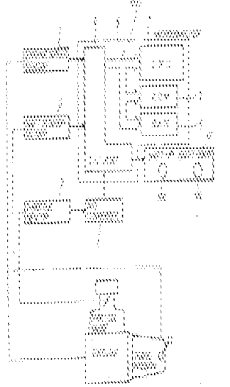
Limitation of '781 Patent Claim 27	Automotive Electronics Handbook (Jurgen)	U.S. Patent No. 4,559,599 (Toyota '599)	U.S. Patent No. 5,357,438 (Davidian)	U.S. Patent No. 4,901,701 (Chasteen)
				
<p>said processor subsystem activating said downshift notification circuit if both road speed and engine speed are decreasing and both throttle position and manifold pressure for said vehicle are increasing.</p>	<p>E.g., page 13.7 to 13.9, "<b>The basic functions of the transmission control are the shift point control</b>, the lockup control, engine torque control during shifting, related safety functions, and diagnostic functions for vehicle service." E.g., page 13.9, "The basic shift point control uses shift maps, which are defined in data in the unit memory. These shift maps are selectable over a wide range. <b>The shift point limitations are made</b>, on the one hand, by the highest admissible engine speed for each application and, on the other hand, <b>by the lowest engine speed that is practical for driving comfort and noise emission. The inputs of the shift point determination are the throttle position, the accelerator pedal position, and the vehicle speed</b> (determined by the transmission output speed)."</p>	<p>E.g., col. 2, lines 37 to 42, "<b>The microcomputer 5 further comprises an input/output port (I/O port) 6, a central processing unit (CPU) 7, a read only memory (ROM) 8, and a random access memory (RAM) 9.</b> In the microcomputer 5, there is provided a bus BUS which communicates the I/O port 6 and the CPU 7, ROM 8, and RAM 9." E.g., col. 2, lines 59 to 63, "<b>The input of the indicator 10 is connected to the output of the I/O port 6 so as to indicate each preferable shift position corresponding to the optimum fuel consumption rate in accordance with various parameters calculated.</b>" E.g., col. 5, line 63 to col. 6, line 2, "<b>Namely, in this step, the speed change operation</b></p>		<p>E.g., col. 9, lines 1 to 8, "The electronic control assembly comprises a number of sensors having sensor outputs which are provided to the CPU 130 through interface circuitry 132. These sensors may include a battery voltage sensor 134, an air temperature sensor 136, an engine temperature sensor 138, an engine speed sensor 140, an ignition timing sensor 142, a barometric pressure sensor 144, and a throttle position sensor 146." E.g., col. 9, lines 48 to 55, "The CPU 130 receives and processes the signals from the various sensors described above and generates control signals which are used to control fuel pump speed, to maintain the speed of operation of the fuel pump at a rate which provides a pressure in the circulation conduit portion</p>



Limitation of '781 Patent Claim 27	Automotive Electronics Handbook (Jurgen)	U.S. Patent No. 4,559,599 (Toyota '599)	U.S. Patent No. 5,357,438 (Davidian)	U.S. Patent No. 4,901,701 (Chasteen)
		<p><i>indicating signal is applied to the indicator or display 10 from the microcomputer 5 through the I/O port 6. As a result, a particular lamp in this case, a shift up indicating lamp in the indicator 10, is illuminated, thus indicating to the drive that the speed change from current shift position to the one step shifting up position SP<sub>+</sub> is preferable.”</i></p> <p>E.g., col. 2, line 64 to col. 3, line 3, “<i>The indicator 10 includes a shift-up indicating lamp 10a and a shift-down indicating lamp 10b.</i></p> <p><i>The indicator 10 may be assembled by light emitting [sic] diodes (LED) so as to perform shift-up and shift-down indications by up and down directed arrow marks.</i></p> <p>Alternatively, the indicator 10 may also be replaced with other voice combining circuit so as to announce the shift operations by voice instead of the indications.”</p> <p>E.g., col. 7, lines 10 to 17, “<i>In this step 42, shift-down display is performed. Namely in this case, the shift down display instruction signal from the microcomputer 5 is applied to the indicator 10 through the I/O port 6 and the shift-down</i></p>		<p>immediately downstream therefrom which is approximately equal to the preset maximum pressure of the pressure regulator 114.”</p> <p>E.g., col. 11, lines 22 to 33, “As indicated at 303 the CPU determines from the reading taken at 302 whether or not the engine RPM is greater than 0. If engine RPM is greater than 0, the CPU next makes the determination from the throttle position reading of 302 whether or not the throttle position is greater than a predetermined amount, such as 20°, as indicated in block 304. If throttle position is less than 20°, the CPU decision-making process returns to block 302. If the throttle position is greater than the predetermined amount and RPM = 0, the CPU provides a control command to the engine fuel injector(s) to prime the engine.”</p> <p>E.g., August 6, 1998 Office Action, “Chasteen discloses the sensors as discussed for sensing the signals and a processor and compare manifold pressure for activating the fuel injection. Chasteen discloses the speed (RPM) and throttle position are determined to be greater than 0 (increasing) and the CPU</p>

Limitation of '781 Patent Claim 27	Automotive Electronics Handbook (Jurgen)	U.S. Patent No. 4,559,599 (Toyota '599)	U.S. Patent No. 5,357,438 (Davidian)	U.S. Patent No. 4,901,701 (Chasteen)
		<p><i>indication lamp in the indicator 10 is illuminated, thus indicating to the driver that speed change operation from the current shift position to the one step shifting down position SP<sub>-1</sub> is preferable.”</i></p> <p>E.g. col. 7, lines 29 to 38,  “However, <i>only when either one of the assumed fuel consumption rates above is better than the current fuel consumption rate B<sub>0</sub>, the corresponding shift-up lamp or shift-down lamp in the indicator 10 is illuminated, thus indicating the necessity of the speed change operation.”</i></p>		<p>provides a control command to the engine fuel injector to prime the engine (See column 11, lines 22-33) therefore on [sic] would consider increasing and decreasing the speed and throttle for adjusting the fuel injector for supplying fuel to the engine.”</p>

20. Claims 24, 25, and 27 are Obvious in View of the Combination of Jurgen, Volkswagen '070, Davidian, and Chasteen

Limitation of '781 Patent Claim 24	Automotive Electronics Handbook (Jurgen)	German Patent Application Publication No. 29 26 070 (Volkswagen '070)	U.S. Patent No. 5,357,438 (Davidian)	U.S. Patent No. 4,901,701 (Chasteen)
<p>24. Apparatus for optimizing operation of a vehicle according to claim 23 wherein said processor subsystem further comprises:</p>	<p>See claim 23 claim chart, at page A-126.</p>	<p>See claim 23 claim chart, at page A-126.</p>	<p>See claim 23 claim chart, at page A-126.</p>	<p>E.g., col. 1, lines 9 to 13, "The present invention relates generally to two-stroke operating cycle engines and, more particularly, to a two stroke engine fuel injection system and control system therefor which are adapted for extreme weather conditions."</p> <p>E.g., col. 2, lines 2 to 17, "Small, two-cycle engines are especially subject to malfunction under variable operating conditions such as changes in sea level, with associated barometric changes and changes in ambient air temperature. Many machines such as snowmobiles, snowblowers, dirt bikes, etc., are operated in such widely variable operating conditions. In view of the costs associated with engine modification for sensors' need for electronic control of fuel injectors and in view of the fact that the engine parameters which are critical to control of fuel injectors for two-cycle engines were not, prior to the present invention, understood in the art, a successful electronically-controlled fuel injection system for small, two-cycle engines which are subject to extremes in</p>

Limitation of '781 Patent Claim 24	Automotive Electronics Handbook (Jurgen)	German Patent Application Publication No. 29 26 070 (Volkswagen '070)	U.S. Patent No. 5,357,438 (Davidian)	U.S. Patent No. 4,901,701 (Chasteen)
				operating conditions has not been developed in the prior art.”
means for determining when road speed for said vehicle is increasing or decreasing;	<p>E.g., page 7.6, “There are several applications for rotational speed sensing. First it is necessary to monitor engine speed. This information is used for transmission control, engine control, cruise control, and possibly for a tachometer. Electronics and electronic sensing in the automobile were brought about by the need for higher efficiency engines, better fuel economy, increased power and performance, and lower emissions. Second, <i>wheel speed sensing is required</i> for use in transmissions, cruise control, speedometers, antilock brake systems (ABS), traction control (ASR), variable ratio power steering assist, four-wheel steering, and possibly in inertial navigation and air bag deployment applications.”</p> <p>E.g., page 7.8, “In electronic transmission applications, <i>information from the road and engine speed sensors</i>, as well as torque data and throttle position are required for the MCU to select the optimum gear ratio.”</p>		E.g., col. 4, lines 60 to 66, “Vehicle 2 is further equipped with <i>a speed sensor 12 which may sense the speed of the vehicle in any known manner</i> , for example using the speed measuring system of the vehicle itself, or a speed measuring system independent of the vehicle, e.g., an acceleration sensor, or by calculations based on the Doppler effect, etc.”	
means for determining when	E.g., page 12.18, “To control the	E.g., page 6 (English	E.g., col. 4, lines 60 to 66,	E.g., col. 9, lines 3 to 8, “These

Limitation of '781 Patent Claim 24	Automotive Electronics Handbook (Jurgen)	German Patent Application Publication No. 29 26 070 (Volkswagen '070)	U.S. Patent No. 5,357,438 (Davidian)	U.S. Patent No. 4,901,701 (Chasteen)
throttle position for said vehicle is increasing or decreasing; and.	<p>idle speed, the ECU uses inputs from the <i>throttle position sensor</i>, air conditioning, automatic transmission, power steering, charging system, engine RPM, and vehicle speed.”</p> <p>E.g., page 12.21, “The electronic injection unit also houses the <i>throttle position sensor</i> and, in some cases, an inlet air temperature sensor which provides operating condition information to the ECU.”</p>	<p>translation), “As can be seen when viewing Figure 1 to begin with, output N of the engine has been plotted across engine speed n. a is the curve of the output at full load, b is a line that represents a constant setting of the output control element, i.e., a line that represents a constant <i>throttle valve angle</i> in a carburetor engine.”</p>	<p>“Vehicle 2 is further equipped with a <i>speed sensor 12 which may sense the speed of the vehicle in any known manner</i>, for example using the speed measuring system of the vehicle itself, or a speed measuring system independent of the vehicle, e.g., an acceleration sensor, or by calculations based on the Doppler effect, etc.”</p>	<p>sensors may include a battery voltage sensor 134, an air temperature sensor 136, an engine temperature sensor 138, an engine speed sensor 140, an ignition timing sensor 142, a barometric pressure sensor 144, and a <i>throttle position sensor 146</i>.”</p> <p>E.g., FIG. 1</p>
means for comparing manifold pressure to said manifold pressure set point;	<p>E.g., page 13.5, “The calculators inside the control units are usually microcontrollers. . . . <i>The memory devices for program and data are usually EPROMS</i>. Their storage capacity is, in present applications, up to 64 Kbytes. Future applications will necessitate storage sizes up to 128 Kbytes. The failure storages for diagnostics and the storage for adaptive data are in conventional applications, battery voltage-supplied RAMs. These are increasingly being replaced by EEPROMs.”</p> <p>E.g., page 12.9, “A subsystem of the fuel control system is lambda closed-loop control. . . .</p> <p>[T]he engine control unit uses an</p>	<p>E.g., page 6 (English translation), “As can be seen when viewing Figure 1 to begin with, output N of the engine has been plotted across engine speed n. a is the curve of the output at full load, b is a line that represents a constant setting of the output control element, i.e., a line that represents a constant throttle valve angle in a carburetor engine. As a measure thereof, in addition to the throttle valve angle itself, it is also possible to use the <i>induction manifold vacuum</i>.”</p> <p>E.g., page 9 (English translation), “It is useful if in addition to this device, a display of the route-specific fuel</p>		

Limitation of '781 Patent Claim 24	Automotive Electronics Handbook (Jurgen)	German Patent Application Publication No. 29 26 070 (Volkswagen '070)	U.S. Patent No. 5,357,438 (Davidian)	U.S. Patent No. 4,901,701 (Chasteen)
	<p>anticipatory control strategy that uses engine load and RPM to determine the approximate fuel requirement. <i>The engine load information is provided by the manifold pressure sensor for speed density systems and by the air meter for air flow and air mass measurement systems and by the throttle valve position sensor. The engine control unit contains data tables for combinations of load and RPM.</i> This allows for rapid response to changes in operating conditions. The lambda sensor still provides the feedback correction for each load/RPM point. . . .</p> <p>E.g., pages 22.2 to 22.3, "The most important test points of control units and sensors are tied to a diagnostic connector which is plugged into the measuring instrument with a corresponding adapter for the respective vehicle. . . .</p> <p><i>Modern electronics in vehicles support diagnosis by comparing the registered actual value with the internally stored nominal values</i> with the help of control units and their self-diagnosis, thus detecting faults."</p>	<p>consumption is provided in a vehicle. Such display devices are known per se; they generally utilize the <i>injection manifold vacuum</i> as a measure of fuel consumption."</p>		
means for determining when manifold pressure for said	E.g., page 2.5, "Automotive specification and testing	E.g., page 6 (English translation), "As can be seen		

Limitation of '781 Patent Claim 24	Automotive Electronics Handbook (Jurgen)	German Patent Application Publication No. 29 26 070 (Volkswagen '070)	U.S. Patent No. 5,357,438 (Davidian)	U.S. Patent No. 4,901,701 (Chasteen)
<p>vehicle is increasing or decreasing; and</p>	<p>guidelines have been developed and published by the Society of Automotive Engineers (SAE) specifically for <i>manifold absolute pressure (MAP) sensors</i>.”</p> <p>E.g., page 2.7, “Manifold absolute pressure (MAP) is used as an input to fuel and ignition control in internal combustion engine control systems. <i>The speed-density system that uses the MAP sensor</i> has been preferred over mass air flow (MAF) control because it's less expensive, but stricter emission standards are causing more manufacturers to use mass air flow for future models.”</p>	<p>when viewing Figure 1 to begin with, output N of the engine has been plotted across engine speed n. a is the curve of the output at full load, b is a line that represents a constant setting of the output control element, i.e., a line that represents a constant throttle valve angle in a carburetor engine. As a measure thereof, in addition to the throttle valve angle itself, it is also possible to use the <i>induction manifold vacuum</i>.”</p> <p>E.g., page 9 (English translation), “It is useful if in addition to this device, a display of the route-specific fuel consumption is provided in a vehicle. Such display devices are known per se; they generally utilize the <i>injection manifold vacuum</i> as a measure of fuel consumption.”</p>		
<p>means for determining when engine speed for said vehicle is increasing or decreasing;</p>	<p>E.g., page 7.6, “There are several applications for rotational speed sensing. First it is necessary to monitor engine speed. This information is used for transmission control, engine control, cruise control, and possibly for a tachometer. Electronics and electronic sensing in the automobile were</p>	<p>E.g., page 6 (English translation), “The operating ranges I and II are further delimited by <i>engine speed</i> values <math>n_1</math> or <math>n_2</math>, the first of which usually lies between approximately 20 to 50% of the maximum engine speed, and the second usually lies between approximately 40 and 70% of the</p>		<p>E.g., col. 9, lines 3 to 8, “These sensors may include a battery voltage sensor 134, an air temperature sensor 136, an engine temperature sensor 138, <i>an engine speed sensor 140</i>, an ignition timing sensor 142, a barometric pressure sensor 144, and a throttle position sensor 146.”</p>

Limitation of '781 Patent Claim 24	Automotive Electronics Handbook (Jurgen)	German Patent Application Publication No. 29 26 070 (Volkswagen '070)	U.S. Patent No. 5,357,438 (Davidian)	U.S. Patent No. 4,901,701 (Chasteen)
	<p>brought about by the need for higher efficiency engines, better fuel economy, increased power and performance, and lower emissions. Second, <i>wheel speed sensing is required</i> for use in transmissions, cruise control, speedometers, antilock brake systems (ABS), traction control (ASR), variable ratio power steering assist, four-wheel steering, and possibly in inertial navigation and air bag deployment applications.”</p> <p>E.g., page 7.8, “In electronic transmission applications, <i>information from the road and engine speed sensors</i>, as well as torque data and throttle position are required for the MCU to select the optimum gear ratio.”</p>	<p>maximum engine speed.”</p> <p>E.g., page 8 (English translation), “<i>The engine speed signal is obtained with the aid of known sensor systems</i>, which therefore need not be described in further detail here.”</p>		<p>E.g., FIG. 1</p>
<p>said processor subsystem activating said fuel overinjection notification circuit if both road speed and throttle position for said vehicle are increasing and manifold pressure for said vehicle is above said manifold pressure set point or if both throttle position and manifold pressure for said vehicle are increasing and road speed and engine speed for said vehicle are</p>	<p>E.g., page 12.4, “During coasting and braking, fuel consumption can be further reduced by shutting off the fuel until the engine speed decreases to slightly higher than the set idle speed. <i>The ECU determines when fuel shutoff can occur by evaluating the throttle position, engine RPM, and vehicle speed.</i>”</p>	<p>E.g., page 9 (English translation), “It is useful if in addition to this device, <i>a display of the route-specific fuel consumption is provided in a vehicle.</i> Such display devices are known per se; they generally utilize the injection manifold vacuum as a measure of fuel consumption.”</p>		<p>E.g., col. 9, lines 1 to 8, “The electronic control assembly comprises a number of sensors having sensor outputs which are provided to the CPU 130 through interface circuitry 132. These sensors may include a battery voltage sensor 134, an air temperature sensor 136, an engine temperature sensor 138, an engine speed sensor 140, an ignition timing sensor 142, a</p>



Limitation of '781 Patent Claim 24	Automotive Electronics Handbook (Jurgen)	German Patent Application Publication No. 29 26 070 (Volkswagen '070)	U.S. Patent No. 5,357,438 (Davidian)	U.S. Patent No. 4,901,701 (Chasteen)
decreasing.	E.g., page 12.14, "Using the inputs of engine RPM and vehicle speed to the electronic control unit, thresholds can be established for limiting these variables with fuel cutoff. <i>When the maximum speed is achieved, the fuel injectors are shut off.</i> When the speed decreases below the threshold, fuel injection resumes."			<p>barometric pressure sensor 144, and a throttle position sensor 146."</p> <p>E.g., col. 9, lines 48 to 55, "The CPU 130 receives and processes the signals from the various sensors described above and generates control signals which are used to control fuel pump speed, to maintain the speed of operation of the fuel pump at a rate which provides a pressure in the circulation conduit portion immediately downstream therefrom which is approximately equal to the preset maximum pressure of the pressure regulator 114."</p> <p>E.g., col. 11, lines 22 to 33, "As indicated at 303 the CPU determines from the reading taken at 302 whether or not the engine RPM is greater than 0. If engine RPM is greater than 0, the CPU next makes the determination from the throttle position reading of 302 whether or not the throttle position is greater than a predetermined amount, such as 20°, as indicated in block 304. If throttle position is less than 20°, the CPU decision-making process returns to block 302. If the throttle position is greater than the</p>

Limitation of '781 Patent Claim 24	Automotive Electronics Handbook (Jurgen)	German Patent Application Publication No. 29 26 070 (Volkswagen '070)	U.S. Patent No. 5,357,438 (Davidian)	U.S. Patent No. 4,901,701 (Chasteen)
				<p>predetermined amount and RPM = 0, the CPU provides a control command to the engine fuel injector(s) to prime the engine.”</p> <p>E.g., August 6, 1998 Office Action, “Chasteen discloses the sensors as discussed for sensing the signals and a processor and compare manifold pressure for activating the fuel injection. Chasteen discloses the speed (RPM) and throttle position are determined to be greater than 0 (increasing) and the CPU provides a control command to the engine fuel injector to prime the engine (See column 11, lines 22-33) therefore on [sic] would consider increasing and decreasing the speed and throttle for adjusting the fuel injector for supplying fuel to the engine.”</p>

Limitation of '781 Patent Claim 25	Automotive Electronics Handbook (Jurgen)	German Patent Application Publication No. 29 26 070 (Volkswagen '070)	U.S. Patent No. 5,357,438 (Davidian)	U.S. Patent No. 4,901,701 (Chasteen)
<p>25. Apparatus for optimizing operation of a vehicle according to claim 23 wherein said processor subsystem further comprises:</p>	<p>See claim 23 claim chart, at page A-126.</p>	<p>See claim 23 claim chart, at page A-126.</p>	<p>See claim 23 claim chart, at page A-126.</p>	<p>E.g., col. 1, lines 9 to 13, "The present invention relates generally to two-stroke operating cycle engines and, more particularly, to a two stroke engine fuel injection system and control system therefor which are adapted for extreme weather conditions."</p> <p>E.g., col. 2, lines 2 to 17, "Small, two-cycle engines are especially subject to malfunction under variable operating conditions such as changes in sea level, with associated barometric changes and changes in ambient air temperature. Many machines such as snowmobiles, snowblowers, dirt bikes, etc., are operated in such widely variable operating conditions. In view of the costs associated with engine modification for sensors' need for electronic control of fuel injectors and in view of the fact that the engine parameters which are critical to control of fuel injectors for two-cycle engines were not, prior to the present invention, understood in the art, a successful electronically-controlled fuel injection system for small, two-cycle engines which are subject to extremes</p>

Limitation of '781 Patent Claim 25	Automotive Electronics Handbook (Jurgen)	German Patent Application Publication No. 29 26 070 (Volkswagen '070)	U.S. Patent No. 5,357,438 (Davidian)	U.S. Patent No. 4,901,701 (Chasteen)
				in operating conditions has not been developed in the prior art."
means for determining when road speed for said vehicle is increasing;	<p>E.g., page 7.6, "There are several applications for rotational speed sensing. First it is necessary to monitor engine speed. This information is used for transmission control, engine control, cruise control, and possibly for a tachometer. Electronics and electronic sensing in the automobile were brought about by the need for higher efficiency engines, better fuel economy, increased power and performance, and lower emissions. Second, <i>wheel speed sensing is required</i> for use in transmissions, cruise control, speedometers, antilock brake systems (ABS), traction control (ASR), variable ratio power steering assist, four-wheel steering, and possibly in inertial navigation and air bag deployment applications."</p> <p>E.g., page 7.8, "In electronic transmission applications, <i>information from the road and engine speed sensors</i>, as well as torque data and throttle position are required for the MCU to select the optimum gear ratio."</p>		E.g., col. 4, lines 60 to 66, "Vehicle 2 is further equipped with <i>a speed sensor 12 which may sense the speed of the vehicle in any known manner</i> , for example using the speed measuring system of the vehicle itself, or a speed measuring system independent of the vehicle, e.g., an acceleration sensor, or by calculations based on the Doppler effect, etc."	

Limitation of '781 Patent Claim 25	Automotive Electronics Handbook (Jurgen)	German Patent Application Publication No. 29 26 070 (Volkswagen '070)	U.S. Patent No. 5,357,438 (Davidian)	U.S. Patent No. 4,901,701 (Chasteen)
means for determining when throttle position for said vehicle is increasing;	<p>E.g., page 12.18, "To control the idle speed, the ECU uses inputs from the <i>throttle position sensor</i>, air conditioning, automatic transmission, power steering, charging system, engine RPM, and vehicle speed."</p> <p>E.g., page 12.21, "The electronic injection unit also houses the <i>throttle position sensor</i> and, in some cases, an inlet air temperature sensor which provides operating condition information to the ECU."</p>	<p>E.g., page 6 (English translation), "As can be seen when viewing Figure 1 to begin with, output N of the engine has been plotted across engine speed n. a is the curve of the output at full load, b is a line that represents a constant setting of the output control element, i.e., a line that represents a constant <i>throttle valve angle</i> in a carburetor engine."</p>	<p>E.g., col. 4, lines 60 to 66, "Vehicle 2 is further equipped with <i>a speed sensor 12 which may sense the speed of the vehicle in any known manner</i>, for example using the speed measuring system of the vehicle itself, or a speed measuring system independent of the vehicle, e.g., an acceleration sensor, or by calculations based on the Doppler effect, etc."</p>	<p>E.g., col. 9, lines 3 to 8, "These sensors may include a battery voltage sensor 134, an air temperature sensor 136, an engine temperature sensor 138, an engine speed sensor 140, an ignition timing sensor 142, a barometric pressure sensor 144, and <i>a throttle position sensor 146</i>."</p> <p>E.g., FIG. 1</p>
means for comparing manifold pressure to said manifold pressure set point; and	<p>E.g., page 13.5, "The calculators inside the control units are usually microcontrollers. . . . <i>The memory devices for program and data are usually EPROMS</i>. Their storage capacity is, in present applications, up to 64 Kbytes. Future applications will necessitate storage sizes up to 128 Kbytes. The failure storages for diagnostics and the storage for adaptive data are in conventional applications, battery voltage-supplied RAMs. These are increasingly being replaced by EEPROMs."</p>	<p>E.g., page 6 (English translation), "As can be seen when viewing Figure 1 to begin with, output N of the engine has been plotted across engine speed n. a is the curve of the output at full load, b is a line that represents a constant setting of the output control element, i.e., a line that represents a constant throttle valve angle in a carburetor engine. As a measure thereof, in addition to the throttle valve angle itself, it is also possible to use the <i>induction manifold vacuum</i>."</p> <p>E.g., page 9 (English translation), "It is useful if in addition to this device, a display of the route-specific fuel consumption is provided in a vehicle."</p>		

Limitation of '781 Patent Claim 25	Automotive Electronics Handbook (Jurgen)	German Patent Application Publication No. 29 26 070 (Volkswagen '070)	U.S. Patent No. 5,357,438 (Davidian)	U.S. Patent No. 4,901,701 (Chasteen)
	<p>E.g., page 12.9, "A subsystem of the fuel control system is lambda closed-loop control. . . .</p> <p>[T]he engine control unit uses an anticipatory control strategy that uses engine load and RPM to determine the approximate fuel requirement. <i>The engine load information is provided by the manifold pressure sensor for speed density systems and by the air meter for air flow and air mass measurement systems and by the throttle valve position sensor. The engine control unit contains data tables for combinations of load and RPM.</i> This allows for rapid response to changes in operating conditions. The lambda sensor still provides the feedback correction for each load/RPM point. . . .</p> <p>E.g., pages 22.2 to 22.3, "The most important test points of control units and sensors are tied to a diagnostic connector which is plugged into the measuring instrument with a corresponding adapter for the respective vehicle. . . . <i>Modern electronics in vehicles support diagnosis by</i></p>	<p>Such display devices are known per se; they generally utilize the <i>injection manifold vacuum</i> as a measure of fuel consumption."</p>		

Limitation of '781 Patent Claim 25	Automotive Electronics Handbook (Jurgen)	German Patent Application Publication No. 29 26 070 (Volkswagen '070)	U.S. Patent No. 5,357,438 (Davidian)	U.S. Patent No. 4,901,701 (Chasteen)
	<p><i>comparing the registered actual value with the internally stored nominal values with the help of control units and their self-diagnosis, thus detecting faults.</i></p>			
<p>means for comparing engine speed to said RPM set point;</p>	<p>E.g., page 13.7 to 13.9, "<b>The basic functions of the transmission control are the shift point control</b>, the lockup control, engine torque control during shifting, related safety functions, and diagnostic functions for vehicle service."</p> <p>E.g., page 13.9, "The basic shift point control uses shift maps, which are defined in data in the unit memory. These shift maps are selectable over a wide range. <b>The shift point limitations are made</b>, on the one hand, by the highest admissible engine speed for each application and, on the other hand, <b>by the lowest engine speed that is practical for driving comfort and noise emission. The inputs of the shift point determination are the throttle position, the accelerator pedal position, and the vehicle speed</b> (determined by the transmission output speed)."</p>	<p>E.g., pages 6 to 7 (English translation), "Looking initially at operating range I remote from full load, <b>the desired output at a lower specific fuel consumption is able to be achieved after upshifting into the next higher gear</b>, at an operating point that lies to the left of operating range I in the diagram of Figure 1. <b>Accordingly, the device of the present invention generates a signal that asks the operator, i.e., normally the driver, to shift to a higher gear, which is indicated in Figure 1 by the upward pointing arrow within operating range I.</b>"</p> <p>E.g., pages 7 to 8 (English translation), "The two control circuits 2 and 3 are selectively closed by engine-speed dependent change-over switch 6, to which a signal that corresponds to the individual engine speed <math>n</math> is forwarded and which is developed in such a way that <b>at engine speeds that are greater than predefined engine speed <math>n_1</math> (see Figure 1), its shift lever pivots upwardly in Figure 2, but at engine speeds that are smaller than</b></p>		<p>E.g., col. 11, lines 22 to 33, "<b>As indicated at 303 the CPU determines from the reading taken at 302 whether or not the engine RPM is greater than 0</b>. If engine RPM is greater than 0, the CPU next makes the determination from the throttle position reading of 302 whether or not the throttle position is greater than a predetermined amount, such as 20°, as indicated in block 304. If throttle position is less than 20°, the CPU decision-making process returns to block 302. <b>If the throttle position is greater than the predetermined amount and RPM = 0, the CPU provides a control command to the engine fuel injector(s) to prime the engine.</b>"</p>

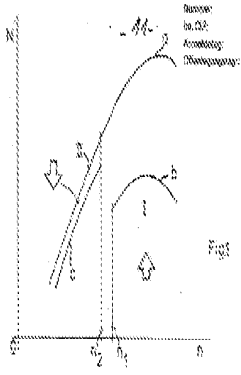
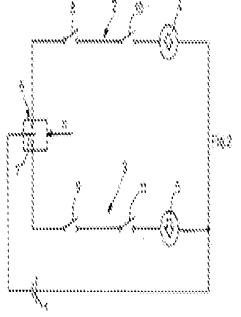
Limitation of '781 Patent Claim 25	Automotive Electronics Handbook (Jurgen)	German Patent Application Publication No. 29 26 070 (Volkswagen '070)	U.S. Patent No. 5,357,438 (Davidian)	U.S. Patent No. 4,901,701 (Chasteen)
		<p><i>predefined engine speed <math>n_2</math>, it pivots in the downward direction from a neutral center position, which it therefore assumes when engine speed values between <math>n_1</math> and <math>n_2</math> are present."</i></p> <p>E.g., Figure 1:</p>  <p>E.g., Figure 2:</p> 		
<p>said processor subsystem activating said upshift notification circuit if both road speed and throttle position for said vehicle are increasing, manifold pressure for said</p>	<p>E.g., page 13.7 to 13.9, "<i>The basic functions of the shift point control</i>, the lockup control, engine torque control during shifting, related safety</p>	<p>E.g., pages 6 to 7 (English translation), "Looking initially at operating range I remote from full load, <i>the desired output at a lower specific fuel consumption is able to be achieved after upshifting into the</i></p>		<p>E.g., col. 9, lines 1 to 8, "The electronic control assembly comprises a number of sensors having sensor outputs which are provided to the CPU 130 through interface circuitry 132.</p>

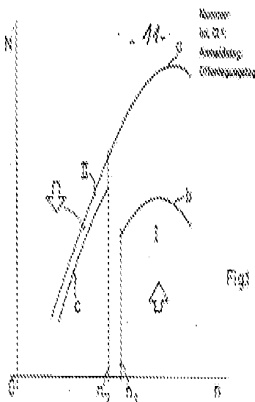
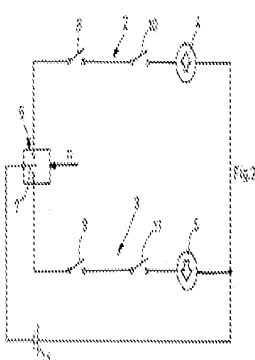

Limitation of '781 Patent Claim 25	Automotive Electronics Handbook (Jurgen)	German Patent Application Publication No. 29 26 070 (Volkswagen '070)	U.S. Patent No. 5,357,438 (Davidian)	U.S. Patent No. 4,901,701 (Chasteen)
<p>vehicle is at or below said manifold pressure set point and engine speed for said vehicle is at or above said RPM set point.</p>	<p>functions, and diagnostic functions for vehicle service.” E.g., page 13.9, “The basic shift point control uses shift maps, which are defined in data in the unit memory. These shift maps are selectable over a wide range. <b>The shift point limitations are made</b>, on the one hand, by the highest admissible engine speed for each application and, on the other hand, <b>by the lowest engine speed that is practical for driving comfort and noise emission. The inputs of the shift point determination are the throttle position, the accelerator pedal position, and the vehicle speed</b> (determined by the transmission output speed).”</p>	<p><i>next higher gear</i>, at an operating point that lies to the left of operating range I in the diagram of Figure 1. <b>Accordingly, the device of the present invention generates a signal that asks the operator, i.e., normally the driver, to shift to a higher gear, which is indicated in Figure 1 by the upward pointing arrow within operating range I.</b>”</p> <p>E.g., pages 7 to 8 (English translation), “The two control circuits 2 and 3 are selectively closed by engine-speed dependent change-over switch 6, to which a signal that corresponds to the individual engine speed <math>n</math> is forwarded and which is developed in such a way that <b>at engine speeds that are greater than predefined engine speed <math>n_1</math> (see Figure 1), its shift lever pivots upwardly in Figure 2, but at engine speeds that are smaller than predefined engine speed <math>n_2</math>, it pivots in the downward direction from a neutral center position</b>, which it therefore assumes when engine speed values between <math>n_1</math> and <math>n_2</math> are present.”</p> <p>E.g., Figure 1:</p>		<p>These sensors may include a battery voltage sensor 134, an air temperature sensor 136, an engine temperature sensor 138, an engine speed sensor 140, an ignition timing sensor 142, a barometric pressure sensor 144, and a throttle position sensor 146.”</p> <p>E.g., col. 9, lines 48 to 55, “The CPU 130 receives and processes the signals from the various sensors described above and generates control signals which are used to control fuel pump speed, to maintain the speed of operation of the fuel pump at a rate which provides a pressure in the circulation conduit portion immediately downstream therefrom which is approximately equal to the preset maximum pressure of the pressure regulator 114.”</p> <p>E.g., col. 11, lines 22 to 33, “As indicated at 303 the CPU determines from the reading taken at 302 whether or not the engine RPM is greater than 0. If engine RPM is greater than 0, the CPU next makes the determination from the throttle position reading of 302 whether or not the throttle position is greater than a predetermined</p>

Limitation of '781 Patent Claim 25	Automotive Electronics Handbook (Jurgen)	German Patent Application Publication No. 29 26 070 (Volkswagen '070)	U.S. Patent No. 5,357,438 (Davidian)	U.S. Patent No. 4,901,701 (Chasteen)
		 <p>E.g., Figure 2:</p> 		<p>amount, such as 20°, as indicated in block 304. If throttle position is less than 20°, the CPU decision-making process returns to block 302. If the throttle position is greater than the predetermined amount and RPM = 0, the CPU provides a control command to the engine fuel injector(s) to prime the engine.”</p> <p>E.g., August 6, 1998 Office Action, “Chasteen discloses the sensors as discussed for sensing the signals and a processor and compare manifold pressure for activating the fuel injection. Chasteen discloses the speed (RPM) and throttle position are determined to be greater than 0 (increasing) and the CPU provides a control command to the engine fuel injector to prime the engine (See column 11, lines 22-33) therefore on [sic] would consider increasing and decreasing the speed and throttle for adjusting the fuel injector for supplying fuel to the engine.”</p>

Limitation of '781 Patent Claim 27	Automotive Electronics Handbook (Jurgen)	German Patent Application Publication No. 29 26 070 (Volkswagen '070)	U.S. Patent No. 5,357,438 (Davidian)	U.S. Patent No. 4,901,701 (Chasteen)
<p>27. Apparatus for optimizing operation of a vehicle according to claim 26 wherein said processor subsystem further comprises:</p>	<p>See claim 26 claim chart, at page A-139.</p>	<p>See claim 26 claim chart, at page A-139.</p>	<p>See claim 26 claim chart, at page A-139.</p>	<p>E.g., col. 1, lines 9 to 13, "The present invention relates generally to two-stroke operating cycle engines and, more particularly, to a two stroke engine fuel injection system and control system therefor which are adapted for extreme weather conditions."</p> <p>E.g., col. 2, lines 2 to 17, "Small, two-cycle engines are especially subject to malfunction under variable operating conditions such as changes in sea level, with associated barometric changes and changes in ambient air temperature. Many machines such as snowmobiles, snowblowers, dirt bikes, etc., are operated in such widely variable operating conditions. In view of the costs associated with engine modification for sensors' need for electronic control of fuel injectors and in view of the fact that the engine parameters which are critical to control of fuel injectors for two-cycle engines were not, prior to the present invention, understood in the art, a successful electronically-controlled fuel injection system for small, two-cycle engines which are subject to</p>

Limitation of '781 Patent Claim 27	Automotive Electronics Handbook (Jurgen)	German Patent Application Publication No. 29 26 070 (Volkswagen '070)	U.S. Patent No. 5,357,438 (Davidian)	U.S. Patent No. 4,901,701 (Chasteen)
				extremes in operating conditions has not been developed in the prior art.”
means for determining when road speed for said vehicle is decreasing;	<p>E.g., page 7.6, “There are several applications for rotational speed sensing. First it is necessary to monitor engine speed. This information is used for transmission control, engine control, cruise control, and possibly for a tachometer. Electronics and electronic sensing in the automobile were brought about by the need for higher efficiency engines, better fuel economy, increased power and performance, and lower emissions. Second, <i>wheel speed sensing is required</i> for use in transmissions, cruise control, speedometers, antilock brake systems (ABS), traction control (ASR), variable ratio power steering assist, four-wheel steering, and possibly in inertial navigation and air bag deployment applications.”</p> <p>E.g., page 7.8, “In electronic transmission applications, <i>information from the road and engine speed sensors</i>, as well as torque data and throttle position are required for the MCU to select the optimum</p>		E.g., col. 4, lines 60 to 66, “Vehicle 2 is further equipped with a <i>speed sensor 12 which may sense the speed of the vehicle in any known manner</i> , for example using the speed measuring system of the vehicle itself, or a speed measuring system independent of the vehicle, e.g., an acceleration sensor, or by calculations based on the Doppler effect, etc.”	

Limitation of '781 Patent Claim 27	Automotive Electronics Handbook (Jurgen)	German Patent Application Publication No. 29 26 070 (Volkswagen '070)	U.S. Patent No. 5,357,438 (Davidian)	U.S. Patent No. 4,901,701 (Chasteen)
	gear ratio.”			
means for determining when throttle position for said vehicle is increasing;	<p>E.g., page 12.18, “To control the idle speed, the ECU uses inputs from the <i>throttle position sensor</i>, air conditioning, automatic transmission, power steering, charging system, engine RPM, and vehicle speed.”</p> <p>E.g., page 12.21, “The electronic injection unit also houses the <i>throttle position sensor</i> and, in some cases, an inlet air temperature sensor which provides operating condition information to the ECU.”</p>	E.g., page 6 (English translation), “As can be seen when viewing Figure 1 to begin with, output N of the engine has been plotted across engine speed n. a is the curve of the output at full load, b is a line that represents a constant setting of the output control element, i.e., a line that represents a constant <i>throttle valve angle</i> in a carburetor engine.”	E.g., col. 4, lines 60 to 66, “Vehicle 2 is further equipped with a <i>speed sensor 12 which may sense the speed of the vehicle in any known manner</i> , for example using the speed measuring system of the vehicle itself, or a speed measuring system independent of the vehicle, e.g., an acceleration sensor, or by calculations based on the Doppler effect, etc.”	E.g., col. 9, lines 3 to 8, “These sensors may include a battery voltage sensor 134, an air temperature sensor 136, an engine temperature sensor 138, an engine speed sensor 140, an ignition timing sensor 142, a barometric pressure sensor 144, and a <i>throttle position sensor 146</i> .”  E.g., FIG. 1
means for determining when manifold pressure for said vehicle is increasing; and	<p>E.g., page 2.5, “Automotive specification and testing guidelines have been developed and published by the Society of Automotive Engineers (SAE) specifically for <i>manifold absolute pressure (MAP) sensors</i>.”</p> <p>E.g., page 2.7, “Manifold absolute pressure (MAP) is used as an input to fuel and ignition control in internal combustion engine control systems. <i>The speed-density system that uses the MAP sensor</i> has been preferred over</p>	<p>E.g., page 6 (English translation), “As can be seen when viewing Figure 1 to begin with, output N of the engine has been plotted across engine speed n. a is the curve of the output at full load, b is a line that represents a constant setting of the output control element, i.e., a line that represents a constant throttle valve angle in a carburetor engine. As a measure thereof, in addition to the throttle valve angle itself, it is also possible to use the <i>induction manifold vacuum</i>.”</p> <p>E.g., page 9 (English translation), “It is useful if in addition to this device, a display of the route-specific fuel</p>		

Limitation of '781 Patent Claim 27	Automotive Electronics Handbook (Jurgen)	German Patent Application Publication No. 29 26 070 (Volkswagen '070)	U.S. Patent No. 5,357,438 (Davidian)	U.S. Patent No. 4,901,701 (Chasteen)
	<p>mass air flow (MAF) control because it's less expensive, but stricter emission standards are causing more manufacturers to use mass air flow for future models."</p>	<p>consumption is provided in a vehicle. Such display devices are known per se; they generally utilize the <i>injection manifold vacuum</i> as a measure of fuel consumption."</p>		
<p>means for determining when engine speed for said vehicle is decreasing;</p>	<p>E.g., page 7.6, "There are several applications for rotational speed sensing. <i>First it is necessary to monitor engine speed.</i> This information is used for transmission control, engine control, cruise control, and possibly for a tachometer. Electronics and electronic sensing in the automobile were brought about by the need for higher efficiency engines, better fuel economy, increased power and performance, and lower emissions. Second, wheel speed sensing is required for use in transmissions, cruise control, speedometers, antilock brake systems (ABS), traction control (ASR), variable ratio power steering assist, four-wheel steering, and possibly in inertial navigation and air bag deployment applications."</p> <p>E.g., page 7.8, "In electronic transmission applications, <i>information from the road</i></p>	<p>E.g., page 6 (English translation), "The operating ranges I and II are further delimited by <i>engine speed</i> values <math>n_1</math> or <math>n_2</math>, the first of which usually lies between approximately 20 to 50% of the maximum engine speed, and the second usually lies between approximately 40 and 70% of the maximum engine speed."</p> <p>E.g., page 8 (English translation), "<i>The engine speed signal is obtained with the aid of known sensor systems</i>, which therefore need not be described in further detail here."</p>		<p>E.g., col. 9, lines 3 to 8, "These sensors may include a battery voltage sensor 134, an air temperature sensor 136, an engine temperature sensor 138, <i>an engine speed sensor 140</i>, an ignition timing sensor 142, a barometric pressure sensor 144, and a throttle position sensor 146."</p> <p>E.g., FIG. 1</p>

Limitation of '781 Patent Claim 27	Automotive Electronics Handbook (Jurgen)	German Patent Application Publication No. 29 26 070 (Volkswagen '070)	U.S. Patent No. 5,357,438 (Davidian)	U.S. Patent No. 4,901,701 (Chasteen)
	<p><i>and engine speed sensors, as well as torque data and throttle position are required for the MCU to select the optimum gear ratio."</i></p>			
<p>said processor subsystem activating said downshift notification circuit if both road speed and engine speed are decreasing and both throttle position and manifold pressure for said vehicle are increasing.</p>	<p>E.g., page 13.7 to 13.9, "<b><i>The basic functions of the transmission control are the shift point control</i></b>, the lockup control, engine torque control during shifting, related safety functions, and diagnostic functions for vehicle service." E.g., page 13.9, "The basic shift point control uses shift maps, which are defined in data in the unit memory. These shift maps are selectable over a wide range. <b><i>The shift point limitations are made</i></b>, on the one hand, by the highest admissible engine speed for each application and, on the other hand, <b><i>by the lowest engine speed that is practical for driving comfort and noise emission. The inputs of the shift point determination are the throttle position, the accelerator pedal position, and the vehicle speed</i></b> (determined by the transmission output speed)."</p>	<p>E.g., pages 6 to 7 (English translation), "Looking initially at operating range I remote from full load, <b><i>the desired output at a lower specific fuel consumption is able to be achieved after upshifting into the next higher gear</i></b>, at an operating point that lies to the left of operating range I in the diagram of Figure 1. <b><i>Accordingly, the device of the present invention generates a signal that asks the operator, i.e., normally the driver, to shift to a higher gear, which is indicated in Figure 1 by the upward pointing arrow within operating range I.</i></b>"</p> <p>E.g., pages 7 to 8 (English translation), "The two control circuits 2 and 3 are selectively closed by engine-speed dependent change-over switch 6, to which a signal that corresponds to the individual engine speed <math>n</math> is forwarded and which is developed in such a way that <b><i>at engine speeds that are greater than predefined engine speed <math>n_1</math> (see Figure 1), its shift lever pivots upwardly in Figure 2, but at engine speeds that are smaller than predefined engine speed <math>n_2</math>, it pivots in the downward direction from a neutral center position</i></b>, which it therefore assumes when engine speed values between <math>n_1</math> and <math>n_2</math> are</p>		<p>E.g., col. 9, lines 1 to 8, "The electronic control assembly comprises a number of sensors having sensor outputs which are provided to the CPU 130 through interface circuitry 132. These sensors may include a battery voltage sensor 134, an air temperature sensor 136, an engine temperature sensor 138, an engine speed sensor 140, an ignition timing sensor 142, a barometric pressure sensor 144, and a throttle position sensor 146."</p> <p>E.g., col. 9, lines 48 to 55, "The CPU 130 receives and processes the signals from the various sensors described above and generates control signals which are used to control fuel pump speed, to maintain the speed of operation of the fuel pump at a rate which provides a pressure in the circulation conduit portion immediately downstream therefrom which is approximately equal to the preset maximum pressure of</p>

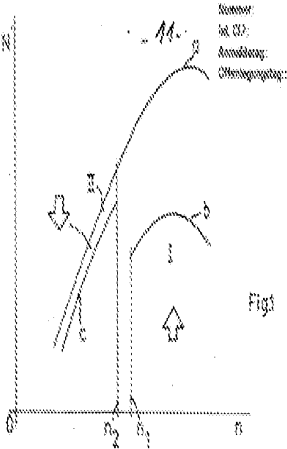
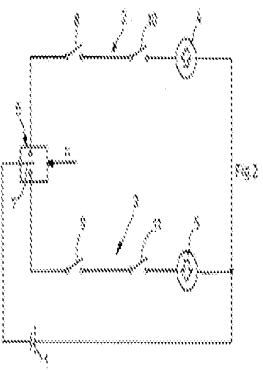
Limitation of '781 Patent Claim 27	Automotive Electronics Handbook (Jurgen)	German Patent Application Publication No. 29 26 070 (Volkswagen '070)	U.S. Patent No. 5,357,438 (Davidian)	U.S. Patent No. 4,901,701 (Chasteen)
		<p>present.”</p> <p>E.g., Figure 1:</p>  <p>E.g., Figure 2:</p> 		<p>the pressure regulator 114.”</p> <p>E.g., col. 11, lines 22 to 33, “As indicated at 303 the CPU determines from the reading taken at 302 whether or not the engine RPM is greater than 0. If engine RPM is greater than 0, the CPU next makes the determination from the throttle position reading of 302 whether or not the throttle position is greater than a predetermined amount, such as 20°, as indicated in block 304. If throttle position is less than 20°, the CPU decision-making process returns to block 302. If the throttle position is greater than the predetermined amount and RPM = 0, the CPU provides a control command to the engine fuel injector(s) to prime the engine.”</p> <p>E.g., August 6, 1998 Office Action, “Chasteen discloses the sensors as discussed for sensing the signals and a processor and compare manifold pressure for activating the fuel injection. Chasteen discloses the speed (RPM) and throttle position are determined to be greater than 0 (increasing) and the CPU provides a control command to</p>



Limitation of '781 Patent Claim 27	Automotive Electronics Handbook (Jurgen)	German Patent Application Publication No. 29 26 070 (Volkswagen '070)	U.S. Patent No. 5,357,438 (Davidian)	U.S. Patent No. 4,901,701 (Chasteen)
				<p>the engine fuel injector to prime the engine (See column 11, lines 22-33) therefore on [sic] would consider increasing and decreasing the speed and throttle for adjusting the fuel injector for supplying fuel to the engine.”</p>

**21. Claim 32 is Obvious in View of the Combination of Davidian and Tonkin**

Limitation of '781 Patent Claim 32	U.S. Patent No. 5,357,438 (Davidian)	PCT Publication No. WO 96/02853 (Tonkin)
<p>32. Apparatus for optimizing operation of a vehicle according to claim 31 wherein:</p>	<p>See claim 31 claim chart, at page A-225.</p>	<p>E.g., Abstract, “The system comprising a controller fitted to a subject vehicle (16) and sensor means (20) operable to sense a distance of separation and relative velocity of a trailing vehicle (18). Also input to the controller is a velocity signal derived from a velocity sensing means (97) determining the ground speed of the subject vehicle using a doppler radar system. The controller calculates a safety envelope and activates a visible warning device attached to the rear of the subject vehicle if the trailing vehicle penetrates the safety envelope. An enhanced safety envelope determined by adverse road conditions is also established, any incursion into the enhanced envelope resulting generally in the visible warning being at a less prominent level. If however the closing speed of the trailing vehicle exceeds a predetermined threshold, penetration of the enhanced envelope results immediately in the full warning being displayed with full prominence to the driver of the trailing vehicle. The system has application to improving the safety of road vehicles.”</p>
<p>said at least one sensor further includes a windshield wiper sensor for indicating whether a windshield wiper of said vehicle is activated; and</p>	<p>E.g., col. 4, line 67 to col. 5, line 2, “The automatic sensors on vehicle 2 further include a daylight sensor 14, <b>a rain sensor 16</b>, a vehicle load sensor 18, a trailer-hitch sensor 20, and a reverse gear sensor 22.”</p> <p>E.g., col. 8, lines 58 to 63, “Thus, module 90 receives inputs from the front space sensor 8, the rear space sensor 10, and the vehicle speed sensor 12. <b>Module 90 also receives inputs from the sensors in case there is no depressible key, e.g., the daylight sensor 14, the trailer sensor 20, the reverse gear sensor 22, the rain sensor 16, and the vehicle load sensor 18.</b>”</p>	<p>E.g., page 18, lines 9 to 13, “The information regarding the weather might be obtained for example by enabling the warning system controller to ascertain if the windscreen wipers are in use or have been in use recently due to rain (and not used with a water spray to clean the windscreen).”</p>
<p>said memory subsystem further storing a second vehicle speed/stopping distance table;</p>	<p>E.g., col. 9, lines 20 to 27, “<b>Computer module 90 also includes information about the vehicle braking distances as a function of speed. This is preferably in</b></p>	<p>E.g., page 18, lines 16 to 19, “Thus, safe stopping distances can be adjusted for prevailing weather conditions, again by providing stored values according to</p>

Limitation of '781 Patent Claim 32	U.S. Patent No. 5,357,438 (Davidian)	PCT Publication No. WO 96/02853 (Tonkin)
	<p><i>the form of a look-up table</i>, for example, provided by the manufacturer for predetermined defined conditions concerning road type, skidding danger, vehicle load and tires pressure, and is <i>stored in a ROM (read-only memory) of the microcomputer so that it can be changed periodically if necessary.</i>"</p> <p>E.g., col. 12, line 59 to col 13, line 22, "The system then makes the computations illustrated (as an example) in block 162 to determine the stopping distance SD, which is equal to the reaction distance plus the braking distance multiplied by a stopping factor ST and a safety factor SF. <b><i>In the illustrated example, the stopping distance is the sum of the reaction distance and the braking distance.</i></b> The reaction distance is the product of the reaction time, visibility condition, daylight condition, reaction factor and speed; and <b><i>the braking distance is the product of the braking distance (as supplied by the manufacturer), road type, skidding danger, vehicle load and braking factor.</i></b> The stopping distance (SD) includes further safety factors, and determines when the safety alarm will be actuated to first alert the driver of an approaching collision danger.</p> <p>A determination is also made of the collision distance CD which is equal to the stopping distance SD divided by the collision safety factor CSF, e.g., 1.25 in the example illustrated above, such that should the distance between the vehicle and the object come within the collision distance CD, the collision alarm is then actuated.</p> <p>The foregoing calculations of stopping distance SD and collision distance CD with respect to objects at the front of the vehicle are also made with respect to objects at the rear of the vehicle, these calculations being RSD and RCD, respectively, also shown in block 162.</p> <p>Whenever the distance between the vehicle and an object</p>	<p>weather and possibly for different severities of poor weather."</p> <p>E.g., page 3, lines 25 to 32, "The size of the enhanced safe distance and enlarged safety envelope will generally be predetermined so as to correspond to typical parameters appropriate for driving under adverse road conditions. <b><i>These parameters may for example be stored in a look up table</i></b> allowing the parameters to be determined from the signals received by the controller together with the parameters defining the normal safety envelope."</p> <p>E.g., page 16, lines 2 to 21, "The control system is designed to activate display 12 to provide a warning signal to a driver of the trailing vehicle when the trailing vehicle 18 when the trailing vehicle is closing too rapidly on the subject vehicle 16 for example, alternately a warning signal is displayed when the trailing vehicle 18 is too close to the subject vehicle 16. Even if they are travelling at the same speed for example, <b><u>there are known safe stopping distances such as those published by the Minister of Transport</u></b>, in which a vehicle will stop when the brakes are applied. Accordingly, by knowing the velocity of the subject vehicle 16 for example preferably using the radar ground sensing system described herein, which provides therefore a true ground speed, or other means in communication with a microprocessor control system and by using a proximity sensor 20 to determine the separation of the subject vehicle 16 from the trailing vehicle 18 a safety envelope can be created behind the subject vehicle 16. Intrusion in the envelope by the trailing vehicle 18 causes an initial level of lamps 13 in array 12 to be lit."</p> <p>E.g., page 17, lines 7 to 25, "Thus a warning system has been described using a ground speed sensor for a subject vehicle 16 coupled by a microprocessor with a proximity sensor 20. In a more sophisticate [sic] version, proximity</p>

Limitation of '781 Patent Claim 32	U.S. Patent No. 5,357,438 (Davidian)	PCT Publication No. WO 96/02853 (Tonkin)
	<p>to the front of the vehicle or to the rear of the vehicle comes within the stopping distance SD and the collision distance CD, the system operates according to the deceleration alarm module 93, as indicated by block 164.”</p>	<p>sensor 20 could be a radar device described herein for measuring velocity and could therefore be used to measure the relative velocity of a subject vehicle 16 and trailing vehicle 18. By knowing the closing speed of the trailing vehicle 18 predetermined values could be used to trigger warning displays if the closing speed is too great. <i>For example, a look-up table or database could again be provided for unsafe closing speeds. This look-up table might again be varied according to the velocity of the subject vehicle 16 in a similar manner to the safe stopping distance, or safety envelope distance.</i> Therefore, whilst the safety envelope distance at 30mph is 25 metres, if the trailing vehicle is closing too rapidly, say, a difference in speed of 30mph, then the warning signal could be activated even when the trailing vehicle 18 is 50 metres behind the subject vehicle 16.”</p>
<p>if said windshield wiper sensor indicates that said windshield wiper is deactivated, said processor subsystem determining whether to activate said vehicle proximity alarm circuit based upon data received from said radar detector, said road speed sensor and said first vehicle speed/stopping distance table stored in said memory subsystem;</p>	<p>E.g., col. 8, lines 37 to 43, “The <i>microcomputer 4</i> as illustrated in FIGS. 6a, 6b is divided into various functional modules, as follows: a calculation module 90, <i>which receives data concerning the various parameters briefly described above</i> and as will be described more particularly below <i>to enable it to make the necessary computations for actuating the Safety alarm and the Collision alarm; ...</i>”</p> <p>E.g., col. 12, line 59 to col 13, line 11, “The system then makes the computations illustrated (as an example) in block 162 to determine the stopping distance SD, which is equal to the reaction distance plus the braking distance multiplied by a stopping factor ST and a safety factor SF. In the illustrated example, the stopping distance is the sum of the reaction distance and the braking distance. The reaction distance is the product of the reaction time, visibility condition, daylight condition, reaction factor and speed; and the braking distance is the product of the braking distance (as supplied by the manufacturer), road type, skidding danger, vehicle load and braking factor. <i>The stopping distance (SD) includes further safety</i></p>	<p>E.g., page 18, lines 16 to 19, “Thus, safe stopping distances can be adjusted for prevailing weather conditions, again by providing stored values according to weather and possibly for different severities of poor weather.”</p> <p>E.g., page 3, lines 25 to 32, “The size of the enhanced safe distance and enlarged safety envelope will generally be predetermined so as to correspond to typical parameters appropriate for driving under adverse road conditions. <i>These parameters may for example be stored in a look up table</i> allowing the parameters to be determined from the signals received by the controller together with the parameters defining the normal safety envelope.”</p> <p>E.g., page 16, lines 2 to 21, “The control system is designed to activate display 12 to provide a warning signal to a driver of the trailing vehicle when the trailing vehicle 18 when the trailing vehicle is closing too rapidly on the subject vehicle 16 for example, alternately a warning signal is displayed when the trailing vehicle 18</p>

Limitation of '781 Patent Claim 32	U.S. Patent No. 5,357,438 (Davidian)	PCT Publication No. WO 96/02853 (Tonkin)
	<p><i>factors, and determines when the safety alarm will be actuated to first alert the driver of an approaching collision danger.</i></p> <p><i>A determination is also made of the collision distance CD which is equal to the stopping distance SD divided by the collision safety factor CSF, e.g., 1.25 in the example illustrated above, such that should the distance between the vehicle and the object come within the collision distance CD, the collision alarm is then actuated.”</i></p> <p>E.g., col. 13, lines 17 to 22, <i>“Whenever the distance between the vehicle and an object to the front of the vehicle or to the rear of the vehicle comes within the stopping distance SD and the collision distance CD, the system operates according to the deceleration alarm module 93, as indicated by block 164.”</i></p>	<p>is too close to the subject vehicle 16. Even if they are travelling at the same speed for example, <u><i>there are known safe stopping distances such as those published by the Minister of Transport</i></u>, in which a vehicle will stop when the brakes are applied. Accordingly, by knowing the velocity of the subject vehicle 16 for example preferably using the radar ground sensing system described herein, which provides therefore a true ground speed, or other means in communication with a microprocessor control system and by using a proximity sensor 20 to determine the separation of the subject vehicle 16 from the trailing vehicle 18 a safety envelope can be created behind the subject vehicle 16. Intrusion in the envelope by the trailing vehicle 18 causes an initial level of lamps 13 in array 12 to be lit.”</p> <p>E.g., page 17, lines 7 to 25, <i>“Thus a warning system has been described using a ground speed sensor for a subject vehicle 16 coupled by a microprocessor with a proximity sensor 20. In a more sophisticate [sic] version, proximity sensor 20 could be a radar device described herein for measuring velocity and could therefore be used to measure the relative velocity of a subject vehicle 16 and trailing vehicle 18. By knowing the closing speed of the trailing vehicle 18 predetermined values could be used to trigger warning displays if the closing speed is too great. For example, a look-up table or database could again be provided for unsafe closing speeds. This look-up table might again be varied according to the velocity of the subject vehicle 16 in a similar manner to the safe stopping distance, or safety envelope distance.</i> Therefore, whilst the safety envelope distance at 30mph is 25 metres, if the trailing vehicle is closing too rapidly, say, a difference in speed of 30mph, then the warning signal could be activated even when the trailing vehicle 18 is 50 metres behind the subject vehicle 16.”</p>
if said windshield wiper sensor indicates that said windshield wiper is activated, said processor subsystem	E.g., col. 8, lines 37 to 43, <i>“The microcomputer 4 as illustrated in FIGS. 6a, 6b is divided into various</i>	E.g., page 18, lines 16 to 19, <i>“Thus, safe stopping distances can be adjusted for prevailing weather</i>

Limitation of '781 Patent Claim 32	U.S. Patent No. 5,357,438 (Davidian)	PCT Publication No. WO 96/02853 (Tonkin)
<p>determining whether to activate said vehicle proximity alarm circuit based upon data received from said radar detector, said road speed sensor and said second vehicle speed/stopping distance table stored in said memory subsystem.</p>	<p>functional modules, as follows: a calculation module 90, <i>which receives data concerning the various parameters briefly described above</i> and as will be described more particularly below <i>to enable it to make the necessary computations for actuating the Safety alarm and the Collision alarm; ...</i></p> <p>E.g., col. 12, line 59 to col 13, line 11, "The system then makes the computations illustrated (as an example) in block 162 to determine the stopping distance SD, which is equal to the reaction distance plus the braking distance multiplied by a stopping factor ST and a safety factor SF. In the illustrated example, the stopping distance is the sum of the reaction distance and the braking distance. The reaction distance is the product of the reaction time, visibility condition, daylight condition, reaction factor and speed; and the braking distance is the product of the braking distance (as supplied by the manufacturer), road type, skidding danger, vehicle load and braking factor. <i>The stopping distance (SD) includes further safety factors, and determines when the safety alarm will be actuated to first alert the driver of an approaching collision danger.</i></p> <p><i>A determination is also made of the collision distance CD which is equal to the stopping distance SD divided by the collision safety factor CSF, e.g., 1.25 in the example illustrated above, such that should the distance between the vehicle and the object come within the collision distance CD, the collision alarm is then actuated."</i></p> <p>E.g., col. 13, lines 17 to 22, "<i>Whenever the distance between the vehicle and an object to the front of the vehicle or to the rear of the vehicle comes within the stopping distance SD and the collision distance CD, the system operates according to the deceleration alarm module 93, as indicated by block 164.</i>"</p>	<p>conditions, again by providing stored values according to weather and possibly for different severities of poor weather."</p> <p>E.g., page 3, lines 25 to 32, "The size of the enhanced safe distance and enlarged safety envelope will generally be predetermined so as to correspond to typical parameters appropriate for driving under adverse road conditions. <i>These parameters may for example be stored in a look up table</i> allowing the parameters to be determined from the signals received by the controller together with the parameters defining the normal safety envelope."</p> <p>E.g., page 16, lines 2 to 21, "The control system is designed to activate display 12 to provide a warning signal to a driver of the trailing vehicle when the trailing vehicle 18 when the trailing vehicle is closing too rapidly on the subject vehicle 16 for example, alternately a warning signal is displayed when the trailing vehicle 18 is too close to the subject vehicle 16. Even if they are travelling at the same speed for example, <u>there are known safe stopping distances such as those published by the Minister of Transport</u>, in which a vehicle will stop when the brakes are applied. Accordingly, by knowing the velocity of the subject vehicle 16 for example preferably using the radar ground sensing system described herein, which provides therefore a true ground speed, or other means in communication with a microprocessor control system and by using a proximity sensor 20 to determine the separation of the subject vehicle 16 from the trailing vehicle 18 a safety envelope can be created behind the subject vehicle 16. Intrusion in the envelope by the trailing vehicle 18 causes an initial level of lamps 13 in array 12 to be lit."</p> <p>E.g., page 17, lines 7 to 25, "Thus a warning system has been described using a ground speed sensor for a subject vehicle 16 coupled by a microprocessor with a proximity</p>

Limitation of '781 Patent Claim 32	U.S. Patent No. 5,357,438 (Davidian)	PCT Publication No. WO 96/02853 (Tonkin)
		<p>sensor 20. In a more sophisticate [sic] version, proximity sensor 20 could be a radar device described herein for measuring velocity and could therefore be used to measure the relative velocity of a subject vehicle 16 and trailing vehicle 18. By knowing the closing speed of the trailing vehicle 18 predetermined values could be used to trigger warning displays if the closing speed is too great.</p> <p><i>For example, a look-up table or database could again be provided for unsafe closing speeds. This look-up table might again be varied according to the velocity of the subject vehicle 16 in a similar manner to the safe stopping distance, or safety envelope distance.</i></p> <p>Therefore, whilst the safety envelope distance at 30mph is 25 metres, if the trailing vehicle is closing too rapidly, say, a difference in speed of 30mph, then the warning signal could be activated even when the trailing vehicle 18 is 50 metres behind the subject vehicle 16.”</p>

# **EXHIBIT 1**





US005954781A

# United States Patent [19] Slepian et al.

[11] **Patent Number:** 5,954,781  
[45] **Date of Patent:** Sep. 21, 1999

- [54] **METHOD AND APPARATUS FOR OPTIMIZING VEHICLE OPERATION**
- [75] Inventors: **Harvey Slepian**, Peoria; **Loran Sutton**, East Peoria, both of Ill.
- [73] Assignee: **TAS Distributing Co., Inc.**, Peoria, Ill.
- [21] Appl. No.: **08/813,270**
- [22] Filed: **Mar. 10, 1997**
- [51] **Int. Cl.<sup>6</sup>** ..... **G06F 7/00**
- [52] **U.S. Cl.** ..... **701/96; 701/103; 340/425.5; 340/438**
- [58] **Field of Search** ..... 701/1, 121, 123, 701/101, 102, 103, 104, 96, 300; 123/478, 480, 351, 481; 340/903, 425.5, 426, 436, 438

*Primary Examiner*—William A. Cuchlinski, Jr.  
*Assistant Examiner*—Gertrude Arthur  
*Attorney, Agent, or Firm*—Haynes and Boone, LLP

### [57] ABSTRACT

Apparatus for optimizing operation of an engine-driven vehicle. The apparatus includes a processor subsystem, a memory subsystem, a road speed sensor, an engine speed sensor, a manifold pressure sensor, a throttle position sensor, a radar detector for determining the distance separating the vehicle from an object in front of it, a windshield wiper sensor for indicating whether a windshield wiper of the vehicle is activated, a brake sensor for determining whether the brakes of the vehicle have been activated, a fuel over-injection notification circuit for issuing notifications that excessive fuel is being supplied to the engine of the vehicle, an upshift notification circuit for issuing notifications that the engine of the vehicle is being operated at an excessive engine speed, a downshift notification circuit for issuing notifications that the engine of the vehicle is being operated at an insufficient engine speed, a vehicle proximity alarm circuit for issuing an alarm that the vehicle is too close to an object in front of the vehicle and a throttle controller for automatically reducing the amount of fuel supplied to the engine if the vehicle is too close to the object in front of it. Based upon data received from the sensors and data stored in the memory subsystem, the processor determines whether to activate the fuel overinjection notification circuit, the upshift notification circuit, the downshift notification circuit, the vehicle proximity alarm circuit or the throttle controller.

### [56] References Cited

#### U.S. PATENT DOCUMENTS

4,492,112	1/1985	Igarashi et al.	73/117.3
4,542,460	9/1985	Weber	364/424
4,631,515	12/1986	Blee et al.	340/62
4,701,852	10/1987	Ulveland	364/424.1
4,752,883	6/1988	Asakura et al.	364/424.1
4,853,673	8/1989	Kido et al.	340/439
4,868,756	9/1989	Kawanabe et al.	364/442
4,901,701	2/1990	Chasteen	123/478
5,420,792	5/1995	Butsuen et al.	701/96
5,708,584	1/1998	Doi et al.	701/96
5,745,870	4/1998	Yamamoto et al.	701/96

32 Claims, 3 Drawing Sheets

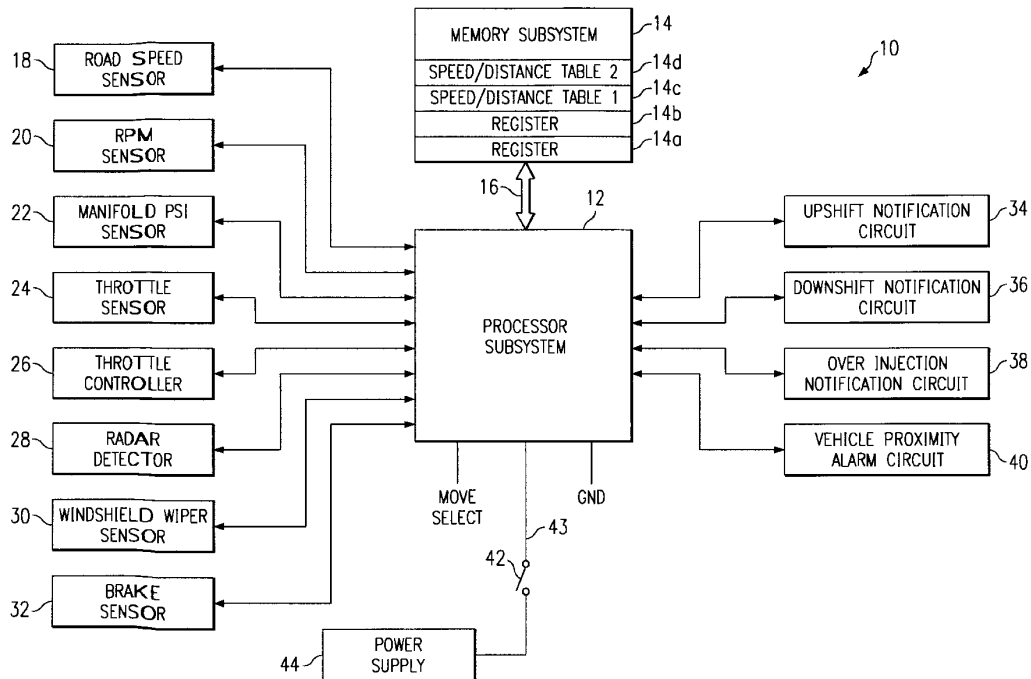

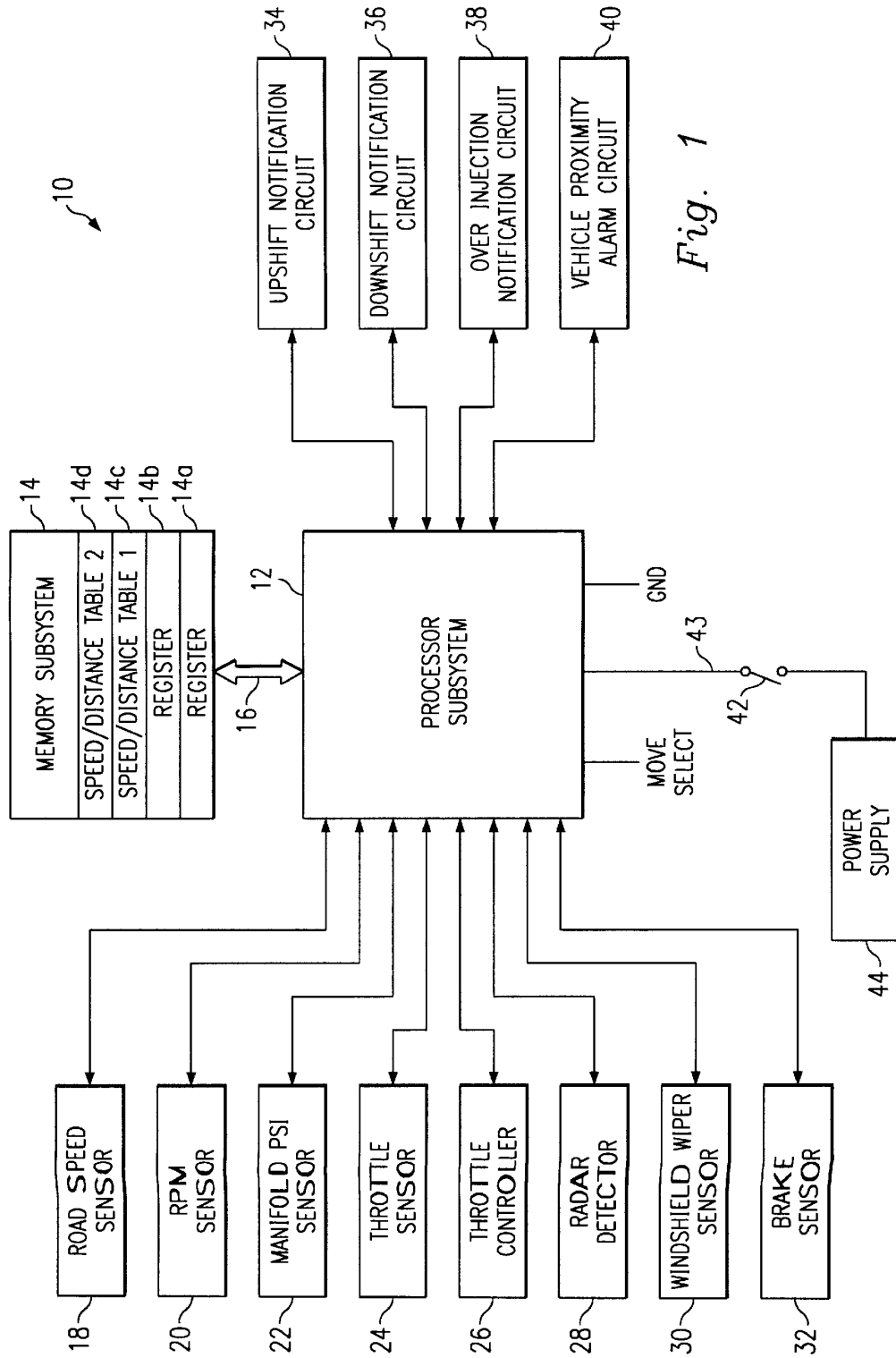
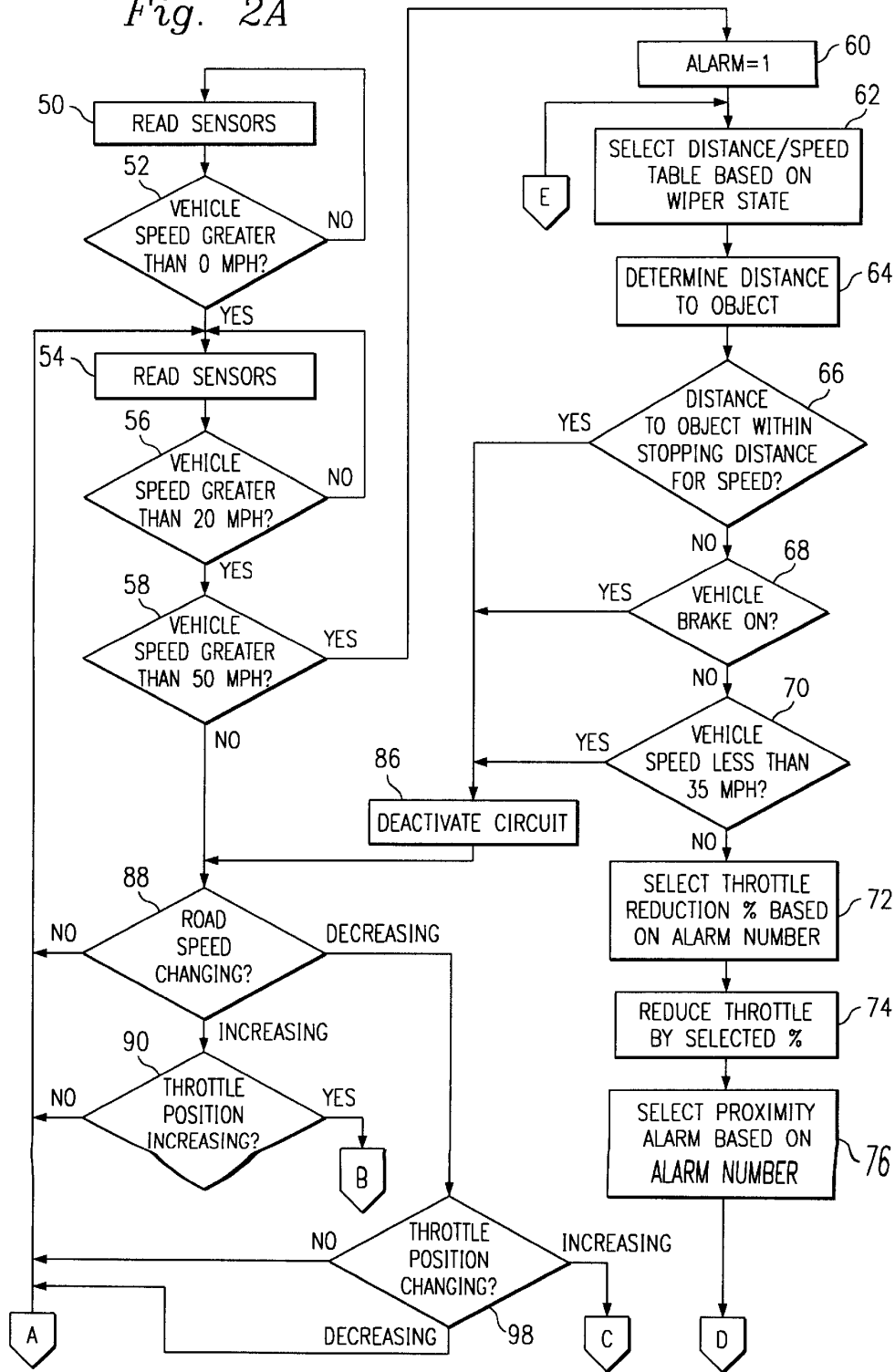
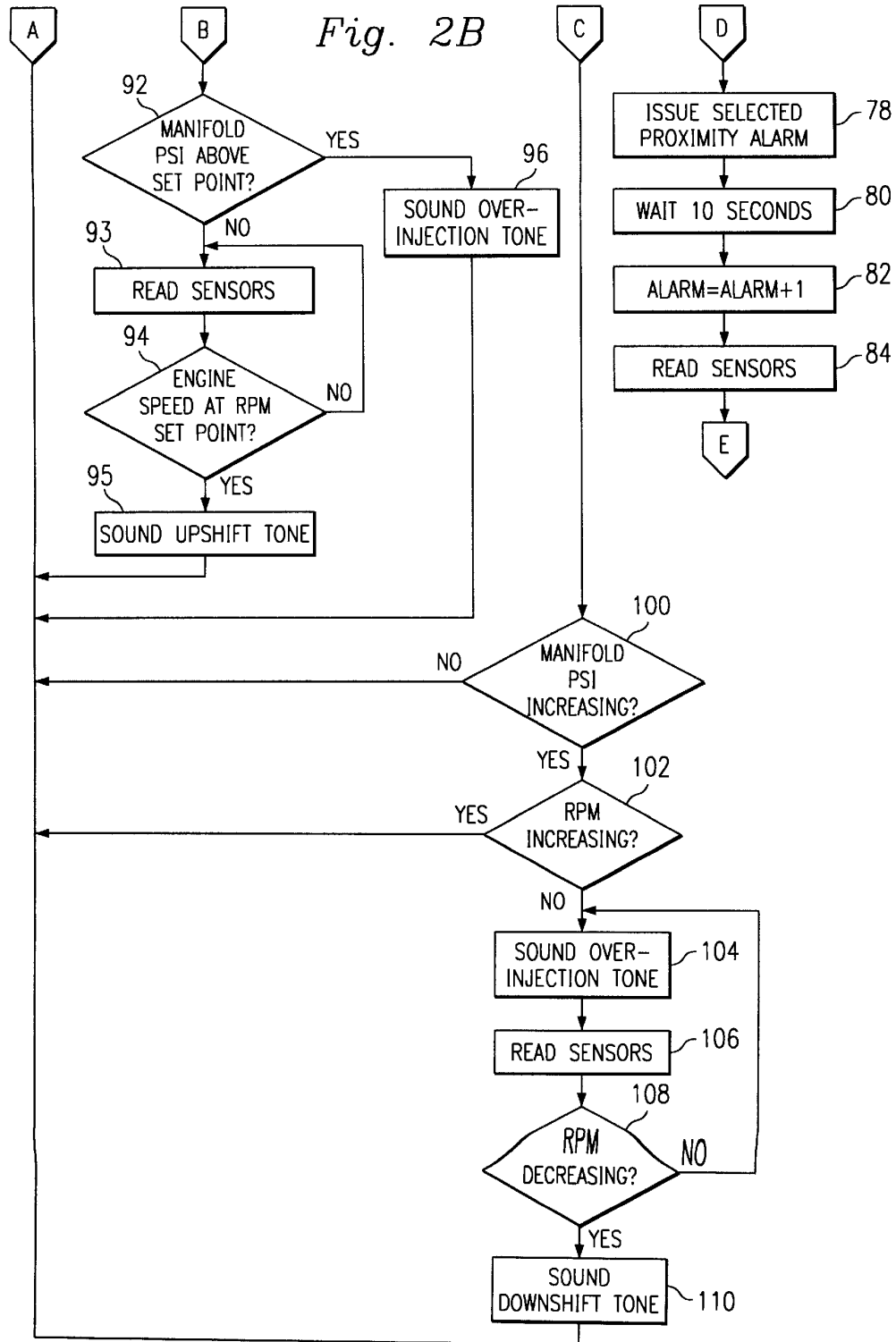

Fig. 1

Fig. 2A





**METHOD AND APPARATUS FOR  
OPTIMIZING VEHICLE OPERATION**

**BACKGROUND OF THE INVENTION**

1. Field of the Invention

The present invention generally relates to an apparatus for optimizing vehicle operation and, more particularly, relates to a system which both notifies the driver of recommended corrections in vehicle operation and, under certain conditions, automatically initiates selected corrective action.

2. Description of Related Art

It has long been recognized that the improper operation of a vehicle may have many adverse effects. For example, the fuel efficiency of a vehicle may vary dramatically based upon how the vehicle is operated. More specifically, operating a vehicle at excessive speed, excessive RPM and/or excessive manifold pressure will result in both reduced fuel economy and increased operating costs. The aforementioned increased operating costs can be quite considerable, particularly for an owner or operator of a fleet of vehicles. To correct these types of improper vehicle operations are often surprisingly simple. For example, upshifting the drive gear will typically eliminate an excessive RPM condition. However, even when the solution is quite simple, oftentimes, the driver will be unaware of the need to take corrective action.

A variety of patents have disclosed systems, commonly referred to as "shift prompters", which monitor the operation of a vehicle and advises the operator of the vehicle when to take certain actions. Numerous ones of these devices include sensors which measure engine speed and vehicle speed. See, for example, U.S. Pat. No. 4,492,112 to Igarashi et al., U.S. Pat. No. 4,631,515 to Blee et al. and U.S. Pat. No. 4,701,852 to Ulveland. Certain ones, however, disclose the use of other types of sensors as well. For example, U.S. Pat. No. 4,524,460 to Weber is directed to a driving aid indicator which includes vehicle speed, manifold pressure, throttle position and engine speed sensors. U.S. Pat. No. 4,752,883 to Asakura et al. and U.S. Pat. No. 4,868,756 to Kawanabe et al. are directed to upshift notification devices which include sensors for measuring engine speed, vehicle speed, manifold pressure and cooling water temperature. Finally, U.S. Pat. No. 4,853,673 to Kido et al. discloses a shift indicator system which includes sensors for measuring engine speed and throttle position. Generally, the above-listed patents all provide displays intended to enable the driver to operate the vehicle in a manner leading to uniform performance and maximum fuel economy. However, Blee et al. discloses the use of audible warnings as well as a speed controller to prevent further increases in engine speed if the driver ignores previously issued warnings.

Improper vehicle operation has other adverse effects as well. It is well known that the faster a vehicle travels, the longer it takes to stop. Thus, what may be a safe separation distance between successive vehicles when a vehicle is traveling at 35 mph may be unsafe if that vehicle is traveling at 50 mph. Road conditions also play a role in determining the safe separation distance between vehicles. For example, greater separation distances are generally recommended when roads are wet. As a result, therefore, based on the combination of a vehicle's speed, the distance separating the vehicle from a second vehicle in front of it and road conditions, many vehicles are operated unsafely. To correct this situation, a reduction in operating speed, an increase in vehicle separation or some combination thereof, is required.

It may be readily seen from the foregoing that it would be desirable to provide a system which integrates the ability to

issue audible warnings which advise the driver to correct operation of the vehicle in a manner which will enhance the efficient operation thereof with the ability to automatically take corrective action if the vehicle is being operated unsafely. It is, therefore, the object of the invention to provide such a system.

**SUMMARY OF THE INVENTION**

In one embodiment, the present invention is directed to an apparatus for optimizing operation of an engine-driven vehicle. The apparatus includes a processor subsystem, a memory subsystem, plural sensors, including road speed, manifold pressure and throttle position sensors, for collectively monitoring operation of the vehicle and a fuel overinjection notification circuit for issuing notifications that excessive fuel is being supplied to the engine of the vehicle. The processor subsystem receives data from the sensors and, from the received data, determines when to activate the fuel overinjection circuit. In one aspect thereof, the processor subsystem determines when road speed for the vehicle is increasing, determines when throttle position for the vehicle is increasing, compares manifold pressure and a manifold pressure set point stored in the memory subsystem and activates the fuel overinjection notification circuit if both road speed and throttle position for the vehicle are increasing and manifold pressure for the vehicle is above the manifold pressure set point.

In further aspects thereof, the sensors may include an engine speed sensor and the processor subsystem may determine when road speed for the vehicle is decreasing, when throttle position for the vehicle is increasing, when manifold pressure for the vehicle is increasing, when engine speed for the vehicle is decreasing and may activate the fuel overinjection notification circuit if both throttle position and manifold pressure for the vehicle are increasing and road speed and engine speed for the vehicle are decreasing.

In still further aspects thereof, the apparatus may also include an upshift notification circuit, activated by the processor subsystem based upon data received from the sensors, which issues notifications that the engine of the vehicle is being operated at excessive engine speeds. In this aspect, the processor subsystem determines when road speed for the vehicle is increasing, when throttle position for the vehicle is increasing, compares manifold pressure to a manifold pressure set point stored in the memory subsystem, compares engine speed to an RPM set point stored in the memory subsystem and activates the upshift notification circuit if both road speed and throttle position for the vehicle are increasing, manifold pressure for the vehicle is at or below the manifold pressure set point and engine speed for the vehicle is at or above the RPM set point.

In still yet further aspects thereof, the apparatus may also include a downshift notification circuit, activated by the processor subsystem based upon data received from the sensors, which issues a notification that the engine of the vehicle is being operated at an insufficient engine speed. The processor subsystem may determine when road speed for the vehicle is decreasing, when throttle position for the vehicle is increasing, when manifold pressure for the vehicle is increasing, when engine speed for the vehicle is decreasing and may activate the downshift notification circuit if both road speed and engine speed are decreasing and both throttle position and manifold pressure for the vehicle are increasing.

In still further aspects thereof, the fuel overinjection circuit, the upshift notification circuit or the downshift

3

notification circuit may include a horn for issuing a tone for a preselected time period.

In another embodiment, the present invention is of an apparatus for optimizing operation of a vehicle. The apparatus includes road speed, engine speed, manifold pressure and throttle position sensors, a processor subsystem coupled to each of the sensors to receive data therefrom and a memory subsystem, coupled to the processor subsystem, for storing a manifold pressure set point, an engine speed set point and present and prior levels for each one of the sensors. The apparatus further includes a fuel overinjection notification circuit, an upshift notification circuit and a downshift notification circuit, all of which are coupled to the processor subsystem. The fuel overinjection notification circuit issues notifications that excessive fuel is being supplied to the engine of the vehicle, the upshift notification circuit issues notifications that the engine of the vehicle is being operated at an excessive engine speed and the downshift notification circuit issues notifications that the engine of the vehicle is being operated at an insufficient engine speed. Based upon data received from the sensors, the processor subsystem determines when to activate the fuel overinjection circuit, the upshift notification circuit and the downshift notification circuit. In one aspect thereof, the fuel overinjection circuit includes a first horn for issuing a first tone for a first preselected time period, the upshift notification circuit includes a second horn for issuing a second tone for a second preselected time period and the downshift notification circuit includes a third horn for issuing a third tone for a third preselected time period.

In another aspect thereof, the processor subsystem may determine when road speed for the vehicle is increasing or decreasing, engine speed is increasing or decreasing, throttle position for the vehicle is increasing and manifold pressure is increasing; may compare manifold pressure to the manifold pressure set point and engine speed to the RPM set point; and may activate the fuel overinjection notification circuit if both road speed and throttle position for the vehicle are increasing and manifold pressure for the vehicle is above the manifold pressure set point or if both throttle position and manifold pressure for the vehicle are increasing and road speed and engine speed for the vehicle are decreasing, the upshift notification circuit if both road speed and throttle position for the vehicle are increasing, manifold pressure for the vehicle is at or below the manifold pressure set point and engine speed for the vehicle is at or above the RPM set point and the downshift notification circuit if both road speed and engine speed are decreasing and both throttle position and manifold pressure for the vehicle are increasing.

In another aspect, the present invention is of an apparatus for optimizing operation of a vehicle which includes a radar detector for determining a distance separating a vehicle having an engine and an object in front of the vehicle and at least one sensor for monitoring operation of the vehicle. The apparatus further includes a processor subsystem, a memory subsystem and a vehicle proximity alarm circuit. The processor subsystem is coupled to the radar detector and the at least one sensor to receive data therefrom while the memory subsystem, in which a first vehicle speed/stopping distance table and present levels for each one of the at least one sensor are stored, and the vehicle proximity alarm circuit are coupled to the processor subsystem. Based on data received from the radar detector, the at least one sensor and the contents of the memory subsystem, the processor determines when to instruct the vehicle proximity alarm circuit to issue an alarm that the vehicle is too close to the object.

In one aspect thereof, the at least one sensor further includes a windshield wiper sensor for indicating whether a

4

windshield wiper of the vehicle is activated and a second vehicle speed/stopping distance table is stored in the memory subsystem. In another aspect thereof, the apparatus further includes a throttle controller for controlling a throttle of the engine of the vehicle. The processor subsystem may selectively reduce the throttle based upon data received from the radar detector, the at least one sensor and the memory subsystem or may also count a total number of vehicle proximity alarms determined by the processor subsystem and selectively reduce the throttle based upon the total number of vehicle proximity alarms, as well. In yet another aspect thereof, the at least one sensor further includes a brake sensor for indicating whether a brake system of the vehicle is activated.

In other aspects thereof, the apparatus may be further provided with a fuel overinjection notification circuit for issuing a notification that excessive fuel is being supplied to the engine of the vehicle, an upshift notification circuit for issuing a notification that the engine of the vehicle is being operated at an excessive engine speed or a downshift notification circuit for issuing a notification that the engine of the vehicle is being operated at an insufficient engine speed. If a fuel overinjection notification circuit is provided, the apparatus includes a manifold pressure sensor and a throttle position sensor which also provide the processor subsystem with data used, together with a manifold pressure set point and prior levels for the sensors stored in the memory subsystem, to determine when to activate the fuel overinjection circuit. If an upshift notification circuit is provided, the apparatus includes an engine speed sensor which also provides the processor subsystem with data used, together with an RPM set point stored in the memory subsystem, to determine when to activate the upshift notification circuit. Finally, if a downshift notification circuit is provided, the processor subsystem determines when to activate the downshift notification circuit based upon the data received from the plurality of sensors.

In still another embodiment, the present invention is of an apparatus for optimizing operation of a vehicle which includes a radar detector for determining a distance separating the vehicle from an object in front of it, a plurality of sensors, including a road speed sensor, an engine speed sensor, a manifold pressure sensor and a throttle position sensor, which collectively monitor the operation of the vehicle, a processor subsystem, a memory subsystem, a fuel overinjection notification circuit for issuing notification that excessive fuel is being supplied to the engine of the vehicle and a vehicle proximity alarm circuit for issuing alarms if the vehicle is too close to the object. Based upon data received from the sensors, the processor subsystem determines when to activate the fuel overinjection circuit. Based upon data received from the radar detector, the sensors and the memory subsystem, the processor subsystem also determines when to activate the vehicle proximity alarm circuit.

In one aspect of this embodiment of the invention, the processor subsystem determines when road speed for the vehicle is increasing or decreasing, when throttle position for the vehicle is increasing or decreasing, compares manifold pressure to a manifold pressure set point stored in the memory subsystem, determines when manifold pressure for the vehicle is increasing or decreasing and determines when engine speed for the vehicle is increasing or decreasing. In this aspect, the processor subsystem activates the fuel overinjection notification circuit if both road speed and throttle position for the vehicle are increasing and manifold pressure for the vehicle is above the manifold pressure set point or if both throttle position and manifold pressure for the vehicle

5

are increasing and road speed and engine speed for the vehicle are decreasing.

In a further aspect thereof, the apparatus may also include an upshift notification circuit for issuing notifications that the engine of the vehicle is being operated at an excessive engine speed, the processor subsystem determining when to activate the upshift notification circuit based upon data received from the sensors. In a related aspect thereof, the processor subsystem determines when road speed for the vehicle is increasing, determines when throttle position for the vehicle is increasing, compares manifold pressure to a manifold pressure set point stored in the memory subsystem and compares engine speed to an RPM set point stored in the memory subsystem. In this aspect, the processor subsystem activates the upshift notification circuit if both road speed and throttle position for the vehicle are increasing, manifold pressure for the vehicle is at or below the manifold pressure set point and engine speed for the vehicle is at or above the RPM set point.

In still another aspect thereof, the apparatus may also include a downshift notification circuit for issuing a notification that the engine of the vehicle is being operated at an insufficient engine speed. In this aspect, the processor subsystem determines when to activate the downshift notification circuit based upon data received from the sensors. In a related aspect thereof, the processor subsystem determines when road speed for the vehicle is decreasing, determines when throttle position for the vehicle is increasing, determines when manifold pressure for the vehicle is increasing and determines when engine speed for the vehicle is decreasing. In this aspect, the processor subsystem activates the downshift notification circuit if both road speed and engine speed are decreasing and both throttle position and manifold pressure for the vehicle are increasing.

BRIEF DESCRIPTION OF THE DRAWINGS

The present invention may be better understood, and its numerous objects, features and advantages will become apparent to those skilled in the art by reference to the accompanying drawing, in which:

FIG. 1 is a block diagram of an apparatus for optimizing vehicle performance constructed in accordance with the teachings of the present invention; and

FIGS. 2A-B is a flow chart of a method for optimizing vehicle performance in accordance with the teachings of the present invention.

DETAILED DESCRIPTION

Referring first to FIG. 1, a system 10 for optimizing vehicle performance constructed in accordance with the teachings of the present invention will now be described in greater detail. The system 10 includes a processor subsystem 12, for example, a microprocessor, and a memory subsystem 14, for example, the memory subsystem 14 may include a nonvolatile random access memory (or "NVRAM"), coupled together by a bus 16 for bi-directional exchanges of address, data and control signals therebetween. The system 10 is installed in a vehicle (not shown) for which optimized performance and driver assist capabilities are desired. Although it is contemplated that the system 10 is suitable for use with any type vehicle, most commonly, the system 10 shall be installed in a truck.

Also coupled to the processor subsystem 12 are a series of sensors, each of which are periodically polled by the processor subsystem 12, to determine the respective states or

6

levels thereof. The sensors include a road speed sensor 18, an RPM sensor 20, a manifold pressure sensor 22, a throttle sensor 24, a windshield wiper sensor 30 and a brake sensor 32. The sensors are selected to be either state or level sensors, depending on whether the information to be collected thereby is a state, i.e., on/off or a level, for example, 35 mph. The road speed sensor 18 and the RPM sensor 20 are level sensors which respectively provide the processor subsystem 12 with signals which indicate the operating speed and engine speed for the vehicle. The road speed sensor 18 and the RPM sensor 20 may derive such information from any one of a variety of sources. For example, the road speed sensor 18 may be connected to receive the speed input signal transmitted to the vehicle's speedometer while the RPM sensor 20 may be connected to receive the RPM input signal to the vehicle's tachometer.

The manifold pressure sensor 22 is a level sensor which is positioned downstream of the throttle valve in the intake manifold of the vehicle to measure manifold pressure thereat. The throttle sensor 24 is a level sensor, attached to the throttle, which measures the extent to which the throttle is opened. The windshield wiper sensor 30 is a state sensor which determines whether the vehicle's windshield wipers are on or off. In alternate embodiments thereof, the windshield wiper sensor 30 may be electrically coupled to the on/off switch for the windshield wiper or to an output of the windshield wiper motor. Finally, the brake sensor 32 is a state sensor which determines whether the brakes of the vehicle have been engaged. For example, the brake sensor 32 may be electrically coupled to the brake system to detect the activation thereof.

Preferably, the memory subsystem 14 should include first and second registers 14a and 14b, each having sufficient bits for holding the state/level of each of the sensors 18, 20, 22, 24, 30 and 32. The first register 14a is used to hold the present state or level of each of the sensors 18, 20, 22, 24, 30 and 32 while the second register 14b is used to hold the prior state or level for each of the sensors 18, 20, 22, 24, 30 and 32. Each time the processor subsystem 12 writes the present state or level of the sensors 18, 20, 22, 24, 30 and 32 to the first register 14a, the prior contents of the first register 14a is written to the second register 14b which, in turn, discards the prior content thereof. The memory subsystem 14 is also used to hold information to be utilized by the processor subsystem 12 to determining whether to take corrective actions and/or issue notifications. Typically, such information is placed in the memory subsystem 14 while the system 10 is being initialized. The information includes one or more speed/distance tables which, when used in a manner which will be more fully described below in combination with data collected by the system 10, enable the processor subsystem 12 to determine if the vehicle is being operated unsafely and if corrective action is necessary. Speed/stopping distance table. The information also includes two pre-set threshold values—a manifold psi set point and an engine RPM set point. As will also be more fully described below, the processor subsystem 12 uses these threshold values to determine when to issue notifications as to recommended changes in vehicle operation which, when executed by the driver, will optimize vehicle operation. The speed/stopping distance table(s) are based upon National Safety Council guidelines, vary according to the class of the vehicle and provide the relationship between the speed at which a vehicle is travelling and the distance which the vehicle will require to come to a complete stop if travelling at that speed. The manifold psi set point and RPM set point are selected based upon the manufacturer's guidelines for

proper operation of the vehicle, vary based upon horsepower and engine size for the vehicle and represent thresholds above which the manifold pressure and engine rotation speed, respectively, for the vehicle should never exceed.

The system 10 also includes a throttle controller 26 capable of opening and/or closing the throttle, a radar detector 28 positioned to determine the distance separating the vehicle and an object in front of the vehicle, for example, a second vehicle travelling in the same direction, a series of circuits 34, 36, 38 and 40 for notifying the driver of the vehicle of recommended corrections in vehicle operation and alerting the driver to unsafe operating conditions and a power supply, for example a +12 v battery, for providing power to the energy-demanding components of the system 10. The circuits 34, 36, 38 and 40 include an upshift notification circuit 34 for notifying the driver that an upshift is recommended, a downshift notification circuit 36 for notifying the driver that a downshift is recommended, an overinjection notification circuit 38 for notifying the driver that too much fuel is being supplied to the vehicle and a vehicle proximity alarm circuit 40 for alerting the driver when an object in front of the vehicle is too close. The circuits 34, 36 and 38 may be configured to provide visual and/or audible notifications, for example, using lights and/or horns. For example, the upshift circuit 34, the downshift notification circuit 36 and the overinjection notification circuit 38 may each include a horn, or other tone generating device, from which an audible notification may be generated at a selected pitch. Preferably, each of the notification circuits 34, 36 and 38 may be configured to provide distinct audible notifications, for example, tones at distinct pitches, so that the driver may readily distinguish which of the notification circuits 34, 36 and 38 have been activated by the processor subsystem 12. The proximity alarm circuit 40 may include one or more visual and/or audible warning devices such as lights and/or horns. For example, the proximity alarm circuit 40 may include a warning light and a warning horn. If desired, the proximity alarm circuit may also include a display for displaying the speed of the object in the vehicle's path and/or the stopping distance in feet. The proximity alarm circuit 40 may be further equipped to provide audible indications of the speed of the object in the vehicle's path and/or the stopping distance in feet as well as selector circuitry for selecting both the information to be provided as well as the manner in which the information is to be conveyed.

Finally, the processor subsystem 12 is further provided with one or more mode select input lines which enable operator configuration of the operation of the system 10. For example, as described herein, the corrective operations consist of the combination of an automatic reduction of throttle and audio/visual alerts that the vehicle is being operated unsafely. It is specifically contemplated, however, that the system 10 include a mode select line for switching the system 10 between an "active" mode where both automatic throttle reduction and audio/visual alerts are generated and an "inactive" mode where only audio/visual alerts are generated.

Referring next to FIGS. 2A-B, a method for optimizing vehicle performance in accordance with the teachings of the present invention will now be described in greater detail. The method commences by powering up the processor subsystem 12, for example, by closing switch 42, thereby coupling the processor subsystem 12 to the power source 44 via line 43. Alternately, the processor subsystem 12 may be connected to the electrical system of the vehicle such that it will automatically power up when the vehicle is started. Of

course, any of the other devices which also form part of the system 10 and require power may also be coupled to the line 43. Appropriate voltage levels for the processor subsystem 12, as well as any additional power-demanding devices coupled to the power source 44, would be provided by voltage divider circuitry (not shown).

Once the system 10 is powered up, the method begins at step 50 by the processor subsystem 12 polling the road speed sensor 18, the RPM sensor 20, the manifold pressure sensor 22, the throttle sensor 24, the windshield wiper sensor 30 and the brake sensor 32 to determine their respective levels or states and places the acquired information in the first data register 14a. Of course, it should be noted, however, that polling of the sensors by the processor subsystem 12 is but one technique by which the processor subsystem 12 may acquire the requisite information. Alternately, each sensor 20, 22, 24, 30 and 32 may periodically place its level or state in one or more bits of the first data register 14a. The processor subsystem 12 would then acquire information by checking the contents of the first data register 14a at selected time intervals.

Proceeding to step 52, the processor subsystem 12 examines the contents of the first data register 14a to determine the operating speed of the vehicle. If the processor subsystem 12 determines that the vehicle is stationary, i.e., the operating speed of the vehicle is zero, the processor subsystem 12 will return to step 50 where the road speed sensor 18, the RPM sensor 20, the manifold pressure sensor 22, the throttle sensor 24, the windshield wiper sensor 30 and the brake sensor 32 will be repeatedly polled until an operating speed greater than zero is detected at step 52. While polling may be conducted at a variety of time intervals, a polling period of one second appears suitable for the uses contemplated herein.

Returning to step 52, once an operating speed greater than zero is detected by the processor subsystem 12, the method proceeds to step 54 where the processor subsystem 12 again polls the operating speed sensor 18, the RPM sensor 20, the manifold pressure sensor 22, the throttle sensor 24, the windshield wiper sensor 30 and the brake sensor 32, to determine their respective levels or states and places the acquired information in the first data register 14a. In turn, the contents of the first data register 14a is placed in the second data register 14b.

Proceeding now to step 56, from the polled value of the road speed sensor 18, the processor subsystem 12 determines whether the vehicle is travelling faster than 20 mph. If the operating speed of the vehicle is less than 20 mph, the method returns to step 54 where the sensors 18, 20, 22, 24, 30 and 32 will be repeatedly polled and the value of the road speed sensor examined until the processor subsystem 12 determines that the vehicle is travelling faster than 20 mph. If, however, the processor subsystem 12 determines that the vehicle is travelling faster than 20 mph, the method proceeds to step 58 where the processor subsystem 12 then determines if the vehicle is travelling faster than 50 mph, again by checking the contents of the first data register 14a.

Past this juncture, the method of the present invention will proceed through a series of steps designed to optimize vehicle operation. However, prior to optimizing vehicle operation, the processor subsystem 12 will determine if the vehicle is being operated unsafely. If so, the processor subsystem 12 will initiate corrective operations before commencing vehicle operation optimization. More specifically, if the processor subsystem 12 determines at step 58 that the vehicle is travelling at a speed greater than 50 mph, the



processor subsystem 12 will initiate a process by which it will determine whether the vehicle is being operated unsafely.

The processor subsystem 12 determines that the vehicle is being operated unsafely if the speed of the vehicle is such that the stopping distance for the vehicle *d* is greater than the distance separating the vehicle from an object, for example, a second vehicle, in its path. In order to make this determination, the processor subsystem 12 is provided access to at least one speed/distance table. For example, stored at location 14c within the memory subsystem 14 is a first speed/stopping distance table. The speed/stopping distance table contains the relationship between vehicle speed and stopping distance. Thus, for any given speed, the processor subsystem 12 may look-up the stopping distance for that speed. Preferably, the memory subsystem 14 should contain multiple speed/stopping distance tables so that differences in road conditions and/or vehicle class may be taken into account. For example, the speed/stopping distance table stored at location 14c may be a speed/stopping distance table for dry roads while a speed/stopping distance table for wet roads may be stored at location 14d. If desired, the memory subsystem 14 may also contain additional speed/stopping distance tables for other vehicle classes. If such additional tables were provided, however, the disclosed method would need to be modified to include additional steps in which the operator provides the vehicle's class and the processor subsystem 12 selects the appropriate speed/stopping distance tables for the indicated class of vehicle.

To make the aforementioned determination of unsafe vehicle operation, the method proceeds to step 60 where the processor subsystem 12 sets the value of the expression ALARM to 1. The method then proceeds to step 62 where the processor subsystem 12 examines the state of the wiper sensor 32 and selects a speed/stopping distance table based upon the state of the wiper sensor 32. If the state of the wiper sensor 32 indicates that the windshield wiper is off, the processor subsystem 12 concludes that the vehicle is being operated in dry conditions and selects the speed/stopping distance table stored at the location 14c of the memory subsystem 14. If, however, the state of the wiper sensor 32 indicates that the windshield wiper is on, the processor subsystem 12 concludes that the vehicle is being operated in wet conditions and selects the speed/stopping distance table stored at the location 14d of the memory subsystem 14. From the selected speed/stopping distance table 14c or 14d, the processor subsystem 12 then retrieves the stopping distance for the speed at which the vehicle is travelling.

Continuing on to step 64, the processor subsystem 12 determines the distance of the vehicle to an object in its path, i.e., a second vehicle travelling in front of the vehicle and in the same direction. To do so, the processor subsystem 12 instructs the radar device 28 to determine the distance between the vehicle and the second vehicle in front of it. Upon determining the distance separating the two vehicles, the radar device 28 transmits the determined separation distance to the processor subsystem 12. At step 66, the processor subsystem 12 determines if the two vehicles are separated by a safe distance. To do so, the processor subsystem 12 compares the distance separating the two vehicles to the retrieved stopping distance for the vehicle. If the determined distance separating the two vehicles is greater than the retrieved stopping distance for the vehicle, the processor subsystem 12 determines that the vehicle is being operated safely. If, however, the determined distance separating the two vehicles is less than the retrieved stopping distance, the processor subsystem 12 determines that the vehicle is being operated unsafely.

If the processor subsystem 12 determines at step 66 that the vehicle is being operated unsafely, the processor subsystem 12 initiates appropriate corrective action. At step 68, the processor subsystem 12 determines whether the vehicle brake is on by examining the state of the brake sensor 32. If the brake is on, the processor subsystem 12 concludes that the driver is taking corrective action and that further corrective action is not necessary. If, however, the processor subsystem 12 determines that the vehicle brake is off, the method proceeds to step 70 where the processor subsystem examines the level of the vehicle speed sensor to determine if the speed of the vehicle is less than 35 mph. If the speed of the vehicle is less than 30 mph, the processor subsystem 12 concludes that no further corrective action will be taken.

If, however, the processor subsystem 12 determines that the speed of the vehicle is greater than 35 mph, the method proceeds to step 72 where the processor subsystem 12 selects a throttle reduction value based upon the value of the expression ALARM. Generally, the severity of the corrective action to be initiated by the processor subsystem 12 is varied depending on the number of times that corrective action has been taken and, more specifically, the severity of the selective corrective action increases with the value of the expression ALARM. For example, in the embodiment of the invention disclosed herein, if ALARM=1, a 25% throttle reduction is selected, if ALARM=2, a 50 throttle reduction is selected and, if ALARM $\geq$ 3, a 100% throttle reduction is selected. By reducing the throttle, the transport of fuel to the engine is retarded and the vehicle will begin to decelerate.

Continuing on to step 74, the processor subsystem 12 determines the extent to which the throttle is open using the throttle level provided by the throttle sensor 24 and, using throttle control 26, reduces the throttle by the selected percentage. At step 76, the processor subsystem 12 selects an alert mode, again based upon the value of the expression ALARM. As before, the severity of the alert mode may increase with the value of ALARM. For example, when ALARM=1, a warning light may be activated in a flash mode while, when  $2 \leq \text{ALARM} \leq 3$ , an audible alert which lasts for a first selected time period, for example, two seconds, may be activated in combination with the flashing warning light and when ALARM $\geq$ 4, an audible alert which lasts for a second, longer, time period, for example, six seconds, may be activated in combination with the flashing light.

Proceeding to step 78, the processor subsystem 12 issues an alert to the operator of the vehicle in accordance with the selected alert mode. To do so, the processor subsystem 12 activates vehicle proximity alarm circuit 40 in accordance with the selected alert mode. After issuing the alert at step 78, the method proceeds to step 80 where the processor subsystem 12 waits a selected period before taking any further action. The wait period is intended to provide sufficient time to see if the previously initiated corrective action eliminates the hazardous condition. As disclosed herein, a wait period of 10 seconds is suitable. However, wait periods of various lengths should be equally suitable for the uses contemplated herein.

Upon expiration of the wait period, the value of the expression ALARM is incremented by one at step 82 and, at step 84, the processor subsystem 12 again polls the operating speed sensor 18, the RPM sensor 20, the manifold pressure sensor 22, the throttle sensor 24, the windshield wiper sensor 30 and the brake sensor 32, to determine their respective levels or states and places the acquired information in the first data register 14a. The method returns to step 64 where the distance between the vehicle and the object in its path is

11

re-determined. The processor subsystem 12 continues to take corrective action until it determines that the vehicle is no longer being operated in a hazardous manner. More specifically, the processor subsystem 12 will conclude that the hazardous condition has been corrected when it either: determines at step 66 that the distance separating the vehicle and the object is within the stopping distance for the vehicle, determines at step 68 that the vehicle brake is on or determines at step 70 that the speed of the vehicle is less than 35 mph. Upon making such a determination, the method proceeds to step 86 where the processor subsystem 12 deactivates the vehicle proximity alarm circuit 40 to turn off the flashing light.

The method of optimizing vehicle operation in accordance with the teachings of the present invention will now be described in greater detail. Returning now to step 58, if the processor subsystem 12 determines that the vehicle is travelling slower than 50 mph, or if the processor subsystem 12 determines at step 66 that the distance separating the vehicle and the object is within the stopping distance for the vehicle or if the processor subsystem 12 determines at step 68 that the vehicle brake is on or if the processor subsystem 12 determines at step 70 that the speed of the vehicle is less than 35 mph, the method proceeds, after deactivation of the vehicle proximity alarm circuit 40, to step 88 where the processor subsystem 12 determines if the road speed of the vehicle is changing. To do so, the processor subsystem 12 compares the speed of the vehicle maintained in the first register 14a to the speed of the vehicle maintained in the second register 14b.

If the vehicle speed maintained in the first register 14a is greater than the vehicle speed maintained in the second register 14b, the vehicle is accelerating. If so, the method continues to step 90 where the processor subsystem 12 determines if the throttle position is increasing. To do so, the processor subsystem 12 compares the throttle level, i.e., the extent to which the throttled is opened, maintained in the first register 14a to the throttle level maintained in the second register 14b. If the throttle position has not increased, the processor subsystem 12 determines that, since the vehicle is accelerating but fuel consumption is not increasing, no modification of vehicle operation is necessary. Accordingly, the method returns to step 54 for a next polling of the sensors 18, 20, 22, 24, 30 and 32.

If, however, the processor subsystem 12 determines at step 90 that the throttle position has increased, the method proceeds to step 92 where the processor subsystem 12 determines if the manifold pressure level maintained in the first register 14a has exceeded the manifold pressure set point for the vehicle. If the vehicle's road speed and throttle position are increasing and the manifold pressure for the vehicle is at or below the manifold pressure set point, the processor subsystem 12 proceeds to step 93 where the sensors 18, 20, 22, 24, 30 and 32 are again polled and on to step 94 where the processor subsystem 12 compares the engine speed level maintained in the first register 14a to the RPM set point stored in the memory subsystem 14 to determine if the engine speed has reached the RPM set point. If the engine speed has not reached the RPM set point, the method returns to step 93 where the sensors 18, 20, 22, 24, 30 and 32 are repeatedly polled until the processor subsystem 12 determines that the engine speed has reached the RPM set point. Once the engine speed has reached the RPM set point, the processor subsystem 12 determines that the vehicle needs to be upshifted and, proceeding to step 95, the processor subsystem 12 will activate the upshift notification circuit 34 to issue an audible alert for a selected time period,

12

for example, 6 seconds, thereby notifying the driver that, in order to optimize vehicle operation, an upshift should be performed. The method then returns to step 54 for a next polling of the sensors 18, 20, 22, 24, 30 and 32.

Returning to step 92, if the vehicle's road speed and throttle position are increasing and the manifold pressure for the vehicle is above the manifold pressure set point, the processor subsystem 12 determines that too much fuel is being provided to the engine and proceeding to step 96, the processor subsystem 12 will activate the overinjection notification circuit 38 to issue an audible alert for a selected time period, for example, 6 seconds, thereby notifying the driver that, in order to optimize vehicle operation, the amount of fuel being supplied to the engine should be reduced. The method then returns to step 54 for a next polling of the sensors 18, 20, 22, 24, 30 and 32.

Returning to step 88, if the processor subsystem 12 determines, when comparing the speed of the vehicle maintained in the first register 14a to the speed of the vehicle maintained in the second register 14b, that the speed of the vehicle is decreasing, the method proceeds to step 98 where the processor subsystem 12 determines if the throttle position is changing. To do so, the processor subsystem 12 compares the throttle level, i.e., the extent to which the throttled is opened, maintained in the first register 14a to the throttle level maintained in the second register 14b. If the throttle position has either remained constant or decreased, the processor subsystem 12 determines that, since fuel consumption is either constant or reduced, no modification of vehicle operation is necessary. Accordingly, the method returns to step 54 for a next polling of the sensors 18, 20, 22, 24, 30 and 32.

If, however, the processor subsystem 12 determines at step 98 that the throttle position has increased, the method proceeds to step 100 where the processor subsystem 12 determines if the manifold pressure is increasing. To do so, the processor subsystem 12 compares the manifold pressure level maintained in the first register 14a to the manifold pressure level maintained in the second register 14b. If the manifold pressure level maintained in the first register 14a is less than the manifold pressure level maintained in the second register 14b, the processor subsystem 12 determines that, since manifold pressure is decreasing, no modification of vehicle operation is necessary. Accordingly, the method returns to step 54 for a next polling of the sensors 18, 20, 22, 24, 30 and 32.

If, however, the manifold pressure level maintained in the first register 14a is greater than the manifold pressure level maintained in the second register 14b, the processor subsystem 12 determines that the manifold pressure for the vehicle is increasing and the method proceeds to step 102 where the processor subsystem 12 determines if the engine speed is increasing. To do so, the processor subsystem 12 compares the engine speed level maintained in the first register 14a to the engine speed level maintained in the second register 14b. If the engine speed level maintained in the first register 14a is less than the engine speed level maintained in the second register 14b, the processor subsystem 12 determines that, since engine speed is increasing, no modification of vehicle operation is necessary. Accordingly, the method returns to step 54 for a next polling of the sensors 18, 20, 22, 24, 30 and 32.

If, however, the engine speed level maintained in the first register 14a is less than the engine speed level maintained in the second register 14b, the processor subsystem 12 determines that, since the manifold pressure is increasing while

## 13

the engine speed is decreasing, too much fuel is being supplied to the engine. Accordingly, at step 104, the processor subsystem 12 activates the overinjection notification circuit 38 to issue an audible alert for a selected time period, for example, 6 seconds, thereby notifying the driver that, in order to optimize vehicle operation, the amount of fuel being supplied to the engine should be reduced.

Proceeding on to step 106, the sensors 18, 20, 22 24, 30 and 32 are again polled and, at step 108, the processor subsystem 12 determines if the engine speed is decreasing, again by comparing the engine speed level maintained in the first and second registers 14a and 14b. If the engine speed has not decreased, the method returns to step 104 where the processor subsystem 12 again activates the overinjection notification circuit 38 to issue another audible alert notifying the driver that, in order to optimize vehicle operation, the amount of fuel being supplied to the engine should be reduced. Thus, the driver will be repeatedly notified of the overinjection condition until the processor subsystem 12 determines, at step 108, that the engine speed is decreasing. The method will then proceed to step 110 where, since the processor subsystem 12 has determined that, since the engine speed is decreasing, the vehicle should be downshifted. Accordingly, at step 110, the processor subsystem 12 activates the downshift notification circuit 36 to issue an audible alert for a selected time period, for example, 6 seconds, thereby notifying the driver that, in order to optimize vehicle operation, the vehicle should be downshifted. The method then returns to step 54 for a next polling of the sensors 18, 20, 22 24, 30 and 32. The method will repeatedly loop through the aforementioned process to continuously determine if the vehicle is being operated unsafely, take appropriate corrective action and to provide notifications to the driver as to how operation of the vehicle may be optimized until the processor subsystem 12 is powered down or the vehicle is turned off.

Thus, there has been described and illustrated herein, an apparatus for optimizing vehicle operation which combines both operator notifications of recommended corrections in vehicle operation with automatic modification of vehicle operation under certain circumstances. By incorporating the disclosed apparatus in a vehicle, not only will certain hazardous operations of the vehicle be prevented but also the driver will be advised of certain actions which will enable the vehicle to be operated with greater fuel efficiency. However, those skilled in the art will recognize that many modifications and variations besides those specifically mentioned herein may be made without departing substantially from the concept of the present invention. Accordingly, it should be clearly understood that the form of the invention described herein is exemplary only and is not intended as a limitation on the scope of the invention.

What is claimed is:

1. Apparatus for optimizing operation of a vehicle, comprising:
  - a plurality of sensors coupled to a vehicle having an engine, said plurality of sensors, which collectively monitor operation of said vehicle, including a road speed sensor, an engine speed sensor, a manifold pressure sensor and a throttle position sensor;
  - a processor subsystem, coupled to each one of said plurality of sensors, to receive data therefrom;
  - a memory subsystem, coupled to said processor subsystem, said memory subsystem storing therein a manifold pressure set point, an RPM set point, and present and prior levels for each one of said plurality of sensors;

## 14

- a fuel overinjection notification circuit coupled to said processor subsystem, said fuel overinjection notification circuit issuing a notification that excessive fuel is being supplied to said engine of said vehicle;
  - an upshift notification circuit coupled to said processor subsystem, said upshift notification circuit issuing a notification that said engine of said vehicle is being operated at an excessive speed;
  - said processor subsystem determining, based upon data received from said plurality of sensors, when to activate said fuel overinjection circuit and when to activate said upshift notification circuit.
2. Apparatus for optimizing operation of a vehicle according to claim 1 wherein said processor subsystem further comprises:
    - means for determining when road speed for said vehicle is increasing;
    - means for determining when throttle position for said vehicle is increasing; and
    - means for comparing manifold pressure to said manifold pressure set point;
 said processor subsystem activating said fuel overinjection notification circuit if both road speed and throttle position for said vehicle are increasing and manifold pressure for said vehicle is above said manifold pressure set point.
  3. Apparatus for optimizing operation of a vehicle according to claim 1 wherein said fuel overinjection circuit further comprises a horn for issuing a tone for a preselected time period.
  4. Apparatus for optimizing operation of a vehicle according to claim 1 wherein said processor subsystem further comprises:
    - means for determining when road speed for said vehicle is decreasing;
    - means for determining when throttle position for said vehicle is increasing;
    - means for determining when manifold pressure for said vehicle is increasing; and
    - means for determining when engine speed for said vehicle is decreasing;
 said processor subsystem activating said fuel overinjection notification circuit if both throttle position and manifold pressure for said vehicle are increasing and road speed and engine speed for said vehicle are decreasing.
  5. Apparatus for optimizing operation of a vehicle according to claim 1 wherein said processor subsystem further comprises:
    - means for determining when road speed for said vehicle is increasing;
    - means for determining when throttle position for said vehicle is increasing;
    - means for comparing manifold pressure to said manifold pressure set point; and
    - means for comparing engine speed to said RPM set point;
 said processor subsystem activating said upshift notification circuit if both road speed and throttle position for said vehicle are increasing, manifold pressure for said vehicle is at or below said manifold pressure set point and engine speed for said vehicle is at or above said RPM set point.
  6. Apparatus for optimizing operation of a vehicle according to claim 1 wherein said upshift notification circuit further comprises a horn for issuing a tone for a preselected time period.

15

- 7. Apparatus for optimizing operation of a vehicle, comprising:
  - a plurality of sensors coupled to a vehicle having an engine, said plurality of sensors, which collectively monitor operation of said vehicle, including a road speed sensor, a manifold pressure sensor and a throttle position sensor;
  - a processor subsystem, coupled to each one of said plurality of sensors, to receive data therefrom;
  - a memory subsystem, coupled to said processor subsystem, said memory subsystem storing therein a manifold pressure set point and present and prior levels for each one of said plurality of sensors;
  - a fuel overinjection notification circuit coupled to said processor subsystem, said fuel overinjection notification circuit issuing a notification that excessive fuel is being supplied to said engine of said vehicle;
  - a downshift notification circuit coupled to said processor subsystem, said downshift notification circuit issuing a notification that said engine of said vehicle is being operated at an insufficient engine speed; and
  - said processor subsystem determining, based upon data received from said plurality of sensors, when to activate said fuel overinjection circuit and when to activate said downshift notification circuit.
- 8. Apparatus for optimizing operation of a vehicle according to claim 7 wherein said processor subsystem further comprises:
  - means for determining when road speed for said vehicle is increasing;
  - means for determining when throttle position for said vehicle is increasing; and
  - means for comparing manifold pressure to said manifold pressure set point;
  - said processor subsystem activating said fuel overinjection notification circuit if both road speed and throttle position for said vehicle are increasing and manifold pressure for said vehicle is above said manifold pressure set point.
- 9. Apparatus for optimizing operation of a vehicle according to claim 7 wherein said fuel overinjection circuit further comprises a horn for issuing a tone for a preselected time period.
- 10. Apparatus for optimizing operation of a vehicle according to claim 7 wherein said processor subsystem further comprises:
  - means for determining when road speed for said vehicle is decreasing;
  - means for determining when throttle position for said vehicle is increasing;
  - means for determining when manifold pressure for said vehicle is increasing; and
  - means for determining when engine speed for said vehicle is decreasing;
  - said processor subsystem activating said downshift notification circuit if both road speed and engine speed are decreasing and both throttle position and manifold pressure for said vehicle are increasing.
- 11. Apparatus for optimizing operation of a vehicle according to claim 10 wherein said downshift notification circuit further comprises a horn for issuing a tone for a preselected time period.
- 12. Apparatus for optimizing operation of a vehicle according to claim 7 wherein said processor subsystem further comprises:

16

- means for determining when road speed for said vehicle is decreasing;
- means for determining when throttle position for said vehicle is increasing;
- means for determining when manifold pressure for said vehicle is increasing; and
- means for determining when engine speed for said vehicle is decreasing;
- said processor subsystem activating said fuel overinjection notification circuit if both throttle position and manifold pressure for said vehicle are increasing and road speed and engine speed for said vehicle are decreasing.
- 13. Apparatus for optimizing operation of a vehicle, comprising:
  - a plurality of sensors coupled to a vehicle having an engine, said plurality of sensors, which collectively monitor operation of said vehicle, including a road speed sensor, an engine speed sensor, a manifold pressure sensor and a throttle position sensor;
  - a processor subsystem, coupled to each one of said plurality of sensors, to receive data therefrom;
  - a memory subsystem, coupled to said processor subsystem, said memory subsystem storing therein a manifold pressure set point, an engine speed set point and present and prior levels for each one of said plurality of sensors;
  - a fuel overinjection notification circuit coupled to said processor subsystem, said fuel overinjection notification circuit issuing a notification that excessive fuel is being supplied to said engine of said vehicle;
  - an upshift notification circuit coupled to said processor subsystem, said upshift notification circuit issuing a notification that said engine of said vehicle is being operated at an excessive engine speed;
  - a downshift notification circuit coupled to said processor subsystem, said downshift notification circuit issuing a notification that said engine of said vehicle is being operated at an insufficient engine speed;
  - said processor subsystem determining, based upon data received from said plurality of sensors, when to activate said fuel overinjection circuit, said upshift notification circuit and said downshift notification circuit.
- 14. Apparatus for optimizing operation of a vehicle according to claim 13 wherein:
  - said fuel overinjection circuit further comprises a first horn for issuing a first tone for a first preselected time period;
  - said upshift notification circuit further comprises a second horn for issuing a second tone for a second preselected time period; and
  - said downshift notification circuit further comprises a third horn for issuing a third tone for a third preselected time period.
- 15. Apparatus for optimizing vehicle performance according to claim 13 wherein said processor subsystem further comprises:
  - means for determining when road speed for said vehicle is increasing or decreasing
  - means for determining when throttle position for said vehicle is increasing;
  - means for comparing manifold pressure to said manifold pressure set point;
  - means for comparing engine speed to said RPM set point;

17

means for determining when manifold pressure is increasing; and  
 means for determining when engine speed is increasing or decreasing;  
 said processor subsystem activating said fuel overinjection notification circuit if both road speed and throttle position for said vehicle are increasing and manifold pressure for said vehicle is above said manifold pressure set or if both throttle position and manifold pressure for said vehicle are increasing and road speed and engine speed for said vehicle are decreasing;  
 said processor subsystem activating said upshift notification circuit if both road speed and throttle position for said vehicle are increasing, manifold pressure for said vehicle is at or below said manifold pressure set point and engine speed for said vehicle is at or above said RPM set point; and  
 said processor subsystem activating said downshift notification circuit if both road speed and engine speed are decreasing and both throttle position and manifold pressure for said vehicle are increasing.

16. Apparatus for optimizing operation of a vehicle according to claim 15 wherein:  
 said fuel overinjection circuit further comprises a first horn for issuing a first tone for a first preselected time period;  
 said upshift notification circuit further comprises a second horn for issuing a second tone for a second preselected time period; and  
 said downshift notification circuit further comprises a third horn for issuing a third tone for a third preselected time period.

17. Apparatus for optimizing operation of a vehicle, comprising:  
 a radar detector, said radar detector determining a distance separating a vehicle having an engine and an object in front of said vehicle;  
 at least one sensor coupled to said vehicle for monitoring operation thereof, said at least one sensor including a road speed sensor, a manifold pressure sensor, a throttle position sensor and an engine speed sensor;  
 a processor subsystem, coupled to said radar detector and said at least one sensor, to receive data therefrom;  
 a memory subsystem, coupled to said processor subsystem, said memory subsystem storing a first vehicle speed/stopping distance table, a manifold pressure set point, an RPM set point, a present level for each one of said at least one sensor and a prior level for each one of said at least one sensor;  
 a vehicle proximity alarm circuit coupled to said processor subsystem, said vehicle proximity alarm circuit issuing an alarm that said vehicle is too close to said object;  
 a fuel overinjection circuit coupled to said processor subsystem, said fuel overinjection circuit issuing a notification that excessive fuel is being supplied to said engine of said vehicle;  
 an upshift notification circuit coupled to said processor subsystem, said upshift notification circuit issuing a notification that said engine of said vehicle is being operated at an excessive speed;  
 said processor subsystem determining, based upon data received from said radar detector, said at least one sensor and said memory subsystem, when to activate

18

said vehicle proximity alarm circuit, when to activate said fuel overinjection circuit, and when to activate said upshift notification circuit.

18. Apparatus for optimizing operation of a vehicle according to claim 17 wherein:  
 said at least one sensor further includes a windshield wiper sensor for indicating whether a windshield wiper of said vehicle is activated; and  
 said memory subsystem further storing a second vehicle speed/stopping distance table.

19. Apparatus for optimizing operation of a vehicle according to claim 17 and further comprising:  
 a throttle controller for controlling a throttle of said engine of said vehicle; and  
 said processor subsystem selectively reducing said throttle based upon data received from said radar detector, said at least one sensor and said memory subsystem.

20. Apparatus for optimizing operation of a vehicle according to claim 19 wherein said at least one sensor further includes a brake sensor for indicating whether a brake system of said vehicle is activated.

21. Apparatus for optimizing operation of a vehicle according to claim 19 wherein said processor subsystem further comprises:  
 means for counting a total number of vehicle proximity alarms determined by said processor subsystem;  
 means for selectively reducing said throttle based upon said total number of vehicle proximity alarms.

22. Apparatus for optimizing operation of a vehicle according to claim 17 and further comprising:  
 a downshift notification circuit coupled to said processor subsystem, said downshift notification circuit issuing a notification that said engine of said vehicle is being operated at an insufficient engine speed; and  
 said processor subsystem determining, based upon data received from said plurality of sensors, when to activate said downshift notification circuit.

23. Apparatus for optimizing operation of a vehicle, comprising:  
 a radar detector, said radar detector determining a distance separating a vehicle having an engine and an object in front of said vehicle;  
 a plurality of sensors coupled to a vehicle having an engine, said plurality of sensors, which collectively monitor operation of said vehicle, including a road speed sensor, and engine speed sensor, a manifold pressure sensor and a throttle position sensor;  
 a processor subsystem, coupled to said radar detector and each one of said plurality of sensors, to receive data therefrom;  
 a memory subsystem, coupled to said processor subsystem, said memory subsystem storing therein a first vehicle speed/stopping distance table, a manifold pressure set point, an RPM set point, and present and prior levels for each one of said plurality of sensors;  
 a fuel overinjection notification circuit coupled to said processor subsystem, said fuel overinjection notification circuit issuing a notification that excessive fuel is being supplied to said engine of said vehicle;  
 an upshift notification circuit coupled to said processor subsystem, said upshift notification circuit issuing a notification that said engine of said vehicle is being operated at an excessive engine speed;  
 said processor subsystem determining, based upon data received from said plurality of sensors, when to activate

19

vate said fuel overinjection circuit and when to activate said upshift notification circuit;

a vehicle proximity alarm circuit coupled to said processor subsystem, said vehicle proximity alarm circuit issuing an alarm that said vehicle is too close to said object;

said processor subsystem determining, based upon data received from said radar detector, said at least one sensor and said memory subsystem, when to activate said vehicle proximity alarm circuit.

24. Apparatus for optimizing operation of a vehicle according to claim 23 wherein said processor subsystem further comprises:

- means for determining when road speed for said vehicle is increasing or decreasing;
- means for determining when throttle position for said vehicle is increasing or decreasing; and
- means for comparing manifold pressure to said manifold pressure set point;
- means for determining when manifold pressure for said vehicle is increasing or decreasing; and
- means for determining when engine speed for said vehicle is increasing or decreasing;

said processor subsystem activating said fuel overinjection notification circuit if both road speed and throttle position for said vehicle are increasing and manifold pressure for said vehicle is above said manifold pressure set point or if both throttle position and manifold pressure for said vehicle are increasing and road speed and engine speed for said vehicle are decreasing.

25. Apparatus for optimizing operation of a vehicle according to claim 23 wherein said processor subsystem further comprises:

- means for determining when road speed for said vehicle is increasing;
- means for determining when throttle position for said vehicle is increasing;
- means for comparing manifold pressure to said manifold pressure set point; and
- means for comparing engine speed to said RPM set point;

said processor subsystem activating said upshift notification circuit if both road speed and throttle position for said vehicle are increasing, manifold pressure for said vehicle is at or below said manifold pressure set point and engine speed for said vehicle is at or above said RPM set point.

26. Apparatus for optimizing operation of a vehicle, comprising:

- a radar detector, said radar detector determining a distance separating a vehicle having an engine and an object in front of said vehicle;
- a plurality of sensors coupled to a vehicle having an engine, said plurality of sensors, which collectively monitor operation of said vehicle, including a road speed sensor, and engine speed sensor, a manifold pressure sensor and a throttle position sensor;
- a processor subsystem, coupled to said radar detector and each one of said plurality of sensors, to receive data therefrom;
- a memory subsystem, coupled to said processor subsystem, said memory subsystem storing therein a first vehicle speed/stopping distance table, a manifold pressure set point, RPM set point, and present and prior levels for each one of said plurality of sensors;

20

a fuel overinjection notification circuit coupled to said processor subsystem, said fuel overinjection notification circuit issuing a notification that excessive fuel is being supplied to said engine of said vehicle;

a downshift notification circuit coupled to said processor subsystem, said downshift notification circuit issuing a notification that said engine of said vehicle is being operated at an insufficient engine speed;

said processor subsystem determining, based upon data received from said plurality of sensors, when to activate said fuel overinjection circuit and when to activate said downshift notification circuit;

a vehicle proximity alarm circuit coupled to said processor subsystem, said vehicle proximity alarm circuit issuing an alarm that said vehicle is too close to said object;

said processor subsystem determining, based upon data received from said radar detector, said at least one sensor and said memory subsystem, when to activate said vehicle proximity alarm circuit.

27. Apparatus for optimizing operation of a vehicle according to claim 26 wherein said processor subsystem further comprises:

- means for determining when road speed for said vehicle is decreasing;
- means for determining when throttle position for said vehicle is increasing;
- means for determining when manifold pressure for said vehicle is increasing; and
- means for determining when engine speed for said vehicle is decreasing;

said processor subsystem activating said downshift notification circuit if both road speed and engine speed are decreasing and both throttle position and manifold pressure for said vehicle are increasing.

28. Apparatus for optimizing operation of a vehicle, comprising:

- a plurality of sensors coupled to a vehicle having an engine, said plurality of sensors, which collectively monitor operation of said vehicle, including a road speed sensor, a manifold pressure sensor and a throttle position sensor;
- a processor subsystem, coupled to each one of said plurality of sensors, to receive data therefrom;
- a fuel overinjection notification circuit coupled to said processor subsystem, said fuel overinjection notification circuit issuing a notification that excessive fuel is being supplied to said engine of said vehicle;

said processor subsystem determining whether to activate said fuel overinjection notification sensor based upon data received from said road speed sensor, said throttle position sensor and said manifold pressure sensor.

29. Apparatus according to claim 28 and further comprising:

- a memory subsystem, coupled to said processor subsystem, said memory subsystem maintaining a manifold pressure set point;

said processor subsystem activating said fuel overinjection notification circuit upon determining that:

- (1) based upon data received from said road speed sensor, road speed of said vehicle is increasing;
- (2) based upon data received from said throttle position sensor, throttle position for said vehicle is increasing;

and

21

(3) based upon data received from said manifold pressure sensor, manifold pressure for said vehicle exceeds said manifold pressure set point.

30. Apparatus according to claim 28, wherein: said plurality of sensors coupled to said vehicle further include an engine speed sensor;

said processor subsystem activating said fuel overinjection notification circuit upon determining that:

(1) based upon data received from said road speed sensor, road speed of said vehicle is decreasing;

(2) based upon data received from said throttle position sensor, throttle position for said vehicle is increasing;

(3) based upon data received from said manifold pressure sensor, manifold pressure for said vehicle is increasing; and

(4) based upon data received from said engine speed sensor, engine speed for said vehicle is decreasing.

31. Apparatus for optimizing operation of a vehicle, comprising:

a radar detector, said radar detector determining a distance separating a vehicle having an engine and an object in front of said vehicle;

at least one sensor coupled to said vehicle for monitoring operation thereof, said at least one sensor including a road speed sensor;

a processor subsystem, coupled to said radar detector and said at least one sensor, to receive data therefrom;

a memory subsystem, coupled to said processor subsystem, said memory subsystem storing a first vehicle speed/stopping distance table;

a vehicle proximity alarm circuit coupled to said processor subsystem, said vehicle proximity alarm circuit issuing an alarm that said vehicle is too close to said object;

22

said processor subsystem determining whether to activate said vehicle proximity alarm circuit based upon separation distance data received from said radar detector, vehicle speed data received from said road speed sensor and said first vehicle speed/stopping distance table stored in said memory subsystem.

32. Apparatus for optimizing operation of a vehicle according to claim 31 wherein:

said at least one sensor further includes a windshield wiper sensor for indicating whether a windshield wiper of said vehicle is activated; and

said memory subsystem further storing a second vehicle speed/stopping distance table;

if said windshield wiper sensor indicates that said windshield wiper is deactivated, said processor subsystem determining whether to activate said vehicle proximity alarm circuit based upon data received from said radar detector, said road speed sensor and said first vehicle speed/stopping distance table stored in said memory subsystem;

if said windshield wiper sensor indicates that said windshield wiper is activated, said processor subsystem determining whether to activate said vehicle proximity alarm circuit based upon data received from said radar detector, said road speed sensor and said second vehicle speed/stopping distance table stored in said memory subsystem.

\* \* \* \* \*

## **EXHIBIT 2**





4. On information and belief, Defendant Audi of America, LLC is a corporation organized under the laws of the state of Delaware with an office and principal place of business located at 220 Ferdinand Porsche Dr., Herndon, VA 20171.

5. Audi advertises, markets, and distributes automobiles under the Audi brand throughout the United States.

#### **JURISDICTION AND VENUE**

6. This Court has jurisdiction over the subject matter of this action pursuant to 28 U.S.C. §§ 1331 and 1338(a).

7. This Court has personal jurisdiction over Audi because Audi has committed, and continues to commit, acts of patent infringement in Illinois, including in this judicial district, and otherwise transacts business in the state of Illinois, including in this district.

8. Venue is proper in this District under 28 U.S.C. §§ 1391(b)-(d) and 1400(b) because Audi is subject to personal jurisdiction in this judicial district and has committed, and continues to commit, acts of patent infringement giving rise to the claims alleged herein within this judicial district.

#### **THE PATENT-IN-SUIT**

9. On September 21, 1999, U.S. Patent No. 5,954,781 (“the ‘781 Patent”), entitled “METHOD AND APPARATUS FOR OPTIMIZING VEHICLE OPERATION” (Exhibit A), duly and legally issued.

10. Velocity owns all rights, title, and interest in and to the ‘781 patent and has the right to sue and recover for past, present, and future infringement.

**COUNT I - INFRINGEMENT OF THE '781 PATENT**

11. Paragraphs 1 through 10 are incorporated by reference as though fully stated herein.

12. Audi manufactures, uses, imports, offers for sale, and sells automobiles that include radar equipment and radar-based safety features, including, for example, automobiles equipped with a Driver Assistance package.

13. Audi also manufactures, uses, imports, offers for sale, and sells automobiles with information displays that provide drivers with information regarding, for example, fuel consumption, efficiency of operation, and safety.

14. Additionally, Audi manufactures, uses, imports, offers for sale, and sells automobiles that include engines with cylinder on demand technology, which allows the engine to switch between a mode in which all of the engine cylinders are active, and a mode in which only a portion of the engine cylinders are active.

15. Furthermore, Audi manufactures, uses, imports, offers for sale, and sells automobiles that include manual gear shifting features, including, for example, automobiles equipped with automatic transmissions and a manual shift program.

16. By manufacturing, using, importing, offering for sale, and selling automobiles equipped with one or more of the features described above, Audi has directly infringed, and continues to infringe, either literally or under the doctrine of equivalents, at least claim 17 of the '781 Patent in violation of 35 U.S.C. § 271.

17. Velocity has been damaged by Audi's infringement of the '781 Patent.

**PRAYER FOR RELIEF**

**WHEREFORE**, Plaintiff Velocity prays that this Court:

- A. Enter a judgment that Audi has infringed the '781 Patent;
- B. Award Velocity damages in an amount sufficient to compensate Velocity for Audi's infringement of the '781 Patent, but not less than a reasonable royalty;
- C. Award Velocity prejudgment interest pursuant to 35 U.S.C. § 284; and
- D. Grant Velocity such other and further relief as this Court may deem just and proper.

**JURY DEMAND**

Velocity hereby demands a jury trial on all issues appropriately triable by a jury.

Dated: November 21, 2013

Respectfully submitted,

*/s/ James A. Shimota*

James A. Shimota

James A. Shimota (IL Bar No. 6270603)

Howard E. Levin (IL Bar No. 6286712)

Adam R. Brausa (IL Bar No. 6292447)

Aaron C. Taggart (IL Bar No. 6302068)

BRIDGES & MAVRAKAKIS LLP

180 North LaSalle Street, Suite 2215

Chicago, Illinois 60601

Telephone: 312-216-1626

Facsimile: 312-216-1621

jshimota@bridgesmav.com

hlevin@bridgesmav.com

abrausa@bridgesmav.com

ataggart@bridgesmav.com

*Counsel for Plaintiff Velocity Patent, LLC*

## EXHIBIT A

US005954781A

**United States Patent** [19]  
**Slepian et al.**

[11] **Patent Number:** 5,954,781  
 [45] **Date of Patent:** Sep. 21, 1999

- [54] **METHOD AND APPARATUS FOR OPTIMIZING VEHICLE OPERATION**
- [75] Inventors: **Harvey Slepian**, Peoria; **Loran Sutton**, East Peoria, both of Ill.
- [73] Assignee: **TAS Distributing Co., Inc.**, Peoria, Ill.
- [21] Appl. No.: **08/813,270**
- [22] Filed: **Mar. 10, 1997**
- [51] **Int. Cl.<sup>6</sup>** ..... **G06F 7/00**
- [52] **U.S. Cl.** ..... **701/96; 701/103; 340/425.5; 340/438**
- [58] **Field of Search** ..... **701/1, 121, 123, 701/101, 102, 103, 104, 96, 300; 123/478, 480, 351, 481; 340/903, 425.5, 426, 436, 438**

*Primary Examiner*—William A. Cuchlinski, Jr.  
*Assistant Examiner*—Gertrude Arthur  
*Attorney, Agent, or Firm*—Haynes and Boone, LLP

[57] **ABSTRACT**

Apparatus for optimizing operation of an engine-driven vehicle. The apparatus includes a processor subsystem, a memory subsystem, a road speed sensor, an engine speed sensor, a manifold pressure sensor, a throttle position sensor, a radar detector for determining the distance separating the vehicle from an object in front of it, a windshield wiper sensor for indicating whether a windshield wiper of the vehicle is activated, a brake sensor for determining whether the brakes of the vehicle have been activated, a fuel over-injection notification circuit for issuing notifications that excessive fuel is being supplied to the engine of the vehicle, an upshift notification circuit for issuing notifications that the engine of the vehicle is being operated at an excessive engine speed, a downshift notification circuit for issuing notifications that the engine of the vehicle is being operated at an insufficient engine speed, a vehicle proximity alarm circuit for issuing an alarm that the vehicle is too close to an object in front of the vehicle and a throttle controller for automatically reducing the amount of fuel supplied to the engine if the vehicle is too close to the object in front of it. Based upon data received from the sensors and data stored in the memory subsystem, the processor determines whether to activate the fuel overinjection notification circuit, the upshift notification circuit, the downshift notification circuit, the vehicle proximity alarm circuit or the throttle controller.

[56] **References Cited**  
**U.S. PATENT DOCUMENTS**

4,492,112	1/1985	Igarashi et al.	73/117.3
4,542,460	9/1985	Weber	364/424
4,631,515	12/1986	Blee et al.	340/62
4,701,852	10/1987	Ulvland	364/424.1
4,752,883	6/1988	Asakura et al.	364/424.1
4,853,673	8/1989	Kido et al.	340/439
4,868,756	9/1989	Kawanabe et al.	364/442
4,901,701	2/1990	Chasteen	123/478
5,420,792	5/1995	Butsuen et al.	701/96
5,708,584	1/1998	Doi et al.	701/96
5,745,870	4/1998	Yamamoto et al.	701/96

**32 Claims, 3 Drawing Sheets**

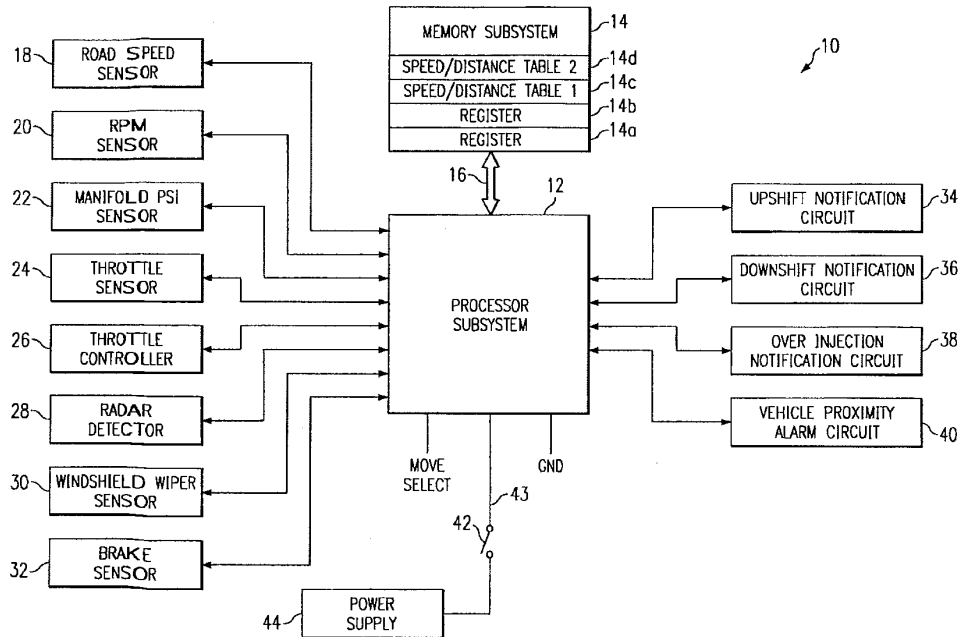

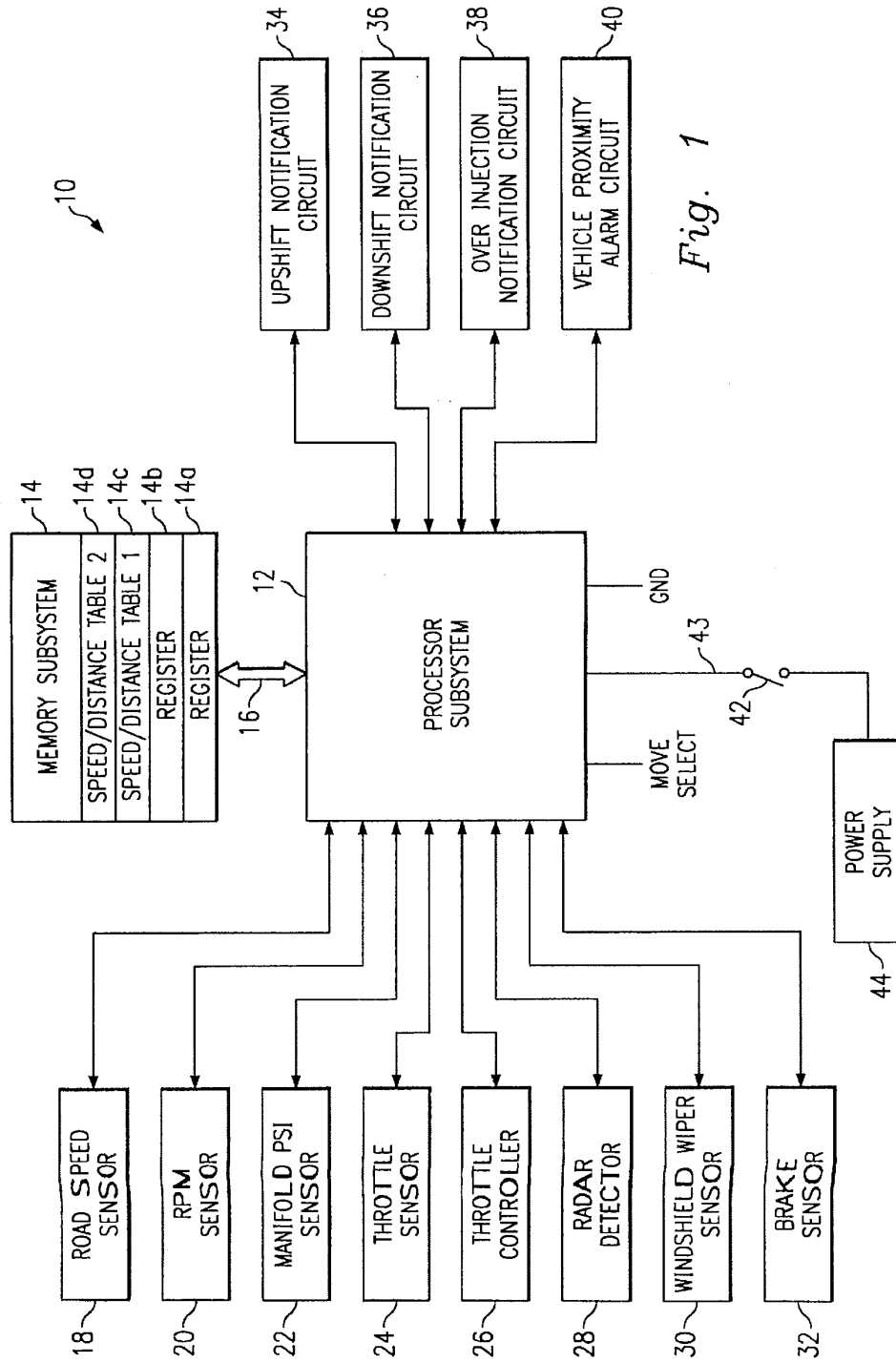
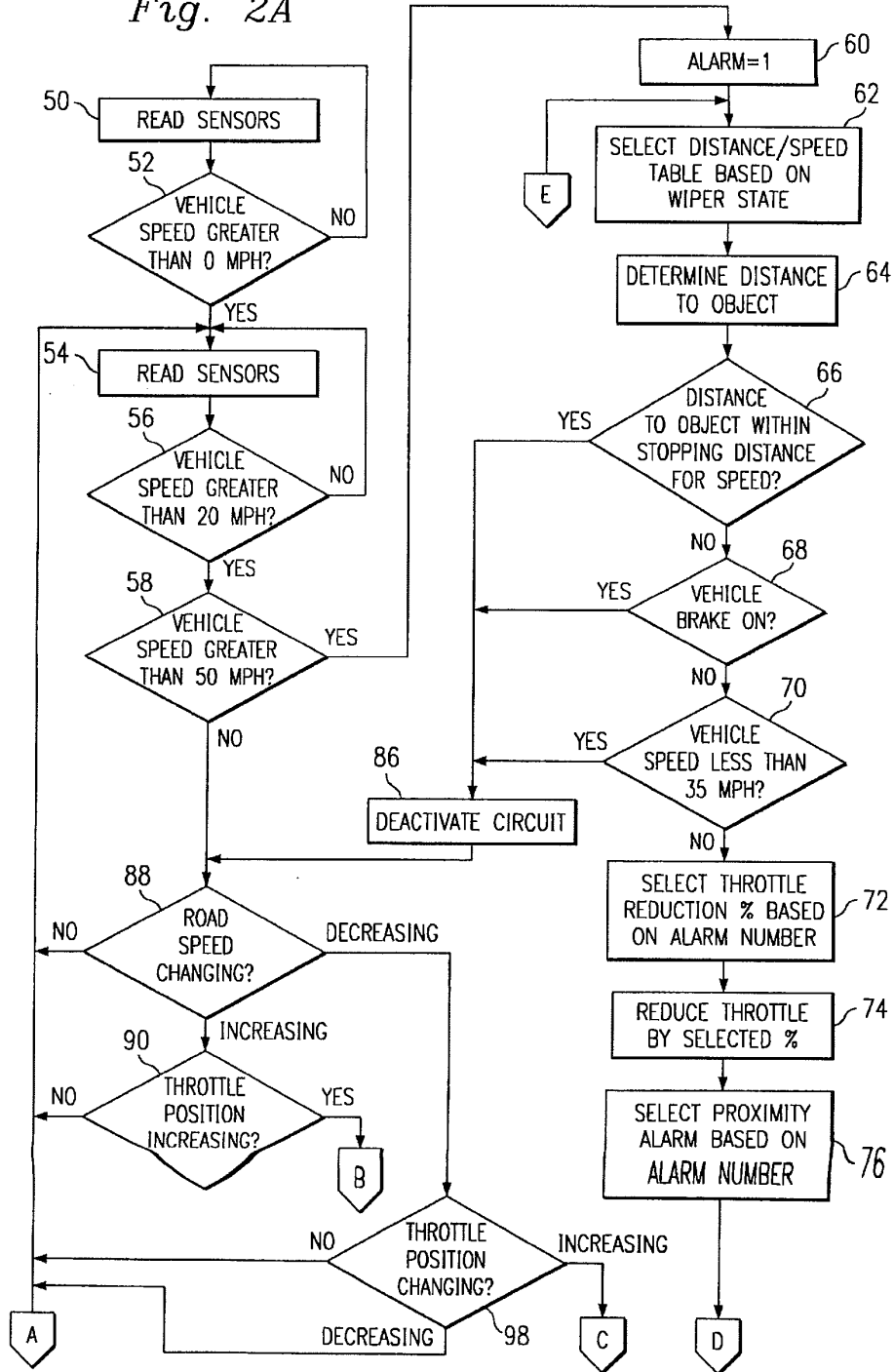
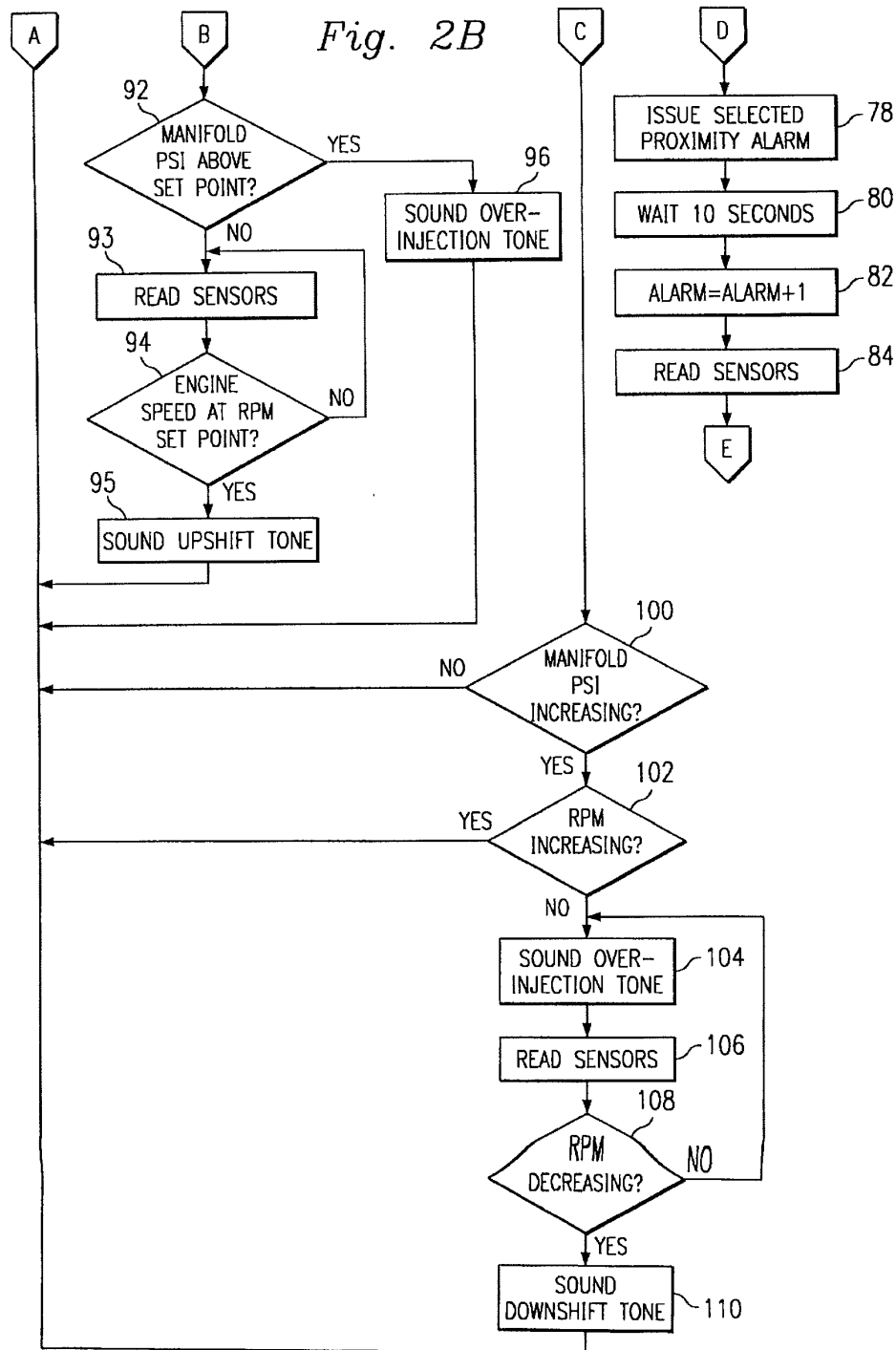

Fig. 1



Fig. 2A





5,954,781

1

**METHOD AND APPARATUS FOR  
OPTIMIZING VEHICLE OPERATION**

**BACKGROUND OF THE INVENTION**

1. Field of the Invention

The present invention generally relates to an apparatus for optimizing vehicle operation and, more particularly, relates to a system which both notifies the driver of recommended corrections in vehicle operation and, under certain conditions, automatically initiates selected corrective action.

2. Description of Related Art

It has long been recognized that the improper operation of a vehicle may have many adverse effects. For example, the fuel efficiency of a vehicle may vary dramatically based upon how the vehicle is operated. More specifically, operating a vehicle at excessive speed, excessive RPM and/or excessive manifold pressure will result in both reduced fuel economy and increased operating costs. The aforementioned increased operating costs can be quite considerable, particularly for an owner or operator of a fleet of vehicles. To correct these types of improper vehicle operations are often surprisingly simple. For example, upshifting the drive gear will typically eliminate an excessive RPM condition. However, even when the solution is quite simple, oftentimes, the driver will be unaware of the need to take corrective action.

A variety of patents have disclosed systems, commonly referred to as "shift prompters", which monitor the operation of a vehicle and advises the operator of the vehicle when to take certain actions. Numerous ones of these devices include sensors which measure engine speed and vehicle speed. See, for example, U.S. Pat. No. 4,492,112 to Igarashi et al., U.S. Pat. No. 4,631,515 to Blee et al. and U.S. Pat. No. 4,701,852 to Ulveland. Certain ones, however, disclose the use of other types of sensors as well. For example, U.S. Pat. No. 4,524,460 to Weber is directed to a driving aid indicator which includes vehicle speed, manifold pressure, throttle position and engine speed sensors. U.S. Pat. No. 4,752,883 to Asakura et al. and U.S. Pat. No. 4,868,756 to Kawanabe et al. are directed to upshift notification devices which include sensors for measuring engine speed, vehicle speed, manifold pressure and cooling water temperature. Finally, U.S. Pat. No. 4,853,673 to Kido et al. discloses a shift indicator system which includes sensors for measuring engine speed and throttle position. Generally, the above-listed patents all provide displays intended to enable the driver to operate the vehicle in a manner leading to uniform performance and maximum fuel economy. However, Blee et al. discloses the use of audible warnings as well as a speed controller to prevent further increases in engine speed if the driver ignores previously issued warnings.

Improper vehicle operation has other adverse effects as well. It is well known that the faster a vehicle travels, the longer it takes to stop. Thus, what may be a safe separation distance between successive vehicles when a vehicle is traveling at 35 mph may be unsafe if that vehicle is traveling at 50 mph. Road conditions also play a role in determining the safe separation distance between vehicles. For example, greater separation distances are generally recommended when roads are wet. As a result, therefore, based on the combination of a vehicle's speed, the distance separating the vehicle from a second vehicle in front of it and road conditions, many vehicles are operated unsafely. To correct this situation, a reduction in operating speed, an increase in vehicle separation or some combination thereof, is required.

It may be readily seen from the foregoing that it would be desirable to provide a system which integrates the ability to

2

issue audible warnings which advise the driver to correct operation of the vehicle in a manner which will enhance the efficient operation thereof with the ability to automatically take corrective action if the vehicle is being operated unsafely. It is, therefore, the object of the invention to provide such a system.

**SUMMARY OF THE INVENTION**

In one embodiment, the present invention is directed to an apparatus for optimizing operation of an engine-driven vehicle. The apparatus includes a processor subsystem, a memory subsystem, plural sensors, including road speed, manifold pressure and throttle position sensors, for collectively monitoring operation of the vehicle and a fuel overinjection notification circuit for issuing notifications that excessive fuel is being supplied to the engine of the vehicle. The processor subsystem receives data from the sensors and, from the received data, determines when to activate the fuel overinjection circuit. In one aspect thereof, the processor subsystem determines when road speed for the vehicle is increasing, determines when throttle position for the vehicle is increasing, compares manifold pressure and a manifold pressure set point stored in the memory subsystem and activates the fuel overinjection notification circuit if both road speed and throttle position for the vehicle are increasing and manifold pressure for the vehicle is above the manifold pressure set point.

In further aspects thereof, the sensors may include an engine speed sensor and the processor subsystem may determine when road speed for the vehicle is decreasing, when throttle position for the vehicle is increasing, when manifold pressure for the vehicle is increasing, when engine speed for the vehicle is decreasing and may activate the fuel overinjection notification circuit if both throttle position and manifold pressure for the vehicle are increasing and road speed and engine speed for the vehicle are decreasing.

In still further aspects thereof, the apparatus may also include an upshift notification circuit, activated by the processor subsystem based upon data received from the sensors, which issues notifications that the engine of the vehicle is being operated at excessive engine speeds. In this aspect, the processor subsystem determines when road speed for the vehicle is increasing, when throttle position for the vehicle is increasing, compares manifold pressure to a manifold pressure set point stored in the memory subsystem, compares engine speed to an RPM set point stored in the memory subsystem and activates the upshift notification circuit if both road speed and throttle position for the vehicle are increasing, manifold pressure for the vehicle is at or below the manifold pressure set point and engine speed for the vehicle is at or above the RPM set point.

In still yet further aspects thereof, the apparatus may also include a downshift notification circuit, activated by the processor subsystem based upon data received from the sensors, which issues a notification that the engine of the vehicle is being operated at an insufficient engine speed. The processor subsystem may determine when road speed for the vehicle is decreasing, when throttle position for the vehicle is increasing, when manifold pressure for the vehicle is increasing, when engine speed for the vehicle is decreasing and may activate the downshift notification circuit if both road speed and engine speed are decreasing and both throttle position and manifold pressure for the vehicle are increasing.

In still further aspects thereof, the fuel overinjection circuit, the upshift notification circuit or the downshift

5,954,781

3

notification circuit may include a horn for issuing a tone for a preselected time period.

In another embodiment, the present invention is of an apparatus for optimizing operation of a vehicle. The apparatus includes road speed, engine speed, manifold pressure and throttle position sensors, a processor subsystem coupled to each of the sensors to receive data therefrom and a memory subsystem, coupled to the processor subsystem, for storing a manifold pressure set point, an engine speed set point and present and prior levels for each one of the sensors. The apparatus further includes a fuel overinjection notification circuit, an upshift notification circuit and a downshift notification circuit, all of which are coupled to the processor subsystem. The fuel overinjection notification circuit issues notifications that excessive fuel is being supplied to the engine of the vehicle, the upshift notification circuit issues notifications that the engine of the vehicle is being operated at an excessive engine speed and the downshift notification circuit issues notifications that the engine of the vehicle is being operated at an insufficient engine speed. Based upon data received from the sensors, the processor subsystem determines when to activate the fuel overinjection circuit, the upshift notification circuit and the downshift notification circuit. In one aspect thereof, the fuel overinjection circuit includes a first horn for issuing a first tone for a first preselected time period, the upshift notification circuit includes a second horn for issuing a second tone for a second preselected time period and the downshift notification circuit includes a third horn for issuing a third tone for a third preselected time period.

In another aspect thereof, the processor subsystem may determine when road speed for the vehicle is increasing or decreasing, engine speed is increasing or decreasing, throttle position for the vehicle is increasing and manifold pressure is increasing; may compare manifold pressure to the manifold pressure set point and engine speed to the RPM set point; and may activate the fuel overinjection notification circuit if both road speed and throttle position for the vehicle are increasing and manifold pressure for the vehicle is above the manifold pressure set point or if both throttle position and manifold pressure for the vehicle are increasing and road speed and engine speed for the vehicle are decreasing, the upshift notification circuit if both road speed and throttle position for the vehicle are increasing, manifold pressure for the vehicle is at or below the manifold pressure set point and engine speed for the vehicle is at or above the RPM set point and the downshift notification circuit if both road speed and engine speed are decreasing and both throttle position and manifold pressure for the vehicle are increasing.

In another aspect, the present invention is of an apparatus for optimizing operation of a vehicle which includes a radar detector for determining a distance separating a vehicle having an engine and an object in front of the vehicle and at least one sensor for monitoring operation of the vehicle. The apparatus further includes a processor subsystem, a memory subsystem and a vehicle proximity alarm circuit. The processor subsystem is coupled to the radar detector and the at least one sensor to receive data therefrom while the memory subsystem, in which a first vehicle speed/stopping distance table and present levels for each one of the at least one sensor are stored, and the vehicle proximity alarm circuit are coupled to the processor subsystem. Based on data received from the radar detector, the at least one sensor and the contents of the memory subsystem, the processor determines when to instruct the vehicle proximity alarm circuit to issue an alarm that the vehicle is too close to the object.

In one aspect thereof, the at least one sensor further includes a windshield wiper sensor for indicating whether a

4

windshield wiper of the vehicle is activated and a second vehicle speed/stopping distance table is stored in the memory subsystem. In another aspect thereof, the apparatus further includes a throttle controller for controlling a throttle of the engine of the vehicle. The processor subsystem may selectively reduce the throttle based upon data received from the radar detector, the at least one sensor and the memory subsystem or may also count a total number of vehicle proximity alarms determined by the processor subsystem and selectively reduce the throttle based upon the total number of vehicle proximity alarms, as well. In yet another aspect thereof, the at least one sensor further includes a brake sensor for indicating whether a brake system of the vehicle is activated.

In other aspects thereof, the apparatus may be further provided with a fuel overinjection notification circuit for issuing a notification that excessive fuel is being supplied to the engine of the vehicle, an upshift notification circuit for issuing a notification that the engine of the vehicle is being operated at an excessive engine speed or a downshift notification circuit for issuing a notification that the engine of the vehicle is being operated at an insufficient engine speed. If a fuel overinjection notification circuit is provided, the apparatus includes a manifold pressure sensor and a throttle position sensor which also provide the processor subsystem with data used, together with a manifold pressure set point and prior levels for the sensors stored in the memory subsystem, to determine when to activate the fuel overinjection circuit. If an upshift notification circuit is provided, the apparatus includes an engine speed sensor which also provides the processor subsystem with data used, together with an RPM set point stored in the memory subsystem, to determine when to activate the upshift notification circuit. Finally, if a downshift notification circuit is provided, the processor subsystem determines when to activate the downshift notification circuit based upon the data received from the plurality of sensors.

In still another embodiment, the present invention is of an apparatus for optimizing operation of a vehicle which includes a radar detector for determining a distance separating the vehicle from an object in front of it, a plurality of sensors, including a road speed sensor, an engine speed sensor, a manifold pressure sensor and a throttle position sensor, which collectively monitor the operation of the vehicle, a processor subsystem, a memory subsystem, a fuel overinjection notification circuit for issuing notification that excessive fuel is being supplied to the engine of the vehicle and a vehicle proximity alarm circuit for issuing alarms if the vehicle is too close to the object. Based upon data received from the sensors, the processor subsystem determines when to activate the fuel overinjection circuit. Based upon data received from the radar detector, the sensors and the memory subsystem, the processor subsystem also determines when to activate the vehicle proximity alarm circuit.

In one aspect of this embodiment of the invention, the processor subsystem determines when road speed for the vehicle is increasing or decreasing, when throttle position for the vehicle is increasing or decreasing, compares manifold pressure to a manifold pressure set point stored in the memory subsystem, determines when manifold pressure for the vehicle is increasing or decreasing and determines when engine speed for the vehicle is increasing or decreasing. In this aspect, the processor subsystem activates the fuel overinjection notification circuit if both road speed and throttle position for the vehicle are increasing and manifold pressure for the vehicle is above the manifold pressure set point or if both throttle position and manifold pressure for the vehicle

5,954,781

5

are increasing and road speed and engine speed for the vehicle are decreasing.

In a further aspect thereof, the apparatus may also include an upshift notification circuit for issuing notifications that the engine of the vehicle is being operated at an excessive engine speed, the processor subsystem determining when to activate the upshift notification circuit based upon data received from the sensors. In a related aspect thereof, the processor subsystem determines when road speed for the vehicle is increasing, determines when throttle position for the vehicle is increasing, compares manifold pressure to a manifold pressure set point stored in the memory subsystem and compares engine speed to an RPM set point stored in the memory subsystem. In this aspect, the processor subsystem activates the upshift notification circuit if both road speed and throttle position for the vehicle are increasing, manifold pressure for the vehicle is at or below the manifold pressure set point and engine speed for the vehicle is at or above the RPM set point.

In still another aspect thereof, the apparatus may also include a downshift notification circuit for issuing a notification that the engine of the vehicle is being operated at an insufficient engine speed. In this aspect, the processor subsystem determines when to activate the downshift notification circuit based upon data received from the sensors. In a related aspect thereof, the processor subsystem determines when road speed for the vehicle is decreasing, determines when throttle position for the vehicle is increasing, determines when manifold pressure for the vehicle is increasing and determines when engine speed for the vehicle is decreasing. In this aspect, the processor subsystem activates the downshift notification circuit if both road speed and engine speed are decreasing and both throttle position and manifold pressure for the vehicle are increasing.

#### BRIEF DESCRIPTION OF THE DRAWINGS

The present invention may be better understood, and its numerous objects, features and advantages will become apparent to those skilled in the art by reference to the accompanying drawing, in which:

FIG. 1 is a block diagram of an apparatus for optimizing vehicle performance constructed in accordance with the teachings of the present invention; and

FIGS. 2A–B is a flow chart of a method for optimizing vehicle performance in accordance with the teachings of the present invention.

#### DETAILED DESCRIPTION

Referring first to FIG. 1, a system 10 for optimizing vehicle performance constructed in accordance with the teachings of the present invention will now be described in greater detail. The system 10 includes a processor subsystem 12, for example, a microprocessor, and a memory subsystem 14, for example, the memory subsystem 14 may include a nonvolatile random access memory (or “NVRAM”), coupled together by a bus 16 for bi-directional exchanges of address, data and control signals therebetween. The system 10 is installed in a vehicle (not shown) for which optimized performance and driver assist capabilities are desired. Although it is contemplated that the system 10 is suitable for use with any type vehicle, most commonly, the system 10 shall be installed in a truck.

Also coupled to the processor subsystem 12 are a series of sensors, each of which are periodically polled by the processor subsystem 12, to determine the respective states or

6

levels thereof. The sensors include a road speed sensor 18, an RPM sensor 20, a manifold pressure sensor 22, a throttle sensor 24, a windshield wiper sensor 30 and a brake sensor 32. The sensors are selected to be either state or level sensors, depending on whether the information to be collected thereby is a state, i.e., on/off or a level, for example, 35 mph. The road speed sensor 18 and the RPM sensor 20 are level sensors which respectively provide the processor subsystem 12 with signals which indicate the operating speed and engine speed for the vehicle. The road speed sensor 18 and the RPM sensor 20 may derive such information from any one of a variety of sources. For example, the road speed sensor 18 may be connected to receive the speed input signal transmitted to the vehicle’s speedometer while the RPM sensor 20 may be connected to receive the RPM input signal to the vehicle’s tachometer.

The manifold pressure sensor 22 is a level sensor which is positioned downstream of the throttle valve in the intake manifold of the vehicle to measure manifold pressure thereat. The throttle sensor 24 is a level sensor, attached to the throttle, which measures the extent to which the throttle is opened. The windshield wiper sensor 30 is a state sensor which determines whether the vehicle’s windshield wipers are on or off. In alternate embodiments thereof, the windshield wiper sensor 30 may be electrically coupled to the on/off switch for the windshield wiper or to an output of the windshield wiper motor. Finally, the brake sensor 32 is a state sensor which determines whether the brakes of the vehicle have been engaged. For example, the brake sensor 32 may be electrically coupled to the brake system to detect the activation thereof.

Preferably, the memory subsystem 14 should include first and second registers 14a and 14b, each having sufficient bits for holding the state/level of each of the sensors 18, 20, 22, 24, 30 and 32. The first register 14a is used to hold the present state or level of each of the sensors 18, 20, 22, 24, 30 and 32 while the second register 14b is used to hold the prior state or level for each of the sensors 18, 20, 22, 24, 30 and 32. Each time the processor subsystem 12 writes the present state or level of the sensors 18, 20, 22, 24, 30 and 32 to the first register 14a, the prior contents of the first register 14a is written to the second register 14b which, in turn, discards the prior content thereof. The memory subsystem 14 is also used to hold information to be utilized by the processor subsystem 12 to determining whether to take corrective actions and/or issue notifications. Typically, such information is placed in the memory subsystem 14 while the system 10 is being initialized. The information includes one or more speed/distance tables which, when used in a manner which will be more fully described below in combination with data collected by the system 10, enable the processor subsystem 12 to determine if the vehicle is being operated unsafely and if corrective action is necessary. Speed/stopping distance table. The information also includes two pre-set threshold values—a manifold psi set point and an engine RPM set point. As will also be more fully described below, the processor subsystem 12 uses these threshold values to determine when to issue notifications as to recommended changes in vehicle operation which, when executed by the driver, will optimize vehicle operation. The speed/stopping distance table(s) are based upon National Safety Council guidelines, vary according to the class of the vehicle and provide the relationship between the speed at which a vehicle is travelling and the distance which the vehicle will require to come to a complete stop if travelling at that speed. The manifold psi set point and RPM set point are selected based upon the manufacturer’s guidelines for

5,954,781

7

proper operation of the vehicle, vary based upon horsepower and engine size for the vehicle and represent thresholds above which the manifold pressure and engine rotation speed, respectively, for the vehicle should never exceed.

The system 10 also includes a throttle controller 26 capable of opening and/or closing the throttle, a radar detector 28 positioned to determine the distance separating the vehicle and an object in front of the vehicle, for example, a second vehicle travelling in the same direction, a series of circuits 34, 36, 38 and 40 for notifying the driver of the vehicle of recommended corrections in vehicle operation and alerting the driver to unsafe operating conditions and a power supply, for example a +12 v battery, for providing power to the energy-demanding components of the system 10. The circuits 34, 36, 38 and 40 include an upshift notification circuit 34 for notifying the driver that an upshift is recommended, a downshift notification circuit 36 for notifying the driver that a downshift is recommended, an overinjection notification circuit 38 for notifying the driver that too much fuel is being supplied to the vehicle and a vehicle proximity alarm circuit 40 for alerting the driver when an object in front of the vehicle is too close. The circuits 34, 36 and 38 may be configured to provide visual and/or audible notifications, for example, using lights and/or horns. For example, the upshift circuit 34, the downshift notification circuit 36 and the overinjection notification circuit 38 may each include a horn, or other tone generating device, from which an audible notification may be generated at a selected pitch. Preferably, each of the notification circuits 34, 36 and 38 may be configured to provide distinct audible notifications, for example, tones at distinct pitches, so that the driver may readily distinguish which of the notification circuits 34, 36 and 38 have been activated by the processor subsystem 12. The proximity alarm circuit 40 may include one or more visual and/or audible warning devices such as lights and/or horns. For example, the proximity alarm circuit 40 may include a warning light and a warning horn. If desired, the proximity alarm circuit may also include a display for displaying the speed of the object in the vehicle's path and/or the stopping distance in feet. The proximity alarm circuit 40 may be further equipped to provide audible indications of the speed of the object in the vehicle's path and/or the stopping distance in feet as well as selector circuitry for selecting both the information to be provided as well as the manner in which the information is to be conveyed.

Finally, the processor subsystem 12 is further provided with one or more mode select input lines which enable operator configuration of the operation of the system 10. For example, as described herein, the corrective operations consist of the combination of an automatic reduction of throttle and audio/visual alerts that the vehicle is being operated unsafely. It is specifically contemplated, however, that the system 10 include a mode select line for switching the system 10 between an "active" mode where both automatic throttle reduction and audio/visual alerts are generated and an "inactive" mode where only audio/visual alerts are generated.

Referring next to FIGS. 2A-B, a method for optimizing vehicle performance in accordance with the teachings of the present invention will now be described in greater detail. The method commences by powering up the processor subsystem 12, for example, by closing switch 42, thereby coupling the processor subsystem 12 to the power source 44 via line 43. Alternately, the processor subsystem 12 may be connected to the electrical system of the vehicle such that it will automatically power up when the vehicle is started. Of

8

course, any of the other devices which also form part of the system 10 and require power may also be coupled to the line 43. Appropriate voltage levels for the processor subsystem 12, as well as any additional power-demanding devices coupled to the power source 44, would be provided by voltage divider circuitry (not shown).

Once the system 10 is powered up, the method begins at step 50 by the processor subsystem 12 polling the road speed sensor 18, the RPM sensor 20, the manifold pressure sensor 22, the throttle sensor 24, the windshield wiper sensor 30 and the brake sensor 32 to determine their respective levels or states and places the acquired information in the first data register 14a. Of course, it should be noted, however, that polling of the sensors by the processor subsystem 12 is but one technique by which the processor subsystem 12 may acquire the requisite information. Alternately, each sensor 20, 22, 24, 30 and 32 may periodically place its level or state in one or more bits of the first data register 14a. The processor subsystem 12 would then acquire information by checking the contents of the first data register 14a at selected time intervals.

Proceeding to step 52, the processor subsystem 12 examines the contents of the first data register 14a to determine the operating speed of the vehicle. If the processor subsystem 12 determines that the vehicle is stationary, i.e., the operating speed of the vehicle is zero, the processor subsystem 12 will return to step 50 where the road speed sensor 18, the RPM sensor 20, the manifold pressure sensor 22, the throttle sensor 24, the windshield wiper sensor 30 and the brake sensor 32 will be repeatedly polled until an operating speed greater than zero is detected at step 52. While polling may be conducted at a variety of time intervals, a polling period of one second appears suitable for the uses contemplated herein.

Returning to step 52, once an operating speed greater than zero is detected by the processor subsystem 12, the method proceeds to step 54 where the processor subsystem 12 again polls the operating speed sensor 18, the RPM sensor 20, the manifold pressure sensor 22, the throttle sensor 24, the windshield wiper sensor 30 and the brake sensor 32, to determine their respective levels or states and places the acquired information in the first data register 14a. In turn, the contents of the first data register 14a is placed in the second data register 14b.

Proceeding now to step 56, from the polled value of the road speed sensor 18, the processor subsystem 12 determines whether the vehicle is travelling faster than 20 mph. If the operating speed of the vehicle is less than 20 mph, the method returns to step 54 where the sensors 18, 20, 22, 24, 30 and 32 will be repeatedly polled and the value of the road speed sensor examined until the processor subsystem 12 determines that the vehicle is travelling faster than 20 mph. If, however, the processor subsystem 12 determines that the vehicle is travelling faster than 20 mph, the method proceeds to step 58 where the processor subsystem 12 then determines if the vehicle is travelling faster than 50 mph, again by checking the contents of the first data register 14a.

Past this juncture, the method of the present invention will proceed through a series of steps designed to optimize vehicle operation. However, prior to optimizing vehicle operation, the processor subsystem 12 will determine if the vehicle is being operated unsafely. If so, the processor subsystem 12 will initiate corrective operations before commencing vehicle operation optimization. More specifically, if the processor subsystem 12 determines at step 58 that the vehicle is travelling at a speed greater than 50 mph, the

5,954,781

9

processor subsystem 12 will initiate a process by which it will determine whether the vehicle is being operated unsafely.

The processor subsystem 12 determines that the vehicle is being operated unsafely if the speed of the vehicle is such that the stopping distance for the vehicle *d* is greater than the distance separating the vehicle from an object, for example, a second vehicle, in its path. In order to make this determination, the processor subsystem 12 is provided access to at least one speed/distance table. For example, stored at location 14c within the memory subsystem 14 is a first speed/stopping distance table. The speed/stopping distance table contains the relationship between vehicle speed and stopping distance. Thus, for any given speed, the processor subsystem 12 may look-up the stopping distance for that speed. Preferably, the memory subsystem 14 should contain multiple speed/stopping distance tables so that differences in road conditions and/or vehicle class may be taken into account. For example, the speed/stopping distance table stored at location 14c may be a speed/stopping distance table for dry roads while a speed/stopping distance table for wet roads may be stored at location 14d. If desired, the memory subsystem 14 may also contain additional speed/stopping distance tables for other vehicle classes. If such additional tables were provided, however, the disclosed method would need to be modified to include additional steps in which the operator provides the vehicle's class and the processor subsystem 12 selects the appropriate speed/stopping distance tables for the indicated class of vehicle.

To make the aforementioned determination of unsafe vehicle operation, the method proceeds to step 60 where the processor subsystem 12 sets the value of the expression ALARM to 1. The method then proceeds to step 62 where the processor subsystem 12 examines the state of the wiper sensor 32 and selects a speed/stopping distance table based upon the state of the wiper sensor 32. If the state of the wiper sensor 32 indicates that the windshield wiper is off, the processor subsystem 12 concludes that the vehicle is being operated in dry conditions and selects the speed/stopping distance table stored at the location 14c of the memory subsystem 14. If, however, the state of the wiper sensor 32 indicates that the windshield wiper is on, the processor subsystem 12 concludes that the vehicle is being operated in wet conditions and selects the speed/stopping distance table stored at the location 14d of the memory subsystem 14. From the selected speed/stopping distance table 14c or 14d, the processor subsystem 12 then retrieves the stopping distance for the speed at which the vehicle is travelling.

Continuing on to step 64, the processor subsystem 12 determines the distance of the vehicle to an object in its path, i.e., a second vehicle travelling in front of the vehicle and in the same direction. To do so, the processor subsystem 12 instructs the radar device 28 to determine the distance between the vehicle and the second vehicle in front of it. Upon determining the distance separating the two vehicles, the radar device 28 transmits the determined separation distance to the processor subsystem 12. At step 66, the processor subsystem 12 determines if the two vehicles are separated by a safe distance. To do so, the processor subsystem 12 compares the distance separating the two vehicles to the retrieved stopping distance for the vehicle. If the determined distance separating the two vehicles is greater than the retrieved stopping distance for the vehicle, the processor subsystem 12 determines that the vehicle is being operated safely. If, however, the determined distance separating the two vehicles is less than the retrieved stopping distance, the processor subsystem 12 determines that the vehicle is being operated unsafely.

10

If the processor subsystem 12 determines at step 66 that the vehicle is being operated unsafely, the processor subsystem 12 initiates appropriate corrective action. At step 68, the processor subsystem 12 determines whether the vehicle brake is on by examining the state of the brake sensor 32. If the brake is on, the processor subsystem 12 concludes that the driver is taking corrective action and that further corrective action is not necessary. If, however, the processor subsystem 12 determines that the vehicle brake is off, the method proceeds to step 70 where the processor subsystem 12 examines the level of the vehicle speed sensor to determine if the speed of the vehicle is less than 35 mph. If the speed of the vehicle is less than 30 mph, the processor subsystem 12 concludes that no further corrective action will be taken.

If, however, the processor subsystem 12 determines that the speed of the vehicle is greater than 35 mph, the method proceeds to step 72 where the processor subsystem 12 selects a throttle reduction value based upon the value of the expression ALARM. Generally, the severity of the corrective action to be initiated by the processor subsystem 12 is varied depending on the number of times that corrective action has been taken and, more specifically, the severity of the selective corrective action increases with the value of the expression ALARM. For example, in the embodiment of the invention disclosed herein, if ALARM=1, a 25% throttle reduction is selected, if ALARM=2, a 50 throttle reduction is selected and, if ALARM $\geq$ 3, a 100% throttle reduction is selected. By reducing the throttle, the transport of fuel to the engine is retarded and the vehicle will begin to decelerate.

Continuing on to step 74, the processor subsystem 12 determines the extent to which the throttle is open using the throttle level provided by the throttle sensor 24 and, using throttle control 26, reduces the throttle by the selected percentage. At step 76, the processor subsystem 12 selects an alert mode, again based upon the value of the expression ALARM. As before, the severity of the alert mode may increase with the value of ALARM. For example, when ALARM=1, a warning light may be activated in a flash mode while, when  $2 \leq \text{ALARM} \leq 3$ , an audible alert which lasts for a first selected time period, for example, two seconds, may be activated in combination with the flashing warning light and when ALARM $\geq$ 4, an audible alert which lasts for a second, longer, time period, for example, six seconds, may be activated in combination with the flashing light.

Proceeding to step 78, the processor subsystem 12 issues an alert to the operator of the vehicle in accordance with the selected alert mode. To do so, the processor subsystem 12 activates vehicle proximity alarm circuit 40 in accordance with the selected alert mode. After issuing the alert at step 78, the method proceeds to step 80 where the processor subsystem 12 waits a selected period before taking any further action. The wait period is intended to provide sufficient time to see if the previously initiated corrective action eliminates the hazardous condition. As disclosed herein, a wait period of 10 seconds is suitable. However, wait periods of various lengths should be equally suitable for the uses contemplated herein.

Upon expiration of the wait period, the value of the expression ALARM is incremented by one at step 82 and, at step 84, the processor subsystem 12 again polls the operating speed sensor 18, the RPM sensor 20, the manifold pressure sensor 22, the throttle sensor 24, the windshield wiper sensor 30 and the brake sensor 32, to determine their respective levels or states and places the acquired information in the first data register 14a. The method returns to step 64 where the distance between the vehicle and the object in its path is

5,954,781

11

re-determined. The processor subsystem 12 continues to take corrective action until it determines that the vehicle is no longer being operated in a hazardous manner. More specifically, the processor subsystem 12 will conclude that the hazardous condition has been corrected when it either: determines at step 66 that the distance separating the vehicle and the object is within the stopping distance for the vehicle, determines at step 68 that the vehicle brake is on or determines at step 70 that the speed of the vehicle is less than 35 mph. Upon making such a determination, the method proceeds to step 86 where the processor subsystem 12 deactivated the vehicle proximity alarm circuit 40 to turn off the flashing light.

The method of optimizing vehicle operation in accordance with the teachings of the present invention will now be described in greater detail. Returning now to step 58, if the processor subsystem 12 determines that the vehicle is travelling slower than 50 mph, or if the processor subsystem 12 determines at step 66 that the distance separating the vehicle and the object is within the stopping distance for the vehicle or if the processor subsystem 12 determines at step 68 that the vehicle brake is on or if the processor subsystem 12 determines at step 70 that the speed of the vehicle is less than 35 mph, the method proceeds, after deactivation of the vehicle proximity alarm circuit 40, to step 88 where the processor subsystem 12 determines if the road speed of the vehicle is changing. To do so, the processor subsystem 12 compares the speed of the vehicle maintained in the first register 14a to the speed of the vehicle maintained in the second register 14b.

If the vehicle speed maintained in the first register 14a is greater than the vehicle speed maintained in the second register 14b, the vehicle is accelerating. If so, the method continues to step 90 where the processor subsystem 12 determines if the throttle position is increasing. To do so, the processor subsystem 12 compares the throttle level, i.e., the extent to which the throttled is opened, maintained in the first register 14a to the throttle level maintained in the second register 14b. If the throttle position has not increased, the processor subsystem 12 determines that, since the vehicle is accelerating but fuel consumption is not increasing, no modification of vehicle operation is necessary. Accordingly, the method returns to step 54 for a next polling of the sensors 18, 20, 22 24, 30 and 32.

If, however, the processor subsystem 12 determines at step 90 that the throttle position has increased, the method proceeds to step 92 where the processor subsystem 12 determines if the manifold pressure level maintained in the first register 14a has exceeded the manifold pressure set point for the vehicle. If the vehicle's road speed and throttle position are increasing and the manifold pressure for the vehicle is at or below the manifold pressure set point, the processor subsystem 12 proceeds to step 93 where the sensors 18, 20, 22, 24, 30 and 32 are again polled and on to step 94 where the processor subsystem 12 compares the engine speed level maintained in the first register 14a to the RPM set point stored in the memory subsystem 14 to determine if the engine speed has reached the RPM set point. If the engine speed has not reached the RPM set point, the method returns to step 93 where the sensors 18, 20, 22, 24, 30 and 32 are repeatedly polled until the processor subsystem 12 determines that the engine speed has reached the RPM set point. Once the engine speed has reached the RPM set point, the processor subsystem 12 determines that the vehicle needs to be upshifted and, proceeding to step 95, the processor subsystem 12 will activate the upshift notification circuit 34 to issue an audible alert for a selected time period,

12

for example, 6 seconds, thereby notifying the driver that, in order to optimize vehicle operation, an upshift should be performed. The method then returns to step 54 for a next polling of the sensors 18, 20, 22 24, 30 and 32.

Returning to step 92, if the vehicle's road speed and throttle position are increasing and the manifold pressure for the vehicle is above the manifold pressure set point, the processor subsystem 12 determines that too much fuel is being provided to the engine and proceeding to step 96, the processor subsystem 12 will activate the overinjection notification circuit 38 to issue an audible alert for a selected time period, for example, 6 seconds, thereby notifying the driver that, in order to optimize vehicle operation, the amount of fuel being supplied to the engine should be reduced. The method then returns to step 54 for a next polling of the sensors 18, 20, 22 24, 30 and 32.

Returning to step 88, if the processor subsystem 12 determines, when comparing the speed of the vehicle maintained in the first register 14a to the speed of the vehicle maintained in the second register 14b, that the speed of the vehicle is decreasing, the method proceeds to step 98 where the processor subsystem 12 determines if the throttle position is changing. To do so, the processor subsystem 12 compares the throttle level, i.e., the extent to which the throttled is opened, maintained in the first register 14a to the throttle level maintained in the second register 14b. If the throttle position has either remained constant or decreased, the processor subsystem 12 determines that, since fuel consumption is either constant or reduced, no modification of vehicle operation is necessary. Accordingly, the method returns to step 54 for a next polling of the sensors 18, 20, 22 24, 30 and 32.

If, however, the processor subsystem 12 determines at step 98 that the throttle position has increased, the method proceeds to step 100 where the processor subsystem 12 determines if the manifold pressure is increasing. To do so, the processor subsystem 12 compares the manifold pressure level maintained in the first register 14a to the manifold pressure level maintained in the second register 14b. If the manifold pressure level maintained in the first register 14a is less than the manifold pressure level maintained in the second register 14b, the processor subsystem 12 determines that, since manifold pressure is decreasing, no modification of vehicle operation is necessary. Accordingly, the method returns to step 54 for a next polling of the sensors 18, 20, 22 24, 30 and 32.

If, however, the manifold pressure level maintained in the first register 14a is greater than the manifold pressure level maintained in the second register 14b, the processor subsystem 12 determines that the manifold pressure for the vehicle is increasing and the method proceeds to step 102 where the processor subsystem 12 determines if the engine speed is increasing. To do so, the processor subsystem 12 compares the engine speed level maintained in the first register 14a to the engine speed level maintained in the second register 14b. If the engine speed level maintained in the first register 14a is less than the engine speed level maintained in the second register 14b, the processor subsystem 12 determines that, since engine speed is increasing, no modification of vehicle operation is necessary. Accordingly, the method returns to step 54 for a next polling of the sensors 18, 20, 22 24, 30 and 32.

If, however, the engine speed level maintained in the first register 14a is less than the engine speed level maintained in the second register 14b, the processor subsystem 12 determines that, since the manifold pressure is increasing while



5,954,781

13

the engine speed is decreasing, too much fuel is being supplied to the engine. Accordingly, at step 104, the processor subsystem 12 activates the overinjection notification circuit 38 to issue an audible alert for a selected time period, for example, 6 seconds, thereby notifying the driver that, in order to optimize vehicle operation, the amount of fuel being supplied to the engine should be reduced.

Proceeding on to step 106, the sensors 18, 20, 22 24, 30 and 32 are again polled and, at step 108, the processor subsystem 12 determines if the engine speed is decreasing, again by comparing the engine speed level maintained in the first and second registers 14a and 14b. If the engine speed has not decreased, the method returns to step 104 where the processor subsystem 12 again activates the overinjection notification circuit 38 to issue another audible alert notifying the driver that, in order to optimize vehicle operation, the amount of fuel being supplied to the engine should be reduced. Thus, the driver will be repeatedly notified of the overinjection condition until the processor subsystem 12 determines, at step 108, that the engine speed is decreasing. The method will then proceed to step 110 where, since the processor subsystem 12 has determined that, since the engine speed is decreasing, the vehicle should be downshifted. Accordingly, at step 110, the processor subsystem 12 activates the downshift notification circuit 36 to issue an audible alert for a selected time period, for example, 6 seconds, thereby notifying the driver that, in order to optimize vehicle operation, the vehicle should be downshifted. The method then returns to step 54 for a next polling of the sensors 18, 20, 22 24, 30 and 32. The method will repeatedly loop through the aforementioned process to continuously determine if the vehicle is being operated unsafely, take appropriate corrective action and to provide notifications to the driver as to how operation of the vehicle may be optimized until the processor subsystem 12 is powered down or the vehicle is turned off.

Thus, there has been described and illustrated herein, an apparatus for optimizing vehicle operation which combines both operator notifications of recommended corrections in vehicle operation with automatic modification of vehicle operation under certain circumstances. By incorporating the disclosed apparatus in a vehicle, not only will certain hazardous operations of the vehicle be prevented but also the driver will be advised of certain actions which will enable the vehicle to be operated with greater fuel efficiency. However, those skilled in the art will recognize that many modifications and variations besides those specifically mentioned herein may be made without departing substantially from the concept of the present invention. Accordingly, it should be clearly understood that the form of the invention described herein is exemplary only and is not intended as a limitation on the scope of the invention.

What is claimed is:

1. Apparatus for optimizing operation of a vehicle, comprising:

- a plurality of sensors coupled to a vehicle having an engine, said plurality of sensors, which collectively monitor operation of said vehicle, including a road speed sensor, an engine speed sensor, a manifold pressure sensor and a throttle position sensor;
- a processor subsystem, coupled to each one of said plurality of sensors, to receive data therefrom;
- a memory subsystem, coupled to said processor subsystem, said memory subsystem storing therein a manifold pressure set point, an RPM set point, and present and prior levels for each one of said plurality of sensors;

14

a fuel overinjection notification circuit coupled to said processor subsystem, said fuel overinjection notification circuit issuing a notification that excessive fuel is being supplied to said engine of said vehicle;

an upshift notification circuit coupled to said processor subsystem, said upshift notification circuit issuing a notification that said engine of said vehicle is being operated at an excessive speed;

said processor subsystem determining, based upon data received from said plurality of sensors, when to activate said fuel overinjection circuit and when to activate said upshift notification circuit.

2. Apparatus for optimizing operation of a vehicle according to claim 1 wherein said processor subsystem further comprises:

means for determining when road speed for said vehicle is increasing;

means for determining when throttle position for said vehicle is increasing; and

means for comparing manifold pressure to said manifold pressure set point;

said processor subsystem activating said fuel overinjection notification circuit if both road speed and throttle position for said vehicle are increasing and manifold pressure for said vehicle is above said manifold pressure set point.

3. Apparatus for optimizing operation of a vehicle according to claim 1 wherein said fuel overinjection circuit further comprises a horn for issuing a tone for a preselected time period.

4. Apparatus for optimizing operation of a vehicle according to claim 1 wherein said processor subsystem further comprises:

means for determining when road speed for said vehicle is decreasing;

means for determining when throttle position for said vehicle is increasing;

means for determining when manifold pressure for said vehicle is increasing; and

means for determining when engine speed for said vehicle is decreasing;

said processor subsystem activating said fuel overinjection notification circuit if both throttle position and manifold pressure for said vehicle are increasing and road speed and engine speed for said vehicle are decreasing.

5. Apparatus for optimizing operation of a vehicle according to claim 1 wherein said processor subsystem further comprises:

means for determining when road speed for said vehicle is increasing;

means for determining when throttle position for said vehicle is increasing;

means for comparing manifold pressure to said manifold pressure set point; and

means for comparing engine speed to said RPM set point; said processor subsystem activating said upshift notification circuit if both road speed and throttle position for said vehicle are increasing, manifold pressure for said vehicle is at or below said manifold pressure set point and engine speed for said vehicle is at or above said RPM set point.

6. Apparatus for optimizing operation of a vehicle according to claim 1 wherein said upshift notification circuit further comprises a horn for issuing a tone for a preselected time period.

5,954,781

15

7. Apparatus for optimizing operation of a vehicle, comprising:

a plurality of sensors coupled to a vehicle having an engine, said plurality of sensors, which collectively monitor operation of said vehicle, including a road speed sensor, a manifold pressure sensor and a throttle position sensor;

a processor subsystem, coupled to each one of said plurality of sensors, to receive data therefrom;

a memory subsystem, coupled to said processor subsystem, said memory subsystem storing therein a manifold pressure set point and present and prior levels for each one of said plurality of sensors;

a fuel overinjection notification circuit coupled to said processor subsystem, said fuel overinjection notification circuit issuing a notification that excessive fuel is being supplied to said engine of said vehicle;

a downshift notification circuit coupled to said processor subsystem, said downshift notification circuit issuing a notification that said engine of said vehicle is being operated at an insufficient engine speed; and

said processor subsystem determining, based upon data received from said plurality of sensors, when to activate said fuel overinjection circuit and when to activate said downshift notification circuit.

8. Apparatus for optimizing operation of a vehicle according to claim 7 wherein said processor subsystem further comprises:

means for determining when road speed for said vehicle is increasing;

means for determining when throttle position for said vehicle is increasing; and

means for comparing manifold pressure to said manifold pressure set point;

said processor subsystem activating said fuel overinjection notification circuit if both road speed and throttle position for said vehicle are increasing and manifold pressure for said vehicle is above said manifold pressure set point.

9. Apparatus for optimizing operation of a vehicle according to claim 7 wherein said fuel overinjection circuit further comprises a horn for issuing a tone for a preselected time period.

10. Apparatus for optimizing operation of a vehicle according to claim 7 wherein said processor subsystem further comprises:

means for determining when road speed for said vehicle is decreasing;

means for determining when throttle position for said vehicle is increasing;

means for determining when manifold pressure for said vehicle is increasing; and

means for determining when engine speed for said vehicle is decreasing;

said processor subsystem activating said downshift notification circuit if both road speed and engine speed are decreasing and both throttle position and manifold pressure for said vehicle are increasing.

11. Apparatus for optimizing operation of a vehicle according to claim 10 wherein said downshift notification circuit further comprises a horn for issuing a tone for a preselected time period.

12. Apparatus for optimizing operation of a vehicle according to claim 7 wherein said processor subsystem further comprises:

16

means for determining when road speed for said vehicle is decreasing;

means for determining when throttle position for said vehicle is increasing;

means for determining when manifold pressure for said vehicle is increasing; and

means for determining when engine speed for said vehicle is decreasing;

said processor subsystem activating said fuel overinjection notification circuit if both throttle position and manifold pressure for said vehicle are increasing and road speed and engine speed for said vehicle are decreasing.

13. Apparatus for optimizing operation of a vehicle, comprising:

a plurality of sensors coupled to a vehicle having an engine, said plurality of sensors, which collectively monitor operation of said vehicle, including a road speed sensor, an engine speed sensor, a manifold pressure sensor and a throttle position sensor;

a processor subsystem, coupled to each one of said plurality of sensors, to receive data therefrom;

a memory subsystem, coupled to said processor subsystem, said memory subsystem storing therein a manifold pressure set point, an engine speed set point and present and prior levels for each one of said plurality of sensors;

a fuel overinjection notification circuit coupled to said processor subsystem, said fuel overinjection notification circuit issuing a notification that excessive fuel is being supplied to said engine of said vehicle;

an upshift notification circuit coupled to said processor subsystem, said upshift notification circuit issuing a notification that said engine of said vehicle is being operated at an excessive engine speed;

a downshift notification circuit coupled to said processor subsystem, said downshift notification circuit issuing a notification that said engine of said vehicle is being operated at an insufficient engine speed;

said processor subsystem determining, based upon data received from said plurality of sensors, when to activate said fuel overinjection circuit, said upshift notification circuit and said downshift notification circuit.

14. Apparatus for optimizing operation of a vehicle according to claim 13 wherein:

said fuel overinjection circuit further comprises a first horn for issuing a first tone for a first preselected time period;

said upshift notification circuit further comprises a second horn for issuing a second tone for a second preselected time period; and

said downshift notification circuit further comprises a third horn for issuing a third tone for a third preselected time period.

15. Apparatus for optimizing vehicle performance according to claim 13 wherein said processor subsystem further comprises:

means for determining when road speed for said vehicle is increasing or decreasing

means for determining when throttle position for said vehicle is increasing;

means for comparing manifold pressure to said manifold pressure set point;

means for comparing engine speed to said RPM set point;

5,954,781

17

means for determining when manifold pressure is increasing; and

means for determining when engine speed is increasing or decreasing;

said processor subsystem activating said fuel overinjection notification circuit if both road speed and throttle position for said vehicle are increasing and manifold pressure for said vehicle is above said manifold pressure set or if both throttle position and manifold pressure for said vehicle are increasing and road speed and engine speed for said vehicle are decreasing;

said processor subsystem activating said upshift notification circuit if both road speed and throttle position for said vehicle are increasing, manifold pressure for said vehicle is at or below said manifold pressure set point and engine speed for said vehicle is at or above said RPM set point; and

said processor subsystem activating said downshift notification circuit if both road speed and engine speed are decreasing and both throttle position and manifold pressure for said vehicle are increasing.

16. Apparatus for optimizing operation of a vehicle according to claim 15 wherein:

said fuel overinjection circuit further comprises a first horn for issuing a first tone for a first preselected time period;

said upshift notification circuit further comprises a second horn for issuing a second tone for a second preselected time period; and

said downshift notification circuit further comprises a third horn for issuing a third tone for a third preselected time period.

17. Apparatus for optimizing operation of a vehicle, comprising:

a radar detector, said radar detector determining a distance separating a vehicle having an engine and an object in front of said vehicle;

at least one sensor coupled to said vehicle for monitoring operation thereof, said at least one sensor including a road speed sensor, a manifold pressure sensor, a throttle position sensor and an engine speed sensor;

a processor subsystem, coupled to said radar detector and said at least one sensor, to receive data therefrom;

a memory subsystem, coupled to said processor subsystem, said memory subsystem storing a first vehicle speed/stopping distance table, a manifold pressure set point, an RPM set point, a present level for each one of said at least one sensor and a prior level for each one of said at least one sensor;

a vehicle proximity alarm circuit coupled to said processor subsystem, said vehicle proximity alarm circuit issuing an alarm that said vehicle is too close to said object;

a fuel overinjection circuit coupled to said processor subsystem, said fuel overinjection circuit issuing a notification that excessive fuel is being supplied to said engine of said vehicle;

an upshift notification circuit coupled to said processor subsystem, said upshift notification circuit issuing a notification that said engine of said vehicle is being operated at an excessive speed;

said processor subsystem determining, based upon data received from said radar detector, said at least one sensor and said memory subsystem, when to activate

18

said vehicle proximity alarm circuit, when to activate said fuel overinjection circuit, and when to activate said upshift notification circuit.

18. Apparatus for optimizing operation of a vehicle according to claim 17 wherein:

said at least one sensor further includes a windshield wiper sensor for indicating whether a windshield wiper of said vehicle is activated; and

said memory subsystem further storing a second vehicle speed/stopping distance table.

19. Apparatus for optimizing operation of a vehicle according to claim 17 and further comprising:

a throttle controller for controlling a throttle of said engine of said vehicle; and

said processor subsystem selectively reducing said throttle based upon data received from said radar detector, said at least one sensor and said memory subsystem.

20. Apparatus for optimizing operation of a vehicle according to claim 19 wherein said at least one sensor further includes a brake sensor for indicating whether a brake system of said vehicle is activated.

21. Apparatus for optimizing operation of a vehicle according to claim 19 wherein said processor subsystem further comprises:

means for counting a total number of vehicle proximity alarms determined by said processor subsystem;

means for selectively reducing said throttle based upon said total number of vehicle proximity alarms.

22. Apparatus for optimizing operation of a vehicle according to claim 17 and further comprising:

a downshift notification circuit coupled to said processor subsystem, said downshift notification circuit issuing a notification that said engine of said vehicle is being operated at an insufficient engine speed; and

said processor subsystem determining, based upon data received from said plurality of sensors, when to activate said downshift notification circuit.

23. Apparatus for optimizing operation of a vehicle, comprising:

a radar detector, said radar detector determining a distance separating a vehicle having an engine and an object in front of said vehicle;

a plurality of sensors coupled to a vehicle having an engine, said plurality of sensors, which collectively monitor operation of said vehicle, including a road speed sensor, and engine speed sensor, a manifold pressure sensor and a throttle position sensor;

a processor subsystem, coupled to said radar detector and each one of said plurality of sensors, to receive data therefrom;

a memory subsystem, coupled to said processor subsystem, said memory subsystem storing therein a first vehicle speed/stopping distance table, a manifold pressure set point, an RPM set point, and present and prior levels for each one of said plurality of sensors;

a fuel overinjection notification circuit coupled to said processor subsystem, said fuel overinjection notification circuit issuing a notification that excessive fuel is being supplied to said engine of said vehicle;

an upshift notification circuit coupled to said processor subsystem, said upshift notification circuit issuing a notification that said engine of said vehicle is being operated at an excessive engine speed;

said processor subsystem determining, based upon data received from said plurality of sensors, when to activate

5,954,781

19

vate said fuel overinjection circuit and when to activate said upshift notification circuit;

a vehicle proximity alarm circuit coupled to said processor subsystem, said vehicle proximity alarm circuit issuing an alarm that said vehicle is too close to said object;

said processor subsystem determining, based upon data received from said radar detector, said at least one sensor and said memory subsystem, when to activate said vehicle proximity alarm circuit.

24. Apparatus for optimizing operation of a vehicle according to claim 23 wherein said processor subsystem further comprises:

means for determining when road speed for said vehicle is increasing or decreasing;

means for determining when throttle position for said vehicle is increasing or decreasing; and

means for comparing manifold pressure to said manifold pressure set point;

means for determining when manifold pressure for said vehicle is increasing or decreasing; and

means for determining when engine speed for said vehicle is increasing or decreasing;

said processor subsystem activating said fuel overinjection notification circuit if both road speed and throttle position for said vehicle are increasing and manifold pressure for said vehicle is above said manifold pressure set point or if both throttle position and manifold pressure for said vehicle are increasing and road speed and engine speed for said vehicle are decreasing.

25. Apparatus for optimizing operation of a vehicle according to claim 23 wherein said processor subsystem further comprises:

means for determining when road speed for said vehicle is increasing;

means for determining when throttle position for said vehicle is increasing;

means for comparing manifold pressure to said manifold pressure set point; and

means for comparing engine speed to said RPM set point;

said processor subsystem activating said upshift notification circuit if both road speed and throttle position for said vehicle are increasing, manifold pressure for said vehicle is at or below said manifold pressure set point and engine speed for said vehicle is at or above said RPM set point.

26. Apparatus for optimizing operation of a vehicle, comprising:

a radar detector, said radar detector determining a distance separating a vehicle having an engine and an object in front of said vehicle;

a plurality of sensors coupled to a vehicle having an engine, said plurality of sensors, which collectively monitor operation of said vehicle, including a road speed sensor, and engine speed sensor, a manifold pressure sensor and a throttle position sensor;

a processor subsystem, coupled to said radar detector and each one of said plurality of sensors, to receive data therefrom;

a memory subsystem, coupled to said processor subsystem, said memory subsystem storing therein a first vehicle speed/stopping distance table, a manifold pressure set point, RPM set point, and present and prior levels for each one of said plurality of sensors;

20

a fuel overinjection notification circuit coupled to said processor subsystem, said fuel overinjection notification circuit issuing a notification that excessive fuel is being supplied to said engine of said vehicle;

a downshift notification circuit coupled to said processor subsystem, said downshift notification circuit issuing a notification that said engine of said vehicle is being operated at an insufficient engine speed;

said processor subsystem determining, based upon data received from said plurality of sensors, when to activate said fuel overinjection circuit and when to activate said downshift notification circuit;

a vehicle proximity alarm circuit coupled to said processor subsystem, said vehicle proximity alarm circuit issuing an alarm that said vehicle is too close to said object;

said processor subsystem determining, based upon data received from said radar detector, said at least one sensor and said memory subsystem, when to activate said vehicle proximity alarm circuit.

27. Apparatus for optimizing operation of a vehicle according to claim 26 wherein said processor subsystem further comprises:

means for determining when road speed for said vehicle is decreasing;

means for determining when throttle position for said vehicle is increasing;

means for determining when manifold pressure for said vehicle is increasing; and

means for determining when engine speed for said vehicle is decreasing;

said processor subsystem activating said downshift notification circuit if both road speed and engine speed are decreasing and both throttle position and manifold pressure for said vehicle are increasing.

28. Apparatus for optimizing operation of a vehicle, comprising:

a plurality of sensors coupled to a vehicle having an engine, said plurality of sensors, which collectively monitor operation of said vehicle, including a road speed sensor, a manifold pressure sensor and a throttle position sensor;

a processor subsystem, coupled to each one of said plurality of sensors, to receive data therefrom;

a fuel overinjection notification circuit coupled to said processor subsystem, said fuel overinjection notification circuit issuing a notification that excessive fuel is being supplied to said engine of said vehicle;

said processor subsystem determining whether to activate said fuel overinjection notification sensor based upon data received from said road speed sensor, said throttle position sensor and said manifold pressure sensor.

29. Apparatus according to claim 28 and further comprising:

a memory subsystem, coupled to said processor subsystem, said memory subsystem maintaining a manifold pressure set point;

said processor subsystem activating said fuel overinjection notification circuit upon determining that:

(1) based upon data received from said road speed sensor, road speed of said vehicle is increasing;

(2) based upon data received from said throttle position sensor, throttle position for said vehicle is increasing; and

5,954,781

21

(3) based upon data received from said manifold pressure sensor, manifold pressure for said vehicle exceeds said manifold pressure set point.

30. Apparatus according to claim 28, wherein:

said plurality of sensors coupled to said vehicle further include an engine speed sensor;

said processor subsystem activating said fuel overinjection notification circuit upon determining that:

(1) based upon data received from said road speed sensor, road speed of said vehicle is decreasing;

(2) based upon data received from said throttle position sensor, throttle position for said vehicle is increasing;

(3) based upon data received from said manifold pressure sensor, manifold pressure for said vehicle is increasing; and

(4) based upon data received from said engine speed sensor, engine speed for said vehicle is decreasing.

31. Apparatus for optimizing operation of a vehicle, comprising:

a radar detector, said radar detector determining a distance separating a vehicle having an engine and an object in front of said vehicle;

at least one sensor coupled to said vehicle for monitoring operation thereof, said at least one sensor including a road speed sensor;

a processor subsystem, coupled to said radar detector and said at least one sensor, to receive data therefrom;

a memory subsystem, coupled to said processor subsystem, said memory subsystem storing a first vehicle speed/stopping distance table;

a vehicle proximity alarm circuit coupled to said processor subsystem, said vehicle proximity alarm circuit issuing an alarm that said vehicle is too close to said object;

22

said processor subsystem determining whether to activate said vehicle proximity alarm circuit based upon separation distance data received from said radar detector, vehicle speed data received from said road speed sensor and said first vehicle speed/stopping distance table stored in said memory subsystem.

32. Apparatus for optimizing operation of a vehicle according to claim 31 wherein:

said at least one sensor further includes a windshield wiper sensor for indicating whether a windshield wiper of said vehicle is activated; and

said memory subsystem further storing a second vehicle speed/stopping distance table;

if said windshield wiper sensor indicates that said windshield wiper is deactivated, said processor subsystem determining whether to activate said vehicle proximity alarm circuit based upon data received from said radar detector, said road speed sensor and said first vehicle speed/stopping distance table stored in said memory subsystem;

if said windshield wiper sensor indicates that said windshield wiper is activated, said processor subsystem determining whether to activate said vehicle proximity alarm circuit based upon data received from said radar detector, said road speed sensor and said second vehicle speed/stopping distance table stored in said memory subsystem.

\* \* \* \* \*

## **EXHIBIT 3**

[54] **TWO-CYCLE ENGINE WITH ELECTRONIC FUEL INJECTION**

4,821,210 4/1989 Howell et al. .... 364/551.01  
 4,823,290 4/1989 Fasack et al. .... 364/550  
 4,843,576 6/1989 Smith et al. .... 364/557

[75] Inventor: Ronald E. Chasteen, Lakeside, Ariz.

Primary Examiner—Raymond A. Nelli  
 Attorney, Agent, or Firm—Bruce G. Klaas; William P. O'Meara

[73] Assignee: Injection Research Specialists, Inc., Colorado Springs, Colo.

[21] Appl. No.: 345,081

[57] **ABSTRACT**

[22] Filed: Apr. 28, 1989

A fuel injection system for a two-stroke cycle engine comprising an air manifold; a throttle valve; a fuel injector; a fuel supply system including a fuel pump; a battery voltage sensor; an air temperature sensor; an engine speed sensor; a timing sensor; a barometric pressure sensor; a throttle position sensor; a first data processor for receiving and processing sensing signals for determining fuel injector duration and timing and fuel pump operating speed; a first data processor temperature sensor for sensing the relative temperature of certain electronic components in the first data processor; a heater operatively associated with the first data processor electronic components for selectively heating the electronic components; and a second data processor operable independently of the first data processor for receiving an electronic component temperature sensing signal and for generating a control signal to the heater responsive thereto for heating the components when the temperature thereof is below a predetermined minimum value.

**Related U.S. Application Data**

[63] Continuation of Ser. No. 119,626, Nov. 12, 1987, abandoned.

[51] Int. Cl.<sup>4</sup> ..... F02M 7/00; G05D 23/00

[52] U.S. Cl. .... 123/478; 364/557; 236/DIG. 8

[58] Field of Search ..... 123/478, 480, 73 A, 123/65 BA, 383, 502, 440, 492, 489; 364/186, 550, 557, 510, 555.01; 236/DIG. 8

[56] **References Cited**

**U.S. PATENT DOCUMENTS**

4,411,385	10/1983	Lamkewitz	.....	236/DIG. 8
4,607,962	8/1986	Nagao et al.	.....	364/557
4,675,826	6/1987	Gentry et al.	.....	364/557
4,739,492	4/1988	Cochran	.....	364/510
4,751,909	6/1988	Otobe	.....	123/492
4,753,204	6/1988	Kojima et al.	.....	123/440
4,763,629	8/1988	Okazaki et al.	.....	123/489
4,766,868	8/1988	Shibata	.....	123/440
4,805,122	2/1989	McDavid et al.	.....	364/557

1 Claim, 5 Drawing Sheets

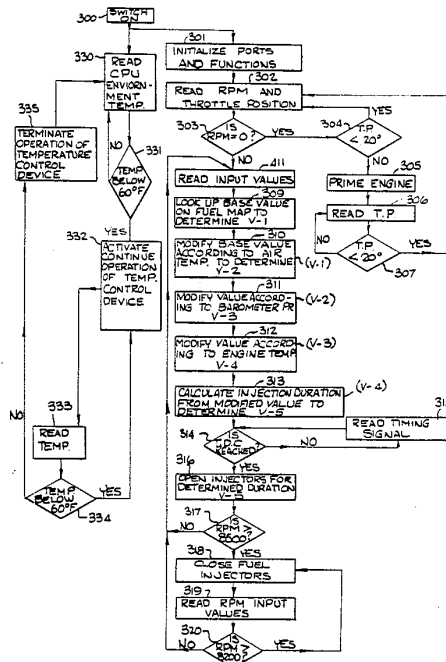

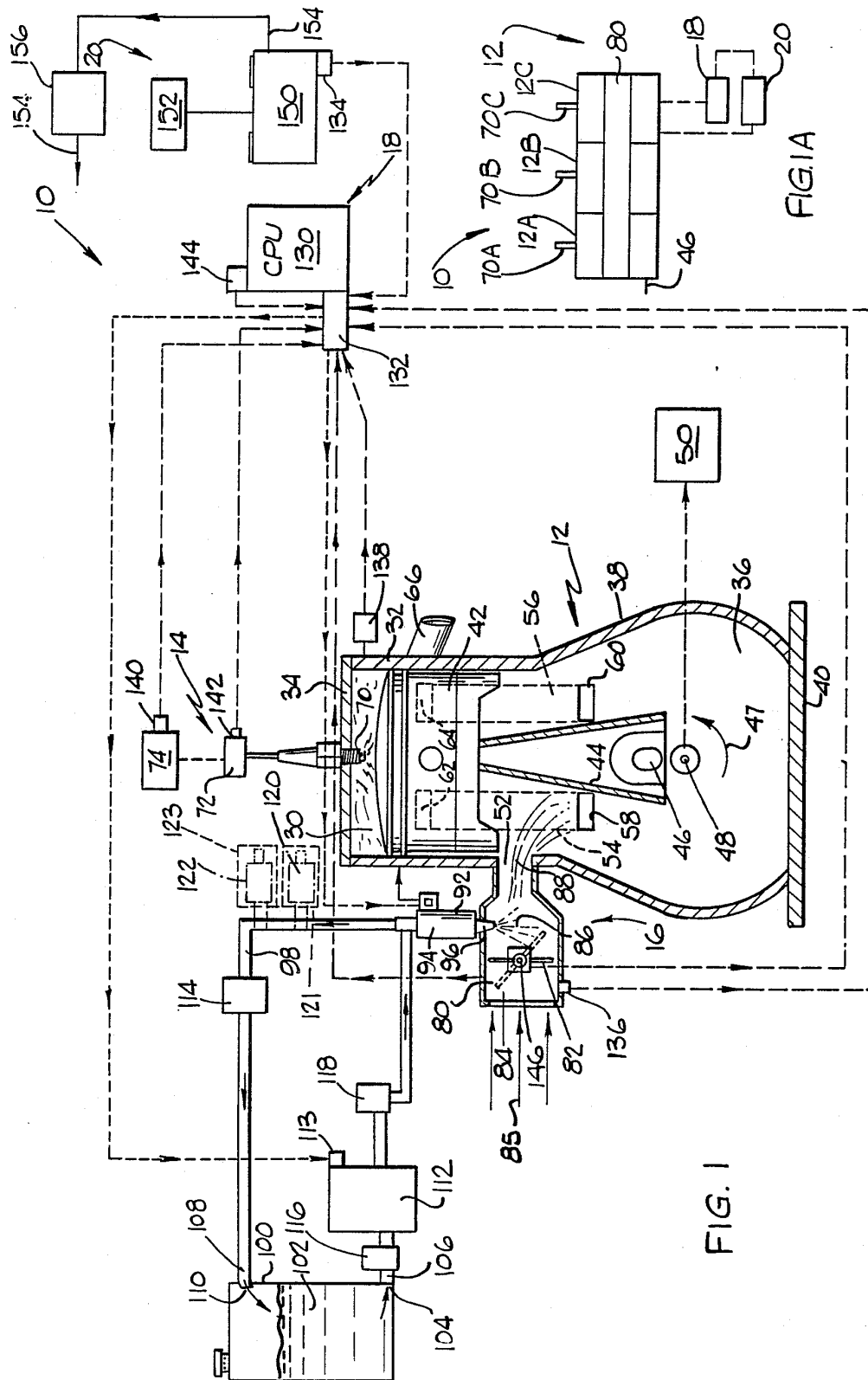

FIG. 1

FIG. 1A



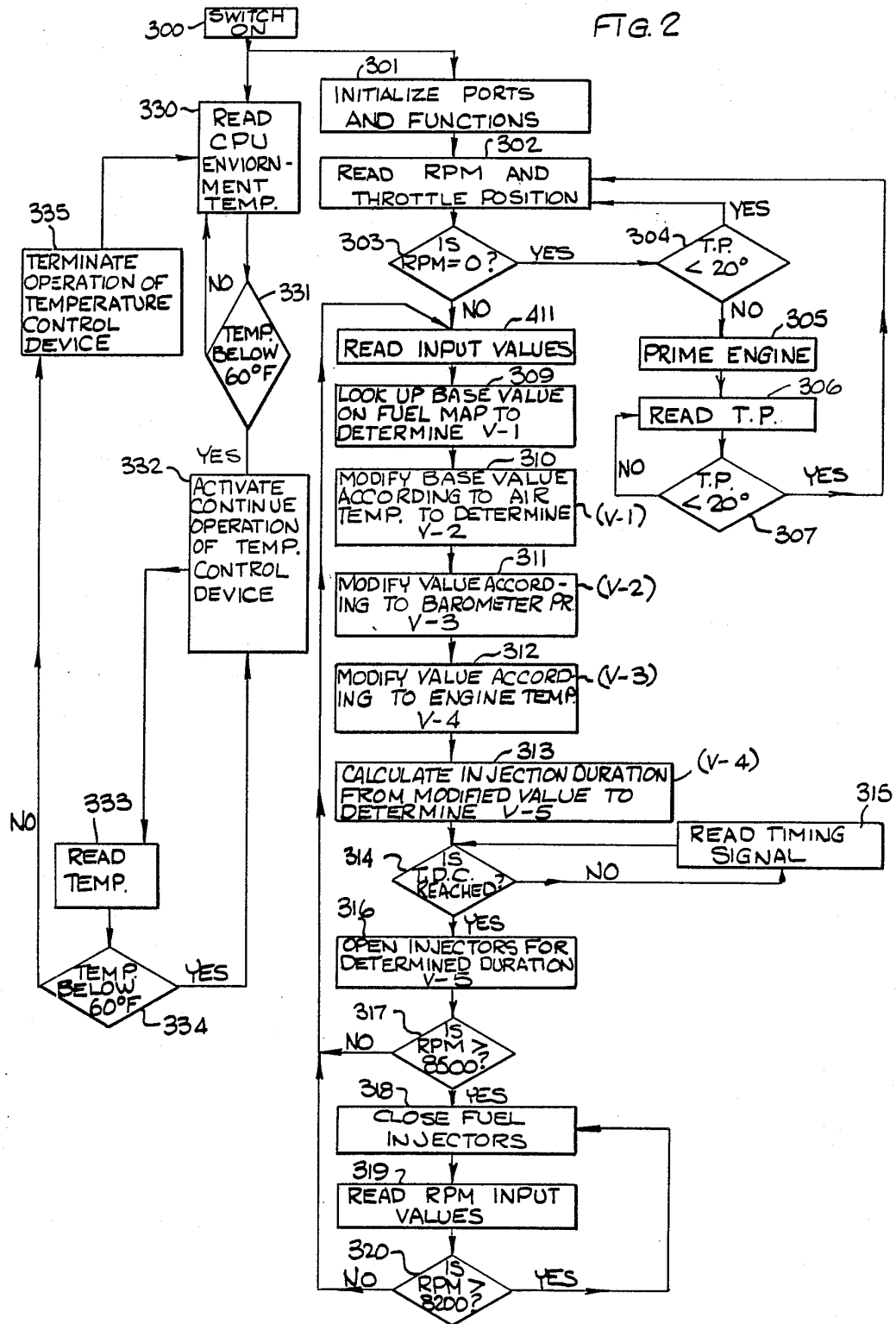

FIG. 3

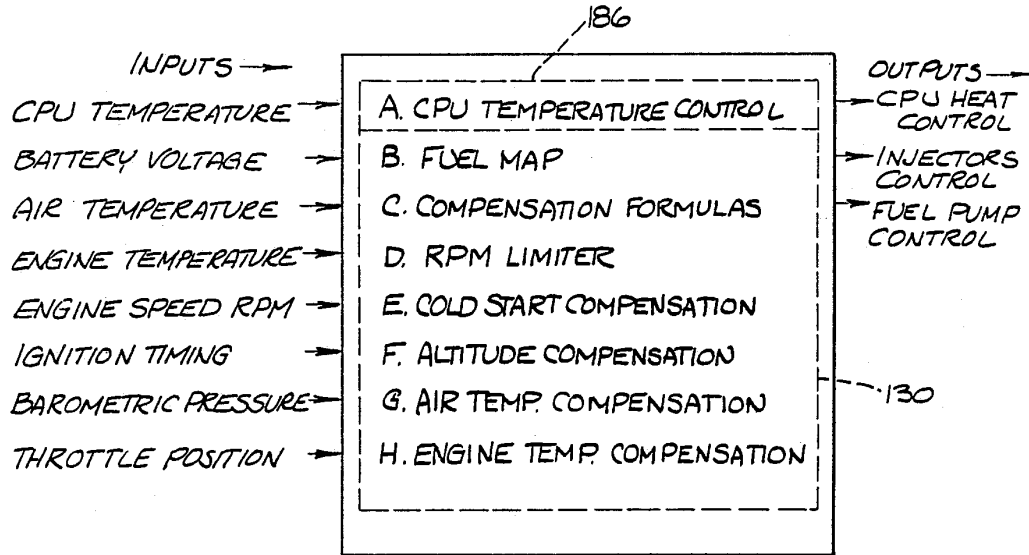

FIG. 4

THROTTLE POSITION NUMBER		RPM	
170	39	0	0
155	60	100	10
115	28	500	10
90	29	1000	10
75	25	1500	12
61	15	2000	12
52	10	2500	12
44	5	3000	12
37	2	3500	12
31	1	4000	12
25	1	4500	12
20	1	5000	12
16	1	5500	12
13	1	6000	12
10	1	6500	12
7	1	7000	12
4	1	7500	12
2	1	8000	12
1	1	8500	12
1	1	9000	12
1	1	9500	12
1	1	10000	12
1	1	10500	12
1	1	11000	12
1	1	11500	12
1	1	12000	12
1	1	12500	12
1	1	13000	12
1	1	13500	12
1	1	14000	12
1	1	14500	12
1	1	15000	12
1	1	15500	12
1	1	16000	12
1	1	16500	12
1	1	17000	12
1	1	17500	12
1	1	18000	12
1	1	18500	12
1	1	19000	12
1	1	19500	12
1	1	20000	12
1	1	20500	12
1	1	21000	12
1	1	21500	12
1	1	22000	12
1	1	22500	12
1	1	23000	12
1	1	23500	12
1	1	24000	12
1	1	24500	12
1	1	25000	12
1	1	25500	12
1	1	26000	12
1	1	26500	12
1	1	27000	12
1	1	27500	12
1	1	28000	12
1	1	28500	12
1	1	29000	12
1	1	29500	12
1	1	30000	12
1	1	30500	12
1	1	31000	12
1	1	31500	12
1	1	32000	12
1	1	32500	12
1	1	33000	12
1	1	33500	12
1	1	34000	12
1	1	34500	12
1	1	35000	12
1	1	35500	12
1	1	36000	12
1	1	36500	12
1	1	37000	12
1	1	37500	12
1	1	38000	12
1	1	38500	12
1	1	39000	12
1	1	39500	12
1	1	40000	12
1	1	40500	12
1	1	41000	12
1	1	41500	12
1	1	42000	12
1	1	42500	12
1	1	43000	12
1	1	43500	12
1	1	44000	12
1	1	44500	12
1	1	45000	12
1	1	45500	12
1	1	46000	12
1	1	46500	12
1	1	47000	12
1	1	47500	12
1	1	48000	12
1	1	48500	12
1	1	49000	12
1	1	49500	12
1	1	50000	12
1	1	50500	12
1	1	51000	12
1	1	51500	12
1	1	52000	12
1	1	52500	12
1	1	53000	12
1	1	53500	12
1	1	54000	12
1	1	54500	12
1	1	55000	12
1	1	55500	12
1	1	56000	12
1	1	56500	12
1	1	57000	12
1	1	57500	12
1	1	58000	12
1	1	58500	12
1	1	59000	12
1	1	59500	12
1	1	60000	12
1	1	60500	12
1	1	61000	12
1	1	61500	12
1	1	62000	12
1	1	62500	12
1	1	63000	12
1	1	63500	12
1	1	64000	12
1	1	64500	12
1	1	65000	12
1	1	65500	12
1	1	66000	12
1	1	66500	12
1	1	67000	12
1	1	67500	12
1	1	68000	12
1	1	68500	12
1	1	69000	12
1	1	69500	12
1	1	70000	12
1	1	70500	12
1	1	71000	12
1	1	71500	12
1	1	72000	12
1	1	72500	12
1	1	73000	12
1	1	73500	12
1	1	74000	12
1	1	74500	12
1	1	75000	12
1	1	75500	12
1	1	76000	12
1	1	76500	12
1	1	77000	12
1	1	77500	12
1	1	78000	12
1	1	78500	12
1	1	79000	12
1	1	79500	12
1	1	80000	12
1	1	80500	12
1	1	81000	12
1	1	81500	12
1	1	82000	12
1	1	82500	12
1	1	83000	12
1	1	83500	12
1	1	84000	12
1	1	84500	12
1	1	85000	12
1	1	85500	12
1	1	86000	12
1	1	86500	12
1	1	87000	12
1	1	87500	12
1	1	88000	12
1	1	88500	12
1	1	89000	12
1	1	89500	12
1	1	90000	12
1	1	90500	12
1	1	91000	12
1	1	91500	12
1	1	92000	12
1	1	92500	12
1	1	93000	12
1	1	93500	12
1	1	94000	12
1	1	94500	12
1	1	95000	12
1	1	95500	12
1	1	96000	12
1	1	96500	12
1	1	97000	12
1	1	97500	12
1	1	98000	12
1	1	98500	12
1	1	99000	12
1	1	99500	12
1	1	100000	12

FIG. 5

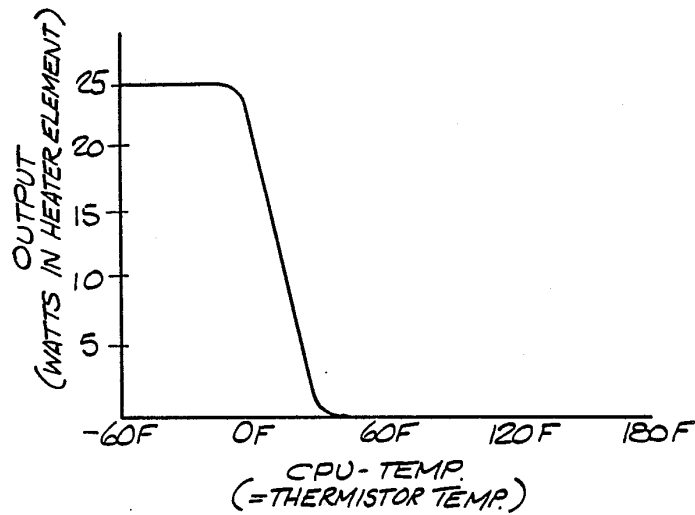
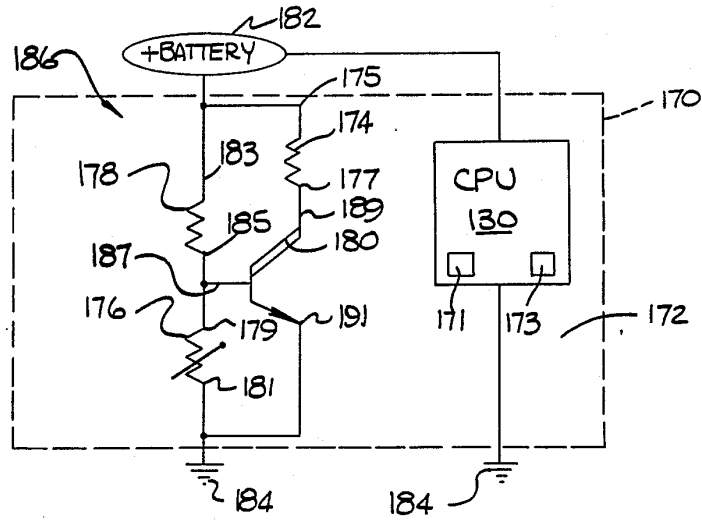

FIG. 6

## TWO-CYCLE ENGINE WITH ELECTRONIC FUEL INJECTION

The present application is a continuation of U.S. patent application Ser. No. 119,626 filed Nov. 12, 1987.

### BACKGROUND OF THE INVENTION

The present invention relates generally to two-stroke operating cycle engines and, more particularly, to a two-stroke engine fuel injection system and control system therefor which are adapted for extreme weather conditions.

Two-stroke operating cycle engines (two-cycle engines), although less fuel-efficient than four-stroke operating cycle engines (four-cycle engines), are capable of developing greater horsepower and torque than a comparably-sized four-cycle engine. This feature has led to the use of two-cycle engines in many environments in which operating efficiency is secondary to torque and weight considerations.

Electronically-controlled fuel injection is widely used in four-cycle engines. In electronic fuel injection used in four-cycle engines, sensor readings associated with various engine operating parameters are used to calculate an optimum fuel/air mixture for the engine. Fuel is then injected directly into the engine's cylinders in the proper amount based upon this electronically determined fuel/air mixture. In some four-cycle engine fuel injection systems, the fuel is injected into an air plenum upstream of the cylinder and is subsequently allowed to enter the cylinder with the plenum air through operation of an intake valve. Electronic fuel injection systems have replaced conventional carburetors in many four-cycle engines, especially in the automotive industry. However, fuel injection is not in general use with two-cycle engines and has not heretofore been used with small-displacement two-cycle engines which are used under severe cold weather conditions, for a number of reasons. Small two-cycle engines are used in association with equipment that is relatively inexpensive as compared to automobiles and other machines with which electronic fuel injection has been widely used in the past. In relatively large, expensive machinery, the cost associated with modifying basic engine components to enable internal mounting of various engine parameter sensors may be justified by increased fuel savings and engine performance and may amount to a relatively small portion of the purchase price of such an automobile, etc. In smaller engine environments, the cost of internal engine modification to existing engine assemblies would, in most cases, far outweigh any fuel savings which might be achieved by an electronic fuel injection unit and would represent a substantial increase in the cost of the associated small machine, e.g. snowmobile, dirt bike, etc., powered by the two-cycle engine.

Fuel injection systems without electronic controls have been used on two-cycle engines, but have not been satisfactory on small-displacement, small-mass two-cycle engines. The reason that fuel injection without electronic control has not been used successfully in small two-cycle engines is that such engines lack flywheels and other high-mass rotating components which tend to stabilize engine operation. Due to this lack of a large rotating mass in such engines, even a short duration mismatch between the rate at which fuel is actually delivered to the engine and the optimum engine fuel

rate requirements will cause engine sputter or rapid deceleration and stalling. Small, two-cycle engines are especially subject to malfunction under variable operating conditions such as changes in sea level, with associated barometric changes and changes in ambient air temperature. Many machines such as snowmobiles, snowblowers, dirt bikes, etc., are operated in such widely variable operating conditions. In view of the costs associated with engine modification for sensors' need for electronic control of fuel injectors and in view of the fact that the engine parameters which are critical to control of fuel injectors for two-cycle engines were not, prior to the present invention, understood in the art, a successful electronically-controlled fuel injection system for small, two-cycle engines which are subject to extremes in operating conditions has not been developed in the prior art.

### OBJECTS OF THE INVENTION

It is an object of the present invention to provide an electronic fuel injection system for a two-cycle engine which requires no internal modification to the basic engine assembly.

It is another object of the present invention to provide an electronic fuel injection control system which may be readily adapted for use with any conventional two-stroke cycle engine assembly.

It is another object of the present invention to provide a relatively small two-stroke cycle engine with electronic fuel injection which is capable of operation under variable and extreme conditions of air temperature and under widely varying barometric pressure conditions.

It is another object of the present invention to provide a fuel injection system for a two-cycle engine in which fuel injection takes place in an air manifold.

It is another object of the present invention to provide a fuel injection and control system for a two-cycle engine in which all fuel injectors simultaneously inject fuel into portions of an air manifold which are associated with individual cylinder/crankcases.

It is another object of the present invention to provide a control system for a electronic fuel injection system which utilizes relatively inexpensive electronic components and which is not subject to electronic component malfunction associated with low-temperature operation.

It is another object of the present invention to provide an electronic fuel injection system for a two-cycle engine which includes an electronically-stored fuel map indicative of the optimum fuel requirements for the engine under standard operating conditions over variable engine speed conditions and variable throttle conditions.

It is another object of the present invention to provide an electronic fuel injection system which provides a selected set of operating condition sensor inputs which do not require internal engine unit modifications and which provide optimized engine performance.

### SUMMARY OF THE INVENTION

The present invention is directed to an electronic fuel injection system for a small two-cycle engine. One aspect of the invention is a temperature control assembly which is operably associated with an electronic central processing unit of the type having electronic components which are subject to malfunction under low temperature conditions. The electronic components of the

heating assembly are not subject to malfunction under low temperature conditions and are designed to produce a heating response which is inversely proportional to temperature below a predetermined threshold temperature. The heating assembly is preferably mounted within a relatively small enclosure which also houses the electronic control system central processing unit. The heating assembly senses the temperature within the relatively small enclosure and rapidly heats electronic components within the relatively small enclosure to a predetermined temperature in response to sensing an environmental temperature within the enclosure which is below the predetermined temperature. The heating system may be actuated at the same time the electronic control system is actuated such as by the turning of the ignition switch of an associated machine, such as a snowmobile, etc.

Another feature of the present invention is the provision of an electronically-controlled fuel injection system which has a plurality of sensor inputs which are limited to the sensor inputs which are critical to the operation of a two-cycle engine and which may be mounted externally of a main engine assembly comprising a cylinder crankcase, piston, and crankshaft exclusive of the carburetion/fuel injection system therefor. The electronically-controlled fuel injection system of the present invention may thus be used without modification of existing two-cycle engine assemblies and is controlled by a CPU which may include a programmable memory device such as an EPROM which may be selectively programmed for any particular engine assembly with which the electronic fuel injection system is to be used. Another feature of the invention is the injection of fuel from a fuel injector into a portion of an air manifold which is in direct fluid communication with the crankcase portion of each individual cylinder/crankcase assembly. This injection of fuel into a manifold upstream of a crankcase provides mixing of a precise amount of fuel and air prior to entry of fuel into the crankcase and also enables all fuel injectors to be opened and closed simultaneously, rather than being timed to the operation of each associated piston.

Thus, the present invention may comprise a control system for controlling the operation of a machine designed to be operated in a relatively broad air temperature, comprising: (a) at least one performance variable sensing means for sensing the present state of a preselected variable associated with machine performance and for generating a performance variable sensing signal indicative of said present state of said preselected performance variable; (b) a first data processing means for receiving and processing said performance variable sensing signal and for generating a control signal based upon the processing of said sensing signal for controlling at least one operating parameter of said machine; (c) said data processing means comprising at least one temperature-sensitive electronic circuit component which is subject to malfunction below a predetermined malfunction temperature which is within said relatively broad operating temperature range of said machine; (d) a component environment temperature sensing means for sensing the temperature within the immediate operating environment of said temperature-sensitive electronic circuit component and for generating a temperature signal representative of the sensed temperature; (e) a second data processing means which operates independently of said first data processing means and which is not subject to temperature-related malfunction within

said operating temperature range of said machine for processing said signal from said component environment temperature sensing means and generating a heating control signal responsive thereto when the temperature in said electronic circuit environment is sensed to be below said predetermined malfunction temperature; (e) heating means responsive to said heating control signal for heating said temperature sensitive electronic component environment in response to said control signal; (f) power supply means for providing electric energy for operating said control system; (g) switch means for selectively operably electrically connecting or disconnecting said energy supply means and electrically operated components of said control system.

The present invention may also comprise a fuel injection system for a two-stroke cycle engine of the type comprising at least one cylinder, a crankcase associated with said cylinder, a piston reciprocally mounted in said cylinder and crankcase; a reciprocally openable and closable crankcase inlet for enabling combustible fluid to be drawn into the crankcase, a reciprocally openable and closable transfer port for transferring combustible fluid compressed in said crankcase to said cylinder, an ignition system for igniting compressed combustible fluid in said cylinder, a reciprocally openable and closable exhaust port in said cylinder for enabling exhaust of burned combustible fluid from said cylinder, a crankshaft connected to said piston for transferring mechanical energy from said piston to a drive unit, and an electrical energy supply source including a battery for operating the ignition system and other electrical components, comprising: (a) air manifold means operably associated with said crankcase inlet; (b) throttle valve means operably positioned in said air manifold means for controlling airflow into said crankcase inlet, said throttle valve means dividing said manifold means into an upstream portion positioned remote from said crankcase inlet and a downstream portion positioned contiguously with said crankcase inlet; (c) fuel injection means for injecting a fine spray of fuel into said downstream portion of said manifold means whereby a mixture of air and fuel is provided in said downstream portion of said manifold means which is subsequently drawn into said crankcase through said crankcase inlet; (d) fuel supply means for supplying fuel to said fuel injection means comprising: (i) fuel reservoir means for holding a volume of fuel therein and having a reservoir inlet and a reservoir outlet; (ii) fuel circulation conduit means for transferring fuel from said fuel reservoir to said fuel injection means comprising a first end inlet in fluid communication with said fuel reservoir outlet, a second end outlet in fluid communication with said fuel reservoir inlet and an intermediately positioned fuel injection outlet positioned in fluid communication with said fuel injection means; (iii) fuel pump means operatively associated with circulation conduit means at a position thereon between said conduit means first end inlet and said conduit means fuel injector outlet for pumping fuel through said circulating conduit; (iv) pressure limiting regulator means operatively associated with said circulation conduit means at a position thereon between said conduit means fuel injector outlet and said conduit means second end outlet for preventing pressure in said conduit means from exceeding a predetermined maximum pressure; (e) battery voltage sensing means for sensing battery voltage and for providing a battery voltage sensing signal representative thereof; (f) air temperature sensing means for sensing the temperature

of air in said upstream portion of said manifold means and for providing an air temperature signal representative thereof; (g) engine speed sensing means for sensing the speed of revolution of said engine and for providing an engine speed signal representative thereof; (h) timing sensing means for sensing each occurrence of a predetermined cyclically repeating state of said engine and for providing a timing signal indicative thereof; (i) barometric pressure sensing means for sensing atmospheric air pressure and for generating a barometric pressure sensing signal representative thereof; (j) throttle position sensing means for sensing the relative amount of opening of said throttle valve means and for generating a throttle position signal representative thereof; (k) first data processing means for receiving and processing said sensing signals comprising: (i) means for processing said engine speed sensing signal and said throttle position sensing signal and for generating a priming control signal to said fuel injection means for selectively injecting or not injecting fuel into said manifold means based on said engine speed signal and said throttle position signal; (ii) means for receiving and processing said engine speed signal and throttle position signal for determining a base fuel injection value; (iii) means for receiving and processing said air temperature signal and calculating an air temperature modification value of said base fuel injection value; (iv) means for receiving and processing said barometric pressure sensing signal for calculating a barometric pressure modification value of said base fuel injection value; (v) means for receiving and processing said engine temperature signal for calculating an engine temperature modification value of said base fuel injection value; (vi) means for determining a total fuel injection value representative of the total fuel amount which is to be injected by said fuel injection means during a single two-stroke operating cycle of said piston from said base fuel injection value, said air temperature modification value, said barometric pressure modification value, and said engine temperature modification value; (vii) means for determining an injector open duration interval based on said total fuel injection value and a known fuel output rate capacity of said fuel injection means; (viii) means for generating a control signal for opening said injection means for said determined injector duration open interval at a predetermined point in time determined from said timing sensing signal; (ix) means for receiving and processing said engine speed signal for overridingly terminating fuel injection means operation in response to an engine speed sensing signal indicative of a predetermined maximum speed and for restoring fuel injection means operation in response to an engine speed sensing signal indicative of a predetermined restore operation speed lower than said predetermined maximum speed; (x) means for receiving and processing said engine speed sensing signal and for generating a pump control signal in response thereto for maintaining said pump at an optimum operating speed for providing said predetermined maximum operating pressure in said fuel circulation conduit means at said pump; (l) first data processing means temperature sensing means for sensing the relative temperature of certain electronic components in said first data processing means and providing a component temperature sensing signal indicative thereof; (m) heating means operative associated with said first data processing means electronic components for selectively heating said electronic components; (n) second data processing means operable independently of said first data process-

ing means for receiving said electronic component temperature sensing signal and for generating a control signal to said heating means responsive to said component temperature sensing signal for heating said components when the temperature thereof is below a predetermined minimum value.

#### BRIEF DESCRIPTION OF THE DRAWING

An illustrative and presently preferred embodiment of the invention is shown in the accompanying drawing in which:

FIG. 1 is a schematic illustration of a two-stroke cycle engine with electronically-controlled fuel injection.

FIG. 1A is a schematic illustration of the engine of FIG. 1 showing additional cylinder portions thereof.

FIG. 2 is a flow chart illustrating operations of the electronic control unit of the present invention including the operation of the central processing unit and also the operation of a central processing unit temperature control assembly.

FIG. 3 is a diagram illustrating sensor inputs and control signal outputs and basic functions performed by an electronic control unit.

FIG. 4 is a typical engine fuel map expressed in rectangular coordinates.

FIG. 5 is a schematic illustration of an electronic control unit for a fuel injection system.

FIG. 6 is a graph of heater output as a function of CPU temperature for a typical CPU temperature control assembly of the type illustrated in FIG. 5.

#### DETAILED DESCRIPTION OF THE INVENTION

A two-stroke engine unit 10 of the present invention is shown schematically in FIG. 1. In general, the two-stroke cycle engine unit 10 comprises an engine assembly 12, an ignition assembly 14, a fuel/air input assembly 16, an electronic control assembly 18 and an electrical power supply assembly 20.

#### ENGINE ASSEMBLY

The engine assembly 12 illustrated in FIG. 1 is of a type which is conventional and well known in the art. The engine assembly comprises a cylinder cavity 30 which is generally referred to in the art simply as a cylinder. The cylinder cavity is defined by a cylindrical sidewall 32 and a circular top wall 34 which is fixedly attached to the sidewall 32. The engine assembly also comprises a generally pear-shaped crankcase cavity 36 which is generally referred to in the art simply as a crankcase. The crankcase cavity is defined by a crankcase sidewall 38 which is fixedly connected at the upper portion thereof to a lower portion of cylindrical sidewall 32. The crankcase wall is fixedly connected at a lower portion thereof to a base plate 40. The cylindrical cavity 30 and crankcase cavity 36 thus provide the upper and lower portions of a continuous total engine cavity. A cylindrical piston 42 is slidingly mounted in cylindrical cavity 30 and is pivotally attached to a connecting rod 44 which is, in turn, pivotally attached to a portion of crankshaft 46 which rotates, as indicated at 47, about a crankshaft central axis of rotation 48. The reciprocal motion of piston 42 within cylinder 30 is transferred by connecting rod 44 and crankshaft 46 to a conventional drive assembly 50 of an associated machine such as, for example, a snowmobile 12.

A fuel/air mixture which is sometimes referred to herein as combustion fluid or combustion material is drawn into the crankcase 36 through a combustion fluid inlet 52 sometimes referred to herein as an intake port 52. The intake port 52 is positioned at an upper portion of crankcase 36 and is cyclically opened and closed by reciprocation of piston 42. Transfer passages 54, 56, etc., having crankshaft transfer passage openings 58, 60, etc., and cylinder transfer port openings 62, 64, etc., enable transfer of compressed combustion fluid within the crankcase 36 to the cylinder 30. The cylinder transfer passage openings 62, 64, etc., are cyclically opened and closed through reciprocal motion of piston 42. A cylinder exhaust gas outlet 66 sometimes referred to herein as exhaust port 66 is provided in the cylinder sidewall 32 to discharge burned combustion fluid from cylinder 30. Exhaust port 66 is also cyclically opened and closed by reciprocation of piston 42. The engine assembly may comprise a plurality of cylinder/crankcase/piston assemblies identical to those described above which are operably connected to common crankshaft 46.

The mechanical operation of the two-cycle engine assembly, in general, is as follows. During upward motion of piston 42, crankcase intake port 52 is progressively opened and cylinder transfer passage openings 62, 64 and cylinder exhaust port 66 are progressively closed causing fuel/air mixture to be drawn into crankcase 3 through port 52 and causing fluid air mixture in cylinder 30 to be retained therein and progressively compressed. When the piston 42 reaches approximately its upward limit of motion or "top dead center" (T.D.C.), sparkplug 70 ignites the fuel/air mixture driving piston 42 downwardly. During the downward movement of the piston, cylinder exhaust port 66 is progressively opened, cylinder transfer port openings 62 and 64 are progressively opened and crankcase inlet 52 is progressively closed causing fuel/air mixture within the crankcase to be compressed and forced through the transfer passages 54, 56 into cylinder 30. The inflow of fresh fuel/air mixture into cylinder 30 is physically channeled into the cylinder in a manner to drive out burned exhaust gas within the cylinder out through exhaust port 66. During the subsequent upward movement of the piston 42, the abovedescribed cylinder fuel/air compression and crankcase fuel/air intake is again repeated, etc.

#### Ignition Assembly

Ignition assembly 14 comprises a conventional sparkplug mounted within cylinder 34 for igniting the fuel/air mix therein. Sparkplug 70 is conventionally connected to an ignition coil 72 which is, in turn, conventionally connected to an electrical power supply 20 and conventional timing apparatus 74 which may be conventionally linked to crankshaft 46. In an engine assembly with a plurality of cylinder/crankcase/piston assemblies, each cylinder is provided with a spark plug.

#### Fuel Air Input Assembly

Fuel air input assembly 16 includes an air manifold 80 mounted in fluid communication with crankshaft intake port 52. A throttle valve 82, which in a preferred embodiment comprises a conventional butterfly valve, divides the air manifold 80 into an upstream portion 84 which is in fluid communication with atmospheric air 8 through conventional air filters, etc. (not shown) and a downstream manifold portion 86 which opens directly

into crankcase 36. In the case of a multiple cylinder engine, there may be a single manifold upstream portion and a plurality of downstream portions, one for each cylinder/crankcase. An electrically operated fuel injector 92 comprising a solenoid valve portion 94 and a gas jet nozzle portion 96 is mounted so as to discharge a gas spray into the downstream manifold portion 86 to produce a fuel/air mixture in the downstream manifold portion which is subsequently drawn into crankcase 36. The fuel injector may be of a convention commercial available type such as Bosch 280150-007 available from the Robert Bosch Company, or NAPA 217514 available from Echlin, Inc., Branford, Conn., 06405. The fuel injector 92 is connected at the solenoid valve end thereof to a fuel circulation conduit 98 which is in fluid communication with a fuel reservoir 102 in fuel tank 100. The fuel circulation conduit comprises a conduit first end 104 connected to a fuel tank outlet 106 and a second end 108 connected to a fuel tank return inlet 110. An electric fuel pump 112 is provided for pumping fuel, such as gasoline, through the conduit 98. The electric fuel pump 112 is operably connected in fluid communication with the conduit at a point thereon between the fuel tank outlet 106 and the fuel injector 92. Conventional speed control circuitry 113 is provided to control the relative pumping speed of the fuel pump in response to a signal from the electronic control assembly 18 as discussed in further detail below. The fuel pump is conventionally connected to the electrical power supply assembly 20 from which it draws its operating energy. A conventional mechanically operated pressure limiting regulator 114 is operatively mounted in the fuel circulation conduit at a point between the fuel injector 92 and the fuel tank return inlet 110. Pressure regulator 114 prevents the fluid pressure in the circulating conduit from exceeding a predetermined maximum pressure which may be, e.g. 42 psia. A conventional coarse fuel filter 116 may be provided in the circulating conduit between fuel tank outlet 106 and fuel pump 112. A conventional fine fuel filter 118 may be provided in the circulating conduit between the fuel pump and injector 92. As shown in phantom in FIG. 1, the abovedescribed fuel system may be employed to provide fuel to further fuel injectors 120, 122 which are attached in fluid communication with the circulating conduit between the first fuel injector 92 and the pressure regulator 114. These fuel injectors 120, 122 may be mounted in manifold assemblies which may be identical to manifold assembly 16 described above and which are in turn associated with ignition assemblies and cylinder/crankcase piston assemblies 121, 123 which may be identical to those described above and which may be operably connected to a common electronic control assembly 18 and electrical power supply assembly 20.

#### Electronic Control Assembly

Electronic control assembly 18 includes a central processing unit 130 described in further detail below which is operably connected to conventional interface circuitry 132 which may comprise conventional analog to digital (A/D) circuitry for converting analog sensor signal inputs to digital signal inputs and which may further comprise conventional digital to analog (D/A) interface circuitry used to convert digital CPU command signals to analog command signals which are used to control various engine operating components as described below.



The electronic control assembly comprises a number of sensors having sensor outputs which are provided to the CPU 130 through interface circuitry 132. These sensors may include a battery voltage sensor 134, an air temperature sensor 136, an engine temperature sensor 138, an engine speed sensor 140, an ignition timing sensor 142, a barometric pressure sensor 144, and a throttle position sensor 146. The battery voltage sensor may comprise a conventional sensor or current sensing circuit well-known in the art. The air temperature sensor 136 may comprise a T55101 NAPA sensor mounted in the engine manifold. The engine temperature sensor 138 is mounted on the cooling fins of an air-cooled engine or may comprise a TS 4000 NAPA mounted within the engine cooling water jacket of a liquid cooled engine. The engine speed sensor 140 may comprise a conventional electronic encoder mounted on the crankshaft or associate drive linkage. In such an engine speed sensor configuration, an engine speed value is determined by counting the number of encoder pulses occurring within a fixed time interval. This timing interval may be provided by an external clock pulse signal or a CPU internal clock signal. The ignition timing sensor 142 may comprise an electric signal sensor connected directly to the ignition coil 72 for sensing the time of ignition of each cylinder. In such an ignition timing sensor configuration, the CPU is programmed to respond to only one cylinder ignition pulse per engine revolution. Thus, for example, in a three cylinder engine, the CPU would respond to only the first ignition coil pulse in each three pulse set associated with a complete engine revolution. Similarly, the ignition timing sensor signal may be derived directly from encoder signal 140 simply through counting the number of encoder pulses which are associated with a single revolution of the engine and generating a timing pulse after the occurrence of such a predetermined number of encoder pulses.

Barometric pressure sensor 144 may be mounted in any convenient location where it is exposed to the atmosphere such as, for example, on the housing of the CPU 130. The barometric pressure sensor 144 may be any of a number of commercially available sensors such as a Motorola MPX 201. Throttle position 146 senses the relative amount of opening of the throttle butterfly valve 82 and may comprise a conventional potentiometer unit.

The CPU 130 receives and processes the signals from the various sensors described above and generates control signals which are used to control fuel pump speed, to maintain the speed of operation of the fuel pump at a rate which provides a pressure in the circulation conduit portion immediately downstream therefrom which is approximately equal to the preset maximum pressure of the pressure regulator 114. The CPU 130 also generates control signals which actuate the solenoid valve portion 94 of each fuel injector 92 to selectively open and close and injector to provide a proper amount of fuel injection into the manifold as determined by the CPU. The CPU 130 may also provide a number of other control functions as described in further detail below. The CPU 130, in a preferred embodiment of the invention, comprises a conventional microprocessor chip 171, FIG. 5, such as a Motorola 6502 and a conventional memory chip 173, FIG. 5, which may be a PROM or EPROM chip such as, for example, Motorola 2532.

The electronic control assembly may also comprise a CPU temperature control assembly. One embodiment

of such a temperature control system is illustrated in FIG. 5 in which CPU 130 is mounted within a relatively small, e.g. 10 cubic inches, CPU protective enclosure box 170 which defines a local CPU environmental enclosure 172. The box 170 may be 2.5 inches×5 inches×0.75 inches. Also positioned within the CPU environment enclosure are a conventional heating coil 174 having terminals 175, 177, which may have a resistance of 50 ohms, and a conventional thermistor 176, which may be, e.g., an NTC 750 ohm thermistor. The heater element and thermistor are connected as shown in an electronic circuit containing a second resistor 178 having terminals 183, 185 and having a resistance of 10,000 ohms, and a Darlington transistor 180 having a gate terminal 187, a collector terminal 189, and an emitter terminal 191, which may be a Motorola 6668 which may have an amplification of 400%. The circuit containing the circuit elements 174, 176, 178, 180 is connected to the positive pole of a battery 182 and a ground (or negative pole of a battery) 184. The battery 182 may also be used to provide power for CPU 130. Battery 182 may be same or different from the battery 150 used to provide energy to the engine ignition system, etc. The voltage drop across 182, 184 may be, e.g., 5 volts. The characteristics of the particular circuit elements 174, 176, 178, 180 may be selected to provide a heating energy response to particular temperature conditions such as indicated in FIG. 6 for rapidly heating the CPU environment 172 to a predetermined maximum threshold value such as 60° F. It will thus be seen that the heating circuit indicated generally at 186 is adapted to maintain the CPU at a temperature which is above a predetermined low temperature, e.g. 60° F., below which certain components of the CPU are subject to a greatly increased probability of malfunction. It will of course be appreciated that this predetermined temperature may be chosen to have a value well above a temperature at which malfunction is probable. A heating circuit such as illustrated at FIG. 5 may be provided relatively inexpensively and thus eliminates the need for expensive CPU chips which are adapted to be operable under low temperature conditions. The heating circuit such as illustrated at FIG. 5 is adapted to be particularly effective under conditions associated with the usage of snowmobiles and other winter operated machines such as snowblowers, etc.

#### Electric Power Supply

The engine electric power supply 20 may comprise conventional power supply components such as a battery 150 which may be a conventional 12-volt battery and other power generating devices such as alternator or generator which are represented schematically at 152. Power to the electronic control assembly 18, fuel input assembly 16, and other electrically-operated components may be provided through conventional conductors 154 operably connected to a switching assembly 156 which may be a snowmobile ignition switch, etc.

An engine unit comprising multiple cylinder/crankcase/piston assemblies 12A, 12B, 12C in engine assembly 12 and comprising an ignition assembly with multiple spark plugs 70A, 70B, 70 with a common crankshaft 146 and a common electronic control assembly 18 and a common power supply 20 is shown in FIG. 1A.

Having thus described the overall construction and operation of the two-stroke cycle engine unit 10 in

general, certain specific features of the electronic control assembly 18 will now be described in greater detail.

#### Control System Functions

The basic functional steps performed by the control assembly central processing unit 130 is illustrated in FIG. 2. As illustrated at 300, the control system becomes operational by switching the system on. In a typical use environment such as when the control system is used in associated with a snowmobile engine, step 300 would be performed by turning the snowmobile ignition switch to the "on" position. As illustrated at 301 switching the system on causes electrical energy to be provided to the CPU which initializes all ports and functions of the CPU. Next, the CPU reads the engine speed and throttle position which are indicated as RPM and T.P., respectively, in block 302. Next, as indicated in blocks 303-307, the CPU determines whether or not the engine is to be primed. The sequence of steps 302-307 comprises what will be referred to herein as a "cold start circuit". As indicated at 303, the CPU determines from the reading taken at 302 whether or not the engine RPM is greater than 0. If engine RPM is greater than 0, the CPU next makes the determination from the throttle position reading of 302 whether or not the throttle position is greater than a predetermined amount, such as 20°, as indicated in block 304. If throttle position is less than 20°, the CPU decision-making process returns to block 302. If the throttle position is greater than the predetermined amount and RPM=0, the CPU provides a control command to the engine fuel injector(s) to prime the engine. In a preferred embodiment of the invention, an engine priming pulse of a predetermined fixed duration associated with a predetermined fixed amount of fuel, e.g. 100 milliliters per injector, is sent to each fuel injector in response to a prime engine command from the CPU. After an initial engine priming function indicated at 305 has been performed, the CPU again reads throttle position as indicated at 306. After reading the throttle position, the CPU again determines whether or not the throttle position is greater than a predetermined amount such as 20°. If the throttle position is greater than 20°, then the CPU again returns to decision step 306 and repeats step 306, 307 until the throttle position is less than 20°. In a typical operating environment, this would be the equivalent of waiting for an operator to release an opened throttle lever/pedal. Once the throttle position is reduced to below 20°, as indicated at block 307, the CPU decision-making processing returns to block 302, causing the cold circuit decision-making process of blocks 302-307 to be repeated until engine RPM is greater than 0. After engine RPM becomes greater than 0, the CPU reads all of the input values from the various sensors, as shown schematically in FIG. 3.

Next, as indicated at 309, the CPU determines a base fuel value from a "fuel map" and the engine speed input and the throttle position input. A fuel map is prepared and stored in permanent memory of the CPU based upon the operating characteristics of the particular engine which is being controlled. The fuel map is prepared and stored in permanent CPU memory in an initial production step before the CPU is used to control the engine. A typical fuel map is illustrated in FIG. 3 in which the horizontal axis is indicative of engine RPM value and the vertical axis, as indicated at the right-hand side of the fuel map, is indicative of throttle position. Throttle position may be expressed, for example, in

angular degrees of throttle opening or may be expressed in assigned numbers relating, non-linearly, to throttle opening which enables a higher resolution of the fuel map in certain critical regions of an engine power curve. The data array shown in FIG. 3 indicates the optimum base fuel value in milliliters for an engine fuel injector single pulse under predetermined standard operating conditions for any given engine RPM and throttle position. For example, if the engine RPM is 6000 and the throttle position is 25, the optimum base fuel value as indicated from the fuel map is 20 milliliters under standard operating conditions. It will, of course, be appreciated that the information provided in the fuel map may be stored in various electronic forms such as in algorithm form as well as look-up table form. It will also be appreciated that the resolution of the fuel map may be provided to conform with the resolution of the RP and throttle position sensing signals and with the resolution requirements of the control system.

The base fuel value from the fuel map (FIG. 4) reading performed in block 309 and indicated as V-1 is stored in CPU memory and is modified in steps 310-313 based upon the various input values read in block 308. As indicated at block 310, the base fuel value is first modified based on the air temperature input. At a predetermined operating temperature, e.g. standard operation conditions of 70° F., no modification is performed. If the temperature is above or below this predetermined value, then the base fuel value is modified accordingly based upon a predetermined algorithm or look-up table which is stored in permanent memory. Algorithms for engine fuel requirement modification based upon ambient air temperature are well-known in the art. The modified base value determined based upon air temperature modification is indicated as V-2.

As indicated in block 311, the modified base value V-2 is next further modified based upon the barometric pressure reading. This modification may again be performed by use of a conventional algorithm or look-up table stored in permanent memory. The resulting modified fuel value is indicated as V-3.

As indicated in block 312, modified value V-3 is next further modified based upon engine temperature. The modified value is indicated as V-4. This modification may be made either from a stored algorithm or a stored look-up table which is prepared based upon the particular engine temperature operating characteristics of the subject engine.

Next, as indicated in block 313, the modified fuel value V-4, which is indicative of the total corrected (compensated) fuel amount that each injector should inject into the engine during each revolution thereof for optimum performance, is used to determine the duration of injector opening which is required to provide fuel injection in the amount of V-4 under predetermined fuel injector parameters, e.g. with a known, constant fixed fuel pressure and a known, fixed injector orifice size, etc. This duration is indicated at V-5 and may be expressed in milliseconds. An alternative to modifying base fuel value is sequential steps as described above in 310-312; relative correction factors may be simultaneously computed based on the variables indicated in 310-312 and a total correction factor may be derived therefrom and applied to the base fuel value to arrive at a total corrected fuel amount V-4.

Next, as illustrated in blocks 314 and 315, the CPU determines whether a predetermined cyclically reoccurring state (repeating once per engine revolution) of

the engine, such as, for example, a top dead center position of a selected one of the pistons, has been reached. Once that cyclically reoccurring engine state has been reached, the CPU provides a control command to the fuel injector(s) causing the fuel injector(s) to be opened for the predetermined length of time V-5 calculated in step 313. It will be appreciated that for a multiple cylinder engine the injectors may be opened sequentially at a predetermined spacing in time associated with the piston positions in the various cylinders, or all of the injectors may be opened simultaneously. In the preferred embodiment of the invention, all of the injectors are opened simultaneously due to the fact that, with the injection of fuel into the manifold, as opposed to conventional fuel injection into the crankcase, the sequential timing of injectors is unnecessary.

Next, as indicated in block 317, the engine RPM value from step 308 is compared to a predetermined maximum desired engine RPM such as, for example, 8500 RPM. If the engine speed is less than the predetermined maximum value, then the CPU again returns to operating step 308 and repeats steps 308-317. If the engine speed is greater than the predetermined value, then, as indicated in block 318, the CPU provides a control signal which closes the fuel injectors.

Next, as indicated in block 319, the CPU again reads the RPM input value. If the RPM input value is greater than a predetermined value which may be less than the maximum engine RPM (e.g. 8200 RPM), then the fuel injectors are retained in a closed position as indicated in step 318, and steps 319 and 320 are repeated. If the engine speed is less than 8200 RPM, then the CPU returns to step 308. Thus, once the engine reaches 8500 RPM, the fuel injectors are closed and remain closed until engine speed drops to 8200 RPM. This total termination of fuel as opposed to conventional speed control methods which simply reduce fuel injection amount or terminate ignition prevents damage to the engine or spark plug fouling associated with such prior art methods.

It will be understood by those with skill in the art that the total corrected (compensated) fuel value may be based on an average derived from several iterations of sensor inputs and total corrected fuel value calculations. It will also be appreciated that the actual fuel adjustments may be made at intervals less frequent than those in which total fuel value calculations are made, e.g. input readings and fuel value calculations may be made 100 times per second and total fuel injection duration may be adjusted 16 times per second.

The CPU 130 may also control pump speed based upon engine RPM. For example, at engine start up when RPM=0, the fuel pump may be actuated by a control signal from CPU 130 to cause it to run at full speed for one second and then stop until RPM is greater than zero. Above RPM=0, the CPU may cause the pump to run at 50% of its rated capacity (drawing one-half its normal maximum current amount) up to a predetermined engine speed, e.g. 3600 RPM. Above this predetermined speed, the CPU may cause the pump to operate at 100% of its rated capacity. Of course, more than two pumping rates may be provided, if desired, based upon a plurality of different engine RPM ranges. Such an arrangement, as well as providing optimum pressure, reduces energy draw on the electrical power supply at start-up and at low RPM.

As further indicated by FIG. 2, the switching on of the ignition, etc., at step 300 also operates a control

circuit which functions independently from the CPU 130 which performs the functions indicated in steps 300-320. In this independent circuit, as indicated at step 330, the temperature in the immediate environment of the chip components (e.g. microprocessor, EPROM, etc.) which comprise CPU 130 is initially determined. Next, as indicated at step 331, if the temperature within the CPU environment is greater than a predetermined temperature, such as, for example, 60° F., then the system returns to step 330 and cycles between 330 and step 331. When the temperature in the immediate operating environment of the CPU is sensed to be below the predetermined temperature, then the system actuates a temperature control device, such as a heating coil, to elevate the temperature in the environment of the CPU. Next, as indicated at step 333, the temperature within the operating environment is again read and compared to a predetermined temperature which may be the same or higher than the minimum temperature of step 331. If the temperature is below this second predetermined temperature, such as, e.g. 60° F., then the temperature control device continues to operate. If the temperature exceeds this second predetermined temperature, then the operation of the temperature control device is terminated and the system again returns to step 330.

It will be appreciated that these general control functions described in steps 330-335 apply to any system which is designed to maintain the temperature within a particular environment within a predetermined temperature range. Such temperature control could be performed by any number of conventional heating/air conditioning systems. In the presently preferred embodiment, a temperature control system which is not subject to malfunction at lowered temperatures, e.g. -60° F., is provided such as illustrated in FIG. 5 and discussed above.

All "Motorola" components indicated herein are commercially available from Motorola, Inc., 8201 E. McDowell Road, Scottsdale, Ariz., 85257-3812. All "NAPA" components indicated herein are commercially available from Echlin, Inc., Branford, Conn., 06405.

While an illustrative and presently preferred embodiment of the invention has been described in detail herein, it is to be understood that the inventive concepts may be otherwise variously embodied and employed and that the appended claims are intended to be construed to include such variations except insofar as limited by the prior art.

What is claimed is:

1. A fuel injection system for a two-stroke cycle engine of the type comprising at least one cylinder, a crankcase associated with said cylinder, a piston reciprocally mounted in said cylinder and crankcase; a reciprocally openable and closable crankcase inlet for enabling combustible fluid to be drawn into the crankcase, a reciprocally openable and closable transfer port for transferring combustible fluid compressed in said crankcase to said cylinder, an ignition system for igniting compressed combustible fluid in said cylinder, a reciprocally openable and closable exhaust port in said cylinder for enabling exhaust of burned combustible fluid from said cylinder, a crankshaft connected to said piston for transferring mechanical energy from said piston to a drive unit, and an electrical energy supply source including a battery for operating the ignition system and other electrical components, comprising:

15

- (a) fuel injection means for injecting fuel for combustion within said cylinder;
- (b) fuel supply means for supplying fuel to said fuel injection means;
- (c) battery voltage sensing means for sensing battery voltage and for providing a battery voltage sensing signal representative thereof;
- (d) air temperature sensing means for sensing the temperature of ambient air and for providing an air temperature signal representative thereof;
- (e) engine speed sensing means for sensing the speed of revolution of said engine and for providing an engine speed signal representative thereof;
- (f) timing sensing means for sensing each occurrence of a predetermined cyclically repeating state of said engine and for providing a timing signal indicative thereof;
- (g) barometric pressure sensing means for sensing atmospheric air pressure and for generating a barometric pressure sensing signal representative thereof;
- (h) throttle position sensing means for sensing the relative amount of opening of said throttle valve means and for generating a throttle position signal representative thereof;
- (i) first data processing means for receiving and processing said sensing signals comprising:
  - (i) means for processing said engine speed sensing signal and said throttle position sensing signal and for generating a priming control signal to said fuel injection means for selectively injecting or not injecting fuel into said manifold means based on said engine speed signal and said throttle position signal;
  - (ii) means for receiving and processing said engine speed signal and throttle position signal for determining a base fuel injection value;

40

45

50

55

60

65

16

- (iii) means for receiving and processing said air temperature signal and calculating an air temperature modification value of said base fuel injection value;
- (iv) means for receiving and processing said barometric pressure sensing signal for calculating a barometric pressure modification value of said base fuel injection value;
- (v) means for receiving and processing said engine temperature signal for calculating an engine temperature modification value of said base fuel injection value;
- (vi) means for determining a total fuel injection value representative of the total fuel amount which is to be injected by said fuel injection means during a single two-stroke operating cycle of said piston from said base fuel injection value, said air temperature modification value, said barometric pressure modification value, and said engine temperature modification value;
- (vii) means for determining an injector open duration interval based on said total fuel injection value and a known fuel output rate capacity of said fuel injection means;
- (viii) means for generating a control signal for opening said injection means for said determined injector duration open interval at a predetermined point in time determined from said timing sensing signal;
- (ix) means for receiving and processing said engine speed sensing signal for generating a pump control signal in response thereto for maintaining said pump at an optimum operating speed for providing said predetermined maximum operating pressure in said fuel circulation conduit means at said pump.

\* \* \* \* \*

UNITED STATES PATENT AND TRADEMARK OFFICE  
**CERTIFICATE OF CORRECTION**

PATENT NO. : 4,901,701  
DATED : February 20, 1990  
INVENTOR(S) : Ronald E. Chasteen

It is certified that error appears in the above-identified patent and that said Letters Patent is hereby corrected as shown below:

- Col. 1, Line 65: Delete "Dueto"; insert -- Due to --  
Col. 3, Line 18: Delete "th"; insert -- the --  
Col. 4, Line 1: Delete "s id"; insert -- said --  
Col. 7, Line 66: Delete "8"; insert -- 85 --  
Col. 9, Line 58: Delete "and"; insert -- each --  
Col. 9, Line 61: Delete "a"; insert -- as --  
Col. 12, Line 5: Delete "3"; insert -- 4 --  
Col. 12, Line 18: Delete "RP"; insert -- RPM --  
Col. 12, Line 23: Delete "308"; insert -- 411 --  
Col. 13, Line 22: Delete "308" in both instances; insert -- 411 -- in both instances  
Col. 13, Line 33: Delete "308"; insert -- 411 --  
Col. 15, Line 23: Delete "said"; insert -- a --  
Col. 15, Line 32: Delete "said"; insert -- a --  
Col. 16, Line 9: Delete "said"; insert -- an --  
Col. 16, Line 27: Following "injector" insert -- open --; Following "duration" delete "open"  
Col. 16, Line 33: Delete "said"; insert -- a --  
Col. 16, Line 34: Delete "said"; insert -- a --  
Col. 16, Line 35: Delete "said"; insert -- a --

**Signed and Sealed this**  
**Twenty-first Day of April, 1992**

*Attest:*

HARRY F. MANBECK, JR.

*Attesting Officer*

*Commissioner of Patents and Trademarks*

## **EXHIBIT 4**

- [54] **VEHICLE GEAR SHIFT INDICATOR**  
 [75] Inventors: **Timothy J. Blee; Norman P. Deane,**  
 both of Rugby, Great Britain  
 [73] Assignee: **AE PLC, Warwickshire, England**  
 [21] Appl. No.: **452,083**  
 [22] Filed: **Dec. 22, 1982**  
 [30] **Foreign Application Priority Data**  
 Apr. 22, 1981 [GB] United Kingdom ..... 8112478  
 [51] **Int. Cl.<sup>4</sup>** ..... **B60Q 1/00**  
 [52] **U.S. Cl.** ..... **340/62; 340/52 F**  
 [58] **Field of Search** ..... **340/62, 52 R, 52 F;**  
**364/424.1, 442; 74/866, 335, DIG. 7**

- [56] **References Cited**  
**U.S. PATENT DOCUMENTS**  
 3,420,328 1/1969 Johnson et al. .  
 4,067,232 1/1978 Murray ..... 340/52 R  
 4,171,030 10/1979 Ruhl ..... 340/62  
 4,208,925 6/1980 Miller et al. .  
 4,210,908 7/1980 Sakakibara ..... 340/52 R  
 4,323,895 4/1982 Coste ..... 340/62  
 4,355,296 10/1982 Drone ..... 340/62  
 4,425,620 1/1984 Batcheller et al. .... 340/52 F  
 4,439,158 3/1984 Weber ..... 434/71  
 4,463,427 7/1984 Bonnetain et al. .... 364/442  
 4,494,404 1/1985 Strifler ..... 340/52 R

- FOREIGN PATENT DOCUMENTS**  
 860965 2/1961 United Kingdom .  
 1083940 9/1967 United Kingdom .  
 1386961 3/1975 United Kingdom .  
 1493623 11/1977 United Kingdom .

2068119A 8/1981 United Kingdom .  
*Primary Examiner*—John W. Caldwell, Sr.  
*Assistant Examiner*—Tyrone Queen  
*Attorney, Agent, or Firm*—Leydig, Voit & Mayer

[57] **ABSTRACT**  
 An indicator panel 20 has an array of LED's 25A to 25Q to provide an indication to the driver of a road vehicle, particularly a diesel-powered truck, when he should change to the next highest gear during acceleration from rest or low speed. The LED's are lit progressively as the engine speed increases in each gear and, when lit, emit green light if the engine speed is below the optimum change-up speed for that gear. When the engine speed begins to exceed the optimum change-up speed, the next LED illuminated produces red light to the driver. An audible warning may also be produced. If the driver does not change up in response to such warning, further red LED's will show and a more strident audible warning may be given. The change-up speeds to which the system responds are pre-set so as to be the optimum speeds for increased fuel efficiency. The change-up speed corresponding to the lowest gear is relatively low and increases successively for the successively high gears. The system may be associated with engine speed control or limiting means so as positively to prevent further increase in engine speed if the driver ignores the warning. The system may also produce an indication of the optimum engine speeds at which the driver should change down to the next lower gear during vehicle deceleration.

**14 Claims, 3 Drawing Figures**

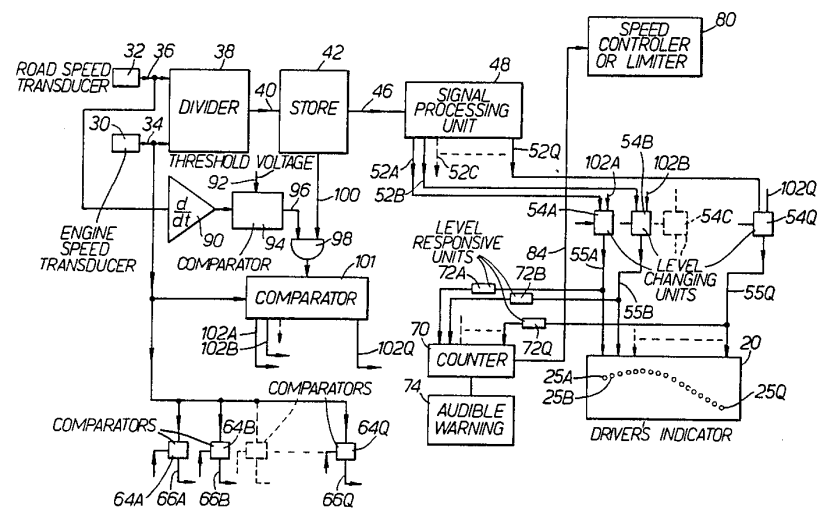

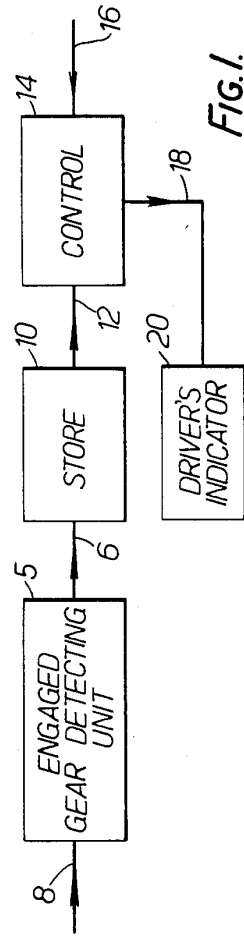

FIG. 1.

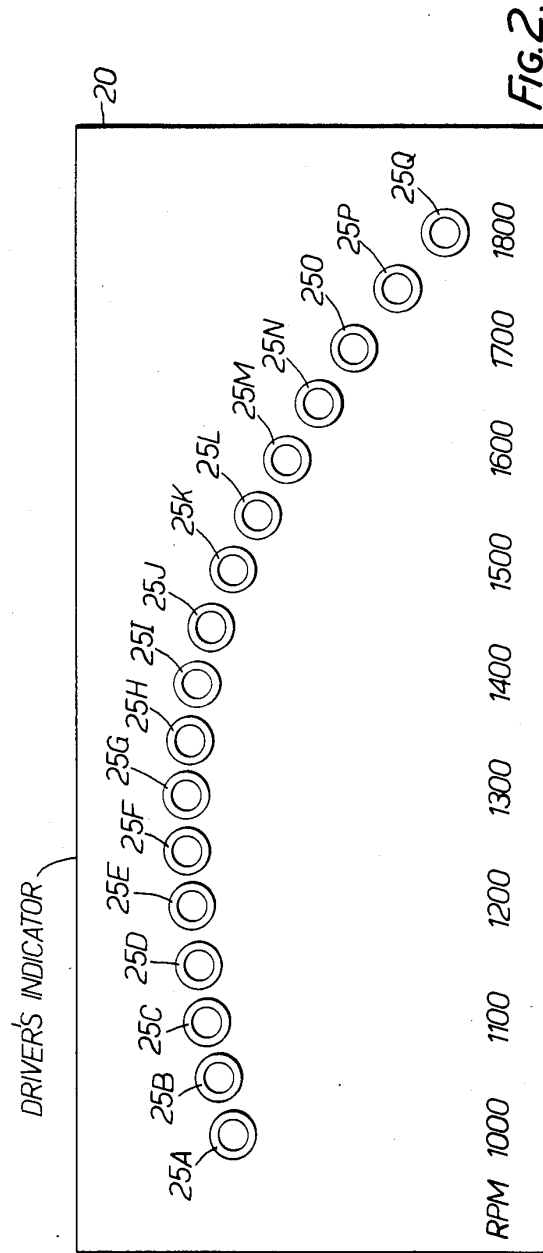

FIG. 2.



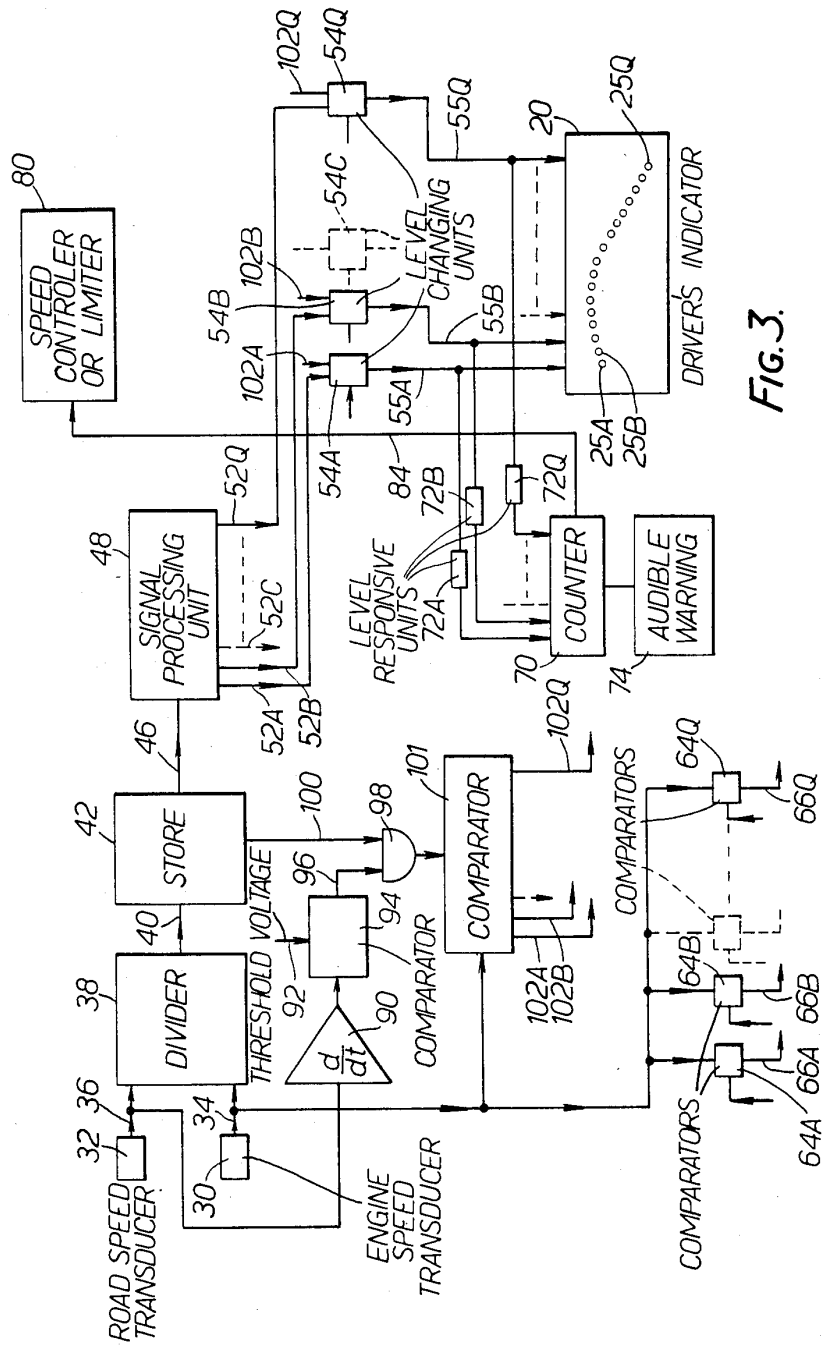

FIG. 3.

## VEHICLE GEAR SHIFT INDICATOR

The invention relates to drive aids for vehicles such as, but not restricted to, road vehicles. Embodiments of the invention to be described provide indications facilitating the efficient control of a road vehicle, such as a diesel-engined truck, by its driver.

According to the invention, there is provided an indicating system for use on a mechanically powered vehicle to indicate to the driver thereof when he should change to a higher gear, comprising means responsive to the particular gear engaged at any time to produce a datum signal having a value representing a datum speed dependent on the identity of the gear, and indicating means responsive to the datum signal and to the actual engine speed and operative when the actual engine speed reaches the datum speed to produce an indication to the driver that he should change to the next higher gear, the values of the datum signals being respectively predetermined so that the respective datum speeds at which the said indications are produced are such that respective gear changes at those speeds promote engine efficiency.

According to the invention, there is also provided a system for indicating to the driver of a road vehicle when he should change to a higher gear, comprising gear-indicating means responsive to the identity of the actual gear engaged at any time to produce a gear-indicating signal, means responsive to the gear-indicating signal to generate an electrical datum signal having a predetermined engine-speed-representing value dependent on the identity of that gear and representing a relatively low engine speed for the lowest gear and successively higher engine speeds for the successively higher gears, an array of light sources for positioning in the vehicle where they may be seen by the driver, and light source control means responsive to each datum signal and to a signal representing actual engine speed to energise the light sources successively as the actual engine speed increases and to modify the indication provided to the driver by the energised light sources when the actual engine speed reaches the speed represented by the datum signal.

According to the invention, there is further provided indicating means for identifying the gear ratio which is currently engaged in a transmission system having a plurality of selectable fixed gear ratios, comprising first transducing means operative to produce a first signal which is proportional to the input speed to the transmission system, second transducing means operative to produce a second signal proportional to the output speed of the transmission system, and signal processing means operative to measure the ratio between the first and second signals to indicate the identity of the engaged gear ratio.

An electrical system embodying the invention and for indicating to the driver of a road vehicle when he should make each gear change for best efficiency, will now be described, by way of example only, with reference to the accompanying diagrammatic drawings in which:

FIG. 1 is a block circuit diagram of one form of the system;

FIG. 2 is a front elevation of an indicator panel showing, diagrammatically, the indication provided to the driver; and

FIG. 3 is a more detailed block circuit diagram of the system.

The system to be described is particularly designed for providing an indication to the driver of a diesel-engined truck when he should make each gear change. Large high-power diesel engines, particularly naturally aspirated types, produce maximum torque at relatively low engine rpm, and it is therefore inefficient and wasteful of fuel for the driver to operate the engine at a speed above the peak of the torque/rpm curve when high road speed of the vehicle is not required or possible. Specifically, when starting the truck from rest, it is wasteful of fuel for the driver to run the engine up to a high speed in the lower gears. When starting the truck from rest, the primary requirement in the lower gears is to take the engine speed up to that at which maximum torque is developed. As the truck speed increases, and as each higher gear is engaged in turn, the engine speed immediately prior to each gear change can be successively increased, assuming that the desired final road speed in the highest gear corresponds to an engine speed above the value at which maximum torque is developed.

In other words, for maximum efficiency, when starting the truck from rest, the driver should make each successive gear change at a successively higher engine speed. The system to be described facilitates this.

FIG. 1 shows the system in broad outline.

As shown, the system comprises an engaged gear detecting unit 5. The purpose of unit 5 is to produce an output signal on a line 6 identifying the particular gear through which the truck engine is driving the road wheels at any particular time (that is, representing the total gear ratio between the truck engine and the road wheels). The unit 5 receives an appropriate input signal on a line 8. For example, line 8 could be controlled by microswitches responsive to the settings of the driver's gear control lever(s). However, other means for producing the signal on line 8 will be described below.

The gear-indicating signal on line 6 is fed as an input to a data store 10. Store 10 stores a number of different datum signals, a different one for each of the truck's gears. The value of each datum signal represents the optimum engine speed at which the driver should change from that gear to the next higher gear, that is, "optimum" primarily in the sense of promoting maximum fuel efficiency. Therefore, as explained, the datum signal corresponding to the lowest gear will represent a relatively low engine speed and the datum signals for the higher gears will represent successively higher engine speed values. Store 10 responds to the particular gear indicated by the signal on line 6 by outputting the appropriate datum signal on a line 12 and this is fed into a signal processing unit 14. Unit 14 also receives a signal representing actual engine speed on a line 16 and produces an output signal on a line 18 which controls a driver's indicating unit 20. Unit 20 is positioned so as to enable the driver to respond readily to its indication. The unit 20 may provide its indication in any suitable form. For example, it may be a visible indication. Instead, it can be an audible indication. As another example, it could be a combination of visible and audible indications.

The signal processing unit 14 controls the indicating unit 20 so that it provides an indication to the driver when the engine speed of the truck in any particular gear reaches the value at which he should change to the next higher gear.

When he has changed to the next higher gear, the signal processing unit 14 receives the new datum signal

on line 12 and is thus able to control the indicating unit 20 so as to provide an indication when the actual engine speed has risen to the (higher) engine speed datum at which he should change up again.

As will be explained in more detail below, the signal processing unit 14 can also be arranged, by means of an appropriate speed control or speed limiting system, to provide a positive limit on the engine speed if the driver should ignore the gear-change-indication provided by the unit 20.

A particular form which the system FIG. 1 can take will now be described in detail with reference to FIGS. 2 and 3.

FIG. 2 shows one form which the driver's indicator 20 (see FIG. 1) may take. It comprises an array of lamps 25A, 25B . . . 25Q. In this example, therefore, there are seventeen lamps and each one corresponds to an engine rpm increment of 50 rpm. The lamps may cover a speed range from 1,000 to 1,800 rpm, say. As the engine speed increases, the lamps are progressively lit, starting with lamp 25A. Therefore, when the engine speed rises to 1,000 rpm, lamp 25A becomes lit. An increase in engine speed to 1,050 rpm causes lamp 25B to be lit, lamp 25A remaining lit; and so on, until, at an engine speed of 1,800 rpm, all the lamps are lit.

In a manner to be explained in more detail, the colours displayed by the illuminated lamps change so as to indicate to the driver when he should make a gear change.

The lamps 25A to 25Q are physically arranged in a curve which approximately matches the shape of the engine torque/engine rpm curve over the speed range (thus showing that peak torque occurs at about 1,300 rpm in this example). They may be light-emitting diodes (LED's).

The system will now be more specifically described with reference to FIG. 3.

As shown in FIG. 3, the system is energised by transducers 30 and 32, transducer 30 providing an electrical output on a line 34 representing engine speed and transducer 32 providing an electrical output on a line 36 representing road speed. The transducers 30 and 32 may be of any suitable type. For example, the engine speed transducer 30 may pick up an electrical signal from the driver's engine rpm indicator, and the road speed transducer may pick up an electrical signal from the vehicle tachograph. However, other arrangements are possible. The electrical outputs on lines 34 and 36 may be in analogue or digital form.

Lines 34 and 36 are fed to a dividing circuit 38 which measures the ratio of their signals. This ratio is solely dependent on the particular gear which is engaged, and the divider 38 compares the measured ratio with each of a number of pre-stored datum values, respectively equal to the ratios corresponding to the gears, and produces an electrical output on a line 40 which indicates which gear is engaged at any particular time.

It will be appreciated that the signal on line 40 could instead be generated by, for example, an electromechanical switch arrangement linked to the gearbox or to the gear selector. However, the arrangement specifically illustrated in FIG. 3 has the advantage of simplicity and absence of moving parts.

However generated, the signal on line 40 is then fed into a store 42. This may be in any suitable form and stores a series of electrical datum signals respectively corresponding to the different gears of the truck. The datum signal stored in store 42 for first gear has the

lowest value, and the values are progressively greater (but not necessarily in linear proportion) for each of the successively higher gears.

Store 42 accesses the appropriate datum signal, that is, the datum signal corresponding to the particular gear engaged (as indicated by the value of the signal on line 40), and outputs this datum signal on a line 46. This signal is passed to a processing unit 48.

The processing unit 48 has a bank of output lines 52A, 52B . . . 52Q (not all of which are shown) and these are respectively connected to level changing units 54A, 54B . . . 54Q (not all of which are shown), and the actual connections are mostly omitted to avoid unduly complicating the diagram.

The outputs of the level changing units 54A, 54B . . . 54Q are connected by respective lines 55A, 55B . . . 55Q to control respective ones of the lamps 25A, 25B . . . 25Q in the driver's display 20.

The processing unit 48 energises the lines 52A, 52B . . . 52Q according to the value of the signal on line 46, each line 52A, 52B . . . 52Q having either a HIGH value or a LOW value. When the signal level on line 46 is low, only the earliest one or ones in the sequence of lines 52A to 52Q are held at the LOW level and all the remainder are HIGH; for example, with the signal on line 46 at its lowest level (corresponding to first gear), only lines 52A and 52B, say, would be at the LOW level, with all the remainder at the HIGH level. For a signal level on line 46 corresponding to second gear, more of the lines in the series 52A to 52Q would be at the LOW level, such as lines 52A, 52B, 52C and 52D for example, with all the remainder at the HIGH level; and so on for all the other possible values of the signal on line 46. Thus, for a signal level on line 46 corresponding to the highest gear (the truck may have eight or nine gears for example), all the lines 52A to 52Q could be at the LOW level.

The engine speed-dependent signal on line 34 is also connected to feed a bank of comparators 64A, 64B . . . 64Q (only some of which are shown). Each comparator has a second input lines which carries a respective threshold signal (the sources of these thresholds not being shown in the Figure). The comparators 64A to 64Q are connected through the level changing units 54A to 54Q to the LED's by means of respective output lines 66A to 66Q.

When the engine speed is low (below 1,000 rpm in this example), none of the lines 66A to 66Q is energised. As the engine speed increases to 1,000 rpm and beyond, the lines 66A to 66Q successively become energised. The threshold signals applied to the comparators 64A to 64Q are set so that line 66A becomes energised when the engine speed is 1,000 rpm, line 66B becomes energised when the engine speed reaches 1,050 rpm, line 66C becomes energised when the engine speed reaches 1,100 rpm and so on, until line 66Q becomes energised when the engine speed reaches 1,800 rpm (all the earlier-energised lines remaining energised).

As each line 66A to 66Q becomes energised, it causes the corresponding LED 25A to 25Q to become illuminated. Assuming that the corresponding one of the lines 52A to 52Q is at a LOW level, the illuminated LED will emit green light. However, if the corresponding line 52A to 52Q is at a HIGH level, then the corresponding level changing unit 54A to 54Q will cause the illuminated LED to emit red light instead.

The operation of the system as so far described will now be considered.

If the truck is running at a steady relatively high speed in the highest gear, so that its engine speed is above 1,800 rpm, all the LED's 25A to 25Q will be green. If the truck speed now decreases, causing or as a result of a corresponding fall in engine speed, then the LED's will be extinguished one by one as the engine speed falls below 1,800 rpm. Assuming that the truck speed is falling at greater than the threshold rate represented by the signal on line 92, unit 94 will open gate 98 and the comparator 101 will be fed with the datum signal on line 100 representing the minimum appropriate speed for the current gear (top gear); this might be an engine speed of 1,400 rpm for example. Therefore, when comparator 101 determines that the actual engine speed has fallen to 1,400 rpm, it energises the lines 102A to 102I. The resultant signals applied to level changing units 54A to 54I cause the corresponding LED's 25A to 25I to change from green to red. This therefore provides an indication to the driver that he should change to a lower gear.

If the driver allows the engine speed to fall further without making a gear change, then the falling signal on line 34 will cause the comparators 64A to 64I (in this example) to extinguish the LED's one by one.

During such deceleration, the audible warning unit 74 may be disabled.

It will be appreciated that the detailed circuitry shown in FIG. 3 is merely exemplary of the many different possible forms which it can take, and many modifications are possible. For example, but without limitation, the interlinking of the gear change indication system with the speed control system 80 may be omitted, and/or the arrangement of the system so as to provide an indication to the driver when he should change to a lower gear may be omitted.

Although the systems described have been described in relation to trucks and more particularly to trucks powered by diesel engines, they may be applied (with appropriate modification if necessary) to vehicles other than trucks and to vehicles powered by other types of engine, and "vehicle" is not restricted to road vehicles; as examples, it may include rail vehicles and boats.

We claim:

1. An indicating system for use on a mechanically propelled vehicle having a driver-operated engine-driving wheels transmission system using a plurality of separate gears normally operable in an ascending or descending sequence and to indicate to the driver thereof when he should change from the particular one of the gears which is engaged at any time to the next gear in one of the sequences comprising

means responsive to the particular gear engaged to produce an electrical datum signal having a value representing a datum speed dependent on the identity of that gear,

indicating means comprising means operative in response to predetermined control signals to produce respective ones of a series of indications to the driver indicating with successively greater urgency that he should change to the next gear in the said sequence,

means responsive to the actual speed of the engine or of the vehicle to produce an electrical signal representing that speed,

control means responsive to the datum signal and to the electrical signal representing the actual speed and operative when the actual speed reaches the

datum speed to produce a first one of the said control signals,

means feeding the first control signal to the indicating means to cause the indicating means to produce the first said indication in the said series,

means responsive to the datum signal and to the electrical signal representing the actual speed and connected to sense whether the driver changes to the said next gear in the sequence in response to the said first indication in the said series and, if he does not, to produce successive further said control signals as the actual speed exceeds the datum speed by a respective predetermined amount or amounts, and

means connected to feed the said further control signals to the indicating means to cause the indicating means to produce in succession the other indications in the said series,

the values of the datum signals being respectively predetermined so that the respective datum signals are such that respective gear changes at those speeds promote engine efficiency, the datum signals having values which are pre-calculated and are independent of the actual operation of the vehicle at any time.

2. A system according to claim 1, in which the datum speed for the lowest gear represents a relatively low engine speed and the datum speeds for the higher gears represent successively higher engine speeds.

3. A system according to claim 1, in which each said indication is a visible indication.

4. A system according to claim 1, in which each said indication is an audible indication.

5. A system according to claim 1, in combination with a speed control arrangement connected to the vehicle engine and comprising means responsive to an engine speed control signal to positively prevent further increase in engine speed, the system including means responsive to the engine speed exceeding the respective said datum speed for the said particular one of the gears which is engaged at any time to generate a said engine speed control signal, and means feeding the engine speed control signal to the speed control arrangement.

6. A system for indicating to the driver of a road vehicle having a multiple-gear engine-driving wheels transmission system when he should change from a particular one of the gears which is engaged at any time to a higher gear, comprising

gear-indicating means responsive to the identity of the said particular one of the gears to produce an electrical gear-indicating signal indicating the identity of that particular gear,

means connected to receive and to be responsive to the gear-indicating signal to generate a respective one of a plurality of electrical datum signals having respective predetermined engine-speed-representing values dependent on the identity of the said particular one of the gears and representing a relatively low engine speed for the lowest gear of the transmission system and successively higher engine speeds for the successively higher gears thereof, an array of light sources for positioning in the vehicle where they may be seen by the driver, and

light source control means connected to control the array of light sources and connected to receive and to be responsive to each datum signal and to an electrical signal representing actual engine speed whereby to energise the light sources successively

5

As the truck moves off from rest in first gear, the engine speed will be below 1,000 rpm and none of the lines 66A to 66Q will be energised. Therefore, none of the LED's 25A to 25Q will be illuminated. The divider 18 will determine from the ratio of its inputs that first gear is engaged and store 42 will therefore produce the appropriate datum signal output. As explained, this will be at such a value that unit 48 will hold most of its output lines 52A to 52Q at the HIGH level with only lines 52A and 52B (in this example) being at the LOW level.

As the engine speed increases to 1,000 rpm (with the truck still in first gear), line 66A becomes energised and LED 25A becomes lit. Because the corresponding level changing unit 54A is receiving only a LOW level, line 66A is energised at a low level and LED 25A emits green light.

As the engine speed continues to increase, LED 25B will become illuminated and emit green light (because it is assumed in this example that line 52B is at a LOW level).

However, line 52C and all remaining lines up to 52Q are at a HIGH level. Therefore, when the engine speed reaches 1,100 rpm in this example, LED 25C becomes illuminated and emits red light, in contrast to LED's 25A and 25B which are green.

This provides an indication to the driver that he has reached an engine speed value which, for the particular gear engaged at the present time (first gear), is such that he should change to the next higher gear.

If he does not change gear, the engine speed will continue to rise and LED 25D will be illuminated and emit red light, and similarly for LED 25E assuming that he still does not make a gear change.

However, if he does make a gear change, this will be detected by the divider 38 and the store 42 will change the value of the signal on line 46 to a higher value. This causes the processing unit 48 to alter the energisation of the lines 52A to 52Q so that, for example, lines 52A, 52B, 52C and 52D are now all at a LOW level while the remainder (52E to 52Q) are at a HIGH level.

Therefore, LED 25C, which was previously emitting red light, will now change to green, assuming the engine speed is still at 1,100 rpm (clearly, the engine speed may fall slightly during the actual gear change but will then start to rise again in the higher gear).

When the engine speed has reached the appropriate limit for second gear, 1,250 in this example, LED 25E becomes illuminated and emits red light. This indicates to the driver that he must make the next gear change.

This process continues for each succeeding gear, so that the display 20 indicates to the driver the appropriate engine speed at which he should make each gear change.

The datum signals in store 42 are pre-selected so that the indicated gear-change speeds increase successively and according to an appropriate curve so as to obtain maximum fuel efficiency from the engine.

As shown, the lines 55A to 55Q are also connected to a counting unit 70 through level-responsive units 72A, 72B . . . 72Q only some of which are shown. The level-responsive units are set so that the counter is only affected by the signals on the lines 52A to 52Q when they have the higher levels corresponding to emission of red light from the associated LED. The counter 70 counts the number of lines 55A to 55Q carrying red-producing levels and operates an audible warning unit 74 accordingly. More specifically, when counter 70 detects one

6

line 55A to 55Q carrying a red-indicating level, it causes the audible warning unit 74 to emit an intermittent low-frequency sound warning to the driver, advising him that the gear-change limit has been reached. If the driver does not make a gear change, then, as explained, the next line of the lines 55A to 55Q will change to a red-indicating level. This will be detected by the counter 70 which causes the warning unit 74 to increase the frequency of its sound output. A still further increase in engine speed without gear change, producing a third red-indicating level input to counter 70, causes the unit 74 to emit a continuous sound output.

The truck may also be fitted with a road speed control system indicated diagrammatically by the block 80. Such a system may take any suitable form, such as, for example, described in our British Pat. Nos. 1386961 and 1493623. Normally such a system 80 operates only when the truck is in the highest gear, so as to limit the truck's road speed to a particular upper speed value (or to control it at that value) and this operation is independent of the gear-change indicating system as so far described. However, the gear-change indicating system described may be linked to the speed control system 80 by means of a line 84 from the counter 70.

Counter 70 energises line 84 when it determines that at least three of the lines 55A to 55Q are carrying red-indicating levels. When the speed control 80 receives the signal on line 84, it operates (irrespective of the particular gear engaged at that time) to prevent further increase in engine speed. Therefore, if the driver persists in ignoring the gear-change indication given by the display unit 20, further increase in engine speed will be positively prevented.

As so far described, the operation of the gear-change indicating system is that which occurs when the truck is accelerating. The operation is different if the vehicle is decelerating, as will now be described.

Deceleration of the truck is sensed by a differentiating unit 90 responsive to the road speed signal on line 36. If the vehicle is decelerating at at least a predetermined rate represented by a threshold on a line 92, a comparator 94 energises a line 96 to open a gate 98.

Besides producing the datum signal on line 46, store 42 produces a second datum signal on a line 100. In contrast to the datum signals on line 46, the datum signals on line 100 represent the minimum appropriate engine speed corresponding to each gear. Line 100 is connected through gate 98 to a comparator 101 which also receives the engine speed indicating signal from line 34. Gate 98 only passes the signal on line 96 to comparator 101 when the truck is decelerating at at least the speed set by the threshold on line 92. Comparator 101 has output lines 102A to 102K and these are connected to third inputs of the level changing units 54A to 54K, the actual connections being omitted. When comparator 101 determines that the actual engine speed has fallen to the level represented by the datum signal on line 100, it energises the corresponding output line 102A to 102K and also all the other ones of its output lines which represent lower speed values. Thus, for example, if the signal on line 100 represents a datum speed of 1,400 rpm, comparator 101 will energise its output line 102I (which is connected to the level changing unit 54I controlling the LED 25I representing 1,400 rpm); in addition, it will energise all the lines 102A to 102H.

The operation of this part of the system will now be considered in more detail.

9

as the actual engine speed increases, the light source means including modifying means adapted to modify the indication provided to the driver by the energised light sources and means responsive to each datum signal and to the electrical signal representing actual engine speed to sense the extent by which the actual engine speed exceeds the speed represented by the datum signal and operative to actuate the modifying means to cause the array of light sources to produce a series of indications to the driver indicating with successively greater urgency as the said extent increases that he should change to the said next higher gear.

7. A system according to claim 6, in which the light source control means modifies the indication provided by the energised light source or sources by changing the colour of the light emitted thereby.

8. A system according to claim 6, including an audible indicating unit responsive to each datum signal and to the electrical signal representing actual engine speed to produce an audible indication when the actual engine speed exceeds the speed represented by the respective datum signal.

10

9. A system according to claim 6, in which the light sources are light-emitting diodes.

10. A system according to claim 6, in which the array of light sources is physically arranged in a manner corresponding at least approximately to the shape of the torque versus engine speed characteristic of the engine.

11. A system according to claim 1, applied to a truck or similar heavy road vehicle powered by a diesel engine.

12. A system according to claim 1, in which the said actual speed is the engine speed.

13. A system according to claim 6 in which the gear-indicating means comprises

first transducing means operative to produce a first signal which is proportional to the input speed to the transmission system,

second transducing means operative to produce a second signal which is proportional to the output speed of the transmission system, and

signal processing means operative to measure the ratio between the first and second signals to indicate the identity of the engaged gear ratio.

14. A system according to claim 13, in which the first and second signals are electrical signals.

\* \* \* \* \*

30

35

40

45

50

55

60

65

## **EXHIBIT 5**



US005708584A

**United States Patent** [19]  
Doi et al.

[11] **Patent Number:** 5,708,584  
[45] **Date of Patent:** Jan. 13, 1998

[54] **VEHICLE RUNNING MODE DETECTING SYSTEM**

FOREIGN PATENT DOCUMENTS

61-146644 7/1996 Japan .

[75] Inventors: **Ayumu Doi; Yasunori Yamamoto; Hideki Nishitake; Tomohiko Adachi,** all of Hiroshima-ken, Japan

*Primary Examiner*—Gary Chin  
*Attorney, Agent, or Firm*—Sixbey, Friedman, Leedom & Ferguson, P.C.; Gerald J. Ferguson, Jr.

[73] Assignee: **Mazda Motor Corporation,** Hiroshima, Japan

[57] **ABSTRACT**

[21] Appl. No.: 525,218

In a vehicle running mode detecting system, a relative speed of a vehicle, equipped with the vehicle running mode detecting system, to a forward object is calculated on the basis of a time elapsed from a reference time based on which the time elapsed is measured and a change in the distance between the vehicle and the forward object during the time elapsed. Whether the vehicle is running in a constant distance mode where the distance between the vehicle and the forward object is kept substantially constant or in a varying distance mode where the vehicle is accelerating or decelerating relative to the forward object and the distance between the vehicle and the forward object is varying is determined on the basis of the change in the distance between the vehicle and the forward object. The reference time is updated less frequently when the vehicle is running in the constant distance mode than when the vehicle is running in the varying distance mode.

[22] Filed: Sep. 8, 1995

[30] **Foreign Application Priority Data**

Sep. 14, 1994 [JP] Japan ..... 6-220294

[51] **Int. Cl.<sup>6</sup>** ..... **B60T 8/32**

[52] **U.S. Cl.** ..... **364/426.044; 364/461; 180/169; 180/170; 340/903**

[58] **Field of Search** ..... **364/426.041, 426.044, 364/460, 461, 565; 180/167-170, 176-179; 123/350, 352; 342/454, 455; 340/903, 904**

[56] **References Cited**

U.S. PATENT DOCUMENTS

4,621,705 11/1986 Etoh ..... 180/169  
5,053,979 10/1991 Etoh ..... 364/426.044  
5,396,426 3/1995 Hibino et al. .... 364/426.044  
5,420,792 5/1995 Butsuen et al. .... 364/461

9 Claims, 5 Drawing Sheets

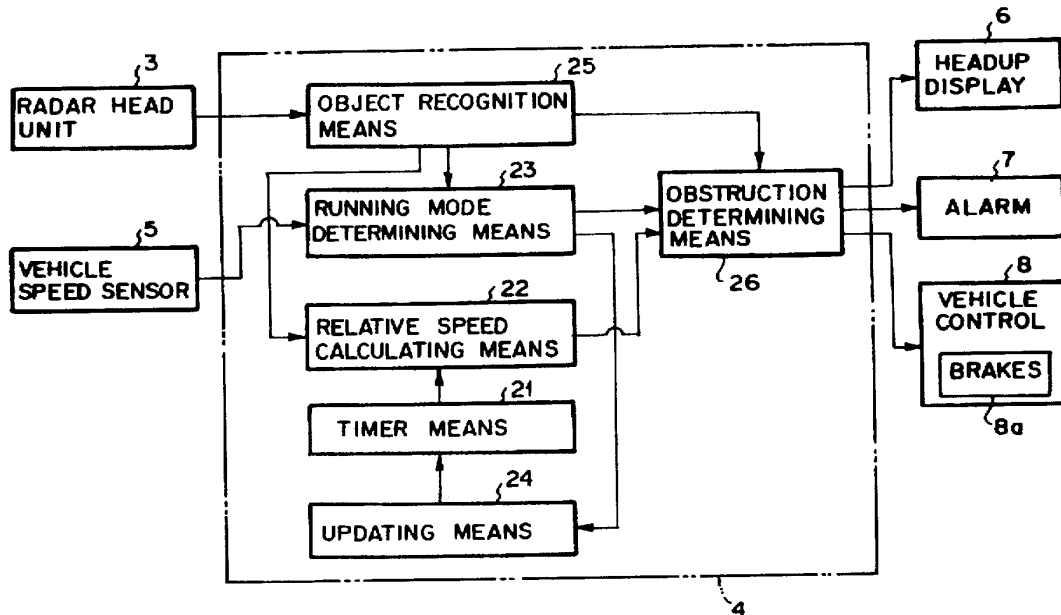



FIG. 1

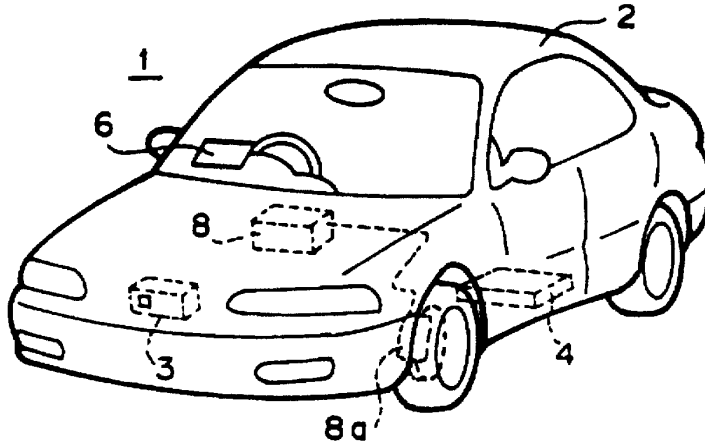
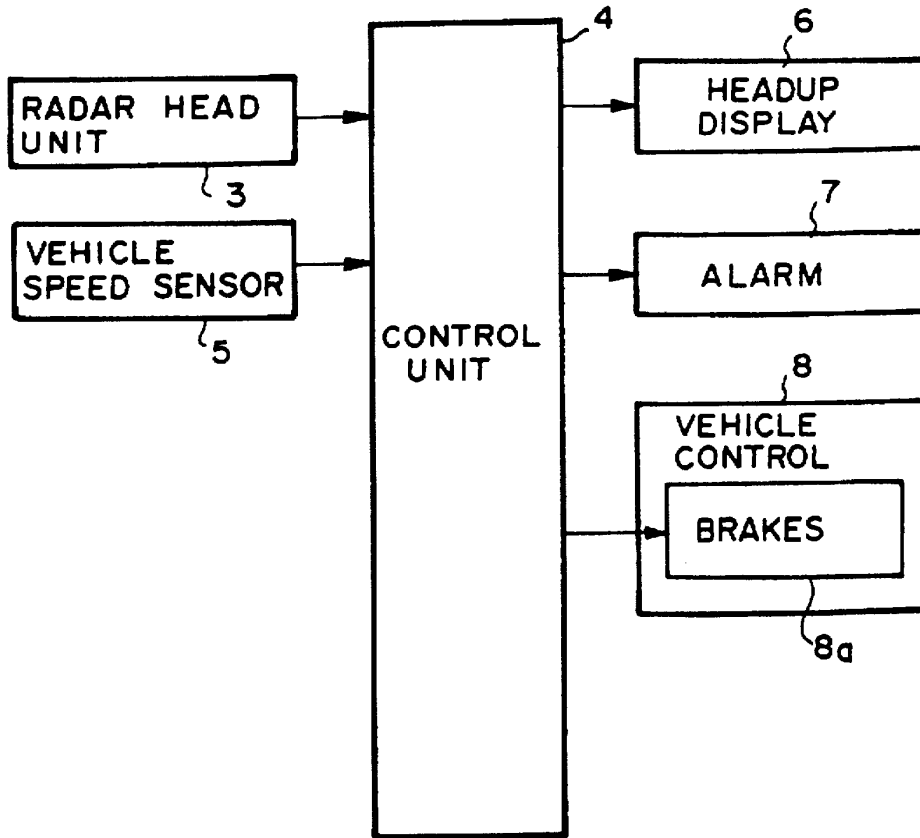

FIG. 2



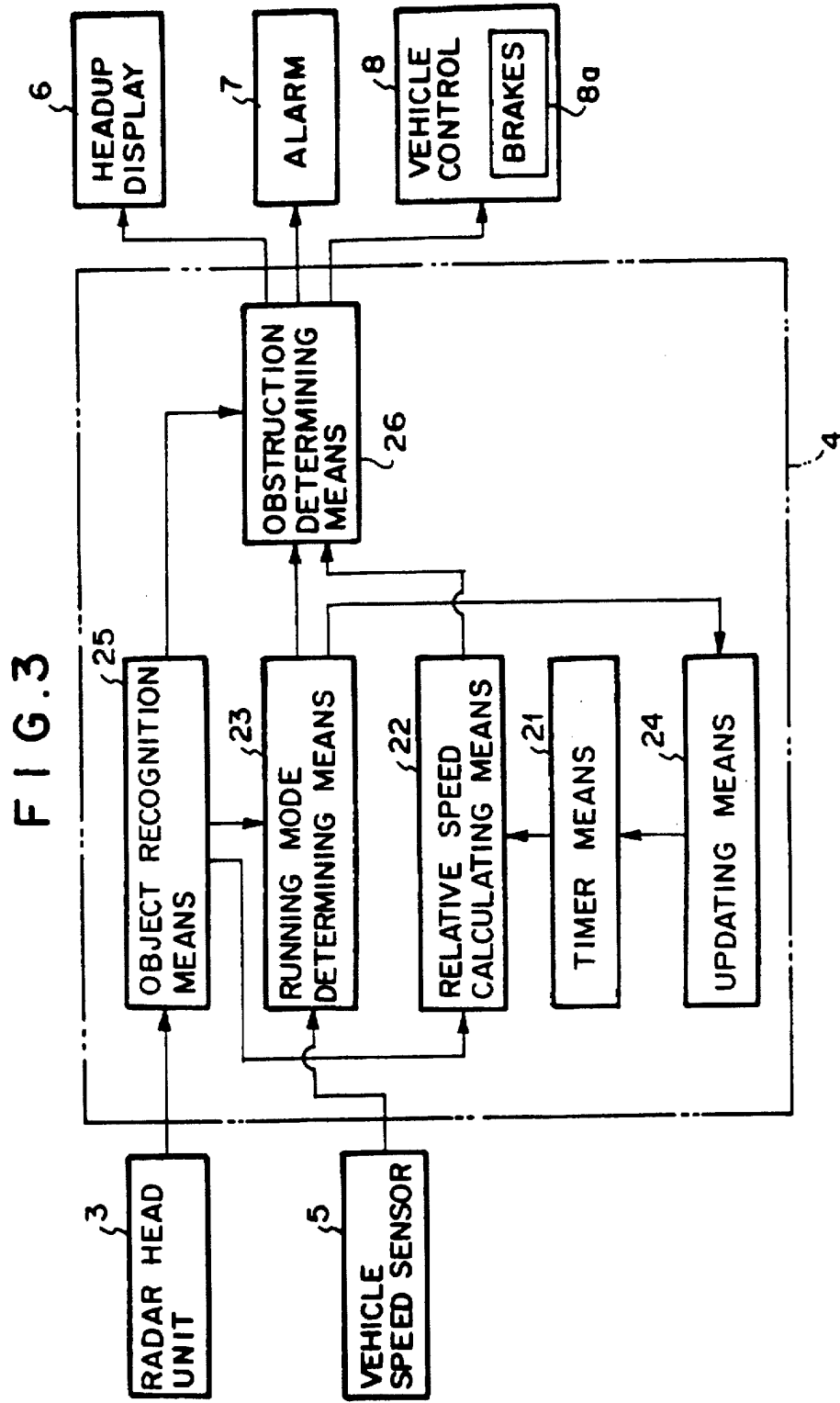

FIG. 4

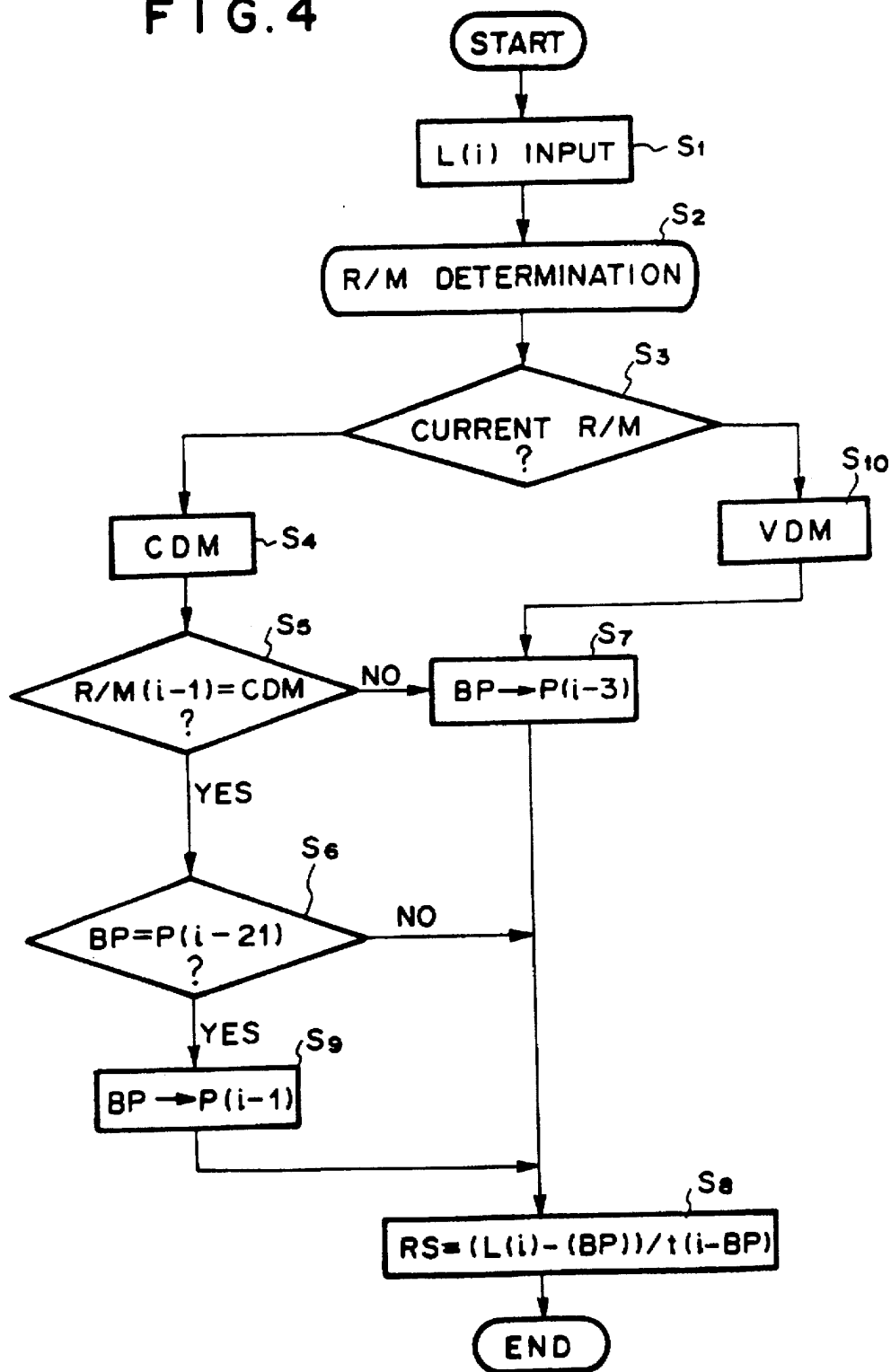

FIG. 5

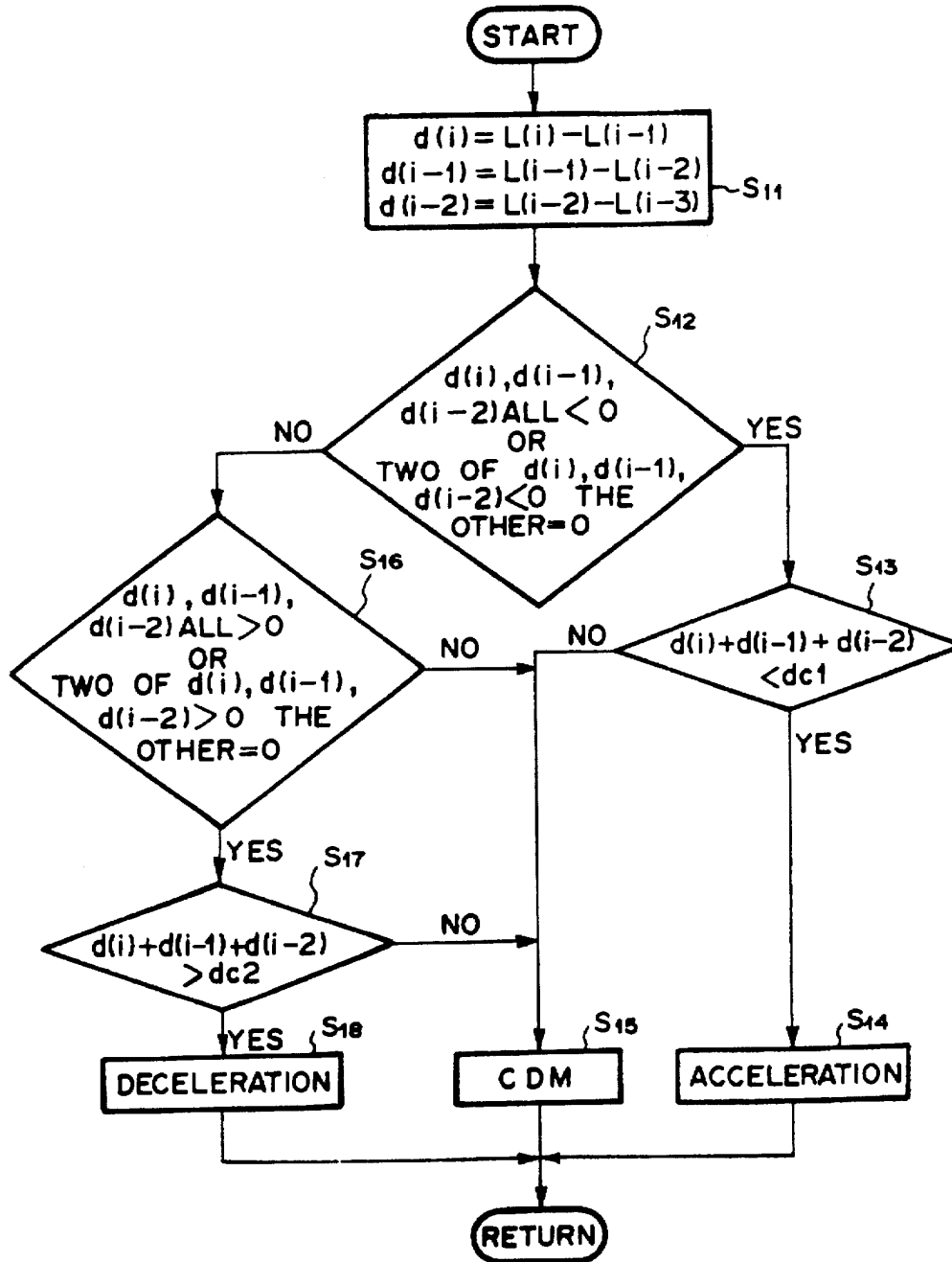
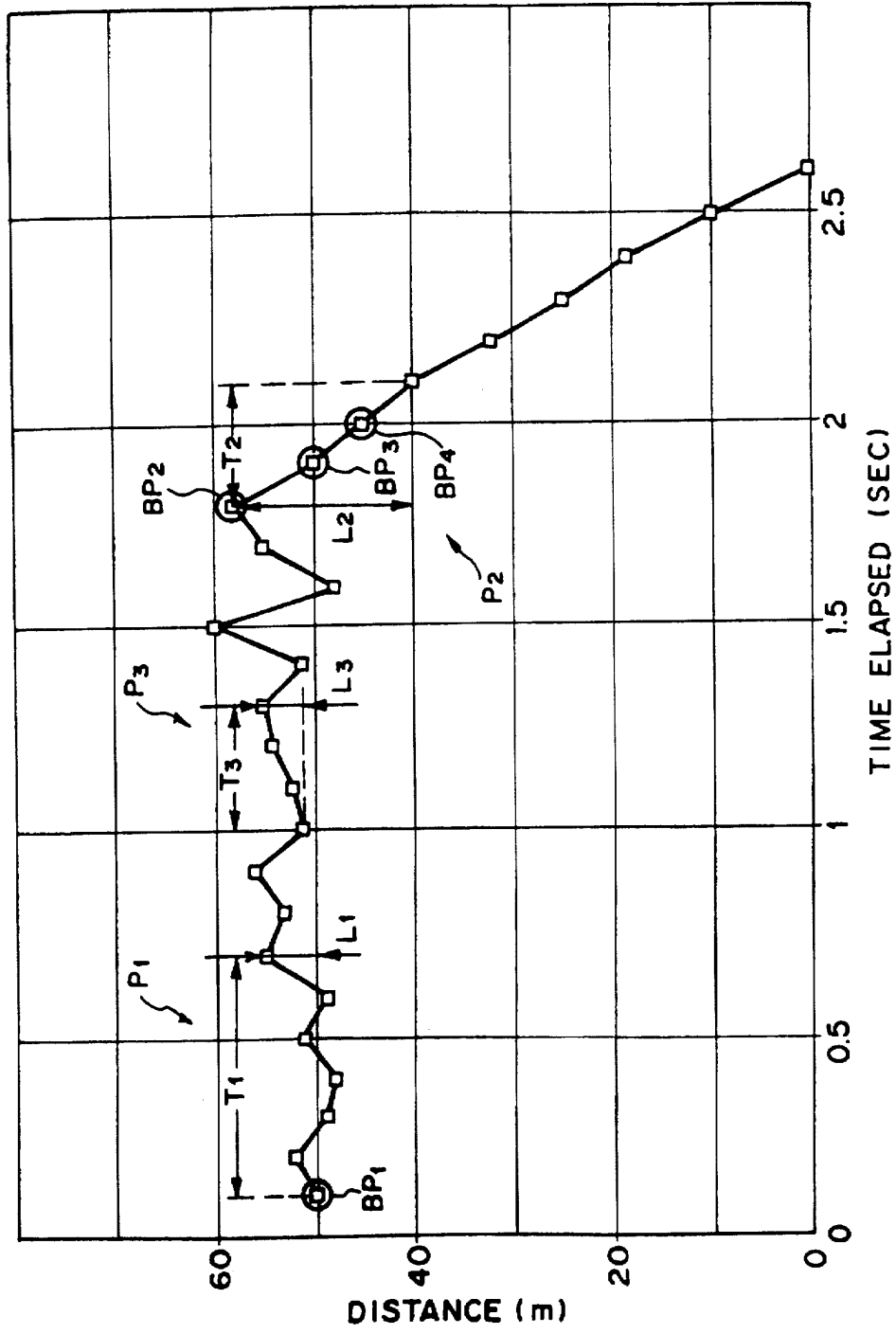

FIG. 6



1

## VEHICLE RUNNING MODE DETECTING SYSTEM

### BACKGROUND OF THE INVENTION

#### 1. Field of the Invention

This invention relates a vehicle running mode detecting system which is provided with a relative speed calculating means which calculates the relative speed of a vehicle to a forward object being ahead of the vehicle in the way on the basis of a time elapsed from a reference time and a change in the distance between the vehicle and the forward object during the time elapsed.

#### 2. Description of the Related Art

As disclosed, for instance, in Japanese Unexamined Patent Publication No. 61 (1986)-146644, there has been known a vehicle running mode detecting system in which the relative speed of a vehicle to the forward vehicle running ahead thereof is calculated on the basis of changes in the distance between the vehicles during different time intervals, thereby eliminating necessity of additional relative speed calculating means.

However in the system, since the relative speed is uniformly calculated independently from the running mode of the vehicle, i.e., whether the vehicle is running substantially at a constant distance from the forward vehicle or at a decreasing or increasing distance from the forward vehicle, efficiency of calculating the relative speed is low.

### SUMMARY OF THE INVENTION

In view of the foregoing observations and description, the primary object of the present invention is to provide a vehicle running mode detecting system which can detect the relative speed of a vehicle to a forward object (e.g., a forward vehicle) at a high efficiency.

In accordance with one aspect of the present invention, there is provided a vehicle running mode detecting system comprising a relative speed calculating means which calculates the relative speed of a vehicle, equipped with the vehicle running mode detecting system, to a forward object on the basis of a time elapsed from a reference time based on which the time elapsed is measured and a change in the distance between the vehicle and the forward object during the time elapsed, a running mode determining means which determines whether the vehicle is running in a constant distance mode where the distance between the vehicle and the forward object is kept substantially constant or in a varying distance mode where the vehicle is accelerating or decelerating relative to the forward object and the distance between the vehicle and the forward object is varying on the basis of the change in the distance between the vehicle and the forward object, and a reference time updating means which receives an output of the running mode determining means and updates the reference time less frequently when the running mode determining means determines that the vehicle is running in the constant distance mode than when the running mode determining means determines that the vehicle is running in the varying distance mode.

In an embodiment, the reference time is updated at predetermined intervals which are set longer when the running mode determining means determines that the vehicle is running in the constant distance mode than when the running mode determining means determines that the vehicle is running in the varying distance mode.

In another embodiment, the running mode determining means determines that the vehicle is running in the constant

2

distance mode unless the distance to the forward object decreases or increases continuously.

In still another embodiment, the running mode determining means determines that the vehicle is running in the constant distance mode when the change in the distance to the forward object is small even if the distance to the forward object decreases or increases continuously.

In still another embodiment, the reference time updating means updates the reference time when the running mode determining means keeps determining that the vehicle is running in the constant distance mode for a time not shorter than a predetermined time.

In accordance with another aspect of the present invention, there is provided a vehicle running mode detecting system comprising a relative speed calculating means which calculates the relative speed of a vehicle, equipped with the vehicle running mode detecting system, to a forward object on the basis of a time elapsed from a reference time based on which the time elapsed is measured and a change in the distance between the vehicle and the forward object during the time elapsed, a running mode determining means which determines that the vehicle is running in a varying distance mode where the vehicle is accelerating or decelerating relative to the forward object and the distance between the vehicle and the forward object is varying on the basis of the change in the distance between the vehicle and the forward object, and a reference time updating means which receives an output of the running mode determining means and updates the reference time more frequently as the degree of acceleration or deceleration of the vehicle increases.

### BRIEF DESCRIPTION OF THE DRAWINGS

FIG. 1 is a perspective view of a vehicle equipped with a running control system employing a vehicle running mode detecting system in accordance with an embodiment of the present invention.

FIG. 2 is a schematic block diagram of the running control system.

FIG. 3 is a block diagram of the control unit.

FIG. 4 is a flow chart for illustrating the basic control of the control unit.

FIG. 5 is a flow chart for illustrating the manner of determining the running mode of the vehicle, and

FIG. 6 is a view for illustrating the manner of determining the running mode of the vehicle.

### DESCRIPTION OF THE PREFERRED EMBODIMENT

In FIG. 1, a vehicle 1 is equipped with a running control system comprising a radar head unit 3 mounted in the front of the vehicle body 2, a control unit 4, a vehicle speed sensor 5, a headup display 6, an alarm 7 (FIG. 2) and a vehicle control device 8.

The radar head unit 3 emits a pulse laser beam (as a radar wave) forward of the vehicle 1 from a source and receives reflected light beam reflected by a forward object in the way such as a vehicle, thereby measuring the distance from the vehicle 1 to the forward object. The radar head unit 3 is of a scan type which causes a pulse laser beam, which is small in width and like a sector in a vertical cross-section, to scan horizontally through a relatively wide angle.

As shown in FIG. 2, signals from the radar head unit 3 and the vehicle speed sensor 5 which detects the running speed

3

of the vehicle 1 are input into the control unit 4 and the running mode of the vehicle 1 is determined by the control unit 4 and shown by the headup display 6. When it is determined that the forward object is an obstruction for the vehicle 1 to clear, the alarm 7 operates and the vehicle control device 8 automatically causes brakes 8a of the vehicle 1 to operate to decelerate the vehicle 1.

As shown in FIG. 3, the control unit 4 comprises an object recognition means 25 which receives a signal from the radar head unit 3 and recognizes a forward object such as a forward vehicle in the way of the vehicle 1, a relative speed calculating means 22 which receives signals from the object recognition means 25 and a timer means 21 and calculates the relative speed of the vehicle 1 to the forward object on the basis of a time elapsed from a reference time based on which the time elapsed is measured and a change in the distance between the vehicle 1 and the forward object during the time elapsed, a running mode determining means 23 which receives outputs of the object recognition means 25 and the vehicle speed sensor 5 and determines whether the vehicle 1 is running in a constant distance mode where the distance between the vehicle 1 and the forward object is kept substantially constant or in a varying distance mode where the vehicle 1 is accelerating or decelerating relative to the forward object and the distance between the vehicle 1 and the forward object is varying, and a reference time updating means 24 which receives an output of the running mode determining means 23 and sets the reference time updating frequency by the relative speed calculating means 22 lower when the running mode determining means 23 determines that the vehicle 1 is running in the constant distance mode than when the running mode determining means 23 determines that the vehicle 1 is running in the varying distance mode.

The control unit 4 further comprises an obstruction determining means 26 which receives outputs of the object recognition means 25 and the relative speed calculating means 22 and determines whether the forward object is an obstruction for the vehicle 1 to clear.

The running mode determining means 23 determines that the vehicle is running in the constant distance mode unless the distance to the forward object decreases or increases continuously and also determines that the vehicle is running in the constant distance mode when the change in the distance to the forward object is small even if the distance to the forward object decreases or increases continuously. Further the running mode determining means 23 determines whether the vehicle 1 is accelerating, decelerating or running at a constant speed on the basis of the signal from the vehicle speed sensor 5.

The reference time updating means 24 updates the reference time when the running mode determining means 23 keeps determining that the vehicle 1 is running in the constant distance mode for a time not shorter than a predetermined time in order to prevent deterioration in accuracy of detecting the relative speed.

The control by the control unit 4 will be described hereinbelow with reference to FIG. 4 assuming that a forward vehicle is recognized as the forward object. In this particular example, the object recognition means 25 detects the vehicle-to-vehicle distance (the distance between the forward vehicle and the vehicle 1) at regular intervals on the basis of the signal from the radar head unit 3. In the following description,  $L(i)$  denotes the current vehicle-to-vehicle distance.

In FIG. 4, the vehicle-to-vehicle distance  $L(i)$  is input. (step S1) More particularly, the last 19 vehicle-to-vehicle

4

distances  $L(i-19)$  to  $L(i-1)$  are stored by the object recognition means 25.

Then the running mode (R/M) of the vehicle 1 is determined on the basis of the change in the vehicle-to-vehicle distance calculated on the basis of the output of the object recognition means 25 and the running speed of the vehicle 1 detected by the vehicle speed sensor 5. (step S2) Then the running mode determining means determines whether the current running mode is the constant distance mode (CDM) or the varying distance mode (VDM). (step S3)

When it is determined that the current running mode is constant distance mode, it is registered in the obstruction determining means 26. (step S4) Thereafter it is determined whether the preceding running mode (the running mode one point before) was the constant distance mode. (step S5) When it is determined that the preceding running mode was also the constant distance mode, it is determined that the current base point (or the reference time) from which the time elapsed is measured is the point which is 21 point before. When it is determined in step S5 that the preceding running mode was not the constant distance mode, that is, when the preceding running mode was the varying distance mode, the base point is updated to the point 3 point before (step S7) and then the relative speed is calculated according to the following formula (step S8).

$$R_s = \{L(i) - L(BP)\} / t(i-BP)$$

wherein  $R_s$  represents the relative speed,  $L(i)$  represents the vehicle-to-vehicle distance at the current point,  $L(BP)$  represents the vehicle-to-vehicle distance at the base point BP and  $t(i-BP)$  represents the time difference (the time elapsed) between the current point and the base point BP.

For example, assuming that the time elapsed from the base point BP1 is  $T1$  and the change in the vehicle-to-vehicle distance during the time  $T1$  is  $L1$  in the part indicated at P1 in FIG. 6, the relative speed  $R_s$  is  $L1/T1$ .

When it is determined in step S6 that the current base point is the point which is 21 point before, the base point BP is updated to the point 1 point before (step S9) and then step S8 is executed. That is, when the running mode is the constant distance mode at successive tow points including the current point, the base point is not updated until the running mode keeps being the constant distance mode. In this particular embodiment, the base point is updated every 21 points when the running mode keeps being the constant distance mode.

When it is determined in step S3 that the current running mode is the varying distance mode, the step 7 is executed and the base point BP is updated to the point 3 point before after that the current running mode is the varying distance mode is registered in the obstruction determining means 26 in step S10. For example, when the vehicle-to-vehicle distance is decreasing, i.e., when the vehicle 1 is accelerating relative to the forward vehicle as in the part indicated at P2 in FIG. 6, the base point BP is changed from BP1 to BP2 and the relative speed  $R_s$  is  $L2/T2$  assuming that the time elapsed from the base point BP2 is  $T2$  and the change in the vehicle-to-vehicle distance during the time  $T2$  is  $L2$ . Thus when the varying distance mode continues, the base point BP is constantly updated to BP3, BP4 and so on so that the relative speed  $R_s$  can be calculated following abrupt change in the same.

In step S3, the running mode is determined in the manner shown in FIG. 5. That is, the changes in the vehicle-to-vehicle distance between each of last three points and the preceding point  $d(i)$ ,  $d(i-1)$  and  $d(i-2)$  are calculated as follows. (step S11)

5

$$d(i)=L(i)-L(i-1)$$

$$d(i-1)=L(i-1)-L(i-2)$$

$$d(i-2)=L(i-2)-L(i-3)$$

Then it is determined whether or not the changes  $d(i)$ ,  $d(i-1)$  and  $d(i-2)$  are all negative or two of them are negative with the other being 0. (step S12) When it is determined that the changes  $d(i)$ ,  $d(i-1)$  and  $d(i-2)$  are all negative or two of them are negative with the other being 0, it is determined whether the sum of the changes  $d(i)$ ,  $d(i-1)$  and  $d(i-2)$  is smaller than a predetermined value  $dc1$ . (step S13) When it is determined the former is smaller than the latter, that is, when the change in the vehicle-to-vehicle distance is large, it is determined that the vehicle 1 is accelerating relative to the forward vehicle. (step S14) Otherwise it is determined that the vehicle 1 is running at a constant distance from the forward vehicle since the degree of acceleration is low. (step S15)

When it is not determined in step S12 that the changes  $d(i)$ ,  $d(i-1)$  and  $d(i-2)$  are all negative or two of them are negative with the other being 0, it is determined whether or not the changes  $d(i)$ ,  $d(i-1)$  and  $d(i-2)$  are all positive or two of them are positive with the other being 0. (step S16) When it is determined that the changes  $d(i)$ ,  $d(i-1)$  and  $d(i-2)$  are all positive or two of them are positive with the other being 0, it is determined whether the sum of the changes  $d(i)$ ,  $d(i-1)$  and  $d(i-2)$  is larger than a predetermined value  $dc2$ . (step S17) When it is determined the former is larger than the latter, that is, when the change in the vehicle-to-vehicle distance is large, it is determined that the vehicle 1 is decelerating relative to the forward vehicle. (step S18) Otherwise it is determined that the vehicle 1 is running at a constant distance from the forward vehicle since the degree of deceleration is low. (step S15)

Thus when all the changes in the vehicle-to-vehicle distance in the last three intervals are not of the same sign (including 0), the running mode is determined to be the constant distance mode and the relative speed is calculated without changing the base point. Further even if all the changes in the vehicle-to-vehicle distance in the last three intervals are of the same sign (including 0), the change in the vehicle-to-vehicle distance is determined to be not abrupt and the running mode is determined to be the constant distance mode if the absolute value of the sum of the changes is smaller than a predetermined value. For example, in the part indicated at P3 in FIG. 6, though the three successive changes in the vehicle-to-vehicle distance are all positive, it is determined that the running mode is the constant distance mode since the change L3 in the elapsed time T3 is small. In this case, the relative speed is  $L3/T3$ .

Thus in the vehicle running mode detecting system of the present invention, the reference time is updated less frequently when the vehicle is running in the constant distance mode where the relative speed of the vehicle to the forward object need not be calculated so accurately than when the vehicle is running in a varying distance mode where the relative speed should be calculated accurately. Accordingly, the efficiency of calculating the relative speed can be improved.

What is claimed is:

1. A vehicle running mode detecting system comprising a relative speed calculating means which calculates the relative speed of a vehicle, equipped with the vehicle running mode detecting system, to a forward object on the basis of a time elapsed from a reference time based on which the time elapsed is measured and a change in the distance between the vehicle and the forward object during the time elapsed,

6

a running mode determining means which determines whether the vehicle is running in a constant distance mode where the distance between the vehicle and the forward object is kept substantially constant or in a varying distance mode where the vehicle is accelerating or decelerating relative to the forward object and the distance between the vehicle and the forward object is varying on the basis of the change in the distance between the vehicle and the forward object, and

a reference time updating means which receives an output of the running mode determining means and updates the reference time less frequently when the running mode determining means determines that the vehicle is running in the constant distance mode than when the running mode determining means determines that the vehicle is running in the varying distance mode.

2. A vehicle running mode detecting system as defined in claim 1 in which said reference time updating means updates the reference time at predetermined intervals which are set longer when the running mode determining means determines that the vehicle is running in the constant distance mode than when the running mode determining means determines that the vehicle is running in the varying distance mode.

3. A vehicle running mode detecting system as defined in claim 2 in which the running mode determining means determines that the vehicle is running in the constant distance mode unless the distance to the forward object decreases or increases continuously.

4. A vehicle running mode detecting system as defined in claim 3 in which the running mode determining means determines that the vehicle is running in the constant distance mode when the change in the distance to the forward object is small even if the distance to the forward object decreases or increases continuously.

5. A vehicle running mode detecting system as defined in claim 4 in which the reference time updating means updates the reference time when the running mode determining means keeps determining that the vehicle is running in the constant distance mode for a time not shorter than a predetermined time.

6. A vehicle running mode detecting system as defined in claim 1 in which the running mode determining means determines that the vehicle is running in the constant distance mode unless the distance to the forward object decreases or increases continuously.

7. A vehicle running mode detecting system as defined in claim 1 in which the running mode determining means determines that the vehicle is running in the constant distance mode when the change in the distance to the forward object is small even if the distance to the forward object decreases or increases continuously.

8. A vehicle running mode detecting system as defined in claim 1 in which the reference time updating means updates the reference time when the running mode determining means keeps determining that the vehicle is running in the constant distance mode for a time not shorter than a predetermined time.

9. A vehicle running mode detecting system comprising a relative speed calculating means which calculates the relative speed of a vehicle, equipped with the vehicle running mode detecting system, to a forward object on the basis of a time elapsed from a reference time based on which the time elapsed is measured and a change in the distance between the vehicle and the forward object during the time elapsed,



5,708,584

7

a running mode determining means which determines a degree of acceleration or deceleration of the vehicle relative to the forward object and a variation in the distance between the vehicle and the forward object on the basis of the change in the distance between the vehicle and the forward object, and

8

a reference time updating means which receives an output of the running mode determining means and updates the reference time more frequently as the degree of acceleration or deceleration of the vehicle increases.

\* \* \* \* \*

## **EXHIBIT 6**



**A. Identification of Infringed Claims and Applicable Statutory Section of 35 U.S.C. § 271**

Claims 1-2, 4-5, 7-8, 10, 12-13, 15, and 17-32 of U.S. Patent No. 5,954,781 are directly infringed under 35 U.S.C § 271(a) by the accused Audi vehicles identified below.

**B. Identification of Accused Instrumentalities By Claim**

As set forth in the accompanying claim chart, Audi's A3, A4, S4, A5, A5 Cabriolet, S5, S5 Cabriolet, RS5, A6, S6, A7, S7, RS7, A8, S8, S8, A8L, allroad, Q5, Q5 hybrid, SQ5, Q7, TT, TTS, TT Roadster, and TTS Roadster vehicles that include the identified features, infringe on or more of the claims identified above. On a claim-by-claim basis, the following Audi vehicles are accused of infringement by Velocity:

Claim 1 – Audi's A3, A4, S4, A5, A5 Cabriolet, S5, S5 Cabriolet, RS5, A6, S6, A7, S7, RS7, A8, S8, S8, A8L, allroad, Q5, Q5 hybrid, SQ5, Q7, TT, TTS, TT Roadster, and TTS Roadster;

Claim 2 - Audi's A3, A4, S4, A5, A5 Cabriolet, S5, S5 Cabriolet, RS5, A6, S6, A7, S7, RS7, A8, S8, S8, A8L, allroad, Q5, Q5 hybrid, SQ5, Q7, TT, TTS, TT Roadster, and TTS Roadster;

Claim 4 - Audi's A3, A4, S4, A5, A5 Cabriolet, S5, S5 Cabriolet, RS5, A6, S6, A7, S7, RS7, A8, S8, S8, A8L, allroad, Q5, Q5 hybrid, SQ5, Q7, TT, TTS, TT Roadster, and TTS Roadster;

Claim 5 - Audi's A3, A4, S4, A5, A5 Cabriolet, S5, S5 Cabriolet, RS5, A6, S6, A7, S7, RS7, A8, S8, S8, A8L, allroad, Q5, Q5 hybrid, SQ5, Q7, TT, TTS, TT Roadster, and TTS Roadster;

Claim 7 - Audi's A3, A4, S4, A5, A5 Cabriolet, S5, S5 Cabriolet, RS5, A6, S6, A7, S7, RS7, A8, S8, S8, A8L, allroad, Q5, Q5 hybrid, SQ5, Q7, TT, TTS, TT Roadster, and TTS Roadster;

Claim 8 - Audi's A3, A4, S4, A5, A5 Cabriolet, S5, S5 Cabriolet, RS5, A6, S6, A7, S7, RS7, A8, S8, S8, A8L, allroad, Q5, Q5 hybrid, SQ5, Q7, TT, TTS, TT Roadster, and TTS Roadster;

Claim 10 - Audi's A3, A4, S4, A5, A5 Cabriolet, S5, S5 Cabriolet, RS5, A6, S6, A7, S7, RS7, A8, S8, S8, A8L, allroad, Q5, Q5 hybrid, SQ5, Q7, TT, TTS, TT Roadster, and TTS Roadster;

Claim 12 - Audi's A3, A4, S4, A5, A5 Cabriolet, S5, S5 Cabriolet, RS5, A6, S6, A7, S7, RS7, A8, S8, S8, A8L, allroad, Q5, Q5 hybrid, SQ5, Q7, TT, TTS, TT Roadster, and TTS Roadster;

Claim 13 - Audi's A3, A4, S4, A5, A5 Cabriolet, S5, S5 Cabriolet, RS5, A6, S6, A7, S7, RS7, A8, S8, S8, A8L, allroad, Q5, Q5 hybrid, SQ5, Q7, TT, TTS, TT Roadster, and TTS Roadster;

Claim 15 - Audi's A3, A4, S4, A5, A5 Cabriolet, S5, S5 Cabriolet, RS5, A6, S6, A7, S7, RS7, A8, S8, S8, A8L, allroad, Q5, Q5 hybrid, SQ5, Q7, TT, TTS, TT Roadster, and TTS Roadster;

Claim 17 - Audi's A3, A4, S4, A5, A5 Cabriolet, S5, S5 Cabriolet, RS5, A6, S6, A7, S7, RS7, A8, S8, S8, A8L, allroad, Q5, Q5 hybrid, SQ5, and Q7;

Claim 18 - Audi's A3, A4, S4, A5, A5 Cabriolet, S5, S5 Cabriolet, RS5, A6, S6, A7, S7, RS7, A8, S8, S8, A8L, allroad, Q5, Q5 hybrid, SQ5, and Q7;

Claim 19 - Audi's A3, A4, S4, A5, A5 Cabriolet, S5, S5 Cabriolet, RS5, A6, S6, A7, S7, RS7, A8, S8, S8, A8L, allroad, Q5, Q5 hybrid, SQ5, and Q7;

Claim 20 - Audi's A3, A4, S4, A5, A5 Cabriolet, S5, S5 Cabriolet, RS5, A6, S6, A7, S7, RS7, A8, S8, S8, A8L, allroad, Q5, Q5 hybrid, SQ5, and Q7;

Claim 21 - Audi's A3, A4, S4, A5, A5 Cabriolet, S5, S5 Cabriolet, RS5, A6, S6, A7, S7, RS7, A8, S8, S8, A8L, allroad, Q5, Q5 hybrid, SQ5, and Q7;

Claim 22 - Audi's A3, A4, S4, A5, A5 Cabriolet, S5, S5 Cabriolet, RS5, A6, S6, A7, S7, RS7, A8, S8, S8, A8L, allroad, Q5, Q5 hybrid, SQ5, and Q7;

Claim 23 - Audi's A3, A4, S4, A5, A5 Cabriolet, S5, S5 Cabriolet, RS5, A6, S6, A7, S7, RS7, A8, S8, S8, A8L, allroad, Q5, Q5 hybrid, SQ5, and Q7;

Claim 24 - Audi's A3, A4, S4, A5, A5 Cabriolet, S5, S5 Cabriolet, RS5, A6, S6, A7, S7, RS7, A8, S8, S8, A8L, allroad, Q5, Q5 hybrid, SQ5, and Q7;

Claim 25 - Audi's A3, A4, S4, A5, A5 Cabriolet, S5, S5 Cabriolet, RS5, A6, S6, A7, S7, RS7, A8, S8, S8, A8L, allroad, Q5, Q5 hybrid, SQ5, and Q7;

Claim 26 - Audi's A3, A4, S4, A5, A5 Cabriolet, S5, S5 Cabriolet, RS5, A6, S6, A7, S7, RS7, A8, S8, S8, A8L, allroad, Q5, Q5 hybrid, SQ5, and Q7;

Claim 27 - Audi's A3, A4, S4, A5, A5 Cabriolet, S5, S5 Cabriolet, RS5, A6, S6, A7, S7, RS7, A8, S8, S8, A8L, allroad, Q5, Q5 hybrid, SQ5, and Q7;

Claim 28 - Audi's A3, A4, S4, A5, A5 Cabriolet, S5, S5 Cabriolet, RS5, A6, S6, A7, S7, RS7, A8, S8, S8, A8L, allroad, Q5, Q5 hybrid, SQ5, and Q7;

Claim 29 - Audi's A3, A4, S4, A5, A5 Cabriolet, S5, S5 Cabriolet, RS5, A6, S6, A7, S7, RS7, A8, S8, S8, A8L, allroad, Q5, Q5 hybrid, SQ5, and Q7;

Claim 30 - Audi's A3, A4, S4, A5, A5 Cabriolet, S5, S5 Cabriolet, RS5, A6, S6, A7, S7, RS7, A8, S8, S8, A8L, allroad, Q5, Q5 hybrid, SQ5, and Q7;

Claim 31 - Audi's A3, A4, S4, A5, A5 Cabriolet, S5, S5 Cabriolet, RS5, A6, S6, A7, S7, RS7, A8, S8, S8, A8L, allroad, Q5, Q5 hybrid, SQ5, and Q7;

Claim 32 - Audi's A3, A4, S4, A5, A5 Cabriolet, S5, S5 Cabriolet, RS5, A6, S6, A7, S7, RS7, A8, S8, S8, A8L, allroad, Q5, Q5 hybrid, SQ5, and Q7.

**C. Claim Chart Comparing Each Element of the Asserted Claims to the Accused Instrumentalities**

A claim chart identifying where each element of each asserted claim is found within each Accused Audi vehicle is attached.

**D. Identification of Whether Each Element of Each Asserted Claim is Present in the Accused Instrumentalities Literally or Under the Doctrine of Equivalents**

At this time, Velocity asserts that all of the asserted claim elements are literally present in the Accused Audi vehicles.

At this time, sections (e)-(f) of Local Patent Rule 2.2 are not applicable. Velocity expressly reserves the right to revise, amend and supplement these contentions as discovery progresses and new information becomes available.

Dated: April 8, 2014

Respectfully submitted,

/s/ James A. Shimota

James A. Shimota

James A. Shimota (IL Bar No. 6270603)

Howard E. Levin (IL Bar No. 6286712)

Adam R. Brausa (IL Bar No. 6292447)

Aaron C. Taggart (IL Bar No. 6302068)

MAVRAKAKIS LAW GROUP LLP

180 North LaSalle Street, Suite 2215

Chicago, Illinois 60601

Telephone: 312-216-1620

Facsimile: 312-216-1621

[jshimota@mavllp.com](mailto:jshimota@mavllp.com)

[hlevin@mavllp.com](mailto:hlevin@mavllp.com)

[abrausa@mavllp.com](mailto:abrausa@mavllp.com)

[ataggart@mavllp.com](mailto:ataggart@mavllp.com)

*Counsel for Plaintiff Velocity Patent LLC*

**PROOF OF SERVICE**

The undersigned hereby certifies that a true and correct copy of the above and foregoing document has been served on April 8, 2014, by electronic mail to:

<p><b>Miller, Canfield, Paddock and Stone, P.L.C</b></p> <p>Jeffrey M. Drake Ryan C. Williams 225 West Washington Street, Suite 2600 Chicago, IL 60606 (312) 460-4234 (312) 460-4228 <a href="mailto:drakej@millercanfield.com">drakej@millercanfield.com</a> <a href="mailto:williamsr@millercanfield.com">williamsr@millercanfield.com</a></p> <p><b>Served by Electronic Mail</b></p>	<p><b>Kenyon &amp; Kenyon LLP</b></p> <p>Susan A. Smith 1500 K. Street, N.W. Suite 700 Washington, DC 20005 (202) 220-4321 <a href="mailto:ssmith@kenyon.com">ssmith@kenyon.com</a></p> <p>Michael J. Lennon One Broadway New York, New York 10004 (212) 908-6439 <a href="mailto:mlennon@kenyon.com">mlennon@kenyon.com</a></p> <p><b>Served by Electronic Mail</b></p>
--	--

Attorneys for Defendant  
Audi of America, Inc.

*/s/ James C. Rally*

Project Assistant  
Mavrakakis Law Group LLP



**Velocity Patent LLC Preliminary Infringement Contentions Against Audi Defendants Pursuant to N.D. Ill. LPR 2.1**

Claim 1	Corresponding Element in Audi Vehicles <sup>1</sup>
1A. Apparatus for optimizing operation of a vehicle, comprising: <sup>2</sup>	<p>The accused Audi vehicles<sup>3</sup> include an apparatus for optimizing operation of a vehicle.</p> <p>For example, the accused Audi vehicles include computer-controlled vehicle systems with one or more computer processors that monitor various vehicle systems and optimize the fuel economy, safety and performance of the vehicle.</p>

---

<sup>1</sup> Velocity contends that the accused vehicles literally and directly infringe each element of the asserted claims.

<sup>2</sup> Velocity's citations related to any claim preamble in this claim chart should not be interpreted as an admission that the preamble is limiting.

<sup>3</sup> The accused features and vehicles identified in these preliminary contentions are representative only. Velocity accuses all Audi vehicle models for model years 2007 to 2014 that incorporate features that are similar to the accused features identified in these preliminary contentions, including the A3, A4, S4, A5, A5 Cabriolet, S5, S5 Cabriolet, RS5, A6, S6, A7, S7, RS7, A8, S8, S8, A8L, allroad, Q5, Q5 hybrid, SQ5, Q7, TT, TTS, TT Roadster, and TTS Roadster. Discovery has just begun in this case. Velocity reserves the right to supplement and identify additional infringing models (*e.g.*, 2015 models currently being tested) as it learns facts through discovery.

Claim 1	Corresponding Element in Audi Vehicles <sup>1</sup>
	<p data-bbox="813 436 948 464"><b>On-board computer</b></p> <p data-bbox="813 485 1081 541">You can call up the following information in the on-board computer:</p> <ul style="list-style-type: none"> <li data-bbox="813 562 854 590">-- Date</li> <li data-bbox="813 596 1094 653">-- Driving time (h) from the short-term memory</li> <li data-bbox="813 659 1073 716">-- Average consumption in MPG (l/100 km) from the short-term memory</li> <li data-bbox="813 722 1062 779">-- Average speed in mph (km/h) from the short-term memory</li> <li data-bbox="813 785 1062 842">-- Distance driven in miles (km) from the short-term memory</li> <li data-bbox="813 848 1073 905">-- Current fuel consumption in MPG (l/100 km)</li> <li data-bbox="813 911 1005 938">-- Short-term memory overview</li> <li data-bbox="813 945 1002 972">-- Long-term memory overview</li> </ul> <p data-bbox="813 999 1094 1182">The short-term memory collects driving information from the time the ignition is switched on until it is switched off. If you continue driving within two hours after switching the ignition off, the new values are included when calculating the current trip information.</p> <p data-bbox="813 1203 1094 1318">Unlike the short-term memory, the long-term memory is not erased automatically. You can select the time period for evaluating trip information yourself.</p> <p data-bbox="483 1381 1360 1675"><i>(See, e.g., Exhibits Audi-1, 2014 A7/S7 Owner's Manual at 26; Audi-2, 2014 A4/S4 Owner's Manual at 25-26; Audi-3, 2014 A5 Coupe/S5 Coupe Owner's Manual at 25-26; Audi-4, 2014 A5 Cabriolet/S5 Cabriolet Owner's Manual at 25-26; Audi-5, 2014 A6/S6 Owner's Manual at 26; Audi-6, 2014 Q5/SQ5 Owner's Manual at 23-24; Audi-7, 2014 Q7 Owner's Manual at 24-25; Audi-8, 2013 Audi A3 Owner's Manual at 25-26; Audi-9, 2013 A8/S8 Owner's Manual at 24-25; Audi-10, 2013 allroad Owner's Manual at 24-25; Audi-11, 2013 TT/TTS Roadster Owner's Manual at 23-24; Audi-12, 2013 TT/TTS/TT RS Coupe Owner's Manual at 23-24).</i></p>

Claim 1	Corresponding Element in Audi Vehicles <sup>1</sup>
<p>1B. a plurality of sensors coupled to a vehicle having an engine, said plurality of sensors, which collectively monitor operation of said vehicle, including a road speed sensor, an engine speed sensor, a manifold pressure sensor and a throttle position sensor;</p>	<p>The accused Audi vehicles include a plurality of sensors coupled to the vehicle having an engine, said plurality of sensors, which collectively monitor operation of said vehicle, including a road speed sensor, an engine speed sensor, a manifold pressure sensor and a throttle position sensor.</p> <p><i>See, e.g.</i>, citations for claim element 1A (describing processor controlled vehicle systems that monitor vehicle system characteristics and operations).</p> <p>More specifically, when equipped with an Audi 4.0L TFSI V8 engine, a 3.0L TFSI V6 engine, a 2.0L TFSI V4 engine, or a 1.8L TFSI V4 engine, the accused Audi vehicle includes a road speed sensor, an engine speed sensor, a manifold pressure sensor and a throttle position sensor coupled to the engine control module (“ECM”) of the vehicle:</p>

Claim 1	Corresponding Element in Audi Vehicles <sup>1</sup>
	<p><b>Engine Management</b></p> <p><b>System Overview</b></p> <p><b>Sensors</b></p> <p>Throttle Body Position Module 028      235 Throttle Drive Angle Sensor 0187/0106</p> <p>Steak Light Sensor F</p> <p>Crankshaft Position Sensor 045, 0188, 0206, 0207</p> <p>Accelerator Pedal Position Sensor 078      Accelerator Pedal Position Sensor 078/08</p> <p>Knock Sensors 1-4, 061, 070, 0199, 0198</p> <p>Low Fuel Pressure Sensor 040</p> <p>Decompressor Air Intake Sensor 1 0609</p> <p>Engine Coolant Temperature Sensor 032</p> <p>Engine Coolant Temperature Sensor on Radiator Outlet 1</p> <p>Oil Temperature Sensor 0289</p> <p>Engine Oil Pressure Control Sensor 0884</p> <p>Engine Oil Pressure Sensor 028</p> <p>Oil Level/Pressure Sensor 0290</p> <p>Intake Manifold Pressure Position Sensor 0398      Intake Manifold Pressure Position Sensor 1 0212</p> <p>Intake Air Temperature Sensor 042      Mass Air Flow Pressure Sensor 071</p> <p>Exhaust Pressure Sensor 0287      Exhaust Pressure Sensor 2 0214</p> <p>Engine Oil Temperature Sensor 0795</p> <p>Charge Air Pressure Sensor 027      Charge Air Pressure Sensor 2 0447</p> <p>Charge Air Temperature Sensors      Sensors 1-Low 1-0763, 0764</p> <p>Brake Booster Pressure Sensor 0284</p> <p>Heated Oxygen Sensors 1 and 2, 023 and 0208      Oxygen Sensor after Three-Way Catalyst Conversion 0186      Oxygen Sensor 2 after Three-Way Catalyst 0187</p> <p>Oil Pressure Switch 022      Reduced Oil Pressure Switch 0792      Oil Pressure Switch Level 0787</p> <p><b>Additional notes:</b></p> <ul style="list-style-type: none"> <li>- Vehicle specific</li> <li>- Vehicle specific</li> <li>- Start request to ECM</li> <li>- Request 1 = 0</li> <li>- Torque 02</li> <li>- Start signal</li> <li>- Monitoring</li> <li>- Control Module</li> </ul>



**Claim 1**

**Corresponding Element in Audi Vehicles<sup>1</sup>**

(See, e.g., Exhibit Audi-14, 3.0L V6 TFSI Self-Study Program at 44).

**Technical Description**

**Four Cylinder, Four Valve, FSI Turbocharged Gasoline Engine**

**Engine Block**

- Cast Iron Crankcase
- Balancer Shafts in Crankcase
- Forged Steel Crankshaft
- Self-Regulating Stamp-Mounted Oil Pump - Chain-Driven by Crankshaft
- Timing Case Cover - Front End of Engine
- Bolts - Chain Driven at Front End of Engine

**Cylinder Head**

- 4-Valve Cylinder Head
- 1.0L Intake Damper Air Adjuster
- Anti-Valve Lift System (V6/FSI on exhaust camshaft only)

**Intake Manifold**

- Turbo-Flap

**Fuel Supply**

- Demand Controlled on Low and High-Pressure Ends
- Multi-Port High-Pressure Injector

**Engine Management**

- MED 17 Engine Control
- Hot-Film Air Mass Flow with Integral Temperature Sensor
- Throttle Valve with Contactless Sensor
- Aira-Controlled Ignition with Cylinder-Selective Digital Knock Sensor
- Single-Spark Ignition Coils

**Turbocharging**

- Integral Exhaust Turbocharger
- Charge-Air Cooler
- Boost Pressure Control with Overpressure
- Electrical Diagnostic Valves

**Exhaust**

- Single-Chamber Exhaust System with Close-Coupled Pre-Catalyst

**Combustion Process**

- Fuel Straight Injection

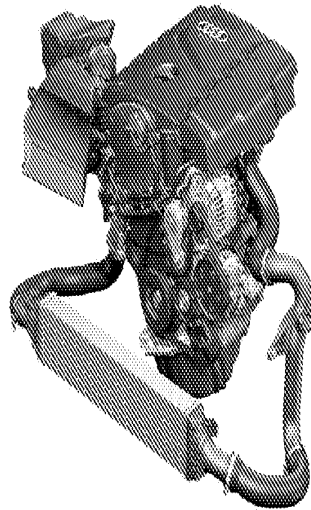

(See, e.g., Exhibit Audi-15, 2.0L V4 TFSI Self-Study Program at 2).

Claim 1	Corresponding Element in Audi Vehicles <sup>1</sup>
	<p>(See, e.g., Exhibit Audi-16, 1.8L V4 TFSI Self-Study Program at 36).</p>

Claim 1	Corresponding Element in Audi Vehicles <sup>1</sup>
	<p>(See also Exhibits Audi-1 at 11; Audi-2 at 10; Audi-3 at 10; Audi-4 at 10; Audi-5 at 11; Audi-6 at 10; Audi-7 at 10; Audi-8 at 10; Audi-9 at 10; Audi-10 at 10; Audi-11 at 10; Audi-12 at 10 (all showing displays coupled to sensors for engine speed and road speed)).</p> <p>Additionally, on information and belief, vehicles equipped with Audi's FSI and TDI engines also include a plurality of sensors, which collectively monitor operation of said vehicle, including a road speed sensor, an engine speed sensor, a manifold pressure sensor and a throttle position sensor coupled to the engine control module ("ECM") of the vehicle.</p>
<p>1C. a processor subsystem, coupled to each one of said plurality of sensors, to receive data therefrom;</p>	<p>The accused Audi vehicles include a processor subsystem, coupled to each one of said plurality of sensors, to receive data therefrom.</p>







Claim 1	Corresponding Element in Audi Vehicles <sup>1</sup>
<p>coupled to said processor subsystem, said memory subsystem storing therein a manifold pressure set point, an RPM set point, and present and prior levels for each one of said plurality of sensors;</p>	<p>processor subsystem, said memory subsystem storing therein a manifold pressure set point, an RPM set point, and present and prior levels for each one of said plurality of sensors.</p> <p>For example, the accused Audi vehicles include one or more memories that form a memory subsystem for storing information relating to vehicle system operations and features described in the vehicle manuals:</p>

Claim 1	Corresponding Element in Audi Vehicles <sup>1</sup>
	<p data-bbox="761 436 911 468">On-board computer</p> <p data-bbox="761 489 1062 552">You can call up the following information in the on-board computer:</p> <ul style="list-style-type: none"> <li data-bbox="761 575 808 602">-- Date</li> <li data-bbox="761 613 1076 676">-- Driving time (h) from the short-term memory</li> <li data-bbox="761 686 1052 749">-- Average consumption in MPG (l/100 km) from the short-term memory</li> <li data-bbox="761 760 1040 823">-- Average speed in mph (km/h) from the short-term memory</li> <li data-bbox="761 833 1036 896">-- Distance driven in miles (km) from the short-term memory</li> <li data-bbox="761 907 1052 970">-- Current fuel consumption in MPG (l/100 km)</li> <li data-bbox="761 980 976 1008">-- Short-term memory overview</li> <li data-bbox="761 1018 971 1045">-- Long-term memory overview</li> </ul> <p data-bbox="761 1066 1076 1266">The short-term memory collects driving information from the time the ignition is switched on until it is switched off. If you continue driving within two hours after switching the ignition off, the new values are included when calculating the current trip information.</p> <p data-bbox="761 1297 1076 1434">Unlike the short-term memory, the long-term memory is not erased automatically. You can select the time period for evaluating trip information yourself.</p> <p data-bbox="483 1486 1360 1612">(See, e.g., Exhibits Audi-1 at 26; Audi-2 at 25-26; Audi-3 at 25-26; Audi-4 at 25-26; Audi-5 at 26; Audi-6 at 23-24; Audi-7 at 24-25; Audi-8 at 25-26; Audi-9 at 24-26; Audi-10 at 24-25; Audi-11 at 23-24; Audi-12 at 23-24).</p>

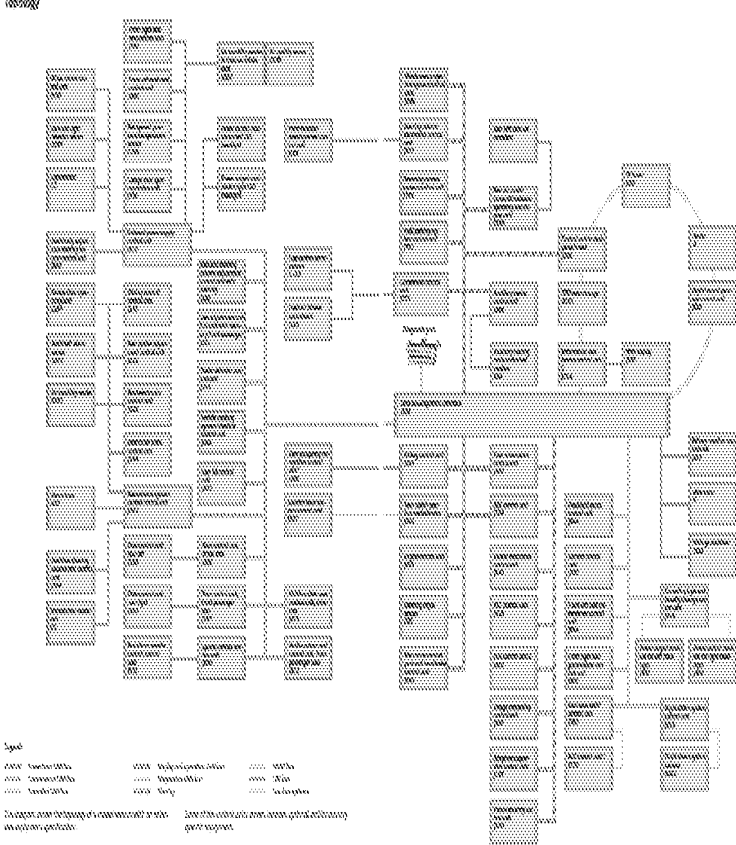

Claim 1	Corresponding Element in Audi Vehicles <sup>1</sup>
	<p>Technology</p>  <p>Legend:</p> <ul style="list-style-type: none"> <li>.....: 100% (Audi vehicle)</li> <li>.....: 75% (Audi vehicle)</li> <li>.....: 50% (Audi vehicle)</li> <li>.....: 25% (Audi vehicle)</li> <li>.....: 10% (Audi vehicle)</li> <li>.....: 5% (Audi vehicle)</li> <li>.....: 1% (Audi vehicle)</li> <li>.....: 0% (Audi vehicle)</li> </ul> <p>.....: 100% (Audi vehicle)</p> <p>.....: 75% (Audi vehicle)</p> <p>.....: 50% (Audi vehicle)</p> <p>.....: 25% (Audi vehicle)</p> <p>.....: 10% (Audi vehicle)</p> <p>.....: 5% (Audi vehicle)</p> <p>.....: 1% (Audi vehicle)</p> <p>.....: 0% (Audi vehicle)</p>
	<p>(See, e.g., Exhibit Audi-20, Audi A7 Sportback Onboard Power Supply and Networking Self-Study Program at 8-11).</p>

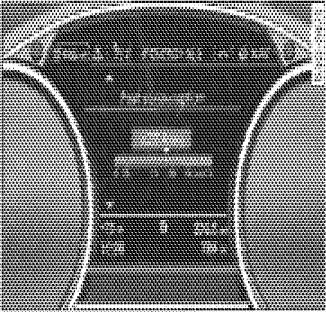

Claim 1	Corresponding Element in Audi Vehicles <sup>1</sup>
	<div data-bbox="738 436 1101 793" style="border: 1px solid black; padding: 5px; margin-bottom: 10px;"> <p><b>i</b> <b>Tips</b></p> <ul style="list-style-type: none"> <li>- If you switch the ignition or the adaptive cruise control off, the set speed is erased from the system memory.</li> <li>- You cannot switch the Electronic Stabilization Control (ESC) to the SPORT mode when adaptive cruise control is switched on.</li> </ul> </div> <p>(See, e.g., Exhibits Audi-1 at 89; Audi-2 at 103; Audi-3 at 94; Audi-4 at 96; Audi-5 at 87; Audi-6 at 110; Audi-7 at 114; Audi-9 at 96; Audi-10 at 94).</p>
<p>1E. a fuel overinjection notification circuit coupled to said processor subsystem, said fuel overinjection notification circuit issuing a notification that excessive fuel is being supplied to said engine of said vehicle;</p>	<p>The accused Audi vehicles include a fuel overinjection notification circuit coupled to said processor subsystem, said fuel overinjection notification circuit issuing a notification that excessive fuel is being supplied to said engine of said vehicle.</p> <p>For example, the accused Audi vehicles include one or more fuel overinjection notification circuits coupled to said processor subsystem:</p>

Claim 1	Corresponding Element in Audi Vehicles <sup>1</sup>
	<p data-bbox="760 449 1083 485"><b>Cylinder on Demand System</b></p> <p data-bbox="760 493 984 516">Applies to vehicles with 4.8 TFSI engine</p>  <p data-bbox="760 856 1024 884">Fig. 10 Instrument cluster: fuel consumption</p> <p data-bbox="760 919 1065 1058">To save fuel, the engine automatically turns four cylinders on or off, depending on the amount of power needed. This action is not felt by the passengers.</p> <p data-bbox="760 1087 954 1115"><b>Displaying cylinder mode</b></p> <p data-bbox="760 1140 1065 1203">Requirement: the on-board computer is displayed ⇒ page 26.</p> <ul data-bbox="760 1228 1073 1367" style="list-style-type: none"> <li>• Turn the thumbwheel until the current fuel consumption display is shown in the instrument cluster. If the green bar is displayed, you are driving in 4-cylinder mode.</li> </ul> <p data-bbox="483 1434 954 1472">(See, e.g., Audi-1 at 27; Audi-5 at 27; Audi-9 at 26).</p>



Claim 1	Corresponding Element in Audi Vehicles <sup>1</sup>
	<div data-bbox="782 443 1135 850" data-label="Image"> </div> <p data-bbox="782 856 1135 884">Fig. 3 Display: example of a fuel economy message</p> <p data-bbox="782 926 1135 1228">Fuel economy messages are displayed when fuel consumption is increased by certain conditions. If you follow these fuel economy messages, you can reduce your vehicle's consumption of fuel. The messages appear automatically and are only displayed in the efficiency program. The fuel economy messages turn off automatically after a certain period of time.</p> <ul data-bbox="782 1255 1135 1367" style="list-style-type: none"> <li>» To turn an economy message off immediately after it appears, press any button on the multifunction steering wheel.</li> </ul> <p data-bbox="483 1434 1360 1556">(See, e.g., Audi-1 at 27; Audi-2 at 27-28; Audi-3 at 28-29; Audi-4 at 27-28; Audi-5 at 27; Audi-6 at 25-26; Audi-7 at 27; Audi-8 at 29-30; Audi-9 at 25-26; Audi-10 at 26-27; Audi-11 at 27; Audi-12 at 27).</p>



Claim 1	Corresponding Element in Audi Vehicles <sup>1</sup>
	<p data-bbox="727 449 1122 751">The current fuel consumption can be displayed using a bar ⇒ page 27, fig. 10. The average consumption (mpg) stored in the short-term memory is also displayed. Electrical energy can be stored in the battery when the vehicle is coasting or driving downhill (recuperation). The bar will move toward □.</p> <p data-bbox="483 814 1360 934">(See, e.g., Audi-1 at 26; Audi-2 at 25-26; Audi-3 at 25-26; Audi-4 at 25-26; Audi-5 at 26; Audi-6 at 23-24; Audi-7 at 24-25; Audi-8 at 25-26; Audi-9 at 25; Audi-10 at 24-25; Audi-11 at 23-24; Audi-12 at 23-24).</p>

Claim 1	Corresponding Element in Audi Vehicles <sup>1</sup>
	<p data-bbox="711 457 1117 506"><b>Speed warning system</b></p> <p data-bbox="711 537 846 583"><b>Installation</b></p> <p data-bbox="711 617 1117 699"><i>The speed warning system helps you to stay under a specified maximum speed.</i></p> <p data-bbox="711 743 1133 1209">The speed warning system warns you if you are exceeding the maximum speed that you have set. You will hear a warning tone when your speed exceeds the stored value by approximately 3 mph (3 km/h). An indicator light  (USA models)/ (Canada models) in the instrument cluster display also turns on at the same time. The indicator light  turns off when the speed decreases below the stored maximum speed.</p> <p data-bbox="711 1247 1133 1520">Setting a threshold is recommended if you would like to be reminded when you reach a certain maximum speed. Situations where you may want to do so include driving in a country with a general speed limit or if there is a specified maximum speed for winter tires.</p> <p data-bbox="483 1587 1360 1707"><i>(See, e.g., Audi-1 at 84; Audi-2 at 87-88; Audi-3 at 78-79; Audi-4 at 81-82; Audi-5 at 82; Audi-6 at 93-94; Audi-7 at 28-29; Audi-8 at 31-32; Audi-9 at 90; Audi-10 at 81-82; Audi-11 at 76-77; Audi-12 at 74-75).</i></p>

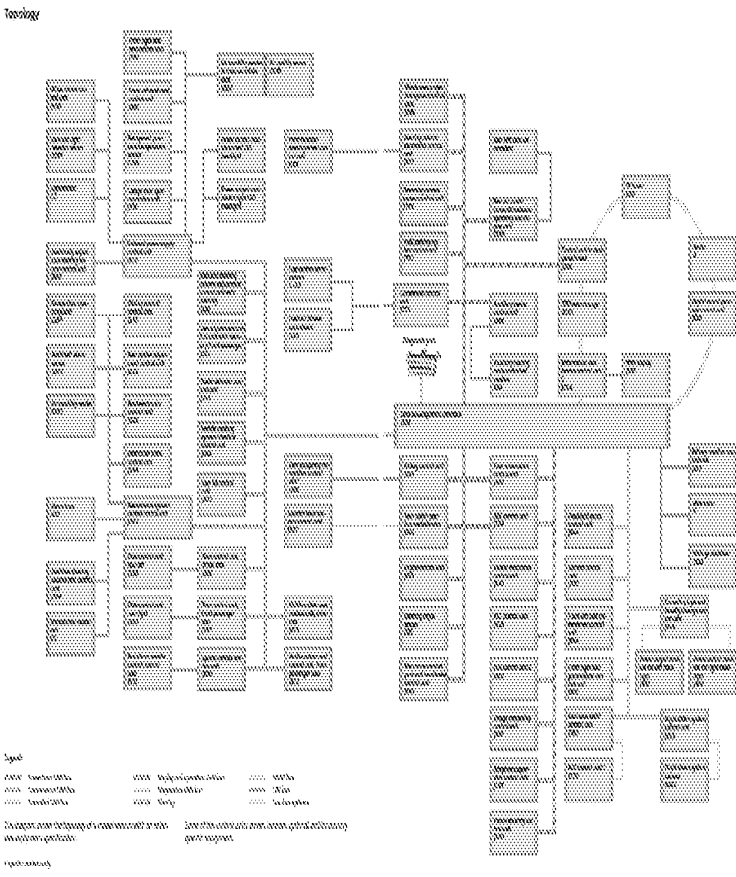

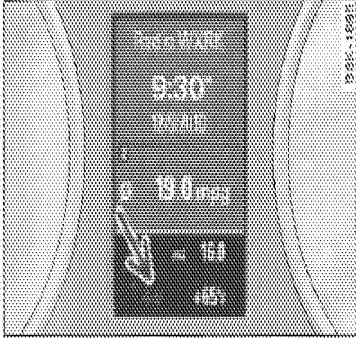

Claim 1	Corresponding Element in Audi Vehicles <sup>1</sup>
	 <p>(See, e.g., Exhibit Audi-20, Audi A7 Sportback Onboard Power Supply and Networking Self-Study Program at 8-11).</p>
<p>1F. an upshift notification circuit coupled to said processor subsystem, said upshift notification circuit issuing a notification that</p>	<p>The accused Audi vehicles include an upshift notification circuit coupled to said processor subsystem, said upshift notification circuit issuing a notification that said engine of said vehicle is being operated at an excessive speed.</p> <p>For example, the accused Audi vehicles include one or more upshift notification circuits coupled</p>

Claim 1	Corresponding Element in Audi Vehicles <sup>1</sup>
<p>said engine of said vehicle is being operated at an excessive speed;</p>	<p>to said processor subsystem, said upshift notification circuit issuing a notification that said engine of said vehicle is being operated at an excessive speed.</p> <p style="text-align: center;"><b>Efficiency program</b></p> <p style="text-align: center;">The efficiency program can help you to use less fuel. It evaluates driving information in reference to fuel consumption and shows other equipment influencing consumption as well as shift recommendations. ⇨ page 26. Fuel economy messages ⇨ page 27 provide tips for efficient driving. The efficiency program uses distance and consumption data from trip computer 1.</p> <p>(See, e.g., Exhibits Audi-1 at 26; Audi-2 at 27-28; Audi-3 at 27-28; Audi-4 at 27; Audi-5 at 26; Audi-6 at 25; Audi-7 at 26; Audi-8 at 29; Audi-9 at 25; Audi-10 at 26; Audi-11 at 26-27; Audi-12 at 26-27).</p>

Claim 1	Corresponding Element in Audi Vehicles <sup>1</sup>
	<p data-bbox="745 428 1031 468"><b>Gearshift Indicator</b></p> <p data-bbox="745 480 1088 535"><i>Applies to vehicles with manual transmission and gearshift indicator</i></p> <p data-bbox="745 558 1031 590"><i>This indicator can help conserve fuel.</i></p>  <p data-bbox="751 966 971 991">Fig. 12 Display: Gearshift indicator</p> <p data-bbox="745 1035 1101 1341">In order to become familiar with the gearshift indicator, at first just drive the way you are used to. If the current gear - and the driving situation - is not the best one for conserving fuel, then the indicator will display the recommended gear. The display shows the current gear and the gear that is recommended  </p> <p data-bbox="745 1369 1081 1480">- <b>Upshifting</b> The display will light up to the right of the gear currently selected if it is recommending a higher gear.</p>

Claim 1	Corresponding Element in Audi Vehicles <sup>1</sup>
	<p data-bbox="764 436 1073 533">-- Downshifting: The display will light up to the left of the gear currently selected if it is recommending a lower gear.</p> <p data-bbox="764 558 1045 621">Sometimes the indicator will recommend skipping a gear (3 &gt; 5).</p> <p data-bbox="764 646 1073 743">If there is no gearshift recommendation, then just drive in the appropriate gear for conserving fuel.</p> <p data-bbox="483 800 1032 842"><i>(See, e.g., Exhibits Audi-2 at 27; Audi-3 at 27; Audi-8 at 24).</i></p>

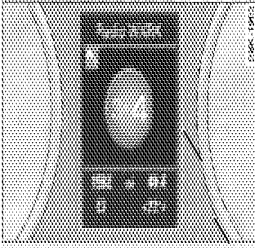

Claim 1	Corresponding Element in Audi Vehicles <sup>1</sup>						
	<p data-bbox="794 436 1047 510">              Applies to vehicles with manual transmission and trip computer with efficiency program         </p> <p data-bbox="794 527 1047 772">  </p> <p data-bbox="794 772 1047 800"> <i>Fig. 14 Display, enhanced shift indicator</i> </p> <p data-bbox="794 825 1047 930">           ▶ In the efficiency program, press the function selection switch ⇒ page 26, fig. 11 (3) repeatedly until the enhanced shift indicator appears in the display.         </p> <p data-bbox="794 953 1047 1119">           The efficiency program also has an enhanced shift indicator. This enhanced shift indicator follows the same concept as the "standard" shift indicator ⇒ page 27. The selected and the recommended gears are highlighted in colors like a traffic light.         </p> <p data-bbox="794 1140 1047 1220">           The color of the circle indicates if the most suitable gear is engaged or if you should shift up or down.         </p> <table border="1" data-bbox="794 1230 1047 1419"> <tr> <td data-bbox="794 1230 917 1318">Green circle without or with a gear</td> <td data-bbox="917 1230 1047 1318">No gear or the most suitable gear is engaged</td> </tr> <tr> <td data-bbox="794 1318 917 1381">Yellow circle ⇒ fig. 14</td> <td data-bbox="917 1318 1047 1381">Shift up or down one gear</td> </tr> <tr> <td data-bbox="794 1381 917 1419">Red circle</td> <td data-bbox="917 1381 1047 1419">Shift up two gears</td> </tr> </table> <p data-bbox="794 1434 1047 1591">  <b>Note</b>            This enhanced shift indicator can help you conserve fuel. It is not designed to recommend the correct gear in all driving situations. Only the driver can decide which         </p> <p data-bbox="483 1671 911 1711"> <i>(See, e.g., Exhibits Audi-2 at 28; Audi-3 at 28).</i> </p>	Green circle without or with a gear	No gear or the most suitable gear is engaged	Yellow circle ⇒ fig. 14	Shift up or down one gear	Red circle	Shift up two gears
Green circle without or with a gear	No gear or the most suitable gear is engaged						
Yellow circle ⇒ fig. 14	Shift up or down one gear						
Red circle	Shift up two gears						

Claim 1

Corresponding Element in Audi Vehicles<sup>1</sup>

Control unit with display in dash panel insert

The optimal indicator

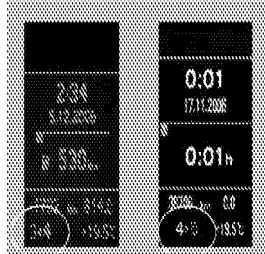

dash insert 010101 010101 010101 010101 010101 010101 010101 010101 010101 010101

Function

The optimal indicator in the driver information system is a new function designed to help the driver to reduce fuel consumption. The function is integrated in the engine management software. It is featured in all petrol and diesel models with recent gearbox.

As modern vehicle engines deliver high torque even at low rpm, it is often possible to drive in a higher gear. In this case, a gearbox recommendation is indicated to the driver on the driver information system. The gearbox recommendation may involve skipping a gear.

The actual gear position is indicated continuously to the driver information system. The information is derived from the actual engine speed and road speed signals. Further, the actual gear position and any gearbox recommendations are indicated while the clutch is actuated for longer than 2 seconds. No gearbox recommendation is given when the engine is operating at full throttle either.

Normally no gearbox recommendation is issued when the vehicle is in a gear. However, if the engine speed drops below a critical threshold, a recommendation to shift down a gear will be given.

To implement the "optimal indicator" function, the engine control unit also requires information from the steering angle sensor G86, the ABS control unit J285 and the transmission system control unit J282. The engine control unit receives this information via CAN bus.

Indicator

The gearbox recommendations conveyed by the engine control unit is transmitted via CAN bus to the dash panel unit and displayed in the driver information system. There are two possible states of the display:

- 1 The actual gear position is displayed with or without a gearbox recommendation.
- 2 No display. This is the case if the clutch is actuated for longer than two seconds or if the driver has disengaged the function or the gear.

Claim 1	Corresponding Element in Audi Vehicles <sup>1</sup>
	<p>(See, e.g., Exhibit Audi-21, Audi A5 Convenience Electronics and Drive Assist Systems Self-Study Program at 12).</p> <p style="text-align: center;"><b>All of the performance for all of the senses</b></p> <p style="text-align: center;">The dynamic steering adjusts to road and weather conditions. The RS 7 exclusive head up LED shift indicators reveal the precise moment to unleash the next gear. And a transmission tuned for an ultra-responsive, G-inducing throttle. All designed to maximize every exhilarating aspect of the driving experience.</p> <p>(See, e.g., Exhibit Audi-17, 2014 RS7 Specification at 3).</p> <p style="text-align: center;"> <b>Transmission overheating; Please drive conservatively</b></p> <p style="text-align: center;">The transmission temperature has increased significantly due to the sporty driving manner. Drive in a less sporty manner until the temperature returns to the normal range and the indicator light switches off.</p> <p>(See, e.g., Exhibits Audi-1 at 114; Audi-2 at 97; Audi-3 at 88; Audi-4 at 91; Audi-5 at 112-13; Audi-6 at 128; Audi-7 at 128; Audi-9 at 119; Audi-10 at 89).</p>

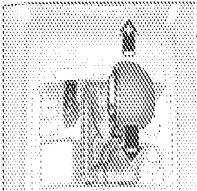
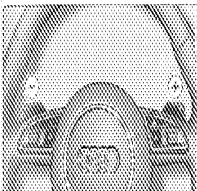
Claim 1	Corresponding Element in Audi Vehicles <sup>1</sup>
	<div style="text-align: right; margin-bottom: 10px;">Automatic Transmission 2</div> <div style="display: flex; justify-content: space-between;"> <div style="width: 45%;"> <p><b>Automatic Transmission</b></p> <p>will descend a level of engine speed operational limitations, so it may not be able to maintain a constant speed or gear at certain conditions. Always be ready to apply the brakes.</p> <hr/> <p><b>Audi 2 vehicle with 2 transmission</b></p> <p>Using the manual shift program you can manually select gears.</p>  <p>Fig. 128. Using manual shift program</p>  <p>Fig. 129. Selector lever with buttons</p> <p><b>Gear selection with selector lever</b></p> <p>The S-tronic mode can be selected either with the vehicle stationary or on the move.</p> <ul style="list-style-type: none"> <li>▶ To push the selector lever to the right from D/S, an M appears in the instrument cluster display as soon as the transmission has shifted.</li> <li>▶ To upshift, push the selector lever forward to the plus position (➕) (Fig. 129).</li> <li>▶ To downshift, push the lever to the minus position (➖).</li> </ul> </div> <div style="width: 50%;"> <p><b>Gear selection with paddle levers*</b></p> <p>The shift buttons are activated when the selector lever is in D/S or the S-tronic manual shift program.</p> <ul style="list-style-type: none"> <li>▶ To upshift, touch the button on the right (➕) (Fig. 129).</li> <li>▶ To downshift, touch the button on the left (➖).</li> </ul> <p>The transmission automatically shifts up or down before critical engine speed is reached.</p> <p>The transmission only allow manual shifting when the engine speed is within the permitted range.</p> <hr/> <p><b>Tip</b></p> <ul style="list-style-type: none"> <li>- When you shift into the next lower gear, the transmission will downshift only when there is no possibility of over-revving the engine.</li> <li>- When the kick-down function, the transmission will shift down to a lower gear, depending on vehicle and engine speeds.</li> <li>- Tiptronic is cooperative when the transmission is in the full-stake mode.</li> </ul> <hr/> <p><b>Audi 2 vehicle with 2 transmission</b></p> <p><b>Kick-down enables maximum acceleration</b></p> <p>When you depress the accelerator pedal beyond the resistance point, the automatic transmission downshifts into a lower gear, depending on vehicle speed and engine speed. The upshift into the next higher gear takes place once the maximum specified engine speed is reached.</p> <hr/> <p><b>Automatic Transmission</b></p> <p>Please note that the driver always can spin a kick-down is used on a smooth city road, there is a risk of spinning.</p> </div> </div>

(See, e.g., Exhibits Audi-1 at 113; Audi-2 at 96; Audi-3 at 86-87; Audi-4 at 89-90; Audi-5 at 111; Audi-6 at 127; Audi-7 at 140-41; Audi-8 at 99-100; Audi-9 at 118; Audi-10 at 89; Audi-11 at 85-86; Audi-12 at 84).

**Claim 1**

**Corresponding Element in Audi Vehicles<sup>1</sup>**

**Networking**

Installation locations of the control units

Notes: 1. The control units are located in the engine compartment.

2. The control units are located in the trunk of the vehicle.

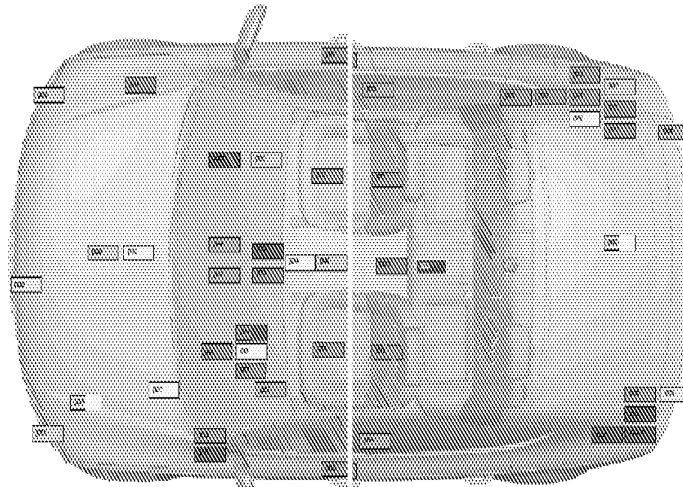

Legend:

- 100 Control unit for engine control
- 101 Control unit for transmission control
- 102 Control unit for ABS
- 103 Control unit for ESP
- 104 Control unit for steering
- 105 Control unit for suspension
- 106 Control unit for air conditioning
- 107 Control unit for climate control
- 108 Control unit for infotainment
- 109 Control unit for navigation
- 110 Control unit for telematics
- 111 Control unit for security
- 112 Control unit for immobilizer
- 113 Control unit for anti-theft
- 114 Control unit for alarm

- 200 Control unit for engine control
- 201 Control unit for transmission control
- 202 Control unit for ABS
- 203 Control unit for ESP
- 204 Control unit for steering
- 205 Control unit for suspension
- 206 Control unit for air conditioning
- 207 Control unit for climate control
- 208 Control unit for infotainment
- 209 Control unit for navigation
- 210 Control unit for telematics
- 211 Control unit for security
- 212 Control unit for immobilizer
- 213 Control unit for anti-theft
- 214 Control unit for alarm

- 300 Control unit for engine control
- 301 Control unit for transmission control
- 302 Control unit for ABS
- 303 Control unit for ESP
- 304 Control unit for steering
- 305 Control unit for suspension
- 306 Control unit for air conditioning
- 307 Control unit for climate control
- 308 Control unit for infotainment
- 309 Control unit for navigation
- 310 Control unit for telematics
- 311 Control unit for security
- 312 Control unit for immobilizer
- 313 Control unit for anti-theft
- 314 Control unit for alarm

- 400 Control unit for engine control
- 401 Control unit for transmission control
- 402 Control unit for ABS
- 403 Control unit for ESP
- 404 Control unit for steering
- 405 Control unit for suspension
- 406 Control unit for air conditioning
- 407 Control unit for climate control
- 408 Control unit for infotainment
- 409 Control unit for navigation
- 410 Control unit for telematics
- 411 Control unit for security
- 412 Control unit for immobilizer
- 413 Control unit for anti-theft
- 414 Control unit for alarm

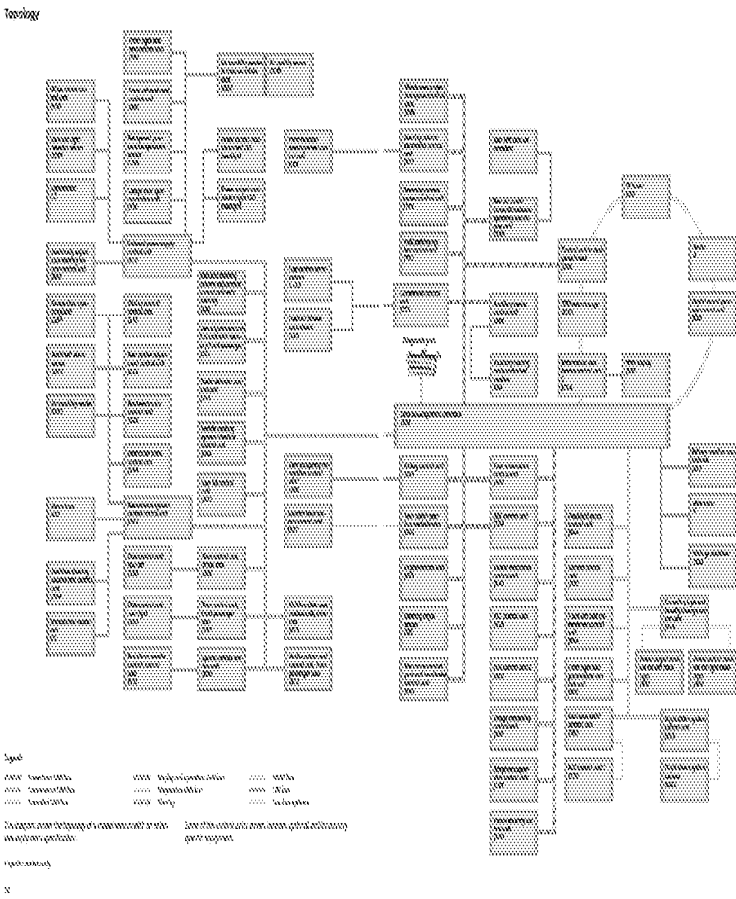
Claim 1	Corresponding Element in Audi Vehicles <sup>1</sup>
	 <p>(See, e.g., Exhibit Audi-20, Audi A7 Sportback Onboard Power Supply and Networking Self-Study Program at 8-11).</p>
<p>1G. said processor subsystem determining, based upon data received from said plurality of</p>	<p>On information and belief, the accused Audi vehicles include a processor subsystem that determines based upon data received from said plurality of sensors, when to activate said fuel overinjection circuit and when to activate said upshift notification circuit.</p>

Claim 1	Corresponding Element in Audi Vehicles <sup>1</sup>
sensors, when to activate said fuel overinjection circuit and when to activate said upshift notification circuit.	<i>See, e.g.</i> , citations for elements 1A-1F.

Claim 2	Corresponding Element in Audi Vehicles
2A. Apparatus for optimizing operation of a vehicle according to claim 1 wherein said processor subsystem further comprises:	<p>The accused Audi vehicles include an apparatus for optimizing operation of a vehicle according to claim 1 wherein said processor subsystem further comprises:</p> <p><i>See, e.g.</i>, citations for claim 1.</p>
2B. means for determining when road speed for said vehicle is increasing;	<p>The accused Audi vehicles include a means for determining when road speed for said vehicle is increasing.</p> <p><i>See, e.g.</i>, citations for claim elements 1B-1D.</p> <p>To the extent that 35 U.S.C. §112(6) applies to this claim limitation, the structure(s), act(s), or materials(s) that perform the claimed function of “determining when road speed for said vehicle is increasing” are described in, for example, Figures 1 and 2 and associated text of the ’781 patent relating to Road Speed Sensor 18, Memory Subsystem 14, and Processor Subsystem 12.</p>
2C. means for determining when throttle position for said vehicle is increasing; and	<p>The accused Audi vehicles include a means for determining when throttle position for said vehicle is increasing.</p> <p><i>See, e.g.</i>, citations for claim elements 1B-1D.</p> <p>To the extent that 35 U.S.C. §112(6) applies to this claim limitation, the structure(s), act(s), or materials(s) that perform the claimed function of “determining when throttle position for said vehicle is increasing” are described in, for example, Figures 1 and 2 and associated text of the ’781 patent relating to Throttle Sensor 24, Memory Subsystem 14, and Processor Subsystem 12.</p>
2D. means for comparing manifold pressure to said manifold pressure set point;	<p>The accused Audi vehicles include a means for comparing manifold pressure to said manifold pressure set point.</p> <p><i>See, e.g.</i>, citations for claim elements 1B-1D.</p>



Claim 2	Corresponding Element in Audi Vehicles
	<p>To the extent that 35 U.S.C. §112(6) applies to this claim limitation, the structure(s), act(s), or materials(s) that perform the claimed function of “comparing manifold pressure to said manifold pressure set point” are described in, for example, Figures 1 and 2 and associated text of the '781 patent relating to Manifold PSI Sensor 22, Memory Subsystem 14, and Processor Subsystem 12.</p>
<p>2E. said processor subsystem activating said fuel overinjection notification circuit if both road speed and throttle position for said vehicle are increasing and manifold pressure for said vehicle is above said manifold pressure set point.</p>	<p>On information and belief, the accused Audi vehicles include a processor subsystem that activates said fuel overinjection notification circuit if both road speed and throttle position for said vehicle are increasing and manifold pressure for said vehicle is above said manifold pressure set point.</p> <p><i>See, e.g.,</i> citations for claim elements 1E, 1G.</p>

Claim 4	Corresponding Element in Audi Vehicles
4A. Apparatus for optimizing operation of a vehicle according to claim 1 wherein said processor subsystem further comprises:	<p>The accused Audi vehicles include an apparatus for optimizing operation of a vehicle according to claim 1 wherein said processor subsystem further comprises:</p> <p><i>See, e.g.,</i> citations for claim 1.</p>
4B. means for determining when road speed for said vehicle is decreasing;	<p>The accused Audi vehicles include a means for determining when road speed for said vehicle is decreasing.</p> <p><i>See, e.g.,</i> citations for claim element 2B.</p> <p>To the extent that 35 U.S.C. §112(6) applies to this claim limitation, the structure(s), act(s), or materials(s) that perform the claimed function of “determining when road speed for said vehicle is decreasing” are described in, for example, Figures 1 and 2 and associated text of the ’781 patent relating to Road Speed Sensor 18, Memory Subsystem 14, and Processor Subsystem 12.</p>
4C. means for determining when throttle position for said vehicle is increasing; and	<p>The accused Audi vehicles include a means for determining when throttle position for said vehicle is increasing.</p> <p><i>See, e.g.,</i> citations for claim element 2C.</p>
4D. means for determining when manifold pressure for said vehicle is increasing; and	<p>The accused Audi vehicles include a means for determining when manifold pressure for said vehicle is increasing.</p> <p><i>See, e.g.,</i> citations for claim elements 1B-1D.</p> <p>To the extent that 35 U.S.C. §112(6) applies to this claim limitation, the structure(s), act(s), or materials(s) that perform the claimed function of “determining when manifold pressure for said vehicle is increasing” are described in, for example, Figures 1 and 2 and associated text of the ’781 patent relating to Manifold PSI Sensor 22, Memory Subsystem 14, and Processor</p>

Claim 4	Corresponding Element in Audi Vehicles
	Subsystem 12.
4E. means for determining when engine speed for said vehicle is decreasing;	<p>The accused Audi vehicles include a means for determining when engine speed for said vehicle is decreasing.</p> <p><i>See, e.g.,</i> citations for claim elements 1B-1D.</p> <p>To the extent that 35 U.S.C. §112(6) applies to this claim limitation, the structure(s), act(s), or materials(s) that perform the claimed function of “determining when engine speed for said vehicle is decreasing” are described in, for example, Figures 1 and 2 and associated text of the ’781 patent relating to RPM Sensor 20, Memory Subsystem 14, and Processor Subsystem 12.</p>
4F. said processor subsystem activating said fuel overinjection notification circuit if both throttle position and manifold pressure for said vehicle are increasing and road speed and engine speed for said vehicle are decreasing.	<p>On information and belief, the accused Audi vehicles include a processor subsystem that activates said fuel overinjection notification circuit if both throttle position and manifold pressure for said vehicle are increasing and road speed and engine speed for said vehicle are decreasing.</p> <p><i>See, e.g.,</i> citations for claim elements 1E, 1G.</p>

Claim 5	Corresponding Element in Audi Vehicles
5A. Apparatus for optimizing operation of a vehicle according to claim 1 wherein said processor subsystem further comprises:	The accused Audi vehicles include an apparatus for optimizing operation of a vehicle according to claim 1 wherein said processor subsystem further comprises:  <i>See, e.g.,</i> citations for claim 1.
5B. means for determining when road speed for said vehicle is increasing;	The accused Audi vehicles include a means for determining when road speed for said vehicle is increasing.  <i>See, e.g.,</i> citations for claim element 2B.
5C. means for determining when throttle position for said vehicle is increasing; and	The accused Audi vehicles include a means for determining when throttle position for said vehicle is increasing.  <i>See, e.g.,</i> citations for claim element 2C.
5D. means for comparing manifold pressure to said manifold pressure set point;	The accused Audi vehicles include a means for comparing manifold pressure to said manifold pressure set point.  <i>See, e.g.,</i> citations for claim element 2D.
5E. means for comparing engine speed to said RPM set point;	The accused Audi vehicles include a means for comparing engine speed to said RPM set point.  <i>See, e.g.,</i> citations for claim elements 1B-1D.  To the extent that 35 U.S.C. §112(6) applies to this claim limitation, the structure(s), act(s), or materials(s) that perform the claimed function of “determining when engine speed for said vehicle is decreasing” are described in, for example, Figures 1 and 2 and associated text of the '781 patent relating to RPM Sensor 20, Memory Subsystem 14, and Processor Subsystem 12.
5F. said processor subsystem activating said	On information and belief, the accused Audi vehicles include a processor subsystem that activates said upshift notification circuit if both road speed and throttle position for said vehicle

Claim 5	Corresponding Element in Audi Vehicles
<p>upshift notification circuit if both road speed and throttle position for said vehicle are increasing, manifold pressure for said vehicle is at or below said manifold pressure set point and engine speed for said vehicle is at or above said RPM set point.</p>	<p>are increasing, manifold pressure for said vehicle is at or below said manifold pressure set point and engine speed for said vehicle is at or above said RPM set point.</p> <p><i>See, e.g.,</i> citations for claim elements 1F, 1G.</p>

Claim 7	Corresponding Element in Audi Vehicles
7A. Apparatus for optimizing operation of a vehicle, comprising:	The accused Audi vehicles include an apparatus for optimizing operation of a vehicle.  <i>See, e.g.,</i> citations for claim 1.
7B. a plurality of sensors coupled to a vehicle having an engine, said plurality of sensors, which collectively monitor operation of said vehicle, including a road speed sensor, a manifold pressure sensor and a throttle position sensor;	The accused Audi vehicles include a plurality of sensors coupled to a vehicle having an engine, said plurality of sensors, which collectively monitor operation of said vehicle, including a road speed sensor, a manifold pressure sensor and a throttle position sensor;  <i>See, e.g.,</i> citations for claim element 1B.
7C. a processor subsystem, coupled to each one of said plurality of sensors, to receive data therefrom;	The accused Audi vehicles include a processor subsystem, coupled to each one of said plurality of sensors, to receive data therefrom.  <i>See, e.g.,</i> citations for claim element 1C.
7D. a memory subsystem, coupled to said processor subsystem, said memory subsystem storing therein a manifold pressure set point and present and prior levels for each one of said plurality of sensors;	The accused Audi vehicles include a memory subsystem, coupled to said processor subsystem, said memory subsystem storing therein a manifold pressure set point and present and prior levels for each one of said plurality of sensors;  <i>See, e.g.,</i> citations for claim element 1D.
7E. a fuel overinjection notification circuit coupled to said processor subsystem, said fuel overinjection	The accused Audi vehicles include a fuel overinjection notification circuit coupled to said processor subsystem, said fuel overinjection notification circuit issuing a notification that excessive fuel is being supplied to said engine of said vehicle;

Claim 7	Corresponding Element in Audi Vehicles
notification circuit issuing a notification that excessive fuel is being supplied to said engine of said vehicle;	<i>See, e.g.</i> , citations for claim element 1E.
7F. a downshift notification circuit coupled to said processor subsystem, said downshift notification circuit issuing a notification that said engine of said vehicle is being operated at an insufficient engine speed; and	<p>The accused Audi vehicles include a downshift notification circuit coupled to said processor subsystem, said downshift notification circuit issuing a notification that said engine of said vehicle is being operated at an insufficient engine speed; and</p> <p>For example, the accused Audi vehicles include one or more downshift notification circuits coupled to said processor subsystem, said downshift notification circuit issuing a notification that said engine of said vehicle is being operated at an insufficient speed.</p> <p style="text-align: center;"><b>Efficiency program</b></p> <p style="text-align: center;">The efficiency program can help you to use less fuel. It evaluates driving information in reference to fuel consumption and shows other equipment influencing consumption as well as shift recommendations. ⇨ page 26. Fuel economy messages ⇨ page 27 provide tips for efficient driving. The efficiency program uses distance and consumption data from trip computer 1.</p> <p>(<i>See, e.g.</i>, Exhibits Audi-1 at 26; Audi-2 at 27-28; Audi-3 at 27-28; Audi-4 at 27; Audi-5 at 26; Audi-6 at 25; Audi-7 at 26; Audi-8 at 29; Audi-9 at 25; Audi-10 at 26; Audi-11 at 26-27; Audi-12 at 26-27).</p>

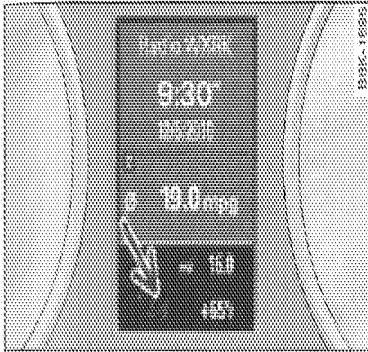
Claim 7	Corresponding Element in Audi Vehicles
	<p data-bbox="740 432 1032 474"><b>Gearshift Indicator</b></p> <p data-bbox="740 485 1094 541">Applies to vehicles with manual transmission and gearshift indicator</p> <p data-bbox="740 562 1032 596"><i>This indicator can help conserve fuel.</i></p>  <p data-bbox="740 982 971 1012">Fig. 12. Display: Gearshift indicator</p> <p data-bbox="740 1056 1105 1373">In order to become familiar with the gearshift indicator, at first just drive the way you are used to. If the current gear - and the driving situation - is not the best one for conserving fuel, then the indicator will display the recommended gear. The display shows the current gear and the gear that is recommended  ⇨ fig. 12.</p> <p data-bbox="740 1402 1084 1520">- <b>Upshifting</b> The display will light up to the right of the gear currently selected if it is recommending a higher gear.</p>



Claim 7	Corresponding Element in Audi Vehicles
	<p data-bbox="740 436 1096 552">-- Downshifting: The display will light up to the left of the gear currently selected if it is recommending a lower gear.</p> <p data-bbox="740 577 1063 651">Sometimes the indicator will recommend skipping a gear (3 &gt; 5).</p> <p data-bbox="740 676 1096 791">If there is no gearshift recommendation, then just drive in the appropriate gear for conserving fuel.</p> <p data-bbox="483 850 1036 892">(See, e.g., Exhibits Audi-2 at 27; Audi-3 at 27; Audi-8 at 24).</p>

**Claim 7**

**Corresponding Element in Audi Vehicles**

**Enhanced Shift Indicator**

Applies to vehicles with manual transmission and trip computer with efficiency program.

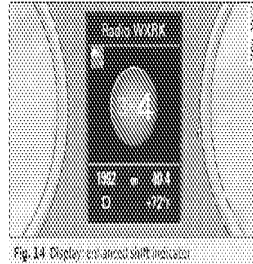

Fig. 14: Display enhanced shift indicator

► In the efficiency program, press the function selection switch → page 26, fig. 11 repeatedly until the enhanced shift indicator appears in the display.

The efficiency program also has an enhanced shift indicator. This enhanced shift indicator follows the same concept as the "standard" shift indicator → page 27. The selected and the recommended gears are highlighted in colors like a traffic light.

The color of the circle indicates if the most suitable gear is engaged or if you should shift up or down.

Green circle without or with a gear	No gear or the most suitable gear is engaged
Yellow circle → fig. 14	Shift up or down one gear
Red circle	Shift up two gears

**More**

This enhanced shift indicator can help you conserve fuel. It is not designed to recommend the correct gear in all driving situations. Only the driver can decide which

(See, e.g., Exhibits Audi-2 at 28; Audi-3 at 28).

**Claim 7**

**Corresponding Element in Audi Vehicles**

Automatic transmission 1

**⚠ WARNING**  
 will gasped, control center overcome physical limitations, so it may not be able to maintain a constant speed under all conditions. Always be ready to apply the brakes.

**⚠ WARNING**  
 applies to vehicles with 8-speed gearbox

Using the manual shift program you can manually select gears.

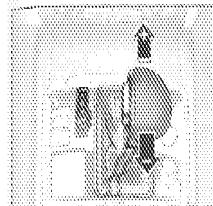

Fig. 129 Selecting manual shift mode

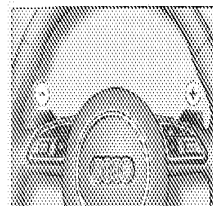

Fig. 130 Kick-down button

**Gear selection with selector lever**

The tiptronic mode can be selected either with the vehicle stationary or on the move.

- ▶ Push the selector lever to the right from D/S. In M appears in the instrument cluster display as soon as the transmission has shifted.
- ▶ To upshift, push the selector lever forward to the plus position (+) = fig. 119.
- ▶ To downshift, push the lever to the minus position (-).

**Gear selection with paddle levers\***

The shift buttons are activated when the selector lever is in D/S or the tiptronic manual shift program.

- ▶ To upshift, touch the button on the right (+) = fig. 120.
- ▶ To downshift, touch the button on the left (-).

The transmission automatically shifts up or down before normal engine speed is reached.

The transmission only allows manual shifting when the engine speed is within the permitted range.

**⚠ WARNING**

- When you shift into the next lower gear, the transmission will downshift only when there is no possibility of over-revving the engine.
- When the kick-down comes on, the transmission will shift down to a lower gear, depending on vehicle and engine speeds.
- Tiptronic is inoperative when the transmission is in the fail-safe mode.

**⚠ WARNING**  
 applies to vehicles with 8-speed gearbox

**Kick-down enables maximum acceleration**

When you depress the accelerator pedal beyond the resistance point, the automatic transmission downshifts into a lower gear, depending on vehicle speed and engine speed. The upshift into the next higher gear takes place once the maximum specified engine speed is reached.

**⚠ WARNING**

Please note that the driver wheels can spin if kick-down is used on a smooth slippery road - there is a risk of skidding.

(See, e.g., Exhibits Audi-1 at 113; Audi-2 at 96; Audi-3 at 86-87; Audi-4 at 89-90; Audi-5 at 111; Audi-6 at 127; Audi-7 at 140-41; Audi-8 at 99-100; Audi-9 at 118; Audi-10 at 89; Audi-11 at 85-

Claim 7	Corresponding Element in Audi Vehicles
<p>7G. said processor subsystem determining, based upon data received from said plurality of sensors, when to activate said fuel overinjection circuit and when to activate said downshift notification circuit.</p>	<p>86; Audi-12 at 84).</p> <p>On information and belief, the accused Audi vehicles include a processor subsystem that determines, based upon data received from said plurality of sensors, when to activate said fuel overinjection circuit and when to activate said downshift notification circuit.</p> <p><i>See, e.g.,</i> citations for elements 1G, 7F.</p>

Claim 8	Corresponding Element in Audi Vehicles
8A. Apparatus for optimizing operation of a vehicle according to claim 7 wherein said processor subsystem further comprises:	<p>The accused Audi vehicles include an apparatus for optimizing operation of a vehicle according to claim 7 wherein said processor subsystem further comprises:</p> <p><i>See, e.g.,</i> citations for claim 1.</p>
8B. means for determining when road speed for said vehicle is increasing;	<p>The accused Audi vehicles include a means for determining when road speed for said vehicle is increasing.</p> <p><i>See, e.g.,</i> citations for claim element 2B.</p>
8C. means for determining when throttle position for said vehicle is increasing; and	<p>The accused Audi vehicles include a means for determining when throttle position for said vehicle is increasing.</p> <p><i>See, e.g.,</i> citations for claim element 2C.</p>
8D. means for comparing manifold pressure to said manifold pressure set point;	<p>The accused Audi vehicles include a means for comparing manifold pressure to said manifold pressure set point.</p> <p><i>See, e.g.,</i> citations for claim element 2D.</p>
8E. said processor subsystem activating said fuel overinjection notification circuit if both road speed and throttle position for said vehicle are increasing and manifold pressure for said vehicle is above said manifold pressure set point.	<p>On information and belief, the accused Audi vehicles include a processor subsystem that activates said fuel overinjection notification circuit if both road speed and throttle position for said vehicle are increasing and manifold pressure for said vehicle is above said manifold pressure set point.</p> <p><i>See, e.g.,</i> citations for claim element 2E.</p>

Claim 10	Corresponding Element in Audi Vehicles
10A. Apparatus for optimizing operation of a vehicle according to claim 7 wherein said processor subsystem further comprises:	The accused Audi vehicles include an apparatus for optimizing operation of a vehicle according to claim 7 wherein said processor subsystem further comprises:  <i>See, e.g.</i> , citations for claim element 1.
10B. means for determining when road speed for said vehicle is decreasing;	The accused Audi vehicles include a means for determining when road speed for said vehicle is decreasing.  <i>See, e.g.</i> , citations for claim element 4B.
10C. means for determining when throttle position for said vehicle is increasing; and	The accused Audi vehicles include a means for determining when throttle position for said vehicle is increasing.  <i>See, e.g.</i> , citations for claim element 2C.
10D. means for determining when manifold pressure for said vehicle is increasing; and	The accused Audi vehicles include a means for determining when manifold pressure for said vehicle is increasing.  <i>See, e.g.</i> , citations for claim element 4D.
10E. means for determining when engine speed for said vehicle is decreasing;	The accused Audi vehicles include a means for determining when engine speed for said vehicle is decreasing.  <i>See, e.g.</i> , citations for claim element 4E.
10F. said processor subsystem activating said	On information and belief, the accused Audi vehicles include a processor subsystem that activates said downshift notification circuit if both road speed and engine speed are decreasing

Claim 10	Corresponding Element in Audi Vehicles
downshift notification circuit if both road speed and engine speed are decreasing and both throttle position and manifold pressure for said vehicle are increasing.	and both throttle position and manifold pressure for said vehicle are increasing.  <i>See, e.g.,</i> citations for claim elements 1G, 7F.

Claim 12	Corresponding Element in Audi Vehicles
12A. Apparatus for optimizing operation of a vehicle according to claim 7 wherein said processor subsystem further comprises:	The accused Audi vehicles include an apparatus for optimizing operation of a vehicle according to claim 7 wherein said processor subsystem further comprises:  <i>See, e.g.</i> , citations for claim 1.
12B. means for determining when road speed for said vehicle is decreasing;	The accused Audi vehicles include a means for determining when road speed for said vehicle is decreasing.  <i>See, e.g.</i> , citations for claim element 4B.
12C. means for determining when throttle position for said vehicle is increasing; and	The accused Audi vehicles include a means for determining when throttle position for said vehicle is increasing.  <i>See, e.g.</i> , citations for claim element 2C.
12D. means for determining when manifold pressure for said vehicle is increasing; and	The accused Audi vehicles include a means for determining when manifold pressure for said vehicle is increasing.  <i>See, e.g.</i> , citations for claim element 4D.
12E. means for determining when engine speed for said vehicle is decreasing;	The accused Audi vehicles include a means for determining when engine speed for said vehicle is decreasing.  <i>See, e.g.</i> , citations for claim element 4E.
12F. said processor subsystem activating said fuel overinjection notification circuit if both	On information and belief, the accused Audi vehicles include a processor subsystem that activates said fuel overinjection notification circuit if both throttle position and manifold pressure for said vehicle are increasing and road speed and engine speed for said vehicle are decreasing.



Claim 12	Corresponding Element in Audi Vehicles
throttle position and manifold pressure for said vehicle are increasing and road speed and engine speed for said vehicle are decreasing.	<i>See, e.g.</i> , citations for claim elements 1E, 1G.

Claim 13	Corresponding Element in Audi Vehicles
13A. Apparatus for optimizing operation of a vehicle, comprising:	The accused Audi vehicles include an apparatus for optimizing operation of a vehicle.  <i>See, e.g.</i> , citations for claim 1.
13B. a plurality of sensors coupled to a vehicle having an engine, said plurality of sensors, which collectively monitor operation of said vehicle, including a road speed sensor, an engine speed sensor, a manifold pressure sensor and a throttle position sensor;	The accused Audi vehicles include a plurality of sensors coupled to the vehicle having an engine, said plurality of sensors, which collectively monitor operation of said vehicle, including a road speed sensor, an engine speed sensor, a manifold pressure sensor and a throttle position sensor  <i>See, e.g.</i> , citations for claim element 1B.
13C. a processor subsystem, coupled to each one of said plurality of sensors, to receive data therefrom;	The accused Audi vehicles include a processor subsystem, coupled to each one of said plurality of sensors, to receive data therefrom.  <i>See, e.g.</i> , citations for claim element 1C.
13D. a memory subsystem, coupled to said processor subsystem, said memory subsystem storing therein a manifold pressure set point, an engine speed set point, and present and prior levels for each one of said plurality of sensors;	The accused Audi vehicles have a memory subsystem, coupled to said processor subsystem, said memory subsystem storing therein a manifold pressure set point, an engine speed set point, and present and prior levels for each one of said plurality of sensors.  <i>See, e.g.</i> , citations for claim element 1D.
13E. a fuel overinjection notification circuit coupled	The accused Audi vehicles include a fuel overinjection notification circuit coupled to said processor subsystem, said fuel overinjection notification circuit issuing a notification that

Claim 13	Corresponding Element in Audi Vehicles
to said processor subsystem, said fuel overinjection notification circuit issuing a notification that excessive fuel is being supplied to said engine of said vehicle;	excessive fuel is being supplied to said engine of said vehicle.  <i>See, e.g.,</i> citations for claim element 1E.
13F. an upshift notification circuit coupled to said processor subsystem, said upshift notification circuit issuing a notification that said engine of said vehicle is being operated at an excessive speed;	The accused Audi vehicles include an upshift notification circuit coupled to said processor subsystem, said upshift notification circuit issuing a notification that said engine of said vehicle is being operated at an excessive speed.  <i>See, e.g.,</i> citations for claim element 1F.
13G. a downshift notification circuit coupled to said processor subsystem, said downshift notification circuit issuing a notification that said engine of said vehicle is being operated at an insufficient engine speed; and	The accused Audi vehicles include a downshift notification circuit coupled to said processor subsystem, said downshift notification circuit issuing a notification that said engine of said vehicle is being operated at an insufficient engine speed; and  <i>See, e.g.,</i> citations for claim element 7F.
13H. said processor subsystem determining, based upon data received from said plurality of sensors, when to activate said fuel overinjection circuit, said upshift	The accused Audi vehicles include a processor subsystem that determines based upon data received from said plurality of sensors, when to activate said fuel overinjection circuit, said upshift notification circuit and said downshift notification circuit.  <i>See, e.g.,</i> citations for claim element 1G.

<b>Claim 13</b>	<b>Corresponding Element in Audi Vehicles</b>
notification circuit and said downshift notification circuit.	

Claim 15	Corresponding Element in Audi Vehicles
15A. Apparatus for optimizing operation of a vehicle according to claim 13 wherein said processor subsystem further comprises:	<p>The accused Audi vehicles include an apparatus for optimizing operation of a vehicle according to claim 13 wherein said processor subsystem further comprises:</p> <p><i>See, e.g.</i>, citations for claim 1.</p>
15B. means for determining when road speed for said vehicle is increasing or decreasing;	<p>The accused Audi vehicles include a means for determining when road speed for said vehicle is increasing or decreasing.</p> <p><i>See, e.g.</i>, citations for claim element 2B.</p> <p>To the extent that 35 U.S.C. §112(6) applies to this claim limitation, the structure(s), act(s), or materials(s) that perform the claimed function of “determining when road speed for said vehicle is increasing or decreasing” are described in, for example, Figures 1 and 2 and associated text of the '781 patent relating to Road Speed Sensor 18, Memory Subsystem 14, and Processor Subsystem 12.</p>
15C. means for determining when throttle position for said vehicle is increasing;	<p>The accused Audi vehicles include a means for determining when throttle position for said vehicle is increasing.</p> <p><i>See, e.g.</i>, citations for claim element 2C.</p>
15D. means for comparing manifold pressure to said manifold pressure set point;	<p>The accused Audi vehicles include a means for comparing manifold pressure to said manifold pressure set point.</p> <p><i>See, e.g.</i>, citations for claim element 2D.</p>
15E. means for comparing engine speed to said RPM set point;	<p>The accused Audi vehicles include a means for comparing engine speed to said RPM set point.</p> <p><i>See, e.g.</i>, citations for claim element 5E.</p>
15F. means for determining	<p>The accused Audi vehicles include a means for determining when manifold pressure is</p>

Claim 15	Corresponding Element in Audi Vehicles
when manifold pressure is increasing;	<p>increasing.</p> <p><i>See, e.g.,</i> citations for claim element 4D.</p>
15G. means for determining when engine speed is increasing or decreasing;	<p>The accused Audi vehicles include a means for determining when engine speed is increasing or decreasing.</p> <p><i>See, e.g.,</i> citations for claim element 4E.</p> <p>To the extent that 35 U.S.C. §112(6) applies to this claim limitation, the structure(s), act(s), or materials(s) that perform the claimed function of “determining when engine speed for said vehicle is increasing or decreasing” are described in, for example, Figures 1 and 2 and associated text of the ’781 patent relating to RPM Sensor 20, Memory Subsystem 14, and Processor Subsystem 12.</p>
15H. said processor subsystem activating said fuel overinjection notification circuit if both road speed and throttle position for said vehicle are increasing and manifold pressure for said vehicle is above said manifold pressure set or if both throttle position and manifold pressure for said vehicle are increasing and road speed and engine speed for said vehicle are decreasing;	<p>On information and belief, the accused Audi vehicles include a processor subsystem that activates said fuel overinjection notification circuit if both road speed and throttle position for said vehicle are increasing and manifold pressure for said vehicle is above said manifold pressure set or if both throttle position and manifold pressure for said vehicle are increasing and road speed and engine speed for said vehicle are decreasing.</p> <p><i>See, e.g.,</i> citations for claim elements 1E, 1G.</p>
15I. said processor	On information and belief, the accused Audi vehicles include a processor subsystem that

Claim 15	Corresponding Element in Audi Vehicles
<p>subsystem activating said upshift notification circuit if both road speed and throttle position for said vehicle are increasing, manifold pressure for said vehicle is at or below said manifold pressure set point and engine speed for said vehicle is at or above said RPM set point; and</p>	<p>activates said upshift notification circuit if both road speed and throttle position for said vehicle are increasing, manifold pressure for said vehicle is at or below said manifold pressure set point and engine speed for said vehicle is at or above said RPM set point.</p> <p><i>See, e.g., citations for claim elements 1F, 1G.</i></p>
<p>15J. said processor subsystem activating said downshift notification circuit if both road speed and engine speed are decreasing and both throttle position and manifold pressure for said vehicle are increasing.</p>	<p>On information and belief, the accused Audi vehicles include a processor subsystem that activates said downshift notification circuit if both road speed and engine speed are decreasing and both throttle position and manifold pressure for said vehicle are increasing.</p> <p><i>See, e.g., citations for claim element 10F.</i></p>

Claim 17	Corresponding Element in Audi Vehicles
<p>17A. Apparatus for optimizing operation of a vehicle, comprising:</p>	<p>The accused Audi vehicles include an apparatus for optimizing operation of a vehicle.</p> <p><i>See, e.g.,</i> citations for claim 1.</p>
<p>17B. a radar detector, said radar detector determining a distance separating a vehicle having an engine and an object in front of said vehicle;</p>	<p>The accused Audi vehicles include a radar detector that determines a distance separating a vehicle having an engine and another object in front of the accused vehicles.</p> <p>For example, the accused Audi vehicles include one or more systems with radar detectors that determine a distance separating a vehicle having an engine and another object in front of the accused vehicles.</p>



**Claim 17**

**Corresponding Element in Audi Vehicles**

**17B1. Audi Adaptive Cruise Control:**

**Audi adaptive cruise control**



Applies to vehicles with Audi adaptive cruise control

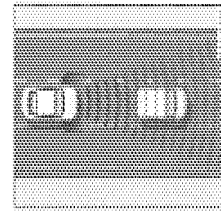

Fig. 89 Detection range

**What can adaptive cruise control do?**

The adaptive cruise control system uses video, radar and ultrasound. Moving vehicles ahead can be recognized up to about 150 feet (300 m) away.

On open roads with no traffic, adaptive cruise control works like a regular cruise control system. The stored speed is maintained. When approaching a moving vehicle detected up ahead, the adaptive cruise control system automatically slows down to match that vehicle's speed and then maintains the distance that the driver previously showed. As soon as the system does not detect a vehicle up ahead, adaptive cruise control accelerates back up to the stored speed.

In stop-and-go traffic, adaptive cruise control can brake until the vehicle stops and accelerate again under certain conditions and if this is possible within the system's limits and capabilities (page 56). Adaptive cruise control will not make an emergency stop.

(See, e.g., Exhibits Audi-1 at 88; Audi-2 at 101; Audi-3 at 92; Audi-4 at 95; Audi-5 at 86; Audi-6 at 109; Audi-7 at 114-15; Audi-9 at 95; Audi-10 at 93).

**Claim 17**

**Corresponding Element in Audi Vehicles**

*Overview*

ACC is also offered as an option for the X32.47. As already introduced for the X31.48, two radar sensors are used in the A7.

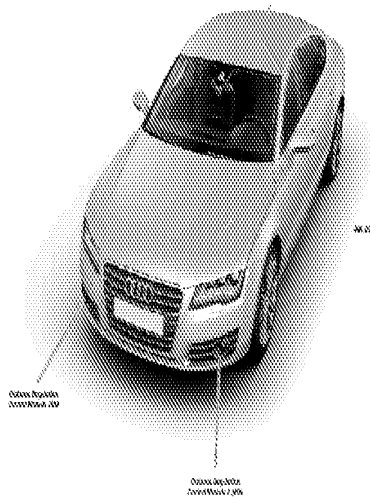

(See Exhibit Audi-18, 2012 A7 Running Gear and Suspension Systems Self-Study Program at 41).

**Claim 17**

**Corresponding Element in Audi Vehicles**

**17B2. Audi Braking Guard:**

**Audi braking guard**



Applies to vehicles with Audi adaptive cruise control.

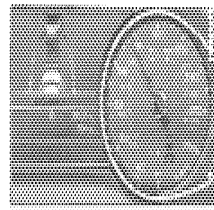

Fig. 97. Instrument cluster approach warning

Braking guard uses radar sensors and a video camera. It also functions within the limits of the system when adaptive cruise control is switched off.

**What can braking guard do?**

When detected in time, the system can assist situations when a vehicle ahead brakes suddenly or if your own vehicle is traveling at a high speed and approaching a vehicle up ahead that is moving more slowly. Braking guard does not react if it cannot detect the situation.

The system advises you of various situations:

- The **distance warning** is given if you are too close to the vehicle ahead for a long time. If the vehicle ahead brakes sharply, you will not be able to avoid a collision. The indicator light in the display comes on.
- The **approach warning** is given when a detected vehicle up ahead in your lane is moving much more slowly than you are or if it brakes sharply. When this warning is given, it may only be possible to avoid a collision by swerving or braking sharply. The indicator light and indicator in the display will warn you about the danger in fig. 97. You will also hear an acoustic signal.

If you do not react fast enough or do not react at all to the situation, braking guard will intervene by braking.

- If a collision is imminent, the system will first provide an acoustic warning by briefly and sharply applying the brakes.
- If you do not react to the acoustic warning, braking guard can brake with increasing force within the limits of the system. This reduces the vehicle speed in the event of a collision.
- The system can initiate maximum braking shortly before a collision.<sup>1)</sup> Full deceleration at high speeds occurs only in vehicles with adaptive cruise control and side assist (pre sense plus).
- If the braking guard senses that you are not braking hard enough when a collision is imminent, it can increase the braking force.
- The pre sense functions also engage when a collision is imminent (page 134).

**Which functions can be controlled?**

You can switch braking guard and the distance/approach warning on or off in the MMI (page 93, Settings in the MMI).

**WARNING**

Lack of attention can cause collisions, other accidents and serious personal injuries. The braking guard is an assist system and cannot prevent a collision by itself. The driver must always intervene. The driver is always responsible for braking at the correct time.

- Always pay close attention to traffic, even when the braking guard is switched on. Be ready to intervene and be ready to take complete control whenever necessary. Always keep the safe and legal distance between your vehicle and vehicles up ahead.
- Braking guard works within limits and will not respond outside the system limits, for example when approaching a

(See, e.g., Exhibits Audi-1 at 92; Audi-2 at 105-06; Audi-3 at 96-97; Audi-4 at 99; Audi-5 at 90;

**Claim 17**

**Corresponding Element in Audi Vehicles**

Audi-6 at 113; Audi-7 at 127; Audi-9 at 99; Audi-10 at 97).

17B3. Audi Side Assist:

**Vehicles left behind**

If you slowly pass a vehicle, the Side Assist has detected the difference in speed between the vehicle and your vehicle is less than 8 mph or 13 km/h, the display in the exterior mirror turns on 30 times as the vehicle enters your blind spot.

The display will not turn on if you quickly pass a vehicle that can enter the detected 105° sensor arc ahead between the vehicle and your vehicle is greater than 8 mph or 13 km/h.

**Functional limitations**

The side sensors are designed to detect the left and right adjacent lanes using the road lines on the adjacent side. In certain situations, the display in the exterior mirror may turn on when a vehicle is in the adjacent lane that is not adjacent to your current lane.

- If the lanes are narrow or if you are driving on the edge of your lane. If this is the case, the system may have detected the vehicle in another lane that is not adjacent to your current lane.
- If you are driving through a curve. The sensor may react to a vehicle that is one lane over from the adjacent lane.
- If side assist reacts to other objects such as sign or obstacles guard rail.
- In poor weather conditions, the side assist functions are limited.

Do not cover the radar sensors of Fig. 105 with stickers, magnets, bicycle bells or other objects, because this will affect the function. Do not use the mirror when towing a trailer. For information on driving, refer to page 213.

**Vehicle that are approaching**

In certain cases, a vehicle will be classified as critical for a lane change when it is in the sensor field for a while. The Side Assist can detect the sensor the display in the exterior mirror will turn on.

**Vehicles traveling with you**

Vehicles traveling with you are indicated in the exterior mirror if they are classified as critical for a lane change. All vehicles detected by Side Assist are indicated by the time they enter your "blind spot" or the future.

**Warnings**

- Always pay attention to traffic and the area around your vehicle. The side assist does not replace a driver's attention. The driver always remains responsible for lane changes and similar driving maneuvers.

(See, e.g., Exhibits Audi-1 at 99; Audi-2 at 110; Audi-3 at 101; Audi-3 at 103; Audi-4 at 103; Audi-5 at 97; Audi-6 at 117; Audi-7 at 130-33; Audi-9 at 106; Audi-10 at 101).

17C. at least one sensor

The accused Audi vehicles include at least one sensor coupled to said vehicle for monitoring

Claim 17	Corresponding Element in Audi Vehicles
<p>coupled to said vehicle for monitoring operation thereof, said at least one sensor including a road speed sensor, a manifold pressure sensor, a throttle position sensor and an engine speed sensor;</p>	<p>operation thereof, said at least one sensor including a road speed sensor, a manifold pressure sensor, a throttle position sensor and an engine speed sensor.</p> <p><i>See, e.g.,</i> citations for claim element 1B.</p>
<p>17D. a processor subsystem, coupled to said radar detector and said at least one sensor, to receive data therefrom;</p>	<p>The accused Audi vehicles include a processor subsystem, coupled to said radar detector and said at least one sensor, to receive data therefrom.</p> <p><i>See, e.g.,</i> citations for claim element 1C.</p>
<p>17E. a memory subsystem, coupled to said processor subsystem, said memory subsystem storing a first vehicle speed/stopping distance table, a manifold pressure set point, an RPM set point, a present level for each one of said at least one sensor and a prior level for each one of said at least one sensor;</p>	<p>The accused Audi vehicles include a memory subsystem, coupled to said processor subsystem, said memory subsystem storing a first vehicle speed/stopping distance table, a manifold pressure set point, an RPM set point, a present level for each one of said at least one sensor and a prior level for each one of said at least one sensor.</p> <p><i>See, e.g.,</i> citations for claim elements 1A-1D.</p> <p>For example, on information and belief, the accused Audi vehicles include one or more systems that use one or more vehicle speed/stopping distance tables stored in one or more memories.</p>



**Claim 17**

**Corresponding Element in Audi Vehicles**

When approaching a moving vehicle up ahead, the adaptive cruise control system automatically brakes to match that object's speed and then maintains the stored distance. If the vehicle ahead accelerates, adaptive cruise control will also accelerate up to the stored speed.

The higher the speed, the greater the distance in yards (meters) is. The **Distance 3** setting is preprogrammed.

The distances provided are specified values. Depending on the driving situation and the how the vehicle ahead is driving, the actual distances may be more or less than these target distances.

The various symbols for the icons in **distance** appear briefly in the information line (page 88, fig. 23) when you change the setting.

Distance 1: This setting corresponds to a distance of 30 feet/9.1 meters when traveling at 62 mph (100 km/h), or a time interval of 1.3 seconds.

Distance 2: This setting corresponds to a distance of 116 feet/35 meters when traveling at 62 mph (100 km/h), or a time interval of 1.3 seconds.

Distance 3: This setting corresponds to a distance of 164 feet/50 meters when traveling at 62 mph (100 km/h), or a time interval of 1.8 seconds.

Distance 4: This setting corresponds to a distance of 216 feet/66 meters when traveling at 62 mph (100 km/h), or a time interval of 2.3 seconds.

**WARNING**

Following other vehicles too closely increases the risk of collisions and serious personal injury.

Setting short distances to the traffic ahead reduces the time and distance available to bring your vehicle to a safe stop and makes it even more necessary to pay close attention to traffic.

Always obey applicable traffic laws, use good judgment, and select a safe following distance for the traffic, road and weather conditions.

**Tip**

- Distance 3 is set automatically each time you switch the ignition on.
- Your standard settings are automatically stored and assigned to the remote control key being used.

(See, e.g., Exhibits Audi-1 at 90-91; Audi-2 at 104; Audi-3 at 95; Audi-4 at 97-98; Audi-5 at 88-89; Audi-6 at 111-12; Audi-7 at 118-20; Audi-9 at 97-98; Audi-10 at 95-96).

**Claim 17**

**Corresponding Element in Audi Vehicles**

**Networking/CAN Data Exchange**

The ACC control module needs approximately 1,700 different signals from other control modules and sensors.

The following overview shows the control modules involved in this data exchange.

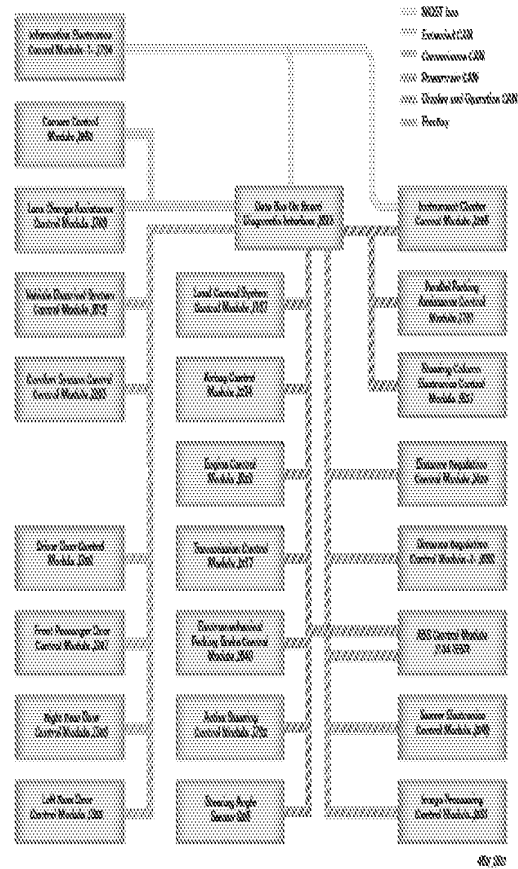

(See, e.g., Exhibit Audi-19, 2011 A8 Running Gear and Suspension Systems Self-Study Program at 50).



**Claim 17**

**Corresponding Element in Audi Vehicles**

**17E2. Audi Braking Guard:**

**Audi braking guard**

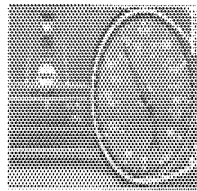



Fig. 97. Instrument cluster approach warning

Braking guard uses radar sensors and a video camera. It also functions within the limits of the system when adaptive cruise control is switched off.

**What can braking guard do?**

When detected in time, the system can assess situations when a vehicle ahead brakes suddenly or if your own vehicle is traveling at a high speed and approaching a vehicle up ahead that is moving more slowly. Braking guard does not react if it cannot detect the situation.

The system advises you of various situations:

- The **distance warning** is given if you are too close to the vehicle ahead for a long time. If the vehicle ahead brakes sharply, you will not be able to avoid a collision. The indicator light  in the display comes on.
- The **approach warning** is given when a detected vehicle is ahead in your lane is moving much more slowly than you are or if it brakes sharply, when this warning is given, it may only be possible to avoid a collision by swerving or braking sharply. The multicolor light  and indicator in the display will warn you about the danger (Fig. 97). You will also hear an acoustic signal.

If you do not react fast enough or do not react at all to the situation, braking guard will intervene by braking.

- If a collision is imminent, the system will first provide an **acoustic warning** by briefly and sharply applying the brakes.
- If you do not react to the acoustic warning, braking guard can brake with increasing force within the limits of the system. This reduces the vehicle speed in the event of a collision.
- The system can initiate maximum braking shortly before a collision<sup>1)</sup>. Full deceleration at high speeds occurs only in vehicles with adaptive cruise control and side assist (lane sense plus).
- If the braking guard senses that you are not braking hard enough when a collision is imminent, it can increase the braking force.
- The pre-crash function also engages when a collision is imminent (page 134).

**Which functions can be controlled?**

You can switch braking guard and the distance/ approach warning on or off in the **MMI** (page 53), **Settings** or the **MMI**.

**ATTENTION**

Lack of attention can cause collisions, other accidents and serious personal injuries. The braking guard is an assist system and cannot prevent a collision by itself. The driver must always intervene. The driver is always responsible for braking at the correct time.

- Always pay close attention to traffic, even when the braking guard is switched on. Be ready to intervene and be ready to take complete control whenever necessary. Always keep the safe and legal distances between your vehicle and vehicles up ahead.
- Braking guard works within limits, and will not intervene outside the system limits. For extreme brake operation, a

(See, e.g., Exhibits Audi-1 at 92; Audi-2 at 105-06; Audi-3 at 96-97; Audi-4 at 99; Audi-5 at 90; Audi-6 at 113; Audi-7 at 127; Audi-9 at 99; Audi-10 at 97).

**Claim 17**

**Corresponding Element in Audi Vehicles**

17E3. Audi Side Assist:

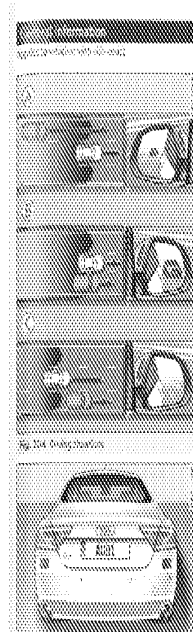

**Vehicles left behind**

If you slowly pass a vehicle that side assist has detected (the difference in speed between the vehicle and your vehicle is less than 5 mph or 15 km/h), the display in the exterior mirror turns on as soon as the vehicle enters your blind spot.

The display will not turn on if you quickly pass a vehicle that side assist has detected (the difference in speed between the vehicle and your vehicle is greater than 8 mph or 15 km/h).

**Functional limitations**

The radar sensors are designed to detect the left and right adjacent lanes, when the road lanes are the normal width. In certain situations, the display in the exterior mirror may turn on even though there are no vehicles located in the area that is critical for a lane change. For example:

- If the lanes are narrow or if you are driving on the edge of your lane. If this is the case, the system may have detected the vehicle in another lane that is not adjacent to your current lane.
- If you are driving through a curve. Side assist may result in a vehicle that is one lane over from the adjacent lane.
- If side assist reacts to other objects such as a sign or displaced guard rail.
- In poor weather conditions. The side assist functions are limited.

Do not cover the radar sensors (Fig. 215) with stickers, tape, etc. because this will affect the function. Do not use side assist when being a trailer. For information on cleaning, refer to page 213.

**WARNING**

- Always pay attention to traffic and to the area around your vehicle. Side assist cannot replace a driver's attention. The driver is always responsible for lane changes and timely driving maneuvers.

**Vehicles that are approaching**

In certain cases, a vehicle will be classified as critical for a lane change even if it is still somewhat far away. The faster a vehicle approaches, the longer the display in the exterior mirror will turn on.

**Vehicles traveling with you**

Vehicles traveling with you are indicated in the exterior mirror if they are classified as critical for a lane change. All vehicles detected by side assist are indicated by the time they enter your "blind spot" or the lane.

**Fig. 214: Driving situation**

**Fig. 215: View in the vehicle mirror of the sensor**

Side assist functions at speeds above approximately 20 mph (30 km/h).

(See, e.g., Exhibits Audi-1 at 99; Audi-2 at 110; Audi-3 at 101; Audi-4 at 103; Audi-5 at 97; Audi-6 at 117; Audi-7 at 130-34; Audi-9 at 106; Audi-10 at 101).

Claim 17	Corresponding Element in Audi Vehicles
	<p>On information and belief, additional vehicle systems, including but not limited to electronic brake control systems (<i>e.g.</i>, ABS, TCS, BAS, ESC, <i>etc.</i>) and speed control systems (<i>e.g.</i>, electronic speed control (ESC) systems) included in the accused Audi vehicles, and safety and performance testing systems use vehicle speed/stopping distance tables stored in memory.</p>
<p>17F. a vehicle proximity alarm circuit coupled to said processor subsystem, said vehicle proximity alarm circuit issuing an alarm that said vehicle is too close to an object;</p>	<p>The accused Audi vehicles include a vehicle proximity alarm circuit coupled to said processor subsystem, said vehicle proximity alarm circuit issuing an alarm that said vehicle is too close to an object.</p> <p>For example, the accused Audi vehicles include one or more systems that include circuits that issue an alarm to indicate that the vehicle is too close to an object.</p>

**Claim 17**

**Corresponding Element in Audi Vehicles**

**17F1. Audi Adaptive Cruise Control:**

**Indicator lights**

**Adaptive cruise control is switched on:** No vehicles are detected up ahead. The entered speed is maintained.

**A moving vehicle is detected up ahead:** The adaptive cruise control system regulates the speed and distance to the moving vehicle ahead and accelerates/brakes automatically.

**Adaptive cruise control is switched on:** A moving vehicle up ahead was detected. Your vehicle remains stopped.

**When automatic braking is not able to keep enough distance to a previously detected moving vehicle up ahead, you must take control and brake:** Prompt for driver intervention.

**Display**

If adaptive cruise control is not shown in the display, you can call it up with the multifunction steering wheel buttons.

Based on the symbols in the display, you can determine if the system is maintaining a distance to the vehicle ahead and what that distance is.

**No vehicle** - No vehicle ahead was detected.

**White vehicle** - A vehicle ahead was detected.

**Red vehicle** - Prompt for the driver to take action.

**Both arrows on the scale** indicate the distance to the vehicle ahead. No arrow appears when the vehicle is on an open road and there is no object ahead. If an object is detected ahead, the arrow moves on the scale.

(See, e.g., Exhibits Audi-1 at 89; Audi-2 at 102; Audi-3 at 93; Audi-4 at 96; Audi-5 at 87; Audi-6

Claim 17	Corresponding Element in Audi Vehicles
	<p>at 110; Audi-7 at 120-22; Audi-9 at 96; Audi-10 at 94).</p> <p><i>Audi pre sense front (vehicles with adaptive cruise control)</i></p> <p><i>Audi pre sense front includes the functions in Audi pre sense basic. In addition, within the limits of the system, the likelihood of a collision with the vehicle immediately ahead is also calculated. If the system senses an imminent collision the following functions can be triggered:</i></p> <ul style="list-style-type: none"> <li>- Braking guard → page 92</li> <li>- Tightening the safety belts</li> <li>- Closing the windows and the sunroof (leaving a small open gap)</li> </ul> <p>(See, e.g., Exhibits Audi-1 at 194; Audi-5 at 192; Audi-6 at 110; Audi-9 at 196).</p>

**Claim 17**

**Corresponding Element in Audi Vehicles**

**17F2. Audi Braking Guard:**

**Audi braking guard**

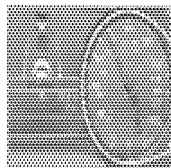



The Audi instrument cluster displays the Braking Guard indicator.

Braking guard uses radar sensors and a wide camera. It also functions within the limits of the system when adaptive cruise control is active.

**What can braking guard do?**

When data that is close, the system can assess situations when a vehicle ahead brakes suddenly or if your own vehicle is traveling at a high speed and approaching a vehicle at a close distance moving more slowly. Braking guard does not react if it cannot detect the situation.

The system advises you of various situations:

- The **distance warning** is given if you are too close to the vehicle ahead for a long time. If the vehicle slows down suddenly, you will not be able to avoid a collision. The indicator light  in the display comes on.
- The **approach warning** is given when a detected vehicle is ahead in your lane: moving more slowly than you are or if it brakes abruptly. When this warning is given, it may only be possible to avoid a collision by slowing or braking abruptly. The indicator light  and indicator in the display will warn you about the danger (Fig. 57). You will also hear an acoustic signal.

If you do not react fast enough or do not react at all to the situation, braking guard will intervene by braking.

- If a collision is imminent, the system will first provide an acute warning by briefly and strongly applying the brakes.
- If you do not react to the acute warning, braking guard will brake with increasing force within the limits of the system. This reduces the vehicle speed in the event of a collision.
- The system can initiate maximum braking (stronger than a collision). It will do so even at high speeds only in vehicles with adaptive brake control and ABS with ESP (see Brake Plus).
- If the braking guard senses that you are not braking fast enough when a collision is imminent, it can increase the braking force.
- The pre-collision function also engages when a collision is imminent (page 124).

**Which functions can be controlled?**

You can control braking guard and the distance approach warning on in off in the MMI (page 81). See page 81.



- Lack of attention can cause collisions, with or without, and serious personal injuries. The braking guard is an assist system and cannot prevent a collision by itself. The driver must always observe the driver's block responsible for braking of the car in front.
- Always pay close attention to traffic, even when the braking guard is activated. Be ready to intervene and be ready to take complete control whenever necessary. Always keep the safe and legal distance between your vehicle and vehicles in front.
- Braking guard works within limits and will not intervene outside the system's limits. For example when approaching a

(See, e.g., Exhibits Audi-1 at 92; Audi-2 at 105-06; Audi-3 at 96-97; Audi-4 at 99; Audi-5 at 90; Audi-6 at 113; Audi-7 at 127; Audi-9 at 99; Audi-10 at 97).

Claim 17	Corresponding Element in Audi Vehicles
	<p><i>Audi pre sense front (vehicles with adaptive cruise control*)</i></p> <p><i>Audi pre sense front includes the functions in Audi pre sense basic. In addition, within the limits of the system, the likelihood of a collision with the vehicle immediately ahead is also calculated. If the system senses an imminent collision the following functions can be triggered:</i></p> <ul style="list-style-type: none"> <li>- Braking guard → page 52</li> <li>- Tightening the safety belts</li> <li>- Closing the windows and the sunroof* (leaving a small open gap)</li> </ul> <p>(See, e.g., Exhibits Audi-1 at 194; Audi-5 at 192; Audi-9 at 196).</p> <p>17F3. Audi Side Assist:</p> <p><i>Warning stage</i></p> <p><i>If you activate the turn signal, side assist warns you about vehicles that are detected and classified as critical. The display in the respective mirror blinks brightly. If this happens, check traffic by glancing in the rearview mirror and over your shoulder → Δ in General information on page 55.</i></p> <div style="border: 1px solid black; padding: 5px; margin-top: 10px;"> <p><b>Tip</b></p> <ul style="list-style-type: none"> <li>- You can adjust the brightness of the display → page 100.</li> <li>- Please refer to the instructions for towing a trailer located in → page 58.</li> </ul> </div> <p>(See, e.g., Exhibits Audi-1 at 98; Audi-2 at 109; Audi-3 at 100; Audi-4 at 102; Audi-5 at 96; Audi-6 at 116; Audi-7 at 130-34; Audi-9 at 105; Audi-10 at 100).</p>

Claim 17	Corresponding Element in Audi Vehicles
	<p data-bbox="748 432 1073 495">Audi pre sense rear (vehicles with Audi side assist*)</p> <p data-bbox="748 527 1089 674">Audi pre sense rear includes the functions in Audi pre sense basic. In addition, the likelihood of a rear-end collision with the vehicle coming from behind is also calculated. If the</p> <p data-bbox="748 726 1065 789">risk of a collision is detected, the following functions can be triggered:</p> <ul data-bbox="748 821 1089 926" style="list-style-type: none"> <li>- Tightening the safety belts</li> <li>- Closing the windows and the sunroof* (leaving a small open gap)</li> </ul> <p data-bbox="483 999 1065 1031">(See, e.g., Exhibits Audi-1 at 194; Audi-5 at 192; Audi-9 at 196).</p>
<p data-bbox="204 1045 440 1367">17G. a fuel overinjection circuit coupled to said processor subsystem, said fuel overinjection circuit issuing a notification that excessive fuel is being supplied to said engine of said vehicle;</p>	<p data-bbox="483 1045 1292 1157">The accused Audi vehicles include a fuel overinjection circuit coupled to said processor subsystem, said fuel overinjection circuit issuing a notification that excessive fuel is being supplied to said engine of said vehicle.</p> <p data-bbox="483 1209 846 1241"><i>See, e.g.,</i> citations for claim element 1E.</p>
<p data-bbox="204 1388 464 1667">17H. an upshift notification circuit coupled to said processor subsystem, said upshift notification circuit issuing a notification that said engine of said vehicle is being operated at an</p>	<p data-bbox="483 1388 1357 1499">The accused Audi vehicles include an upshift notification circuit coupled to said processor subsystem, said upshift notification circuit issuing a notification that said engine of said vehicle is being operated at an excessive speed.</p> <p data-bbox="483 1556 846 1587"><i>See, e.g.,</i> citations for claim element 1F.</p>



Claim 17	Corresponding Element in Audi Vehicles
excessive speed;	
<p>17I. said processor subsystem determining, based upon data received from said radar detector, said at least one sensor and said memory subsystem, when to activate said vehicle proximity alarm circuit, when to activate said fuel overinjection circuit, and when to activate said upshift notification circuit.</p>	<p>On information and belief, the accused Audi vehicles include a processor subsystem determining, based upon data received from said radar detector, said at least one sensor and said memory subsystem, when to activate said vehicle proximity alarm circuit, when to activate said fuel overinjection circuit, and when to activate said upshift notification circuit.</p> <p><i>See, e.g.</i>, citations for claim elements 1G, 17F.</p>

Claim 18	Corresponding Element in Audi Vehicles
<p>18A. Apparatus for optimizing operation of a vehicle according to claim 17 wherein:</p>	<p>The accused Audi vehicles include an apparatus for optimizing operation of a vehicle according to claim 17.</p> <p><i>See, e.g.,</i> citations for claim 17.</p>
<p>18B. said at least one sensor further includes a windshield wiper sensor for indicating whether a windshield wiper of said vehicle is activated; and</p>	<p>The accused Audi vehicles include at least one sensor further including a windshield wiper sensor for indicating whether a windshield wiper of said vehicle is activated.</p> <p>For example, the accused Audi vehicles include a windshield wiper sensor that determines when the wipers are turned on.</p>

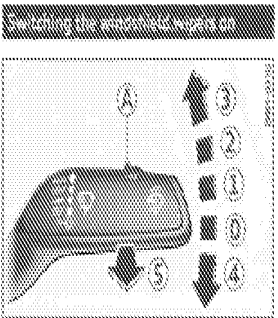



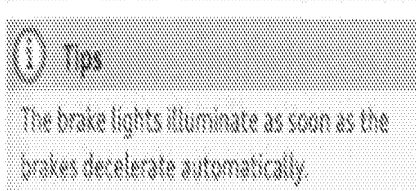

Claim 18	Corresponding Element in Audi Vehicles
	<p data-bbox="820 430 1031 499"><b>Wiper and washer system</b></p>  <p data-bbox="820 835 974 861">Fig. 42 Windshield wiper lever</p> <p data-bbox="820 892 1079 945">Move the windshield wiper lever to the corresponding position:</p> <ul data-bbox="820 955 1079 1375" style="list-style-type: none"> <li data-bbox="820 955 974 987">⓪ - Windshield wipers off</li> <li data-bbox="820 997 1079 1375">Ⓛ - Rain sensor mode. The windshield wipers switch on once the vehicle speed exceeds approximately 2 mph (4 km/h) and it is raining. The higher the rain sensor sensitivity is set (switch Ⓛ to the right), the earlier the windshield wipers react to moisture on the windshield. You can deactivate rain sensor mode in the MMI, which will then activate intermittent mode. Select: <b>MMI</b> function button &gt; <b>Car1*</b> systems control button &gt; <b>Driver assist</b> &gt; <b>Rain sensor</b> &gt; <b>Off</b>. In intermittent mode, you can adjust the interval time using the switch Ⓜ.</li> </ul> <p data-bbox="483 1428 1307 1501">(See, e.g., Exhibits Audi-1 at 48; Audi-2 at 53-54; Audi-3 at 49; Audi-4 at 56; Audi-5 at 48; Audi-6 at 54; Audi-7 at 63-64; Audi-9 at 52; Audi-10 at 49).</p>
18C. said memory subsystem further storing a second vehicle speed/stopping distance	<p data-bbox="483 1512 1282 1596">The accused Audi vehicles include a memory subsystem further storing a second vehicle speed/stopping distance table.</p> <p data-bbox="483 1638 1307 1680">On information and belief, the accused Audi vehicles store a second vehicle speed/stopping</p>

<b>Claim 18</b>	<b>Corresponding Element in Audi Vehicles</b>
table.	distance table.  <i>See, e.g.,</i> citations for claim element 17E.

<b>Claim 19</b>	<b>Corresponding Element in Audi Vehicles</b>
19A. Apparatus for optimizing operation of a vehicle according to claim 17 and further comprising:	The accused Audi vehicles include an apparatus for optimizing operation of a vehicle according to claim 17.  <i>See, e.g.,</i> citations for claim 17.
19B. a throttle controller for controlling a throttle of said engine of said vehicle; and	The accused Audi vehicles include a throttle controller for controlling a throttle of said engine of said vehicle.  <i>See, e.g.,</i> citations for claim element 1B.
19C. said processor subsystem selectively reducing said throttle based upon data received from said radar detector, said at least one sensor and said memory subsystem.	On information and belief, the accused Audi vehicles include a processor subsystem that selectively reduces said throttle based upon data received from said radar detector, said at least one sensor and said memory subsystem.  <i>See, e.g.,</i> citations for claim element 1G and 17E1.

Claim 20	Corresponding Element in Audi Vehicles
<p>20. Apparatus for optimizing operation of a vehicle according to claim 19 wherein said at least one sensor further includes a brake sensor for indicating whether a brake system of said vehicle is activated.</p>	<p>The accused Audi vehicles include an apparatus for optimizing operation of a vehicle according to claim 19 wherein said at least one sensor further includes a brake sensor for indicating whether a brake system of said vehicle is activated.</p> <p>For example, the accused Audi vehicles include a brake sensor that determines when the brake system is activated (e.g., as indicated by brake lights.)</p>  <p>(See, e.g., Exhibits Audi-1 at 85; Audi-2 at 89; Audi-3 at 80; Audi-4 at 83; Audi-5 at 83; Audi-6 at 95; Audi-9 at 91; Audi-10 at 83).</p>

Claim 21	Corresponding Element in Audi Vehicles
21A. Apparatus for optimizing operation of a vehicle according to claim 19 wherein said processor subsystem further comprises:	The accused Audi vehicles include an apparatus for optimizing operation of a vehicle according to claim 19 wherein said processor subsystem further comprises:  <i>See, e.g.,</i> citations for claims 1, 19.
21B. means for counting a total number of vehicle proximity alarms determined by said processor subsystem;	The accused Audi vehicles include a means for counting a total number of vehicle proximity alarms determined by said processor subsystem.

Claim 21	Corresponding Element in Audi Vehicles
	<p>21B1. Audi Adaptive Cruise Control:</p> <p> <b>Indicator lights</b></p> <ul style="list-style-type: none"> <li> - Adaptive cruise control is switched on. No vehicles are detected up ahead. The stored speed is maintained.</li> <li> - A moving vehicle is detected up ahead. The adaptive cruise control system regulates the speed and distance to the moving vehicle ahead and accelerates/brakes automatically.</li> <li> - Adaptive cruise control is switched on. A moving vehicle up ahead was detected. Your vehicle remains stopped.</li> <li> - When automatic braking is not able to keep enough distance to a previously detected moving vehicle up ahead, you must take control and brake <i>→ page 92, Prompt for driver intervention.</i></li> </ul> <p> <b>Display</b></p> <p>If adaptive cruise control is not shown in the display, you can call it up with the multifunction steering wheel buttons <i>→ page 24.</i></p> <p>Based on the symbols in the display, you can determine if the system is maintaining a distance to the vehicle ahead and what that distance is.</p> <ul style="list-style-type: none"> <li><b>No vehicle</b> - No vehicle ahead was detected.</li> <li><b>White vehicle</b> - A vehicle ahead was detected.</li> <li><b>Red vehicle</b> - Prompt for the driver to take action <i>→ page 92.</i></li> </ul> <p>Both arrows on the scale  indicate the distance to the vehicle ahead. No arrow appears when the vehicle is on an open road and there is no object ahead. If an object is detected ahead, the arrow moves on the scale.</p>

Claim 21	Corresponding Element in Audi Vehicles
	<p>(See, e.g., Exhibits Audi-1 at 89; Audi-2 at 102; Audi-3 at 93; Audi-4 at 96; Audi-5 at 87; Audi-6 at 110; Audi-7 at 120-22; Audi-9 at 96; Audi-10 at 94).</p> <p style="text-align: center;">Audi pre sense front (vehicles with adaptive cruise control*)</p> <p style="text-align: center;">Audi pre sense front includes the functions in Audi pre sense basic. In addition, within the limits of the system, the likelihood of a collision with the vehicle immediately ahead is also calculated. If the system senses an imminent collision the following functions can be triggered:</p> <ul style="list-style-type: none"> <li>-- Braking guard *page 92</li> <li>-- Tightening the safety belts</li> <li>-- Closing the windows and the sunroof* (leaving a small open gap)</li> </ul> <p>(See, e.g., Exhibits Audi-1 at 194; Audi-5 at 192; Audi-6 at 110; Audi-9 at 196).</p>



Claim 21

Corresponding Element in Audi Vehicles

21B2. Audi Braking Guard:

Audi braking guard



Applies to vehicles with full adaptive cruise control

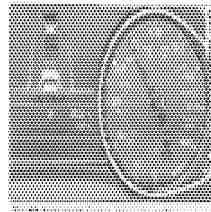

Fig. 80 Instrument cluster adaptive braking

Braking guard uses radar sensors and a video camera. It also functions within the limits of the system when adaptive cruise control is switched off.

What can braking guard do?

When detected in time, the system can assist situations when a vehicle ahead brakes suddenly or if your own vehicle is traveling at a high speed and approaching a vehicle up ahead that is moving more slowly. Braking guard does not react if it cannot detect the situation.

The system advises you of various situations:

- The **distance warning** is given if you are too close to the vehicle ahead for a long time. If the vehicle ahead brakes sharply, you will not be able to avoid a collision. The indicator light in the display comes on.
- The **approach warning** is given when a detected vehicle up ahead in your lane is moving much more slowly than you are or if it brakes sharply. When this warning is given, it may only be possible to avoid a collision by swerving or braking sharply. The indicator light and indicator in the display will warn you about the danger in fig. 81. You will also hear an acoustic signal.

If you do not react fast enough or do not react at all to the situation, braking guard will intervene by braking.

- If a collision is imminent, the system will first provide an **across warning** by briefly and sharply applying the brakes.
- If you do not react to the across warning, braking guard can brake with increasing force within the limits of the system. This reduces the vehicle speed in the event of a collision.
- The system can initiate maximum braking shortly before a collision<sup>1)</sup>. Full deceleration at high speeds occurs only in vehicles with electronic cross control and side assist (pre sense plus).
- If the braking guard senses that you intend braking too strongly when a collision is imminent, it can increase the braking force.
- The pre sense functions also engage when a collision is imminent (page 129).

Which functions can be controlled?

You can switch braking guard and the distance approach warning on or off in the MMI (page 83, Settings in the MMI).



Lack of attention can cause collisions, other accidents and serious personal injuries. The braking guard is an assist system and cannot prevent a collision by itself. The driver must always intervene. The driver is always responsible for braking at the correct time.

Always pay close attention to traffic, even when the braking guard is switched on. Be ready to intervene and be ready to take complete control whenever necessary. Always keep the safe and legal distance between your vehicle and vehicles up ahead.

Braking guard works within limits and will not respond outside the system limits. For example, when approaching a

(See, e.g., Exhibits Audi-1 at 92; Audi-2 at 105-06; Audi-3 at 96-97; Audi-4 at 99; Audi-5 at 90;

Claim 21	Corresponding Element in Audi Vehicles
	<p data-bbox="483 428 1019 464">Audi-6 at 113; Audi-7 at 127; Audi-9 at 99; Audi-10 at 97).</p> <p data-bbox="769 525 1024 583"><b>Audi pre sense front (vehicles with adaptive cruise control*)</b></p> <p data-bbox="769 604 1073 840">Audi pre sense front includes the functions in Audi pre sense basic. In addition, within the limits of the system, the likelihood of a collision with the vehicle immediately ahead is also calculated. If the system senses an imminent collision the following functions can be triggered:</p> <ul data-bbox="769 863 1073 999" style="list-style-type: none"> <li>- Braking guard → page 92</li> <li>- Tightening the safety belts</li> <li>- Closing the windows and the sunroof* (leaving a small open gap)</li> </ul> <p data-bbox="483 1062 1203 1098">(See, e.g., Exhibits Audi-1 at 194; Audi-5 at 192; Audi-6 at 110; Audi-9 at 196).</p> <p data-bbox="483 1148 703 1184">21B3. Audi Side Assist:</p> <p data-bbox="781 1247 883 1274"><b>Warning stage</b></p> <p data-bbox="781 1289 1057 1503">If you activate the turn signal, side assist warns you about vehicles that are detected and classified as critical. The display in the respective mirror blinks brightly. If this happens, check traffic by glancing in the rearview mirror and over your shoulder →  in General information on page 93.</p> <div data-bbox="781 1520 1057 1696" style="border: 1px solid black; padding: 5px;"> <p data-bbox="789 1528 850 1558"><b>Tip</b></p> <ul data-bbox="802 1577 1040 1696" style="list-style-type: none"> <li>- You can adjust the brightness of the display → page 100.</li> <li>- Please refer to the instructions for towing a trailer located in → page 93.</li> </ul> </div>

Claim 21	Corresponding Element in Audi Vehicles
	<p>(See, e.g., Exhibits Audi-1 at 98; Audi-2 at 109; Audi-3 at 100; Audi-4 at 102; Audi-5 at 96; Audi-6 at 116; Audi-7 at 130-34; Audi-9 at 105; Audi-10 at 100).</p> <p style="text-align: center;"><b>Audi pre sense rear (vehicles with Audi side assist*)</b></p> <p style="text-align: center;">Audi pre sense rear includes the functions in Audi pre sense basic. In addition, the likelihood of a rear-end collision with the vehicle coming from behind is also calculated. If the risk of a collision is detected, the following functions can be triggered:</p> <ul style="list-style-type: none"> <li>- Tightening the safety belts</li> <li>- Closing the windows and the sunroof* (leaving a small open gap)</li> </ul> <p>(See, e.g., Exhibits Audi-1 at 194; Audi-5 at 192; Audi-9 at 196).</p> <p>To the extent that 35 U.S.C. §112(6) applies to this claim limitation, the structure(s), act(s), or materials(s) that perform the claimed function of “counting a total number of vehicle proximity alarms determined by said processor subsystem” are described in, for example, Figures 1 and 2 and associated text relating to the expression programmed in the Processor Subsystem 12.</p>
<p>21C. means for selectively reducing said throttle based upon said total number of vehicle proximity alarms.</p>	<p>On information and belief, the accused Audi vehicles include a means for selectively reducing said throttle based upon said total number of vehicle proximity alarms.</p> <p>See, e.g., citations for claim element 21B.</p> <p>To the extent that 35 U.S.C. §112(6) applies to this claim limitation, the structure(s), act(s), or materials(s) that perform the claimed function of “counting a total number of vehicle proximity</p>

Claim 21	Corresponding Element in Audi Vehicles
	alarms determined by said processor subsystem” are described in, for example, Figures 1 and 2 and associated text relating to the expression programmed in the Processor Subsystem 12.

Claim 22	Corresponding Element in Audi Vehicles
22A. Apparatus for optimizing operation of a vehicle according to claim 17 and further comprising:	The accused Audi vehicles include an apparatus for optimizing operation of a vehicle according to claim 17 and further comprising:  <i>See, e.g.,</i> citations for claim 17.
22B. a downshift notification circuit coupled to said processor subsystem, said downshift notification circuit issuing a notification that said engine of said vehicle is being operated at an insufficient engine speed; and	The accused Audi vehicles include a downshift notification circuit coupled to said processor subsystem, said downshift notification circuit issuing a notification that said engine of said vehicle is being operated at an insufficient engine speed.  <i>See, e.g.,</i> citations for claim element 7F.
22C. said processor subsystem determining, based upon data received from said plurality of sensors, when to activate said downshift notification circuit.	The accused Audi vehicles include a processor subsystem that determines, based upon data received from said plurality of sensors, when to activate said downshift notification circuit.  <i>See, e.g.,</i> citations for claim elements 1B, 1G.

Claim 23	Corresponding Element in Audi Vehicles
23A. Apparatus for optimizing operation of a vehicle, comprising:	The accused Audi vehicles include an apparatus for optimizing operation of a vehicle. <i>See, e.g.,</i> citations for claims 1, 17.
23B. a radar detector, said radar detector determining a distance separating a vehicle having an engine and an object in front of said vehicle;	The accused Audi vehicles include a radar detector that determines a distance separating a vehicle having an engine and another object in front of the accused vehicles. <i>See, e.g.,</i> citations for claim element 17B.
23C. a plurality of sensors coupled to a vehicle having an engine, said plurality of sensors, which collectively monitor operation of said vehicle, including a road speed sensor, and engine speed sensor, a manifold pressure sensor and a throttle position sensor;	The accused Audi vehicles include a plurality of sensors coupled to a vehicle having an engine, said plurality of sensors, which collectively monitor operation of said vehicle, including a road speed sensor, and engine speed sensor, a manifold pressure sensor and a throttle position sensor <i>See, e.g.,</i> citations for claim element 1B.
23D. a processor subsystem, coupled to said radar detector and each one of said plurality of sensors, to receive data therefrom;	The accused Audi vehicles include a processor subsystem, coupled to said radar detector and each one of said plurality of sensors, to receive data therefrom; <i>See, e.g.,</i> citations for claim element 1C.
23E. a memory subsystem, coupled to said processor subsystem, said memory subsystem storing therein a first vehicle speed/stopping distance table, a manifold	The accused Audi vehicles include a memory subsystem, coupled to said processor subsystem, said memory subsystem storing therein a first vehicle speed/stopping distance table, a manifold pressure set point, an RPM set point, and present and prior levels for each one of said plurality of sensors.

Claim 23	Corresponding Element in Audi Vehicles
pressure set point, an RPM set point, and present and prior levels for each one of said plurality of sensors;	<i>See, e.g.</i> , citations for claim element 17E.
23F. a fuel overinjection notification circuit coupled to said processor subsystem, said fuel overinjection notification circuit issuing a notification that excessive fuel is being supplied to said engine of said vehicle;	<p>The accused Audi vehicles include a fuel overinjection notification circuit coupled to said processor subsystem, said fuel overinjection notification circuit issuing a notification that excessive fuel is being supplied to said engine of said vehicle.</p> <p><i>See, e.g.</i>, citations for claim element 1E.</p>
23G. an upshift notification circuit coupled to said processor subsystem, said upshift notification circuit issuing a notification that said engine of said vehicle is being operated at an excessive speed;	<p>The accused Audi vehicles include an upshift notification circuit coupled to said processor subsystem, said upshift notification circuit issuing a notification that said engine of said vehicle is being operated at an excessive speed.</p> <p><i>See, e.g.</i>, citations for claim element 1F.</p>
23H. said processor subsystem determining, based upon data received from said plurality of sensors, when to activate said fuel overinjection circuit and when to activate said upshift notification circuit;	<p>The accused Audi vehicles include a processor subsystem that determines, based upon data received from said plurality of sensors, when to activate said fuel overinjection circuit and when to activate said upshift notification circuit.</p> <p><i>See, e.g.</i>, citations for claim element 1G.</p>
23I. a vehicle proximity	The accused Audi vehicles include a vehicle proximity alarm circuit coupled to said processor

Claim 23	Corresponding Element in Audi Vehicles
<p>alarm circuit coupled to said processor subsystem, said vehicle proximity alarm circuit issuing an alarm that said vehicle is too close to said object;</p>	<p>subsystem, said vehicle proximity alarm circuit issuing an alarm that said vehicle is too close to said object.</p> <p><i>See, e.g.,</i> citations for claim 17F.</p>
<p>23J. said processor subsystem determining, based upon data received from said radar detector, said at least one sensor and said memory subsystem, when to activate said vehicle proximity alarm circuit.</p>	<p>The accused Audi vehicles includes a processor subsystem that determines, based upon data received from said radar detector, said at least one sensor and said memory subsystem, when to activate said vehicle proximity alarm circuit.</p> <p><i>See, e.g.,</i> citations for claim element 17I.</p>

Claim 24	Corresponding Element in Audi Vehicles
24A. Apparatus for optimizing operation of a vehicle according to claim 23 wherein said processor subsystem further comprises:	<p>The accused Audi vehicles include an apparatus for optimizing operation of a vehicle according to claim 23 wherein said processor subsystem further comprises:</p> <p><i>See, e.g.</i>, citations for claim 23.</p>
24B. means for determining when road speed for said vehicle is increasing or decreasing;	<p>The accused Audi vehicles include a means for determining when road speed for said vehicle is increasing or decreasing.</p> <p><i>See, e.g.</i>, citations for claim element 15B.</p>
24C. means for determining when throttle position for said vehicle is increasing or decreasing; and	<p>The accused Audi vehicles include a means for determining when throttle position for said vehicle is increasing or decreasing.</p> <p><i>See, e.g.</i>, citations for claim element 2C.</p> <p>To the extent that 35 U.S.C. §112(6) applies to this claim limitation, the structure(s), act(s), or materials(s) that perform the claimed function of “determining when throttle position for said vehicle is increasing or decreasing” are described in, for example, Figures 1 and 2 and associated text of the '781 patent relating to Throttle Sensor 24, Memory Subsystem 14, and Processor Subsystem 12.</p>
24D. means for comparing manifold pressure to said manifold pressure set point;	<p>The accused Audi vehicles include a means for comparing manifold pressure to said manifold pressure set point.</p> <p><i>See, e.g.</i>, citations for claim element 2D.</p>
24E. means for determining when manifold pressure for said vehicle is increasing or decreasing; and	<p>The accused Audi vehicles include a means for determining when manifold pressure for said vehicle is increasing or decreasing.</p> <p><i>See, e.g.</i>, citations for claim element 4D.</p>



Claim 24	Corresponding Element in Audi Vehicles
	To the extent that 35 U.S.C. §112(6) applies to this claim limitation, the structure(s), act(s), or materials(s) that perform the claimed function of “determining when manifold pressure for said vehicle is increasing or decreasing” are described in, for example, Figures 1 and 2 and associated text of the '781 patent relating to Manifold PSI Sensor 22, Memory Subsystem 14, and Processor Subsystem 12.
24F. means for determining when engine speed for said vehicle is increasing or decreasing;	The accused Audi vehicles include a means for determining when engine speed for said vehicle is increasing or decreasing.  <i>See, e.g.,</i> citations for claim element 15G.
24G. said processor subsystem activating said fuel overinjection notification circuit if both road speed and throttle position for said vehicle are increasing and manifold pressure for said vehicle is above said manifold pressure set point or if both throttle position and manifold pressure for said vehicle are increasing and road speed and engine speed for said vehicle are decreasing.	On information and belief, the accused Audi vehicles include a processor subsystem that activates said fuel overinjection notification circuit if both road speed and throttle position for said vehicle are increasing and manifold pressure for said vehicle is above said manifold pressure set point or if both throttle position and manifold pressure for said vehicle are increasing and road speed and engine speed for said vehicle are decreasing.  <i>See, e.g.,</i> citations for claim element 1G.

Claim 25	Corresponding Element in Audi Vehicles
25A. Apparatus for optimizing operation of a vehicle according to claim 23 wherein said processor subsystem further comprises:	The accused Audi vehicles include an apparatus for optimizing operation of a vehicle according to claim 23 wherein said processor subsystem further comprises:  <i>See, e.g.,</i> citations for claim 23.
25B. means for determining when road speed for said vehicle is increasing;	The accused Audi vehicles include a means for determining when road speed for said vehicle is increasing.  <i>See, e.g.,</i> citations for claim element 2B.
25C. means for determining when throttle position for said vehicle is increasing; and	The accused Audi vehicles include a means for determining when throttle position for said vehicle is increasing.  <i>See, e.g.,</i> citations for claim element 2C.
25D. means for comparing manifold pressure to said manifold pressure set point;	The accused Audi vehicles include a means for comparing manifold pressure to said manifold pressure set point.  <i>See, e.g.,</i> citations for claim element 2D.
25E. means for comparing engine speed to said RPM set point;	The accused Audi vehicles include a means for comparing engine speed to said RPM set point.  <i>See, e.g.,</i> citations for claim element 5E.
25F. said processor subsystem activating said upshift notification circuit if both road speed and throttle position for said vehicle are increasing, manifold pressure for said vehicle is	On information and belief, the accused Audi vehicles include a processor subsystem that activates said upshift notification circuit if both road speed and throttle position for said vehicle are increasing, manifold pressure for said vehicle is at or below said manifold pressure set point and engine speed for said vehicle is at or above said RPM set point.  <i>See, e.g.,</i> citations for claim element 5F.

Claim 25	Corresponding Element in Audi Vehicles
at or below said manifold pressure set point and engine speed for said vehicle is at or above said RPM set point.	

Claim 26	Corresponding Element in Audi Vehicles
26A. Apparatus for optimizing operation of a vehicle, comprising:	The accused Audi vehicles include an apparatus for optimizing operation of a vehicle.  <i>See, e.g.,</i> citations for claims 1, 17.
26B. a radar detector, said radar detector determining a distance separating a vehicle having an engine and an object in front of said vehicle;	The accused Audi vehicles include a radar detector that determines a distance separating a vehicle having an engine and another object in front of the accused vehicles.  <i>See, e.g.,</i> citations for claim element 17B.
26C. a plurality of sensors coupled to a vehicle having an engine, said plurality of sensors, which collectively monitor operation of said vehicle, including a road speed sensor, and engine speed sensor, a manifold pressure sensor and a throttle position sensor;	The accused Audi vehicles include a plurality of sensors coupled to a vehicle having an engine, said plurality of sensors, which collectively monitor operation of said vehicle, including a road speed sensor, and engine speed sensor, a manifold pressure sensor and a throttle position sensor.  <i>See, e.g.,</i> citations for claim element 1B.
26D. a processor subsystem, coupled to said radar detector and each one of said plurality of sensors, to receive data therefrom;	The accused Audi vehicles include a processor subsystem, coupled to said radar detector and each one of said plurality of sensors, to receive data therefrom;  <i>See, e.g.,</i> citations for claim element 1C.
26E. a memory subsystem, coupled to said processor subsystem, said memory subsystem storing therein a first vehicle speed/stopping distance table, a manifold	The accused Audi vehicles include a memory subsystem, coupled to said processor subsystem, said memory subsystem storing therein a first vehicle speed/stopping distance table, a manifold pressure set point, RPM set point, and present and prior levels for each one of said plurality of sensors.

Claim 26	Corresponding Element in Audi Vehicles
pressure set point, RPM set point, and present and prior levels for each one of said plurality of sensors;	<i>See, e.g.</i> , citations for claim element 17E.
26F. a fuel overinjection notification circuit coupled to said processor subsystem, said fuel overinjection notification circuit issuing a notification that excessive fuel is being supplied to said engine of said vehicle;	<p>The accused Audi vehicles include a fuel overinjection notification circuit coupled to said processor subsystem, said fuel overinjection notification circuit issuing a notification that excessive fuel is being supplied to said engine of said vehicle.</p> <p><i>See, e.g.</i>, citations for claim element 1E.</p>
26G. a downshift notification circuit coupled to said processor subsystem, said downshift notification circuit issuing a notification that said engine of said vehicle is being operated at an insufficient engine speed;	<p>The accused Audi vehicles include a downshift notification circuit coupled to said processor subsystem, said downshift notification circuit issuing a notification that said engine of said vehicle is being operated at an insufficient engine speed;</p> <p><i>See, e.g.</i>, citations for claim element 7F.</p>
26H. said processor subsystem determining, based upon data received from said plurality of sensors, when to activate said fuel overinjection circuit and when to activate said downshift notification circuit;	<p>The accused Audi vehicles include a processor subsystem that determines, based upon data received from said plurality of sensors, when to activate said fuel overinjection circuit and when to activate said downshift notification circuit.</p> <p><i>See, e.g.</i>, citations for claim element 7G.</p>
26I. a vehicle proximity	The accused Audi vehicles include a vehicle proximity alarm circuit coupled to said processor

Claim 26	Corresponding Element in Audi Vehicles
<p>alarm circuit coupled to said processor subsystem, said vehicle proximity alarm circuit issuing an alarm that said vehicle is too close to said object;</p>	<p>subsystem, said vehicle proximity alarm circuit issuing an alarm that said vehicle is too close to said object.</p> <p><i>See, e.g.,</i> citations for claim element 17F.</p>
<p>26J. said processor subsystem determining, based upon data received from said radar detector, said at least one sensor and said memory subsystem, when to activate said vehicle proximity alarm circuit.</p>	<p>The accused Audi vehicles includes a processor subsystem that determines, based upon data received from said radar detector, said at least one sensor and said memory subsystem, when to activate said vehicle proximity alarm circuit.</p> <p><i>See, e.g.,</i> citations for claim element 17I.</p>

Claim 27	Corresponding Element in Audi Vehicles
27A. Apparatus for optimizing operation of a vehicle according to claim 26 wherein said processor subsystem further comprises:	The accused Audi vehicles include an apparatus for optimizing operation of a vehicle according to claim 26 wherein said processor subsystem further comprises:  <i>See, e.g.</i> , citations for claims 1, 26.
27B. means for determining when road speed for said vehicle is decreasing;	The accused Audi vehicles include a means for determining when road speed for said vehicle is decreasing.  <i>See, e.g.</i> , citations for claim element 4B.
27C. means for determining when throttle position for said vehicle is increasing; and	The accused Audi vehicles include a means for determining when throttle position for said vehicle is increasing.  <i>See, e.g.</i> , citations for claim element 4C.
27D. means for determining when manifold pressure for said vehicle is increasing; and	The accused Audi vehicles include a means for determining when manifold pressure for said vehicle is increasing.  <i>See, e.g.</i> , citations for claim element 4D.
27E. means for determining when engine speed for said vehicle is decreasing;	The accused Audi vehicles include a means for determining when engine speed for said vehicle is decreasing.  <i>See, e.g.</i> , citations for claim element 4E.
27F. said processor subsystem activating said downshift notification circuit if both road speed and engine speed are	On information and belief, the accused Audi vehicles include a processor subsystem that activates said downshift notification circuit if both road speed and engine speed are decreasing and both throttle position and manifold pressure for said vehicle are increasing.  <i>See, e.g.</i> , citations for claim element 10F.

<b>Claim 27</b>	<b>Corresponding Element in Audi Vehicles</b>
decreasing and both throttle position and manifold pressure for said vehicle are increasing.	



Claim 28	Corresponding Element in Audi Vehicles
28A. Apparatus for optimizing operation of a vehicle, comprising:	The accused Audi vehicles include an apparatus for optimizing operation of a vehicle.  <i>See, e.g.</i> , citations for claim 1.
28B. a plurality of sensors coupled to a vehicle having an engine, said plurality of sensors, which collectively monitor operation of said vehicle, including a road speed sensor, an engine speed sensor, a manifold pressure sensor and a throttle position sensor;	The accused Audi vehicles include a plurality of sensors coupled to the vehicle having an engine, said plurality of sensors, which collectively monitor operation of said vehicle, including a road speed sensor, an engine speed sensor, a manifold pressure sensor and a throttle position sensor  <i>See, e.g.</i> , citations for claim element 1B.
28C. a processor subsystem, coupled to each one of said plurality of sensors, to receive data therefrom;	The accused Audi vehicles include a processor subsystem, coupled to each one of said plurality of sensors, to receive data therefrom.  <i>See, e.g.</i> , citations for claim element 1C.
28D. a fuel overinjection notification circuit coupled to said processor subsystem, said fuel overinjection notification circuit issuing a notification that excessive fuel is being supplied to said engine of said vehicle;	The accused Audi vehicles include a fuel overinjection notification circuit coupled to said processor subsystem, said fuel overinjection notification circuit issuing a notification that excessive fuel is being supplied to said engine of said vehicle.  <i>See, e.g.</i> , citations for claim element 1E.
28E. said processor subsystem determining whether to activate said fuel overinjection notification	The accused Audi vehicles include a processor subsystem that determines whether to activate said fuel overinjection notification sensor based upon data received from said road speed sensor, said throttle position sensor and said manifold pressure sensor.

<b>Claim 28</b>	<b>Corresponding Element in Audi Vehicles</b>
sensor based upon data received from said road speed sensor, said throttle position sensor and said manifold pressure sensor.	<i>See, e.g.</i> , citations for claim element 1G.

Claim 29	Corresponding Element in Audi Vehicles
29A. Apparatus according to claim 28 and further comprising:	The accused Audi vehicles include an apparatus according to claim 28 and further comprising:  <i>See, e.g.,</i> citations for claim 1, 28.
29B. a memory subsystem, coupled to said processor subsystem, said memory subsystem maintaining a manifold pressure set point;	The accused Audi vehicles include a memory subsystem, coupled to said processor subsystem, said memory subsystem maintaining a manifold pressure set point.  <i>See, e.g.,</i> citations for claim element 1D.
29C. said processor subsystem activating said fuel overinjection notification circuit upon determining that: (1) based upon data received from said road speed sensor, road speed of said vehicle is increasing; (2) based upon data received from said throttle position sensor, throttle position for said vehicle is increasing; and (3) based upon data received from said manifold pressure sensor, manifold pressure for said vehicle exceeds said manifold pressure set point.	On information and belief, the accused Audi vehicles include a processor subsystem that activates said fuel overinjection notification circuit upon determining that: (1) based upon data received from said road speed sensor, road speed of said vehicle is increasing; (2) based upon data received from said throttle position sensor, throttle position for said vehicle is increasing; and (3) based upon data received from said manifold pressure sensor, manifold pressure for said vehicle exceeds said manifold pressure set point.  <i>See, e.g.,</i> citations for claim element 1G.

Claim 30	Corresponding Element in Audi Vehicles
30A. Apparatus according to claim 28, wherein:	<p>The accused Audi vehicles include an apparatus according to claim 28.</p> <p><i>See, e.g.,</i> citations for claims 1, 28.</p>
30B. said plurality of sensors coupled to said vehicle further include an engine speed sensor;	<p>The accused Audi vehicles include a plurality of sensors coupled to said vehicle further including an engine speed sensor;</p> <p><i>See, e.g.,</i> citations for claim element 1B.</p>
30C. said processor subsystem activating said fuel overinjection notification circuit upon determining that: (1) based upon data received from said road speed sensor, road speed of said vehicle is decreasing; (2) based upon data received from said throttle position sensor, throttle position for said vehicle is increasing; (3) based upon data received from said manifold pressure sensor, manifold pressure for said vehicle is increasing; and (4) based upon data received from said engine speed sensor,	<p>On information and belief, the accused Audi vehicles include a processor subsystem that activates said fuel overinjection notification circuit upon determining that: (1) based upon data received from said road speed sensor, road speed of said vehicle is decreasing; (2) based upon data received from said throttle position sensor, throttle position for said vehicle is increasing; (3) based upon data received from said manifold pressure sensor, manifold pressure for said vehicle is increasing; and (4) based upon data received from said engine speed sensor, engine speed for said vehicle is decreasing.</p> <p><i>See, e.g.,</i> citations for claim element 1G.</p>

<b>Claim 30</b>	<b>Corresponding Element in Audi Vehicles</b>
engine speed for said vehicle is decreasing.	

Claim 31	Corresponding Element in Audi Vehicles
31A. Apparatus for optimizing operation of a vehicle, comprising:	The accused Audi vehicles include an apparatus for optimizing operation of a vehicle. <i>See, e.g.,</i> citations for claims 1, 17.
31B. a radar detector, said radar detector determining a distance separating a vehicle having an engine and an object in front of said vehicle;	The accused Audi vehicles include a radar detector that determines a distance separating a vehicle having an engine and another object in front of the accused vehicles. <i>See, e.g.,</i> citations for claim element 17B.
31C. at least one sensor coupled to said vehicle for monitoring operation thereof, said at least one sensor including a road speed sensor.	The accused Audi vehicles include at least one sensor coupled to said vehicle for monitoring operation thereof, said at least one sensor including a road speed sensor. <i>See, e.g.,</i> citations for claim element 1B.
31D. a processor subsystem, coupled to said radar detector and said at least one sensor, to receive data therefrom;	The accused Audi vehicles include a processor subsystem, coupled to said radar detector and said at least one sensor, to receive data therefrom. <i>See, e.g.,</i> citations for claim element 17D.
31E. a memory subsystem, coupled to said processor subsystem, said memory subsystem storing a first vehicle speed/stopping distance table.	The accused Audi vehicles include a memory subsystem, coupled to said processor subsystem, said memory subsystem storing a first vehicle speed/stopping distance table. <i>See, e.g.,</i> citations for claim element 17E.
31F. a vehicle proximity alarm circuit coupled to said	The accused Audi vehicles include a vehicle proximity alarm circuit coupled to said processor subsystem, said vehicle proximity alarm circuit issuing an alarm that said vehicle is too close to

Claim 31	Corresponding Element in Audi Vehicles
processor subsystem, said vehicle proximity alarm circuit issuing an alarm that said vehicle is too close to said object;	said object.  <i>See, e.g.,</i> citations for claim element 17F.
31G. said processor subsystem determining whether to activate said vehicle proximity alarm circuit based upon separation distance data received from said radar detector, vehicle speed data received from said road speed sensor and said first vehicle speed/stopping distance table stored in said memory subsystem.	On information and belief, the accused Audi vehicles includes a processor subsystem that determines whether to activate said vehicle proximity alarm circuit based upon separation distance data received from said radar detector, vehicle speed data received from said road speed sensor and said first vehicle speed/stopping distance table stored in said memory subsystem.  <i>See, e.g.,</i> citations for claim element 17I.

Claim 32	Corresponding Element in Audi Vehicles
32A. Apparatus for optimizing operation of a vehicle according to claim 31 wherein:	The accused Audi vehicles include an apparatus for optimizing operation of a vehicle according to claim 31.  <i>See, e.g.,</i> citations for claim 31.
32B. said at least one sensor further includes a	The accused Audi vehicles include at least one sensor further including a windshield wiper sensor for indicating whether a windshield wiper of said vehicle is activated.

Claim 32	Corresponding Element in Audi Vehicles
windshield wiper sensor for indicating whether a windshield wiper of said vehicle is activated; and	<i>See, e.g.</i> , citations for claim element 18B.
32C. said memory subsystem further storing a second vehicle speed/stopping distance table.	The accused Audi vehicles include a memory subsystem further storing a second vehicle speed/stopping distance table.  <i>See, e.g.</i> , citations for claim element 18C.
32D. if said windshield wiper sensor indicates that said windshield wiper is deactivated, said processor subsystem determining whether to activate said vehicle proximity alarm circuit based upon data received from said radar detector, said road speed sensor and said first vehicle speed/stopping distance table stored in said memory subsystem;	On information and belief, the accused Audi vehicles include an apparatus for optimizing operation of a vehicle according to claim 31 wherein if said windshield wiper sensor indicates that said windshield wiper is deactivated, said processor subsystem determining whether to activate said vehicle proximity alarm circuit based upon data received from said radar detector, said road speed sensor and said first vehicle speed/stopping distance table stored in said memory subsystem.  <i>See, e.g.</i> , citations for claim element 17I.
32E. if said windshield wiper sensor indicates that said windshield wiper is activated, said processor subsystem determining whether to activate said vehicle proximity alarm	On information and belief, the accused Audi vehicles include an apparatus for optimizing operation of a vehicle according to claim 31 wherein if said windshield wiper sensor indicates that said windshield wiper is activated, said processor subsystem determining whether to activate said vehicle proximity alarm circuit based upon data received from said radar detector, said road speed sensor and said second vehicle speed/stopping distance table stored in said memory subsystem.



Claim 32	Corresponding Element in Audi Vehicles
<p>circuit based upon data received from said radar detector, said road speed sensor and said second vehicle speed/stopping distance table stored in said memory subsystem.</p>	<p><i>See, e.g.</i>, citations for claim element 17I.</p>

## **EXHIBIT 7**



**A. Identification of Infringed Claims and Applicable Statutory Section of 35 U.S.C. § 271**

Claims 1-2, 4-5, 7-8, 10, 12-13, 15, and 17-32 of U.S. Patent No. 5,954,781 are directly infringed under 35 U.S.C § 271(a) by the accused Mercedes vehicles identified below.

**B. Identification of Accused Instrumentalities By Claim**

As set forth in the accompanying claim chart, the Mercedes-Benz S-Class, C-Class Coupe, C-Class Sedan, CL-Class, CLA-Class, CLS-Class, E-Class Coupe/Cabriolet, E-Class Sedan/Wagon, G-Class, GL-Class, GLK-Class, M-Class, SL-Class, SLK-Class, and SLS-Class vehicles that include the identified features, infringe one or more of the claims identified above.

On a claim-by-claim basis, the following Mercedes vehicles are accused of infringement by Velocity:

Claim 1 - Mercedes S-Class, C-Class Coupe, C-Class Sedan, CL-Class, CLA-Class, CLS-Class, E-Class Coupe/Cabriolet, E-Class Sedan/Wagon, G-Class, GL-Class, GLK-Class, M-Class, SL-Class, SLK-Class, and SLS-Class;

Claim 2 - Mercedes S-Class, C-Class Coupe, C-Class Sedan, CL-Class, CLA-Class, CLS-Class, E-Class Coupe/Cabriolet, E-Class Sedan/Wagon, G-Class, GL-Class, GLK-Class, M-Class, SL-Class, SLK-Class, and SLS-Class;

Claim 4 - Mercedes S-Class, C-Class Coupe, C-Class Sedan, CL-Class, CLA-Class, CLS-Class, E-Class Coupe/Cabriolet, E-Class Sedan/Wagon, G-Class, GL-Class, GLK-Class, M-Class, SL-Class, SLK-Class, and SLS-Class;

Claim 5 - Mercedes S-Class, C-Class Coupe, C-Class Sedan, CL-Class, CLA-Class, CLS-Class, E-Class Coupe/Cabriolet, E-Class Sedan/Wagon, G-Class, GL-Class, GLK-Class, M-Class, SL-Class, SLK-Class, and SLS-Class;

Claim 7 - Mercedes S-Class, C-Class Coupe, C-Class Sedan, CL-Class, CLA-Class, CLS-Class, E-Class Coupe/Cabriolet, E-Class Sedan/Wagon, G-Class, GL-Class, GLK-Class, M-Class, SL-Class, SLK-Class, and SLS-Class;

Claim 8 - Mercedes S-Class, C-Class Coupe, C-Class Sedan, CL-Class, CLA-Class, CLS-Class, E-Class Coupe/Cabriolet, E-Class Sedan/Wagon, G-Class, GL-Class, GLK-Class, M-Class, SL-Class, SLK-Class, and SLS-Class;



Claim 25 - Mercedes S-Class, C-Class Coupe, C-Class Sedan, CL-Class, CLA-Class, CLS-Class, E-Class Coupe/Cabriolet, E-Class Sedan/Wagon, G-Class, GL-Class, GLK-Class, M-Class, SL-Class, SLK-Class, and SLS-Class;

Claim 26 - Mercedes S-Class, C-Class Coupe, C-Class Sedan, CL-Class, CLA-Class, CLS-Class, E-Class Coupe/Cabriolet, E-Class Sedan/Wagon, G-Class, GL-Class, GLK-Class, M-Class, SL-Class, SLK-Class, and SLS-Class;

Claim 27 - Mercedes S-Class, C-Class Coupe, C-Class Sedan, CL-Class, CLA-Class, CLS-Class, E-Class Coupe/Cabriolet, E-Class Sedan/Wagon, G-Class, GL-Class, GLK-Class, M-Class, SL-Class, SLK-Class, and SLS-Class;

Claim 28 - Mercedes S-Class, C-Class Coupe, C-Class Sedan, CL-Class, CLA-Class, CLS-Class, E-Class Coupe/Cabriolet, E-Class Sedan/Wagon, G-Class, GL-Class, GLK-Class, M-Class, SL-Class, SLK-Class, and SLS-Class;

Claim 29 - Mercedes S-Class, C-Class Coupe, C-Class Sedan, CL-Class, CLA-Class, CLS-Class, E-Class Coupe/Cabriolet, E-Class Sedan/Wagon, G-Class, GL-Class, GLK-Class, M-Class, SL-Class, SLK-Class, and SLS-Class;

Claim 30 - Mercedes S-Class, C-Class Coupe, C-Class Sedan, CL-Class, CLA-Class, CLS-Class, E-Class Coupe/Cabriolet, E-Class Sedan/Wagon, G-Class, GL-Class, GLK-Class, M-Class, SL-Class, SLK-Class, and SLS-Class;

Claim 31 - Mercedes S-Class, C-Class Coupe, C-Class Sedan, CL-Class, CLA-Class, CLS-Class, E-Class Coupe/Cabriolet, E-Class Sedan/Wagon, G-Class, GL-Class, GLK-Class, M-Class, SL-Class, SLK-Class, and SLS-Class;

Claim 32 - Mercedes S-Class, C-Class Coupe, C-Class Sedan, CL-Class, CLA-Class, CLS-Class, E-Class Coupe/Cabriolet, E-Class Sedan/Wagon, G-Class, GL-Class, GLK-Class, M-Class, SL-Class, SLK-Class, and SLS-Class.

**C. Claim Chart Comparing Each Element of the Asserted Claims to the Accused Instrumentalities**

A claim chart identifying where each element of each asserted claim is found within each Accused Mercedes vehicle is attached.

**D. Identification of Whether Each Element of Each Asserted Claim is Present in the Accused Instrumentalities Literally or Under the Doctrine of Equivalents**

At this time, Velocity asserts that all of the asserted claim elements are literally present in the Accused Mercedes vehicles.

At this time, sections (e)-(f) of Local Patent Rule 2.2 are not applicable. Velocity expressly reserves the right to revise, amend and supplement these contentions as discovery progresses and new information becomes available.

Dated: March 12, 2014

Respectfully submitted,

/s/ James A. Shimota

James A. Shimota

James A. Shimota (IL Bar No. 6270603)  
Howard E. Levin (IL Bar No. 6286712)  
Adam R. Brausa (IL Bar No. 6292447)  
Aaron C. Taggart (IL Bar No. 6302068)  
MAVRAKAKIS LAW GROUP LLP  
180 North LaSalle Street, Suite 2215  
Chicago, Illinois 60601  
Telephone: 312-216-1620  
Facsimile: 312-216-1621  
jshimota@mavllp.com  
hlevin@mavllp.com  
abrausa@mavllp.com  
ataggart@mavllp.com

*Counsel for Plaintiff Velocity Patent LLC*

**PROOF OF SERVICE**

The undersigned hereby certifies that a true and correct copy of the above and foregoing document has been served on March 12, 2014, by electronic mail to:

<p><b>HOGAN LOVELLS</b></p> <p>Raymond A. Kurz Celine J. Crowson 555 13<sup>th</sup> Street, NW Washington, DC 20004 (202) 637-5683 (202) 637-5703 Raymond.kurz@hoganlovells.com Celine.crowson@hoganlovells.com</p> <p><b>Served by Electronic Mail</b></p>	<p><b>SCHOPF &amp; WEISS LLP</b></p> <p>David L. De Bruin Steven A. Weiss Anand C. Mathew One South Wacker Drive, 28<sup>th</sup> Floor Chicago, IL 60606 (312) 701-9328 (312) 701-9311 (312) 701-9339 debruin@sw.com Weiss@sw.com Mathew@sw.com</p> <p><b>Served by Electronic Mail</b></p>
--	--

Attorneys for Defendants  
Mercedes-Benz USA, LLC and Mercedes-Benz U.S. International Inc.

*/s/ James C. Rally*

Project Assistant  
Mavrakakis Law Group LLP



**Velocity Patent LLC Preliminary Infringement Contentions Against Mercedes-Benz Defendants Pursuant to N.D. III. LPR 2.1**

Claim 1	Corresponding Element in Mercedes-Benz Vehicles <sup>1</sup>
<p>1.A. Apparatus for optimizing operation of a vehicle, comprising:<sup>2</sup></p>	<p>The accused Mercedes-Benz vehicles<sup>3</sup> include an apparatus for optimizing operation of a vehicle.</p> <p>For example, the accused Mercedes-Benz vehicles include a motor electronics (ME) control unit with one or more computer processors that monitor various vehicle systems and optimize the fuel economy, safety and performance of the vehicle.</p>

<sup>1</sup> Velocity contends that each element of the asserted claims is literally and directly infringed by the accused vehicles.

<sup>2</sup> Velocity's citations related to any claim preamble in this claim chart should not be interpreted as an admission that the preamble is limiting.

<sup>3</sup> The accused features and vehicles identified in these preliminary contentions are representative only. Velocity accuses all Mercedes-Benz vehicle models for model years 2007 to 2014 that incorporate features that are similar to the accused features identified in these preliminary contentions, including at least the: a) S-Class; b) C-Class Coupe; c) C-Class Sedan; d) CL-Class; e) CL-Class; f) CLS-Class; g) E-Class Coupe and Cabriolet; h) E-Class Sedan and Wagon; i) G-Class; j) GL-Class; k) GLK-Class; l) M-Class; m) SL-Class; n) SLK-Class; and o) SLS-Class. Discovery has just begun in this case. Velocity reserves the right to supplement and identify additional infringing models (e.g., 2015 models currently being tested) as it learns facts through discovery.

**Claim 1**

**Corresponding Element in Mercedes-Benz Vehicles<sup>1</sup>**

**ME (motor electronics) control unit**

The MED 17.7.1 engine control builds on experiences with the MED 9 of previous engines. The following features have been implemented in this new engine control MED 17.7.1 in an identical modular housing:

- Modular design as a standardized control unit for all new V8 engines with direct injection
- In contrast to the predecessor unit, no separate water cooling of the injector power amplifiers but air convection via cooling fins instead
- No additional component carriers in the control unit for the injector power amplifiers
- Single-processor concept with 150 MHz clock frequency instead of dual-core concept with 66 MHz each
- Significantly increased flash and RAM memory capacities
- Weight reduction by 0.2 kg



PS4.2-317-1-00

*Engine M 157*

*N3/10 ME-SFI [ME] control unit*

Claim 1	Corresponding Element in Mercedes-Benz Vehicles
	<p data-bbox="349 1249 373 1281">Task</p> <p data-bbox="397 1249 511 1780">The engine control unit combines with the sensors and actuators of engine M 157 to form the engine control system. The following systems and functions are controlled and coordinated by the engine control unit according to the input signals:</p> <ul data-bbox="527 1249 876 1780" style="list-style-type: none"> <li>• Ignition system</li> <li>• Fuel supply</li> <li>• Injection control</li> <li>• Electronic accelerator</li> <li>• Diagnosis and fault storage</li> <li>• Engine start/stop function</li> <li>• Drive authorization system and immobilizer</li> <li>• Controlled camshaft adjustment</li> <li>• Thermal management</li> <li>• Torque interface</li> <li>• Alternator interface</li> <li>• Oil pressure control</li> <li>• Lambda control</li> <li>• Tank diagnosis</li> <li>• Purging</li> </ul>

Claim 1 Corresponding Element in Mercedes-Benz Vehicles

Engine control

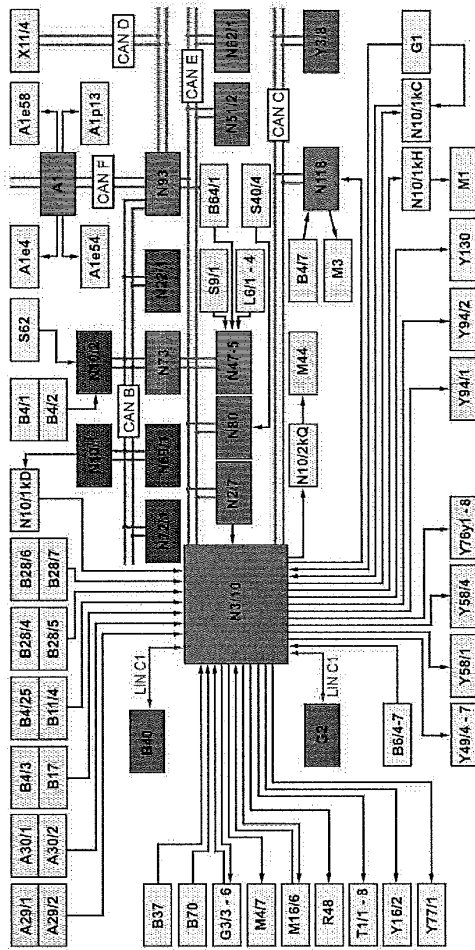

Block diagram of engine M 157 (shown on model 22)

1071422308

**Claim 1**

**Corresponding Element in Mercedes-Benz Vehicles<sup>1</sup>**

<p>1B. a plurality of sensors coupled to a vehicle having an engine, said plurality of sensors, which collectively monitor operation of said engine, said plurality of sensors, which collectively monitor operation of said engine, including a road speed sensor, an engine speed sensor, a manifold pressure sensor and a throttle position sensor.</p>	<p>A1 Intermittent starter A164 Fuel sensor warning lamp A165 Coolant temperature indicator lamp A166 Engine diagnostic indicator lamp A167 Multifunction display A23V1 Front knock sensor (left side of engine) A23V2 Rear knock sensor (right side of engine) A33V1 Front crank sensor (left side of engine) A33V2 Rear crank sensor (right side of engine) B4V1 Fuel level indicator sensor B4V2 Fuel level transmitter sensor B4V3 Fuel level fuel B4V4 Tank pressure sensor B4V5 Fuel coils (FPA), USA version B4V6 Fuel pressure sensor B4V7 Fuel pressure sensor B4V8 Intake manifold fuel sensor left B4V9 Intake manifold fuel sensor right B4V10 Exhaust manifold fuel sensor left B4V11 Exhaust manifold fuel sensor right</p>	<p>B11/4 Coolant temperature sensor B17 Pressure sensor downstream of air filter B28/4 Pressure sensor downstream of air filter B38/5 Pressure sensor downstream of air filter B38/6 Pressure sensor B38/7 Pressure sensor downstream of throttle valve B39/5 Accelerator pedal sensor B40 Oil level sensor B42/1 Brake system sensor C1 Control unit (ECU) C2 Air filter sensor C3 Left CO<sub>2</sub> sensor upstream of catalytic converter C3/4 Right CO<sub>2</sub> sensor upstream of catalytic converter C3/5 Left CO<sub>2</sub> sensor downstream of catalytic converter C3/6 Right CO<sub>2</sub> sensor downstream of catalytic converter</p>	<p>U1/1 Left hand turn indicator U2/2 Right hand turn indicator U3/3 Left rear turn indicator U4/4 Right rear turn indicator M1 Starter M2 Fuel pump M3 Engine and/or preheating electric actuator (with integrated control circuit) valve (M318) M44 Charge air cooler, circulation pump M277 Hydraulic system (P10700, air) M42/5 M42/6 M42/7 M42/8 M42/9 M42/10 M42/11 M42/12 M42/13 M42/14 M42/15 M42/16 M42/17 M42/18 M42/19 M42/20 M42/21 M42/22 M42/23 M42/24 M42/25 M42/26 M42/27 M42/28 M42/29 M42/30 M42/31 M42/32 M42/33 M42/34 M42/35 M42/36 M42/37 M42/38 M42/39 M42/40 M42/41 M42/42 M42/43 M42/44 M42/45 M42/46 M42/47 M42/48 M42/49 M42/50 M42/51 M42/52 M42/53 M42/54 M42/55 M42/56 M42/57 M42/58 M42/59 M42/60 M42/61 M42/62 M42/63 M42/64 M42/65 M42/66 M42/67 M42/68 M42/69 M42/70 M42/71 M42/72 M42/73 M42/74 M42/75 M42/76 M42/77 M42/78 M42/79 M42/80 M42/81 M42/82 M42/83 M42/84 M42/85 M42/86 M42/87 M42/88 M42/89 M42/90 M42/91 M42/92 M42/93 M42/94 M42/95 M42/96 M42/97 M42/98 M42/99 M42/100 M42/101 M42/102 M42/103 M42/104 M42/105 M42/106 M42/107 M42/108 M42/109 M42/110 M42/111 M42/112 M42/113 M42/114 M42/115 M42/116 M42/117 M42/118 M42/119 M42/120 M42/121 M42/122 M42/123 M42/124 M42/125 M42/126 M42/127 M42/128 M42/129 M42/130 M42/131 M42/132 M42/133 M42/134 M42/135 M42/136 M42/137 M42/138 M42/139 M42/140 M42/141 M42/142 M42/143 M42/144 M42/145 M42/146 M42/147 M42/148 M42/149 M42/150 M42/151 M42/152 M42/153 M42/154 M42/155 M42/156 M42/157 M42/158 M42/159 M42/160 M42/161 M42/162 M42/163 M42/164 M42/165 M42/166 M42/167 M42/168 M42/169 M42/170 M42/171 M42/172 M42/173 M42/174 M42/175 M42/176 M42/177 M42/178 M42/179 M42/180 M42/181 M42/182 M42/183 M42/184 M42/185 M42/186 M42/187 M42/188 M42/189 M42/190 M42/191 M42/192 M42/193 M42/194 M42/195 M42/196 M42/197 M42/198 M42/199 M42/200 M42/201 M42/202 M42/203 M42/204 M42/205 M42/206 M42/207 M42/208 M42/209 M42/210 M42/211 M42/212 M42/213 M42/214 M42/215 M42/216 M42/217 M42/218 M42/219 M42/220 M42/221 M42/222 M42/223 M42/224 M42/225 M42/226 M42/227 M42/228 M42/229 M42/230 M42/231 M42/232 M42/233 M42/234 M42/235 M42/236 M42/237 M42/238 M42/239 M42/240 M42/241 M42/242 M42/243 M42/244 M42/245 M42/246 M42/247 M42/248 M42/249 M42/250 M42/251 M42/252 M42/253 M42/254 M42/255 M42/256 M42/257 M42/258 M42/259 M42/260 M42/261 M42/262 M42/263 M42/264 M42/265 M42/266 M42/267 M42/268 M42/269 M42/270 M42/271 M42/272 M42/273 M42/274 M42/275 M42/276 M42/277 M42/278 M42/279 M42/280 M42/281 M42/282 M42/283 M42/284 M42/285 M42/286 M42/287 M42/288 M42/289 M42/290 M42/291 M42/292 M42/293 M42/294 M42/295 M42/296 M42/297 M42/298 M42/299 M42/300 M42/301 M42/302 M42/303 M42/304 M42/305 M42/306 M42/307 M42/308 M42/309 M42/310 M42/311 M42/312 M42/313 M42/314 M42/315 M42/316 M42/317 M42/318 M42/319 M42/320 M42/321 M42/322 M42/323 M42/324 M42/325 M42/326 M42/327 M42/328 M42/329 M42/330 M42/331 M42/332 M42/333 M42/334 M42/335 M42/336 M42/337 M42/338 M42/339 M42/340 M42/341 M42/342 M42/343 M42/344 M42/345 M42/346 M42/347 M42/348 M42/349 M42/350 M42/351 M42/352 M42/353 M42/354 M42/355 M42/356 M42/357 M42/358 M42/359 M42/360 M42/361 M42/362 M42/363 M42/364 M42/365 M42/366 M42/367 M42/368 M42/369 M42/370 M42/371 M42/372 M42/373 M42/374 M42/375 M42/376 M42/377 M42/378 M42/379 M42/380 M42/381 M42/382 M42/383 M42/384 M42/385 M42/386 M42/387 M42/388 M42/389 M42/390 M42/391 M42/392 M42/393 M42/394 M42/395 M42/396 M42/397 M42/398 M42/399 M42/400 M42/401 M42/402 M42/403 M42/404 M42/405 M42/406 M42/407 M42/408 M42/409 M42/410 M42/411 M42/412 M42/413 M42/414 M42/415 M42/416 M42/417 M42/418 M42/419 M42/420 M42/421 M42/422 M42/423 M42/424 M42/425 M42/426 M42/427 M42/428 M42/429 M42/430 M42/431 M42/432 M42/433 M42/434 M42/435 M42/436 M42/437 M42/438 M42/439 M42/440 M42/441 M42/442 M42/443 M42/444 M42/445 M42/446 M42/447 M42/448 M42/449 M42/450 M42/451 M42/452 M42/453 M42/454 M42/455 M42/456 M42/457 M42/458 M42/459 M42/460 M42/461 M42/462 M42/463 M42/464 M42/465 M42/466 M42/467 M42/468 M42/469 M42/470 M42/471 M42/472 M42/473 M42/474 M42/475 M42/476 M42/477 M42/478 M42/479 M42/480 M42/481 M42/482 M42/483 M42/484 M42/485 M42/486 M42/487 M42/488 M42/489 M42/490 M42/491 M42/492 M42/493 M42/494 M42/495 M42/496 M42/497 M42/498 M42/499 M42/500 M42/501 M42/502 M42/503 M42/504 M42/505 M42/506 M42/507 M42/508 M42/509 M42/510 M42/511 M42/512 M42/513 M42/514 M42/515 M42/516 M42/517 M42/518 M42/519 M42/520 M42/521 M42/522 M42/523 M42/524 M42/525 M42/526 M42/527 M42/528 M42/529 M42/530 M42/531 M42/532 M42/533 M42/534 M42/535 M42/536 M42/537 M42/538 M42/539 M42/540 M42/541 M42/542 M42/543 M42/544 M42/545 M42/546 M42/547 M42/548 M42/549 M42/550 M42/551 M42/552 M42/553 M42/554 M42/555 M42/556 M42/557 M42/558 M42/559 M42/560 M42/561 M42/562 M42/563 M42/564 M42/565 M42/566 M42/567 M42/568 M42/569 M42/570 M42/571 M42/572 M42/573 M42/574 M42/575 M42/576 M42/577 M42/578 M42/579 M42/580 M42/581 M42/582 M42/583 M42/584 M42/585 M42/586 M42/587 M42/588 M42/589 M42/590 M42/591 M42/592 M42/593 M42/594 M42/595 M42/596 M42/597 M42/598 M42/599 M42/600 M42/601 M42/602 M42/603 M42/604 M42/605 M42/606 M42/607 M42/608 M42/609 M42/610 M42/611 M42/612 M42/613 M42/614 M42/615 M42/616 M42/617 M42/618 M42/619 M42/620 M42/621 M42/622 M42/623 M42/624 M42/625 M42/626 M42/627 M42/628 M42/629 M42/630 M42/631 M42/632 M42/633 M42/634 M42/635 M42/636 M42/637 M42/638 M42/639 M42/640 M42/641 M42/642 M42/643 M42/644 M42/645 M42/646 M42/647 M42/648 M42/649 M42/650 M42/651 M42/652 M42/653 M42/654 M42/655 M42/656 M42/657 M42/658 M42/659 M42/660 M42/661 M42/662 M42/663 M42/664 M42/665 M42/666 M42/667 M42/668 M42/669 M42/670 M42/671 M42/672 M42/673 M42/674 M42/675 M42/676 M42/677 M42/678 M42/679 M42/680 M42/681 M42/682 M42/683 M42/684 M42/685 M42/686 M42/687 M42/688 M42/689 M42/690 M42/691 M42/692 M42/693 M42/694 M42/695 M42/696 M42/697 M42/698 M42/699 M42/700 M42/701 M42/702 M42/703 M42/704 M42/705 M42/706 M42/707 M42/708 M42/709 M42/710 M42/711 M42/712 M42/713 M42/714 M42/715 M42/716 M42/717 M42/718 M42/719 M42/720 M42/721 M42/722 M42/723 M42/724 M42/725 M42/726 M42/727 M42/728 M42/729 M42/730 M42/731 M42/732 M42/733 M42/734 M42/735 M42/736 M42/737 M42/738 M42/739 M42/740 M42/741 M42/742 M42/743 M42/744 M42/745 M42/746 M42/747 M42/748 M42/749 M42/750 M42/751 M42/752 M42/753 M42/754 M42/755 M42/756 M42/757 M42/758 M42/759 M42/760 M42/761 M42/762 M42/763 M42/764 M42/765 M42/766 M42/767 M42/768 M42/769 M42/770 M42/771 M42/772 M42/773 M42/774 M42/775 M42/776 M42/777 M42/778 M42/779 M42/780 M42/781 M42/782 M42/783 M42/784 M42/785 M42/786 M42/787 M42/788 M42/789 M42/790 M42/791 M42/792 M42/793 M42/794 M42/795 M42/796 M42/797 M42/798 M42/799 M42/800 M42/801 M42/802 M42/803 M42/804 M42/805 M42/806 M42/807 M42/808 M42/809 M42/810 M42/811 M42/812 M42/813 M42/814 M42/815 M42/816 M42/817 M42/818 M42/819 M42/820 M42/821 M42/822 M42/823 M42/824 M42/825 M42/826 M42/827 M42/828 M42/829 M42/830 M42/831 M42/832 M42/833 M42/834 M42/835 M42/836 M42/837 M42/838 M42/839 M42/840 M42/841 M42/842 M42/843 M42/844 M42/845 M42/846 M42/847 M42/848 M42/849 M42/850 M42/851 M42/852 M42/853 M42/854 M42/855 M42/856 M42/857 M42/858 M42/859 M42/860 M42/861 M42/862 M42/863 M42/864 M42/865 M42/866 M42/867 M42/868 M42/869 M42/870 M42/871 M42/872 M42/873 M42/874 M42/875 M42/876 M42/877 M42/878 M42/879 M42/880 M42/881 M42/882 M42/883 M42/884 M42/885 M42/886 M42/887 M42/888 M42/889 M42/890 M42/891 M42/892 M42/893 M42/894 M42/895 M42/896 M42/897 M42/898 M42/899 M42/900 M42/901 M42/902 M42/903 M42/904 M42/905 M42/906 M42/907 M42/908 M42/909 M42/910 M42/911 M42/912 M42/913 M42/914 M42/915 M42/916 M42/917 M42/918 M42/919 M42/920 M42/921 M42/922 M42/923 M42/924 M42/925 M42/926 M42/927 M42/928 M42/929 M42/930 M42/931 M42/932 M42/933 M42/934 M42/935 M42/936 M42/937 M42/938 M42/939 M42/940 M42/941 M42/942 M42/943 M42/944 M42/945 M42/946 M42/947 M42/948 M42/949 M42/950 M42/951 M42/952 M42/953 M42/954 M42/955 M42/956 M42/957 M42/958 M42/959 M42/960 M42/961 M42/962 M42/963 M42/964 M42/965 M42/966 M42/967 M42/968 M42/969 M42/970 M42/971 M42/972 M42/973 M42/974 M42/975 M42/976 M42/977 M42/978 M42/979 M42/980 M42/981 M42/982 M42/983 M42/984 M42/985 M42/986 M42/987 M42/988 M42/989 M42/990 M42/991 M42/992 M42/993 M42/994 M42/995 M42/996 M42/997 M42/998 M42/999 M42/1000</p>
--	---	--	--

(See, e.g., Ex. Mercedes-Benz-1, Introduction of the New Generation of V-Engines, 8-cylinder M 157 AMG at 49-51).

While the citations above relate specifically to the Mercedes-Benz M157 engine, upon information and belief, Mercedes-Benz's other engines (e.g., the 4-cylinder M270/M274, 6-cylinder M272/M276, 8-cylinder M155/M156/M273/M278/M157/M159 and 12-cylinder M158/M275/M285) have the same or similar motor electronics (ME) control units with one or more computer processors.

The accused Mercedes-Benz vehicles include a plurality of sensors coupled to the vehicle having an engine, said plurality of sensors, which collectively monitor operation of said vehicle, including a road speed sensor, an engine speed sensor, a manifold pressure sensor and a throttle position sensor.

1B. a plurality of sensors coupled to a vehicle having an engine, said plurality of sensors, which collectively monitor operation of said engine, said plurality of sensors, which collectively monitor operation of said engine, including a road speed sensor, an engine speed sensor, a manifold pressure sensor and a throttle position sensor.

<p align="center"><b>Claim 1</b></p>	<p align="center"><b>Corresponding Element in Mercedes-Benz Vehicles<sup>1</sup></b></p>
<p>vehicle, including a road speed sensor, an engine pressure sensor and a throttle position sensor;</p>	<p>See, e.g., citations for claim element 1A (describing processor controlled vehicle systems that monitor vehicle system characteristics and operations).</p> <p>Upon information and belief, the accused Mercedes-Benz vehicles include an engine. More specifically, upon information and belief, the Mercedes-Benz engines include the 4-cylinder M270/M274, 6-cylinder M272/M276, 8-cylinder M155/M156/M273/M278/M157/M159 and 12-cylinder M158/M275/M285.</p> <p>1B1. The accused Mercedes-Benz vehicles include one or more road speed sensors, engine speed sensors, manifold pressure sensors, and throttle position sensors. For example, the Mercedes-Benz M157 engine includes a MED 17.7.1 engine control unit with a processor that is coupled to a road speed sensor, an engine speed sensor, a manifold pressure sensor and a throttle position sensor. Upon information and belief, Mercedes-Benz's other engines have the same or similar engine control features.</p>

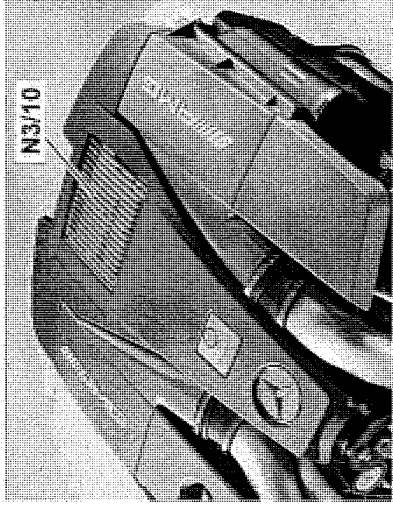
Claim 1	Corresponding Element in Mercedes-Benz Vehicles
<p><b>ME (motor electronics) control unit</b></p> <p>The MED 17.7.1 engine control builds on experiences with the MED 9 of previous engines. The following features have been implemented in this new engine control MED 17.7.1 in an identical modular housing:</p> <ul style="list-style-type: none"> <li>• Modular design as a standardized control unit for all new V8 engines with direct injection.</li> <li>• In contrast to the predecessor unit, no separate water cooling of the injector power amplifiers but air convection via cooling fins instead.</li> <li>• No additional component carriers in the control unit for the injector power amplifiers.</li> <li>• Single-processor concept with 150 MHz clock frequency instead of dual-core concept with 66 MHz each.</li> <li>• Significantly increased flash and RAM memory capacities.</li> <li>• Weight reduction by 0.2 kg.</li> </ul>	 <p><i>Engine M 157 N3/10 ME-SFI (ME) control unit</i></p> <p><small>PS4.2-13171-00</small></p>

Claim 1	Corresponding Element in Mercedes-Benz Vehicles <sup>1</sup>
	<p><b>Task</b></p> <p>The engine control unit combines with the sensors and actuators of engine M 157 to form the engine control system. The following systems and functions are controlled and coordinated by the engine control unit according to the input signals:</p> <ul style="list-style-type: none"> <li>• Ignition system</li> <li>• Fuel supply</li> <li>• Injection control</li> <li>• Electronic accelerator</li> <li>• Diagnosis and fault storage</li> <li>• Engine start/stop function</li> <li>• Drive authorization system and immobilizer</li> <li>• Controlled camshaft adjustment</li> <li>• Thermal management</li> <li>• Torque interface</li> <li>• Alternator interface</li> <li>• Oil pressure control</li> <li>• Lambda control</li> <li>• Tank diagnosis</li> <li>• Purging</li> </ul>





**Claim 1** **Corresponding Element in Mercedes-Benz Vehicles<sup>1</sup>**

A1	instrument cluster		
A164	Fuel reserve warning lamp		
A1654	Coolant temperature warning lamp		
A1658	Engine diagnosis indicator lamp		
A1613	Multifunction display		
A29/1	Front knock sensor (left side of engine)		
A29/2	Rear knock sensor (left side of engine)		
A30/1	Front knock sensor (right side of engine)		
A30/2	Rear knock sensor (right side of engine)		
B4/1	Fuel level indicator sensor, left tank half		
B4/2	Fuel level indicator sensor, right tank half		
B4/3	Tank pressure sensor with code (494 USA version)		
B4/7	Fuel pressure sensor		
B4/25	Fuel pressure and temperature sensor		
B6/4	Intake camshaft Hall sensor, left		
B6/5	Intake camshaft Hall sensor, right		
B6/6	Exhaust camshaft Hall sensor, left		
B6/7	Exhaust camshaft Hall sensor, right		
B11/4	Coolant temperature sensor		
B17	Intake air temperature sensor		
B28/4	Pressure sensor downstream of air filter, left cylinder bank		
B28/5	Pressure sensor downstream of air filter, right cylinder bank		
B28/6	Pressure sensor upstream of throttle valve actuator		
B28/7	Pressure sensor downstream of throttle valve actuator		
B37	Accelerator pedal sensor		
B40	Oil sensor (oil level, temperature and quality)		
B64/1	Brake vacuum sensor		
B70	Crankshaft Hall sensor		
G1	On-board electrical system battery		
G2	Alternator		
G3/3	Left O2 sensor upstream of catalytic converter		
G3/4	Right O2 sensor upstream of catalytic converter		
G3/5	Left O2 sensor downstream of catalytic converter		
G3/6	Right O2 sensor downstream of catalytic converter		
L6/1	Left front rpm sensor		
L6/2	Right front rpm sensor		
L6/3	Left rear rpm sensor		
L6/4	Right rear rpm sensor		
M1	Starter		
M3	Fuel pump		
M4/7	Engine and air conditioning electric suction fan with integrated control		
M16/6	Throttle valve actuator		
M44	Charge air cooler circulation pump		
N2/7	Restraint systems control unit		
N3/10	ME-SF [ME] control unit		
N10/1	Front SAM control unit with fuse and relay module		
N10/1AC	Circuit 87 relay, engine		
N10/1AD	Circuit 15 relay		
N10/1AH	Circuit 50 relay, starter		
N10/2	Rear SAM control unit with fuse and relay module		
N10/2KO	Circulation pump relay		
N22/1	A4C [KLA] control unit		
N47-5	ESP control unit		
N51/2	ABC control unit		

(See, e.g., Ex. Mercedes-Benz-1 at 49-51)



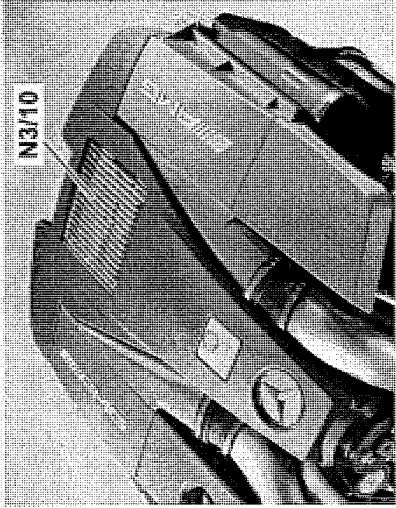

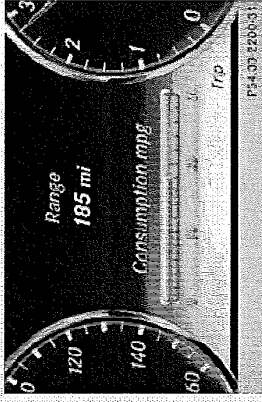

Claim 1	Corresponding Element in Mercedes-Benz Vehicles <sup>1</sup>
	<p><b>Safety fuel shutoff</b></p> <p>A safety fuel shutoff function guarantees road safety and the safety of the occupants.</p> <p>The engine control unit controls the safety fuel shutoff on the basis of the following sensors and signals:</p> <ul style="list-style-type: none"> <li>• Crankshaft Hall sensor, engine rpm</li> <li>• Throttle valve actuator, throttle valve position</li> <li>• Restraint systems control unit, direct crash signal</li> <li>• Restraint systems control unit, indirect crash signal via chassis CAN</li> </ul> <p>The safety fuel shutoff is activated by the engine control unit in the event of mechanical faults in the throttle valve actuator, on the absence of the engine speed signal or after receipt of a crash signal.</p>
<p>1C. a processor subsystem, coupled to each one of said plurality of sensors, to receive data therefrom;</p>	<p>(See, e.g., Ex. Mercedes-Benz-1 at 33).</p> <p>The accused Mercedes-Benz vehicles include a processor subsystem, coupled to each one of said plurality of sensors, to receive data therefrom.</p>
<p>1D. a memory subsystem, coupled to said processor subsystem, said memory</p>	<p>See, e.g., citations for claim elements 1A (describing processor controlled vehicle systems that monitor vehicle system characteristics and operations) and 1B (describing an engine control unit with a processor coupled to sensors that measure system characteristics).</p> <p>On information and belief, the accused Mercedes-Benz vehicles have a memory subsystem, coupled to said processor subsystem, said memory subsystem storing therein a manifold pressure set point, an RPM set point, and present and prior levels for each one of said plurality of sensors.</p>

<b>Corresponding Element in Mercedes-Benz Vehicles</b>	
<p><b>Claim 1</b></p> <p>subsystem storing therein a manifold pressure set point, an RPM set point, and present and prior levels for each one of said plurality of sensors;</p>	<p>For example, the accused Mercedes-Benz vehicles include one or more memories that form a memory subsystem for storing information relating to vehicle system operations:</p> <p><b>ME (motor electronics) control unit</b></p> <p>The MED 17.7.1 engine control builds on experiences with the MED 9 of previous engines. The following features have been implemented in this new engine control MED 17.7.1 in an identical modular housing:</p> <ul style="list-style-type: none"> <li>• Modular design as a standardized control unit for all new V8 engines with direct injection</li> <li>• In contrast to the predecessor unit, no separate water cooling of the injector power amplifiers but air convection via cooling fins instead</li> <li>• No additional component carriers in the control unit for the injector power amplifiers</li> <li>• Single-processor concept with 150 MHz clock frequency instead of dual-core concept with 66 MHz each</li> <li>• Significantly increased flash and RAM memory capacities</li> <li>• Weight reduction by 0.2 kg</li> </ul> <div style="text-align: right;">  <p>PS4.2:13171-00</p> <p><b>Engine M 157</b> N3/10 ME-SFI [ME] control unit</p> </div>

Claim 1	Corresponding Element in Mercedes-Benz Vehicles <sup>1</sup>
	<p data-bbox="347 1066 367 1115">Task</p> <p data-bbox="396 730 509 1115">The engine control unit combines with the sensors and actuators of engine M 157 to form the engine control system. The following systems and functions are controlled and coordinated by the engine control unit according to the input signals:</p> <ul data-bbox="526 762 878 1115" style="list-style-type: none"> <li data-bbox="526 974 545 1115">• Ignition system</li> <li data-bbox="548 1003 568 1115">• Fuel supply</li> <li data-bbox="571 968 591 1115">• Injection control</li> <li data-bbox="594 926 613 1115">• Electronic accelerator</li> <li data-bbox="617 884 636 1115">• Diagnosis and fault storage</li> <li data-bbox="639 890 659 1115">• Engine start/stop function</li> <li data-bbox="662 762 682 1115">• Drive authorization system and immobilizer</li> <li data-bbox="685 848 704 1115">• Controlled camshaft adjustment</li> <li data-bbox="708 926 727 1115">• Thermal management</li> <li data-bbox="730 968 750 1115">• Torque interface</li> <li data-bbox="753 940 773 1115">• Alternator interface</li> <li data-bbox="776 940 795 1115">• Oil pressure control</li> <li data-bbox="799 974 818 1115">• Lambda control</li> <li data-bbox="821 974 841 1115">• Tank diagnosis</li> <li data-bbox="844 1031 863 1115">• Purging</li> </ul> <p data-bbox="932 527 964 1440">(See, e.g., Ex. Mercedes-Benz-1 at 49:51; see also citations for claim elements 1A-C).</p> <p data-bbox="992 464 1138 1440">While the citations above relate specifically to the Mercedes-Benz M157 engine, upon information and belief, Mercedes-Benz's other engines (e.g., the 4-cylinder M270/M274, 6-cylinder M272/M276, 8-cylinder M155/M156/M273/M278/M157/M159 and 12-cylinder M158/M275/M285) have the same or similar memories that form a memory subsystem for storing information relating to vehicle system operations</p>
1E, a fuel overinjection notification circuit coupled to said processor subsystem,	The accused Mercedes-Benz vehicles include a fuel overinjection notification circuit coupled to said processor subsystem, said fuel overinjection notification circuit issuing a notification that excessive fuel is being supplied to said engine of said vehicle.

<p><b>Claim 1</b></p>	<p><b>Corresponding Element in Mercedes-Benz Vehicles<sup>1</sup></b></p>
<p>said fuel overinjection notification circuit issuing a notification that excessive fuel is being supplied to said engine of said vehicle;</p>	<p>For example, the accused Mercedes-Benz vehicles include one or more fuel overinjection notification circuits coupled to said processor subsystem:</p> <div data-bbox="487 735 771 1113" data-label="Image"> </div> <p>The ECO display provides feedback on how economical your driving characteristics are. The ECO display assists you in achieving the most economical driving style for the selected settings and prevailing conditions. Your driving style can significantly influence the vehicle's consumption.</p> <p>The ECO display consists of three bars:</p> <ul style="list-style-type: none"> <li>• Acceleration</li> <li>• Constant</li> <li>• Coasting</li> </ul> <p>The percent value is the average value of the three bars. The three bars and the mean value begin at the value of 50%. A higher percentage indicates a more economical driving style.</p>
<p>(See, e.g., Ex. Mercedes-Benz-2, 2014 S-Class Operator's Manual at 195; Ex. Mercedes-Benz-3,</p>	

Claim 1	Corresponding Element in Mercedes-Benz Vehicles <sup>1</sup>
<p>2014 C-Class Coupe Operator's Manual at 151; Ex. Mercedes-Benz-4, 2014 C-Class Sedan Operator's Manual at 167; Ex. Mercedes-Benz-6, 2014 CLA-Class Sedan Operator's Manual at 157; Ex. Mercedes-Benz-7, 2014 CLS-Class Sedan Operator's Manual at 170; Ex. Mercedes-Benz-8, 2014 E-Class Coupe/Cabriolet Operator's Manual at 185; Ex. Mercedes-Benz-9, 2014 E-Class Sedan/Wagon Operator's Manual at 185; Ex. Mercedes-Benz-11, 2014 GL-Class Operator's Manual at 192; Ex. Mercedes-Benz-12, 2014 GLK-Class Operator's Manual at 167; Ex. Mercedes-Benz-13, 2014 M-Class Operator's Manual at 183; Ex. Mercedes-Benz-14, 2014 SL-Class Operator's Manual at 179; Ex. Mercedes-Benz-15, 2014 SLK-Class Operator's Manual at 163).</p>	<p>Displaying the range and current fuel consumption</p> 

Claim 1	Corresponding Element in Mercedes-Benz Vehicles
<p>1F. an upshift notification circuit coupled to said processor subsystem, said upshift notification circuit issuing a notification that said engine of said vehicle is being operated at an excessive speed;</p>	<ul style="list-style-type: none"> <li>▶ Use  on the steering wheel to call up the list of menus.</li> <li>▶ Press the  or  button on the steering wheel to select the Trip menu.</li> <li>▶ Confirm by pressing <b>OK</b> on the steering wheel.</li> <li>▶ Press the  or  button to select the approximate range and the current fuel consumption (not for AMG vehicles).</li> </ul> <p>The approximate range that can be covered depends on the fuel level and your current driving style. If there is only a small amount of fuel left in the fuel tank, the display shows a vehicle being refueled  instead of the range.</p> <p>(See, e.g., Ex. Mercedes-Benz-2 at 251; Ex. Mercedes-Benz-3 at 192; Ex. Mercedes-Benz-4 at 208; Ex. Mercedes-Benz-5, CL-Class Operator's Manual at 342; Ex. Mercedes-Benz-6 at 198; Ex. Mercedes-Benz-7 at 223; Ex. Mercedes-Benz-8 at 236; Ex. Mercedes-Benz-9 at 242; Ex. Mercedes-Benz-10, G-Class Operator's Manual at 209; Ex. Mercedes-Benz-11 at 276; Ex. Mercedes-Benz-12 at 224; Ex. Mercedes-Benz-13 at 267; Ex. Mercedes-Benz-14 at 230; Ex. Mercedes-Benz-15 at 296; Ex. Mercedes-Benz-16, SL/SL-Class Operator's Manual at 153)</p>
<p>1F. an upshift notification circuit coupled to said processor subsystem, said upshift notification circuit issuing a notification that said engine of said vehicle is being operated at an excessive speed;</p>	<p>The accused Mercedes-Benz vehicles include an upshift notification circuit coupled to said processor subsystem, said upshift notification circuit issuing a notification that said engine of said vehicle is being operated at an excessive speed.</p> <p>For example, the accused Mercedes-Benz vehicles include one or more upshift notification circuits coupled to said processor subsystem, said upshift notification circuit issuing a notification that said engine of said vehicle is being operated at an excessive speed.</p>

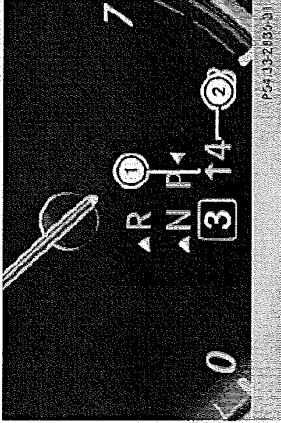

<p><b>Claim 1</b></p>	<p style="text-align: center;"><b>Corresponding Element in Mercedes-Benz Vehicles</b></p> <p style="text-align: center;">Shift recommendation</p>  <p>The gearshift recommendations assist you in adopting an economical driving style. The recommended gear is shown in the multifunction display.</p> <ul style="list-style-type: none"> <li>▶ Shift to recommended gear ② according to gearshift recommendation ① when shown in the multifunction display of the instrument cluster.</li> </ul> <p>(See, e.g., Ex. Mercedes-Benz-2 at 184-85; Ex. Mercedes-Benz-3 at 143-44; Ex. Mercedes-Benz-4 at 159-60; Ex. Mercedes-Benz-6 at 198; Ex. Mercedes-Benz-7 at 161; Ex. Mercedes-Benz-8 at 177-78; Ex. Mercedes-Benz-9 at 173; Ex. Mercedes-Benz-11 at 179-80; Ex. Mercedes-Benz-12 at 157; Ex. Mercedes-Benz-13 at 171; Ex. Mercedes-Benz-14 at 169-171; Ex. Mercedes-Benz-15 at 153-54.)</p> <p>As another example, the accused Mercedes-Benz vehicles include one or more upshift notification circuits coupled to said processor subsystem, said upshift notification circuit issuing a notification that said engine of said vehicle is being operated at an excessive speed.</p>
-----------------------	---

Claim 1	Corresponding Element in Mercedes-Benz Vehicles
	<div data-bbox="365 709 646 1136" data-label="Image"> </div> <div data-bbox="657 940 716 1136" data-label="List-Group"> <ul style="list-style-type: none"> <li>① Gear indicator</li> <li>② Upshift indicator</li> </ul> </div> <div data-bbox="727 709 808 1136" data-label="Text"> <p>Before the engine speed reaches the red area, an upshift indicator will be shown in the multifunction display.</p> </div> <div data-bbox="820 709 1024 1136" data-label="Text"> <p>▶ If the color in the speedometer multifunction display changes to red and the UP display message is shown, shift up a gear using the right-hand steering wheel paddle shifter. The automatic transmission shifts up to the next gear if this is permissible.</p> </div> <div data-bbox="1063 403 1182 1444" data-label="Text"> <p>(See, e.g., Ex. Mercedes-Benz-2 at 185-86; Ex. Mercedes-Benz-3 at 143; Ex. Mercedes-Benz-4 at 159-60; Ex. Mercedes-Benz-6 at 149; Ex. Mercedes-Benz-7 at 163; Ex. Mercedes-Benz-9 at 174; Ex. Mercedes-Benz-10 at 217-18; Ex. Mercedes-Benz-11 at 180; Ex. Mercedes-Benz-13 at 172; Ex. Mercedes-Benz-14 at 172; Ex. Mercedes-Benz-15 at 154; Ex. Mercedes-Benz-16 at 128).</p> </div> <div data-bbox="1214 520 1239 1444" data-label="Text"> <p>As another example, the accused Mercedes-Benz vehicles include one or more upshift</p> </div>

Claim 1	Corresponding Element in Mercedes-Benz Vehicles
<p>1G, said processor subsystem determining, based upon data received from said plurality of sensors, when to activate</p>	<p>notification circuits coupled to said processor subsystem, said upshift notification circuit issuing a notification that said engine of said vehicle is being operated at an excessive speed.</p> <p><b>Shifting gears</b></p> <p>If you pull on the left or right steering wheel paddle shifter, the automatic transmission switches to manual drive program M for a limited amount of time. Depending on which paddle shifter is pulled, the automatic transmission immediately shifts into the next gear down or up, if permitted.</p> <p>▶ <b>To shift up:</b> pull the right-hand steering wheel paddle shifter (&gt; page 183). The automatic transmission shifts up to the next gear.</p> <p>ⓘ if the maximum engine speed on the currently engaged gear is reached and you continue to accelerate, the automatic transmission automatically shifts up in order to prevent engine damage.</p> <p>(See, e.g., Ex. Mercedes-Benz-2 at 184; Ex. Mercedes-Benz-3 at 143; Ex. Mercedes-Benz-4 at 159; Ex. Mercedes-Benz-5 at 284-85; Ex. Mercedes-Benz-6 at 149; Ex. Mercedes-Benz-7 at 161; Ex. Mercedes-Benz-8 at 177; Ex. Mercedes-Benz-9 at 173; Ex. Mercedes-Benz-10 at 151-52; Ex. Mercedes-Benz-11 at 179-80; Ex. Mercedes-Benz-12 at 156; Ex. Mercedes-Benz-13 at 170; Ex. Mercedes-Benz-14 at 169; Ex. Mercedes-Benz-15 at 153.)</p>
<p>1G, said processor subsystem determining, based upon data received from said plurality of sensors, when to activate</p>	<p>On information and belief, the accused Mercedes-Benz vehicles include a processor subsystem that determines based upon data received from said plurality of sensors, when to activate said fuel overinjection circuit and when to activate said upshift notification circuit.</p> <p>See, e.g., citations for elements 1A-1F.</p>

Claim 1	Corresponding Element in Mercedes-Benz Vehicles <sup>1</sup>
said fuel overinjection circuit and when to activate said upshift notification circuit.	

Claim 2	Corresponding Element in Mercedes-Benz Vehicles
2A. Apparatus for optimizing operation of a vehicle according to claim 1 wherein said processor subsystem further comprises:	<p>The accused Mercedes-Benz vehicles include an apparatus for optimizing operation of a vehicle according to claim 1 wherein said processor subsystem further comprises:</p> <p><i>See, e.g.,</i> citations for claim 1.</p>
2B. means for determining when road speed for said vehicle is increasing;	<p>The accused Mercedes-Benz vehicles include a means for determining when road speed for said vehicle is increasing.</p> <p><i>See, e.g.,</i> citations for claim elements IB-1D.</p> <p>To the extent that 35 U.S.C. §112(6) applies to this claim limitation, the structure(s), act(s), or materials(s) that perform the claimed function of “determining when road speed for said vehicle is increasing” are described in, for example, Figures 1 and 2 and associated text of the ’781 patent relating to Road Speed Sensor 18, Memory Subsystem 14, and Processor Subsystem 12.</p>
2C. means for determining when throttle position for said vehicle is increasing; and	<p>The accused Mercedes-Benz vehicles include a means for determining when throttle position for said vehicle is increasing.</p> <p><i>See, e.g.,</i> citations for claim elements IB-1D.</p> <p>To the extent that 35 U.S.C. §112(6) applies to this claim limitation, the structure(s), act(s), or materials(s) that perform the claimed function of “determining when throttle position for said vehicle is increasing” are described in, for example, Figures 1 and 2 and associated text of the ’781 patent relating to Throttle Sensor 24, Memory Subsystem 14, and Processor Subsystem 12.</p>
2D. means for comparing manifold pressure to said manifold pressure set point;	<p>The accused Mercedes-Benz vehicles include a means for comparing manifold pressure to said manifold pressure set point.</p> <p><i>See, e.g.,</i> citations for claim elements IB-1D.</p>

Claim 2	Corresponding Element in Mercedes-Benz Vehicles
<p>2E. said processor subsystem activating said fuel overinjection notification circuit if both road speed and throttle position for said vehicle are increasing and manifold pressure for said vehicle is above said manifold pressure set point.</p>	<p>To the extent that 35 U.S.C. §112(6) applies to this claim limitation, the structure(s), act(s), or materials(s) that perform the claimed function of “comparing manifold pressure to said manifold pressure set point” are described in, for example, Figures 1 and 2 and associated text of the ’781 patent relating to Manifold PSI Sensor 22, Memory Subsystem 14, and Processor Subsystem 12.</p> <p>On information and belief, the accused Mercedes-Benz vehicles include a processor subsystem that activates said fuel overinjection notification circuit if both road speed and throttle position for said vehicle are increasing and manifold pressure for said vehicle is above said manifold pressure set point.</p> <p><i>See, e.g.,</i> citations for claim elements 1E, 1G.</p>

<b>Claim 4</b>	<b>Corresponding Element in Mercedes-Benz Vehicles</b>
<p>4A. Apparatus for optimizing operation of a vehicle according to claim 1 wherein said processor subsystem further comprises:</p>	<p>The accused Mercedes-Benz vehicles include an apparatus for optimizing operation of a vehicle according to claim 1 wherein said processor subsystem further comprises:  <i>See, e.g.,</i> citations for claim 1.</p>
<p>4B. means for determining when road speed for said vehicle is decreasing;</p>	<p>The accused Mercedes-Benz vehicles include a means for determining when road speed for said vehicle is decreasing.  <i>See, e.g.,</i> citations for claim element 2B.</p>
<p>4C. means for determining when throttle position for said vehicle is increasing; and</p>	<p>To the extent that 35 U.S.C. §112(6) applies to this claim limitation, the structure(s), act(s), or materials(s) that perform the claimed function of “determining when road speed for said vehicle is decreasing” are described in, for example, Figures 1 and 2 and associated text of the ’781 patent relating to Road Speed Sensor 18, Memory Subsystem 14, and Processor Subsystem 12.</p>
<p>4D. means for determining when manifold pressure for said vehicle is increasing; and</p>	<p>The accused Mercedes-Benz vehicles include a means for determining when throttle position for said vehicle is increasing.  <i>See, e.g.,</i> citations for claim element 2C.</p> <p>The accused Mercedes-Benz vehicles include a means for determining when manifold pressure for said vehicle is increasing.  <i>See, e.g.,</i> citations for claim elements 1B-1D.</p> <p>To the extent that 35 U.S.C. §112(6) applies to this claim limitation, the structure(s), act(s), or materials(s) that perform the claimed function of “determining when manifold pressure for said vehicle is increasing” are described in, for example, Figures 1 and 2 and associated text of the ’781 patent relating to Manifold PSI Sensor 22, Memory Subsystem 14, and Processor Subsystem 12.</p>

Claim 4	Corresponding Element in Mercedes-Benz Vehicles
<p>4E. means for determining when engine speed for said vehicle is decreasing;</p>	<p>The accused Mercedes-Benz vehicles include a means for determining when engine speed for said vehicle is decreasing. <i>See, e.g.,</i> citations for claim elements 1B-1D.</p> <p>To the extent that 35 U.S.C. §112(6) applies to this claim limitation, the structure(s), act(s), or materials(s) that perform the claimed function of “determining when engine speed for said vehicle is decreasing” are described in, for example, Figures 1 and 2 and associated text of the '781 patent relating to RPM Sensor 20, Memory Subsystem 14, and Processor Subsystem 12.</p>
<p>4F. said processor subsystem activating said fuel overinjection notification circuit if both throttle position and manifold pressure for said vehicle are increasing and road speed and engine speed for said vehicle are decreasing.</p>	<p>On information and belief, the accused Mercedes-Benz vehicles include a processor subsystem that activates said fuel overinjection notification circuit if both throttle position and manifold pressure for said vehicle are increasing and road speed and engine speed for said vehicle are decreasing. <i>See, e.g.,</i> citations for claim elements 1E, 1G.</p>



<b>Claim 5</b>	<b>Corresponding Element in Mercedes-Benz Vehicles</b>
5A. Apparatus for optimizing operation of a vehicle according to claim 1 wherein said processor subsystem further comprises:	The accused Mercedes-Benz vehicles include an apparatus for optimizing operation of a vehicle according to claim 1 wherein said processor subsystem further comprises:  <i>See, e.g., citations for claim 1.</i>
5B. means for determining when road speed for said vehicle is increasing;	The accused Mercedes-Benz vehicles include a means for determining when road speed for said vehicle is increasing.  <i>See, e.g., citations for claim element 2B.</i>
5C. means for determining when throttle position for said vehicle is increasing; and	The accused Mercedes-Benz vehicles include a means for determining when throttle position for said vehicle is increasing.  <i>See, e.g., citations for claim element 2C.</i>
5D. means for comparing manifold pressure to said manifold pressure set point;	The accused Mercedes-Benz vehicles include a means for comparing manifold pressure to said manifold pressure set point.  <i>See, e.g., citations for claim element 2D.</i>
5E. means for comparing engine speed to said RPM set point;	The accused Mercedes-Benz vehicles include a means for comparing engine speed to said RPM set point.  <i>See, e.g., citations for claim elements 1B-1D.</i>
5F. said processor	To the extent that 35 U.S.C. §112(6) applies to this claim limitation, the structure(s), act(s), or materials(s) that perform the claimed function of "determining when engine speed for said vehicle is decreasing" are described in, for example, Figures 1 and 2 and associated text of the '781 patent relating to RPM Sensor 20, Memory Subsystem 14, and Processor Subsystem 12.  On information and belief, the accused Mercedes-Benz vehicles include a processor subsystem

<b>Claim 5</b>	<b>Corresponding Element in Mercedes-Benz Vehicles</b>
<p>subsystem activating said upshift notification circuit if both road speed and throttle position for said vehicle are increasing, manifold pressure for said vehicle is at or below said manifold pressure set point and engine speed for said vehicle is at or above said RPM set point.</p>	<p>that activates said upshift notification circuit if both road speed and throttle position for said vehicle are increasing, manifold pressure for said vehicle is at or below said manifold pressure set point and engine speed for said vehicle is at or above said RPM set point.</p> <p><i>See, e.g., citations for claim elements 1F, 1G.</i></p>

Claim 7	Corresponding Element in Mercedes-Benz Vehicles
7A. Apparatus for optimizing operation of a vehicle, comprising:	The accused Mercedes-Benz vehicles include an apparatus for optimizing operation of a vehicle. <i>See, e.g.,</i> citations for claim 1.
7B. a plurality of sensors coupled to a vehicle having an engine, said plurality of sensors, which collectively monitor operation of said vehicle, including a road speed sensor, a manifold pressure sensor and a throttle position sensor;	The accused Mercedes-Benz vehicles include a plurality of sensors coupled to a vehicle having an engine, said plurality of sensors, which collectively monitor operation of said vehicle, including a road speed sensor, a manifold pressure sensor and a throttle position sensor;  <i>See, e.g.,</i> citations for claim element 1B.
7C. a processor subsystem, coupled to each one of said plurality of sensors, to receive data therefrom;	The accused Mercedes-Benz vehicles include a processor subsystem, coupled to each one of said plurality of sensors, to receive data therefrom.  <i>See, e.g.,</i> citations for claim element 1C.
7D. a memory subsystem, coupled to said processor subsystem, said memory subsystem storing therein a manifold pressure set point and present and prior levels for each one of said plurality of sensors;	The accused Mercedes-Benz vehicles include a memory subsystem, coupled to said processor subsystem, said memory subsystem storing therein a manifold pressure set point and present and prior levels for each one of said plurality of sensors;  <i>See, e.g.,</i> citations for claim element 1D.
7E. a fuel overinjection notification circuit coupled to said processor subsystem, said fuel overinjection notification circuit issuing a notification that excessive fuel is being supplied to said engine of said vehicle;	The accused Mercedes-Benz vehicles include a fuel overinjection notification circuit coupled to said processor subsystem, said fuel overinjection notification circuit issuing a notification that excessive fuel is being supplied to said engine of said vehicle;

<p><b>Claim 7</b> notification circuit issuing a notification that excessive fuel is being supplied to said engine of said vehicle;</p>	<p><b>Corresponding Element in Mercedes-Benz Vehicles</b> <i>See, e.g., citations for claim element 1E.</i></p>
<p>7F. a downshift notification circuit coupled to said processor subsystem, said downshift notification circuit issuing a notification that said engine of said vehicle is being operated at an insufficient engine speed;</p> <p>and</p>	<p>The accused Mercedes-Benz vehicles include a downshift notification circuit coupled to said processor subsystem, said downshift notification circuit issuing a notification that said engine of said vehicle is being operated at an insufficient engine speed.</p> <p>For example, the accused Mercedes-Benz vehicles include one or more downshift notification circuits coupled to said processor subsystem, said downshift notification circuit issuing a notification that said engine of said vehicle is being operated at an insufficient speed.</p>

Shift recommendation

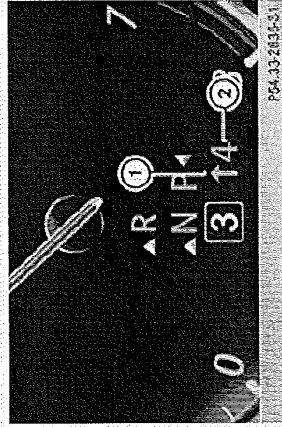

Claim 7	Corresponding Element in Mercedes-Benz Vehicles
	<p>The gearshift recommendations assist you in adopting an economical driving style. The recommended gear is shown in the multifunction display.</p> <ul style="list-style-type: none"> <li>▶ Shift to recommended gear ② according to gearshift recommendation ① when shown in the multifunction display of the instrument cluster.</li> </ul>
	<p>(See, e.g., Ex. Mercedes-Benz-2 at 184-85; Ex. Mercedes-Benz-3 at 143-44; Ex. Mercedes-Benz-4 at 159-60; Ex. Mercedes-Benz-6 at 198; Ex. Mercedes-Benz-7 at 161; Ex. Mercedes-Benz-8 at 177-78; Ex. Mercedes-Benz-9 at 173; Ex. Mercedes-Benz-11 at 179-80; Ex. Mercedes-Benz-12 at 157; Ex. Mercedes-Benz-13 at 171; Ex. Mercedes-Benz-14 at 169-171; Ex. Mercedes-Benz-15 at 153-54.)</p>
	<p>As another example, the accused Mercedes-Benz vehicles include one or more downshift notification circuits coupled to said processor subsystem, said downshift notification circuit issuing a notification that said engine of said vehicle is being operated at an insufficient speed.</p> <p><b>Shifting gears</b></p> <p>If you pull on the left or right steering wheel paddle shifter, the automatic transmission switches to manual drive program M for a limited amount of time. Depending on which paddle shifter is pulled, the automatic transmission immediately shifts into the next gear down or up, if permitted.</p>

Claim 7	Corresponding Element in Mercedes-Benz Vehicles
<p>7G. said processor subsystem determining, based upon data received from said plurality of sensors, when to activate said fuel overinjection circuit and when to activate said downshift notification circuit.</p>	<p><b>1</b> <b>AMG vehicles:</b> the automatic transmission will not shift up to the next gear when the engine speed is very low.</p> <p>▶ <b>To shift down:</b> pull on the left-hand steering wheel paddle shifter (&gt; page 183). The automatic transmission shifts down to the next gear.</p> <p><b>2</b> if the engine exceeds the maximum engine speed when shifting down, the automatic transmission protects against engine damage by not shifting down.</p> <p><b>3</b> Automatic down shifting occurs when coasting.</p> <p>(See, e.g., Ex. Mercedes-Benz-2 at 184; Ex. Mercedes-Benz-3 at 144; Ex. Mercedes-Benz-4 at 160; Ex. Mercedes-Benz-5 at 285; Ex. Mercedes-Benz-6 at 149; Ex. Mercedes-Benz-7 at 161; Ex. Mercedes-Benz-8 at 177; Ex. Mercedes-Benz-9 at 173; Ex. Mercedes-Benz-10 at 152; Ex. Mercedes-Benz-11 at 178-80; Ex. Mercedes-Benz-12 at 156; Ex. Mercedes-Benz-13 at 170; Ex. Mercedes-Benz-14 at 169; Ex. Mercedes-Benz-15 at 153; Ex. Mercedes-Benz-15 at 128.)</p> <p>On information and belief, the accused Mercedes-Benz vehicles include a processor subsystem that determines, based upon data received from said plurality of sensors, when to activate said fuel overinjection circuit and when to activate said downshift notification circuit.</p> <p>See, e.g., citations for elements 1G, 7F.</p>

Claim 8	Corresponding Element in Mercedes-Benz Vehicles
8A. Apparatus for optimizing operation of a vehicle according to claim 7 wherein said processor subsystem further comprises:	The accused Mercedes-Benz vehicles include an apparatus for optimizing operation of a vehicle according to claim 7 wherein said processor subsystem further comprises:  <i>See, e.g., citations for claim 1.</i>
8B. means for determining when road speed for said vehicle is increasing;	The accused Mercedes-Benz vehicles include a means for determining when road speed for said vehicle is increasing.  <i>See, e.g., citations for claim element 2B.</i>
8C. means for determining when throttle position for said vehicle is increasing; and	The accused Mercedes-Benz vehicles include a means for determining when throttle position for said vehicle is increasing.  <i>See, e.g., citations for claim element 2C.</i>
8D. means for comparing manifold pressure to said manifold pressure set point;	The accused Mercedes-Benz vehicles include a means for comparing manifold pressure to said manifold pressure set point.  <i>See, e.g., citations for claim element 2D.</i>
8E. said processor subsystem activating said fuel overinjection notification circuit if both road speed and throttle position for said vehicle are increasing and manifold pressure for said vehicle is above said manifold pressure set point.	On information and belief, the accused Mercedes-Benz vehicles include a processor subsystem that activates said fuel overinjection notification circuit if both road speed and throttle position for said vehicle are increasing and manifold pressure for said vehicle is above said manifold pressure set point.  <i>See, e.g., citations for claim element 2E.</i>

<b>Claim 10</b>	<b>Corresponding Element in Mercedes-Benz Vehicles</b>
10A. Apparatus for optimizing operation of a vehicle according to claim 7 wherein said processor subsystem further comprises:	The accused Mercedes-Benz vehicles include an apparatus for optimizing operation of a vehicle according to claim 7 wherein said processor subsystem further comprises:  <i>See, e.g., citations for claim element 1.</i>
10B. means for determining when road speed for said vehicle is decreasing;	The accused Mercedes-Benz vehicles include a means for determining when road speed for said vehicle is decreasing.  <i>See, e.g., citations for claim element 4B.</i>
10C. means for determining when throttle position for said vehicle is increasing; and	The accused Mercedes-Benz vehicles include a means for determining when throttle position for said vehicle is increasing.  <i>See, e.g., citations for claim element 2C.</i>
10D. means for determining when manifold pressure for said vehicle is increasing; and	The accused Mercedes-Benz vehicles include a means for determining when manifold pressure for said vehicle is increasing.  <i>See, e.g., citations for claim element 4D.</i>
10E. means for determining when engine speed for said vehicle is decreasing;	The accused Mercedes-Benz vehicles include a means for determining when engine speed for said vehicle is decreasing.  <i>See, e.g., citations for claim element 4E.</i>
10F. said processor subsystem activating said downshift notification circuit if both road speed	On information and belief, the accused Mercedes-Benz vehicles include a processor subsystem that activates said downshift notification circuit if both road speed and engine speed are decreasing and both throttle position and manifold pressure for said vehicle are increasing.



Claim 10	Corresponding Element in Mercedes-Benz Vehicles
<p>and engine speed are decreasing and both throttle position and manifold pressure for said vehicle are increasing.</p>	<p>See, e.g., citations for claim elements IG, 7F.</p>

Claim 12	Corresponding Element in Mercedes-Benz Vehicles
12A. Apparatus for optimizing operation of a vehicle according to claim 7 wherein said processor subsystem further comprises:	The accused Mercedes-Benz vehicles include an apparatus for optimizing operation of a vehicle according to claim 7 wherein said processor subsystem further comprises:  <i>See, e.g., citations for claim 1.</i>
12B. means for determining when road speed for said vehicle is decreasing;	The accused Mercedes-Benz vehicles include a means for determining when road speed for said vehicle is decreasing.  <i>See, e.g., citations for claim element 4B.</i>
12C. means for determining when throttle position for said vehicle is increasing; and	The accused Mercedes-Benz vehicles include a means for determining when throttle position for said vehicle is increasing.  <i>See, e.g., citations for claim element 2C.</i>
12D. means for determining when manifold pressure for said vehicle is increasing; and	The accused Mercedes-Benz vehicles include a means for determining when manifold pressure for said vehicle is increasing.  <i>See, e.g., citations for claim element 4D.</i>
12E. means for determining when engine speed for said vehicle is decreasing;	The accused Mercedes-Benz vehicles include a means for determining when engine speed for said vehicle is decreasing.  <i>See, e.g., citations for claim element 4E.</i>
12F. said processor subsystem activating said fuel overinjection notification circuit if both throttle position and	On information and belief, the accused Mercedes-Benz vehicles include a processor subsystem that activates said fuel overinjection notification circuit if both throttle position and manifold pressure for said vehicle are increasing and road speed and engine speed for said vehicle are decreasing.

<b>Claim 12</b>	<b>Corresponding Element in Mercedes-Benz Vehicles</b>
<p>manifold pressure for said vehicle are increasing and road speed and engine speed for said vehicle are decreasing.</p>	<p>See, e.g., citations for claim elements 1E, 1G.</p>

Claim 13	Corresponding Element in Mercedes-Benz Vehicles
13A. Apparatus for optimizing operation of a vehicle, comprising:	The accused Mercedes-Benz vehicles include an apparatus for optimizing operation of a vehicle.
13B. a plurality of sensors coupled to a vehicle having an engine, said plurality of sensors, which collectively monitor operation of said vehicle, including a road speed sensor, an engine speed sensor, a manifold pressure sensor and a throttle position sensor;	<p><i>See, e.g.,</i> citations for claim 1.</p> <p>The accused Mercedes-Benz vehicles include a plurality of sensors coupled to the vehicle having an engine, said plurality of sensors, which collectively monitor operation of said vehicle, including a road speed sensor, an engine speed sensor, a manifold pressure sensor and a throttle position sensor</p> <p><i>See, e.g.,</i> citations for claim element 1B.</p>
13C. a processor subsystem, coupled to each one of said plurality of sensors, to receive data therefrom;	<p>The accused Mercedes-Benz vehicles include a processor subsystem, coupled to each one of said plurality of sensors, to receive data therefrom.</p> <p><i>See, e.g.,</i> citations for claim element 1C.</p>
13D. a memory subsystem, coupled to said processor subsystem, said memory subsystem storing therein a manifold pressure set point, an engine speed set point, and present and prior levels for each one of said plurality of sensors;	<p>The accused Mercedes-Benz vehicles have a memory subsystem, coupled to said processor subsystem, said memory subsystem storing therein a manifold pressure set point, an engine speed set point, and present and prior levels for each one of said plurality of sensors.</p> <p><i>See, e.g.,</i> citations for claim element 1D.</p>
13E. a fuel overinjection notification circuit coupled to said processor subsystem,	The accused Mercedes-Benz vehicles include a fuel overinjection notification circuit coupled to said processor subsystem, said fuel overinjection notification circuit issuing a notification that excessive fuel is being supplied to said engine of said vehicle.

Claim 13	Corresponding Element in Mercedes-Benz Vehicles
<p>said fuel overinjection notification circuit issuing a notification that excessive fuel is being supplied to said engine of said vehicle;</p>	<p><i>See, e.g.,</i> citations for claim element 1E.</p>
<p>13F. an upshift notification circuit coupled to said processor subsystem, said upshift notification circuit issuing a notification that said engine of said vehicle is being operated at an excessive speed;</p>	<p>The accused Mercedes-Benz vehicles include an upshift notification circuit coupled to said processor subsystem, said upshift notification circuit issuing a notification that said engine of said vehicle is being operated at an excessive speed.</p> <p><i>See, e.g.,</i> citations for claim element 1F.</p>
<p>13G. a downshift notification circuit coupled to said processor subsystem, said downshift notification circuit issuing a notification that said engine of said vehicle is being operated at an insufficient engine speed; and</p>	<p>The accused Mercedes-Benz vehicles include a downshift notification circuit coupled to said processor subsystem, said downshift notification circuit issuing a notification that said engine of said vehicle is being operated at an insufficient engine speed; and</p> <p><i>See, e.g.,</i> citations for claim element 7F.</p>
<p>13H. said processor subsystem determining, based upon data received from said plurality of sensors, when to activate said fuel overinjection circuit, said upshift notification circuit and said</p>	<p>The accused Mercedes-Benz vehicles include a processor subsystem that determines based upon data received from said plurality of sensors, when to activate said fuel overinjection circuit, said upshift notification circuit and said downshift notification circuit.</p> <p><i>See, e.g.,</i> citations for claim element 1G.</p>

<p><b>Claim 13</b></p> <p>downshift notification circuit.</p>	<p><b>Corresponding Element in Mercedes-Benz Vehicles</b></p>
---	---

Claim 15	Corresponding Element in Mercedes-Benz Vehicles
15A. Apparatus for optimizing operation of a vehicle according to claim 13 wherein said processor subsystem further comprises:	The accused Mercedes-Benz vehicles include an apparatus for optimizing operation of a vehicle according to claim 13 wherein said processor subsystem further comprises:  <i>See, e.g.,</i> citations for claim 1.
15B. means for determining when road speed for said vehicle is increasing or decreasing;	The accused Mercedes-Benz vehicles include a means for determining when road speed for said vehicle is increasing or decreasing.  <i>See, e.g.,</i> citations for claim element 2B.  To the extent that 35 U.S.C. §112(6) applies to this claim limitation, the structure(s), act(s), or materials(s) that perform the claimed function of “determining when road speed for said vehicle is increasing or decreasing” are described in, for example, Figures 1 and 2 and associated text of the '781 patent relating to Road Speed Sensor 18, Memory Subsystem 14, and Processor Subsystem 12.
15C. means for determining when throttle position for said vehicle is increasing;	The accused Mercedes-Benz vehicles include a means for determining when throttle position for said vehicle is increasing.  <i>See, e.g.,</i> citations for claim element 2C.
15D. means for comparing manifold pressure to said manifold pressure set point;	The accused Mercedes-Benz vehicles include a means for comparing manifold pressure to said manifold pressure set point.  <i>See, e.g.,</i> citations for claim element 2D.
15E. means for comparing engine speed to said RPM set point;	The accused Mercedes-Benz vehicles include a means for comparing engine speed to said RPM set point.  <i>See, e.g.,</i> citations for claim element 5E.

Claim 15	Corresponding Element in Mercedes-Benz Vehicles
15F. means for determining when manifold pressure is increasing.	The accused Mercedes-Benz vehicles include a means for determining when manifold pressure is increasing. <i>See, e.g.</i> , citations for claim element 4D.
15G. means for determining when engine speed is increasing or decreasing;	The accused Mercedes-Benz vehicles include a means for determining when engine speed is increasing or decreasing. <i>See, e.g.</i> , citations for claim element 4E.  To the extent that 35 U.S.C. §112(6) applies to this claim limitation, the structure(s), act(s), or materials(s) that perform the claimed function of “determining when engine speed for said vehicle is increasing or decreasing” are described in, for example, Figures 1 and 2 and associated text of the '781 patent relating to RPM Sensor 20, Memory Subsystem 14, and Processor Subsystem 12.
15H. said processor subsystem activating said fuel overinjection notification circuit if both road speed and throttle position for said vehicle are increasing and manifold pressure for said vehicle is above said manifold pressure set or if both throttle position and manifold pressure for said vehicle are increasing and road speed and engine speed for said vehicle are decreasing.	On information and belief, the accused Mercedes-Benz vehicles include a processor subsystem that activates said fuel overinjection notification circuit if both road speed and throttle position for said vehicle are increasing and manifold pressure for said vehicle is above said manifold pressure set or if both throttle position and manifold pressure for said vehicle are increasing and road speed and engine speed for said vehicle are decreasing.  <i>See, e.g.</i> , citations for claim elements 1E, 1G.



Claim 15	Corresponding Element in Mercedes-Benz Vehicles
<p>15I. said processor subsystem activating said upshift notification circuit if both road speed and throttle position for said vehicle are increasing, manifold pressure for said vehicle is at or below said manifold pressure set point and engine speed for said vehicle is at or above said RPM set point; and</p>	<p>On information and belief, the accused Mercedes-Benz vehicles include a processor subsystem that activates said upshift notification circuit if both road speed and throttle position for said vehicle are increasing, manifold pressure for said vehicle is at or below said manifold pressure set point and engine speed for said vehicle is at or above said RPM set point.</p> <p><i>See, e.g.</i>, citations for claim elements 1F, 1G.</p>
<p>15J. said processor subsystem activating said downshift notification circuit if both road speed and engine speed are decreasing and both throttle position and manifold pressure for said vehicle are increasing.</p>	<p>On information and belief, the accused Mercedes-Benz vehicles include a processor subsystem that activates said downshift notification circuit if both road speed and engine speed are decreasing and both throttle position and manifold pressure for said vehicle are increasing.</p> <p><i>See, e.g.</i>, citations for claim element 10F.</p>

<b>Claim 17</b>	<b>Corresponding Element in Mercedes-Benz Vehicles</b>
<p>17A. Apparatus for optimizing operation of a vehicle, comprising:</p>	<p>The accused Mercedes-Benz vehicles include an apparatus for optimizing operation of a vehicle.  See, e.g., citations for claim 1.</p>
<p>17B. a radar detector, said radar detector determining a distance separating a vehicle having an engine and an object in front of said vehicle;</p>	<p>The accused Mercedes-Benz vehicles include a radar detector that determines a distance separating a vehicle having an engine and another object in front of the accused vehicles.  For example, the accused Mercedes-Benz vehicles include one or more systems with radar detectors that determine a distance separating a vehicle having an engine and another object in front of the accused vehicles.  17B1. PRE-SAFE/PRE-SAFE PLUS:</p>
	<p><b>PRE-SAFE® PLUS (anticipatory occupant protection system PLUS)</b></p> <p><b>General information</b></p> <p>PRE-SAFE® PLUS is only available in vehicles with the Driving Assistance package.  Using the radar sensor system, PRE-SAFE® PLUS is able to detect that a head-on or rear-end collision is imminent. In certain hazardous situations, PRE-SAFE® PLUS takes pre-emptive measures to protect the vehicle occupants.</p>

<p><b>Claim 17</b></p>	<p style="text-align: center;"><b>Corresponding Element in Mercedes-Benz Vehicles</b></p> <p>(See, e.g., Ex. Mercedes-Benz-2 at 56; Ex. Mercedes-Benz-3 at 50; Ex. Mercedes-Benz-4 at 52; Ex. Mercedes-Benz-5 at 55; Ex. Mercedes-Benz-7 at 54-55; Ex. Mercedes-Benz-8 at 55-56; Ex. Mercedes-Benz-9 at 54-55; Ex. Mercedes-Benz-11 at 54-55; Ex. Mercedes-Benz-13 at 54; Ex. Mercedes-Benz-14 at 61; Ex. Mercedes-Benz-15 at 50).</p> <p>17B2. BAS PLUS (Brake Assist System PLUS):</p>
------------------------	--

<p><b>Claim 17</b></p>	<p style="text-align: center;"><b>Corresponding Element in Mercedes-Benz Vehicles</b></p> <p><b>BAS PLUS (Brake Assist System PLUS) with Cross-Traffic Assist</b></p> <p><b>General information</b></p> <p>🔔 Observe the "important safety notes" section (→ page 70).</p> <p>BAS PLUS is only available on vehicles with the Driving Assistance package.</p> <p>For BAS PLUS to assist you when driving, the radar sensor system and the camera system must be operational.</p> <p>With the help of a sensor system and a camera system, BAS PLUS can detect obstacles:</p> <ul style="list-style-type: none"> <li>• that are in the path of your vehicle for an extended period of time</li> <li>• that cross the path of your vehicle</li> </ul> <p>In addition, pedestrians in the path of your vehicle can be detected.</p> <p>BAS PLUS detects pedestrians by using typical characteristics such as the body contours and posture of a person standing upright.</p> <p>(See, e.g., Ex. Mercedes-Benz-2 at 72; Ex. Mercedes-Benz-3 at 63; Ex. Mercedes-Benz-4 at 66; Ex. Mercedes-Benz-5 at 66; Ex. Mercedes-Benz-7 at 67; Ex. Mercedes-Benz-8 at 70; Ex. Mercedes-Benz-9 at 68; Ex. Mercedes-Benz-11 at 68; Ex. Mercedes-Benz-12 at 68; Ex. Mercedes-Benz-13 at 68; Ex. Mercedes-Benz-14 at 72; Ex. Mercedes-Benz-15 at 60; Ex.</p>
------------------------	---

**Claim 17**

**Corresponding Element in Mercedes-Benz Vehicles**

Mercedes-Benz-16 at 72).

**17B3. COLLISION PREVENTION ASSIST/Distance Warning Function:**

**Function**

► **To activate/deactivate:** activate or deactivate the distance warning function in the on-board computer (→ page 261).

If the distance warning function is not activated, the  symbol appears in the assistance graphics display.

The distance warning function can help you to minimize the risk of a front-end collision with a vehicle ahead or reduce the effects of such a collision. If the distance warning function detects that there is a risk of a collision, you will be warned visually and acoustically. The distance warning function cannot prevent a collision without your intervention.

**Claim 17**

**Corresponding Element in Mercedes-Benz Vehicles**

Starting at a speed of around 4 mph (7 km/h), the distance warning function warns you if you rapidly approach a vehicle in front. An intermittent warning tone will then sound and the [A] distance warning lamp will light up in the instrument cluster.

▶ Brake immediately in order to increase the distance from the vehicle in front.

or

▶ Take evasive action, provided it is safe to do so.

Due to the nature of the system, particularly complicated but non-critical driving conditions may also cause the system to display a warning.

With the help of the radar sensor system, the distance warning function can detect obstacles that are in the path of your vehicle for an extended period of time.

(See, e.g., Ex. Mercedes-Benz-2 at 74; Ex. Mercedes-Benz-6 at 62-64; Ex. Mercedes-Benz-8 at 70-71; Ex. Mercedes-Benz-9 at 70-71; Ex. Mercedes-Benz-11 at 69-70; Ex. Mercedes-Benz-13 at 69-70).

17B4. COLLISION PREVENTION ASSIST/Adaptive Brake Assist.

Claim 17	Corresponding Element in Mercedes-Benz Vehicles
	<p>Adaptive Brake Assist aids you in braking during hazardous situations at speeds above 4 mph (7 km/h) and uses the radar sensor system to evaluate the traffic situation.</p> <p>With the help of Adaptive Brake Assist, the distance warning signal can detect obstacles that are in the path of your vehicle for an extended period of time.</p> <p>Should you approach an obstacle and Adaptive Brake Assist has detected a risk of collision, Adaptive Brake Assist calculates the braking force necessary to avoid a rear-end collision. Should you apply the brakes vigorously, Adaptive Brake Assist will automatically increase the braking force to a level suitable for the traffic conditions.</p> <p>(See, e.g., Ex. Mercedes-Benz-2 at 75; Ex. Mercedes-Benz-6 at 64-66; Ex. Mercedes-Benz-8 at 71-72; Ex. Mercedes-Benz-9 at 71-72; Ex. Mercedes-Benz-11 at 71-72; Ex. Mercedes-Benz-13 at 70-71).</p> <p>17B5: PRE-SAFE Brake:</p>

**Claim 17**

**Corresponding Element in Mercedes-Benz Vehicles**

**PRE-SAFE® Brake**

**General information**

ⓘ Pay attention to the important safety notes in the "Driving safety systems" section (▷ page 70).

PRE-SAFE® Brake is only available for vehicles with the Driving Assistance package. For PRE-SAFE® Brake to assist you when driving, the radar sensor system and the camera system must be switched on and be operational.

With the help of the radar sensor system and the camera system, PRE-SAFE® Brake can detect obstacles that are in front of your vehicle for an extended period of time.

In addition, pedestrians in the path of your vehicle can be detected.

(See, e.g., Ex. Mercedes-Benz-2 at 78; Ex. Mercedes-Benz-3 at 67; Ex. Mercedes-Benz-4 at 71; Ex. Mercedes-Benz-5 at 68; Ex. Mercedes-Benz-7 at 72; Ex. Mercedes-Benz-8 at 76-77; Ex. Mercedes-Benz-9 at 76-77; Ex. Mercedes-Benz-11 at 75; Ex. Mercedes-Benz-12 at 72; Ex. Mercedes-Benz-13 at 74; Ex. Mercedes-Benz-14 at 77; Ex. Mercedes-Benz-15 at 65; Ex. Mercedes-Benz-16 at 77).

17B6. DISTRONIC PLUS: