

FIGURE 29.3 Nodes and street segments of vector encoded map.

By considering each road or street as a series of straight lines and each intersection as a node, a map may be viewed as a set of interrelated nodes, lines, and enclosed areas as illustrated by Fig. 29.3.

Nodes may be identified by their coordinates (e.g., latitude and longitude). Additional nodes “shape points” are positioned along curves where the link between two intersections is not a straight line. Curves are thus approximated by a series of vectors connecting shape points, whereas a single vector directly connects the node points representing successive intersections if there are no curves in the connecting road segment.

The X-Y coordinates of node points may be encoded from maps or aerial photographs. The classic approach uses special work stations which record the coordinates of a given point when the cross hair of an instrument is placed over the point and a button pressed. This process has been automated in varying degrees. In some cases, the printed map is scanned to obtain a matrix image, which is then converted to vector form by software.

Various combinations of attributes associated with the encoded road network are included in digital map databases. Of particular importance are roadway classifications, street names, and address ranges between nodes. Map databases used with systems that give turn-by-turn route guidance also require traffic attributes such as turn restrictions by time of day and delineation of one-way streets. Directory and yellow pages information for selecting attractions, parking, restaurants, hotels, emergency facilities, etc., are commonly included.

### 29.2.4 Map Matching

Map matching is a type of artificial intelligence process used in virtually all vehicle navigation and route guidance systems that recognize a vehicle’s location by matching the pattern of its apparent path (as approximated by dead reckoning and/or radiopositioning) with the road patterns of digital maps stored in computer memory. Most map-matching software may be classified as either semideterministic or probabilistic.<sup>4</sup>

**Semideterministic.** This approach assumes that the equipped vehicle is essentially confined to a defined route or road network, and is designed to determine where the vehicle is along a route or within the road network. The concept may be illustrated by tracking the location of a vehicle over the simple route shown in Fig. 29.4a which defines a route from node A through nodes B, C, D, E and thence back to A in terms of instantaneous direction ( $\phi$ ) of travel versus cumulative distance ( $L$ ) from the beginning as shown in Fig. 29.4b. Locations of nodes where direction changes occur (or could occur) are thus defined in terms of distance  $L$ . The solid line gives heading versus distance corresponding to the simple route. Alternative routes emanating from each node are indicated by dashed lines.

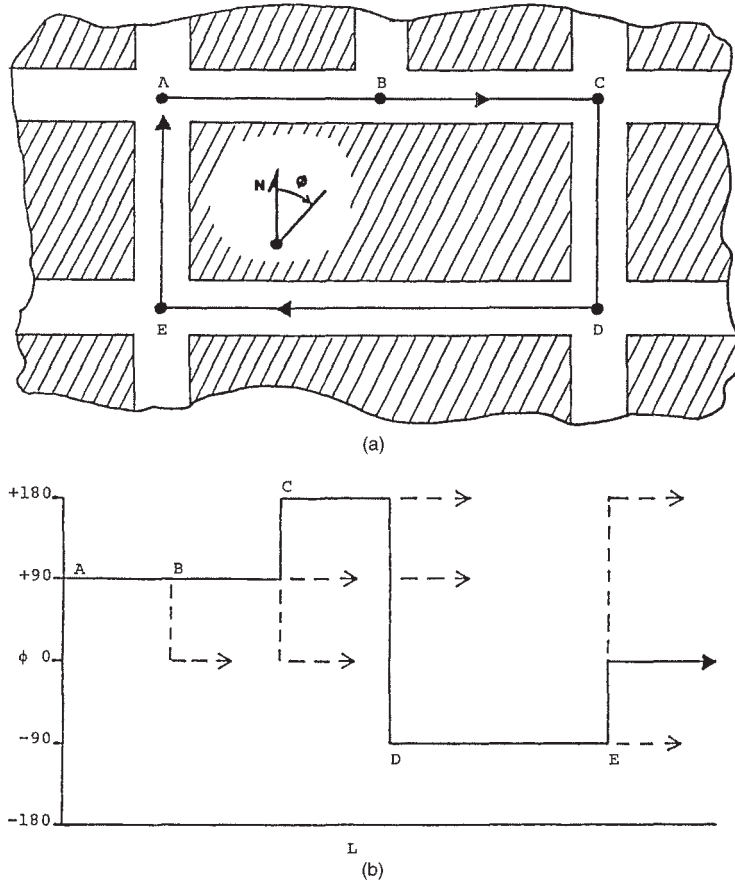

FIGURE 29.4 Simplified route and vector model.<sup>4</sup>

Figure 29.5 shows the kernel of a semideterministic algorithm in highly simplified form. Once initialized at a starting location ( $\phi = 90^\circ$  and  $L = 0$  at Node A in the example), the algorithm, in effect, repeatedly asks, "Is the vehicle still on the route?" and "What is the present location along the route?" The vehicle is confirmed on the route if certain tests are satisfied. The location along the route is estimated by odometry, and error in the estimate is automatically removed at each node where it is determined that an expected change in heading actually occurs.

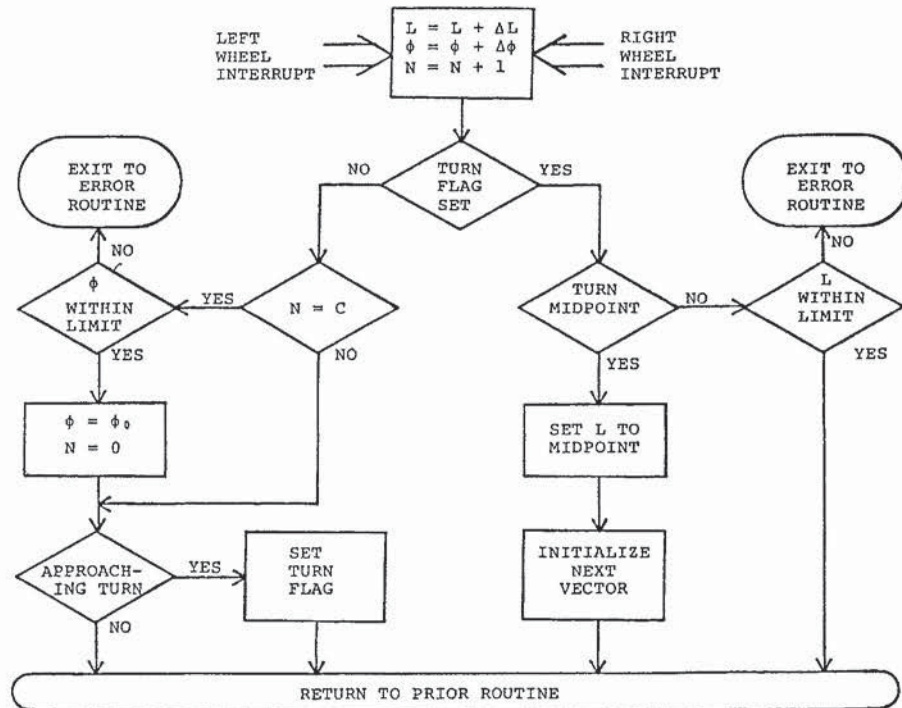

FIGURE 29.5 Simplified map-matching algorithm.<sup>4</sup>

The map-matching algorithm is driven by interrupts from differential odometer sensors installed on left and right wheels. The distance  $L$  from the beginning of a route segment is updated by adding an increment  $\Delta L$  for each left wheel interrupt, and the vehicle heading  $\phi$  is updated by adding an increment  $\Delta\phi$  calculated from the difference in travel by the left and right wheels since the count  $N$  was last set to 0. As explained below, the  $N$  counter controls monitoring for unexpected heading changes occurring over relatively short distances.

Unless the turn flag is set to denote that the vehicle is approaching a distance  $L$  where a heading change should occur, count  $N$  is checked after each interrupt to determine if it has reached a limit  $C$  corresponding to an arbitrary amount of travel on the order of several meters. When the count limit  $C$  is reached, a test is made to determine if  $\phi$  is within arbitrary limits (say  $\pm 5$  degrees to allow for lane changes, slight road curvature, etc.). If so,  $\phi$  is reset to  $\phi_0$  (the direction of the vector being traveled) and  $N$  is set to 0 to start another cycle of monitoring for unexpected heading changes.

In addition to verifying that the vehicle stays on the route between nodes, this process removes error in measured vehicle heading that accumulates while  $0 < N < C$ . If the preceding test finds  $\phi$  to be outside the limits, the vehicle is presumed to have turned off the route (perhaps into an unmapped driveway or parking lot) and other routines are called into play. For example, route recovery instructions could be issued.

When the vehicle approaches within an arbitrary distance (e.g., 75 m) of a node where a change in vehicle heading should occur, the turn flag is set and a route guidance instruction is issued, giving the direction of the turn and, if appropriate, the name of the next road. The algorithm then monitors for changes in  $\phi$  to confirm that the midpoint of the expected turn is reached within an arbitrary limit (e.g., 10 m) of the value of  $L$  specified for the node, and afterwards to confirm that the turn is completed.

Upon reaching the midpoint, the current value of  $L$  is adjusted to that specified, thus removing any error in the measured distance accumulated since the last turn. If the expected turn is not confirmed within the allowed limits on distance  $L$ , the vehicle is assumed to have missed the turn or to have taken an alternate turn (see dashed lines in Fig. 29.4b) and other routines may be called to identify the alternate route taken from the node.

The semideterministic algorithm concept outlined here may be extended to tracking a vehicle's location as it moves over arbitrary routes within a road network rather than following a preplanned route. As long as the vehicle stays on roadways defined by a vector-encoded digital map, the vehicle must exit each node via some vector. Thus, a map-matching algorithm can identify successive vectors traveled by measuring the direction of vehicle travel as it leaves each node and comparing the vehicle direction with that of various vectors emanating from the node.

**Probabilistic.** An enhanced type of map-matching algorithm is required for tracking vehicles not presumed to be constrained to the roads. When the vehicle departs from the defined route or road network (e.g., into a parking lot), or appears to depart as a result of dead-reckoning error, the routine repeatedly compares the vehicle's dead-reckoned coordinates with those of the links surrounding the off-road area which encompasses the vehicle location in order to recognize where the vehicle returns to the road network. Unlike while traveling on defined roadways, map-matching adjustments do not prevent accumulation of dead-reckoning error. Thus, depending upon the distance traveled off road and the accuracy of the dead-reckoning sensors, there may be considerable uncertainty in vehicle coordinates, which could produce misleading conclusions when tested against the surrounding links.

Probabilistic map-matching algorithms minimize the potential of off-road errors by maintaining a running estimate of uncertainty in dead-reckoned location, which is considered in determining whether the vehicle is on a street. The estimate of location uncertainty is reduced each time it is deemed that the vehicle is on a street, but the uncertainty resumes growth in proportion to further vehicle travel until the next match occurs. Thus, a probabilistic algorithm repeatedly asks, "Where is the vehicle?," with no a priori presumption that it is on a road.

### 29.3 EXAMPLES OF NAVIGATION SYSTEMS

---

Figure 29.6 is a block diagram showing the major elements of a typical automobile navigation system. Distance and heading (or heading change) sensors are almost invariably included for dead-reckoning calculations which, in combination with map matching, form the basic platform for keeping track of vehicle location. However, dead reckoning with map matching has the drawback of occasionally failing due to dead-reckoning anomalies, extensive travel off mapped roads, ferry crossings, etc.

The *location sensor* indicated by dashed lines in Fig. 29.6 is an optional means of providing absolute location to avoid occasional manual reinitialization when dead reckoning with map matching fails. Although proximity beacons serve to update vehicle location in a few systems (particularly those that also use proximity beacons for data communication), most state-of-the-art systems use GPS receivers instead.

The recent evolution and present trends of automobile navigation and route guidance systems are illustrated by the following examples.

#### 29.3.1 Etak Navigator™/Bosch Travelpilot™

The Etak, Inc. Navigator™ introduced in California in the mid-1980s was the first commercially available automobile navigation system to include digitized road maps, dead reckoning with



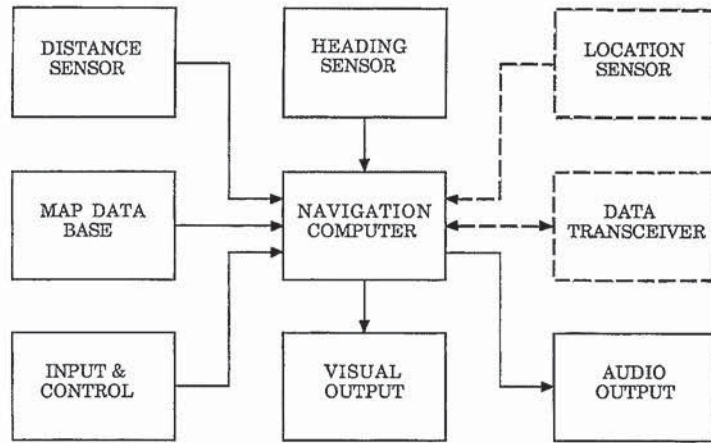

FIGURE 29.6 Typical components and subsystems of vehicle navigation system.

map matching, and an electronic map display. It used a flux-gate compass and differential odometer for dead reckoning. The equivalent of two printed city street maps were vector encoded and stored on 3.5-Mb digital cassettes for map matching and display purposes. Although sales were modest, the highly publicized Etak Navigator drew widespread attention to the concept of an electronic map display with icons showing current location and destination.

The Travepilot, which is essentially a second generation of the Navigator, was jointly designed by Etak, Inc. and Bosch GmbH.<sup>5</sup> It was introduced in Germany in 1989 and in the United States two years later. One of the most conspicuous enhancements was the use of CD-ROM storage for digitized maps. The 640-Mb capacity permits the entire map of some countries to be stored on a single CD-ROM.

Like its predecessor, the Travepilot displays a road map of the area around the vehicle, as illustrated by Fig. 29.7. The vehicle location and heading is indicated by the arrowhead icon below the center of the screen. The vertical bar at the right edge of the map indicates the dis-

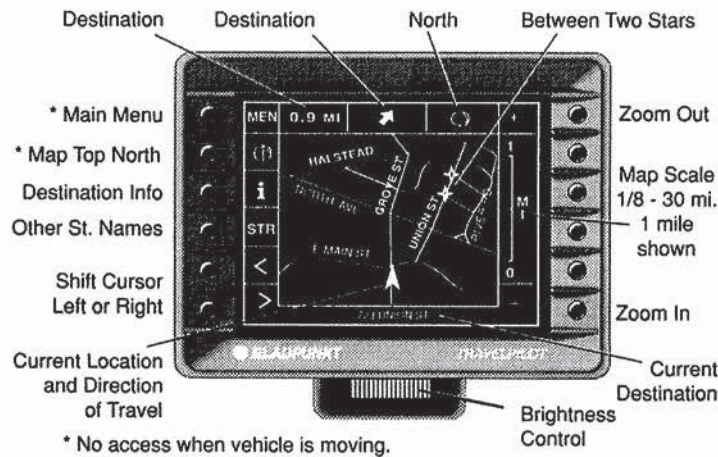

FIGURE 29.7 Bosch Travepilot display and controls. (Bosch literature)

play scale which can be zoomed in to  $\frac{1}{2}$  mile for complete street detail or out to 30 miles to show only major highways. The map is normally oriented such that the direction in which the vehicle is heading points straight up on the display, thus allowing the driver to easily relate the map display to the view outside.

When parked, a menu accessible through the MEN button permits use of soft-labeled buttons in a scrolling scheme to enter destinations by street address, intersection, etc. Travelpilot uses a process called *geocoding* to locate an input destination and display it as a flashing star on the map. As illustrated in Fig. 29.7, a destination geocoded by street address is bracketed by two flashing stars when the map is zoomed in. In this case, the stars mark the block whose address range includes the street number of the destination. A line of information across the top of the map display indicates the crow-flight distance and points the direction from the vehicle's current location to the destination. Up to 100 input destinations may be stored for future use.

A submenu provides several methods for the driver to reset the vehicle's position on the map if the Travelpilot gets off track. The frequency with which the system requires reinitializing depends upon dead-reckoning anomalies and the completeness and accuracy of the map data for the area being driven. For example, map matching typically fails once in a thousand miles when operating in an environment like greater Los Angeles or North Texas. As for location accuracy the rest of the time (i.e., with map-matching operative), Travelpilot is claimed to have infinitesimal error relative to the map. The map-matching performance is compared to that of a servo-amplifier in which map-matching failure corresponds to losing servo-lock to the map.

The Travelpilot hardware includes a V50 processor,  $\frac{1}{2}$ -Mb DRAM, 64-Kb EPROM, and 8 Kb of nonvolatile RAM for storing vehicle location while the ignition is off, calibration factors, up to 100 saved destinations, etc. The Travelpilot may interact with other devices through an RS-232 serial port and an expansion card slot. For example, Travelpilots in 400 Los Angeles fire trucks and ambulances are connected by digital packet radio to the city's emergency control center. The emergency operators can monitor each vehicle's location and status, and can send destinations directly to a vehicle's Travelpilot for emergency dispatch.

### 29.3.2 Toyota Electro-Multivision

The Toyota Electro-Multivision has undergone numerous refinements since it was introduced in 1987 as the first sophisticated navigation system available as a factory option on automobiles sold in Japan. Except for a few features, it is representative of the more comprehensive models of navigation systems now available in Japan from almost all of the major automobile and electronics manufacturers.

Many Electro-Multivision features may be summarized with reference to those of the Travelpilot previously described in more detail. Both use dead reckoning and digitized maps stored on CD-ROM for display on a CRT screen with an icon representing present position, and are generally similar in their basic navigation features. However, a raster-scan color CRT rather than a vector-drawn monochromatic CRT is used in the Electro-Multivision. Also unlike Travelpilot, the Electro-Multivision map database includes yellow pages information such as the locations of facilities likely to be of interest to motorists.

The Electro-Multivision also serves as a reference atlas. In the original version, for example, a display shows a color map of all Japan with 16 superimposed rectangles. Touching a particular rectangle causes the map area it encompasses to zoom and fill the entire screen, again with grid lines superimposed to form 16 rectangles. Thus, a few touches of the screen takes the driver from an overview of the entire country down to major roads and landmarks in some quarter of Tokyo.

However, in spite of Electro-Multivision's sophisticated map-handling capabilities, map matching was not used in the first version because the digital maps then available for Japan did not contain sufficient detail at the city street level. In addition to detailed digital maps and map matching, subsequent versions of Electro-Multivision include a GPS receiver and a color

LCD rather than CRT display.<sup>6</sup> In 1991, a routing feature was added to calculate a suggested route to specified destinations and highlight the trace on the LCD map display. The most recent version<sup>7</sup> adds synthesized voice route guidance instructions.

As is the case for most other state-of-the-art navigation systems offered as factory-installed equipment in Japan, the Electro-Multivision navigation features are integrated with a full suite of entertainment features (e.g., AM-FM radio, tape cassette, audio CD player, color TV, etc.). In addition, the Electro-Multivision includes a CCD camera for rear vision on the LCD screen.

### 29.3.3 Oldsmobile Navigation/Information System

In January 1994, Oldsmobile announced its Navigation/Information System, the first navigation and route guidance system to be offered as a dealer-installed option from an automobile manufacturer in the United States. Initially sold only in California, the system was expected to be offered nationwide as digital map databases for other areas become available during 1994-1995.

The Oldsmobile system integrates a GPS receiver with dead reckoning and map matching. The dead-reckoning process uses gyroscopic and odometer inputs. A PCMCIA card is used for storing a map database which includes the locations of points of interest such as emergency services, restaurants, major retail stores, schools, office buildings, tourist attractions, etc. The major hardware modules of the system are shown in Fig. 29.8.

Destinations may be entered as specific street addresses or road intersections, or by selecting categories and scrolling through the points of interest included in the database. Routing criteria (e.g., avoiding expressways) may also be specified. The navigation computer then calculates the route and highlights it on a 4-in active matrix color LCD. Once underway, the distance to and direction of each turn is displayed on the screen and a voice prompt advises the driver as each turn is approached. A representative route guidance screen is shown in Fig. 29.9.

The Oldsmobile Navigation/Information system is supplied by Zexel USA Corp. and is an adaptation of Zexel's NAVMATE system which has been under development for several years specifically for the U.S. market.

### 29.3.4 TravTek Driver Information System

Whereas these examples of automobile navigation systems are already available in certain markets, TravTek was a functional prototype of a navigation-based in-vehicle traveler information system developed specifically for the TravTek IVHS operational field trial conducted for a one-year period ending in 1993 in Orlando, Florida. The field trial was a joint public sector-private sector project with the primary objective of obtaining field data on the acceptance and use by drivers of navigation and other information provided by comprehensive in-vehicle systems linked with traffic operations and other data centers.

The TravTek project used 100 General Motors automobiles equipped with the system shown schematically in Fig. 29.10 to provide navigation, route selection and guidance, real-time traffic information, local yellow pages and tourist information, and cellular phone service.<sup>8</sup> Most of the automobiles were made available to Orlando visitors through Avis Rent A Car for short-term trials and the rest were assigned to local drivers for extended periods. The American Automobile Association selected the test subjects and operated a TravTek Information and Services Center which could be accessed via cellular telephone.

TravTek navigation is based on a combination of dead reckoning and map matching, with a GPS receiver playing a "watchdog" role. TravTek's navigation function superimposes vehicle location on a map display screen, highlights suggested routes on the color CRT map display, and issues route guidance instructions via synthesized voice. Alternatively, turn-by-turn route guidance instructions may be displayed in the form of simplified graphics.

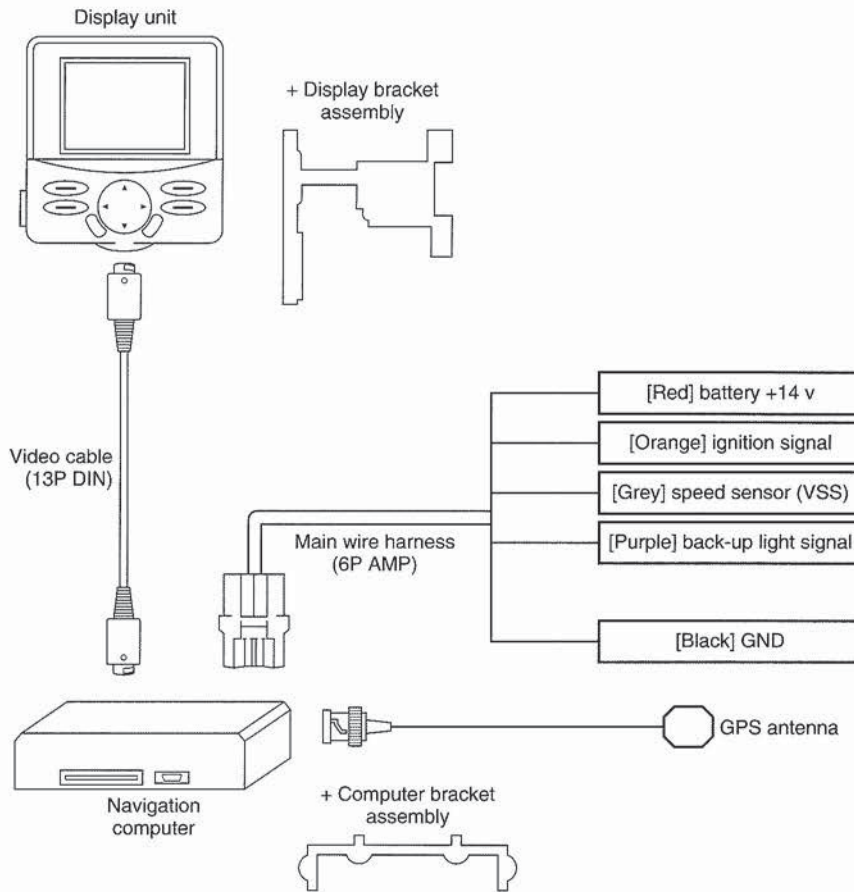

**FIGURE 29.8** Oldsmobile Navigation/Information System hardware. (*Oldsmobile*)



**FIGURE 29.9** Oldsmobile Navigation/Information System route guidance screen. (*Oldsmobile*)



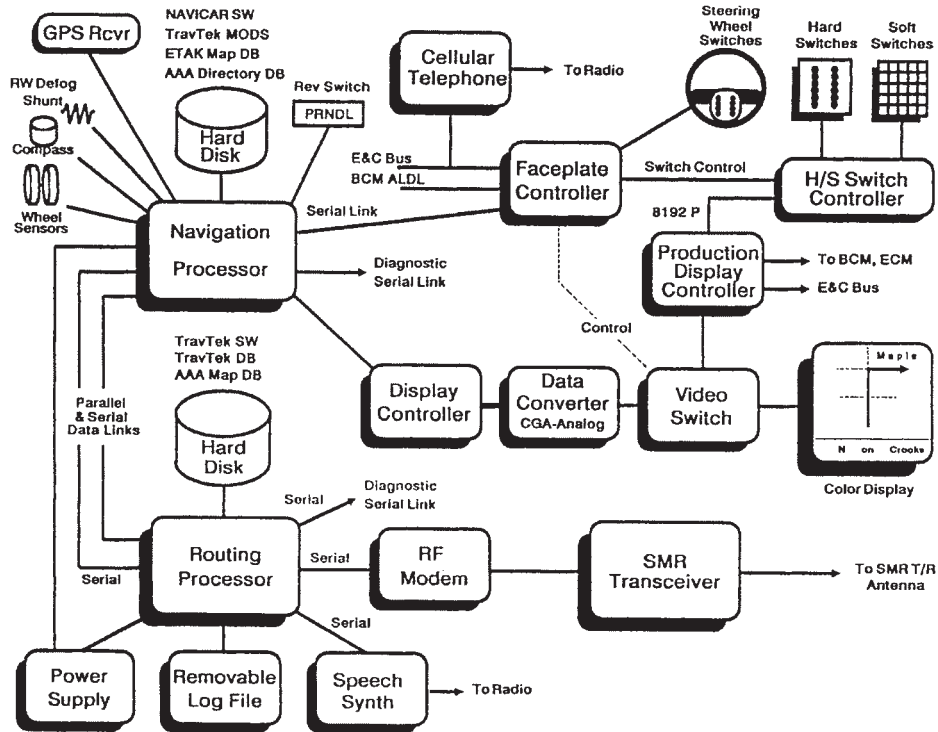

FIGURE 29.10 Architecture of TravTek vehicle system.<sup>8</sup>

Although functionally realistic, the TravTek in-vehicle system design used some features that would not typically appear in a production system. For example, rather than consolidated databases stored on a single CD-ROM or other data storage device, TravTek used separate map databases stored on separate hard disk drives for navigation processing and route guidance processing.<sup>9</sup>

However, compared to these examples of commercially available navigation and route guidance systems, TravTek’s most distinct difference was the capability to superimpose information on current traffic conditions on the map display and to take traffic congestion levels into account in calculating recommended routes. The traffic information was received over a radio link from a special Traffic Management Center (TMC) operated by the City of Orlando in conjunction with the Federal Highway Administration and the Florida Department of Transportation. The TMC consolidated traffic data from various sources including “probe” data consisting of road segment travel times received via mobile radio from the TravTek vehicles themselves.

**29.4 OTHER IVHS SYSTEMS AND SERVICES**

A central aspect of IVHS (Intelligent Vehicle-Highway Systems) is the operation of advanced traffic management systems (e.g., the TravTek TMC outlined here) in conjunction with automobile navigation and route guidance systems. This requires the use of mobile data commu-

nication links between the infrastructure and in-vehicle systems. Although the United States, Europe, Japan, and other developed countries are now systematically pursuing IVHS development, selection of mobile data communication approaches remains under consideration as this handbook is prepared. However, it is generally expected that one or more of the approaches characterized in Table 29.1 will be selected for most geographical areas.

**TABLE 29.1** Characteristics of Alternative Mobile Data Communication Approaches

Approach	Characteristics
FM sideband	One-way Low data rates Extended area coverage
Proximity beacon	One-way or two-way High data rates Spot area coverage
Inductive loop	One-way or two-way Low data rates Spot area coverage
Land mobile	Two-way Local area coverage
Specialized mobile radio	Two-way Extended area coverage
Cellular radio	Two-way Local/extended area coverage
Mobile satellite	One-way or two-way Wide area coverage
Meteor burst	Two-way Wide area coverage Involves time delays

The vast scope of IVHS is made easier to comprehend by subdivision into several interrelated and overlapping categories that have been used to structure the IVHS program in the United States: Advanced Traffic Management Systems (ATMS), Advanced Traveler Information Systems (ATIS), Advanced Vehicle Control Systems (AVCS), Commercial Vehicle Operations (CVO), Advanced Public Transportation Systems (APTS), and Advanced Rural Transportation Systems (ARTS).

#### 29.4.1 Advanced Traffic Management Systems (ATMS)

ATMS includes freeway surveillance and incident detection, changeable message signs, electronic toll collection, and coordination of traffic signal timing over wide areas in response to real-time traffic conditions. Major elements of ATMS have been around for decades. The first computerized traffic signal control systems were developed in the 1960s, and approximately 200 computerized traffic signal control systems were in use in North America by the end of the 1980s. About 25 major freeway surveillance and control systems were in use, including many dating from the 1960s and 1970s. Electronic toll collection did not start experiencing significant implementation until the 1990s.

An additional ATMS function is to supply real-time traffic information (e.g., link travel times) over mobile data communication links to ATIS. The final selection of one or more communication links is unsettled because, among other things, their requirements (e.g., data rates) are highly dependent upon system architecture and the division of functions between infrastructure and in-vehicle equipment.

#### 29.4.2 Advanced Traveler Information Systems (ATIS)

ATIS systems acquire, analyze, communicate, and present information to assist surface transportation travelers in moving from one location to another. Initially called ADIS (Advanced Driver Information Systems) by Mobility 2000 and essentially limited to navigation, route guidance, and traffic information presented by in-vehicle systems, ATIS concepts now also encompass the provision of transit schedules and connections to home, office, kiosk and hand-held PPATIS (Portable ATIS) units as well as in-vehicle units. Vision enhancement devices for drivers also fall under the ATIS category.

Although PPATIS concepts are proliferating, most early ATIS market activity is expected to be what was originally called ADIS and will be centered on in-vehicle navigation and route guidance systems. A 1991 Delphi study by the University of Michigan forecasts some form of navigation incorporating GPS will be used in 5 percent of all vehicles sold annually by 2000 and in 50 percent by 2012. IVHS strategic planning assumes that manufacturers will sell 2.5 million vehicles annually with factory-installed ATIS by the year 2000.

The potential of the ATIS market is also illustrated by the fact that approximately 500,000 sophisticated automobile navigation systems had already been sold (mostly as factory options) in Japan by the end of 1993, even though they must operate autonomously because mobile communication links to ATMS traffic operations centers for enabling dynamic route adjustment according to traffic conditions have thus far been limited to developmental tests.

#### 29.4.3 Advanced Vehicle Control Systems (AVCS)

Whereas ATIS assists drivers by providing information to facilitate efficient and safe operation, AVCS provides direct assistance with vehicle control. An existing example is ABS (antilock braking system). Other early forms of AVCS include obstacle detection and warning systems and intelligent cruise control. Intelligent cruise control automatically adjusts speed according to distance and speed of the vehicle being followed, and enables platooning concepts wherein closely spaced vehicles travel in groups to increase lane capacity and safety. AVCS may ultimately lead to fully automated chauffeuring.

Most of the more advanced forms of AVCS such as automatic lane keeping (lateral steering control) are still in the laboratory stage. Although driver warning, perception enhancement, and assistance/control systems are under active research and testing in the United States, Europe, and Japan, the most comprehensive demonstrations to date have been accomplished under Europe's PROMETHEUS program.

#### 29.4.4 Commercial Vehicle Operations (CVO)

In addition to benefiting from ATMS, ATIS, and AVCS functions, commercial vehicle operations may be made more productive through additional IVHS functions. These include automatic vehicle location monitoring, computerized dispatch and fleet management systems for dynamic scheduling and routing, weigh-in-motion (WIM), automatic vehicle classification (AVC), automatic vehicle identification (AVI), on-board data acquisition computers, etc.

The earliest CVO applications were for managing critical urban fleets (e.g., police vehicles starting in the 1970s). However, extensive application of communication and location reporting schemes to long-distance trucking fleets got underway in the 1980s. Much of the present CVO activities (e.g., AVI, AVC, WIM) focus on this application with the objective of eliminating stops and regulatory paperwork now required when traveling from state to state.

#### 29.4.5 Advanced Public Transportation Systems (APTS)

APTS encompasses some forms of CVO (e.g., automatic vehicle location reporting), as well as additional functions such as schedule monitoring for transit buses. APTS also includes

HOV (high-occupancy vehicle) lanes and instant car-pooling services. Although AVL implementation for transit buses was limited until the present generation of GPS-based systems started becoming available, extensive research and trials were conducted during the 1970s under auspices of the Urban Mass Transit Administration (recently renamed Federal Transit Administration). The use of AVL and communications technologies to monitor, control, and manage public transit continues to be a central thrust of APTS.

New APTS thrusts include making timely and accurate information on traffic conditions and on transit and ride-sharing alternatives readily available to travelers (especially commuters who normally drive alone) for pretrip planning. Another is to improve the customer interface through the use of integrated electronic fare systems such as smart cards valid for all transportation modes, and through the provision of real-time transit service information at homes, offices, and public places as well as at stops, aboard vehicles, etc. APTS also includes systems for controlling HOV access and enforcing proper usage.

#### 29.4.6 Advanced Rural Transportation Systems (ARTS)

ARTS has the greatest overlap with other segments of the IVHS industry in that few, if any, additional functions or technologies are required. Instead, safety dominates rural IVHS planning with emphasis on in-vehicle safety advisory and warning systems, prevention of single-vehicle off-road accidents, prevention of passing accidents, warnings of animals on or near the roadway, vision enhancement, and Mayday calls from stranded vehicles. Although virtually all of these may evolve under other IVHS segments, ARTS communications considerations differ significantly from those of urban areas because lower population densities and fewer roads combined with greater distances among facilities require greater dependence upon wide-area communications.

## REFERENCES

1. R. L. French, "Historical overview of automobile navigation technology," *Proceedings, 36th IEEE Vehicular Technology Conference*, Dallas, Texas, May 20-22, 1986, pp. 350-358.
2. D. A. Rosen, Mammano, F. J., and Favout, R., "An electronic route guidance system for highway vehicles," *IEEE Transactions on Vehicular Technology*, vol., VT-19, 1970, pp. 143-152.
3. R. L. French, "Evolution of automobile navigation in Japan," *Proceedings, 49th Annual Meeting of the Institute of Navigation*, Cambridge, Massachusetts, June 21-23, 1993, pp. 69-74.
4. R. L. French, "Map matching origins, approaches, and applications," *Proceedings, Second International Symposium on Land Vehicle Navigation*, Munster, Germany, July 4-7, 1989, pp. 93-116.
5. J. L. Buxton, Honey, S. K., Suchowskyj, W. E., and Tempelhof, A., "The Travelpilot: a second-generation automotive navigation system," *IEEE Transactions on Vehicular Technology*, vol. 40, no. 1, 1991, pp. 41-44.
6. K. Ishikawa, Ogawa, M., Azuma, S., and Ito, T., "Map navigation software of the Electro-Multivision of the '91 Toyota Soarer," *Proceedings, VNIS'91—Vehicular Navigation & Information Systems Conference*, vol. 1, Dearborn, Michigan, Oct. 20-23, 1991, pp. 463-473. [Also known as SAE Paper No. 912790.]
7. T. Ito, Azuma, S., and Sumiya, K., "Development of the new navigation system—Voice Route Guidance," Society of Automotive Engineers Paper No. 930554, 1993.
8. M. K. Krage, "The TravTek Driver Information System," *Proceedings, VNIS'91—Vehicular Navigation & Information Systems Conference*, vol. 2, Dearborn, Michigan, Oct. 20-23, 1991, pp. 739-748. [Also known as SAE Paper No. 912820.]
9. J. H. Rillings and Krage, M. K., "TravTek: an operational advanced driver information systems," *Proceedings of the 1992 International Congress on Transportation Electronics*, SAE P-260, 1992, pp. 461-472.



**ABOUT THE AUTHOR**

Robert L. French is a pioneer in automobile navigation and IVHS. He has been involved with navigation since 1969 and invented map-matching technology, now used in virtually all automobile navigation systems. He was commissioned in 1993 by IVHS America to serve as principal investigator leading an international team of experts in performing a comparative analysis of IVHS progress in the United States, Europe, and Japan. Early in 1994, he was selected by the U.S. Department of Transportation as one of 12 experts to serve on the technical review team for the three-year National IVHS System Architecture Development Program.



---

# CHAPTER 30

---

## ELECTRIC AND HYBRID VEHICLES

---

**George G. Karady, Tracy Blake**

*Arizona State University*

**Raymond S. Hobbs**

*Arizona Public Service Company*

**Donald B. Karner**

*Electric Transportation Application*

---

### 30.1 INTRODUCTION

---

Electric vehicle (EV) technology is under rapid development. Several different types of experimental vehicles are in operation in the United States and elsewhere. Each vehicle uses different technologies and systems. Most are converted from standard internal combustion engine vehicles (ICEV). Because EV technology is still in its infancy, trends and future development cannot be assessed. Only the present status and a possible outlook can be identified.

This chapter will present a description of the current technology available in EVs today and identify the areas where technological breakthroughs will be required to produce EVs that can successfully compete with the ICEV.

#### 30.1.1 History of the EV

Electric vehicle development preceded the development of cars with internal combustion engines (ICE). Thomas Davenport built the first battery-powered car in the United States in 1835.<sup>1</sup> Easy control and starting of electric motors and a lack of gas stations promoted the use of battery-powered cars. However, fast development of the internal combustion engine and discovery of the electric starter motor halted development of EV technology. The use of electric vehicles was restricted to a small number of local delivery trucks and cars. An example is the U.S. Postal Service which used battery-powered trucks for mail delivery in New York City for several decades.

Increasing air pollution in the late 1960s prompted the development of experimental electric vehicles. But the automobile industry significantly reduced vehicular emissions, which again halted EV development. In the early 1970s, a gasoline shortage following the Arab oil embargo renewed interest in electric vehicles, but generated only a few inadequate vehicles.

30.1

The major problem with these EVs was their relatively small operating radius (traditional fuels have about a 20 times greater energy density than batteries).

Increased industry interest occurred recently when the California Air Resource Board (CARB) mandated that in California two percent of all new vehicles lighter than 1700 kg must produce zero tailpipe emissions by 1998.<sup>2</sup> The proportion of zero-emission vehicles must increase to five percent by 2001 and 10 percent by 2003. Other states in the Northeast are considering adopting similar regulations to improve air quality. Presently, electric vehicles are the only commercially feasible zero-emission vehicles.<sup>3</sup> This mandatory reduction of air pollution has promoted vigorous research programs in both the United States and abroad.<sup>4</sup> All major automobile manufacturers started programs in the late 1980s to manufacture viable electric vehicles by 1998.

### 30.1.2 Electric Vehicle Performance

The main focus of EV developmental programs is to produce cars that are competitive with present-day ICEVs. In order to demonstrate the present state-of-the-art technology, Table 30.1 shows the performance of the Solectria E-10 pickup trucks. The United States-made Solectria E-10 (Solectria Co., Arlington, Mass.) is commercially available and is typical of EVs on the market today, which allows for a direct comparison to ICE-powered pickup trucks.

**TABLE 30.1** Performance Rating of the Solectria E-10 Pickup Truck

Performance parameter	Rating
System power	42 kW
Horsepower	56 HP
Torque	73 ft-lb
Gradeability	18%
Acceleration, 0–50 km/h	9 s
Top speed	100 km/h
Efficiency at 75 km/h	240 Wh/m
Curb weight	1680 kg
Range at 80 km/h	130 km
Payload (2 passengers +)	90 kg

The Solectria E-10 is powered by an ac induction motor with a direct-drive automatic transmission and a regenerative braking system. It has power-assisted brakes, power steering, an electric heater, and an on-board 2-kW 110-V battery charger. Typical ICEV pickup trucks have a range of 550 to 750 km and a top speed of 150+ km/h. The Solectria E-10 is a well-designed EV but with a top speed of 100 km/h and a range of 130 km, it does not compare very well to the ICEV pickup trucks.

A review of different electric vehicles has led to the assessment that present day EV performance is less than that of ICEVs. To demonstrate the status of EVs, major performance parameters are compared.

**Range.** The major limitation of EV performance is the small operating range. An average ICEV travels 750 to 1100 km on a tank full of gas and refueling requires 5 to 10 minutes. The range of present-day electric vehicles is less than 150 km and the “refueling” (battery-charging) time is measured in hours. Statistical surveys indicate that the average car travels less than 50 km a day, which is well within the operating range of present-day EVs. The short range is due to the low energy density in the batteries. The specific energy density in a lead-acid battery varies between 30 and 35 Wh/kg, which is significantly less than the 12,000 Wh/kg energy density of standard automotive fuel. The practical operating range depends on the speed, driving pattern, weather (temperature), and battery condition (age).



**Weight.** Because of the low energy density, electric cars are heavier than similar gas-powered vehicles. The specific weight of a small electric car is around 20 W/kg.

**Speed.** The operating speed and acceleration of the EV is somewhat lower than today's ICEVs. This is particularly valid for highway driving. Although electric racing cars can run over 200 km/h for a short length of time, manufacturers normally limit the maximum speed of the electric vehicle to around 120 km/h. In general, the EV is well suited for city driving.

**Acceleration.** Starting acceleration of today's EVs is comparable to that of ICEVs. However, acceleration of the EV at high speeds (from 110 km/h) and hill-climbing ability is significantly less than the present-day ICEVs.<sup>4</sup> A lack of high-end acceleration may produce safety problems during highway driving.

**Cost.** Because of the low energy density in the batteries, lightweight construction and high efficiency will be required by the EV. To achieve high efficiency, the EV must have a low rolling resistance, low coefficient of drag (aerodynamic), and have a high efficiency air conditioning/heating unit. Simultaneously, the vehicle must be crashworthy. Most EVs use a large number of expensive power electronic components and microprocessors. Consequently, the initial cost of an EV is significantly higher than that of a gas-powered vehicle.

Expected operational costs of an EV should be less than a comparable ICEV. General Motors Corporation's Storm ICEV, with manual transmission, drives approximately 50 km on \$1 worth of gasoline. The comparable General Motors Impact EV drives approximately 120 km on \$1 worth of electricity, assuming the cost of electricity to be \$0.12/kWh.<sup>2</sup>

**Maintenance and Lifetime.** Wear of the EV's electric components is significantly less than the wear on the ICEV that is operating at high temperatures, is liquid cooled, and has many more moving parts. Therefore, maintenance requirements for the EV are significantly less and the useful lifetime of an electric vehicle is significantly longer than the ICEV. The only component that requires high maintenance and has a short life span is the battery. Currently, the lifetime of lead-acid batteries is only a few years. This led to the proposal that the batteries should be considered as a part of the operating expenses. Roadside service may charge the battery pack instead of quick charging.

In order to assess the status and feasibility of commercial use of electrical vehicles, Table 30.2 gives typical performance and technical data for electric vehicles currently under development.

### 30.1.3 Motivation to Use Electric Vehicles

Zero emissions of the EV is the main motivation for considering its use. Air pollution produced by ICEVs in large cities have reached critical levels. These levels can be decreased by reduction of emissions from internal combustion engines. Switching to electric-powered vehicles will reduce pollution levels but will increase the consumption of electricity, thereby increasing the air pollution produced by electric power generation. Considering only vehicle and power plant pollution, a switch to electric vehicles would practically eliminate carbon monoxide, ozone, and volatile organic compounds from the air. Carbon dioxide levels would be halved and nitrogen oxide levels would be cut by 20 to 25 percent, but sulfur dioxide levels would increase. Sulfur dioxide is a byproduct of coal-fired power plants. It is hoped that by the late 1990s, power plants will install equipment to reduce nitrogen oxide and sulfur dioxide emissions, which will reduce acid rain.

A second motivation for EV use would be in a reduction of dependency on imported oil. Only four percent of the electric energy generated in the United States uses petroleum-based fuels, while fuels for ICEVs are exclusively based on petroleum. A third advantage is that most electric cars will be charged at night during off-peak hours. This increases utilization of

TABLE 30.2 Selected Technical Data for Electric Vehicles.<sup>2</sup>

Vehicle	Developers	Type	Status	Battery	Range, km	Top speed, km/h	Comments
BMW E1/E2	BMW AG (Germany); Unique Mobility (U.S.)	4-passenger car	Concept; no production plans announced	Sodium/sulfur	240	120 (E1)	E1 uses a 32-kW permanent magnet dc motor
Ecostar	Ford Motor Co. (U.S.)	Minivan based on Ford's European Escort	80-100 were produced in 1993 and leased for 30 months	Sodium/sulfur	160	120 (governed)	Uses a three-phase, 56-kW ac induction motor integrated into front transaxle
Fiat Panda Elettra	Fiat SpA (Italy)	Passenger car	Production run of 500 planned	Lead/acid Nickel/cadmium	80 104 (city driving)	113	Uses a 9.2-kW series dc motor
GM Impact	GM, Aero-Vironment Inc. (U.S.)	2-seater sub-compact sports car	Commercial production in mid-1990s	Lead/acid	190 (at 90 km/h)	120 (governed)	Uses two 43-kW ac induction motors
G-Van	EPRI, General Motors Corp. (U.S.); Conceptor Industries Inc. (Canada)	Passenger/cargo van based on GM Vandura glider	About 100 in service in commercial fleets—mostly utilities	Lead/acid	96 (city driving)	83	Uses a 43-kW dc motor
LA 301	LADWP, SCE, Clean Air Transport (U.S.)	2-passenger, series hybrid car	Commercial production projected for 1993	Lead/acid Sodium/sulfur	96 154	97	Hybrid version with sodium/sulfur battery and auxiliary ICE has range of 240 km
Mercedes-Benz 190EV	Mercedes-Benz AG (Germany)	5-passenger, 4-door car	Research car	Sodium/nickel chloride	150	120	Uses two external-rotor dc motors
Nissan FEV	Nissan Motor Co. (Japan)	Passenger car	Concept; no production plans announced	Nickel/cadmium	160 at 72 km/h	120	Can accept a 40% charge in 6 min; has solar cells in roof to augment battery
Renault Zoom	Renault (France); Matra SA (France)	2-passenger car	Concept; production version under development	Nickel/cadmium	150	120	Wheelbase shortens from 1845-1245 mm for parking
Tepco Iza	Tokyo Electric Power Co. (Japan)	4-passenger car	Concept car; only one built	Nickel/cadmium	550 at 40 km/h	176	Has 25-kW brushless dc motor inside each wheel
TEVan	EPRI, Chrysler Corp., SCE (U.S.)	Passenger/cargo minivan based on Chrysler minivan glider	About 50 were produced in 1993	Nickel/iron	180	105	Uses a 46-kW dc motor
Volkswagen CityStromer	Volkswagen AG (Germany)	Passenger car	70 vehicles using lead/acid battery built and sold	Lead/acid Sodium/sulfur	140 120	104	Based on Jetta production vehicle

EPRI = Electric Power Research Institute; ICE = internal combustion engine; LADWP = Los Angeles Department of Water and Power; SCE = Southern California Edison Co.

existing power plants and reduces energy costs. Utilities intend to offer lower rates to charge vehicles during off-peak hours and penalties to those charging during peak hours. The United States government is considering tax credits to EV users, which will partially offset the higher purchase costs.

### 30.2 SYSTEM DESCRIPTION

An electric drive system has been used in almost every transportation application that ICEV has used, including light cars and vans to large city buses. Most EVs use the body and mechanical parts of commercially available ICEVs. Two examples are Ford Motor Company's Ecostar van and the Mercedes-Benz 190E sedan. General Motors' Impact sports coupe is one of the few EVs that has been specially designed as an EV. Figure 30.1 shows a block diagram and the major components of a typical EV.

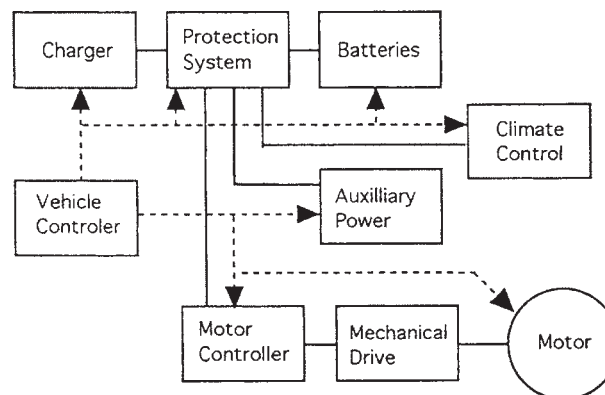

**FIGURE 30.1** System-block diagram of a typical electric vehicle (EV).

The major components are:

1. *Charger.* It rectifies the ac network voltage for charging of the batteries.
2. *Protection system.* It consists of circuit breakers, relays, and fuses that are connected between the batteries and the rest of the electrical system and interrupt the supply in case of a fault.
3. *Motor.* EVs use both ac and dc motors.
4. *Motor controller.* This system controls the drive motor speed and torque. Both ac and dc drives are used.
5. *Mechanical drive system.* It consists of the transmission, differential, power steering, and so forth.
6. *Vehicle controller.* Most advanced EVs use a microprocessor-based controller that monitors the status of each of the major components and initiates control or protection actions as needed.
7. *Batteries.* The battery pack provides energy for the vehicle propulsion.
8. *Climate control system.* This system includes efficient air conditioning and heating systems.
9. *Auxiliary power.* It supplies the headlights, instrumentation, door opener, auxiliary motors (e.g., for the sunroof), power steering, etc.

The location of the major components depends upon vehicle type and construction. Several different arrangements are used by the EVs currently available.

EV technology is being developed at a fast pace. Several new types of vehicles are currently being tested. In some vehicles, the major components identified in Fig. 30.1 are combined. Some of the components, such as the protection system and auxiliary supply system, are similar to those used on standard ICEVs.

### 30.3 CHARGER AND PROTECTION SYSTEM

---

EVs can be charged overnight during off-peak hours or at a roadside station. The overnight slow charging takes 8 to 10 hours using a 240-V, 30-A connection. Quick charging requires several hundred amperes and takes 15 to 30 minutes. Today's EVs are equipped with slow chargers.

#### 30.3.1 Chargers

The charger on an electric vehicle consists of a rectifier that converts the 240-V ac to the proper dc level required for charging. In most cases, this rectifier is mounted on the vehicle. However, it was proposed that the rectifier be installed in the charging station, where an advanced computer control would determine the charging voltage and the battery charge level. Subsequently, the computer will adjust the charging voltage to assure efficient and fast charging of the batteries.

The most simple technical solution is to use phase controlled rectifiers which control the charging rate by the delay of the device turn on. Figure 30.2 shows the connection diagram and typical voltage and current waveforms of a single-phase thyristor-controlled battery charger. Variance of the delay angle changes the average dc voltage and the charging current.

In some vehicles, the battery-charging circuit performs a dual role and is used to control motor current while the vehicle is being driven. The Ford Econstar minivan uses this concept of a combined charger and drive controller. It can be built with high-power transistors, MOS-FETs, or insulated gate bipolar transistors (IGBTs). The circuit shown in Fig. 30.2 can be used as an inverter to drive ac motors or as a chopper to drive dc motors. A switching circuit is required to change from the charging mode to the drive (discharging) mode.

The connection between the vehicle and the charging station is currently under development. Two different systems have been proposed.<sup>5</sup> The first would use the transformer principle in which the ac system is connected to the vehicle charger through an inductive coupling, a transformer with two isolated coils. The coils are coupled with an iron core. The major advantage of this system is that the vehicle is not connected galvanically to the electrical network. This reduces the danger of touching energized parts or electrical accidents caused by ground faults. The separation of the vehicle from the network permits supplying of the inductive coupling from a higher voltage (480-V) three-phase system. This allows larger loads and suggests the use of the inductive coupling for quick-charging stations.

The second system connects the charging station to the vehicle charger through a metal plug similar to that used in outdoor appliances. Several different plug configurations are under development. The major requirements are that the plug has to be waterproof and touchproof, it has to withstand abuse and resist vandalism, it has to be energized only after it is connected to the vehicle charger, and damage of the plug should activate a protection system which would prevent energization.

#### 30.3.2 Protection System

The battery and the electronic circuits must be protected against faults and short circuits. A short circuit in the car electric system discharges the battery. During a fault, the energy stored in the battery is converted to heat which can melt wires in the vehicle's electric system. Also,



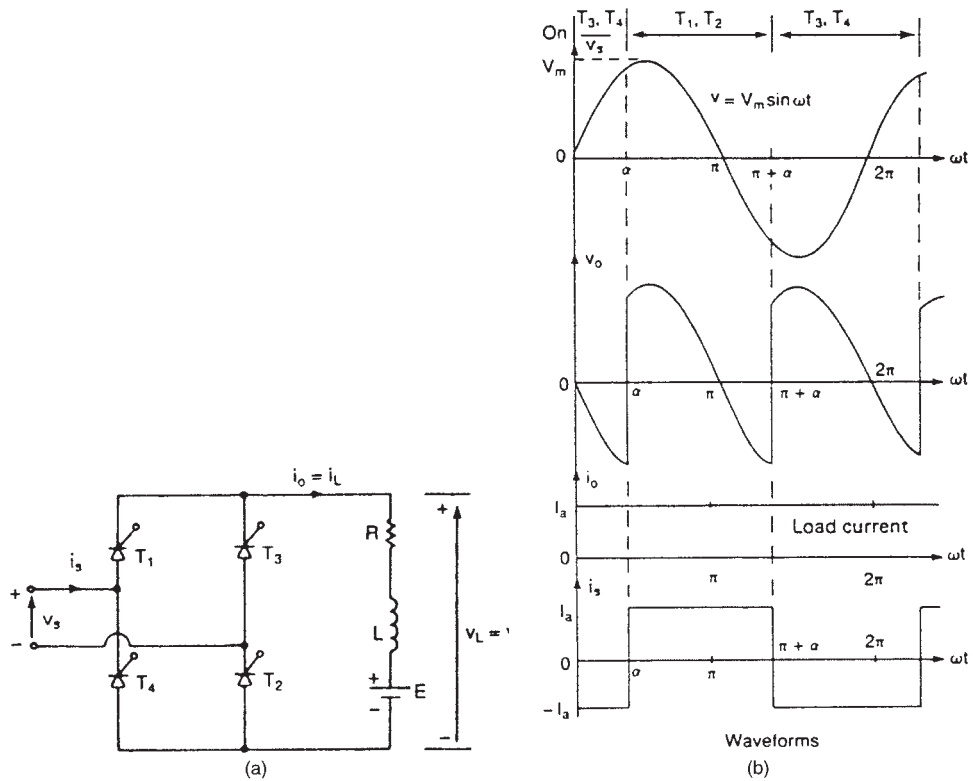

FIGURE 30.2 Thyristor-controlled battery charger: (a) connection diagram; (b) current and voltage waveforms.

a short circuit in a dc system may produce a large electric arc. Both the sudden heat generation and arcing endanger the life of the driver and passengers. Another problem is that the battery voltage in most EVs is between 100 and 200 V. In adverse conditions such as wet weather, this voltage level could cause electrocution.

Recognizing these problems, the manufacturers build electric vehicles with an ungrounded floating electrical system. The metal parts of the car's body are insulated from the electrical system and the tires insulate the car's body from the ground. In such a system, the first insulation fault between the electric system and the body will not produce battery discharge current. However, the second fault will short circuit the battery and endanger the operator.

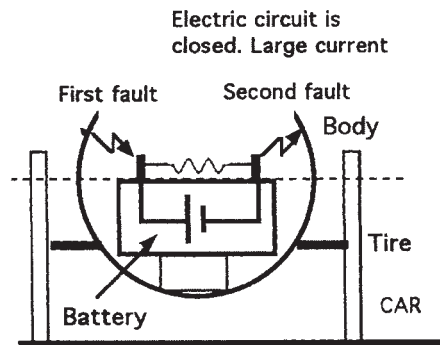

FIGURE 30.3 Effect of insulation faults in an EV.

A possible fault scenario is a leakage path created by the conducting deposits produced by acid discharge from the battery. This conducting path can connect one terminal of the battery to the body, which is the first fault. Cable friction against body parts could cut the insulation, which may connect the conductor to the body of the vehicle and produces the second fault. This second fault will generate a short circuit. Figure 30.3 shows a schematic of the electric circuit and the current paths produced by the faults.

Detection of the first insulation fault is very important. This may be achieved by a sensitive ground-fault protection circuit, which is similar to that used in bathrooms and kitchens in United States homes.

The second fault produces a short circuit which must be interrupted within milliseconds to prevent battery discharge. Fast-acting magnetic or electronic circuit breakers and/or fuses can provide adequate protection.

The operation of EVs in adverse conditions—snow, mud, and long inclines—may produce overloading of the electrical drive circuit and overheat the battery, motor, or cables. Overheating also reduces the life span of the insulation. The electronic drives have built-in overload protection but backup protection in the form of circuit breakers or fuses will prevent costly damage from fault conditions.

The electrical circuit backup protection used in most EVs consists of devices which are similar to those used in standard ICEVs. In addition to the breakers and fuses, microprocessor-based vehicle controllers are equipped with protection circuits, which provide primary protection by turning off systems which are affected by the fault.

The EV requires interlocks to assure safe operation.<sup>4</sup> The interlocks can be software-programmable in the vehicle control system or can be of the mechanical or relay type. Some of the frequently used interlocks are:

- *Charger interlock.* Prevents the starting/driving of the vehicle when the charger is plugged in; disables the electric drive circuit while the charger is plugged in or operating.
- *Heater/air conditioner interlock.* Disables the climate control system or switches it to the charger while the vehicle is being charged.

## 30.4 MOTOR DRIVE SYSTEM

---

The first electric vehicles used standard ac or dc motors but the required high efficiency and torque led to the development of special motors.

### 30.4.1 Motors

Important factors in choosing motors for EV applications include high efficiency, favorable torque characteristics, maintenance-free operation, and insensitivity to overload and contamination. Cost is also a major factor in motor selection.

**AC Motors.** EVs which use an ac drive system use a three-phase induction motor which has a three-phase stator winding and squirrel cage rotor consisting of copper or aluminum bars installed in the slots of the iron core. The bars are short circuited at each end by a copper or aluminum ring.

Variable-frequency three-phase voltages supply the stator. The three-phase currents produce a rotating magnetic field which induces a current in the short-circuited rotor bars. The interaction between the rotor current and the magnetic flux produces the driving torque. Speed of the rotating magnetic field is determined by the frequency of the supply voltage and the motor construction. The rotor speed is always a few percent less than the speed of the magnetic field because the voltage induced in the rotor becomes zero if the motor and magnetic field speeds are equal.

Because of the squirrel cage rotor, these motors need very little maintenance. The sealed construction protects against spraying water and road mud. Motor efficiency varies with speed. As an example, a 7-kW motor has a maximum efficiency of 97 percent at 6000 rpm and 82 percent at 1500 rpm. The maximum speed of the same motor is around 15,000 rpm. The

motor torque can be varied by reconfiguring the stator winding connections. The stator is delta-connected when the vehicle is at highway speed. The connection is switched to wye when a large amount of torque is needed for hill climbing or acceleration. The commercially available mechanical delta-wye switch can operate as a high-to-low gear shift.

**DC Motors.** EVs which have dc drive systems use series dc motors that have excellent speed-torque characteristics. Motor speed is proportional to the supply voltage, which simplifies the control circuit. The dc motors are less efficient than induction motors and the dc motor construction is more complicated because of the commutator. It requires regular maintenance and is sensitive to speeding and overloads. The dc motor maximum speed is less than the similarly rated induction motor. DC motors in an electric vehicle require a multispeed mechanical transmission.

The stator of a dc motor has poles with field windings. In a simple case, the rotor coils are connected in series and the end of each coil is connected to a commutator segment. The rotor winding is supplied by dc current through brushes connected to the commutator. The dc supply drives current through the field and the rotor windings, both of which generate a magnetic field. The interaction between these two fields generates a torque which tries to align the two fields. To assure continuous rotation, the commutator changes the direction of the coil current when it passes through the neutral zone.

Most dc motors are equipped with auxiliary poles, supplied by the rotor current, located close to the brushes. The poles reduce the magnetic field around the brushes to improve commutation.

The most suitable motor for electric vehicles is the series motor, where the field coil has low resistance and is connected in series with the rotor. This motor has a large starting torque but it decreases with increasing speed. This characteristic is suitable for urban driving but can produce problems on the highway. A lane change may require acceleration but the series motor torque is low at high speed. Some vehicles use compound motors, with a series and a separately excited field winding, which have higher torque at high speed.

The efficiency of series dc motors can be improved by replacing the current excited stator poles with permanent magnets. The expensive rare earth permanent magnets produce a higher magnetic field than the current excited coils, which leads to smaller and more efficient motors.

**Brushless DC Motor.** The brushless dc drive is basically a high-frequency ac synchronous drive. The motor consists of rotating permanent magnets and, typically, three or four sets of coils mounted on the stator. These coils are supplied by a dc current through electronic switches, where the coils are energized in sequence. At any given time, only one coil is energized. The rotation is generated by the force between the permanent magnet and the magnetic field generated by the energized coil. As an example, when coil one is energized, an attractive force develops between pole one and coil one. This force tries to align the energized coil with the permanent magnet. The alignment of the coil's field and the permanent magnet's field stops the rotation. To avoid this, before the field alignment occurs, the next coil is energized to maintain the driving force. The rotor position is monitored by a pickup coil. Switching time is determined by rotor position. The electronic switches energize the stator coils in a sequence to assure continuous motion. The sequential synchronous switching of the coils requires complicated electronic circuits to accurately measure the rotor position and activate the switches at the proper instants. The primary advantage of this drive is the elimination of brush friction and commutator arcing. The brushless dc motor has a higher efficiency and reliability than dc motors with brushes. Simultaneously, there is a significant increase in both the motor and the related electronics costs for the brushless dc motor. Its drives are particularly advantageous at constant high-speed driving. Most electric racing vehicles are built with brushless dc motors and drives.

Most vehicles's motors are mounted on the axle and connected to the wheels through fixed or variable ratio gears. An interesting experiment is the direct drive of the wheels with an in-wheel motor.

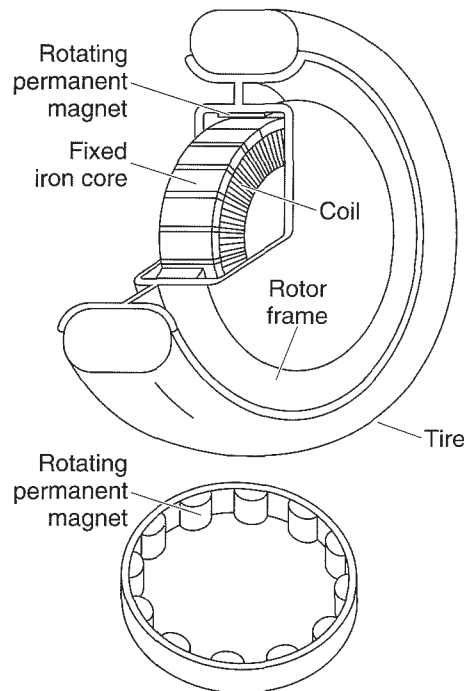

**FIGURE 30.4** In-wheel brushless dc electric motor.  
(Courtesy of Tokyo Electric Power Co.)

Figure 30.4 shows the Tokyo Electric Company's in-wheel brushless dc motor. The rotating wheels with the tiers are equipped with an array of samarium-cobalt permanent magnets. The stator coils are installed on a stationary rim which is attached to the body of the car. Four motors have been used to drive an experimental car. The lack of gears makes the control of the four motors very difficult.

#### 30.4.2 Motor Controller

The motor controller regulates the speed and torque of the electric motor, which drives the car. The motor controller also limits the motors' maximum current. Both ac and dc drive systems are used. The electric vehicle drive technology is changing continuously with the development of new electronic devices. Manufacturers are experimenting with different types of controllers that might be beneficial to EV design. The major requirements are smooth control of speed from zero to the maximum and the highest possible efficiency. Controllers should also have the capability of regenerative braking, forward-neutral-reverse control, overload/overheating protection, and production of a high starting torque.

Most dc drives use the traditional series dc motors with mechanical commutators. This well-tested motor is controlled by a simple electronic chopper (dc/dc converter). The dc motor efficiency can be improved by replacing the excitation coils with permanent magnets. However, the rare earth permanent magnets are expensive and difficult to manufacture because of the brittle nature of the material.

The latest motor development that has been incorporated into an EV is the electronically commutated brushless dc motor or ac synchronous motor, which eliminates the expense and high maintenance requirements of the mechanical commutator. These motors compete with inverter-driven ac motors. AC drives use variable-frequency inverters and three-phase induction motors. This technology is frequently used in the power industry. ac motors are inexpensive, more suitable for mass production, and are almost maintenance-free, but they do require complex electronic control circuits. Recent developments in high-power, high-current electronic devices like MOSfets and IGBTs will increase the power ratings and reduce the cost of inverters, which will increase the feasibility of using ac drives.

**DC Drives.** The concept of a commutator-type series dc motor with regenerative braking is shown in Fig. 30.5. The motor speed is controlled by regulation of the armature voltage. The system consists of two transistors or IGBT switches. Each switch is shunted by a power diode to permit the circulation of inductive current and avoid high reverse voltages across the switching devices. The diode provides a path for the armature current when the switch is off. Switch  $T_1$  operates as a chopper and regulates the average armature voltage. The motor speed is proportional to this voltage. When switch  $T_1$  is closed, the battery drives current through the

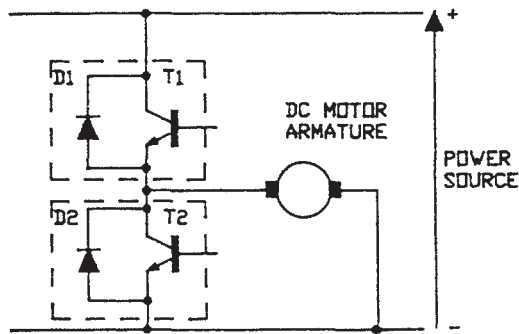

FIGURE 30.5 Concept of a commutator-type series dc motor drive.

motor. When  $T_1$  is off, the motor current circulates through the diode  $D_2$ . The motor is driven only when the switch is on. The average armature dc voltage is proportional to the switch duty cycle, which is the ratio of the switch ON time and total switching period (ON time + OFF time). The motor speed is proportional to the armature voltage and, consequently, to the chopper duty cycle.

In the regenerative braking mode,  $T_1$  is off. The motor operates as a dc generator and drives the current through diode  $D_1$  back to the battery. This charging current is regulated by switch  $T_2$ . When  $T_2$  is closed, the motor current will be diverted from the battery. The rate of recharging and braking action can be regulated by the duty cycle of switch  $T_2$ .

A more sophisticated double chopper circuit for compound dc motors is shown in Fig. 30.6. This circuit has been used in the Fiat Daily E2 van. The illustration shows the motor control cir-

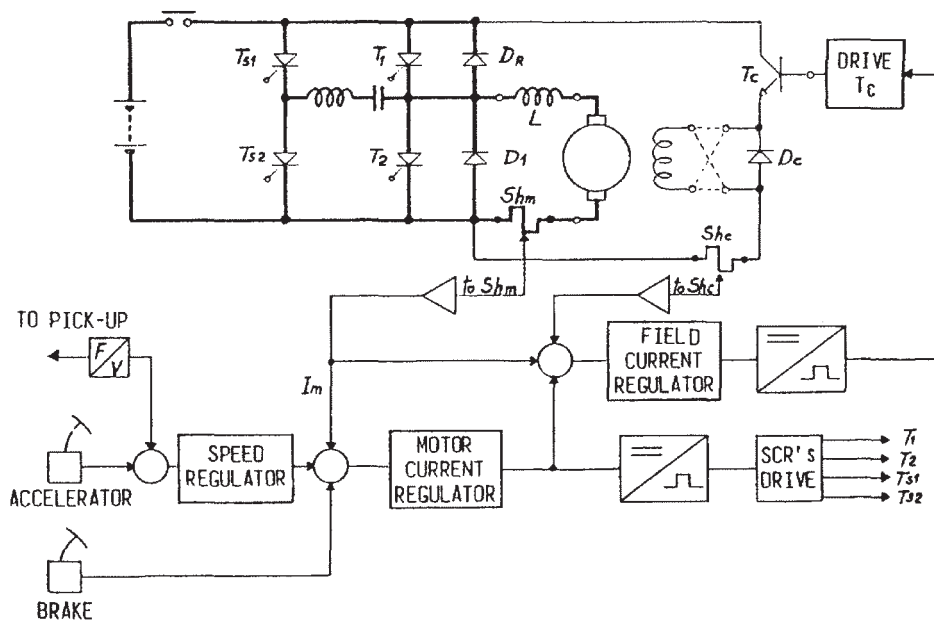

FIGURE 30.6 Double chopper for separately excited dc commutator motor.



cuit and the concept of the vehicle control. This vehicle uses a compound dc motor with a low resistance series and separate high-resistance field excitation windings. The former is connected in series with the armature while the field winding is separately excited. The armature voltage and current are controlled by a thyristor chopper, which is, in this case, a forced commutated thyristor bridge. Thyristor  $T_1$  is turned on and off to regulate the motor armature current in drive mode. Thyristor  $T_2$  is turned on and off to regulate the motor armature current in the regenerative braking mode. These thyristors are commutated by the discharge of the LC circuit through the auxiliary thyristors  $T_{s1}$  and  $T_{s2}$ . The diodes connected in parallel with thyristors  $T_1$  and  $T_2$  provide a path for the inductive motor current and eliminate the high reverse voltage. This circuit can be simplified by replacing the thyristors with high-current IGBTs.

The current of the separate field excitation winding is regulated by transistor  $T_c$ , which also operates as a chopper. The compound dc motor with the double chopper results in better speed and torque regulation.

Figure 30.6 also shows the concept of the vehicle control. Both the motor and the field excitation winding current, together with the motor speed, are monitored. The speed pickup signal and the accelerator pedal position activate the speed regulator. The speed regulator signal is compared with the motor current and the resulting signal activates the motor current regulator. The output signal of the regulator is converted to impulses that control the firing of the thyristors. A second control circuit is formed to regulate the field current. The motor current, motor current regulator output signal, and actual field currents are compared and the resulting signal controls the field current.

**Brushless DC Drives.** Brushless dc drives are the product of the latest developments in power electronics. The brushless dc motor<sup>6</sup> has permanent magnets on the rotor and coils in the stator. The elimination of the commutator from this dc motor made necessary the sensing of rotor position and sequential switching of the coils to the dc source to maintain rotation. The rotor position is sensed by a pickup coil. Each coil can be supplied either from the positive or the negative bus through a transistor switch. Each transistor is shunted by a diode to avoid high reverse voltages. The transistors are controlled from the control bus.

**AC Drives.** The ac drives use three-phase squirrel-cage induction motors supplied by a three-phase, voltage source, variable-frequency inverter using three-phase sine wave pulse-width modulation (PWM) voltage control. The motor speed is regulated by the variation of the supply voltage frequency. The change in voltage regulates the magnetic flux in the motor, which affects the motor torque and current. Regulation of the motor speed, torque, and current requires the simultaneous regulation of frequency and amplitude of the motor supply voltage. The most simple method is to maintain a constant supply voltage and frequency ratio. The voltage amplitude is controlled by pulse-width modulation (PWM).

The concept of ac motor regulation is shown in Fig. 30.7. The voltage source inverter consists of three parallel connected switching units. Each unit contains two switches connected in series. Each switch is built with a semiconductor device (transistor, IGBT, etc.) and a diode connected in parallel. The diode provides a path for the motor inductive current and eliminates dangerous reverse voltages across the switching devices.

The three-phase voltage, without PWM, is generated by the sequential operation of the switches. In each instance, three switches located in different branches, are turned on. As an example, switches  $Q_1$ ,  $Q_2$ , and  $Q_3$  can be turned on simultaneously. This connects the negative battery terminals to phase "c" and the positive terminals to phases "a" and "b." The simultaneous turn-on of switches  $Q_1$ ,  $Q_4$ , and  $Q_6$  is a prohibited combination because the simultaneous turn-on of  $Q_1$  and  $Q_4$  short circuits the battery. The turn-on of the switches is shifted from each other by 60 degrees and each switch conducts for 180 degrees. The turn-on gating signals are shown in Fig. 30.8. In each cycle, the switches are turned on in the following order: 123, 234, 345, 456, 561, and 612. It can be seen in Fig. 30.8 that this circuit produces square shape voltages and does not permit the regulation of the motor current. It can be regulated and circuit performance improved by using PWM when each switch is operated several times during each half cycle.

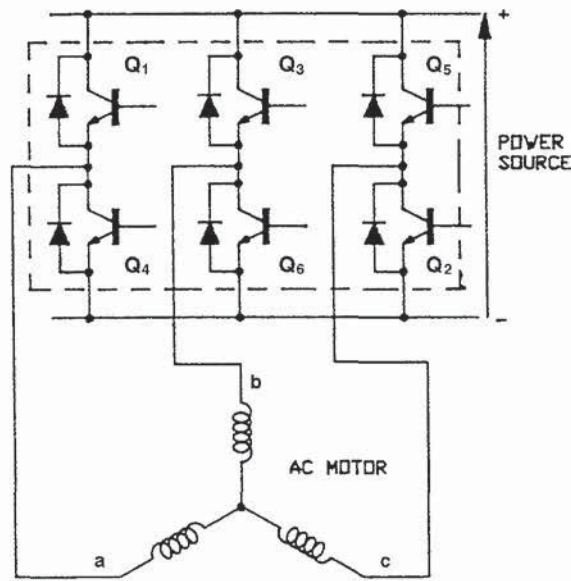

FIGURE 30.7 Concept of ac motor regulation.

The on and off time of the switch is determined by the comparison of a sinusoidal input signal with a triangular carrier signal. When the carrier amplitude is higher than the sine wave's amplitude, the switch is on; when it is lower, the switch is off. The described switch operation generates a pulse train of variable width at the terminals of the motor. The motor inductance integrates the variable-length voltage pulse train. Due to this integration effect, the variable-length pulse train drives a practically sinusoidal current through the motor. The widths of the output voltage pulses and the motor current are regulated by variation of the input sine wave amplitude. The described PWM method eliminates most of the harmonics from the motor current and results in a high-efficiency operation over a wide range of speeds. The expected peak efficiency is around 85 to 91 percent. These drives are particularly well suited for urban driving.

**Switching Devices.** The key component in both ac and dc drive systems is the semiconductor switching device. The device ratings for cars with a 40 to 50 kW drive and variable ratio transmission must be about 200 V and 250 A and for cars with fixed-ratio transmission, 400 to 600 V and 400 to 500 A.<sup>7</sup>

The advanced motor controllers should operate at a frequency between 10 and 20 kHz. High-frequency operation reduces the electronically generated audible noise. The disadvantage is the increase in switching losses and the generation of rf disturbances. The time of the transition from ON to OFF or OFF to ON state is important. The shorter transition time reduces the switching losses. Due to the wiring inductance, the fast switching may generate short duration overvoltages, which may be detrimental to the semiconductors. These overvoltages are controlled by selecting short leads and using filters or snubber circuits. The desired switching time is less than one microsecond.

**Thyristor or Silicon Controlled Rectifier (SCR).** SCRs have been used by the power industry for years in variable-speed drives. They have a large current-carrying capacity and high voltage ratings and relatively low voltage drop, but the current flow cannot be controlled after

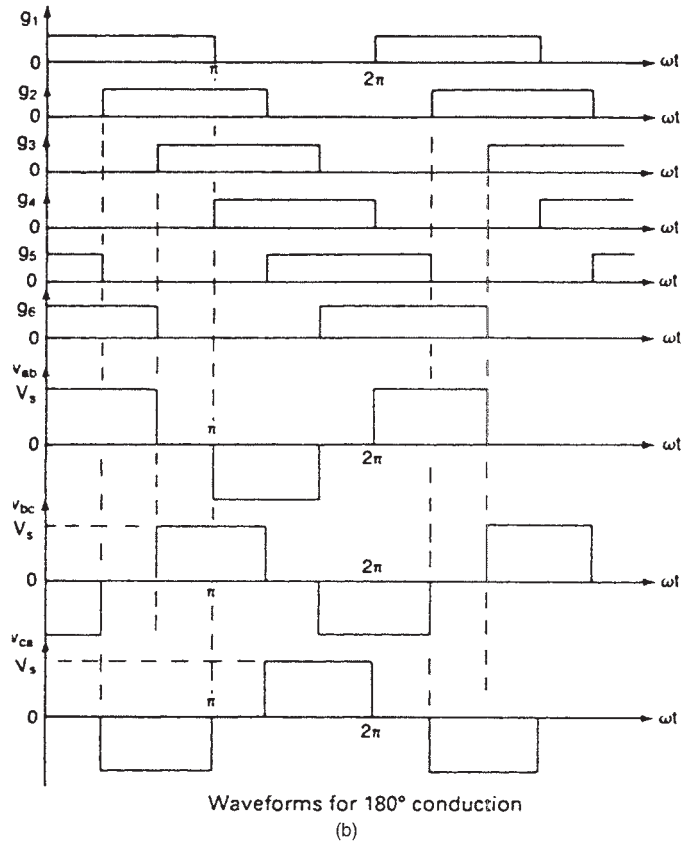
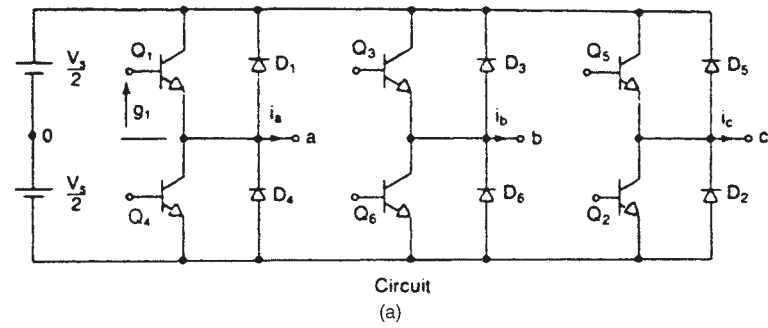

FIGURE 30.8 Three-phase voltage-controlled inverter operation.

firing. The turn-off requires cumbersome auxiliary circuits. In spite of these disadvantages, some EVs use SCRs.

**Gate Turn-Off Thyristor (GTO).** The gate turn-off thyristor can be turned off by a powerful gate signal. The problem is that the device can only operate at low frequencies (1 to 5 kHz) and the voltage drop is significantly higher than the SCR's voltage drop. Also, the firing and turn-off require large currents, which increase losses in the device.



**Power Transistors.** Both the voltage drop and the gain of power transistors are low. The low gain requires expensive gate drive systems. The transistors can operate in the required audio frequency range. The performance can be improved by connecting two transistors in a Darlington pair configuration. In this connection, the first transistor serves as an amplifier, which permits control of the device with low current. The Darlington connected transistors are sold as a unit at an attractive price. This is a frequently used circuit.

**Power MOSFET.** The MOSFET is a voltage-controlled device as compared to current-controlled (thyristor/transistor) and is designed for high-frequency operation. However, the saturation voltage drop and its temperature sensitivity limit the MOSFET application in power circuits.

**Insulated Gate Bipolar Transistor (IGBT).** The IGBT is a transistor which is controlled by a MOSFET. The IGBT requires low drive current, is suitable for high-frequency operation, and has a fast switching time. Disadvantages are that the device voltage drop and cost are higher than the Darlington transistor configuration. The large current capability and operating voltage, together with the low power drive circuit, makes the IGBT attractive for electric vehicles.

**MOS-Controlled Thyristor (MCT).** The MCT has a low voltage drop and can be turned on and off with a voltage signal (low switching losses). It can also be designed for high-voltage and high-current applications. This new device is very attractive for EVs.

The semiconductor industry frequently produces better and more powerful semiconductor switches which have potential for EV applications. The typical ratings of the most frequently used devices are shown in Table 30.3.<sup>6</sup>

### 30.4.3 Mechanical Drives

Lack of high-speed acceleration and the efficiency problems can be mitigated by the use of mechanical gears, similar to those used in today's ICEVs. The efficiency of an EV drive depends on the speed. Typically, ac drives operate at better than 80 percent efficiency in the range of 2000 to 12,000 rpm and the series dc drives in the 2000 rpm to 5000 rpm range. The brushless dc drives' efficiency is better than 85 percent in the 3000 to 8000 rpm range.

Another consideration is torque-speed characteristics. Most drives keep the motor torque more or less constant, in the 0 to 4000–5000 rpm range. However, at higher speeds, the torque begins to decline. This means that acceleration in the 65 to 105 km/h range is poor. This may create problems during highway driving.

These examples show that the efficient operation of electric drives requires more than 2000 to 3000 rpm, but the wheel speed at 105 km/h highway speed is only about 500 rpm. Frequent acceleration is characteristic of city driving, which requires high torque. In spite of the advancement in electronic drive technology, efficient EV operation requires mechanical gears to reduce motor speed. Typically, a gear ratio is between 4:1 and 8:1.

**TABLE 30.3** Comparison of Power Switching Devices

	Darlington BJT	Power MOSFET	IGBT	MCT
Power capability	1200 V, 800 A	500 V, 50 A	1200 V, 400 A	600 V, 60 A
Gating	Current	Voltage	Voltage	Voltage
Conduction drop, V	1.9	3.2	3.2/1.7*	1.1
Switching frequency, kHz	10	100	20/40*	20
Reapplied $dv/dt$ , V/ $\mu$ s	Limit for device loss and SOA	Limited by Miller effect	Limit for device loss	5000
Turn-on $di/dt$ , A/ $\mu$ s	100	Very high	Very high	1000
Turn-on time	1.7 $\mu$ s	90 ns	0.9 $\mu$ s	1.0 $\mu$ s
Turn-off time	5 $\mu$ s	0.14 $\mu$ s	1.4 $\mu$ s/200 ns*	2.1 $\mu$ s

\* Second generation.

**Multiratio Variable Drives.** The multiratio variable drive utilizes present automotive technology, where motor speed is regulated with an automatic or manual transmission and the wheels are driven by a differential gear for further speed reduction. Most converted EVs use the same transmission and differential originally designed for the ICEV. In these vehicles, the internal combustion engine is replaced by an electric motor. However, the multiratio (manual transmission) variable gear is used in some of the cars designed specifically for electric operation. A typical example is the Fiat Panda Electric which has only a 9.2-kW motor with a manual four-speed transmission plus reverse gear. The multiratio variable-speed mechanical drives are used frequently in connection with series dc motor drives. These drives have a relatively narrow range of efficient operation. The multiratio gear permits the more accurate matching of the electric drive characteristics with different operating conditions.

**Single-Ratio Drives.** Some of the electric drives, like variable-frequency ac drives, have a broad range of efficient operation. A single-ratio reduction gear can match the drive characteristics with road conditions. Most vehicles designed for electric operation use this technique. The motor is mounted on the axle and the reduction gear is integrated with the motor. A typical example is the Ford Ecostar. In this vehicle, a 75-kW induction motor is mounted directly on the front transaxle.

An example of the integration of the motor and reduction gear is the transaxle-mounted motor<sup>8</sup> shown in Fig. 30.9. The maximum speed of the permanent magnet motor is 7500 rpm. A 7.5:1 ratio gear and a planetary differential, mounted on the motor, drives the wheels with a reduced speed. This transaxle arrangement matches the motor with road conditions.

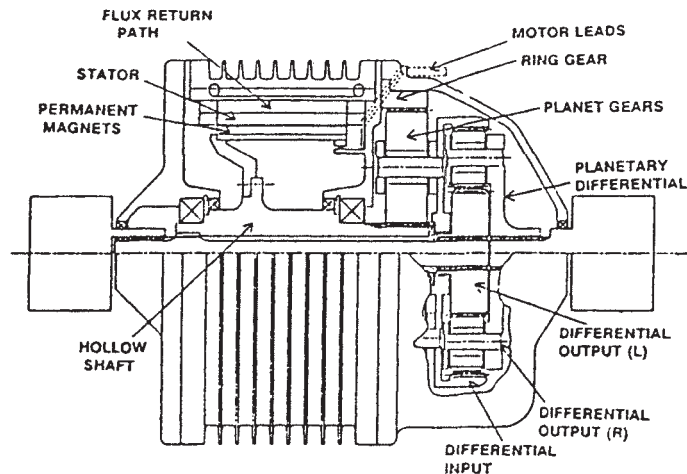

FIGURE 30.9 Integrated transaxle motor, gear, and differential arrangement.<sup>8</sup>

**Direct Drives.** The direct driving of the wheels by in-line motors is a desirable concept for EVs. An in-wheel drive eliminates gears and simplifies the mechanical construction of the vehicle, but it requires complicated electronic controls and sacrifices some vehicle performance. A typical example of in-wheel drive is shown in Fig. 30.4, where the motor is mounted directly on the wheel. The performance of direct drives can be improved by modifications to the motor connection by a switch. Typical solutions are a switch from delta to wye connection and a switch from series to parallel connection in a motor with two windings.



### 30.5 BATTERY

For the EV to become a viable option for transportation, the primary technological issue which must be improved upon is energy storage. Short range and long charging times have daunted EV design efforts since the early 1990s. The lead-acid battery, which has not improved much since the early EVs, is the only readily available and inexpensive battery technology available today.

In order to address the issues involved with the research and development of new battery technologies, major United States automobile manufacturers (Ford, Chrysler, and General Motors) created the United States Advanced Battery Consortium (USABC).<sup>9</sup> In 1992, the USABC working with the government began a \$260 million project to develop more efficient energy storage systems for use in EVs. Since the lead-acid battery did not hold promise for EV use in the long run, its development was not addressed by USABC. But since lead-acid batteries are used extensively in current EV designs, another group—The Advanced Lead-Acid Battery Consortium (ALABC)—was formed to work with the government and industry in further development of lead-acid batteries for EVs.

#### 30.5.1 EV Battery Requirements

EV batteries have the following requirements: high specific energy, high specific power, high efficiency, long cycle life, low cost, safety, reliability, maintenance free, reasonable recharge time, and recyclable materials. Since current batteries have deficiencies in many of the requirements, the motivation is strong to develop a battery that will meet most, if not all, of the requirements.

#### 30.5.2 Battery Characteristics

Specific energy (energy density) is the most commonly used specification for batteries. It denotes the energy capacity per unit weight for a given battery, which normally relates to the driving range of the battery pack. To derive the specific energy, the total energy which can be removed from the battery for a given discharge profile is divided by the total weight of the battery. The ohmic losses (due to  $I^2R$  heating from internal resistance and contact resistances) and chemical energy losses represent energy which is stored in the battery during charging but not available during the discharge cycle. The energy efficiency is the ratio of the available energy for discharge to the total stored energy.

The specific power (power density) represents the maximum power that the battery can deliver, which is an indication of the battery's ability to perform under EV acceleration and hill climbing. Specific power will vary depending on the test parameters (DOD, current, age of batteries, etc.).

Table 30.4 lists characteristics of different battery technologies currently available and those under development.<sup>6</sup>

**TABLE 30.4** Comparison of Battery Technologies (Relative to Lead-Acid)

Battery	Pb-acid	Ni-Fe	Ni-Cd	Ni-MH	Zn-Br	Na-S	Li-FeS <sub>2</sub>	Li-Poly
Relative energy density	1.0	1.5	1.6	1.7	2.2	2.5	4	4
Relative peak power density	1.0	1.2	1.9	2.1	0.6	1.1	4	3.5
Relative range	1.0	2.0	2.1	2.3	2.1	3.4	4	4
Energy efficiency, %	68	58	80	76	75	91	80	85

### 30.5.3 Battery Technologies

This section will cover battery technologies which are currently in use and those which are still under development.

**Lead-Acid.** The lead-acid batteries are still the most commonly used for EVs today. Efforts are underway for the development of advanced lead-battery concepts for the short-term requirements of EV energy storage. A metal plate used in a liquid electrolyte configuration is the most inexpensive battery on the market today. Lead-acid batteries have a specific energy of about 35 Wh/kg and specific power of 93 W/kg.

**Ni-Fe Battery.** Another metal plate in liquid electrolyte battery is the Ni-Fe battery which has a much longer cycle life than the lead-acid battery. The Ni-Fe battery is very robust but has a relatively small specific energy and specific power. It requires water to be added during each charging cycle (high maintenance), which means the battery cannot be sealed. Hydrogen release is also a problem and complicates the design of Ni-Fe battery equipped EV. The Ni-Fe battery is also expensive and has a specific energy of about 50 Wh/kg and a specific power of about 100 W/kg. Since the Ni-Fe battery has been extensively developed, it seems less likely that there will be a major breakthrough for its technology than for other newer technologies.

**Ni-MH.** The nickel metal hydride batteries show promise for EV application. They use one nickel hydroxide electrode and one metal alloy electrode which has the property of being able to store hydrogen in the solid state. Typically the Ni-MH battery has specific energy and specific power of 54 Wh/kg and 174 W/kg, respectively. It also has a relatively long cycle life. The specific energy of one experimental Ni-MH battery is 81 Wh/kg.<sup>2</sup>

**Zn-Br.** The Zn-Br battery uses carbon electrodes and pumps the electrolytes (zinc bromide/zinc bromide + bromine) to separate sides of the cell. Pumping of the electrolytes provides cooling and uniform plating of the electrode. The Zn-Br battery has a high energy density (72 Wh/kg), but a relatively low power density (53 W/kg). Because of the high energy density, the research will probably continue on the Zn-Br battery, but problems with low power density, higher cost (pumps, reservoirs, and lines), and the corrosive nature of the materials used will make it unlikely that this battery will be the long-term solution for EV use.

**Na-S.** The sodium-sulphur battery does not have solid electrodes. It uses molten sodium (heated to 300 °C) as the electrode. The Na-S battery has a specific energy of 80 Wh/kg and a specific power of 100 W/kg. A distinct advantage of the Na-S technology is its long self-discharge time, which can be years. It comes about because the electrolyte is an insulator which allows only migration of sodium ions and not electrons. A long self-discharge time would be advantageous in any EV application where long periods must be tolerated without a recharge. High operating temperature and hazardous materials (sodium and sulphur) would require rigid packaging requirements (crashworthiness) for the Na-S battery, which would add substantially to the cost. Another drawback is the possibility of the molten sodium electrode solidifying after a period of nonoperation. The addition of heaters for the battery will also add additional cost. And continual solidifying and reheating of the electrode will eventually damage the battery.

**Lithium-Based Technologies.** Lithium-based electrode batteries (lithium-iron sulfide, lithium-iron disulfide, and lithium-polymer) show promise for future EV use. Extensive research is underway. Heat dissipation during charging and discharging and manufacturing issues are fundamental problems which must be addressed.

### 30.5.4 Future of Battery Development

The USABC has projected goals for the development of new battery technologies. These goals have been divided into two categories: midterm and long-term. Table 30.5 lists the goals set by the USABC.<sup>6</sup>

**TABLE 30.5** Midterm and Long-Term Objectives of the USABC

Criteria	Midterm	Long-Term
<i>Primary criteria</i>		
Power density, W/L	250	600
Specific power, W/kg (80% DOD/30 s)	150* (*200 desired)	400
Energy density, Wh/kg (C/3 discharge rate)	135	300
Specific energy, Wh/kg (C/3 discharge rate)	80* (*100 desired)	200
Cycle life, cycles	600 (5 years)	1000 (10 years)
Ultimate price, US\$/kWh	<150	<100
Operating environment, °C	-30 to +65	-40 to +85
Recharge time, h	<6	3 to 6
Continuous discharge, % of rated energy capacity (no failure)	75	75
<i>Secondary criteria</i>		
Efficiency, % (C/3 discharge, 6 h charge)	75	80
Self-discharge	<15% in 48 h	<15% per month
Maintenance	Zero	Zero

## 30.6 VEHICLE CONTROL AND AUXILIARY SYSTEMS

### 30.6.1 Vehicle Controller

In addition to the motor drive, the EV has several other systems which must be monitored and controlled. Figure 30.10 shows the block diagram of a vehicle control system. It is divided into four major parts: motor controller, pedals, hand controls, and dashboards. The advanced system uses a microprocessor to monitor all subsystems. Quantities like temperature, speed, current, and voltage—which are relevant to the subsystem operation—are measured with transducers that convert operating conditions to analog signals. The signals are then digitized and supplied to the microprocessor. It evaluates the subsystem signals and sends out control signals. The microprocessor also shuts down the system in case of a fault. The vehicle controller also assures close to optimal operating conditions and optimal use of energy stored in the batteries. The batteries' condition is monitored and the available approximate mileage range is reported to the driver.

### 30.6.2 Climate Control System

The air conditioner and heating system consumes a considerable amount of power. The Ford Ecostar equipped with a 75-kW motor and its heater, for example, consumes 5 kW and its air conditioner, 6 kW.<sup>2</sup> This is particularly significant considering that the same vehicle requires about 8 kW of power when driven in accordance with the Federal Urban Driving Schedule. The use of the air conditioner or heater significantly reduces the vehicle range.

**EV Air Conditioner.** A car's air conditioning system is designed to operate, typically, at outside temperatures of 44 °C and a relative humidity of 40 percent. The air conditioner cools the

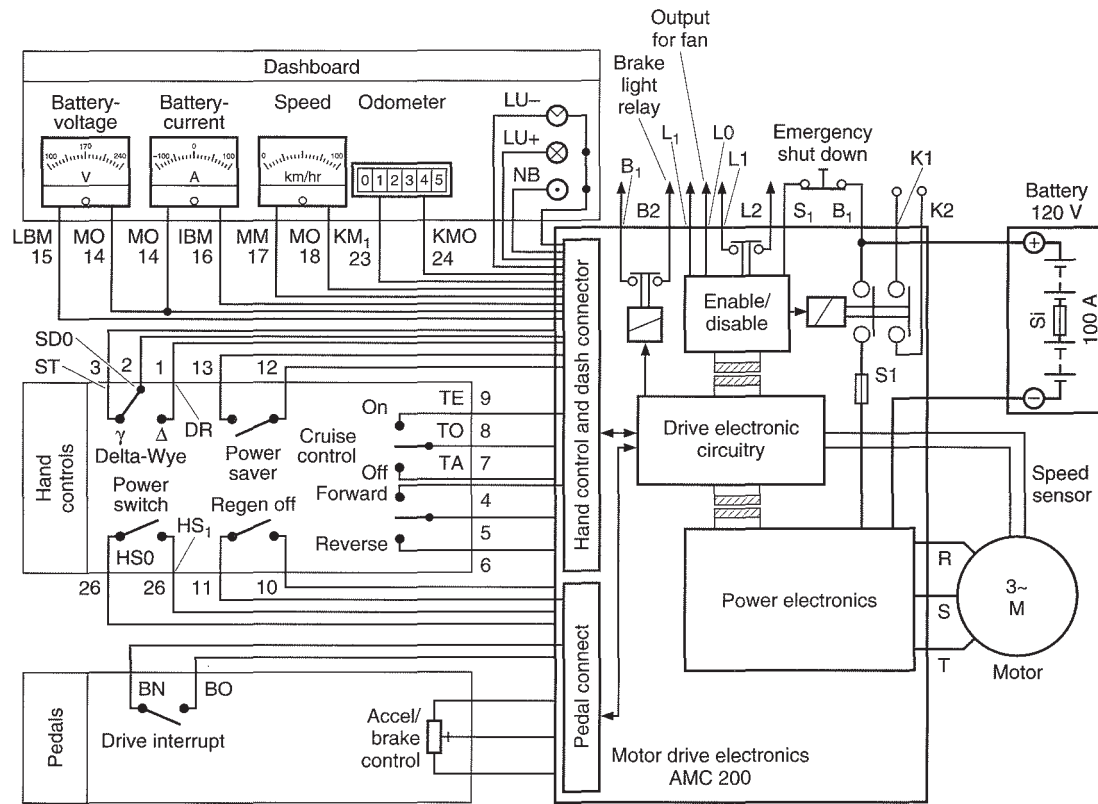

FIGURE 30.10 An electric vehicle control system.

inside of the vehicle to 27 °C and a relative humidity of 50 percent. The interior of the vehicle must be ventilated and this increases the air conditioning system heat load. The ANSI/ASHRAE 62-1981R “Ventilation for Acceptable Indoor Air Quality Code” requires 15 ft<sup>3</sup>/min ventilation air per passenger. The finished car interior provides sufficient heat insulation, but EV side windows must be tinted and doors must be properly sealed to reduce heat loss.

A typical air conditioning system has relatively low efficiency, which reduces vehicle range considerably. Several research projects have dealt with the development of more efficient systems. The most promising concept is shown in Fig. 30.11. This system is built with a variable-speed compressor driven by a brushless dc motor. The compressor increases the coolant pressure and temperature. The coolant then expands in the expansion tube and evaporates in the evaporator, thus reducing its temperature. The evaporator coils cool the air, which is blown into the interior of the car. A variable-speed drive improves the air conditioner performance. Tests indicate, however, that better roof insulation, the use of wavelength-selective window tinting, and cooling of the parked vehicle by a small 20-W fan reduce the air conditioning thermal load and permit the use of a smaller and lighter unit.

**EV Heating.** Current EVs use liquid fuel heaters, which are expensive and pollute the air, and the use of two fuels in a vehicle is not desirable. An alternative heating method is the use of the air conditioner as a heat pump, together with vehicle waste heat. In extreme conditions, the system can be supported by additional electric resistance heaters. Unfortunately, such a heating system also reduces vehicle range.



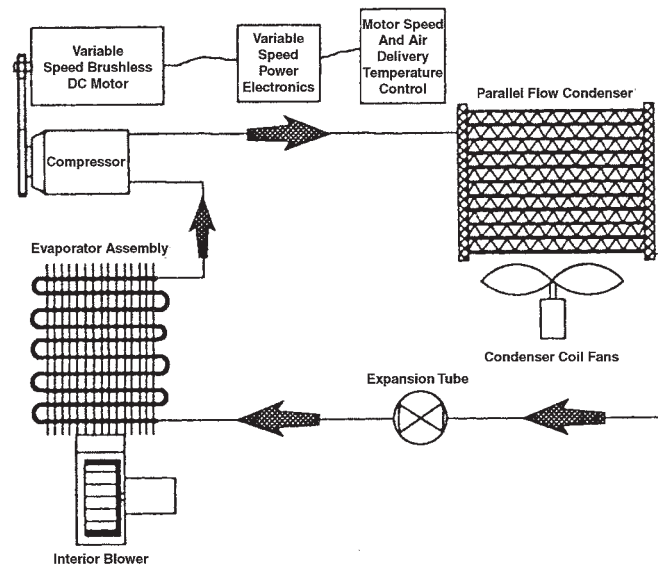

FIGURE 30.11 An EV advanced air conditioning system.<sup>10</sup>

### 30.6.3 Auxiliary Power

Proper operation of the vehicle requires an electric supply for power steering, power brakes, the headlights, turn indicators, etc. All these systems are well developed and optimized for ICEVs. Supply of the auxiliary equipment with more than 100-V batteries jeopardizes electric safety. Higher voltage requires better insulation and increases costs. Consequently, most electric vehicles have a 12-V auxiliary power supply and distribution system. One solution is a chopper, which charges a normal 12-V battery. Another solution is a constant voltage switching power supply like those used in the electronics industry.

## 30.7 INFRASTRUCTURE

The increasing use of ICEVs initiated the development of a highway system, the network of gas stations, the gas distribution system, and the increased production of high-quality grades of gasoline. Most of these facilities, except the gas supply and distribution, will be used by EVs. The electrical network is well developed, but the refueling of large numbers of vehicles may require an increase in network capacity.

### 30.7.1 Electric Network Reinforcement

The EV can be charged slowly overnight at the owner's home or it can be charged at charging stations at a much faster rate. The method of charging has a major effect on the electric system requirements.

**Slow Charging.** EVs are charged from the local electric distribution system. The present concept<sup>2</sup> is that EVs will be charged at the owners home during off-peak hours (overnight).



This requires 5 to 10 hours from a 240-V, 30-A outlet. Also, credit card or coin-operated charging facilities will be installed in public parking lots and garages. These facilities will charge the vehicles with 30 to 50 A to provide a partial recharging while the vehicle is parked. Slow overnight charging will improve utilization of the electric network and does not require network reinforcement. But daytime charging of large numbers of EVs will increase the peak load and require both generation and distribution system improvement. The utilities will use time-of-day pricing, in which the night rate is significantly lower than the day rate. The use of interruptible tariffs may be considered. This would allow the utility to interrupt the vehicle charging by a remote signal during peak hours. In both cases, the customer is charged with a lower rate.

**Quick-Charging.** In the future, high-capacity quick-charging stations will be available to the EV user. Quick-charging will require several hundred amperes and special equipment, which is currently under development. The large charging current will produce high peak loads on the local distribution system. To reduce these loads, the use of energy storage devices is being considered. These include batteries, flywheels, and superconducting magnetic storage systems. Quick-charging stations will not be designed to fully charge a discharged battery, but will provide an additional 110 to 160 km of driving range with a 10- to 30-min charge.

It can be visualized that quick-charging stations will be similar to today's gas stations. They will be located along highways where the electric distribution system is weak. The utility distribution system must be reinforced if quick-charging is to be used.

### 30.7.2 Harmonics and Power Factor

EV chargers are electronic devices that generate harmonics and consume reactive power. Expected operating conditions in a future slow-charging station can be estimated from the measurements performed during the APS Electric 500 Race in Phoenix, Arizona, in 1994. Figure 30.12 shows the supply cable current when 30 different vehicles were charging.<sup>11</sup> The maximum charging current per vehicle was limited by a circuit breaker to 50 A at 240 V. The figure shows severe harmonic distortion.

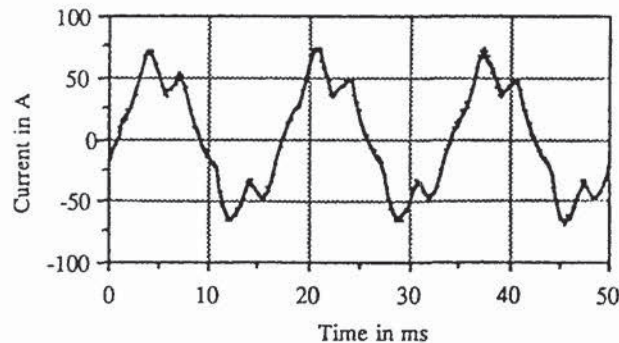

FIGURE 30.12 Charging current waveform at a slow-charging station.<sup>11</sup>

The measured power factor for the different chargers varied between 0.75 to 1. The cumulative distribution of the power factor at the supply cable shows that 50 percent of the chargers had a power factor less than 0.86.

The measured harmonic distortion factor was between 5 and 50 percent. The cumulative distribution of the harmonic distortion factor at the supply cable shows that 80 percent of the

chargers operated with a distortion factor less than 30 percent.<sup>11</sup> The measured values are alarming and indicate the need for improvement.

Reactive power consumption can be reduced by the use of a voltage source type rectifier for charging. This circuit uses transistors instead of diodes or thyristors. The transistors are switched in such a way that the voltage and current are in phase. Another technique for reactive power control is to use phase correction capacitors.

The harmonic content of current in a charging station can be significant but it can be reduced by the use of pulse-width modulation (PWM) at the chargers. This method also requires transistors and a significantly more complicated control circuit. The current harmonic content in a charging station decreases as the number of vehicles being charged simultaneously increases. This is due to the phase shift between the harmonics being generated by the different types of chargers. The phase shift provides cancellation of harmonics.<sup>11</sup> Nevertheless, the harmonics generated by large numbers of EVs may produce significant problems for utilities.

### 30.7.3 Magnetic Field Generation

The current in an EV can be a few hundred amperes. It produces magnetic fields both inside and outside the EV. The magnetic field generated by the dc drives has both dc and ac components. The ac component is superimposed on the much higher dc component. The ac drive produces magnetic fields, which are distorted sine waves. The fundamental component is determined by the speed of the vehicle. The higher-frequency components up to the tenth harmonic are not negligible.

The highest magnetic field was measured during acceleration and regenerative braking. In this condition, the maximum field in the engine compartment was about 120 mG. The magnetic field in the passenger compartment was negligible due to the shielding effect of the car body.<sup>12</sup>

The magnetic field in a future charging station can be estimated from the measurements performed during the 1994 APS Electric 500 Race. The results indicate that the highest field around 50 mG was measured near the charging cables. The field 50 cm from the vehicles was between 20 and 30 mG.<sup>13</sup> Numbers suggest that the future charging station design has to consider the use of shielded cables and cable arrangements with low field emission.

## 30.8 HYBRID VEHICLES

---

The inherent low operating range of EVs suggests the building of hybrid vehicles with both electric and gas systems. Hybrid vehicles are equipped with an internal combustion engine and an electric motor drive and battery. In highway driving between cities, where the pollution is not critical, the car is driven by the internal combustion engine (ICE), which also charges the battery. In the city, the electric motor and drive are used. The operation can be improved by recharging the battery at night.

The two basic configurations for hybrid vehicles are series and parallel. Figure 30.13 shows two conceptual arrangements for hybrid vehicles.

### 30.8.1 Series Hybrid Drive

In a series hybrid drive, the ICE drives a generator, which charges the battery and supplies the electronically controlled motor. The electric motor propels the car. In this system, the ICE operates at constant speed with maximum efficiency. The vehicle is controlled electrically. The electric control simplifies the mechanical gears and differential. The disadvantage of this

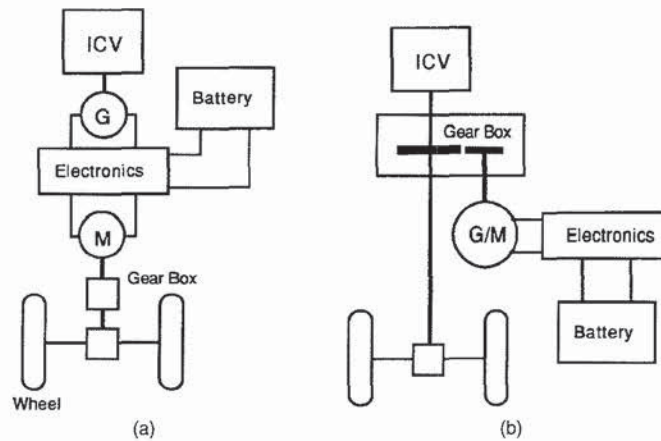

**FIGURE 30.13** Two conceptual arrangements for hybrid vehicles: (a) series hybrid drive; (b) parallel hybrid drive.

arrangement is that both the ICE and the electric drive have to be rated to the maximum power. Another problem is low overall system efficiency.

### 30.8.2 Parallel Hybrid Drive

The parallel system consists of an ICE and an electric drive connected by a mechanical gear. The electric drive is built with a motor/generator, electronic control, and battery. The mechanical gear drives the wheels through a differential. In highway driving, the ICE propels the vehicle and charges the battery. The electric motor operates as a generator. In city driving, the battery and the electric motor drive the vehicle. During hill climbing or other conditions when the maximum power is needed, both engine and motor drive the vehicle. This arrangement results in better efficiency, less weight, and lower cost.

Hybrid vehicle technology is under development with several other arrangements which have been proposed and are being evaluated. Volkswagen built a city taxi<sup>14</sup> which performed well during a 100,000-km test. The problem with this vehicle is the weight. Today's lead acid batteries added 200 to 300 kg to the vehicle's weight.

## GLOSSARY

**Battery** Self-contained electrochemical cell/cells or system which converts chemical energy to electrical energy in a reversible process.

**Battery technologies** Ni-Fe (nickel-iron), Ni-Cd (nickel-cadmium), Ni-MH (nickel-metal hydride), Zn-Br (zinc-bromine), Na-S (sodium-sulphur), Li-FeS<sub>2</sub> (lithium-iron disulfide), Li-Polymer (lithium-polymer).

**Brush** Conductor used to maintain an electric connection between the moving and stationary parts of a motor.

**Capacity** Energy storage capability of the battery.



**Charge/discharge profile** Different charging/discharging schemes used for evaluation of a battery.

**Commutator** Mechanical switch which transfers current from one coil to another at the proper instant.

**Depth of discharge (DOD)** Percentage of capacity (ampere-hours) which has been removed from the battery.

**Electric drive system** The motor, motor controller, and cabling used to drive an electric vehicle.

**Electric vehicle (EV)** Automobile, truck, or any vehicle powered by rechargeable or non-rechargeable batteries and an electric motor.

**Electrolyte** Medium in which current flows by movement of charged particles (ions).

**Gear box** Gear that reduces the speed of a motor by connecting together different ratios of gears.

**Inductive coupling** The association of two or more circuits by means of inductance mutual to the circuits.

**Phase-controlled rectifier** A converter for conversion from ac to dc that varies the point within the cycle at which forward conduction is permitted to flow through the semiconductor elements.

**Quick-charging** Charging batteries at a rate that will produce a 40 to 50 percent charge in about 15 minutes.

**Regenerative braking** Capability of an electric drive to return the kinetic energy, stored in the velocity of the EV body, to the battery during braking.

**Specific energy (energy density)** A battery's energy storage capability per unit weight (Wh/kg).

**Specific power (power density)** Power delivery capability per unit weight of a battery (Wh/kg).

**Squirrel-cage rotor** A rotor winding consisting of conducting bars connected by metal rings or bars at each end.

**State of charge (SOC)** The battery level of charge can be stated as either DOD or SOC.

**Transaxle** An axle that includes the differential and gear box.

## REFERENCES

1. H. H. Braess and Regart, K. N., "Electrically propelled vehicles at BMW—experience to date and development trends," *Electrical Vehicles Design and Development*, SP-862, #910245, Society of Automotive Engineers Inc., Warrendale, Pa., Feb. 1991, pp. 53–62.
2. M. J. Riezenman, "Electric vehicles," *IEEE Spectrum*, Nov. 1992, pp. 18–24.
3. T. Moore, "Charging up for electric vehicles," *EPRI Journal*, June 1993, pp. 7–17.
4. P. Wuebben, Lloyd, A. C., and Leonard, J. H., "The future of electric vehicles in meeting the air quality challenge in southern California," *Electrical Vehicles Design and Development*, SP-817, #900580, Society of Automotive Engineers Inc., Warrendale, Pa. Feb. 1990, pp. 107–120.
5. S. Ohbe, "Determining component specifications for conventional on-road electric vehicles," SP-817, pp. 67–72 (see Ref. 4).

6. C. C. Chan, "An overview of electric vehicle technology," *Proceedings of the IEEE*, vol. 81, no. 9, Sept. 1993, pp. 1302–1313.
7. P. E. Morris and Adams, D. S., "Design considerations and component selection for volume-produced EV controllers," SP-817, pp. 85–97 (see Ref. 4).
8. W. M. Anderson and Cambier, C. S., "Integrated Electric Vehicle Drive," SP-862, pp. 63–68 (see Ref. 4).
9. "Electric vehicle research draws batteries of ChE's," *Chemical Engineering Progress*, Feb. 1993.
10. J. Dieckmann and Mallory, D., "Climate Control for Electric Vehicles," SP-862, pp. 101–110 (see Ref. 4).
11. G. G. Karady, Berisha, S. H., Blake, T., and Hobbs, R., "Power quality problems at electric vehicle's charging station," SP-1023, #940297, Society of Automotive Engineers Inc., Warrendale, Pa., Feb. 1994, pp. 31–37.
12. G. G. Karady, Berisha, S. H., Hobbs, R., and Demcko, J. A., "Electric vehicle magnetic field measurement," SP-984, #931790, Society of Automotive Engineers Inc., Warrendale, Pa., Aug. 1993, pp. 13–15.
13. G. G. Karady, Berisha, S. H., and Muralidhar, M., "Low frequency magnetic field generated at electric vehicles charging station," SP-1023, #940298, Society of Automotive Engineers Inc., Warrendale, Pa., Feb. 1994, pp. 39–45.
14. A. Ksilberlah, "Electric hybrid drive for passenger car and taxis," SP-862, pp. 69–78 (see Ref. 4).

### ABOUT THE AUTHORS

GEORGE G. KARADY is Salt River Project Chair Professor at Arizona State University, where he is responsible for the electric power education and performs research in power electronics and high-voltage engineering. He is the chairman of the IEEE Subcommittee on Lightning and Insulator and WG on Non-Ceramic Insulators. He is the author of more than 60 technical papers.

TRACY BLAKE is currently pursuing the Ph.D. in power engineering at Arizona State University. He previously worked as an electrical engineer for SYRE, a support service contractor to NASA. His research interests include HVDC and electric vehicle technology.

RAYMOND S. HOBBS is a senior research engineer in the R&D department at Arizona Public Service Co. He is the coauthor of several papers on electric vehicles and serves on the Electric Vehicle Infrastructure Working Committee of the Electric Power Research Institute.

DONALD B. KARNER is an independent consultant and president of Electric Transportation Applications, specializing in the infrastructure development required to support growth of electric vehicle use. He is project manager for the Safety of Electric Racing Vehicles Project, an effort to provide safety and logistical support to electric vehicle competitions.



---

# CHAPTER 31

---

## NOISE CANCELLATION SYSTEMS

---

**Jeffrey N. Denenberg**

*Vice President of Engineering*

*Noise Cancellation Technologies, Inc.*

Active noise cancellation is not a new idea. Creating a copy of the noise and using it to cancel the original dates back to the early part of this century. The first systems used a simple “delay and invert” approach and showed some promise, but the variability of real-world components limited their effectiveness.

In the mid-1970s, a major step forward took place with the application of adaptive filters to generate the antinoise. This greatly enhanced the effectiveness of the systems, because they could continuously adapt to changes in their external world as well as changes in their own components. A second breakthrough in the mid-1970s was the recognition that many noise sources, particularly those produced by man-made machines, exhibit periodic or tonal noise. This tonal noise allows a more effective solution, because each repetition of the noise is similar to the last and the predictability of the noise allows creation of an accurate antinoise signal.

Practical application of this approach still had to wait as the electronic technology available at that time was not sufficient for implementation of active noise cancellation systems. Now digital computer technology has evolved to the point where cost-effective digital signal processing (DSP) microcomputers can perform the complex calculations involved in noise cancellation. This advance has made it feasible to apply active noise cancellation at reasonable cost to previously difficult problems in low-frequency automotive noise and vibration.

---

### 31.1 NOISE SOURCES

---

Sources of noise and vibration exist throughout an automobile. One type of noise is due to turbulence and is, therefore, totally random and impossible to predict. This makes it a difficult noise to cancel unless the source of the noise is well understood.

Engineers like to look at signals, noise included, in the frequency domain. That is, “How is the noise energy distributed as a function of frequency?” These turbulent noises tend to distribute their energy evenly across the frequency spectrum and are, therefore, referred to as broadband noise. Examples of broadband noise in cars are wind and most road noise. A typical broadband noise spectrum is shown in Fig. 31.1.

A large number of noises are different. These narrowband noises concentrate most of their noise energy at specific frequencies. When the source of the noise is a rotating or repetitive machine such as an automobile engine, the noise frequencies are all multiples of a basic noise

31.1

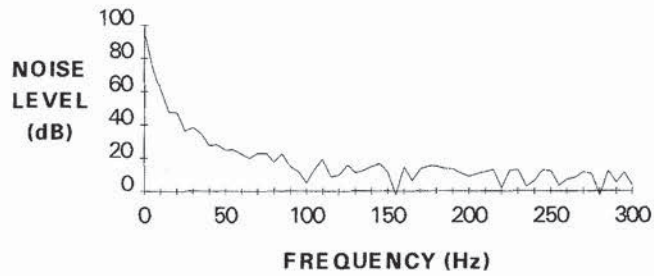

FIGURE 31.1 A typical broadband noise spectrum.

cycle and the noise is approximately periodic. The repetition rate of the noise cycle of a four-stroke automobile engine is two full revolutions (all cylinders firing). A typical narrowband noise spectrum is shown in Fig. 31.2.

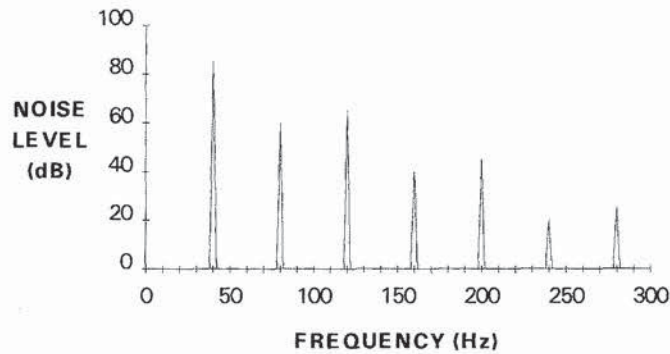

FIGURE 31.2 A typical narrowband noise spectrum.

Examples of sources of narrowband noise in automobiles include exhaust noise, along with broadband noise due to turbulence generated in the muffler; engine vibration, the major source of the “boom” in the passenger cabin; ventilation fans, again accompanied by broadband noise due to turbulent flow; and tire noise, with a regular tread pattern.

### 31.1.1 Noise Measurement

Any variation in air pressure is perceived by the human ear as sound. The pitch of the noise is related to the speed at which the pressure varies. As a reference, when the pressure fluctuates 440 times per second, the ear perceives it as the musical note “A” above middle “C.” The intensity of the noise can be stated either in terms of the peak sound pressure level (SPL) or in terms of the noise power that varies proportionally with the square of the SPL.

Noise is usually measured in decibels and is defined as:

$$\text{Noise}_{\text{dB}} = 20 \cdot \log_{10}[\text{SPL}/\text{SPL}_{\text{ref}}]$$

or equivalently,

$$\text{Noise}_{\text{dB}} = 10 \cdot \log_{10}[(\text{noise power})/(\text{noise power}_{\text{ref}})]$$

where the reference (0 dB) is set as the softest 3-kHz tone that an average human can hear in a perfectly quiet environment.

An overall measure, commonly used in specifications, is A-weighted noise (dBA). It is adjusted to compensate for the fact that the average human ear has lower sensitivity at low and high frequencies at normal listening levels.

### 31.1.2 Passive Noise Control

The first line of defense against noise is good design. All machines should be well balanced. Symmetry in design and careful manufacturing can significantly reduce vibration and noise. Turbulence can be reduced by good aerodynamics. High “Q” resonances in structures and gas flows should be avoided.

The second line of defense is to absorb noise and vibration energy and control its propagation using passive materials. The use of sound-absorbing and rigid materials to reduce noise levels is an effective approach at high frequencies. Below 500 Hz, however, the cost, weight, and inefficiencies due to passive sound attenuation often make this approach ineffective or impractical. Another technique for noise control is required.

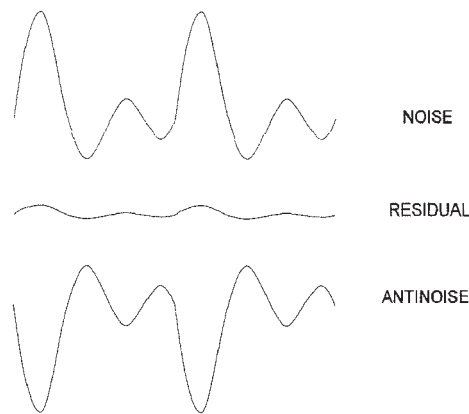

**FIGURE 31.3** Relationships in time among noise, antinoise, and residual noise.

### 31.1.3 Noise Cancellation Technologies

**Antinoise.** The idea to create a copy of the noise and use it as antinoise to cancel the original dates back to the early part of this century. Figure 31.3 shows the relationship, in time, of a noise signal, an antinoise signal, and the residual noise that results when they meet. Note that active noise cancellation does not mask the noise; it removes a significant portion of the noise energy from the environment.

**Digital Feed Forward.** Digital feed forward is shown in Fig. 31.4 as used to reduce the noise in an air duct. This is the classic example application for active noise cancellation and is widely discussed in the technical literature. It is also the method to use to control blower noise in automotive ventilation systems and is discussed further in the applications section later in this chapter.

Referring to Fig. 31.4, a microphone is placed upstream in the duct to get a reference sample of the noise. The effect of the duct on the noise is modeled to produce an antinoise waveform at the output speaker. A residual microphone is placed downstream in the duct to determine how well the system is operating and the duct model is continuously adjusted to maintain peak cancellation. Feedback compensation is also required since the antinoise waveform also propagates backwards along the duct and makes the reference signal inaccurate. Incorrect feedback compensation results in unstable operation.

Systems that cancel broadband noise require causality (the reference signal must give a sufficiently advanced indication of the approaching noise). Noise that correlates with the reference will be canceled. Digital feed forward systems can readily achieve 6 to 10 dB (50 to 70% reduction in sound pressure level) in practical use.

Most active noise cancellation systems employ a variant of the LMS algorithm known as Filtered-X. The basic LMS algorithm correlates an error signal (the residual noise in this case)

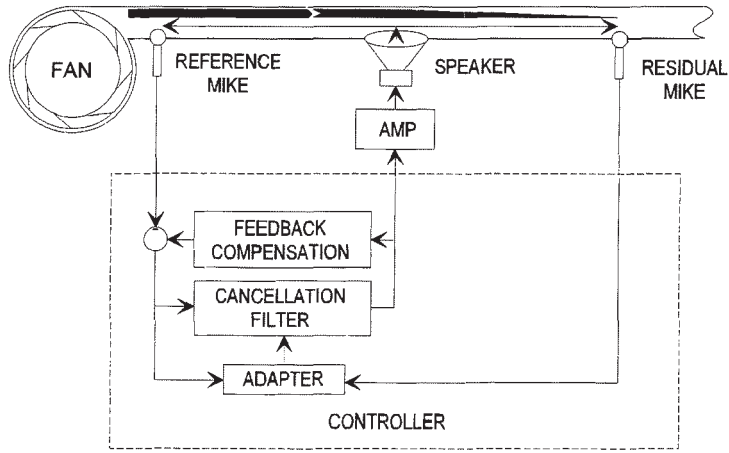

FIGURE 31.4 Feed forward cancellation system.

with a reference signal (called “X” by Widrow and Stearns, *Adaptive Signal Processing*, Prentice-Hall, 1985). The result is then multiplied by an adaptation rate constant and used to adjust the relevant parameter of the adaptive filter. This is done repeatedly for each filter parameter with the objective being convergence to an operation that minimizes the average power in the error signal.

In real-world systems, the LMS algorithm does not converge due to the delay and gain effects of the physical path taken by the antinoise signal. Using a compensation filter on the reference signal (hence, the name Filtered-X), restores stability and produces a well-behaved system.

**Synchronous Feedback.** The technique known as synchronous feedback, developed by G. B. B. Chaplin in the mid-1970s, is very effective on repetitive noise and does not rely on causality. Here, instead of the reference microphone, a tachometer signal is used to provide information on the rate of the noise. Since all of the repetitive noise energy is at harmonics (or multiples) of the machine’s basic rotational rate, the DSP micrometer can dedicate its resources to canceling these known noise frequencies.

Figure 31.5 shows the configuration of such a system applied to reduce engine exhaust noise. Its basic operation is described in the applications context in the next section.

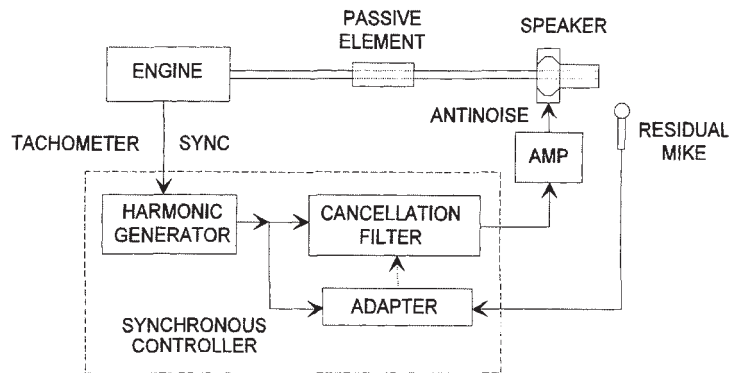

FIGURE 31.5 Narrowband noise cancellation (an active muffler).

## 31.2 APPLICATIONS

### 31.2.1 Canceling Exhaust Noise

**The Passive Muffler.** Passive mufflers are now used to control exhaust noise in automobiles. There are three classes of these mufflers.

**Absorptive Mufflers.** These are the straight-through or “glass pack” mufflers that were used in the hot rods of the 50s. They consist of a length of pipe with holes wrapped by fiberglass (or other sound-absorbent material) which is then enclosed by a larger diameter pipe. Absorptive mufflers are very effective at high frequencies, reduce turbulence in the exhaust, and produce little or no back pressure. They have little effect, however, on the low-frequency tonal noise from the engine unless the muffler is made impractically large.

**Dispersive Mufflers.** These mufflers work by creating a tortuous path for the exhaust, dissipating some noise energy while spreading the remaining noise energy across frequencies through turbulent flow. A significant amount of exhaust gas pressure is created in this process. The backpressure decreases engine efficiency. Gas mileage is reduced (typically 5 percent in city driving and 1 percent in highway driving) and peak horsepower is wasted (up to 10 percent) pushing the exhaust gasses against the back pressure. Dispersive mufflers can be effective in noise reduction at low frequencies at a reasonable size but only at the cost of high backpressure. They can have less backpressure, but then can be impractically large and heavy.

**Reactive Mufflers.** Reactive mufflers use acoustical resonances to reflect noise energy back to the source. This technique is often used to handle a strong noise at a particular frequency. It is a good technique for fixed rpm engine noise, but does not deal effectively in automobiles where engine rpm (or temperature, since the speed of sound, nominally 1100 ft/s, changes with temperature) varies. Reactive mufflers do introduce some backpressure but much less than dispersive mufflers.

The passive mufflers found in today’s automobiles use a combination of dispersive and reactive techniques.

**An Active Muffler System.** Figure 31.5 shows an active muffler system as it would be applied to an automotive engine exhaust. The passive element is a simple straight-through glass pack muffler (absorptive) that controls noise above 500 Hz. The active muffler is a speaker cabinet that is concentric to the exhaust pipe and outputs the antinoise in a ring around the end of the exhaust. The symmetry of the noise and antinoise sources in this arrangement provides for global cancellation of the low-frequency noise (at very low frequencies, a side-by-side arrangement can also work). A microphone in the exhaust sound field feeds back the residual noise (after cancellation) so that the adapter (usually an LMS adaption algorithm) can continuously adjust the cancellation to drive the residual noise toward zero at the noise frequencies. The tachometer signal drives a harmonic generator to internally provide pure tones at the harmonics of the engine’s basic cycle (two full revolutions in a four-cycle engine). This sets up the whole system to concentrate its efforts on the noise from the engine.

The cancellation algorithm is executed in a modern DSP computer that fits on one 250-cm<sup>2</sup> printed circuit board. Included on this board are:

- A digital signal processing computer (such as the ADSP-2101 from Analog Devices) capable of 10 million operations per second
- Two low-pass filters set at 500 Hz to avoid aliasing (the confusion of high-frequency signals with low-frequency signals due to sampling)
- An A/D converter to measure the noise remaining after cancellation
- A D/A converter to output the antinoise

The electronic equipment also includes an audio power amplifier (100 W for a typical automobile exhaust system) to generate the required antinoise power. Since the antinoise is at low



frequencies, a Class D switching amplifier should be used to further enhance energy efficiency. The total electronics package for a single-channel control system should be under \$100 when produced in volume.

**System Performance.** Active muffler systems can significantly attenuate exhaust noise. In steady state driving conditions, strong tonal components can be reduced by more than 25 dB with only a slight decrease in the attenuation level during rapid changes in driving conditions, such as gear shifting or sudden acceleration. The sound quality can also be managed by adjusting the attenuation level as a function of frequency, harmonic number, or engine conditions.

**Current Status.** Active muffler systems for cars, busses, and trucks are currently under development by several companies. They have been demonstrated on production cars and passed life tests. Larger systems have been tested on trucks and busses and field trials were underway in 1993 on several metropolitan bus fleets in the United States and Canada. This is a viable technology that is going to be used in production vehicles in the middle of this decade due to the effective performance and fuel economy enhancements it provides in automotive designs.

### 31.2.2 Controlling Engine Vibration

**Passive Vibration Control.** A primary consideration in modern automobile design is fuel economy. Automobile engines are therefore smaller and have fewer cylinders than the engines of a few years ago. Limiting this trend is the desire for a smooth-running car. It is difficult to balance the vibrational forces in an engine—especially the component at twice the engine rotational rate—with a small number of cylinders. One option is to use counter rotating shafts inside the engine that have a slight imbalance and spin at twice the engine rpm. The forces generated by the extra shaft can be designed to cancel the undesired vibration. The drawback to this approach is that it uses a significant percentage of the engine power (up to 10 percent has been estimated) by adding weight and friction losses.

Given that the engine vibrates, much design effort has gone into rubber engine mounts. Making the mount soft prevents engine vibration from propagating through the supporting members into the passenger compartment. The problem with soft mounts is that the engine is the heaviest single component in the car. If the engine is not firmly mounted, the handling characteristics of the automobile will suffer. The automotive designer is therefore left with a compromise among performance, economy, and comfort.

**Active Engine Mounts.** A solution to the vibration problem is to provide an active mount that is compliant or soft only at the vibration frequencies. Here an active vibration control system dynamically adjusts the dimensions of each engine mount so that engine vibrations are isolated from the car chassis. Again, the energy needed by the electronics is much smaller than the energy that would be lost using the passive solution. A more energy-efficient car is the result.

Figure 31.6 shows synchronous cancellation applied to create an active engine isolation mount. The antivibration continuously works against the stiffness of the mount to keep the mount out of the way of the engine at harmonics of the vibration cycle. No vibration forces are then passed through the mount from the engine and the supporting frame is vibration free.

**System Performance.** An active mount system can reduce peak vibrational components up to 25 dB. When applied to the major engine-mounting sites, active mounts significantly reduce vibration in the passenger compartment. They can also reduce secondary acoustical noise generated by vibrating surfaces in the passenger compartment—the major source of boom noise in cars.



small number of speakers. If a set of residual microphones is placed around the volume to be silenced, spaced less than  $\frac{1}{4}$  wavelength apart, a multichannel noise cancellation control system can synthesize the required antinoise field. Figure 31.7 shows a general configuration and the resulting quiet zone.

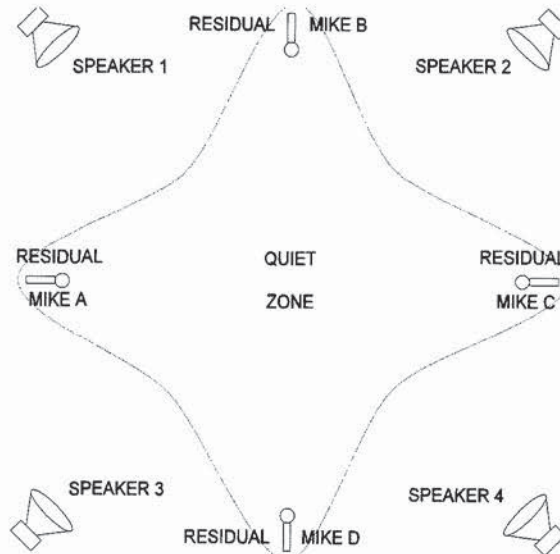

FIGURE 31.7 Zonal noise control for an automobile.

The algorithm is more complex than in single-channel applications since each residual microphone now “hears” antinoise from each of the antinoise speakers, and the electronic equipment is more expensive. This also occurs to a lesser extent for dual exhaust and multiple mount systems.

**System Description.** Figure 31.8 shows a zonal noise control system adapted for use as an automotive cabin-quieting system. The four to six residual microphones are placed near normal passenger head positions in the roof liners, seat backs, and/or door panels. Extra microphones are used, since at some frequencies resonances in the cabin will place a null of the sound at some locations.

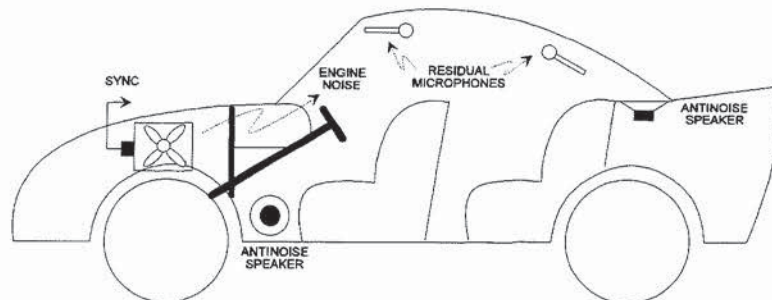

FIGURE 31.8 An automobile cabin-quieting system.



Four antinoise speakers are placed at convenient locations in the cabin. The existing sound system can be used to save money but care must then be taken to insure that the high-level antinoise tone does not create distortion in the amplifiers and speakers. This will usually require an upgrade in speaker quality, and separate low-frequency subwoofer speakers are desirable.

Proper design of a cabin-quieting system involves a careful analysis of cabin acoustics to determine proper speaker and microphone placement. It also depends on the existence of sufficient sound-absorbing materials in the cabin to limit the strength of resonances so that the mathematics of the algorithm do not require excessive precision.

**System Performance.** Cabin-quieting systems can reduce the peak boom by up to 10 dB. This significantly enhances any vehicle that has a major boom problem.

**Current Status.** Cabin-quieting systems have been installed and tested in a number of production cars. One model car with a cabin-quieting system was marketed in Japan in 1992. An aircraft manufacturer has announced the intention to market similar, but significantly larger, systems in its 1994 model turboprop aircraft. This is a currently viable technology to enhance automotive designs.

### 31.2.4 Controlling Blower Noise

Most of the noise from the heating/ventilation/air conditioning (HVAC) blower in cars is due to turbulent flow in the distribution ducts. This noise can be reduced through careful design of the ducts. Some guidelines follow:

- Reduced air velocity is the strongest factor in controlling turbulence. Larger duct cross sections and larger output ports should be used wherever possible.
- Duct liners made of sound-absorbing material can attenuate the higher-frequency noise.
- Discontinuities in the air flow should be eliminated. All turns should be smooth as any change in air flow direction or obstructions will generate additional turbulence and noise.

Passive controls can give 6 to 10 dB of improvement in the noise level and the successful use of active noise control for further reduction requires that attention be paid to passive controls first.

**An Active Duct Silencer.** The feed forward cancellation system in Fig. 31.4 has already been described in the context of controlling broadband noise in an air duct. Implementation of a duct cancellation system requires a close interaction with the physical design of the air distribution system in the car. A successful system will result only after several design iterations between the group doing the cancellation system and the design group responsible for the cabin design.

A good duct cancellation system in these small ducts can reduce the noise by 10 to 15 dB from 50 Hz to 1 kHz. This results in a typical noise reduction in the dBA noise measurement of 4 to 6 dB.

Duct cancellation systems for commercial applications have been available for several years. The cost-effective (less than \$50 system cost) application of this technology to home appliances has been announced and will see production in 1994. This is another viable application of active noise control in current automobile designs.

### 31.2.5 Active Suspension Systems

The technology used in an active suspension system is closely related to that used in active noise cancellation. For a description of active suspensions, see Chap. 17.



**GLOSSARY**

---

**Active mount** The use of an actuator in a mounting system to continuously deform the mount so that no vibrational forces are passed through the mount at specific frequencies.

**Adaptive filters** A signal-processing technique (usually digital) in which filter parameters are continuously modified to optimize some aspect of system performance.

**Antinoise** sound that is identical to, but exactly opposite to, a disturbing sound. If heard alone, it would sound identical to the original noise, but it cancels the offending sound, thereby reducing the noise level.

**Causality** In the real world you cannot have a result that precedes a cause. In an antinoise system that deals with broadband noise, the reference signal must be derived from a position in the system where noise that is correlated to the observed noise exists earlier in time.

**Harmonic number** Narrowband sound, such as musical notes or noise from rotating machines, consists of a number of components at frequencies that are multiples of a fundamental frequency. The harmonic number is the ratio between the frequency of a particular component and the fundamental frequency.

**LMS** The least mean squares measure of the error in a system.

**Noise cycle** The repetitive cycle of a noise source. It is two revolutions in a four-stroke engine.

**Residual noise** The noise that remains after the antinoise meets the noise.

**Resonance** A phenomenon that occurs in low-loss systems where reflections reinforce the original energy. Energy storage in resonant structures can make noise problems much worse.

**Sound field** The distribution of sound energy in a defined space. It can be quite complex when resonances are present.

**SPL** The sound pressure level is the peak variation in air pressure due to a sound.

**Subwoofer** A speaker that is designed to only produce sound below 200 Hz. A crossover filter is used to pass low-frequency energy to the subwoofer and all higher-frequency energy to other speakers.

**Tonal noise** Noise that is made up of pure sinusoidal components with frequencies that are all multiples of a fundamental frequency.

**Turbulence** The random mixing in an air flow that causes noise. A perfectly smooth flow is called laminar.

**BIBLIOGRAPHY**

---

- Air Movement and Control Association, Inc., *Fans and Systems*, ACMA Publication 201-90, 1990.
- Chaplin, G. B. B., "Anti-noise—the Essex breakthrough," *Chartered Mechanical Engineering*, vol. 30, 1983, pp. 41–47.
- Denenberg, J., "Anti-noise," *IEEE Potentials*, vol. 11, no. 2, April 1992, pp. 36–40.
- Eghtesadi, Kh., and H. G. Leventhal, "Comparison of active attenuators of noise in ducts," *Acoustics Letters*, vol. 4, no. 10, 1981, pp. 204–209.
- Eghtesadi, Kh., and J. W. Gardner, "Experimental results of the nonrestrictive electronic muffler on internal combustion engines," *Acoustics Letters*, vol. 4, no. 4, 1990, pp. 70–73.

- Eghthesadi, Kh., M. McLoughlin, and E. W. Ziegler, "Development of the simulation model of the multiple interacting sensors and actuators (MISACT) for an active control system," *Recent Advances in Active Control of Sound and Vibration*, C. A. Rogers and C. R. Fuller (eds.), Virginia Polytechnic Institute, April 15-17, 1991, pp. 246-257.
- Lemme, H., and J. Denenberg, "Larm Kontra Larm," *Elektronik Magazine*, vol. 41, no. 19, Sept. 1992, pp. 42-48.
- Mendat, D., et al, "Active control of centrifugal fan noise," *Fan Noise—An International INCE Symposium*, CETIM Senlis, France, Sept. 1-3, 1992, pp. 455-462.
- Nelson, P. A., "Causal constraints in the active control of sound," *IEEE Conference on Acoustic Speech and Signal Processing*, vol. 1, April 1987.
- Nelson, P., and S. Eliot, *Active Control of Sound*, Academic Press, 1992.
- "Reducing the annoyance of noise," *Proceedings of NOISE-CON 90*, University of Texas at Austin, Oct. 1990.
- Ross, C., "Quieter air travel takes off with active noise control technology," *Noise and Vibration Worldwide*, 1993.
- Ross, Colin, "The control of noise inside passenger vehicles," *Recent Advances in Active Control of Sound and Vibration*, C. A. Rogers and C. R. Fuller (eds.), Virginia Polytechnic Institute, April 15-17, 1991, pp. 671-681.
- Warneka, G. E., "Active attenuation of noise—the state of the art," *Noise Control Engineering Journal*, **18** (3), 1982, pp. 100-110.
- Widrow, P., and S. D. Stearns, *Adaptive Signal Processing*, Prentice-Hall, 1985.

### ABOUT THE AUTHOR

Jeffrey N. Denenberg has over 20 years of experience in the electronics, communications, and computer industries. He worked for Motorola, Bell Laboratories, and ITT prior to joining Noise Cancellation Technologies as vice president of engineering and chief technology officer. He holds 11 patents and is a Senior Member of the IEEE.



---

# CHAPTER 32

---

## FUTURE VEHICLE ELECTRONICS

---

**Randy Frank and Salim Momin**  
*Motorola Semiconductor Products*

---

### 32.1 RETROSPECTIVE

---

Both the content and complexity of semiconductor technology for computing, power control sensing, communications, signal conditioning, and transient suppression is destined to increase in future vehicles. Therefore, this final chapter will tackle the difficult subjects of identifying potential technology developments and trends for future systems and consolidating previously mentioned development activities in areas relative to vehicle electronics. The terminology of the future generations of electronics (refer to the glossary at the end of this chapter) is a strong indication of how different emphasis will be placed in future vehicles.

Semiconductor technology is being applied to sensors in several automotive applications. Semiconductor technology is also at the heart of digital electronics including MCU (microcontroller unit), MPU (microprocessor unit), and DSP (digital signal processing) technology. Outputs of several systems have been controlled by power MOSFETs, smart power, and even IGBT (insulated gate bipolar technology) power devices. Communications, not only to the vehicle but from the vehicle, will cause major changes which will require high-frequency semiconductors. However, high-level digital electronics in MCU, MPU, and DSP will continue to determine the future of automotive electronics. Their growth from two MCUs per vehicle in 1980 to 14 per vehicle in 1990 and expected use of 35 per vehicle by 2000 will dominate automotive electronics content no matter which vehicle subsystem is involved.

---

### 32.2 IC TECHNOLOGY

---

Since the advent of integrated circuit (IC) technology, the automotive engineer has been designing more and more complex electronic modules—partially to meet government-mandated regulations for pollution control and fuel economy but also to provide increased performance and creature comforts. Table 32.1 is a summary of the control systems and subsystems being used or developed for modern vehicles. Transitions to higher levels of complexities are already underway as car companies worldwide migrate their engine management ECUs from 8-/16-bit microcontrollers to 32-/64-bit CISC/RISC based processors with more than one execution engine on-chip, such as Motorola's MC68332.

32.1



**TABLE 32.1** Pervasiveness of Electronics in Modern Control Systems

Safety & chassis	Powertrain	Entertainment	Driver information	Convenience & body control
Traction control	Dynamic engine mount	Noise reduction systems	Digital & analog gauges	Multiplexed wiring
Antilock brakes	Electronic camshaft	Cellular radio/telephone	Engine diagnostic display	Intermodule network
Load-sense braking	Ignition timing	CD & optical disc players	Service reminders	Body system diagnostics
Air bag restraints	Spark distribution	CB radio	Digital clock	Smart power drivers
Dynamic ride control	Fuel delivery control	Digital audio tape	Trip computers	Antitheft device
Active suspension	Turbo control		Navigational computers	Climate control
Load leveling	Emissions monitor		Intelligent highways	Keyless entry
Electronic steering	Voltage regulator		Collision avoidance	Light reminder
	Alternator		Drowse/DWI alert	Memory seat
	Transmission shift			Sensory wipers
	On-board diagnostics			Auto door lock
	Operational adaptation			Headlight dimming
	Energy recovery			Window control
	Electronic muffler			
	Cruise control			

DSP technology is being used in audio and suspension control algorithms with new applications such as noise cancellation just on the horizon. Semiconductor technology, and specifically the integrated circuit, is the enabling technology. Thus, before we can discuss the future of automotive electronics, the future developments in semiconductor technology along with its critical success factors must be understood since they will have a profound impact not only on what systems get designed but, more importantly, on how they get designed.

The 1992 SIA Semiconductor Technology Workshop established a 15-year roadmap for key IC device characteristics such as feature size, chip size, defect density, power dissipation, and number of I/Os (Table 32.2). Based on this roadmap, the design engineers at the turn of the century will be dealing with ICs which will integrate 50 to 100 million transistors on a chip with clock speeds in excess of 250 MHz. This is based solely on extrapolation of today's technologies and does not take into account dramatic breakthroughs in technologies such as *quantum effect transistors*, which could increase device complexities by several orders of magnitude. There is already some work being done at the Massachusetts Institute of Technology and Texas Instrument R&D laboratories on *3-D quantum ICs* with complexities of 20 billion transistors. Today's more complex circuits have three to four metal layers, but future circuits will have six to seven metal layers for interconnect and power routing by the year 2005. Three-dimensional interconnections are key to denser electronic circuits. Thin circuits that can be lifted off an underlying substrate may allow not only faster circuits, but combinations of otherwise too-complex processes to be achieved and circuit placement in more varied packaging shapes including remote displays, sensors, or actuators.

**TABLE 32.2** General Technology Roadmap

Characteristic	1992	1995	1998	2001	2004	2007
Feature size	0.5	0.35	0.25	0.18	0.12	0.1
Gates per chip	300K	800K	2M	5M	10M	20M
Wafer processing cost (\$/cm <sup>2</sup> )	\$4.00	\$3.90	\$3.80	\$3.70	\$3.60	\$3.50
Chip size (mm <sup>2</sup> )	250	400	600	800	1000	1250
Wafer diameter (mm)	200	200	200-400	200-400	200-400	200-400
Defect density (defects/cm <sup>2</sup> )	0.1	0.05	0.03	0.01	0.004	0.002
Number of interconnect levels	3	4-5	5	5-6	6	6-7
Power supply voltage (V)	5	3.3	2.2	2.2	1.5	1.5
No. of I/Os	500	750	1500	2000	3500	5000
Performance (MHz)	120	200	350	500	700	1000

Higher-speed electronics can generate high power levels, so design techniques to minimize the power or cope with the existing level of power dissipation are being pursued. Novel cooling methods using heat pipes enable self-contained cooling capability. Higher-temperature operating materials such as gallium arsenide (GaAs), silicon carbide (SiC), and diamond are also being investigated by automotive electronics manufacturers to solve the heat problem. The most critical technology required to turn the semiconductor technology roadmap into reality is CAD—computer-aided design.

### 32.2.1 Design Methodology/CAD

Design is the activity that turns underlying technologies into product solutions that satisfy society's needs. Design, coupled with a testing discipline to ensure quality, is the vehicle that generates revenues for the industries. Today, design activity is based on a loosely coupled, ad hoc collection of tools and techniques. The most successful companies use highly refined design methodologies that are dependent on vendor-supplied point tools and are heavily augmented by proprietary tools that encapsulate each company's accumulated design expertise. Use of these tools outside the company's design groups is next to impossible. Over the next 5 to 10 years the complexity of chips will grow so dramatically that new tools and techniques for IC design will be required. Coupled with continuing pressures on reduced product development cycle time, error-free designs, and affordable test procedures, these CAD tools for IC design will have to extend well into the systems development environment. Electronic design automation (EDA) will not only be a necessity but it will also be the only way of handling the prevailing levels of device and system complexities. Without the advanced level of technology tools, expected performance and reliability levels will not occur.

### 32.2.2 CPU Architecture

MPUs and MCUs in vehicle control systems have been developed around complex instruction set computer (CISC) architectures. The availability of larger, faster memory technologies allows RISC architecture with simpler instructions to achieve higher throughput and faster cycle times. RISC design philosophy includes:

1. Fixed length, consistently encoded instructions
2. A register-to-register (load/store) architecture with primitive addressing modes
3. Relatively simple instructions
4. A large orthogonal register file
5. Three-operand (nondestructive) instruction format

MPU chips are available in 1994 with floating-point performance of SPECfp92\* of 85 at 80 MHz. Over 1.6 million transistors are integrated in a chip that is only 85 mm<sup>2</sup>. This performance level is considerably above the highest-performing CISC architecture and utilizes less silicon area.

The core processor has increased from 8 to 16-bits and now 32-bits to handle the number of calculations that are required in complex engine control systems. The 32-bit CPUs can deliver at least 50 times higher processing capability than the 8-bit designs. ABS systems are increasingly using 16-bit machines to reduce the time required to compute wheel speed inputs from analog sensors and activate the appropriate brake solenoids. Air bags have increased from simple to more powerful 8-bit MCUs when the air bag system uses electronic sensors.

Single-chip programmable digital signal processor (DSP) technology is used when mathematically intense algorithms, real-time operation, and high-speed data sampling are required in the control system. DSP units have been designed into sophisticated audio entertainment,

dynamic ride control, and noise cancellation systems. DSP units incorporate Harvard architecture similar to many MCUs and MPUs; extensive pipelining; dedicated hardware multiplier; special instructions not typically found in MCUs, such as multiply and accumulate (MAC); and fast instruction cycle times, less than 50 ns. DSP design can also be integrated into MCUs to provide similar functionality for systems.

It is important to note that automotive electronics manufacturers will benefit from higher levels of technology, but use of high-level electronics in the auto industry lags behind other segments, partially due to the design-in time and partially due to the cost. Only the level of performance necessary to solve the control problems that are expected to be encountered during the design life of the electronics is implemented. Figure 32.1 shows a general technology roadmap for one semiconductor manufacturer (Motorola) that provides detail for some of the elements of future semiconductors. The products that drive future technology are high-end microprocessors and fast static RAMs (SRAMs). However, other products, including logic, mixed-signal (analog/digital), sensors, and power devices, benefit from the improved process techniques and the tools that are developed to provide them.

## GENERAL TECHNOLOGY ROADMAP

### ULSI - HIGH PERFORMANCE LOGIC

	1990	1991	1992	1993	1994	1995	1996	1997	1998	1999	2000
<b>SRAM</b>	1Mb SRAM		4Mb SRAM		16Mb SRAM		64Mb SRAM				
<b>Devices/MPU</b>	1.5-2.5M	2-4M	3-5M	4-8M	5-11M	20-100M	20M - 500M				
<b>Die Size</b>	1.25 X 1.75cm		1.5 X 2.0cm		2.0 X 2.75cm						
<b>Technology</b>	HCMOS			HMOS/BiCMOS			BiCMOS				
<b>Voltage</b>	5V		5/3.3V		3.3V/2.5V			2.5V/1.5V			
<b>Min. Feature</b>	0.80µm	0.65µm	0.50µm	0.40µm		0.30µm	0.25µm		0.15µm		
<b>Litho Tool</b>	G-Line		I-Line		I-Line & Phase Shift Mask/DUV			X-Ray			
<b>Materials</b>	EPI/BL			EPI/BL/TRENCH			SOI				
<b>Gate Oxide</b>	150A		105A		80A			60A			
<b>CMOS</b>	N+POLY/LDD		N+/P+POLY With Silicide/LDD			Selective Silicon Elevated Source Drain					
<b>Bipolar</b>	Non-Self Aligned			Self Aligned			SiGe With Trench Isolation				
<b>Contacts</b>	Tapered			Straight-Walled, Filled							
<b>Metallurgy</b>	AL Alloy		AL Alloy M1,2,3,4				Copper				
<b>Metal Layers</b>	DLM	3LM		4LM			5-6 Level				

<b>PRODUCTS</b>	1Meg SRAM 68040/68050 88110/88410 683XX MCU	4 Meg SRAM 68060/68LP040 88120, PowerPC™ 683XXMCU	16 Meg SRAM 88130 RISC MCU PowerPC™	64 Meg SRAM Multi-Processors Large Cache
-----------------	--	--	--	--

FIGURE 32.1 Operating frequencies/feature size/integration level.

### 32.2.3 Memory

As part of reduced vehicle development time, electronics module manufacturers need semiconductor suppliers to turn ROM circuits in shorter and shorter design time. Also, new memory types, such as flash memory, are required to allow manufacturers to reprogram when the memory is installed in the module and still be reliable under all vehicle operating modes for the remaining life of the vehicle. Future developments include the ability to reprogram at lower voltages: 5 V and even 3 V.

Figure 32.2 shows the increase in memory, throughput, functions, and inputs and outputs (I/O) since model year 1980 and an estimate for model year 2000. The most dramatic increase has occurred in the memory (RAM). Program memory (ROM) is also increasing. Memory in future MPUs will be limited more by the programmer's ability to generate the code than by the hardware's ability to store or process it—unless fundamental changes occur to the process of code generation.

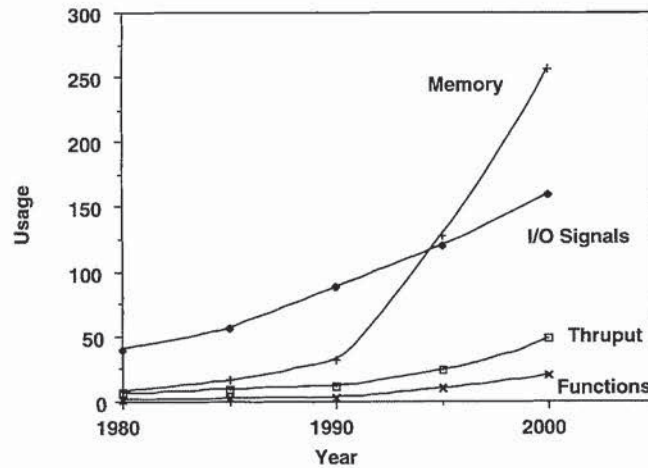

FIGURE 32.2 Automotive usage of microcontroller technology.

### 32.3 OTHER SEMICONDUCTOR TECHNOLOGIES

Semiconductor technology is also being applied to both the input and output side of the digital control to improve the performance of sensors and provide more efficient power switches. Both sensing and power devices are the focus of increased integration. The extent of integration depends on system constraints in the automobile in addition to the technology that is developed by semiconductor manufacturers. This section will discuss key items affecting future levels of system and component integration.

#### 32.3.1 Micromachining and Microelectronics

Semiconductor technology is also being applied to manufacture mechanical structures in silicon that provide more reliability, higher accuracy, and higher functionality, while also lowering the cost of sensing for the automobile. Continued use of these techniques for more complex structures and combined sensors (e.g., pressure and temperature) will increase as university, government, and industry R&D technology is adapted by sensor and semiconductor manufacturers. Sensor technology has been identified as one of the key factors required to maintain leadership in automotive electronics.

Increased electronics will be used with these sensors either by simultaneously fabricating electronic circuitry with the mechanical structure or by packaging techniques such as multi-chip modules. Figure 32.3 shows a sensor technology migration path that ultimately has the sensor(s) fabricated directly on CMOS MCUs. While the cost of this final form may be several years away from the level necessary for automotive use, the technology capability can be demonstrated today. Intermediate forms of integration with CMOS memory components used for calibration and localized digital logic providing decisions are extremely likely within the near future (before 2000). The electronics system design will change as inherently digital signals, instead of analog, can be input directly to the MCU. These signals could be at the level that allows usage by several vehicle systems using a multiplex (MUX) bus. However, standards, such as SAE J1850, will be necessary to make the digital output transducers as readily available from many sources like today's analog output sensors.



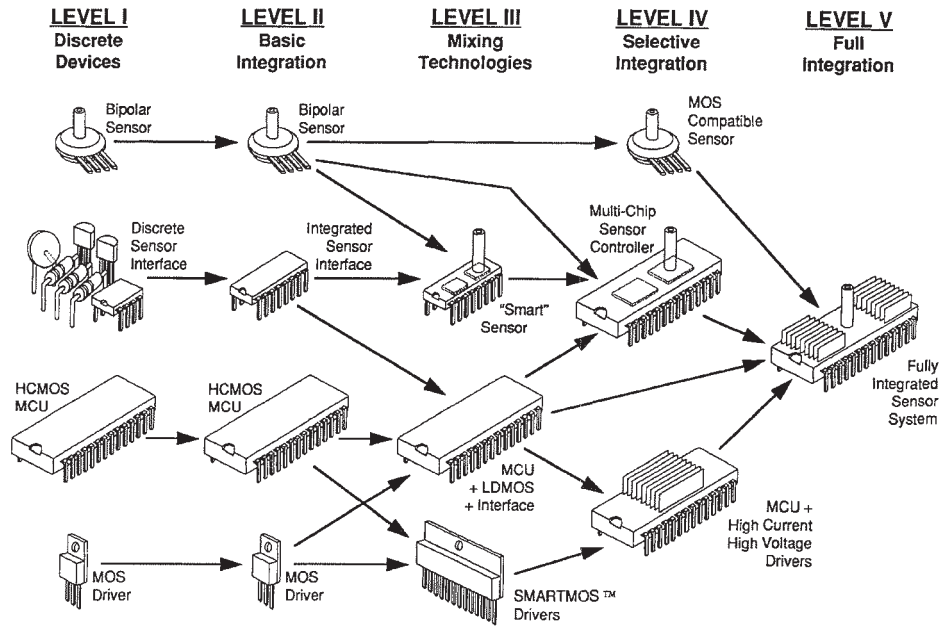

FIGURE 32.3 Sensor technology migration path.

### 32.3.2 Voltage Capability

In order to achieve high density in integrated circuits, the maximum voltage is being reduced from 5 to 3 V in computer and portable products. This level will be reduced even further as higher levels of integration require smaller and smaller geometries, and portable products are designed to operate at even lower voltage levels. Since this area is considerably larger than the automotive electronics area, it represents the mainstream of electronics technology. The automobile, however, operates from a 12-V battery today and is being pushed toward higher operating voltages to handle the ever-increasing loads that are part of every new vehicle system. Even the 12-V system has to deal with considerably higher voltage due to transients, including load dump. Electric vehicles will have a battery supply over 200 V. The requirement to withstand higher voltages reduces the efficiency of power semiconductors. Furthermore, the voltage extremes affect the choice of power devices and the level of integration that can be achieved. If the system voltage is increased to 24, 36, or 48 V, semiconductors will be among the system components that are significantly affected by the higher voltage.

### 32.3.3 Power Control

Depending on the vehicle, every 10 A of electric load reduces fuel economy by 0.3 to 0.5 miles per gallon. Design changes to cope with increased loads include:

- More energy-conserving designs
- Smarter power supplies that manage peak alternator-current demand
- Overvoltage transient protection from one central location, which is even more important if system voltage is increased
- Two 12-V batteries per system, especially on high-end vehicles

More efficient power devices are required to reduce overall vehicle power consumption and to reduce power dissipated in electronic modules. The on-resistance area product has been reduced nearly tenfold from the early 1980s to 1993, since the first use of power MOSFETs on vehicles. Further improvements are made by reducing all of the resistive elements of the MOSFET, including metal connections to the package, starting material and cell structure. Figure 32.4 shows how the specific on-resistance can be reduced by using high-cell-density power MOSFETs and lower voltage ratings. Ignition coil drivers are high-voltage (greater than 350 V) applications on internal combustion vehicles where insulated gate bipolar transistors are more efficient than power MOSFETs or bipolar power transistors.

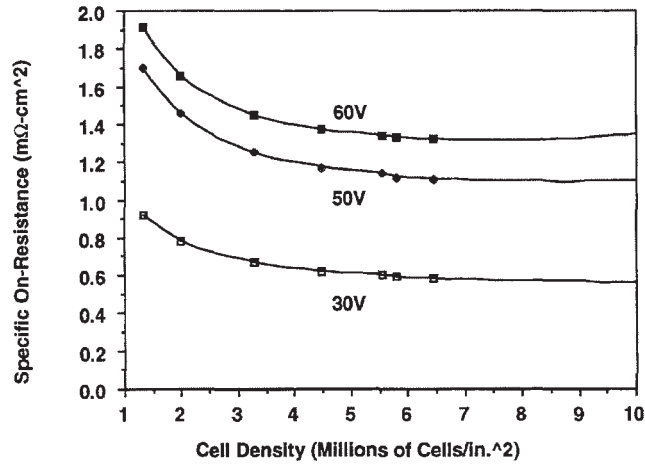

FIGURE 32.4 Power efficiency vs. voltage.

Merging power devices with control circuitry is also part of the integration that is occurring at an increasing rate as system complexity increases. Several design and processing techniques are used to merge these devices depending on the switch type and performance expectations. Table 32.3 provides some indication of differences in commonly used processes. Smart power, or power ICs are the terms that are generally used to describe these types of power devices.

The smart power approach to system design means that a number of circuit elements that would previously have been discrete components or the combination of a standard, or custom IC, and discrete output devices can be consolidated into one single device as illustrated in Fig. 32.5. This provides space saving, component reduction, total system cost reduction, improved performance, and increased reliability from the reduced number of interconnections. The choice of process technology has historically depended upon the type of control elements that were integrated. Some circuit elements, such as operational amplifiers (op amps), compara-

TABLE 32.3 Power ICs Attributes

Isolation process	Circuit components			Switch type		Complexity	Breakdown voltage
	Power MOSFET	CMOS	Bipolar	High side	Low side		
Self	Yes	Yes	No	Yes	No	Simple	Low
Junction	Yes	Yes	Yes	Yes	Yes	Medium	Medium
Dielectric	Yes	Yes	Yes	Yes	Yes	High	High

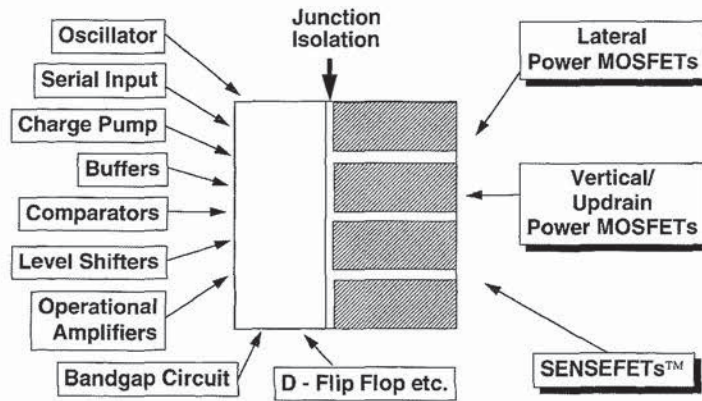

FIGURE 32.5 SMARTMOS™ technology cells.

tors, and regulators, are best implemented using a bipolar IC process. MOS circuitry handles logic, active filters (time delays), and current mirrors better than bipolar circuitry. Some circuits, such as A-D converters or power amplifiers, can be implemented equally well in either technology. A process that has both MOS and bipolar for the control circuitry does not have to sacrifice performance or features and, if it is combined with the appropriate output devices, it can handle the power control functions for a number of vehicle loads.

The need for increased diagnostics to meet legislated requirements, such as OBD-II, and to minimize time required to analyze vehicles experiencing faults is increasing the use and complexity of smart power devices. Power devices that can handle several amperes and operate at voltages in excess of 60 V have already been integrated into MCU processes. The number of loads that are controlled, the current and voltage rating of the output devices, and the power dissipation are factors that system designers must consider when evaluating the level of integration of power devices.

The three levels of power devices involved in automotive systems are power MOSFET, smart power IC with one or more power outputs, and MCU with integrated power devices. Integration in each of these levels and efficiency will improve in future systems. The ability to integrate memory components and transmit and receive digital signals at the power side of the control system is necessary in MUX systems. This also allows the system designer added flexibility in system partitioning.

#### 32.3.4 Semiconductor Operation at High Temperatures

Increased operating temperatures are driving development for new materials such as GaAs (gallium arsenide) and other III-V, wide band gap, semiconductor materials, SiC (silicon carbide), and diamond films. Other wafer-level assembly techniques that can provide more reliable operation at high temperature, such as wafer-to-wafer bonding and dielectric isolation, are part of today's semiconductor technologies that will be used in future vehicle electronics. As Chap. 5 pointed out, higher temperatures decrease reliability of electronic components. Therefore, improvements that allow higher temperature operation are being evaluated, and sometimes are a driving force for improving reliability. Some advanced materials, such as GaAs, also allow higher frequency operation or increased efficiency, providing additional incentive. The materials and techniques are being investigated for sensors, power, computing, and communication semiconductors. Their acceptance in one area could increase the effort to

design and qualify similar technologies in other areas. However, at present these approaches are more expensive and would only be used if they solved a problem that had no alternative solution.

**32.3.5 High-Frequency Semiconductors**

Increasing communication to and from the vehicle requires radio frequency (RF) transistors to receive and transmit signals and data. High-frequency operation is required for cellular communications and sensing in systems such as near obstacle detection. Several technology choices exist in the RF front end of a communication product that must operate at 900 MHz as Fig. 32.6 demonstrates. Silicon competes with GaAs in the 1- to 2-GHz range, but in the 2- to 18-GHz range, GaAs is the only solution. In 3-V, high-frequency (1-GHz) operation, GaAs has an efficiency of 50 percent versus silicon bipolar's 40 percent or LDMOS's 43 percent. Chipset approaches are frequently used in the early phases of system design and can be cost effective alternatives to higher levels of integration. High-frequency designs for radio frequency are considerably different than high-speed digital processes, which limits the integration of these subsystems. The frequency range is much higher in RF circuits, frequently 800 MHz and higher. Mixed-signal technology in these designs means not only digital and analog but also RF must be processed. Circuit isolation is required to prevent unwanted coupling of signals which can range from 3 V peak-to-peak to less than 1  $\mu$  V peak-to-peak. RFIC (radio frequency integrated circuits) technology or MMIC (monolithic microwave integrated circuit), and MESFETs are part of the communications semiconductors that will be used in future vehicles.

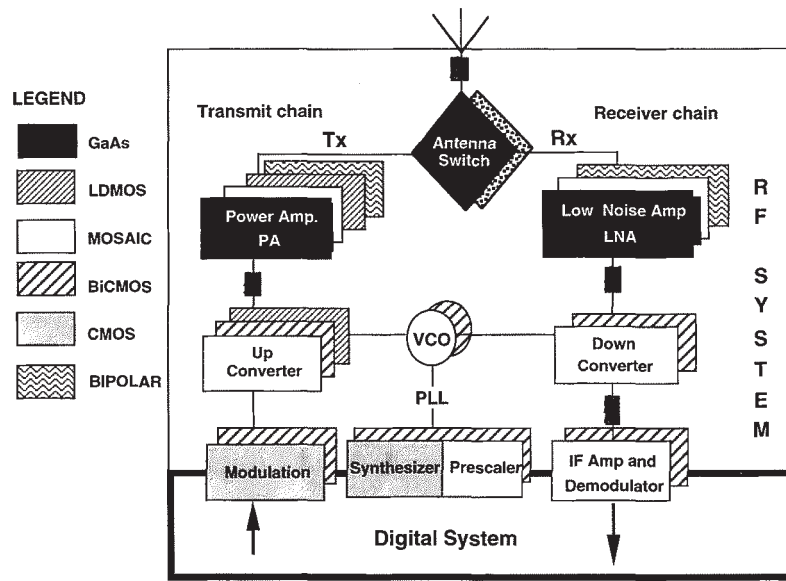

FIGURE 32.6 RF semiconductor technologies.

**32.3.6 Semiconductor Packaging**

Auto module manufacturers are using surface mount assembly techniques to improve reliability, reduce component size, and incorporate more functions in a given module form factor.



A number of SOIC packages are available for handling high-pin-count I/O in logic or high power in power ICs. Assembly techniques for surface-mount technology (SMT) also include flip chip, TAB (tape automated bonding), COB (chip on board), and bare die.

In many respects, the packaging requirements for highly integrated devices are similar to those for the full module. These include power distribution, signal distribution, heat dissipation, and circuit protection. In harsh applications, like the underhood mounting of automotive controls, hot and cold temperature extremes can result in severe damage to the electric connections in electronic components. Reducing the number of connections in a module, through the integration possible in a process like smart power ICs, reduces the number of potential failure points.

As more and more functionality is included in an IC design, the number of external components is reduced. This inherently lowers the number of solder joints that are required in a particular pc board layout. This can significantly reduce the potential for rejects in the surface-mount soldering operation. Unfortunately, in highly integrated silicon designs, packages are also required with power-dissipating capability and/or access to sense a mechanical input, such as a pressure port. These “combined” packaging problems have been solved at the module and not the semiconductor level. Smart power packaging engineers address the requirement for more complex I/O and higher power dissipation with increased lead count packages and integral heat-spreading capability. Sensor packaging engineers cope with increased media compatibility and higher pin count issues with new materials and unique attachment/access methods for pressure, acceleration, magnetic, or light sensing. Complex microcontrollers have high pin counts ( $\geq 256$  pins) with close spacing and high coplanarity requirements. Still other silicon processing technologies are required to provide system glue-chips that provide interfaces that are not cost-effectively integrated in a particular time frame. As a result, three or more packaging roadmaps are pursued.

To achieve increased functionality without increased silicon complexity, available silicon technologies are being combined at the package level in packages based on semiconductor, not module manufacturer, assembly techniques. These multichip modules (MCMs) are being evaluated for automotive applications. There has been a decline in the use of the previously popular DIP (dual in-line plastic) package. Other through-hole packages, such as SIP (single in-line plastic) and PGA (pin grid array), will also not increase. New SMT approaches, such as BGA (ball grid array) packages, are the focus of present packaging development. For future highly-integrated components, packaging techniques must take into account more complex, system-level requirements, as well as SMT assembly requirements.

Testing is also a major consideration as more and more functionality is combined into one package. In some instances, the ability to provide fully functional, fully tested silicon die is required for products that are provided in packaged form today.

### 32.3.7 System-Level Integration

Increased integration is occurring to achieve increasingly more cost-effective systems. However, integration necessary to have all system components, MCU+power+sensor(s), on the same chip, can lead to mask levels that are well beyond the level necessary to obtain reasonable yields. Those components that would significantly add to the cost or detract from the performance must be partitioned as a separate system component. Integration can minimize some unwanted components, such as parasitic capacitances or lead inductances, but it can also lead to unexpected interaction of other circuit elements. Proven building blocks or modules increase the confidence that a new silicon design will work properly the first time.

System-level chips based on structured design approach are just starting to appear. For example, Motorola’s CSIC, or Customer Specified Integrated Circuit, is a modular design approach that has over 150 developed combinations for solving a variety of 8-bit control problems. Figure 32.7 shows the concept of a System Chip™ integrated solution that combines input, output, and computation in a monolithic silicon chip. The MC68HC705V8 is an exam-

ple of today's level of system integration. It is a necessary first step towards the more complex systems of tomorrow. This chip has an on-chip voltage regulator, a complete single-wire multiplex interface message data link controller, and various memory functions. The voltage regulator provides a regulated 5 V ( $\pm 5$  percent) from battery voltages between 7 and 26.5 V and can withstand alternator transients up to 40 V. As noted in Sec. 32.2.2, required cost-effectiveness by automotive electronics also applies to levels of integration. In a given time frame, higher levels of integration may be possible, but not cost effective. The ability to shift portions of the system from one unit to another, and partition the system for the most cost-effective approach in the most timely manner, is the goal of auto electronics manufacturers and the force behind approaches like Motorola's Seamless Silicon System™ methodology. This technique will allow common design rules for various silicon components, including MCUs, smart power and sensors, that will facilitate integration paths like the one shown in Fig. 32.3. However, when separate devices are determined to be more cost effective, the decision to have them as separate components will be a simple choice of the designer.

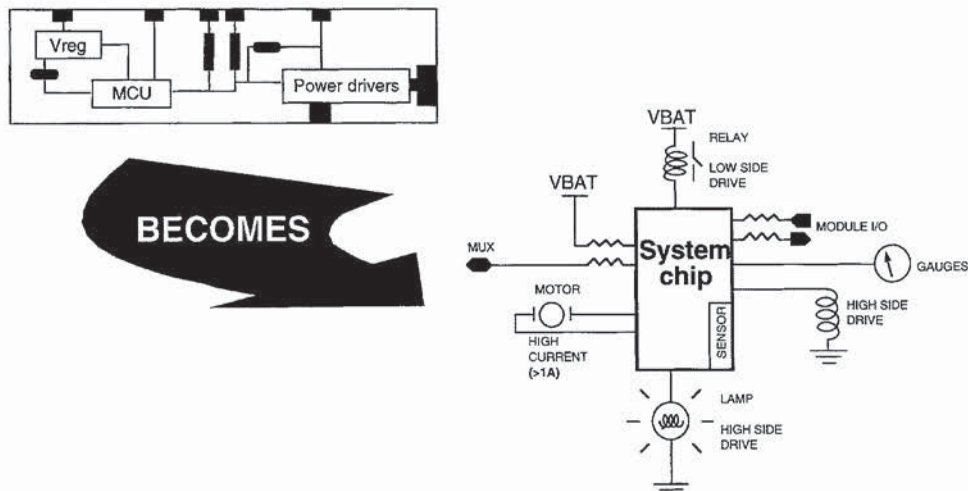

FIGURE 32.7 System Chip™ integrated solution.

### 32.4 ENABLING THE FUTURE

Driving forces for automotive manufacturers ultimately drive the electronic content of future vehicles. The major areas that impact electronics include meeting government regulations, environmental responsibility including recyclable materials, automotive manufacturing technology (and the transition from lean to agile manufacturing), improved security, increased safety to eliminate auto fatalities, reduced vehicle development time, high-efficiency 80-mpg super car, and the “personalized” car.

The first five items will be covered in more detail later in this section. The last three items on the list reflect key topics that are extremely timely and may not have appeared on a list developed in the 1980s.

United States manufacturers have gone on record with their goals of developing new vehicles in less time. In the mid-90s these goals are three years or less instead of the historical five years. Japanese manufacturers are already at the three-year design level and Chrysler has demonstrated the ability to design new vehicles in as little as 18 months. This will result in even shorter design cycles in the future. As a result, the more complex electronics that will be



part of these systems must be designed and verified in even less time than in the early 90s. This will require even closer linkage between semiconductor suppliers and automotive electronics manufacturers not only in hardware but also in the tools and software area as well.

The goal of a high-efficiency super car that can achieve 80 mpg is among the changes that can suddenly shape the direction of future electronics. While continuously more fuel-efficient vehicles have been developed over the past 20 years, government support for a reach-out goal can reduce the R&D time for enabling technologies.

Personalization in an increasingly nonpersonal world is among the marketing strategies that can impact electronics. The memory and automatic adjustments that are possible with electronics are already used to preset seat position and favorite radio stations when the automatic door opener identifies the driver of a multiple-driver vehicle. Electronics is also an essential part of the features used to differentiate vehicles. Increased marketing and manufacturing approaches to customize vehicles will increase the amount and variety of electronics, and of course, semiconductors in the vehicle. An excellent example is an office-on-wheels that has cellular phone, FAX, and printing capabilities as key accessories.

Achieving the goals of the auto manufacturer will require that automotive electronics and semiconductor manufacturers work together to provide fewer boxes, higher levels of integration, increased reliability, cost reduction (system, component, and assembly), surface-mount components, electronic replacements for mechanical components (relays, sensors, etc.), and reduced hardware and software design/development time.

The systems approach must be applied to a specific vehicle system, to the vehicle itself, the vehicle as a part of the transportation system, and, ultimately, as part of society (i.e., ecology, and the use of resources). A further understanding of the forces that are driving automotive electronics is gained by reviewing the changes that will occur by implementing IVHS, increased safety, the potential for antitheft/security, issues driving the EPA, consumer demands, and the effect of other industries on automotive electronics.

#### 32.4.1 Changes from IVHS

Worldwide efforts in intelligent vehicle-highway system (IVHS) will change the electronics in the vehicle and the way systems are configured (see Chap. 29). The goals of IVHS will determine the nature of hardware that is required: reducing traffic congestion; improving safety; enhancing mobility of travelers, especially the elderly and disabled; increasing the productivity of the transportation infrastructure; reducing energy use; reducing pollution; reducing capital and operating costs; increasing the viability of public transportation; responding more effectively to incidents; and increasing the ease and convenience of travel.

Achieving these goals will require several new vehicle and infrastructure systems and associated electronics to enable the control strategies. On the hardware side, sensors are the most critical enabling technology. However, software is predicted to be the most labor-intensive aspect of the development activities.

#### 32.4.2 Safety

Harry Mathew, a vehicle safety expert at Arthur D. Little, has made several predictions based on the need for improved safety in vehicles. Implementation of technologies that are discussed today is shown in Table 32.4. These areas and timing can be compared to projected penetration of super-smart vehicle systems (SSVS) in Japan that are shown in Table 32.5.

The emphasis that government and consumers place on aspects of vehicle technology will determine which elements are exploited in production vehicles. For example, the reporting of safety performance of vehicles in 35-mph frontal crashes by the National Highway Traffic Safety Administration (NHTSA) is intended to be a more consumer-oriented look at the probability of injury. This could result in even greater focus being placed on air bags, especially dual air bags and their effectiveness in preventing injuries by auto manufacturers.

**TABLE 32.4** Timing and Implementation of New Vehicle Systems

System/Technology	Timing
Air bags	Mandatory by 2010
Keyless entry	Widespread use by 2030
Remote control starting	Widespread use by 2030
Programmable position controls	Widespread use by 2030
Integrated traction control and ABS	2030
Addition of power steering to above	2060
IVHS	2050
Collision avoidance (radar & auto pilot)	Late 21st century

**TABLE 32.5** Penetration of SSVS Technologies in Automobiles

SSVS technology	Phase I yr 2000	Phase II yr 2010	Phase III yr 2020
Obstacle detection	20%	50%	80%
Road geometry detection	10%	40%	40%
Collision warning	10%	60%	80%
Auto braking/steering		10%	60%
Pedestrian detection		10%	60%
Driver assistance		10%	60%
Auto lane following			10%
Accident reduction	4%	20%	43%

**32.4.3 Antitheft/Security**

Antitheft equipment is an area that has developed from aftermarket implementation of products into OEM level. Auto theft cost American consumers nearly \$10 billion per year. NHSTA estimates that between 10 and 16 percent of auto thefts are by professional chop shops that strip and sell the parts. The effectiveness of antitheft systems against professional versus novice-level thieves is among the criteria that may have deterred their use by OEMs. However, electronic antitheft devices (see Chap. 24) are available that range from simple sensing and warning devices to cellular tracking systems with the ability to locate and disable the vehicle. For example, GM's Pass-Key™ system is offered as an OEM product and is expected to be installed on more than 40 percent of GM vehicles by 1995. Auto theft is a worldwide problem that varies in significance in other regions. This could be an area of increased usage and the target of integrated control strategy in the future for OEMs.

**32.4.4 EPA Driving Forces**

The top official in the EPA has the following issues to address:

- Finalize rules for on-board vapor recovery during refueling
- Monitor implementation of California's Low Emission Vehicle (LEV) program
- Determine whether Northeast states can adopt California's LEV standards
- Resolve third-car controversy (states adopting California LEV standards without California clean-fuel standards)
- Monitor phase-out of CFCs and phase-in of replacement coolants
- Finalize regulations for on-board diagnostic computers to monitor emission control systems
- Finalize rules for cold temperature carbon dioxide emissions controls
- Finalize rules for evaporative emission controls



The involvement of electronics and next-generation semiconductors to solve these problems has been discussed in several chapters.

### 32.4.5 Consumer Demands

A consumer survey of 1000 Southern California drivers indicated the following preferences for 1997 vehicle power sources with more than one choice possible: gasoline (34 percent), hybrid—electric and gasoline (29 percent), electric (26 percent), natural gas (16 percent), methanol (15 percent), diesel (4 percent), and don't know (7 percent). Satisfying these different vehicle preferences should be the target of manufacturers' product plans. Electric vehicles specifically require a broad range of semiconductor technology, some of which will be unique to the operating voltage of these vehicles. With growing concern for the environment, vehicle manufacturers can potentially segment their market and address a previously undefined customer.

Industry monitoring by groups like *Consumer Reports* of vehicle reliability can shift manufacturers' emphasis towards other items, such as owner satisfaction indices. Electronics has been recognized for its ability to provide more reliable automobiles in spite of the increased complexity.

### 32.4.6 Effect of Other Industries on Automotive Electronics

Looking outside the industry for technology driving forces can provide insight to avoid being blindsided by new approaches. Many of today's automotive controls result from the use of aerospace technology and displaced engineers during the 1970s. Today's use of military-developed technology, defense engineers, and national laboratories to develop next-generation hardware and software may change automotive systems. However, the computer industry is a prime mover of the highest level of integrated semiconductors and has over eight times the sales of automotive semiconductors. In the computer industry, the term *convergence* is being used to describe the merging of computing, communications, and consumer electronics that is occurring in new products aimed at highly portable computing.

The vehicle of the future could provide a docking/recharging station for a device that provides paging, cellular phone, digital notebook, calendar of events, personal tracking, FAX modem, and all the programs of a personal computer (pc), yet weighs only a few kilograms. The linkage of this unit to other vehicle systems could appeal to a new classification of automotive consumers. Manufacturers already have incorporated cellular phones into the steering wheel to provide a safer, more user-friendly means to dial. However, portable units that individuals will want to take to and from their vehicle will define new automotive products.

### 32.4.7 Software

Making the transition from one technology to the other and providing a transparent-to-the-driver feel for any future system will require extensive software. Three phases have been previously identified in the evolution of automotive electronics. Initial electronic components were diodes, transistors, and analog ICs in alternators, voltage regulators, AM-FM radios, and clocks. Phase II was the result of government regulations and enabled by the usage of microcontrollers in vehicle control systems. Phase III is marked by the use of smart peripherals, smart power drivers, and smart sensors, to bring the hardware closer to the capability of MCUs. The next phase will be the "software era," in which emphasis will be focused on standard open architecture; in-vehicle network backplane; factory, dealer, and consumer levels of configurability; neutral programming languages, and user-friendly software.

Advanced tools are required to deal with the increased level of software. From the semiconductor perspective, schematic capture, VHDL (VHSIC hardware description language)

simulation, and synthesis generator tools are already used with products like field-programmable gate arrays (FPGAs). The extension of electronic design automation (EDA) software linking control system requirements to silicon design is necessary to complete the process. This is only one part of the software issues. Others are increased memory = increased development time, code reliability/ruggedness, code portability/upward compatibility, tools for code development, verification/testing aspects including tools, software—the “differentiator” for future systems, software design cycle time reduction, software independent of hardware, and digital and analog simulation.

Along with more complex hardware and software comes the need for improved testability to ensure that these more complex systems work the way they were designed. Powertrain vehicle personalization, IVHS, and hybrid vehicles are expected to be even more important to future automotive growth than air bags and antilock braking systems were in the early 90s. Testing is critical during assembly, at the end of line, and in service. Design for testability (DFT) methodology must be implemented at the beginning of the design process to satisfy the full range of test requirements. Techniques have been developed, including boundary scan and built-in self-test (BIST), that must be utilized. The IEEE JTAG (Joint Test Access Group) standard, OBD-II, and others that may be developed must be implemented to allow equipment manufacturers a common methodology for developing new equipment.

Today's high-end microprocessor designs already have clock rates that exceed 80 MHz and are capable of executing several millions of instructions per second (MIPs). To utilize this, and even greater, capability in future automotive products, automotive designers will have to spend far more time developing software than they did in the previous generations of products. This will require a different approach to software—one that starts with a formal software department dedicated to developing structured code. Sophisticated debug and system integration tools developed for the semiconductor industry must be implemented in a networked environment to support and facilitate a team approach to software.

In addition to digital simulation, complex analog systems also require analysis techniques beyond those used in today's vehicles. A simulator, such as Analog's Saber™ simulator, can provide templates for various power supply topologies and evaluate virtual silicon prototypes in place of actual units to reduce cycle time and ensure adequate performance in production units.

EDA has been recognized for its ability to help vehicle manufacturers. Benefits that car makers are realizing include more effective and productive design engineers; parallel efforts in the design phase; simulation of more alternatives, early problem resolution, and optimization of final design; and the ability to incorporate more value-added electronic features for product differentiation.

The extent of interaction that must be analyzed and understood to provide future vehicle controls is extremely complex and will require several systems that simulate everything from vehicle combustion process to air bag deployment and driving simulation. Figure 32.8 shows a simple interrelation among the driver, his vehicle, and the environment. The ability to link together these systems and provide increased control to the driver will be the challenge for designers of future vehicles. This will require new semiconductor hardware, advanced development tools, and an unprecedented amount of software.

## 32.5 IMPACT ON FUTURE AUTOMOTIVE ELECTRONICS

Section 32.2.1 brought out the designer's role in future, sophisticated electronic systems. The enabling semiconductor technologies will be available. One potential system evolution path that could be taken to consolidate electronics in the passenger compartment is shown in Fig. 32.9. Given the level of complexity in the final stage, changes must be made in the way systems are designed.

A typical synthesis pipeline of today's design for digital electronics, which shows how an idea becomes a finished semiconductor product, is shown in Fig. 32.10. The RTL (register

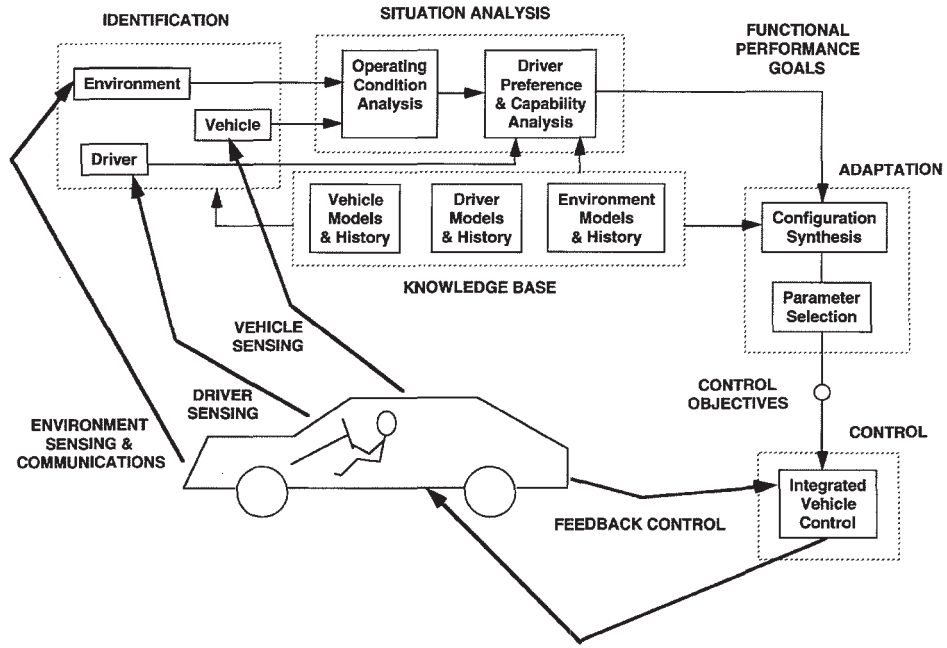

FIGURE 32.8 Vehicle, driver, and environment interrelationships.

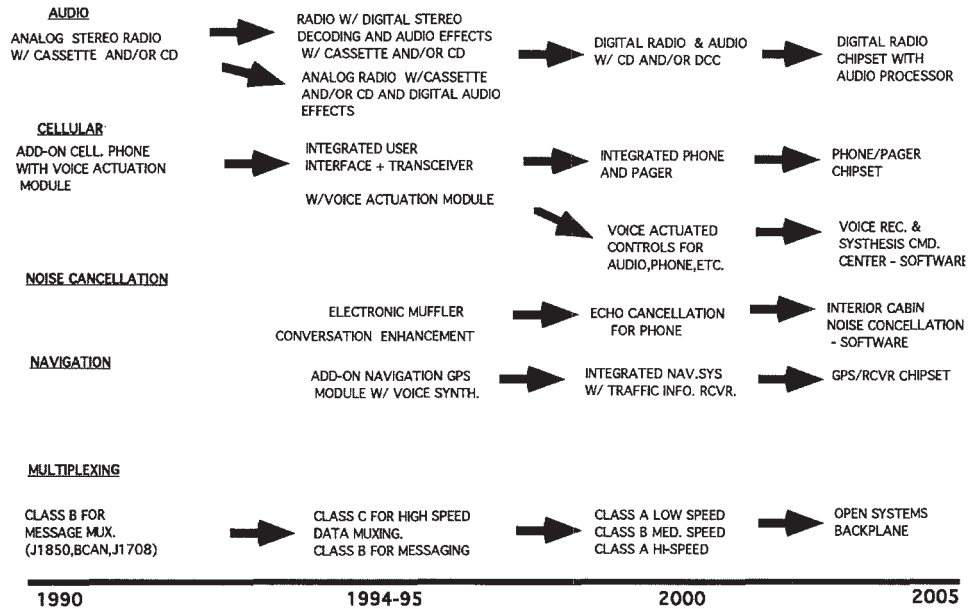

FIGURE 32.9 Audio, communication, navigation systems evolution.

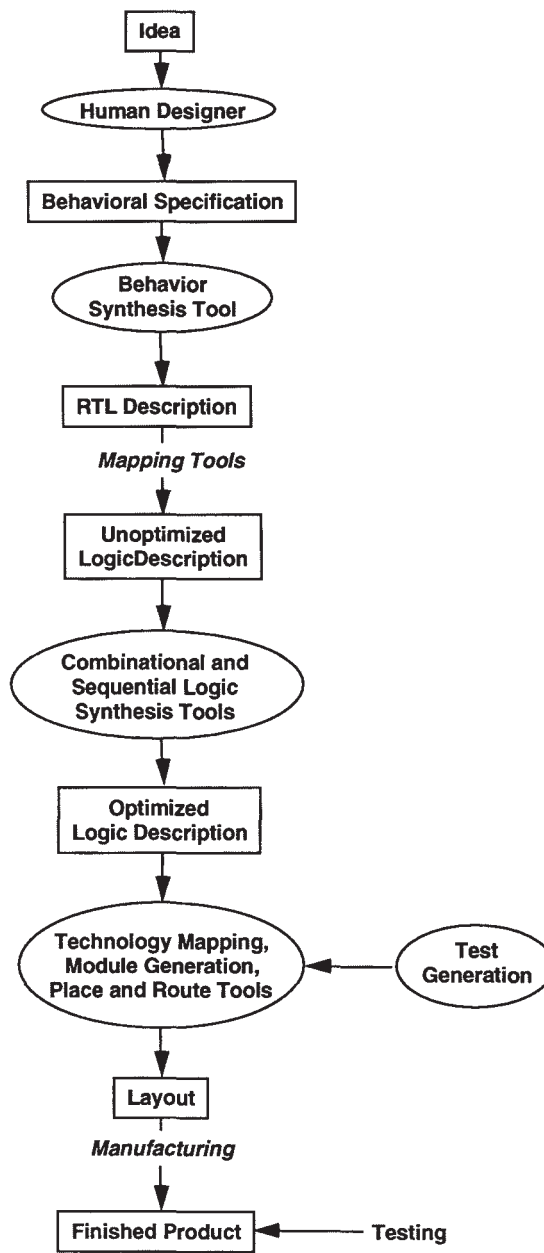

FIGURE 32.10 Typical synthesis pipeline of today's design of VLSI silicon chip.



transfer level) description is the area where the functionality of the ALUs (arithmetic logic units) and buses are specified by the chip architect. The RTL description is an interconnection of predefined modules such as adders, multipliers, or finite state machines that comprise controllers. The sequential logic description that accomplishes the desired behavior of the system is performed by logic designer(s). Finally, circuit designers optimize the transistor-level design created by logic designers.

Challenges in automating this process include the need for a new breed of designer, the system architect, who will have to simultaneously deal with software and hardware systems; unified formalism for specifying, analyzing, and designing mixed software/hardware systems; and development of design automation software to aid system-level partitioning.

The leading edge in today's electronics is demonstrated by the totally automated development of silicon based on the use of behavior synthesis and high-level physical design tools. DSP ICs have already been developed using AutoCircuit behavioral synthesis technology from General Motors R & D Center and high-level physical tools developed by Cascade Design Automation. IC engineers at Delco Electronics used Verilog language to describe the DSP algorithms. After simulating the algorithms, AutoCircuit converted them into a Verilog list of datapath modules, such as adders, subtractors, ALUs, and state machines. The Verilog net lists were fed directly into Cascade's tools, which automatically compiled all of the datapath modules and synthesized the state machine control-logic modules. The Cascade tools placed and routed the modules, and extracted post-layout timing information for gate-level timing simulation.

This approach will be used extensively in the development of future ICs. In addition, the linkage of the system(s) performance simulation to silicon generating systems will be required.

### 32.5.1 Changing Role of the Automotive Electronics Designer

Software will drive IC technology. At the same time, the automotive engineer's role will change. Already this role has changed from that of a board-level designer using transistors to one using integrated circuits. Today, a systems approach is being pursued, but the systems have to be designed with a top-down methodology. Product development with system engineering guidance is shown in Fig. 32.11. This is today's approach and probably will not significantly change from the organizational side, except for a stronger role for software development. However, the activities performed by these functions must change through the use of more interactive tools. Starting with the total concept for the car, every module, every subsystem, every piece of electronic technology must be considered. Integration, system partitioning, design functionality, and distributed versus centralized intelligence are part of this approach. Audio system evolution, shown in Fig. 32.12, provides an excellent example of the transition. This figure will be examined closer in the next section.

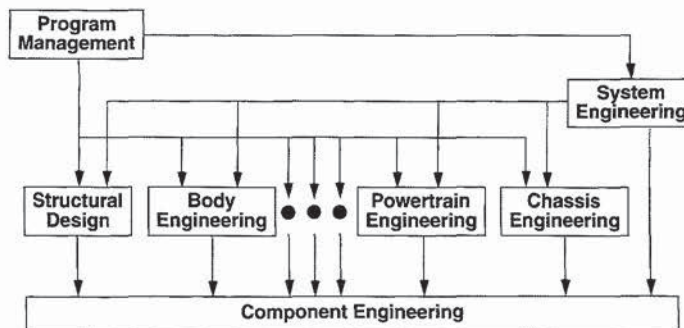

FIGURE 32.11 Product development with system engineering operation.

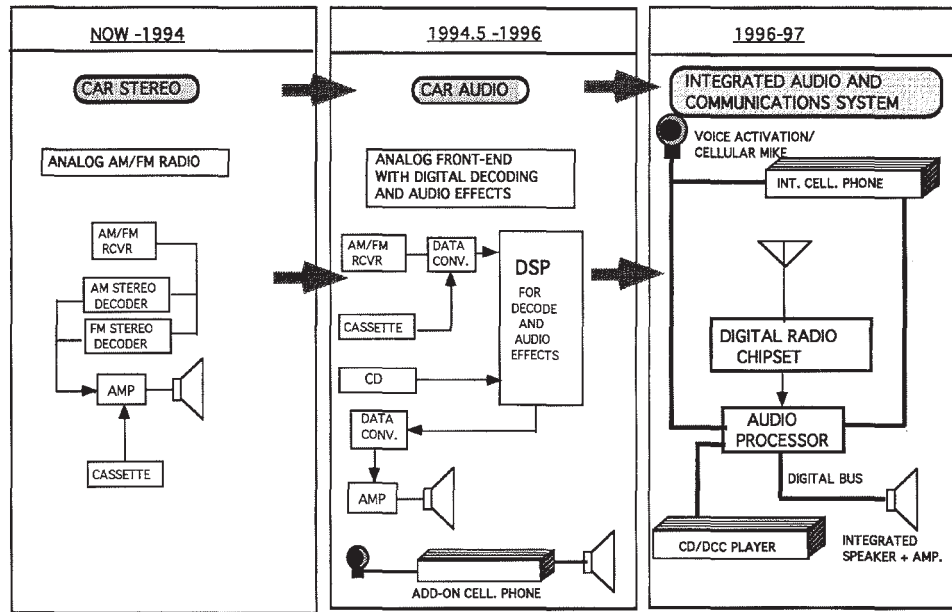

FIGURE 32.12 Audio evolution.

32.5.2 Potential System Architectures of the Future

It is apparent by now that the trend in automotive electronics is toward up-integration, with designers taking advantage of the compute power available, along with packaging technologies and adding more functionality to the modules. For example, engine management is being combined with cruise control and transmission control to form the powertrain controller. This trend is mainly driven by the need to reduce the cost of the modules—*value engineering* is the term being used, where value = function/cost. Value can be increased by either decreasing the cost of given functionality or by increasing functionality for the same cost. Integration then becomes a series of decisions or tradeoffs involving packaging, pc board, and semiconductor technologies. The designer continually makes cost/performance tradeoffs in selecting the technologies, and as technologies evolve, these tradeoffs must be updated.

So, given the technology scenario described earlier in this chapter, one can ask where will this evolution of up-integration end? Will everything eventually be integrated into a central control module? Or, given the trend in multiplexing, will ECUs be added ad infinitum, creating a distributed intelligence architecture? The answer is most probably “no” for both scenarios, and for several reasons, the key ones being cost effectiveness, reliability, heat dissipation, serviceability, and space requirements. The more likely scenario will be a combination of centralization and distributed intelligence where the centralization would be based along the lines of body, chassis and safety, powertrain, and audio/entertainment and communications. Within these centralized systems would be distributed intelligence based on multiplex wiring with smart sensors, switch decoders, and smart actuators all controlled by a central intelligence.

The strongest case for this scenario is the body system controller (refer to Table 32.1). Here functions such as door locks, interior dome lights, trunk lock, remote entry, antitheft alarm, electronic window lift, and electronic seat control with memory could all be centralized with multiplex wiring connecting the smart actuators (i.e., door locks, trunk release solenoids, etc.), switch decoders, and lamp and motor drivers. Another alternative to centralizing the whole



car into one system could be partitioning the system into four systems controlling the four quadrants of the vehicle. The multiplex wiring within each quadrant linking the switches and actuators could be class A type, while the quadrants could be interlinked with a class B multiplex bus for diagnostic purposes and to provide a gateway into the driver information system.

The audio/entertainment system is probably the most interesting system from an architecture viewpoint because of how it has evolved, its uniqueness from the standpoint of standardization, and the possibilities that integrated semiconductor technology could provide. To understand the possibilities, let's examine how the radio has evolved. As shown in Fig. 32.12, the initial analog-based AM radio has integrated functions to include stereo (both AM and FM) and cassette or compact disc (CD) in the early 90s. Audio effects similar to ones found in home stereo systems are made possible with DSPs and are being offered on high-end vehicles today. With the availability of high-resolution, high-speed data conversion devices (e.g., 16- to 18-bit sigma-delta A/Ds and D/As), the radio will move from the analog domain to a digital domain, with the DSPs performing the task of AM/FM stereo decoding along with the audio effects.

A new dimension to the car audio system has been the addition of cellular phones. Instead of being an add-on aftermarket feature, the cellular phone is being integrated into the audio system. Bosch and Pioneer both have introduced stereo systems with the cellular phone integrated. This integration allows features such as automatic muting of the radio when a call comes in and better quality sound because the phone now uses the audio speakers instead of its own tiny speaker. The next feature to be added to the audio system will be global positioning system (GPS) based navigation.

In the next few years all three functions—radio/audio, cellular phone, and GPS receivers—will be reduced to single-chip functions or chipsets. The system designer will then design a motherboard for an audio/phone/navigation system where each function could be offered simply by putting in the chipset—the plug-and-play concept similar to that used in the pc world. Taking this one step further, if all three functions were made available as a standard package, the system designer could take a total systems approach and develop one chip or chipset and implement the three functions in software. This would eliminate redundant computing power from the three-function chipsets scenario. This is possible because at any given time either the radio/audio system or the phone would be functioning, and the same hardware could handle the functions with context-switching software. Since the GPS receiver function is not time critical, it could be handled again by the same hardware on a cycle-stealing basis. Features such as voice recognition could also be added in software. The designer would need to develop an operating system to handle all the function switching and the user interface—perhaps, the automotive operating systems (AOS). Again, the analogy of the pc world is appropriate.

This would lead us to conclude that software is going to play an increasingly important role in future automotive electronics. Given that the capability of the semiconductor industry and the IC design tools will evolve, the differentiating factor will be software.

## 32.6 CONCLUSIONS

A universally accepted approach to electronics in all regions of the world does not appear very likely. Europe, North America, Japan, and other regions of the world have differences in use and design that are obvious in the electronic requirements. Europe may be the most likely to favor a backplane approach. In the United States, captive electronics support can provide individuality, but independent electronic suppliers in Europe support several different automotive customers in several countries with a wide range of requirements. Obviously, this requires standards that allow users to specify within the capabilities of several suppliers and still configure the functions that are required.

With rapid advances that are occurring in research, the technology of choice for semiconductors is a moving target which can change in the present design cycle time for vehicles. Problems for one approach can be solved, making it a viable alternative. Based on the kinds of systems that will drive future vehicle technology, and the potential for more drive power options—four- or two-stroke internal combustion, electric, hybrid and diesel—automobile manufacturers will continue to look to electronics and semiconductor technology to provide cost-effective solutions. Software will be the next frontier for semiconductor, electronics, and automotive manufacturers.

This chapter has described activities that are occurring or are likely to occur based on information that is widely discussed in public electronic and automotive forums. Several sources of new information that will provide an update or revise these projections can be found in:

- Semiconductor Industry Association (SIA) reports
- Proceedings of International Congress on Transportation Electronics (Convergence)
- University of Michigan Delphi Report (Rev. VII or later)
- Morgan Stanley research
- Hansen Report on automotive electronics, published monthly
- BIS strategic decisions
- Arthur D. Little reports
- *Inside IVHS*, published biweekly
- Automotive periodicals (e.g., *Automotive Engineering*, *Automotive Industries*, *Automotive News*, *Ward's Auto World*)
- Electronics periodicals (e.g., *EE Times*, *Electronic Design*, *Electronic Design News*, *IEEE Spectrum*)
- Other SAE or IEEE publications

SMARTMOS, Seamless Silicon System, System Chip, and SENSEFET are trademarks of Motorola, Inc. Saber is a trademark of Analogy, Inc. Pass-Key is a trademark of General Motors. All other trademarks are the property of their respective owners.

## GLOSSARY

---

**ASIC** Application-specific integrated circuit, an IC designed for a custom requirement, frequently a gate array or programmable logic device.

**ATPG** Automation test program/pattern generator.

**BIST** Built-in self-test, design technique that allows a chip to be tested for a guaranteed level of functionality.

**CISC** Complex instruction set computer, standard computing approach as compared to RISC architecture.

**Combinational technologies** Integrated mixed-signal, analog and digital technology.

**DFT** Design for testability, methodology that takes test requirements into account early in the design process.

**EPROM** Erasable programmable read-only memory, a semiconductor technique used for permanent storage but can be erased by ultraviolet light.

**EEPROM** Electrically erasable programmable read-only memory, a semiconductor technique used for permanent storage. It can be reprogrammed in the system.



- Engine (micro engine)** The computational portion of an IC.
- Flash** Semiconductor memory, faster than EEPROM, that can be used for permanent storage and is easily electrically reprogrammed in the system.
- Flops** Floating-point operations per second, a measurement of microprocessor performance.
- FPGA** Field-programmable gate array, an IC that can be programmed.
- Harvard architecture** On-chip program and data are in two separate spaces and are carried in parallel by two separate buses.
- HDL** Hardware description language.
- HLL** High-level language, a programming language that utilizes macro statements and instructions that closely resemble human language or mathematical notation to describe the problem to be solved or the procedure to be used.
- Integration** The combination of previous levels of separate circuit designs.
- Mechatronics** The combination of mechanical and electronic technology as in motor controls.
- MESFET (metal semiconductor field effect transistor)** A high-frequency semiconductor device produced in GaAs semiconductor technology.
- Micromachining** The chemical etching of mechanical structures in silicon, or other semiconductor material, usually to produce a sensor or actuator.
- Mips** Millions of instructions per second, a measurement of microprocessor throughput.
- Mixed-signal** The combination of analog and digital circuitry in a single semiconductor process.
- Multiprocessing** The simultaneous execution of two or more instructions by a computer.
- MCU** Microcontrol unit, or microcontroller unit, a semiconductor that has both a CPU, memory, and I/O capability on the same chip.
- MMIC** Monolithic microwave integrated circuit, a high-frequency integrated circuit.
- Partitioning** System design methodology that determines which portion of the circuit is integrated using a particular silicon process instead of completely integrating design using one process.
- Pipeline** Bus structure within an MPU that allows concurrent operations to occur.
- Protocol** The rules governing the exchange of data between networked elements.
- RISC** Reduced instruction set computer, a CPU architecture which optimizes processing speed by the use of a smaller number of basic machine instructions.
- Scalable** Ability of MCU or MPU architecture to be modified to meet the needs of several applications providing competitive price-performance points.
- Silicon compiler** A tool that translates algorithms into a design layout for silicon.
- SMD** Surface-mount device (see **SMT**).
- SMT** Surface-mount technology, method of attaching components, both electrically and mechanically, to the surface of a conductive pattern.
- SPECfp92** Floating-point benchmark test and rating (1992) for comparing microprocessor computing power.
- SPECint92** Integer benchmark test and rating (1992) for comparing microprocessor computing power.

**State machine** Logic circuitry that when clocked sequences through logical operations and can be a preprogrammed set of instructions or logic states.

**SSVS** Super-smart vehicle systems, term used in Japan for vehicles with several new electronic systems, typically used in IVHS.

**Submicron** Measurement of the geometries or critical spacing used for complex, highly integrated circuits.

**Superscalar** The ability of an MPU to dispatch multiple instructions per clock from a conventional linear instruction stream.

**Verilog** A hardware description language for behavior-level circuit design placed in public domain by Cadence Design Systems Inc.

**VHDL** VHSIC Hardware Description Language, a hardware description language for behavior-level circuit design developed by the U.S. Department of Defense.

**Von Neumann (architecture)** Program and data are carried sequentially on the same bus.

## BIBLIOGRAPHY

---

- "Behavior Synthesis Yields Working Silicon," *Electronic Design*, Dec. 2, 1993, p. 28.
- Benson, M., R. Frank, J. Jandu, and M. Shaw, *Proceedings of Sensors Expo 1993*, Philadelphia, Pa., Oct. 26-28, 1993, pp. 133-143.
- "Circuits don't need substrates at UCLA," Technology News section of *Solid State Technology*, Dec. 1993, pp. 18-19.
- Devadas, S., "Microelectronic System Design Skills for the Year 2000 and Beyond," *Journal of Microelectronic Systems Integration*, vol. 1, no. 1, 1993, pp. 85-95.
- "EDA: An Emerging Competitive Weapon," *The Hansen Report*, July/August 1992.
- Faubert, R., "Mainstream logic designers need to master new hardware and software design skills," *IEEE Spectrum*, p. 57.
- Fleming, William, "Automotive Electronics," *IEEE Vehicular Technology Society News*, May 1993, pp. 32-34.
- Gates, M., "EPA nominee is tough on environment, open to ideas," *Automotive News*, July 26, 1993, p. 4.
- Schilke, N. A., et al., "Integrated Vehicle Controls," *Proceedings of 1988 International Congress on Transportation Electronics*, IEEE 88CH2533-8, Dearborn, Mich., Oct. 17-18, 1988, pp. 97-106.
- SIA Semiconductor Technology, Workshop Working Group Reports, San Jose, Calif., 1993.
- "Systems Engineering: and Update," *Automotive Engineering*, Feb. 1992, pp. 65-66.
- Wilhelm, R. V., E. M. Norppa, and K. D. Casey, "Voice of the Customer Linkages to Powertrain Controller Design," *Proceedings of 1992 International Congress on Transportation Electronics*, SAE, Warrendale, Pa., Oct., 1992, pp. 253-258.

## ABOUT THE AUTHORS

RANDY FRANK (see biography at the end of Chap. 2).

SALIM MOMIN is director of market development, Automotive Segment, Semiconductor Product Systems, Motorola Inc. His main function is strategic marketing and technology planning. He started his career with Chrysler Corp., working on the first fuel-injected turbocharged engine. At Gulf & Western Mfg. Co., he developed electronic modules for the automotive industry. He holds two patents for his work at Chrysler.

