

Chapter 12

value?

by the

on one  
multicast

of the

nod to

multi-

ce has  
OK?

tion is

used to

# 13

## ***IGMP: Internet Group Management Protocol***

### **13.1 Introduction**

IGMP conveys group membership information between hosts and routers on a local network. Routers periodically multicast IGMP queries to the all-hosts group. Hosts respond to the queries by multicasting IGMP report messages. The IGMP specification appears in RFC 1112. Chapter 13 of Volume 1 describes the specification of IGMP and provides some examples.

From an architecture perspective, IGMP is a transport protocol above IP. It has a protocol number (2) and its messages are carried in IP datagrams (as with ICMP). IGMP usually isn't accessed directly by a process but, as with ICMP, a process can send and receive IGMP messages through an IGMP socket. This feature enables multicast routing daemons to be implemented as user-level processes.

Figure 13.1 shows the overall organization of the IGMP protocol in Net/3.

The key to IGMP processing is the collection of `in_multi` structures shown in the center of Figure 13.1. An incoming IGMP query causes `igmp_input` to initialize a countdown timer for each `in_multi` structure. The timers are updated by `igmp_fasttimo`, which calls `igmp_sendreport` as each timer expires.

We saw in Chapter 12 that `ip_setmoptions` calls `igmp_joyingroup` when a new `in_multi` structure is created. `igmp_joyingroup` calls `igmp_sendreport` to announce the new group and enables the group's timer to schedule a second announcement a short time later. `igmp_sendreport` takes care of formatting an IGMP message and passing it to `ip_output`.

On the left and right of Figure 13.1 we see that a raw socket can send and receive IGMP messages directly.

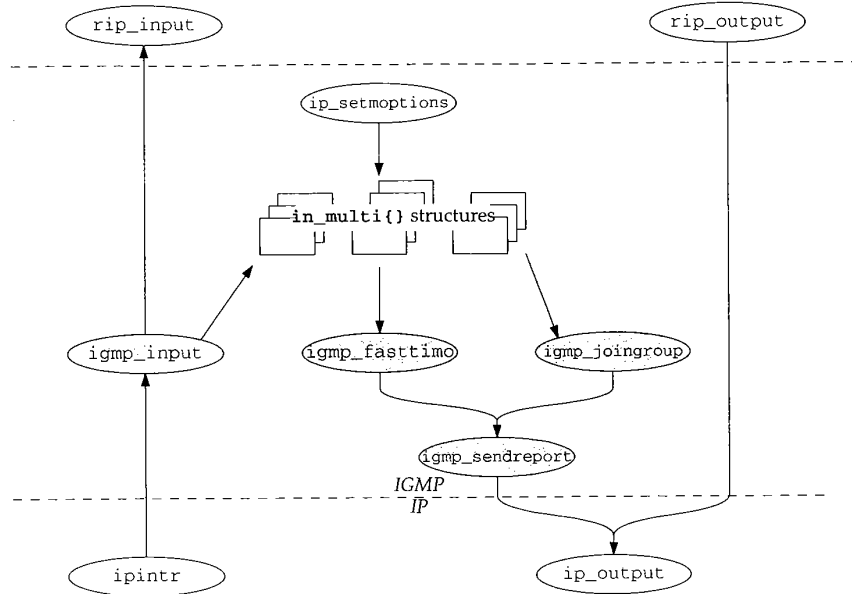

Figure 13.1 Summary of IGMP processing.

### 13.2 Code Introduction

The IGMP protocol is implemented in four files listed in Figure 13.2.

File	Description
netinet/igmp.h	IGMP protocol definitions
netinet/igmp_var.h	IGMP implementation definitions
netinet/in_var.h	IP multicast data structures
netinet/igmp.c	IGMP protocol implementation

Figure 13.2 Files discussed in this chapter.

#### Global Variables

Three new global variables, shown in Figure 13.3, are introduced in this chapter.

#### Statistics

IGMP statistics are maintained in the `igmpstat` variables shown in Figure 13.4.

SNMP

Variable	Datatype	Description
igmp_all_hosts_group	u_long	all-hosts group address in network byte order
igmp_timers_are_running	int	true if any IGMP timer is active, false otherwise
igmpstat	struct igmpstat	IGMP statistics (Figure 13.4).

Figure 13.3 Global variables introduced in this chapter.

igmpstat member	Description
igps_rcv_badqueries	#messages received as invalid queries
igps_rcv_badreports	#messages received as invalid reports
igps_rcv_badsum	#messages received with bad checksum
igps_rcv_ourreports	#messages received as reports for local groups
igps_rcv_queries	#messages received as membership queries
igps_rcv_reports	#messages received as membership reports
igps_rcv_tooshort	#messages received with too few bytes
igps_rcv_total	total #IGMP messages received
igps_snd_reports	#messages sent as membership reports

Figure 13.4 IGMP statistics.

Figure 13.5 shows some sample output of these statistics, from the `netstat -p igmp` command on `vangogh.cs.berkeley.edu`.

netstat -p igmp output	igmpstat member
18774 messages received	igps_rcv_total
0 messages received with too few bytes	igps_rcv_tooshort
0 messages received with bad checksum	igps_rcv_badsum
18774 membership queries received	igps_rcv_queries
0 membership queries received with invalid field(s)	igps_rcv_badqueries
0 membership reports received	igps_rcv_reports
0 membership reports received with invalid field(s)	igps_rcv_badreports
0 membership reports received for groups to which we belong	igps_rcv_ourreports
0 membership reports sent	igps_snd_reports

Figure 13.5 Sample IGMP statistics.

From Figure 13.5 we can tell that `vangogh` is attached to a network where IGMP is being used, but that `vangogh` is not joining any multicast groups, since `igps_snd_reports` is 0.

### SNMP Variables

There is no standard SNMP MIB for IGMP, but [McCloghrie and Farinacci 1994a] describes an experimental MIB for IGMP.

### 13.3 igmp Structure

An IGMP message is only 8 bytes long. Figure 13.6 shows the `igmp` structure used by Net/3.

```

43 struct igmp {
44     u_char  igmp_type;           /* version & type of IGMP message */
45     u_char  igmp_code;          /* unused, should be zero          */
46     u_short igmp_cksum;         /* IP-style checksum              */
47     struct in_addr igmp_group; /* group address being reported   */
48 };

```

*igmp.h*

Figure 13.6 `igmp` structure.

43-44 A 4-bit version code and a 4-bit type code are contained within `igmp_type`. Figure 13.7 shows the standard values.

Version	Type	igmp_type	Description
1	1	0x11 (IGMP_HOST_MEMBERSHIP_QUERY)	membership query
1	2	0x12 (IGMP_HOST_MEMBERSHIP_REPORT)	membership report
1	3	0x13	DVMRP message (Chapter 14)

Figure 13.7 IGMP message types.

Only version 1 messages are used by Net/3. Multicast routers send type 1 (IGMP\_HOST\_MEMBERSHIP\_QUERY) messages to solicit membership reports from hosts on the local network. The response to a type 1 IGMP message is a type 2 (IGMP\_HOST\_MEMBERSHIP\_REPORT) message from the hosts reporting their multicast membership information. Type 3 messages transport multicast routing information between routers (Chapter 14). A host never processes type 3 messages. The remainder of this chapter discusses only type 1 and 2 messages.

45-46 `igmp_code` is unused in IGMP version 1, and `igmp_cksum` is the familiar IP checksum computed over all 8 bytes of the IGMP message.

47-48 `igmp_group` is 0 for queries. For replies, it contains the multicast group being reported.

Figure 13.8 shows the structure of an IGMP message relative to an IP datagram.

### 13.4 IGMP protosw Structure

Figure 13.9 describes the `protosw` structure for IGMP.

Although it is possible for a process to send raw IP packets through the IGMP `protosw` entry, in this chapter we are concerned only with how the kernel processes IGMP messages. Chapter 32 discusses how a process can access IGMP using a raw socket.

ed by

igmp.h

igmp.h

. Fig-

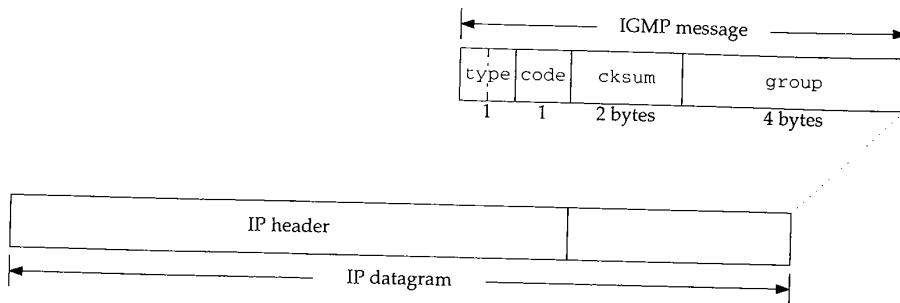

Figure 13.8 An IGMP message (igmp\_omitted).

ype 1

hosts

ype 2

lticast

ation

inder

iar IP

being

1.

IGMP

cesses

a raw

Member	inetsw[5]	Description
pr_type	<i>SOCK_RAW</i>	IGMP provides raw packet services
pr_domain	<i>&amp;inetdomain</i>	IGMP is part of the Internet domain
pr_protocol	<i>IPPROTO_IGMP (2)</i>	appears in the <i>ip_p</i> field of the IP header
pr_flags	<i>PR_ATOMIC PR_ADDR</i>	socket layer flags, not used by protocol processing
pr_input	<i>igmp_input</i>	receives messages from IP layer
pr_output	<i>rip_output</i>	sends IGMP message to IP layer
pr_ctlinput	<i>0</i>	not used by IGMP
pr_ctloutput	<i>rip_ctloutput</i>	respond to administrative requests from a process
pr_usrreq	<i>rip_usrreq</i>	respond to communication requests from a process
pr_init	<i>igmp_init</i>	initialization for IGMP
pr_fasttimo	<i>igmp_fasttimo</i>	process pending membership reports
pr_slowtimo	<i>0</i>	not used by IGMP
pr_drain	<i>0</i>	not used by IGMP
pr_sysctl	<i>0</i>	not used by IGMP

Figure 13.9 The IGMP protocol structure.

There are three events that trigger IGMP processing:

- a local interface has joined a new multicast group (Section 13.5),
- an IGMP timer has expired (Section 13.6), and
- an IGMP query is received (Section 13.7).

There are also two events that trigger local IGMP processing but do not result in any messages being sent:

- an IGMP report is received (Section 13.7), and
- a local interface leaves a multicast group (Section 13.8).

These five events are discussed in the following sections.

### 13.5 Joining a Group: `igmp_joiningroup` Function

We saw in Chapter 12 that `igmp_joiningroup` is called by `in_addmulti` when a new `in_multi` structure is created. Subsequent requests to join the same group only increase the reference count in the `in_multi` structure; `igmp_joiningroup` is not called. `igmp_joiningroup` is shown in Figure 13.10

```

164 void
165 igmp_joiningroup(inm)
166 struct in_multi *inm;
167 {
168     int     s = splnet();
169     if (inm->inm_addr.s_addr == igmp_all_hosts_group ||
170         inm->inm_ifp == &loif)
171         inm->inm_timer = 0;
172     else {
173         igmp_sendreport(inm);
174         inm->inm_timer = IGMP_RANDOM_DELAY(inm->inm_addr);
175         igmp_timers_are_running = 1;
176     }
177     splx(s);
178 }

```

*igmp.c*

Figure 13.10 `igmp_joiningroup` function.

164-178 `inm` points to the new `in_multi` structure for the group. If the new group is the all-hosts group, or the membership request is for the loopback interface, `inm_timer` is disabled and `igmp_joiningroup` returns. Membership in the all-hosts group is never reported, since every multicast host is assumed to be a member of the group. Sending a membership report to the loopback interface is unnecessary, since the local host is the only system on the loopback network and it already knows its membership status.

In the remaining cases, a report is sent immediately for the new group, and the group timer is set to a random value based on the group. The global flag `igmp_timers_are_running` is set to indicate that at least one timer is enabled. `igmp_fasttimo` (Section 13.6) examines this variable to avoid unnecessary processing.

When the timer for the new group expires, a second membership report is issued. The duplicate report is harmless, but it provides insurance in case the first report is lost or damaged. The report delay is computed by `IGMP_RANDOM_DELAY` (Figure 13.11).

59-73 According to RFC 1122, report timers should be set to a random time between 0 and 10 (`IGMP_MAX_HOST_REPORT_DELAY`) seconds. Since IGMP timers are decremented five (`PR_FASTHZ`) times per second, `IGMP_RANDOM_DELAY` must pick a random value between 1 and 50. If  $r$  is the random number computed by adding the total number of IP packets received, the host's primary IP address, and the multicast group, then

$$0 \leq (r \bmod 50) \leq 49$$

and

$$1 \leq (r \bmod 50) + 1 \leq 50$$

```

59 /*-----igmp_var.h
60 * Macro to compute a random timer value between 1 and (IGMP_MAX_REPORTING_
61 * DELAY * countdown frequency). We generate a "random" number by adding
62 * the total number of IP packets received, our primary IP address, and the
63 * multicast address being timed-out. The 4.3 random() routine really
64 * ought to be available in the kernel!
65 */
66 #define IGMP_RANDOM_DELAY(multiaddr) \
67     /* struct in_addr multiaddr; */ \
68     ( (ipstat.ips_total + \
69        ntohl(IA_SIN(in_ifaddr)->sin_addr.s_addr) + \
70         ntohl((multiaddr).s_addr) \
71         ) \
72         % (IGMP_MAX_HOST_REPORT_DELAY * PR_FASTHZ) + 1 \
73         )
-----igmp_var.h

```

Figure 13.11 IGMP\_RANDOM\_DELAY function.

Zero is avoided because it would disable the timer and no report would be sent.

### 13.6 igmp\_fasttimo Function

Before looking at `igmp_fasttimo`, we need to describe the mechanism used to traverse the `in_multi` structures.

To locate each `in_multi` structure, Net/3 must traverse the `in_multi` list for each interface. During a traversal, an `in_multistep` structure (shown in Figure 13.12) records the position.

```

123 struct in_multistep {-----in_var.h
124     struct in_ifaddr *i_ia;
125     struct in_multi *i_inm;
126 };
-----in_var.h

```

Figure 13.12 `in_multistep` function.

123-126 `i_ia` points to the *next* `in_ifaddr` interface structure and `i_inm` points to the *next* `in_multi` structure for the *current* interface.

The `IN_FIRST_MULTI` and `IN_NEXT_MULTI` macros (shown in Figure 13.13) traverse the lists.

154-169 If the `in_multi` list has more entries, `i_inm` is advanced to the next entry. When `IN_NEXT_MULTI` reaches the end of a multicast list, `i_ia` is advanced to the next interface and `i_inm` to the first `in_multi` structure associated with the interface. If the interface has no multicast structures, the while loop continues to advance through the interface list until all interfaces have been searched.

170-177 The `in_multistep` array is initialized to point to the first `in_ifaddr` structure in the `in_ifaddr` list and `i_inm` is set to null. `IN_NEXT_MULTI` finds the first `in_multi` structure.

```

147 /*
148  * Macro to step through all of the in_multi records, one at a time.
149  * The current position is remembered in "step", which the caller must
150  * provide. IN_FIRST_MULTI(), below, must be called to initialize "step"
151  * and get the first record. Both macros return a NULL "inm" when there
152  * are no remaining records.
153  */
154 #define IN_NEXT_MULTI(step, inm) \
155     /* struct in_multistep step; */ \
156     /* struct in_multi *inm; */ \
157 { \
158     if (((inm) = (step).i_inm) != NULL) \
159         (step).i_inm = (inm)->inm_next; \
160     else \
161         while ((step).i_ia != NULL) { \
162             (inm) = (step).i_ia->ia_multiaddr; \
163             (step).i_ia = (step).i_ia->ia_next; \
164             if ((inm) != NULL) { \
165                 (step).i_inm = (inm)->inm_next; \
166                 break; \
167             } \
168         } \
169 }

170 #define IN_FIRST_MULTI(step, inm) \
171     /* struct in_multistep step; */ \
172     /* struct in_multi *inm; */ \
173 { \
174     (step).i_ia = in_ifaddr; \
175     (step).i_inm = NULL; \
176     IN_NEXT_MULTI((step), (inm)); \
177 }

```

Figure 13.13 IN\_FIRST\_MULTI and IN\_NEXT\_MULTI structures.

We know from Figure 13.9 that `igmp_fasttimo` is the fast timeout function for IGMP and is called five times per second. `igmp_fasttimo` (shown in Figure 13.14) decrements multicast report timers and sends a report when the timer expires.

187-198 If `igmp_timers_are_running` is false, `igmp_fasttimo` returns immediately instead of wasting time examining each timer.

199-213 `igmp_fasttimo` resets the running flag and then initializes `step` and `inm` with `IN_FIRST_MULTI`. The `igmp_fasttimo` function locates each `in_multi` structure with the while loop and the `IN_NEXT_MULTI` macro. For each structure:

- If the timer is 0, there is nothing to be done.
- If the timer is nonzero, it is decremented. If it reaches 0, an IGMP membership report is sent for the group.
- If the timer is still nonzero, then at least one timer is still running, so `igmp_timers_are_running` is set to 1.



\_var.h

>"  
≥

```

187 void
188 igmp_fasttimo()
189 {
190     struct in_multi *inm;
191     int s;
192     struct in_multistep step;
193     /*
194      * Quick check to see if any work needs to be done, in order
195      * to minimize the overhead of fasttimo processing.
196      */
197     if (!igmp_timers_are_running)
198         return;
199     s = splnet();
200     igmp_timers_are_running = 0;
201     IN_FIRST_MULTI(step, inm);
202     while (inm != NULL) {
203         if (inm->inm_timer == 0) {
204             /* do nothing */
205         } else if (--inm->inm_timer == 0) {
206             igmp_sendreport(inm);
207         } else {
208             igmp_timers_are_running = 1;
209         }
210         IN_NEXT_MULTI(step, inm);
211     }
212     splx(s);
213 }

```

igmp.c

Figure 13.14 igmp\_fasttimo function.

i\_var.h

**igmp\_sendreport Function**

The `igmp_sendreport` function (shown in Figure 13.15) constructs and sends an IGMP report message for a single multicast group.

214-232 The single argument `inm` points to the `in_multi` structure for the group being reported. `igmp_sendreport` allocates a new mbuf and prepares it for an IGMP message. `igmp_sendreport` leaves room for a link-layer header and sets the length of the mbuf and packet to the length of an IGMP message.

233-245 The IP header and IGMP message is constructed one field at a time. The source address for the datagram is set to `INADDR_ANY`, and the destination address is the multicast group being reported. `ip_output` replaces `INADDR_ANY` with the unicast address of the outgoing interface. Every member of the group receives the report as does every multicast router (since multicast routers receive *all* IP multicasts).

246-260 Finally, `igmp_sendreport` constructs an `ip_moptions` structure to go along with the message sent to `ip_output`. The interface associated with the `in_multi` structure is selected as the outgoing interface; the TTL is set to 1 to keep the report on the local network; and, if the local system is configured as a router, multicast loopback is enabled for this request.

on for  
13.14)

liately

with  
cture

ership

ig, so

```

214 static void
215 igmp_sendreport(inm)
216 struct in_multi *inm;
217 {
218     struct mbuf *m;
219     struct igmp *igmp;
220     struct ip *ip;
221     struct ip_moptions *imo;
222     struct ip_moptions simo;

223     MGETHDR(m, M_DONTWAIT, MT_HEADER);
224     if (m == NULL)
225         return;
226     /*
227      * Assume max_linkhdr + sizeof(struct ip) + IGMP_MINLEN
228      * is smaller than mbuf size returned by MGETHDR.
229      */
230     m->m_data += max_linkhdr;
231     m->m_len = sizeof(struct ip) + IGMP_MINLEN;
232     m->m_pkthdr.len = sizeof(struct ip) + IGMP_MINLEN;

233     ip = mtod(m, struct ip *);
234     ip->ip_tos = 0;
235     ip->ip_len = sizeof(struct ip) + IGMP_MINLEN;
236     ip->ip_off = 0;
237     ip->ip_p = IPPROTO_IGMP;
238     ip->ip_src.s_addr = INADDR_ANY;
239     ip->ip_dst = inm->inm_addr;

240     igmp = (struct igmp *) (ip + 1);
241     igmp->igmp_type = IGMP_HOST_MEMBERSHIP_REPORT;
242     igmp->igmp_code = 0;
243     igmp->igmp_group = inm->inm_addr;
244     igmp->igmp_cksum = 0;
245     igmp->igmp_cksum = in_cksum(m, IGMP_MINLEN);

246     imo = &simo;
247     bzero((caddr_t) imo, sizeof(*imo));
248     imo->imo_multicast_ifp = inm->inm_ifp;
249     imo->imo_multicast_ttl = 1;

250     /*
251      * Request loopback of the report if we are acting as a multicast
252      * router, so that the process-level routing demon can hear it.
253      */
254     {
255         extern struct socket *ip_mrouter;
256         imo->imo_multicast_loop = (ip_mrouter != NULL);
257     }
258     ip_output(m, NULL, NULL, 0, imo);

259     ++igmpstat.igps_snd_reports;
260 }

```

Figure 13.15 igmp\_sendreport function.

The process-level multicast router must hear the membership reports. In Section 12.14 we saw that IGMP datagrams are always accepted when the system is configured as a multicast router. Through the normal transport demultiplexing code, the messages are passed to `igmp_input`, the `pr_input` function for IGMP (Figure 13.9).

### 13.7 Input Processing: `igmp_input` Function

In Section 12.14 we described the multicast processing portion of `ipintr`. We saw that a multicast router accepts *any* IGMP message, but a multicast host accepts only IGMP messages that arrive on an interface that is a member of the destination multicast group (i.e., queries and membership reports for which the receiving interface is a member).

The accepted messages are passed to `igmp_input` by the standard protocol demultiplexing mechanism. The beginning and end of `igmp_input` are shown in Figure 13.16. The code for each IGMP message type is described in following sections.

#### Validate IGMP message

52-96 The function `ipintr` passes `m`, a pointer to the received packet (stored in an mbuf), and `iphlen`, the size of the IP header in the datagram.

The datagram must be large enough to contain an IGMP message (`IGMP_MINLEN`), must be contained within a standard mbuf header (`m_pullup`), and must have a correct IGMP checksum. If any errors are found, they are counted, the datagram is silently discarded, and `igmp_input` returns.

The body of `igmp_input` processes the validated messages based on the code in `igmp_type`. Remember from Figure 13.6 that `igmp_type` includes a version code and a type code. The switch statement is based on the combined value stored in `igmp_type` (Figure 13.7). Each case is described separately in the following sections.

#### Pass IGMP messages to raw IP

157-163 There is no default case for the switch statement. Any valid message (i.e., one that is properly formed) is passed to `rip_input` where it is delivered to any process listening for IGMP messages. IGMP messages with versions or types that are unrecognized by the kernel can be processed or discarded by the listening processes.

The `mouted` program depends on this call to `rip_input` so that it receives membership queries and reports.

#### Membership Query: `IGMP_HOST_MEMBERSHIP_QUERY`

RFC 1075 recommends that multicast routers issue an IGMP membership query at least once every 120 seconds. The query is sent to group 224.0.0.1 (the all-hosts group). Figure 13.17 shows how the message is processed by a host.

igmp.c

```

52 void
53 igmp_input(m, iphlen)
54 struct mbuf *m;
55 int    iphlen;
56 {
57     struct igmp *igmp;
58     struct ip *ip;
59     int    igmplen;
60     struct ifnet *ifp = m->m_pkthdr.rcvif;
61     int    minlen;
62     struct in_multi *inm;
63     struct in_ifaddr *ia;
64     struct in_multistep step;

65     ++igmpstat.igps_rcv_total;

66     ip = mtod(m, struct ip *);
67     igmplen = ip->ip_len;

68     /*
69      * Validate lengths
70      */
71     if (igmplen < IGMP_MINLEN) {
72         ++igmpstat.igps_rcv_tooshort;
73         m_freem(m);
74         return;
75     }
76     minlen = iphlen + IGMP_MINLEN;
77     if ((m->m_flags & M_EXT || m->m_len < minlen) &&
78         (m = m_pullup(m, minlen)) == 0) {
79         ++igmpstat.igps_rcv_tooshort;
80         return;
81     }
82     /*
83      * Validate checksum
84      */
85     m->m_data += iphlen;
86     m->m_len -= iphlen;
87     igmp = mtod(m, struct igmp *);
88     if (in_cksum(m, igmplen)) {
89         ++igmpstat.igps_rcv_badsum;
90         m_freem(m);
91         return;
92     }
93     m->m_data -= iphlen;
94     m->m_len += iphlen;
95     ip = mtod(m, struct ip *);

96     switch (igmp->igmp_type) {

/* switch cases */

157     }

```

97

```

158  /*
159  * Pass all valid IGMP packets up to any process(es) listening
160  * on a raw IGMP socket.
161  */
162  rip_input(m);
163  }

```

igmp.c

Figure 13.16 igmp\_input function.

```

97  case IGMP_HOST_MEMBERSHIP_QUERY:
98      ++igmpstat.igps_rcv_queries;
99
100     if (ifp == &loif)
101         break;
102
103     if (ip->ip_dst.s_addr != igmp_all_hosts_group) {
104         ++igmpstat.igps_rcv_badqueries;
105         m_freem(m);
106         return;
107     }
108     /*
109     * Start the timers in all of our membership records for
110     * the interface on which the query arrived, except those
111     * that are already running and those that belong to the
112     * "all-hosts" group.
113     */
114     IN_FIRST_MULTI(step, inm);
115     while (inm != NULL) {
116         if (inm->inm_ifp == ifp && inm->inm_timer == 0 &&
117             inm->inm_addr.s_addr != igmp_all_hosts_group) {
118             inm->inm_timer =
119                 IGMP_RANDOM_DELAY(inm->inm_addr);
120             igmp_timers_are_running = 1;
121         }
122         IN_NEXT_MULTI(step, inm);
123     }
124     break;

```

igmp.c

Figure 13.17 Input processing of the IGMP query message.

97-122 Queries that arrive on the loopback interface are silently discarded (Exercise 13.1). Queries by definition are sent to the all-hosts group. If a query arrives addressed to a different address, it is counted in `igps_rcv_badqueries` and discarded.

The receipt of a query message does not trigger an immediate flurry of IGMP membership reports. Instead, `igmp_input` resets the membership timers for each group associated with the interface on which the query was received to a random value with `IGMP_RANDOM_DELAY`. When the timer for a group expires, `igmp_fasttimo` sends a membership report. Meanwhile, the same activity is occurring on all the other hosts that received the IGMP query. As soon as the random timer for a particular group expires on one host, it is multicast to that group. This report cancels the timers on the

other hosts so that only one report is multicast to the network. The routers, as well as any other members of the group, receive the report.

The one exception to this scenario is the all-hosts group. A timer is never set for this group and a report is never sent.

#### Membership Report: IGMP\_HOST\_MEMBERSHIP\_REPORT

The receipt of an IGMP membership report is one of the two events we mentioned in Section 13.1 that does not result in an IGMP message. The effect of the message is local to the interface on which it was received. Figure 13.18 shows the message processing.

```

123     case IGMP_HOST_MEMBERSHIP_REPORT:
124         ++igmpstat.igps_rcv_reports;

125         if (ifp == &loif)
126             break;

127         if (!IN_MULTICAST(ntohl(igmp->igmp_group.s_addr)) ||
128             igmp->igmp_group.s_addr != ip->ip_dst.s_addr) {
129             ++igmpstat.igps_rcv_badreports;
130             m_freem(m);
131             return;
132         }
133         /*
134          * KLUDGE: if the IP source address of the report has an
135          * unspecified (i.e., zero) subnet number, as is allowed for
136          * a booting host, replace it with the correct subnet number
137          * so that a process-level multicast routing demon can
138          * determine which subnet it arrived from. This is necessary
139          * to compensate for the lack of any way for a process to
140          * determine the arrival interface of an incoming packet.
141          */
142         if ((ntohl(ip->ip_src.s_addr) & IN_CLASSA_NET) == 0) {
143             IFP_TO_IA(ifp, ia);
144             if (ia)
145                 ip->ip_src.s_addr = htonl(ia->ia_subnet);
146         }
147         /*
148          * If we belong to the group being reported, stop
149          * our timer for that group.
150          */
151         IN_LOOKUP_MULTI(igmp->igmp_group, ifp, inm);
152         if (inm != NULL) {
153             inm->inm_timer = 0;
154             ++igmpstat.igps_rcv_ourreports;
155         }
156         break;

```

*igmp.c*

*igmp.c*

Figure 13.18 Input processing of the IGMP report message.

123-156 Reports sent to the loopback interface are discarded, as are membership reports sent to the incorrect multicast group. That is, the message must be addressed to the group identified within the message.

The source address of an incompletely initialized host might not include a network or host number (or both). `igmp_report` looks at the class A network portion of the address, which can only be 0 when the network and subnet portions of the address are 0. If this is the case, the source address is set to the subnet address, which includes the network ID and subnet ID, of the receiving interface. The only reason for doing this is to inform a process-level daemon of the receiving interface, which is identified by the subnet number.

If the receiving interface belongs to the group being reported, the associated report timer is reset to 0. In this way the first report sent to the group stops any other hosts from issuing a report. It is only necessary for the router to know that at least one interface on the network is a member of the group. The router does not need to maintain an explicit membership list or even a counter.

### 13.8 Leaving a Group: `igmp_leavegroup` Function

We saw in Chapter 12 that `in_delmulti` calls `igmp_leavegroup` when the last reference count in the associated `in_multi` structure drops to 0.

```
179 void  
180 igmp_leavegroup(inm) igmp.c  
181 struct in_multi *inm;  
182 {  
183     /*  
184     * No action required on leaving a group.  
185     */  
186 }
```

Figure 13.19 `igmp_leavegroup` function. igmp.c

179-186 As we can see, IGMP takes no action when an interface leaves a group. No explicit notification is sent—the next time a multicast router issues an IGMP query, the interface does not generate an IGMP report for this group. If no report is generated for a group, the multicast router assumes that all the interfaces have left the group and stops forwarding multicast packets for the group to the network.

If the interface leaves the group while a report is pending (i.e., the group's report timer is running), the report is never sent, since the timer is discarded by `in_delmulti` (Figure 12.36) along with the `in_multi` structure for the group when `igmp_leavegroup` returns.

## 13.9 Summary

In this chapter we described IGMP, which communicates IP multicast membership information between hosts and routers on a single network. IGMP membership reports are generated when an interface joins a group, and on demand when multicast routers issue an IGMP report query message.

The design of IGMP minimizes the number of messages required to communicate membership information:

- Hosts announce their membership when they join a group.
- Response to membership queries are delayed for a random interval, and the first response suppresses any others.
- Hosts are silent when they leave a group.
- Membership queries are sent no more than once per minute.

Multicast routers share the IGMP information they collect with each other (Chapter 14) to route multicast datagrams toward remote members of the multicast destination group.

## Exercises

- 13.1 Why isn't it necessary to respond to an IGMP query on the loopback interface?
- 13.2 Verify the assumption stated on lines 226 to 229 in Figure 13.15.
- 13.3 Is it necessary to set random delays for membership queries that arrive on a point-to-point network interface?

14.



r 13

ship  
orts  
iters

cate

first

r 14)  
ation

-point

# 14

## IP Multicast Routing

### 14.1 Introduction

The previous two chapters discussed multicasting on a single network. In this chapter we look at multicasting across an entire internet. We describe the operation of the `mrouterd` program, which computes the multicast routing tables, and the kernel functions that forward multicast datagrams between networks.

Technically, multicast *packets* are forwarded. In this chapter we assume that every multicast packet contains an entire datagram (i.e., there are no fragments), so we use the term *datagram* exclusively. Net/3 forwards IP fragments as well as IP datagrams.

Figure 14.1 shows several versions of `mrouterd` and how they correspond to the BSD releases. The `mrouterd` releases include both the user-level daemons and the kernel-level multicast code.

mrouterd version	Description
1.2	modifies the 4.3BSD Tahoe release
2.0	included with 4.4BSD and Net/3
3.3	modifies SunOS 4.1.3

Figure 14.1 `mrouterd` and IP multicasting releases.

IP multicast technology is an active area of research and development. This chapter discusses version 2.0 of the multicast software, which is included in Net/3 but is considered an obsolete implementation. Version 3.3 was released too late to be discussed fully in this text, but we will point out various 3.3 features along the way.

Because commercial multicast routers are not widely deployed, multicast networks are often constructed using multicast *tunnels*, which connect two multicast routers over a standard IP unicast internet. Multicast tunnels are supported by Net/3 and are constructed with the Loose Source Record Route (LSRR) option (Section 9.6). An improved tunneling technique encapsulates the IP multicast datagram within an IP unicast datagram and is supported by version 3.3 of the multicast code but is not supported by Net/3.

As in Chapter 12, we use the generic term *transport protocols* to refer to the protocols that send and receive multicast datagrams, but UDP is the only Internet protocol that supports multicasting.

## 14.2 Code Introduction

The three files listed in Figure 14.2 are discussed in this chapter.

File	Description
netinet/ip_mroute.h	multicast structure definitions
netinet/ip_mroute.c	multicast routing functions
netinet/raw_ip.c	multicast routing options

Figure 14.2 Files discussed in this chapter.

### Global Variables

The global variables used by the multicast routing code are shown in Figure 14.3.

Variable	Datatype	Description
cached_mrt	struct mrt	one-behind cache for multicast routing
cached_origin	u_long	multicast group for one-behind cache
cached_originmask	u_long	mask for multicast group for one-behind cache
mrtstat	struct mrtstat	multicast routing statistics
mrttable	struct mrt *[]	hash table of pointers to multicast routes
numvifs	vifi_t	number of enabled multicast interfaces
viftable	struct vif[]	array of virtual multicast interfaces

Figure 14.3 Global variables introduced in this chapter.

### Statistics

All the statistics collected by the multicast routing code are found in the `mrtstat` structure described by Figure 14.4. Figure 14.5 shows some sample output of these statistics, from the `netstat -gs` command.

works  
over  
con-  
roved  
data-  
ed by  
  
ocols  
l that

mrtstat member	Description	Used by SNMP
mrts_mrt_lookups	#multicast route lookups	
mrts_mrt_misses	#multicast route cache misses	
mrts_grp_lookups	#group address lookups	
mrts_grp_misses	#group address cache misses	
mrts_no_route	#multicast route lookup failures	
mrts_bad_tunnel	#packets with malformed tunnel options	
mrts_cant_tunnel	#packets with no room for tunnel options	

Figure 14.4 Statistics collected in this chapter.

netstat -gs output	mrtstat members
multicast routing:	
329569328 multicast route lookups	mrts_mrt_lookups
9377023 multicast route cache misses	mrts_mrt_misses
242754062 group address lookups	mrts_grp_lookups
159317788 group address cache misses	mrts_grp_misses
65648 datagrams with no route for origin	mrts_no_route
0 datagrams with malformed tunnel options	mrts_bad_tunnel
0 datagrams with no room for tunnel options	mrts_cant_tunnel

Figure 14.5 Sample IP multicast routing statistics.

These statistics are from a system with two physical interfaces and one tunnel interface. These statistics show that the multicast route is found in the cache 98% of the time. The group address cache is less effective with only a 34% hit rate. The route cache is described with Figure 14.34 and the group address cache with Figure 14.21.

### SNMP Variables

There is no standard SNMP MIB for multicast routing, but [McCloghrie and Farinacci 1994a] and [McCloghrie and Farinacci 1994b] describe some experimental MIBs for multicast routers.

## 14.3 Multicast Output Processing Revisited

In Section 12.15 we described how an interface is selected for an outgoing multicast datagram. We saw that `ip_output` is passed an explicit interface in the `ip_options` structure, or `ip_output` looks up the destination group in the routing tables and uses the interface returned in the route entry.

If, after selecting an outgoing interface, `ip_output` loops back the datagram, it is queued for input processing on the interface selected for `output` and is considered for forwarding when it is processed by `ipintr`. Figure 14.6 illustrates this process.

t struc-  
statistics,

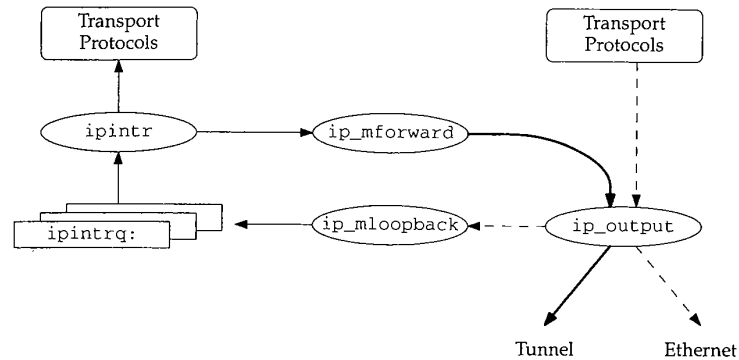

Figure 14.6 Multicast output processing with loopback.

In Figure 14.6 the dashed arrows represent the original outgoing datagram, which in this example is multicast on a local Ethernet. The copy created by `ip_mloopback` is represented by the thin arrows; this copy is passed to the transport protocols for input. The third copy is created when `ip_mforward` decides to forward the datagram through another interface on the system. The thickest arrows in Figure 14.6 represents the third copy, which in this example is sent on a multicast tunnel.

If the datagram is *not* looped back, `ip_output` passes it directly to `ip_mforward`, where it is duplicated and also processed as if it were received on the interface that `ip_output` selected. This process is shown in Figure 14.7.

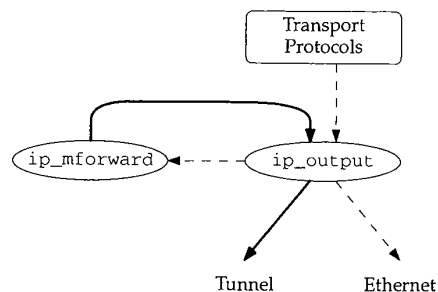

Figure 14.7 Multicast output processing with no loopback.

Whenever `ip_mforward` calls `ip_output` to send a multicast datagram, it sets the `IP_FORWARDING` flag so that `ip_output` does not pass the datagram back to `ip_mforward`, which would create an infinite loop.

`ip_mloopback` was described with Figure 12.42. `ip_mforward` is described in Section 14.8.

## 14.4 mroued Daemon

Multicast routing is enabled and managed by a user-level process: the `mroued` daemon. `mroued` implements the router portion of the IGMP protocol and communicates with other multicast routers to implement multicast routing between networks. The routing algorithms are implemented in `mroued`, but the multicast routing tables are maintained in the kernel, which forwards the datagrams.

In this text we describe only the kernel data structures and functions that support `mroued`—we do not describe `mroued` itself. We describe the Truncated Reverse Path Broadcast (TRPB) algorithm [Deering and Cheriton 1990], used to select routes for multicast datagrams, and the Distance Vector Multicast Routing Protocol (DVMRP), used to convey information between multicast routers, in enough detail to make sense of the kernel multicast code.

RFC 1075 [Waitzman, Partridge, and Deering 1988] describes an old version of DVMRP. `mroued` implements a newer version of DVMRP, which is not yet documented in an RFC. The best documentation for the current algorithm and protocol is the source code release for `mroued`. Appendix B describes where the source code can be obtained.

The `mroued` daemon communicates with the kernel by setting options on an IGMP socket (Chapter 32). The options are summarized in Figure 14.8.

optname	optval type	Function	Description
<code>DVMRP_INIT</code>		<code>ip_mrouter_init</code>	<code>mroued</code> is starting
<code>DVMRP_DONE</code>		<code>ip_mrouter_done</code>	<code>mroued</code> is shutting down
<code>DVMRP_ADD_VIF</code>	<code>struct vifctl</code>	<code>add_vif</code>	add virtual interface
<code>DVMRP_DEL_VIF</code>	<code>vifi_t</code>	<code>del_vif</code>	delete virtual interface
<code>DVMRP_ADD_LGRP</code>	<code>struct lgrpctl</code>	<code>add_lgrp</code>	add multicast group entry for an interface
<code>DVMRP_DEL_LGRP</code>	<code>struct lgrpctl</code>	<code>del_lgrp</code>	delete multicast group entry for an interface
<code>DVMRP_ADD_MRT</code>	<code>struct mrtctl</code>	<code>add_mrt</code>	add multicast route
<code>DVMRP_DEL_MRT</code>	<code>struct in_addr</code>	<code>del_mrt</code>	delete multicast route

Figure 14.8 Multicast routing socket options.

The socket options shown in Figure 14.8 are passed to `rip_ctloutput` (Section 32.8) by the `setsockopt` system call. Figure 14.9 shows the portion of `rip_ctloutput` that handles the `DVMRP_xxx` options.

173-187 When `setsockopt` is called, `op` equals `PRCO_SETOPT` and all the options are passed to the `ip_mrouter_cmd` function. For the `getsockopt` system call, `op` equals `PRCO_GETOPT` and `EINVAL` is returned for all the options.

Figure 14.10 shows the `ip_mrouter_cmd` function.

These “options” are more like commands, since they cause the kernel to update various data structures. We use the term *command* throughout the rest of this chapter to emphasize this fact.

```

173 case DVMRP_INIT:
174 case DVMRP_DONE:
175 case DVMRP_ADD_VIF:
176 case DVMRP_DEL_VIF:
177 case DVMRP_ADD_LGRP:
178 case DVMRP_DEL_LGRP:
179 case DVMRP_ADD_MRT:
180 case DVMRP_DEL_MRT:
181     if (op == PRCO_SETOPT) {
182         error = ip_mrouter_cmd(optname, so, *m);
183         if (*m)
184             (void) m_free(*m);
185     } else
186         error = EINVAL;
187     return (error);

```

*raw\_ip.c*

*raw\_ip.c*

Figure 14.9 rip\_ctloutput function: DVMRP\_xxx socket options.

```

84 int
85 ip_mrouter_cmd(cmd, so, m)
86 int cmd;
87 struct socket *so;
88 struct mbuf *m;
89 {
90     int error = 0;
91     if (cmd != DVMRP_INIT && so != ip_mrouter)
92         error = EACCES;
93     else
94         switch (cmd) {
95             case DVMRP_INIT:
96                 error = ip_mrouter_init(so);
97                 break;
98             case DVMRP_DONE:
99                 error = ip_mrouter_done();
100                break;
101             case DVMRP_ADD_VIF:
102                 if (m == NULL || m->m_len < sizeof(struct vifctl))
103                     error = EINVAL;
104                 else
105                     error = add_vif(mtod(m, struct vifctl *));
106                 break;
107             case DVMRP_DEL_VIF:
108                 if (m == NULL || m->m_len < sizeof(short))
109                     error = EINVAL;
110                 else
111                     error = del_vif(mtod(m, vifi_t *));
112                 break;

```

*ip\_mroute.c*

```

113     case DVMRP_ADD_LGRP:
114         if (m == NULL || m->m_len < sizeof(struct lgrplctl))
115             error = EINVAL;
116         else
117             error = add_lgrp(mtod(m, struct lgrplctl *));
118         break;

119     case DVMRP_DEL_LGRP:
120         if (m == NULL || m->m_len < sizeof(struct lgrplctl))
121             error = EINVAL;
122         else
123             error = del_lgrp(mtod(m, struct lgrplctl *));
124         break;

125     case DVMRP_ADD_MRT:
126         if (m == NULL || m->m_len < sizeof(struct mrtctl))
127             error = EINVAL;
128         else
129             error = add_mrt(mtod(m, struct mrtctl *));
130         break;

131     case DVMRP_DEL_MRT:
132         if (m == NULL || m->m_len < sizeof(struct in_addr))
133             error = EINVAL;
134         else
135             error = del_mrt(mtod(m, struct in_addr *));
136         break;

137     default:
138         error = EOPNOTSUPP;
139         break;
140     }
141     return (error);
142 }

```

*ip\_mroute.c*

Figure 14.10 ip\_mrouter\_cmd function.

84-92 The first command issued by mrouterd must be DVMRP\_INIT. Subsequent commands must come from the same socket as the DVMRP\_INIT command. EACCES is returned when other commands are issued on a different socket.

94-142 Each case in the switch checks to see if the right amount of data was included with the command and then calls the matching function. If the command is not recognized, EOPNOTSUPP is returned. Any error returned from the matching function is posted in error and returned at the end of the function.

Figure 14.11 shows ip\_mrouter\_init, which is called when mrouterd issues the DVMRP\_INIT command during initialization.

146-157 If the command is issued on something other than a raw IGMP socket, or if DVMRP\_INIT has already been set, EOPNOTSUPP or EADDRINUSE are returned respectively. A pointer to the socket on which the initialization command is issued is saved in the global ip\_mrouter. Subsequent commands must be issued on this socket. This prevents the concurrent operation of more than one instance of mrouterd.

```

146 static int
147 ip_mrouter_init(so)
148 struct socket *so;
149 {
150     if (so->so_type != SOCK_RAW ||
151         so->so_proto->pr_protocol != IPPROTO_IGMP)
152         return (EOPNOTSUPP);
153
154     if (ip_mrouter != NULL)
155         return (EADDRINUSE);
156
157     ip_mrouter = so;
158     return (0);
159 }

```

ip\_mroute.c

ip\_mroute.c

Figure 14.11 ip\_mrouter\_init function: DVMRP\_INIT command.

The remainder of the DVMRP\_XXX commands are described in the following sections.

## 14.5 Virtual Interfaces

When operating as a multicast router, Net/3 accepts incoming multicast datagrams, duplicates them and forwards the copies through one or more interfaces. In this way, the datagram is forwarded to other multicast routers on the internet.

An outgoing interface can be a physical interface or it can be a multicast *tunnel*. Each end of the multicast tunnel is associated with a physical interface on a multicast router. Multicast tunnels allow two multicast routers to exchange multicast datagrams even when they are separated by routers that cannot forward multicast datagrams. Figure 14.12 shows two multicast routers connected by a multicast tunnel.

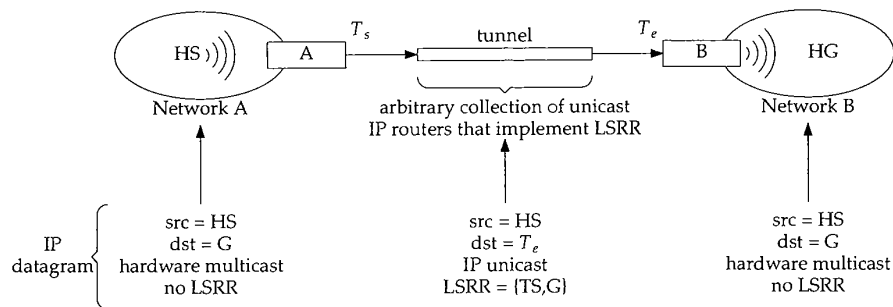

Figure 14.12 A multicast tunnel.

In Figure 14.12, the source host HS on network A is multicasting a datagram to group G. The only member of group G is on network B, which is connected to network A by a multicast tunnel. Router A receives the multicast (because multicast routers receive *all*



multicasts), consults its multicast routing tables, and forwards the datagram through the multicast tunnel.

The tunnel starts on the *physical* interface on router A identified by the IP unicast address  $T_s$ . The tunnel ends on the *physical* interface on router B identified by the IP unicast address,  $T_e$ . The tunnel itself is an arbitrarily complex collection of networks connected by IP unicast routers that implement the LSRR option. Figure 14.13 shows how an IP LSRR option implements the multicast tunnel.

System	IP header		Source route option		Description
	ip_src	ip_dst	offset	addresses	
HS	HS	G			on network A
$T_s$	HS	$T_e$	8	$T_s \bullet G$	on tunnel
$T_e$	HS	G	12	$T_s$ see text $\bullet$	after ip_dooptions on router B
$T_e$	HS	G			after ip_mforward on router B

Figure 14.13 LSRR multicast tunnel options.

The first line of Figure 14.13 shows the datagram sent by HS as a multicast on network A. Router A receives the datagram because multicast routers receive all multicasts on their locally attached networks.

To send the datagram through the tunnel, router A inserts an LSRR option in the IP header. The second line shows the datagram as it leaves A on the tunnel. The first address in the LSRR option is the source address of the tunnel and the second address is the destination group. The destination of the datagram is  $T_e$ —the other end of the tunnel. The LSRR offset points to the *destination group*.

The tunneled datagram is forwarded through the internet until it reaches the other end of the tunnel on router B.

The third line of the figure shows the datagram after it is processed by `ip_dooptions` on router B. Recall from Chapter 9 that `ip_dooptions` processes the LSRR option before the destination address of the datagram is examined by `ipintr`. Since the destination address of the datagram ( $T_e$ ) matches one of the interfaces on router B, `ip_dooptions` copies the address identified by the option offset (G in this example) into the destination field of the IP header. In the option, G is replaced with the address returned by `ip_rtaddr`, which normally selects the outgoing interface for the datagram based on the IP destination address (G in this case). This address is irrelevant, since `ip_mforward` discards the entire option. Finally, `ip_dooptions` advances the option offset.

The fourth line in Figure 14.13 shows the datagram after `ipintr` calls `ip_mforward`, where the LSRR option is recognized and removed from the datagram header. The resulting datagram looks like the original multicast datagram and is processed by `ip_mforward`, which in our example forwards it onto network B as a multicast datagram where it is received by HG.

Multicast tunnels constructed with LSRR options are obsolete. Since the March 1993 release of `mouted`, tunnels have been constructed by prepending another IP header to the IP multicast datagram. The protocol in the new IP header is set to 4 to indicate that the contents of the packet is another IP packet. This value is documented

in RFC 1700 as the "IP in IP" protocol. LSRR tunnels are supported in newer versions of mroute for backward compatibility.

### Virtual Interface Table

For both physical interfaces and tunnel interfaces, the kernel maintains an entry in a *virtual interface* table, which contains information that is used only for multicasting. Each virtual interface is described by a *vif* structure (Figure 14.14). The global variable *viftable* is an array of these structures. An index to the table is stored in a *vifi\_t* variable, which is an unsigned short integer.

```

105 struct vif {
106     u_char  v_flags;           /* VIFF_ flags */
107     u_char  v_threshold;      /* min ttl required to forward on vif */
108     struct in_addr v_lcl_addr; /* local interface address */
109     struct in_addr v_rmt_addr; /* remote address (tunnels only) */
110     struct ifnet *v_ifp;      /* pointer to interface */
111     struct in_addr *v_lcl_grps; /* list of local grps (phyints only) */
112     int      v_lcl_grps_max;   /* malloc'ed number of v_lcl_grps */
113     int      v_lcl_grps_n;    /* used number of v_lcl_grps */
114     u_long   v_cached_group;   /* last grp looked-up (phyints only) */
115     int      v_cached_result;  /* last look-up result (phyints only) */
116 };

```

ip\_mroute.h

ip\_mroute.h

Figure 14.14 vif structure.

105-110 The only flag defined for *v\_flags* is *VIFF\_TUNNEL*. When set, the interface is a tunnel to a remote multicast router. When not set, the interface is a physical interface on the local system. *v\_threshold* is the multicast threshold, which we described in Section 12.9. *v\_lcl\_addr* is the unicast IP address of the local interface associated with this virtual interface. *v\_rmt\_addr* is the unicast IP address of the remote end of an IP multicast tunnel. Either *v\_lcl\_addr* or *v\_rmt\_addr* is nonzero, but never both. For physical interfaces, *v\_ifp* is nonnull and points to the *ifnet* structure of the local interface. For tunnels, *v\_ifp* is null.

111-116 The list of groups with members on the attached interface is kept as an array of IP multicast group addresses pointed to by *v\_lcl\_grps*, which is always null for tunnels. The size of the array is in *v\_lcl\_grps\_max*, and the number of entries that are used is in *v\_lcl\_grps\_n*. The array grows as needed to accommodate the group membership list. *v\_cached\_group* and *v\_cached\_result* implement a one-entry cache, which contain the group and result of the previous lookup.

Figure 14.15 illustrates the *viftable*, which has 32 (*MAXVIFS*) entries. *viftable[2]* is the last entry in use, so *numvifs* is 3. The size of the table is fixed when the kernel is compiled. Several members of the *vif* structure in the first entry of the table are shown. *v\_ifp* points to an *ifnet* structure, *v\_lcl\_grps* points to an array of *in\_addr* structures. The array has 32 (*v\_lcl\_grps\_max*) entries, of which only 4 (*v\_lcl\_grps\_n*) are in use.

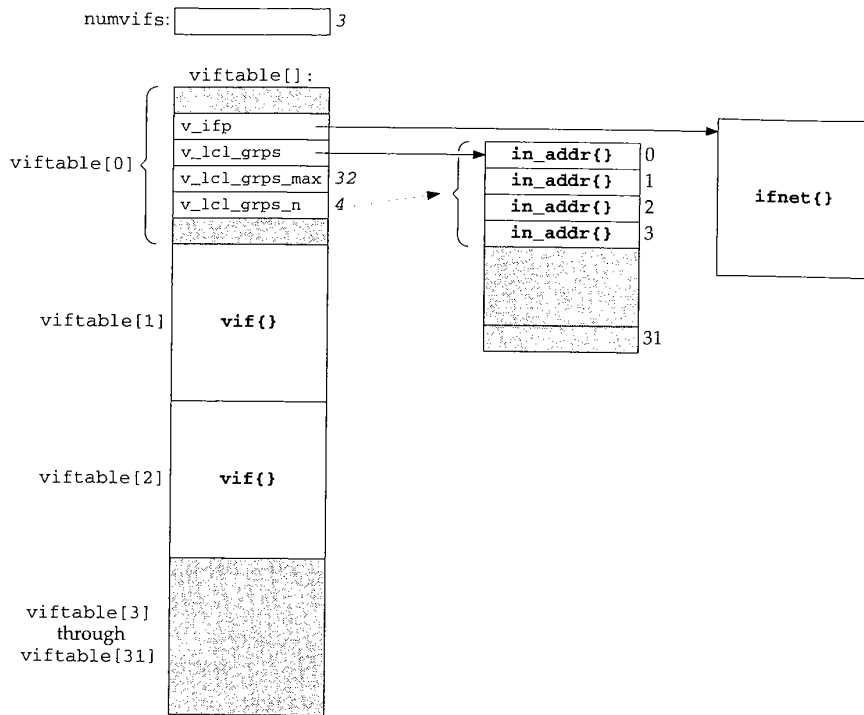

Figure 14.15 viftable array.

mrouterd maintains viftable through the DVMRP\_ADD\_VIF and DVMRP\_DEL\_VIF commands. Normally all multicast-capable interfaces on the local system are added to the table when mrouterd begins. Multicast tunnels are added when mrouterd reads its configuration file, usually /etc/mrouterd.conf. Commands in this file can also delete physical interfaces from the virtual interface table or change the multicast information associated with the interfaces.

A vifctl structure (Figure 14.16) is passed by mrouterd to the kernel with the DVMRP\_ADD\_VIF command. It instructs the kernel to add an interface to the table of virtual interfaces.

```

76 struct vifctl {
77     vifi_t vifc_vifi;          /* the index of the vif to be added */
78     u_char vifc_flags;        /* VIFF_ flags (Figure 14.14) */
79     u_char vifc_threshold;    /* min ttl required to forward on vif */
80     struct in_addr vifc_lcl_addr; /* local interface address */
81     struct in_addr vifc_rmt_addr; /* remote address (tunnels only) */
82 };

```

ip\_mroute.h

Figure 14.16 vifctl structure.

76-82 vifc\_vifi identifies the index of the virtual interface within viftable. The remaining four members, vifc\_flags, vifc\_threshold, vifc\_lcl\_addr, and vifc\_rmt\_addr, are copied into the vif structure by the add\_vif function.

### add\_vif Function

Figure 14.17 shows the add\_vif function.

```

202 static int
203 add_vif(vifcp)
204 struct vifctl *vifcp;
205 {
206     struct vif *vifp = viftable + vifcp->vifc_vifi;
207     struct ifaddr *ifa;
208     struct ifnet *ifp;
209     struct ifreq ifr;
210     int error, s;
211     static struct sockaddr_in sin =
212     {sizeof(sin), AF_INET};
213
214     if (vifcp->vifc_vifi >= MAXVIFS)
215         return (EINVAL);
216     if (vifcp->v_lcl_addr.s_addr != 0)
217         return (EADDRINUSE);
218
219     /* Find the interface with an address in AF_INET family */
220     sin.sin_addr = vifcp->vifc_lcl_addr;
221     ifa = ifa_ifwithaddr((struct sockaddr *) &sin);
222     if (ifa == 0)
223         return (EADDRNOTAVAIL);
224
225     s = splnet();
226
227     if (vifcp->vifc_flags & VIFF_TUNNEL)
228         vifcp->v_rmt_addr = vifcp->vifc_rmt_addr;
229     else {
230         /* Make sure the interface supports multicast */
231         ifp = ifa->ifa_ifp;
232         if ((ifp->if_flags & IFF_MULTICAST) == 0) {
233             splx(s);
234             return (EOPNOTSUPP);
235         }
236         /*
237          * Enable promiscuous reception of all IP multicasts
238          * from the interface.
239          */
240         satosin(&ifr.ifr_addr)->sin_family = AF_INET;
241         satosin(&ifr.ifr_addr)->sin_addr.s_addr = INADDR_ANY;
242         error = (*ifp->if_ioctl) (ifp, SIOCADDMULTI, (caddr_t) &ifr);
243         if (error) {
244             splx(s);
245             return (error);
246         }
247     }
248 }

```

*ip\_mroute.c*

he  
nd

e.c

```

244     vifp->v_flags = vifcp->vifc_flags;
245     vifp->v_threshold = vifcp->vifc_threshold;
246     vifp->v_lcl_addr = vifcp->vifc_lcl_addr;
247     vifp->v_ifp = ifa->ifa_ifp;

248     /* Adjust numvifs up if the vifi is higher than numvifs */
249     if (numvifs <= vifcp->vifc_vifi)
250         numvifs = vifcp->vifc_vifi + 1;

251     splx(s);
252     return (0);
253 }

```

*ip\_mroute.c***Figure 14.17** add\_vif function: DVMRP\_ADD\_VIF command.**Validate index**

202-216 If the table index specified by mroute in `vifc_vifi` is too large, or the table entry is already in use, `EINVAL` or `EADDRINUSE` is returned respectively.

**Locate physical interface**

217-221 `ifa_ifwithaddr` takes the unicast IP address in `vifc_lcl_addr` and returns a pointer to the associated `ifnet` structure. This identifies the physical interface to be used for this virtual interface. If there is no matching interface, `EADDRNOTAVAIL` is returned.

**Configure tunnel interface**

222-224 For a tunnel, the remote end of the tunnel is copied from the `vifctl` structure to the `vif` structure in the interface table.

**Configure physical interface**

225-243 For a physical interface, the link-level driver must support multicasting. The `SIOCADMULTI` command used with `INADDR_ANY` configures the interface to begin receiving *all* IP multicast datagrams (Figure 12.32) because it is a multicast router. Incoming datagrams are forwarded when `ipintr` passes them to `ip_mforward`.

**Save multicast information**

244-253 The remaining interface information is copied from the `vifctl` structure to the `vif` structure. If necessary, `numvifs` is updated to record the number of virtual interfaces in use.

**del\_vif Function**

The function `del_vif`, shown in Figure 14.18, deletes entries from the virtual interface table. It is called when mroute sets the `DVMRP_DEL_VIF` command.

**Validate index**

257-268 If the index passed to `del_vif` is greater than the largest index in use or it references an entry that is not in use, `EINVAL` or `EADDRNOTAVAIL` is returned respectively.

```

257 static int
258 del_vif(vifip)
259 vifi_t *vifip;
260 {
261     struct vif *vifp = viftable + *vifip;
262     struct ifnet *ifp;
263     int i, s;
264     struct ifreq ifr;

265     if (*vifip >= numvifs)
266         return (EINVAL);
267     if (vifp->v_lcl_addr.s_addr == 0)
268         return (EADDRNOTAVAIL);

269     s = splnet();

270     if (!(vifp->v_flags & VIFF_TUNNEL)) {
271         if (vifp->v_lcl_grps)
272             free(vifp->v_lcl_grps, M_MRTABLE);
273         satosin(&ifr.ifr_addr)->sin_family = AF_INET;
274         satosin(&ifr.ifr_addr)->sin_addr.s_addr = INADDR_ANY;
275         ifp = vifp->v_ifp;
276         (*ifp->if_ioctl) (ifp, SIOCDELMULTI, (caddr_t) &ifr);
277     }
278     bzero((caddr_t) vifp, sizeof(*vifp));

279     /* Adjust numvifs down */
280     for (i = numvifs - 1; i >= 0; i--)
281         if (viftable[i].v_lcl_addr.s_addr != 0)
282             break;
283     numvifs = i + 1;

284     splx(s);
285     return (0);
286 }

```

Figure 14.18 del\_vif function: DVMRP\_DEL\_VIF command.

#### Delete interface

269-278 For a physical interface, the local group table is released, and the reception of all multicast datagrams is disabled by SIOCDELMULTI. The entry in viftable is cleared by bzero.

#### Adjust interface count

279-286 The for loop searches for the first active entry in the table starting at the largest previously active entry and working back toward the first entry. For unused entries, the s\_addr member of v\_lcl\_addr (an in\_addr structure) is 0. numvifs is updated accordingly and the function returns.

add\_:

291-30

302-32

## 14.6 IGMP Revisited

Chapter 13 focused on the host part of the IGMP protocol. `mrouterd` implements the router portion of this protocol. For every physical interface, `mrouterd` must keep track of which multicast groups have members on the attached network. `mrouterd` multicasts an `IGMP_HOST_MEMBERSHIP_QUERY` datagram every 120 seconds and compiles the resulting `IGMP_HOST_MEMBERSHIP_REPORT` datagrams into a membership array associated with each network. This array is *not* the same as the membership list we described in Chapter 13.

From the information collected, `mrouterd` constructs the multicast routing tables. The list of groups is also used to suppress multicasts to areas of the multicast internet that do not have members of the destination group.

The membership array is maintained only for physical interfaces. Tunnels are point-to-point interfaces to another multicast router, so no group membership information is needed.

We saw in Figure 14.14 that `v_lcl_grps` points to an array of IP multicast groups. `mrouterd` maintains this list with the `DVMRP_ADD_LGRP` and `DVMRP_DEL_LGRP` commands. An `lgrplctl` (Figure 14.19) structure is passed with both commands.

```

87 struct lgrplctl {                                     ip_mroute.h
88     vifi_t  lgc_vifi;
89     struct in_addr lgc_gaddr;
90 };

```

Figure 14.19 `lgrplctl` structure.

<sup>87-90</sup> The {interface, group} pair is identified by `lgc_vifi` and `lgc_gaddr`. The interface index (`lgc_vifi`, an unsigned short) identifies a *virtual* interface, not a physical interface.

When an `IGMP_HOST_MEMBERSHIP_REPORT` datagram is received, the functions shown in Figure 14.20 are called.

### `add_lgrp` Function

`mrouterd` examines the source address of an incoming IGMP report to determine which subnet and therefore which interface the report arrived on. Based on this information, `mrouterd` sets the `DVMRP_ADD_LGRP` command for the interface to update the membership table in the kernel. This information is also fed into the multicast routing algorithm to update the routing tables. Figure 14.21 shows the `add_lgrp` function.

#### Validate add request

<sup>291-301</sup> If the request identifies an invalid interface, `EINVAL` is returned. If the interface is not in use or is a tunnel, `EADDRNOTAVAIL` is returned.

#### If needed, expand group array

<sup>302-326</sup> If the new group won't fit in the current group array, a new array is allocated. The first time `add_lgrp` is called for an interface, an array is allocated to hold 32 groups.

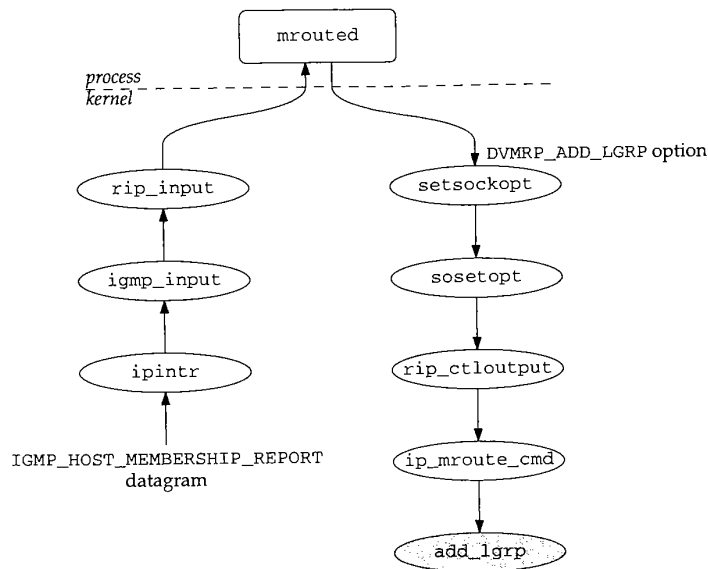

Figure 14.20 IGMP report processing.

Each time the array fills, `add_lgrp` allocates a new array of twice the previous size. The new array is allocated by `malloc`, cleared by `bzero`, and filled by copying the old array into the new one with `bcopy`. The maximum number of entries, `v_lcl_grps_max`, is updated, the old array (if any) is released, and the new array is attached to the `vif` entry with `v_lcl_grps`.

The “paranoid” comment points out there is no guarantee that the memory allocated by `malloc` contains all 0s.

#### Add new group

327–332 The new group is copied into the next available entry and if the cache already contains the new group, the cache is marked as valid.

The lookup cache contains an address, `v_cached_group`, and a cached lookup result, `v_cached_result`. The `grplst_member` function always consults the cache before searching the membership array. If the given group matches `v_cached_group`, the cached result is returned; otherwise the membership array is searched.

#### del\_lgrp Function

Group information is expired for each interface when no membership report has been received for the group within 270 seconds. `mrouded` maintains the appropriate timers and issues the `DVMRP_DEL_LGRP` command when the information expires. Figure 14.22 shows `del_lgrp`.



```

291 static int
292 add_lgrp(gcp)
293 struct lgrplctl *gcp;
294 {
295     struct vif *vifp;
296     int s;
297
298     if (gcp->lgc_vifi >= numvifs)
299         return (EINVAL);
300
301     vifp = viftable + gcp->lgc_vifi;
302     if (vifp->v_lcl_addr.s_addr == 0 || (vifp->v_flags & VIF_TUNNEL))
303         return (EADDRNOTAVAIL);
304
305     /* If not enough space in existing list, allocate a larger one */
306     s = splnet();
307     if (vifp->v_lcl_grps_n + 1 >= vifp->v_lcl_grps_max) {
308         int num;
309         struct in_addr *ip;
310
311         num = vifp->v_lcl_grps_max;
312         if (num <= 0)
313             num = 32; /* initial number */
314         else
315             num += num; /* double last number */
316         ip = (struct in_addr *) malloc(num * sizeof(*ip),
317                                     M_MRTABLE, M_NOWAIT);
318         if (ip == NULL) {
319             splx(s);
320             return (ENOBUFS);
321         }
322         bzero((caddr_t) ip, num * sizeof(*ip)); /* XXX paranoid */
323         bcopy((caddr_t) vifp->v_lcl_grps, (caddr_t) ip,
324              vifp->v_lcl_grps_n * sizeof(*ip));
325
326         vifp->v_lcl_grps_max = num;
327         if (vifp->v_lcl_grps)
328             free(vifp->v_lcl_grps, M_MRTABLE);
329         vifp->v_lcl_grps = ip;
330
331         splx(s);
332     }

```

Figure 14.21 add\_lgrp function: process DVMRP\_ADD\_LGRP command.

```

337 static int
338 del_lgrp(gcp)
339 struct lgrpctl *gcp;
340 {
341     struct vif *vifp;
342     int    i, error, s;

343     if (gcp->lgc_vifi >= numvifs)
344         return (EINVAL);
345     vifp = viftable + gcp->lgc_vifi;
346     if (vifp->v_lcl_addr.s_addr == 0 || (vifp->v_flags & VIFF_TUNNEL))
347         return (EADDRNOTAVAIL);

348     s = splnet();

349     if (gcp->lgc_gaddr.s_addr == vifp->v_cached_group)
350         vifp->v_cached_result = 0;

351     error = EADDRNOTAVAIL;
352     for (i = 0; i < vifp->v_lcl_grps_n; ++i)
353         if (same(&gcp->lgc_gaddr, &vifp->v_lcl_grps[i])) {
354             error = 0;
355             vifp->v_lcl_grps_n--;
356             bcopy((caddr_t) &vifp->v_lcl_grps[i + 1],
357                 (caddr_t) &vifp->v_lcl_grps[i],
358                 (vifp->v_lcl_grps_n - i) * sizeof(struct in_addr));
359             error = 0;
360             break;
361         }
362     splx(s);
363     return (error);
364 }

```

*ip\_mroute.c*

*ip\_mroute.c*

Figure 14.22 del\_lgrp function: process DVMRP\_DEL\_LGRP command.

#### Validate interface index

337-347 If the request identifies an invalid interface, `EINVAL` is returned. If the interface is not in use or is a tunnel, `EADDRNOTAVAIL` is returned.

#### Update lookup cache

348-350 If the group to be deleted is in the cache, the lookup result is set to 0 (false).

#### Delete group

351-364 `EADDRNOTAVAIL` is posted in `error` in case the group is not found in the membership list. The `for` loop searches the membership array associated with the interface. If `same` (a macro that uses `bcmp` to compare the two addresses) is true, `error` is cleared and the group count is decremented. `bcopy` shifts the subsequent array entries down to delete the group and `del_lgrp` breaks out of the loop.

If the loop completes without finding a match, `EADDRNOTAVAIL` is returned; otherwise 0 is returned.

route.c

**grplst\_member Function**

During multicast forwarding, the membership array is consulted to avoid sending datagrams on a network when no member of the destination group is present. `grplst_member`, shown in Figure 14.23, searches the list looking for the given group address.

```

368 static int                                     ip_mroute.c
369 grplst_member(vifp, gaddr)
370 struct vif *vifp;
371 struct in_addr gaddr;
372 {
373     int    i, s;
374     u_long  addr;

375     mrtstat.mrts_grp_lookups++;

376     addr = gaddr.s_addr;
377     if (addr == vifp->v_cached_group)
378         return (vifp->v_cached_result);

379     mrtstat.mrts_grp_misses++;

380     for (i = 0; i < vifp->v_lcl_grps_n; ++i)
381         if (addr == vifp->v_lcl_grps[i].s_addr) {
382             s = splnet();
383             vifp->v_cached_group = addr;
384             vifp->v_cached_result = 1;
385             splx(s);
386             return (1);
387         }
388     s = splnet();
389     vifp->v_cached_group = addr;
390     vifp->v_cached_result = 0;
391     splx(s);
392     return (0);
393 }

```

route.c

ace is

Figure 14.23 `grplst_member` function.**Check the cache**

368-379 If the requested group is located in the cache, the cached result is returned and the membership array is not searched.

**Search the membership array**

380-393 A linear search determines if the group is in the array. If it is found, the cache is updated to record the match and one is returned. If it is not found, the cache is updated to record the miss and 0 is returned.

member-  
ice. If  
eared  
down  
other-

## 14.7 Multicast Routing

As we mentioned at the start of this chapter, we will not be presenting the TRPB algorithm implemented by `mroute`, but we do need to provide a general overview of the mechanism to describe the multicast routing table and the multicast routing functions in the kernel. Figure 14.24 shows the sample multicast network that we use to illustrate the algorithms.

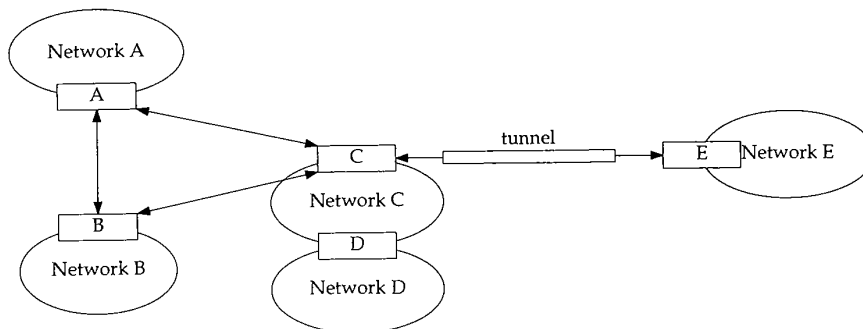

Figure 14.24 Sample multicast network.

In Figure 14.24, routers are shown as boxes and the ellipses are the multicast networks attached to the routers. For example, router D can multicast on network D and C. Router C can multicast to network C, to routers A and B through point-to-point interfaces, and to E through a multicast tunnel.

The simplest approach to multicast routing is to select a subset of the internet topology that forms a *spanning tree*. If each router forwards multicasts along the spanning tree, every router eventually receives the datagram. Figure 14.25 shows one spanning tree for our sample network, where host S on network A represents the source of a multicast datagram.

For a discussion of spanning trees, see [Tanenbaum 1989] or [Perman 1992].

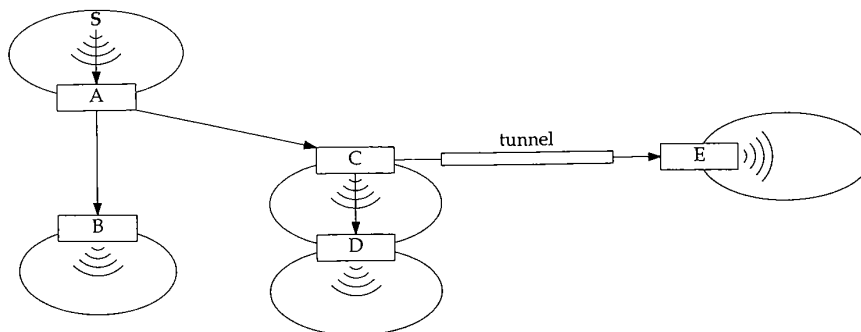

Figure 14.25 Spanning tree for network A.

We constructed the tree based on the shortest *reverse path* from every network back to the source in network A. In Figure 14.25, the link between routers B and C is omitted to form the spanning tree. The arrows between the source and router A, and between router C and D, emphasize that the multicast network is part of the spanning tree.

If the same spanning tree were used to forward a datagram from network C, the datagram would be forwarded along a longer path than needed to get to a recipient on network B. The algorithm described in RFC 1075 computes a separate spanning tree for each potential source network to avoid this problem. The routing tables contain a network number and subnet mask for each route, so that a single route applies to any host within the source subnet.

Because each spanning tree is constructed to provide the shortest reverse path to the source of the datagram, and every network receives every multicast datagram, this process is called *reverse path broadcasting* or RPB.

The RPB protocol has no knowledge of multicast group membership, so many datagrams are unnecessarily forwarded to networks that have no members in the destination group. If, in addition to computing the spanning trees, the routing algorithm records which networks are *leaves* and is aware of the group membership on each network, then routers attached to leaf networks can avoid forwarding datagrams onto the network when there is no member of the destination group present. This is called *truncated reverse path broadcasting* (TRPB), and is implemented by version 2.0 of mroute with the help of IGMP to keep track of membership in the leaf networks.

Figure 14.26 shows TRPB applied to a multicast sent from a source on network C and with a member of the destination group on network B.

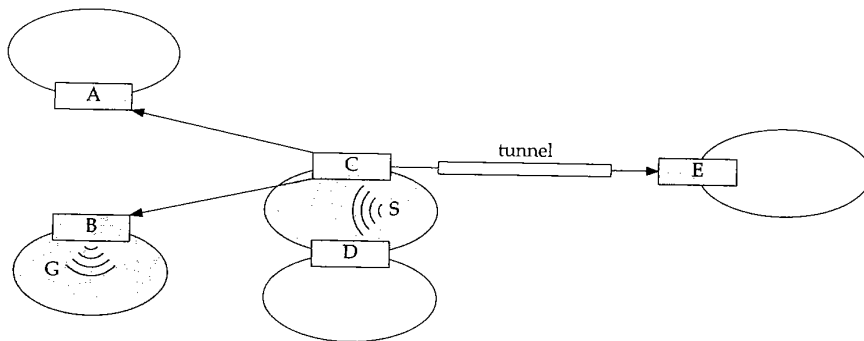

Figure 14.26 TRPB routing for network C.

We'll use Figure 14.26 to illustrate the terms used in the Net/3 multicast routing table. In this example, the shaded networks and routers receive a copy of the multicast datagram sent from the source on network C. The link between A and B is not part of the spanning tree and C does not have a link to D, since the multicast sent by the source is received directly by C and D.

In this figure, networks A, B, D, and E are leaf networks. Router C receives the multicast and forwards it through the interfaces attached to routers A, B, and E—even

though sending it to A and E is wasted effort. This is a major weakness of the TRPB algorithm.

The interface associated with network C on router C is called the *parent* because it is the interface on which router C expects to receive multicasts originating from network C. The interfaces from router C to routers A, B, and E, are *child* interfaces. For router A, the point-to-point interface is the parent for the source packets from C and the interface for network A is a child. Interfaces are identified as a parent or as a child relative to the source of the datagram. Multicast datagrams are forwarded only to the associated child interfaces, and never to the parent interface.

Continuing with the example, networks A, D, and E are not shaded because they are leaf networks without members of the destination group, so the spanning tree is truncated at the routers and the datagram is not forwarded onto these networks. Router B forwards the datagram onto network B, since there is a member of the destination group on the network. To implement the truncation algorithm, each multicast router that receives the datagram consults the group table associated with every virtual interface in the router's *vif* table.

The final refinement to the multicast routing algorithm is called *reverse path multicasting* (RPM). The goal of RPM is to *prune* each spanning tree and avoid sending datagrams along branches of the tree that do not contain a member of the destination group. In Figure 14.26, RPM would prevent router C from sending a datagram to A and E, since there is no member of the destination group in those branches of the tree. Version 3.3 of *mrouterd* implements RPM.

Figure 14.27 shows our example network, but this time only the routers and networks reached when the datagram is routed by RPM are shaded.

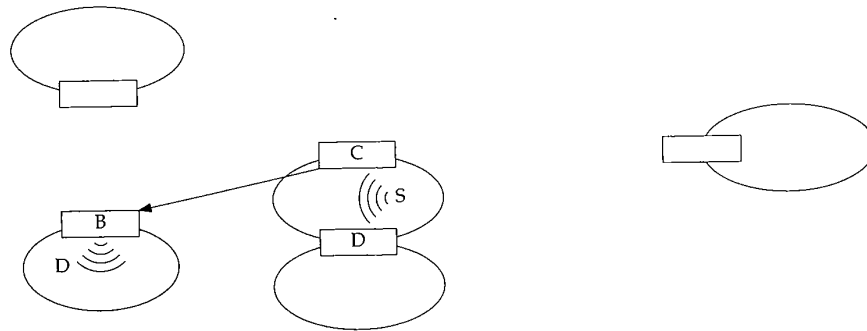

Figure 14.27 RPM routing for network C.

To compute the routing tables corresponding to the spanning trees we described, the multicast routers communicate with adjacent multicast routers to discover the multicast internet topology and the location of multicast group members. In *Net/3*, DVMRP is used for this communication. DVMRP messages are transmitted as IGMP datagrams and are sent to the multicast group 224.0.0.4, which is reserved for DVMRP communication (Figure 12.1).

In Figure 12.39, we saw that incoming IGMP packets are always accepted by a

PB

: is

rk

A,

ice

.he

ild

ey

: is

ks.

na-

ast

ual

ath

ing

ion

und

ree.

ret-

multicast router. They are passed to `igmp_input`, to `rip_input`, and then read by `mROUTED` on a raw IGMP socket. `mROUTED` sends DVMRP messages to other multicast routers on the same raw IGMP socket.

For more information about RPB, TRPB, RPM, and the DVMRP messages that are needed to implement these algorithms, see [Deering and Cheriton 1990] and the source code release of `mROUTED`.

There are other multicast routing protocols in use on the Internet. Proteon routers implement the MOSPF protocol described in RFC 1584 [Moy 1994]. PIM (Protocol Independent Multicasting) is implemented by Cisco routers, starting with Release 10.2 of their operating software. PIM is described in [Deering et al. 1994].

### Multicast Routing Table

We can now describe the implementation of the multicast routing tables in Net/3. The kernel's multicast routing table is maintained as a hash table with 64 entries (MRTHASHSZ). The table is kept in the global array `mrttable`, and each entry points to a linked list of `mrt` structures, shown in Figure 14.28.

```

120 struct mrt {
121     struct in_addr mrt_origin; /* subnet origin of multicasts */
122     struct in_addr mrt_originmask; /* subnet mask for origin */
123     vifi_t mrt_parent; /* incoming vif */
124     vifbitmap_t mrt_children; /* outgoing children vifs */
125     vifbitmap_t mrt_leaves; /* subset of outgoing children vifs */
126     struct mrt *mrt_next; /* forward link */
127 };

```

ip\_mroute.h

Figure 14.28 mrt structure.

`mrtc_origin` and `mrtc_originmask` identify an entry in the table. `mrtc_parent` is the index of the virtual interface on which all multicast datagrams from the origin are expected. The outgoing interfaces are identified within `mrtc_children`, which is a bitmap. Outgoing interfaces that are also leaves in the multicast routing tree are identified in `mrtc_leaves`, which is also a bitmap. The last member, `mrt_next`, implements a linked list in case multiple routes hash to the same array entry.

Figure 14.29 shows the organization of the multicast routing table. Each `mrt` structure is placed in the hash chain that corresponds to return value from the `nethash` function shown in Figure 14.31.

The multicast routing table maintained by the kernel is a subset of the routing table maintained within `mROUTED` and contains enough information to support multicast forwarding within the kernel. Updates to the kernel table are sent with the `DVMRP_ADD_MRT` command, which includes the `mrtctl` structure shown in Figure 14.30.

sed,

the

t/3,

MP

IRP

y a

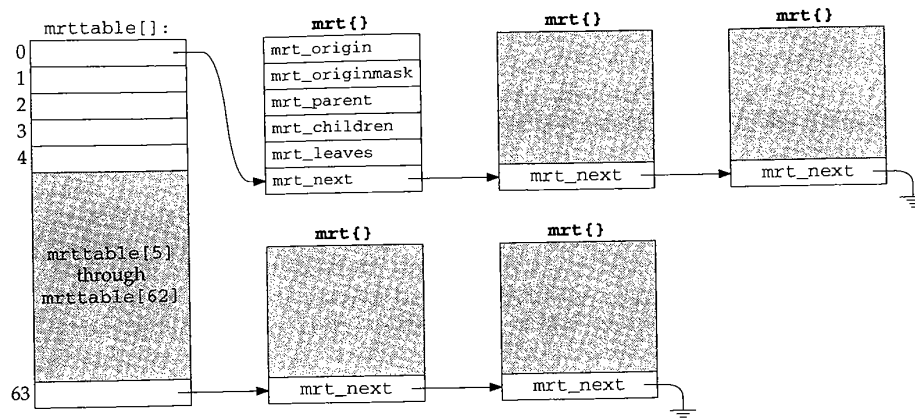

Figure 14.29 Multicast routing table.

```

95 struct mrtctl {
96     struct in_addr mrtc_origin; /* subnet origin of multicasts */
97     struct in_addr mrtc_originmask; /* subnet mask for origin */
98     vifi_t mrtc_parent; /* incoming vif */
99     vifbitmap_t mrtc_children; /* outgoing children vifs */
100    vifbitmap_t mrtc_leaves; /* subset of outgoing children vifs */
101 };

```

*ip\_mroute.h*

Figure 14.30 mrtctl structure.

95-101 The five members of the mrtctl structure carry the information we have already described (Figure 14.28) between mroute and the kernel.

The multicast routing table is keyed by the source IP address of the multicast datagram. nethash (Figure 14.31) implements the hashing algorithm used for the table. It accepts the source IP address and returns a value between 0 and 63 ( $MRTHASHSIZ - 1$ ).

```

398 static u_long
399 nethash(in)
400 struct in_addr in;
401 {
402     u_long n;
403     n = in_netof(in);
404     while ((n & 0xff) == 0)
405         n >>= 8;
406     return (MRTHASHMOD(n));
407 }

```

*ip\_mroute.c*

Figure 14.31 nethash function.



398-407 `in_netof` returns `in` with the host portion set to all 0s leaving only the class A, B, or C network of the sending host in `n`. The result is shifted to the right until the low-order 8 bits are nonzero. `MRTHASHMOD` is

```
#define MRTHASHMOD(h) ((h) & (MRTHASHSIZ - 1))
```

The low-order 8 bits are logically ANDed with 63, leaving only the low-order 6 bits, which is an integer in the range 0 to 63.

Doing two function calls (`nethash` and `in_netof`) to calculate a hash value is an expensive algorithm to compute a hash for a 32-bit address.

### del\_mrt Function

The `mROUTED` daemon adds and deletes entries in the kernel's multicast routing table through the `DVMRP_ADD_MRT` and `DVMRP_DEL_MRT` commands. Figure 14.32 shows the `del_mrt` function.

```
451 static int                                     ip_mroute.c
452 del_mrt(origin)
453 struct in_addr *origin;
454 {
455     struct mrt *rt, *prev_rt;
456     u_long hash = nethash(*origin);
457     int s;
458     for (prev_rt = rt = mrttable[hash]; rt; prev_rt = rt, rt = rt->mrt_next)
459         if (origin->s_addr == rt->mrt_origin.s_addr)
460             break;
461     if (!rt)
462         return (ESRCH);
463     s = splnet();
464     if (rt == cached_mrt)
465         cached_mrt = NULL;
466     if (prev_rt == rt)
467         mrttable[hash] = rt->mrt_next;
468     else
469         prev_rt->mrt_next = rt->mrt_next;
470     free(rt, M_MRTABLE);
471     splx(s);
472     return (0);
473 }
```

Figure 14.32 `del_mrt` function: process `DVMRP_DEL_MRT` command.

### Find route entry

451-462 The `for` loop starts at the entry identified by `hash` (initialized in its declaration from `nethash`). If the entry is not located, `ESRCH` is returned.

**Delete route entry**

463-473 If the entry was stored in the cache, the cache is invalidated. The entry is unlinked from the hash chain and released. The `if` statement is needed to handle the special case when the matched entry is at the front of the list.

**add\_mrt Function**

The `add_mrt` function is shown in Figure 14.33.

```

411 static int
412 add_mrt(mrtcp)
413 struct mrtctl *mrtcp;
414 {
415     struct mrt *rt;
416     u_long hash;
417     int s;
418
419     if (rt = mrtfind(mrtcp->mrtc_origin)) {
420         /* Just update the route */
421         s = splnet();
422         rt->mrt_parent = mrtcp->mrtc_parent;
423         VIFM_COPY(mrtcp->mrtc_children, rt->mrt_children);
424         VIFM_COPY(mrtcp->mrtc_leaves, rt->mrt_leaves);
425         splx(s);
426         return (0);
427     }
428     s = splnet();
429
430     rt = (struct mrt *) malloc(sizeof(*rt), M_MRTABLE, M_NOWAIT);
431     if (rt == NULL) {
432         splx(s);
433         return (ENOBUFS);
434     }
435     /*
436      * insert new entry at head of hash chain
437      */
438     rt->mrt_origin = mrtcp->mrtc_origin;
439     rt->mrt_originmask = mrtcp->mrtc_originmask;
440     rt->mrt_parent = mrtcp->mrtc_parent;
441     VIFM_COPY(mrtcp->mrtc_children, rt->mrt_children);
442     VIFM_COPY(mrtcp->mrtc_leaves, rt->mrt_leaves);
443     /* link into table */
444     hash = nethash(mrtcp->mrtc_origin);
445     rt->mrt_next = mrttable[hash];
446     mrttable[hash] = rt;
447
448     splx(s);
449     return (0);
450 }

```

ip\_mroute.c

ip\_mroute.c

Figure 14.33 `add_mrt` function: process `DVMRP_ADD_MRT` command.

**Update existing route**

411-427 If the requested route is already in the routing table, the new information is copied into the route and `add_mrt` returns.

**Allocate new route**

428-447 An `mrt` structure is constructed in a newly allocated mbuf with the information from `mrtctl` structure passed with the add request. The hash index is computed from `mrtc_origin`, and the new route is inserted as the first entry on the hash chain.

**mrtfind Function**

The multicast routing table is searched with the `mrtfind` function. The source of the datagram is passed to `mrtfind`, which returns a pointer to the matching `mrt` structure, or a null pointer if there is no match.

```

477 static struct mrt *
478 mrtfind(origin)
479 struct in_addr origin;
480 {
481     struct mrt *rt;
482     u_int hash;
483     int s;
484     mrtstat.mrts_mrt_lookups++;
485     if (cached_mrt != NULL &&
486         (origin.s_addr & cached_originmask) == cached_origin)
487         return (cached_mrt);
488     mrtstat.mrts_mrt_misses++;
489     hash = nethash(origin);
490     for (rt = mrttable[hash]; rt; rt = rt->mrt_next)
491         if ((origin.s_addr & rt->mrt_originmask.s_addr) ==
492             rt->mrt_origin.s_addr) {
493             s = splnet();
494             cached_mrt = rt;
495             cached_origin = rt->mrt_origin.s_addr;
496             cached_originmask = rt->mrt_originmask.s_addr;
497             splx(s);
498             return (rt);
499         }
500     return (NULL);
501 }

```

*ip\_mroute.c*

*ip\_mroute.c*

Figure 14.34 `mrtfind` function.

**Check route lookup cache**

477-488 The given source IP address (`origin`) is logically ANDed with the origin mask in the cache. If the result matches `cached_origin`, the cached entry is returned.

**Check the hash table**

489-501 `nethash` returns the hash index for the route entry. The `for` loop searches the hash chain for a matching route. When a match is found, the cache is updated and a pointer to the route is returned. If a match is not found, a null pointer is returned.

**14.8 Multicast Forwarding: `ip_mforward` Function**

Multicast forwarding is implemented entirely in the kernel. We saw in Figure 12.39 that `ipintr` passes incoming multicast datagrams to `ip_mforward` when `ip_router` is nonnull, that is, when `mouted` is running.

We also saw in Figure 12.40 that `ip_output` can pass multicast datagrams that originate on the local host to `ip_mforward` to be routed to interfaces other than the one interface selected by `ip_output`.

Unlike unicast forwarding, each time a multicast datagram is forwarded to an interface, a copy is made. For example, if the local host is acting as a multicast router and is connected to three different networks, multicast datagrams originating on the system are duplicated and queued for *output* on all three interfaces. Additionally, the datagram may be duplicated and queued for *input* if the multicast loopback flag was set by the application or if any of the outgoing interfaces receive their own transmissions.

Figure 14.35 shows a multicast datagram arriving on a physical interface.

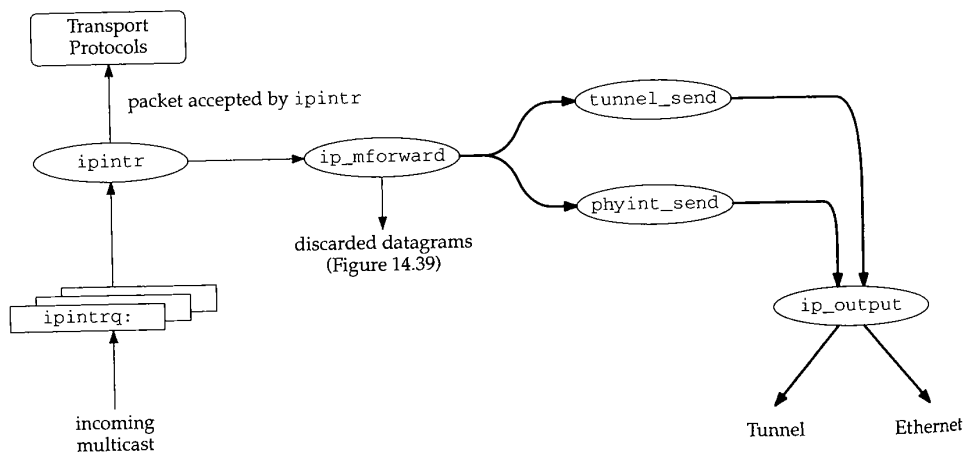

Figure 14.35 Multicast datagram arriving on physical interface.

In Figure 14.35, the interface on which the datagram arrived is a member of the destination group, so the datagram is passed to the transport protocols for input processing. The datagram is also passed to `ip_mforward`, where it is duplicated and

hes the  
d and a  
l.

2.39 that  
uter is

ams that  
a the one

an inter-  
er and is  
e system  
datagram  
et by the

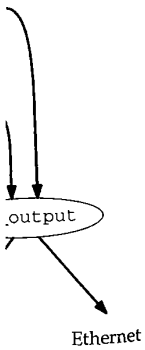

r of the des-  
out process-  
licated and

forwarded to a physical interface and to a tunnel (the thick arrows), both of which must be different from the receiving interface.

Figure 14.36 shows a multicast datagram arriving on a tunnel.

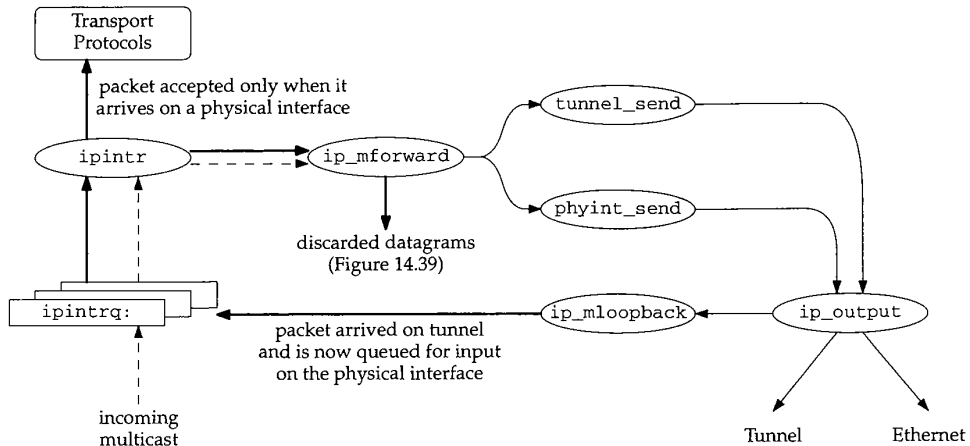

Figure 14.36 Multicast datagram arriving on a multicast tunnel.

In Figure 14.36, the datagram arriving on a physical interface associated with the local end of the tunnel is represented by the dashed arrows. It is passed to ip\_mforward, which as we'll see in Figure 14.37 returns a nonzero value because the packet arrived on a tunnel. This causes ipintr to not pass the packet to the transport protocols.

ip\_mforward strips the tunnel options from the packet, consults the multicast routing table, and, in this example, forwards the packet on another tunnel and on the same physical interface on which it arrived, as shown by the thin arrows. This is OK because the multicast routing tables are based on the virtual interfaces, not the physical interfaces.

In Figure 14.36 we assume that the physical interface is a member of the destination group, so ip\_output passes the datagram to ip\_mloopback, which queues it for processing by ipintr (the thick arrows). The packet is passed to ip\_mforward again, where it is discarded (Exercise 14.4). ip\_mforward returns 0 this time (because the packet arrived on a physical interface), so ipintr considers and accepts the datagram for input processing.

We show the multicast forwarding code in three parts:

- tunnel input processing (Figure 14.37),
- forwarding eligibility (Figure 14.39), and
- forward to outgoing interfaces (Figure 14.40).

```

516 int
517 ip_mforward(m, ifp)
518 struct mbuf *m;
519 struct ifnet *ifp;
520 {
521     struct ip *ip = mtod(m, struct ip *);
522     struct mrt *rt;
523     struct vif *vifp;
524     int vifi;
525     u_char *ipoptions;
526     u_long tunnel_src;

527     if (ip->ip_hl < (IP_HDR_LEN + TUNNEL_LEN) >> 2 ||
528         (ipoptions = (u_char *) (ip + 1))[1] != IPOPT_LSRR) {
529         /* Packet arrived via a physical interface. */
530         tunnel_src = 0;
531     } else {
532         /*
533          * Packet arrived through a tunnel.
534          * A tunneled packet has a single NOP option and a
535          * two-element loose-source-and-record-route (LSRR)
536          * option immediately following the fixed-size part of
537          * the IP header. At this point in processing, the IP
538          * header should contain the following IP addresses:
539          *
540          * original source - in the source address field
541          * destination group - in the destination address field
542          * remote tunnel end-point - in the first element of LSRR
543          * one of this host's addr - in the second element of LSRR
544          *
545          * NOTE: RFC-1075 would have the original source and
546          * remote tunnel end-point addresses swapped. However,
547          * that could cause delivery of ICMP error messages to
548          * innocent applications on intermediate routing
549          * hosts! Therefore, we hereby change the spec.
550          */
551         /* Verify that the tunnel options are well-formed. */
552         if (ipoptions[0] != IPOPT_NOP ||
553             ipoptions[2] != 11 || /* LSRR option length */
554             ipoptions[3] != 12 || /* LSRR address pointer */
555             (tunnel_src = *(u_long *) (&ipoptions[4])) == 0) {
556             mrtstat.mrts_bad_tunnel++;
557             return (1);
558         }
559         /* Delete the tunnel options from the packet. */
560         ovbcopy((caddr_t) (ipoptions + TUNNEL_LEN), (caddr_t) ipoptions,
561             (unsigned) (m->m_len - (IP_HDR_LEN + TUNNEL_LEN)));
562         m->m_len -= TUNNEL_LEN;
563         ip->ip_len -= TUNNEL_LEN;
564         ip->ip_hl -= TUNNEL_LEN >> 2;
565     }
}

```

Figure 14.37 ip\_mforward function: tunnel arrival.

tte.c

516-526 The two arguments to ip\_mforward are a pointer to the mbuf chain containing the datagram; and a pointer to the ifnet structure of the receiving interface.

**Arrival on physical interface**

527-530 To distinguish between a multicast datagram arriving on a physical interface and a tunneled datagram arriving on the same physical interface, the IP header is examined for the characteristic LSRR option. If the header is too small to contain the option, or if the options don't start with a NOP followed by an LSRR option, it is assumed that the datagram arrived on a physical interface and tunnel\_src is set to 0.

**Arrival on a tunnel**

531-558 If the datagram looks as though it arrived on a tunnel, the options are verified to make sure they are well formed. If the options are not well formed for a multicast tunnel, ip\_mforward returns 1 to indicate that the datagram should be discarded. Figure 14.38 shows the organization of the tunnel options.

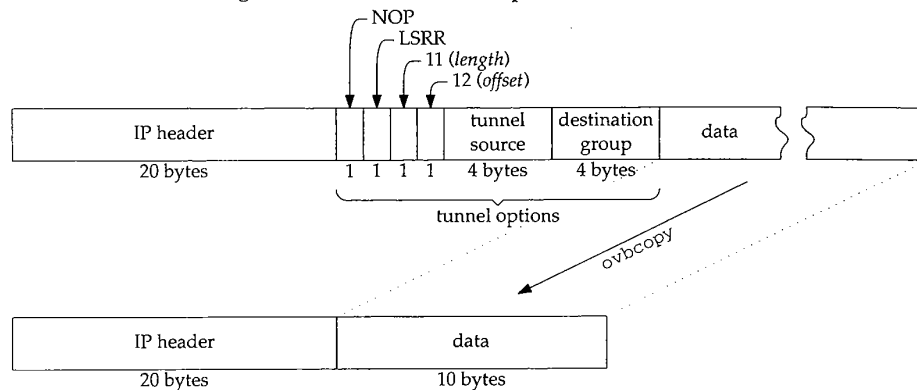

Figure 14.38 Multicast tunnel options.

In Figure 14.38 we assume there are no other options in the datagram, although that is not required. Any other IP options will appear after the LSRR option, which is always inserted before any other options by the multicast router at the start of the tunnel.

**Delete tunnel options**

559-565 If the options are OK, they are removed from the datagram by shifting the remaining options and data forward and adjusting m\_len in the mbuf header and ip\_len and ip\_hl in the IP header (Figure 14.38).

ip\_mforward often uses tunnel\_source as its return value, which is only nonzero when the datagram arrives on a tunnel. When ip\_mforward returns a nonzero value, the caller discards the datagram. For ipintr this means that a datagram that arrives on a tunnel is passed to ip\_mforward and discarded by ipintr. The forwarding code strips out the tunnel information, duplicates the datagram, and sends the datagrams with ip\_output, which calls ip\_mloopback if the interface is a member of the destination group.

route.c

The next part of `ip_mforward`, shown in Figure 14.39, discards the datagram if it is ineligible for forwarding.

```

566  /*
567  * Don't forward a packet with time-to-live of zero or one,
568  * or a packet destined to a local-only group.
569  */
570  if (ip->ip_ttl <= 1 ||
571      ntohl(ip->ip_dst.s_addr) <= INADDR_MAX_LOCAL_GROUP)
572      return ((int) tunnel_src);

573  /*
574  * Don't forward if we don't have a route for the packet's origin.
575  */
576  if (!(rt = mrtfind(ip->ip_src))) {
577      mrtstat.mrts_no_route++;
578      return ((int) tunnel_src);
579  }
580  /*
581  * Don't forward if it didn't arrive from the parent vif for its origin.
582  */
583  vifi = rt->mrt_parent;
584  if (tunnel_src == 0) {
585      if ((viftable[vifi].v_flags & VIFF_TUNNEL) ||
586          viftable[vifi].v_ifp != ifp)
587          return ((int) tunnel_src);
588  } else {
589      if (!(viftable[vifi].v_flags & VIFF_TUNNEL) ||
590          viftable[vifi].v_rmt_addr.s_addr != tunnel_src)
591          return ((int) tunnel_src);
592  }

```

ip\_mroute.c

586

Figure 14.39 `ip_mforward` function: forwarding eligibility checks.

#### Expired TTL or local multicast

566-572 If `ip_ttl` is 0 or 1, the datagram has reached the end of its lifetime and is not forwarded. If the destination group is less than or equal to `INADDR_MAX_LOCAL_GROUP` (the 224.0.0.x groups, Figure 12.1), the datagram is not allowed beyond the local network and is not forwarded. In either case, `tunnel_src` is returned to the caller.

Version 3.3 of `mROUTED` supports administrative scoping of certain destination groups. An interface can be configured to discard datagrams addressed to these groups, similar to the automatic scoping of the 224.0.0.x groups.

593-

#### No route available

573-579 If `mrtfind` cannot locate a route based on the *source* address of the datagram, the function returns. Without a route, the multicast router cannot determine to which interfaces the datagram should be forwarded. This might occur, for example, when the multicast datagrams arrive before the multicast routing table has been updated by `mROUTED`.



**Arrived on unexpected interface**

580-592 If the datagram arrived on a physical interface but was expected to arrive on a tunnel or on a different physical interface, `ip_mforward` returns. If the datagram arrived on a tunnel but was expected to arrive on a physical interface or on a different tunnel, `ip_mforward` returns. A datagram may arrive on an unexpected interface when the routing tables are in transition because of changes in the group membership or in the physical topology of the network.

The final part of `ip_mforward` (Figure 14.40) sends the datagram on each of the outgoing interfaces specified in the multicast route entry.

```

593  /*-----ip_mroute.c
594  * For each vif, decide if a copy of the packet should be forwarded.
595  * Forward if:
596  *   - the ttl exceeds the vif's threshold AND
597  *   - the vif is a child in the origin's route AND
598  *   - ( the vif is not a leaf in the origin's route OR
599  *     the destination group has members on the vif )
600  *
601  * (This might be speeded up with some sort of cache -- someday.)
602  */
603  for (vifp = viftable, vifi = 0; vifi < numvifs; vifp++, vifi++) {
604      if (ip->ip_ttl > vifp->v_threshold &&
605          VIFM_ISSET(vifi, rt->mrt_children) &&
606          (!VIFM_ISSET(vifi, rt->mrt_leaves) ||
607           grplst_member(vifp, ip->ip_dst))) {
608          if (vifp->v_flags & VIFF_TUNNEL)
609              tunnel_send(m, vifp);
610          else
611              phyint_send(m, vifp);
612      }
613  }
614  return ((int) tunnel_src);
615 }
-----ip_mroute.c

```

Figure 14.40 `ip_mforward` function: forwarding.

593-615 For each interface in `viftable`, a datagram is sent on the interface if

- the datagram's TTL is greater than the multicast threshold for the interface,
- the interface is a child interface for the route, and
- the interface is not connected to a leaf network.

If the interface is a leaf, the datagram is output only if there is a member of the destination group on the network (i.e., `grplst_member` returns a nonzero value).

`tunnel_send` forwards the datagram on tunnel interfaces; `phyint_send` is used for physical interfaces.

**phyint\_send Function**

To send a multicast datagram on a physical interface, `phyint_send` (Figure 14.41) specifies the output interface explicitly in the `ip_moptions` structure it passes to `ip_output`.

```

616 static void                                     ip_mroute.c
617 phyint_send(m, vifp)
618 struct mbuf *m;
619 struct vif *vifp;
620 {
621     struct ip *ip = mtod(m, struct ip *);
622     struct mbuf *mb_copy;
623     struct ip_moptions *imo;
624     int error;
625     struct ip_moptions simo;
626
627     mb_copy = m_copy(m, 0, M_COPYALL);
628     if (mb_copy == NULL)
629         return;
630
631     imo = &simo;
632     imo->imo_multicast_ifp = vifp->v_ifp;
633     imo->imo_multicast_ttl = ip->ip_ttl - 1;
634     imo->imo_multicast_loop = 1;
635
636     error = ip_output(mb_copy, NULL, NULL, IP_FORWARDING, imo);
637 }

```

Figure 14.41 `phyint_send` function.

<sup>616-634</sup> `m_copy` duplicates the outgoing datagram. The `ip_moptions` structure is set to force the datagram to be transmitted on the selected interface. The TTL value is decremented, and multicast loopback is enabled.

The datagram is passed to `ip_output`. The `IP_FORWARDING` flag avoids an infinite loop, where `ip_output` calls `ip_mforward` again.

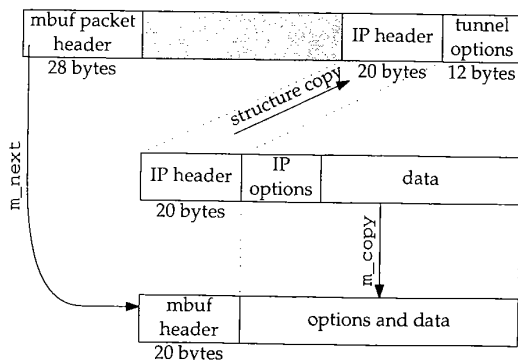

Figure 14.42 Inserting tunnel options.

**tunnel\_send Function**

1) To send a datagram on a tunnel, `tunnel_send` (Figure 14.43) must construct the appropriate tunnel options and insert them in the header of the outgoing datagram. Figure 14.42 shows how `tunnel_send` prepares a packet for the tunnel.

```

2.c
635 static void
636 tunnel_send(m, vifp)
637 struct mbuf *m;
638 struct vif *vifp;
639 {
640     struct ip *ip = mtod(m, struct ip *);
641     struct mbuf *mb_copy, *mb_opts;
642     struct ip *ip_copy;
643     int error;
644     u_char *cp;
645     /*
646      * Make sure that adding the tunnel options won't exceed the
647      * maximum allowed number of option bytes.
648      */
649     if (ip->ip_hl > (60 - TUNNEL_LEN) >> 2) {
650         mrtstat.mrts_cant_tunnel++;
651         return;
652     }
653     /*
654      * Get a private copy of the IP header so that changes to some
655      * of the IP fields don't damage the original header, which is
656      * examined later in ip_input.c.
657      */
658     mb_copy = m_copy(m, IP_HDR_LEN, M_COPYALL);
659     if (mb_copy == NULL)
660         return;
661     MGETHDR(mb_opts, M_DONTWAIT, MT_HEADER);
662     if (mb_opts == NULL) {
663         m_freem(mb_copy);
664         return;
665     }
666     /*
667      * Make mb_opts be the new head of the packet chain.
668      * Any options of the packet were left in the old packet chain head
669      */
670     mb_opts->m_next = mb_copy;
671     mb_opts->m_len = IP_HDR_LEN + TUNNEL_LEN;
672     mb_opts->m_data += MSIZE - mb_opts->m_len;

```

*ip\_mroute.c*

Figure 14.43 `tunnel_send` function: verify and allocate new header.

**Will the tunnel options fit?**

635-652 If there is no room in the IP header for the tunnel options, `tunnel_send` returns immediately and the datagram is not forwarded on the tunnel. It may be forwarded on other interfaces.

**Duplicate the datagram and allocate mbuf for new header and tunnel options**

653-672 In the call to `m_copy`, the starting offset for the copy is 20 (`IP_HDR_LEN`). The resulting mbuf chain contains the options and data for the datagram but not the IP header. `mb_opts` points to a new datagram header allocated by `MGETHDR`. The datagram header is prepended to `mb_copy`. Then `m_len` and `m_data` are adjusted to accommodate an IP header and the tunnel options.

66

The second half of `tunnel_send`, shown in Figure 14.44, modifies the headers of the outgoing packet and sends the packet.

14

```

673     ip_copy = mtod(mb_opts, struct ip *);
674     /*
675      * Copy the base ip header to the new head mbuf.
676      */
677     *ip_copy = *ip;
678     ip_copy->ip_ttl--;
679     ip_copy->ip_dst = vifp->v_rmt_addr;    /* remote tunnel end-point */
680     /*
681      * Adjust the ip header length to account for the tunnel options.
682      */
683     ip_copy->ip_hl += TUNNEL_LEN >> 2;
684     ip_copy->ip_len += TUNNEL_LEN;
685     /*
686      * Add the NOP and LSRR after the base ip header
687      */
688     cp = (u_char *) (ip_copy + 1);
689     *cp++ = IPOPT_NOP;
690     *cp++ = IPOPT_LSRR;
691     *cp++ = 11;                /* LSRR option length */
692     *cp++ = 8;                /* LSRR pointer to second element */
693     *(u_long *) cp = vifp->v_lcl_addr.s_addr; /* local tunnel end-point */
694     cp += 4;
695     *(u_long *) cp = ip->ip_dst.s_addr;    /* destination group */
696     error = ip_output(mb_opts, NULL, NULL, IP_FORWARDING, NULL);
697 }

```

Figure 14.44 `tunnel_send` function: construct headers and send.

**Modify IP header**

673-679 The original IP header is copied from the original mbuf chain into the newly allocated mbuf header. The TTL in the header is decremented, and the destination is changed to be the other end of the tunnel.

**Construct tunnel options**

680-664 `ip_hl` and `ip_len` are adjusted to accommodate the tunnel options. The tunnel options are placed just after the IP header: a NOP, followed by the LSRR code, the length of the LSRR option (11 bytes), and a pointer to the *second* address in the option (8 bytes). The source route consists of the local tunnel end point followed by the destination group (Figure 14.13).

**Send the tunneled datagram**

665-697 ip\_output sends the datagram, which now looks like a unicast datagram with an LSRR option since the destination address is the unicast address of the other end of the tunnel. When it reaches the other end of the tunnel, the tunnel options are stripped off and the datagram is forwarded at that point, possibly through additional tunnels.

**14.9 Cleanup: ip\_router\_done Function**

When mrouterd shuts down, it issues the DVMRP\_DONE command, which is handled by the ip\_router\_done function shown in Figure 14.45.

```

161 int
162 ip_router_done()
163 {
164     vifi_t vifi;
165     int i;
166     struct ifnet *ifp;
167     int s;
168     struct ifreq ifr;
169     s = splnet();
170     /*
171      * For each phyint in use, free its local group list and
172      * disable promiscuous reception of all IP multicasts.
173      */
174     for (vifi = 0; vifi < numvifs; vifi++) {
175         if (viftable[vifi].v_lcl_addr.s_addr != 0 &&
176             !(viftable[vifi].v_flags & VIFF_TUNNEL)) {
177             if (viftable[vifi].v_lcl_grps)
178                 free(viftable[vifi].v_lcl_grps, M_MRTABLE);
179             satosin(&ifr.ifr_addr)->sin_family = AF_INET;
180             satosin(&ifr.ifr_addr)->sin_addr.s_addr = INADDR_ANY;
181             ifp = viftable[vifi].v_ifp;
182             (*ifp->if_ioctl) (ifp, SIOCDELMULTI, (caddr_t) & ifr);
183         }
184     }
185     bzero((caddr_t) viftable, sizeof(viftable));
186     numvifs = 0;
187     /*
188      * Free any multicast route entries.
189      */
190     for (i = 0; i < MRTHASHSIZ; i++)
191         if (mrttable[i])
192             free(mrttable[i], M_MRTABLE);
193     bzero((caddr_t) mrttable, sizeof(mrttable));
194     cached_mrt = NULL;
195     ip_router = NULL;
196     splx(s);
197     return (0);
198 }

```

ip\_mroute.c

ip\_mroute.c

Figure 14.45 ip\_router\_done function: DVMRP\_DONE command.

- 161-186 This function runs at `splnet` to avoid any interaction with the multicast forwarding code. For every physical multicast interface, the list of local groups is released and the `SIOCDELMULTI` command is issued to stop receiving multicast datagrams (Exercise 14.3). The entire `viftable` array is cleared by `bzero` and `numvifs` is set to 0.
- 187-198 Every active entry in the multicast routing table is released, the entire table is cleared with `bzero`, the cache is cleared, and `ip_mrouter` is reset.

Each entry in the multicast routing table may be the first in a linked list of entries. This code introduces a memory leak by releasing only the first entry in the list.

## 14.10 Summary

In this chapter we described the general concept of internetwork multicasting and the specific functions within the Net/3 kernel that support it. We did not discuss the implementation of `mouted`, but the source is readily available for the interested reader.

We described the virtual interface table and the differences between a physical interface and a tunnel, as well as the LSRR options used to implement tunnels in Net/3.

We illustrated the RPB, TRPB, and RPM algorithms and described the kernel tables used to forward multicast datagrams according to TRPB. The concept of parent and leaf networks was also discussed.

## Exercises

- 14.1 In Figure 14.25, how many multicast routes are needed?
- 14.2 Why is the update to the group membership cache in Figure 14.23 protected by `splnet` and `splx`?
- 14.3 What happens when `SIOCDELMULTI` is issued for an interface that has explicitly joined a multicast group with the `IP_ADD_MEMBERSHIP` option?
- 14.4 When a datagram arrives on a tunnel and is accepted by `ip_mforward`, it may be looped back by `ip_output` when it is forwarded to a physical interface. Why does `ip_mforward` discard the looped-back packet when it arrives on the physical interface?
- 14.5 Redesign the group address cache to increase its effectiveness.

## 15.1 Intr

This  
abst  
face  
cuss  
from

from  
crea

netv  
grat  
acce  
thro  
wri  
wor

not c  
tion:  
gran  
prot

# 15

## Socket Layer

### 15.1 Introduction

This chapter is the first of three that cover the socket-layer code in Net/3. The socket abstraction was introduced with the 4.2BSD release in 1983 to provide a uniform interface to network and interprocess communication protocols. The Net/3 release discussed here is based on the 4.3BSD Reno version of sockets, which is slightly different from the earlier 4.2 releases used by many Unix vendors.

As described in Section 1.7, the socket layer maps protocol-independent requests from a process to the protocol-specific implementation selected when the socket was created.

To allow standard Unix I/O system calls such as `read` and `write` to operate with network connections, the filesystem and networking facilities in BSD releases are integrated at the system call level. Network connections represented by sockets are accessed through a descriptor (a small integer) in the same way an open file is accessed through a descriptor. This allows the standard filesystem calls such as `read` and `write`, as well as network-specific system calls such as `sendmsg` and `recvmsg`, to work with a descriptor associated with a socket.

Our focus is on the implementation of sockets and the associated system calls and not on how a typical program might use the socket layer to implement network applications. For a detailed discussion of the process-level socket interface and how to program network applications see [Stevens 1990] and [Rago 1993].

Figure 15.1 shows the layering between the socket interface in a process and the protocol implementation in the kernel.

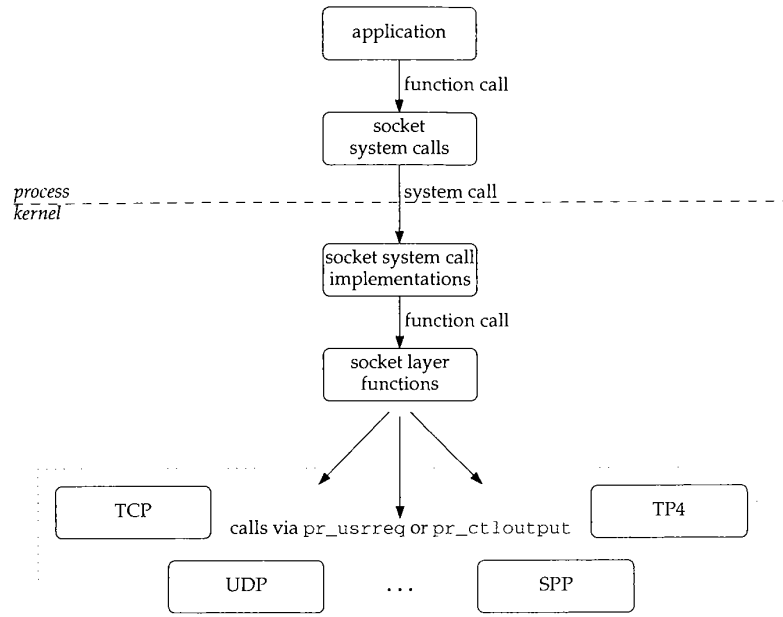

Figure 15.1 The socket layer converts generic requests to specific protocol operations.

### splnet Processing

The socket layer contains many paired calls to `splnet` and `splx`. As discussed in Section 1.12, these calls protect code that accesses data structures shared between the socket layer and the protocol-processing layer. Without calls to `splnet`, a software interrupt that initiates protocol processing and changes the shared data structures will confuse the socket-layer code when it resumes.

We assume that readers understand these calls and we rarely point them out in our discussion.

## 15.2 Code Introduction

The three files listed in Figure 15.2 are described in this chapter.

### Global Variables

The two global variables covered in this chapter are described in Figure 15.3.



File	Description
sys/socketvar.h	socket structure definitions
kern/uipc_syscalls.c	system call implementation
kern/uipc_socket.c	socket-layer functions

Figure 15.2 Files discussed in this chapter.

Variable	Datatype	Description
socketops	struct fileops	socket implementation of I/O system calls
sysent	struct sysent[]	array of system call entries

Figure 15.3 Global variable introduced in this chapter.

### 15.3 socket Structure

A socket represents one end of a communication link and holds or points to all the information associated with the link. This information includes the protocol to use, state information for the protocol (which includes source and destination addresses), queues of arriving connections, data buffers, and option flags. Figure 15.5 shows the definition of a socket and its associated buffers.

41-42 `so_type` is specified by the process creating a socket and identifies the communication semantics to be supported by the socket and the associated protocol. `so_type` shares the same values as `pr_type` shown in Figure 7.8. For UDP, `so_type` would be `SOCK_DGRAM` and for TCP it would be `SOCK_STREAM`.

43 `so_options` is a collection of flags that modify the behavior of a socket. Figure 15.4 describes the flags.

so_options	Kernel only	Description
<code>SO_ACCEPTCONN</code>	•	socket accepts incoming connections
<code>SO_BROADCAST</code>		socket can send broadcast messages
<code>SO_DEBUG</code>		socket records debugging information
<code>SO_DONTROUTE</code>		output operations bypass routing tables
<code>SO_KEEPAIVE</code>		socket probes idle connections
<code>SO_OOBINLINE</code>		socket keeps out-of-band data inline
<code>SO_REUSEADDR</code>		socket can reuse a local address
<code>SO_REUSEPORT</code>		socket can reuse a local address and port
<code>SO_USELOOPBACK</code>		routing domain sockets only; sending process receives its own routing requests

Figure 15.4 `so_options` values.

A process can modify all the socket options with the `getsockopt` and `setsockopt` system calls except `SO_ACCEPTCONN`, which is set by the kernel when the `listen` system call is issued on the socket.

```

41 struct socket {
42     short    so_type;           /* generic type, Figure 7.8 */
43     short    so_options;       /* from socket call, Figure 15.4 */
44     short    so_linger;        /* time to linger while closing */
45     short    so_state;         /* internal state flags, Figure 15.6 */
46     caddr_t  so_pcb;           /* protocol control block */
47     struct  protosw *so_proto; /* protocol handle */
48 /*
49  * Variables for connection queueing.
50  * Socket where accepts occur is so_head in all subsidiary sockets.
51  * If so_head is 0, socket is not related to an accept.
52  * For head socket so_q0 queues partially completed connections,
53  * while so_q is a queue of connections ready to be accepted.
54  * If a connection is aborted and it has so_head set, then
55  * it has to be pulled out of either so_q0 or so_q.
56  * We allow connections to queue up based on current queue lengths
57  * and limit on number of queued connections for this socket.
58  */
59     struct  socket *so_head;    /* back pointer to accept socket */
60     struct  socket *so_q0;      /* queue of partial connections */
61     struct  socket *so_q;       /* queue of incoming connections */
62     short   so_q0len;          /* partials on so_q0 */
63     short   so_qlen;           /* number of connections on so_q */
64     short   so_qlimit;         /* max number queued connections */
65     short   so_timeout;        /* connection timeout */
66     u_short so_error;          /* error affecting connection */
67     pid_t   so_pgid;           /* ppid for signals */
68     u_long  so_oobmark;        /* chars to oob mark */
69 /*
70  * Variables for socket buffering.
71  */
72     struct  sockbuf {
73         u_long  sb_cc;          /* actual chars in buffer */
74         u_long  sb_hiwat;       /* max actual char count */
75         u_long  sb_mbcnt;       /* chars of mbufs used */
76         u_long  sb_mbmax;       /* max chars of mbufs to use */
77         long    sb_lowat;       /* low water mark */
78         struct  mbuf *sb_mb;     /* the mbuf chain */
79         struct  selinfo sb_sel; /* process selecting read/write */
80         short   sb_flags;       /* Figure 16.5 */
81         short   sb_timeout;     /* timeout for read/write */
82     } so_rcv, so_snd;
83     caddr_t  so_tpcb;          /* Wisc. protocol control block XXX */
84     void     (*so_upcall) (struct socket * so, caddr_t arg, int waitf);
85     caddr_t  so_upcallarg;     /* Arg for above */
86 };

```

Figure 15.5 struct socket definition.

- 44 `so_linger` is the time in clock ticks that a socket waits for data to drain while closing a connection (Section 15.15).
- 45 `so_state` represents the internal state and additional characteristics of the socket. Figure 15.6 lists the possible values for `so_state`.

so_state	Kernel only	Description
<i>SS_ASYNC</i>		socket should send asynchronous notification of I/O events
<i>SS_NBIO</i>		socket operations should not block the process
<i>SS_CANTRCVMORE</i>	•	socket cannot receive more data from peer
<i>SS_CANTSENDMORE</i>	•	socket cannot send more data to peer
<i>SS_ISCONFIRMING</i>	•	socket is negotiating a connection request
<i>SS_ISCONNECTED</i>	•	socket is connected to a foreign socket
<i>SS_ISCONNECTING</i>	•	socket is connecting to a foreign socket
<i>SS_ISDISCONNECTING</i>	•	socket is disconnecting from peer
<i>SS_NOFDREF</i>	•	socket is not associated with a descriptor
<i>SS_PRIV</i>	•	socket was created by a process with superuser privileges
<i>SS_RCVATMARK</i>	•	process has consumed all data received before the most recent out-of-band data was received

Figure 15.6 `so_state` values.

In Figure 15.6, the middle column shows that `SS_ASYNC` and `SS_NBIO` can be changed explicitly by a process by the `fcntl` and `ioctl` system calls. The other flags are implicitly changed by the process during the execution of system calls. For example, if the process calls `connect`, the `SS_ISCONNECTED` flag is set by the kernel when the connection is established.

### `SS_NBIO` and `SS_ASYNC` Flags

By default, a process blocks waiting for resources when it makes an I/O request. For example, a `read` system call on a socket blocks if there is no data available from the network. When the data arrives, the process is unblocked and `read` returns. Similarly, when a process calls `write`, the kernel blocks the process until space is available in the kernel for the data. If `SS_NBIO` is set, the kernel does not block a process during I/O on the socket but instead returns the error code `EWOULDBLOCK`.

If `SS_ASYNC` is set, the kernel sends the `SIGIO` signal to the process or process group specified by `so_pgid` when the status of the socket changes for one of the following reasons:

- a connection request has completed,
- a disconnect request has been initiated,
- a disconnect request has completed,
- half of a connection has been shut down,
- data has arrived on a socket,
- data has been sent from a socket (i.e., the output buffer has free space), or
- an asynchronous error has occurred on a UDP or TCP socket.

46 `so_pcb` points to a protocol control block that contains protocol-specific state information and parameters for the socket. Each protocol defines its own control block structure, so `so_pcb` is defined to be a generic pointer. Figure 15.7 lists the control block structures that we discuss.

`so_pcb` never points to a `tcpcb` structure directly; see Figure 22.1.

Protocol	Control block	Reference
UDP	struct <code>inpcb</code>	Section 22.3
TCP	struct <code>inpcb</code> struct <code>tcpcb</code>	Section 22.3 Section 24.5
ICMP, IGMP, raw IP	struct <code>inpcb</code>	Section 22.3
Route	struct <code>rawcb</code>	Section 20.3

Figure 15.7 Protocol control blocks.

47 `so_proto` points to the `protosw` structure of the protocol selected by the process during the socket system call (Section 7.4).

48-64 Sockets with `SO_ACCEPTCONN` set maintain two connection queues. Connections that are not yet established (e.g., the TCP three-way handshake is not yet complete) are placed on the queue `so_q0`. Connections that are established and are ready to be accepted (e.g., the TCP three-way handshake is complete) are placed on the queue `so_q`. The lengths of the queues are kept in `so_q0len` and `so_qlen`. Each queued connection is represented by its own socket. `so_head` in each queued socket points to the original socket with `SO_ACCEPTCONN` set.

The maximum number of queued connections for a particular socket is controlled by `so_qlimit`, which is specified by a process when it calls `listen`. The kernel silently enforces an upper limit of 5 (`SOMAXCONN`, Figure 15.24) and a lower limit of 0. A somewhat obscure formula shown with Figure 15.29 uses `so_qlimit` to control the number of queued connections.

Figure 15.8 illustrates a queue configuration in which three connections are ready to be accepted and one connection is being established.

65 `so_timeo` is a *wait channel* (Section 15.10) used during `accept`, `connect`, and `close` processing.

66 `so_error` holds an error code until it can be reported to a process during the next system call that references the socket.

67 If `SS_ASYNC` is set for a socket, the `SIGIO` signal is sent to the process (if `so_pgid` is greater than 0) or to the process group (if `so_pgid` is less than 0). `so_pgid` can be changed or examined with the `SIOCSPGRP` and `SIOCGPGRP` `ioctl` commands. For more information about process groups see [Stevens 1992].

68 `so_oobmark` identifies the point in the input data stream at which out-of-band data was most recently received. Section 16.11 discusses socket support for out-of-band data and Section 29.7 discusses the semantics of out-of-band data in TCP.

69-82 Each socket contains two data buffers, `so_rcv` and `so_snd`, used to buffer incoming and outgoing data. These are structures contained within the socket structure, not

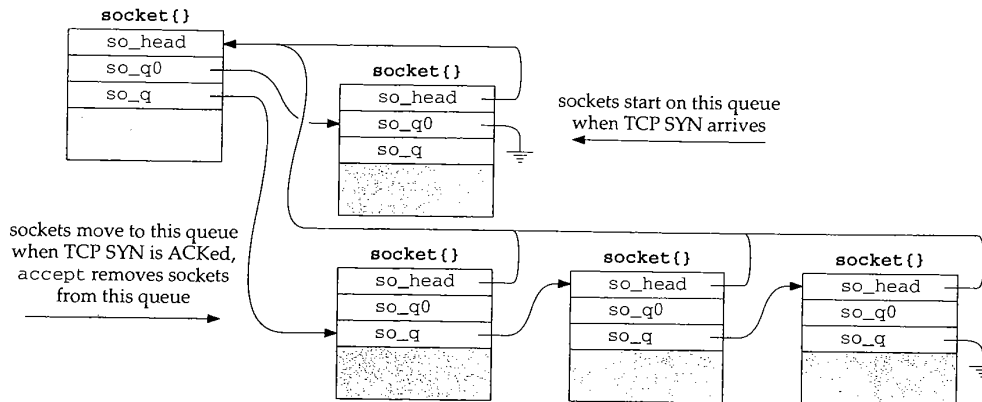

Figure 15.8 Socket connection queues.

pointers to structures. We describe the organization and use of the socket buffers in Chapter 16.

<sup>83-86</sup> `so_tpcb` is not used by Net/3. `so_upcall` and `so_upcallarg` are used only by the NFS software in Net/3.

NFS is unusual. In many ways it is a process-level application that has been moved into the kernel. The `so_upcall` mechanism triggers NFS input processing when data is added to a socket receive buffer. The `tsleep` and `wakeup` mechanism is inappropriate in this case, since the NFS protocol executes within the kernel, not as a process.

The files `socketvar.h` and `uipc_socket2.c` define several macros and functions that simplify the socket-layer code. Figure 15.9 summarizes them.

## 15.4 System Calls

A process interacts with the kernel through a collection of well-defined functions called *system calls*. Before showing the system calls that support networking, we discuss the system call mechanism itself.

The transfer of execution from a process to the protected environment of the kernel is machine- and implementation-dependent. In the discussion that follows, we use the 386 implementation of Net/3 to illustrate implementation specific operations.

In BSD kernels, each system call is numbered and the hardware is configured to transfer control to a single kernel function when the process executes a system call. The particular system call is identified as an integer argument to the function. In the 386 implementation, `syscall` is that function. Using the system call number, `syscall` indexes a table to locate the `sysent` structure for the requested system call. Each entry in the table is a `sysent` structure:

Name	Description
<code>sosendallatonce</code>	Does the protocol associated with <code>so</code> require each send system call to result in a single protocol request? <code>int sosendallatonce(struct socket *so);</code>
<code>soisconnecting</code>	Set the socket state to <code>SS_ISCONNECTING</code> . <code>int soisconnecting(struct socket *so);</code>
<code>soisconnected</code>	See Figure 15.30.
<code>soreadable</code>	Will a read on <code>so</code> return information without blocking? <code>int soreadable(struct socket *so);</code>
<code>sowriteable</code>	Will a write on <code>so</code> return without blocking? <code>int sowriteable(struct socket *so);</code>
<code>socantsendmore</code>	Set the <code>SS_CANTSENDMORE</code> flag. Wake up any processes sleeping on the send buffer. <code>int socantsendmore(struct socket *so);</code>
<code>socantrcvmore</code>	Set the <code>SS_CANTRCVMORE</code> flag. Wake up processes sleeping on the receive buffer. <code>int socantrcvmore(struct socket *so);</code>
<code>sodisconnect</code>	Issue the <code>PRU_DISCONNECT</code> request. <code>int sodisconnect(struct socket *so);</code>
<code>soisdisconnecting</code>	Clear the <code>SS_ISCONNECTING</code> flag. Set <code>SS_ISDISCONNECTING</code> , <code>SS_CANTRCVMORE</code> , and <code>SS_CANTSENDMORE</code> flags. Wake up any processes selecting on the socket. <code>int soisdisconnecting(struct socket *so);</code>
<code>soisdisconnected</code>	Clear the <code>SS_ISCONNECTING</code> , <code>SS_ISCONNECTED</code> , and <code>SS_ISDISCONNECTING</code> flags. Set the <code>SS_CANTRCVMORE</code> and <code>SS_CANTSENDMORE</code> flags. Wake up any processes selecting on the socket or waiting for close to complete. <code>int soisdisconnected(struct socket *so);</code>
<code>soqinsque</code>	Insert <code>so</code> on a queue associated with <code>head</code> . If <code>q</code> is 0, the socket is added to the end of <code>so_q0</code> , which holds incomplete connections. Otherwise, the socket is added to the end of <code>so_q</code> , which holds connections that are ready to be accepted. Net/1 incorrectly placed sockets at the front of the queue. <code>int soqinsque(struct socket *head, struct socket *so, int q);</code>
<code>soqremque</code>	Remove <code>so</code> from the queue identified by <code>q</code> . The socket queues are located by following <code>so-&gt;so_head</code> . <code>int soqremque(struct socket *so, int q);</code>

Figure 15.9 Socket macros and functions.

```

struct sysent {
    int sy_narg;          /* number of arguments */
    int (*sy_call) ();   /* implementing function */
};                       /* system call table entry */

```

Here are several entries from the `sysent` array, which is defined in `kern/init_sysent.c`.

```

struct sysent sysent[] = {
    /* ... */
    { 3, recvmsg },      /* 27 = recvmsg */
    { 3, sendmsg },     /* 28 = sendmsg */
    { 6, recvfrom },    /* 29 = recvfrom */
    { 3, accept },      /* 30 = accept */
    { 3, getpeername }, /* 31 = getpeername */
    { 3, getsockname }, /* 32 = getsockname */
    /* ... */
}

```

For example, the `recvmsg` system call is the 27th entry in the system call table, has three arguments, and is implemented by the `recvmsg` function in the kernel.

`syscall` copies the arguments from the calling process into the kernel and allocates an array to hold the results of the system call, which `syscall` returns to the process when the system call completes. `syscall` dispatches control to the kernel function associated with the system call. In the 386 implementation, this call looks like:

```

struct sysent *callp;
error = (*callp->sy_call)(p, args, rval);

```

where `callp` is a pointer to the relevant `sysent` structure, `p` is a pointer to the process table entry for the process that made the system call, `args` represents the arguments to the system call as an array of 32-bit words, and `rval` is an array of two 32-bit words to hold the return value of the system call. When we use the term *system call*, we mean the function within the kernel called by `syscall`, not the function within the process called by the application.

`syscall` expects the system call function (i.e., what `sy_call` points to) to return 0 if no errors occurred and a nonzero error code otherwise. If no error occurs, the kernel passes the values in `rval` back to the process as the return value of the system call (the one made by the application). If an error occurs, `syscall` ignores the values in `rval` and returns the error code to the process in a machine-dependent way so that the error is made available to the process in the external variable `errno`. The function called by the application returns -1 or a null pointer to indicate that `errno` should be examined.

The 386 implementation sets the carry bit to indicate that the value returned by `syscall` is an error code. The system call stub in the process stores the code in `errno` and returns -1 or a null pointer to the application. If the carry bit is not set, the value returned by `syscall` is returned by the stub.

To summarize, a function implementing a system call "returns" two values: one for the `syscall` function, and a second (found in `rval`) that `syscall` returns to the calling process when no error occurs.

**Example**

The prototype for the `socket` system call is:

```
int socket(int domain, int type, int protocol);
```

The prototype for the kernel function that implements the system call is

```
struct socket_args {
    int domain;
    int type;
    int protocol;
};
socket(struct proc *p, struct socket_args *uap, int *retval);
```

When an application calls `socket`, the process passes three separate integers to the kernel with the system call mechanism. `syscall` copies the arguments into an array of 32-bit values and passes a pointer to the array as the second argument to the kernel version of `socket`. The kernel version of `socket` treats the second argument as a pointer to an `socket_args` structure. Figure 15.10 illustrates this arrangement.

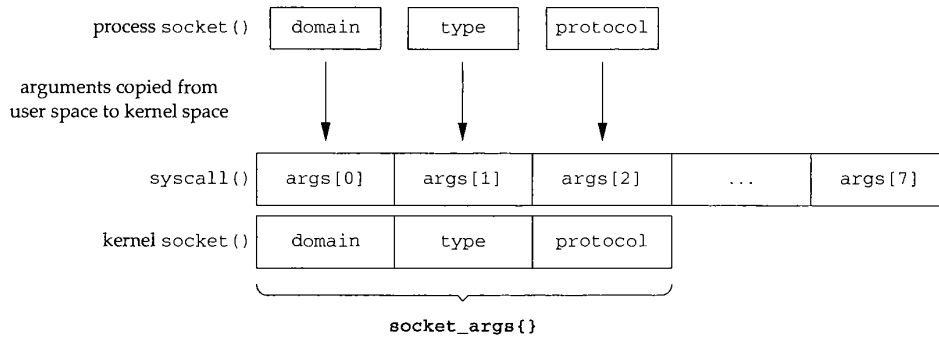

Figure 15.10 socket argument processing.

As illustrated by `socket`, each kernel function that implements a system call declares `args` not as a pointer to an array of 32-bit words, but as a pointer to a structure specific to the system call.

The implicit cast is legal only in traditional K&R C or in ANSI C when a prototype is not in effect. If a prototype is in effect, the compiler generates a warning.

`syscall` prepares the return value of 0 before executing the kernel system call function. If no error occurs, the system call function can return without clearing `*retval` and `syscall` returns 0 to the process.

**System Call Summary**

Figure 15.11 summarizes the system calls relevant to networking.



Category	Name	Function
setup	socket	create a new unnamed socket within a specified communication domain
	bind	assign a local address to a socket
server	listen	prepare a socket to accept incoming connections
	accept	wait for and accept connections
client	connect	establish a connection to a foreign socket
input	read	receive data into a single buffer
	readv	receive data into multiple buffers
	recv	receive data specifying options
	recvfrom	receive data and address of sender
	recvmsg	receive data into multiple buffers, control information, and receive the address of sender; specify receive options
output	write	send data from a single buffer
	writv	send data from multiple buffers
	send	send data specifying options
	sendto	send data to specified address
	sendmsg	send data from multiple buffers and control information to a specified address; specify send options
I/O	select	wait for I/O conditions
termination	shutdown	terminate connection in one or both directions
	close	terminate connection and release socket
administration	fcntl	modify I/O semantics
	ioctl	miscellaneous socket operations
	setsockopt	set socket or protocol options
	getsockopt	get socket or protocol options
	getsockname	get local address assigned to socket
	getpeername	get foreign address assigned to socket

Figure 15.11 Networking system calls in Net/3.

We present the setup, server, client, and termination calls in this chapter. The input and output system calls are discussed in Chapter 16 and the administrative calls in Chapter 17.

Figure 15.12 shows the sequence in which an application might use the calls. The I/O system calls in the large box can be called in any order. This is not a complete state diagram as some valid transitions are not included; just the most common ones are shown.

## 15.5 Processes, Descriptors, and Sockets

Before describing the socket system calls, we need to discuss the data structures that tie together processes, descriptors, and sockets. Figure 15.13 shows the structures and members relevant to our discussion. A more complete explanation of the file structures can be found in [Leffler et al. 1989].

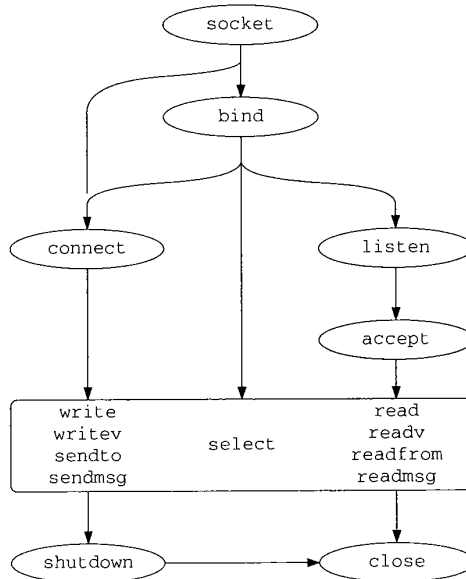

Figure 15.12 Network system call flowchart.

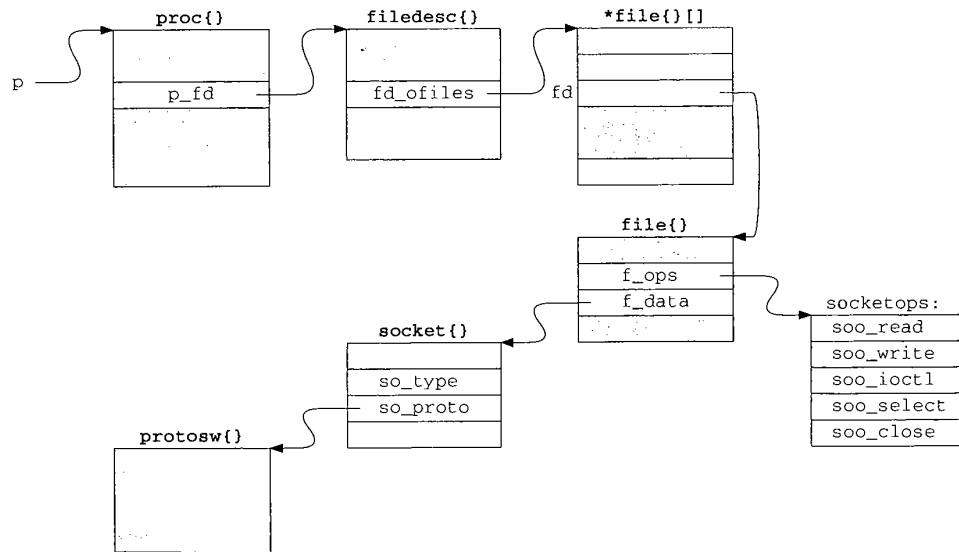

Figure 15.13 Process, file, and socket structures.

1

The first argument to a function implementing a system call is always *p*, a pointer to the *proc* structure of the calling process. The *proc* structure represents the kernel's notion of a process. Within the *proc* structure, *p\_fd* points to a *filedesc* structure, which manages the descriptor table pointed to by *fd\_ofiles*. The descriptor table is dynamically sized and consists of an array of pointers to file structures. Each file structure describes a single open file and can be shared between multiple processes.

Only a single file structure is shown in Figure 15.13. It is accessed by *p->p\_fd->fd\_ofiles[fd]*. Within the file structure, two members are of interest to us: *f\_ops* and *f\_data*. The implementation of I/O system calls such as *read* and *write* varies according to what type of I/O object is associated with a descriptor. *f\_ops* points to a *fileops* structure containing a list of function pointers that implement the *read*, *write*, *ioctl*, *select*, and *close* system calls for the associated I/O object. Figure 15.13 shows *f\_ops* pointing to a global *fileops* structure, *socketops*, which contains pointers to the functions for sockets.

*f\_data* points to private data used by the associated I/O object. For sockets, *f\_data* points to the *socket* structure associated with the descriptor. Finally, we see that *so\_proto* in the *socket* structure points to the *protosw* structure for the protocol selected when the socket is created. Recall that each *protosw* structure is shared by all sockets associated with the protocol.

We now proceed to discuss the system calls.

## 15.6 socket System Call

The *socket* system call creates a new socket and associates it with a protocol as specified by the *domain*, *type*, and *protocol* arguments specified by the process. The function (shown in Figure 15.14) allocates a new descriptor, which identifies the socket in future system calls, and returns the descriptor to the process.

42-55 Before each system call a structure is defined to describe the arguments passed from the process to the kernel. In this case, the arguments are passed within a *socket\_args* structure. All the socket-layer system calls have three arguments: *p*, a pointer to the *proc* structure for the calling process; *uap*, a pointer to a structure containing the arguments passed by the process to the system call; and *retval*, a value-result argument that points to the return value for the system call. Normally, we ignore the *p* and *retval* arguments and refer to the contents of the structure pointed to by *uap* as the arguments to the system call.

56-60 *falloc* allocates a new file structure and slot in the *fd\_ofiles* array (Figure 15.13). *fp* points to the new structure and *fd* is the index of the structure in the *fd\_ofiles* array. *socket* enables the file structure for read and write access and marks it as a socket. *socketops*, a global *fileops* structure shared by all sockets, is attached to the file structure by *f\_ops*. The *socketops* variable is initialized at compile time as shown in Figure 15.15.

60-69 *socreate* allocates and initializes a *socket* structure. If *socreate* fails, the error code is posted in *error*, the file structure is released, and the descriptor slot cleared. If *socreate* succeeds, *f\_data* is set to point to the *socket* structure and establishes

ops:
ad
ite
ctl
lect
lose

```

42 struct socket_args {
43     int     domain;
44     int     type;
45     int     protocol;
46 };
47 socket(p, uap, retval)
48 struct proc *p;
49 struct socket_args *uap;
50 int     *retval;
51 {
52     struct filedesc *fdp = p->p_fdp;
53     struct socket *so;
54     struct file *fp;
55     int     fd, error;
56     if (error = falloc(p, &fp, &fd))
57         return (error);
58     fp->f_flag = FREAD | FWRITE;
59     fp->f_type = DTYPE_SOCKET;
60     fp->f_ops = &socketops;
61     if (error = socreate(uap->domain, &so, uap->type, uap->protocol)) {
62         fdp->fd_ofiles[fd] = 0;
63         ffree(fp);
64     } else {
65         fp->f_data = (caddr_t) so;
66         *retval = fd;
67     }
68     return (error);
69 }

```

Figure 15.14 socket system call.

Member	Value
fo_read	soo_read
fo_write	soo_write
fo_ioctl	soo_ioctl
fo_select	soo_select
fo_close	soo_close

Figure 15.15 socketops: the global fileops structure for sockets.

the association between the descriptor and the socket. `fd` is returned to the process through `*retval`. `socket` returns 0 or the error code returned by `socreate`.

### socreate Function

Most socket system calls are divided into at least two functions, in the same way that `socket` and `socreate` are. The first function retrieves from the process all the data

alls.c

required, calls the second `socxx` function to do the work, and then returns any results to the process. This split is so that the second function can be called directly by kernel-based network protocols, such as NFS. `socreate` is shown in Figure 15.16.

```

43 socreate(dom, aso, type, proto)                                     uipc_socket.c
44 int     dom;
45 struct socket **aso;
46 int     type;
47 int     proto;
48 {
49     struct proc *p = curproc; /* XXX */
50     struct protosw *prp;
51     struct socket *so;
52     int     error;

53     if (proto)
54         prp = pffindproto(dom, proto, type);
55     else
56         prp = pffindtype(dom, type);
57     if (prp == 0 || prp->pr_usrreq == 0)
58         return (EPROTONOSUPPORT);
59     if (prp->pr_type != type)
60         return (EPROTOTYPE);
61     MALLOC(so, struct socket *, sizeof(*so), M_SOCKET, M_WAIT);
62     bzero((caddr_t) so, sizeof(*so));
63     so->so_type = type;
64     if (p->p_ucred->cr_uid == 0)
65         so->so_state = SS_PRIV;
66     so->so_proto = prp;
67     error =
68         (*prp->pr_usrreq) (so, PRU_ATTACH,
69             (struct mbuf *) 0, (struct mbuf *) proto, (struct mbuf *) 0);
70     if (error) {
71         so->so_state != SS_NOFDREF;
72         sofree(so);
73         return (error);
74     }
75     *aso = so;
76     return (0);
77 }

```

ills.c

uipc\_socket.c

Figure 15.16 `socreate` function.

43-52 The four arguments to `socreate` are: `dom`, the requested protocol domain (e.g., `PF_INET`); `aso`, in which a pointer to a new socket structure is returned; `type`, the requested socket type (e.g., `SOCK_STREAM`); and `proto`, the requested protocol.

#### Find protocol switch table

53-60 If `proto` is nonzero, `pffindproto` looks for the specific protocol requested by the process. If `proto` is 0, `pffindtype` looks for a protocol within the specified domain with the semantics specified by `type`. Both functions return a pointer to a `protosw` structure of the matching protocol or a null pointer (Section 7.6).

ress

hat  
ata

**Allocate and initialize socket structure**

61-66 `screate` allocates a new socket structure, fills it with 0s, records the type, and, if the calling process has superuser privileges, turns on `SS_PRIV` in the socket structure.

**PRU\_ATTACH request**

67-69 The first example of the protocol-independent socket layer making a protocol-specific request appears in `screate`. Recall from Section 7.4 and Figure 15.13 that `so->so_proto->pr_usrreq` is a pointer to the user-request function of the protocol associated with socket `so`. Every protocol provides this function in order to handle communication requests from the socket layer. The prototype for the function is:

```
int pr_usrreq(struct socket *so, int req, struct mbuf *m0, *m1, *m2);
```

The first argument, `so`, is a pointer to the relevant socket and `req` is a constant identifying the particular request. The next three arguments (`m0`, `m1`, and `m2`) are different for each request. They are always passed as pointers to `mbuf` structures, even if they have another type. Casts are used when necessary to avoid warnings from the compiler.

Figure 15.17 shows the requests available through the `pr_usrreq` function. The semantics of each request depend on the particular protocol servicing the request.

Request	Arguments			Description
	<i>m0</i>	<i>m1</i>	<i>m2</i>	
<code>PRU_ABORT</code>				abort any existing connection
<code>PRU_ACCEPT</code>		<i>address</i>		wait for and accept a connection
<code>PRU_ATTACH</code>		<i>protocol</i>		a new socket has been created
<code>PRU_BIND</code>		<i>address</i>		bind the address to the socket
<code>PRU_CONNECT</code>		<i>address</i>		establish association or connection to address
<code>PRU_CONNECT2</code>		<i>socket2</i>		connect two sockets together
<code>PRU_DETACH</code>				socket is being closed
<code>PRU_DISCONNECT</code>				break association between socket and foreign address
<code>PRU_LISTEN</code>				begin listening for connections
<code>PRU_PEERADDR</code>		<i>buffer</i>		return foreign address associated with socket
<code>PRU_RCVD</code>		<i>flags</i>		process has accepted some data
<code>PRU_RCVOOB</code>	<i>buffer</i>	<i>flags</i>		receive OOB data
<code>PRU_SEND</code>	<i>data</i>	<i>address</i>	<i>control</i>	send regular data
<code>PRU_SENDOOB</code>	<i>data</i>	<i>address</i>	<i>control</i>	send OOB data
<code>PRU_SHUTDOWN</code>				end communication with foreign address
<code>PRU_SOCKADDR</code>		<i>buffer</i>		return local address associated with socket

Figure 15.17 `pr_usrreq` requests.

`PRU_CONNECT2` is supported only within the Unix domain, where it connects two local sockets to each other. Unix pipes are implemented in this way.

**Cleanup and return**

70-77 Returning to `screate`, the function attaches the protocol switch table to the new socket and issues the `PRU_ATTACH` request to notify the protocol of the new end point. This request causes most protocols, including TCP and UDP, to allocate and initialize any structures required to support the new end point.

## Superuser Privileges

Figure 15.18 summarizes the networking operations that require superuser access.

Function	Superuser		Description	Reference
	Process	Socket		
in_control		•	interface address, netmask, and destination address assignment	Figure 6.14
in_control		•	broadcast address assignment	Figure 6.22
in_pcbbind	•		binding to an Internet port less than 1024	Figure 22.22
ifioctl	•		interface configuration changes	Figure 4.29
ifioctl	•		multicast address configuration (see text)	Figure 12.11
rip_usrreq	•		creating an ICMP, IGMP, or raw IP socket	Figure 32.10
slopen	•		associating a SLIP device with a tty device	Figure 5.9

Figure 15.18 Superuser privileges in Net/3.

The multicast `ioctl` commands (`SIOCADDMULTI` and `SIOCDELMULTI`) are accessible to non-superuser processes when they are invoked indirectly by the `IP_ADD_MEMBERSHIP` and `IP_DROP_MEMBERSHIP` socket options (Sections 12.11 and 12.12).

In Figure 15.18, the "Process" column identifies requests that must be made by a superuser process, and the "Socket" column identifies requests that must be issued on a socket *created* by a superuser process (i.e., the process does not need superuser privileges if it has access to the socket, Exercise 15.1). In Net/3, the `suser` function determines if the calling process has superuser privileges, and the `SS_PRIV` flag determines if the socket was created by a superuser process.

Since `rip_usrreq` tests `SS_PRIV` immediately after creating the socket with `socreate`, we show this function as accessible only from a superuser process.

## 15.7 getsock and sockargs Functions

These functions appear repeatedly in the implementation of the socket system calls. `getsock` maps a descriptor to a file table entry and `sockargs` copies arguments from the process to a newly allocated mbuf in the kernel. Both functions check for invalid arguments and return a nonzero error code accordingly.

Figure 15.19 shows the `getsock` function.

754-767 The function selects the file table entry specified by the descriptor `fdes` with `fdp`, a pointer to the `filedesc` structure. `getsock` returns a pointer to the open file structure in `fpp` or an error if the descriptor is out of the valid range, does not point to an open file, or does not have a socket associated with it.

Figure 15.20 shows the `sockargs` function.

768-783 The mechanism described in Section 15.4 copies pointer arguments for a system call from the process to the kernel but does not copy the data referenced by the pointers, since the semantics of each argument are known only by the specific system call and not

```

754 getsock(fdp, fdes, fpp)
755 struct filedesc *fdp;
756 int    fdes;
757 struct file **fpp;
758 {
759     struct file *fp;
760     if ((unsigned) fdes >= fdp->fd_nfiles ||
761         (fp = fdp->fd_ofiles[fdes]) == NULL)
762         return (EBADF);
763     if (fp->f_type != DTYPE_SOCKET)
764         return (ENOTSOCK);
765     *fpp = fp;
766     return (0);
767 }

```

Figure 15.19 getsock function.

```

768 sockargs(mp, buf, buflen, type)
769 struct mbuf **mp;
770 caddr_t buf;
771 int    buflen, type;
772 {
773     struct sockaddr *sa;
774     struct mbuf *m;
775     int    error;
776     if ((u_int) buflen > MLEN) {
777         return (EINVAL);
778     }
779     m = m_get(M_WAIT, type);
780     if (m == NULL)
781         return (ENOBUFS);
782     m->m_len = buflen;
783     error = copyin(buf, mtod(m, caddr_t), (u_int) buflen);
784     if (error)
785         (void) m_free(m);
786     else {
787         *mp = m;
788         if (type == MT_SONAME) {
789             sa = mtod(m, struct sockaddr *);
790             sa->sa_len = buflen;
791         }
792     }
793     return (error);
794 }

```

Figure 15.20 sockargs function.

by the generic system call mechanism. Several system calls use `sockargs` to follow the pointer arguments and copy the referenced data from the process into a newly allocated `mbuf` within the kernel. For example, `sockargs` copies the local socket address pointed to by `bind`'s second argument from the process to an `mbuf`.



If the data does not fit in a single mbuf or an mbuf cannot be allocated, `sockargs` returns `EINVAL` or `ENOBUFS`. Note that a standard mbuf is used and not a packet header mbuf. `copyin` copies the data from the process into the mbuf. The most common error from `copyin` is `EACCES`, returned when the process provides an invalid address.

784-785 When an error occurs, the mbuf is discarded and the error code is returned. If there is no error, a pointer to the mbuf is returned in `mp`, and `sockargs` returns 0.

786-794 If `type` is `MT_SONAME`, the process is passing in a `sockaddr` structure. `sockargs` sets the internal length, `sa_len`, to the length of the argument just copied. This ensures that the size contained within the structure is correct even if the process did not initialize the structure correctly.

Net/3 does include code to support applications compiled on a pre-4.3BSD Reno system, which did not have an `sa_len` member in the `sockaddr` structure, but that code is not shown in Figure 15.20.

## 15.8 bind System Call

The `bind` system call associates a local network transport address with a socket. A process acting as a client usually does not care what its local address is. In this case, it isn't necessary to call `bind` before the process attempts to communicate; the kernel selects and implicitly binds a local address to the socket as needed.

A server process almost always needs to bind to a specific well-known address. If so, the process must call `bind` before accepting connections (TCP) or receiving datagrams (UDP), because the clients establish connections or send datagrams to the well-known address.

A socket's foreign address is specified by `connect` or by one of the write calls that allow specification of foreign addresses (`sendto` or `sendmsg`).

Figure 15.21 shows `bind`.

70-82 The arguments to `bind` (passed within a `bind_args` structure) are: `s`, the socket descriptor; `name`, a pointer to a buffer containing the transport address (e.g., a `sockaddr_in` structure); and `namelen`, the size of the buffer.

83-90 `getsock` returns the file structure for the descriptor, and `sockargs` copies the local address from the process into an mbuf, `sobind` associates the address specified by the process with the socket. Before `bind` returns `sobind`'s result, the mbuf holding the address is released.

Technically, a descriptor such as `s` identifies a file structure with an associated socket structure and is not itself a socket structure. We refer to such a descriptor as a socket to simplify our discussion.

We will see this pattern many times: arguments specified by the process are copied into an mbuf and processed as necessary, and then the mbuf is released before the system call returns. Although mbufs were designed explicitly to facilitate processing of network data packets, they are also effective as a general-purpose dynamic memory allocation mechanism.

```

-----uipc_syscalls.c
70 struct bind_args {
71     int     s;
72     caddr_t name;
73     int     namelen;
74 };

75 bind(p, uap, retval)
76 struct proc *p;
77 struct bind_args *uap;
78 int     *retval;
79 {
80     struct file *fp;
81     struct mbuf *nam;
82     int     error;

83     if (error = getsock(p->p_fd, uap->s, &fp))
84         return (error);
85     if (error = sockargs(&nam, uap->name, uap->namelen, MT_SONAME))
86         return (error);
87     error = sobind((struct socket *) fp->f_data, nam);
88     m_freem(nam);
89     return (error);
90 }
-----uipc_syscalls.c

```

Figure 15.21 bind function.

Another pattern illustrated by `bind` is that `retval` is unused in many system calls. In Section 15.4 we mentioned that `retval` is always initialized to 0 before `syscall` dispatches control to a system call. If 0 is the appropriate return value, the system calls do not need to change `retval`.

### sobind Function

`sobind`, shown in Figure 15.22, is a wrapper that issues the `PRU_BIND` request to the protocol associated with the socket.

```

-----uipc_socket.c
78 sobind(so, nam)
79 struct socket *so;
80 struct mbuf *nam;
81 {
82     int     s = splnet();
83     int     error;

84     error =
85         (*so->so_proto->pr_usrreq) (so, PRU_BIND,
86                                     (struct mbuf *) 0, nam, (struct mbuf *) 0);
87     splx(s);
88     return (error);
89 }
-----uipc_socket.c

```

Figure 15.22 sobind function.

s.c

78-89 `sobind` issues the `PRU_BIND` request. The local address, `nam`, is associated with the socket if the request succeeds; otherwise the error code is returned.

## 15.9 listen System Call

The `listen` system call, shown in Figure 15.23, notifies a protocol that the process is prepared to accept incoming connections on the socket. It also specifies a limit on the number of connections that can be queued on the socket, after which the socket layer refuses to queue additional connection requests. When this occurs, TCP ignores incoming connection requests. Queued connections are made available to the process when it calls `accept` (Section 15.11).

s.c

lls.

.ll

alls

```

91 struct listen_args {
92     int     s;
93     int     backlog;
94 };

95 listen(p, uap, retval)
96 struct proc *p;
97 struct listen_args *uap;
98 int     *retval;
99 {
100     struct file *fp;
101     int     error;

102     if (error = getsock(p->p_fd, uap->s, &fp))
103         return (error);
104     return (solisten((struct socket *) fp->f_data, uap->backlog));
105 }

```

*uipc\_syscalls.c*

*uipc\_syscalls.c*

Figure 15.23 listen system call.

the

z.t.c

91-98 The two arguments passed to `listen` specify the socket descriptor and the connection queue limit.

99-105 `getsock` returns the file structure for the descriptor, `s`, and `solisten` passes the listen request to the protocol layer.

### `solisten` Function

This function, shown in Figure 15.24, issues the `PRU_LISTEN` request and prepares the socket to receive connections.

90-109 After `solisten` issues the `PRU_LISTEN` request and `pr_usrreq` returns, the socket is marked as ready to accept connections. `SS_ACCEPTCONN` is not set if a connection is queued when `pr_usrreq` returns.

ket.c

The maximum queue size for incoming connections is computed and saved in `so_qlimit`. Here Net/3 silently enforces a lower limit of 0 and an upper limit of 5 (`SOMAXCONN`) backlogged connections.

```

90 solisten(so, backlog)
91 struct socket *so;
92 int backlog;
93 {
94     int s = splnet(), error;
95     error =
96         (*so->so_proto->pr_usrreq) (so, PRU_LISTEN,
97             (struct mbuf *) 0, (struct mbuf *) 0, (struct mbuf *) 0);
98     if (error) {
99         splx(s);
100        return (error);
101    }
102    if (so->so_q == 0)
103        so->so_options |= SO_ACCEPTCONN;
104    if (backlog < 0)
105        backlog = 0;
106    so->so_qlimit = min(backlog, SOMAXCONN);
107    splx(s);
108    return (0);
109 }

```

uipc\_socket.c

uipc\_socket.c

Figure 15.24 solisten function.

## 15.10 tsleep and wakeup Functions

When a process executing within the kernel cannot proceed because a kernel resource is unavailable, it waits for the resource by calling `tsleep`, which has the following prototype:

```
int tsleep(caddr_t chan, int pri, char *mesg, int timeo);
```

The first argument to `tsleep`, `chan`, is called the *wait channel*. It identifies the particular resource or event such as an incoming network connection, for which the process is waiting. Many processes can be sleeping on a single wait channel. When the resource becomes available or when the event occurs, the kernel calls `wakeup` with the wait channel as the single argument. The prototype for `wakeup` is:

```
void wakeup(caddr_t chan);
```

All processes waiting for the channel are awakened and set to the run state. The kernel arranges for `tsleep` to return when each of the processes resumes execution.

The `pri` argument specifies the priority of the process when it is awakened, as well as several optional control flags for `tsleep`. By setting the `PCATCH` flag in `pri`, `tsleep` also returns when a signal arrives. `mesg` is a string identifying the call to `tsleep` and is included in debugging messages and in `ps` output. `timeo` sets an upper bound on the sleep period and is measured in clock ticks.

Figure 15.25 summarizes the return values from `tsleep`.

A process never sees the `ERESTART` error because it is handled by the `syscall` function and never returned to a process.

tsleep()	Description
0	The process was awakened by a matching call to wakeup.
EWOULDBLOCK	The process was awakened after sleeping for <i>timeo</i> clock ticks and before the matching call to wakeup.
ERESTART	A signal was handled by the process during the sleep and the pending system call should be restarted.
EINTR	A signal was handled by the process during the sleep and the pending system call should fail.

Figure 15.25 tsleep return values.

Because all processes sleeping on a wait channel are awakened by wakeup, we always see a call to `tsleep` within a tight loop. Every process must determine if the resource is available before proceeding because another awakened process may have claimed the resource first. If the resource is not available, the process calls `tsleep` once again.

It is unusual for multiple processes to be sleeping on a single socket, so a call to wakeup usually causes only one process to be awakened by the kernel.

For a more detailed discussion of the sleep and wakeup mechanism see [Leffler et al. 1989].

### Example

One use of multiple processes sleeping on the same wait channel is to have multiple server processes reading from a UDP socket. Each server calls `recvfrom` and, as long as no data is available, the calls block in `tsleep`. When a datagram arrives on the socket, the socket layer calls `wakeup` and each server is placed on the run queue. The first server to run receives the datagram while the others call `tsleep` again. In this way, incoming datagrams are distributed to multiple servers without the cost of starting a new process for each datagram. This technique can also be used to process incoming connection requests in TCP by having multiple processes call `accept` on the same socket. This technique is described in [Comer and Stevens 1993].

## 15.11 accept System Call

After calling `listen`, a process waits for incoming connections by calling `accept`, which returns a descriptor that references a new socket connected to a client. The original socket, `s`, remains unconnected and ready to receive additional connections. `accept` returns the address of the foreign system if `name` points to a valid buffer.

The connection-processing details are handled by the protocol associated with the socket. For TCP, the socket layer is notified when a connection has been established (i.e., when TCP's three-way handshake has completed). For other protocols, such as OSI's TP4, `tsleep` returns when a connection request has arrived. The connection is completed when explicitly confirmed by the process by reading or writing on the socket.

Figure 15.26 shows the implementation of `accept`.

```

106 struct accept_args {
107     int     s;
108     caddr_t name;
109     int     *anamelen;
110 };

111 accept(p, uap, retval)
112 struct proc *p;
113 struct accept_args *uap;
114 int     *retval;
115 {
116     struct file *fp;
117     struct mbuf *nam;
118     int     namelen, error, s;
119     struct socket *so;

120     if (uap->name && (error = copyin((caddr_t) uap->anamelen,
121                                     (caddr_t) & namelen, sizeof(namelen))))
122         return (error);
123     if (error = getsock(p->p_fd, uap->s, &fp))
124         return (error);
125     s = splnet();
126     so = (struct socket *) fp->f_data;
127     if ((so->so_options & SO_ACCEPTCONN) == 0) {
128         splx(s);
129         return (EINVAL);
130     }
131     if ((so->so_state & SS_NBIO) && so->so_qlen == 0) {
132         splx(s);
133         return (EWOULDBLOCK);
134     }
135     while (so->so_qlen == 0 && so->so_error == 0) {
136         if (so->so_state & SS_CANTRCVMORE) {
137             so->so_error = ECONNABORTED;
138             break;
139         }
140         if (error = tsleep((caddr_t) & so->so_timeo, PSOCK | PCATCH,
141                             netcon, 0)) {
142             splx(s);
143             return (error);
144         }
145     }
146     if (so->so_error) {
147         error = so->so_error;
148         so->so_error = 0;
149         splx(s);
150         return (error);
151     }
152     if (error = falloc(p, &fp, retval)) {
153         splx(s);
154         return (error);
155     }
}

```

*uipc\_syscalls.c*

```

156     { struct socket *aso = so->so_q;
157       if (sogremque(aso, 1) == 0)
158         panic("accept");
159       so = aso;
160     }

161     fp->f_type = DTYPE_SOCKET;
162     fp->f_flag = FREAD | FWRITE;
163     fp->f_ops = &socketops;
164     fp->f_data = (caddr_t) so;
165     nam = m_get(M_WAIT, MT_SONAME);
166     (void) soaccept(so, nam);
167     if (uap->name) {
168       if (namelen > nam->m_len)
169         namelen = nam->m_len;
170       /* SHOULD COPY OUT A CHAIN HERE */
171       if ((error = copyout(mtod(nam, caddr_t), (caddr_t) uap->name,
172                           (u_int) namelen)) == 0)
173         error = copyout((caddr_t) &namelen,
174                        (caddr_t) uap->anamelen, sizeof(*uap->anamelen));
175     }
176     m_freem(nam);
177     splx(s);
178     return (error);
179 }

```

*uipc\_syscalls.c*

Figure 15.26 accept system call.

106-114 The three arguments to `accept` (in the `accept_args` structure) are: `s`, the socket descriptor; `name`, a pointer to a buffer to be filled in by `accept` with the transport address of the foreign host; and `anamelen`, a pointer to the size of the buffer.

#### Validate arguments

116-134 `accept` copies the size of the buffer (`*anamelen`) into `namelen`, and `getsock` returns the file structure for the socket. If the socket is not ready to accept connections (i.e., `listen` has not been called) or nonblocking I/O has been requested and no connections are queued, `EINVAL` or `EWOULDBLOCK` are returned respectively.

#### Wait for a connection

135-145 The while loop continues until a connection is available, an error occurs, or the socket can no longer receive data. `accept` is not automatically restarted after a signal is caught (`tsleep` returns `EINTR`). The protocol layer wakes up the process when it inserts a new connection on the queue with `sonewconn`.

Within the loop, the process waits in `tsleep`, which returns 0 when a connection is available. If `tsleep` is interrupted by a signal or the socket is set for nonblocking semantics, `accept` returns `EINTR` or `EWOULDBLOCK` (Figure 15.25).

#### Asynchronous errors

146-151 If an error occurred on the socket during the sleep, the error code is moved from the socket to the return value for `accept`, the socket error is cleared, and `accept` returns.

It is common for asynchronous events to change the state of a socket. The protocol processing layer notifies the socket layer of the change by setting `so_error` and waking any process waiting on the socket. Because of this, the socket layer must always examine `so_error` after waking to see if an error occurred while the process was sleeping.

#### Associate socket with descriptor

152-164 `falloc` allocates a descriptor for the new connection; the socket is removed from the accept queue by `soqremque` and attached to the `file` structure. Exercise 15.4 discusses the call to `panic`.

#### Protocol processing

167-179 `accept` allocates a new mbuf to hold the foreign address and calls `soaccept` to do protocol processing. The allocation and queueing of new sockets created during connection processing is described in Section 15.12. If the process provided a buffer to receive the foreign address, `copyout` copies the address from `nam` and the length from `namelen` to the process. If necessary, `copyout` silently truncates the name to fit in the process's buffer. Finally, the mbuf is released, protocol processing enabled, and `accept` returns.

Because only one mbuf is allocated for the foreign address, transport addresses must fit in one mbuf. Unix domain addresses, which are pathnames in the filesystem (up to 1023 bytes in length), may encounter this limit, but there is no problem with the 16-byte `sockaddr_in` structure for the Internet domain. The comment on line 170 indicates that this limitation could be removed by allocating and copying an mbuf chain.

### soaccept Function

`soaccept`, shown in Figure 15.27, calls the protocol layer to retrieve the client's address for the new connection.

```

184 soaccept(so, nam)
185 struct socket *so;
186 struct mbuf *nam;
187 {
188     int    s = splnet();
189     int    error;

190     if ((so->so_state & SS_NOFDREF) == 0)
191         panic("soaccept: !NOFDREF");
192     so->so_state &= ~SS_NOFDREF;
193     error = (*so->so_proto->pr_usrreq) (so, PRU_ACCEPT,
194                                     (struct mbuf *) 0, nam, (struct mbuf *) 0);
195     splx(s);
196     return (error);
197 }

```

*uipc\_socket.c*

*uipc\_socket.c*

Figure 15.27 `soaccept` function.



184-197 `soaccept` ensures that the socket is associated with a descriptor and issues the `PRU_ACCEPT` request to the protocol. After `pr_usrreq` returns, `nam` contains the name of the foreign socket.

### 15.12 sonewconn and soisconnected Functions

In Figure 15.26 we saw that `accept` waits for the protocol layer to process incoming connection requests and to make them available through `so_q`. Figure 15.28 uses TCP to illustrate this process.

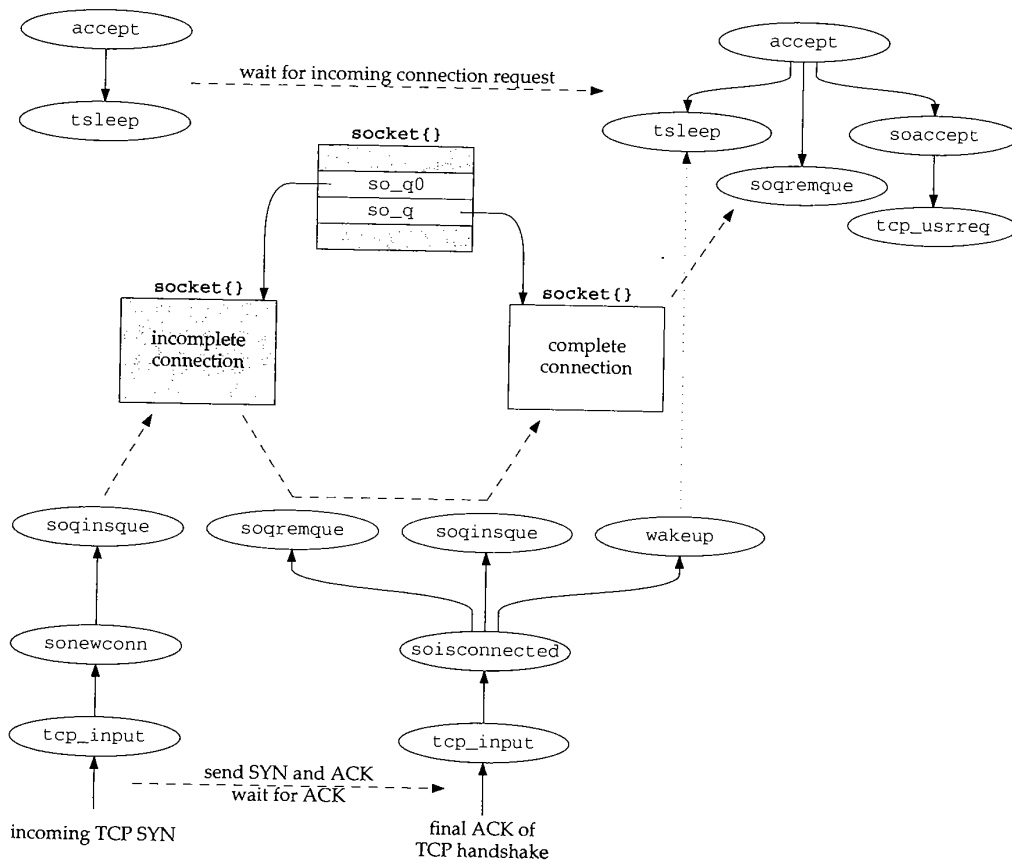

Figure 15.28 Incoming TCP connection processing.

In the upper left corner of Figure 15.28, `accept` calls `tsleep` to wait for incoming connections. In the lower left, `tcp_input` processes an incoming TCP SYN by calling `sonewconn` to create a socket for the new connection (Figure 28.7). `sonewconn` queues the socket on `so_q0`, since the three-way handshake is not yet complete.

When the final ACK of the TCP handshake arrives, `tcp_input` calls `soisconnected` (Figure 29.2), which updates the new socket, moves it from `so_q0` to `so_q`, and wakes up any processes that had called `accept` to wait for incoming connections.

The upper right corner of the figure shows the functions we described with Figure 15.26. When `tsleep` returns, `accept` takes the connection off `so_q` and issues the `PRU_ATTACH` request. The socket is associated with a new file descriptor and returned to the calling process.

Figure 15.29 shows the `sonewconn` function.

```

123 struct socket *
124 sonewconn(head, connstatus)
125 struct socket *head;
126 int connstatus;
127 {
128     struct socket *so;
129     int soqueue = connstatus ? 1 : 0;
130
131     if (head->so_qlen + head->so_q0len > 3 * head->so_qlimit / 2)
132         return ((struct socket *) 0);
133     MALLOC(so, struct socket *, sizeof(*so), M_SOCKET, M_DONTWAIT);
134     if (so == NULL)
135         return ((struct socket *) 0);
136     bzero((caddr_t) so, sizeof(*so));
137     so->so_type = head->so_type;
138     so->so_options = head->so_options & ~SO_ACCEPTCONN;
139     so->so_linger = head->so_linger;
140     so->so_state = head->so_state | SS_NOFDREF;
141     so->so_proto = head->so_proto;
142     so->so_timeo = head->so_timeo;
143     so->so_pgid = head->so_pgid;
144     (void) soreserve(so, head->so_snd.sb_hiwat, head->so_rcv.sb_hiwat);
145     soqinsque(head, so, soqueue);
146     if ((*so->so_proto->pr_usrreq) (so, PRU_ATTACH,
147         (struct mbuf *) 0, (struct mbuf *) 0, (struct mbuf *) 0)) {
148         (void) soqremque(so, soqueue);
149         (void) free((caddr_t) so, M_SOCKET);
150         return ((struct socket *) 0);
151     }
152     if (connstatus) {
153         sorwakeup(head);
154         wakeup((caddr_t) & head->so_timeo);
155         so->so_state != connstatus;
156     }
157     return (so);
158 }

```

Figure 15.29 `sonewconn` function.

123-129 The protocol layer passes `head`, a pointer to the socket that is accepting the incoming connection, and `connstatus`, a flag to indicate the state of the new connection. For TCP, `connstatus` is always 0.

For TP4, `connstatus` is always `SS_ISCONFIRMING`. The connection is implicitly confirmed when a process begins reading from or writing to the socket.

### Limit incoming connections

130-131 `sonewconn` prohibits additional connections when the following inequality is true:

$$\text{so\_qlen} + \text{so\_q0len} > \frac{3 \times \text{so\_qlimit}}{2}$$

This formula provides a fudge factor for connections that never complete and guarantees that `listen(fd, 0)` allows one connection. See Figure 18.23 in Volume 1 for an additional discussion of this formula.

### Allocate new socket

132-143 A new socket structure is allocated and initialized. If the process calls `setsockopt` for the listening socket, the connected socket inherits several socket options because `so_options`, `so_linger`, `so_pgid`, and the `sb_hiwat` values are copied into the new socket structure.

### Queue connection

144 `soqueue` was set from `connstatus` on line 129. The new socket is inserted onto `so_q0` if `soqueue` is 0 (e.g., TCP connections) or onto `so_q` if `connstatus` is nonzero (e.g., TP4 connections).

### Protocol processing

145-150 The `PRU_ATTACH` request is issued to perform protocol layer processing on the new connection. If this fails, the socket is dequeued and discarded, and `sonewconn` returns a null pointer.

### Wakeup processes

151-157 If `connstatus` is nonzero, any processes sleeping in `accept` or selecting for readability on the socket are awakened. `connstatus` is logically ORed with `so_state`. This code is never executed for TCP connections, since `connstatus` is always 0 for TCP.

Protocols, such as TCP, that put incoming connections on `so_q0` first, call `soisconnected` when the connection establishment phase completes. For TCP, this happens when the second SYN is ACKed on the connection.

Figure 15.30 shows `soisconnected`.

### Queue incomplete connections

78-87 The socket state is changed to show that the connection has completed. When `soisconnected` is called for incoming connections, (i.e., when the local process is calling `accept`), `head` is nonnull.

If `soqremque` returns 1, the socket is queued on `so_q` and `soawakeup` wakes up any processes using `select` to monitor the socket for connection arrival by testing for readability. If a process is blocked in `accept` waiting for the connection, `wakeup` causes the matching `tsleep` to return.

```

78 soisconnected(so)
79 struct socket *so;
80 {
81     struct socket *head = so->so_head;
82     so->so_state &= ~(SS_ISCONNECTING | SS_ISDISCONNECTING | SS_ISCONFIRMING);
83     so->so_state |= SS_ISCONNECTED;
84     if (head && soqremque(so, 0)) {
85         soqinsque(head, so, 1);
86         sorwakeup(head);
87         wakeup((caddr_t) & head->so_timeo);
88     } else {
89         wakeup((caddr_t) & so->so_timeo);
90         sorwakeup(so);
91         sowwakeup(so);
92     }
93 }

```

Figure 15.30 soisconnected function.

#### Wakeup processes waiting for new connection

88-93 If head is null, soqremque is not called since the process initiated the connection with the connect system call and the socket is not on a queue. If head is nonnull and soqremque returns 0, the socket is already on so\_q. This happens with protocols such as TP4, which place connections on so\_q before they are complete. wakeup awakens any process blocked in connect, and sorwakeup and sowwakeup take care of any processes that are using select to wait for the connection to complete.

### 15.13 connect System call

A server process calls the listen and accept system calls to wait for a remote process to initiate a connection. If the process wants to initiate a connection itself (i.e., a client), it calls connect.

For connection-oriented protocols such as TCP, connect establishes a connection to the specified foreign address. The kernel selects and implicitly binds an address to the local socket if the process has not already done so with bind.

For connectionless protocols such as UDP or ICMP, connect records the foreign address for use in sending future datagrams. Any previous foreign address is replaced with the new address.

Figure 15.31 shows the functions called when connect is used for UDP or TCP.

The left side of the figure shows connect processing for connectionless protocols, such as UDP. In this case the protocol layer calls soisconnected and the connect system call returns immediately.

The right side of the figure shows connect processing for connection-oriented protocols, such as TCP. In this case, the protocol layer begins the connection establishment and calls soisconnecting to indicate that the connection will complete some time in the future. Unless the socket is nonblocking, soconnect calls tsleep to wait for the

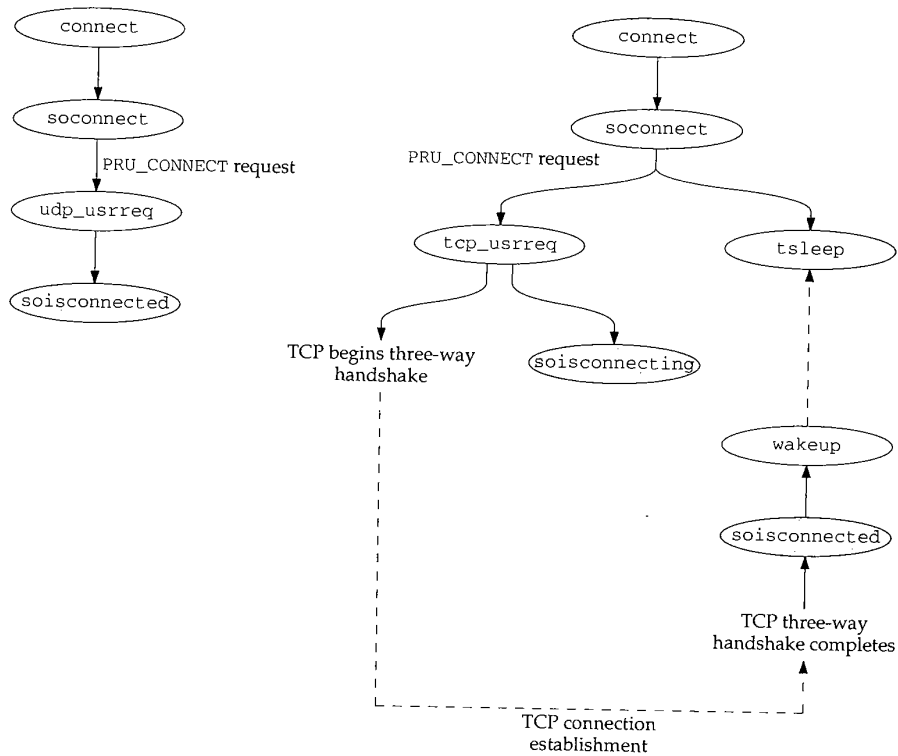

Figure 15.31 connect processing.

connection to complete. For TCP, when the three-way handshake is complete, the protocol layer calls `soisconnected` to mark the socket as connected and then calls `wakeup` to awaken the process and complete the `connect` system call.

Figure 15.32 shows the `connect` system call.

180-188 The three arguments to `connect` (in the `connect_args` structure) are: `s`, the socket descriptor; `name`, a pointer to a buffer containing the foreign address; and `namelen`, the length of the buffer.

189-200 `getsock` returns the socket as usual. A connection request may already be pending on a nonblocking socket, in which case `EALREADY` is returned. `sockargs` copies the foreign address from the process into the kernel.

#### Start connection processing

201-208 The connection attempt is started by calling `soconnect`. If `soconnect` reports an error, `connect` jumps to `bad`. If a connection has not yet completed by the time `soconnect` returns and nonblocking I/O is enabled, `EINPROGRESS` is returned immediately to avoid waiting for the connection to complete. Since connection establishment

```

180 struct connect_args {
181     int     s;
182     caddr_t name;
183     int     namelen;
184 };

185 connect(p, uap, retval)
186 struct proc *p;
187 struct connect_args *uap;
188 int     *retval;
189 {
190     struct file *fp;
191     struct socket *so;
192     struct mbuf *nam;
193     int     error, s;

194     if (error = getsock(p->p_fd, uap->s, &fp))
195         return (error);
196     so = (struct socket *) fp->f_data;
197     if ((so->so_state & SS_NBIO) && (so->so_state & SS_ISCONNECTING))
198         return (EALREADY);
199     if (error = sockargs(&nam, uap->name, uap->namelen, MT_SONAME))
200         return (error);

201     error = soconnect(so, nam);
202     if (error)
203         goto bad;
204     if ((so->so_state & SS_NBIO) && (so->so_state & SS_ISCONNECTING)) {
205         m_freem(nam);
206         return (EINPROGRESS);
207     }
208     s = splnet();
209     while ((so->so_state & SS_ISCONNECTING) && so->so_error == 0)
210         if (error = tsleep((caddr_t) & so->so_timeo, PSOCK | PCATCH,
211             netcon, 0))
212             break;
213     if (error == 0) {
214         error = so->so_error;
215         so->so_error = 0;
216     }
217     splx(s);
218 bad:
219     so->so_state &= ~SS_ISCONNECTING;
220     m_freem(nam);
221     if (error == ERESTART)
222         error = EINTR;
223     return (error);
224 }

```

Figure 15.32 connect system call.

alls.c

normally involves exchanging several packets with the remote system, it may take a while to complete. Further calls to `connect` return `EALREADY` until the connection completes. `EISCONN` is returned when the connection is complete.

#### Wait for connection establishment

208-217 The while loop continues until the connection is established or an error occurs. `splnet` prevents `connect` from missing a wakeup between testing the state of the socket and the call to `tsleep`. After the loop, `error` contains 0, the error code from `tsleep`, or the error from the socket.

218-224 The `SS_ISCONNECTING` flag is cleared since the connection has completed or the attempt has failed. The mbuf containing the foreign address is released and any error is returned.

#### soconnect Function

This function ensures that the socket is in a valid state for a connection request. If the socket is not connected or a connection is not pending, then the connection request is always valid. If the socket is already connected or a connection is pending, the new connection request is rejected for connection-oriented protocols such as TCP. For connectionless protocols such as UDP, multiple connection requests are OK but each new request replaces the previous foreign address.

Figure 15.33 shows the `soconnect` function.

```

198 soconnect(so, nam)
199 struct socket *so;
200 struct mbuf *nam;
201 {
202     int     s;
203     int     error;
204
205     if (so->so_options & SO_ACCEPTCONN)
206         return (EOPNOTSUPP);
207     s = splnet();
208     /*
209      * If protocol is connection-based, can only connect once.
210      * Otherwise, if connected, try to disconnect first.
211      * This allows user to disconnect by connecting to, e.g.,
212      * a null address.
213      */
214     if (so->so_state & (SS_ISCONNECTED | SS_ISCONNECTING) &&
215         ((so->so_proto->pr_flags & PR_CONNREQUIRED) ||
216          (error = sodisconnect(so))))
217         error = EISCONN;
218     else
219         error = (*so->so_proto->pr_usrreq) (so, PRU_CONNECT,
220             (struct mbuf *) 0, nam, (struct mbuf *) 0);
221     splx(s);
222     return (error);
223 }

```

*uipc\_socket.c*

*uipc\_socket.c*

alls.c

Figure 15.33 `soconnect` function.

198-222 `soconnect` returns `EOPNOTSUPP` if the socket is marked to accept connections, since a process cannot initiate connections if `listen` has already been called for the socket. `EISCONN` is returned if the protocol is connection oriented and a connection has already been initiated. For a connectionless protocol, any existing association with a foreign address is broken by `sodisconnect`.

The `PRU_CONNECT` request starts the appropriate protocol processing to establish the connection or the association.

### Breaking a Connectionless Association

For connectionless protocols, the foreign address associated with a socket can be discarded by calling `connect` with an invalid name such as a pointer to a structure filled with 0s or a structure with an invalid size. `sodisconnect` removes a foreign address associated with the socket, and `PRU_CONNECT` returns an error such as `EAFNOSUPPORT` or `EADDRNOTAVAIL`, leaving the socket with no foreign address. This is a useful, although obscure, way of breaking the association between a connectionless socket and a foreign address without replacing it.

## 15.14 shutdown System Call

The `shutdown` system call, shown in Figure 15.34, closes the write-half, read-half, or both halves of a connection. For the read-half, `shutdown` discards any data the process hasn't yet read and any data that arrives after the call to `shutdown`. For the write-half, `shutdown` lets the protocol specify the semantics. For TCP, any remaining data will be sent followed by a FIN. This is TCP's half-close feature (Section 18.5 of Volume 1).

To destroy the socket and release the descriptor, `close` must be called. `close` can also be called directly without first calling `shutdown`. As with all descriptors, `close` is called by the kernel for sockets that have not been closed when a process terminates.

```

550 struct shutdown_args {
551     int     s;
552     int     how;
553 };
554 shutdown(p, uap, retval)
555 struct proc *p;
556 struct shutdown_args *uap;
557 int     *retval;
558 {
559     struct file *fp;
560     int     error;
561     if (error = getsock(p->p_fd, uap->s, &fp))
562         return (error);
563     return (sosshutdown((struct socket *) fp->f_data, uap->how));
564 }

```

*uipc\_syscalls.c*

*uipc\_syscalls.c*

Figure 15.34 `shutdown` system call.



550-557 In the `shutdown_args` structure, `s` is the socket descriptor and `how` specifies which halves of the connection are to be closed. Figure 15.35 shows the expected values for `how` and `how++` (which is used in Figure 15.36).

how	how++	Description
0	<code>FREAD</code>	shut down the read-half of the connection
1	<code>FWRITE</code>	shut down the write-half of the connection
2	<code>FREAD FWRITE</code>	shut down both halves of the connection

Figure 15.35 shutdown system call options.

Notice that there is an implicit numerical relationship between `how` and the constants `FREAD` and `FWRITE`.

558-564 `shutdown` is a wrapper function for `soshutdown`. The socket associated with the descriptor is returned by `getsock`, `soshutdown` is called, and its value is returned.

#### **soshutdown and sorflush Functions**

The shut down of the read-half of a connection is handled in the socket layer by `sorflush`, and the shut down of the write-half of a connection is processed by the `PRU_SHUTDOWN` request in the protocol layer. The `soshutdown` function is shown in Figure 15.36.

```

720 soshutdown(so, how)                                     uipc_socket.c
721 struct socket *so;
722 int    how;
723 {
724     struct protosw *pr = so->so_proto;
725     how++;
726     if (how & FREAD)
727         sorflush(so);
728     if (how & FWRITE)
729         return ((*pr->pr_usrreq) (so, PRU_SHUTDOWN,
730             (struct mbuf *) 0, (struct mbuf *) 0, (struct mbuf *) 0));
731     return (0);
732 }

```

uipc\_socket.c

Figure 15.36 soshutdown function.

720-732 If the read-half of the socket is being closed, `sorflush`, shown in Figure 15.37, discards the data in the socket's receive buffer and disables the read-half of the connection. If the write-half of the socket is being closed, the `PRU_SHUTDOWN` request is issued to the protocol.

733-747 The process waits for a lock on the receive buffer. Because of `SB_NOINTR`, `sblock` does not return when an interrupt occurs. `splimp` blocks network interrupts and protocol processing while the socket is modified, since the receive buffer may be accessed by the protocol layer as it processes incoming packets.

```

733 sorflush(so)
734 struct socket *so;
735 {
736     struct sockbuf *sb = &so->so_rcv;
737     struct protosw *pr = so->so_proto;
738     int s;
739     struct sockbuf asb;
740     sb->sb_flags |= SB_NOINTR;
741     (void) sblock(sb, M_WAITOK);
742     s = splimp();
743     socantrcvmore(so);
744     sbunlock(sb);
745     asb = *sb;
746     bzero((caddr_t) sb, sizeof(*sb));
747     splx(s);
748     if (pr->pr_flags & PR_RIGHTS && pr->pr_domain->dom_dispose)
749         (*pr->pr_domain->dom_dispose) (asb.sb_mb);
750     sbrelease(&asb);
751 }

```

Figure 15.37 sorflush function.

socantrcvmore marks the socket to reject incoming packets. A copy of the sockbuf structure is saved in asb to be used after interrupts are restored by splx. The original sockbuf structure is cleared by bzero, so that the receive queue appears to be empty.

#### Release control mbufs

748-751 Some kernel resources may be referenced by control information present in the receive queue when shutdown was called. The mbuf chain is still available through sb\_mb in the copy of the sockbuf structure.

If the protocol supports access rights and has registered a dom\_dispose function, it is called here to release these resources.

In the Unix domain it is possible to pass descriptors between processes with control messages. These messages contain pointers to reference counted data structures. The dom\_dispose function takes care of discarding the references and the data structures if necessary to avoid creating an unreferenced structure and introducing a memory leak in the kernel. For more information on passing file descriptors within the Unix domain, see [Stevens 1990] and [Leffler et al. 1989].

Any input data pending when shutdown is called is discarded when sbrelease releases any mbufs on the receive queue.

Notice that the shut down of the read-half of the connection is processed entirely by the socket layer (Exercise 15.6) and the shut down of the write-half of the connection is handled by the protocol through the PRU\_SHUTDOWN request. TCP responds to the PRU\_SHUTDOWN by sending all queued data and then a FIN to close the write-half of the TCP connection.

## 15.15 close System Call

The `close` system call works with any type of descriptor. When `fd` is the last descriptor that references the object, the object-specific `close` function is called:

```
error = (*fp->f_ops->fo_close)(fp, p);
```

As shown in Figure 15.13, `fp->f_ops->fo_close` for a socket is the function `soo_close`.

### soo\_close Function

This function, shown in Figure 15.38, is a wrapper for the `soclose` function.

```

152 soo_close(fp, p)
153 struct file *fp;
154 struct proc *p;
155 {
156     int     error = 0;
157     if (fp->f_data)
158         error = soclose((struct socket *) fp->f_data);
159     fp->f_data = 0;
160     return (error);
161 }

```

*sys\_socket.c*

*sys\_socket.c*

Figure 15.38 `soo_close` function.

152-161 If a socket structure is associated with the file structure, `soclose` is called, `f_data` is cleared, and any posted error is returned.

### soclose Function

This function aborts any connections that are pending on the socket (i.e., that have not yet been accepted by a process), waits for data to be transmitted to the foreign system, and releases the data structures that are no longer needed.

`soclose` is shown in Figure 15.39.

#### Discard pending connections

129-141 If the socket was accepting connections, `soclose` traverses the two connection queues and calls `soabort` for each pending connection. If the protocol control block is null, the protocol has already been detached from the socket and `soclose` jumps to the cleanup code at `discard`.

`soabort` issues the `PRU_ABORT` request to the socket's protocol and returns the result. `soabort` is not shown in this text. Figures 23.38 and 30.7 discuss how UDP and TCP handle this request.

```

129 soclose(so)
130 struct socket *so;
131 {
132     int     s = splnet();      /* conservative */
133     int     error = 0;

134     if (so->so_options & SO_ACCEPTCONN) {
135         while (so->so_q0)
136             (void) soabort(so->so_q0);
137         while (so->so_q)
138             (void) soabort(so->so_q);
139     }
140     if (so->so_pcb == 0)
141         goto discard;
142     if (so->so_state & SS_ISCONNECTED) {
143         if ((so->so_state & SS_ISDISCONNECTING) == 0) {
144             error = sodisconnect(so);
145             if (error)
146                 goto drop;
147         }
148         if (so->so_options & SO_LINGER) {
149             if ((so->so_state & SS_ISDISCONNECTING) &&
150                 (so->so_state & SS_NBIO))
151                 goto drop;
152             while (so->so_state & SS_ISCONNECTED)
153                 if (error = tsleep((caddr_t) & so->so_timeo,
154                                     PSOCK | PCATCH, netcls, so->so_linger))
155                     break;
156         }
157     }
158     drop:
159     if (so->so_pcb) {
160         int     error2 =
161             (*so->so_proto->pr_usrreq) (so, PRU_DETACH,
162             (struct mbuf *) 0, (struct mbuf *) 0, (struct mbuf *) 0);
163         if (error == 0)
164             error = error2;
165     }
166     discard:
167     if (so->so_state & SS_NOFDREF)
168         panic("soclose: NOFDREF");
169     so->so_state |= SS_NOFDREF;
170     sofree(so);
171     splx(s);
172     return (error);
173 }

```

Figure 15.39 soclose function.

**Break established connection or association**

142-157 If the socket is not connected, execution continues at `drop`; otherwise the socket must be disconnected from its peer. If a disconnect is not in progress, `sodisconnect` starts the disconnection process. If the `SO_LINGER` socket option is set, `sockclose` may need to wait for the disconnect to complete before returning. A nonblocking socket never waits for a disconnect to complete, so `sockclose` jumps immediately to `drop` in that case. Otherwise, the connection termination is in progress and the `SO_LINGER` option indicates that `sockclose` must wait some time for it to complete. The while loop continues until the disconnect completes, the linger time (`so_linger`) expires, or a signal is delivered to the process.

If the linger time is set to 0, `tsleep` returns only when the disconnect completes (perhaps because of an error) or a signal is delivered.

**Release data structures**

158-173 If the socket still has an attached protocol, the `PRU_DETACH` request breaks the connection between this socket and the protocol. Finally the socket is marked as not having an associated file descriptor, which allows `sofree` to release the socket.

The `sofree` function is shown in Figure 15.40.

```

110 sofree(so)
111 struct socket *so;
112 {
113     if (so->so_pcb || (so->so_state & SS_NOFDREF) == 0)
114         return;
115     if (so->so_head) {
116         if (!soqremque(so, 0) && !soqremque(so, 1))
117             panic("sofree dq");
118         so->so_head = 0;
119     }
120     sbrelease(&so->so_snd);
121     sorflush(so);
122     FREE(so, M_SOCKET);
123 }

```

*uipc\_socket.c*

*uipc\_socket.c*

Figure 15.40 `sofree` function.

**Return if socket still in use**

110-114 If a protocol is still associated with the socket, or if the socket is still associated with a descriptor, `sofree` returns immediately.

**Remove from connection queues**

115-119 If the socket is on a connection queue (`so_head` is nonnull), `soqremque` is called to remove the socket. An attempt is made to remove the socket from the incomplete connection queue and if this fails, then from the completed connection queue. One of the removals must succeed or the kernel panics, since `so_head` was nonnull. `so_head` is cleared.

**Discard send and receive queues**

120-123 `sbrelease` discards any buffers in the send queue and `sorflush` discards any buffers in the receive queue. Finally, the socket itself is released.

**15.16 Summary**

In this chapter we looked at all the system calls related to network operations. The system call mechanism was described, and we traced the calls until they entered the protocol processing layer through the `pr_usrreq` function.

While looking at the socket layer, we avoided any discussion of address formats, protocol semantics, or protocol implementations. In the upcoming chapters we tie together the link-layer processing and socket-layer processing by looking in detail at the implementation of the Internet protocols in the protocol processing layer.

**Exercises**

- 15.1 How can a process *without* superuser privileges gain access to a socket created by a super-user process?
- 15.2 How can a process determine if the `sockaddr` buffer it provides to `accept` was too small to hold the foreign address returned by the call?
- 15.3 A feature proposed for IPv6 sockets is to have `accept` and `recvfrom` return a source route as an array of 128-bit IPv6 addresses instead of a single peer address. Since the array will not fit in a single mbuf, modify `accept` and `recvfrom` to handle an mbuf chain from the protocol layer instead of a single mbuf. Will the existing code work if the protocol layer returns the array in an mbuf cluster instead of a chain of mbufs?
- 15.4 Why is `panic` called when `soremque` returns a null pointer in Figure 15.26?
- 15.5 Why does `sorflush` make a copy of the receive buffer?
- 15.6 What happens when additional data is received after `sorflush` has zeroed the socket's receive buffer? Read Chapter 16 before attempting this exercise.

# 16

## Socket I/O

### 16.1 Introduction

In this chapter we discuss the system calls that read and write data on a network connection. The chapter is divided into three parts.

The first part covers the four system calls for sending data: `write`, `writv`, `sendto`, and `sendmsg`. The second part covers the four system calls for receiving data: `read`, `readv`, `recvfrom`, and `recvmsg`. The third part of the chapter covers the `select` system call, which provides a standard way to monitor the status of descriptors in general and sockets in particular.

The core of the socket layer is the `send` and `receive` functions. They handle all I/O between the socket layer and the protocol layer. As we'll see, the semantics of the various types of protocols overlap in these functions, making the functions long and complex.

### 16.2 Code Introduction

The three headers and four C files listed in Figure 16.1 are covered in this chapter.

#### Global Variables

The first two global variables shown in Figure 16.2 are used by the `select` system call. The third global variable controls the amount of memory allocated to a socket.

File	Description
sys/socket.h	structures and macro for sockets API
sys/socketvar.h	socket structure and macros
sys/uio.h	uio structure definition
kern/uipc_syscalls.c	socket system calls
kern/uipc_socket.c	socket layer processing
kern/sys_generic.c	select system call
kern/sys_socket.c	select processing for sockets

Figure 16.1 Files discussed in this chapter.

Variable	Datatype	Description
selwait	int	wait channel for select
nselect	int	flag used to avoid race conditions in select
sb_max	u_long	maximum number of bytes to allocate for a socket receive or send buffer

Figure 16.2 Global variables introduced in this chapter.

### 16.3 Socket Buffers

Section 15.3 showed that each socket has an associated send and receive buffer. The sockbuf structure definition from Figure 15.5 is repeated in Figure 16.3.

```

72  struct sockbuf {
73      u_long  sb_cc;          /* actual chars in buffer */
74      u_long  sb_hiwat;      /* max actual char count */
75      u_long  sb_mbcnt;      /* chars of mbufs used */
76      u_long  sb_mbmax;      /* max chars of mbufs to use */
77      long    sb_lowat;      /* low water mark */
78      struct mbuf *sb_mb;    /* the mbuf chain */
79      struct selinfo sb_sel; /* process selecting read/write */
80      short   sb_flags;      /* Figure 16.5 */
81      short   sb_timeo;      /* timeout for read/write */
82  } so_rcv, so_snd;

```

socketvar.h

Figure 16.3 sockbuf structure.

Each buffer contains control information as well as pointers to data stored in mbuf chains. `sb_mb` points to the first mbuf in the chain, and `sb_cc` is the total number of data bytes contained within the mbufs. `sb_hiwat` and `sb_lowat` regulate the socket flow control algorithms. `sb_mbcnt` is the total amount of memory allocated to the mbufs in the buffer.

Recall that each mbuf may store from 0 to 2048 bytes of data (if an external cluster is used). `sb_mbmax` is an upper bound on the amount of memory to be allocated as

S



mbufs for each socket buffer. Default limits are specified by each protocol when the `PRU_ATTACH` request is issued by the `socket` system call. The high-water and low-water marks may be modified by the process as long as the kernel-enforced hard limit of 262,144 bytes per socket buffer (`sb_max`) is not exceeded. The buffering algorithms are described in Sections 16.7 and 16.12. Figure 16.4 shows the default settings for the Internet protocols.

Protocol	so_snd			so_rcv		
	sb_hiwat	sb_lowat	sb_mbmax	sb_hiwat	sb_lowat	sb_mbmax
UDP	9 × 1024	2048 (ignored)	2 × sb_hiwat	40 × (1024 + 16)	1	2 × sb_hiwat
TCP	8 × 1024	2048	2 × sb_hiwat	8 × 1024	1	2 × sb_hiwat
raw IP	8 × 1024	2048 (ignored)	2 × sb_hiwat	8 × 1024	1	2 × sb_hiwat
ICMP						
IGMP						

Figure 16.4 Default socket buffer limits for the Internet protocols.

Since the source address of each incoming UDP datagram is queued with the data (Section 23.8), the default UDP value for `sb_hiwat` is set to accommodate 40 1K datagrams and their associated `sockaddr_in` structures (16 bytes each).

79 `sb_sel` is a `selinfo` structure used to implement the `select` system call (Section 16.13).

80 Figure 16.5 lists the possible values for `sb_flags`.

sb_flags	Description
<code>SB_LOCK</code>	a process has locked the socket buffer
<code>SB_WANT</code>	a process is waiting to lock the buffer
<code>SB_WAIT</code>	a process is waiting for data (receive) or space (send) in this buffer
<code>SB_SEL</code>	one or more processes are selecting on this buffer
<code>SB_ASYNC</code>	generate asynchronous I/O signal for this buffer
<code>SB_NOINTR</code>	signals do not cancel a lock request
<code>SB_NOTIFY</code>	( <code>SB_WAIT</code>   <code>SB_SEL</code>   <code>SB_ASYNC</code> ) a process is waiting for changes to the buffer and should be notified by wakeup when any changes occur

Figure 16.5 `sb_flags` values.

81-82 `sb_timeo` is measured in clock ticks and limits the time a process blocks during a read or write call. The default value of 0 causes the process to wait indefinitely. `sb_timeo` may be changed or retrieved by the `SO_SNDTIMEO` and `SO_RCVTIMEO` socket options.

### Socket Macros and Functions

There are many macros and functions that manipulate the send and receive buffers associated with each socket. The macros and functions in Figure 16.6 handle buffer locking and synchronization.

Name	Description
sblock	Acquires a lock for <i>sb</i> . If <i>wf</i> is <code>M_WAITOK</code> , the process sleeps waiting for the lock; otherwise <code>EWOULDBLOCK</code> is returned if the buffer cannot be locked immediately. <code>EINTR</code> or <code>ERESTART</code> is returned if the sleep is interrupted by a signal; 0 is returned otherwise.  <code>int sblock(struct sockbuf *sb, int wf);</code>
sbunlock	Releases the lock on <i>sb</i> . Any other process waiting to lock <i>sb</i> is awakened.  <code>void sbunlock(struct sockbuf *sb);</code>
sbwait	Calls <code>tsleep</code> to wait for protocol activity on <i>sb</i> . Returns result of <code>tsleep</code> .  <code>int sbwait(struct sockbuf *sb);</code>
sowakeup	Notifies socket of protocol activity. Wakes up matching call to <code>sbwait</code> or to <code>tsleep</code> if any processes are selecting on <i>sb</i> .  <code>void sowakeup(struct socket *so, struct sockbuf *sb);</code>
sorwakeup	Wakes up any process waiting for read events on <i>so</i> and sends the <code>SIGIO</code> signal if a process requested asynchronous notification of I/O.  <code>void sorwakeup(struct socket *so);</code>
sowwakeup	Wakes up any process waiting for write events on <i>so</i> and sends the <code>SIGIO</code> signal if a process requested asynchronous notification of I/O.  <code>void sowwakeup(struct socket *so);</code>

Figure 16.6 Macros and functions for socket buffer locking and synchronization.

Figure 16.7 includes the macros and functions used to set the resource limits for socket buffers and to append and delete data from the buffers. In the table, *m*, *m0*, *n*, and *control* are all pointers to mbuf chains. *sb* points to the send or receive buffer for a socket.

Name	Description
sbospace	The number of bytes that may be added to <i>sb</i> before it is considered full: <code>min((sb_hiwat - sb_cc), (sb_mbmax - sb_mbcnt))</code> .  <code>long sbospace(struct sockbuf *sb);</code>
sballloc	<i>m</i> has been added to <i>sb</i> . Adjust <code>sb_cc</code> and <code>sb_mbcnt</code> in <i>sb</i> accordingly.  <code>void sballloc(struct sockbuf *sb, struct mbuf *m);</code>
sbfree	<i>m</i> has been removed from <i>sb</i> . Adjust <code>sb_cc</code> and <code>sb_mbcnt</code> in <i>sb</i> accordingly.  <code>int sbfree(struct sockbuf *sb, struct mbuf *m);</code>

Name	Description
sbappend	Append the mbufs in <i>m</i> to the end of the last record in <i>sb</i> . Call <code>sbcompress</code> . <pre>int sbappend(struct sockbuf *sb, struct mbuf *m);</pre>
sbappendrecord	Append the record in <i>m0</i> after the last record in <i>sb</i> . Call <code>sbcompress</code> . <pre>int sbappendrecord(struct sockbuf *sb, struct mbuf *m0);</pre>
sbappendaddr	Put address from <i>asa</i> in an mbuf. Concatenate address, <i>control</i> , and <i>m0</i> . Append the resulting mbuf chain after the last record in <i>sb</i> . <pre>int sbappendaddr(struct sockbuf *sb, struct sockaddr *asa,                  struct mbuf *m0, struct mbuf *control);</pre>
sbappendcontrol	Concatenate <i>control</i> and <i>m0</i> . Append the resulting mbuf chain after the last record in <i>sb</i> . <pre>int sbappendcontrol(struct sockbuf *sb, struct mbuf *m0,                    struct mbuf *control);</pre>
sbinsertoob	Insert <i>m0</i> before first record in <i>sb</i> without out-of-band data. Call <code>sbcompress</code> . <pre>int sbinsertoob(struct sockbuf *sb, struct mbuf *m0);</pre>
sbcompress	Append <i>m</i> to <i>n</i> squeezing out any unused space. <pre>void sbcompress(struct sockbuf *sb, struct mbuf *m,                struct mbuf *n);</pre>
sbdrop	Discard <i>len</i> bytes from the front of <i>sb</i> . <pre>void sbdrop(struct sockbuf *sb, int len);</pre>
sbdroprecord	Discard the first record in <i>sb</i> . Move the next record to the front. <pre>void sbdroprecord(struct sockbuf *sb);</pre>
sbrelease	Call <code>sbflush</code> to release all mbufs in <i>sb</i> . Reset <code>sb_hiwat</code> and <code>sb_mbmax</code> values to 0. <pre>void sbrelease(struct sockbuf *sb);</pre>
sbflush	Release all mbufs in <i>sb</i> . <pre>void sbflush(struct sockbuf *sb);</pre>
soreserve	Set high-water and low-water marks. For the send buffer, call <code>sbreserve</code> with <i>sndcc</i> . For the receive buffer, call <code>sbreserve</code> with <i>rcvcc</i> . Initialize <code>sb_lowat</code> in both buffers to default values, Figure 16.4. <code>ENOBUFS</code> is returned if any limits are exceeded. <pre>int soreserve(struct socket *so, int sndcc, int rcvcc);</pre>
sbreserve	Set high-water mark for <i>sb</i> to <i>cc</i> . Also drop low-water mark to <i>cc</i> . No memory is allocated by this function. <pre>int sbreserve(struct sockbuf *sb, int cc);</pre>

Figure 16.7 Macros and functions for socket buffer allocation and manipulation.

### 16.4 write, writev, sendto, and sendmsg System Calls

These four system calls, which we refer to collectively as the *write system calls*, send data on a network connection. The first three system calls are simpler interfaces to the most general request, `sendmsg`.

All the write system calls, directly or indirectly, call `sosend`, which does the work of copying data from the process to the kernel and passing data to the protocol associated with the socket. Figure 16.8 summarizes the flow of control.

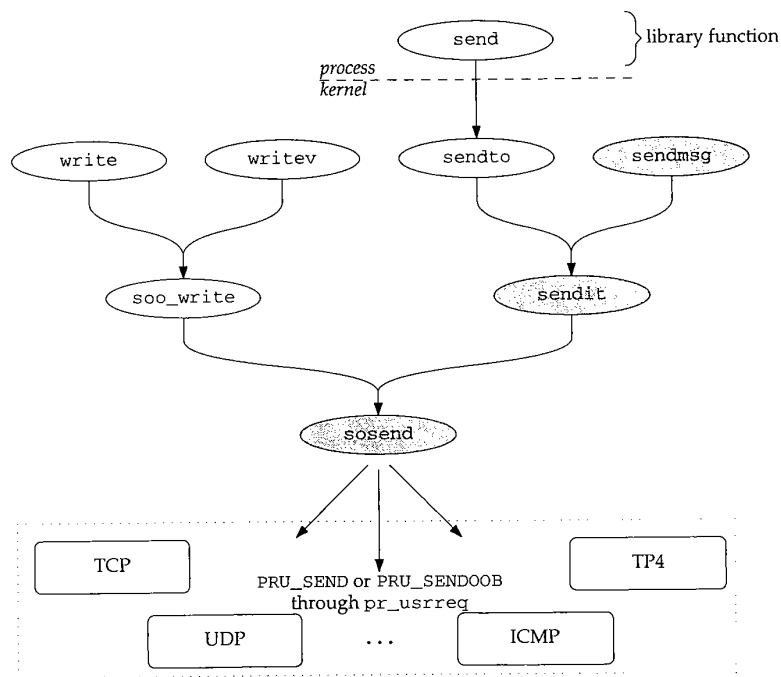

Figure 16.8 All socket output is handled by `sosend`.

In the following sections, we discuss the functions shaded in Figure 16.8. The other four system calls and `soo_write` are left for readers to investigate on their own.

Figure 16.9 shows the features of these four system calls and a related library function (`send`).

In Net/3, `send` is implemented as a library function that calls `sendto`. For binary compatibility with previously compiled programs, the kernel maps the old `send` system call to the function `osend`, which is not discussed in this text.

From the second column in Figure 16.9 we see that the `write` and `writev` system calls are valid with any descriptor, but the remaining system calls are valid only with socket descriptors.

ta  
st  
k  
i-

Function	Type of descriptor	Number of buffers	Specify destination address?	Flags?	Control information?
write	any	1			
writev	any	[1..UIO_MAXIOV]			
send	socket only	1		•	
sendto	socket only	1	•	•	
sendmsg	socket only	[1..UIO_MAXIOV]	•	•	•

Figure 16.9 Write system calls.

The third column shows that `writev` and `sendmsg` accept data from multiple buffers. Writing from multiple buffers is called *gathering*. The analogous read operation is called *scattering*. In a gather operation the kernel accepts, in order, data from each buffer specified in an array of `iovec` structures. The array can have a maximum of `UIO_MAXIOV` elements. The structure is shown in Figure 16.10.

```

41 struct iovec {
42     char *iov_base;           /* Base address */
43     size_t iov_len;          /* Length */
44 };

```

uio.h

Figure 16.10 iovec structure.

41-44 `iov_base` points to the start of a buffer of `iov_len` bytes.

Without this type of interface, a process would have to copy buffers into a single larger buffer or make multiple write system calls to send data from multiple buffers. Both alternatives are less efficient than passing an array of `iovec` structures to the kernel in a single call. With datagram protocols, the result of one `writev` is one datagram, which cannot be emulated with multiple writes.

Figure 16.11 illustrates the structures as they are used by `writev`, where `iovp` points to the first element of the array and `iovcnt` is the size of the array.

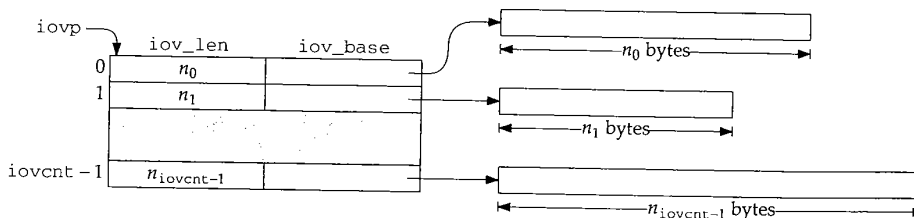

Figure 16.11 iovec arguments to writev.

Datagram protocols require a destination address to be associated with each write call. Since `write`, `writev`, and `send` do not accept an explicit destination, they may be called only after a destination has been associated with a connectionless socket by calling `connect`. A destination must be provided with `sendto` or `sendmsg`, or `connect` must have been previously called.

The fifth column in Figure 16.9 shows that the `sendxxx` system calls accept optional control flags, which are described in Figure 16.12.

flags	Description	Reference
<code>MSG_DONTROUTE</code>	bypass routing tables for this message	Figure 16.23
<code>MSG_DONTWAIT</code>	do not wait for resources during this message	Figure 16.22
<code>MSG_EOR</code>	data marks the end of a logical record	Figure 16.25
<code>MSG_OOB</code>	send as out-of-band data	Figure 16.26

Figure 16.12 `sendxxx` system calls: flags values.

As indicated in the last column of Figure 16.9, only the `sendmsg` system call supports control information. The control information and several other arguments to `sendmsg` are specified within a `msg_hdr` structure (Figure 16.13) instead of being passed separately.

```

228 struct msg_hdr {
229     caddr_t msg_name;          /* optional address */
230     u_int  msg_namelen;       /* size of address */
231     struct iovec *msg_iov;    /* scatter/gather array */
232     u_int  msg_iovlen;       /* # elements in msg_iov */
233     caddr_t msg_control;     /* ancillary data, see below */
234     u_int  msg_controllen;   /* ancillary data buffer len */
235     int    msg_flags;        /* Figure 16.33 */
236 };

```

*socket.h*

Figure 16.13 `msg_hdr` structure.

`msg_name` should be declared as a pointer to a `sockaddr` structure, since it contains a network address.

228-236 The `msg_hdr` structure contains a destination address (`msg_name` and `msg_namelen`), a scatter/gather array (`msg_iov` and `msg_iovlen`), control information (`msg_control` and `msg_controllen`), and receive flags (`msg_flags`). The control information is formatted as a `cmsghdr` structure shown in Figure 16.14.

```

251 struct cmsghdr {
252     u_int  cmsg_len;          /* data byte count, including hdr */
253     int    cmsg_level;       /* originating protocol */
254     int    cmsg_type;        /* protocol-specific type */
255     /* followed by u_char cmsg_data[]; */
256 };

```

*socket.h*

Figure 16.14 `cmsghdr` structure.

251-256 The control information is not interpreted by the socket layer, but the messages are typed (`cmsg_type`) and they have an explicit length (`cmsg_len`). Multiple control messages may appear in the control information mbuf.

**Example**

Figure 16.15 shows how a fully specified `msghdr` structure might look during a call to `sendmsg`.

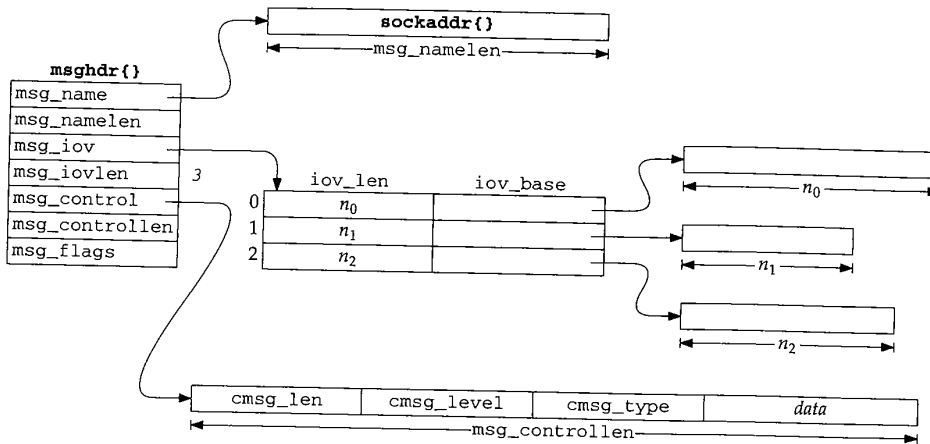

Figure 16.15 `msghdr` structure for `sendmsg` system call.

## 16.5 `sendmsg` System Call

Only the `sendmsg` system call provides access to all the features of the sockets API associated with output. The `sendmsg` and `sendit` functions prepare the data structures needed by `sosend`, which passes the message to the appropriate protocol. For `SOCK_DGRAM` protocols, a message is a datagram. For `SOCK_STREAM` protocols, a message is a sequence of bytes. For `SOCK_SEQPACKET` protocols, a message could be an entire record (implicit record boundaries) or part of a larger record (explicit record boundaries). A message is always an entire record (implicit record boundaries) for `SOCK_RDM` protocols.

Even though the general `sosend` code handles `SOCK_SEQPACKET` and `SOCK_RDM` protocols, there are no such protocols in the Internet domain.

Figure 16.16 shows the `sendmsg` code.

307-321 There are three arguments to `sendmsg`: the socket descriptor; a pointer to a `msghdr` structure; and several control flags. The `copyin` function copies the `msghdr` structure from user space to the kernel.

### Copy `iovec` array

322-334 An `iovec` array with eight entries (`UIO_SMALLIOV`) is allocated automatically on the stack. If this is not large enough, `sendmsg` calls `MALLOC` to allocate a larger array. If

```

307 struct sendmsg_args {
308     int     s;
309     caddr_t msg;
310     int     flags;
311 };

312 sendmsg(p, uap, retval)
313 struct proc *p;
314 struct sendmsg_args *uap;
315 int     *retval;
316 {
317     struct msghdr msg;
318     struct iovec aiov[UIO_SMALLIOV], *iov;
319     int     error;

320     if (error = copyin(uap->msg, (caddr_t) &msg, sizeof(msg)))
321         return (error);
322     if ((u_int) msg.msg_iovlen >= UIO_SMALLIOV) {
323         if ((u_int) msg.msg_iovlen >= UIO_MAXIOV)
324             return (EMSGSIZE);
325         MALLOC(iov, struct iovec *,
326             sizeof(struct iovec) * (u_int) msg.msg_iovlen, M_IOV,
327             M_WAITOK);
328     } else
329         iov = aiov;
330     if (msg.msg_iovlen &&
331         (error = copyin((caddr_t) msg.msg_iov, (caddr_t) iov,
332             (unsigned) (msg.msg_iovlen * sizeof(struct iovec)))))
333         goto done;
334     msg.msg_iov = iov;
335     error = sendit(p, uap->s, &msg, uap->flags, retval);
336 done:
337     if (iov != aiov)
338         FREE(iov, M_IOV);
339     return (error);
340 }

```

Figure 16.16 sendmsg system call.

the process specifies an array with more than 1024 (`UIO_MAXIOV`) entries, `EMSGSIZE` is returned. `copyin` places a copy of the `iovec` array from user space into either the array on the stack or the larger, dynamically allocated, array.

This technique avoids the relatively expensive call to `malloc` in the most common case of eight or fewer entries.

#### sendit and cleanup

335-340 When `sendit` returns, the data has been delivered to the appropriate protocol or an error has occurred. `sendmsg` releases the `iovec` array (if it was dynamically allocated) and returns `sendit`'s result.



## 16.6 sendit Function

`sendit` is the common function called by `sendto` and `sendmsg`. `sendit` initializes a `uio` structure and copies control and address information from the process into the kernel. Before discussing `send`, we must explain the `uiomove` function and the `uio` structure.

### uiomove Function

The prototype for this function is:

```
int uiomove(caddr_t cp, int n, struct uio *uio);
```

The `uiomove` function moves `n` bytes between a single buffer referenced by `cp` and the multiple buffers specified by an `iovec` array in `uio`. Figure 16.17 shows the definition of the `uio` structure, which controls and records the actions of the `uiomove` function.

```

45 enum uio_rw {                               uio.h
46     UIO_READ, UIO_WRITE
47 };

48 enum uio_seg {                               /* Segment flag values */
49     UIO_USERSPACE, /* from user data space */
50     UIO_SYSSPACE, /* from system space */
51     UIO_USERISPACE /* from user instruction space */
52 };

53 struct uio {
54     struct iovec *uio_iov; /* an array of iovec structures */
55     int uio_iovcnt; /* size of iovec array */
56     off_t uio_offset; /* starting position of transfer */
57     int uio_resid; /* remaining bytes to transfer */
58     enum uio_seg uio_segflg; /* location of buffers */
59     enum uio_rw uio_rw; /* direction of transfer */
60     struct proc *uio_procp; /* the associated process */
61 };

```

Figure 16.17 `uio` structure.

<sup>45-61</sup> In the `uio` structure, `uio_iov` points to an array of `iovec` structures, `uio_offset` counts the number of bytes transferred by `uiomove`, and `uio_resid` counts the number of bytes remaining to be transferred. Each time `uiomove` is called, `uio_offset` increases by `n` and `uio_resid` decreases by `n`. `uiomove` adjusts the base pointers and buffer lengths in the `uio_iov` array to exclude any bytes that `uiomove` transfers each time it is called. Finally, `uio_iov` is advanced through each entry in the array as each buffer is transferred. `uio_segflg` indicates the location of the buffers specified by the base pointers in the `uio_iov` array and `uio_rw` indicates the direction of the transfer. The buffers may be located in the user data space, user instruction space, or kernel data space. Figure 16.18 summarizes the operation of `uiomove`. The descriptions use the argument names shown in the `uiomove` prototype.

uio_segflg	uio_rw	Description
UIO_USERSPACE	UIO_READ	scatter $n$ bytes from a kernel buffer $cp$ to process buffers
UIO_USERSPACE		
UIO_USERSPACE	UIO_WRITE	gather $n$ bytes from process buffers into the kernel buffer $cp$
UIO_USERSPACE		
UIO_SYSSPACE	UIO_READ	scatter $n$ bytes from the kernel buffer $cp$ to multiple kernel buffers
	UIO_WRITE	gather $n$ bytes from multiple kernel buffers into the kernel buffer $cp$

Figure 16.18 uiomove operation.

**Example**

Figure 16.19 shows a uio structure before uiomove is called.

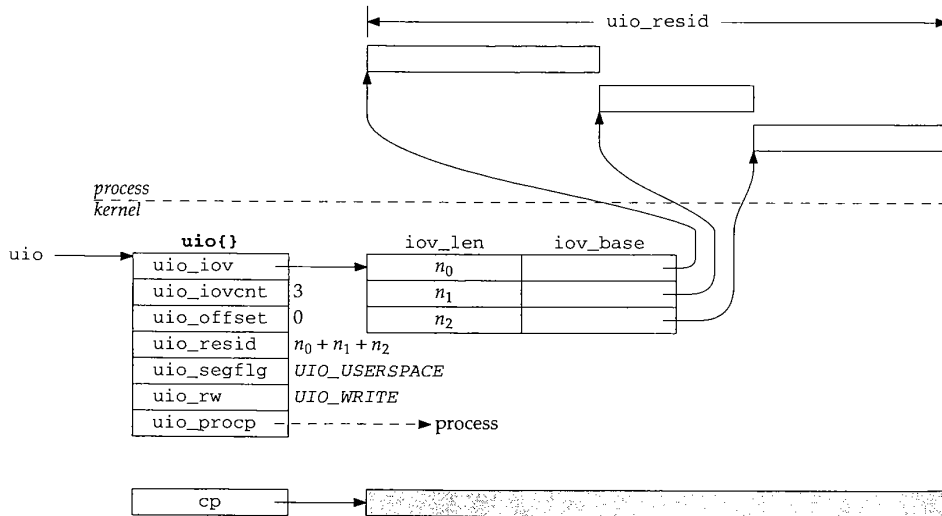

Figure 16.19 uiomove: before.

`uio_iov` points to the first entry in the `iovec` array. Each of the `iovec_base` pointers point to the start of their respective buffer in the address space of the process. `uio_offset` is 0, and `uio_resid` is the sum of size of the three buffers. `cp` points to a buffer within the kernel, typically the data area of an mbuf. Figure 16.20 shows the same data structures after

```
uiomove(cp, n, uio);
```

is executed where  $n$  includes all the bytes from the first buffer and only some of the bytes from the second buffer (i.e.,  $n_0 < n < n_0 + n_1$ ).

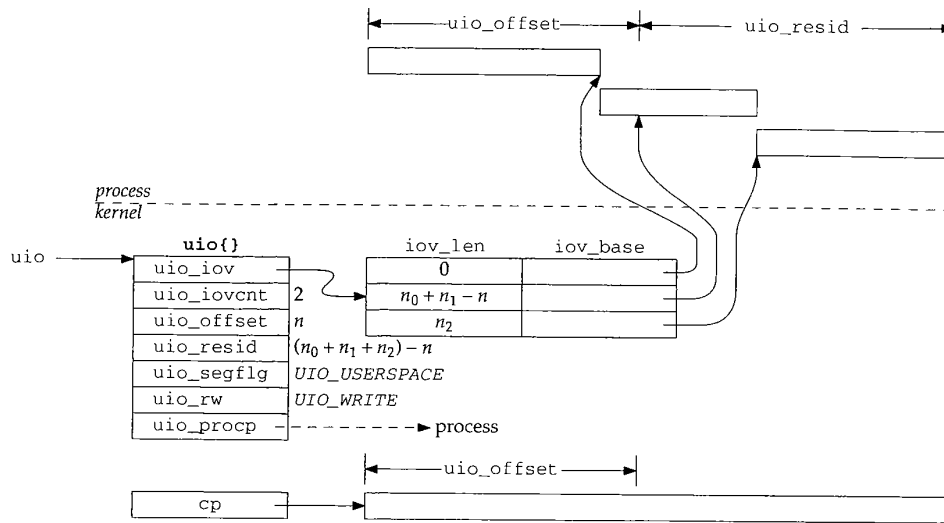

Figure 16.20 uiomove: after.

After `uiomove`, the first buffer has a length of 0 and its base pointer has been advanced to the end of the buffer. `uio_iov` now points to the second entry in the `iovec` array. The pointer in this entry has been advanced and the length decreased to reflect the transfer of some of the bytes in the buffer. `uio_offset` has been increased by  $n$  and `uio_resid` has been decreased by  $n$ . The data from the buffers in the process has been moved into the kernel's buffer because `uio_rw` was `UIO_WRITE`.

### sendit Code

We can now discuss the `sendit` code shown in Figure 16.21.

#### Initialize `uio`

341-368 `sendit` calls `getsock` to get the file structure associated with the descriptor `s` and initializes the `uio` structure to gather the output buffers specified by the process into mbufs in the kernel. The length of the transfer is calculated by the `for` loop as the sum of the buffer lengths and saved in `uio_resid`. The first `if` within the loop ensures that the buffer length is nonnegative. The second `if` ensures that `uio_resid` does not overflow, since `uio_resid` is a signed integer and `iov_len` is guaranteed to be nonnegative.

#### Copy address and control information from the process

369-385 `sockargs` makes copies of the destination address and control information into mbufs if they are provided by the process.

uipc\_syscalls.c

```

341 sendit(p, s, mp, flags, retsize)
342 struct proc *p;
343 int s;
344 struct msghdr *mp;
345 int flags, *retsize;
346 {
347     struct file *fp;
348     struct uio auio;
349     struct iovec *iov;
350     int i;
351     struct mbuf *to, *control;
352     int len, error;
353     if (error = getsock(p->p_fd, s, &fp))
354         return (error);
355     auio.uio_iov = mp->msg_iov;
356     auio.uio_iovcnt = mp->msg_iovlen;
357     auio.uio_segflg = UIO_USERSPACE;
358     auio.uio_rw = UIO_WRITE;
359     auio.uio_procp = p;
360     auio.uio_offset = 0; /* XXX */
361     auio.uio_resid = 0;
362     iov = mp->msg_iov;
363     for (i = 0; i < mp->msg_iovlen; i++, iov++) {
364         if (iov->iov_len < 0)
365             return (EINVAL);
366         if ((auio.uio_resid += iov->iov_len) < 0)
367             return (EINVAL);
368     }
369     if (mp->msg_name) {
370         if (error = sockargs(&to, mp->msg_name, mp->msg_namelen,
371             MT_SONAME))
372             return (error);
373     } else
374         to = 0;
375     if (mp->msg_control) {
376         if (mp->msg_controllen < sizeof(struct cmsghdr)
377             ) {
378             error = EINVAL;
379             goto bad;
380         }
381         if (error = sockargs(&control, mp->msg_control,
382             mp->msg_controllen, MT_CONTROL))
383             goto bad;
384     } else
385         control = 0;
386     len = auio.uio_resid;
387     if (error = sosend((struct socket *) fp->f_data, to, &auio,
388         (struct mbuf *) 0, control, flags)) {
389         if (auio.uio_resid != len && (error == ERESTART ||
390             error == EINTR || error == EWOULDBLOCK))
391             error = 0;
392         if (error == EPIPE)
393             psignal(p, SIGPIPE);

```

```

394     }
395     if (error == 0)
396         *retsize = len - auio.uio_resid;
397     bad:
398     if (to)
399         m_freem(to);
400     return (error);
401 }

```

— *uipc\_syscalls.c*

Figure 16.21 sendit function.

### Send data and cleanup

386-401 `uio_resid` is saved in `len` so that the number of bytes transferred can be calculated if `sosend` does not accept all the data. The socket, destination address, `uio` structure, control information, and flags are all passed to `sosend`. When `sosend` returns, `sendit` responds as follows:

- If `sosend` transfers some data and is interrupted by a signal or a blocking condition, the error is discarded and the partial transfer is reported.
- If `sosend` returns `EPIPE`, the `SIGPIPE` signal is sent to the process. `error` is not set to 0, so if a process catches the signal and the signal handler returns, or if the process ignores the signal, the write call returns `EPIPE`.
- If no error occurred (or it was discarded), the number of bytes transferred is calculated and saved in `*retsize`. Since `sendit` returns 0, `syscall` (Section 15.4) returns `*retsize` to the process instead of returning the error code.
- If any other error occurs, the error code is returned to the process.

Before returning, `sendit` releases the mbuf containing the destination address. `sosend` is responsible for releasing the control mbuf.

## 16.7 sosend Function

`sosend` is one of the most complicated functions in the socket layer. Recall from Figure 16.8 that all five write calls eventually call `sosend`. It is `sosend`'s responsibility to pass the data and control information to the `pr_usrreq` function of the protocol associated with the socket according to the semantics supported by the protocol and the buffer limits specified by the socket. `sosend` never places data in the send buffer; it is the protocol's responsibility to store and remove the data.

The interpretation of the send buffer's `sb_hiwat` and `sb_lowat` values by `sosend` depends on whether the associated protocol implements reliable or unreliable data transfer semantics.

### Reliable Protocol Buffering

For reliable protocols, the send buffer holds both data that has not yet been transmitted and data that has been sent, but has not been acknowledged. `sb_cc` is the number of bytes of data that reside in the send buffer, and  $0 \leq sb\_cc \leq sb\_hiwat$ .

`sb_cc` may temporarily exceed `sb_hiwat` when out-of-band data is sent.

It is `send`'s responsibility to ensure that there is enough space in the send buffer before passing any data to the protocol layer through the `pr_usrreq` function. The protocol layer adds the data to the send buffer. `send` transfers data to the protocol in one of two ways:

- If `PR_ATOMIC` is set, `send` must preserve the message boundaries between the process and the protocol layer. In this case, `send` waits for enough space to become available to hold the entire message. When the space is available, an mbuf chain containing the entire message is constructed and passed to the protocol in a single call through the `pr_usrreq` function. RDP and SPP are examples of this type of protocol.
- If `PR_ATOMIC` is not set, `send` passes the message to the protocol one mbuf at a time and may pass a partial mbuf to avoid exceeding the high-water mark. This method is used with `SOCK_STREAM` protocols such as TCP and `SOCK_SEQPACKET` protocols such as TP4. With TP4, record boundaries are indicated explicitly with the `MSG_EOR` flag (Figure 16.12), so it is not necessary for the message boundaries to be preserved by `send`.

TCP applications have no control over the size of outgoing TCP segments. For example, a message of 4096 bytes sent on a TCP socket will be split by the socket layer into two mbufs with external clusters, containing 2048 bytes each, assuming there is enough space in the send buffer for 4096 bytes. Later, during protocol processing, TCP will segment the data according to the maximum segment size for the connection, which is normally less than 2048.

When a message is too large to fit in the available buffer space and the protocol allows messages to be split, `send` still does not pass data to the protocol until the free space in the buffer rises above `sb_lowat`. For TCP, `sb_lowat` defaults to 2048 (Figure 16.4), so this rule prevents the socket layer from bothering TCP with small chunks of data when the send buffer is nearly full.

### Unreliable Protocol Buffering

With unreliable protocols (e.g., UDP), no data is ever stored in the send buffer and no acknowledgment is ever expected. Each message is passed immediately to the protocol where it is queued for transmission on the appropriate network device. In this case, `sb_cc` is always 0, and `sb_hiwat` specifies the maximum size of each write and indirectly the maximum size of a datagram.

Figure 16.4 shows that `sb_hiwat` defaults to 9216 ( $9 \times 1024$ ) for UDP. Unless the process changes `sb_hiwat` with the `SO_SNDBUF` socket option, an attempt to write a datagram larger than 9216 bytes returns with an error. Even then, other limitations of the protocol implementation may prevent a process from sending large datagrams. Section 11.10 of Volume 1 discusses these defaults and limits in other TCP/IP implementations.

9216 is large enough for a NFS write, which often defaults to 8192 bytes of data plus protocol headers.

### sosend Code

Figure 16.22 shows an overview of the `sosend` function. We discuss the four shaded sections separately.

271-278 The arguments to `sosend` are: `so`, a pointer to the relevant socket; `addr`, a pointer to a destination address; `uio`, a pointer to a `uio` structure describing the I/O buffers in user space; `top`, an mbuf chain that holds data to be sent; `control`, an mbuf that holds control information to be sent; and `flags`, which contains options for this write call.

Normally, a process provides data to the socket layer through the `uio` mechanism and `top` is null. When the kernel itself is using the socket layer (such as with NFS), the data is passed to `sosend` as an mbuf chain pointed to by `top`, and `uio` is null.

279-304 The initialization code is described separately.

#### Lock send buffer

305-308 `sosend`'s main processing loop starts at `restart`, where it obtains a lock on the send buffer with `sblock` before proceeding. The lock ensures orderly access to the socket buffer by multiple processes.

If `MSG_DONTWAIT` is set in `flags`, then `SBLOCKWAIT` returns `M_NOWAIT`, which tells `sblock` to return `EWOULDBLOCK` if the lock is not available immediately.

`MSG_DONTWAIT` is used only by NFS in Net/3.

The main loop continues until `sosend` transfers all the data to the protocol (i.e., `resid == 0`).

#### Check for space

309-341 Before any data is passed to the protocol, various error conditions are checked and `sosend` implements the flow control and resource control algorithms described earlier. If `sosend` blocks waiting for more space to appear in the output buffer, it jumps back to `restart` before continuing.

#### Use data from top

342-350 Once space becomes available and `sosend` has obtained a lock on the send buffer, the data is prepared for delivery to the protocol layer. If `uio` is null (i.e., the data is in the mbuf chain pointed to by `top`), `sosend` checks `MSG_EOR` and sets `M_EOR` in the chain to mark the end of a logical record. The mbuf chain is ready for the protocol layer.

```

-----uipc_socket.c
271 sosen­d(so, addr, uio, top, control, flags)
272 struct socket *so;
273 struct mbuf *addr;
274 struct uio *uio;
275 struct mbuf *top;
276 struct mbuf *control;
277 int flags;
278 {
    /* initialization (Figure 16.23) */

305 restart:
306     if (error = sblock(&so->so_snd, SBLOCKWAIT(flags)))
307         goto out;
308     do {
        /* wait for space in send buffer (Figure 16.24) */

342         do {
343             if (uio == NULL) {
344                 /*
345                  * Data is prepackaged in "top".
346                  */
347                 resid = 0;
348                 if (flags & MSG_EOR)
349                     top->m_flags |= M_EOR;
350             } else
351                 do {
                    /* fill a single mbuf or an mbuf chain (Figure 16.25) */

396                     } while (space > 0 && atomic);

                    /* pass mbuf chain to protocol (Figure 16.26) */

412                 } while (resid && space > 0);
413             } while (resid);

414     release:
415         sbunlock(&so->so_snd);
416     out:
417         if (top)
418             m_freem(top);
419         if (control)
420             m_freem(control);
421         return (error);
422 }
-----uipc_socket.c

```

Figure 16.22 sosen­d function: overview.



ket.c

**Copy data from process**

351-396 When `uio` is not null, `sosend` must transfer the data from the process. When `PR_ATOMIC` is set (e.g., UDP), this loop continues until all the data has been stored in a single mbuf chain. A `break`, which is not shown in Figure 16.22, causes the loop to terminate when all the data has been copied from the process, and `sosend` passes the entire chain to the protocol.

When `PR_ATOMIC` is not set (e.g., TCP), this loop is executed only once, filling a single mbuf with data from `uio`. In this case, the mbufs are passed one at a time to the protocol.

**Pass data to the protocol**

397-413 For `PR_ATOMIC` protocols, after the mbuf chain is passed to the protocol, `resid` is always 0 and control falls through the two loops to `release`. When `PR_ATOMIC` is not set, `sosend` continues filling individual mbufs while there is more data to send and while there is still space in the buffer. If the buffer fills and there is still data to send, `sosend` loops back and waits for more space before filling the next mbuf. If all the data is sent, both loops terminate.

**Cleanup**

414-422 After all the data has been passed to the protocol, the socket buffer is unlocked, any remaining mbufs are discarded, and `sosend` returns.

The detailed description of `sosend` is shown in four parts:

- initialization (Figure 16.23),
- error and resource checking (Figure 16.24),
- data transfer (Figure 16.25), and
- protocol dispatch (Figure 16.26).

The first part of `sosend` shown in Figure 16.23 initializes various variables.

**Compute transfer size and semantics**

279-284 `atomic` is set if `sosendallatonce` is true (any protocol for which `PR_ATOMIC` is set) or the data has been passed to `sosend` as an mbuf chain in `top`. This flag controls whether data is passed to the protocol as a single mbuf chain or in separate mbufs.

285-297 `resid` is the number of bytes in the `iovec` buffers or the number of bytes in the `top` mbuf chain. Exercise 16.1 discusses why `resid` might be negative.

**If requested, disable routing**

298-303 `dontroute` is set when the routing tables should be bypassed for *this* message only. `clen` is the number of bytes in the optional control mbuf.

304 The macro `snderr` posts the error code, reenables protocol processing, and jumps to the cleanup code at `out`. This macro simplifies the error handling within the function.

cket.c

Figure 16.24 shows the part of `sosend` that checks for error conditions and waits for space to appear in the send buffer.

```

279 struct proc *p = curproc; /* XXX */
280 struct mbuf **mp;
281 struct mbuf *m;
282 long space, len, resid;
283 int clen = 0, error, s, dontroute, mlen;
284 int atomic = sosendallatonce(so) || top;

285 if (uio)
286     resid = uio->uio_resid;
287 else
288     resid = top->m_pkthdr.len;
289 /*
290  * In theory resid should be unsigned.
291  * However, space must be signed, as it might be less than 0
292  * if we over-committed, and we must use a signed comparison
293  * of space and resid. On the other hand, a negative resid
294  * causes us to loop sending 0-length segments to the protocol.
295  */
296 if (resid < 0)
297     return (EINVAL);
298 dontroute =
299     (flags & MSG_DONTROUTE) && (so->so_options & SO_DONTROUTE) == 0 &&
300     (so->so_proto->pr_flags & PR_ATOMIC);
301 p->p_stats->p_ru.ru_msgsnd++;
302 if (control)
303     clen = control->m_len;
304 #define snderr(errno) { error = errno; splx(s); goto release; }

```

Figure 16.23 sosend function: initialization.

309 Protocol processing is suspended to prevent the buffer from changing while it is being examined. Before each transfer, `sosend` checks several conditions:

- 310-311 • If output from the socket is prohibited (e.g., the write-half of a TCP connection has been closed), `EPIPE` is returned.
- 312-313 • If the socket is in an error state (e.g., an ICMP port unreachable may have been generated by a previous datagram), `so_error` is returned. `sendit` discards the error if some data has been sent before the error occurs (Figure 16.21, line 389).
- 314-318 • If the protocol requires connections and a connection has not been established or a connection attempt has not been started, `ENOTCONN` is returned. `sosend` permits a write consisting of control information and no data even when a connection has not been established.

The Internet protocols do not use this feature, but it is used by TP4 to send data with a connection request, to confirm a connection request, and to send data with a disconnect request.

- 319-321 • If a destination address is not specified for a connectionless protocol (e.g., the process calls `send` without establishing a destination with `connect`), `EDESTADDRREQ` is returned.

```

309     s = splnet();
310     if (so->so_state & SS_CANTSENDMORE)
311         snderr(EPIPE);
312     if (so->so_error)
313         snderr(so->so_error);
314     if ((so->so_state & SS_ISCONNECTED) == 0) {
315         if (so->so_proto->pr_flags & PR_CONNREQUIRED) {
316             if ((so->so_state & SS_ISCONFIRMING) == 0 &&
317                 !(resid == 0 && clen != 0))
318                 snderr(ENOTCONN);
319             } else if (addr == 0)
320                 snderr(EDESTADDRREQ);
321         }
322         space = sbspace(&so->so_snd);
323         if (flags & MSG_OOB)
324             space += 1024;
325         if (atomic && resid > so->so_snd.sb_hiwat ||
326             clen > so->so_snd.sb_hiwat)
327             snderr(EMSGSIZE);
328         if (space < resid + clen && uio &&
329             (atomic || space < so->so_snd.sb_lowat || space < clen)) {
330             if (so->so_state & SS_NBIO)
331                 snderr(EWOULDBLOCK);
332             sbunlock(&so->so_snd);
333             error = sbwait(&so->so_snd);
334             splx(s);
335             if (error)
336                 goto out;
337             goto restart;
338         }
339         splx(s);
340         mp = &top;
341         space -= clen;

```

Figure 16.24 sosend function: error and resource checking.

### Compute available space

322-324 sbspace computes the amount of free space remaining in the send buffer. This is an administrative limit based on the buffer's high-water mark, but is also limited by sb\_mbmax to prevent many small messages from consuming too many mbufs (Figure 16.6). sosend gives out-of-band data some priority by relaxing the limits on the buffer size by 1024 bytes.

### Enforce message size limit

325-327 If atomic is set and the message is larger than the high-water mark, EMSGSIZE is returned; the message is too large to be accepted by the protocol—even if the buffer were empty. If the control information is larger than the high-water mark, EMSGSIZE is also returned. This is the test that limits the size of a datagram or record.

**Wait for more space?**

328-329 If there is not enough space in the send buffer, the data is from a process (versus from the kernel in `top`), and one of the following conditions is true, then `sosend` must wait for additional space before continuing:

- the message must be passed to protocol in a single request (`atomic` is set), or
- the message may be split, but the free space has dropped below the low-water mark, or
- the message may be split, but the control information does not fit in the available space.

When the data is passed to `sosend` in `top` (i.e., when `uio` is null), the data is already located in mbufs. Therefore `sosend` ignores the high- and low-water marks since no additional mbuf allocations are required to pass the data to the protocol.

If the send buffer low-water mark is not used in this test, an interesting interaction occurs between the socket layer and the transport layer that leads to performance degradation. [Crowcroft et al. 1992] provides details on this scenario.

**Wait for space**

330-338 If `sosend` must wait for space and the socket is nonblocking, `EWOLDBLOCK` is returned. Otherwise, the buffer lock is released and `sosend` waits with `sbwait` until the status of the buffer changes. When `sbwait` returns, `sosend` reenables protocol processing and jumps back to `restart` to obtain a lock on the buffer and to check the error and space conditions again before continuing.

By default, `sbwait` blocks until data can be sent. By changing `sb_timeo` in the buffer through the `SO_SNDTIMEO` socket option, the process selects an upper bound for the wait time. If the timer expires, `sbwait` returns `EWOLDBLOCK`. Recall from Figure 16.21 that this error is discarded by `sendit` if some data has already been transferred to the protocol. This timer does not limit the length of the entire call, just the inactivity time between filling mbufs.

339-341 At this point, `sosend` has determined that some data may be passed to the protocol. `splx` enables interrupts since they should not be blocked during the relatively long time it takes to copy data from the process to the kernel. `mp` holds a pointer used to construct the mbuf chain. The size of the control information (`clen`) is subtracted from the space available before `sosend` transfers any data from the process.

Figure 16.25 shows the section of `sosend` that moves data from the process to one or more mbufs in the kernel.

**Allocate packet header or standard mbuf**

351-360 When `atomic` is set, this code allocates a packet header during the first iteration of the loop and standard mbufs afterwards. When `atomic` is not set, this code always allocates a packet header since `top` is always cleared before entering the loop.

```

351         do {
352             if (top == 0) {
353                 MGETHDR(m, M_WAIT, MT_DATA);
354                 mlen = MHLEN;
355                 m->m_pkthdr.len = 0;
356                 m->m_pkthdr.rcvif = (struct ifnet *) 0;
357             } else {
358                 MGET(m, M_WAIT, MT_DATA);
359                 mlen = MLEN;
360             }
361
362             if (resid >= MINCLSIZE && space >= MCLBYTES) {
363                 MCLGET(m, M_WAIT);
364                 if ((m->m_flags & M_EXT) == 0)
365                     goto nopages;
366                 mlen = MCLBYTES;
367                 if (atomic && top == 0) {
368                     len = min(MCLBYTES - max_hdr, resid);
369                     m->m_data += max_hdr;
370                 } else
371                     len = min(MCLBYTES, resid);
372                 space -= MCLBYTES;
373             } else {
374                 nopages:
375                 len = min(min(mlen, resid), space);
376                 space -= len;
377                 /*
378                  * For datagram protocols, leave room
379                  * for protocol headers in first mbuf.
380                  */
381                 if (atomic && top == 0 && len < mlen)
382                     MH_ALIGN(m, len);
383             }
384
385             error = uiomove(mtod(m, caddr_t), (int) len, uio);
386             resid = uio->uio_resid;
387             m->m_len = len;
388             *mp = m;
389             top->m_pkthdr.len += len;
390             if (error)
391                 goto release;
392             mp = &m->m_next;
393             if (resid <= 0) {
394                 if (flags & MSG_EOR)
395                     top->m_flags |= M_EOR;
396                 break;
397             }
398         } while (space > 0 && atomic);

```

*uipc\_socket.c**uipc\_socket.c*

Figure 16.25 sosend function: data transfer.

**If possible, use a cluster**

361-371 If the message is large enough to make a cluster allocation worthwhile and `space` is greater than or equal to `MCLBYTES`, a cluster is attached to the mbuf by `MCLGET`. When `space` is less than `MCLBYTES`, the extra 2048 bytes will break the allocation limit for the buffer since the entire cluster is allocated even if `resid` is less than `MCLBYTES`.

If `MCLGET` fails, `send` jumps to `no_pages` and uses a standard mbuf instead of an external cluster.

The test against `MINCLSIZE` should use `>`, not `>=`, since a write of 208 (`MINCLSIZE`) bytes fits within two mbufs.

When `atomic` is set (e.g., UDP), the mbuf chain represents a datagram or record and `max_hdr` bytes are reserved at the front of the *first* cluster for protocol headers. Subsequent clusters are part of the same chain and do not need room for the headers.

If `atomic` is not set (e.g., TCP), no space is reserved since `send` does not know how the protocol will segment the outgoing data.

Notice that `space` is decremented by the size of the cluster (2048 bytes) and not by `len`, which is the number of data bytes to be placed in the cluster (Exercise 16.2).

**Prepare the mbuf**

372-382 If a cluster was not used, the number of bytes stored in the mbuf is limited by the smaller of: (1) the space in the mbuf, (2) the number of bytes in the message, or (3) the space in the buffer.

When `atomic` is set, `MH_ALIGN` locates the data at the end of the buffer for the first buffer in the chain. `MH_ALIGN` is skipped if the data completely fills the mbuf. This may or may not leave enough room for protocol headers, depending on how much data is placed in the mbuf. When `atomic` is not set, no space is set aside for the headers.

**Get data from the process**

383-395 `uiomove` copies `len` bytes of data from the process to the mbuf. After the transfer, the mbuf length is updated, the previous mbuf is linked to the new mbuf (or `top` points to the first mbuf), and the length of the mbuf chain is updated. If an error occurred during the transfer, `send` jumps to `release`.

When the last byte is transferred from the process, `M_EOR` is set in the packet if the process set `MSG_EOR`, and `send` breaks out of this loop.

`MSG_EOR` applies only to protocols with explicit record boundaries such as TP4, from the OSI protocol suite. TCP does not support logical records and ignores the `MSG_EOR` flag.

**Fill another buffer?**

396 If `atomic` is set, `send` loops back and begins filling another mbuf.

The test for `space > 0` appears to be extraneous. `space` is irrelevant when `atomic` is not set since the mbufs are passed to the protocol one at a time. When `atomic` is set, this loop is entered only when there is enough space for the entire message. See also Exercise 16.2.

The last section of `send`, shown in Figure 16.26, passes the data and control mbufs to the protocol associated with the socket.

```

                                     uipc_socket.c
397     if (dontroute)
398         so->so_options |= SO_DONTRROUTE;
399     s = splnet(); /* XXX */
400     error = (*so->so_proto->pr_usrreq) (so,
401                                       (flags & MSG_OOB) ? PRU_SENDOOB : PRU_SEND,
402                                       top, addr, control);
403     splx(s);
404     if (dontroute)
405         so->so_options &= ~SO_DONTRROUTE;
406     clen = 0;
407     control = 0;
408     top = 0;
409     mp = &top;
410     if (error)
411         goto release;
412     ) while (resid && space > 0);
413     ) while (resid);
                                     uipc_socket.c

```

Figure 16.26 sosend function: protocol dispatch.

397-405 The socket's `SO_DONTRROUTE` option is toggled if necessary before and after passing the data to the protocol layer to bypass the routing tables on this message. This is the only option that can be enabled for a single message and, as described with Figure 16.23, it is controlled by the `MSG_DONTRROUTE` flag during a write.

`pr_usrreq` is bracketed with `splnet` and `splx` to block interrupts while the protocol is processing the message. This is a paranoid assumption since some protocols (such as UDP) may be able to do output processing without blocking interrupts, but this information is not available at the socket layer.

If the process tagged this message as out-of-band data, `sosend` issues the `PRU_SENDOOB` request; otherwise it issues the `PRU_SEND` request. Address and control mbufs are also passed to the protocol at this time.

406-413 `clen`, `control`, `top`, and `mp` are reset, since control information is passed to the protocol only once and a new mbuf chain is constructed for the next part of the message. `resid` is nonzero only when `atomic` is not set (e.g., TCP). In that case, if space remains in the buffer, `sosend` loops back to fill another mbuf. If there is no more space, `sosend` loops back to wait for more space (Figure 16.24).

We'll see in Chapter 23 that unreliable protocols, such as UDP, immediately queue the data for transmission on the network. Chapter 26 describes how reliable protocols, such as TCP, add the data to the socket's send buffer where it remains until it is sent to, and acknowledged by, the destination.

### sosend Summary

`sosend` is a complex function. It is 142 lines long, contains three nested loops, one loop implemented with `goto`, two code paths based on whether `PR_ATOMIC` is set or not, and two concurrency locks. As with much software, some of the complexity has accumulated over the years. NFS added the `MSG_DONTWAIT` semantics and the possibility

of receiving data from an mbuf chain instead of the buffers in a process. The `SS_ISCONFIRMING` state and `MSG_EOR` flag were introduced to handle the connection and record semantics of the OSI protocols.

A cleaner approach would be to implement a separate `sosend` function for each type of protocol and dispatch through a `pr_send` pointer in the `protosw` entry. This idea is suggested and implemented for UDP in [Partridge and Pink 1993].

### Performance Considerations

As described in Figure 16.25, `sosend`, when possible, passes message in mbuf-sized chunks to the protocol layer. While this results in more calls to the protocol than building and passing an entire mbuf chain, [Jacobson 1988a] reports that it improves performance by increasing parallelism.

Transferring one mbuf at a time (up to 2048 bytes) allows the CPU to prepare a packet while the network hardware is transmitting. Contrast this to sending a large mbuf chain: while the chain is being constructed, the network and the receiving system are idle. On the system described in [Jacobson 1988a], this change resulted in a 20% increase in network throughput.

It is important to make sure the send buffer is always larger than the bandwidth-delay product of a connection (Section 20.7 of Volume 1). For example, if TCP discovers that the connection can hold 20 segments before an acknowledgment is received, the send buffer must be large enough to hold the 20 unacknowledged segments. If it is too small, TCP will run out of data to send before the first acknowledgment is returned and the connection will be idle for some period of time.

## 16.8 `read`, `readv`, `recvfrom`, and `recvmsg` System Calls

These four system calls, which we refer to collectively as *read system calls*, receive data from a network connection. The first three system calls are simpler interfaces to the most general read system call, `recvmsg`. Figure 16.27 summarizes the features of the four read system calls and one library function (`recv`).

Function	Type of descriptor	Number of buffers	Return sender's address?	Flags?	Return control information?
<code>read</code>	any	1			
<code>readv</code>	any	[1..UIO_MAXIOV]			
<code>recv</code>	sockets only	1		•	
<code>recvfrom</code>	sockets only	1	•	•	
<code>recvmsg</code>	sockets only	[1..UIO_MAXIOV]	•	•	•

Figure 16.27 Read system calls.

In Net/3, `recv` is implemented as a library function that calls `recvfrom`. For binary compatibility with previously compiled programs, the kernel maps the old `recv` system call to the function `orecv`. We discuss only the kernel implementation of `recvfrom`.



The `read` and `readv` system calls are valid with any descriptor, but the remaining calls are valid only with socket descriptors.

As with the write calls, multiple buffers are specified by an array of `iovec` structures. For datagram protocols, `recvfrom` and `recvmsg` return the source address associated with each incoming datagram. For connection-oriented protocols, `getpeername` returns the address associated with the other end of the connection. The flags associated with the receive calls are shown in Section 16.11.

As with the write calls, the receive calls utilize a common function, in this case `soreceive`, to do all the work. Figure 16.28 illustrates the flow of control for the read system calls.

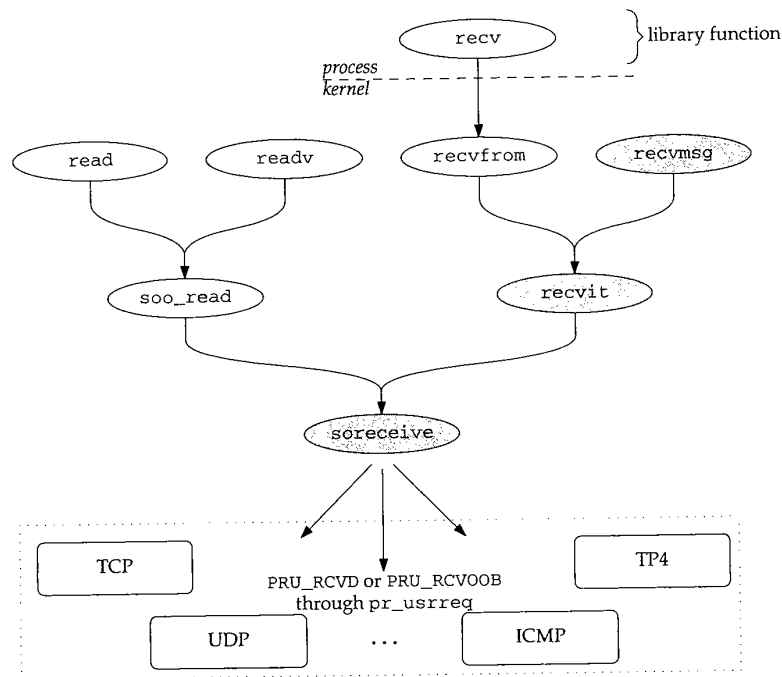

Figure 16.28 All socket input is processed by `soreceive`.

We discuss only the three shaded functions in Figure 16.28. The remaining functions are left for readers to investigate on their own.

## 16.9 recvmsg System Call

The `recvmsg` function is the most general read system call. Addresses, control information, and receive flags may be discarded without notification if a process uses one of the other read system calls while this information is pending. Figure 16.29 shows the `recvmsg` function.

```

433 struct recvmmsg_args {
434     int s;
435     struct msghdr *msg;
436     int flags;
437 };

438 recvmmsg(p, uap, retval)
439 struct proc *p;
440 struct recvmmsg_args *uap;
441 int *retval;
442 {
443     struct msghdr msg;
444     struct iovec aiov[UIO_SMALLIOV], *uiov, *iovp;
445     int error;

446     if (error = copyin((caddr_t) uap->msg, (caddr_t) & msg, sizeof(msg)))
447         return (error);
448     if ((u_int) msg.msg_iovlen >= UIO_SMALLIOV) {
449         if ((u_int) msg.msg_iovlen >= UIO_MAXIOV)
450             return (EMSGSIZE);
451         MALLOC(iovp, struct iovec *,
452             sizeof(struct iovec) * (u_int) msg.msg_iovlen, M_IOV,
453             M_WAITOK);
454     } else
455         iovp = aiov;
456     msg.msg_flags = uap->flags;
457     uiov = msg.msg_iov;
458     msg.msg_iov = iovp;
459     if (error = copyin((caddr_t) uiov, (caddr_t) iovp,
460         (unsigned) (msg.msg_iovlen * sizeof(struct iovec))))
461         goto done;
462     if ((error = recvit(p, uap->s, &msg, (caddr_t) 0, retval)) == 0) {
463         msg.msg_iov = uiov;
464         error = copyout((caddr_t) & msg, (caddr_t) uap->msg, sizeof(msg));
465     }
466     done:
467     if (iovp != aiov)
468         FREE(iovp, M_IOV);
469     return (error);
470 }

```

Figure 16.29 recvmmsg system call.

433-445 The three arguments to `recvmmsg` are: the socket descriptor; a pointer to a `msghdr` structure; and several control flags.

#### Copy iov array

446-461 As with `sendmsg`, `recvmmsg` copies the `msghdr` structure into the kernel, allocates a larger `iovec` array if the automatic array `aiov` is too small, and copies the array entries from the process into the kernel array pointed to by `iovp` (Section 16.4). The flags provided as the third argument are copied into the `msghdr` structure.

471-5

ills.c

**recvit and cleanup**

462-470 After `recvit` has received data, the `msghdr` structure is copied back into the process with the updated buffer lengths and flags. If a larger `iovec` structure was allocated, it is released before `recvmsg` returns.

**16.10 recvit Function**

The `recvit` function shown in Figures 16.30 and 16.31 is called from `recv`, `recvfrom`, and `recvmsg`. It prepares a `uio` structure for processing by `soreceive` based on the `msghdr` structure prepared by the `recvxxx` calls.

))

;

ls.c

dr

s a  
ies  
ro-

```

471 recvit(p, s, mp, namelenp, retsize)
472 struct proc *p;
473 int s;
474 struct msghdr *mp;
475 caddr_t namelenp;
476 int *retsize;
477 {
478     struct file *fp;
479     struct uio auio;
480     struct iovec *iovc;
481     int i;
482     int len, error;
483     struct mbuf *from = 0, *control = 0;
484     if (error = getsock(p->p_fd, s, &fp))
485         return (error);
486     auio.uio_iov = mp->msg_iov;
487     auio.uio_iovcnt = mp->msg_iovlen;
488     auio.uio_segflg = UIO_USERSPACE;
489     auio.uio_rw = UIO_READ;
490     auio.uio_procp = p;
491     auio.uio_offset = 0; /* XXX */
492     auio.uio_resid = 0;
493     iovc = mp->msg_iovc;
494     for (i = 0; i < mp->msg_iovlen; i++, iovc++) {
495         if (iovc->iov_len < 0)
496             return (EINVAL);
497         if ((auio.uio_resid += iovc->iov_len) < 0)
498             return (EINVAL);
499     }
500     len = auio.uio_resid;

```

*uipc\_syscalls.c*

*uipc\_syscalls.c*

**Figure 16.30** `recvit` function: initialize `uio` structure.

471-500 `getsock` returns the file structure for the descriptor `s`, and then `recvit` initializes the `uio` structure to describe a read transfer from the kernel to the process. The number of bytes to transfer is computed by summing the `msg_iovlen` members of the `iovec` array. The total is saved in `uio_resid` and in `len`.

The second half of `recvit`, shown in Figure 16.31, calls `soreceive` and copies the results back to the process.

```

                                     uipc_syscalls.c
501  if (error = soreceive((struct socket *) fp->f_data, &from, &auio,
502      (struct mbuf **) 0, mp->msg_control ? &control : (struct mbuf **) 0,
503      &mp->msg_flags)) {
504      if (auio.uio_resid != len && (error == ERESTART ||
505          error == EINTR || error == EWOULDBLOCK))
506          error = 0;
507  }
508  if (error)
509      goto out;
510  *retsize = len - auio.uio_resid;
511  if (mp->msg_name) {
512      len = mp->msg_namelen;
513      if (len <= 0 || from == 0)
514          len = 0;
515      else {
516          if (len > from->m_len)
517              len = from->m_len;
518          /* else if len < from->m_len ??? */
519          if (error = copyout(mtod(from, caddr_t),
520              (caddr_t) mp->msg_name, (unsigned) len))
521              goto out;
522      }
523      mp->msg_namelen = len;
524      if (namelenp &&
525          (error = copyout((caddr_t) &len, namelenp, sizeof(int)))) {
526          goto out;
527      }
528  }
529  if (mp->msg_control) {
530      len = mp->msg_controllen;
531      if (len <= 0 || control == 0)
532          len = 0;
533      else {
534          if (len >= control->m_len)
535              len = control->m_len;
536          else
537              mp->msg_flags |= MSG_CTRUNC;
538          error = copyout((caddr_t) mtod(control, caddr_t),
539              (caddr_t) mp->msg_control, (unsigned) len);
540      }
541      mp->msg_controllen = len;
542  }
543  out:
544  if (from)
545      m_freem(from);
546  if (control)
547      m_freem(control);
548  return (error);
549 }
                                     uipc_syscalls.c

```

501-510

511-542

543-549

16.11

Out-of-E

Figure 16.31 recvit function: return results.

**Call soreceive**

501-510 `soreceive` implements the complex semantics of receiving data from the socket buffers. The number of bytes transferred is saved in `*retsize` and returned to the process. When a signal arrives or a blocking condition occurs after some data has been copied to the process (`len` is not equal to `uio_resid`), the error is discarded and the partial transfer is reported.

**Copy address and control information to the process**

511-542 If the process provided a buffer for an address or control information or both, the buffers are filled and their lengths adjusted according to what `soreceive` returned. An address may be truncated if the buffer is too small. This can be detected by the process if it saves the buffer length before the read call and compares it with the value returned by the kernel in the `namelenp` variable (or in the length field of the `sockaddr` structure). Truncation of control information is reported by setting `MSG_CTRUNC` in `msg_flags`. See also Exercise 16.7.

**Cleanup**

543-549 At out, the mbufs allocated for the source address and the control information are released.

**16.11 soreceive Function**

This function transfers data from the receive buffer of the socket to the buffers specified by the process. Some protocols provide an address specifying the sender of the data, and this can be returned along with additional control information that may be present. Before examining the code, we need to discuss the semantics of a receive operation, out-of-band data, and the organization of a socket's receive buffer.

Figure 16.32 lists the flags that are recognized by the kernel during `soreceive`.

flags	Description	Reference
<code>MSG_DONTWAIT</code>	do not wait for resources during this call	Figure 16.38
<code>MSG_OOB</code>	receive out-of-band data instead of regular data	Figure 16.39
<code>MSG_PEEK</code>	receive a copy of the data without consuming it	Figure 16.43
<code>MSG_WAITALL</code>	wait for data to fill buffers before returning	Figure 16.50

Figure 16.32 `recvxxx` system calls: flag values passed to kernel.

`recvmsg` is the only read system call that returns flags to the process. In the other calls, the information is discarded by the kernel before control returns to the process. Figure 16.33 lists the flags that `recvmsg` can set in the `msg_hdr` structure.

**Out-of-Band Data**

Out-of-band (OOB) data semantics vary widely among protocols. In general, protocols expedite OOB data along a previously established communication link. The OOB data might not remain in sequence with previously sent regular data. The socket layer

msg_flags	Description	Reference
MSG_TRUNC	the control information received was larger than the buffer provided	Figure 16.31
MSG_EOR	the data received marks the end of a logical record	Figure 16.48
MSG_OOB	the buffer(s) contains out-of-band data	Figure 16.45
MSG_TRUNC	the message received was larger than the buffer(s) provided	Figure 16.51

Figure 16.33 `recvmsg` system call: `msg_flag` values returned by kernel.

supports two mechanisms to facilitate handling OOB data in a protocol-independent way: tagging and synchronization. In this chapter we describe the abstract OOB mechanisms implemented by the socket layer. UDP does not support OOB data. The relationship between TCP's urgent data mechanism and the socket OOB mechanism is described in the TCP chapters.

A sending process tags data as OOB data by setting the `MSG_OOB` flag in any of the `sendxxx` calls. `send` passes this information to the socket's protocol, which provides any special services, such as expediting the data or using an alternate queueing strategy.

When a protocol receives OOB data, the data is set aside instead of placing it in the socket's receive buffer. A process receives the pending OOB data by setting the `MSG_OOB` flag in one of the `recvxxx` calls. Alternatively, the receiving process can ask the protocol to place OOB data inline with the regular data by setting the `SO_OOBINLINE` socket option (Section 17.3). When `SO_OOBINLINE` is set, the protocol places incoming OOB data in the receive buffer with the regular data. In this case, `MSG_OOB` is not used to receive the OOB data. Read calls return either all regular data or all OOB data. The two types are never mixed in the input buffers of a single input system call. A process that uses `recvmsg` to receive data can examine the `MSG_OOB` flag to determine if the returned data is regular data or OOB data that has been placed inline.

The socket layer supports synchronization of OOB and regular data by allowing the protocol layer to mark the point in the regular data stream at which OOB data was received. The receiver can determine when it has reached this mark by using the `SIOCATMARK` `ioctl` command after each read system call. When receiving regular data, the socket layer ensures that only the bytes preceding the mark are returned in a single message so that the receiver does not inadvertently pass the mark. If additional OOB data is received before the receiver reaches the mark, the mark is silently advanced.

### Example

Figure 16.34 illustrates the two methods of receiving out-of-band data. In both examples, bytes A through I have been received as regular data, byte J as out-of-band data, and bytes K and L as regular data. The receiving process has accepted all data up to but not including byte A.

In the first example, the process can read bytes A through I or, if `MSG_OOB` is set, byte J. Even if the length of the read request is more than 9 bytes (A-I), the socket layer

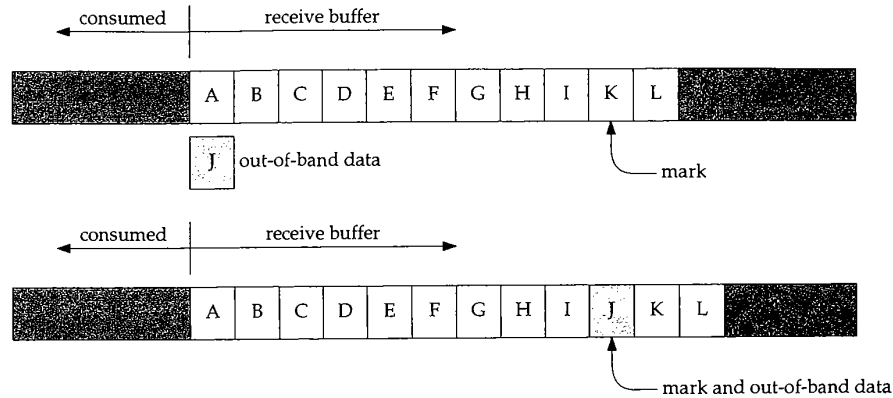

Figure 16.34 Receiving out-of-band data.

returns only 9 bytes to avoid passing the out-of-band synchronization mark. When byte I is consumed, `SIOCATMARK` is true; it is not necessary to consume byte J for the process to reach the out-of-band mark.

In the second example, the process can read only bytes A through I, at which point `SIOCATMARK` is true. A second call can read bytes J through L.

In Figure 16.34, byte J is *not* the byte identified by TCP's urgent pointer. The urgent pointer in this example would point to byte K. See Section 29.7 for details.

### Other Receive Options

A process can set the `MSG_PEEK` flag to retrieve data without consuming it. The data remains on the receive queue until a read system call without `MSG_PEEK` is processed.

The `MSG_WAITALL` flag indicates that the call should not return until enough data can be returned to fulfill the entire request. Even if `soreceive` has some data that can be returned to the process, it waits until additional data has been received.

When `MSG_WAITALL` is set, `soreceive` can return without filling the buffer in the following cases:

- the read-half of the connection is closed,
- the socket's receive buffer is smaller than the size of the read,
- an error occurs while the process is waiting for additional data,
- out-of-band data becomes available, or
- the end of a logical record occurs before the read buffer is filled.

NFS is the only software in Net/3 that uses the `MSG_WAITALL` and `MSG_DONTWAIT` flags. `MSG_DONTWAIT` can be set by a process to issue a nonblocking read system call without selecting nonblocking I/O with `ioctl` or `fcntl`.

### Receive Buffer Organization: Message Boundaries

For protocols that support message boundaries, each message is stored in a single chain of mbufs. Multiple messages in the receive buffer are linked together by `m_nextpkt` to form a queue of mbufs (Figure 2.21). The protocol processing layer adds data to the receive queue and the socket layer removes data from the receive queue. The high-water mark for a receive buffer restricts the amount of data that can be stored in the buffer.

When `PR_ATOMIC` is not set, the protocol layer stores as much data in the buffer as possible and discards the portion of the incoming data that does not fit. For TCP, this means that any data that arrives and is outside the receive window is discarded. When `PR_ATOMIC` is set, the entire message must fit within the buffer. If the message does not fit, the protocol layer discards the entire message. For UDP, this means that incoming datagrams are discarded when the receive buffer is full, probably because the process is not reading datagrams fast enough.

Protocols with `PR_ADDR` set use `sbappendaddr` to construct an mbuf chain and add it to the receive queue. The chain contains an mbuf with the source address of the message, 0 or more control mbufs, followed by 0 or more mbufs containing the data.

For `SOCK_SEQPACKET` and `SOCK_RDM` protocols, the protocol builds an mbuf chain for each record and calls `sbappendrecord` to append the record to the end of the receive buffer if `PR_ATOMIC` is set. If `PR_ATOMIC` is not set (OSI's TP4), a new record is started with `sbappendrecord`. Additional data is added to the record with `sbappend`.

It is not correct to assume that `PR_ATOMIC` indicates the buffer organization. For example, TP4 does not have `PR_ATOMIC` set, but supports record boundaries with the `M_EOR` flag.

Figure 16.35 illustrates the organization of a UDP receive buffer consisting of 3 mbuf chains (i.e., three datagrams). The `m_type` value for each mbuf is included.

In the figure, the third datagram has some control information associated with it. Three UDP socket options can cause control information to be placed in the receive buffer. See Figure 22.5 and Section 23.7 for details.

For `PR_ATOMIC` protocols, `sb_lowat` is ignored while data is being received. When `PR_ATOMIC` is not set, `sb_lowat` is the smallest number of bytes returned in a read system call. There are some exceptions to this rule, discussed with Figure 16.41.

### Receive Buffer Organization: No Message Boundaries

When the protocol does not maintain message boundaries (i.e., `SOCK_STREAM` protocols such as TCP), incoming data is appended to the end of the last mbuf chain in the buffer with `sbappend`. Incoming data is trimmed to fit within the receive buffer, and `sb_lowat` puts a lower bound on the number of bytes returned by a read system call.

Figure 16.36 illustrates the organization of a TCP receive buffer, which contains only regular data.



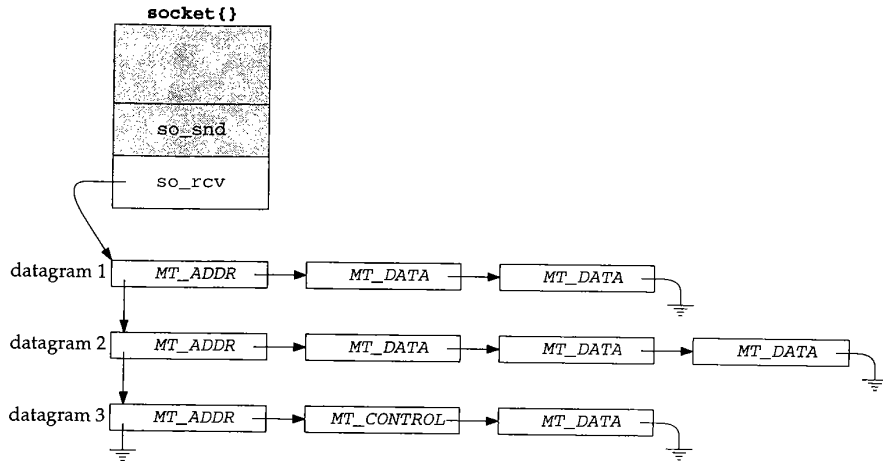

Figure 16.35 UDP receive buffer consisting of three datagrams.

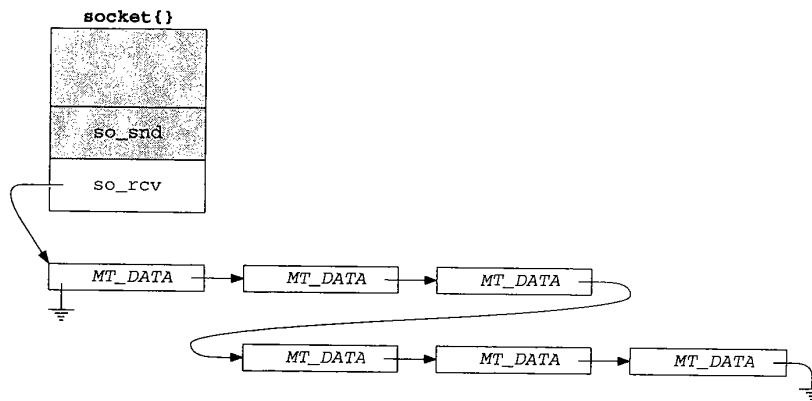

Figure 16.36 `so_rcv` buffer for TCP.

**Control Information and Out-of-band Data**

Unlike TCP, some stream protocols support control information and call `sbappendcontrol` to append the control information and the associated data as a new mbuf chain in the receive buffer. If the protocol supports inline OOB data, `sinsertoob` inserts a new mbuf chain just after any mbuf chain that contains OOB data, but before any mbuf chain with regular data. This ensures that incoming OOB data is queued ahead of any regular data.

Figure 16.37 illustrates the organization of a receive buffer that contains control information and OOB data.

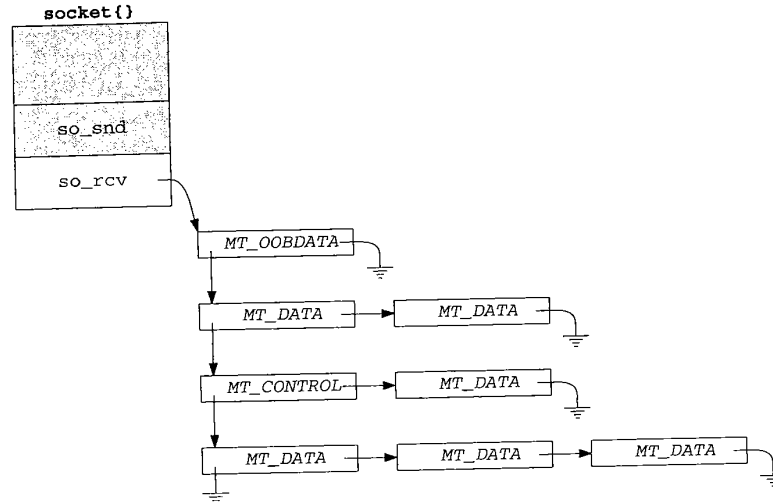

Figure 16.37 `so_rcv` buffer with control and OOB data.

The Unix domain stream protocol supports control information and the OSI TP4 protocol supports `MT_OOBDATA` mbufs. TCP does not support control data nor does it support the `MT_OOBDATA` form of out-of-band data. If the byte identified by TCP's urgent pointer is stored inline (`SO_OOBINLINE` is set), it appears as regular data, not OOB data. TCP's handling of the urgent pointer and the associated byte is described in Section 29.7.

## 16.12 `soreceive` Code

We now have enough background information to discuss `soreceive` in detail. While receiving data, `soreceive` must respect message boundaries, handle addresses and control information, and handle any special semantics identified by the read flags (Figure 16.32). The general rule is that `soreceive` processes one record per call and tries to return the number of bytes requested. Figure 16.38 shows an overview of the function.

439-446 `soreceive` has six arguments. `so` is a pointer to the socket. A pointer to an mbuf to receive address information is returned in `*paddr`. If `mp0` points to an mbuf pointer, `soreceive` transfers the receive buffer data to an mbuf chain pointed to by `*mp0`. In this case, the `uio` structure is used only for the count in `uio_resid`. If `mp0` is null, `soreceive` copies the data into buffers described by the `uio` structure. A pointer to the mbuf containing control information is returned in `*controlp`, and `soreceive` returns the flags described in Figure 16.33 in `*flagsp`.

rol

- 447-453 `soreceive` starts by setting `pr` to point to the socket's protocol switch structure and saving `uio_resid` (the size of the receive request) in `orig_resid`. If control information or addressing information is copied from the kernel to the process, `orig_resid` is set to 0. If data is copied, `uio_resid` is updated. In either case, `orig_resid` will not equal `uio_resid`. This fact is used at the end of `soreceive` (Figure 16.51).
- 454-461 `*paddr` and `*controlp` are cleared. The flags passed to `soreceive` in `*flagssp` are saved in `flags` after the `MSG_EOR` flag is cleared (Exercise 16.8). `flagssp` is a value-result argument, but only the `recvmsg` system call can receive the result flags. If `flagssp` is null, `flags` is set to 0.
- 483-487 Before accessing the receive buffer, `sblock` locks the buffer. `soreceive` waits for the lock unless `MSG_DONTWAIT` is set in `flags`.

This is another side effect of supporting calls to the socket layer from NFS within the kernel.

Protocol processing is suspended, so `soreceive` is not interrupted while it examines the buffer. `m` is the first mbuf on the first chain in the receive buffer.

#### If necessary, wait for data

- 488-541 `soreceive` checks several conditions and if necessary waits for more data to arrive in the buffer before continuing. If `soreceive` sleeps in this code, it jumps back to restart when it wakes up to see if enough data has arrived. This continues until the request can be satisfied.
- 542-545 `soreceive` jumps to `dontblock` when it has enough data to satisfy the request. A pointer to the second chain in the receive buffer is saved in `nextrecord`.

#### Process address and control information

- 546-590 Address information and control information are processed before any other data is transferred from the receive buffer.

#### Setup data transfer

- 591-597 Since only OOB data or regular data is transferred in a single call to `soreceive`, this code remembers the type of data at the front of the queue so `soreceive` can stop the transfer when the type changes.

#### Mbuf data transfer loop

- 598-692 This loop continues as long as there are mbufs in the buffer (`m` is not null), the requested number of bytes has not been transferred (`uio_resid > 0`), and no error has occurred.

#### Cleanup

- 693-719 The remaining code updates various pointers, flags, and offsets; releases the socket buffer lock; enables protocol processing; and returns.

P4  
it  
P's  
not  
in

file  
nd  
ig-  
to  
u.  
buf  
er,  
In  
all,  
to  
ve

```
uipc_socket.c
439 soreceive(so, paddr, uio, mp0, controlp, flagsp)
440 struct socket *so;
441 struct mbuf **paddr;
442 struct uio *uio;
443 struct mbuf **mp0;
444 struct mbuf **controlp;
445 int *flagsp;
446 {
447     struct mbuf *m, **mp;
448     int flags, len, error, s, offset;
449     struct protosw *pr = so->so_proto;
450     struct mbuf *nextrecord;
451     int moff, type;
452     int orig_resid = uio->uio_resid;

453     mp = mp0;
454     if (paddr)
455         *paddr = 0;
456     if (controlp)
457         *controlp = 0;
458     if (flagsp)
459         flags = *flagsp & ~MSG_EOR;
460     else
461         flags = 0;

        /* MSG_OOB processing and */
        /* implicit connection confirmation */

483 restart:
484     if (error = sblock(&so->so_rcv, SBLOCKWAIT(flags)))
485         return (error);
486     s = splnet();
487     m = so->so_rcv.sb_mb;

        /* if necessary, wait for data to arrive */

542 dontblock:
543     if (uio->uio_procp)
544         uio->uio_procp->p_stats->p_ru.ru_msgrcv++;
545     nextrecord = m->m_nextpkt;

        /* process address and control information */

591     if (m) {
592         if ((flags & MSG_PEEK) == 0)
593             m->m_nextpkt = nextrecord;
594         type = m->m_type;
595         if (type == MT_OOBDATA)
596             flags |= MSG_OOB;
597     }
```

```

/* process data */
693     } /* while more data and more space to fill */

/* cleanup */

715  release:
716      sbunlock(&so->so_rcv);
717      splx(s);
718      return (error);
719  }

```

*uipc\_socket.c*

Figure 16.38 soreceive function: overview.

In Figure 16.39, `soreceive` handles requests for OOB data.

```

462  if (flags & MSG_OOB) {
463      m = m_get(M_WAIT, MT_DATA);
464      error = (*pf->pf_usrreq) (so, PRU_RCVOOB,
465          m, (struct mbuf *) (flags & MSG_PEEK), (struct mbuf *) 0);
466      if (error)
467          goto bad;
468      do {
469          error = uiomove(mtod(m, caddr_t),
470              (int) min(uio->uio_resid, m->m_len), uio);
471          m = m_free(m);
472      } while (uio->uio_resid && error == 0 && m);
473  bad:
474      if (m)
475          m_freem(m);
476      return (error);
477  }

```

*uipc\_socket.c*

Figure 16.39 `soreceive` function: out-of-band data.

#### Receive OOB data

462-477 Since OOB data is not stored in the receive buffer, `soreceive` allocates a standard `mbuf` and issues the `PRU_RCVOOB` request to the protocol. The while loop copies any data returned by the protocol to the buffers specified by `uio`. After the copy, `soreceive` returns 0 or the error code.

UDP always returns `EOPNOTSUPP` for the `PRU_RCVOOB` request. See Section 30.2 for details regarding TCP urgent processing. In Figure 16.40, `soreceive` handles connection confirmation.

```

478     if (mp)
479         *mp = (struct mbuf *) 0;
480     if (so->so_state & SS_ISCONFIRMING && uio->uio_resid)
481         (*pr->pr_usrreq) (so, PRU_RCVD, (struct mbuf *) 0,
482             (struct mbuf *) 0, (struct mbuf *) 0);

```

— *uipc\_socket.c*

Figure 16.40 `soreceive` function: connection confirmation.**Connection confirmation**

478-482 If the data is to be returned in an mbuf chain, `*mp` is initialized to null. If the socket is in the `SO_ISCONFIRMING` state, the `PRU_RCVD` request notifies the protocol that the process is attempting to receive data.

The `SO_ISCONFIRMING` state is used only by the OSI stream protocol, TP4. In TP4, a connection is not considered complete until a user-level process has confirmed the connection by attempting to send or receive data. The process can reject a connection by calling `shutdown` or `close`, perhaps after calling `getpeername` to determine where the connection came from.

Figure 16.38 showed that the receive buffer is locked before it is examined by the code in Figure 16.41. This part of `soreceive` determines if the read system call can be satisfied by the data that is already in the receive buffer.

```

488     /*
489     * If we have less data than requested, block awaiting more
490     * (subject to any timeout) if:
491     * 1. the current count is less than the low water mark, or
492     * 2. MSG_WAITALL is set, and it is possible to do the entire
493     * receive operation at once if we block (resid <= hiwat).
494     * 3. MSG_DONTWAIT is not set
495     *
496     * If MSG_WAITALL is set but resid is larger than the receive buffer,
497     * we have to do the receive in sections, and thus risk returning
498     * a short count if a timeout or signal occurs after we start.
499     */
500     if (m == 0 || ((flags & MSG_DONTWAIT) == 0 &&
501         so->so_rcv.sb_cc < uio->uio_resid) &&
502         (so->so_rcv.sb_cc < so->so_rcv.sb_lowat ||
503         ((flags & MSG_WAITALL) && uio->uio_resid <= so->so_rcv.sb_hiwat)) &&
504         m->m_nextpkt == 0 && (pr->pr_flags & PR_ATOMIC) == 0) {

```

— *uipc\_socket.c*

Figure 16.41 `soreceive` function: enough data?**Can the call be satisfied now?**

488-504 The general rule for `soreceive` is that it waits until enough data is in the receive buffer to satisfy the entire read. There are several conditions that cause an error or less data than was requested to be returned.

If any of the following conditions are true, the process is put to sleep to wait for more data to arrive so the call can be satisfied:

socket.c

- There is no data in the receive buffer (`m` equals 0).
- There is not enough data to satisfy the entire read (`sb_cc < uio_resid` and `MSG_DONTWAIT` is not set), the minimum amount of data is *not* available (`sb_cc < sb_lowat`), and more data can be appended to this chain when it arrives (`m_nextpkt` is 0 and `PR_ATOMIC` is *not* set).

socket.c

- There is not enough data to satisfy the entire read, a minimum amount of data is available, data can be added to this chain, but `MSG_WAITALL` indicates that `soreceive` should wait until the entire read can be satisfied.

socket  
that the

If the conditions in the last case are met but the read is too large to be satisfied without blocking (`uio_resid > sb_hiwat`), `soreceive` continues without waiting for more data.

a connec-  
tion by  
shutdown  
ne from.

If there is some data in the buffer and `MSG_DONTWAIT` is set, `soreceive` does not wait for more data.

l by the  
ll can be

There are several reasons why waiting for more data may not be appropriate. In Figure 16.42, `soreceive` checks for these conditions and returns, or waits for more data to arrive.

#### Wait for more data?

c\_socket.c

505-534 At this point, `soreceive` has determined that it must wait for additional data to arrive before the read can be satisfied. Before waiting it checks for several additional conditions:

ffer,  
g

505-512 • If the socket is in an error state and *empty* (`m` is null), `soreceive` returns the error code. If there is an error and the receive buffer also contains data (`m` is nonnull), the data is returned and a subsequent read returns the error when there is no more data. If `MSG_PEEK` is set, the error is not cleared, since a read system call with `MSG_PEEK` set should not change the state of the socket.

513-518 • If the read-half of the connection has been closed and data remains in the receive buffer, `sosend` does not wait and returns the data to the process (at `dontblock`). If the receive buffer is empty, `soreceive` jumps to `release` and the read system call returns 0, which indicates that the read-half of the connection is closed.

t)) &&

519-523 • If the receive buffer contains out-of-band data or the end of a logical record, `soreceive` does not wait for additional data and jumps to `dontblock`.

nc\_socket.c

524-528 • If the protocol requires a connection and it does not exist, `ENOTCONN` is posted and the function jumps to `release`.

529-534 • If the read is for 0 bytes or nonblocking semantics have been selected, the function jumps to `release` and returns 0 or `EWOULDBLOCK`, respectively.

e receive  
or or less

#### Yes, wait for more data

wait for

535-541 `soreceive` has now determined that it must wait for more data, and that it is reasonable to do so (i.e., some data will arrive). The receive buffer is unlocked while the process sleeps in `sbwait`. If `sbwait` returns because of an error or a signal,

```

505         if (so->so_error) {
506             if (m)
507                 goto dontblock;
508             error = so->so_error;
509             if ((flags & MSG_PEEK) == 0)
510                 so->so_error = 0;
511             goto release;
512         }
513         if (so->so_state & SS_CANTRCVMORE) {
514             if (m)
515                 goto dontblock;
516             else
517                 goto release;
518         }
519         for (; m; m = m->m_next)
520             if (m->m_type == MT_OOBDATA || (m->m_flags & M_EOR)) {
521                 m = so->so_rcv.sb_mb;
522                 goto dontblock;
523             }
524         if ((so->so_state & (SS_ISCONNECTED | SS_ISCONNECTING)) == 0 &&
525             (so->so_proto->pr_flags & PR_CONNREQUIRED)) {
526             error = ENOTCONN;
527             goto release;
528         }
529         if (uio->uio_resid == 0)
530             goto release;
531         if ((so->so_state & SS_NBLOCK) || (flags & MSG_DONTWAIT)) {
532             error = EWOULDBLOCK;
533             goto release;
534         }
535         sbunlock(&so->so_rcv);
536         error = sbwait(&so->so_rcv);
537         splx(s);
538         if (error)
539             return (error);
540         goto restart;
541     }

```

Figure 16.42 soreceive function: wait for more data?

soreceive returns the error; otherwise the function jumps to restart to determine if the read can be satisfied now that more data has arrived.

As in `sosend`, a process can enable a receive timer for `sbwait` with the `SO_RCVTIMEO` socket option. If the timer expires before any data arrives, `sbwait` returns `EWOULDBLOCK`.

The effect of this timer is not what one would expect. Since the timer gets reset every time there is activity on the socket buffer, the timer never expires if at least 1 byte arrives within the timeout interval. This can delay the return of the read system call for more than the value of the timer. `sb_timeo` is an inactivity timer and does not put an upper bound on the amount of time that may be required to satisfy the read system call.



At this point, `soreceive` is prepared to transfer some data from the receive buffer. Figure 16.43 shows the transfer of any address information.

```

542 dontblock;
543     if (uio->uio_procp)
544         uio->uio_procp->p_stats->p_ru.ru_msgrcv++;
545     nextrecord = m->m_nextpkt;
546     if (pr->pr_flags & PR_ADDR) {
547         orig_resid = 0;
548         if (flags & MSG_PEEK) {
549             if (paddr)
550                 *paddr = m_copy(m, 0, m->m_len);
551             m = m->m_next;
552         } else {
553             sbfree(&so->so_rcv, m);
554             if (paddr) {
555                 *paddr = m;
556                 so->so_rcv.sb_mb = m->m_next;
557                 m->m_next = 0;
558                 m = so->so_rcv.sb_mb;
559             } else {
560                 MFREE(m, so->so_rcv.sb_mb);
561                 m = so->so_rcv.sb_mb;
562             }
563         }
564     }

```

*uipc\_socket.c*

*uipc\_socket.c*

Figure 16.43 `soreceive` function: return address information.

#### `dontblock`

542-545 `nextrecord` maintains a reference to the next record that appears in the receive buffer. This is used at the end of `soreceive` to attach the remaining mbufs to the socket buffer after the first chain has been discarded.

#### Return address information

546-564 If the protocol provides addresses, such as UDP, the mbuf containing the address is removed from the mbuf chain and returned in `*paddr`. If `paddr` is null, the address is discarded.

Throughout `soreceive`, if `MSG_PEEK` is set, the data is not removed from the buffer.

The code in Figure 16.44 processes any control mbufs that are in the buffer.

#### Return control information

565-590 Each control mbuf is removed from the buffer (or copied if `MSG_PEEK` is set) and attached to `*controlp`. If `controlp` is null, the control information is discarded.

If the process is prepared to receive control information, the protocol has a `dom_externalize` function defined, and if the control mbuf contains a `SCM_RIGHTS` (access rights) message, the `dom_externalize` function is called. This function takes any kernel action associated with receiving the access rights. Only the Unix protocol

```

565     while (m && m->m_type == MT_CONTROL && error == 0) {
566         if (flags & MSG_PEEK) {
567             if (controlp)
568                 *controlp = m_copy(m, 0, m->m_len);
569             m = m->m_next;
570         } else {
571             sbfree(&so->so_rcv, m);
572             if (controlp) {
573                 if (pr->pr_domain->dom_externalize &&
574                     mtod(m, struct cmsghdr *)->cmsg_type ==
575                     SCM_RIGHTS)
576                     error = (*pr->pr_domain->dom_externalize) (m);
577                 *controlp = m;
578                 so->so_rcv.sb_mb = m->m_next;
579                 m->m_next = 0;
580                 m = so->so_rcv.sb_mb;
581             } else {
582                 MFREE(m, so->so_rcv.sb_mb);
583                 m = so->so_rcv.sb_mb;
584             }
585         }
586         if (controlp) {
587             orig_resid = 0;
588             controlp = &(*controlp)->m_next;
589         }
590     }

```

Figure 16.44 soreceive function: control information.

domain supports access rights, as discussed in Section 7.3. If the process is not prepared to receive control information (`controlp` is null) the mbuf is discarded.

The loop continues while there are more mbufs with control information and no error has occurred.

For the Unix protocol domain, the `dom_externalize` function implements the semantics of passing file descriptors by modifying the file descriptor table of the receiving process.

After the control mbufs are processed, `m` points to the next mbuf on the chain. If the chain does not contain any mbufs after the address, or after the control information, `m` is null. This occurs, for example, when a 0-length UDP datagram is queued in the receive buffer. In Figure 16.45 `soreceive` prepares to transfer the data from the mbuf chain.

#### Prepare to transfer data

591-597 After the control mbufs have been processed, the chain should contain regular, out-of-band data mbufs or no mbufs at all. If `m` is null, `soreceive` is finished with this chain and control drops to the bottom of the `while` loop. If `m` is not null, any remaining chains (`nextrecord`) are reattached to `m` and the type of the next mbuf is saved in `type`. If the next mbuf contains OOB data, `MSG_OOB` is set in `flags`, which is later

ket.c

```

591     if (m) {
592         if ((flags & MSG_PEEK) == 0)
593             m->m_nextpkt = nextrecord;
594         type = m->m_type;
595         if (type == MT_OOBDATA)
596             flags |= MSG_OOB;
597     }

```

uipc\_socket.c

uipc\_socket.c

Figure 16.45 soreceive function: mbuf transfer setup.

returned to the process. Since TCP does not support the MT\_OOBDATA form of out-of-band data, MSG\_OOB will never be returned for reads on TCP sockets.

Figure 16.47 shows the first part of the mbuf transfer loop. Figure 16.46 lists the variables updated within the loop.

Variable	Description
moff	the offset of the next byte to transfer when MSG_PEEK is set
offset	the offset of the OOB mark when MSG_PEEK is set
uio_resid	the number of bytes remaining to be transferred
len	the number of bytes to be transferred from this mbuf; may be less than m_len if uio_resid is small, or if the OOB mark is near

et.c

Figure 16.46 soreceive function: loop variables.

598-600 During each iteration of the while loop, the data in a single mbuf is transferred to the output chain or to the uio buffers. The loop continues while there are more mbufs, the process's buffers are not full, and no error has occurred.

#### Check for transition between OOB and regular data

600-605 If, while processing the mbuf chain, the type of the mbuf changes, the transfer stops. This ensures that regular and out-of-band data are not both returned in the same message. This check does not apply to TCP.

#### Update OOB mark

606-611 The distance to the oobmark is computed and limits the size of the transfer, so the byte before the mark is the last byte transferred. The size of the transfer is also limited by the size of the mbuf. This code does apply to TCP.

612-625 If the data is being returned to the uio buffers, uiomove is called. If the data is being returned as an mbuf chain, uio\_resid is adjusted to reflect the number of bytes moved.

To avoid suspending protocol processing for a long time, protocol processing is enabled during the call to uiomove. Additional data may appear in the receive buffer because of protocol processing while uiomove is running.

The code in Figure 16.48 adjusts all the pointers and offsets to prepare for the next mbuf.

the  
is  
iveut-  
his  
ng  
in  
ter

```

598     moff = 0;
599     offset = 0;
600     while (m && uio->uio_resid > 0 && error == 0) {
601         if (m->m_type == MT_OOBDATA) {
602             if (type != MT_OOBDATA)
603                 break;
604         } else if (type == MT_OOBDATA)
605             break;
606         so->so_state &= ~SS_RCVATMARK;
607         len = uio->uio_resid;
608         if (so->so_oobmark && len > so->so_oobmark - offset)
609             len = so->so_oobmark - offset;
610         if (len > m->m_len - moff)
611             len = m->m_len - moff;
612         /*
613          * If mp is set, just pass back the mbufs.
614          * Otherwise copy them out via the uio, then free.
615          * Sockbuf must be consistent here (points to current mbuf,
616          * it points to next record) when we drop priority;
617          * we must note any additions to the sockbuf when we
618          * block interrupts again.
619          */
620         if (mp == 0) {
621             splx(s);
622             error = uiomove(mtod(m, caddr_t) + moff, (int) len, uio);
623             s = splnet();
624         } else
625             uio->uio_resid -= len;

```

Figure 16.47 soreceive function: uiomove.

**Finished with mbuf?**

626-646 If all the bytes in the mbuf have been transferred, the mbuf must be discarded or the pointers advanced. If the mbuf contained the end of a logical record, MSG\_EOR is set. If MSG\_PEEK is set, soreceive skips to the next buffer. If MSG\_PEEK is not set, the buffer is discarded if the data was copied by uiomove, or appended to mp if the data is being returned in an mbuf chain.

**More data to process**

647-657 There may be more data to process in the mbuf if the request didn't consume all the data, if so\_oobmark cut the request short, or if additional data arrived during uiomove. If MSG\_PEEK is set, moff is updated. If the data is to be returned on an mbuf chain, len bytes are copied and attached to the chain. The mbuf pointers and the receive buffer byte count are updated by the amount of data that was transferred.

Figure 16.49 contains the code that handles the OOB offset and the MSG\_EOR processing.

```

626         if (len == m->m_len - moff) {
627             if (m->m_flags & M_EOR)
628                 flags |= MSG_EOR;
629             if (flags & MSG_PEEK) {
630                 m = m->m_next;
631                 moff = 0;
632             } else {
633                 nextrecord = m->m_nextpkt;
634                 sbfree(&so->so_rcv, m);
635                 if (mp) {
636                     *mp = m;
637                     mp = &m->m_next;
638                     so->so_rcv.sb_mb = m = m->m_next;
639                     *mp = (struct mbuf *) 0;
640                 } else {
641                     MFREE(m, so->so_rcv.sb_mb);
642                     m = so->so_rcv.sb_mb;
643                 }
644                 if (m)
645                     m->m_nextpkt = nextrecord;
646             }
647         } else {
648             if (flags & MSG_PEEK)
649                 moff += len;
650             else {
651                 if (mp)
652                     *mp = m_copy(m, 0, len, M_WAIT);
653                 m->m_data += len;
654                 m->m_len -= len;
655                 so->so_rcv.sb_cc -= len;
656             }
657         }

```

uipc\_socket.c

Figure 16.48 soreceive function: update buffer.

```

658         if (so->so_oobmark) {
659             if ((flags & MSG_PEEK) == 0) {
660                 so->so_oobmark -= len;
661                 if (so->so_oobmark == 0) {
662                     so->so_state |= SS_RCVATMARK;
663                     break;
664                 }
665             } else {
666                 offset += len;
667                 if (offset == so->so_oobmark)
668                     break;
669             }
670         }
671         if (flags & MSG_EOR)
672             break;

```

uipc\_socket.c

Figure 16.49 soreceive function: out-of-band data mark.

**Update OOB mark**

658-670 If the out-of-band mark is nonzero, it is decremented by the number of bytes transferred. If the mark has been reached, `SS_RCVATMARK` is set and `soreceive` breaks out of the while loop. If `MSG_PEEK` is set, `offset` is updated instead of `so_oobmark`.

**End of logical record**

671-672 If the end of a logical record has been reached, `soreceive` breaks out of the mbuf processing loop so data from the next logical record is not returned with this message.

The loop in Figure 16.50 waits for more data to arrive when `MSG_WAITALL` is set and the request is not complete.

```

673          /*
674          * If the MSG_WAITALL flag is set (for non-atomic socket),
675          * we must not quit until "uio->uio_resid == 0" or an error
676          * termination. If a signal/timeout occurs, return
677          * with a short count but without error.
678          * Keep sockbuf locked against other readers.
679          */
680          while (flags & MSG_WAITALL && m == 0 && uio->uio_resid > 0 &&
681                !sosendallatonce(so) && !nextrecord) {
682              if (so->so_error || so->so_state & SS_CANTRCVMORE)
683                  break;
684              error = sbwait(&so->so_rcv);
685              if (error) {
686                  sbunlock(&so->so_rcv);
687                  splx(s);
688                  return (0);
689              }
690              if (m = so->so_rcv.sb_mb)
691                  nextrecord = m->m_nextpkt;
692          }
693      } /* while more data and more space to fill */

```

*uipc\_socket.c*

Figure 16.50 `soreceive` function: `MSG_WAITALL` processing.

**MSG\_WAITALL**

673-681 If `MSG_WAITALL` is set, there is no more data in the receive buffer (`m` equals 0), the caller wants more data, `sosendallatonce` is false, and this is the last record in the receive buffer (`nextrecord` is null), then `soreceive` must wait for additional data.

**Error or no more data will arrive**

682-683 If an error is pending or the connection is closed, the loop is terminated.

**Wait for data to arrive**

684-689 `sbwait` returns when the receive buffer is changed by the protocol layer. If the wait was interrupted by a signal (`error` is nonzero), `sosend` returns immediately.

**Synchronize `m` and `nextrecord` with receive buffer**

690-692 `m` and `nextrecord` are updated, since the receive buffer has been modified by the protocol layer. If data arrived in the mbuf, `m` will be nonzero and the `while` loop terminates.

**Process next mbuf**

693 This is the end of the mbuf processing loop. Control returns to the loop starting on line 600 (Figure 16.47). As long as there is data in the receive buffer, more space to fill, and no error has occurred, the loop continues.

When `soreceive` stops copying data, the code in Figure 16.51 is executed.

```

694     if (m && pr->pr_flags & PR_ATOMIC) {                               uipc_socket.c
695         flags |= MSG_TRUNC;
696         if ((flags & MSG_PEEK) == 0)
697             (void) sbdroprecord(&so->so_rcv);
698     }
699     if ((flags & MSG_PEEK) == 0) {
700         if (m == 0)
701             so->so_rcv.sb_mb = nextrecord;
702         if (pr->pr_flags & PR_WANTRCVD && so->so_pcb)
703             (*pr->pr_usrreq) (so, PRU_RCVD, (struct mbuf *) 0,
704                             (struct mbuf *) flags, (struct mbuf *) 0,
705                             (struct mbuf *) 0);
706     }
707     if (orig_resid == uio->uio_resid && orig_resid &&
708         (flags & MSG_EOR) == 0 && (so->so_state & SS_CANTRCVMORE) == 0) {
709         sbunlock(&so->so_rcv);
710         splx(s);
711         goto restart;
712     }
713     if (flagsp)
714         *flagsp |= flags;

```

Figure 16.51 `soreceive` function: cleanup.

**Truncated message**

694-698 If the process received a partial message (a datagram or a record) because its receive buffer was too small, the process is notified by setting `MSG_TRUNC` and the remainder of the message is discarded. `MSG_TRUNC` (as with all receive flags) is available only to a process through the `recvmsg` system call, even though `soreceive` always sets the flags.

**End of record processing**

699-706 If `MSG_PEEK` is not set, the next mbuf chain is attached to the receive buffer and, if required, the protocol is notified that the receive operation has been completed by issuing the `PRU_RCVD` protocol request. TCP uses this feature to update the receive window for the connection.

**Nothing transferred**

707-712 If `soreceive` runs to completion, no data is transferred, the end of a record is not reached, and the read-half of the connection is still active, then the buffer is unlocked and `soreceive` jumps back to restart to continue waiting for data.

713-714 Any flags set during `soreceive` are returned in `*flagsp`, the buffer is unlocked, and `soreceive` returns.

**Analysis**

`soreceive` is a complex function. Much of the complication is because of the intricate manipulation of pointers and the multiple types of data (out-of-band, address, control, regular) and multiple destinations (process buffers, mbuf chain).

Similar to `sosend`, `soreceive` has collected features over the years. A specialized receive function for each protocol would blur the boundary between the socket layer and the protocol layer, but it would simplify the code considerably.

[Partridge and Pink 1993] describe the creation of a custom `soreceive` function for UDP to checksum datagrams while they are copied from the receive buffer to the process. They note that modifying the generic `soreceive` function to support this feature would "make the already complicated socket routines even more complex."

**16.13 select System Call**

In the following discussion we assume that the reader is familiar with the basic operation and semantics of `select`. For a detailed discussion of the application interface to `select` see [Stevens 1992].

Figure 16.52 shows the conditions detected by using `select` to monitor a socket.

Description	Detected by selecting for:		
	reading	writing	exceptions
data available for reading	•		
read-half of connection is closed	•		
listen socket has queued connection	•		
socket error is pending	•		
space available for writing and a connection exists or is not required		•	
write-half of connection is closed		•	
socket error is pending		•	
OOB synchronization mark is pending			•

Figure 16.52 `select` system call: socket events.

We start with the first half of the `select` system call, shown in Figure 16.53.



**Validation and setup**

390-410 Two arrays of three descriptor sets are allocated on the stack: `ibits` and `obits`. They are cleared by `bzero`. The first argument, `nd`, must be no larger than the maximum number of descriptors associated with the process. If `nd` is more than the number of descriptors currently allocated to the process, it is reduced to the current allocation. `ni` is set to the number of bytes needed to store a bit mask with `nd` bits (1 bit for each descriptor). For example, if the maximum number of descriptors is 256 (`FD_SETSIZE`), `fd_set` is represented as an array of 32-bit integers (`NFDBITS`), and `nd` is 65, then:

$$ni = \text{howmany}(65, 32) \times 4 = 3 \times 4 = 12$$

where `howmany(x, y)` returns the number of `y`-bit objects required to store `x` bits.

**Copy file descriptor sets from process**

411-418 The `getbits` macro uses `copyin` to transfer the file descriptor sets from the process to the three descriptor sets in `ibits`. If a descriptor set pointer is null, nothing is copied from the process.

**Setup timeout value**

419-438 If `tv` is null, `timo` is set to 0 and `select` will wait indefinitely. If `tv` is not null, the timeout value is copied into the kernel and rounded up to the resolution of the hardware clock by `itimerfix`. The current time is added to the timeout value by `timevaladd`. The number of clock ticks until the timeout is computed by `hzto` and saved in `timo`. If the resulting timeout is 0, `timo` is set to 1. This prevents `select` from blocking and implements the nonblocking semantics of an all-0s `timeval` structure.

The second half of `select`, shown in Figure 16.54, scans the file descriptors indicated by the process and returns when one or more become ready, or the timer expires, or a signal occurs.

**Scan file descriptors**

439-442 The loop that starts at `retry` continues until `select` can return. The current value of the global integer `nselect` is saved and the `P_SELECT` flag is set in the calling process's control block. If either of these change while `selscan` (Figure 16.55) is checking the file descriptors, it indicates that the status of a descriptor has changed because of interrupt processing and `select` must rescan the descriptors. `selscan` looks at every descriptor set in the three input descriptor sets and sets the matching descriptor in the output set if the descriptor is ready.

**Error or some descriptors are ready**

443-444 Return immediately if an error occurred or if a descriptor is ready.

**Timeout expired?**

445-451 If the process supplied a time limit and the current time has advanced beyond the timeout value, return immediately.

```

390 struct select_args {
391     u_int  nd;
392     fd_set *in, *ou, *ex;
393     struct timeval *tv;
394 };

395 select(p, uap, retval)
396 struct proc *p;
397 struct select_args *uap;
398 int *retval;
399 {
400     fd_set  ibits[3], obits[3];
401     struct timeval atv;
402     int      s, ncoll, error = 0, timo;
403     u_int    ni;

404     bzero((caddr_t) ibits, sizeof(ibits));
405     bzero((caddr_t) obits, sizeof(obits));
406     if (uap->nd > FD_SETSIZE)
407         return (EINVAL);
408     if (uap->nd > p->p_fd->fd_nfiles)
409         uap->nd = p->p_fd->fd_nfiles; /* forgiving; slightly wrong */
410     ni = howmany(uap->nd, NFDBITS) * sizeof(fd_mask);

411 #define getbits(name, x) \
412     if (uap->name && \
413         (error = copyin((caddr_t)uap->name, (caddr_t)&ibits[x], ni)) \
414         goto done;
415     getbits(in, 0);
416     getbits(ou, 1);
417     getbits(ex, 2);
418 #undef getbits

419     if (uap->tv) {
420         error = copyin((caddr_t) uap->tv, (caddr_t) & atv,
421                     sizeof(atv));
422         if (error)
423             goto done;
424         if (itimerfix(&atv)) {
425             error = EINVAL;
426             goto done;
427         }
428         s = splclock();
429         timevaladd(&atv, (struct timeval *) &time);
430         timo = hzto(&atv);
431         /*
432          * Avoid inadvertently sleeping forever.
433          */
434         if (timo == 0)
435             timo = 1;
436         splx(s);
437     } else
438         timo = 0;

```

Figure 16.53 select function: initialization.

generic.c

```

439  retry:
440      ncoll = nselcoll;
441      p->p_flag |= P_SELECT;
442      error = selscan(p, ibits, obits, uap->nd, retval);
443      if (error || *retval)
444          goto done;
445      s = splhigh();
446      /* this should be timercmp(&time, &atv, >=) */
447      if (uap->tv && (time.tv_sec > atv.tv_sec ||
448          time.tv_sec == atv.tv_sec && time.tv_usec >= atv.tv_usec)) {
449          splx(s);
450          goto done;
451      }
452      if ((p->p_flag & P_SELECT) == 0 || nselcoll != ncoll) {
453          splx(s);
454          goto retry;
455      }
456      p->p_flag &= ~P_SELECT;
457      error = tsleep((caddr_t) & selwait, PSOCK | PCATCH, "select", timo);
458      splx(s);
459      if (error == 0)
460          goto retry;
461  done:
462      p->p_flag &= ~P_SELECT;
463      /* select is not restarted after signals... */
464      if (error == ERESTART)
465          error = EINTR;
466      if (error == EWOULDBLOCK)
467          error = 0;
468  #define putbits(name, x) \
469      if (uap->name && \
470          (error2 = copyout((caddr_t)&obits[x], (caddr_t)uap->name, ni))) \
471          error = error2;
472      if (error == 0) {
473          int    error2;
474          putbits(in, 0);
475          putbits(ou, 1);
476          putbits(ex, 2);
477  #undef putbits
478      }
479      return (error);
480 }

```

sys\_generic.c

sys\_generic.c

Figure 16.54 select function: second half.

generic.c

**Status changed during `selscan`**

452-455 `selscan` can be interrupted by protocol processing. If the socket is modified during the interrupt, `P_SELECT` and `nselect` are changed and `select` must rescan the descriptors.

**Wait for buffer changes**

456-460 All processes calling `select` use `selwait` as the wait channel when they call `tsleep`. With Figure 16.60 we show that this causes some inefficiencies if more than one process is waiting for the same socket buffer. If `tsleep` returns without an error, `select` jumps to retry to rescan the descriptors.

**Ready to return**

461-480 At done, `P_SELECT` is cleared, `ERESTART` is changed to `EINTR`, and `EWOULDBLOCK` is changed to 0. These changes ensure that `EINTR` is returned when a signal occurs during `select` and 0 is returned when a timeout occurs.

The output descriptor sets are copied back to the process and `select` returns.

**`selscan` Function**

The heart of `select` is the `selscan` function shown in Figure 16.55. For every bit set in one of the three descriptor sets, `selscan` computes the descriptor associated with the bit and dispatches control to the `fo_select` function associated with the descriptor. For sockets, this is the `soo_select` function.

**Locate descriptors to be monitored**

481-496 The first `for` loop iterates through each of the three descriptor sets: read, write, and exception. The second `for` loop iterates within each descriptor set. This loop is executed once for every 32 bits (`NFDBITS`) in the set.

The inner `while` loop checks all the descriptors identified by the 32-bit mask extracted from the current descriptor set and stored in `bits`. The function `ffs` returns the position within `bits` of the first 1 bit, starting at the low-order bit. For example, if `bits` is 1000 (with 28 leading 0s), `ffs(bits)` is 4.

**Poll descriptor**

497-500 From `i` and the return value of `ffs`, the descriptor associated with the bit is computed and stored in `fd`. The bit is cleared in `bits` (but not in the input descriptor set), the file structure associated with the descriptor is located, and `fo_select` is called.

The second argument to `fo_select` is one of the elements in the `flag` array. `msk` is the index of the outer `for` loop. So the first time through the loop, the second argument is `FREAD`, the second time it is `FWRITE`, and the third time it is 0. `EBADF` is returned if the descriptor is not valid.

**Descriptor is ready**

501-504 When a descriptor is found to be ready, the matching bit is set in the output descriptor set and `n` (the number of matches) is incremented.

505-510 The loops continue until all the descriptors are polled. The number of ready descriptors is returned in `*retval`.

```

481 selscan(p, ibits, obits, nfd, retval)
482 struct proc *p;
483 fd_set *ibits, *obits;
484 int nfd, *retval;
485 {
486     struct filedesc *fdp = p->p_fdp;
487     int msk, i, j, fd;
488     fd_mask bits;
489     struct file *fp;
490     int n = 0;
491     static int flag[3] =
492     {FREAD, FWRITE, 0};
493     for (msk = 0; msk < 3; msk++) {
494         for (i = 0; i < nfd; i += NFDBITS) {
495             bits = ibits[msk].fds_bits[i / NFDBITS];
496             while ((j = ffs(bits)) && (fd = i + --j) < nfd) {
497                 bits &= ~(1 << j);
498                 fp = fdp->fd_ofiles[fd];
499                 if (fp == NULL)
500                     return (EBADF);
501                 if ((*fp->f_ops->fo_select) (fp, flag[msk], p)) {
502                     FD_SET(fd, &obits[msk]);
503                     n++;
504                 }
505             }
506         }
507     }
508     *retval = n;
509     return (0);
510 }

```

*sys\_generic.c*

*sys\_generic.c*

Figure 16.55 selscan function.

### soo\_select Function

For every descriptor that `selscan` finds in the input descriptor sets, it calls the function referenced by the `fo_select` pointer in the `fileops` structure (Section 15.5) associated with the descriptor. In this text, we are interested only in socket descriptors and the `soo_select` function shown in Figure 16.56.

105-112 Each time `soo_select` is called, it checks the status of only one descriptor. If the descriptor is ready relative to the conditions specified in which, the function returns 1 immediately. If the descriptor is not ready, `selrecord` marks either the socket's receive or send buffer to indicate that a process is selecting on the buffer and then `soo_select` returns 0.

Figure 16.52 showed the read, write, and exceptional conditions for sockets. Here we see that the macros `soreadable` and `sowriteable` are consulted by `soo_select`. These macros are defined in `sys/socketvar.h`.

```

105 soo_select(fp, which, p)
106 struct file *fp;
107 int    which;
108 struct proc *p;
109 {
110     struct socket *so = (struct socket *) fp->f_data;
111     int    s = splnet();

112     switch (which) {

113     case FREAD:
114         if (soreadable(so)) {
115             splx(s);
116             return (1);
117         }
118         selrecord(p, &so->so_rcv.sb_sel);
119         so->so_rcv.sb_flags |= SB_SEL;
120         break;

121     case FWRITE:
122         if (sowriteable(so)) {
123             splx(s);
124             return (1);
125         }
126         selrecord(p, &so->so_snd.sb_sel);
127         so->so_snd.sb_flags |= SB_SEL;
128         break;

129     case 0:
130         if (so->so_oobmark || (so->so_state & SS_RCVATMARK)) {
131             splx(s);
132             return (1);
133         }
134         selrecord(p, &so->so_rcv.sb_sel);
135         so->so_rcv.sb_flags |= SB_SEL;
136         break;
137     }
138     splx(s);
139     return (0);
140 }

```

Figure 16.56 soo\_select function.

**Is socket readable?**

113-120 The soreadable macro is:

```

#define soreadable(so) \
    ((so)->so_rcv.sb_cc >= (so)->so_rcv.sb_lowat || \
     ((so)->so_state & SS_CANTRCVMORE) || \
     (so)->so_qlen || (so)->so_error)

```

Since the receive low-water mark for UDP and TCP defaults to 1 (Figure 16.4), the socket is readable if any data is in the receive buffer, if the read-half of the connection is closed, if any connections are ready to be accepted, or if there is an error pending.

**Is socket writeable?**

121-128 The `sowriteable` macro is:

```
#define sowriteable(so) \
    (sbspace(&(so)->so_snd) >= (so)->so_snd.sb_lowat && \
    (((so)->so_state&SS_ISCONNECTED) || \
    ((so)->so_proto->pr_flags&PR_CONNREQUIRED)==0) || \
    ((so)->so_state & SS_CANTSENDMORE) || \
    (so)->so_error)
```

The default send low-water mark for UDP and TCP is 2048. For UDP, `sowriteable` is always true because `sbspace` is always equal to `sb_hiwat`, which is always greater than or equal to `sb_lowat`, and a connection is not required.

For TCP, the socket is not writeable when the free space in the send buffer is less than 2048 bytes. The other cases are described in Figure 16.52.

**Are there any exceptional conditions pending?**

129-140 For exceptions, `so_oobmark` and the `SS_RCVATMARK` flags are examined. An exceptional condition exists until the process has read past the synchronization mark in the data stream.

**selrecord Function**

Figure 16.57 shows the definition of the `selinfo` structure stored with each send and receive buffer (the `sb_sel` member from Figure 16.3).

```
41 struct selinfo {
42     pid_t    si_pid;           /* process to be notified */
43     short    si_flags;       /* 0 or SI_COLL */
44 };
```

select.h

Figure 16.57 selinfo structure.

41-44 When only one process has called `select` for a given socket buffer, `si_pid` is the process ID of the waiting process. When additional processes call `select` on the same buffer, `SI_COLL` is set in `si_flags`. This is called a *collision*. This is the only flag currently defined for `si_flags`.

The `selrecord` function shown in Figure 16.58 is called when `soo_select` finds a descriptor that is not ready. The function records enough information so that the process is awakened by the protocol processing layer when the buffer changes.

**Already selecting on this descriptor**

522-531 The first argument to `selrecord` points to the `proc` structure for the selecting process. The second argument points to the `selinfo` record to update (`so_snd.sb_sel` or `so_rcv.sb_sel`). If this process is already recorded in the `selinfo` record for this socket buffer, the function returns immediately. For example, the process called `select` with the read and exception bits set for the same descriptor.

```

522 void
523 selrecord(selector, sip)
524 struct proc *selector;
525 struct selinfo *sip;
526 {
527     struct proc *p;
528     pid_t mypid;
529
529     mypid = selector->p_pid;
530     if (sip->si_pid == mypid)
531         return;
532     if (sip->si_pid && (p = pfind(sip->si_pid)) &&
533         p->p_wchan == (caddr_t) & selwait)
534         sip->si_flags |= SI_COLL;
535     else
536         sip->si_pid = mypid;
537 }

```

—sys\_generic.c

—sys\_generic.c

Figure 16.58 selrecord function.

**Select collision with another process?**

532–534 If another process is already selecting on this buffer, SI\_COLL is set.

**No collision**

535–537 If there is no other process already selecting on this buffer, si\_pid is 0 so the ID of the current process is saved in si\_pid.

**selwakeup Function**

When protocol processing changes the state of a socket buffer and only one process is selecting on the buffer, Net/3 can immediately put that process on the run queue based on the information it finds in the `selinfo` structure.

When the state changes and there is more than one process selecting on the buffer (SI\_COLL is set), Net/3 has no way of determining the set of processes interested in the buffer. When we discussed the code in Figure 16.54, we pointed out that *every* process that calls `select` uses `selwait` as the wait channel when calling `tsleep`. This means the corresponding wakeup will schedule *all* the processes that are blocked in `select`—even those that are not interested in activity on the buffer.

Figure 16.59 shows how `selwakeup` is called.

The protocol processing layer is responsible for notifying the socket layer by calling one of the functions listed at the bottom of Figure 16.59 when an event occurs that changes the state of a socket. The three functions shown at the bottom of Figure 16.59 cause `selwakeup` to be called and any process selecting on the socket to be scheduled to run.

`selwakeup` is shown in Figure 16.60.

541–548 If `si_pid` is 0, there is no process selecting on the buffer and the function returns immediately.



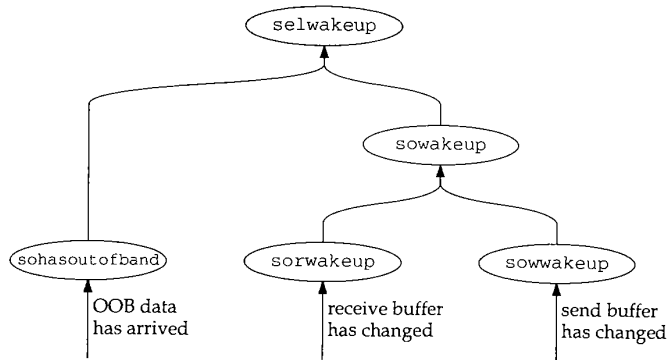

Figure 16.59 selwakeup processing.

```

541 void                                     sys_generic.c
542 selwakeup(sip)
543 struct selinfo *sip;
544 {
545     struct proc *p;
546     int s;

547     if (sip->si_pid == 0)
548         return;
549     if (sip->si_flags & SI_COLL) {
550         nselcoll++;
551         sip->si_flags &= ~SI_COLL;
552         wakeup((caddr_t) & selwait);
553     }
554     p = pfind(sip->si_pid);
555     sip->si_pid = 0;
556     if (p != NULL) {
557         s = splhigh();
558         if (p->p_wchan == (caddr_t) & selwait) {
559             if (p->p_stat == SSLEEP)
560                 setrunnable(p);
561             else
562                 unsleep(p);
563         } else if (p->p_flag & P_SELECT)
564             p->p_flag &= ~P_SELECT;
565         splx(s);
566     }
567 }

```

Figure 16.60 selwakeup function.

### Wake all processes during a collision

549-553 If more than one process is selecting on the affected socket, `nselect` is incremented, the collision flag is cleared, and every process blocked in `select` is awakened. As mentioned with Figure 16.54, `nselect` forces `select` to rescan the descriptors if the buffers change before the process has blocked in `tsleep` (Exercise 16.9).

554-567 If the process identified by `si_pid` is waiting on `selwait`, it is scheduled to run. If the process is waiting on some other wait channel, the `P_SELECT` flag is cleared. The process can be waiting on some other wait channel if `selrecord` is called for a valid descriptor and then `selscan` finds a bad file descriptor in one of the descriptor sets. `selscan` returns `EBADF`, but the previously modified `selinfo` record is not reset. Later, when `selwakeup` runs, `selwakeup` may find the process identified by `sel_pid` is no longer waiting on the socket buffer so the `selinfo` information is ignored.

Only one process is awakened during `selwakeup` unless multiple processes are sharing the same descriptor (i.e., the same socket buffers), which is rare. On the machines to which the authors had access, `nselect` was always 0, which confirms the statement that `select` collisions are rare.

## 16.14 Summary

In this chapter we looked at the read, write, and select system calls for sockets.

We saw that `sosend` handles all output between the socket layer and the protocol processing layer and that `soreceive` handles all input.

The organization of the send buffer and receive buffers was described, as well as the default values and semantics of the high-water and low-water marks for the buffers.

The last part of the chapter discussed the implementation of `select`. We showed that when only one process is selecting on a descriptor, the protocol processing layer will awaken only the process identified in the `selinfo` structure. When there is a collision and more than one process is selecting on a descriptor, the protocol layer has no choice but to awaken every process that is selecting on *any* descriptor.

### Exercises

- 16.1 What happens to `resid` in `sosend` when an unsigned integer larger than the maximum positive signed integer is passed in the `write` system call?
- 16.2 When `sosend` puts less than `MCLBYTES` of data in a cluster, `space` is reduced by the full `MCLBYTES` and may become negative, which terminates the loop that fills mbufs for atomic protocols. Is this a problem?
- 16.3 Datagram and stream protocols have very different semantics. Divide the `sosend` and `soreceive` functions each into two functions, one to handle messages, and one to handle streams. Other than making the code clearer, what are the advantages of making this change?
- 16.4 For `PR_ATOMIC` protocols, each write call specifies an implicit message boundary. The

socket layer delivers the message as a single unit to the protocol. The `MSG_EOR` flag allows a process to specify explicit message boundaries. Why is the implicit technique insufficient?

- 16.5 What happens when `send` cannot immediately acquire a lock on the send buffer when the socket descriptor is marked as nonblocking and the process does not specify `MSG_DONTWAIT`?
- 16.6 Under what circumstances would `sb_cc < sb_hiwat` yet `sbspace` would report no free space? Why should a process be blocked in this case?
- 16.7 Why isn't the length of a control message copied back to the process by `recvit` as is the name length?
- 16.8 Why does `recv` clear `MSG_EOR`?
- 16.9 What might happen if the `nselect` code were removed from `select` and `selwakeup`?
- 16.10 Modify the `select` system call to return the time remaining in the timer when `select` returns.



# 17

## Socket Options

### 17.1 Introduction

We complete our discussion of the socket layer in this chapter by discussing several system calls that modify the behavior of sockets.

The `setsockopt` and `getsockopt` system calls were introduced in Section 8.8, where we described the options that provide access to IP features. In this chapter we show the implementation of these two system calls and the socket-level options that are controlled through them.

The `ioctl` function was introduced in Section 4.4, where we described the protocol-independent `ioctl` commands for network interface configuration. In Section 6.7 we described the IP specific `ioctl` commands used to assign network masks as well as unicast, broadcast, and destination addresses. In this chapter we describe the implementation of `ioctl` and the related features of the `fcntl` function.

Finally, we describe the `getsockname` and `getpeername` system calls, which return address information for sockets and connections.

Figure 17.1 shows the functions that implement the socket option system calls. The shaded functions are described in this chapter.

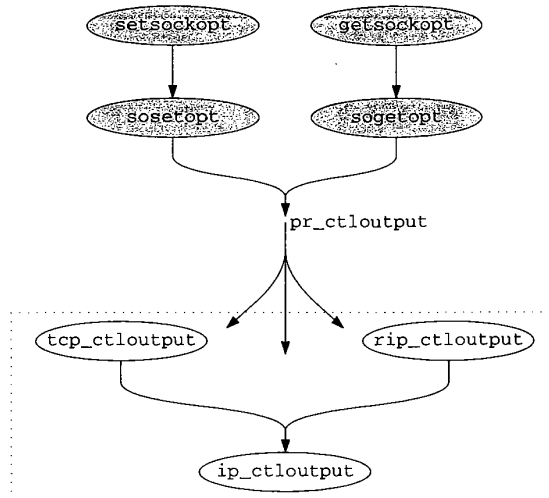

Figure 17.1 setsockopt and getsockopt system calls.

## 17.2 Code Introduction

The code in this chapter comes from the four files listed in Figure 17.2.

File	Description
kern/kern_descrip.c	fcntl system call
kern/uipc_syscalls.c	setsockopt, getsockopt, getsockname, and getpeername system calls
kern/uipc_socket.c	socket layer processing for setsockopt and getsockopt
kern/sys_socket.c	ioctl system call for sockets

Figure 17.2 Files discussed in this chapter.

### Global Variables and Statistics

No new global variables are introduced and no statistics are collected by the system calls we describe in this chapter.

### 17.3 setsockopt System Call

Figure 8.29 listed the different protocol levels that can be accessed with this function (and with `getsockopt`). In this chapter we focus on the `SOL_SOCKET` level options, which are listed in Figure 17.3.

<i>optname</i>	<i>optval</i> type	Variable	Description
<code>SO_SNDBUF</code>	int	<code>so_snd.sb_hiwat</code>	send buffer high-water mark
<code>SO_RCVBUF</code>	int	<code>so_rcv.sb_hiwat</code>	receive buffer high-water mark
<code>SO_SNDBUF</code>	int	<code>so_snd.sb_lowat</code>	send buffer low-water mark
<code>SO_RCVBUF</code>	int	<code>so_rcv.sb_lowat</code>	receive buffer low-water mark
<code>SO_SNDTIMEO</code>	struct timeval	<code>so_snd.sb_timeo</code>	send timeout
<code>SO_RCVTIMEO</code>	struct timeval	<code>so_rcv.sb_timeo</code>	receive timeout
<code>SO_DEBUG</code>	int	<code>so_options</code>	record debugging information for this socket
<code>SO_REUSEADDR</code>	int	<code>so_options</code>	socket can reuse a local address
<code>SO_REUSEPORT</code>	int	<code>so_options</code>	socket can reuse a local port
<code>SO_KEEPAIVE</code>	int	<code>so_options</code>	protocol probes idle connections
<code>SO_DONTROUTE</code>	int	<code>so_options</code>	bypass routing tables
<code>SO_BROADCAST</code>	int	<code>so_options</code>	socket allows broadcast messages
<code>SO_USELOOPBACK</code>	int	<code>so_options</code>	routing domain sockets only; sending process receives its own routing messages
<code>SO_OOBINLINE</code>	int	<code>so_options</code>	protocol queues out-of-band data inline
<code>SO_LINGER</code>	struct linger	<code>so_linger</code>	socket lingers on close
<code>SO_ERROR</code>	int	<code>so_error</code>	get error status and clear; <code>getsockopt</code> only
<code>SO_TYPE</code>	int	<code>so_type</code>	get socket type; <code>getsockopt</code> only
other			<code>ENOPROTOOPT</code> returned

Figure 17.3 setsockopt and getsockopt options.

The prototype for `setsockopt` is

```
int setsockopt(int s, int level, int optname, void *optval, int optlen);
```

Figure 17.4 shows the code for this system call.

565-597 `getsock` locates the file structure for the socket descriptor. If `val` is nonnull, `valsize` bytes of data are copied from the process into an mbuf allocated by `m_get`. The data associated with an option can be no more than `MLEN` bytes in length, so if `valsize` is larger than `MLEN`, then `EINVAL` is returned. `so_setopt` is called and its value is returned.

tem

```

565 struct setsockopt_args {
566     int     s;
567     int     level;
568     int     name;
569     caddr_t val;
570     int     valsize;
571 };

572 setsockopt(p, uap, retval)
573 struct proc *p;
574 struct setsockopt_args *uap;
575 int     *retval;
576 {
577     struct file *fp;
578     struct mbuf *m = NULL;
579     int     error;

580     if (error = getsock(p->p_fd, uap->s, &fp))
581         return (error);
582     if (uap->valsize > MLEN)
583         return (EINVAL);
584     if (uap->val) {
585         m = m_get(M_WAIT, MT_SOOPTS);
586         if (m == NULL)
587             return (ENOBUFS);
588         if (error = copyin(uap->val, mtod(m, caddr_t),
589             (u_int) uap->valsize)) {
590             (void) m_free(m);
591             return (error);
592         }
593         m->m_len = uap->valsize;
594     }
595     return (so_setopt((struct socket *) fp->f_data, uap->level,
596         uap->name, m));
597 }

```

Figure 17.4 setsockopt system call.

### so\_setopt Function

This function processes all the socket-level options and passes any other options to the `pr_ctloutput` function for the protocol associated with the socket. Figure 17.5 shows an overview of the function.

752-764 If the option is not for the socket level (`SOL_SOCKET`), the `PRCO_SETOPT` request is issued to the underlying protocol. Note that the protocol's `pr_ctloutput` function is being called and not its `pr_usrreq` function. Figure 17.6 shows which function is called for the Internet protocols.

765 The `switch` statement handles the socket-level options.

841-844 An unrecognized option causes `ENOPROTOPT` to be returned after the mbuf holding the option is released.



/syscalls.c

```

752 setsockopt(so, level, optname, m0)
753 struct socket *so;
754 int level, optname;
755 struct mbuf *m0;
756 {
757     int error = 0;
758     struct mbuf *m = m0;

759     if (level != SOL_SOCKET) {
760         if (so->so_proto && so->so_proto->pr_ctloutput)
761             return ((*so->so_proto->pr_ctloutput)
762                 (PRCO_SETOPT, so, level, optname, &m0));
763         error = ENOPROTOOPT;
764     } else {
765         switch (optname) {

/* socket option processing */

841         default:
842             error = ENOPROTOOPT;
843             break;
844         }
845         if (error == 0 && so->so_proto && so->so_proto->pr_ctloutput) {
846             (void) ((*so->so_proto->pr_ctloutput)
847                 (PRCO_SETOPT, so, level, optname, &m0));
848             m = NULL; /* freed by protocol */
849         }
850     }
851     bad:
852     if (m)
853         (void) m_free(m);
854     return (error);
855 }

```

uipc\_socket.c

uipc\_socket.c

/syscalls.c

Figure 17.5 setsockopt function.

Protocol	pr_ctloutput Function	Reference
UDP	ip_ctloutput	Section 8.8
TCP	tcp_ctloutput	Section 30.6
ICMP IGMP raw IP	rip_ctloutput and ip_ctloutput	Section 8.8 and Section 32.8

Figure 17.6 pr\_ctloutput functions.

845-855 Unless an error occurs, control always falls through the switch, where the option is passed to the associated protocol in case the protocol layer needs to respond to the request as well as the socket layer. None of the Internet protocols expect to process the socket-level options.

ns to the  
.5 shows

request is  
nction is  
nction is

buf hold-

Notice that the return value from the call to the `prctloutput` function is explicitly discarded in case the option is not expected by the protocol. `m` is set to null to avoid the call to `m_free`, since the protocol layer is responsible for releasing the `mbuf`.

Figure 17.7 shows the `linger` option and the options that set a single flag in the socket structure.

```

766         case SO_LINGER:
767             if (m == NULL || m->m_len != sizeof(struct linger)) {
768                 error = EINVAL;
769                 goto bad;
770             }
771             so->so_linger = mtod(m, struct linger *)->l_linger;
772             /* fall thru... */

773         case SO_DEBUG:
774         case SO_KEEPAVIVE:
775         case SO_DONTROUTE:
776         case SO_USELOOPBACK:
777         case SO_BROADCAST:
778         case SO_REUSEADDR:
779         case SO_REUSEPORT:
780         case SO_OOBINLINE:
781             if (m == NULL || m->m_len < sizeof(int)) {
782                 error = EINVAL;
783                 goto bad;
784             }
785             if (*mtod(m, int *))
786                 so->so_options |= optname;
787             else
788                 so->so_options &= ~optname;
789             break;

```

*uipc\_socket.c*

*uipc\_socket.c*

Figure 17.7 `so_setopt` function: `linger` and flag options.

766-772 The `linger` option expects the process to pass a `linger` structure:

```

struct linger {
    int    l_onoff;    /* option on/off */
    int    l_linger;  /* linger time in seconds */
};

```

After making sure the process has passed data and it is the size of a `linger` structure, the `l_linger` member is copied into `so_linger`. The option is enabled or disabled after the next set of case statements. `so_linger` was described in Section 15.15 with the `close` system call.

773-789 These options are boolean flags set when the process passes a nonzero value and cleared when 0 is passed. The first check makes sure an integer-sized object (or larger) is present in the `mbuf` and then sets or clears the appropriate option.

explicit  
to avoid

3 in the

socket.c

Figure 17.8 shows the socket buffer options.

```

790     case SO_SNDBUF:
791     case SO_RCVBUF:
792     case SO_SNDLOWAT:
793     case SO_RCVLOWAT:
794         if (m == NULL || m->m_len < sizeof(int)) {
795             error = EINVAL;
796             goto bad;
797         }
798         switch (optname) {
799
800         case SO_SNDBUF:
801         case SO_RCVBUF:
802             if (sbreserve(optname == SO_SNDBUF ?
803                 &so->so_snd : &so->so_rcv,
804                 (u_long) * mtod(m, int *)) == 0) {
805                 error = ENOBUFS;
806                 goto bad;
807             }
808             break;
809
810         case SO_SNDLOWAT:
811             so->so_snd.sb_lowat = *mtod(m, int *);
812             break;
813
814         case SO_RCVLOWAT:
815             so->so_rcv.sb_lowat = *mtod(m, int *);
816             break;
817         }
818     }
819     break;

```

*uipc\_socket.c*

*uipc\_socket.c*

Figure 17.8 setsockopt function: socket buffer options.

socket.c

790-815 This set of options changes the size of the send and receive buffers in a socket. The first test makes sure the required integer has been provided for all four options. For SO\_SNDBUF and SO\_RCVBUF, sbreserve adjusts the high-water mark but does no buffer allocation. For SO\_SNDLOWAT and SO\_RCVLOWAT, the low-water marks are adjusted.

Figure 17.9 shows the timeout options.

er struc-  
d or dis-  
ion 15.15

alue and  
r larger)

816-824 The timeout value for SO\_SNDTIMEO and SO\_RCVTIMEO is specified by the process in a timeval structure. If the right amount of data is not available, EINVAL is returned.

825-830 The time interval stored in the timeval structure must be small enough so that when it is represented as clock ticks, it fits within a short integer, since sb\_timeo is a short integer.

The code on line 826 is incorrect. The time interval cannot be represented as a short integer if:

```

816     case SO_SNDTIMEO:
817     case SO_RCVTIMEO:
818         {
819             struct timeval *tv;
820             short    val;
821
822             if (m == NULL || m->m_len < sizeof(*tv)) {
823                 error = EINVAL;
824                 goto bad;
825             }
826             tv = mtd(m, struct timeval *);
827             if (tv->tv_sec > SHRT_MAX / hz - hz) {
828                 error = EDOM;
829                 goto bad;
830             }
831             val = tv->tv_sec * hz + tv->tv_usec / tick;
832
833             switch (optname) {
834             case SO_SNDTIMEO:
835                 so->so_snd.sb_timeo = val;
836                 break;
837             case SO_RCVTIMEO:
838                 so->so_rcv.sb_timeo = val;
839                 break;
840             }

```

Figure 17.9 ssetopt function: timeout options.

$$tv\_sec \times hz + \frac{tv\_usec}{tick} > SHRT\_MAX$$

where

$$tick = \frac{1,000,000}{hz} \text{ and } SHRT\_MAX = 32767$$

So EDOM should be returned if

$$tv\_sec > \frac{SHRT\_MAX}{hz} - \frac{tv\_usec}{tick \times hz} = \frac{SHRT\_MAX}{hz} - \frac{tv\_usec}{1,000,000}$$

The last term in this equation is not hz as specified in the code. The correct test is

```
if (tv->tv_sec*hz + tv->tv_usec/tick > SHRT_MAX)
```

but see Exercise 17.3 for more discussion.

831-840 The converted time, val, is saved in the send or receive buffer as requested. sb\_timeo limits the amount of time a process will wait for data in the receive buffer or space in the send buffer. See Sections 16.7 and 16.12 for details.

The timeout values are passed as the last argument to `tsleep`, which expects an integer, so the process is limited to 65535 ticks. At 100 Hz, this less than 11 minutes.

## 17.4 getsockopt System Call

`getsockopt` returns socket and protocol options as requested. The prototype for this system call is

```
int getsockopt(int s, int level, int name, caddr_t val, int *valsize);
```

The code is shown in Figure 17.10.

```

-----uipc_syscalls.c
598 struct getsockopt_args {
599     int     s;
600     int     level;
601     int     name;
602     caddr_t val;
603     int     *avalsize;
604 };

605 getsockopt(p, uap, retval)
606 struct proc *p;
607 struct getsockopt_args *uap;
608 int     *retval;
609 {
610     struct file *fp;
611     struct mbuf *m = NULL;
612     int     valsize, error;

613     if (error = getsock(p->p_fd, uap->s, &fp))
614         return (error);
615     if (uap->val) {
616         if (error = copyin((caddr_t) uap->avalsize, (caddr_t) & valsize,
617                             sizeof(valsize)))
618             return (error);
619     } else
620         valsize = 0;
621     if ((error = sogetopt((struct socket *) fp->f_data, uap->level,
622                          uap->name, &m)) == 0 && uap->val && valsize && m != NULL) {
623         if (valsize > m->m_len)
624             valsize = m->m_len;
625         error = copyout(mtod(m, caddr_t), uap->val, (u_int) valsize);
626         if (error == 0)
627             error = copyout((caddr_t) & valsize,
628                             (caddr_t) uap->avalsize, sizeof(valsize));
629     }
630     if (m != NULL)
631         (void) m_free(m);
632     return (error);
633 }
-----uipc_syscalls.c

```

Figure 17.10 `getsockopt` system call.

598-633 The code should look pretty familiar by now. `getsock` locates the socket, the size of the option buffer is copied into the kernel, and `sogetopt` is called to get the value of the requested option. The data returned by `sogetopt` is copied out to the buffer in the process along with the possibly new length of the buffer. It is possible that the data will

be silently truncated if the process did not provide a large enough buffer. As usual, the mbuf holding the option data is released before the function returns.

### sogetopt Function

As with `so_setopt`, the `so_getopt` function handles the socket-level options and passes any other options to the protocol associated with the socket. The beginning and end of the function are shown in Figure 17.11.

```

856 sogetopt(so, level, optname, mp)
857 struct socket *so;
858 int level, optname;
859 struct mbuf **mp;
860 {
861     struct mbuf *m;

862     if (level != SOL_SOCKET) {
863         if (so->so_proto && so->so_proto->pr_ctloutput) {
864             return ((*so->so_proto->pr_ctloutput)
865                 (PRCO_GETOPT, so, level, optname, mp));
866         } else
867             return (ENOPROTOOPT);
868     } else {
869         m = m_get(M_WAIT, MT_SOOPTS);
870         m->m_len = sizeof(int);
871         switch (optname) {

/* socket option processing */

918         default:
919             (void) m_free(m);
920             return (ENOPROTOOPT);
921         }
922         *mp = m;
923         return (0);
924     }
925 }

```

Figure 17.11 `sogetopt` function: overview.

856-871 As with `so_setopt`, options that do not pertain to the socket level are immediately passed to the protocol level through the `PRCO_GETOPT` protocol request. The protocol returns the requested option in the mbuf pointed to by `*mp`.

For socket-level options, a standard mbuf is allocated to hold the option value, which is normally an integer, so `m_len` is set to the size of an integer. The appropriate option is copied into the mbuf by the code in the switch statement.

918-925 If the default case is taken by the switch, the mbuf is released and `ENOPROTOOPT` returned. Otherwise, after the switch statement, the pointer to the

l, the

mbuf is saved in *\*mp*. When this function returns, *getsockopt* copies the option from the mbuf to the process and releases the mbuf.

In Figure 17.12 the linger option and the options that are implemented as boolean flags are processed.

asses  
nd of

socket.c

```

872         case SO_LINGER:
873             m->m_len = sizeof(struct linger);
874             mtod(m, struct linger *)->l_onoff =
875                 so->so_options & SO_LINGER;
876             mtod(m, struct linger *)->l_linger = so->so_linger;
877             break;

878         case SO_USELOOPBACK:
879         case SO_DONTROUTE:
880         case SO_DEBUG:
881         case SO_KEEPAVAIL:
882         case SO_REUSEADDR:
883         case SO_REUSEPORT:
884         case SO_BROADCAST:
885         case SO_OOBINLINE:
886             *mtod(m, int *) = so->so_options & optname;
887             break;

```

Figure 17.12 *sogetopt* function: *SO\_LINGER* and boolean options.

872-877 The *SO\_LINGER* option requires two copies, one for the flag into *l\_onoff* and a second for the linger time into *l\_linger*.

878-887 The remaining options are implemented as boolean flags. *so\_options* is masked with *optname*, which results in a nonzero value if the option is on and 0 if the option is off. Notice that the return value is not necessarily 1 when the flag is on.

In the next part of *sogetopt* (Figure 17.13), the integer-valued options are copied into the mbuf.

socket.c

diately  
rotocolvalue,  
opriated and  
to the

```

888         case SO_TYPE:
889             *mtod(m, int *) = so->so_type;
890             break;

891         case SO_ERROR:
892             *mtod(m, int *) = so->so_error;
893             so->so_error = 0;
894             break;

895         case SO_SNDBUF:
896             *mtod(m, int *) = so->so_snd.sb_hiwat;
897             break;

898         case SO_RCVBUF:
899             *mtod(m, int *) = so->so_rcv.sb_hiwat;
900             break;

```

```

901     case SO_SNDLOWAT:
902         *mtod(m, int *) = so->so_snd.sb_lowat;
903         break;
904     case SO_RCVLOWAT:
905         *mtod(m, int *) = so->so_rcv.sb_lowat;
906         break;

```

*uipc\_socket.c*

Figure 17.13 `sogetopt` function: integer valued options.

888-906 Each option is copied as an integer into the mbuf. Notice that some of the options are stored as shorts in the kernel (e.g., the high-water and low-water marks) but returned as integers. Also, `so_error` is cleared once the value is copied into the mbuf. This is the only time that a call to `getsockopt` changes the state of the socket.

The fourth and last part of `sogetopt` is shown in Figure 17.14, where the `SO_SNDTIMEO` and `SO_RCVTIMEO` options are handled.

```

907     case SO_SNDTIMEO:
908     case SO_RCVTIMEO:
909     {
910         int    val = (optname == SO_SNDTIMEO ?
911                     so->so_snd.sb_timeo : so->so_rcv.sb_timeo);
912
913         m->m_len = sizeof(struct timeval);
914         mtod(m, struct timeval *)->tv_sec = val / hz;
915         mtod(m, struct timeval *)->tv_usec =
916             (val % hz) / tick;
917         break;
918     }

```

*uipc\_socket.c*

Figure 17.14 `sogetopt` function: timeout options.

907-917 The `sb_timeo` value from the send or receive buffer is copied into `val`. A `timeval` structure is constructed in the mbuf based on the clock ticks in `val`.

There is a bug in the calculation of `tv_usec`. The expression should be `"(val % hz) * tick"`.

## 17.5 `fcntl` and `ioctl` System Calls

Due more to history than intent, several features of the sockets API can be accessed from either `ioctl` or `fcntl`. We have already discussed many of the `ioctl` commands and have mentioned `fcntl` several times.

Figure 17.15 highlights the functions described in this chapter.



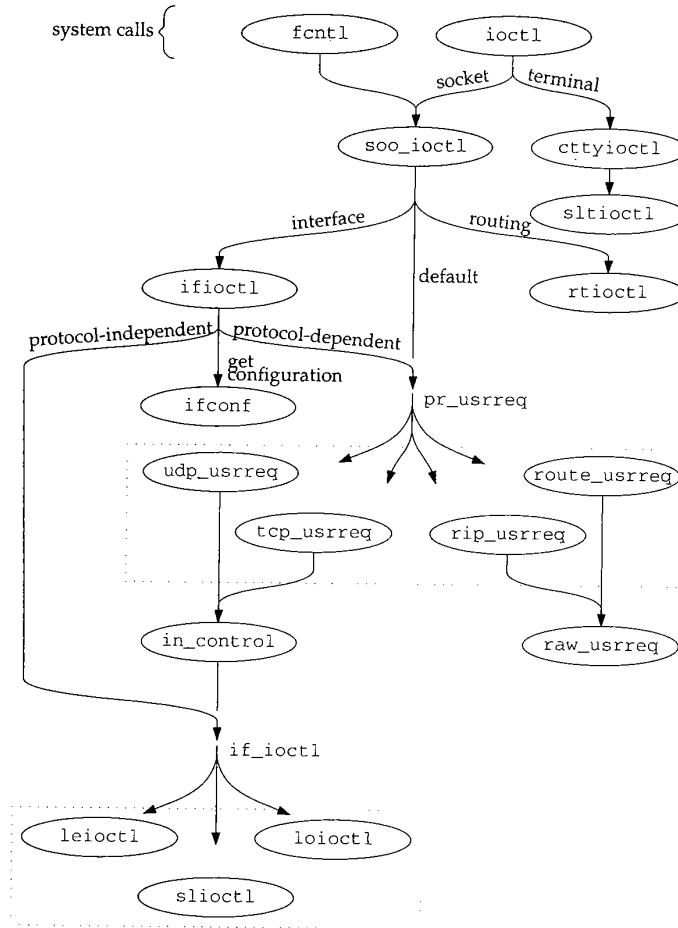

Figure 17.15 fcntl and ioctl functions.

The prototypes for ioctl and fcntl are:

```
int ioctl(int fd, unsigned long result, char *argp);
```

```
int fcntl(int fd, int cmd, ... /* int arg */);
```

Figure 17.16 summarizes the features of these two system calls as they relate to sockets. We show the traditional constants in Figure 17.16, since they appear in the code. For Posix compatibility, O\_NONBLOCK can be used instead of FNONBLOCK, and O\_ASYNC can be used instead of FASYNC.

Description	fcntl	ioctl
enable or disable nonblocking semantics by turning <code>SS_NBIO</code> on or off in <code>so_state</code>	FNONBLOCK file status flag	FIONBIO command
enable or disable asynchronous notification by turning <code>SB_ASYNC</code> on or off in <code>sb_flags</code>	FASYNC file status flag	FIOASYNC command
set or get <code>so_pgid</code> , which is the target process or process group for <code>SIGIO</code> and <code>SIGURG</code> signals	F_SETOWN or F_GETOWN	SIOCSGRP or SIOCGGRP commands
get number of bytes in receive buffer; return <code>so_rcv.sb_cc</code>		FIONREAD
return OOB synchronization mark; the <code>SS_RCVATMARK</code> flag in <code>so_state</code>		STOCCATMARK

Figure 17.16 fcntl and ioctl commands.

**fcntl Code**

Figure 17.17 shows an overview of the fcntl function.

```

133 struct fcntl_args {
134     int    fd;
135     int    cmd;
136     int    arg;
137 };
138 /* ARGSUSED */
139 fcntl(p, uap, retval)
140 struct proc *p;
141 struct fcntl_args *uap;
142 int    *retval;
143 {
144     struct filedesc *fdp = p->p_fdp;
145     struct file *fp;
146     struct vnode *vp;
147     int    i, tmp, error, flg = F_POSIX;
148     struct flock fl;
149     u_int  newmin;
150     if ((unsigned) uap->fd >= fdp->fd_nfiles ||
151         (fp = fdp->fd_ofiles[uap->fd]) == NULL)
152         return (EBADF);
153     switch (uap->cmd) {
154
155                                     /* command processing */
156
157     default:
158         return (EINVAL);
159     }
160     /* NOTREACHED */
161 }

```

*kern\_descrip.c*

*kern\_descrip.c*

Figure 17.17 fcntl system call: overview.

- 133-153 After verifying that the descriptor refers to an open file, the switch statement processes the requested command.
- 253-257 If the command is not recognized, fcntl returns EINVAL.

Figure 17.18 shows only the cases from fcntl that are relevant to sockets.

```

                                                                    kern_descrip.c
168     case F_GETFL:
169         *retval = OFLAGS(fp->f_flag);
170         return (0);
171     case F_SETFL:
172         fp->f_flag &= ~FCNTLFLAGS;
173         fp->f_flag |= FFLAGS(uap->arg) & FCNTLFLAGS;
174         tmp = fp->f_flag & FNONBLOCK;
175         error = (*fp->f_ops->fo_ioctl) (fp, FIONBIO, (caddr_t) & tmp, p);
176         if (error)
177             return (error);
178         tmp = fp->f_flag & FASYNC;
179         error = (*fp->f_ops->fo_ioctl) (fp, FIOASYNC, (caddr_t) & tmp, p);
180         if (!error)
181             return (0);
182         fp->f_flag &= ~FNONBLOCK;
183         tmp = 0;
184         (void) (*fp->f_ops->fo_ioctl) (fp, FIONBIO, (caddr_t) & tmp, p);
185         return (error);
186     case F_GETOWN:
187         if (fp->f_type == DTYPE_SOCKET) {
188             *retval = ((struct socket *) fp->f_data)->so_pgid;
189             return (0);
190         }
191         error = (*fp->f_ops->fo_ioctl)
192             (fp, (int) TIOCGPGRP, (caddr_t) retval, p);
193         *retval = -*retval;
194         return (error);
195     case F_SETOWN:
196         if (fp->f_type == DTYPE_SOCKET) {
197             ((struct socket *) fp->f_data)->so_pgid = uap->arg;
198             return (0);
199         }
200         if (uap->arg <= 0) {
201             uap->arg = -uap->arg;
202         } else {
203             struct proc *p1 = pfind(uap->arg);
204             if (p1 == 0)
205                 return (ESRCH);
206             uap->arg = p1->p_pgrp->pg_id;
207         }
208         return ((*fp->f_ops->fo_ioctl)
209             (fp, (int) TIOCSGPRP, (caddr_t) & uap->arg, p));
                                                                    kern_descrip.c

```

Figure 17.18 fcntl system call: socket processing.

168-185 `F_GETFL` returns the current file status flags associated with the descriptor and `F_SETFL` sets the flags. The new settings for `FNONBLOCK` and `FASYNC` are passed to the associated socket by calling `fo_ioctl`, which for sockets is the `soo_ioctl` function described with Figure 17.20. The third call to `fo_ioctl` is made only if the second call fails. It clears the `FNONBLOCK` flag, but should instead restore the flag to its original setting.

186-209 `F_GETOWN` returns `so_pgid`, the process or process group associated with the socket. For a descriptor other than a socket, the `TIOCGPGRP` `ioctl` command is passed to the associated `fo_ioctl` function. `F_SETOWN` assigns a new value to `so_pgid`.

For a descriptor other than a socket, the process group is checked in this function, but for sockets, the value is checked just before a signal is sent in `sohasoutofband` and in `sowakeup`.

### `ioctl` Code

We skip the `ioctl` system call itself and start with `soo_ioctl` in Figure 17.20, since most of the code in `ioctl` duplicates the code we described with Figure 17.17. We've already shown that this function sends routing commands to `rtioctl`, interface commands to `ifioctl`, and any remaining commands to the `pr_usrreq` function of the underlying protocol.

55-68 A few commands are handled by `soo_ioctl` directly. `FIONBIO` turns on non-blocking semantics if `*data` is nonzero, and turns them off otherwise. As we have seen, this flag affects the `accept`, `connect`, and `close` system calls as well as the various read and write system calls.

69-79 `FIOASYNC` enables or disables asynchronous I/O notification. Whenever there is activity on a socket, `sowakeup` gets called and if `SS_ASYNC` is set, the `SIGIO` signal is sent to the process or process group.

80-88 `FIONREAD` returns the number of bytes available in the receive buffer. `SIOCSPGRP` sets the process group associated with the socket, and `SIOCGPGRP` gets it. `so_pgid` is used as a target for the `SIGIO` signal as we just described and for the `SIGURG` signal when out-of-band data arrives for a socket. The signal is sent when the protocol layer calls the `sohasoutofband` function.

89-92 `SIOCATMARK` returns true if the socket is at the out-of-band synchronization mark, false otherwise.

`ioctl` commands, the `FIOxxx` and `SIOxxx` constants, have an internal structure illustrated in Figure 17.19.

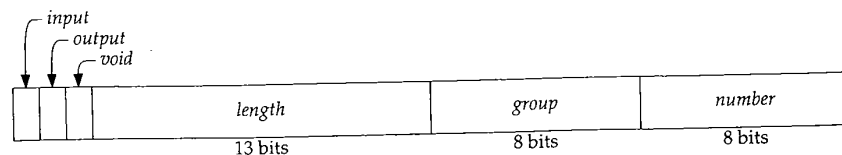

Figure 17.19 The structure of an `ioctl` command.

```

55 soo_ioctl(fp, cmd, data, p)
56 struct file *fp;
57 int cmd;
58 caddr_t data;
59 struct proc *p;
60 {
61     struct socket *so = (struct socket *) fp->f_data;
62     switch (cmd) {
63     case FIONBIO:
64         if (*(int *) data)
65             so->so_state |= SS_NBIO;
66         else
67             so->so_state &= ~SS_NBIO;
68         return (0);
69     case FIOASYNC:
70         if (*(int *) data) {
71             so->so_state |= SS_ASYNC;
72             so->so_rcv.sb_flags |= SB_ASYNC;
73             so->so_snd.sb_flags |= SB_ASYNC;
74         } else {
75             so->so_state &= ~SS_ASYNC;
76             so->so_rcv.sb_flags &= ~SB_ASYNC;
77             so->so_snd.sb_flags &= ~SB_ASYNC;
78         }
79         return (0);
80     case FIONREAD:
81         *(int *) data = so->so_rcv.sb_cc;
82         return (0);
83     case SIOCSPGRP:
84         so->so_pgid = *(int *) data;
85         return (0);
86     case SIOCGPGRP:
87         *(int *) data = so->so_pgid;
88         return (0);
89     case SIOCATMARK:
90         *(int *) data = (so->so_state & SS_RCVATMARK) != 0;
91         return (0);
92     }
93     /*
94     * Interface/routing/protocol specific ioctls:
95     * interface and routing ioctls should have a
96     * different entry since a socket's unnecessary
97     */
98     if (IOCGROUP(cmd) == 'i')
99         return (ifioctl(so, cmd, data, p));
100    if (IOCGROUP(cmd) == 'r')
101        return (rtioctl(cmd, data, p));
102    return ((*so->so_proto->pr_usrreq) (so, PRU_CONTROL,
103        (struct mbuf *) cmd, (struct mbuf *) data, (struct mbuf *) 0));
104 }

```

Figure 17.20 soo\_ioctl function.

If the third argument to `ioctl` is used as input, *input* is set. If the argument is used as output, *output* is set. If the argument is unused, *void* is set. *length* is the size of the argument in bytes. Related commands are in the same *group* but each command has its own *number* within the group. The macros in Figure 17.21 extract the components of an `ioctl` command.

Macro	Description
<code>IOCPARM_LEN(cmd)</code>	the <i>length</i> from <i>cmd</i>
<code>IOCBASECMD(cmd)</code>	the command with <i>length</i> set to 0
<code>IOCGROUP(cmd)</code>	the <i>group</i> from <i>cmd</i>

Figure 17.21 `ioctl` command macros.

93-104 The macro `IOCGROUP` extracts the 8-bit *group* from the command. Interface commands are handled by `ifioctl`. Routing commands are processed by `rtioctl`. All other commands are passed to the socket's protocol through the `PRU_CONTROL` request.

As we describe in Chapter 19, Net/2 introduced a new interface to the routing tables in which messages are passed to the routing subsystem through a socket created in the `PF_ROUTE` domain. This method replaces the `ioctl` method shown here. `rtioctl` always returns `ENOTSUPP` in kernels that do not have compatibility code compiled in.

## 17.6 `getsockname` System Call

The prototype for this system call is:

```
int getsockname(int fd, caddr_t asa, int *alen);
```

`getsockname` retrieves the local address bound to the socket *fd* and places it in the buffer pointed to by *asa*. This is useful when the kernel has selected an address during an implicit bind or when the process specified a wildcard address (Section 22.5) during an explicit call to `bind`. The `getsockname` system call is shown in Figure 17.22.

682-715 `getsock` locates the file structure for the descriptor. The size of the buffer specified by the process is copied from the process into *len*. This is the first call to `m_getclr` that we've seen—it allocates a standard mbuf and clears it with `bzero`. The protocol processing layer is responsible for returning the local address in *m* when the `PRU_SOCKADDR` request is issued.

If the address is larger than the buffer specified by the process, it is silently truncated when it is copied out to the process. *\*alen* is updated to the number of bytes copied out to the process. Finally, the mbuf is released and `getsockname` returns.

## 17.7 `getpeername` System Call

The prototype for this system call is:

```
int getpeername(int fd, caddr_t asa, int *alen);
```

```

682 struct getsockname_args {
683     int     fdes;
684     caddr_t asa;
685     int     *alen;
686 };

687 getsockname(p, uap, retval)
688 struct proc *p;
689 struct getsockname_args *uap;
690 int     *retval;
691 {
692     struct file *fp;
693     struct socket *so;
694     struct mbuf *m;
695     int     len, error;

696     if (error = getsock(p->p_fd, uap->fdes, &fp))
697         return (error);
698     if (error = copyin((caddr_t) uap->alen, (caddr_t) & len, sizeof(len)))
699         return (error);
700     so = (struct socket *) fp->f_data;
701     m = m_getclr(M_WAIT, MT_SONAME);
702     if (m == NULL)
703         return (ENOBUFS);
704     if (error = (*so->so_proto->pr_usrreq) (so, PRU_SOCKADDR, 0, m, 0))
705         goto bad;
706     if (len > m->m_len)
707         len = m->m_len;
708     error = copyout(mtod(m, caddr_t), (caddr_t) uap->asa, (u_int) len);
709     if (error == 0)
710         error = copyout((caddr_t) & len, (caddr_t) uap->alen,
711             sizeof(len));
712 bad:
713     m_freem(m);
714     return (error);
715 }

```

Figure 17.22 getsockname system call.

The `getpeername` system call returns the address of the remote end of the connection associated with the specified socket. This function is often called when a server is invoked through a `fork` and `exec` by the process that calls `accept` (i.e., any server started by `inetd`). The server doesn't have access to the peer address returned by `accept` and must use `getpeername`. The returned address is often checked against an access list for the application, and the connection is closed if the address is not on the list.

Some protocols, such as TP4, utilize this function to determine if an incoming connection should be rejected or confirmed. In TP4, the connection associated with a socket returned by `accept` is not yet complete and must be confirmed before the connection completes. Based on the address returned by `getpeername`, the server can close the connection or implicitly confirm the connection by sending or receiving data. This

feature is irrelevant for TCP, since TCP doesn't make a connection available to accept until the three-way handshake is complete. Figure 17.23 shows the `getpeername` function.

```

719 struct getpeername_args {
720     int     fdes;
721     caddr_t asa;
722     int     *alen;
723 };
724 getpeername(p, uap, retval)
725 struct proc *p;
726 struct getpeername_args *uap;
727 int     *retval;
728 {
729     struct file *fp;
730     struct socket *so;
731     struct mbuf *m;
732     int     len, error;
733     if (error = getsock(p->p_fd, uap->fdes, &fp))
734         return (error);
735     so = (struct socket *) fp->f_data;
736     if ((so->so_state & (SS_ISCONNECTED | SS_ISCONFIRMING)) == 0)
737         return (ENOTCONN);
738     if (error = copyin((caddr_t) uap->alen, (caddr_t) & len, sizeof(len)))
739         return (error);
740     m = m_getclr(M_WAIT, MT_SONAME);
741     if (m == NULL)
742         return (ENOBUFS);
743     if (error = (*so->so_proto->pr_usrreq) (so, PRU_PEERADDR, 0, m, 0))
744         goto bad;
745     if (len > m->m_len)
746         len = m->m_len;
747     if (error = copyout(mtod(m, caddr_t), (caddr_t) uap->asa, (u_int) len))
748         goto bad;
749     error = copyout((caddr_t) & len, (caddr_t) uap->alen, sizeof(len));
750 bad:
751     m_freem(m);
752     return (error);
753 }

```

*uipc\_syscalls.c*

*uipc\_syscalls.c*

Figure 17.23 `getpeername` system call.

719-753 The code here is almost identical to the `getsockname` code. `getsock` locates the socket and `ENOTCONN` is returned if the socket is not yet connected to a peer or if the connection is not in a confirmation state (e.g., TP4). If it is connected, the size of the buffer is copied in from the process and an mbuf is allocated to hold the address. The `PRU_PEERADDR` request is issued to get the remote address from the protocol layer. The address and the length of the address are copied from the kernel mbuf to the buffer in the process. The mbuf is released and the function returns.



## 17.8 Summary

In this chapter we discussed the six functions that modify the semantics of a socket. Socket options are processed by `setsockopt` and `getsockopt`. Additional options, some of which are not unique to sockets, are handled by `fcntl` and `ioctl`. Finally, connection information is available through `getsockname` and `getpeername`.

### Exercises

- 17.1 Why do you think options are limited to the size of a standard mbuf (MHLEN, 128 bytes)?
- 17.2 Why does the code at the end of Figure 17.7 work for the `SO_LINGER` option?
- 17.3 There is a problem with the suggested code used to test the `timeval` structure in Figure 17.9 since `tv->tv_sec * hz` may cause an overflow. Suggest a change to the code to solve this problem.

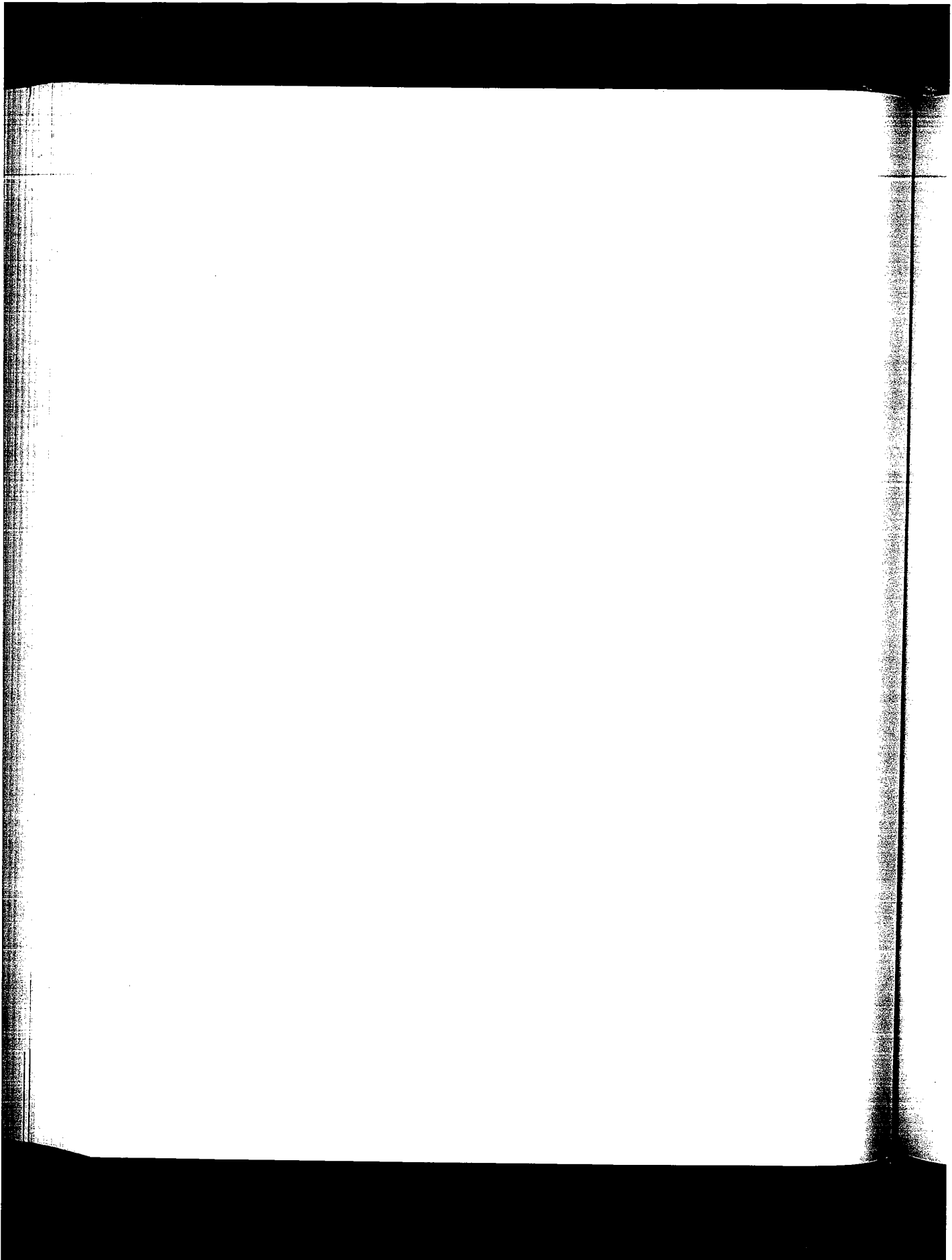

## Radix Tree Routing Tables

### 18.1 Introduction

The routing performed by IP, when it searches the routing table and decides which interface to send a packet out on, is a *routing mechanism*. This differs from a *routing policy*, which is a set of rules that decides which routes go into the routing table. The Net/3 kernel implements the routing mechanism while a routing daemon, typically *routed* or *gated*, implements the routing policy. The structure of the routing table must recognize that the packet forwarding occurs frequently—hundreds or thousands of times a second on a busy system—while routing policy changes are less frequent.

Routing is a detailed issue and we divide our discussion into three chapters.

- This chapter looks at the structure of the radix tree routing tables used by the Net/3 packet forwarding code. The tables are consulted by IP every time a packet is sent (since IP must determine which local interface receives the packet) and every time a packet is forwarded.
- Chapter 19 looks at the functions that interface between the kernel and the radix tree functions, and also at the routing messages that are exchanged between the kernel and routing processes—normally the routing daemons that implement the routing policy. These messages allow a process to modify the kernel's routing table (add a route, delete a route, etc.) and let the kernel notify the daemons when an asynchronous event occurs that might affect the routing policy (a redirect is received, an interface goes down, and so on).
- Chapter 20 presents the routing sockets that are used to exchange routing messages between the kernel and a process.

## 18.2 Routing Table Structure

Before looking at the internal structure of the Net/3 routing table, we need to understand the type of information contained in the table. Figure 18.1 is the bottom half of Figure 1.17: the four systems on the author's Ethernet.

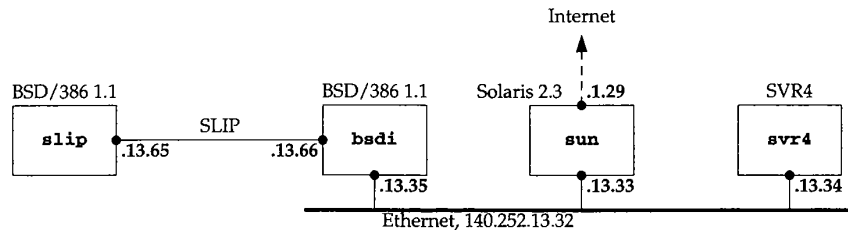

Figure 18.1 Subnet used for routing table example.

Figure 18.2 shows the routing table for bsdi in Figure 18.1.

```
bsdi $ netstat -rn
Routing tables

Internet:
Destination      Gateway          Flags    Refs    Use  Interface
default          140.252.13.33   UG S     0        3  le0
127              127.0.0.1       UG S R   0        2  lo0
127.0.0.1       127.0.0.1       U H      1       55  lo0
128.32.33.5     140.252.13.33   UGHS    2       16  le0
140.252.13.32   link#1          U C      0        0  le0
140.252.13.33   8:0:20:3:f6:42  U H L    11     55146  le0
140.252.13.34   0:0:c0:c2:9b:26 U H L    0        3  le0
140.252.13.35   0:0:c0:6f:2d:40 U H L    1       12  lo0
140.252.13.65   140.252.13.66  U H      0       41  sl0
224             link#1          U C      0        0  le0
224.0.0.1       link#1          U H L    0        5  le0
```

Figure 18.2 Routing table on the host bsdi.

We have modified the "Flags" column from the normal netstat output, making it easier to see which flags are set for the various entries.

The routes in this table were entered as follows. Steps 1, 3, 5, 8, and 9 are performed at system initialization when the /etc/netstart shell script is executed.

1. A default route is added by the route command to the host sun (140.252.13.33), which contains a PPP link to the Internet.
2. The entry for network 127 is typically created by a routing daemon such as gated, or it can be entered with the route command in the /etc/netstart file. This entry causes all packets sent to this network, other than references to the host 127.0.0.1 (which are covered by the more specific route entered in the next step), to be rejected by the loopback driver (Figure 5.27).

under-  
half of

4

3. The entry for the loopback interface (127.0.0.1) is configured by `ifconfig`.
4. The entry for `vangogh.cs.berkeley.edu` (128.32.33.5) was created by hand using the `route` command. It specifies the same router as the default route (140.252.13.33), but having a host-specific route, instead of using the default route for this host, allows routing metrics to be stored in this entry. These metrics can optionally be set by the administrator, are used by TCP each time a connection is established to the destination host, and are updated by TCP when the connection is closed. We describe these metrics in more detail with Figure 27.3.
5. The interface `le0` is initialized using the `ifconfig` command. This causes the entry for network 140.252.13.32 to be entered into the routing table.
6. The entries for the other two hosts on the Ethernet, `sun` (140.252.13.33) and `svr4` (140.252.13.34), were created by ARP, as we describe in Chapter 21. These are temporary entries that are removed if they are not used for a certain period of time.
7. The entry for the local host, 140.252.13.35, is created the first time the host's own IP address is referenced. The interface is the loopback, meaning any IP datagrams sent to the host's own IP address are looped back internally. The automatic creation of this entry is new with 4.4BSD, as we describe in Section 21.13.
8. The entry for the host 140.252.13.65 is created when the SLIP interface is configured by `ifconfig`.
9. The `route` command adds the route to network 224 through the Ethernet interface.
10. The entry for the multicast group 224.0.0.1 (the all-hosts group) was created by running the Ping program, pinging the address 224.0.0.1. This is also a temporary entry that is removed if not used for a certain period of time.

The "Flags" column in Figure 18.2 needs a brief explanation. Figure 18.25 provides a list of all the possible flags.

g it eas-

rformed

st sun

such as

tstart

ences to

d in the

- U The route is up.
- G The route is to a gateway (router). This is called an *indirect route*. If this flag is not set, the destination is directly connected; this is called a *direct route*.
- H The route is to a host, that is, the destination is a complete host address. If this flag is *not* set, the route is to a network, and the destination is a network address: a network ID, or a combination of a network ID and a subnet ID. The `netstat` command doesn't show it, but each network route also contains a network mask. A host route has an implied mask of all one bits.
- S The route is static. The three entries created by the `route` command in Figure 18.2 are static.

- C The route is cloned to create new routes. Two entries in this routing table have this flag set: (1) the route for the local Ethernet (140.252.13.32), which is cloned by ARP to create the host-specific routes of other hosts on the Ethernet, and (2) the route for multicast groups (224), which is cloned to create specific multicast group routes such as 224.0.0.1
- L The route contains a link-layer address. The host routes that ARP clones from the Ethernet network routes all have the link flag set. This applies to unicast and multicast addresses.
- R The loopback driver (the normal interface for routes with this flag) rejects all datagrams that use this route.

The ability to enter a route with the "reject" flag was provided in Net/2. It provides a simple way of preventing datagrams destined to network 127 from appearing outside the host. See also Exercise 6.6.

Before 4.3BSD Reno, two distinct routing tables were maintained by the kernel for IP addresses: one for host routes and one for network routes. A given route was entered into one table or the other, based on the type of route. The default route was stored in the network routing table with a destination address of 0.0.0.0. There was an implied hierarchy: a search was made for a host route first, and if not found a search was made for a network route, and if still not found, a search was made for a default route. Only if all three searches failed was the destination unreachable. Section 11.5 of [Leffler et al. 1989] describes the hash table with linked lists used for the host and network routing tables in Net/1.

Major changes took place in the internal representation of the routing table with 4.3BSD Reno [Sklower 1991]. These changes allow the same routing table functions to access a routing table for other protocol suites, notably the OSI protocols, which use variable-length addresses, unlike the fixed-length 32-bit Internet addresses. The internal structure was also changed, to provide faster lookups.

The Net/3 routing table uses a Patricia tree structure [Sedgewick 1990] to represent both host addresses and network addresses. (Patricia stands for "Practical Algorithm to Retrieve Information Coded in Alphanumeric.") The address being searched for and the addresses in the tree are considered as sequences of bits. This allows the same functions to maintain and search one tree containing fixed-length 32-bit Internet addresses, another tree containing fixed-length 48-bit XNS addresses, and another tree containing variable-length OSI addresses.

The idea of using Patricia trees for the routing table is attributed to Van Jacobson in [Sklower 1991]. These are actually binary radix tries with one-way branching removed.

An example is the easiest way to describe the algorithm. The goal of routing lookup is to find the most specific address that matches the given destination: the search key. The term *most specific* implies that a host address is preferred over a network address, which is preferred over a default address.

Each entry has an associated network mask, although no mask is stored with a host route; instead host routes have an implied mask of all one bits. An entry in the routing table matches a search key if the search key logically ANDed with the network mask of

the entry equals the entry itself. A given search key might match multiple entries in the routing table, so with a single table for both network route and host routes, the table must be organized so that more-specific routes are considered before less-specific routes.

Consider the examples in Figure 18.3. The two search keys are 127.0.0.1 and 127.0.0.2, which we show in hexadecimal since the logical ANDing is easier to illustrate. The two routing table entries are the host entry for 127.0.0.1 (with an implied mask of 0xffffffffff) and the network entry for 127.0.0.0 (with a mask of 0xff000000).

		search key = 127.0.0.1		search key = 127.0.0.2	
		host route	net route	host route	net route
1	search key	7f000001	7f000001	7f000002	7f000002
2	routing table key	7f000001	7f000000	7f000001	7f000000
3	routing table mask	fffffff	f000000	fffffff	f000000
4	logical AND of 1 and 3	7f000001	7f000000	7f000002	7f000000
2 and 4 equal?		yes	yes	no	yes

Figure 18.3 Example routing table lookups for the two search keys 127.0.0.1 and 127.0.0.2.

Since the search key 127.0.0.1 matches both routing table entries, the routing table must be organized so that the more-specific entry (127.0.0.1) is tried first.

Figure 18.4 shows the internal representation of the Net/3 routing table corresponding to Figure 18.2. This table was built from the output of the netstat command with the -A flag, which dumps the tree structure of the routing tables.

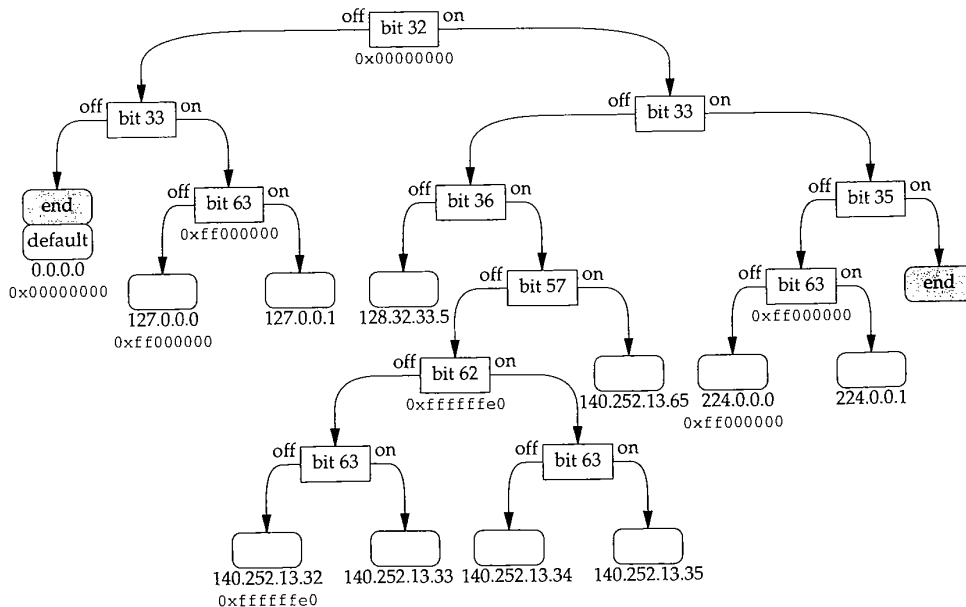

Figure 18.4 Net/3 routing table corresponding to Figure 18.2.

The two shaded boxes labeled “end” are leaves with special flags denoting the end of the tree. The left one has a key of all zero bits and the right one has a key of all one bits. The two boxes stacked together at the left, labeled “end” and “default,” are a special representation used for duplicate keys, which we describe in Section 18.9.

The square-cornered boxes are called *internal nodes* or just *nodes*, and the boxes with rounded corners are called *leaves*. Each internal node corresponds to a bit to test in the search key, and a branch is made to the left or the right. Each leaf corresponds to either a host address or a network address. If there is a hexadecimal number beneath a leaf, that leaf is a network address and the number specifies the network mask for the leaf. The absence of a hexadecimal mask beneath a leaf node implies that the leaf is a host address with an implied mask of `0xffffffff`.

Some of the internal nodes also contain network masks, and we’ll see how these are used in backtracking. Not shown in this figure is that every node also contains a pointer to its parent, to facilitate backtracking, deletion, and nonrecursive walks of the tree.

The bit comparisons are performed on socket address structures, so the bit positions given in Figure 18.4 are from the start of the socket address structure. Figure 18.5 shows the bit positions for a `sockaddr_in` structure.

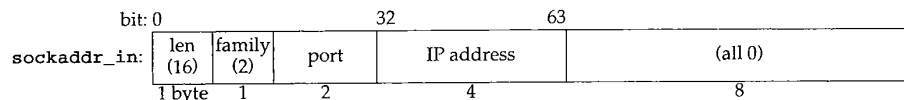

Figure 18.5 Bit offsets in Internet socket address structure.

The highest-order bit of the IP address is at bit position 32 and the lowest-order bit is at bit position 63. We also show the length as 16 and the address family as 2 (`AF_INET`), as we’ll encounter these two values throughout our examples.

To work through the examples we also need to show the bit representations of the various IP addresses in the tree. These are shown in Figure 18.6 along with some other IP addresses that are used in the examples that follow. The bit positions used in Figure 18.4 as branching points are shown in a bolder font.

We now provide some specific examples of how the routing table searches are performed.

### Example—Host Match

Assume the host address 127.0.0.1 is the search key—the destination address being looked up. Bit 32 is off, so the left branch is made from the top of the tree. Bit 33 is on, so the right branch is made from the next node. Bit 63 is on, so the right branch is made from the next node. This next node is a leaf, so the search key (127.0.0.1) is compared to the address in the leaf (127.0.0.1). They match exactly so this routing table entry is returned by the lookup function.



	32-bit IP address (bits 32-63)								dotted-decimal
bit:	3333	3333	4444	4444	4455	5555	5555	6666	
	2345	6789	0123	4567	8901	2345	6789	0123	
	0000	1010	0000	0001	0000	0010	0000	0011	10.1.2.3
	0111	0000	0000	0000	0000	0000	0000	0001	112.0.0.1
	0111	1111	0000	0000	0000	0000	0000	0000	127.0.0.0
	0111	1111	0000	0000	0000	0000	0000	0001	127.0.0.1
	0111	1111	0000	0000	0000	0000	0000	0011	127.0.0.3
	1000	0000	0010	0000	0010	0001	0000	0101	128.32.33.5
	1000	0000	0010	0000	0010	0001	0000	0110	128.32.33.6
	1000	1100	1111	1100	0000	1101	0010	0000	140.252.13.32
	1000	1100	1111	1100	0000	1101	0010	0001	140.252.13.33
	1000	1100	1111	1100	0000	1101	0010	0010	140.252.13.34
	1000	1100	1111	1100	0000	1101	0010	0011	140.252.13.35
	1000	1100	1111	1100	0000	1101	0100	0001	140.252.13.65
	1110	0000	0000	0000	0000	0000	0000	0000	224.0.0.0
	1110	0000	0000	0000	0000	0000	0000	0001	224.0.0.1

Figure 18.6 Bit representations of the IP addresses in Figures 18.2 and 18.4.

#### Example—Host Match

Next assume the search key is the address 140.252.13.35. Bit 32 is on, so the right branch is made from the top of the tree. Bit 33 is off, bit 36 is on, bit 57 is off, bit 62 is on, and bit 63 is on, so the search ends at the leaf on the bottom labeled 140.252.13.35. The search key matches the routing table key exactly.

#### Example—Network Match

The search key is 127.0.0.2. Bit 32 is off, bit 33 is on, and bit 63 is off so the search ends up at the leaf labeled 127.0.0.0. The search key and the routing table key don't match exactly, so a network match is tried. The search key is logically ANDed with the network mask (0xff000000) and since the result equals the routing table key, this entry is considered a match.

#### Example—Default Match

The search key is 10.1.2.3. Bit 32 is off and bit 33 is off, so the search ends up at the leaf with the duplicate keys labeled "end" and "default." The routing table key that is duplicated in these two leaves is 0.0.0.0. The search key and the routing table key don't match exactly, so a network match is tried. This match is tried for all duplicate keys that have a network mask. The first key (the end marker) doesn't have a network mask, so it is skipped. The next key (the default entry) has a mask of 0x00000000. The search key is logically ANDed with this mask and since the result equals the routing table key (0), this entry is considered a match. The default route is used.

**Example—Network Match with Backtracking**

The search key is 127.0.0.3. Bit 32 is off, bit 33 is on, and bit 63 is on, so the search ends up at the leaf labeled 127.0.0.1. The search key and the routing table key don't match exactly. A network match cannot be attempted since this leaf does not have a network mask. Backtracking now takes place.

The backtracking algorithm is to move up the tree, one level at a time. If an internal node is encountered that contains a mask, the search key is logically ANDed with the mask and another search is made of the subtree starting at the node with the mask, looking for a match with the ANDed key. If a match isn't found, the backtrack keeps moving up the tree, until the top is reached.

In this example the search moves up one level to the node for bit 63 and this node contains a mask. The search key is logically ANDed with the mask (0xff000000), giving a new search key of 127.0.0.0. Another search is made starting at this node for 127.0.0.0. Bit 63 is off, so the left branch is taken to the leaf labeled 127.0.0.0. The new search key is compared to the routing table key and since they're equal, this leaf is the match.

**Example—Backtracking Multiple Levels**

The search key is 112.0.0.1. Bit 32 is off, bit 33 is on, and bit 63 is on, so the search ends up at the leaf labeled 127.0.0.1. The keys are not equal and the routing table entry does not have a network mask, so backtracking takes place.

The search moves up one level to the node for bit 63, which contains a mask. The search key is logically ANDed with the mask of 0xff000000 and another search is made starting at that node. Bit 63 is off in the new search key, so the left branch is made to the leaf labeled 127.0.0.0. A comparison is made but the ANDed search key (112.0.0.0) doesn't equal the search key in the table.

Backtracking continues up one level from the bit-63 node to the bit-33 node. But this node does not have a mask, so the backtracking continues upward. The next level is the top of the tree (bit 32) and it has a mask. The search key (112.0.0.1) is logically ANDed with the mask (0x00000000) and a new search started from that point. Bit 32 is off in the new search key, as is bit 33, so the search ends up at the leaf labeled "end" and "default." The list of duplicate keys is traversed and the default key matches the new search key, so the default route is used.

As we can see in this example, if a default route is present in the routing table, when the backtrack ends up at the top node in the tree, its mask is all zero bits, which causes the search to proceed to the leftmost leaf in the tree for a match with the default.

**Example—Host Match with Backtracking and Cloning**

The search key is 224.0.0.5. Bit 32 is on, bit 33 is on, bit 35 is off, and bit 63 is on, so the search ends up at the leaf labeled 224.0.0.1. This routing table key does not equal the search key, and the routing table entry does not contain a network mask, so backtracking takes place.

The backtrack moves one level up to the node that tests bit 63. This node contains the mask `0xff000000`, so the search key ANDed with the mask yields a new search key of `224.0.0.0`. Another search is made, starting at this node. Since bit 63 is off in the ANDed key, the left branch is taken to the leaf labeled `224.0.0.0`. This routing table key matches the ANDed search key, so this entry is a match.

This route has the "clone" flag set (Figure 18.2), so a new leaf is created for the address `224.0.0.5`. The new routing table entry is

Destination	Gateway	Flags	Refs	Use	Interface
224.0.0.5	link#1	UHL	0	0	le0

and Figure 18.7 shows the new arrangement of the right side of the routing table tree from Figure 18.4, starting with the node for bit 35. Notice that whenever a new leaf is added to the tree, two nodes are needed: one for the leaf and one for the internal node specifying the bit to test.

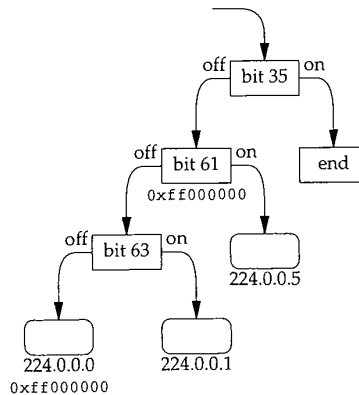

Figure 18.7 Modification of Figure 18.4 after inserting entry for `224.0.0.5`.

This newly created entry is the one returned to the caller who was searching for `224.0.0.5`.

### The Big Picture

Figure 18.8 shows a bigger picture of all the data structures involved. The bottom portion of this figure is from Figure 3.32.

There are numerous points about this figure that we'll note now and describe in detail later in this chapter.

- `rt_tables` is an array of pointers to `radix_node_head` structures. There is one entry in the array for each address family. `rt_tables[AF_INET]` points to the top of the Internet routing table tree.

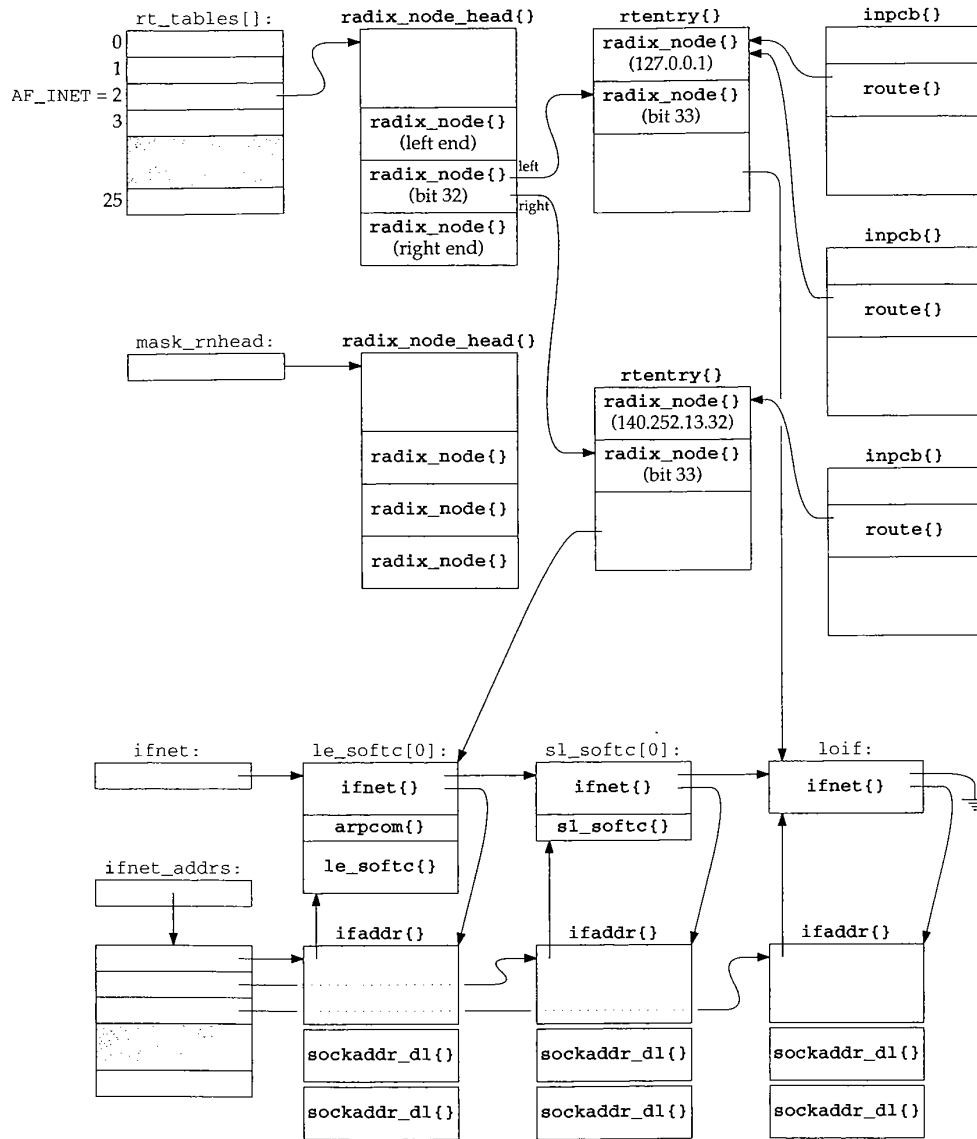

Figure 18.8 Data structures involved with routing tables.

- The `radix_node_head` structure contains three `radix_node` structures. These structures are built when the tree is initialized and the middle of the three is the top of the tree. This corresponds to the top box in Figure 18.4, labeled “bit 32.” The first of the three `radix_node` structures is the leftmost leaf in Figure 18.4 (the shared duplicate with the default route) and the third of the three is the rightmost leaf. An empty routing table consists of just these three `radix_node` structures; we’ll see how it is constructed by the `rn_inithead` function.
- The global `mask_rnhead` also points to a `radix_node_head` structure. This is the head of a separate tree of all the masks. Notice in Figure 18.4 that of the eight masks shown, one is duplicated four times and two are duplicated once. By keeping a separate tree for the masks, only one copy of each unique mask is maintained.
- The routing table tree is built from `rtentry` structures, and we show two of these in Figure 18.8. Each `rtentry` structure contains two `radix_node` structures, because each time a new entry is inserted into the tree, two nodes are required: an internal node corresponding to a bit to be tested, and a leaf node corresponding to a host route or a network route. In each `rtentry` structure we also show which bit test the internal node corresponds to and the address contained in the leaf node.

The remainder of the `rtentry` structure is the focal point of information for this route. We show only a single pointer from this structure to the corresponding `ifnet` structure for the route, but this structure also contains a pointer to the `ifaddr` structure, the flags for the route, a pointer to another `rtentry` structure if this entry is an indirect route, the metrics for the route, and so on.

- Protocol control blocks (Chapter 22), of which one exists for each UDP and TCP socket (Figure 22.1), contain a `route` structure that points to an `rtentry` structure. The UDP and TCP output functions both pass a pointer to the `route` structure in a PCB as the third argument to `ip_output`, each time an IP datagram is sent. PCBs that use the same route point to the same routing table entry.

## 18.3 Routing Sockets

When the routing table changes were made with 4.3BSD Reno, the interaction of processes with the routing subsystem also changed—the concept of routing sockets was introduced. Prior to 4.3BSD Reno, fixed-length `ioctl`s were issued by a process (such as the `route` command) to modify the routing table. 4.3BSD Reno changed this to a more generalized message-passing scheme using the new `PF_ROUTE` domain. A process creates a raw socket in the `PF_ROUTE` domain and can send routing messages to the kernel, and receives routing messages from the kernel (e.g., redirects and other asynchronous notifications from the kernel).

Figure 18.9 shows the 12 different types of routing messages. The message type is the `rtm_type` field in the `rt_msghdr` structure, which we describe in Figure 19.16. Only five of the messages can be issued by a process (a write to a routing socket), but all 12 can be received by a process.

We’ll defer our discussion of these routing messages until Chapter 19.

rtm_type	To kernel?	From kernel?	Description	Structure type
<i>RTM_ADD</i>	•	•	add route	rt_msghdr
<i>RTM_CHANGE</i>	•	•	change gateway, metrics, or flags	rt_msghdr
<i>RTM_DELADDR</i>	•	•	address being removed from interface	ifa_msghdr
<i>RTM_DELETE</i>	•	•	delete route	rt_msghdr
<i>RTM_GET</i>	•	•	report metrics and other route information	rt_msghdr
<i>RTM_IFINFO</i>	•	•	interface going up, down, etc.	if_msghdr
<i>RTM_LOCK</i>	•	•	lock specified metrics	rt_msghdr
<i>RTM_LOSING</i>	•	•	kernel suspects route is failing	rt_msghdr
<i>RTM_MISS</i>	•	•	lookup failed on this address	rt_msghdr
<i>RTM_NEWADDR</i>	•	•	address being added to interface	ifa_msghdr
<i>RTM_REDIRECT</i>	•	•	kernel told to use different route	rt_msghdr
<i>RTM_RESOLVE</i>	•	•	request to resolve destination to link-layer address	rt_msghdr

Figure 18.9 Types of messages exchanged across a routing socket.

## 18.4 Code Introduction

Three headers and five C files define the various structures and functions used for routing. These are summarized in Figure 18.10.

File	Description
net/radix.h	radix node definitions
net/raw_cb.h	routing control block definitions
net/route.h	routing structures
net/radix.c	radix node (Patricia tree) functions
net/raw_cb.c	routing control block functions
net/raw_usrreq.c	routing control block functions
net/route.c	routing functions
net/rsock.c	routing socket functions

Figure 18.10 Files discussed in this chapter.

In general, the prefix *rn\_* denotes the radix node functions that search and manipulate the Patricia trees, the *raw\_* prefix denotes the routing control block functions, and the three prefixes *route\_*, *rt\_*, and *rt* denote the general routing functions.

We use the term *routing control blocks* instead of *raw control blocks* in all the routing chapters, even though the files and functions begin with the prefix *raw*. This is to avoid confusion with the raw IP control blocks and functions, which we discuss in Chapter 32. Although the raw control blocks and their associated functions are used for more than just routing sockets in Net/3 (one of the raw OSI protocols uses these structures and functions), our use in this text is only with routing sockets in the PF\_ROUTE domain.

Figure 18.11 shows the primary routing functions and their relationships. The shaded ellipses are the ones we cover in this chapter and the next two. We also show where each of the 12 routing message types are generated.

ure  
?  
hdr  
hdr  
ghdr  
hdr  
hdr  
hdr  
hdr  
hdr  
ghdr  
hdr  
hdr

out-

ipulate  
nd the

hapters,  
ion with  
the raw  
ockets in  
is text is

s. The  
o show

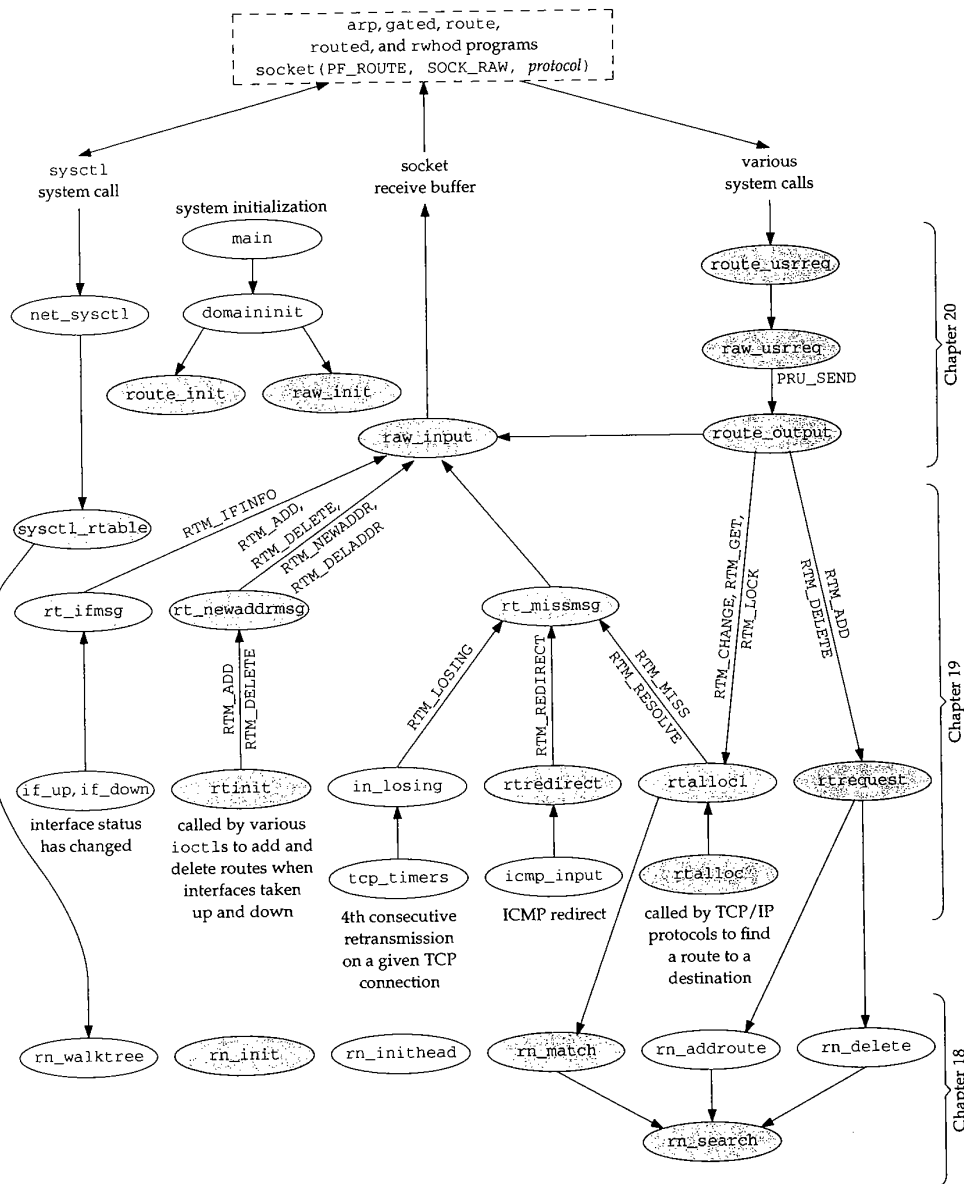

Figure 18.11 Relationships between the various routing functions.

`rtalloc` is the function called by the Internet protocols to look up routes to destinations. We've already encountered `rtalloc` in the `ip_rtaddr`, `ip_forward`, `ip_output`, and `ip_setmoptions` functions. We'll also encounter it later in the `in_pcbconnect` and `tcp_mss` functions.

We also show in Figure 18.11 that five programs typically create sockets in the routing domain:

- `arp` manipulates the ARP cache, which is stored in the IP routing table in Net/3 (Chapter 21),
- `gated` and `routed` are routing daemons that communicate with other routers and manipulate the kernel's routing table as the routing environment changes (routers and links go up or down),
- `route` is a program typically executed by start-up scripts or by the system administrator to add or delete routes, and
- `rwhod` issues a routing `sysctl` on start-up to determine the attached interfaces.

Naturally, any process (with superuser privilege) can open a routing socket to send and receive messages to and from the routing subsystem; we show only the common system programs in Figure 18.11.

### Global Variables

The global variables introduced in the three routing chapters are shown in Figure 18.12.

Variable	Datatype	Description
<code>rt_tables</code>	<code>struct radix_node_head * []</code>	array of pointers to heads of routing tables
<code>mask_rnhead</code>	<code>struct radix_node_head *</code>	pointer to head of mask table
<code>rn_mkfreelist</code>	<code>struct radix_mask *</code>	head of linked list of available <code>radix_mask</code> structures
<code>max_keylen</code>	<code>int</code>	longest routing table key, in bytes
<code>rn_zeros</code>	<code>char *</code>	array of all zero bits, of length <code>max_keylen</code>
<code>rn_ones</code>	<code>char *</code>	array of all one bits, of length <code>max_keylen</code>
<code>maskedKey</code>	<code>char *</code>	array for masked search key, of length <code>max_keylen</code>
<code>rtstat</code>	<code>struct rtstat</code>	routing statistics (Figure 18.13)
<code>rttrash</code>	<code>int</code>	#routes not in table but not freed
<code>rawcb</code>	<code>struct rawcb</code>	head of doubly linked list of routing control blocks
<code>raw_recvspace</code>	<code>u_long</code>	default size of routing socket receive buffer, 8192 bytes
<code>raw_sendspace</code>	<code>u_long</code>	default size of routing socket send buffer, 8192 bytes
<code>route_cb</code>	<code>struct route_cb</code>	#routing socket listeners, per protocol, and total
<code>route_dst</code>	<code>struct sockaddr</code>	temporary for destination of routing message
<code>route_src</code>	<code>struct sockaddr</code>	temporary for source of routing message
<code>route_proto</code>	<code>struct sockproto</code>	temporary for protocol of routing message

Figure 18.12 Global variables in the three routing chapters.



## Statistics

Some routing statistics are maintained in the global structure `rtstat`, described in Figure 18.13.

rtstat member	Description	Used by SNMP
<code>rts_badredirect</code>	#invalid redirect calls	
<code>rts_dynamic</code>	#routes created by redirects	
<code>rts_newgateway</code>	#routes modified by redirects	
<code>rts_unreach</code>	#lookups that failed	
<code>rts_wildcard</code>	#lookups matched by wildcard (never used)	

Figure 18.13 Routing statistics maintained in the `rtstat` structure.

We'll see where these counters are incremented as we proceed through the code. None are used by SNMP.

Figure 18.14 shows some sample output of these statistics from the `netstat -rs` command, which displays this structure.

netstat -rs output	rtstat member
1029 bad routing redirects	<code>rts_badredirect</code>
0 dynamically created routes	<code>rts_dynamic</code>
0 new gateways due to redirects	<code>rts_newgateway</code>
0 destinations found unreachable	<code>rts_unreach</code>
0 uses of a wildcard route	<code>rts_wildcard</code>

Figure 18.14 Sample routing statistics.

## SNMP Variables

Figure 18.15 shows the IP routing table, named `ipRouteTable`, and the kernel variables that supply the corresponding value.

For `ipRouteType`, if the `RTF_GATEWAY` flag is set in `rt_flags`, the route is remote (4); otherwise the route is direct (3). For `ipRouteProto`, if either the `RTF_DYNAMIC` or `RTF_MODIFIED` flag is set, the route was created or modified by ICMP (4), otherwise the value is other (1). Finally, if the `rt_mask` pointer is null, the returned mask is all one bits (i.e., a host route).

## 18.5 Radix Node Data Structures

In Figure 18.8 we see that the head of each routing table is a `radix_node_head` and all the nodes in the routing tree, both the internal nodes and the leaves, are `radix_node` structures. The `radix_node_head` structure is shown in Figure 18.16.

IP routing table, index = <ipRouteDest>		
SNMP variable	Variable	Description
ipRouteDest	rt_key	Destination IP address. A value of 0.0.0.0 indicates a default entry.
ipRouteIfIndex	rt_ifp.if_index	Interface number: ifIndex.
ipRouteMetric1	-1	Primary routing metric. The meaning of the metric depends on the routing protocol (ipRouteProto). A value of -1 means it is not used.
ipRouteMetric2	-1	Alternative routing metric.
ipRouteMetric3	-1	Alternative routing metric.
ipRouteMetric4	-1	Alternative routing metric.
ipRouteNextHop	rt_gateway	IP address of next-hop router.
ipRouteType	(see text)	Route type: 1 = other, 2 = invalidated route, 3 = direct, 4 = indirect.
ipRouteProto	(see text)	Routing protocol: 1 = other, 4 = ICMP redirect, 8 = RIP, 13 = OSPF, 14 = BGP, and others.
ipRouteAge	(not implemented)	Number of seconds since route was last updated or determined to be correct.
ipRouteMask	rt_mask	Mask to be logically ANDed with destination IP address before being compared with ipRouteDest.
ipRouteMetric5	-1	Alternative routing metric.
ipRouteInfo	NULL	Reference to MIB definitions specific to this particular routing protocol.

Figure 18.15 IP routing table: ipRouteTable.

```

91 struct radix_node_head (
92     struct radix_node *rnh_treetop;
93     int     rnh_addrsize;      /* (not currently used) */
94     int     rnh_pktsize;      /* (not currently used) */
95     struct radix_node *(*rnh_addaddr) /* add based on sockaddr */
96     (void *v, void *mask,
97     struct radix_node_head * head, struct radix_node nodes[]);
98     struct radix_node *(*rnh_addpkt) /* add based on packet hdr */
99     (void *v, void *mask,
100    struct radix_node_head * head, struct radix_node nodes[]);
101    struct radix_node *(*rnh_deladdr) /* remove based on sockaddr */
102    (void *v, void *mask, struct radix_node_head * head);
103    struct radix_node *(*rnh_delpkt) /* remove based on packet hdr */
104    (void *v, void *mask, struct radix_node_head * head);
105    struct radix_node *(*rnh_matchaddr) /* locate based on sockaddr */
106    (void *v, struct radix_node_head * head);
107    struct radix_node *(*rnh_matchpkt) /* locate based on packet hdr */
108    (void *v, struct radix_node_head * head);
109    int     (*rnh_walktree) /* traverse tree */
110    (struct radix_node_head * head, int (*f) (), void *w);
111    struct radix_node rnh_nodes[3]; /* top and end nodes */
112 };

```

Figure 18.16 radix\_node\_head structure: the top of each routing tree.

92 `rnh_treetop` points to the top `radix_node` structure for the routing tree. Notice that three of these structures are allocated at the end of the `radix_node_head`, and the middle one of these is initialized as the top of the tree (Figure 18.8).

93-94 `rnh_addrsize` and `rnh_pktsize` are not currently used.

`rnh_addrsize` is to facilitate porting the routing table code to systems that don't have a length byte in the socket address structure. `rnh_pktsize` is to allow using the radix node machinery to examine addresses in packet headers without having to copy the address into a socket address structure.

95-110 The seven function pointers, `rnh_addaddr` through `rnh_walktree`, point to functions that are called to operate on the tree. Only four of these pointers are initialized by `rn_inithead` and the other three are never used by Net/3, as shown in Figure 18.17.

Member	Initialized to (by <code>rn_inithead</code> )
<code>rnh_addaddr</code>	<code>rn_addroute</code>
<code>rnh_addpkt</code>	<code>NULL</code>
<code>rnh_deladdr</code>	<code>rn_delete</code>
<code>rnh_delpkt</code>	<code>NULL</code>
<code>rnh_matchaddr</code>	<code>rn_match</code>
<code>rnh_matchpkt</code>	<code>NULL</code>
<code>rnh_walktree</code>	<code>rn_walktree</code>

Figure 18.17 The seven function pointers in the `radix_node_head` structure.

111-112 Figure 18.18 shows the `radix_node` structure that forms the nodes of the tree. In Figure 18.8 we see that three of these are allocated in the `radix_node_head` and two are allocated in each `rtentry` structure.

```

-----radix.h
40 struct radix_node {
41     struct radix_mask *rn_mklist; /* list of masks contained in subtree */
42     struct radix_node *rn_p; /* parent pointer */
43     short rn_b; /* bit offset; -1-index(netmask) */
44     char rn_bmask; /* node: mask for bit test */
45     u_char rn_flags; /* Figure 18.20 */
46     union {
47         struct { /* leaf only data: rn_b < 0 */
48             caddr_t rn_Key; /* object of search */
49             caddr_t rn_Mask; /* netmask, if present */
50             struct radix_node *rn_Dupedkey;
51         } rn_leaf;
52         struct { /* node only data: rn_b >= 0 */
53             int rn_Off; /* where to start compare */
54             struct radix_node *rn_L; /* left pointer */
55             struct radix_node *rn_R; /* right pointer */
56         } rn_node;
57     } rn_u;
58 };

59 #define rn_dupedkey rn_u.rn_leaf.rn_Dupedkey
60 #define rn_key rn_u.rn_leaf.rn_Key

```

```

61 #define rn_mask      rn_u.rn_leaf.rn_Mask
62 #define rn_off       rn_u.rn_node.rn_Off
63 #define rn_l         rn_u.rn_node.rn_L
64 #define rn_r         rn_u.rn_node.rn_R

```

*radix.h*

Figure 18.18 radix\_node structure: the nodes of the routing tree.

41-45 The first five members are common to both internal nodes and leaves, followed by a union defining three members if the node is a leaf, or a different three members if the node is internal. As is common throughout the Net/3 code, a set of #define statements provide shorthand names for the members in the union.

41-42 rn\_mklist is the head of a linked list of masks for this node. We describe this field in Section 18.9. rn\_p points to the parent node.

43 If rn\_b is greater than or equal to 0, the node is an internal node, else the node is a leaf. For the internal nodes, rn\_b is the bit number to test: for example, its value is 32 in the top node of the tree in Figure 18.4. For leaves, rn\_b is negative and its value is -1 minus the *index of the network mask*. This index is the first bit number where a 0 occurs. Figure 18.19 shows the indexes of the masks from Figure 18.4.

	32-bit IP mask (bits 32-63)								index	rn_b
	3333	3333	4444	4444	4455	5555	5555	6666		
	2345	6789	0123	4567	8901	2345	6789	0123		
00000000:	0000	0000	0000	0000	0000	0000	0000	0000	0	-1
ff000000:	1111	1111	0000	0000	0000	0000	0000	0000	40	-41
ffffffe0:	1111	1111	1111	1111	1111	1111	1110	0000	59	-60

Figure 18.19 Example of mask indexes.

As we can see, the index of the all-zero mask is handled specially: its index is 0, not 32.

44 rn\_bmask is a 1-byte mask used with the internal nodes to test whether the corresponding bit is on or off. Its value is 0 in leaves. We'll see how this member is used with the rn\_off member shortly.

45 Figure 18.20 shows the three values for the rn\_flags member.

Constant	Description
RNF_ACTIVE	this node is alive (for rtfree)
RNF_NORMAL	leaf contains normal route (not currently used)
RNF_ROOT	node is in the radix_node_head structure

Figure 18.20 rn\_flags values.

The RNF\_ROOT flag is set only for the three radix nodes in the radix\_node\_head structure: the top of the tree and the left and right end nodes. These three nodes can never be deleted from the routing tree.

48-49 For a leaf, `rn_key` points to the socket address structure and `rn_mask` points to a socket address structure containing the mask. If `rn_mask` is null, the implied mask is all one bits (i.e., this route is to a host, not to a network).

Figure 18.21 shows an example corresponding to the leaf for 140.252.13.32 in Figure 18.4.

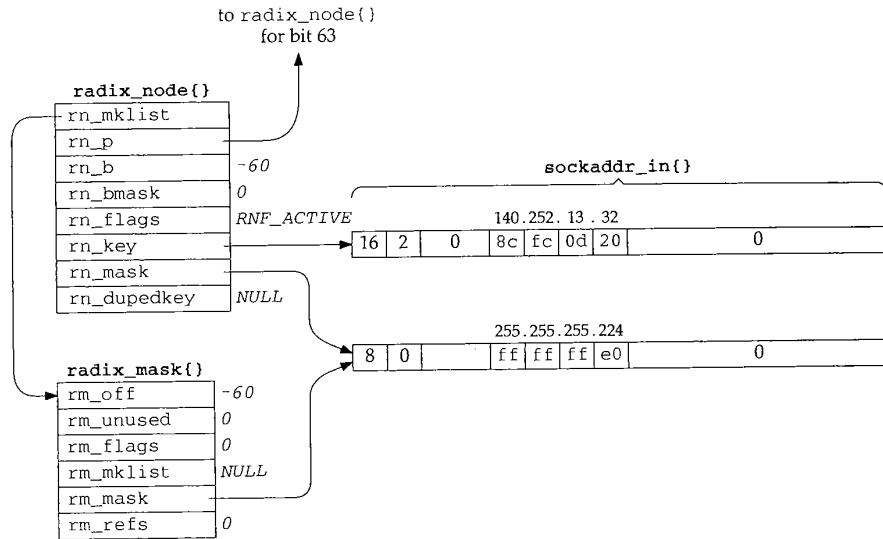

Figure 18.21 radix\_node structure corresponding to leaf for 140.252.13.32 in Figure 18.4.

This example also shows a `radix_mask` structure, which we describe in Figure 18.22. We draw this latter structure with a smaller width, to help distinguish it as a different structure from the `radix_node`; we'll encounter both structures in many of the figures that follow. We describe the reason for the `radix_mask` structure in Section 18.9.

The `rn_b` of -60 corresponds to an index of 59. `rn_key` points to a `sockaddr_in`, with a length of 16 and an address family of 2 (`AF_INET`). The mask structure pointed to by `rn_mask` and `rm_mask` has a length of 8 and a family of 0 (this family is `AF_UNSPEC`, but it is never even looked at).

50-51 The `rn_dupedkey` pointer is used when there are multiple leaves with the same key. We describe these in Section 18.9.

52-58 We describe `rn_off` in Section 18.8. `rn_l` and `rn_r` are the left and right pointers for the internal node.

Figure 18.22 shows the `radix_mask` structure.

dix.h

by a f the tate-

field

e is a is 32 is -1 curs.

: 32. corre-used

\_head es can

```

-----radix.h
76 extern struct radix_mask {
77     short   rm_b;           /* bit offset; -1-index(netmask) */
78     char    rm_unused;     /* cf. rn_bmask */
79     u_char  rm_flags;      /* cf. rn_flags */
80     struct radix_mask *rm_mklist; /* more masks to try */
81     caddr_t rm_mask;       /* the mask */
82     int     rm_refs;       /* # of references to this struct */
83 }
-----radix.h

```

Figure 18.22 radix\_mask structure.

76-83 Each of these structures contains a pointer to a mask: `rm_mask`, which is really a pointer to a socket address structure containing the mask. Each `radix_node` structure points to a linked list of `radix_mask` structures, allowing multiple masks per node: `rn_mklist` points to the first, and then each `rm_mklist` points to the next. This structure definition also declares the global `rn_mkfreelist`, which is the head of a linked list of available structures.

## 18.6 Routing Structures

The focal points of access to the kernel's routing information are

1. the `rtalloc` function, which searches for a route to a destination,
2. the `route` structure that is filled in by this function, and
3. the `rtentry` structure that is pointed to by the `route` structure.

Figure 18.8 showed that the protocol control blocks (PCBs) used by UDP and TCP (Chapter 22) contain a `route` structure, which we show in Figure 18.23.

```

-----route.h
46 struct route {
47     struct rtentry *ro_rt; /* pointer to struct with information */
48     struct sockaddr ro_dst; /* destination of this route */
49 };
-----route.h

```

Figure 18.23 route structure.

`ro_dst` is declared as a generic socket address structure, but for the Internet protocols it is a `sockaddr_in`. Notice that unlike most references to this type of structure, `ro_dst` is the structure itself, not a pointer to one.

At this point it is worth reviewing Figure 8.24, which shows the use of these routes every time an IP datagram is output.

- If the caller passes a pointer to a `route` structure, that structure is used. Otherwise a local `route` structure is used and it is set to 0, setting `ro_rt` to a null pointer. UDP and TCP pass a pointer to the `route` structure in their PCB to `ip_output`.

radix.h

radix.h

really a  
structure  
node:  
; struc-  
linked

- If the route structure points to an rtable structure (the ro\_rt pointer is nonnull), and if the referenced interface is still up, and if the destination address in the route structure equals the destination address of the IP datagram, that route is used. Otherwise the socket address structure ro\_dst is filled in with the destination IP address and rtable is called to locate a route to that destination. For a TCP connection the destination address of the datagram never changes from the destination address of the route, but a UDP application can send a datagram to a different destination with each sendto.
- If rtable returns a null pointer in ro\_rt, a route was not found and ip\_output returns an error.
- If the RTF\_GATEWAY flag is set in the rtable structure, the route is indirect (the G flag in Figure 18.2). The destination address (dst) for the interface output function becomes the IP address of the gateway, the rt\_gateway member, not the destination address of the IP datagram.

Figure 18.24 shows the rtable structure.

id TCP

-route.h

\*/

-route.h

protocols  
structure,

the routes

Other-  
to a null  
PCB to

```

83 struct rtable {
84     struct radix_node rt_nodes[2]; /* a leaf and an internal node */
85     struct sockaddr *rt_gateway; /* value associated with rn_key */
86     short rt_flags; /* Figure 18.25 */
87     short rt_refcnt; /* #held references */
88     u_long rt_use; /* raw #packets sent */
89     struct ifnet *rt_ifp; /* interface to use */
90     struct ifaddr *rt_ifa; /* interface address to use */
91     struct sockaddr *rt_genmask; /* for generation of cloned routes */
92     caddr_t rt_llinfo; /* pointer to link level info cache */
93     struct rt_metrics rt_rmx; /* metrics: Figure 18.26 */
94     struct rtable *rt_gwroute; /* implied entry for gatewayed routes */
95 };
96 #define rt_key(r) ((struct sockaddr *)((r)->rt_nodes->rn_key))
97 #define rt_mask(r) ((struct sockaddr *)((r)->rt_nodes->rn_mask))
    
```

Figure 18.24 rtable structure.

83-84 Two radix\_node structures are contained within this structure. As we noted in the example with Figure 18.7, each time a new leaf is added to the routing tree a new internal node is also added. rt\_nodes[0] contains the leaf entry and rt\_nodes[1] contains the internal node. The two #define statements at the end of Figure 18.24 provide a shorthand access to the key and mask of this leaf node.

86 Figure 18.25 shows the various constants stored in rt\_flags and the corresponding character output by netstat in the "Flags" column (Figure 18.2).

The RTF\_BLACKHOLE flag is not output by netstat and the two with lowercase flag characters, RTF\_DONE and RTF\_MASK, are used in routing messages and not normally stored in the routing table entry.

85 If the RTF\_GATEWAY flag is set, rt\_gateway contains a pointer to a socket address structure containing the address (e.g., the IP address) of that gateway. Also,

Constant	netstat flag	Description
<i>RTF_BLACKHOLE</i>		discard packets without error (loopback driver: Figure 5.27)
<i>RTF_CLONING</i>	C	generate new routes on use (used by ARP)
<i>RTF_DONE</i>	d	kernel confirmation that message from process was completed
<i>RTF_DYNAMIC</i>	D	created dynamically (by redirect)
<i>RTF_GATEWAY</i>	G	destination is a gateway (indirect route)
<i>RTF_HOST</i>	H	host entry (else network entry)
<i>RTF_LLIINFO</i>	L	set by ARP when <i>rt_llinfo</i> pointer valid
<i>RTF_MASK</i>	m	subnet mask present (not used)
<i>RTF_MODIFIED</i>	M	modified dynamically (by redirect)
<i>RTF_PROTO1</i>	1	protocol-specific routing flag
<i>RTF_PROTO2</i>	2	protocol-specific routing flag (ARP uses)
<i>RTF_REJECT</i>	R	discard packets with error (loopback driver: Figure 5.27)
<i>RTF_STATIC</i>	S	manually added entry ( <i>route</i> program)
<i>RTF_UP</i>	U	route usable
<i>RTF_XRESOLVE</i>	X	external daemon resolves name (used with X.25)

Figure 18.25 *rt\_flags* values.

*rt\_gwroute* points to the *rtable* for that gateway. This latter pointer was used in *ether\_output* (Figure 4.15).

87 *rt\_refcnt* counts the “held” references to this structure. We describe this counter at the end of Section 19.3. This counter is output as the “Refs” column in Figure 18.2.

88 *rt\_use* is initialized to 0 when the structure is allocated; we saw it incremented in Figure 8.24 each time an IP datagram was output using the route. This counter is also the value printed in the “Use” column in Figure 18.2.

89-90 *rt\_ifp* and *rt\_ifa* point to the interface structure and the interface address structure, respectively. Recall from Figure 6.5 that a given interface can have multiple addresses, so minimally the *rt\_ifa* is required.

92 The *rt\_llinfo* pointer allows link-layer protocols to store pointers to their protocol-specific structures in the routing table entry. This pointer is normally used with the *RTF\_LLIINFO* flag. Figure 21.1 shows how ARP uses this pointer.

```

----- route.h
54 struct rt_metrics {
55     u_long  rmx_locks;          /* bitmask for values kernel leaves alone */
56     u_long  rmx_mtu;           /* MTU for this path */
57     u_long  rmx_hopcount;      /* max hops expected */
58     u_long  rmx_expire;       /* lifetime for route, e.g. redirect */
59     u_long  rmx_recvpipe;     /* inbound delay-bandwidth product */
60     u_long  rmx_sendpipe;     /* outbound delay-bandwidth product */
61     u_long  rmx_ssthresh;     /* outbound gateway buffer limit */
62     u_long  rmx_rtt;          /* estimated round trip time */
63     u_long  rmx_rttvar;       /* estimated RTT variance */
64     u_long  rmx_pksent;       /* #packets sent using this route */
65 };
----- route.h

```

Figure 18.26 *rt\_metrics* structure.



93 Figure 18.26 shows the `rt_metrics` structure, which is contained within the  
`rtentry` structure. Figure 27.3 shows that TCP uses six members in this structure.  
54-65 `rmx_locks` is a bitmask telling the kernel which of the eight metrics that follow  
must not be modified. The values for this bitmask are shown in Figure 20.13.  
`rmx_expire` is used by ARP (Chapter 21) as a timer for each ARP entry. Contrary  
to the comment with `rmx_expire`, it is not used for redirects.

Figure 18.28 summarizes the structures that we've described, their relationships, and the various types of socket address structures they reference. The `rtentry` that we show is for the route to 128.32.33.5 in Figure 18.2. The other `radix_node` contained in the `rtentry` is for the bit 36 test right above this node in Figure 18.4. The two `sockaddr_dl` structures pointed to by the first `ifaddr` were shown in Figure 3.38. Also note from Figure 6.5 that the `ifnet` structure is contained within an `le_softc` structure, and the second `ifaddr` structure is contained within an `in_ifaddr` structure.

## 18.7 Initialization: `route_init` and `rtable_init` Functions

The initialization of the routing tables is somewhat obscure and takes us back to the domain structures in Chapter 7. Before outlining the function calls, Figure 18.27 shows the relevant fields from the domain structure (Figure 7.5) for various protocol families.

Member	OSI value	Internet value	Routing value	Unix value	XNS value	Comment
<code>dom_family</code>	<code>AF_ISO</code>	<code>AF_INET</code>	<code>PF_ROUTE</code>	<code>AF_UNIX</code>	<code>AF_NS</code>	
<code>dom_init</code>	0	0	<code>route_init</code>	0	0	
<code>dom_rtattach</code>	<code>rn_inithead</code>	<code>rn_inithead</code>	0	0	<code>rn_inithead</code>	
<code>dom_rtoffset</code>	48	32	0	0	16	in bits
<code>dom_maxrtkey</code>	32	16	0	0	16	in bytes

Figure 18.27 Members of domain structure relevant to routing.

The `PF_ROUTE` domain is the only one with an initialization function. Also, only the domains that require a routing table have a `dom_rtattach` function, and it is always `rn_inithead`. The routing domain and the Unix domain protocols do not require a routing table.

The `dom_rtoffset` member is the offset, in bits, (from the beginning of the domain's socket address structure) of the first bit to be examined for routing. The size of this structure in bytes is given by `dom_maxrtkey`. We saw earlier in this chapter that the offset of the IP address in the `sockaddr_in` structure is 32 bits. The `dom_maxrtkey` member is the size in bytes of the protocol's socket address structure: 16 for `sockaddr_in`.

Figure 18.29 outlines the steps involved in initializing the routing tables.

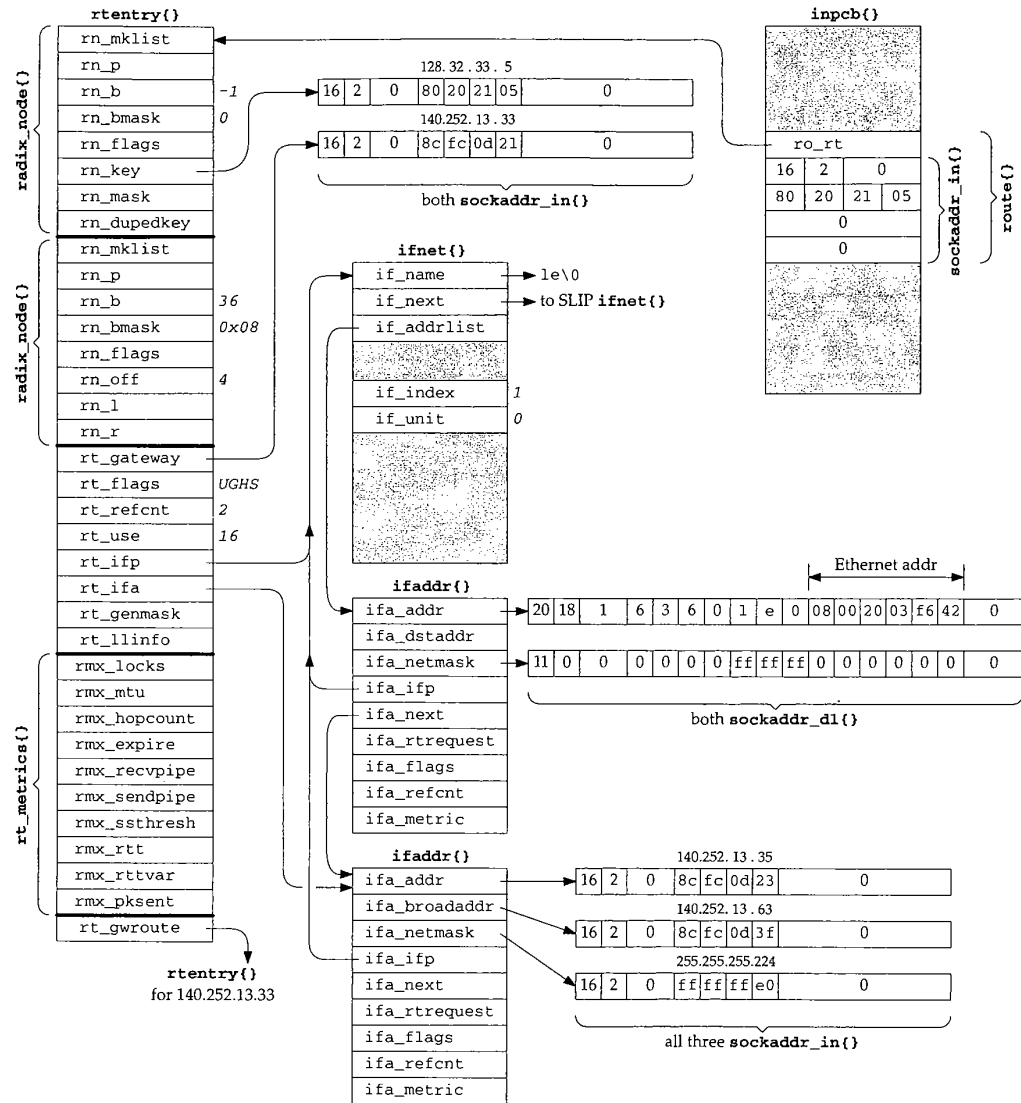

Figure 18.28 Summary of routing structures.

```

main()          /* kernel initialization */
{
    ...
    ifinit();
    domaininit();
    ...
}
domaininit()    /* Figure 7.15 */
{
    ...
    ADDDOMAIN(unix);
    ADDDOMAIN(route);
    ADDDOMAIN(inet);
    ADDDOMAIN(osi);
    ...
    for ( dp = all domains ) {
        (*dp->dom_init)();
        for ( pr = all protocols for this domain )
            (*pr->pr_init)();
    }
}
raw_init()     /* pr_init() function for SOCK_RAW/PF_ROUTE protocol */
{
    initialize head of routing protocol control blocks;
}
route_init()   /* dom_init() function for PF_ROUTE domain */
{
    rn_init();
    rtable_init();
}
rn_init()
{
    for ( dp = all domains )
        if (dp->dom_maxrtkey > max_keylen)
            max_keylen = dp->dom_maxrtkey;
    allocate and initialize rn_zeros, rn_ones, masked_key;
    rn_inithead(&mask_rnhead); /* allocate and init tree for masks */
}
rtable_init()
{
    for ( dp = all domains )
        (*dp->dom_rtattach)(&rt_tables[dp->dom_family]);
}
rn_inithead() /* dom_rtattach() function for all protocol families */
{
    allocate and initialize one radix_node_head structure;
}

```

Figure 18.29 Steps involved in initialization of routing tables.

`domaininit` is called once by the kernel's main function when the system is initialized. The linked list of domain structures is built by the `ADDDOMAIN` macro and the linked list is traversed, calling each domain's `dom_init` function, if defined. As we saw in Figure 18.27, the only `dom_init` function is `route_init`, which is shown in Figure 18.30.

```

49 void
50 route_init()
51 {
52     rn_init(); /* initialize all zeros, all ones, mask table */
53     rtable_init((void **) rt_tables);
54 }

```

route.c

Figure 18.30 `route_init` function.

The function `rn_init`, shown in Figure 18.32, is called only once.

The function `rtable_init`, shown in Figure 18.31, is also called only once. It in turn calls all the `dom_rtattach` functions, which initialize a routing table tree for that domain.

```

39 void
40 rtable_init(table)
41 void **table;
42 {
43     struct domain *dom;
44     for (dom = domains; dom; dom = dom->dom_next)
45         if (dom->dom_rtattach)
46             dom->dom_rtattach(&table[dom->dom_family],
47                               dom->dom_rtoffset);
48 }

```

route.c

Figure 18.31 `rtable_init` function: call each domain's `dom_rtattach` function.

We saw in Figure 18.27 that the only `dom_rtattach` function is `rn_inithead`, which we describe in the next section.

## 18.8 Initialization: `rn_init` and `rn_inithead` Functions

The function `rn_init`, shown in Figure 18.32, is called once by `route_init` to initialize some of the globals used by the radix functions.

```

750 void
751 rn_init()
752 {
753     char *cp, *cplim;
754     struct domain *dom;

```

radix.c

```

755     for (dom = domains; dom; dom = dom->dom_next)
756         if (dom->dom_maxrtkey > max_keylen)
757             max_keylen = dom->dom_maxrtkey;
758     if (max_keylen == 0) {
759         printf("rn_init: radix functions require max_keylen be set\n");
760         return;
761     }
762     R_Malloc(rn_zeros, char *, 3 * max_keylen);
763     if (rn_zeros == NULL)
764         panic("rn_init");
765     Bzero(rn_zeros, 3 * max_keylen);
766     rn_ones = cp = rn_zeros + max_keylen;
767     maskedKey = cplim = rn_ones + max_keylen;
768     while (cp < cplim)
769         *cp++ = -1;

770     if (rn_inithead((void **) &mask_rnhead, 0) == 0)
771         panic("rn_init 2");
772 }

```

radix.c

Figure 18.32 rn\_init function.

**Determine max\_keylen**

750-761 All the domain structures are examined and the global `max_keylen` is set to the largest value of `dom_maxrtkey`. In Figure 18.27 the largest value is 32 for `AF_ISO`, but in a typical system that excludes the OSI and XNS protocols, `max_keylen` is 16, the size of a `sockaddr_in` structure.

**Allocate and initialize rn\_zeros, rn\_ones, and maskedKey**

762-769 A buffer three times the size of `max_keylen` is allocated and the pointer stored in the global `rn_zeros`. `R_Malloc` is a macro that calls the kernel's `malloc` function, specifying a type of `M_RTABLE` and `M_DONTWAIT`. We'll also encounter the macros `Bcmp`, `Bcopy`, `Bzero`, and `Free`, which call kernel functions of similar names, with the arguments appropriately type cast.

This buffer is divided into three pieces, and each piece is initialized as shown in Figure 18.33.

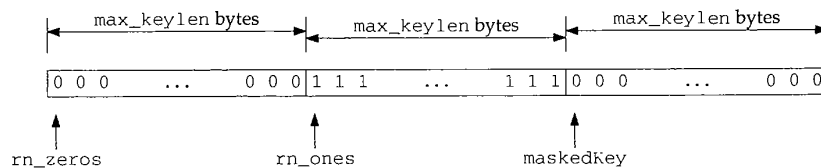

Figure 18.33 rn\_zeros, rn\_ones, and maskedKey arrays.

`rn_zeros` is an array of all zero bits, `rn_ones` is an array of all one bits, and `maskedKey` is an array used to hold a temporary copy of a search key that has been masked.

## Initialize tree of masks

770-772 The function `rn_inithead` is called to initialize the head of the routing tree for the address masks; the `radix_node_head` structure pointed to by the global `mask_rnhead` in Figure 18.8.

From Figure 18.27 we see that `rn_inithead` is also the `dom_attach` function for all the protocols that require a routing table. Instead of showing the source code for this function, Figure 18.34 shows the `radix_node_head` structure that it builds for the Internet protocols.

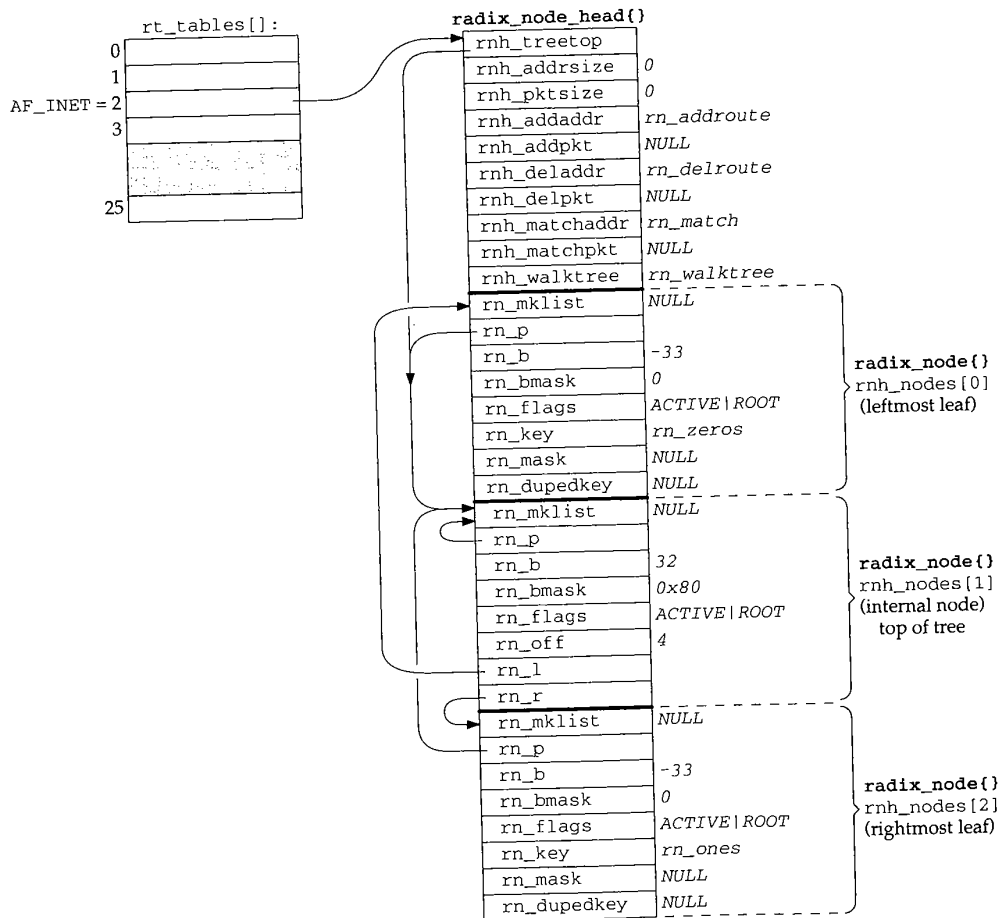

Figure 18.34 `radix_node_head` structure built by `rn_inithead` for Internet protocols.

The three `radix_node` structures form a tree: the middle of the three is the top (it is pointed to by `rnh_treetop`), the first of the three is the leftmost leaf of the tree, and

the last of the three is the rightmost leaf of the tree. The parent pointer of all three nodes (`rn_p`) points to the middle node.

The value 32 for `rn_h_nodes[1].rn_b` is the bit position to test. It is from the `dom_rtoffset` member of the Internet domain structure (Figure 18.27). Instead of performing shifts and masks during forwarding, the byte offset and corresponding byte mask are precomputed. The byte offset from the start of a socket address structure is in the `rn_off` member of the `radix_node` structure (4 in this case) and the byte mask is in the `rn_bmask` member (0x80 in this case). These values are computed whenever a `radix_node` structure is added to the tree, to speed up the comparisons during forwarding. As additional examples, the offset and byte mask for the two nodes that test bit 33 in Figure 18.4 would be 4 and 0x40, respectively. The offset and byte mask for the two nodes that test bit 63 would be 7 and 0x01.

The value of -33 for the `rn_b` member of both leaves is negative one minus the index of the leaf.

The key of the leftmost node is all zero bits (`rn_zeros`) and the key of the rightmost node is all one bits (`rn_ones`).

All three nodes have the `RNF_ROOT` flag set. (We have omitted the `RNF_` prefix.) This indicates that the node is one of the three original nodes used to build the tree. These are the only nodes with this flag.

One detail we have not mentioned is that the Network File System (NFS) also uses the routing table functions. For each mount point on the local host a `radix_node_head` structure is allocated, along with an array of pointers to these structures (indexed by the protocol family), similar to the `rt_tables` array. Each time this mount point is exported, the protocol address of the host that can mount this filesystem is added to the appropriate tree for the mount point.

## 18.9 Duplicate Keys and Mask Lists

Before looking at the source code that looks up entries in a routing table we need to understand two fields in the `radix_node` structure: `rn_dupedkey`, which forms a linked list of additional `radix_node` structures containing duplicate keys, and `rn_mklist`, which starts a linked list of `radix_mask` structures containing network masks.

We first return to Figure 18.4 and the two boxes on the far left of the tree labeled "end" and "default." These are duplicate keys. The leftmost node with the `RNF_ROOT` flag set (`rn_h_nodes[0]` in Figure 18.34) has a key of all zero bits, but this is the same key as the default route. We would have the same problem with the rightmost end node in the tree, which has a key of all one bits, if an entry were created for 255.255.255.255, but this is the limited broadcast address, which doesn't appear in the routing table. In general, the radix node functions in Net/3 allow any key to be duplicated, if each occurrence has a unique mask.

Figure 18.35 shows the two nodes with a duplicate key of all zero bits. In this figure we have removed the `RNF_` prefix for the `rn_flags` and omit nonnull parent, left, and right pointers, which add nothing to the discussion.

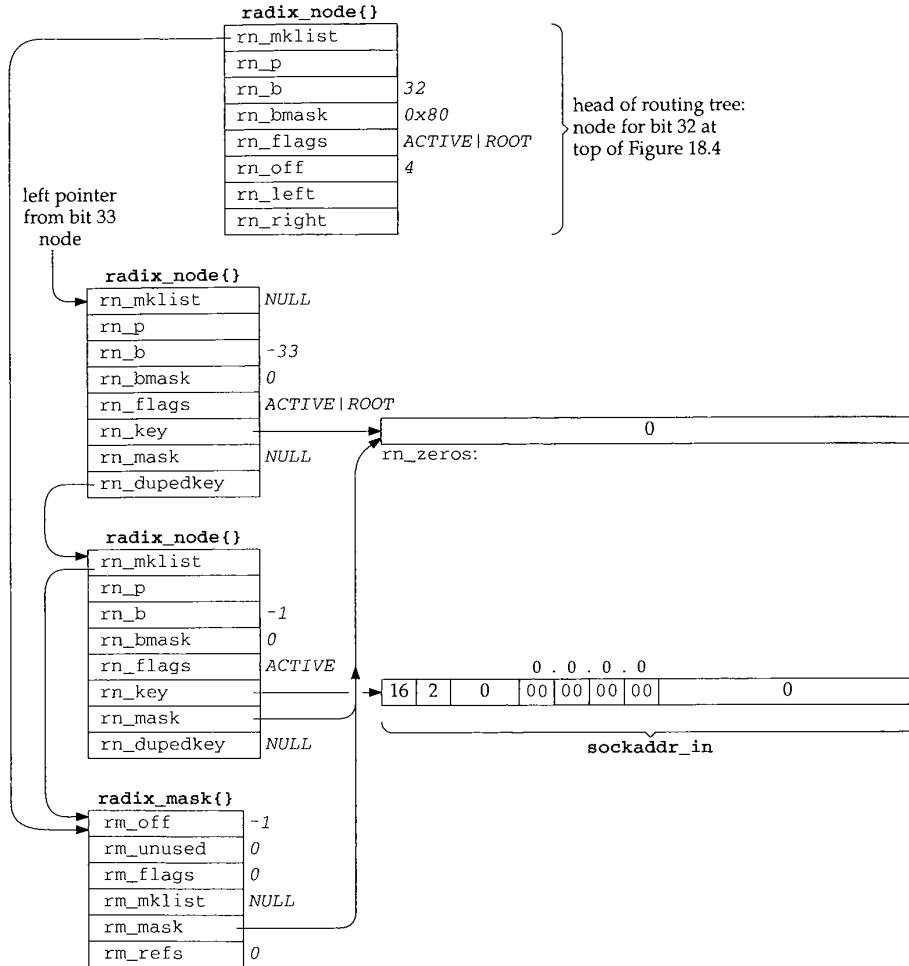

Figure 18.35 Duplicated nodes with a key of all zero bits.

The top node is the top of the routing tree—the node for bit 32 at the top of Figure 18.4. The next two nodes are leaves (their *rn\_b* values are negative) with the *rn\_dupedkey* member of the first pointing to the second. The first of these two leaves is the *rn\_h\_nodes*[0] structure from Figure 18.34, which is the left end marker of the tree—its *RNF\_ROOT* flag is set. Its key was explicitly set by *rn\_inithead* to *rn\_zeros*.

The second of these leaves is the entry for the default route. Its *rn\_key* points to *sockaddr\_in* with the value 0.0.0.0, and it has a mask of all zero bits. Its *rn\_mask* points to *rn\_zeros*, since equivalent masks in the mask table are shared.



Normally keys are not shared, let alone shared with masks. The `rn_key` pointers of the two end markers (those with the `RNF_ROOT` flag) are special since they are built by `rn_inithead` (Figure 18.34). The key of the left end marker points to `rn_zeros` and the key of the right end marker points to `rn_ones`.

The final structure is a `radix_mask` structure and is pointed to by both the top node of the tree and the leaf for the default route. The list from the top node of the tree is used with the backtracking algorithm when the search is looking for a network mask. The list of `radix_mask` structures with an internal node specifies the masks that apply to subtrees starting at that node. In the case of duplicate keys, a mask list also appears with the leaves, as we'll see in the following example.

We now show a duplicate key that is added to the routing tree intentionally and the resulting mask list. In Figure 18.4 we have a network route for 127.0.0.1 and a network route for 127.0.0.0. The default mask for the class A network route is `0xff000000`, as we show in the figure. If we divide the 24 bits following the class A network ID into a 16-bit subnet ID and an 8-bit host ID, we can add a route for the subnet 127.0.0 with a mask of `0xfffff00`:

```
bsd1 $ route add 127.0.0.0 -netmask 0xfffff00 140.252.13.33
```

Although it makes little practical sense to use network 127 in this fashion, our interest is in the resulting routing table structure. Although duplicate keys are not common with the Internet protocols (other than the previous example with the default route), duplicate keys are required to provide routes to subnet 0 of any network.

There is an implied priority in these three entries with a network ID of 127. If the search key is 127.0.0.1 it matches all three entries, but the host route is selected because it is the *most specific*: its mask (`0xffffffff`) has the most one bits. If the search key is 127.0.0.2 it matches both network routes, but the route for subnet 0, with a mask of `0xfffff00`, is more specific than the route with a mask of `0xff000000`. The search key 127.1.2.3 matches only the entry with a mask of `0xff000000`.

Figure 18.36 shows the resulting tree structure, starting at the internal node for bit 33 from Figure 18.4. We show two boxes for the entry with the key of 127.0.0.0 since there are two leaves with this duplicate key.

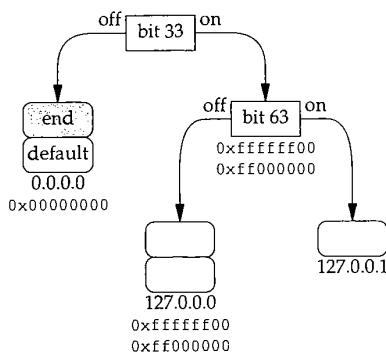

Figure 18.36 Routing tree showing duplicate keys for 127.0.0.0.

Figure 18.37 shows the resulting radix\_node and radix\_mask structures.

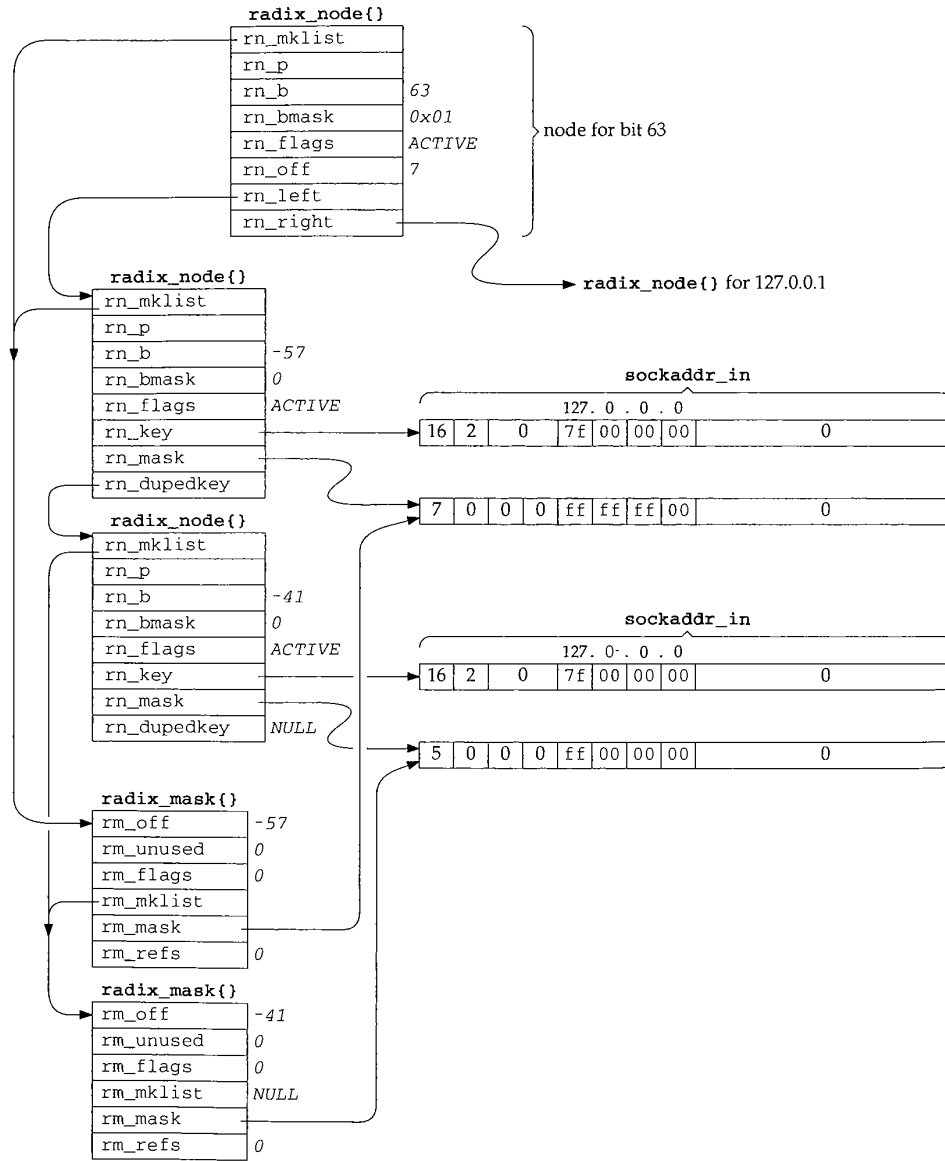

Figure 18.37 Example routing table structures for the duplicate keys for network 127.0.0.0.

First look at the linked list of `radix_mask` structures for each `radix_node`. The mask list for the top node (bit 63) consists of the entry for `0xffffffff00` followed by `0xff000000`. The more-specific mask comes first in the list so that it is tried first. The mask list for the second `radix_node` (the one with the `rn_b` of `-57`) is the same as that of the first. But the list for the third `radix_node` consists of only the entry with a mask of `0xff000000`.

Notice that masks with the same value are shared but keys with the same value are not. This is because the masks are maintained in their own routing tree, explicitly to be shared, because equal masks are so common (e.g., every class C network route has the same mask of `0xffffffff00`), while equal keys are infrequent.

## 18.10 rn\_match Function

We now show the `rn_match` function, which is called as the `rnh_matchaddr` function for the Internet protocols. We'll see that it is called by the `rtalloc1` function, which is called by the `rtalloc` function. The algorithm is as follows:

1. Start at the top of the tree and go to the leaf corresponding to the bits in the search key. Check the leaf for an exact match (Figure 18.38).
2. Check the leaf for a network match (Figure 18.40).
3. Backtrack (Figure 18.43).

Figure 18.38 shows the first part of `rn_match`.

```

135 struct radix_node *
136 rn_match(v_arg, head)
137 void *v_arg;
138 struct radix_node_head *head;
139 {
140     caddr_t v = v_arg;
141     struct radix_node *t = head->rnh_treetop, *x;
142     caddr_t cp = v, cp2, cp3;
143     caddr_t cplim, mstart;
144     struct radix_node *saved_t, *top = t;
145     int off = t->rn_off, vlen = *(u_char *) cp, matched_off;
146     /*
147      * Open code rn_search(v, top) to avoid overhead of extra
148      * subroutine call.
149      */
150     for (; t->rn_b >= 0;) {
151         if (t->rn_bmask & cp[t->rn_off])
152             t = t->rn_r; /* right if bit on */
153         else
154             t = t->rn_l; /* left if bit off */
155     }

```

*radix.c*

```

156  /*
157  * See if we match exactly as a host destination
158  */
159  cp += off;
160  cp2 = t->rn_key + off;
161  cplim = v + vlen;
162  for (; cp < cplim; cp++, cp2++)
163      if (*cp != *cp2)
164          goto on1;
165  /*
166  * This extra grot is in case we are explicitly asked
167  * to look up the default. Ugh!
168  */
169  if ((t->rn_flags & RNF_ROOT) && t->rn_dupedkey)
170      t = t->rn_dupedkey;
171  return t;
172  on1:

```

radix.c

Figure 18.38 rn\_match function: go down tree, check for exact host match.

135-145 The first argument `v_arg` is a pointer to a socket address structure, and the second argument `head` is a pointer to the `radix_node_head` structure for the protocol. All protocols call this function (Figure 18.17) but each calls it with a different `head` argument.

In the assignment statements, `off` is the `rn_off` member of the top node of the tree (4 for Internet addresses, from Figure 18.34), and `vlen` is the length field from the socket address structure of the search key (16 for Internet addresses).

#### Go down the tree to the corresponding leaf

146-155 This loop starts at the top of the tree and moves down the left and right branches until a leaf is encountered (`rn_b` is less than 0). Each test of the appropriate bit is made using the precomputed byte mask in `rn_bmask` and the corresponding precomputed offset in `rn_off`. For Internet addresses, `rn_off` will be 4, 5, 6, or 7.

#### Check for exact match

156-164 When the leaf is encountered, a check is first made for an exact match. All bytes of the socket address structure, starting at the `rn_off` value for the protocol family, are compared. This is shown in Figure 18.39 for an Internet socket address structure.

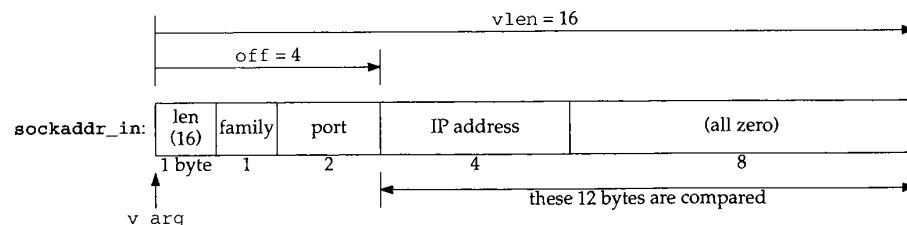
Figure 18.39 Variables during comparison of `sockaddr_in` structures.

As soon as a mismatch is found, a jump is made to `on1`.

Normally the final 8 bytes of the `sockaddr_in` are 0 but proxy ARP (Section 21.12) sets one of these bytes nonzero. This allows two routing table entries for a given IP address: one for the normal IP address (with the final 8 bytes of 0) and a proxy ARP entry for the same IP address (with one of the final 8 bytes nonzero).

The length byte in Figure 18.39 was assigned to `vlen` at the beginning of the function, and we'll see that `rtalloc1` uses the family member to select the routing table to search. The port is never used by the routing functions.

#### Explicit check for default

165-172 Figure 18.35 showed that the default route is stored as a duplicate leaf with a key of 0. The first of the duplicate leaves has the `RNF_ROOT` flag set. Hence if the `RNF_ROOT` flag is set in the matching node and the leaf contains a duplicate key, the value of the pointer `rn_dupedkey` is returned (i.e., the pointer to the node containing the default route in Figure 18.35). If a default route has not been entered and the search matches the left end marker (a key of all zero bits), or if the search encounters the right end marker (a key of all one bits), the returned pointer `t` points to a node with the `RNF_ROOT` flag set. We'll see that `rtalloc1` explicitly checks whether the matching node has this flag set, and considers such a match an error.

At this point in `rn_match` a leaf has been reached but it is not an exact match with the search key. The next part of the function, shown in Figure 18.40, checks whether the leaf is a network match.

```

173     matched_off = cp - v;
174     saved_t = t;
175     do {
176         if (t->rn_mask) {
177             /*
178              * Even if we don't match exactly as a host;
179              * we may match if the leaf we wound up at is
180              * a route to a net.
181              */
182             cp3 = matched_off + t->rn_mask;
183             cp2 = matched_off + t->rn_key;
184             for (; cp < cplim; cp++)
185                 if ((*cp2++ ^ *cp) & *cp3++)
186                     break;
187             if (cp == cplim)
188                 return t;
189             cp = matched_off + v;
190         }
191     } while (t = t->rn_dupedkey);
192     t = saved_t;

```

*radix.c*

*radix.c*

Figure 18.40 `rn_match` function: check for network match.

173-174 `cp` points to the unequal byte in the search key. `matched_off` is set to the offset of this byte from the start of the socket address structure.

175-183 The `do while` loop iterates through all duplicate leaves and each one with a network mask is compared. Let's work through the code with an example. Assume we're

looking up the IP address 140.252.13.60 in the routing table in Figure 18.4. The search will end up at the node labeled 140.252.13.32 (bits 62 and 63 are both off), which contains a network mask. Figure 18.41 shows the structures when the for loop in Figure 18.40 starts executing.

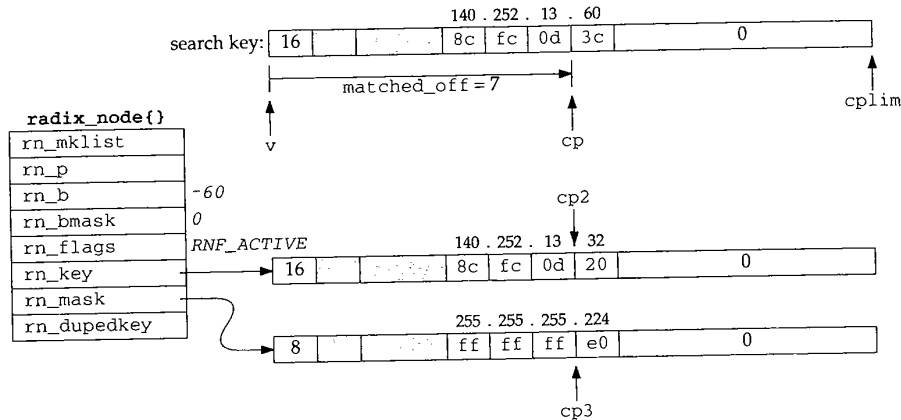

Figure 18.41 Example for network mask comparison.

The search key and the routing table key are both `sockaddr_in` structures, but the length of the mask is different. The mask length is the minimum number of bytes containing nonzero values. All the bytes past this point, up through `max_keylen`, are 0.

184-190 The search key is exclusive ORed with the routing table key, and the result logically ANDed with the network mask, one byte at a time. If the resulting byte is ever nonzero, the loop terminates because they don't match (Exercise 18.1). If the loop terminates normally, however, the search key ANDed with the network mask matches the routing table entry. The pointer to the routing table entry is returned.

Figure 18.42 shows how this example matches, and how the IP address 140.252.13.188 does not match, looking at just the fourth byte of the IP address. The search for both IP addresses ends up at this node since both addresses have bits 57, 62, and 63 off.

	search key = 140.252.13.60	search key = 140.252.13.188
search key byte (*cp):	0011 1100 = 3c	1011 1100 = bc
routing table key byte (*cp2):	0010 0000 = 20	0010 0000 = 20
exclusive OR:	0001 1100	1001 1100
network mask byte (*cp3):	1110 0000 = e0	1110 0000 = e0
logical AND:	0000 0000	1000 0000

Figure 18.42 Example of search key match using network mask.

The first example (140.252.13.60) matches since the result of the logical AND is 0 (and all the remaining bytes in the address, the key, and the mask are all 0). The other example does not match since the result of the logical AND is nonzero.

193

19.

19.

19

19.

search  
and con-  
n Fig-

plim

]

]

at the  
; con-  
: 0.  
ically  
zero,  
s nor-  
uting

dress  
The  
7, 62,

and all  
mple

191 If the routing table entry has duplicate keys, the loop is repeated for each key.

The final portion of `rn_match`, shown in Figure 18.43, backtracks up the tree, looking for a network match or a match with the default.

```

193     /* start searching up the tree */
194     do {
195         struct radix_mask *m;
196         t = t->rn_p;
197         if (m = t->rn_mklist) {
198             /*
199              * After doing measurements here, it may
200              * turn out to be faster to open code
201              * rn_search_m here instead of always
202              * copying and masking.
203              */
204             off = min(t->rn_off, matched_off);
205             mstart = maskedKey + off;
206             do {
207                 cp2 = mstart;
208                 cp3 = m->rm_mask + off;
209                 for (cp = v + off; cp < cplim;)
210                     *cp2++ = *cp++ & *cp3++;
211                 x = rn_search(maskedKey, t);
212                 while (x && x->rn_mask != m->rm_mask)
213                     x = x->rn_dupekey;
214                 if (x &&
215                     (Bcmp(mstart, x->rn_key + off,
216                         vlen - off) == 0))
217                     return x;
218             } while (m = m->rn_mklist);
219         }
220     } while (t != top);
221     return 0;
222 };

```

*radix.c*

Figure 18.43 `rn_match` function: backtrack up the tree.

193-195 The do while loop continues up the tree, checking each level, until the top has been checked.

196 The pointer `t` is replaced with the pointer to the parent node, moving up one level. Having the parent pointer in each node simplifies backtracking.

197-210 Each level is checked only if the internal node has a nonnull list of masks. `rn_mklist` is a pointer to a linked list of `radix_mask` structures, each containing a mask that applies to the subtree starting at that node. The inner do while loop iterates through each `radix_mask` structure on the list.

Using the previous example, 140.252.13.188, Figure 18.44 shows the various data structures when the innermost for loop starts. This loop logically ANDs each byte of the search key with each byte of the mask, storing the result in the global `maskedKey`. The mask value is `0xffffffe0` and the search would have backtracked from the leaf for 140.252.13.32 in Figure 18.4 two levels to the node that tests bit 62.

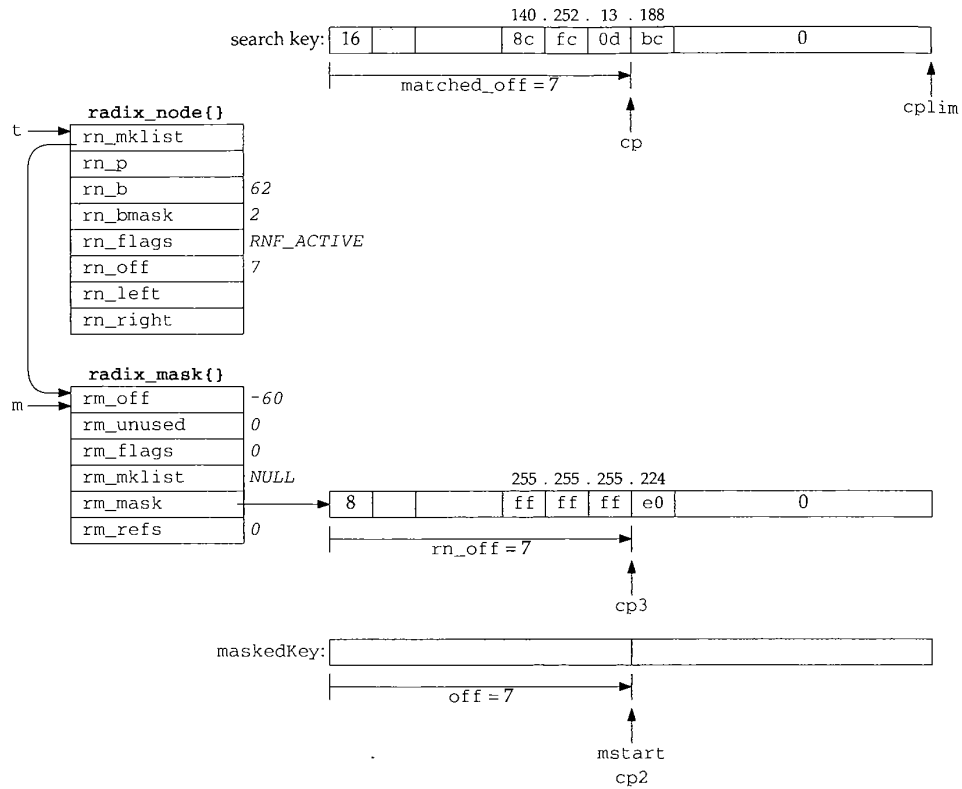

Figure 18.44 Preparation to search again using masked search key.

Once the for loop completes, the masking is complete, and `rn_search` (shown in Figure 18.48) is called with `maskedKey` as the search key and the pointer `t` as the top of the subtree to search. Figure 18.45 shows the value of `maskedKey` for our example.

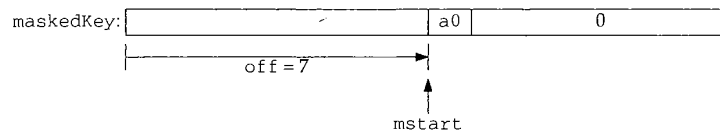

Figure 18.45 maskedKey when `rn_search` is called.

The byte `0xa0` is the logical AND of `0xbc` (188, the search key) and `0xe0` (the mask). `rn_search` proceeds down the tree from its starting point, branching right or left depending on the key, until a leaf is reached. In this example the search key is the 9 bytes shown in Figure 18.45 and the leaf that's reached is the one labeled `140.252.13.32` in Figure 18.4, since bits 62 and 63 are off in the byte `0xa0`. Figure 18.46 shows the data structures when `Bcmp` is called to check if a match has been found.

211



]
↑
plim

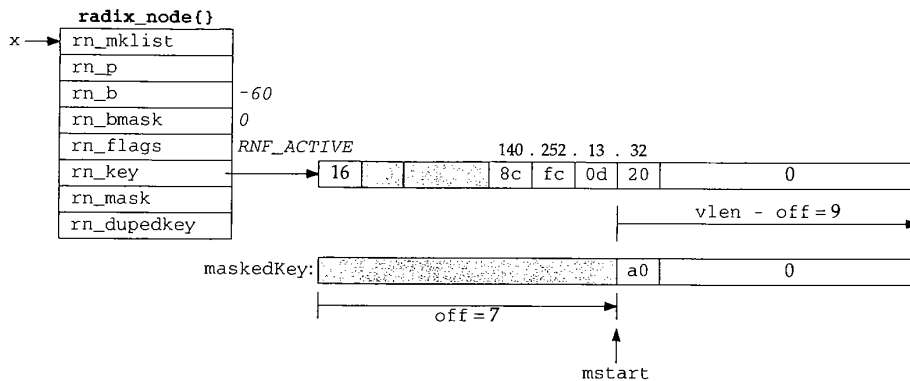

Figure 18.46 Comparison of maskedKey and new leaf.

Since the 9-byte strings are not the same, the comparison fails.

212-221

This while loop handles duplicate keys, each with a different mask. The only key of the duplicates that is compared is the one whose rn\_mask pointer equals m->rm\_mask. As an example, recall Figures 18.36 and 18.37. If the search starts at the node for bit 63, the first time through the inner do while loop m points to the radix\_mask structure for 0xffffffff00. When rn\_search returns the pointer to the first of the duplicate leaves for 127.0.0.0, the rm\_mask of this leaf equals m->rm\_mask, so Bcmp is called. If the comparison fails, m is replaced with the pointer to the next radix\_mask structure on the list (the one with a mask of 0xff000000) and the do while loop iterates around again with the new mask. rn\_search again returns the pointer to the first of the duplicate leaves for 127.0.0.0, but its rn\_mask does not equal m->rm\_mask. The while steps to the next of the duplicate leaves and its rn\_mask is the right one.

Returning to our example with the search key of 140.252.13.188, since the search from the node that tests bit 62 failed, the backtracking continues up the tree until the top is reached, which is the next node up the tree with a nonnull rn\_mklist.

Figure 18.47 shows the data structures when the top node of the tree is reached. At this point maskedKey is computed (it is all zero bits) and rn\_search starts at this node (the top of the tree) and continues down the two left branches to the leaf labeled "default" in Figure 18.4.

When rn\_search returns, x points to the radix\_node with an rn\_b of -33, which is the first leaf encountered after the two left branches from the top of the tree. But x->rn\_mask (which is null) does not equal m->rm\_mask, so x is replaced with x->rn\_dupedkey. The test of the while loop occurs again, but now x->rn\_mask equals m->rm\_mask, so the while loop terminates. Bcmp compares the 12 bytes of 0 starting at mstart with the 12 bytes of 0 stating at x->rn\_key plus 4, and since they're equal, the function returns the pointer x, which points to the entry for the default route.

g-
he

ift
9
32
ta

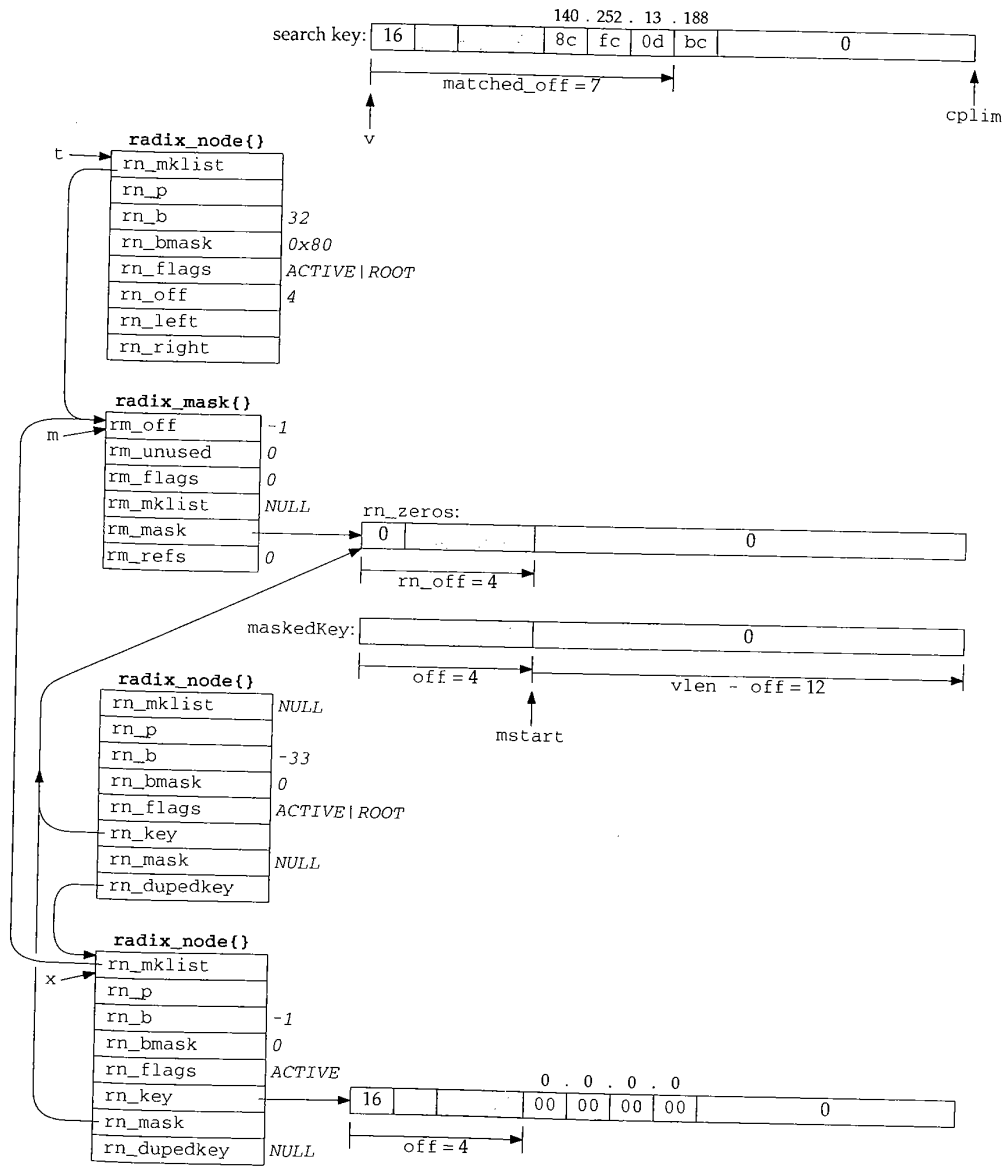

Figure 18.47 Backtrack to top of tree and rn\_search that locates default leaf.

### 18.11 rn\_search Function

rn\_search was called in the previous section from rn\_match to search a subtree of the routing table.

```

79 struct radix_node *
80 rn_search(v_arg, head)
81 void *v_arg;
82 struct radix_node *head;
83 {
84     struct radix_node *x;
85     caddr_t v;
86     for (x = head, v = v_arg; x->rn_b >= 0;) {
87         if (x->rn_bmask & v[x->rn_off])
88             x = x->rn_r; /* right if bit on */
89         else
90             x = x->rn_l; /* left if bit off */
91     }
92     return (x);
93 };

```

Figure 18.48 rn\_search function.

This loop is similar to the one in Figure 18.38. It compares one bit in the search key at each node, branching left if the bit is off or right if the bit is on, terminating when a leaf is encountered. The pointer to that leaf is returned.

### 18.12 Summary

Each routing table entry is identified by a key: the destination IP address in the case of the Internet protocols, which is either a host address or a network address with an associated network mask. Once the entry is located by searching for the key, additional information in the entry specifies the IP address of a router to which datagrams should be sent for the destination, a pointer to the interface to use, metrics, and so on.

The information maintained by the Internet protocols is the `route` structure, composed of just two elements: a pointer to a routing table entry and the destination address. We'll encounter one of these `route` structures in each of the Internet protocol control blocks used by UDP, TCP, and raw IP.

The Patricia tree data structure is well suited to routing tables. Routing table lookups occur much more frequently than adding or deleting routes, so from a performance standpoint using Patricia trees for the routing table makes sense. Patricia trees provide fast lookups at the expense of additional work in adding and deleting. Measurements in [Sklower 1991] comparing the radix tree approach to the Net/1 hash table show that the radix tree method is about two times faster in building a test tree and four times faster in searching.

### Exercises

- 18.1 We said with Figure 18.3 that the general condition for matching a routing table entry is that the search key logically ANDed with the routing table mask equal the routing table key. But in Figure 18.40 a different test is used. Build a logic truth table showing that the two tests are the same.
- 18.2 Assume a Net/3 system needs a routing table with 20,000 entries (IP addresses). Approximately how much memory is required for this, ignoring the space required for the masks?
- 18.3 What is the limit imposed on the length of a routing table key by the `radix_node` structure?

# 19

## *Routing Requests and Routing Messages*

### 19.1 Introduction

The various protocols within the kernel don't access the routing trees directly, using the functions from the previous chapter, but instead call a few functions that we describe in this chapter: `rtalloc` and `rtalloc1` are two that perform routing table lookups, `rtrequest` adds and deletes routing table entries, and `rtinit` is called by most interfaces when the interface goes up or down.

Routing messages communicate information in two directions. A process such as the `route` command or one of the routing daemons (`routed` or `gated`) writes routing messages to a routing socket, causing the kernel to add a new route, delete an existing route, or modify an existing route. The kernel also generates routing messages that can be read by any routing socket when events occur in which the processes might be interested: an interface has gone down, a redirect has been received, and so on. In this chapter we cover the formats of these routing messages and the information contained therein, and we save our discussion of routing sockets until the next chapter.

Another interface provided by the kernel to the routing tables is through the `sysctl` system call, which we describe at the end of this chapter. This system call allows a process to read the entire routing table or a list of all the configured interfaces and interface addresses.

### 19.2 `rtalloc` and `rtalloc1` Functions

`rtalloc` and `rtalloc1` are the functions normally called to look up an entry in the routing table. Figure 19.1 shows `rtalloc`.

```

58 void
59 rtalloc(ro)
60 struct route *ro;
61 {
62     if (ro->ro_rt && ro->ro_rt->rt_ifp && (ro->ro_rt->rt_flags & RTF_UP))
63         return; /* XXX */
64     ro->ro_rt = rtalloc1(&ro->ro_dst, 1);
65 }

```

Figure 19.1 rtalloc function.

<sup>58-65</sup> The argument *ro* is often the pointer to a route structure contained in an Internet PCB (Chapter 22) which is used by UDP and TCP. If *ro* already points to an *rtentry* structure (*ro\_rt* is nonnull), and that structure points to an interface structure, and the route is up, the function returns. Otherwise *rtalloc1* is called with a second argument of 1. We'll see the purpose of this argument shortly.

*rtalloc1*, shown in Figure 19.2, calls the *rnmatchaddr* function, which is always *rnmatch* (Figure 18.17) for Internet addresses.

<sup>66-76</sup> The first argument is a pointer to a socket address structure containing the address to search for. The *sa\_family* member selects the routing table to search.

#### Call *rnmatch*

<sup>77-78</sup> If the following three conditions are met, the search is successful.

1. A routing table exists for the protocol family,
2. *rnmatch* returns a nonnull pointer, and
3. the matching *radix\_node* does not have the *RNF\_ROOT* flag set.

Remember that the two leaves that mark the end of the tree both have the *RNF\_ROOT* flag set.

#### Search fails

<sup>94-101</sup> If the search fails because any one of the three conditions is not met, the statistic *rts\_unreach* is incremented and if the second argument to *rtalloc1* (*report*) is nonzero, a routing message is generated that can be read by any interested processes on a routing socket. The routing message has the type *RTM\_MISS*, and the function returns a null pointer.

<sup>79</sup> If all three of the conditions are met, the lookup succeeded and the pointer to the matching *radix\_node* is stored in *rt* and *newrt*. Notice that in the definition of the *rtentry* structure (Figure 18.24) the two *radix\_node* structures are at the beginning, and, as shown in Figure 18.8, the first of these two structures contains the leaf node. Therefore the pointer to a *radix\_node* structure returned by *rnmatch* is really a pointer to an *rtentry* structure, which is the matching leaf node.

ute.c

ute.c

rnet  
try  
the  
rgu-

h is

ress

OOT

istic  
) is  
s on  
rnsthe  
the  
ing,  
ode.  
ly a

```

66 struct rtenry *
67 rtalloc1(dst, report)
68 struct sockaddr *dst;
69 int report;
70 {
71     struct radix_node_head *rn timer = rt_tables[dst->sa_family];
72     struct rtenry *rt;
73     struct radix_node *rn;
74     struct rtenry *newrt = 0;
75     struct rt_addrinfo info;
76     int s = splnet(), err = 0, msgtype = RTM_MISS;
77     if (rn timer && (rn = rn timer->rn timer_matchaddr((caddr_t) dst, rn timer)) &&
78         ((rn->rn_flags & RNF_ROOT) == 0)) {
79         newrt = rt = (struct rtenry *) rn;
80         if (report && (rt->rt_flags & RTF_CLONING)) {
81             err = rtrequest(RTM_RESOLVE, dst, SA(0),
82                           SA(0), 0, &newrt);
83             if (err) {
84                 newrt = rt;
85                 rt->rt_refcnt++;
86                 goto miss;
87             }
88             if ((rt = newrt) && (rt->rt_flags & RTF_XRESOLVE)) {
89                 msgtype = RTM_RESOLVE;
90                 goto miss;
91             }
92         } else
93             rt->rt_refcnt++;
94     } else {
95         rtstat.rts_unreach++;
96         miss:if (report) {
97             bzero((caddr_t) & info, sizeof(info));
98             info.rti_info[RTAX_DST] = dst;
99             rt_missmsg(msgtype, &info, 0, err);
100         }
101     }
102     splx(s);
103     return (newrt);
104 }

```

Figure 19.2 rtalloc1 function.

**Create clone entries**

80-82 If the caller specified a nonzero second argument, and if the RTF\_CLONING flag is set, rtrequest is called with a command of RTM\_RESOLVE to create a new rtenry structure that is a clone of the one that was located. This feature is used by ARP and for multicast addresses.

**Clone creation fails**

83-87 If `rtrequest` returns an error, `newrt` is set back to the entry returned by `rn_match` and its reference count is incremented. A jump is made to `miss` where an `RTM_MISS` message is generated.

**Check for external resolution**

88-91 If `rtrequest` succeeds but the newly cloned entry has the `RTF_XRESOLVE` flag set, a jump is made to `miss`, this time to generate an `RTM_RESOLVE` message. The intent of this message is to notify a user process when the route is created, and it could be used with the conversion of IP addresses to X.121 addresses.

**Increment reference count for normal successful search**

92-93 When the search succeeds but the `RTF_CLONING` flag is not set, this statement increments the entry's reference count. This is the normal flow through the function, which then returns the nonnull pointer.

For a small function, `rtalloc1` has many options in how it operates. There are seven different flows through the function, summarized in Figure 19.3.

	report argument	RTF_-CLONING flag	RTM_-RESOLVE return	RTF_-XRESOLVE flag	routing message generated	rt_refcnt	return value
entry not found	0						null
	1				RTM_MISS		null
entry found		0				++	ptr
	0					++	ptr
	1	1	OK	0		++	ptr
	1	1	OK	1	RTM_RESOLVE	++	ptr
	1	1	error		RTM_MISS	++	ptr

Figure 19.3 Summary of operation of `rtalloc1`.

We note that the first two rows (entry not found) are impossible if a default route exists. Also we show `rt_refcnt` being incremented in the fifth and sixth rows when the call to `rtrequest` with a command of `RTM_RESOLVE` is OK. The increment is done by `rtrequest`.

### 19.3 RTFREE Macro and `rtfree` Function

The `RTFREE` macro, shown in Figure 19.4, calls the `rtfree` function only if the reference count is less than or equal to 1, otherwise it just decrements the reference count.

209-213 The `rtfree` function, shown in Figure 19.5, releases an `rtentry` structure when there are no more references to it. We'll see in Figure 22.7, for example, that when a protocol control block is released, if it points to a routing entry, `rtfree` is called.



defined by  
here an

flag set,  
intent of  
be used

statement  
function,

here are

return value
--------------

null
null
ptr
ptr
ptr
ptr
ptr

exists.  
the call  
done by

reference  
unt.  
e when  
when a

```

209 #define RTFREE(rt) \
210     if ((rt)->rt_refcnt <= 1) \
211         rtfree(rt); \
212     else \
213         (rt)->rt_refcnt--; /* no need for function call */

```

route.h

Figure 19.4 RTFREE macro.

```

105 void
106 rtfree(rt)
107 struct rtentry *rt;
108 {
109     struct ifaddr *ifa;
110     if (rt == 0)
111         panic("rtfree");
112     rt->rt_refcnt--;
113     if (rt->rt_refcnt <= 0 && (rt->rt_flags & RTF_UP) == 0) {
114         if (rt->rt_nodes->rn_flags & (RNF_ACTIVE | RNF_ROOT))
115             panic("rtfree 2");
116         rttrash--;
117         if (rt->rt_refcnt < 0) {
118             printf("rtfree: %x not freed (neg refs)\n", rt);
119             return;
120         }
121         ifa = rt->rt_ifa;
122         IFAFREE(ifa);
123         Free(rt_key(rt));
124         Free(rt);
125     }
126 }

```

route.c

Figure 19.5 rtfree function: release an rtentry structure.

105-115 The entry's reference count is decremented and if it is less than or equal to 0 and the route is not usable, the entry can be released. If either of the flags RNF\_ACTIVE or RNF\_ROOT are set, this is an internal error. If RNF\_ACTIVE is set, this structure is still part of the routing table tree. If RNF\_ROOT is set, this structure is one of the end markers built by rn\_inithead.

116 rttrash is a debugging counter of the number of routing entries not in the routing tree, but not released. It is incremented by rtrequest when it begins deleting a route, and then decremented here. Its value should normally be 0.

#### Release interface reference

117-122 A check is made that the reference count is not negative, and then IFAFREE decrements the reference count for the ifaddr structure and releases it by calling ifafree when it reaches 0.

### Release routing memory

123-124 The memory occupied by the routing entry key and its gateway is released. We'll see in `rt_setgate` that the memory for both is allocated in one contiguous chunk, allowing both to be released with a single call to `Free`. Finally the `rtentry` structure itself is released.

### Routing Table Reference Counts

The handling of the routing table reference count, `rt_refcnt`, differs from most other reference counts. We see in Figure 18.2 that most routes have a reference count of 0, yet the routing table entries without any references are not deleted. We just saw the reason in `rtfree`: an entry with a reference count of 0 is not deleted unless the entry's `RTF_UP` flag is not set. The only time this flag is cleared is by `rtrequest` when a route is deleted from the routing tree.

Most routes are used in the following fashion.

- If the route is created automatically as a route to an interface when the interface is configured (which is typical for Ethernet interfaces, for example), then `rtinit` calls `rtrequest` with a command of `RTM_ADD`, creating the new entry and setting the reference count to 1. `rtinit` then decrements the reference count to 0 before returning.

A point-to-point interface follows a similar procedure, so the route starts with a reference count of 0.

If the route is created manually by the `route` command or by a routing daemon, a similar procedure occurs, with `route_output` calling `rtrequest` with a command of `RTM_ADD`, setting the reference count to 1. This is then decremented by `route_output` to 0 before it returns.

Therefore all newly created routes start with a reference count of 0.

- When an IP datagram is sent on a socket, be it TCP or UDP, we saw that `ip_output` calls `rtalloc`, which calls `rtalloc1`. In Figure 19.3 we saw that the reference count is incremented by `rtalloc1` if the route is found.

The located route is called a *held route*, since a pointer to the routing table entry is being held by the protocol, normally in a `route` structure contained within a protocol control block. An `rtentry` structure that is being held by someone else cannot be deleted, which is why `rtfree` doesn't release the structure until its reference count reaches 0.

- A protocol releases a held route by calling `RTFREE` or `rtfree`. We saw this in Figure 8.24 when `ip_output` detects a change in the destination address. We'll encounter it in Chapter 22 when a protocol control block that holds a route is released.

Part of the confusion we'll encounter in the code that follows is that `rtalloc1` is often called to look up a route in order to verify that a route to the destination exists, but

when the caller doesn't want to hold the route. Since `rtalloc1` increments the counter, the caller immediately decrements it.

Consider a route being deleted by `rtrequest`. The `RTF_UP` flag is cleared, and if no one is holding the route (its reference count is 0), `rtfree` should be called. But `rtfree` considers it an error for the reference count to go below 0, so `rtrequest` checks whether its reference count is less than or equal to 0, and, if so, increments it and calls `rtfree`. Normally this sets the reference count to 1 and `rtfree` decrements it to 0 and deletes the route.

## 19.4 rtrequest Function

The `rtrequest` function is the focal point for adding and deleting routing table entries. Figure 19.6 shows some of the other functions that call it.

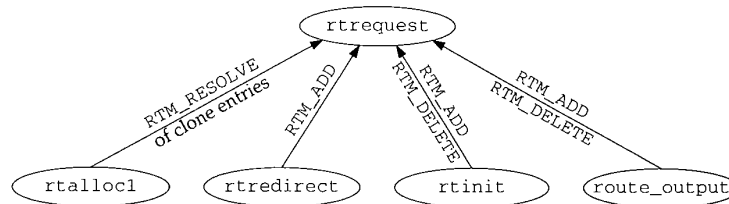

Figure 19.6 Summary of functions that call `rtrequest`.

`rtrequest` is a switch statement with one case per command: `RTM_ADD`, `RTM_DELETE`, and `RTM_RESOLVE`. Figure 19.7 shows the start of the function and the `RTM_DELETE` command.

```

                                                                    route.c
290 int
291 rtrequest(req, dst, gateway, netmask, flags, ret_nrt)
292 int req, flags;
293 struct sockaddr *dst, *gateway, *netmask;
294 struct rtentry **ret_nrt;
295 {
296     int s = splnet();
297     int error = 0;
298     struct rtentry *rt;
299     struct radix_node *rn;
300     struct radix_node_head *rn timer;
301     struct ifaddr *ifa;
302     struct sockaddr *ndst;
303 #define senderr(x) { error = x ; goto bad; }
304     if ((rn timer = rt_tables[dst->sa_family]) == 0)
305         senderr(ESRCH);
306     if (flags & RTF_HOST)
307         netmask = 0;

```

```

308     switch (req) {
309     case RTM_DELETE:
310         if ((rn = rnh->rn_deladdr(dst, netmask, rnh)) == 0)
311             senderr(ESRCH);
312         if (rn->rn_flags & (RNF_ACTIVE | RNF_ROOT))
313             panic("rtrequest delete");
314         rt = (struct rtable *) rn;
315         rt->rt_flags &= ~RTF_UP;
316         if (rt->rt_gwroute) {
317             rt = rt->rt_gwroute;
318             RTFREE(rt);
319             (rt = (struct rtable *) rn)->rt_gwroute = 0;
320         }
321         if ((ifa = rt->rt_ifa) && ifa->ifa_rtrequest)
322             ifa->ifa_rtrequest(RTM_DELETE, rt, SA(0));
323         rtrtrash++;
324         if (ret_nrt)
325             *ret_nrt = rt;
326         else if (rt->rt_refcnt <= 0) {
327             rt->rt_refcnt++;
328             rtfree(rt);
329         }
330         break;

```

route.c

Figure 19.7 rtrequest function: RTM\_DELETE command.

290-307 The second argument, *dst*, is a socket address structure specifying the key to be added or deleted from the routing table. The *sa\_family* from this key selects the routing table. If the *flags* argument indicates a host route (instead of a route to a network), the *netmask* pointer is set to null, ignoring any value the caller may have passed.

#### Delete from routing tree

309-315 The *rn\_deladdr* function (*rn\_delete* from Figure 18.17) deletes the entry from the routing table tree and returns a pointer to the corresponding *rtable* structure. The *RTF\_UP* flag is cleared.

#### Remove reference to gateway routing table entry

316-320 If the entry is an indirect route through a gateway, *RTFREE* decrements the *rt\_refcnt* member of the gateway's entry and deletes it if the count reaches 0. The *rt\_gwroute* pointer is set to null and *rt* is set back to point to the entry that was deleted.

#### Call interface request function

321-322 If an *ifa\_rtrequest* function is defined for this entry, that function is called. This function is used by ARP, for example, in Chapter 21 to delete the corresponding ARP entry.

#### Return pointer or release reference

323-330 The *rtrtrash* global is incremented because the entry may not be released in the code that follows. If the caller wants the pointer to the *rtable* structure that was

deleted from the routing tree (if `ret_nrt` is nonnull), then that pointer is returned, but the entry cannot be released: it is the caller's responsibility to call `rtfree` when it is finished with the entry. If `ret_nrt` is null, the entry can be released: if the reference count is less than or equal to 0, it is incremented, and `rtfree` is called. The `break` causes the function to return.

Figure 19.8 shows the next part of the function, which handles the `RTM_RESOLVE` command. This function is called with this command only from `rtalloc1`, when a new entry is to be created from an entry with the `RTF_CLONING` flag set.

```

331     case RTM_RESOLVE:
332         if (ret_nrt == 0 || (rt = *ret_nrt) == 0)
333             senderr(EINVAL);
334         ifa = rt->rt_ifa;
335         flags = rt->rt_flags & ~RTF_CLONING;
336         gateway = rt->rt_gateway;
337         if ((netmask = rt->rt_genmask) == 0)
338             flags |= RTF_HOST;
339         goto makeroute;

```

Figure 19.8 `rtrequest` function: `RTM_RESOLVE` command.

The final argument, `ret_nrt`, is used differently for this command: it contains the pointer to the entry with the `RTF_CLONING` flag set (Figure 19.2). The new entry will have the same `rt_ifa` pointer, the same flags (with the `RTF_CLONING` flag cleared), and the same `rt_gateway`. If the entry being cloned has a null `rt_genmask` pointer, the new entry has its `RTF_HOST` flag set, because it is a host route; otherwise the new entry is a network route and the network mask of the new entry is copied from the `rt_genmask` value. We give an example of cloned routes with a network mask at the end of this section. This case continues at the label `makeroute`, which is in the next figure.

Figure 19.9 shows the `RTM_ADD` command.

#### Locate corresponding interface

The function `ifa_ifwithroute` finds the appropriate local interface for the destination (`dst`), returning a pointer to its `ifaddr` structure.

#### Allocate memory for routing table entry

An `rtentry` structure is allocated. Recall that this structure contains both the two `radix_node` structures for the routing tree and the other routing information. The structure is zeroed and the `rt_flags` are set from the caller's flags, including the `RTF_UP` flag.

#### Allocate and copy gateway address

The `rt_setgate` function (Figure 19.11) allocates memory for both the routing table key (`dst`) and its gateway. It then copies `gateway` into the new memory and sets the pointers `rt_key`, `rt_gateway`, and `rt_gwroute`.

```

340 case RTM_ADD:
341     if ((ifa = ifa_ifwithroute(flags, dst, gateway)) == 0)
342         senderr(ENETUNREACH);
343     makeroute:
344         R_Malloc(rt, struct rtentry *, sizeof(*rt));
345         if (rt == 0)
346             senderr(ENOBUFS);
347         Bzero(rt, sizeof(*rt));
348         rt->rt_flags = RTF_UP | flags;
349         if (rt_setgate(rt, dst, gateway) {
350             Free(rt);
351             senderr(ENOBUFS);
352         }
353         ndst = rt_key(rt);
354         if (netmask) {
355             rt_maskedcopy(dst, ndst, netmask);
356         } else
357             Bcopy(dst, ndst, dst->sa_len);
358         rn = rnh->rnh_addaddr((caddr_t) ndst, (caddr_t) netmask,
359                             rnh, rt->rt_nodes);
360         if (rn == 0) {
361             if (rt->rt_gwroute)
362                 rtfree(rt->rt_gwroute);
363             Free(rt_key(rt));
364             Free(rt);
365             senderr(EEXIST);
366         }
367         ifa->ifa_refcnt++;
368         rt->rt_ifa = ifa;
369         rt->rt_ifp = ifa->ifa_ifp;
370         if (req == RTM_RESOLVE)
371             rt->rt_rmx = (*ret_nrt)->rt_rmx; /* copy metrics */
372         if (ifa->ifa_rtrequest)
373             ifa->ifa_rtrequest(req, rt, SA(ret_nrt ? *ret_nrt : 0));
374         if (ret_nrt) {
375             *ret_nrt = rt;
376             rt->rt_refcnt++;
377         }
378         break;
379     }
380 bad:
381     splx(s);
382     return (error);
383 }

```

Figure 19.9 rtrequest function: RTM\_ADD command.

#### Copy destination address

353-357 The destination address (the routing table key *dst*) must now be copied into the memory pointed to by *rn\_key*. If a network mask is supplied, *rt\_maskedcopy* logically ANDs *dst* and *netmask*, forming the new key. Otherwise *dst* is copied into the

ite.c

new key. The reason for logically ANDing `dst` and `netmask` is to guarantee that the key in the table has already been ANDed with its mask, so when a search key is compared against the key in the table only the search key needs to be ANDed. For example, the following command adds another IP address (an alias) to the Ethernet interface `le0`, with subnet 12 instead of 13:

```
bsd1 $ ifconfig le0 inet 140.252.12.63 netmask 0xfffffe0 alias
```

The problem is that we've incorrectly specified all one bits for the host ID. Nevertheless, when the key is stored in the routing table we can verify with `netstat` that the address is first logically ANDed with the mask:

Destination	Gateway	Flags	Refs	Use	Interface
140.252.12.32	link#1	U C	0	0	le0

#### Add entry to routing tree

358-366 The `rn_h_addaddr` function (`rn_addroute` from Figure 18.17) adds this `rte` structure, with its destination and mask, to the routing table tree. If an error occurs, the structures are released and `EEXIST` returned (i.e., the entry is already in the routing table).

#### Store interface pointers

367-369 The `ifa_addr` structure's reference count is incremented and the pointers to its `ifa_addr` and `ifa_net` structures are stored.

#### Copy metrics for newly cloned route

370-371 If the command was `RTM_RESOLVE` (not `RTM_ADD`), the entire metrics structure is copied from the cloned entry into the new entry. If the command was `RTM_ADD`, the caller can set the metrics after this function returns.

#### Call interface request function

372-373 If an `ifa_rtrequest` function is defined for this entry, that function is called. ARP uses this to perform additional processing for both the `RTM_ADD` and `RTM_RESOLVE` commands (Section 21.13).

#### Return pointer and increment reference count

374-378 If the caller wants a copy of the pointer to the new structure, it is returned through `ret_nrt` and the `rt_refcnt` reference count is incremented from 0 to 1.

### Example: Cloned Routes with Network Masks

oute.c

The only use of the `rt_genmask` value is with cloned routes created by the `RTM_RESOLVE` command in `rtrequest`. If an `rt_genmask` pointer is nonnull, then the socket address structure pointed to by this pointer becomes the network mask of the newly created route. In our routing table, Figure 18.2, the cloned routes are for the local Ethernet and for multicast addresses. The following example from [Sklower 1991] provides a different use of cloned routes. Another example is in Exercise 19.2.

o the  
logi-  
o the

Consider a class B network, say 128.1, that is behind a point-to-point link. The subnet mask is `0xfffff00`, the typical value that uses 8 bits for the subnet ID and 8 bits

for the host ID. We need a routing table entry for all possible 254 subnets, with a gateway value of a router that is directly connected to our host and that knows how to reach the link to which the 128.1 network is connected.

The easiest solution, assuming the gateway router isn't our default router, is a single entry with a destination of 128.1.0.0 and a mask of 0xffff0000. Assume, however, that the topology of the 128.1 network is such that each of the possible 254 subnets can have different operational characteristics: RTTs, MTUs, delays, and so on. If a separate routing table entry were used for each subnet, we would see that whenever a connection is closed, TCP would update the routing table entry with statistics about that route—its RTT, RTT variance, and so on (Figure 27.3). While we could create up to 254 entries by hand using the `route` command, one per subnet, a better solution is to use the cloning feature.

One entry is created by the system administrator with a destination of 128.1.0.0 and a network mask of 0xffff0000. Additionally, the `RTF_CLONING` flag is set and the `genmask` is set to 0xffffffff00, which differs from the network mask. If the routing table is searched for 128.1.2.3, and an entry does not exist for the 128.1.2 subnet, the entry for 128.1 with the mask of 0xffff0000 is the best match. A new entry is created (since the `RTF_CLONING` flag is set) with a destination of 128.1.2 and a network mask of 0xffffffff00 (the `genmask` value). The next time any host on this subnet is referenced, say 128.1.2.88, it will match this newly created entry.

## 19.5 `rt_setgate` Function

Each leaf in the routing tree has a key (`rt_key`, which is just the `rn_key` member of the `radix_node` structure contained at the beginning of the `rtentry` structure), and an associated gateway (`rt_gateway`). Both are socket address structures specified when the routing table entry is created. Memory is allocated for both structures by `rt_setgate`, as shown in Figure 19.10.

This example shows two of the entries from Figure 18.2, the ones with keys of 127.0.0.1 and 140.252.13.33. The former's gateway member points to an Internet socket address structure, while the latter's points to a data-link socket address structure that contains an Ethernet address. The former was entered into the routing table by the `route` system when the system was initialized, and the latter was created by ARP.

We purposely show the two structures pointed to by `rt_key` one right after the other, since they are allocated together by `rt_setgate`, which we show in Figure 19.11.

### Set lengths from socket address structures

384-391 `dlen` is the length of the destination socket address structure, and `glen` is the length of the gateway socket address structure. The `ROUNDUP` macro rounds the value up to the next multiple of 4 bytes, but the size of most socket address structures is already a multiple of 4.



ite-  
ach  
gle  
ver,  
can  
ate  
ec-  
hat  
254  
use

and  
the  
ing  
the  
ted  
k of  
ced,

the  
l an  
hen  
by

s of  
cket  
that  
the

the  
9.11.

the  
alue  
es is

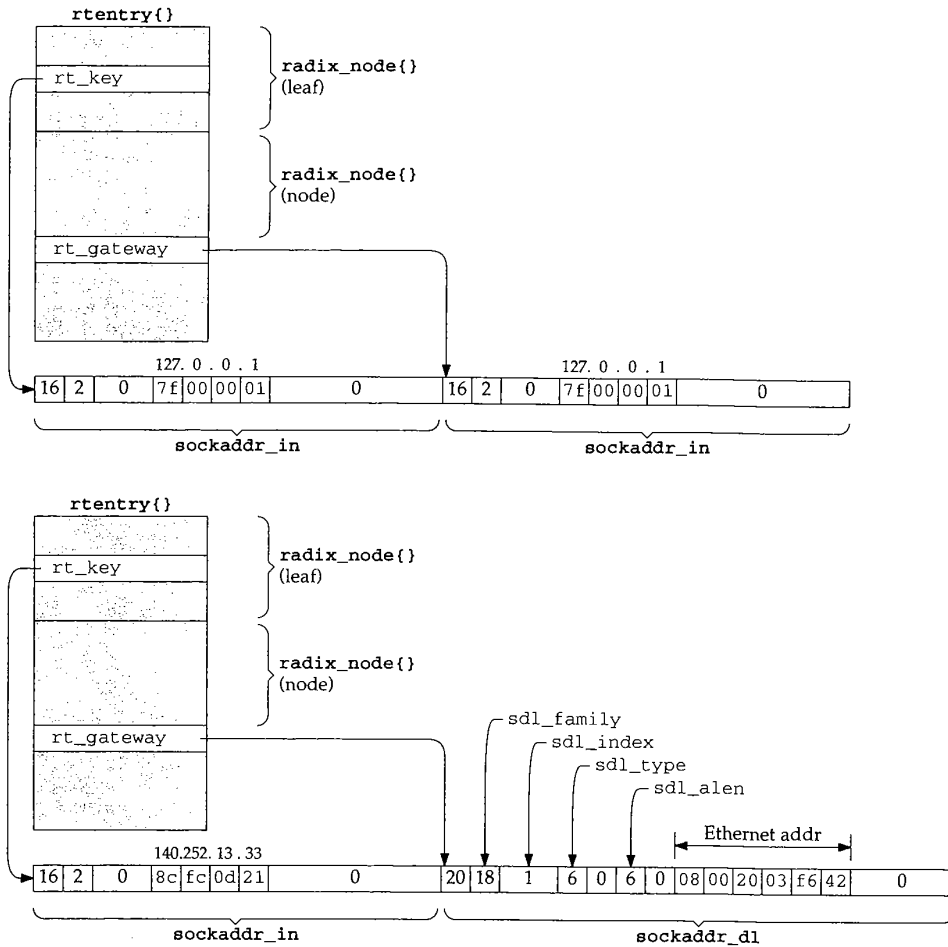

Figure 19.10 Example of routing table keys and associated gateways.

**Allocate memory**

392-397 If memory has not been allocated for this routing table key and gateway yet, or if `rlen` is greater than the current size of the structure pointed to by `rt_gateway`, a new piece of memory is allocated and `rn_key` is set to point to the new memory.

**Use memory already allocated for key and gateway**

398-401 An adequately sized piece of memory is already allocated for the key and gateway, so `rn_key` is set to point to this existing memory.

```

384 int
385 rt_setgate(rt0, dst, gate)
386 struct rtable *rt0;
387 struct sockaddr *dst, *gate;
388 {
389     caddr_t new, old;
390     int     dlen = ROUNDUP(dst->sa_len), glen = ROUNDUP(gate->sa_len);
391     struct rtable *rt = rt0;
392
393     if (rt->rt_gateway == 0 || glen > ROUNDUP(rt->rt_gateway->sa_len)) {
394         old = (caddr_t) rt_key(rt);
395         R_Malloc(new, caddr_t, dlen + glen);
396         if (new == 0)
397             return 1;
398         rt->rt_nodes->rn_key = new;
399     } else {
400         new = rt->rt_nodes->rn_key;
401         old = 0;
402     }
403     Bcopy(gate, (rt->rt_gateway = (struct sockaddr *) (new + dlen)), glen);
404     if (old) {
405         Bcopy(dst, new, dlen);
406         Free(old);
407     }
408     if (rt->rt_gwroute) {
409         rt = rt->rt_gwroute;
410         RTFREE(rt);
411         rt = rt0;
412         rt->rt_gwroute = 0;
413     }
414     if (rt->rt_flags & RTF_GATEWAY) {
415         rt->rt_gwroute = rtalloc1(gate, 1);
416     }
417     return 0;
418 }

```

Figure 19.11 rt\_setgate function.

**Copy new gateway**

402 The new gateway structure is copied and `rt_gateway` is set to point to the socket address structure.

**Copy key from old memory to new memory**

403-406 If a new piece of memory was allocated, the routing table key (`dst`) is copied right before the gateway field that was just copied. The old piece of memory is released.

**Release gateway routing pointer**

407-412 If the routing table entry contains a nonnull `rt_gwroute` pointer, that structure is released by `RTFREE` and the `rt_gwroute` pointer is set to null.

— route.c

n);

n) {

, glen);

— route.c

the socket

copied right  
eased.

structure is

#### Locate and store new gateway routing pointer

413-415 If the routing table entry is an indirect route, `rtalloc1` locates the entry for the new gateway, which is stored in `rt_gwroute`. If an invalid gateway is specified for an indirect route, an error is not returned by `rt_setgate`, but the `rt_gwroute` pointer will be null.

## 19.6 rtinit Function

There are four calls to `rtinit` from the Internet protocols to add or delete routes associated with interfaces.

- `in_control` calls `rtinit` twice when the destination address of a point-to-point interface is set (Figure 6.21). The first call specifies `RTM_DELETE` to delete any existing route to the destination; the second call specifies `RTM_ADD` to add the new route.
- `in_ifinit` calls `rtinit` to add a network route for a broadcast network or a host route for a point-to-point link (Figure 6.19). If the route is for an Ethernet interface, the `RTF_CLONING` flag is automatically set by `in_ifinit`.
- `in_ifscrub` calls `rtinit` to delete an existing route for an interface.

Figure 19.12 shows the first part of the `rtinit` function. The `cmd` argument is always `RTM_ADD` or `RTM_DELETE`.

#### Get destination address for route

452 If the route is to a host, the destination address is the other end of the point-to-point link. Otherwise we're dealing with a network route and the destination address is the unicast address of the interface (masked with `ifa_netmask`).

#### Mask network address with network mask

453-459 If a route is being deleted, the destination must be looked up in the routing table to locate its routing table entry. If the route being deleted is a network route and the interface has an associated network mask, an mbuf is allocated and the destination address is copied into the mbuf by `rt_maskedcopy`, logically ANDing the caller's address with the mask. `dst` is set to point to the masked copy in the mbuf, and that is the destination looked up in the next step.

#### Search for routing table entry

460-469 `rtalloc1` searches the routing table for the destination address. If the entry is found, its reference count is decremented (since `rtalloc1` incremented the reference count). If the pointer to the interface's `ifaddr` in the routing table does not equal the caller's argument, an error is returned.

#### Process request

470-473 `rtrequest` executes the command, either `RTM_ADD` or `RTM_DELETE`. When it returns, if an mbuf was allocated earlier, it is released.

```

441 int
442 rtinit(ifa, cmd, flags)
443 struct ifaddr *ifa;
444 int      cmd, flags;
445 {
446     struct rtentry *rt;
447     struct sockaddr *dst;
448     struct sockaddr *deldst;
449     struct mbuf *m = 0;
450     struct rtentry *nrt = 0;
451     int      error;

452     dst = flags & RTF_HOST ? ifa->ifa_dstaddr : ifa->ifa_addr;
453     if (cmd == RTM_DELETE) {
454         if ((flags & RTF_HOST) == 0 && ifa->ifa_netmask) {
455             m = m_get(M_WAIT, MT_SONAME);
456             deldst = mtod(m, struct sockaddr *);
457             rt_maskedcopy(dst, deldst, ifa->ifa_netmask);
458             dst = deldst;
459         }
460         if (rt = rtallocl(dst, 0)) {
461             rt->rt_refcnt--;
462             if (rt->rt_ifa != ifa) {
463                 if (m)
464                     (void) m_free(m);
465                 return (flags & RTF_HOST ? EHOSTUNREACH
466                     : ENETUNREACH);
467             }
468         }
469     }
470     error = rtrequest(cmd, dst, ifa->ifa_addr, ifa->ifa_netmask,
471                     flags | ifa->ifa_flags, &nrt);
472     if (m)
473         (void) m_free(m);

```

Figure 19.12 rtinit function: call rtrequest to handle command.

Figure 19.13 shows the second half of rtinit.

#### Generate routing message on successful delete

474-480 If a route was deleted, and rtrequest returned 0 along with a pointer to the rtentry structure that was deleted (in nrt), a routing socket message is generated by rt\_newaddrmsg. If the reference count is less than or equal to 0, it is incremented and the route is released by rtfree.

#### Successful add

481-482 If a route was added, and rtrequest returned 0 along with a pointer to the rtentry structure that was added (in nrt), the reference count is decremented (since rtrequest incremented it).

```

474     if (cmd == RTM_DELETE && error == 0 && (rt = nrt)) {
475         rt_newaddrmsg(cmd, ifa, error, nrt);
476         if (rt->rt_refcnt <= 0) {
477             rt->rt_refcnt++;
478             rtfree(rt);
479         }
480     }
481     if (cmd == RTM_ADD && error == 0 && (rt = nrt)) {
482         rt->rt_refcnt--;
483         if (rt->rt_ifa != ifa) {
484             printf("rtinit: wrong ifa (%x) was (%x)\n", ifa,
485                 rt->rt_ifa);
486             if (rt->rt_ifa->ifa_rtrequest)
487                 rt->rt_ifa->ifa_rtrequest(RTM_DELETE, rt, SA(0));
488             IFAPFREE(rt->rt_ifa);
489             rt->rt_ifa = ifa;
490             rt->rt_ifp = ifa->ifa_ifp;
491             ifa->ifa_refcnt++;
492             if (ifa->ifa_rtrequest)
493                 ifa->ifa_rtrequest(RTM_ADD, rt, SA(0));
494         }
495         rt_newaddrmsg(cmd, ifa, error, nrt);
496     }
497     return (error);
498 }

```

*route.c*

*route.c*

Figure 19.13 rtinit function: second half.

**Incorrect interface**

483-494 If the pointer to the interface's `ifa_addr` in the new routing table entry does not equal the caller's argument, an error occurred. Recall that `rtrequest` determines the `ifa` pointer that is stored in the new entry by calling `ifa_ifwithroute` (Figure 19.9). When this error occurs the following steps take place: an error message is output to the console, the `ifa_rtrequest` function is called (if defined) with a command of `RTM_DELETE`, the `ifa_addr` structure is released, the `rt_ifa` pointer is set to the value specified by the caller, the interface reference count is incremented, and the new interface's `ifa_rtrequest` function (if defined) is called with a command of `RTM_ADD`.

**Generate routing message**

495 A routing socket message is generated by `rt_newaddrmsg` for the `RTM_ADD` command.

**19.7 rtredirect Function**

When an ICMP redirect is received, `icmp_input` calls `rtredirect` and then calls `pfctlinput` (Figure 11.27). This latter function calls `udp_ctlinput` and `tcp_ctlinput`, which go through all the UDP and TCP protocol control blocks. If the

PCB is connected to the foreign address that has been redirected, and if the PCB holds a route to that foreign address, the route is released by `rtfree`. The next time any of these control blocks is used to send an IP datagram to that foreign address, `rtalloc` will be called and the destination will be looked up in the routing table, possibly finding a new (redirected) route.

The purpose of `rtredirect`, the first half of which is shown in Figure 19.14, is to validate the information in the redirect, update the routing table immediately, and then generate a routing socket message.

```

147 int
148 rtredirect(dst, gateway, netmask, flags, src, rtp)
149 struct sockaddr *dst, *gateway, *netmask, *src;
150 int flags;
151 struct rtpentry **rtp;
152 {
153     struct rtpentry *rt;
154     int error = 0;
155     short *stat = 0;
156     struct rt_addrinfo info;
157     struct ifaddr *ifa;

158     /* verify the gateway is directly reachable */
159     if ((ifa = ifa_ifwithnet(gateway)) == 0) {
160         error = ENETUNREACH;
161         goto out;
162     }
163     rt = rtalloc(dst, 0);
164     /*
165      * If the redirect isn't from our current router for this dst,
166      * it's either old or wrong. If it redirects us to ourselves,
167      * we have a routing loop, perhaps as a result of an interface
168      * going down recently.
169      */
170     #define equal(a1, a2) (bcmp((caddr_t)(a1), (caddr_t)(a2), (a1)->sa_len) == 0)
171     if (!(flags & RTF_DONE) && rt &&
172         (!equal(src, rt->rt_gateway) || rt->rt_ifa != ifa))
173         error = EINVAL;
174     else if (ifa_ifwithaddr(gateway))
175         error = EHOSTUNREACH;
176     if (error)
177         goto done;
178     /*
179      * Create a new entry if we just got back a wildcard entry
180      * or if the lookup failed. This is necessary for hosts
181      * which use routing redirects generated by smart gateways
182      * to dynamically build the routing tables.
183      */
184     if ((rt == 0) || (rt_mask(rt) && rt_mask(rt)->sa_len < 2))
185         goto create;

```

Figure 19.14 `rtredirect` function: validate received redirect.

holds a  
any of  
alloc  
finding

l4, is to  
ad then

— route.c

147–157 The arguments are *dst*, the destination IP address of the datagram that caused the redirect (HD in Figure 8.18); *gateway*, the IP address of the router to use as the new gateway field for the destination (R2 in Figure 8.18); *netmask*, which is a null pointer; *flags*, which is `RTF_GATEWAY` and `RTF_HOST`; *src*, the IP address of the router that sent the redirect (R1 in Figure 8.18); and *rtp*, which is a null pointer. We indicate that *netmask* and *rtp* are both null pointers when called by `icmp_input`, but these arguments might be nonnull when called from other protocols.

#### New gateway must be directly connected

158–162 The new gateway must be directly connected or the redirect is invalid.

#### Locate routing table entry for destination and validate redirect

163–177 `rtalloc1` searches the routing table for a route to the destination. The following conditions must all be true, or the redirect is invalid and an error is returned. Notice that `icmp_input` ignores any error return from `rtredirect`. ICMP does not generate an error in response to an invalid redirect—it just ignores it.

- the `RTF_DONE` flag must not be set;
- `rtalloc` must have located a routing table entry for *dst*;
- the address of the router that sent the redirect (*src*) must equal the current `rt_gateway` for the destination;
- the interface for the new gateway (the *ifa* returned by `ifa_ifwithnet`) must equal the current interface for the destination (`rt_ifa`), that is, the new gateway must be on the same network as the current gateway; and
- the new gateway cannot redirect this host to itself, that is, there cannot exist an attached interface with a unicast address or a broadcast address equal to `gateway`.

#### Must create a new route

178–185 If a route to the destination was not found, or if the routing table entry that was located is the default route, a new entry is created for the destination. As the comment indicates, a host with access to multiple routers can use this feature to learn of the correct router when the default is not correct. The test for finding the default route is whether the routing table entry has an associated mask and if the length field of the mask is less than 2, since the mask for the default route is `rn_zeros` (Figure 18.35).

Figure 19.15 shows the second half of this function.

#### Create new host route

186–195 If the current route to the destination is a network route and the redirect is a host redirect and not a network redirect, a new host route is created for the destination and the existing network route is left alone. We mentioned that the `flags` argument always specifies `RTF_HOST` since the Net/3 ICMP considers all received redirects as host redirects.

en) == 0)

— route.c

```

186      /*
187      * Don't listen to the redirect if it's
188      * for a route to an interface.
189      */
190      if (rt->rt_flags & RTF_GATEWAY) {
191          if (((rt->rt_flags & RTF_HOST) == 0) && (flags & RTF_HOST)) {
192              /*
193              * Changing from route to net => route to host.
194              * Create new route, rather than smashing route to net.
195              */
196              create:
197              flags |= RTF_GATEWAY | RTF_DYNAMIC;
198              error = rtrequest((int) RTM_ADD, dst, gateway,
199                              netmask, flags,
200                              (struct rtentry **) 0);
201              stat = &rtstat.rts_dynamic;
202          } else {
203              /*
204              * Smash the current notion of the gateway to
205              * this destination. Should check about netmask!!!
206              */
207              rt->rt_flags |= RTF_MODIFIED;
208              flags |= RTF_MODIFIED;
209              stat = &rtstat.rts_newgateway;
210              rt_setgate(rt, rt_key(rt), gateway);
211          }
212      } else
213          error = EHOSTUNREACH;
214      done:
215      if (rt) {
216          if (rtp && !error)
217              *rtp = rt;
218          else
219              rtfree(rt);
220      }
221      out:
222      if (error)
223          rtstat.rts_badredirect++;
224      else if (stat != NULL)
225          (*stat)++;
226      bzero((caddr_t) & info, sizeof(info));
227      info.rti_info[RTAX_DST] = dst;
228      info.rti_info[RTAX_GATEWAY] = gateway;
229      info.rti_info[RTAX_NETMASK] = netmask;
230      info.rti_info[RTAX_AUTHOR] = src;
231      rt_missmsg(RTM_REDIRECT, &info, flags, error);
232  }

```

Figure 19.15 rtredirect function: second half.



route.c

**Create route**

196-201 `rtrequest` creates the new route, setting the `RTF_GATEWAY` and `RTF_DYNAMIC` flags. The `netmask` argument is a null pointer, since the new route is a host route with an implied mask of all one bits. `stat` points to a counter that is incremented later.

**Modify existing host route**

202-211 This code is executed when the current route to the destination is already a host route. A new entry is not created, but the existing entry is modified. The `RTF_MODIFIED` flag is set and `rt_setgate` changes the `rt_gateway` field of the routing table entry to the new gateway address.

**Ignore if destination is directly connected**

212-213 If the current route to the destination is a direct route (the `RTF_GATEWAY` flag is not set), it is a redirect for a destination that is already directly connected. `EHOSTUNREACH` is returned.

**Return pointer and increment statistic**

214-225 If a routing table entry was located, it is either returned (if `rtp` is nonnull and there were no errors) or released by `rt_free`. The appropriate statistic is incremented.

**Generate routing message**

226-232 An `rt_addrinfo` structure is cleared and a routing socket message is generated by `rt_missmsg`. This message is sent by `raw_input` to any processes interested in the redirect.

## 19.8 Routing Message Structures

Routing messages consist of a fixed-length header followed by up to eight socket address structures. The fixed-length header is one of the following three structures:

- `rt_msghdr`
- `if_msghdr`
- `ifa_msghdr`

Figure 18.11 provided an overview of which functions generated the different messages and Figure 18.9 showed which structure is used by each message type. The first three members of the three structures have the same data type and meaning: the message length, version, and type. This allows the receiver of the message to decode the message. Also, each structure has a member that encodes which of the eight potential socket address structures follow the structure (a bitmask): the `rtm_addrs`, `ifm_addrs`, and `ifam_addrs` members.

Figure 19.16 shows the most common of the structures, `rt_msghdr`. The `RTM_IFINFO` message uses an `if_msghdr` structure, shown in Figure 19.17. The `RTM_NEWADDR` and `RTM_DELADDR` messages use an `ifa_msghdr` structure, shown in Figure 19.18.

route.c

```

-----route.h
139 struct rt_msghdr {
140     u_short rtm_msglen;      /* to skip over non-understood messages */
141     u_char  rtm_version;    /* future binary compatibility */
142     u_char  rtm_type;       /* message type */
143     u_short rtm_index;      /* index for associated ifp */
144     int     rtm_flags;      /* flags, incl. kern & message, e.g. DONE */
145     int     rtm_addrs;     /* bitmask identifying sockaddrs in msg */
146     pid_t   rtm_pid;       /* identify sender */
147     int     rtm_seq;       /* for sender to identify action */
148     int     rtm_errno;     /* why failed */
149     int     rtm_use;       /* from rtenry */
150     u_long  rtm_inits;     /* which metrics we are initializing */
151     struct  rt_metrics rtm_rmx; /* metrics themselves */
152 };
-----route.h

```

Figure 19.16 rt\_msghdr structure.

```

-----if.h
235 struct if_msghdr {
236     u_short ifm_msglen;    /* to skip over non-understood messages */
237     u_char  ifm_version;  /* future binary compatability */
238     u_char  ifm_type;     /* message type */
239     int     ifm_addrs;    /* like rtm_addrs */
240     int     ifm_flags;    /* value of if_flags */
241     u_short ifm_index;    /* index for associated ifp */
242     struct  if_data ifm_data; /* statistics and other data about if */
243 };
-----if.h

```

Figure 19.17 if\_msghdr structure.

```

-----if.h
248 struct ifa_msghdr {
249     u_short ifam_msglen;  /* to skip over non-understood messages */
250     u_char  ifam_version; /* future binary compatability */
251     u_char  ifam_type;   /* message type */
252     int     ifam_addrs;  /* like rtm_addrs */
253     int     ifam_flags;  /* value of ifa_flags */
254     u_short ifam_index;  /* index for associated ifp */
255     int     ifam_metric; /* value of ifa_metric */
256 };
-----if.h

```

Figure 19.18 ifa\_msghdr structure.

Note that the first three members across the three different structures have the same data types and meanings.

The three variables `rtm_addrs`, `ifm_addrs`, and `ifam_addrs` are bitmasks defining which socket address structures follow the header. Figure 19.19 shows the constants used with these bitmasks.

R1  
R1  
R1  
R1  
R1  
R1  
R1

oute.h

\*/

NE \*/

\*/

Bitmask		Array index		Name in rtssock.c	Description
Constant	Value	Constant	Value		
RTA_DST	0x01	RTAX_DST	0	dst	destination socket address structure
RTA_GATEWAY	0x02	RTAX_GATEWAY	1	gate	gateway socket address structure
RTA_NETMASK	0x04	RTAX_NETMASK	2	netmask	netmask socket address structure
RTA_GENMASK	0x08	RTAX_GENMASK	3	genmask	cloning mask socket address structure
RTA_IFP	0x10	RTAX_IFP	4	ifpaddr	interface name socket address structure
RTA_IFA	0x20	RTAX_IFA	5	ifaaddr	interface address socket address structure
RTA_AUTHOR	0x40	RTAX_AUTHOR	6		socket address structure for author of redirect
RTA_BRD	0x80	RTAX_BRD	7	brdaddr	broadcast or point-to-point destination address
		RTAX_MAX	8		#elements in an rti_info[] array

Figure 19.19 Constants used to refer to members of rti\_info array.

route.h

if.h

\*/

\*/

if.h

if.h

\*/

The bitmask value is always the constant 1 left shifted by the number of bits specified by the array index. For example, 0x20 (RTA\_IFA) is 1 left shifted by five bits (RTAX\_IFA). We'll see this fact used in the code.

The socket address structures that are present always occur in order of increasing array index, one right after the other. For example, if the bitmask is 0x87, the first socket address structure contains the destination, followed by the gateway, followed by the network mask, followed by the broadcast address.

The array indexes in Figure 19.19 are used within the kernel to refer to its rt\_addrinfo structure, shown in Figure 19.20. This structure holds the same bitmask that we described, indicating which addresses are present, and pointers to those socket address structures.

```

199 struct rt_addrinfo {
200     int rti_addrs; /* bitmask, same as rtm_addrs */
201     struct sockaddr *rti_info[RTAX_MAX];
202 };
route.h
route.h

```

Figure 19.20 rt\_addrinfo structure: encode which addresses are present and pointers to them.

For example, if the RTA\_GATEWAY bit is set in the rti\_addrs member, then the member rti\_info[RTAX\_GATEWAY] is a pointer to a socket address structure containing the gateway's address. In the case of the Internet protocols, the socket address structure is a sockaddr\_in containing the gateway's IP address.

The fifth column in Figure 19.19 shows the names used for the corresponding members of an rti\_info array throughout the file rtssock.c. These definitions look like

```
#define dst info.rti_info[RTAX_DST]
```

We'll encounter these names in many of the source files later in this chapter. The RTAX\_AUTHOR element is not assigned a name because it is never passed from a process to the kernel.

We've already encountered this rt\_addrinfo structure twice: in rttalloc1 (Figure 19.2) and rtrredirect (Figure 19.14). Figure 19.21 shows the format of this

structure when built by `rtalloc1`, after a routing table lookup fails, when `rt_missmsg` is called.

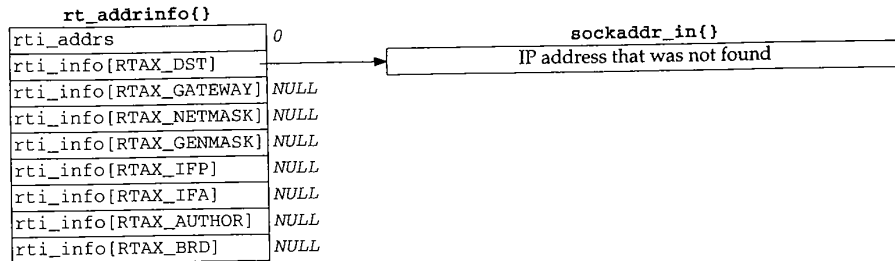

Figure 19.21 `rt_addrinfo` structure passed by `rtalloc1` to `rt_missmsg`.

All the unused pointers are null because the structure is set to 0 before it is used. Also note that the `rti_addr` member is not initialized with the appropriate bitmask because when this structure is used within the kernel, a null pointer in the `rti_info` array indicates a nonexistent socket address structure. The bitmask is needed only for messages between a process and the kernel.

Figure 19.22 shows the format of the structure built by `rtredirect` when it calls `rt_missmsg`.

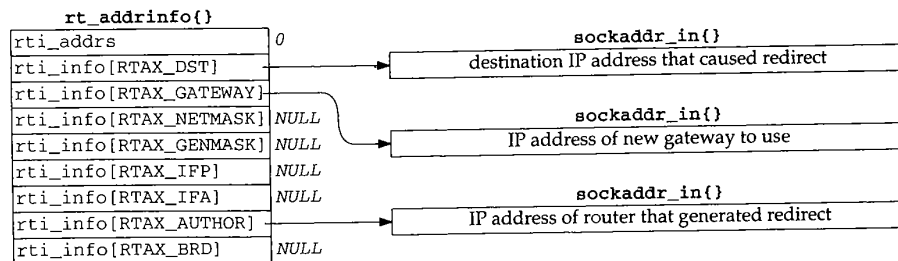

Figure 19.22 `rt_addrinfo` structure passed by `rtredirect` to `rt_missmsg`.

The following sections show how these structures are placed into the messages sent to a process.

Figure 19.23 shows the `route_cb` structure, which we'll encounter in the following sections. It contains four counters; one each for the IP, XNS, and OSI protocols, and an "any" counter. Each counter is the number of routing sockets currently in existence for that domain.

203-208 By keeping track of the number of routing socket listeners, the kernel avoids building a routing message and calling `raw_input` to send the message when there aren't any processes waiting for a message.

```

203 struct route_cb {
204     int    ip_count;        /* IP */
205     int    ns_count;       /* XNS */
206     int    iso_count;      /* ISO */
207     int    any_count;      /* sum of above three counters */
208 };

```

route.h

Figure 19.23 route\_cb structure: counters of routing socket listeners.

## 19.9 rt\_missmsg Function

The function `rt_missmsg`, shown in Figure 19.24, takes the structures shown in Figures 19.21 and 19.22, calls `rt_msg1` to build a corresponding variable-length message for a process in an mbuf chain, and then calls `raw_input` to pass the mbuf chain to all appropriate routing sockets.

```

516 void
517 rt_missmsg(type, rtinfo, flags, error)
518 int     type, flags, error;
519 struct rt_addrinfo *rtinfo;
520 {
521     struct rt_msghdr *rtm;
522     struct mbuf *m;
523     struct sockaddr *sa = rtinfo->rta_info[RTAX_DST];
524
525     if (route_cb.any_count == 0)
526         return;
527
528     m = rt_msg1(type, rtinfo);
529     if (m == 0)
530         return;
531
532     rtm = mtod(m, struct rt_msghdr *);
533     rtm->rtm_flags = RTF_DONE | flags;
534     rtm->rtm_errno = error;
535     rtm->rtm_addrs = rtinfo->rta_addrs;
536
537     route_proto.sp_protocol = sa ? sa->sa_family : 0;
538     raw_input(m, &route_proto, &route_src, &route_dst);
539 }

```

rtsock.c

Figure 19.24 `rt_missmsg` function.

516-525 If there aren't any routing socket listeners, the function returns immediately.

### Build message in mbuf chain

526-528 `rt_msg1` (Section 19.12) builds the appropriate message in an mbuf chain, and returns the pointer to the chain. Figure 19.25 shows an example of the resulting mbuf chain, using the `rt_addrinfo` structure from Figure 19.22. The information needs to be in an mbuf chain because `raw_input` calls `sbappendaddr` to append the mbuf chain to a socket's receive buffer.

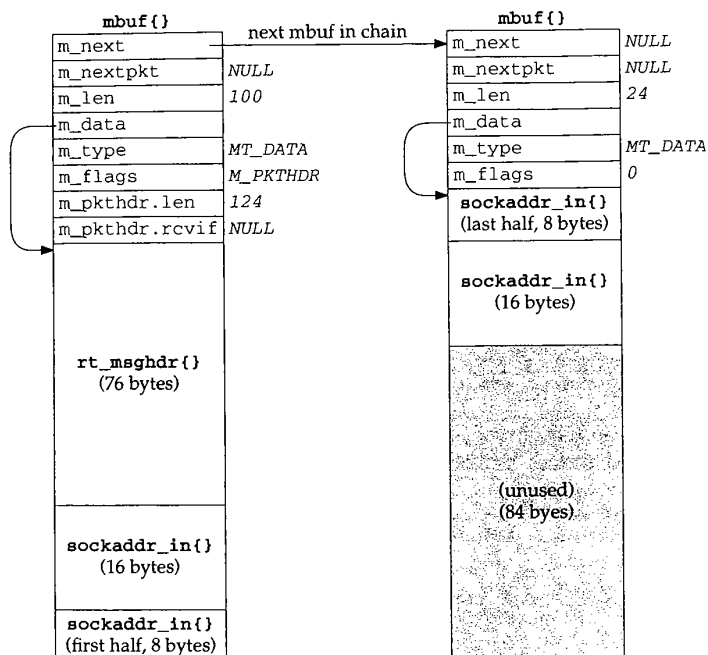
Figure 19.25 Mbuf chain built by `rt_msg1` corresponding to Figure 19.22.**Finish building message**

529-532 The two members `rtm_flags` and `rtm_errno` are set to the values passed by the caller. The `rtm_addrs` member is copied from the `rtn_addrs` value. We showed this value as 0 in Figures 19.21 and 19.22, but `rt_msg1` calculates and stores the appropriate bitmask, based on which pointers in the `rtn_info` array are nonnull.

**Set protocol of message, call `raw_input`**

533-534 The final three arguments to `raw_input` specify the protocol, source, and destination of the routing message. These three structures are initialized as

```
struct sockaddr route_dst = { 2, PF_ROUTE, };
struct sockaddr route_src = { 2, PF_ROUTE, };
struct sockproto route_proto = { PF_ROUTE, };
```

The first two structures are never modified by the kernel. The `sockproto` structure, shown in Figure 19.26, is one we haven't seen before.

```
128 struct sockproto {
129     u_short sp_family;          /* address family */
130     u_short sp_protocol;      /* protocol */
131 };
```

socket.h

socket.h

Figure 19.26 `sockproto` structure.

The family is never changed from its initial value of `PF_ROUTE`, but the protocol is set each time `raw_input` is called. When a process creates a routing socket by calling `socket`, the third argument (the protocol) specifies the protocol in which the process is interested. The caller of `raw_input` sets the `sp_protocol` member of the `route_proto` structure to the protocol of the routing message. In the case of `rt_missmsg`, it is set to the `sa_family` of the destination socket address structure (if specified by the caller), which in Figures 19.21 and 19.22 would be `AF_INET`.

### 19.10 `rt_ifmsg` Function

In Figure 4.30 we saw that `if_up` and `if_down` both call `rt_ifmsg`, shown in Figure 19.27, to generate a routing socket message when an interface goes up or down.

```

540 void
541 rt_ifmsg(ifp)
542 struct ifnet *ifp;
543 {
544     struct if_msghdr *ifm;
545     struct mbuf *m;
546     struct rt_addrinfo info;

547     if (route_cb.any_count == 0)
548         return;

549     bzero((caddr_t) & info, sizeof(info));
550     m = rt_msg1(RTM_IFINFO, &info);
551     if (m == 0)
552         return;

553     ifm = mtod(m, struct if_msghdr *);
554     ifm->ifm_index = ifp->if_index;
555     ifm->ifm_flags = ifp->if_flags;
556     ifm->ifm_data = ifp->if_data; /* structure assignment */
557     ifm->ifm_addrs = 0;

558     route_proto.sp_protocol = 0;
559     raw_input(m, &route_proto, &route_src, &route_dst);
560 }

```

*rtsock.c*

*rtsock.c*

Figure 19.27 `rt_ifmsg` function.

547-548 If there aren't any routing socket listeners, the function returns immediately.

#### Build message in mbuf chain

549-552 An `rt_addrinfo` structure is set to 0 and `rt_msg1` builds an appropriate message in an mbuf chain. Notice that all socket address pointers in the `rt_addrinfo` structure are null, so only the fixed-length `if_msghdr` structure becomes the routing message; there are no addresses.

**Finish building message**

553-557 The interface's index, flags, and `if_data` structure are copied into the message in the mbuf and the `ifm_addrs` bitmask is set to 0.

**Set protocol of message, call `raw_input`**

558-559 The protocol of the routing message is set to 0 because this message can apply to all protocol suites. It is a message about an interface, not about some specific destination. `raw_input` delivers the message to the appropriate listeners.

**19.11 `rt_newaddrmsg` Function**

In Figure 19.13 we saw that `rtinit` calls `rt_newaddrmsg` with a command of `RTM_ADD` or `RTM_DELETE` when an interface has an address added or deleted. Figure 19.28 shows the first half of the function.

```

569 void
570 rt_newaddrmsg(cmd, ifa, error, rt)
571 int cmd, error;
572 struct ifaddr *ifa;
573 struct rtentry *rt;
574 {
575     struct rt_addrinfo info;
576     struct sockaddr *sa;
577     int pass;
578     struct mbuf *m;
579     struct ifnet *ifp = ifa->ifa_ifp;
580
581     if (route_cb.any_count == 0)
582         return;
583
584     for (pass = 1; pass < 3; pass++) {
585         bzero((caddr_t) & info, sizeof(info));
586         if ((cmd == RTM_ADD && pass == 1) ||
587             (cmd == RTM_DELETE && pass == 2)) {
588             struct ifa_msghdr *ifam;
589             int ncmd = cmd == RTM_ADD ? RTM_NEWADDR : RTM_DELADDR;
590
591             ifaaddr = sa = ifa->ifa_addr;
592             ifpaddr = ifp->if_addrlist->ifa_addr;
593             netmask = ifa->ifa_netmask;
594             brdaddr = ifa->ifa_dstaddr;
595             if ((m = rt_msg1(ncmd, &info)) == NULL)
596                 continue;
597             ifam = mtod(m, struct ifa_msghdr *);
598             ifam->ifam_index = ifp->if_index;
599             ifam->ifam_metric = ifa->ifa_metric;
600             ifam->ifam_flags = ifa->ifa_flags;
601             ifam->ifam_addrs = info.rti_addrs;
602         }
603     }

```

Figure 19.28 `rt_newaddrmsg` function: first half: create `ifa_msghdr` message.



message in

ply to all  
destination.

mand of  
ted. Fig-

— rtsoc.c

OR;

— rtsoc.c

580-581 If there aren't any routing socket listeners, the function returns immediately.

#### Generate two routing messages

582 The for loop iterates twice because two messages are generated. If the command is RTM\_ADD, the first message is of type RTM\_NEWADDR and the second message is of type RTM\_DELETE. If the command is RTM\_DELETE, the first message is of type RTM\_NEWADDR and the second message is of type RTM\_DELADDR. The RTM\_NEWADDR and RTM\_DELADDR messages are built from an ifa\_msghdr structure, while the RTM\_ADD and RTM\_DELETE messages are built from an rt\_msghdr structure. The function generates two messages because one message provides information about the interface and the other about the addresses.

583 An rt\_addrinfo structure is set to 0.

#### Generate message with up to four addresses

588-591 Pointers to four socket address structures containing information about the interface address that has been added or deleted are stored in the rti\_info array. Recall from Figure 19.19 that ifaaddr, ifpaddr, netmask, and brdaddr reference elements in the rti\_info array in info. rt\_msg1 builds the appropriate message in an mbuf chain. Notice that sa is set to point to the ifa\_addr structure, and we'll see at the end of the function that the family of this socket address structure becomes the protocol of the routing message.

Remaining members of the ifa\_msghdr structure are filled in with the interface's index, metric, and flags, along with the bitmask set by rt\_msg1.

Figure 19.29 shows the second half of rt\_newaddrmsg, which creates an rt\_msghdr message with information about the routing table entry that was added or deleted.

#### Build message

600-609 Pointers to three socket address structures are stored in the rti\_info array: the rt\_mask, rt\_key, and rt\_gateway structures. sa is set to point to the destination address, and its family becomes the protocol of the routing message. rt\_msg1 builds the appropriate message in an mbuf chain.

Additional fields in the rt\_msghdr structure are filled in, including the bitmask set by rt\_msg1.

#### Set protocol of message, call raw\_input

616-619 The protocol of the routing message is set and raw\_input passes the message to the appropriate listeners. The function returns after two iterations through the loop.

```

rtsock.c
600     if ((cmd == RTM_ADD && pass == 2) ||
601         (cmd == RTM_DELETE && pass == 1)) {
602         struct rt_msghdr *rtm;

603         if (rt == 0)
604             continue;
605         netmask = rt_mask(rt);
606         dst = sa = rt_key(rt);
607         gate = rt->rt_gateway;
608         if ((m = rt_msg1(cmd, &info)) == NULL)
609             continue;
610         rtm = mtod(m, struct rt_msghdr *);
611         rtm->rtm_index = ifp->if_index;
612         rtm->rtm_flags |= rt->rt_flags;
613         rtm->rtm_errno = error;
614         rtm->rtm_addrs = info.rti_addrs;
615     }
616     route_proto.sp_protocol = sa ? sa->sa_family : 0;
617     raw_input(m, &route_proto, &route_src, &route_dst);
618 }
rtsock.c

```

Figure 19.29 `rt_newaddrmsg` function: second half, create `rt_msghdr` message.

## 19.12 `rt_msg1` Function

The functions described in the previous three sections each called `rt_msg1` to build the appropriate routing message. In Figure 19.25 we showed the mbuf chain that was built by `rt_msg1` from the `rt_msghdr` and `rt_addrinfo` structures in Figure 19.22. Figure 19.30 shows the function.

### Get mbuf and determine fixed size of message

399-422 An mbuf with a packet header is obtained and the length of the fixed-size message is stored in `len`. Two of the message types in Figure 18.9 use an `ifa_msghdr` structure, one uses an `if_msghdr` structure, and the remaining nine use an `rt_msghdr` structure.

### Verify structure fits in mbuf

423-424 The size of the fixed-length structure must fit entirely within the data portion of the packet header mbuf, because the mbuf pointer is cast to a structure pointer using `mtod` and the structure is then referenced through the pointer. The largest of the three structures is `if_msghdr`, which at 84 bytes is less than `MHLEN` (100).

### Initialize mbuf packet header and zero structure

425-428 The two fields in the packet header are initialized and the structure in the mbuf is set to 0.

ock.c

```

399 static struct mbuf *
400 rt_msg1(type, rtinfo)
401 int     type;
402 struct rt_addrinfo *rtinfo;
403 {
404     struct rt_msghdr *rtm;
405     struct mbuf *m;
406     int     i;
407     struct sockaddr *sa;
408     int     len, dlen;
409
410     m = m_gethdr(M_DONTWAIT, MT_DATA);
411     if (m == 0)
412         return (m);
413     switch (type) {
414     case RTM_DELADDR:
415     case RTM_NEWADDR:
416         len = sizeof(struct ifa_msghdr);
417         break;
418     case RTM_IFINFO:
419         len = sizeof(struct if_msghdr);
420         break;
421     default:
422         len = sizeof(struct rt_msghdr);
423     }
424     if (len > MHLEN)
425         panic("rt_msg1");
426     m->m_pkthdr.len = m->m_len = len;
427     m->m_pkthdr.rcvif = 0;
428     rtm = mtod(m, struct rt_msghdr *);
429     bzero((caddr_t) rtm, len);
430
431     for (i = 0; i < RTAX_MAX; i++) {
432         if ((sa = rtinfo->rta_info[i]) == NULL)
433             continue;
434         rtm->rta_addr |= (1 << i);
435         dlen = ROUNDUP(sa->sa_len);
436         m_copyback(m, len, dlen, (caddr_t) sa);
437         len += dlen;
438     }
439     if (m->m_pkthdr.len != len) {
440         m_freem(m);
441         return (NULL);
442     }
443     rtm->rtm_msglen = len;
444     rtm->rtm_version = RTM_VERSION;
445     rtm->rtm_type = type;
446     return (m);
447 }

```

rtsock.c

sock.c

l the  
built  
Fig-

sage  
ture,  
ture.

of the  
ntod  
truc-

uf is

rtsock.c

Figure 19.30 rt\_msg1 function: obtain and initialize mbuf.

**Copy socket address structures into mbuf chain**

429-436 The caller passes a pointer to an `rt_addrinfo` structure. The socket address structures corresponding to all the nonnull pointers in the `rti_info` are copied into the mbuf by `m_copyback`. The value 1 is left shifted by the `RTAX_xxx` index to generate the corresponding `RTA_xxx` bitmask (Figure 19.19), and each individual bitmask is logically ORed into the `rti_addrs` member, which the caller can store on return into the corresponding member of the message structure. The `ROUNDUP` macro rounds the size of each socket address structure up to the next multiple of 4 bytes.

437-440 If, when the loop terminates, the length in the mbuf packet header does not equal `len`, the function `m_copyback` wasn't able to obtain a required mbuf.

**Store length, version, and type**

441-445 The length, version, and message type are stored in the first three members of the message structure. Again, all three `xxx_msghdr` structures start with the same three members, so this code works with all three structures even though the pointer `rtm` is a pointer to an `rt_msghdr` structure.

**19.13 `rt_msg2` Function**

`rt_msg1` constructs a routing message in an mbuf chain, and the three functions that called it then called `raw_input` to append the mbuf chain to one or more socket's receive buffer. `rt_msg2` is different—it builds a routing message in a memory buffer, not an mbuf chain, and has as an argument a pointer to a `walkarg` structure that is used when `rt_msg2` is called by the two functions that handle the `sysctl` system call for the routing domain. `rt_msg2` is called in two different scenarios:

1. from `route_output` to process the `RTM_GET` command, and
2. from `sysctl_dumpentry` and `sysctl_iflist` to process a `sysctl` system call.

Before looking at `rt_msg2`, Figure 19.31 shows the `walkarg` structure that is used in scenario 2. We go through all these members as we encounter them.

```

41 struct walkarg {
42     int     w_op;                /* NET_RT_xxx */
43     int     w_arg;              /* RTF_xxx for FLAGS, if_index for IFLIST */
44     int     w_given;           /* size of process' buffer */
45     int     w_needed;         /* #bytes actually needed (at end) */
46     int     w_tmemsiz;        /* size of buffer pointed to by w_tmemb */
47     caddr_t w_where;          /* ptr to process' buffer (maybe null) */
48     caddr_t w_tmemb;          /* ptr to our malloc'ed buffer */
49 };

```

— *rtsock.c*

— *rtsock.c*

Figure 19.31 `walkarg` structure: used with the `sysctl` system call in the routing domain.

Figure 19.32 shows the first half of the `rt_msg2` function. This portion is similar to the first half of `rt_msg1`.

```

446 static int
447 rt_msg2(type, rtinfo, cp, w)
448 int type;
449 struct rt_addrinfo *rtinfo;
450 caddr_t cp;
451 struct walkarg *w;
452 {
453     int i;
454     int len, dlen, second_time = 0;
455     caddr_t cp0;
456     rtinfo->rta_addrs = 0;
457     again:
458     switch (type) {
459     case RTM_DELADDR:
460     case RTM_NEWADDR:
461         len = sizeof(struct ifa_msghdr);
462         break;
463     case RTM_IFINFO:
464         len = sizeof(struct if_msghdr);
465         break;
466     default:
467         len = sizeof(struct rt_msghdr);
468     }
469     if (cp0 = cp)
470         cp += len;
471     for (i = 0; i < RTAX_MAX; i++) {
472         struct sockaddr *sa;
473         if ((sa = rtinfo->rta_info[i]) == 0)
474             continue;
475         rtinfo->rta_addrs |= (1 << i);
476         dlen = ROUNDUP(sa->sa_len);
477         if (cp) {
478             bcopy((caddr_t) sa, cp, (unsigned) dlen);
479             cp += dlen;
480         }
481         len += dlen;
482     }

```

Figure 19.32 rt\_msg2 function: copy socket address structures.

446-455 Since this function stores the resulting message in a memory buffer, the caller specifies the start of that buffer in the `cp` argument. It is the caller's responsibility to ensure that the buffer is large enough for the message that is generated. To help the caller determine this size, if the `cp` argument is null, `rt_msg2` doesn't store anything but processes the input and returns the total number of bytes required to hold the result. We'll see that `route_output` uses this feature and calls this function twice: first to determine the size and then to store the result, after allocating a buffer of the correct size. When `rt_msg2` is called by `route_output`, the final argument is null. This final argument is nonnull when called as part of the `sysctl` system call processing.

**Determine size of structure**

458-470 The size of the fixed-length message structure is set based on the message type. If the `cp` pointer is nonnull, it is incremented by this size.

**Copy socket address structures**

471-482 The `for` loop goes through the `rti_info` array, and for each element that is a non-null pointer it sets the appropriate bit in the `rti_addrs` bitmask, copies the socket address structure (if `cp` is nonnull), and updates the length.

Figure 19.33 shows the second half of `rt_msg2`, most of which handles the optional `walkarg` structure.

```

483     if (cp == 0 && w != NULL && !second_time) {
484         struct walkarg *rw = w;
485         rw->w_needed += len;
486         if (rw->w_needed <= 0 && rw->w_where) {
487             if (rw->w_tmemsiz < len) {
488                 if (rw->w_tmem)
489                     free(rw->w_tmem, M_RTABLE);
490                 if (rw->w_tmem = (caddr_t)
491                     malloc(len, M_RTABLE, M_NOWAIT))
492                     rw->w_tmemsiz = len;
493             }
494             if (rw->w_tmem) {
495                 cp = rw->w_tmem;
496                 second_time = 1;
497                 goto again;
498             } else
499                 rw->w_where = 0;
500         }
501     }
502     if (cp) {
503         struct rt_msghdr *rtm = (struct rt_msghdr *) cp0;
504         rtm->rtm_version = RTM_VERSION;
505         rtm->rtm_type = type;
506         rtm->rtm_msglen = len;
507     }
508     return (len);
509 }

```

*rtsock.c*

Figure 19.33 `rt_msg2` function: handle optional `walkarg` argument.

483-484 This `if` statement is true only when a pointer to a `walkarg` structure was passed and this is the first loop through the function. The variable `second_time` was initialized to 0 but can be set to 1 within this `if` statement, and a jump made back to the label `again` in Figure 19.32. The test for `cp` being a null pointer is superfluous since whenever the `w` pointer is nonnull, the `cp` pointer is null, and vice versa.

**Check if data to be stored**

485-486 `w_needed` is incremented by the size of the message. This variable is initialized to 0 minus the size of the user's buffer to the `sysctl` function. For example, if the buffer

2. If

non-  
cket

onal

sock.c

tssock.c

passed  
initial-  
e label  
when-

zed to  
buffer

size is 500 bytes, `w_needed` is initialized to `-500`. As long as it remains negative, there is room in the buffer. `w_where` is a pointer to the buffer in the calling process. It is null if the process doesn't want the result—the process just wants `sysctl` to return the size of the result, so the process can allocate a buffer and call `sysctl` again. `rt_msg2` doesn't copy the data back to the process—that is up to the caller—but if the `w_where` pointer is null, there's no need for `rt_msg2` to `malloc` a buffer to hold the result and loop back through the function again, storing the result in this buffer. There are really five different scenarios that this function handles, summarized in Figure 19.34.

called from	cp	w	w.w_where	second_time	Description
route_output	null	null			wants return length
	nonnull	null			wants result
sysctl_rtable	null	nonnull	null	0	process wants return length
	null	nonnull	nonnull	0	first time around to calculate length
	nonnull	nonnull	nonnull	1	second time around to store result

Figure 19.34 Summary of different scenarios for `rt_msg2`.

**Allocate buffer first time or if message length increases**

487-493 `w_tmemszie` is the size of the buffer pointed to by `w_tmem`. It is initialized to 0 by `sysctl_rtable`, so the first time `rt_msg2` is called for a given `sysctl` request, the buffer must be allocated. Also, if the size of the result increases, the existing buffer must be released and a new (larger) buffer allocated.

**Go around again and store result**

494-499 If `w_tmem` is nonnull, a buffer already exists or one was just allocated. `cp` is set to point to this buffer, `second_time` is set to 1, and a jump is made to `again`. The `if` statement at the beginning of this figure won't be true during this second pass, since `second_time` is now 1. If `w_tmem` is null, the call to `malloc` failed, so the pointer to the buffer in the process is set to null, preventing anything from being returned.

**Store length, version, and type**

502-509 If `cp` is nonnull, the first three elements of the message header are stored. The function returns the length of the message.

**19.14 sysctl\_rtable Function**

This function handles the `sysctl` system call on a routing socket. It is called by `net_sysctl` as shown in Figure 18.11.

Before going through the source code, Figure 19.35 shows the typical use of this system call with respect to the routing table. This example is from the `arp` program.

The first three elements in the `mib` array cause the kernel to call `sysctl_rtable` to process the remaining elements.

```

int     mib[6];
size_t  needed;
char    *buf, *lim, *next;
struct  rt_msghdr *rtm;

mib[0] = CTL_NET;
mib[1] = PF_ROUTE;
mib[2] = 0;
mib[3] = AF_INET;      /* address family; can be 0 */
mib[4] = NET_RT_FLAGS; /* operation */
mib[5] = RTF_LLINFO;  /* flags; can be 0 */

if (sysctl(mib, 6, NULL, &needed, NULL, 0) < 0)
    quit("sysctl error, estimate");

if ( (buf = malloc(needed)) == NULL)
    quit("malloc");

if (sysctl(mib, 6, buf, &needed, NULL, 0) < 0)
    quit("sysctl error, retrieval");

lim = buf + needed;
for (next = buf; next < lim; next += rtm->rtm_msglen) {
    rtm = (struct rt_msghdr *)next;
    ... /* do whatever */
}

```

Figure 19.35 Example of sysctl with routing table.

mib[4] specifies the operation. Three operations are supported.

1. NET\_RT\_DUMP: return the routing table corresponding to the address family specified by mib[3]. If the address family is 0, all routing tables are returned.

An RTM\_GET routing message is returned for each routing table entry containing two, three, or four socket address structures per message: those addresses pointed to by rt\_key, rt\_gateway, rt\_netmask, and rt\_genmask. The final two pointers might be null.

2. NET\_RT\_FLAGS: the same as the previous command except mib[5] specifies an RTF\_xxx flag (Figure 18.25), and only entries with this flag set are returned.
3. NET\_RT\_IFLIST: return information on all the configured interfaces. If the mib[5] value is nonzero it specifies an interface index and only the interface with the corresponding if\_index is returned. Otherwise all interfaces on the ifnet linked list are returned.

For each interface one RTM\_IFINFO message is returned, with information about the interface itself, followed by one RTM\_NEWADDR message for each ifaddr structure on the interface's if\_addrlist linked list. If the mib[3] value is nonzero, RTM\_NEWADDR messages are returned for only the addresses



with an address family that matches the `mib[3]` value. Otherwise `mib[3]` is 0 and information on all addresses is returned.

This operation is intended to replace the `SIOCGIFCONF` ioctl (Figure 4.26).

One problem with this system call is that the amount of information returned can vary, depending on the number of routing table entries or the number of interfaces. Therefore the first call to `sysctl` typically specifies a null pointer as the third argument, which means: don't return any data, just return the number of bytes of return information. As we see in Figure 19.35, the process then calls `malloc`, followed by `sysctl` to fetch the information. This second call to `sysctl` again returns the number of bytes through the fourth argument (which might have changed since the previous call), and this value provides the pointer `lim` that points just beyond the final byte of data that was returned. The process then steps through the routing messages in the buffer, using the `rtm_msglen` member to step to the next message.

Figure 19.36 shows the values for these six `mib` variables that various Net/3 programs specify to access the routing table and interface list.

mib[]	arp	route	netstat	routed	gated	rwhod
0	CTL_NET	CTL_NET	CTL_NET	CTL_NET	CTL_NET	CTL_NET
1	PF_ROUTE	PF_ROUTE	PF_ROUTE	PF_ROUTE	PF_ROUTE	PF_ROUTE
2	0	0	0	0	0	0
3	AF_INET	0	0	AF_INET	0	AF_INET
4	NET_RT_FLAGS	NET_RT_DUMP	NET_RT_DUMP	NET_RT_IFLIST	NET_RT_IFLIST	NET_RT_IFLIST
5	RTF_LLINFO	0	0	0	0	0

Figure 19.36 Examples of programs that call `sysctl` to obtain routing table and interface list.

The first three programs fetch entries from the routing table and the last three fetch the interface list. The `routed` program supports only the Internet routing protocols, so it specifies a `mib[3]` value of `AF_INET`, while `gated` supports other protocols, so its value for `mib[3]` is 0.

Figure 19.37 shows the organization of the three `sysctl_xxx` functions that we cover in the following sections.

Figure 19.38 shows the `sysctl_rtable` function.

**Validate arguments**

705-719 The new argument is used when the process is calling `sysctl` to set the value of a variable, which isn't supported with the routing tables. Therefore this argument must be a null pointer.

720-721 `namelen` must be 3 because at this point in the processing of the system call, three elements in the name array remain: `name[0]`, the address family (what the process specifies as `mib[3]`); `name[1]`, the operation (`mib[4]`); and `name[2]`, the flags (`mib[5]`).

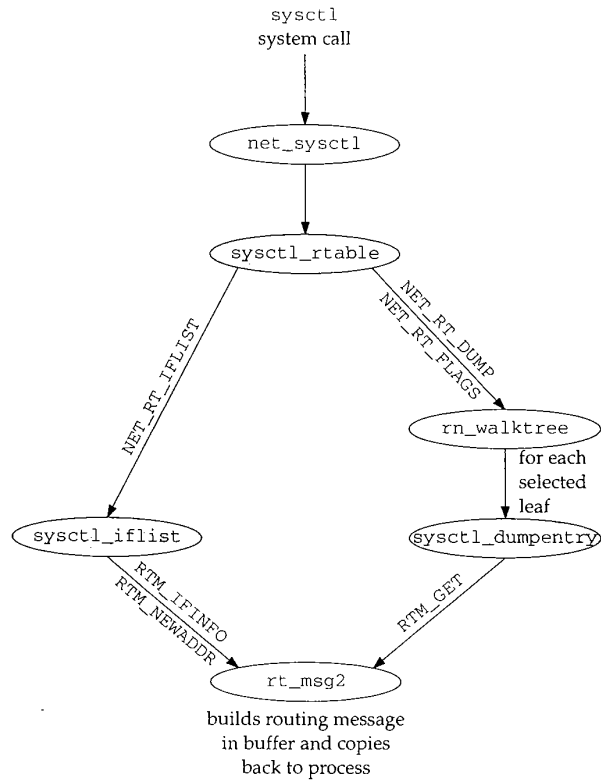

Figure 19.37 Functions that support the `sysctl` system call for routing sockets.

```

705 int
706 sysctl_rtable(name, namelen, where, given, new, newlen)
707 int *name;
708 int namelen;
709 caddr_t where;
710 size_t *given;
711 caddr_t *new;
712 size_t newlen;
713 {
714     struct radix_node_head *rn;
715     int i, s, error = EINVAL;
716     u_char af;
717     struct walkarg w;
718
719     if (new)
720         return (EPERM);
721 }

```

*rtsock.c*

```

720     if (namelen != 3)
721         return (EINVAL);
722     af = name[0];
723     Bzero(&w, sizeof(w));
724     w.w_where = where;
725     w.w_given = *given;
726     w.w_needed = 0 - w.w_given;
727     w.w_op = name[1];
728     w.w_arg = name[2];

729     s = splnet();
730     switch (w.w_op) {

731     case NET_RT_DUMP:
732     case NET_RT_FLAGS:
733         for (i = 1; i <= AF_MAX; i++)
734             if ((rnh = rt_tables[i]) && (af == 0 || af == i) &&
735                 (error = rnh->rnh_walktree(rnh,
736                                         sysctl_dumppentry, &w)))
737                 break;
738         break;

739     case NET_RT_IPLIST:
740         error = sysctl_iflist(af, &w);
741     }
742     splx(s);
743     if (w.w_tmem)
744         free(w.w_tmem, M_RTABLE);
745     w.w_needed += w.w_given;
746     if (where) {
747         *given = w.w_where - where;
748         if (*given < w.w_needed)
749             return (ENOMEM);
750     } else {
751         *given = (11 * w.w_needed) / 10;
752     }
753     return (error);
754 }

```

rtsock.c

— rtsock.c

Figure 19.38 sysctl\_rtable function: process sysctl system call requests.

**Initialize walkarg structure**

723-728 A walkarg structure (Figure 19.31) is set to 0 and the following members are initialized: `w_where` is the address in the calling process of the buffer for the results (this can be a null pointer, as we mentioned); `w_given` is the size of the buffer in bytes (this is meaningless on input if `w_where` is a null pointer, but it must be set on return to the amount of data that would have been returned); `w_needed` is set to the negative of the buffer size; `w_op` is the operation (the `NET_RT_XXX` value); and `w_arg` is the flags value.

**Dump routing table**

731-738 The `NET_RT_DUMP` and `NET_RT_FLAGS` operations are handled the same way: a loop is made through all the routing tables (the `rt_tables` array), and if the routing

table is in use and either the address family argument was 0 or the address family argument matches the family of this routing table, the `rn_walktree` function is called to process the entire routing table. In Figure 18.17 we show that this function is normally `rn_walktree`. The second argument to this function is the address of another function that is called for each leaf of the routing tree (`sysctl_dumpentry`). The third argument is just a pointer to anything that `rn_walktree` passes to the `sysctl_dumpentry` function. This argument is a pointer to the `walkarg` structure that contains all the information about this `sysctl` call.

#### Return interface list

739-740 The `NET_RT_IFLIST` operation calls the function `sysctl_iflist`, which goes through all the `ifnet` structures.

#### Release buffer

743-744 If a buffer was allocated by `rt_msg2` to contain a routing message, it is now released.

#### Update `w_needed`

745 The size of each message was added to `w_needed` by `rt_msg2`. Since this variable was initialized to the negative of `w_given`, its value can now be expressed as

$$w\_needed = 0 - w\_given + totalbytes$$

where `totalbytes` is the sum of all the message lengths added by `rt_msg2`. By adding the value of `w_given` back into `w_needed`, we get

$$\begin{aligned} w\_needed &= 0 - w\_given + totalbytes + w\_given \\ &= totalbytes \end{aligned}$$

the total number of bytes. Since the two values of `w_given` in this equation end up canceling each other, when the process specifies `w_where` as a null pointer it need not initialize the value of `w_given`. Indeed, we see in Figure 19.35 that the variable `needed` was not initialized.

#### Return actual size of message

746-749 If `where` is nonnull, the number of bytes stored in the buffer is returned through the `given` pointer. If this value is less than the size of the buffer specified by the process, an error is returned because the return information has been truncated.

#### Return estimated size of message

750-752 When the `where` pointer is null, the process just wants the total number of bytes returned. A 10% fudge factor is added to the size, in case the size of the desired tables increases between this call to `sysctl` and the next.

## 19.15 `sysctl_dumpentry` Function

In the previous section we described how this function is called by `rn_walktree`, which in turn is called by `sysctl_rtable`. Figure 19.39 shows the function.

rgu-  
d to  
ally  
tion  
rgu-  
the  
:ture  
  
goes  
  
now  
  
iable  
  
.. By  
  
id up  
d not  
riable

```

623 int
624 sysctl_dumpentry(rn, w)
625 struct radix_node *rn;
626 struct walkarg *w;
627 {
628     struct rtentry *rt = (struct rtentry *) rn;
629     int error = 0, size;
630     struct rt_addrinfo info;
631
632     if (w->w_op == NET_RT_FLAGS && !(rt->rt_flags & w->w_arg))
633         return 0;
634     bzero((caddr_t) & info, sizeof(info));
635     dst = rt_key(rt);
636     gate = rt->rt_gateway;
637     netmask = rt_mask(rt);
638     genmask = rt->rt_genmask;
639     size = rt_msg2(RTM_GET, &info, 0, w);
640     if (w->w_where && w->w_tmem) {
641         struct rt_msghdr *rtm = (struct rt_msghdr *) w->w_tmem;
642
643         rtm->rtm_flags = rt->rt_flags;
644         rtm->rtm_use = rt->rt_use;
645         rtm->rtm_rmx = rt->rt_rmx;
646         rtm->rtm_index = rt->rt_ifp->if_index;
647         rtm->rtm_errno = rtm->rtm_pid = rtm->rtm_seq = 0;
648         rtm->rtm_addrs = info.rti_addrs;
649         if (error = copyout((caddr_t) rtm, w->w_where, size))
650             w->w_where = NULL;
651         else
652             w->w_where += size;
653     }
654     return (error);
655 }

```

Figure 19.39 sysctl\_dumpentry function: process one routing table entry.

623-630 Each time this function is called, its first argument points to a radix\_node structure, which is also a pointer to a rtentry structure. The second argument points to the walkarg structure that was initialized by sysctl\_rtable.

#### Check flags of routing table entry

631-632 If the process specified a flag value (mib[5]), this entry is skipped if the rt\_flags member doesn't have the desired flag set. We see in Figure 19.36 that the arp program uses this to select only those entries with the RTF\_LLINFO flag set, since these are the entries of interest to ARP.

#### Form routing message

633-638 The following four pointers in the rti\_info array are copied from the routing table entry: dst, gate, netmask, and genmask. The first two are always nonnull, but the other two can be null. rt\_msg2 forms an RTM\_GET message.

bytes  
tables  
  
tree,

**Copy message back to process**

639-651 If the process wants the message returned and a buffer was allocated by `rt_msg2`, the remainder of the routing message is formed in the buffer pointed to by `w_tmem` and `copyout` copies the message back to the process. If the copy was successful, `w_where` is incremented by the number of bytes copied.

**19.16 sysctl\_iflist Function**

This function, shown in Figure 19.40, is called directly by `sysctl_rtable` to return the interface list to the process.

```

654 int
655 sysctl_iflist(af, w)
656 int    af;
657 struct walkarg *w;
658 {
659     struct ifnet *ifp;
660     struct ifaddr *ifa;
661     struct rt_addrinfo info;
662     int    len, error = 0;

663     bzero((caddr_t) & info, sizeof(info));
664     for (ifp = ifnet; ifp; ifp = ifp->if_next) {
665         if (w->w_arg && w->w_arg != ifp->if_index)
666             continue;
667         ifa = ifp->if_addrlist;
668         ifpaddr = ifa->ifa_addr;
669         len = rt_msg2(RTM_IFINFO, &info, (caddr_t) 0, w);
670         ifpaddr = 0;
671         if (w->w_where && w->w_tmem) {
672             struct if_msghdr *ifm;

673             ifm = (struct if_msghdr *) w->w_tmem;
674             ifm->ifm_index = ifp->if_index;
675             ifm->ifm_flags = ifp->if_flags;
676             ifm->ifm_data = ifp->if_data;
677             ifm->ifm_addrs = info.rti_addrs;
678             if (error = copyout((caddr_t) ifm, w->w_where, len))
679                 return (error);
680             w->w_where += len;
681         }
682         while (ifa = ifa->ifa_next) {
683             if (af && af != ifa->ifa_addr->sa_family)
684                 continue;
685             ifaaddr = ifa->ifa_addr;
686             netmask = ifa->ifa_netmask;
687             brdaddr = ifa->ifa_dstaddr;
688             len = rt_msg2(RTM_NEWADDR, &info, 0, w);
689             if (w->w_where && w->w_tmem) {
690                 struct ifa_msghdr *ifam;

```

*rtsock.c*

rt\_msg2,  
\_tmem and  
\_w\_where

return the

— rtsock.c

```

691         ifam = (struct ifa_msghdr *) w->w_tmem;
692         ifam->ifam_index = ifa->ifa_ifp->if_index;
693         ifam->ifam_flags = ifa->ifa_flags;
694         ifam->ifam_metric = ifa->ifa_metric;
695         ifam->ifam_addrs = info.rti_addrs;
696         if (error = copyout(w->w_tmem, w->w_where, len))
697             return (error);
698         w->w_where += len;
699     }
700 }
701     ifaaddr = netmask = brdaddr = 0;
702 }
703 return (0);
704 }

```

rtsock.c

**Figure 19.40** sysctl\_iflist function: return list of interfaces and their addresses.

This function is a for loop that iterates through each interface starting with the one pointed to by `ifnet`. Then a while loop proceeds through the linked list of `ifa` structures for each interface. An `RTM_IFINFO` routing message is generated for each interface and an `RTM_NEWADDR` message for each address.

#### Check interface index

654-666 The process can specify a nonzero flags argument (`mib[5]` in Figure 19.36) to select only the interface with a matching `if_index` value.

#### Build routing message

667-670 The only socket address structure returned with the `RTM_IFINFO` message is `ifpaddr`. The message is built by `rt_msg2`. The pointer `ifpaddr` in the `info` structure is then set to 0, since the same `info` structure is used for generating the subsequent `RTM_NEWADDR` messages.

#### Copy message back to process

671-681 If the process wants the message returned, the remainder of the `ifa_msghdr` structure is filled in, `copyout` copies the buffer to the process, and `w_where` is incremented.

#### Iterate through address structures, check address family

682-684 Each `ifa` structure for the interface is processed and the process can specify a nonzero address family (`mib[3]` in Figure 19.36) to select only the interface addresses of the given family.

#### Build routing message

685-688 Up to three socket address structures are returned in each `RTM_NEWADDR` message: `ifaaddr`, `netmask`, and `brdaddr`. The message is built by `rt_msg2`.

#### Copy message back to process

689-699 If the process wants the message returned, the remainder of the `ifa_msghdr` structure is filled in, `copyout` copies the buffer to the process, and `w_where` is incremented.

701 These three pointers in the `info` array are set to 0, since the same array is used for the next interface message.

## 19.17 Summary

Routing messages all have the same format—a fixed-length structure followed by a variable number of socket address structures. There are three different types of messages, each corresponding to a different fixed-length structure, and the first three elements of each structure identify the length, version, and type of message. A bitmask in each structure identifies which socket address structures follow the fixed-length structure.

These messages are passed between a process and the kernel in two different ways. Messages can be passed in either direction, one message per read or write, across a routing socket. This allows a superuser process complete read and write access to the kernel's routing tables. This is how routing daemons such as `routed` and `gated` implement their desired routing policy.

Alternatively any process can read the contents of the kernel's routing tables using the `sysctl` system call. This does not involve a routing socket and does not require special privileges. The entire result, normally consisting of many routing messages, is returned as part of the system call. Since the process does not know the size of the result, a method is provided for the system call to return this size without returning the actual result.

## Exercises

- 19.1 What is the difference in the `RTF_DYNAMIC` and `RTF_MODIFIED` flags? Can both be set for a given routing table entry?
- 19.2 What happens when the default route is entered with a command of the form  

```
bsd1 $ route add default -cloning -genmask 255.255.255.255 sun
```
- 19.3 Estimate the space required by `sysctl` to dump a routing table that contains 15 ARP entries and 20 routes.



19

a  
s-  
le-  
in  
ic-

ys.  
it-  
er-  
ed

ng  
ire  
. is  
he  
he

for

VRP

# 20

## Routing Sockets

### 20.1 Introduction

A process sends and receives the routing messages described in the previous chapter by using a socket in the *routing domain*. The `socket` system call is issued specifying a family of `PF_ROUTE` and a socket type of `SOCK_RAW`.

The process can then send five routing messages to the kernel:

1. `RTM_ADD`: add a new route.
2. `RTM_DELETE`: delete an existing route.
3. `RTM_GET`: fetch all the information about a route.
4. `RTM_CHANGE`: change the gateway, interface, or metrics of an existing route.
5. `RTM_LOCK`: specify which metrics the kernel should not modify.

Additionally, the process can receive any of the other seven types of routing messages that are generated by the kernel when some event, such as interface down, redirect received, etc., occurs.

This chapter looks at the routing domain, the routing control blocks that are created for each routing socket, the function that handles messages from a process (`route_output`), the function that sends routing messages to one or more processes (`raw_input`), and the various functions that support all the socket operations on a routing socket.

## 20.2 routedomain and protosw Structures

Before describing the routing socket functions, we need to discuss additional details about the routing domain; the SOCK\_RAW protocol supported in the routing domain; and routing control blocks, one of which is associated with each routing socket.

Figure 20.1 lists the domain structure for the PF\_ROUTE domain, named `routedomain`.

Member	Value	Description
<code>dom_family</code>	<code>PF_ROUTE</code>	protocol family for domain
<code>dom_name</code>	<code>route</code>	name
<code>dom_init</code>	<code>route_init</code>	domain initialization, Figure 18.30
<code>dom_externalize</code>	<code>0</code>	not used in routing domain
<code>dom_dispose</code>	<code>0</code>	not used in routing domain
<code>dom_protosw</code>	<code>routesw</code>	protocol switch structure, Figure 20.2
<code>dom_protoswNPROTOSW</code>		pointer past end of protocol switch structure
<code>dom_next</code>		filled in by <code>domaininit</code> , Figure 7.15
<code>dom_rtattach</code>	<code>0</code>	not used in routing domain
<code>dom_rtoffset</code>	<code>0</code>	not used in routing domain
<code>dom_maxrtkey</code>	<code>0</code>	not used in routing domain

Figure 20.1 `routedomain` structure.

Unlike the Internet domain, which supports multiple protocols (TCP, UDP, ICMP, etc.), only one protocol (of type SOCK\_RAW) is supported in the routing domain. Figure 20.2 lists the protocol switch entry for the PF\_ROUTE domain.

Member	<code>routesw[0]</code>	Description
<code>pr_type</code>	<code>SOCK_RAW</code>	raw socket
<code>pr_domain</code>	<code>&amp;routedomain</code>	part of the routing domain
<code>pr_protocol</code>	<code>0</code>	
<code>pr_flags</code>	<code>PR_ATOMIC PR_ADDR</code>	socket layer flags, not used by protocol processing
<code>pr_input</code>	<code>raw_input</code>	this entry not used; <code>raw_input</code> called directly
<code>pr_output</code>	<code>route_output</code>	called for PRU_SEND requests
<code>pr_ctlinput</code>	<code>raw_ctlinput</code>	control input function
<code>pr_ctloutput</code>	<code>0</code>	not used
<code>pr_usrreq</code>	<code>route_usrreq</code>	respond to communication requests from a process
<code>pr_init</code>	<code>raw_init</code>	initialization
<code>pr_fasttimo</code>	<code>0</code>	not used
<code>pr_slowtimo</code>	<code>0</code>	not used
<code>pr_drain</code>	<code>0</code>	not used
<code>pr_sysctl</code>	<code>sysctl_rtable</code>	for <code>sysctl(8)</code> system call

Figure 20.2 The routing protocol `protosw` structure.

## 20.3 Routing Control Blocks

Each time a routing socket is created with a call of the form

```
socket(PF_ROUTE, SOCK_RAW, protocol);
```

the corresponding PRU\_ATTACH request to the protocol's user-request function (`route_usrreq`) allocates a routing control block and links it to the socket structure. The *protocol* can restrict the messages sent to the process on this socket to one particular family. If a *protocol* of `AF_INET` is specified, for example, only routing messages containing Internet addresses will be sent to the process. A *protocol* of 0 causes all routing messages from the kernel to be sent on the socket.

Recall that we call these structures *routing control blocks*, not *raw control blocks*, to avoid confusion with the raw IP control blocks in Chapter 32.

Figure 20.3 shows the definition of the `rawcb` structure.

```

-----raw_cb.h
39 struct rawcb {
40     struct rawcb *rcb_next;    /* doubly linked list */
41     struct rawcb *rcb_prev;
42     struct socket *rcb_socket; /* back pointer to socket */
43     struct sockaddr *rcb_faddr; /* destination address */
44     struct sockaddr *rcb_laddr; /* socket's address */
45     struct sockproto rcb_proto; /* protocol family, protocol */
46 };
47 #define sotorawcb(so) ((struct rawcb *) (so)->so_pcb)
-----raw_cb.h

```

Figure 20.3 rawcb structure.

Additionally, a global of the same name, `rawcb`, is allocated as the head of the doubly linked list. Figure 20.4 shows the arrangement.

39-47 We showed the `sockproto` structure in Figure 19.26. Its `sp_family` member is set to `PF_ROUTE` and its `sp_protocol` member is set to the third argument to the socket system call. The `rcb_faddr` member is permanently set to point to `route_src`, which we described with Figure 19.26. `rcb_laddr` is always a null pointer.

## 20.4 raw\_init Function

The `raw_init` function, shown in Figure 20.5, is the protocol initialization function in the `protosw` structure in Figure 20.2. We described the entire initialization of the routing domain with Figure 18.29.

38-42 The function initializes the doubly linked list of routing control blocks by setting the next and previous pointers of the head structure to point to itself.

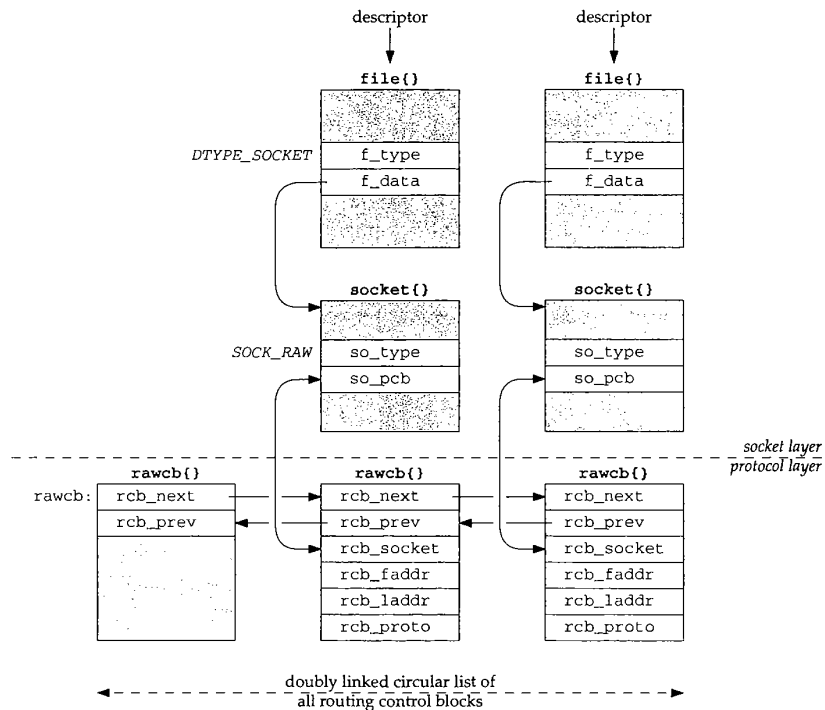

Figure 20.4 Relationship of raw protocol control blocks to other data structures.

```

38 void
39 raw_init()
40 {
41     rawcb.rcb_next = rawcb.rcb_prev = &rawcb;
42 }

```

*raw\_usrreq.c*

*raw\_usrreq.c*

Figure 20.5 `raw_init` function: initialize doubly linked list of routing control blocks.

## 20.5 route\_output Function

As we showed in Figure 18.11, `route_output` is called when the `PRU_SEND` request is issued to the protocol's user-request function, which is the result of a write operation by a process to a routing socket. In Figure 18.9 we indicated that five different types of routing messages are accepted by the kernel from a process.

Since this function is invoked as a result of a write by a process, the data from the process (the routing message to process) is in an mbuf chain from `sosend`. Figure 20.6

shows an overview of the processing steps, assuming the process sends an RTM\_ADD command, specifying three addresses: the destination, its gateway, and a network mask (hence this is a network route, not a host route).

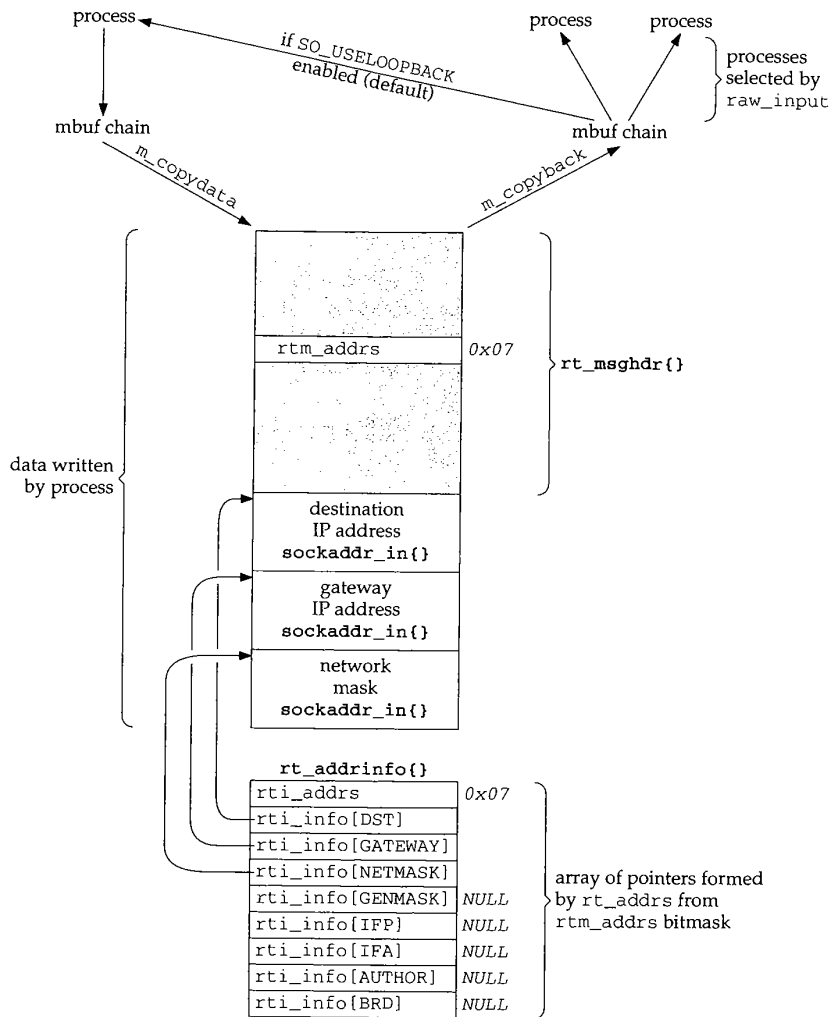

Figure 20.6 Example processing of an RTM\_ADD command from a process.

There are numerous points to note in this figure, most of which we'll cover as we proceed through the source code for route\_output. Also note that, to save space, we omit the RTAX\_ prefix for each array index in the rt\_addrinfo structure.

- The process specifies which socket address structures follow the fixed-length `rt_msghdr` structure by setting the bitmask `rtm_addrs`. We show a bitmask of `0x07`, which corresponds to a destination address, a gateway address, and a network mask (Figure 19.19). The `RTM_ADD` command requires the first two; the third is optional. Another optional address, the `genmask` specifies the mask to be used for generating cloned routes.
- The `write` system call (the `sosend` function) copies the buffer from the process into an mbuf chain in the kernel.
- `m_copydata` copies the mbuf chain into a buffer that `route_output` obtains using `m_malloc`. It is easier to access all the information in the structure and the socket address structures that follow when stored in a single contiguous buffer than it is when stored in an mbuf chain.
- The function `rt_xaddrs` is called by `route_output` to take the bitmask and build the `rt_addrinfo` structure that points into the buffer. The code in `route_output` references these structures using the names shown in the fifth column in Figure 19.19. The bitmask is also copied into the `rti_addrs` member.
- `route_output` normally modifies the `rt_msghdr` structure. If an error occurs, the corresponding `errno` value is returned in `rtm_errno` (for example, `EEXIST` if the route already exists); otherwise the flag `RTF_DONE` is logically ORed into the `rtm_flags` supplied by the process.
- The `rt_msghdr` structure and the addresses that follow become input to 0 or more processes that are reading from a routing socket. The buffer is first converted back into an mbuf chain by `m_copyback`. `raw_input` goes through all the routing PCBs and passes a copy to the appropriate processes. We also show that a process with a routing socket receives a copy of each message it writes to that socket unless it disables the `SO_USELOOPBACK` socket option.

To avoid receiving a copy of their own routing messages, some programs, such as `route`, call `shutdown` with a second argument of 0 to prevent any data from being received on the routing socket.

We examine the source code for `route_output` in seven parts. Figure 20.7 shows an overview of the function.

```
int
route_output()
{
    R_Malloc() to allocate buffer;
    m_copydata() to copy from mbuf chain into buffer;
    rt_xaddrs() to build rt_addrinfo();

    switch (message type) {
    case RTM_ADD:
        rtrequest(RTM_ADD);
        rt_setmetrics();
        break;
    }
```

```

    case RTM_DELETE:
        rtrequest(RTM_DELETE);
        break;

    case RTM_GET:
    case RTM_CHANGE:
    case RTM_LOCK:
        rtallocl();

        switch (message type) {
        case RTM_GET:
            rt_msg2(RTM_GET);
            break;

        case RTM_CHANGE:
            change appropriate fields;
            /* fall through */

        case RTM_LOCK:
            set rmx_locks;
            break;
        }
        break;
    }

    set rtm_error if error, else set RTF_DONE flag;
    m_copyback() to copy from buffer into mbuf chain;
    raw_input(); /* mbuf chain to appropriate processes */
}

```

Figure 20.7 Summary of route\_output processing steps.

The first part of route\_output is shown in Figure 20.8.

#### Check mbuf for validity

113-136 The mbuf chain is checked for validity: its length must be at least the size of an `rt_msghdr` structure. The first longword is fetched from the data portion of the mbuf, which contains the `rtm_msglen` value.

#### Allocate buffer

137-142 A buffer is allocated to hold the entire message and `m_copydata` copies the message from the mbuf chain into the buffer.

#### Check version number

143-146 The version of the message is checked. In the future, should a new version of the routing messages be introduced, this member could be used to provide support for older versions.

147-149 The process ID is copied into `rtm_pid` and the bitmask supplied by the process is copied into `info.rti_addr`, a structure local to this function. The function `rt_xaddr` (shown in the next section) fills in the eight socket address pointers in the `info` structure to point into the buffer now containing the message.

```

rtsock.c
113 int
114 route_output(m, so)
115 struct mbuf *m;
116 struct socket *so;
117 {
118     struct rt_msghdr *rtm = 0;
119     struct rtentry *rt = 0;
120     struct rtentry *saved_rnt = 0;
121     struct rt_addrinfo info;
122     int len, error = 0;
123     struct ifnet *ifp = 0;
124     struct ifaddr *ifa = 0;
125 #define senderr(e) { error = e; goto flush;}
126     if (m == 0 || ((m->m_len < sizeof(long)) &&
127                 (m = m_pullup(m, sizeof(long))) == 0))
128         return (ENOBUFS);
129     if ((m->m_flags & M_PKTHDR) == 0)
130         panic("route_output");
131     len = m->m_pkthdr.len;
132     if (len < sizeof(*rtm) ||
133         len != mtod(m, struct rt_msghdr *)->rtm_msglen) {
134         dst = 0;
135         senderr(EINVAL);
136     }
137     R_Malloc(rtm, struct rt_msghdr *, len);
138     if (rtm == 0) {
139         dst = 0;
140         senderr(ENOBUFS);
141     }
142     m_copydata(m, 0, len, (caddr_t) rtm);
143     if (rtm->rtm_version != RTM_VERSION) {
144         dst = 0;
145         senderr(EPROTONOSUPPORT);
146     }
147     rtm->rtm_pid = curproc->p_pid;
148     info.rti_addr = rtm->rtm_addr;
149     rt_xaddrs((caddr_t) (rtm + 1), len + (caddr_t) rtm, &info);
150     if (dst == 0)
151         senderr(EINVAL);
152     if (genmask) {
153         struct radix_node *t;
154         t = rn_addmask((caddr_t) genmask, 1, 2);
155         if (t && Bcmp(genmask, t->rn_key, *(u_char *) genmask) == 0)
156             genmask = (struct sockaddr *) (t->rn_key);
157         else
158             senderr(ENOBUFS);
159     }

```

Figure 20.8 route\_output function: initial processing, copy message from mbuf chain.



- rtsock.c

**Destination address required**

150-151 A destination address is a required address for all commands. If the `info.rti_info[RTAX_DST]` element is a null pointer, `EINVAL` is returned. Remember that `dst` refers to this array element (Figure 19.19).

**Handle optional genmask**

152-159 A `genmask` is optional and is used as the network mask for routes created when the `RTF_CLONING` flag is set (Figure 19.8). `rn_addmask` adds the mask to the tree of masks, first searching for an existing entry for the mask and then referencing that entry if found. If the mask is found or added to the mask tree, an additional check is made that the entry in the mask tree really equals the `genmask` value, and, if so, the `genmask` pointer is replaced with a pointer to the mask in the mask tree.

Figure 20.9 shows the next part of `route_output`, which handles the `RTM_ADD` and `RTM_DELETE` commands.

```

160     switch (rtm->rtm_type) {
161     case RTM_ADD:
162         if (gate == 0)
163             senderr(EINVAL);
164         error = rtrequest(RTM_ADD, dst, gate, netmask,
165                         rtm->rtm_flags, &saved_nrt);
166         if (error == 0 && saved_nrt) {
167             rt_setmetrics(rtm->rtm_inits,
168                          &rtm->rtm_rmx, &saved_nrt->rt_rmx);
169             saved_nrt->rt_refcnt--;
170             saved_nrt->rt_genmask = genmask;
171         }
172         break;
173     case RTM_DELETE:
174         error = rtrequest(RTM_DELETE, dst, gate, netmask,
175                         rtm->rtm_flags, (struct rtentry **) 0);
176         break;

```

- rtsock.c

**Figure 20.9** `route_output` function: process `RTM_ADD` and `RTM_DELETE` commands.

162-163 An `RTM_ADD` command requires the process to specify a gateway.  
 164-165 `rtrequest` processes the request. The `netmask` pointer can be null if the route being entered is a host route. If all is OK, the pointer to the new routing table entry is returned through `saved_nrt`.

166-172 The `rt_metrics` structure is copied from the caller's buffer into the routing table entry. The reference count is decremented and the `genmask` pointer is stored (possibly a null pointer).

173-176 Processing the `RTM_DELETE` command is simple because all the work is done by `rtrequest`. Since the final argument is a null pointer, `rtrequest` calls `rt_free` if the reference count is 0, deleting the entry from the routing table (Figure 19.7).

- rtsock.c

The next part of the processing is shown in Figure 20.10, which handles the common code for the RTM\_GET, RTM\_CHANGE, and RTM\_LOCK commands.

```

-----rtsock.c
177     case RTM_GET:
178     case RTM_CHANGE:
179     case RTM_LOCK:
180         rt = rtalloc1(dst, 0);
181         if (rt == 0)
182             senderr(ESRCH);
183         if (rtm->rtm_type != RTM_GET) { /* XXX: too grotty */
184             struct radix_node *rn;
185             extern struct radix_node_head *mask_rnhead;
186
187             if (Bcmp(dst, rt_key(rt), dst->sa_len) != 0)
188                 senderr(ESRCH);
189             if (netmask && (rn = rn_search(netmask,
190                                     mask_rnhead->rnhtree)))
191                 netmask = (struct sockaddr *) rn->rn_key;
192             for (rn = rt->rt_nodes; rn; rn = rn->rn_dupedkey)
193                 if (netmask == (struct sockaddr *) rn->rn_mask)
194                     break;
195             if (rn == 0)
196                 senderr(ETOOMANYREFS);
197             rt = (struct rtable *) rn;
-----rtsock.c

```

Figure 20.10 route\_output function: common processing for RTM\_GET, RTM\_CHANGE, and RTM\_LOCK.

#### Locate existing entry

177-182 Since all three commands reference an existing entry, `rtalloc1` locates the entry. If the entry isn't found, `ESRCH` is returned.

#### Do not allow network match

183-187 For the `RTM_CHANGE` and `RTM_LOCK` commands, a network match is inadequate: an exact match with the routing table key is required. Therefore, if the `dst` argument doesn't equal the routing table key, the match was a network match and `ESRCH` is returned.

#### Use network mask to find correct entry

188-193 Even with an exact match, if there are duplicate keys, each with a different network mask, the correct entry must still be located. If a `netmask` argument was supplied, it is looked up in the mask table (`mask_rnhead`). If found, the `netmask` pointer is replaced with the pointer to the mask in the mask tree. Each leaf node in the duplicate key list is examined, looking for an entry with an `rn_mask` pointer that equals `netmask`. This test compares the pointers, not the structures that they point to. This works because all masks appear in the mask tree, and only one copy of each unique mask is stored in this tree. In the common case, keys are not duplicated, so the `for` loop iterates once. If a host entry is being modified, a mask must not be specified and then both `netmask` and `rn_mask` are null pointers (which are equal). But if an entry that has an associated mask is being modified, that mask must be specified as the `netmask` argument.

the com-

-rtsock.c

-rtsock.c

\_LOCK.

entry. If

uate: an  
rgument  
:SRCH isnetwork  
ied, it is  
replaced  
ey list is  
sk. This  
cause all  
d in this  
nce. If a  
ask and  
sociated

194-195 If the for loop terminates without finding a matching network mask, ETOOMANYREFS is returned.

The comment XXX is because this function must go to all this work to find the desired entry. All these details should be hidden in another function similar to rtablecl that detects a network match and handles a mask argument.

The next part of this function, shown in Figure 20.11, continues processing the RTM\_GET command. This command is unique among the commands supported by route\_output in that it can return more data than it was passed. For example, only a single socket address structure is required as input, the destination, but at least two are returned: the destination and its gateway. With regard to Figure 20.6, this means the buffer allocated for m\_copydata to copy into might need to be increased in size.

```

1) 198     switch (rtm->rtm_type) {
199         case RTM_GET:
200             dst = rt_key(rt);
201             gate = rt->rt_gateway;
202             netmask = rt_mask(rt);
203             genmask = rt->rt_genmask;
204             if (rtm->rtm_addrs & (RTA_IFP | RTA_IFA)) {
205                 if (ifp = rt->rt_ifp) {
206                     ifpaddr = ifp->if_addrlist->ifa_addr;
207                     ifaaddr = rt->rt_ifa->ifa_addr;
208                     rtm->rtm_index = ifp->if_index;
209                 } else {
210                     ifpaddr = 0;
211                     ifaaddr = 0;
212                 }
213             }
214             len = rt_msg2(RTM_GET, &info, (caddr_t) 0,
215                         (struct walkarg *) 0);
216             if (len > rtm->rtm_msglen) {
217                 struct rt_msghdr *new_rtm;
218                 R_Malloc(new_rtm, struct rt_msghdr *, len);
219                 if (new_rtm == 0)
220                     senderr(ENOBUFS);
221                 Bcopy(rtm, new_rtm, rtm->rtm_msglen);
222                 Free(rtm);
223                 rtm = new_rtm;
224             }
225             (void) rt_msg2(RTM_GET, &info, (caddr_t) rtm,
226                         (struct walkarg *) 0);
227             rtm->rtm_flags = rt->rt_flags;
228             rtm->rtm_rmx = rt->rt_rmx;
229             rtm->rtm_addrs = info.rti_addrs;
230             break;

```

rtsock.c

Figure 20.11 route\_output function: RTM\_GET processing.

**Return destination, gateway, and masks**

198-203 Four pointers are stored in the `rti_info` array: `dst`, `gate`, `netmask`, and `genmask`. The latter two might be null pointers. These pointers in the `info` structure point to the socket address structures that will be returned to the process.

**Return interface information**

204-213 The process can set the masks `RTA_IFP` and `RTA_IFA` in the `rtm_flags` bitmask. If either or both are set, the process wants to receive the contents of both the `ifaddr` structures pointed to by this routing table entry: the link-level address of the interface (pointed to by `rt_ifp->if_addrlist`) and the protocol address for this entry (pointed to by `rt_ifa->ifa_addr`). The interface index is also returned.

**Construct reply**

214-224 `rt_msg2` is called with a null third pointer to calculate the length of the routing message corresponding to `RTM_GET` and the addresses pointed to by the `info` structure. If the length of the result message exceeds the length of the input message, then a new buffer is allocated, the input message is copied into the new buffer, the old buffer is released, and `rtm` is set to point to the new buffer.

225-230 `rt_msg2` is called again, this time with a nonnull third pointer, which builds the result message in the buffer. The final three members in the `rt_msghdr` structure are then filled in.

Figure 20.12 shows the processing of the `RTM_CHANGE` and `RTM_LOCK` commands.

**Change gateway**

231-233 If a `gate` address was passed by the process, `rt_setgate` is called to change the gateway for the entry.

**Locate new interface**

234-244 The new gateway (if changed) can also require new `rt_ifp` and `rt_ifa` pointers. The process can specify these new values by passing either an `ifpaddr` socket address structure or an `ifaaddr` socket address structure. The former is tried first, and then the latter. If neither is passed by the process, the `rt_ifp` and `rt_ifa` pointers are left alone.

**Check if interface changed**

245-256 If an interface was located (`ifa` is nonnull), then the existing `rt_ifa` pointer for the route is compared to the new value. If it has changed, new values for `rt_ifp` and `rt_ifa` are stored in the routing table entry. Before doing this the interface request function (if defined) is called with a command of `RTM_DELETE`. The delete is required because the link-layer information from one type of network to another can be quite different, say changing a route from an X.25 network to an Ethernet, and the output routines must be notified.

**Update metrics**

257-258 The metrics in the routing table entry are updated by `rt_setmetrics`.

```

231         case RTM_CHANGE:
232             if (gate && rt_setgate(rt, rt_key(rt), gate))
233                 senderr(EDQUOT);
234             /* new gateway could require new ifaddr, ifp; flags may also be
235             different; ifp may be specified by ll sockaddr when protocol
236             address is ambiguous */
237             if (ifpaddr && (ifa = ifa_ifwithnet(ifpaddr)) &&
238                 (ifp = ifa->ifa_ifp))
239                 ifa = ifaof_ifpforaddr(ifaaddr ? ifaaddr : gate,
240                                         ifp);
241             else if ((ifaaddr && (ifa = ifa_ifwithaddr(ifaaddr))) ||
242                     (ifa = ifa_ifwithroute(rt->rt_flags,
243                                             rt_key(rt), gate)))
244                 ifp = ifa->ifa_ifp;
245             if (ifa) {
246                 struct ifaddr *oifa = rt->rt_ifa;
247                 if (oifa != ifa) {
248                     if (oifa && oifa->ifa_rtrequest)
249                         oifa->ifa_rtrequest(RTM_DELETE,
250                                             rt, gate);
251                     IFAFREE(rt->rt_ifa);
252                     rt->rt_ifa = ifa;
253                     ifa->ifa_refcnt++;
254                     rt->rt_ifp = ifp;
255                 }
256             }
257             rt_setmetrics(rtm->rtm_inits, &rtm->rtm_rmx,
258                          &rt->rt_rmx);
259             if (rt->rt_ifa && rt->rt_ifa->ifa_rtrequest)
260                 rt->rt_ifa->ifa_rtrequest(RTM_ADD, rt, gate);
261             if (genmask)
262                 rt->rt_genmask = genmask;
263             /*
264             * Fall into
265             */
266             case RTM_LOCK:
267                 rt->rt_rmx.rmx_locks &= ~(rtm->rtm_inits);
268                 rt->rt_rmx.rmx_locks |=
269                     (rtm->rtm_inits & rtm->rtm_rmx.rmx_locks);
270                 break;
271             }
272             break;
273         default:
274             senderr(EOPNOTSUPP);
275     }

```

Figure 20.12 route\_output function: RTM\_CHANGE and RTM\_LOCK processing.

#### Call interface request function

259-260 If an interface request function is defined, it is called with a command of RTM\_ADD.

**Store clone generation mask**

261-262 If the process specifies the `genmask` argument, the pointer to the mask that was obtained in Figure 20.8 is saved in `rt_genmask`.

**Update bitmask of locked metrics**

266-270 The `RTM_LOCK` command updates the bitmask stored in `rt_rmx.rmx_locks`. Figure 20.13 shows the values of the different bits in this bitmask, one value per metric.

Constant	Value	Description
<code>RTV_MTU</code>	0x01	initialize or lock <code>rmx_mtu</code>
<code>RTV_HOPCOUNT</code>	0x02	initialize or lock <code>rmx_hopcount</code>
<code>RTV_EXPIRE</code>	0x04	initialize or lock <code>rmx_expire</code>
<code>RTV_RPIPE</code>	0x08	initialize or lock <code>rmx_recvpipe</code>
<code>RTV_SPIPE</code>	0x10	initialize or lock <code>rmx_sendpipe</code>
<code>RTV_SSTHRESH</code>	0x20	initialize or lock <code>rmx_ssthresh</code>
<code>RTV_RTT</code>	0x40	initialize or lock <code>rmx_rtt</code>
<code>RTV_RTTVAR</code>	0x80	initialize or lock <code>rmx_rttvar</code>

Figure 20.13 Constants to initialize or lock metrics.

The `rmx_locks` member of the `rt_metrics` structure in the routing table entry is the bitmask telling the kernel which metrics to leave alone. That is, those metrics specified by `rmx_locks` won't be updated by the kernel. The only use of these metrics by the kernel is with TCP, as noted with Figure 27.3. The `rmx_pksent` metric cannot be locked or initialized, but it turns out this member is never even referenced or updated by the kernel.

The `rtm_inits` value in the message from the process specifies the bitmask of which metrics were just initialized by `rt_setmetrics`. The `rtm_rmx.rmx_locks` value in the message specifies the bitmask of which metrics should now be locked. The value of `rt_rmx.rmx_locks` is the bitmask in the routing table of which metrics are currently locked. First, any bits to be initialized (`rtm_inits`) are unlocked. Any bits that are both initialized (`rtm_inits`) and locked (`rtm_rmx.rmx_locks`) are locked.

273-275 This default is for the switch at the beginning of Figure 20.9 and catches any of the routing commands other than the five that are supported in messages from a process.

The final part of `route_output`, shown in Figure 20.14, sends the reply to `raw_input`.

2

2

```

276 flush:
277     if (rtm) {
278         if (error)
279             rtm->rtm_errno = error;
280         else
281             rtm->rtm_flags |= RTF_DONE;
282     }
283     if (rt)
284         rtfree(rt);
285     {
286         struct rawcb *rp = 0;
287         /*
288          * Check to see if we don't want our own messages.
289          */
290         if ((so->so_options & SO_USELOOPBACK) == 0) {
291             if (route_cb.any_count <= 1) {
292                 if (rtm)
293                     Free(rtm);
294                 m_freem(m);
295                 return (error);
296             }
297             /* There is another listener, so construct message */
298             rp = sotorawcb(so);
299         }
300         if (rtm) {
301             m_copyback(m, 0, rtm->rtm_msglen, (caddr_t) rtm);
302             Free(rtm);
303         }
304         if (rp)
305             rp->rcb_proto.sp_family = 0;    /* Avoid us */
306         if (dst)
307             route_proto.sp_protocol = dst->sa_family;
308         raw_input(m, &route_proto, &route_src, &route_dst);
309         if (rp)
310             rp->rcb_proto.sp_family = PF_ROUTE;
311     }
312     return (error);
313 }

```

Figure 20.14 route\_output function: pass results to raw\_input.

#### Return error or OK

276-282 flush is the label jumped to by the `senderr` macro defined at the beginning of the function. If an error occurred it is returned in the `rtm_errno` member; otherwise the `RTF_DONE` flag is set.

#### Release held route

283-284 If a route is being held, it is released. The call to `rtalloc1` at the beginning of Figure 20.10 holds the route, if found.

**No process to receive message**

285-296 The `SO_USELOOPBACK` socket option is true by default and specifies that the sending process is to receive a copy of each routing message that it writes to a routing socket. (If the sender doesn't receive a copy, it can't receive any of the information returned by `RTM_GET`.) If that option is not set, and the total count of routing sockets is less than or equal to 1, there are no other processes to receive the message and the sender doesn't want a copy. The buffer and mbuf chain are both released and the function returns.

**Other listeners but no loopback copy**

297-299 There is at least one other listener but the sending process does not want a copy. The pointer `rp`, which defaults to null, is set to point to the routing control block for the sender and is also used as a flag that the sender doesn't want a copy.

**Convert buffer into mbuf chain**

300-303 The buffer is converted back into an mbuf chain (Figure 20.6) and the buffer released.

**Avoid loopback copy**

304-305 If `rp` is set, some other process might want the message but the sender does not want a copy. The `sp_family` member of the sender's routing control block is temporarily set to 0, but the `sp_family` of the message (the `route_proto` structure, shown with Figure 19.26) has a family of `PF_ROUTE`. This trick prevents `raw_input` from passing a copy of the result to the sending process because `raw_input` does not pass a copy to any socket with an `sp_family` of 0.

**Set address family of routing message**

306-308 If `dst` is a nonnull pointer, the address family of that socket address structure becomes the protocol of the routing message. With the Internet protocols this value would be `PF_INET`. A copy is passed to the appropriate listeners by `raw_input`.

309-313 If the `sp_family` member in the calling process was temporarily set to 0, it is reset to `PF_ROUTE`, its normal value.

## 20.6 `rt_xaddrs` Function

The `rt_xaddrs` function is called only once from `route_output` (Figure 20.8) after the routing message from the process has been copied from the mbuf chain into a buffer and after the bitmask from the process (`rtm_addrs`) has been copied into the `rti_info` member of an `rt_addrinfo` structure. The purpose of `rt_xaddrs` is to take this bitmask and set the pointers in the `rti_info` array to point to the corresponding address in the buffer. Figure 20.15 shows the function.

```

330 #define ROUNDUP(a) \
331     ((a) > 0 ? (1 + ((a) - 1) | (sizeof(long) - 1)) : sizeof(long))
332 #define ADVANCE(x, n) (x += ROUNDUP(n)->sa_len)

```

rtsock.c



```

333 static void
334 rt_xaddrs(cp, cplim, rtinfo)
335 caddr_t cp, cplim;
336 struct rt_addrinfo *rtinfo;
337 {
338     struct sockaddr *sa;
339     int i;
340     bzero(rtinfo->rta_info, sizeof(rtinfo->rta_info));
341     for (i = 0; (i < RTAX_MAX) && (cp < cplim); i++) {
342         if ((rtinfo->rta_addrs & (1 << i)) == 0)
343             continue;
344         rtinfo->rta_info[i] = sa = (struct sockaddr *) cp;
345         ADVANCE(cp, sa);
346     }
347 }

```

*rtsock.c*

Figure 20.15 `rt_xaddrs` function: fill `rta_info` array with pointers.

330-340 The array of pointers is set to 0 so all the pointers to address structures not appearing in the bitmask will be null.

341-347 Each of the 8 (RTAX\_MAX) possible bits in the bitmask is tested and, if set, a pointer is stored in the `rta_info` array to the corresponding socket address structure. The ADVANCE macro takes the `sa_len` field of the socket address structure, rounds it up to the next multiple of 4 bytes, and increments the pointer `cp` accordingly.

## 20.7 `rt_setmetrics` Function

This function was called twice from `route_output`: when a new route was added and when an existing route was changed. The `rtm_inits` member in the routing message from the process specifies which of the metrics the process wants to initialize from the `rtm_rmx` array. The bit values in the bitmask are shown in Figure 20.13.

Notice that both `rtm_addrs` and `rtm_inits` are bitmasks in the message from the process, the former specifying the socket address structures that follow, and the latter specifying which metrics are to be initialized. Socket address structures whose bits don't appear in `rtm_addrs` don't even appear in the routing message, to save space. But the entire `rt_metrics` array always appears in the fixed-length `rt_msghdr` structure—elements in the array whose bits are not set in `rtm_inits` are ignored.

Figure 20.16 shows the `rt_setmetrics` function.

314-318 The `which` argument is always the `rtm_inits` member of the routing message from the process. `in` points to the `rt_metrics` structure from the process, and `out` points to the `rt_metrics` structure in the routing table entry that is being created or modified.

319-329 Each of the 8 bits in the bitmask is tested and if set, the corresponding metric is copied. Notice that when a new routing table entry is being created with the `RTM_ADD` command, `route_output` calls `rtrequest`, which sets the entire routing table entry to 0 (Figure 19.9). Hence, any metrics not specified by the process in the routing message default to 0.

that the send-  
to a routing  
e information  
ting sockets is  
essage and the  
and the func-

want a copy.  
l block for the

nd the buffer

nder does not  
block is tem-  
to structure,  
s raw\_input  
put does not

less structure  
ols this value  
\_input.  
to 0, it is reset

ure 20.8) after  
in into a buffer  
pied into the  
\_xaddrs is to  
ae correspond-

rtsock.c  
(long)

```

-----rtsock.c
314 void
315 rt_setmetrics(which, in, out)
316 u_long which;
317 struct rt_metrics *in, *out;
318 {
319 #define metric(f, e) if (which & (f)) out->e = in->e;
320     metric(RTV_RPIPE, rmx_recvpipe);
321     metric(RTV_SPIPE, rmx_sendpipe);
322     metric(RTV_SSTHRESH, rmx_ssthresh);
323     metric(RTV_RTT, rmx_rtt);
324     metric(RTV_RTTVAR, rmx_rttvar);
325     metric(RTV_HOPCOUNT, rmx_hopcount);
326     metric(RTV_MTU, rmx_mtu);
327     metric(RTV_EXPIRE, rmx_expire);
328 #undef metric
329 }
-----rtsock.c

```

Figure 20.16 `rt_setmetrics` function: set elements of the `rt_metrics` structure.

## 20.8 raw\_input Function

All routing messages destined for a process—those that originate from within the kernel and those that originate from a process—are given to `raw_input`, which selects the processes to receive the message. Figure 18.11 summarizes the four functions that call `raw_input`.

When a routing socket is created, the family is always `PF_ROUTE` and the protocol, the third argument to `socket`, can be 0, which means the process wants to receive all routing messages, or a value such as `AF_INET`, which restricts the socket to messages containing addresses of that specific protocol family. A routing control block is created for each routing socket (Section 20.3) and these two values are stored in the `sp_family` and `sp_protocol` members of the `rcb_proto` structure.

Figure 20.17 shows the `raw_input` function.

```

-----raw_usrreq.c
51 void
52 raw_input(m0, proto, src, dst)
53 struct mbuf *m0;
54 struct sockproto *proto;
55 struct sockaddr *src, *dst;
56 {
57     struct rawcb *rp;
58     struct mbuf *m = m0;
59     int sockets = 0;
60     struct socket *last;

```

ock.c

ock.c

ker-  
s the  
callocol,  
e all  
ages  
ated  
uily

rreq.c

```

61     last = 0;
62     for (rp = rawcb.rcb_next; rp != &rawcb; rp = rp->rcb_next) {
63         if (rp->rcb_proto.sp_family != proto->sp_family)
64             continue;
65         if (rp->rcb_proto.sp_protocol &&
66             rp->rcb_proto.sp_protocol != proto->sp_protocol)
67             continue;
68         /*
69          * We assume the lower level routines have
70          * placed the address in a canonical format
71          * suitable for a structure comparison.
72          *
73          * Note that if the lengths are not the same
74          * the comparison will fail at the first byte.
75          */
76         #define equal(a1, a2) \
77             (bcmp((caddr_t)(a1), (caddr_t)(a2), a1->sa_len) == 0)
78         if (rp->rcb_laddr && !equal(rp->rcb_laddr, dst))
79             continue;
80         if (rp->rcb_faddr && !equal(rp->rcb_faddr, src))
81             continue;
82         if (last) {
83             struct mbuf *n;
84             if (n = m_copy(m, 0, (int) M_COPYALL)) {
85                 if (sbappendaddr(&last->so_rcv, src,
86                                 n, (struct mbuf *) 0) == 0)
87                     /* should notify about lost packet */
88                     m_freem(n);
89                 else {
90                     sorwakeup(last);
91                     sockets++;
92                 }
93             }
94         }
95         last = rp->rcb_socket;
96     }
97     if (last) {
98         if (sbappendaddr(&last->so_rcv, src,
99                         m, (struct mbuf *) 0) == 0)
100             m_freem(m);
101         else {
102             sorwakeup(last);
103             sockets++;
104         }
105     } else
106         m_freem(m);
107 }

```

-raw\_usrreq.c

Figure 20.17 raw\_input function: pass routing messages to 0 or more processes.

51-61 In all four calls to `raw_input` that we've seen, the `proto`, `src`, and `dst` arguments are pointers to the three globals `route_proto`, `route_src`, and `route_dst`, which are declared and initialized as shown with Figure 19.26.

#### Compare address family and protocol

62-67 The `for` loop goes through every routing control block checking for a match. The family in the control block (normally `PF_ROUTE`) must match the family in the `sockproto` structure or the control block is skipped. Next, if the protocol in the control block (the third argument to `socket`) is nonzero, it must match the family in the `sockproto` structure, or the message is skipped. Hence a process that creates a routing socket with a protocol of 0 receives all routing messages.

#### Compare local and foreign addresses

68-81 These two tests compare the local address in the control block and the foreign address in the control block, if specified. Currently the process is unable to set the `rcb_laddr` or `rcb_faddr` members of the control block. Normally a process would set the former with `bind` and the latter with `connect`, but that is not possible with routing sockets in Net/3. Instead, we'll see that `route_usrreq` permanently connects the socket to the `route_src` socket address structure, which is OK since that is always the `src` argument to this function.

#### Append message to socket receive buffer

82-107 If `last` is nonnull, it points to the most recently seen `socket` structure that should receive this message. If this variable is nonnull, a copy of the message is appended to that socket's receive buffer by `m_copy` and `sbappendaddr`, and any processes waiting on this receive buffer are awakened. Then `last` is set to point to this socket that just matched the previous tests. The use of `last` is to avoid calling `m_copy` (an expensive operation) if only one process is to receive the message.

If  $N$  processes are to receive the message, the first  $N - 1$  receive a copy and the final one receives the message itself.

The variable `sockets` that is incremented within this function is not used. Since it is incremented only when a message is passed to a process, if it is 0 at the end of the function it indicates that no process received the message (but the value isn't stored anywhere).

## 20.9 route\_usrreq Function

`route_usrreq` is the routing protocol's user-request function. It is called for a variety of operations. Figure 20.18 shows the function.

```

64 int
65 route_usrreq(so, req, m, nam, control)
66 struct socket *so;
67 int req;
68 struct mbuf *m, *nam, *control;
69 {

```

rtsock.c

```

70     int     error = 0;
71     struct rawcb *rp = sotorawcb(so);
72     int     s;

73     if (req == PRU_ATTACH) {
74         MALLOC(rp, struct rawcb *, sizeof(*rp), M_PCB, M_WAITOK);
75         if (so->so_pcb = (caddr_t) rp)
76             bzero(so->so_pcb, sizeof(*rp));
77     }
78     if (req == PRU_DETACH && rp) {
79         int     af = rp->rcb_proto.sp_protocol;
80         if (af == AF_INET)
81             route_cb.ip_count--;
82         else if (af == AF_NS)
83             route_cb.ns_count--;
84         else if (af == AF_ISO)
85             route_cb.iso_count--;
86         route_cb.any_count--;
87     }
88     s = splnet();
89     error = raw_usrreq(so, req, m, nam, control);
90     rp = sotorawcb(so);
91     if (req == PRU_ATTACH && rp) {
92         int     af = rp->rcb_proto.sp_protocol;
93         if (error) {
94             free((caddr_t) rp, M_PCB);
95             splx(s);
96             return (error);
97         }
98         if (af == AF_INET)
99             route_cb.ip_count++;
100        else if (af == AF_NS)
101            route_cb.ns_count++;
102        else if (af == AF_ISO)
103            route_cb.iso_count++;
104        route_cb.any_count++;

105        rp->rcb_faddr = &route_src;
106        soisconnected(so);
107        so->so_options |= SO_USELOOPBACK;
108    }
109    splx(s);
110    return (error);
111 }

```

rtsock.c

Figure 20.18 route\_usrreq function: process PRU\_xxx requests.

**PRU\_ATTACH: allocate control block**

64-77 The PRU\_ATTACH request is issued when the process calls `socket`. Memory is allocated for a routing control block. The pointer returned by `MALLOC` is stored in the `so_pcb` member of the `socket` structure, and if the memory was allocated, the `rawcb` structure is set to 0.

**PRU\_DETACH: decrement counters**

78-87 The `close` system call issues the `PRU_DETACH` request. If the socket structure points to a protocol control block, two of the counters in the `route_cb` structure are decremented: one is the `any_count` and one is based on the protocol.

**Process request**

88-90 The function `raw_usrreq` is called to process the `PRU_XXX` request further.

**Increment counters**

91-104 If the request is `PRU_ATTACH` and the socket points to a routing control block, a check is made for an error from `raw_usrreq`. Two of the counters in the `route_cb` structure are then incremented: one is the `any_count` and one is based on the protocol.

**Connect socket**

105-106 The foreign address in the routing control block is set to `route_src`. This permanently connects the new socket to receive routing messages from the `PF_ROUTE` family.

**Enable `SO_USELOOPBACK` by default**

107-111 The `SO_USELOOPBACK` socket option is enabled. This is a socket option that defaults to being enabled—all others default to being disabled.

**20.10 `raw_usrreq` Function**

`raw_usrreq` performs most of the processing for the user request in the routing domain. It was called by `route_usrreq` in the previous section. The reason the user-request processing is divided between these two functions is that other protocols (e.g., the OSI CLNP) call `raw_usrreq` but not `route_usrreq`. `raw_usrreq` is not intended to be the `pr_usrreq` function for a protocol. Instead it is a common subroutine called by the various `pr_usrreq` functions.

Figure 20.19 shows the beginning and end of the `raw_usrreq` function. The body of the switch is discussed in separate figures following this figure.

**PRU\_CONTROL requests invalid**

119-129 The `PRU_CONTROL` request is from the `ioctl` system call and is not supported in the routing domain.

**Control information invalid**

130-133 If control information was passed by the process (using the `sendmsg` system call) an error is returned, since the routing domain doesn't use this optional information.

**Socket must have a control block**

134-137 If the socket structure doesn't point to a routing control block, an error is returned. If a new socket is being created, it is the caller's responsibility (i.e., `route_usrreq`) to allocate this control block and store the pointer in the `so_pcb` member before calling this function.

262-269 The default for this switch catches two requests that are not handled by case statements: `PRU_BIND` and `PRU_CONNECT`. The code for these two requests is present but commented out in `Net/3`. Therefore issuing the `bind` or `connect` system calls on a

structure  
are

block, a  
ite\_cb  
rotocol.

perma-  
family.

on that

routing  
the user-  
ols (e.g.,  
1 is not  
subrou-

the body

orted in

.tem call)  
tion.

error is  
ility (i.e.,  
so\_pcb

by case  
is present  
calls on a

```

119 int
120 raw_usrreq(so, req, m, nam, control)
121 struct socket *so;
122 int req;
123 struct mbuf *m, *nam, *control;
124 {
125     struct rawcb *rp = sotorawcb(so);
126     int error = 0;
127     int len;
128     if (req == PRU_CONTROL)
129         return (EOPNOTSUPP);
130     if (control && control->m_len) {
131         error = EOPNOTSUPP;
132         goto release;
133     }
134     if (rp == 0) {
135         error = EINVAL;
136         goto release;
137     }
138     switch (req) {
139
140         /* switch cases */
141
142     default:
143         panic("raw_usrreq");
144     }
145     release:
146     if (m != NULL)
147         m_freem(m);
148     return (error);
149 }

```

Figure 20.19 Body of raw\_usrreq function.

routing socket causes a kernel panic. This is a bug. Fortunately it requires a superuser process to create this type of socket.

We now discuss the individual case statements. Figure 20.20 shows the processing for the PRU\_ATTACH and PRU\_DETACH requests.

139-148 The PRU\_ATTACH request is a result of the socket system call. A routing socket must be created by a superuser process.

149-150 The function raw\_attach (Figure 20.24) links the control block into the doubly linked list. The nam argument is the third argument to socket and gets stored in the control block.

151-159 The PRU\_DETACH is issued by the close system call. The test of a null rp pointer is superfluous, since the test was already done before the switch statement.

160-161 raw\_detach (Figure 20.25) removes the control block from the doubly linked list.

```

raw_usrreq.c
139      /*
140      * Allocate a raw control block and fill in the
141      * necessary info to allow packets to be routed to
142      * the appropriate raw interface routine.
143      */
144      case PRU_ATTACH:
145      if ((so->so_state & SS_PRIV) == 0) {
146          error = EACCES;
147          break;
148      }
149      error = raw_attach(so, (int) nam);
150      break;

151      /*
152      * Destroy state just before socket deallocation.
153      * Flush data or not depending on the options.
154      */
155      case PRU_DETACH:
156      if (rp == 0) {
157          error = ENOTCONN;
158          break;
159      }
160      raw_detach(rp);
161      break;
raw_usrreq.c

```

Figure 20.20 raw\_usrreq function: PRU\_ATTACH and PRU\_DETACH requests.

Figure 20.21 shows the processing of the PRU\_CONNECT2, PRU\_DISCONNECT, and PRU\_SHUTDOWN requests.

```

raw_usrreq.c
186      case PRU_CONNECT2:
187          error = EOPNOTSUPP;
188          goto release;

189      case PRU_DISCONNECT:
190      if (rp->rcb_faddr == 0) {
191          error = ENOTCONN;
192          break;
193      }
194      raw_disconnect(rp);
195      soisdisconnected(so);
196      break;

197      /*
198      * Mark the connection as being incapable of further input.
199      */
200      case PRU_SHUTDOWN:
201          socantsendmore(so);
202          break;
raw_usrreq.c

```

Figure 20.21 raw\_usrreq function: PRU\_CONNECT2, PRU\_DISCONNECT, and PRU\_SHUTDOWN requests.

186-188

189-196

197-202

F

r

l

s

a

a

-

2

2

2

2

2

2

2

2

2

2

2

2

2

2

2

2

2

2

2

2

2

2

2

2

2

-

203-217

H

e

r



usrreq.c

186-188 The PRU\_CONNECT2 request is from the socketpair system call and is not supported in the routing domain.

189-196 Since a routing socket is always connected (Figure 20.18), the PRU\_DISCONNECT request is issued by close before the PRU\_DETACH request. The socket must already be connected to a foreign address, which is always true for a routing socket. raw\_disconnect and soisdisconnected complete the processing.

197-202 The PRU\_SHUTDOWN request is from the shutdown system call when the argument specifies that no more writes will be performed on the socket. socantsendmore disables further writes.

The most common request for a routing socket, PRU\_SEND, and the PRU\_ABORT and PRU\_SENSE requests are shown in Figure 20.22.

usrreq.c

T, and

usrreq.c

```

203      /*
204      * Ship a packet out. The appropriate raw output
205      * routine handles any massaging necessary.
206      */
207      case PRU_SEND:
208          if (nam) {
209              if (rp->rcb_faddr) {
210                  error = EISCONN;
211                  break;
212              }
213              rp->rcb_faddr = mtod(nam, struct sockaddr *);
214          } else if (rp->rcb_faddr == 0) {
215              error = ENOTCONN;
216              break;
217          }
218          error = (*so->so_proto->pr_output) (m, so);
219          m = NULL;
220          if (nam)
221              rp->rcb_faddr = 0;
222          break;
223      case PRU_ABORT:
224          raw_disconnect(rp);
225          sofree(so);
226          soisdisconnected(so);
227          break;
228      case PRU_SENSE:
229          /*
230          * stat: don't bother with a blocksize.
231          */
232          return (0);

```

Figure 20.22 raw\_usrreq function: PRU\_SEND, PRU\_ABORT, and PRU\_SENSE requests.

usrreq.c  
requests.

203-217 The PRU\_SEND request is issued by sosend when the process writes to the socket. If a nam argument is specified, that is, the process specified a destination address using either sendto or sendmsg, an error is returned because route\_usrreq always sets rcb\_faddr for a routing socket.

- 218-222 The message in the mbuf chain pointed to by *m* is passed to the protocol's *pr\_output* function, which is *route\_output*.
- 223-227 If a PRU\_ABORT request is issued, the control block is disconnected, the socket is released, and the socket is disconnected.
- 228-232 The PRU\_SENSE request is issued by the *fstat* system call. The function returns OK.

Figure 20.23 shows the remaining PRU\_XXX requests.

```

raw_usrreq.c
233      /*
234      * Not supported.
235      */
236      case PRU_RCVOOB:
237      case PRU_RCVD:
238          return (EOPNOTSUPP);

239      case PRU_LISTEN:
240      case PRU_ACCEPT:
241      case PRU_SENDOOB:
242          error = EOPNOTSUPP;
243          break;

244      case PRU_SOCKADDR:
245          if (rp->rcb_laddr == 0) {
246              error = EINVAL;
247              break;
248          }
249          len = rp->rcb_laddr->sa_len;
250          bcopy((caddr_t) rp->rcb_laddr, mtod(nam, caddr_t), (unsigned) len);
251          nam->m_len = len;
252          break;

253      case PRU_PEERADDR:
254          if (rp->rcb_faddr == 0) {
255              error = ENOTCONN;
256              break;
257          }
258          len = rp->rcb_faddr->sa_len;
259          bcopy((caddr_t) rp->rcb_faddr, mtod(nam, caddr_t), (unsigned) len);
260          nam->m_len = len;
261          break;
raw_usrreq.c

```

Figure 20.23 raw\_usrreq function: final part.

- 233-243 These five requests are not supported.
- 244-261 The PRU\_SOCKADDR and PRU\_PEERADDR requests are from the *getsockname* and *getpeername* system calls respectively. The former always returns an error, since the *bind* system call, which sets the local address, is not supported in the routing domain. The latter always returns the contents of the socket address structure *route\_src*, which was set by *route\_usrreq* as the foreign address.

ocol's

cket is

eturns

usrreq.c

## 20.11 raw\_attach, raw\_detach, and raw\_disconnect Functions

The `raw_attach` function, shown in Figure 20.24, was called by `raw_input` to finish processing the `PRU_ATTACH` request.

```

49 int
50 raw_attach(so, proto)
51 struct socket *so;
52 int proto;
53 {
54     struct rawcb *rp = sotorawcb(so);
55     int error;
56     /*
57      * It is assumed that raw_attach is called
58      * after space has been allocated for the
59      * rawcb.
60      */
61     if (rp == 0)
62         return (ENOBUFS);
63     if (error = soreserve(so, raw_sendspace, raw_recvspace))
64         return (error);
65     rp->rcb_socket = so;
66     rp->rcb_proto.sp_family = so->so_proto->pr_domain->dom_family;
67     rp->rcb_proto.sp_protocol = proto;
68     insque(rp, &rawcb);
69     return (0);
70 }

```

*raw\_cb.c*

len);

Figure 20.24 raw\_attach function.

49-64 The caller must have already allocated the raw protocol control block. `soreserve` sets the high-water marks for the send and receive buffers to 8192. This should be more than adequate for the routing messages.

65-67 A pointer to the `socket` structure is stored in the protocol control block along with the `dom_family` (which is `PF_ROUTE` from Figure 20.1 for the routing domain) and the `proto` argument (which is the third argument to `socket`).

len);

68-70 `insque` adds the control block to the front of the doubly linked list headed by the global `rawcb`.

usrreq.c

The `raw_detach` function, shown in Figure 20.25, was called by `raw_input` to finish processing the `PRU_DETACH` request.

75-84 The `so_pcb` pointer in the `socket` structure is set to null and the socket is released. The control block is removed from the doubly linked list by `remque` and the memory used for the control block is released by `free`.

ame and

since the

domain.

se\_src,

The `raw_disconnect` function, shown in Figure 20.26, was called by `raw_input` to process the `PRU_DISCONNECT` and `PRU_ABORT` requests.

88-94 If the socket does not reference a descriptor, `raw_detach` releases the socket and control block.

```

raw_cb.c
75 void
76 raw_detach(rp)
77 struct rawcb *rp;
78 {
79     struct socket *so = rp->rcb_socket;
80     so->so_pcb = 0;
81     sofree(so);
82     remque(rp);
83     free((caddr_t) (rp), M_PCB);
84 }
raw_cb.c

```

Figure 20.25 raw\_detach function.

```

raw_cb.c
88 void
89 raw_disconnect(rp)
90 struct rawcb *rp;
91 {
92     if (rp->rcb_socket->so_state & SS_NOFDREF)
93         raw_detach(rp);
94 }
raw_cb.c

```

Figure 20.26 raw\_disconnect function.

## 20.12 Summary

A routing socket is a raw socket in the `PF_ROUTE` domain. Routing sockets can be created only by a superuser process. If a nonprivileged process wants to read the routing information contained in the kernel, the `sysctl` system call supported by the routing domain can be used (we described this in the previous chapter).

This chapter was our first encounter with the protocol control blocks (PCBs) that are normally associated with each socket. In the routing domain a special `rawcb` contains information about the routing socket: the local and foreign addresses, the address family, and the protocol. We'll see in Chapter 22 that the larger Internet protocol control block (`inpcb`) is used with UDP, TCP, and raw IP sockets. The concepts are the same, however: the `socket` structure is used by the socket layer, and the PCB, a `rawcb` or an `inpcb`, is used by the protocol layer. The `socket` structure points to the PCB and vice versa.

The `route_output` function handles the five routing requests that can be issued by a process. `raw_input` delivers a routing message to one or more routing sockets, depending on the protocol and address family. The various `PRU_xxx` requests for a routing socket are handled by `raw_usrreq` and `route_usrreq`. In later chapters we'll encounter additional `xxx_usrreq` functions, one per protocol (UDP, TCP, and raw IP), each consisting of a `switch` statement to handle each request.

### Exercises

- 20.1 List two ways a process can receive the return value from `route_output` when the process writes a message to a routing socket. Which method is more reliable?
- 20.2 What happens when a process specifies a nonzero *protocol* argument to the `socket` system call, since the `pr_protocol` member of the `routesw` structure is 0?
- 20.3 Routes in the routing table (other than ARP entries) never time out. Implement a timeout on routes.

b.c

b.c

b.c

cb.c

re-  
ing  
ing

are  
ins  
un-  
trol  
me,  
an  
rice

ied  
ets,  
or a  
ters  
aw

21.1

21.2

# 21

## ***ARP: Address Resolution Protocol***

### **21.1 Introduction**

ARP, the Address Resolution Protocol, handles the translation of 32-bit IP addresses into the corresponding hardware address. For an Ethernet, the hardware addresses are 48-bit Ethernet addresses. In this chapter we only consider mapping IP addresses into 48-bit Ethernet addresses, although ARP is more general and can work with other types of data links. ARP is specified in RFC 826 [Plummer 1982].

When a host has an IP datagram to send to another host on a locally attached Ethernet, the local host first looks up the destination host in the *ARP cache*, a table that maps a 32-bit IP address into its corresponding 48-bit Ethernet address. If the entry is found for the destination, the corresponding Ethernet address is copied into the Ethernet header and the datagram is added to the appropriate interface's output queue. If the entry is not found, the ARP functions hold onto the IP datagram, broadcast an ARP request asking the destination host for its Ethernet address, and, when a reply is received, send the datagram to its destination.

This simple overview handles the common case, but there are many details that we describe in this chapter as we examine the Net/3 implementation of ARP. Chapter 4 of Volume 1 contains additional ARP examples.

### **21.2 ARP and the Routing Table**

The Net/3 implementation of ARP is tied to the routing table, which is why we postponed discussing ARP until we had described the structure of the Net/3 routing tables. Figure 21.1 shows an example that we use in this chapter when describing ARP.

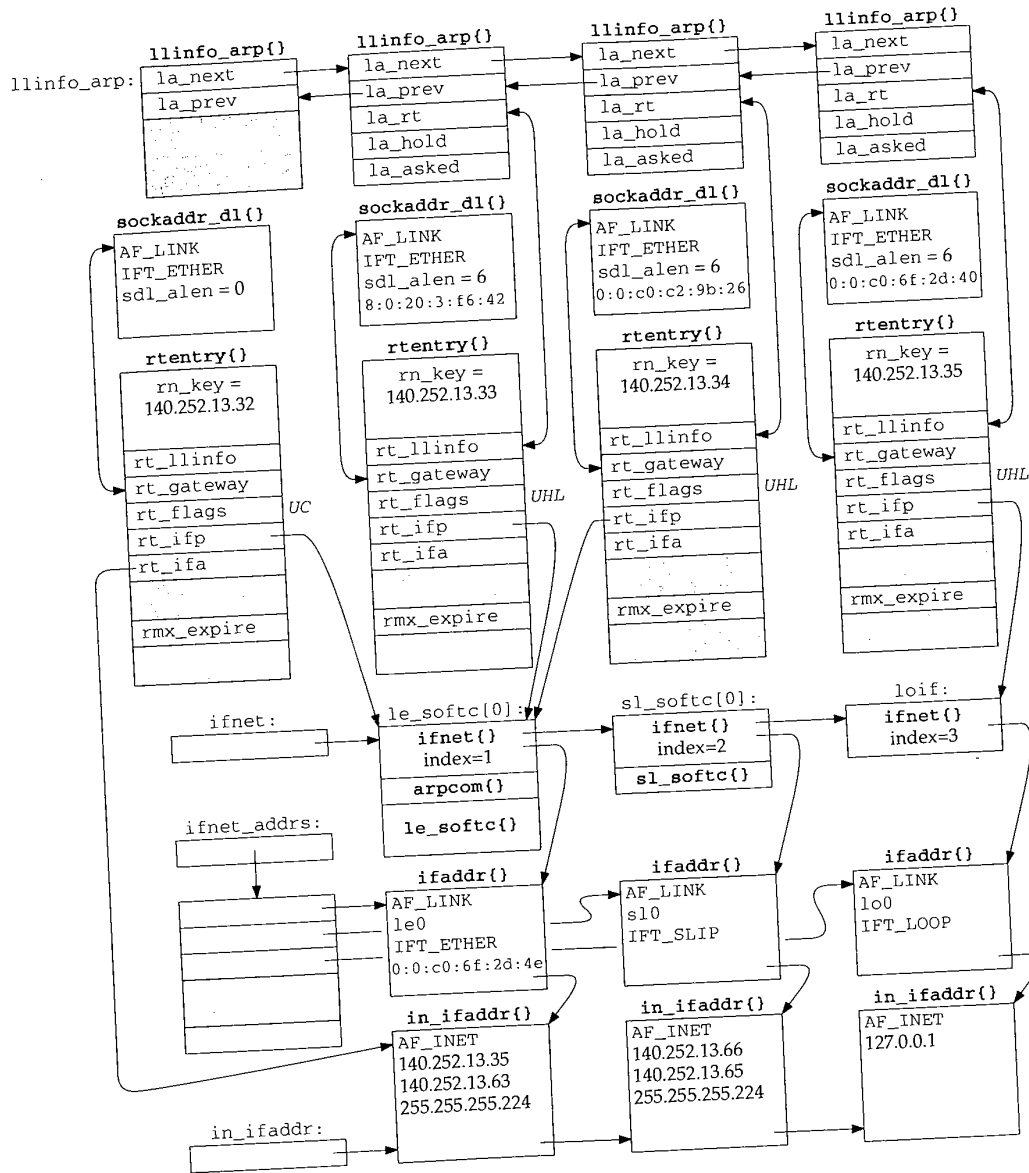
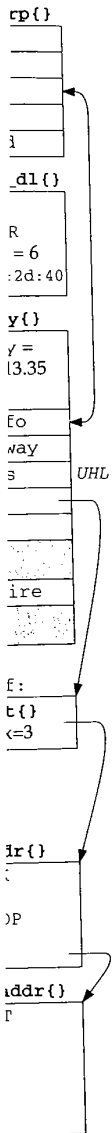

Figure 21.1 Relationship of ARP to routing table and interface structures.

The entire figure corresponds to the example network used throughout the text (Figure 1.17). It shows the ARP entries on the system `bsdi`. The `ifnet`, `ifaddr`, and `in_ifaddr` structures are simplified from Figures 3.32 and 6.5. We have removed some of the details from these three structures, which were covered in Chapters 3 and 6.





For example, we don't show the two `sockaddr_dl` structures that appear after each `ifaddr` structure—instead we summarize the information contained in these two structures. Similarly, we summarize the information contained in the three `in_ifaddr` structures.

We briefly summarize some relevant points from this figure, the details of which we cover as we proceed through the chapter.

1. A doubly linked list of `llinfo_arp` structures contains a minimal amount of information for each hardware address known by ARP. The global `llinfo_arp` is the head of this list. Not shown in this figure is that the `la_prev` pointer of the first entry points to the last entry, and the `la_next` pointer of the last entry points to the first entry. This linked list is processed by the ARP timer function every 5 minutes.
2. For each IP address with a known hardware address, a routing table entry exists (an `rtentry` structure). The `llinfo_arp` structure points to the corresponding `rtentry` structure, and vice versa, using the `la_rt` and `rt_llinfo` pointers. The three routing table entries in this figure with an associated `llinfo_arp` structure are for the hosts `sun` (140.252.13.33), `svr4` (140.252.13.34), and `bsd` itself (140.252.13.35). These three are also shown in Figure 18.2.
3. We show a fourth routing table entry on the left, without an `llinfo_arp` structure, which is the entry for the network route to the local Ethernet (140.252.13.32). We show its `rt_flags` with the `C` bit on, since this entry is cloned to form the other three routing table entries. This entry is created by the call to `rtinit` when the IP address is assigned to the interface by `in_ifinit` (Figure 6.19). The other three entries are host entries (the `H` flag) and are generated by ARP (the `L` flag) when a datagram is sent to that IP address.
4. The `rt_gateway` member of the `rtentry` structure points to a `sockaddr_dl` structure. This data-link socket address structure contains the hardware address if the `sdl_alen` member equals 6.
5. The `rt_ifp` member of the routing table entry points to the `ifnet` structure of the outgoing interface. Notice that the two routing table entries in the middle, for other hosts on the local Ethernet, both point to `le_softc[0]`, but the routing table entry on the right, for the host `bsd` itself, points to the loopback structure. Since `rt_ifp.if_output` (Figure 8.25) points to the output routine, packets sent to the local IP address are routed to the loopback interface.
6. Each routing table entry also points to the corresponding `in_ifaddr` structure. (Actually the `rt_ifa` member points to an `ifaddr` structure, but recall from Figure 6.8 that the first member of an `in_ifaddr` structure is an `ifaddr` structure.) We show only one of these pointers in the figure, although all four point to the same structure. Remember that a single interface, say `le0`, can have multiple IP addresses, each with its own `in_ifaddr` structure, which is why the `rt_ifa` pointer is required in addition to the `rt_ifp` pointer.

See the text (Figure 6.8) for the structure of `ifaddr`, and we have removed the labels 3 and 6.

7. The `la_hold` member is a pointer to an mbuf chain. An ARP request is broadcast because a datagram is sent to that IP address. While the kernel awaits the ARP reply it holds onto the mbuf chain for the datagram by storing its address in `la_hold`. When the ARP reply is received, the mbuf chain pointed to by `la_hold` is sent.
8. Finally, we show the variable `rmx_expire`, which is in the `rt_metrics` structure within the routing table entry. This value is the timer associated with each ARP entry. Some time after an ARP entry has been created (normally 20 minutes) the ARP entry is deleted.

Even though major routing table changes took place with 4.3BSD Reno, the ARP cache was left alone with 4.3BSD Reno and Net/2. 4.4BSD, however, removed the stand-alone ARP cache and moved the ARP information into the routing table.

The ARP table in Net/2 was an array of structures composed of the following members: an IP address, an Ethernet address, a timer, flags, and a pointer to an mbuf (similar to the `la_hold` member in Figure 21.1). We see with Net/3 that the same information is now spread throughout multiple structures, all of which are linked.

### 21.3 Code Introduction

There are nine ARP functions in a single C file and definitions in two headers, as shown in Figure 21.2.

File	Description
<code>net/if_arp.h</code>	<code>arpdr</code> structure definition
<code>netinet/if_ether.h</code>	various structure and constant definitions
<code>netinet/if_ether.c</code>	ARP functions

Figure 21.2 Files discussed in this chapter.

Figure 21.3 shows the relationship of the ARP functions to other kernel functions. In this figure we also show the relationship between the ARP functions and some of the routing functions from Chapter 19. We describe all these relationships as we proceed through the chapter.

#### Global Variables

Ten global variables are introduced in this chapter, which are shown in Figure 21.4.

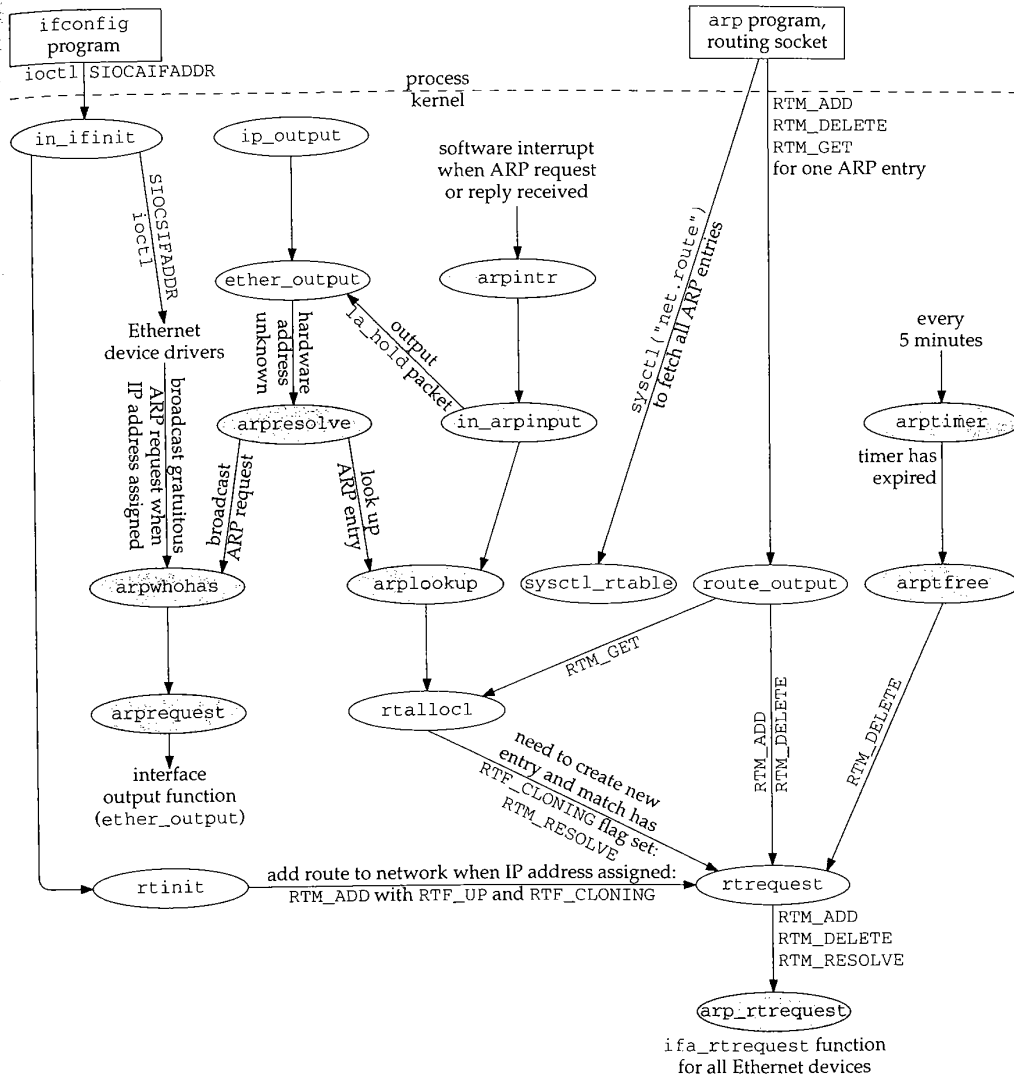

Figure 21.3 Relationship of ARP functions to rest of kernel.

Variable	Datatype	Description
llinfo_arp	struct llinfo_arp	head of llinfo_arp doubly linked list (Figure 21.1)
arpintrq	struct ifqueue	ARP input queue from Ethernet device drivers (Figure 4.9)
arpt_prune	int	#seconds between checking ARP list ( $5 \times 60$ )
arpt_keep	int	#seconds ARP entry valid once resolved ( $20 \times 60$ )
arpt_down	int	#seconds between ARP flooding algorithm (20)
arp_inuse	int	#ARP entries currently in use
arp_allocated	int	#ARP entries ever allocated
arp_maxtries	int	max #tries for an IP address before pausing (5)
arpinit_done	int	initialization-performed flag
useloopback	int	use loopback for local host (default true)

Figure 21.4 Global variables introduced in this chapter.

### Statistics

The only statistics maintained by ARP are the two globals `arp_inuse` and `arp_allocated`, from Figure 21.4. The former counts the number of ARP entries currently in use and the latter counts the total number of ARP entries allocated since the system was initialized. Neither counter is output by the `netstat` program, but they can be examined with a debugger.

The entire ARP cache can be listed using the `arp -a` command, which uses the `sysctl` system call with the arguments shown in Figure 19.36. Figure 21.5 shows the output from this command, for the entries shown in Figure 18.2.

```
bsd1 $ arp -a
sun.tuc.noao.edu (140.252.13.33) at 8:0:20:3:f6:42
svr4.tuc.noao.edu (140.252.13.34) at 0:0:c0:c2:9b:26
bsd1.tuc.noao.edu (140.252.13.35) at 0:0:c0:6f:2d:40 permanent
ALL-SYSTEMS.MCAST.NET (224.0.0.1) at (incomplete)
```

Figure 21.5 `arp -a` output corresponding to Figure 18.2.

Since the multicast group 224.0.0.1 has the L flag set in Figure 18.2, and since the `arp` program looks for entries with the `RTF_LLINFO` flag set, the multicast groups are output by the program. Later in this chapter we'll see why this entry is marked as "incomplete" and why the entry above it is "permanent."

### SNMP Variables

As described in Section 25.8 of Volume 1, the original SNMP MIB defined an address translation group that was the system's ARP cache. MIB-II deprecated this group and instead each network protocol group (i.e., IP) contains its own address translation tables. Notice that the change in Net/2 to Net/3 from a stand-alone ARP table to an integration of the ARP information within the IP routing table parallels this SNMP change.

Figure 21.6 shows the IP address translation table from MIB-II, named `ipNetToMediaTable`. The values returned by SNMP for this table are taken from the routing table entry and its corresponding `ifnet` structure.

IP address translation table, index = < <code>ipNetToMediaIfIndex</code> > . < <code>ipNetToMediaNetAddress</code> >		
Name	Member	Description
<code>ipNetToMediaIfIndex</code>	<code>if_index</code>	corresponding interface: <code>ifIndex</code>
<code>ipNetToMediaPhysAddress</code>	<code>rt_gateway</code>	physical address
<code>ipNetToMediaNetAddress</code>	<code>rt_key</code>	IP address
<code>ipNetToMediaType</code>	<code>rt_flags</code>	type of mapping: 1 = other, 2 = invalidated, 3 = dynamic, 4 = static (see text)

Figure 21.6 IP address translation table: `ipNetToMediaTable`.

If the routing table entry has an expiration time of 0 it is considered permanent and hence "static." Otherwise the entry is considered "dynamic."

## 21.4 ARP Structures

Figure 21.7 shows the format of an ARP packet when transmitted on an Ethernet.

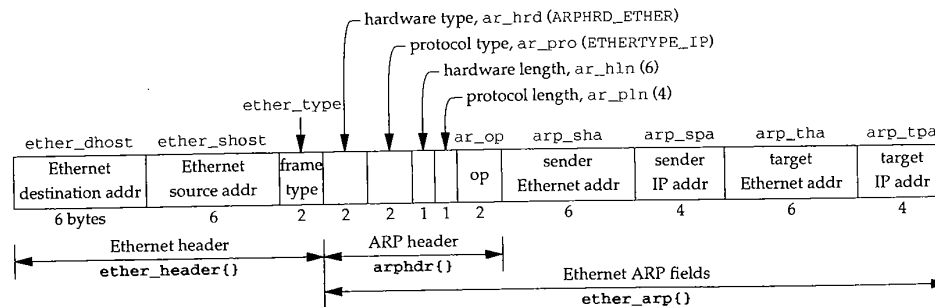

Figure 21.7 Format of an ARP request or reply when used on an Ethernet.

The `ether_header` structure (Figure 4.10) defines the 14-byte Ethernet header; the `arphdr` structure defines the next five fields, which are common to ARP requests and ARP replies on any type of media; and the `ether_arp` structure combines the `arphdr` structure with the sender and target addresses when ARP is used on an Ethernet.

Figure 21.8 shows the definition of the `arphdr` structure. Figure 21.7 shows the values of the first four fields in this structure when ARP is mapping IP addresses to Ethernet addresses.

Figure 21.9 shows the combination of the `arphdr` structure with the fields used with IP addresses and Ethernet addresses, forming the `ether_arp` structure. Notice that ARP uses the terms *hardware* to describe the 48-bit Ethernet address, and *protocol* to describe the 32-bit IP address.

use and  
tries cur-  
since the  
, but they

uses the  
shows the

ce the arp  
ps are out-  
as "incom-

an address  
group and  
translation  
table to an  
this SNMP

```

-----if_arp.h
45 struct arphdr {
46     u_short ar_hrd;           /* format of hardware address */
47     u_short ar_pro;         /* format of protocol address */
48     u_char ar_hln;          /* length of hardware address */
49     u_char ar_pln;          /* length of protocol address */
50     u_short ar_op;          /* ARP/RARP operation, Figure 21.15 */
51 };
-----if_arp.h

```

Figure 21.8 arphdr structure: common ARP request/reply header.

```

-----if_ether.h
79 struct ether_arp {
80     struct arphdr ea_hdr;     /* fixed-size header */
81     u_char arp_sha[6];       /* sender hardware address */
82     u_char arp_spa[4];       /* sender protocol address */
83     u_char arp_tha[6];       /* target hardware address */
84     u_char arp_tpa[4];       /* target protocol address */
85 };

86 #define arp_hrd ea_hdr.ar_hrd
87 #define arp_pro ea_hdr.ar_pro
88 #define arp_hln ea_hdr.ar_hln
89 #define arp_pln ea_hdr.ar_pln
90 #define arp_op ea_hdr.ar_op
-----if_ether.h

```

Figure 21.9 ether\_arp structure.

One `llinfo_arp` structure, shown in Figure 21.10, exists for each ARP entry. Additionally, one of these structures is allocated as a global of the same name and used as the head of the linked list of all these structures. We often refer to this list as the *ARP cache*, since it is the only data structure in Figure 21.1 that has a one-to-one correspondence with the ARP entries.

```

-----if_ether.h
103 struct llinfo_arp {
104     struct llinfo_arp *la_next;
105     struct llinfo_arp *la_prev;
106     struct rtentry *la_rt;
107     struct mbuf *la_hold;     /* last packet until resolved/timeout */
108     long la_asked;           /* #times we've queried for this addr */
109 };

110 #define la_timer la_rt->rt_rmx.rmx_expire /* deletion time in seconds */
-----if_ether.h

```

Figure 21.10 llinfo\_arp structure.

With Net/2 and earlier systems it was easy to identify the structure called the *ARP cache*, since a single structure contained everything for each ARP entry. Since Net/3 stores the ARP information among multiple structures, no single structure can be called the *ARP cache*. Nevertheless, having the concept of an ARP cache, which is the collection of information describing a single ARP entry, simplifies the discussion.

104-106 The first two entries form the doubly linked list, which is updated by the `insque` and `remque` functions. `la_rt` points to the associated routing table entry, and the `rt_llinfo` member of the routing table entry points to this structure.

107 When ARP receives an IP datagram to send to another host but the destination's hardware address is not in the ARP cache, an ARP request must be sent and the ARP reply received before the datagram can be sent. While waiting for the reply the `mbuf` pointer to the datagram is saved in `la_hold`. When the ARP reply is received, the packet pointed to by `la_hold` (if any) is sent.

108-109 `la_asked` counts how many consecutive times an ARP request has been sent to this IP address without receiving a reply. We'll see in Figure 21.24 that when this counter reaches a limit, that host is considered down and another ARP request won't be sent for a while.

110 This definition uses the `rmx_expire` member of the `rt_metrics` structure in the routing table entry as the ARP timer. When the value is 0, the ARP entry is considered permanent. When nonzero, the value is the number of seconds since the Unix Epoch when the entry expires.

## 21.5 arpwhoas Function

The `arpwhoas` function is normally called by `arpresolve` to broadcast an ARP request. It is also called by each Ethernet device driver to issue a *gratuitous ARP* request when the IP address is assigned to the interface (the `SIOCSIFADDR ioctl` in Figure 6.28). Section 4.7 of Volume 1 describes gratuitous ARP—it detects if another host on the Ethernet is using the same IP address and also allows other hosts with ARP entries for this host to update their ARP entry if this host has changed its Ethernet address. `arpwhoas` simply calls `arprequest`, shown in the next section, with the correct arguments.

```

196 void
197 arpwhoas(ac, addr)
198 struct arpcom *ac;
199 struct in_addr *addr;
200 {
201     arprequest(ac, &ac->ac_ipaddr.s_addr, &addr->s_addr, ac->ac_enaddr);
202 }

```

if\_ether.c

if\_ether.c

Figure 21.11 `arpwhoas` function: broadcast an ARP request.

196-202 The `arpcom` structure (Figure 3.26) is common to all Ethernet devices and is part of the `le_softc` structure, for example (Figure 3.20). The `ac_ipaddr` member is a copy of the interface's IP address, which is set by the driver when the `SIOCSIFADDR ioctl` is executed (Figure 6.28). `ac_enaddr` is the Ethernet address of the device.

The second argument to this function, `addr`, is the IP address for which the ARP request is being issued: the target IP address. In the case of a gratuitous ARP request, `addr` equals `ac_ipaddr`, so the second and third arguments to `arprequest` are the same, which means the sender IP address will equal the target IP address in the gratuitous ARP request.

## 21.6 arprequest Function

The `arprequest` function is called by `arpwhoas` to broadcast an ARP request. It builds an ARP request packet and passes it to the interface's output function.

Before looking at the source code, let's examine the data structures built by the function. To send the ARP request the interface output function for the Ethernet device (`ether_output`) is called. One argument to `ether_output` is an mbuf containing the data to send: everything that follows the Ethernet type field in Figure 21.7. Another argument is a socket address structure containing the destination address. Normally this destination address is an IP address (e.g., when `ip_output` calls `ether_output` in Figure 21.3). For the special case of an ARP request, the `sa_family` member of the socket address structure is set to `AF_UNSPEC`, which tells `ether_output` that it contains a filled-in Ethernet header, including the destination Ethernet address. This prevents `ether_output` from calling `arpresolve`, which would cause an infinite loop. We don't show this loop in Figure 21.3, but the "interface output function" below `arprequest` is `ether_output`. If `ether_output` were to call `arpresolve` again, the infinite loop would occur.

Figure 21.12 shows the mbuf and the socket address structure built by this function. We also show the two pointers `eh` and `ea`, which are used in the function.

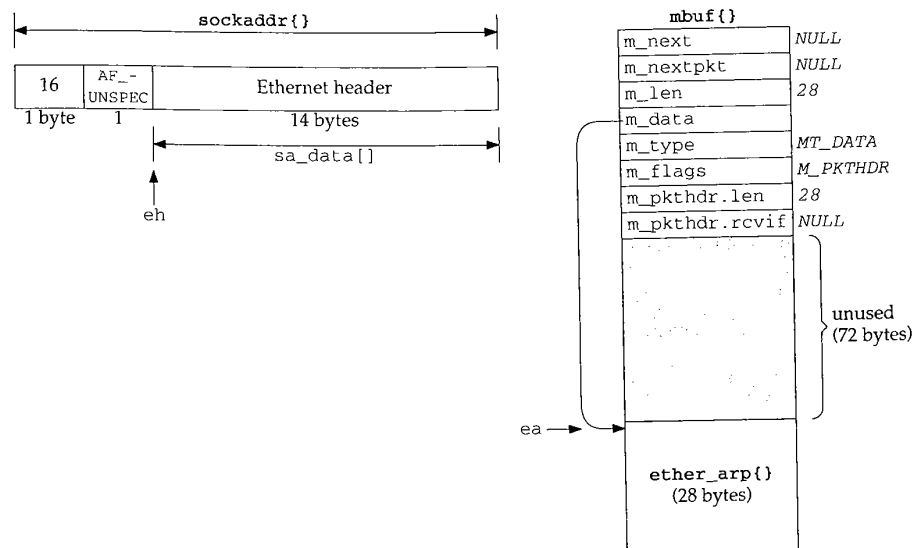

Figure 21.12 `sockaddr` and `mbuf` built by `arprequest`.

Figure 21.13 shows the `arprequest` function.



```

209 static void
210 arprequest(ac, sip, tip, enaddr)
211 struct arpcom *ac;
212 u_long *sip, *tip;
213 u_char *enaddr;
214 {
215     struct mbuf *m;
216     struct ether_header *eh;
217     struct ether_arp *ea;
218     struct sockaddr sa;

219     if ((m = m_gethdr(M_DONTWAIT, MT_DATA)) == NULL)
220         return;
221     m->m_len = sizeof(*ea);
222     m->m_pkthdr.len = sizeof(*ea);
223     MH_ALIGN(m, sizeof(*ea));

224     ea = mtod(m, struct ether_arp *);
225     eh = (struct ether_header *) sa.sa_data;
226     bzero((caddr_t) ea, sizeof(*ea));

227     bcopy((caddr_t) etherbroadcastaddr, (caddr_t) eh->ether_dhost,
228           sizeof(eh->ether_dhost));
229     eh->ether_type = ETHERTYPE_ARP;    /* if_output() will swap */

230     ea->arp_hrd = htons(ARPHRD_ETHER);
231     ea->arp_pro = htons(ETHERTYPE_IP);
232     ea->arp_hln = sizeof(ea->arp_sha); /* hardware address length */
233     ea->arp_pln = sizeof(ea->arp_spa); /* protocol address length */
234     ea->arp_op = htons(ARPOP_REQUEST);
235     bcopy((caddr_t) enaddr, (caddr_t) ea->arp_sha, sizeof(ea->arp_sha));
236     bcopy((caddr_t) sip, (caddr_t) ea->arp_spa, sizeof(ea->arp_spa));
237     bcopy((caddr_t) tip, (caddr_t) ea->arp_tpa, sizeof(ea->arp_tpa));

238     sa.sa_family = AF_UNSPEC;
239     sa.sa_len = sizeof(sa);

240     (*ac->ac_if.if_output) (&ac->ac_if, m, &sa, (struct rentry *) 0);
241 }

```

Figure 21.13 arprequest function: build an ARP request packet and send it.

#### Allocate and initialize mbuf

209-223 A packet header mbuf is allocated and the two length fields are set. MH\_ALIGN allows room for a 28-byte ether\_arp structure at the end of the mbuf, and sets the m\_data pointer accordingly. The reason for moving this structure to the end of the mbuf is to allow ether\_output to prepend the 14-byte Ethernet header in the same mbuf.

**Initialize pointers**

224-226 The two pointers `ea` and `eh` are set and the `ether_arp` structure is set to 0. The only purpose of the call to `bzero` is to set the target hardware address to 0, because the other eight fields in this structure are explicitly set to their respective value.

**Fill in Ethernet header**

227-229 The destination Ethernet address is set to the Ethernet broadcast address and the Ethernet type field is set to `ETHERTYPE_ARP`. Note the comment that this 2-byte field will be converted from host byte order to network byte order by the interface output function. This function also fills in the Ethernet source address field. Figure 21.14 shows the different values for the Ethernet type field.

Constant	Value	Description
<code>ETHERTYPE_IP</code>	0x0800	IP frames
<code>ETHERTYPE_ARP</code>	0x0806	ARP frames
<code>ETHERTYPE_REVARP</code>	0x8035	reverse ARP (RARP) frames
<code>ETHERTYPE_IPTRAILERS</code>	0x1000	trailer encapsulation (deprecated)

Figure 21.14 Ethernet type fields.

RARP maps an Ethernet address to an IP address and is used when a diskless system bootstraps. RARP is normally not part of the kernel's implementation of TCP/IP, so it is not covered in this text. Chapter 5 of Volume 1 describes RARP.

**Fill in ARP fields**

230-237 All fields in the `ether_arp` structure are filled in, except the target hardware address, which is what the ARP request is looking for. The constant `ARPHRD_ETHER`, which has a value of 1, specifies the format of the hardware addresses as 6-byte Ethernet addresses. To identify the protocol addresses as 4-byte IP addresses, `arp_pro` is set to the Ethernet type field for IP from Figure 21.14. Figure 21.15 shows the various ARP operation codes. We encounter the first two in this chapter. The last two are used with RARP.

Constant	Value	Description
<code>ARPOP_REQUEST</code>	1	ARP request to resolve protocol address
<code>ARPOP_REPLY</code>	2	reply to ARP request
<code>ARPOP_REVREQUEST</code>	3	RARP request to resolve hardware address
<code>ARPOP_REVREPLY</code>	4	reply to RARP request

Figure 21.15 ARP operation codes.

**Fill in `sockaddr` and call interface output function**

238-241 The `sa_family` member of the socket address structure is set to `AF_UNSPEC` and the `sa_len` member is set to 16. The interface output function is called, which we said is `ether_output`.

## 21.7 arpintr Function

In Figure 4.13 we saw that when `ether_input` receives an Ethernet frame with a type field of `ETHERTYPE_ARP`, it schedules a software interrupt of priority `NETISR_ARP` and appends the frame to ARP's input queue: `arpintrq`. When the kernel processes the software interrupt, the function `arpintr`, shown in Figure 21.16, is called.

— `if_ether.c`

```

319 void
320 arpintr()
321 {
322     struct mbuf *m;
323     struct arphdr *ar;
324     int s;

325     while (arpintrq.ifq_head) {
326         s = splimp();
327         IF_DEQUEUE(&arpintrq, m);
328         splx(s);
329         if (m == 0 || (m->m_flags & M_PKTHDR) == 0)
330             panic("arpintr");

331         if (m->m_len >= sizeof(struct arphdr) &&
332             (ar = mtod(m, struct arphdr *)) &&
333             ntohs(ar->ar_hrd) == ARPHRD_ETHER &&
334             m->m_len >= sizeof(struct arphdr) + 2*ar->ar_hln + 2*ar->ar_pln)

335             switch (ntohs(ar->ar_pro)) {
336                 case ETHERTYPE_IP:
337                 case ETHERTYPE_IPTRAILERS:
338                     in_arpinput(m);
339                     continue;
340             }

341         m_freem(m);
342     }
343 }

```

— `if_ether.c`

Figure 21.16 `arpintr` function: process Ethernet frames containing ARP requests or replies.

319-343 The `while` loop processes one frame at a time, as long as there are frames on the queue. The frame is processed if the hardware type specifies Ethernet addresses, and if the size of the frame is greater than or equal to the size of an `arphdr` structure plus the sizes of two hardware addresses and two protocol addresses. If the type of protocol addresses is either `ETHERTYPE_IP` or `ETHERTYPE_IPTRAILERS`, the `in_arpinput` function, shown in the next section, is called. Otherwise the frame is discarded.

Notice the order of the tests within the `if` statement. The length is checked twice. First, if the length is at least the size of an `arphdr` structure, then the fields in that structure can be examined. The length is checked again, using the two length fields in the `arphdr` structure.

## 21.8 in\_arpinput Function

This function is called by `arpintr` to process each received ARP request or ARP reply. While ARP is conceptually simple, numerous rules add complexity to the implementation. The following two scenarios are typical:

1. If a request is received for one of the host's IP addresses, a reply is sent. This is the normal case of some other host on the Ethernet wanting to send this host a packet. Also, since we're about to receive a packet from that other host, and we'll probably send a reply, an ARP entry is created for that host (if one doesn't already exist) because we have its IP address and hardware address. This optimization avoids another ARP exchange when the packet is received from the other host.
2. If a reply is received in response to a request sent by this host, the corresponding ARP entry is now complete (the hardware address is known). The other host's hardware address is stored in the `sockaddr_dl` structure and any queued packet for that host can now be sent. Again, this is the normal case.

ARP requests are normally broadcast so each host sees *all* ARP requests on the Ethernet, even those requests for which it is not the target. Recall from `arprequest` that when a request is sent, it contains the *sender's* IP address and hardware address. This allows the following tests also to occur.

3. If some other host sends a request or reply with a sender IP address that equals this host's IP address, one of the two hosts is misconfigured. Net/3 detects this error and logs a message for the administrator. (We say "request or reply" here because `in_arpinput` doesn't examine the operation type. But ARP replies are normally unicast, in which case only the target host of the reply receives the reply.)
4. If this host receives a request or reply from some other host for which an ARP entry already exists, and if the other host's hardware address has changed, the hardware address in the ARP entry is updated accordingly. This can happen if the other host is shut down and then rebooted with a different Ethernet interface (hence a different hardware address) before its ARP entry times out. The use of this technique, along with the other host sending a gratuitous ARP request when it reboots, prevents this host from being unable to communicate with the other host after the reboot because of an ARP entry that is no longer valid.
5. This host can be configured as a *proxy ARP server*. This means it responds to ARP requests for some other host, supplying the other host's hardware address in the reply. The host whose hardware address is supplied in the proxy ARP reply must be one that is able to forward IP datagrams to the host that is the target of the ARP request. Section 4.6 of Volume 1 discusses proxy ARP.

A Net/3 system can be configured as a proxy ARP server. These ARP entries are added with the `arp` command, specifying the IP address, hardware address,

358-37

376-38

and the keyword `pub`. We'll see the support for this in Figure 21.20 and we describe it in Section 21.12.

We examine `in_arpinput` in four parts. Figure 21.17 shows the first part.

```

358 static void
359 in_arpinput(m)
360 struct mbuf *m;
361 {
362     struct ether_arp *ea;
363     struct arpcom *ac = (struct arpcom *) m->m_pkthdr.rcvif;
364     struct ether_header *eh;
365     struct llinfo_arp *la = 0;
366     struct rtenry *rt;
367     struct in_ifaddr *ia, *maybe_ia = 0;
368     struct sockaddr_dl *sdl;
369     struct sockaddr sa;
370     struct in_addr isaddr, itaddr, myaddr;
371     int op;

372     ea = mtod(m, struct ether_arp *);
373     op = ntohs(ea->arp_op);
374     bcopy((caddr_t) ea->arp_spa, (caddr_t) &isaddr, sizeof(isaddr));
375     bcopy((caddr_t) ea->arp_tpa, (caddr_t) &itaddr, sizeof(itaddr));

376     for (ia = in_ifaddr; ia; ia = ia->ia_next)
377         if (ia->ia_ifp == &ac->ac_if) {
378             maybe_ia = ia;
379             if ((itaddr.s_addr == ia->ia_addr.sin_addr.s_addr) ||
380                 (isaddr.s_addr == ia->ia_addr.sin_addr.s_addr))
381                 break;
382         }
383     if (maybe_ia == 0)
384         goto out;
385     myaddr = ia ? ia->ia_addr.sin_addr : maybe_ia->ia_addr.sin_addr;

```

Figure 21.17 `in_arpinput` function: look for matching interface.

358-375 The length of the `ether_arp` structure was verified by the caller, so `ea` is set to point to the received packet. The ARP operation (request or reply) is copied into `op` but it isn't examined until later in the function. The sender's IP address and target IP address are copied into `isaddr` and `itaddr`.

#### Look for matching interface and IP address

376-382 The linked list of Internet addresses for the host is scanned (the list of `in_ifaddr` structures, Figure 6.5). Remember that a given interface can have multiple IP addresses. Since the received packet contains a pointer (in the `mbuf` packet header) to the receiving interface's `ifnet` structure, the only IP addresses considered in the `for` loop are those associated with the receiving interface. If either the target IP address or the sender's IP address matches one of the IP addresses for the receiving interface, the `break` terminates the loop.

383-384 If the loop terminates with the variable `maybe_ia` equal to 0, the entire list of configured IP addresses was searched and not one was associated with the received interface. The function jumps to `out` (Figure 21.19), where the mbuf is discarded and the function returns. This should only happen if an ARP request is received on an interface that has been initialized but has not been assigned an IP address.

385 If the `for` loop terminates having located a receiving interface (`maybe_ia` is non-null) but none of its IP addresses matched the sender or target IP address, `myaddr` is set to the final IP address assigned to the interface. Otherwise (the normal case) `myaddr` contains the local IP address that matched either the sender or target IP address.

Figure 21.18 shows the next part of the `in_arpinput` function, which performs some validation of the packet.

```

386     if (!bcmp((caddr_t) ea->arp_sha, (caddr_t) ac->ac_enaddr,
387              sizeof(ea->arp_sha)))
388         goto out;          /* it's from me, ignore it. */
389     if (!bcmp((caddr_t) ea->arp_sha, (caddr_t) etherbroadcastaddr,
390              sizeof(ea->arp_sha))) {
391         log(LOG_ERR,
392            "arp: ether address is broadcast for IP address %x!\n",
393            ntohl(isaddr.s_addr));
394         goto out;
395     }
396     if (isaddr.s_addr == myaddr.s_addr) {
397         log(LOG_ERR,
398            "duplicate IP address %x!! sent from ethernet address: %s\n",
399            ntohl(isaddr.s_addr), ether_sprintf(ea->arp_sha));
400         itaddr = myaddr;
401         goto reply;
402     }

```

if\_ether.c

if\_ether.c

Figure 21.18 `in_arpinput` function: validate received packet.

#### Validate sender's hardware address

386-388 If the sender's hardware address equals the hardware address of the interface, the host received a copy of its own request, which is ignored.

389-395 If the sender's hardware address is the Ethernet broadcast address, this is an error. The error is logged and the packet is discarded.

#### Check sender's IP address

396-402 If the sender's IP address equals `myaddr`, then the sender is using the same IP address as this host. This is also an error—probably a configuration error by the system administrator on either this host or the sending host. The error is logged and the function jumps to `reply` (Figure 21.19), after setting the target IP address to `myaddr` (the duplicate address). Notice that this ARP packet could have been destined for some other host on the Ethernet—it need not have been sent to this host. Nevertheless, if this form of IP address spoofing is detected, the error is logged and a reply generated.

Figure 21.19 shows the next part of `in_arpinput`.

of con-  
inter-  
nd the  
erface

s non-  
is set  
/addr

forms

\_ether.c

```

-----if_ether.c
403 la = arplookup(isaddr.s_addr, itaddr.s_addr == myaddr.s_addr, 0);
404 if (la && (rt = la->la_rt) && (sdl = SDL(rt->rt_gateway))) {
405     if (sdl->sdl_alen &&
406         bcmp((caddr_t) ea->arp_sha, LLADDR(sdl), sdl->sdl_alen))
407         log(LOG_INFO, "arp info overwritten for %x by %s\n",
408             isaddr.s_addr, ether_sprintf(ea->arp_sha));
409     bcopy((caddr_t) ea->arp_sha, LLADDR(sdl),
410          sdl->sdl_alen = sizeof(ea->arp_sha));
411     if (rt->rt_expire)
412         rt->rt_expire = time.tv_sec + arpt_keep;
413     rt->rt_flags &= ~RTF_REJECT;
414     la->la_asked = 0;
415     if (la->la_hold) {
416         (*ac->ac_if.if_output) (&ac->ac_if, la->la_hold,
417                               rt_key(rt), rt);
418         la->la_hold = 0;
419     }
420 }

421 reply:
422 if (op != ARPOP_REQUEST) {
423     out:
424     m_freem(m);
425     return;
426 }
-----if_ether.c

```

Figure 21.19 in\_arpinput function: create a new ARP entry or update existing entry.

**Search routing table for match with sender's IP address**

\_ether.c

403 arplookup searches the ARP cache for the sender's IP address (isaddr). The second argument is 1 if the target IP address equals myaddr (meaning create a new entry if an entry doesn't exist), or 0 otherwise (do not create a new entry). An entry is always created for the sender if this host is the target; otherwise the host is processing a broadcast intended for some other target, so it just looks for an existing entry for the sender. As mentioned earlier, this means that if a host receives an ARP request for itself from another host, an ARP entry is created for that other host on the assumption that, since that host is about to send us a packet, we'll probably send a reply.

ie, the  
error.

The third argument is 0, which means do not look for a proxy ARP entry (described later). The return value is a pointer to an llinfo\_arp structure, or a null pointer if an entry is not found or created.

**Update existing entry or fill in new entry**

ne IP  
system  
func-  
r (the  
some  
if this

404 The code associated with the if statement is executed only if the following three conditions are all true:

1. an ARP entry was found or a new ARP entry was successfully created (la is nonnull),
2. the ARP entry points to a routing table entry (rt), and

3. the `rt_gateway` field of the routing table entry points to a `sockaddr_dl` structure.

The first condition is false for every broadcast ARP request not directed to this host, from some other host whose IP address is not currently in the routing table.

#### Check if sender's hardware addresses changed

405-408 If the link-level address length (`sdl_alen`) is nonzero (meaning that an existing entry is being referenced and not a new entry that was just created), the link-level address is compared to the sender's hardware address. If they are different, the sender's Ethernet address has changed. This can happen if the sending host is shut down, its Ethernet interface card replaced, and it reboots before the ARP entry times out. While not common, this is a possibility that must be handled. An informational message is logged and the code continues, which will update the hardware address with its new value.

The sender's IP address in the log message should be converted to host byte order. This is a bug.

#### Record sender's hardware address

409-410 The sender's hardware address is copied into the `sockaddr_dl` structure pointed to by the `rt_gateway` member of the routing table entry. The link-level address length (`sdl_alen`) in the `sockaddr_dl` structure is also set to 6. This assignment of the length field is required if this is a newly created entry (Exercise 21.3).

#### Update newly resolved ARP entry

411-412 When the sender's hardware address is resolved, the following steps occur. If the expiration time is nonzero, it is reset to 20 minutes (`arpt_keep`) in the future. This test exists because the `arp` command can create permanent entries: entries that never time out. These entries are marked with an expiration time of 0. We'll also see in Figure 21.24 that when an ARP request is sent (i.e., for a nonpermanent ARP entry) the expiration time is set to the current time, which is nonzero.

413-414 The `RTF_REJECT` flag is cleared and the `la_asked` counter is set to 0. We'll see that these last two steps are used in `arpresolve` to avoid ARP flooding.

415-420 If ARP is holding onto an mbuf awaiting ARP resolution of that host's hardware address (the `la_hold` pointer), the mbuf is passed to the interface output function. (We show this in Figure 21.3.) Since this mbuf was being held by ARP, the destination address must be on a local Ethernet so the interface output function is `ether_output`. This function again calls `arpresolve`, but the hardware address was just filled in, allowing the mbuf to be queued on the actual device's output queue.

#### Finished with ARP reply packets

421-426 If the ARP operation is not a request, the received packet is discarded and the function returns.

The remainder of the function, shown in Figure 21.20, generates a reply to an ARP request. A reply is generated in only two instances:



1. this host is the target of a request for its hardware address, or
2. this host receives a request for another host's hardware address for which this host has been configured to act as an ARP proxy server.

At this point in the function, an ARP request has been received, but since ARP requests are normally broadcast, the request could be for any system on the Ethernet.

```

427     if (itaddr.s_addr == myaddr.s_addr) {
428         /* I am the target */
429         bcopy((caddr_t) ea->arp_sha, (caddr_t) ea->arp_tha,
430             sizeof(ea->arp_sha));
431         bcopy((caddr_t) ac->ac_enaddr, (caddr_t) ea->arp_sha,
432             sizeof(ea->arp_sha));
433     } else {
434         la = arplookup(itaddr.s_addr, 0, SIN_PROXY);
435         if (la == NULL)
436             goto out;
437         rt = la->la_rt;
438         bcopy((caddr_t) ea->arp_sha, (caddr_t) ea->arp_tha,
439             sizeof(ea->arp_sha));
440         sdl = SDL(rt->rt_gateway);
441         bcopy(LLADDR(sdl), (caddr_t) ea->arp_sha, sizeof(ea->arp_sha));
442     }

443     bcopy((caddr_t) ea->arp_spa, (caddr_t) ea->arp_tpa, sizeof(ea->arp_spa));
444     bcopy((caddr_t) &itaddr, (caddr_t) ea->arp_spa, sizeof(ea->arp_spa));
445     ea->arp_op = htons(ARPOP_REPLY);
446     ea->arp_pro = htons(ETHERTYPE_IP); /* let's be sure! */
447     eh = (struct ether_header *) sa.sa_data;
448     bcopy((caddr_t) ea->arp_tha, (caddr_t) eh->ether_dhost,
449         sizeof(eh->ether_dhost));
450     eh->ether_type = ETHERTYPE_ARP;
451     sa.sa_family = AF_UNSPEC;
452     sa.sa_len = sizeof(sa);
453     (*ac->ac_if.if_output) (&ac->ac_if, m, &sa, (struct rentry *) 0);
454     return;
455 }

```

Figure 21.20 in\_arpinput function: form ARP reply and send it.

#### This host is the target

427-432 If the target IP address equals myaddr, this host is the target of the request. The source hardware address is copied into the target hardware address (i.e., whoever sent it becomes the target) and the Ethernet address of the interface is copied from the arpcom structure into the source hardware address. The remainder of the ARP reply is constructed after the else clause.

#### Check if this host is a proxy server for target

433-436 Even if this host is not the target, this host can be configured to be a proxy server for the specified target. arplookup is called again with the create flag set to 0 (the second

argument) and the third argument set to `SIN_PROXY`. This finds an entry in the routing table only if that entry's `SIN_PROXY` flag is set. If an entry is not found (the typical case where this host receives a copy of some other ARP request on the Ethernet), the code at out discards the mbuf and returns.

#### Form proxy reply

437-442 To handle a proxy ARP request, the sender's hardware address becomes the target hardware address and the Ethernet address from the ARP entry is copied into the sender hardware address field. This value from the ARP entry can be the Ethernet address of any host on the Ethernet capable of sending IP datagrams to the target IP address. Normally the host providing the proxy ARP service supplies its own Ethernet address, but that's not required. Proxy entries are created by the system administrator using the `arp` command, with the keyword `pub`, specifying the target IP address (which becomes the key of the routing table entry) and an Ethernet address to return in the ARP reply.

#### Complete construction of ARP reply packet

443-444 The remainder of the function completes the construction of the ARP reply. The sender and target hardware addresses have been filled in. The sender and target IP addresses are now swapped. The target IP address is contained in `itaddr`, which might have been changed if another host was found using this host's IP address (Figure 21.18).

445-446 The ARP operation is set to `ARPOP_REPLY` and the type of protocol address is set to `ETHERTYPE_IP`. The comment "let's be sure!" is because `arpintr` also calls this function when the type of protocol address is `ETHERTYPE_IPTRAILERS`, but the use of trailer encapsulation is no longer supported.

#### Fill in `sockaddr` with Ethernet header

447-452 A `sockaddr` structure is filled in with the 14-byte Ethernet header, as shown in Figure 21.12. The target hardware address also becomes the Ethernet destination address.

453-455 The ARP reply is passed to the interface's output routine and the function returns.

## 21.9 ARP Timer Functions

467- ARP entries are normally dynamic—they are created when needed and time out automatically. It is also possible for the system administrator to create permanent entries (i.e., no timeout), and the proxy entries we discussed in the previous section are always permanent. Recall from Figure 21.1 and the `#define` at the end of Figure 21.10 that the `rmx_expire` member of the routing metrics structure is used by ARP as a timer.

#### `arptimer` Function

This function, shown in Figure 21.21, is called every 5 minutes. It goes through all the ARP entries to see if any have expired.

```

74 static void
75 arptimer(ignored_arg)
76 void *ignored_arg;
77 {
78     int s = splnet();
79     struct llinfo_arp *la = llinfo_arp.la_next;
80     timeout(arptimer, (caddr_t) 0, arpt_prune * hz);
81     while (la != &llinfo_arp) {
82         struct rtentry *rt = la->la_rt;
83         la = la->la_next;
84         if (rt->rt_expire && rt->rt_expire <= time.tv_sec)
85             arptfree(la->la_prev); /* timer has expired, clear */
86     }
87     splx(s);
88 }

```

Figure 21.21 arptimer function: check all ARP timers every 5 minutes.

#### Set next timeout

80 We'll see that the `arp_rtrequest` function causes `arptimer` to be called the first time, and from that point `arptimer` causes itself to be called 5 minutes (`arpt_prune`) in the future.

#### Check all ARP entries

81-86 Each entry in the linked list is processed. If the timer is nonzero (it is not a permanent entry) and if the timer has expired, `arptfree` releases the entry. If `rt_expire` is nonzero, it contains a count of the number of seconds since the Unix Epoch when the entry expires.

#### arptfree Function

This function, shown in Figure 21.22, is called by `arptimer` to delete a single entry from the linked list of `llinfo_arp` entries.

#### Invalidate (don't delete) entries in use

467-473 If the routing table reference count is greater than 0 and the `rt_gateway` member points to a `sockaddr_dl` structure, `arptfree` takes the following steps:

1. the link-layer address length is set to 0,
2. the `la_asked` counter is reset to 0, and
3. the `RTF_REJECT` flag is cleared.

The function then returns. Since the reference count is nonzero, the routing table entry is not deleted. But setting `sdl_alen` to 0 invalidates the entry, so the next time the entry is used, an ARP request will be generated.

```

459 static void
460 arptfree(la)
461 struct llinfo_arp *la;
462 {
463     struct rtable *rt = la->la_rt;
464     struct sockaddr_dl *sdl;
465     if (rt == 0)
466         panic("arptfree");
467     if (rt->rt_refcnt > 0 && (sdl = SDL(rt->rt_gateway)) &&
468         sdl->sdl_family == AF_LINK) {
469         sdl->sdl_alen = 0;
470         la->la_asked = 0;
471         rt->rt_flags &= ~RTF_REJECT;
472         return;
473     }
474     rtrequest(RTM_DELETE, rt_key(rt), (struct sockaddr *) 0, rt_mask(rt),
475             0, (struct rtable **) 0);
476 }

```

Figure 21.22 arptfree function: delete or invalidate an ARP entry.

#### Delete unreferenced entries

474-475 rtrequest deletes the routing table entry, and we'll see in Section 21.13 that it calls arptfree. This latter function frees any mbuf chain held by the ARP entry (the la\_hold pointer) and deletes the corresponding llinfo\_arp entry.

## 21.10 arpresolve Function

We saw in Figure 4.16 that ether\_output calls arpresolve to obtain the Ethernet address for an IP address. arpresolve returns 1 if the destination Ethernet address is known, allowing ether\_output to queue the IP datagram on the interface's output queue. A return value of 0 means arpresolve does not know the Ethernet address. The datagram is "held" by arpresolve (using the la\_hold member of the llinfo\_arp structure) and an ARP request is sent. If and when an ARP reply is received, in\_arpinput completes the ARP entry and sends the held datagram.

arpresolve must also avoid *ARP flooding*, that is, it must not repeatedly send ARP requests at a high rate when an ARP reply is not received. This can happen when several datagrams are sent to the same unresolved IP address before an ARP reply is received, or when a datagram destined for an unresolved address is fragmented, since each fragment is sent to ether\_output as a separate packet. Section 11.9 of Volume 1 contains an example of ARP flooding caused by fragmentation, and discusses the associated problems. Figure 21.23 shows the first half of arpresolve.

252-261 dst is a pointer to a sockaddr\_in containing the destination IP address and desten is an array of 6 bytes that is filled in with the corresponding Ethernet address, if known.

```

252 int
253 arpresolve(ac, rt, m, dst, desten)
254 struct arpcom *ac;
255 struct rtbody *rt;
256 struct mbuf *m;
257 struct sockaddr *dst;
258 u_char *desten;
259 {
260     struct llinfo_arp *la;
261     struct sockaddr_dl *sdl;
262     if (m->m_flags & M_BCAST) { /* broadcast */
263         bcopy((caddr_t) etherbroadcastaddr, (caddr_t) desten,
264             sizeof(etherbroadcastaddr));
265         return (1);
266     }
267     if (m->m_flags & M_MCAST) { /* multicast */
268         ETHER_MAP_IP_MULTICAST(&SIN(dst)->sin_addr, desten);
269         return (1);
270     }
271     if (rt)
272         la = (struct llinfo_arp *) rt->rt_llinfo;
273     else {
274         if (la = arplookup(SIN(dst)->sin_addr.s_addr, 1, 0))
275             rt = la->la_rt;
276     }
277     if (la == 0 || rt == 0) {
278         log(LOG_DEBUG, "arpresolve: can't allocate llinfo");
279         m_freem(m);
280         return (0);
281     }

```

Figure 21.23 arpresolve function: find ARP entry if required.

#### Handle broadcast and multicast destinations

262-270 If the `M_BCAST` flag of the `mbuf` is set, the destination is filled in with the Ethernet broadcast address and the function returns 1. If the `M_MCAST` flag is set, the `ETHER_MAP_IP_MULTICAST` macro (Figure 12.6) converts the class D address into the corresponding Ethernet address.

#### Get pointer to `llinfo_arp` structure

271-276 The destination address is a unicast address. If a pointer to a routing table entry is passed by the caller, `la` is set to the corresponding `llinfo_arp` structure. Otherwise `arplookup` searches the routing table for the specified IP address. The second argument is 1, telling `arplookup` to create the entry if it doesn't already exist; the third argument is 0, which means don't look for a proxy ARP entry.

277-281 If either `rt` or `la` are null pointers, one of the allocations failed, since `arplookup` should have created an entry if one didn't exist. An error message is logged, the packet released, and the function returns 0.

Figure 21.24 contains the last half of `arpresolve`. It checks whether the ARP entry is still valid, and, if not, sends an ARP request.

```

282     sdl = SDL(rt->rt_gateway);
283     /*
284     * Check the address family and length is valid, the address
285     * is resolved; otherwise, try to resolve.
286     */
287     if ((rt->rt_expire == 0 || rt->rt_expire > time.tv_sec) &&
288         sdl->sdl_family == AF_LINK && sdl->sdl_alen != 0) {
289         bcopy(LLADDR(sdl), desten, sdl->sdl_alen);
290         return 1;
291     }
292     /*
293     * There is an arptab entry, but no ethernet address
294     * response yet. Replace the held mbuf with this
295     * latest one.
296     */
297     if (la->la_hold)
298         m_freem(la->la_hold);
299     la->la_hold = m;

300     if (rt->rt_expire) {
301         rt->rt_flags &= ~RTF_REJECT;
302         if (la->la_asked == 0 || rt->rt_expire != time.tv_sec) {
303             rt->rt_expire = time.tv_sec;
304             if (la->la_asked++ < arp_maxtries)
305                 arpwhoas(ac, &(SIN(dst)->sin_addr));
306             else {
307                 rt->rt_flags |= RTF_REJECT;
308                 rt->rt_expire += arpt_down;
309                 la->la_asked = 0;
310             }
311         }
312     }
313     return (0);
314 }

```

*if\_ether.c*

Figure 21.24 `arpresolve` function: check if ARP entry valid, send ARP request if not.

#### Check ARP entry for validity

282-291 Even though an ARP entry is located, it must be checked for validity. The entry is valid if the following conditions are all true:

1. the entry is permanent (the expiration time is 0) or the expiration time is greater than the current time, and
2. the family of the socket address structure pointed to by `rt_gateway` is `AF_LINK`, and
3. the link-level address length (`sdl_alen`) is nonzero.

Recall that `arpfree` invalidated an ARP entry that was still referenced by setting `sdl_alen` to 0. If the entry is valid, the Ethernet address contained in the `sockaddr_dl` is copied into `desten` and the function returns 1.

#### Hold only most recent IP datagram

292-299 At this point an ARP entry exists but it does not contain a valid Ethernet address. An ARP request must be sent. First the pointer to the mbuf chain is saved in `la_hold`, after releasing any mbuf chain that was already pointed to by `la_hold`. This means that if multiple IP datagrams are sent quickly to a given destination, and an ARP entry does not already exist for the destination, during the time it takes to send an ARP request and receive a reply only the *last* datagram is held, and all prior ones are discarded. An example that generates this condition is NFS. If NFS sends an 8500-byte IP datagram that is fragmented into six IP fragments, and if all six fragments are sent by `ip_output` to `ether_output` in the time it takes to send an ARP request and receive a reply, the first five fragments are discarded and only the final fragment is sent when the reply is received. This in turn causes an NFS timeout, and a retransmission of all six fragments.

#### Send ARP request but avoid ARP flooding

300-314 RFC 1122 requires ARP to avoid sending ARP requests to a given destination at a high rate when a reply is not received. The technique used by Net/3 to avoid ARP flooding is as follows.

- Net/3 never sends more than one ARP request in any given second to a destination.
- If a reply is not received after five ARP requests (i.e., after about 5 seconds), the `RTF_REJECT` flag in the routing table is set and the expiration time is set for 20 seconds in the future. This causes `ether_output` to refuse to send IP datagrams to this destination for 20 seconds, returning `EHOSTDOWN` or `EHOSTUNREACH` instead (Figure 4.15).
- After the 20-second pause in ARP requests, `arpresolve` will send ARP requests to that destination again.

If the expiration time is nonzero (i.e., this is not a permanent entry) the `RTF_REJECT` flag is cleared, in case it had been set earlier to avoid flooding. The counter `la_asked` counts the number of consecutive times an ARP request has been sent to this destination. If the counter is 0 or if the expiration time does not equal the current time (looking only at the seconds portion of the current time), an ARP request might be sent. This comparison avoids sending more than one ARP request during any second. The expiration time is then set to the current time in seconds (i.e., the microseconds portion, `time.tv_usec` is ignored).

The counter is compared to the limit of 5 (`arp_maxtries`) and then incremented. If the value was less than 5, `arpwhoas` sends the request. If the request equals 5, however, ARP has reached its limit: the `RTF_REJECT` flag is set, the expiration time is set to 20 seconds in the future, and the counter `la_asked` is reset to 0.

Figure 21.25 shows an example to explain further the algorithm used by `arpresolve` and `ether_output` to avoid ARP flooding.

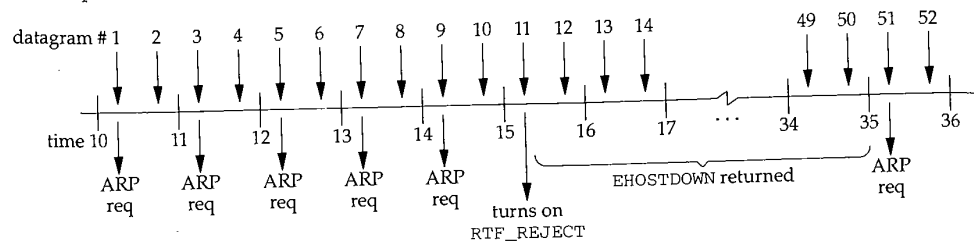

Figure 21.25 Algorithm used to avoid ARP flooding.

We show 26 seconds of time, labeled 10 through 36. We assume a process is sending an IP datagram every one-half second, causing two datagrams to be sent every second. The datagrams are numbered 1 through 52. We also assume that the destination host is down, so there are no replies to the ARP requests. The following actions take place:

- We assume `la_asked` is 0 when datagram 1 is written by the process. `la_hold` is set to point to datagram 1, `rt_expire` is set to the current time (10), `la_asked` becomes 1, and an ARP request is sent. The function returns 0.
- When datagram 2 is written by the process, datagram 1 is discarded and `la_hold` is set to point to datagram 2. Since `rt_expire` equals the current time (10), nothing else happens (an ARP request is not sent) and the function returns 0.
- When datagram 3 is written, datagram 2 is discarded and `la_hold` is set to point to datagram 3. The current time (11) does not equal `rt_expire` (10), so `rt_expire` is set to 11. `la_asked` is less than 5, so `la_asked` becomes 2 and an ARP request is sent.
- When datagram 4 is written, datagram 3 is discarded and `la_hold` is set to point to datagram 4. Since `rt_expire` equals the current time (11), nothing else happens and the function returns 0.
- Similar actions occur for datagrams 5 through 10. After datagram 9 causes an ARP request to be sent, `la_asked` is 5.
- When datagram 11 is written, datagram 10 is discarded and `la_hold` is set to point to datagram 11. The current time (15) does not equal `rt_expire` (14), so `rt_expire` is set to 15. `la_asked` is no longer less than 5, so the ARP flooding avoidance algorithm takes place: `RTF_REJECT` flag is set, `rt_expire` is set to 35 (20 seconds in the future), and `la_asked` is reset to 0. The function returns 0.
- When datagram 12 is written, `ether_output` notices that the `RTF_REJECT` flag is set and that the current time is less than `rt_expire` (35) causing `EHOSTDOWN` to be returned to the sender (normally `ip_output`).
- The `EHOSTDOWN` error is returned for datagrams 13 through 50.

21.1

111-



- When datagram 51 is written, even though the RTF\_REJECT flag is set ether\_output does not return the error because the current time (35) is no longer less than rt\_expire (35). arpresolve is called and the entire process starts over again: five ARP requests are sent in 5 seconds, followed by a 20-second pause. This continues until the sending process gives up or the destination host responds to an ARP request.

### 21.11 arplookup Function

arplookup calls the routing function rtable to look up an ARP entry in the Internet routing table. We've seen three calls to arplookup:

1. from in\_arpinput to look up and possibly create an entry corresponding to the source IP address of a received ARP packet,
2. from in\_arpinput to see if a proxy ARP entry exists for the destination IP address of a received ARP request, and
3. from arpresolve to look up or create an entry corresponding to the destination IP address of a datagram that is about to be sent.

If arplookup succeeds, a pointer is returned to the corresponding llinfo\_arp structure; otherwise a null pointer is returned.

arplookup has three arguments. The first is the IP address to search for, the second is a flag that is true if a new entry should be created if the entry is not found, and the third is a flag that is true if a proxy ARP entry should be searched for and possibly created.

Proxy ARP entries are handled by defining a different form of the Internet socket address structure, a sockaddr\_inarp structure, shown in Figure 21.26 This structure is used only by ARP.

```

-----if_ether.h
111 struct sockaddr_inarp {
112     u_char  sin_len;           /* sizeof(struct sockaddr_inarp) = 16 */
113     u_char  sin_family;       /* AF_INET */
114     u_short sin_port;
115     struct in_addr sin_addr;  /* IP address */
116     struct in_addr sin_srcaddr; /* not used */
117     u_short sin_tos;         /* not used */
118     u_short sin_other;       /* 0 or SIN_PROXY */
119 };
-----if_ether.h

```

Figure 21.26 sockaddr\_inarp structure.

111-119 The first 8 bytes are the same as a sockaddr\_in structure and the sin\_family is also set to AF\_INET. The final 8 bytes, however, are different: the sin\_srcaddr, sin\_tos, and sin\_other members. Of these three, only the final one is used, being set to SIN\_PROXY (1) if the entry is a proxy entry.

Figure 21.27 shows the `arplookup` function.

```

480 static struct llinfo_arp *
481 arplookup(addr, create, proxy)
482 u_long addr;
483 int create, proxy;
484 {
485     struct rtable *rt;
486     static struct sockaddr_inarp sin =
487     (sizeof(sin), AF_INET);
488     sin.sin_addr.s_addr = addr;
489     sin.sin_other = proxy ? SIN_PROXY : 0;
490     rt = rtalloc1((struct sockaddr *) &sin, create);
491     if (rt == 0)
492         return (0);
493     rt->rt_refcnt--;
494     if ((rt->rt_flags & RTF_GATEWAY) || (rt->rt_flags & RTF_LLIINFO) == 0 ||
495         rt->rt_gateway->sa_family != AF_LINK) {
496         if (create)
497             log(LOG_DEBUG, "arptnew failed on %x\n", ntohl(addr));
498         return (0);
499     }
500     return ((struct llinfo_arp *) rt->rt_llinfo);
501 }

```

Figure 21.27 `arplookup` function: look up an ARP entry in the routing table.

#### Initialize `sockaddr_inarp` to look up

480-489 The `sin_addr` member is set to the IP address that is being looked up. The `sin_other` member is set to `SIN_PROXY` if the `proxy` argument is nonzero, or 0 otherwise.

#### Look up entry in routing table

490-492 `rtalloc1` looks up the IP address in the Internet routing table, creating a new entry if the `create` argument is nonzero. If the entry is not found, the function returns 0 (a null pointer).

#### Decrement routing table reference count

493 If the entry is found, the reference count for the routing table entry is decremented. This is because ARP is not considered to "hold onto" a routing table entry like the transport layers, so the increment of `rt_refcnt` that was done by the routing table lookup is undone here by ARP.

494-499 If the `RTF_GATEWAY` flag is set, or the `RTF_LLIINFO` flag is not set, or the address family of the socket address structure pointed to by `rt_gateway` is not `AF_LINK`, something is wrong and a null pointer is returned. If the entry was created this way, a log message is created.

The log message with the function name `arptnew` refers to the older Net/2 function that created ARP entries.

If `rtalloc1` creates a new entry because the matching entry had the `RTF_CLONING` flag set, the function `arp_rtrequest` (which we describe in Section 21.13) is also called by `rtrequest`.

## 21.12 Proxy ARP

Net/3 supports proxy ARP, as we saw in the previous section. Two different types of proxy ARP entries can be added to the routing table. Both are added with the `arp` command, specifying the `pub` option. Adding a proxy ARP entry always causes a gratuitous ARP request to be issued by `arp_rtrequest` (Figure 21.28) because the `RTF_ANNOUNCE` flag is set when the entry is created.

The first type of proxy ARP entry allows an IP address for a host on an attached network to be entered into the ARP cache. Any Ethernet address can be assigned to the entry. These entries are added to the routing table with an explicit mask of `0xffffffff`. The purpose of this mask is to allow the call to `rtalloc1` in Figure 21.27 to match this entry, even if the `SIN_PROXY` flag is set in the socket address structure of the search key. This in turn allows the call to `arplookup` from Figure 21.20 to match this entry when a search is made for the target address with the `SIN_PROXY` flag set.

This type of entry can be used if a host H1 that doesn't implement ARP is on an attached network. The host with the proxy entry answers all ARP requests for H1's hardware address, supplying the Ethernet address that was specified when the proxy entry was created (i.e., the Ethernet address of H1). These entries are output with the notation "published" by the `arp -a` command.

The second type of proxy ARP entry is for a host for which a routing table entry already exists. The kernel creates another routing table entry for the destination, with this new entry containing the link-layer information (i.e., the Ethernet address). The `SIN_PROXY` flag is set in the `sin_other` member of the `sockaddr_inarp` structure (Figure 21.26) in the new routing table entry. Recall that routing table searches compare 12 bytes of the Internet socket address structure (Figure 18.39). This use of the `SIN_PROXY` flag is the only time the final 8 bytes of the structure are nonzero. When `arplookup` specifies the `SIN_PROXY` value in the `sin_other` member of the structure passed to `rtalloc1`, the only entries in the routing table that will match are ones that also have the `SIN_PROXY` flag set.

This type of entry normally specifies the Ethernet address of the host acting as the proxy server. If the proxy entry was created for a host HD, the sequence of steps is as follows.

1. The proxy server receives a broadcast ARP request for HD's hardware address from some other host HS. The host HS thinks HD is on the local network.
2. The proxy server responds, supplying its own Ethernet address.
3. HS sends the datagram with a destination IP address of HD to the proxy server's Ethernet address.

4. The proxy server receives the datagram for HD and forwards it, using the normal routing table entry for HD.

This type of entry was used on the router netb in the example in Section 4.6 of Volume 1. These entries are output by the `arp -a` command with the notation “published (proxy only).”

### 21.13 `arp_rtrequest` Function

Figure 21.3 provides an overview of the relationship between the ARP functions and the routing functions. We’ve encountered two calls to the routing table functions from the ARP functions.

1. `arplookup` calls `rtalloc1` to look up an ARP entry and possibly create a new entry if a match isn’t found.

If a matching entry is found in the routing table and the `RTF_CLONING` flag is not set (i.e., it is a matching entry for the destination host), the pointer to the matching entry is returned. But if the `RTF_CLONING` bit is set, `rtalloc1` calls `rtrequest` with a command of `RTM_RESOLVE`. This is how the entries for 140.252.13.33 and 140.252.13.34 in Figure 18.2 were created—they were cloned from the entry for 140.252.13.32.

2. `arpfree` calls `rtrequest` with a command of `RTM_DELETE` to delete an entry from the routing table that corresponds to an ARP entry.

Additionally, the `arp` command manipulates the ARP cache by sending and receiving routing messages on a routing socket. The `arp` command issues routing messages with commands of `RTM_ADD`, `RTM_DELETE`, and `RTM_GET`. The first two commands cause `rtrequest` to be called and the third causes `rtalloc1` to be called.

Finally, when an Ethernet device driver has an IP address assigned to the interface, `rtinit` adds a route to the network. This causes `rtrequest` to be called with a command of `RTM_ADD` and with the flags of `RTF_UP` and `RTF_CLONING`. This is how the entry for 140.252.13.32 in Figure 18.2 was created.

As described in Chapter 19, each `ifaddr` structure can contain a pointer to a function (the `ifa_rtrequest` member) that is automatically called when a routing table entry is added or deleted for that interface. We saw in Figure 6.17 that `in_ifinit` sets this pointer to the function `arp_rtrequest` for all Ethernet devices. Therefore, whenever the routing functions are called to add or delete a routing table entry for ARP, `arp_rtrequest` is also called. The purpose of this function is to do whatever type of initialization or cleanup is required above and beyond what the generic routing table functions perform. For example, this is where a new `llinfo_arp` structure is allocated and initialized whenever a new ARP entry is created. In a similar way, the `llinfo_arp` structure is deleted by this function after the generic routing routines have completed processing an `RTM_DELETE` command.

Figure 21.28 shows the first part of the `arp_rtrequest` function.

```

92 void
93 arp_rtrequest(req, rt, sa)
94 int req;
95 struct rtable *rt;
96 struct sockaddr *sa;
97 {
98     struct sockaddr *gate = rt->rt_gateway;
99     struct llinfo_arp *la = (struct llinfo_arp *) rt->rt_llinfo;
100     static struct sockaddr_dl null_sdl =
101         (sizeof(null_sdl), AF_LINK);

102     if (!arpinit_done) {
103         arpinit_done = 1;
104         timeout(arptimer, (caddr_t) 0, hz);
105     }
106     if (rt->rt_flags & RTF_GATEWAY)
107         return;
108     switch (req) {

109     case RTM_ADD:
110         /*
111          * XXX: If this is a manually added route to interface
112          * such as older version of routed or gated might provide,
113          * restore cloning bit.
114          */
115         if ((rt->rt_flags & RTF_HOST) == 0 &&
116             SIN(rt_mask(rt))->sin_addr.s_addr != 0xffffffff)
117             rt->rt_flags |= RTF_CLONING;
118         if (rt->rt_flags & RTF_CLONING) {
119             /*
120              * Case 1: This route should come from a route to iface.
121              */
122             rt_setgate(rt, rt_key(rt),
123                 (struct sockaddr *) &null_sdl);
124             gate = rt->rt_gateway;
125             SDL(gate)->sdl_type = rt->rt_ifp->if_type;
126             SDL(gate)->sdl_index = rt->rt_ifp->if_index;
127             rt->rt_expire = time.tv_sec;
128             break;
129         }
130         /* Announce a new entry if requested. */
131         if (rt->rt_flags & RTF_ANNOUNCE)
132             arprequest((struct arpcmd *) rt->rt_ifp,
133                 &SIN(rt_key(rt))->sin_addr.s_addr,
134                 &SIN(rt_key(rt))->sin_addr.s_addr,
135                 (u_char *) LLADDR(SDL(gate)));
136         /* FALLTHROUGH */

```

Figure 21.28 `arp_rtrequest` function: RTM\_ADD command.

**Initialize ARP timeout function**

92-105 The first time `arp_rtrequest` is called (when the first Ethernet interface is assigned an IP address during system initialization), the `timeout` function schedules the function `arptimer` to be called in 1 second. This starts the ARP timer code running every 5 minutes, since `arptimer` always calls `timeout`. 130-135

**Ignore indirect routes**

106-107 If the `RTF_GATEWAY` flag is set, the function returns. This flag indicates an indirect routing table entry and all ARP entries are direct routes. 136

108 The remainder of the function is a switch with three cases: `RTM_ADD`, `RTM_RESOLVE`, and `RTM_DELETE`. (The latter two are shown in figures that follow.)

**RTM\_ADD command**

109 The first case for `RTM_ADD` is invoked by either the `arp` command manually creating an ARP entry or by an Ethernet interface being assigned an IP address by `rtinit` (Figure 21.3).

**Backward compatibility**

110-117 If the `RTF_HOST` flag is cleared, this routing table entry has an associated mask (i.e., it is a network route, not a host route). If that mask is not all one bits, then the entry is really a route to an interface, so the `RTF_CLONING` flag is set. As the comment indicates, this is for backward compatibility with older versions of some routing daemons. Also, the command 145-146

```
route add -net 224.0.0.0 -interface bsd1
```

that is in the file `/etc/netstart` creates the entry for this network shown in Figure 18.2 that has the `RTF_CLONING` flag set.

**Initialize entry for network route to interface**

118-126 If the `RTF_CLONING` flag is set (which `in_ifinit` sets for all Ethernet interfaces), this entry is probably being added by `rtinit`. `rt_setgate` allocates space for a `sockaddr_dl` structure, which is pointed to by the `rt_gateway` member. This data-link socket address structure is the one associated with the routing table entry for 140.252.13.32 in Figure 21.1. The `sdl_len` and `sdl_family` members are initialized from the static definition of `null_sdl` at the beginning of the function, and the `sdl_type` (probably `IPT_ETHER`) and `sdl_index` members are copied from the interface's `ifnet` structure. This structure never contains an Ethernet address and the `sdl_alen` member remains 0. 147-151

127-128 Finally, the expiration time is set to the current time, which is simply the time the entry was created, and the `break` causes the function to return. For entries created at system initialization, their `rmx_expire` value is the time at which the system was bootstrapped. Notice in Figure 21.1 that this routing table entry does not have an associated `llinfo_arp` structure, so it is never processed by `arptimer`. Nevertheless this `sockaddr_dl` structure is used: since it is the `rt_gateway` structure for the entry that is cloned for host-specific entries on this Ethernet, it is copied by `rtrequest` when the newly cloned entries are created with the `RTM_RESOLVE` command. Also, the `netstat` program prints the `sdl_index` value as `link#n`, as we see in Figure 18.2. 159-161

### Send gratuitous ARP request

130-135 If the `RTF_ANNOUNCE` flag is set, this entry is being created by the `arp` command with the `pub` option. This option has two ramifications: (1) the `SIN_PROXY` flag will be set in the `sin_other` member of the `sockaddr_inarp` structure, and (2) the `RTF_ANNOUNCE` flag will be set. Since the `RTF_ANNOUNCE` flag is set, `arprequest` broadcasts a gratuitous ARP request. Notice that the second and third arguments are the same, which causes the sender IP address to equal the target IP address in the ARP request.

136 The code falls through to the case for the `RTM_RESOLVE` command.

Figure 21.29 shows the next part of the `arp_rtrequest` function, which handles the `RTM_RESOLVE` command. This command is issued when `rtalloc1` matches an entry with the `RTF_CLONING` flag set and its second argument is nonzero (the `create` argument to `arplookup`). A new `llinfo_arp` structure must be allocated and initialized.

### Verify `sockaddr_dl` structure

137-144 The family and length of the `sockaddr_dl` structure pointed to by the `rt_gateway` pointer are verified. The interface type (probably `IFT_ETHER`) and index are then copied into the new `sockaddr_dl` structure.

### Handle route changes

145-146 Normally the routing table entry is new and does not point to an `llinfo_arp` structure. If the `la` pointer is nonnull, however, `arp_rtrequest` was called when a route changed for an existing routing table entry. Since the `llinfo_arp` structure is already allocated, the `break` causes the function to return.

### Initialize `llinfo_arp` structure

147-158 An `llinfo_arp` structure is allocated and its pointer is stored in the `rt_llinfo` pointer of the routing table entry. The two statistics `arp_inuse` and `arp_allocated` are incremented and the `llinfo_arp` structure is set to 0. This sets `la_hold` to a null pointer and `la_asked` to 0.

159-161 The `rt` pointer is stored in the `llinfo_arp` structure and the `RTF_LLINFO` flag is set. In Figure 18.2 we see that the three routing table entries created by ARP, 140.252.13.33, 140.252.13.34, and 140.252.13.35, all have the `L` flag enabled, as does the entry for 224.0.0.1. Recall that the `arp` program looks only for entries with this flag (Figure 19.36). Finally the new structure is added to the front of the linked list of `llinfo_arp` structures by `insque`.

The ARP entry has been created: `rtrequest` creates the routing table entry (often cloning a network-specific entry for the Ethernet) and `arp_rtrequest` allocates and initializes an `llinfo_arp` structure. All that remains is for an ARP request to be broadcast so that an ARP reply can fill in the host's Ethernet address. In the common sequence of events, `arp_rtrequest` is called because `arpresolve` called `arplookup` (the intermediate sequence of function calls can be followed in Figure 21.3). When control returns to `arpresolve`, it broadcasts the ARP request.

```

137     case RTM_RESOLVE:
138         if (gate->sa_family != AF_LINK ||
139             gate->sa_len < sizeof(null_sdl)) {
140             log(LOG_DEBUG, "arp_rtrequest: bad gateway value");
141             break;
142         }
143         SDL(gate)->sdl_type = rt->rt_ifp->if_type;
144         SDL(gate)->sdl_index = rt->rt_ifp->if_index;
145         if (la != 0)
146             break;          /* This happens on a route change */
147         /*
148         * Case 2: This route may come from cloning, or a manual route
149         * add with a LL address.
150         */
151         R_Malloc(la, struct llinfo_arp *, sizeof(*la));
152         rt->rt_llinfo = (caddr_t) la;
153         if (la == 0) {
154             log(LOG_DEBUG, "arp_rtrequest: malloc failed\n");
155             break;
156         }
157         arp_inuse++, arp_allocated++;
158         Bzero(la, sizeof(*la));
159
160         la->la_rt = rt;
161         rt->rt_flags |= RTF_LLINFO;
162         insque(la, &llinfo_arp);
163
164         if (SIN(rt_key(rt))->sin_addr.s_addr ==
165             (IA_SIN(rt->rt_ifa))->sin_addr.s_addr) {
166             /*
167             * This test used to be
168             * if (loif.if_flags & IFF_UP)
169             * It allowed local traffic to be forced
170             * through the hardware by configuring the loopback down.
171             * However, it causes problems during network configuration
172             * for boards that can't receive packets they send.
173             * It is now necessary to clear "useloopback" and remove
174             * the route to force traffic out to the hardware.
175             */
176             rt->rt_expire = 0;
177             Bcopy(((struct arpcom *) rt->rt_ifp)->ac_enaddr,
178                 LLADDR(SDL(gate)), SDL(gate)->sdl_alen = 6);
179             if (useloopback)
180                 rt->rt_ifp = &loif;
181         }
182     }
183     break;

```

Figure 21.29 arp\_rtrequest function: RTM\_RESOLVE command.



**Handle local host specially**

162-173 This portion of code is a special test that is new with 4.4BSD (although the comment is left over from earlier releases). It creates the rightmost routing table entry in Figure 21.1 with a key consisting of the local host's IP address (140.252.13.35). The `if` test checks whether the routing table key equals the IP address of the interface. If so, the entry that was just created (probably as a clone of the interface entry) refers to the local host.

**Make entry permanent and set Ethernet address**

174-176 The expiration time is set to 0, making the entry permanent—it will never time out. The Ethernet address is copied from the `arpcom` structure of the interface into the `sockaddr_dl` structure pointed to by the `rt_gateway` member.

**Set interface pointer to loopback interface**

177-178 If the global `uselookback` is nonzero (it defaults to 1), the interface pointer in the routing table entry is changed to point to the loopback interface. This means that any datagrams sent to the host's own IP address are sent to the loopback interface instead. Prior to 4.4BSD, the route from the host's own IP address to the loopback interface was established using a command of the form

```
route add 140.252.13.35 127.0.0.1
```

in the `/etc/netstart` file. Although this still works with 4.4BSD, it is unnecessary because the code we just looked at creates an equivalent route automatically, the first time an IP datagram is sent to the host's own IP address. Also realize that this piece of code is executed only once per interface. Once the routing table entry and the permanent ARP entry are created, they don't expire, so another `RTM_RESOLVE` for this IP address won't occur.

The final part of `arp_rtrequest`, shown in Figure 21.30, handles the `RTM_DELETE` request. From Figure 21.3 we see that this command can be generated from the `arp` command, to delete an entry manually, and from the `arpt free` function, when an ARP entry times out.

```

181     case RTM_DELETE:
182         if (la == 0)
183             break;
184         arp_inuse--;
185         remque(la);
186         rt->rt_llinfo = 0;
187         rt->rt_flags &= ~RTF_LLINFO;
188         if (la->la_hold)
189             m_freem(la->la_hold);
190         Free((caddr_t) la);
191     }
192 }

```

Figure 21.30 `arp_rtrequest` function: `RTM_DELETE` command.

**Verify 1a pointer**

182-183 The 1a pointer should always be nonnull (that is, the routing table entry should always point to an `llinfo_arp` structure); otherwise the break causes the function to return.

**Delete llinfo\_arp structure**

184-190 The `arp_inuse` statistic is decremented and the `llinfo_arp` structure is removed from the doubly linked list by `remque`. The `rt_llinfo` pointer is set to 0 and the `RTF_LLININFO` flag is cleared. If an mbuf is held by the ARP entry (i.e., an ARP request is outstanding), that mbuf is released. Finally the `llinfo_arp` structure is released.

Notice that the `switch` statement does not provide a default case and does not provide a case for the `RTM_GET` command. This is because the `RTM_GET` command issued by the `arp` program is handled entirely by the `route_output` function, and `rtrequest` is not called. Also, the call to `rtalloc1` that we show in Figure 21.3, which is caused by an `RTM_GET` command, specifies a second argument of 0; therefore `rtalloc1` does not call `rtrequest` in this case.

## 21.14 ARP and Multicasting

If an IP datagram is destined for a multicast group, `ip_output` checks whether the process has assigned a specific interface to the socket (Figure 12.40), and if so, the datagram is sent out that interface. Otherwise, `ip_output` selects the outgoing interface using the normal IP routing table (Figure 8.24). Therefore, on a system with more than one multicast-capable interface, the IP routing table specifies the default interface for each multicast group.

We saw in Figure 18.2 that an entry was created in our routing table for the 224.0.0.0 network and since that entry has its "clone" flag set, all multicast groups starting with 224 had the associated interface (1e0) as its default. Additional routing table entries can be created for the other multicast groups (the ones beginning with 225-239), or specific entries can be created for particular multicast groups to assign an explicit default. For example, a routing table entry could be created for 224.0.1.1 (the network time protocol) with an interface that differs from the interface for 224.0.0.0. If an entry for a multicast group does not exist in the routing table, and the process doesn't specify an interface with the `IP_MULTICAST_IF` socket option, the default interface for the group becomes the interface associated with the "default" route in the table. In Figure 18.2 the entry for 224.0.0.0 isn't really needed, since both it and the default route use the interface 1e0.

Once the interface is selected, if the interface is an Ethernet, `arpresolve` is called to convert the multicast group address into its corresponding Ethernet address. In Figure 21.23 this was done by invoking the macro `ETHER_MAP_IP_MULTICAST`. Since this simple macro logically ORs the low-order 23 bits of the multicast group with a constant (Figure 12.6), an ARP request-reply is not required and the mapping does not need to go into the ARP cache. The macro is just invoked each time the conversion is required.

Multicast group addresses appear in the Net/3 ARP cache if the multicast group is cloned from another entry, as we saw in Figure 21.5. This is because these entries have

the `RTF_LLINFO` flag set. These are not true ARP entries because they do not require an ARP request-reply, and they do not have an associated link-layer address, since the mapping is done when needed by the `ETHER_MAP_IP_MULTICAST` macro.

The timeout of the ARP entries for these multicast group addresses is different from normal ARP entries. When a routing table entry is created for a multicast group, such as the entry for 224.0.0.1 in Figure 18.2, `rtrequest` copies the `rt_metrics` structure from the entry being cloned (Figure 19.9). We mentioned with Figure 21.28 that the network entry has an `rmx_expire` value of the time the `RTM_ADD` command was executed, normally the time the system was initialized. The new entry for 224.0.0.1 has this same expiration time.

This means the ARP entry for a multicast group such as 224.0.0.1 expires the next time `arp_timer` executes, because its expiration time is always in the past. The entry is created again the next time it is looked up in the routing table.

## 21.15 Summary

ARP provides the dynamic mapping between IP addresses and hardware addresses. This chapter has examined an implementation of ARP that maps IP addresses to Ethernet addresses.

The Net/3 implementation is a major change from previous BSD releases. The ARP information is now stored in various structures: the routing table, a data-link socket address structure, and an `llinfo_arp` structure. Figure 21.1 shows the relationships between all the structures.

Sending an ARP request is simple: the appropriate fields are filled in and the request is sent as a broadcast. Processing a received request is more complicated because each host receives *all* broadcast ARP requests. Besides responding to requests for one of the host's IP addresses, `in_arpinput` also checks that some other host isn't using the host's IP address. Since all ARP requests contain the sender's IP and hardware addresses, any host on the Ethernet can use this information to update an existing ARP entry for the sender.

ARP flooding can be a problem on a LAN and Net/3 is the first BSD release to handle this. A maximum of one ARP request per second is sent to any given destination, and after five consecutive requests without a reply, a 20-second pause occurs before another ARP request is sent to that destination.

## Exercises

- 21.1 What assumption is made in the assignment of the local variable `ac` in Figure 21.17?
- 21.2 If we ping the broadcast address of the local Ethernet and then execute `arp -a`, we see that this causes the ARP cache to be filled with entries for almost every other host on the local Ethernet. Why?
- 21.3 Follow through the code and explain why the assignment of 6 to `sd1_alen` is required in Figure 21.19.

- 21.4 With the separate ARP table in Net/2, independent of the routing table, each time `arpresolve` was called, a search was made of the ARP table. Compare this to the Net/3 approach. Which is more efficient?
- 21.5 The ARP code in Net/2 explicitly set a timeout of 3 minutes for an incomplete entry in the ARP cache, that is, for an entry that is awaiting an ARP reply. We've never explicitly said how Net/3 handles this timeout. When does Net/3 time out an incomplete ARP entry?
- 21.6 What changes in the avoidance of ARP flooding when a Net/3 system is acting as a router and the packets that cause the flooding are from some other host?
- 21.7 What are the values of the four `rmx_expire` variables shown in Figure 21.1? Where in the code are the values set?
- 21.8 What change would be required to the code in this chapter to cause an ARP entry to be created for every host that broadcasts an ARP request?
- 21.9 To verify the example in Figure 21.25 the authors ran the `sock` program from Appendix C of Volume 1, writing a UDP datagram every 500 ms to a nonexistent host on the local Ethernet. (The `-p` option of the program was modified to allow millisecond waits.) But only 10 UDP datagrams were sent without an error, instead of the 11 shown in Figure 21.25, before the first `EHOSTDOWN` error was returned. Why?
- 21.10 Modify ARP to hold onto *all* packets for a destination, awaiting an ARP reply, instead of just the most recent one. What are the implications of this change? Should there be a limit, as there is for each interface's output queue? Are any changes required to the data structures?

22.1

# 22

## Protocol Control Blocks

### 22.1 Introduction

Protocol control blocks (PCBs) are used at the protocol layer to hold the various pieces of information required for each UDP or TCP socket. The Internet protocols maintain *Internet protocol control blocks* and *TCP control blocks*. Since UDP is connectionless, everything it needs for an end point is found in the Internet PCB; there are no UDP control blocks.

The Internet PCB contains the information common to all UDP and TCP end points: foreign and local IP addresses, foreign and local port numbers, IP header prototype, IP options to use for this end point, and a pointer to the routing table entry for the destination of this end point. The TCP control block contains all of the state information that TCP maintains for each connection: sequence numbers in both directions, window sizes, retransmission timers, and the like.

In this chapter we describe the Internet PCBs used in Net/3, saving TCP's control blocks until we describe TCP in detail. We examine the numerous functions that operate on Internet PCBs, since we'll encounter them when we describe UDP and TCP. Most of the functions begin with the six characters `in_pcb`.

Figure 22.1 summarizes the protocol control blocks that we describe and their relationship to the `file` and `socket` structures. There are numerous points to consider in this figure.

- When a socket is created by either `socket` or `accept`, the socket layer creates a `file` structure and a `socket` structure. The `file` type is `DTYPE_SOCKET` and the `socket` type is `SOCK_DGRAM` for UDP end points or `SOCK_STREAM` for TCP end points.

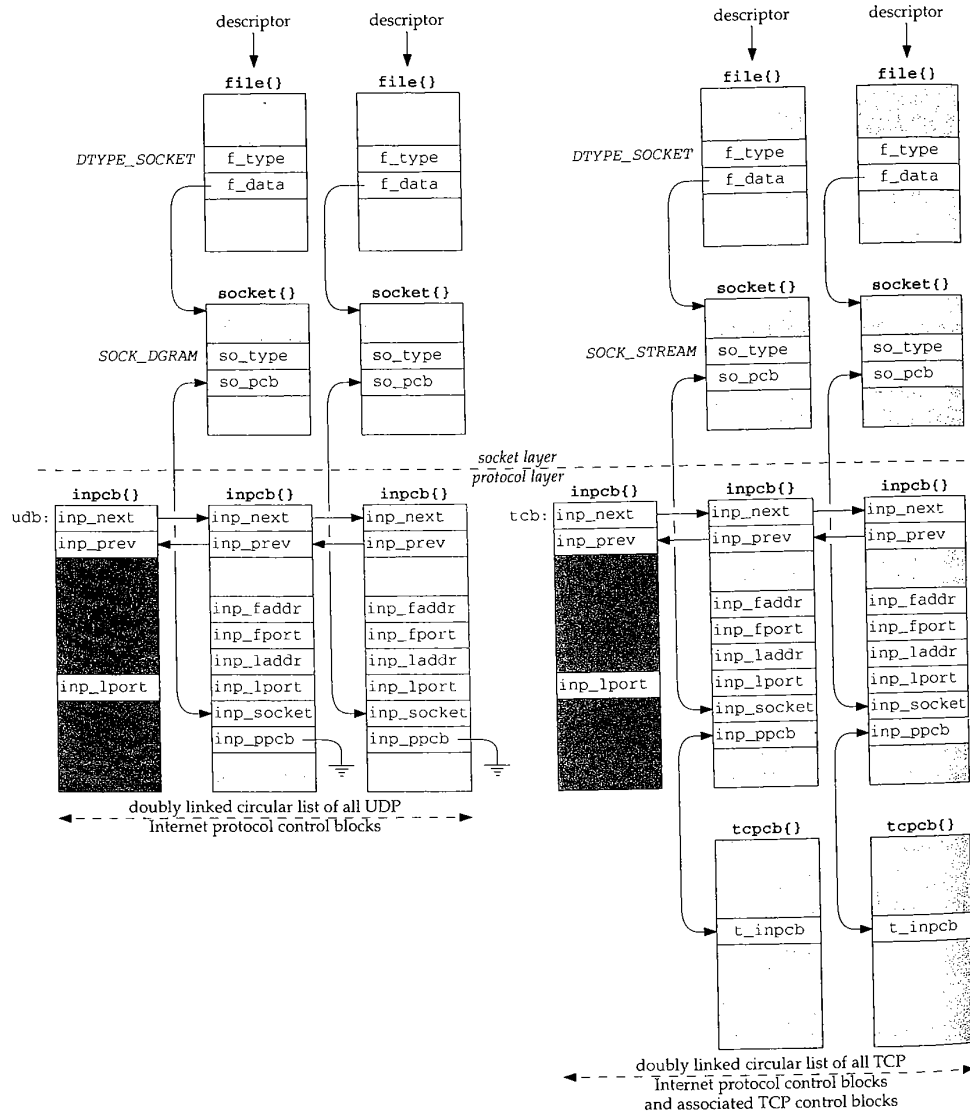

Figure 22.1 Internet protocol control blocks and their relationship to other structures.

- The protocol layer is then called. UDP creates an Internet PCB (an `inpcb` structure) and links it to the socket structure: the `so_pcb` member points to the `inpcb` structure and the `inp_socket` member points to the socket structure.
- TCP does the same and also creates its own control block (a `tcpcb` structure) and links it to the `inpcb` using the `inp_ppcb` and `t_inpcb` pointers. In the

two UDP `inpcb`s the `inp_ppcb` member is a null pointer, since UDP does not maintain its own control block.

- The four other members of the `inpcb` structure that we show, `inp_faddr` through `inp_lport`, form the socket pair for this end point: the foreign IP address and port number along with the local IP address and port number.
- Both UDP and TCP maintain a doubly linked list of all their Internet PCBs, using the `inp_next` and `inp_prev` pointers. They allocate a global `inpcb` structure as the head of their list (named `udb` and `tcb`) and only use three members in the structure: the next and previous pointers, and the local port number. This latter member contains the next ephemeral port number to use for this protocol.

The Internet PCB is a transport layer data structure. It is used by TCP, UDP, and raw IP, but not by IP, ICMP, or IGMP.

We haven't described raw IP yet, but it too uses Internet PCBs. Unlike TCP and UDP, raw IP does not use the port number members in the PCB, and raw IP uses only two of the functions that we describe in this chapter: `in_pcballoc` to allocate a PCB, and `in_pcbdetach` to release a PCB. We return to raw IP in Chapter 32.

## 22.2 Code Introduction

All the PCB functions are in a single C file and a single header contains the definitions, as shown in Figure 22.2.

File	Description
<code>netinet/in_pcb.h</code>	<code>inpcb</code> structure definition
<code>netinet/in_pcb.c</code>	PCB functions

Figure 22.2 Files discussed in this chapter.

### Global Variables

One global variable is introduced in this chapter, which is shown in Figure 22.3.

Variable	Datatype	Description
<code>zero_in_addr</code>	<code>struct in_addr</code>	32-bit IP address of all zero bits

Figure 22.3 Global variable introduced in this chapter.

### Statistics

Internet PCBs and TCP PCBs are both allocated by the kernel's `malloc` function with a type of `M_PCB`. This is just one of the approximately 60 different types of memory

allocated by the kernel. Mbufs, for example, are allocated with a type of `M_BUF`, and socket structures are allocated with a type of `M_SOCKET`.

Since the kernel can keep counters of the different types of memory buffers that are allocated, various statistics on the number of PCBs can be maintained. The command `vmstat -m` shows the kernel's memory allocation statistics and the `netstat -m` command shows the mbuf allocation statistics.

### 22.3 inpcb Structure

Figure 22.4 shows the definition of the `inpcb` structure. It is not a big structure, and occupies only 84 bytes.

```

42 struct inpcb {
43     struct inpcb *inp_next, *inp_prev; /* doubly linked list */
44     struct inpcb *inp_head; /* pointer back to chain of inpcb's for
45                             this protocol */
46     struct in_addr inp_faddr; /* foreign IP address */
47     u_short inp_fport; /* foreign port# */
48     struct in_addr inp_laddr; /* local IP address */
49     u_short inp_lport; /* local port# */
50     struct socket *inp_socket; /* back pointer to socket */
51     caddr_t inp_ppcb; /* pointer to per-protocol PCB */
52     struct route inp_route; /* placeholder for routing entry */
53     int inp_flags; /* generic IP/datagram flags */
54     struct ip inp_ip; /* header prototype; should have more */
55     struct mbuf *inp_options; /* IP options */
56     struct ip_options *inp_moptions; /* IP multicast options */
57 };

```

*in\_pcb.h*

*in\_pcb.h*

Figure 22.4 inpcb structure.

43-45 `inp_next` and `inp_prev` form the doubly linked list of all PCBs for UDP and TCP. Additionally, each PCB has a pointer to the head of the protocol's linked list (`inp_head`). For PCBs on the UDP list, `inp_head` always points to `udb` (Figure 22.1); for PCBs on the TCP list, this pointer always points to `tcb`.

46-49 The next four members, `inp_faddr`, `inp_fport`, `inp_laddr`, and `inp_lport`, contain the socket pair for this IP end point: the foreign IP address and port number and the local IP address and port number. These four values are maintained in the PCB in network byte order, not host byte order.

The Internet PCB is used by both transport layers, TCP and UDP. While it makes sense to store the local and foreign IP addresses in this structure, the port numbers really don't belong here. The definition of a port number and its size are specified by each transport layer and could differ between different transport layers. This problem was identified in [Partridge 1987], where 8-bit port numbers were used in version 1 of RDP, which required reimplementing several standard kernel routines to use 8-bit port numbers. Version 2 of RDP [Partridge and Hinden 1990] uses 16-bit port numbers. The port numbers really belong in a transport-specific control block, such as TCP's `tcpcb`. A new UDP-specific PCB would then be required. While doable, this would complicate some of the routines we'll examine shortly.



and  
it are  
nand  
com-

50-51 `inp_socket` is a pointer to the `socket` structure for this PCB and `inp_ppcb` is a pointer to an optional transport-specific control block for this PCB. We saw in Figure 22.1 that the `inp_ppcb` pointer is used with TCP to point to the corresponding `tcpcb`, but is not used by UDP. The link between the `socket` and `inpcb` is two way because sometimes the kernel starts at the socket layer and needs to find the corresponding Internet PCB (e.g., user output), and sometimes the kernel starts at the PCB and needs to locate the corresponding `socket` structure (e.g., processing a received IP datagram).

and  
pcb.h

52 If IP has a route to the foreign address, it is stored in the `inp_route` entry. We'll see that when an ICMP redirect message is received, all Internet PCBs are scanned and all those with a foreign IP address that matches the redirected IP address have their `inp_route` entry marked as invalid. This forces IP to find a new route to the foreign address the next time the PCB is used for output.

53 Various flags are stored in the `inp_flags` member. Figure 22.5 lists the individual flags.

inp_flags	Description
<code>INP_HDRINCL</code>	process supplies entire IP header (raw socket only)
<code>INP_RECVOPTS</code>	receive incoming IP options as control information (UDP only, not implemented)
<code>INP_RECVRETOPTS</code>	receive IP options for reply as control information (UDP only, not implemented)
<code>INP_RECVDSTADDR</code>	receive IP destination address as control information (UDP only)
<code>INP_CONTROLOPTS</code>	<code>INP_RECVOPTS   INP_RECVRETOPTS   INP_RECVDSTADDR</code>

Figure 22.5 `inp_flags` values.

pcb.h

54 A copy of an IP header is maintained in the PCB but only two members are used, the TOS and TTL. The TOS is initialized to 0 (normal service) and the TTL is initialized by the transport layer. We'll see that TCP and UDP both default the TTL to 64. A process can change these defaults using the `IP_TOS` or `IP_TTL` socket options, and the new value is recorded in the `inpcb.inp_ip` structure. This structure is then used by TCP and UDP as the prototype IP header when sending IP datagrams.

TCP.  
l list  
22.1);

55-56 A process can set the IP options for outgoing datagrams with the `IP_OPTIONS` socket option. A copy of the caller's options are stored in an mbuf by the function `ip_pcbopts` and a pointer to that mbuf is stored in the `inp_options` member. Each time TCP or UDP calls the `ip_output` function, a pointer to these IP options is passed for IP to insert into the outgoing IP datagram. Similarly, a pointer to a copy of the user's IP multicast options is maintained in the `inp_moptions` member.

ort,  
and  
CB in

store  
; here.  
ld dif-  
where  
everal  
finden  
ontrol  
oable,

## 22.4 `in_pcballoc` and `in_pcbdetach` Functions

An Internet PCB is allocated by TCP, UDP, and raw IP when a socket is created. A `PRU_ATTACH` request is issued by the `socket` system call. In the case of UDP, we'll see in Figure 23.33 that the resulting call is

```

struct socket *so;
int error;

error = in_pcballoc(so, &udb);

```

Figure 22.6 shows the `in_pcballoc` function.

```

36 int
37 in_pcballoc(so, head)
38 struct socket *so;
39 struct inpcb *head;
40 {
41     struct inpcb *inp;
42     MALLOC(inp, struct inpcb *, sizeof(*inp), M_PCB, M_WAITOK);
43     if (inp == NULL)
44         return (ENOBUFS);
45     bzero((caddr_t) inp, sizeof(*inp));
46     inp->inp_head = head;
47     inp->inp_socket = so;
48     insque(inp, head);
49     so->so_pcb = (caddr_t) inp;
50     return (0);
51 }

```

Figure 22.6 `in_pcballoc` function: allocate an Internet PCB.

#### Allocate PCB and initialize to zero

36-45 `in_pcballoc` calls the kernel's memory allocator using the macro `MALLOC`. Since these PCBs are always allocated as the result of a system call, it is OK to wait for one.

Net/2 and earlier Berkeley releases stored both Internet PCBs and TCP PCBs in mbufs. Their sizes were 80 and 108 bytes, respectively. With the Net/3 release, the sizes went to 84 and 140 bytes, so TCP control blocks no longer fit into an mbuf. Net/3 uses the kernel's memory allocator instead of mbufs for both types of control blocks.

Careful readers may note that the example in Figure 2.6 shows 17 mbufs allocated for PCBs, yet we just said that Net/3 no longer uses mbufs for Internet PCBs or TCP PCBs. Net/3 does, however, use mbufs for Unix domain PCBs, and that is what this counter refers to. The mbuf statistics output by `netstat` are for all mbufs in the kernel across all protocol suites, not just the Internet protocols.

`bzero` sets the PCB to 0. This is important because the IP addresses and port numbers in the PCB must be initialized to 0.

#### Link structures together

46-49 The `inp_head` member points to the head of the protocol's PCB list (either `udb` or `tcb`), the `inp_socket` member points to the socket structure, the new PCB is added to the protocol's doubly linked list (`insque`), and the socket structure points to the PCB. The `insque` function puts the new PCB at the head of the protocol's list.

An Internet PCB is deallocated when a PRU\_DETACH request is issued. This happens when the socket is closed. The function `in_pcbdetach`, shown in Figure 22.7, is eventually called.

```

252 int
253 in_pcbdetach(inp)
254 struct inpcb *inp;
255 {
256     struct socket *so = inp->inp_socket;

257     so->so_pcb = 0;
258     sofree(so);
259     if (inp->inp_options)
260         (void) m_free(inp->inp_options);
261     if (inp->inp_route.ro_rt)
262         rtfree(inp->inp_route.ro_rt);
263     ip_freemoptions(inp->inp_moptions);
264     remque(inp);
265     FREE(inp, M_PCB);
266 }

```

Figure 22.7 `in_pcbdetach` function: deallocate an Internet PCB.

252-263 The PCB pointer in the socket structure is set to 0 and that structure is released by `sofree`. If an mbuf with IP options was allocated for this PCB, it is released by `m_free`. If a route is held by this PCB, it is released by `rtfree`. Any multicast options are also released by `ip_freemoptions`.

264-265 The PCB is removed from the protocol's doubly linked list by `remque` and the memory used by the PCB is returned to the kernel.

## 22.5 Binding, Connecting, and Demultiplexing

Before examining the kernel functions that bind sockets, connect sockets, and demultiplex incoming datagrams, we describe the rules imposed by the kernel on these actions.

### Binding of Local IP Address and Port Number

Figure 22.8 shows the six different combinations of a local IP address and local port number that a process can specify in a call to `bind`.

The first three lines are typical for servers—they bind a specific port, termed the server's *well-known port*, whose value is known by the client. The last three lines are typical for clients—they don't care what the local port, termed an *ephemeral port*, is, as long as it is unique on the client host.

Most servers and most clients specify the wildcard IP address in the call to `bind`. This is indicated in Figure 22.8 by the notation `*` on lines 3 and 6.

Local IP address	Local port	Description
unicast or broadcast	nonzero	one local interface, specific port
multicast	nonzero	one local multicast group, specific port
*	nonzero	any local interface or multicast group, specific port
unicast or broadcast	0	one local interface, kernel chooses port
multicast	0	one multicast group, kernel chooses port
*	0	any local interface, kernel chooses port

Figure 22.8 Combination of local IP address and local port number for bind.

If a server binds a specific IP address to a socket (i.e., not the wildcard address), then only IP datagrams arriving with that specific IP address as the destination IP address—be it unicast, broadcast, or multicast—are delivered to the process. Naturally, when the process binds a specific unicast or broadcast IP address to a socket, the kernel verifies that the IP address corresponds to a local interface.

It is rare, though possible, for a client to bind a specific IP address (lines 4 and 5 in Figure 22.8). Normally a client binds the wildcard IP address (the final line in Figure 22.8), which lets the kernel choose the outgoing interface based on the route chosen to reach the server.

What we don't show in Figure 22.8 is what happens if the client tries to bind a local port that is already in use with another socket. By default a process cannot bind a port number if that port is already in use. The error `EADDRINUSE` (address already in use) is returned if this occurs. The definition of *in use* is simply whether a PCB exists with that port as its local port. This notion of "in use" is relative to a given protocol: TCP or UDP, since TCP port numbers are independent of UDP port numbers.

Net/3 allows a process to change this default behavior by specifying one of following two socket options:

`SO_REUSEADDR` Allows the process to bind a port number that is already in use, but the IP address being bound (including the wildcard) must not already be bound to that same port.

For example, if an attached interface has the IP address 140.252.1.29 then one socket can be bound to 140.252.1.29, port 5555; another socket can be bound to 127.0.0.1, port 5555; and another socket can be bound to the wildcard IP address, port 5555. The call to `bind` for the second and third cases must be preceded by a call to `setsockopt`, setting the `SO_REUSEADDR` option.

`SO_REUSEPORT` Allows a process to reuse both the IP address and port number, but *each* binding of the IP address and port number, including the first, must specify this socket option. With `SO_REUSEADDR`, the first binding of the port number need not specify the socket option.

For example, if an attached interface has the IP address 140.252.1.29 and a socket is bound to 140.252.1.29, port 6666 specifying the

Co

De

`SO_REUSEPORT` socket option, then another socket can also specify this same socket option and bind 140.252.1.29, port 6666.

Later in this section we describe what happens in this final example when an IP datagram arrives with a destination address of 140.252.1.29 and a destination port of 6666, since two sockets are bound to that end point.

The `SO_REUSEPORT` option is new with Net/3 and was introduced with the support for multicasting in 4.4BSD. Before this release it was never possible for two sockets to be bound to the same IP address and same port number.

Unfortunately the `SO_REUSEPORT` option was not part of the original Stanford multicast sources and is therefore not widely supported. Other systems that support multicasting, such as Solaris 2.x, let a process specify `SO_REUSEADDR` to specify that it is OK to bind multiple sockets to the same IP address and same port number.

### Connecting a UDP Socket

We normally associate the `connect` system call with TCP clients, but it is also possible for a UDP client or a UDP server to call `connect` and specify the foreign IP address and foreign port number for the socket. This restricts the socket to exchanging UDP datagrams with that one particular peer.

There is a side effect when a UDP socket is connected: the local IP address, if not already specified by a call to `bind`, is automatically set by `connect`. It is set to the local interface address chosen by IP routing to reach the specified peer.

Figure 22.9 shows the three different states of a UDP socket along with the pseudocode of the function calls to end up in that state.

Local socket	Foreign socket	Description
<i>localIP.lport</i>	<i>foreignIP.fport</i>	restricted to one peer: <code>socket(), bind(*, lport), connect(foreignIP, fport)</code> <code>socket(), bind(localIP, lport), connect(foreignIP, fport)</code>
<i>localIP.lport</i>	*.*	restricted to datagrams arriving on one local interface: <i>localIP</i> <code>socket(), bind(localIP, lport)</code>
*.lport	*.*	receives all datagrams sent to <i>lport</i> : <code>socket(), bind(*, lport)</code>

Figure 22.9 Specification of local and foreign IP addresses and port numbers for UDP sockets.

The first of the three states is called a *connected UDP socket* and the next two states are called *unconnected UDP sockets*. The difference between the two unconnected sockets is that the first has a fully specified local address and the second has a wildcarded local IP address.

### Demultiplexing of Received IP Datagrams by TCP

Figure 22.10 shows the state of three Telnet server sockets on the host sun. The first two sockets are in the LISTEN state, waiting for incoming connection requests, and the third

is connected to a client at port 1500 on the host with an IP address of 140.252.1.11. The first listening socket will handle connection requests that arrive on the 140.252.1.29 interface and the second listening socket will handle all other interfaces (since its local IP address is the wildcard).

Local address	Local port	Foreign address	Foreign port	TCP state
140.252.1.29	23	*	*	LISTEN
*	23	*	*	LISTEN
140.252.1.29	23	140.252.1.11	1500	ESTABLISHED

Figure 22.10 Three TCP sockets with a local port of 23.

We show both of the listening sockets with unspecified foreign IP addresses and port numbers because the sockets API doesn't allow a TCP server to restrict either of these values. A TCP server must accept the client's connection and is then told of the client's IP address and port number after the connection establishment is complete (i.e., when TCP's three-way handshake is complete). Only then can the server close the connection if it doesn't like the client's IP address and port number. This isn't a required TCP feature, it is just the way the sockets API has always worked.

When TCP receives a segment with a destination port of 23 it searches through its list of Internet PCBs looking for a match by calling `in_pcblookup`. When we examine this function shortly we'll see that it has a preference for the smallest number of *wildcard matches*. To determine the number of wildcard matches we consider only the local and foreign IP addresses. We do not consider the foreign port number. The local port number must match, or we don't even consider the PCB. The number of wildcard matches can be 0, 1 (local IP address or foreign IP address), or 2 (both local and foreign IP addresses).

For example, assume the incoming segment is from 140.252.1.11, port 1500, destined for 140.252.1.29, port 23. Figure 22.11 shows the number of wildcard matches for the three sockets from Figure 22.10.

Local address	Local port	Foreign address	Foreign port	TCP state	#wildcard matches
140.252.1.29	23	*	*	LISTEN	1
*	23	*	*	LISTEN	2
140.252.1.29	23	140.252.1.11	1500	ESTABLISHED	0

Figure 22.11 Incoming segment from {140.252.1.11, 1500} to {140.252.1.29, 23}.

The first socket matches these four values, but with one wildcard match (the foreign IP address). The second socket also matches the incoming segment, but with two wildcard matches (the local and foreign IP addresses). The third socket is a complete match with no wildcards. Net/3 uses the third socket, the one with the smallest number of wildcard matches.

Continuing this example, assume the incoming segment is from 140.252.1.11, port 1501, destined for 140.252.1.29, port 23. Figure 22.12 shows the number of wildcard matches.

Local address	Local port	Foreign address	Foreign port	TCP state	#wildcard matches
140.252.1.29	23	*	*	LISTEN	1
*	23	*	*	LISTEN	2
140.252.1.29	23	140.252.1.11	1500	ESTABLISHED	

Figure 22.12 Incoming segment from {140.252.1.11, 1501} to {140.252.1.29, 23}.

The first socket matches with one wildcard match; the second socket matches with two wildcard matches; and the third socket doesn't match at all, since the foreign port numbers are unequal. (The foreign port numbers are compared only if the foreign IP address in the PCB is not a wildcard.) The first socket is chosen.

In these two examples we never said what type of TCP segment arrived: we assume that the segment in Figure 22.11 contains data or an acknowledgment for an established connection since it is delivered to an established socket. We also assume that the segment in Figure 22.12 is an incoming connection request (a SYN) since it is delivered to a listening socket. But the demultiplexing code in `in_pcblookup` doesn't care. If the TCP segment is the wrong type for the socket that it is delivered to, we'll see later how TCP handles this. For now the important fact is that the demultiplexing code only compares the source and destination socket pair from the IP datagram against the values in the PCB.

### Demultiplexing of Received IP Datagrams by UDP

The delivery of UDP datagrams is more complicated than the TCP example we just examined, since UDP datagrams can be sent to a broadcast or multicast address. Since Net/3 (and most systems with multicast support) allow multiple sockets to have identical local IP addresses and ports, how are multiple recipients handled? The Net/3 rules are:

1. An incoming UDP datagram destined for either a broadcast IP address or a multicast IP address is delivered to *all* matching sockets. There is no concept of a "best" match here (i.e., the one with the smallest number of wildcard matches).
2. An incoming UDP datagram destined for a unicast IP address is delivered only to *one* matching socket, the one with the smallest number of wildcard matches. If there are multiple sockets with the same "smallest" number of wildcard matches, which socket receives the incoming datagram is implementation-dependent.

Figure 22.13 shows four UDP sockets that we'll use for some examples. Having four UDP sockets with the same local port number requires using either `SO_REUSEADDR` or `SO_REUSEPORT`. The first two sockets have been connected to a foreign IP address and port number, and the last two are unconnected.

Local address	Local port	Foreign address	Foreign port	Comment
140.252.1.29	577	140.252.1.11	1500	connected, local IP = unicast
140.252.13.63	577	140.252.13.35	1500	connected, local IP = broadcast
140.252.13.63	577	*	*	unconnected, local IP = broadcast
*	577	*	*	unconnected, local IP = wildcard

Figure 22.13 Four UDP sockets with a local port of 577.

Consider an incoming UDP datagram destined for 140.252.13.63 (the broadcast address on the 140.252.13 subnet), port 577, from 140.252.13.34, port 1500. Figure 22.14 shows that it is delivered to the third and fourth sockets.

Local address	Local port	Foreign address	Foreign port	Delivered?
140.252.1.29	577	140.252.1.11	1500	no, local and foreign IP mismatch
140.252.13.63	577	140.252.13.35	1500	no, foreign IP mismatch
140.252.13.63	577	*	*	yes
*	577	*	*	yes

Figure 22.14 Received datagram from {140.252.13.34, 1500} to {140.252.13.63, 577}.

The broadcast datagram is not delivered to the first socket because the local IP address doesn't match the destination IP address and the foreign IP address doesn't match the source IP address. It isn't delivered to the second socket because the foreign IP address doesn't match the source IP address.

As the next example, consider an incoming UDP datagram destined for 140.252.1.29 (a unicast address), port 577, from 140.252.1.11, port 1500. Figure 22.15 shows to which sockets the datagram is delivered.

Local address	Local port	Foreign address	Foreign port	Delivered?
140.252.1.29	577	140.252.1.11	1500	yes, 0 wildcard matches
140.252.13.63	577	140.252.13.35	1500	no, local and foreign IP mismatch
140.252.13.63	577	*	*	no, local IP mismatch
*	577	*	*	no, 2 wildcard matches

Figure 22.15 Received datagram from {140.252.1.11, 1500} to {140.252.1.29, 577}.

The datagram matches the first socket with no wildcard matches and also matches the fourth socket with two wildcard matches. It is delivered to the first socket, the best match.

## 22.6 in\_pcblookup Function

The function `in_pcblookup` serves four different purposes.

1. When either TCP or UDP receives an IP datagram, `in_pcblookup` scans the protocol's list of Internet PCBs looking for a matching PCB to receive the



datagram. This is transport layer demultiplexing of a received datagram.

2. When a process executes the `bind` system call, to assign a local IP address and local port number to a socket, `in_pcbbind` is called by the protocol to verify that the requested local address pair is not already in use.
3. When a process executes the `bind` system call, requesting an ephemeral port be assigned to its socket, the kernel picks an ephemeral port and calls `in_pcbbind` to check if the port is in use. If it is in use, the next ephemeral port number is tried, and so on, until an unused port is located.
4. When a process executes the `connect` system call, either explicitly or implicitly, `in_pcbbind` verifies that the requested socket pair is unique. (An implicit call to connect happens when a UDP datagram is sent on an unconnected socket. We'll see this scenario in Chapter 23.)

In cases 2, 3, and 4 `in_pcbbind` calls `in_pcblookup`. Two options confuse the logic of the function. First, a process can specify either the `SO_REUSEADDR` or `SO_REUSEPORT` socket option to say that a duplicate local address is OK.

Second, sometimes a wildcard match is OK (e.g., an incoming UDP datagram can match a PCB that has a wildcard for its local IP address, meaning that the socket will accept UDP datagrams that arrive on any local interface), while other times a wildcard match is forbidden (e.g., when connecting to a foreign IP address and port number).

In the original Stanford IP multicast code appears the comment that "The logic of `in_pcblookup` is rather opaque and there is not a single comment, . . ." The adjective *opaque* is an understatement.

The publicly available IP multicast code available for BSD/386, which is derived from the port to 4.4BSD done by Craig Leres, fixed the overloaded semantics of this function by using `in_pcblookup` only for case 1 above. Cases 2 and 4 are handled by a new function named `in_pcbconflict`, and case 3 is handled by a new function named `in_uniqueport`. Dividing the original functionality into separate functions is much clearer, but in the Net/3 release, which we're describing in this text, the logic is still combined into the single function `in_pcblookup`.

Figure 22.16 shows the `in_pcblookup` function.

The function starts at the head of the protocol's PCB list and potentially goes through every PCB on the list. The variable `match` remembers the pointer to the entry with the best match so far, and `matchwild` remembers the number of wildcards in that match. The latter is initialized to 3, which is a value greater than the maximum number of wildcard matches that can be encountered. (Any value greater than 2 would work.) Each time around the loop, the variable `wildcard` starts at 0 and counts the number of wildcard matches for each PCB.

#### Compare local port number

416-417 The first comparison is the local port number. If the PCB's local port doesn't match the `lport` argument, the PCB is ignored.

```

405 struct inpcb *
406 in_pcblookup(head, faddr, fport_arg, laddr, lport_arg, flags)
407 struct inpcb *head;
408 struct in_addr faddr, laddr;
409 u_int fport_arg, lport_arg;
410 int flags;
411 {
412     struct inpcb *inp, *match = 0;
413     int matchwild = 3, wildcard;
414     u_short fport = fport_arg, lport = lport_arg;

415     for (inp = head->inp_next; inp != head; inp = inp->inp_next) {
416         if (inp->inp_lport != lport)
417             continue; /* ignore if local ports are unequal */

418         wildcard = 0;

419         if (inp->inp_laddr.s_addr != INADDR_ANY) {
420             if (laddr.s_addr == INADDR_ANY)
421                 wildcard++;
422             else if (inp->inp_laddr.s_addr != laddr.s_addr)
423                 continue;
424         } else {
425             if (laddr.s_addr != INADDR_ANY)
426                 wildcard++;
427         }

428         if (inp->inp_faddr.s_addr != INADDR_ANY) {
429             if (faddr.s_addr == INADDR_ANY)
430                 wildcard++;
431             else if (inp->inp_faddr.s_addr != faddr.s_addr ||
432                    inp->inp_fport != fport)
433                 continue;
434         } else {
435             if (faddr.s_addr != INADDR_ANY)
436                 wildcard++;
437         }

438         if (wildcard && (flags & INPLOOKUP_WILDCARD) == 0)
439             continue; /* wildcard match not allowed */

440         if (wildcard < matchwild) {
441             match = inp;
442             matchwild = wildcard;
443             if (matchwild == 0)
444                 break; /* exact match, all done */
445         }
446     }
447     return (match);
448 }

```

Figure 22.16 in\_pcblookup function: search all the PCBs for a match.

### Compare local address

419-427 `in_pcblookup` compares the local address in the PCB with the `laddr` argument. If one is a wildcard and the other is not a wildcard, the `wildcard` counter is incremented. If both are not wildcards, then they must be the same, or this PCB is ignored. If both are wildcards, nothing changes: they can't be compared and the `wildcard` counter isn't incremented. Figure 22.17 summarizes the four different conditions.

PCB local IP	<code>laddr</code> argument	Description
not *	*	wildcard++
not *	not *	compare IP addresses, skip PCB if not equal
*	*	can't compare
*	not *	wildcard++

Figure 22.17 Four scenarios for the local IP address comparison done by `in_pcblookup`.

### Compare foreign address and foreign port number

428-437 These lines perform the same test that we just described, but using the foreign addresses instead of the local addresses. Also, if both foreign addresses are not wildcards then not only must the two IP addresses be equal, but the two foreign ports must also be equal. Figure 22.18 summarizes the foreign IP comparisons.

PCB foreign IP	<code>faddr</code> argument	Description
not *	*	wildcard++
not *	not *	compare IP addresses and ports, skip PCB if not equal
*	*	can't compare
*	not *	wildcard++

Figure 22.18 Four scenarios for the foreign IP address comparison done by `in_pcblookup`.

The additional comparison of the foreign port numbers can be performed for the second line of Figure 22.18 because it is not possible to have a PCB with a nonwildcard foreign address and a foreign port number of 0. This restriction is enforced by `connect`, which we'll see shortly requires a nonwildcard foreign IP address and a nonzero foreign port. It is possible, however, and common, to have a wildcard local address with a nonzero local port. We saw this in Figures 22.10 and 22.13.

### Check if wildcard match allowed

438-439 The `flags` argument can be set to `INPLOOKUP_WILDCARD`, which means a match containing wildcards is OK. If a match is found containing wildcards (`wildcard` is nonzero) and this flag was not specified by the caller, this PCB is ignored. When TCP and UDP call this function to demultiplex an incoming datagram, `INPLOOKUP_WILDCARD` is always set, since a wildcard match is OK. (Recall our examples using Figures 22.10 and 22.13.) But when this function is called as part of the `connect` system call, in order to verify that a socket pair is not already in use, the `flags` argument is set to 0.

**Remember best match, return if exact match found**

440-447 These statements remember the best match found so far. Again, the best match is considered the one with the fewest number of wildcard matches. If a match is found with one or two wildcards, that match is remembered and the loop continues. But if an exact match is found (`wildcard` is 0), the loop terminates, and a pointer to the PCB with that exact match is returned.

**Example—Demultiplexing of Received TCP Segment**

Figure 22.19 is from the TCP example we discussed with Figure 22.11. Assume `in_pcblookup` is demultiplexing a received datagram from 140.252.1.11, port 1500, destined for 140.252.1.29, port 23. Also assume that the order of the PCBs is the order of the rows in the figure. `laddr` is the destination IP address, `lport` is the destination TCP port, `faddr` is the source IP address, and `fport` is the source TCP port.

PCB values				wildcard
Local address	Local port	Foreign address	Foreign port	
140.252.1.29	23	*	*	1
*	23	*	*	2
140.252.1.29	23	140.252.1.11	1500	0

Figure 22.19 `laddr = 140.252.1.29`, `lport = 23`, `faddr = 140.252.1.11`, `fport = 1500`.

When the first row is compared to the incoming segment, `wildcard` is 1 (the foreign IP address), `flags` is set to `INPLOOKUP_WILDCARD`, so `match` is set to point to this PCB and `matchwild` is set to 1. The loop continues since an exact match has not been found yet. The next time around the loop, `wildcard` is 2 (the local and foreign IP addresses) and since this is greater than `matchwild`, the entry is not remembered, and the loop continues. The next time around the loop, `wildcard` is 0, which is less than `matchwild` (1), so this entry is remembered in `match`. The loop also terminates since an exact match has been found and the pointer to this PCB is returned to the caller.

If `in_pcblookup` were used by TCP and UDP only to demultiplex incoming datagrams, it could be simplified. First, there's no need to check whether the `faddr` or `laddr` arguments are wildcards, since these are the source and destination IP addresses from the received datagram. Also the `flags` argument could be removed, along with its corresponding test, since wildcard matches are always OK.

This section has covered the mechanics of the `in_pcblookup` function. We'll return to this function and discuss its meaning after seeing how it is called from the `in_pcbbind` and `in_pcbconnect` functions.

**22.7 in\_pcbbind Function**

The next function, `in_pcbbind`, binds a local address and port number to a socket. It is called from five functions:

1. from `bind` for a TCP socket (normally to bind a server's well-known port);
2. from `bind` for a UDP socket (either to bind a server's well-known port or to bind an ephemeral port to a client's socket);
3. from `connect` for a TCP socket, if the socket has not yet been bound to a nonzero port (this is typical for TCP clients);
4. from `listen` for a TCP socket, if the socket has not yet been bound to a nonzero port (this is rare, since `listen` is called by a TCP server, which normally binds a well-known port, not an ephemeral port); and
5. from `in_pcbconnect` (Section 22.8), if the local IP address and local port number have not been set (typical for a call to `connect` for a UDP socket or for each call to `sendto` for an unconnected UDP socket).

In cases 3, 4, and 5, an ephemeral port number is bound to the socket and the local IP address is not changed (in case it is already set).

We call cases 1 and 2 *explicit binds* and cases 3, 4, and 5 *implicit binds*. We also note that although it is normal in case 2 for a server to bind a well-known port, servers invoked using remote procedure calls (RPC) often bind ephemeral ports and then register their ephemeral port with another program that maintains a mapping between the server's RPC program number and its ephemeral port (e.g., the Sun port mapper described in Section 29.4 of Volume 1).

We'll show the `in_pcbbind` function in three sections. Figure 22.20 is the first section.

```

52 int
53 in_pcbbind(inp, nam)
54 struct inpcb *inp;
55 struct mbuf *nam;
56 {
57     struct socket *so = inp->inp_socket;
58     struct inpcb *head = inp->inp_head;
59     struct sockaddr_in *sin;
60     struct proc *p = curproc; /* XXX */
61     u_short lport = 0;
62     int wild = 0, reuseport = (so->so_options & SO_REUSEPORT);
63     int error;

64     if (in_ifaddr == 0)
65         return (EADDRNOTAVAIL);
66     if (inp->inp_lport || inp->inp_laddr.s_addr != INADDR_ANY)
67         return (EINVAL);

68     if ((so->so_options & (SO_REUSEADDR | SO_REUSEPORT)) == 0 &&
69         ((so->so_proto->pr_flags & PR_CONNREQUIRED) == 0 ||
70         (so->so_options & SO_ACCEPTCONN) == 0))
71         wild = INPLOOKUP_WILDCARD;

```

*in\_pcb.c*

Figure 22.20 `in_pcbbind` function: bind a local address and port number.

64-67 The first two tests verify that at least one interface has been assigned an IP address and that the socket is not already bound. You can't bind a socket twice.

68-71 This `if` statement is confusing. The `net` result sets the variable `wild` to `INPLOOKUP_WILDCARD` if neither `SO_REUSEADDR` or `SO_REUSEPORT` are set.

The second test is true for UDP sockets since `PR_CONNREQUIRED` is false for connectionless sockets and true for connection-oriented sockets.

The third test is where the confusion lies [Torek 1992]. The socket flag `SO_ACCEPTCONN` is set only by the `listen` system call (Section 15.9), which is valid only for a connection-oriented server. In the normal scenario, a TCP server calls `socket`, `bind`, and then `listen`. Therefore, when `in_pcbbind` is called by `bind`, this socket flag is cleared. Even if the process calls `socket` and then `listen`, without calling `bind`, TCP's `PRU_LISTEN` request calls `in_pcbbind` to assign an ephemeral port to the socket *before* the socket layer sets the `SO_ACCEPTCONN` flag. This means the third test in the `if` statement, testing whether `SO_ACCEPTCONN` is not set, is always true. The `if` statement is therefore equivalent to

```
if ((so->so_options & (SO_REUSEADDR|SO_REUSEPORT)) == 0 &&
    ((so->so_proto->pr_flags & PR_CONNREQUIRED) == 0 || 1)
    wild = INPLOOKUP_WILDCARD;
```

Since anything logically ORed with 1 is always true, this is equivalent to

```
if ((so->so_options & (SO_REUSEADDR|SO_REUSEPORT)) == 0)
    wild = INPLOOKUP_WILDCARD;
```

which is simpler to understand: if either of the REUSE socket options is set, `wild` is left as 0. If neither of the REUSE socket options are set, `wild` is set to `INPLOOKUP_WILDCARD`. In other words, when `in_pcblookup` is called later in the function, a wildcard match is allowed only if *neither* of the REUSE socket options are on.

The next section of the `in_pcbbind`, shown in Figure 22.22, function processes the optional `nam` argument.

72-75 The `nam` argument is a nonnull pointer only when the process calls `bind` explicitly. For an implicit bind (a side effect of `connect`, `listen`, or `in_pcbconnect`, cases 3, 4, and 5 from the beginning of this section), `nam` is a null pointer. When the argument is specified, it is an mbuf containing a `sockaddr_in` structure. Figure 22.21 shows the four cases for the nonnull `nam` argument.

nam argument:		PCB member gets set to:		Comment
<i>localIP</i>	<i>lport</i>	<i>inp_laddr</i>	<i>inp_lport</i>	
not *	0	<i>localIP</i>	ephemeral port	<i>localIP</i> must be local interface subject to <code>in_pcblookup</code>
not *	nonzero	<i>localIP</i>	<i>lport</i>	
*	0	*	ephemeral port	subject to <code>in_pcblookup</code>
*	nonzero	*	<i>lport</i>	

Figure 22.21 Four cases for `nam` argument to `in_pcbbind`.

76-83 The test for the correct address family is commented out, yet the identical test in the `in_pcbconnect` function (Figure 22.25) is performed. We expect either both to be in or both to be out.

```

72     if (nam) {
73         sin = mtod(nam, struct sockaddr_in *);
74         if (nam->m_len != sizeof(*sin))
75             return (EINVAL);
76 #ifdef notdef
77     /*
78      * We should check the family, but old programs
79      * incorrectly fail to initialize it.
80      */
81     if (sin->sin_family != AF_INET)
82         return (EAFNOSUPPORT);
83 #endif
84     lport = sin->sin_port; /* might be 0 */
85     if (IN_MULTICAST(ntohl(sin->sin_addr.s_addr)) {
86         /*
87          * Treat SO_REUSEADDR as SO_REUSEPORT for multicast;
88          * allow complete duplication of binding if
89          * SO_REUSEPORT is set, or if SO_REUSEADDR is set
90          * and a multicast address is bound on both
91          * new and duplicated sockets.
92          */
93         if (so->so_options & SO_REUSEADDR)
94             reuseport = SO_REUSEADDR | SO_REUSEPORT;
95     } else if (sin->sin_addr.s_addr != INADDR_ANY) {
96         sin->sin_port = 0; /* yech... */
97         if (ifa_ifwithaddr((struct sockaddr *) sin) == 0)
98             return (EADDRNOTAVAIL);
99     }
100     if (lport) {
101         struct inpcb *t;
102         /* GROSS */
103         if (ntohs(lport) < IPPORT_RESERVED &&
104             (error = suser(p->p_ucred, &p->p_acflag)))
105             return (error);
106         t = in_pcblookup(head, zero_in_addr, 0,
107             sin->sin_addr, lport, wild);
108         if (t && (reuseport & t->inp_socket->so_options) == 0)
109             return (EADDRINUSE);
110     }
111     inp->inp_laddr = sin->sin_addr; /* might be wildcard */
112 }

```

Figure 22.22 in\_pcbbind function: process optional nam argument.

85-94 Net/3 tests whether the IP address being bound is a multicast group. If so, the SO\_REUSEADDR option is considered identical to SO\_REUSEPORT.

95-99 Otherwise, if the local address being bound by the caller is not the wildcard, ifa\_ifwithaddr verifies that the address corresponds to a local interface.

The comment "yech" is probably because the port number in the socket address structure must be 0 because ifa\_ifwithaddr does a binary comparison of the entire structure, not just a comparison of the IP addresses.

This is one of the few instances where the process *must* zero the socket address structure before issuing the system call. If `bind` is called and the final 8 bytes of the socket address structure (`sin_zero[8]`) are nonzero, `ifa_ifwithaddr` will not find the requested interface, and `in_pcbbind` will return an error.

100-105 The next `if` statement is executed when the caller is binding a nonzero port, that is, the process wants to bind one particular port number (the second and fourth scenarios from Figure 22.21). If the requested port is less than 1024 (`IPPORT_RESERVED`) the process must have superuser privilege. This is not part of the Internet protocols, but a Berkeley convention. A port number less than 1024 is called a *reserved port* and is used, for example, by the `rcmd` function [Stevens 1990], which in turn is used by the `rlogin` and `rsh` client programs as part of their authentication with their servers.

106-109 The function `in_pcblookup` (Figure 22.16) is then called to check whether a PCB already exists with the same local IP address and local port number. The second argument is the wildcard IP address (the foreign IP address) and the third argument is a port number of 0 (the foreign port). The wildcard value for the second argument causes `in_pcblookup` to ignore the foreign IP address and foreign port in the PCB—only the local IP address and local port are compared to `sin->sin_addr` and `lport`, respectively. We mentioned earlier that `wild` is set to `INPLOOKUP_WILDCARD` only if neither of the `REUSE` socket options are set.

111 The caller's value for the local IP address is stored in the PCB. This can be the wildcard address, if that's the value specified by the caller. In this case the local IP address is chosen by the kernel, but not until the socket is connected at some later time. This is because the local IP address is determined by IP routing, based on foreign IP address.

The final section of `in_pcbbind` handles the assignment of an ephemeral port when the caller explicitly binds a port of 0, or when the `nam` argument is a null pointer (an implicit bind).

```

113     if (lport == 0)
114         do {
115             if (head->inp_lport++ < IPPORT_RESERVED ||
116                 head->inp_lport > IPPORT_USERRESERVED)
117                 head->inp_lport = IPPORT_RESERVED;
118             lport = htons(head->inp_lport);
119         } while (in_pcblookup(head,
120                             zero_in_addr, 0, inp->inp_laddr, lport, wild));
121     inp->inp_lport = lport;
122     return (0);
123 }

```

in\_pcb.c

Figure 22.23 `in_pcbbind` function: choose an ephemeral port.

113-122 The next ephemeral port number to use for this protocol (TCP or UDP) is maintained in the head of the protocol's PCB list: `tcb` or `udb`. Other than the `inp_next` and `inp_back` pointers in the protocol's head PCB, the only other element of the `inpcb` structure that is used is the local port number. Confusingly, this local port number is maintained in host byte order in the head PCB, but in network byte order in all the other PCBs on the list! The ephemeral port numbers start at 1024



(IPPORT\_RESERVED) and get incremented by 1 until port 5000 is used (IPPORT\_USERRESERVED), then cycle back to 1024. The loop is executed until `in_pcbbind` does not find a match.

### SO\_REUSEADDR Examples

Let's look at some common examples to see the interaction of `in_pcbbind` with `in_pcblookup` and the two REUSE socket options.

1. A TCP or UDP server normally starts by calling `socket` and `bind`. Assume a TCP server that calls `bind`, specifying the wildcard IP address and its nonzero well-known port, say 23 (the Telnet server). Also assume that the server is not already running and that the process does not set the `SO_REUSEADDR` socket option.

`in_pcbbind` calls `in_pcblookup` with `INPLOOKUP_WILDCARD` as the final argument. The loop in `in_pcblookup` won't find a matching PCB, assuming no other process is using the server's well-known TCP port, causing a null pointer to be returned. This is OK and `in_pcbbind` returns 0.

2. Assume the same scenario as above, but with the server already running when someone tries to start the server a second time.

When `in_pcblookup` is called it finds the PCB with a local socket of `{*, 23}`. Since the wildcard counter is 0, `in_pcblookup` returns the pointer to this entry. Since `reuseport` is 0, `in_pcbbind` returns `EADDRINUSE`.

3. Assume the same scenario as the previous example, but when the attempt is made to start the server a second time, the `SO_REUSEADDR` socket option is specified.

Since this socket option is specified, `in_pcbbind` calls `in_pcblookup` with a final argument of 0. But the PCB with a local socket of `{*, 23}` is still matched and returned because wildcard is 0, since `in_pcblookup` cannot compare the two wildcard addresses (Figure 22.17). `in_pcbbind` again returns `EADDRINUSE`, preventing us from starting two instances of the server with identical local sockets, regardless of whether we specify `SO_REUSEADDR` or not.

4. Assume that a Telnet server is already running with a local socket of `{*, 23}` and we try to start another with a local socket of `{140.252.13.35, 23}`.

Assuming `SO_REUSEADDR` is not specified, `in_pcblookup` is called with a final argument of `INPLOOKUP_WILDCARD`. When it compares the PCB containing `*.23`, the counter wildcard is set to 1. Since a wildcard match is allowed, this match is remembered as the best match and a pointer to it is returned after all the TCP PCBs are scanned. `in_pcbbind` returns `EADDRINUSE`.

5. This example is the same as the previous one, but we specify the `SO_REUSEADDR` socket option for the second server that tries to bind the local socket `{140.252.13.35, 23}`.

The final argument to `in_pcblookup` is now 0, since the socket option is specified. When the PCB with the local socket `{*, 23}` is compared, the wildcard counter is 1,

but since the final `flags` argument is 0, this entry is skipped and is not remembered as a match. After comparing all the TCP PCBs, the function returns a null pointer and `in_pcbbind` returns 0.

6. Assume the first Telnet server is started with a local socket of {140.252.13.35, 23} when we try to start a second server with a local socket of {\*, 23}. This is the same as the previous example, except we're starting the servers in reverse order this time.

The first server is started without a problem, assuming no other socket has already bound port 23. When we start the second server, the final argument to `in_pcblookup` is `INPLOOKUP_WILDCARD`, assuming the `SO_REUSEADDR` socket option is not specified. When the PCB with the local socket of {140.252.13.35, 23} is compared, the `wildcard` counter is set to 1 and this entry is remembered. After all the TCP PCBs are compared, the pointer to this entry is returned, causing `in_pcbbind` to return `EADDRINUSE`.

7. What if we start two instances of a server, both with a nonwildcard local IP address? Assume we start the first Telnet server with a local socket of {140.252.13.35, 23} and then try to start a second with a local socket of {127.0.0.1, 23}, without specifying `SO_REUSEADDR`.

When the second server calls `in_pcbbind`, it calls `in_pcblookup` with a final argument of `INPLOOKUP_WILDCARD`. When the PCB with the local socket of {140.252.13.35, 23} is compared, it is skipped because the local IP addresses are not equal. `in_pcblookup` returns a null pointer, and `in_pcbbind` returns 0.

From this example we see that the `SO_REUSEADDR` socket option has no effect on nonwildcard IP addresses. Indeed the test on the `flags` value `INPLOOKUP_WILDCARD` in `in_pcblookup` is made only when `wildcard` is greater than 0, that is, when either the PCB entry has a wildcard IP address or the IP address being bound is the wildcard.

8. As a final example, assume we try to start two instances of the same server, both with the same nonwildcard local IP address, say 127.0.0.1.

When the second server is started, `in_pcblookup` always returns a pointer to the matching PCB with the same local socket. This happens regardless of the `SO_REUSEADDR` socket option, because the `wildcard` counter is always 0 for this comparison. Since `in_pcblookup` returns a nonnull pointer, `in_pcbbind` returns `EADDRINUSE`.

From these examples we can state the rules about the binding of local IP addresses and the `SO_REUSEADDR` socket option. These rules are shown in Figure 22.24. We assume that `localIP1` and `localIP2` are two different unicast or broadcast IP addresses valid on the local host, and that `localmcastIP` is a multicast group. We also assume that the process is trying to bind the same nonzero port number that is already bound to the existing PCB.

We need to differentiate between a unicast or broadcast address and a multicast address, because we saw that `in_pcbbind` considers `SO_REUSEADDR` to be the same as `SO_REUSEPORT` for a multicast address.

Existing PCB	Try to bind	SO_REUSEADDR		Description
		off	on	
<i>localIP1</i>	<i>localIP1</i>	error	error	one server per IP address and port
<i>localIP1</i>	<i>localIP2</i>	OK	OK	one server for each local interface
<i>localIP1</i>	*	error	OK	one server for one interface, other server for remaining interfaces
*	<i>localIP1</i>	error	OK	one server for one interface, other server for remaining interfaces
*	*	error	error	can't duplicate local sockets (same as first example)
<i>localmcastIP</i>	<i>localmcastIP</i>	error	OK	multiple multicast recipients

Figure 22.24 Effect of SO\_REUSEADDR socket option on binding of local IP address.

### SO\_REUSEPORT Socket Option

The handling of SO\_REUSEPORT in Net/3 changes the logic of `in_pcbbind` to allow duplicate local sockets as long as both sockets specify SO\_REUSEPORT. In other words, all the servers must agree to share the same local port.

## 22.8 in\_pcbconnect Function

The function `in_pcbconnect` specifies the foreign IP address and foreign port number for a socket. It is called from four functions:

1. from `connect` for a TCP socket (required for a TCP client);
2. from `connect` for a UDP socket (optional for a UDP client, rare for a UDP server);
3. from `sendto` when a datagram is output on an unconnected UDP socket (common); and
4. from `tcp_input` when a connection request (a SYN segment) arrives on a TCP socket that is in the LISTEN state (standard for a TCP server).

In all four cases it is common, though not required, for the local IP address and local port be unspecified when `in_pcbconnect` is called. Therefore one function of `in_pcbconnect` is to assign the local values when they are unspecified.

We'll discuss the `in_pcbconnect` function in four sections. Figure 22.25 shows the first section.

```

130 int
131 in_pcbconnect(inp, nam)
132 struct inpcb *inp;
133 struct mbuf *nam;
134 {
135     struct in_ifaddr *ia;
136     struct sockaddr_in *ifaddr;
137     struct sockaddr_in *sin = mtod(nam, struct sockaddr_in *);

```

*in\_pcb.c*

```

138     if (nam->m_len != sizeof(*sin))
139         return (EINVAL);
140     if (sin->sin_family != AF_INET)
141         return (EAFNOSUPPORT);
142     if (sin->sin_port == 0)
143         return (EADDRNOTAVAIL);
144     if (in_ifaddr) {
145         /*
146          * If the destination address is INADDR_ANY,
147          * use the primary local address.
148          * If the supplied address is INADDR_BROADCAST,
149          * and the primary interface supports broadcast,
150          * choose the broadcast address for that interface.
151          */
152     #define satosin(sa)      ((struct sockaddr_in *) (sa))
153     #define sintosa(sin)    ((struct sockaddr *) (sin))
154     #define ifatoia(ifa)   ((struct in_ifaddr *) (ifa))
155     if (sin->sin_addr.s_addr == INADDR_ANY)
156         sin->sin_addr = IA_SIN(in_ifaddr->sin_addr);
157     else if (sin->sin_addr.s_addr == (u_long) INADDR_BROADCAST &&
158             (in_ifaddr->ia_ifp->if_flags & IFF_BROADCAST))
159         sin->sin_addr = satosin(&in_ifaddr->ia_broadaddr)->sin_addr;
160     }

```

*in\_pcb.c*

Figure 22.25 `in_pcbconnect` function: verify arguments, check foreign IP address.

#### Validate argument

130-143 The `nam` argument points to an mbuf containing a `sockaddr_in` structure with the foreign IP address and port number. These lines validate the argument and verify that the caller is not trying to connect to a port number of 0.

#### Handle connection to 0.0.0.0 and 255.255.255.255 specially

144-160 The test of the global `in_ifaddr` verifies that an IP interface has been configured. If the foreign IP address is 0.0.0.0 (`INADDR_ANY`), then 0.0.0.0 is replaced with the IP address of the primary IP interface. This means the calling process is connecting to a peer on this host. If the foreign IP address is 255.255.255.255 (`INADDR_BROADCAST`) and the primary interface supports broadcasting, then 255.255.255.255 is replaced with the broadcast address of the primary interface. This allows a UDP application to broadcast on the primary interface without having to figure out its IP address—it can simply send datagrams to 255.255.255.255, and the kernel converts this to the appropriate IP address for the interface.

The next section of code, Figure 22.26, handles the case of an unspecified local address. This is the common scenario for TCP and UDP clients, cases 1, 2, and 3 from the list at the beginning of this section.

```

161     if (inp->inp_laddr.s_addr == INADDR_ANY) {
162         struct route *ro;

163         ia = (struct in_ifaddr *) 0;
164         /*
165          * If route is known or can be allocated now,
166          * our src addr is taken from the i/f, else punt.
167          */
168         ro = &inp->inp_route;
169         if (ro->ro_rt &&
170             (satosin(&ro->ro_dst)->sin_addr.s_addr !=
171              sin->sin_addr.s_addr ||
172              inp->inp_socket->so_options & SO_DONTROUTE)) {
173             RTFREE(ro->ro_rt);
174             ro->ro_rt = (struct rtable *) 0;
175         }
176         if ((inp->inp_socket->so_options & SO_DONTROUTE) == 0 &&
177             (ro->ro_rt == (struct rtable *) 0 ||
178              ro->ro_rt->rt_ifp == (struct ifnet *) 0)) {
179             /* No route yet, so try to acquire one */
180             ro->ro_dst.sa_family = AF_INET;
181             ro->ro_dst.sa_len = sizeof(struct sockaddr_in);
182             ((struct sockaddr_in *) &ro->ro_dst)->sin_addr =
183                 sin->sin_addr;
184             rtalloc(ro);
185         }
186         /*
187          * If we found a route, use the address
188          * corresponding to the outgoing interface
189          * unless it is the loopback (in case a route
190          * to our address on another net goes to loopback).
191          */
192         if (ro->ro_rt && !(ro->ro_rt->rt_ifp->if_flags & IFF_LOOPBACK))
193             ia = ifatoia(ro->ro_rt->rt_ifa);
194         if (ia == 0) {
195             u_short fport = sin->sin_port;
196             sin->sin_port = 0;
197             ia = ifatoia(ifa_ifwithdstaddr(sintosa(sin)));
198             if (ia == 0)
199                 ia = ifatoia(ifa_ifwithnet(sintosa(sin)));
200             sin->sin_port = fport;
201             if (ia == 0)
202                 ia = in_ifaddr;
203             if (ia == 0)
204                 return (EADDRNOTAVAIL);
205         }

```

Figure 22.26 in\_pcbconnect function: local IP address not yet specified.

**Release route if no longer valid**

164-175 If a route is held by the PCB but the destination of that route differs from the foreign address being connected to, or the `SO_DONTRROUTE` socket option is set, that route is released.

To understand why a PCB may have an associated route, consider case 3 from the list at the beginning of this section: `in_pcbconnect` is called *every time* a UDP datagram is sent on an unconnected socket. Each time a process calls `sendto`, the UDP output function calls `in_pcbconnect`, `ip_output`, and `in_pcbdisconnect`. If all the datagrams sent on the socket go to the same destination IP address, then the first time through `in_pcbconnect` the route is allocated and it can be used from that point on. But since a UDP application can send datagrams to a different IP address with each call to `sendto`, the destination address must be compared to the saved route and the route released when the destination changes. This same test is done in `ip_output`, which seems to be redundant.

The `SO_DONTRROUTE` socket option tells the kernel to bypass the normal routing decisions and send the IP datagram to the locally attached interface whose IP network address matches the network portion of the destination address.

**Acquire route**

176-185 If the `SO_DONTRROUTE` socket option is not set, and a route to the destination is not held by the PCB, try to acquire one by calling `rtalloc`.

**Determine outgoing interface**

186-205 The goal in this section of code is to have `ia` point to an interface address structure (`in_ifaddr`, Section 6.5), which contains the IP address of the interface. If the PCB holds a route that is still valid, or if `rtalloc` found a route, and the route is not to the loopback interface, the corresponding interface is used. Otherwise `ifa_withdstaddr` and `ifa_withnet` are called to check if the foreign IP address is on the other end of a point-to-point link or on an attached network. Both of these functions require that the port number in the socket address structure be 0, so it is saved in `fport` across the calls. If this fails, the primary IP address is used (`in_ifaddr`), and if no interfaces are configured (`in_ifaddr` is zero), an error is returned.

Figure 22.27 shows the next section of `in_pcbconnect`, which handles a destination address that is a multicast address.

206-223 If the destination address is a multicast address and the process has specified the outgoing interface to use for multicast packets (using the `IP_MULTICAST_IF` socket option), then the IP address of that interface is used as the local address. A search is made of all IP interfaces for the one matching the interface that was specified with the socket option. An error is returned if that interface is no longer up.

224-225 The code that started at the beginning of Figure 22.26 to handle the case of a wildcard local address is complete. The pointer to the `sockaddr_in` structure for the local interface `ia` is saved in `ifaddr`.

The final section of `in_pcblookup` is shown in Figure 22.28.

```

206      /*
207      * If the destination address is multicast and an outgoing
208      * interface has been set as a multicast option, use the
209      * address of that interface as our source address.
210      */
211      if (IN_MULTICAST(ntohl(sin->sin_addr.s_addr)) &&
212          inp->inp_moptions != NULL) {
213          struct ip_moptions *imo;
214          struct ifnet *ifp;
215
216          imo = inp->inp_moptions;
217          if (imo->imo_multicast_ifp != NULL) {
218              ifp = imo->imo_multicast_ifp;
219              for (ia = in_ifaddr; ia; ia = ia->ia_next)
220                  if (ia->ia_ifp == ifp)
221                      break;
222              if (ia == 0)
223                  return (EADDRNOTAVAIL);
224          }
225          ifaddr = (struct sockaddr_in *) &ia->ia_addr;
226      }

```

Figure 22.27 in\_pcbconnect function: destination address is a multicast address.

```

227      if (in_pcblookup(inp->inp_head,
228                     sin->sin_addr,
229                     sin->sin_port,
230                     inp->inp_laddr.s_addr ? inp->inp_laddr : ifaddr->sin_addr,
231                     inp->inp_lport,
232                     0))
233          return (EADDRINUSE);
234
235      if (inp->inp_laddr.s_addr == INADDR_ANY) {
236          if (inp->inp_lport == 0)
237              (void) in_pcbbind(inp, (struct mbuf *) 0);
238          inp->inp_laddr = ifaddr->sin_addr;
239      }
240      inp->inp_faddr = sin->sin_addr;
241      inp->inp_fport = sin->sin_port;
242      return (0);

```

Figure 22.28 in\_pcbconnect function: verify that socket pair is unique.

### Verify that socket pair is unique

227-233 in\_pcblookup verifies that the socket pair is unique. The foreign address and foreign port are the values specified as arguments to in\_pcbconnect. The local address is either the value that was already bound to the socket or the value in ifaddr that was

calculated in the code we just described. The local port can be 0, which is typical for a TCP client, and we'll see that later in this section of code an ephemeral port is chosen for the local port.

This test prevents two TCP connections to the same foreign address and foreign port from the same local address and local port. For example, if we establish a TCP connection with the echo server on the host *sun* and then try to establish another connection to the same server from the same local port (8888, specified with the *-b* option), the call to *in\_pcblookup* returns a match, causing *connect* to return the error *EADDRINUSE*. (We use the *sock* program from Appendix C of Volume 1.)

```
bsdi $ sock -b 8888 sun echo &          start first one in the background
bsdi $ sock -A -b 8888 sun echo         then try again
connect() error: Address already in use
```

We specify the *-A* option to set the *SO\_REUSEADDR* socket option, which lets the bind succeed, but the *connect* cannot succeed. This is a contrived example, as we explicitly bound the same local port (8888) to both sockets. In the normal scenario of two different clients from the host *bsdi* to the echo server on the host *sun*, the local port will be 0 when the second client calls *in\_pcblookup* from Figure 22.28.

This test also prevents two UDP sockets from being connected to the same foreign address from the same local port. This test does not prevent two UDP sockets from alternately sending datagrams to the same foreign address from the same local port, as long as neither calls *connect*, since a UDP socket is only temporarily connected to a peer for the duration of a *sendto* system call.

#### Implicit bind and assignment of ephemeral port

234-238 If the local address is still wildcarded for the socket, it is set to the value saved in *ifaddr*. This is an implicit bind: cases 3, 4, and 5 from the beginning of Section 22.7. First a check is made as to whether the local port has been bound yet, and if not, *in\_pcbbind* binds an ephemeral port to the socket. The order of the call to *in\_pcbbind* and the assignment to *inp\_laddr* is important, since *in\_pcbbind* fails if the local address is not the wildcard address.

#### Store foreign address and foreign port in PCB

239-240 The final step of this function sets the foreign IP address and foreign port number in the PCB. We are guaranteed, on successful return from this function, that both socket pairs in the PCB—the local and foreign—are filled in with specific values.

#### IP Source Address Versus Outgoing Interface Address

There is a subtle difference between the source address in the IP datagram versus the IP address of the interface used to send the datagram.

The PCB member *inp\_laddr* is used by TCP and UDP as the source address of the IP datagram. It can be set by the process to the IP address of *any* configured interface by bind. (The call to *ifa\_ifwithaddr* in *in\_pcbbind* verifies the local address desired by the application.) *in\_pcbconnect* assigns the local address only if it is a wildcard, and when this happens the local address is based on the outgoing interface (since the destination address is known).

22.

2:



The outgoing interface, however, is also determined by `ip_output` based on the destination IP address. On a multihomed host it is possible for the source address to be a local interface that is not the outgoing interface, when the process explicitly binds a local address that differs from the outgoing interface. This is allowed because Net/3 chooses the weak end system model (Section 8.4).

## 22.9 `in_pcbdisconnect` Function

A UDP socket is disconnected by `in_pcbdisconnect`. This removes the foreign association by setting the foreign IP address to all 0s (`INADDR_ANY`) and foreign port number to 0.

This is done after a datagram has been sent on an unconnected UDP socket and when `connect` is called on a connected UDP socket. In the first case the sequence of steps when the process calls `sendto` is: UDP calls `in_pcbconnect` to connect the socket temporarily to the destination, `udp_output` sends the datagram, and then `in_pcbdisconnect` removes the temporary connection.

`in_pcbdisconnect` is not called when a socket is closed since `in_pcbdetach` handles the release of the PCB. A disconnect is required only when the PCB needs to be reused for a different foreign address or port number.

Figure 22.29 shows the function `in_pcbdisconnect`.

```

243 int
244 in_pcbdisconnect(inp)
245 struct inpcb *inp;
246 {
247     inp->inp_faddr.s_addr = INADDR_ANY;
248     inp->inp_fport = 0;
249     if (inp->inp_socket->so_state & SS_NOFDREF)
250         in_pcbdetach(inp);
251 }

```

*in\_pcb.c*

Figure 22.29 `in_pcbdisconnect` function: disconnect from foreign address and port number.

If there is no longer a file table reference for this PCB (`SS_NOFDREF` is set) then `in_pcbdetach` (Figure 22.7) releases the PCB.

## 22.10 `in_setsockaddr` and `in_setpeeraddr` Functions

The `getsockname` system call returns the local protocol address of a socket (e.g., the IP address and port number for an Internet socket) and the `getpeername` system call returns the foreign protocol address. Both system calls end up issuing a `PRU_SOCKADDR` request or a `PRU_PEERADDR` request. The protocol then calls either `in_setsockaddr` or `in_setpeeraddr`. We show the first of these in Figure 22.30.

```

267 int
268 in_setsockaddr(inp, nam)
269 struct inpcb *inp;
270 struct mbuf *nam;
271 {
272     struct sockaddr_in *sin;
273     nam->m_len = sizeof(*sin);
274     sin = mtod(nam, struct sockaddr_in *);
275     bzero((caddr_t) sin, sizeof(*sin));
276     sin->sin_family = AF_INET;
277     sin->sin_len = sizeof(*sin);
278     sin->sin_port = inp->inp_lport;
279     sin->sin_addr = inp->inp_laddr;
280 }

```

Figure 22.30 `in_setsockaddr` function: return local address and port number.

The argument `nam` is a pointer to an mbuf that will hold the result: a `sockaddr_in` structure that the system call copies back to the process. The code fills in the socket address structure and copies the IP address and port number from the Internet PCB into the `sin_addr` and `sin_port` members.

Figure 22.31 shows the `in_setpeeraddr` function. It is nearly identical to Figure 22.30, but copies the foreign IP address and port number from the PCB.

```

281 int
282 in_setpeeraddr(inp, nam)
283 struct inpcb *inp;
284 struct mbuf *nam;
285 {
286     struct sockaddr_in *sin;
287     nam->m_len = sizeof(*sin);
288     sin = mtod(nam, struct sockaddr_in *);
289     bzero((caddr_t) sin, sizeof(*sin));
290     sin->sin_family = AF_INET;
291     sin->sin_len = sizeof(*sin);
292     sin->sin_port = inp->inp_fport;
293     sin->sin_addr = inp->inp_faddr;
294 }

```

Figure 22.31 `in_setpeeraddr` function: return foreign address and port number.

## 22.11 `in_pcbnotify`, `in_rtchange`, and `in_losing` Functions

The function `in_pcbnotify` is called when an ICMP error is received, in order to notify the appropriate process of the error. The “appropriate process” is found by searching all the PCBs for one of the protocols (TCP or UDP) and comparing the local

and foreign IP addresses and port numbers with the values returned in the ICMP error. For example, when an ICMP source quench error is received in response to a TCP segment that some router discarded, TCP must locate the PCB for the connection that caused the error and slow down the transmission on that connection.

Before showing the function we must review how it is called. Figure 22.32 summarizes the functions called to process an ICMP error. The two shaded ellipses are the functions described in this section.

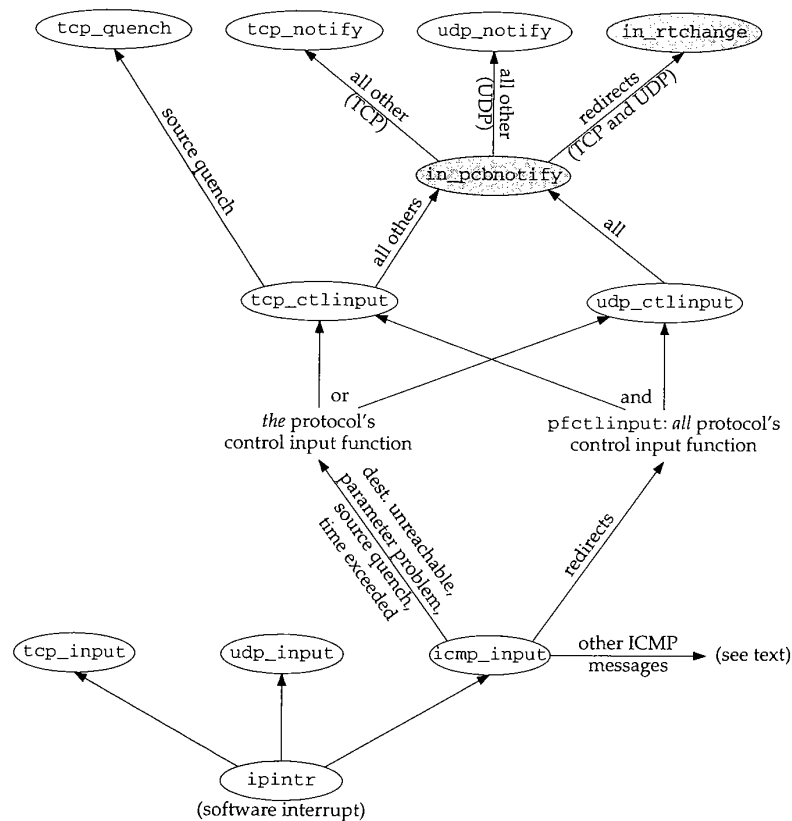

Figure 22.32 Summary of processing of ICMP errors.

When an ICMP message is received, `icmp_input` is called. Five of the ICMP messages are classified as errors (Figures 11.1 and 11.2):

- destination unreachable,
- parameter problem,
- redirect,
- source quench, and
- time exceeded.

Redirects are handled differently from the other four errors. All other ICMP messages (the queries) are handled as described in Chapter 11.

Each protocol defines its control input function, the `pr_ctlinput` entry in the `protosw` structure (Section 7.4). The ones for TCP and UDP are named `tcp_ctlinput` and `udp_ctlinput`, and we'll show their code in later chapters. Since the ICMP error that is received contains the IP header of the datagram that caused the error, the protocol that caused the error (TCP or UDP) is known. Four of the five ICMP errors cause that protocol's control input function to be called. Redirects are handled differently: the function `pfctlinput` is called, and it in turn calls the control input functions for *all* the protocols in the family (Internet). TCP and UDP are the only protocols in the Internet family with control input functions.

Redirects are handled specially because they affect *all* IP datagrams going to that destination, not just the one that caused the redirect. On the other hand, the other four errors need only be processed by the protocol that caused the error.

The final points we need to make about Figure 22.32 are that TCP handles source quenches differently from the other errors, and redirects are handled specially by `in_pcbnotify`: the function `in_rtchange` is called, regardless of the protocol that caused the error.

Figure 22.33 shows the `in_pcbnotify` function. When it is called by TCP, the first argument is the address of `tcb` and the final argument is the address of the function `tcp_notify`. For UDP, these two arguments are the address of `udb` and the address of the function `udp_notify`.

#### Verify arguments

306-324 The `cmd` argument and the address family of the destination are verified. The foreign address is checked to ensure it is not 0.0.0.0.

#### Handle redirects specially

325-338 If the error is a redirect it is handled specially. (The error `PRC_HOSTDEAD` is an old error that was generated by the IMPs. Current systems should never see this error—it is a historical artifact.) The foreign port, local port, and local address are all set to 0 so that the `for` loop that follows won't compare them. For a redirect we want that loop to select the PCBs to receive notification based only on the foreign IP address, because that is the IP address for which our host received a redirect. Also, the function that is called for a redirect is `in_rtchange` (Figure 22.34) instead of the `notify` argument specified by the caller.

339 The global array `inetctlerrmap` maps one of the protocol-independent error codes (the `PRC_XXX` values from Figure 11.19) into its corresponding Unix `errno` value (the final column in Figure 11.1).

```

306 int
307 in_pcbnotify(head, dst, fport_arg, laddr, lport_arg, cmd, notify)
308 struct inpcb *head;
309 struct sockaddr *dst;
310 u_int fport_arg, lport_arg;
311 struct in_addr laddr;
312 int cmd;
313 void (*notify) (struct inpcb *, int);
314 {
315     extern u_char inetctlerrmap[];
316     struct inpcb *inp, *oinp;
317     struct in_addr faddr;
318     u_short fport = fport_arg, lport = lport_arg;
319     int errno;
320     if ((unsigned) cmd > PRC_NCMDS || dst->sa_family != AF_INET)
321         return;
322     faddr = ((struct sockaddr_in *) dst)->sin_addr;
323     if (faddr.s_addr == INADDR_ANY)
324         return;
325     /*
326     * Redirects go to all references to the destination,
327     * and use in_rtchange to invalidate the route cache.
328     * Dead host indications: notify all references to the destination.
329     * Otherwise, if we have knowledge of the local port and address,
330     * deliver only to that socket.
331     */
332     if (PRC_IS_REDIRECT(cmd) || cmd == PRC_HOSTDEAD) {
333         fport = 0;
334         lport = 0;
335         laddr.s_addr = 0;
336         if (cmd != PRC_HOSTDEAD)
337             notify = in_rtchange;
338     }
339     errno = inetctlerrmap[cmd];
340     for (inp = head->inp_next; inp != head;) {
341         if (inp->inp_faddr.s_addr != faddr.s_addr ||
342             inp->inp_socket == 0 ||
343             (lport && inp->inp_lport != lport) ||
344             (laddr.s_addr && inp->inp_laddr.s_addr != laddr.s_addr) ||
345             (fport && inp->inp_fport != fport)) {
346             inp = inp->inp_next;
347             continue; /* skip this PCB */
348         }
349         oinp = inp;
350         inp = inp->inp_next;
351         if (notify)
352             (*notify) (oinp, errno);
353     }
354 }

```

Figure 22.33 in\_pcbnotify function: pass error notification to processes.

**Call notify function for selected PCBs**

340-353 This loop selects the PCBs to be notified. Multiple PCBs can be notified—the loop keeps going even after a match is located. The first `if` statement combines five tests, and if any one of the five is true, the PCB is skipped: (1) if the foreign addresses are unequal, (2) if the PCB does not have a corresponding socket structure, (3) if the local ports are unequal, (4) if the local addresses are unequal, or (5) if the foreign ports are unequal. The foreign addresses *must* match, while the other three foreign and local elements are compared only if the corresponding argument is nonzero. When a match is found, the `notify` function is called.

**in\_rtchange Function**

We saw that `in_pcbnotify` calls the function `in_rtchange` when the ICMP error is a redirect. This function is called for all PCBs with a foreign address that matches the IP address that has been redirected. Figure 22.34 shows the `in_rtchange` function.

```

391 void
392 in_rtchange(inp, errno)
393 struct inpcb *inp;
394 int      errno;
395 {
396     if (inp->inp_route.ro_rt) {
397         rtfree(inp->inp_route.ro_rt);
398         inp->inp_route.ro_rt = 0;
399         /*
400          * A new route can be allocated the next time
401          * output is attempted.
402          */
403     }
404 }

```

in\_pcb.c

in\_pcb.c

Figure 22.34 `in_rtchange` function: invalidate route.

If the PCB holds a route, that route is released by `rtfree`, and the PCB member is marked as empty. We don't try to update the route at this time, using the new router address returned in the redirect. The new route will be allocated by `ip_output` when this PCB is used next, based on the kernel's routing table, which is updated by the `redirect`, before `pfctlinput` is called.

**Redirects and Raw Sockets**

Let's examine the interaction of redirects, raw sockets, and the cached route in the PCB. If we run the Ping program, which uses a raw socket, and an ICMP redirect error is received for the IP address being pinged, Ping continues using the original route, not the redirected route. We can see this as follows.

We ping the host `svr4` on the 140.252.13 network from the host `gemini` on the 140.252.1 network. The default router for `gemini` is `gateway`, but the packets should be sent to the router `netb` instead. Figure 22.35 shows the arrangement.

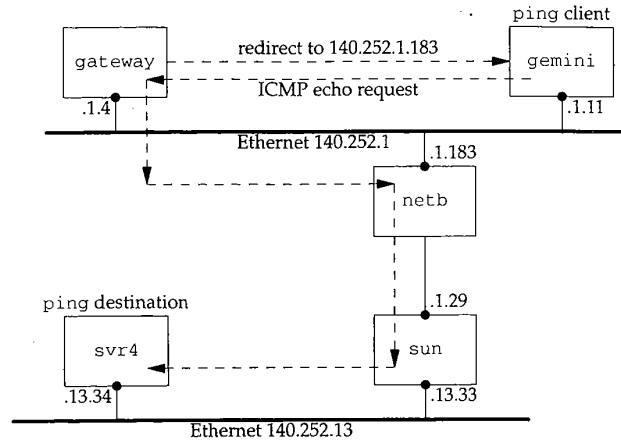

Figure 22.35 Example of ICMP redirect.

We expect gateway to send a redirect when it receives the first ICMP echo request.

```
gemini $ ping -sv svr4
PING 140.252.13.34: 56 data bytes
ICMP Host redirect from gateway 140.252.1.4
  to netb (140.252.1.183) for svr4 (140.252.13.34)
64 bytes from svr4 (140.252.13.34): icmp_seq=0. time=572. ms
ICMP Host redirect from gateway 140.252.1.4
  to netb (140.252.1.183) for svr4 (140.252.13.34)
64 bytes from svr4 (140.252.13.34): icmp_seq=1. time=392. ms
```

The `-s` option causes an ICMP echo request to be sent once a second, and the `-v` option prints every received ICMP message (instead of only the ICMP echo replies).

Every ICMP echo request elicits a redirect, but the raw socket used by ping never notices the redirect to change the route that it is using. The route that is first calculated and stored in the PCB, causing the IP datagrams to be sent to the router gateway (140.252.1.4), should be updated so that the datagrams are sent to the router netb (140.252.1.183) instead. We see that the ICMP redirects are received by the kernel on gemini, but they appear to be ignored.

If we terminate the program and start it again, we never see a redirect:

```
gemini $ ping -sv svr4
PING 140.252.13.34: 56 data bytes
64 bytes from svr4 (140.252.13.34): icmp_seq=0. time=388. ms
64 bytes from svr4 (140.252.13.34): icmp_seq=1. time=363. ms
```

The reason for this anomaly is that the raw IP socket code (Chapter 32) does not have a control input function. Only TCP and UDP have a control input function. When the redirect error is received, ICMP updates the kernel's routing table accordingly, and `pfctlinput` is called (Figure 22.32). But since there is no control input function for the raw IP protocol, the cached route in the PCB associated with Ping's raw socket is never released. When we start the Ping program a second time, however, the route that is allocated is based on the kernel's updated routing table, and we never see the redirects.

## ICMP Errors and UDP Sockets

One confusing part of the sockets API is that ICMP errors received on a UDP socket are not passed to the application unless the application has issued a `connect` on the socket, restricting the foreign IP address and port number for the socket. We now see where this limitation is enforced by `in_pcbnotify`.

Consider an ICMP port unreachable, probably the most common ICMP error on a UDP socket. The foreign IP address and the foreign port number in the `dst` argument to `in_pcbnotify` are the IP address and port number that caused the ICMP error. But if the process has not issued a `connect` on the socket, the `inp_faddr` and `inp_fport` members of the PCB are both 0, preventing `in_pcbnotify` from ever calling the `notify` function for this socket. The `for` loop in Figure 22.33 will skip every UDP PCB.

This limitation arises for two reasons. First, if the sending process has an unconnected UDP socket, the only nonzero element in the socket pair is the local port. (This assumes the process did not call `bind`.) This is the only value available to `in_pcbnotify` to demultiplex the incoming ICMP error and pass it to the correct process. Although unlikely, there could be multiple processes bound to the same local port, making it ambiguous which process should receive the error. There's also the possibility that the process that sent the datagram that caused the ICMP error has terminated, with another process then starting and using the same local port. This is also unlikely since ephemeral ports are assigned in sequential order from 1024 to 5000 and reused only after cycling around (Figure 22.23).

The second reason for this limitation is because the error notification from the kernel to the process—an `errno` value—is inadequate. Consider a process that calls `sendto` on an unconnected UDP socket three times in a row, sending a UDP datagram to three different destinations, and then waits for the replies with `recvfrom`. If one of the datagrams generates an ICMP port unreachable error, and if the kernel were to return the corresponding error (`ECONNREFUSED`) to the `recvfrom` that the process issued, the `errno` value doesn't tell the process which of the three datagrams caused the error. The kernel has all the information required in the ICMP error, but the sockets API doesn't provide a way to return this to the process.

Therefore the design decision was made that if a process wants to be notified of these ICMP errors on a UDP socket, that socket must be connected to a single peer. If the error `ECONNREFUSED` is returned on that connected socket, there's no question which peer generated the error.

There is still a remote possibility of an ICMP error being delivered to the wrong process. One process sends the UDP datagram that elicits the ICMP error, but it terminates before the error is received. Another process then starts up before the error is received, binds the same local port, and connects to the same foreign address and foreign port, causing this new process to receive the error. There's no way to prevent this from occurring, given UDP's lack of memory. We'll see that TCP handles this with its `TIME_WAIT` state.

i



In our preceding example, one way for the application to get around this limitation is to use three connected UDP sockets instead of one unconnected socket, and call `select` to determine when any one of the three has a received datagram or an error to be read.

Here we have a scenario where the kernel has the information but the API (sockets) is inadequate. With most implementations of Unix System V and the other popular API (TLI), the reverse is true: the TLI function `t_rcvuderr` can return the peer's IP address, port number, and an error value, but most SVR4 streams implementations of TCP/IP don't provide a way for ICMP to pass the error to an unconnected UDP end point.

In an ideal world, `in_pcbnotify` delivers the ICMP error to all UDP sockets that match, even if the only nonwildcard match is the local port. The error returned to the process would include the destination IP address and destination UDP port that caused the error, allowing the process to determine if the error corresponds to a datagram sent by the process.

### in\_losing Function

The final function dealing with PCBs is `in_losing`, shown in Figure 22.36. It is called by TCP when its retransmission timer has expired four or more times in a row for a given connection (Figure 25.26).

```

361 int
362 in_losing(inp)
363 struct inpcb *inp;
364 {
365     struct rtentry *rt;
366     struct rt_addrinfo info;
367     if ((rt = inp->inp_route.ro_rt) {
368         inp->inp_route.ro_rt = 0;
369         bzero((caddr_t) & info, sizeof(info));
370         info.rti_info[RTAX_DST] =
371             (struct sockaddr *) &inp->inp_route.ro_dst;
372         info.rti_info[RTAX_GATEWAY] = rt->rt_gateway;
373         info.rti_info[RTAX_NETMASK] = rt_mask(rt);
374         rt_missmsg(RTM_LOSING, &info, rt->rt_flags, 0);
375         if (rt->rt_flags & RTF_DYNAMIC)
376             (void) rtrequest(RTM_DELETE, rt_key(rt),
377                             rt->rt_gateway, rt_mask(rt), rt->rt_flags,
378                             (struct rtentry **) 0);
379         else
380             /*
381              * A new route can be allocated
382              * the next time output is attempted.
383              */
384             rtfree(rt);
385     }
386 }

```

*in\_pcb.c*

Figure 22.36 `in_losing` function: invalidate cached route information.

**Generate routing message**

361-374 If the PCB holds a route, that route is discarded. An `rt_addrinfo` structure is filled in with information about the cached route that appears to be failing. The function `rt_missmsg` is then called to generate a message from the routing socket of type `RTM_LOSING`, indicating a problem with the route.

**Delete or release route**

375-384 If the cached route was generated by a redirect (`RTF_DYNAMIC` is set), the route is deleted by calling `rtrequest` with a request of `RTM_DELETE`. Otherwise the cached route is released, causing the next output on the socket to allocate another route to the destination—hopefully a better route.

## 22.12 Implementation Refinements

Undoubtedly the most time-consuming algorithm we've encountered in this chapter is the linear searching of the PCBs done by `in_pcblookup`. At the beginning of Section 22.6 we noted four instances when this function is called. We can ignore the calls to `bind` and `connect`, as they occur much less frequently than the calls to `in_pcblookup` from TCP and UDP, to demultiplex every received IP datagram.

In later chapters we'll see that TCP and UDP both try to help this linear search by maintaining a pointer to the last PCB that the protocol referenced: a one-entry cache. If the local address, local port, foreign address, and foreign port in the cached PCB match the values in the received datagram, the protocol doesn't even call `in_pcblookup`. If the protocol's data fits the packet train model [Jain and Routhier 1986], this simple cache works well. But if the data does not fit this model and, for example, looks like data entry into an on-line transaction processing system, the one-entry cache performs poorly [McKenney and Dove 1992].

One proposal for a better PCB arrangement is to move a PCB to the front of the PCB list when the PCB is referenced. ([McKenney and Dove 1992] attribute this idea to Jon Crowcroft; [Partridge and Pink 1993] attribute it to Gary Delp.) This movement of the PCB is easy to do since it is a doubly linked list and a pointer to the head of the list is the first argument to `in_pcblookup`.

[McKenney and Dove 1992] compare the original Net/1 implementation (no cache), an enhanced one-entry send-receive cache, the move-to-the-front heuristic, and their own algorithm that uses hash chains. They show that maintaining a linear list of PCBs on hash chains provides an order of magnitude improvement over the other algorithms. The only cost for the hash chains is the memory required for the hash chain headers and the computation of the hash function. They also consider adding the move-to-the-front heuristic to their hash-chain algorithm and conclude that it is easier simply to add more hash chains.

Another comparison of the BSD linear search to a hash table search is in [Hutchinson and Peterson 1991]. They show that the time required to demultiplex an incoming UDP datagram is constant as the number of sockets increases for a hash table, but with a linear search the time increases as the number of sockets increases.

## 22.13 Summary

An Internet PCB is associated with every Internet socket: TCP, UDP, and raw IP. It contains information common to all Internet sockets: local and foreign IP addresses, pointer to a route structure, and so on. All the PCBs for a given protocol are placed on a doubly linked list maintained by that protocol.

In this chapter we've looked at numerous functions that manipulate the PCBs, and three in detail.

1. `in_pcblookup` is called by TCP and UDP to demultiplex every received datagram. It chooses which socket receives the datagram, taking into account wildcard matches.

This function is also called by `in_pcbbind` to verify that the local address and local process are unique, and by `in_pcbconnect` to verify that the combination of a local address, local process, foreign address, and foreign process are unique.

2. `in_pcbbind` explicitly or implicitly binds a local address and local port to a socket. An explicit bind occurs when the process calls `bind`, and an implicit bind occurs when a TCP client calls `connect` without calling `bind`, or when a UDP process calls `sendto` or `connect` without calling `bind`.
3. `in_pcbconnect` sets the foreign address and foreign process. If the local address has not been set by the process, a route to the foreign address is calculated and the resulting local interface becomes the local address. If the local port has not been set by the process, `in_pcbbind` chooses an ephemeral port for the socket.

Figure 22.37 summarizes the common scenarios for various TCP and UDP applications and the values stored in the PCB for the local address and port and the foreign address and port. We have not yet covered all the actions shown in Figure 22.37 for TCP and UDP processes, but will examine the code in later chapters.

Application	local address: inp_laddr	local port: inp_lport	foreign address: inp_faddr	foreign port: inp_fport
TCP client: connect ( <i>foreignIP</i> , <i>fport</i> )	in_pcbconnect calls rttalloc to allocate route to <i>foreignIP</i> . Local address is local interface.	in_pcbconnect calls in_pcbbind to choose ephemeral port.	<i>foreignIP</i>	<i>fport</i>
TCP client: bind ( <i>localIP</i> , <i>lport</i> ) connect ( <i>foreignIP</i> , <i>fport</i> )	<i>localIP</i>	<i>lport</i>	<i>foreignIP</i>	<i>fport</i>
TCP client: bind (*, <i>lport</i> ) connect ( <i>foreignIP</i> , <i>fport</i> )	in_pcbconnect calls rttalloc to allocate route to <i>foreignIP</i> . Local address is local interface.	<i>lport</i>	<i>foreignIP</i>	<i>fport</i>
TCP client: bind ( <i>localIP</i> , 0) connect ( <i>foreignIP</i> , <i>fport</i> )	<i>localIP</i>	in_pcbbind chooses ephemeral port.	<i>foreignIP</i>	<i>fport</i>
TCP server: bind ( <i>localIP</i> , <i>lport</i> ) listen() accept()	<i>localIP</i>	<i>lport</i>	Source address from IP header.	Source port from TCP header.
TCP server: bind (*, <i>lport</i> ) listen() accept()	Destination address from IP header.	<i>lport</i>	Source address from IP header.	Source port from TCP header.
UDP client: sendto ( <i>foreignIP</i> , <i>fport</i> )	in_pcbconnect calls rttalloc to allocate route to <i>foreignIP</i> . Local address is local interface. Reset to 0.0.0.0 after datagram sent.	in_pcbconnect calls in_pcbbind to choose ephemeral port. Not changed on subsequent calls to sendto.	<i>foreignIP</i> . Reset to 0.0.0.0 after datagram sent.	<i>fport</i> . Reset to 0 after datagram sent.
UDP client: connect ( <i>foreignIP</i> , <i>fport</i> ) write()	in_pcbconnect calls rttalloc to allocate route to <i>foreignIP</i> . Local address is local interface. Not changed on subsequent calls to write.	in_pcbconnect calls in_pcbbind to choose ephemeral port. Not changed on subsequent calls to write.	<i>foreignIP</i>	<i>fport</i>

Figure 22.37 Summary of in\_pcbbind and in\_pcbconnect.

## Exercises

- 22.1 What happens in Figure 22.23 when the process asks for an ephemeral port and every ephemeral port is in use?
- 22.2 In Figure 22.10 we showed two Telnet servers with listening sockets: one with a specific local IP address and one with the wildcard for its local IP address. Does your system's Telnet daemon allow you to specify the local IP address, and if so, how?
- 22.3 Assume a socket is bound to the local socket {140.252.1.29, 8888}, and this is the only socket using local port 8888. (1) Go through the steps performed by `in_pcbbind` when another socket is bound to {140.252.13.33, 8888}, without any socket options. (2) Go through the steps performed when another socket is bound to the wildcard IP address, port 8888, without any socket options. (3) Go through the steps performed when another socket is bound to the wildcard IP address, port 8888, with the `SO_REUSEADDR` socket option.
- 22.4 What is the first ephemeral port number allocated by UDP?
- 22.5 When a process calls `bind`, which elements in the `sockaddr_in` structure must be filled in?
- 22.6 What happens if a process tries to `bind` a local broadcast address? What happens if a process tries to `bind` the limited broadcast address (255.255.255.255)?

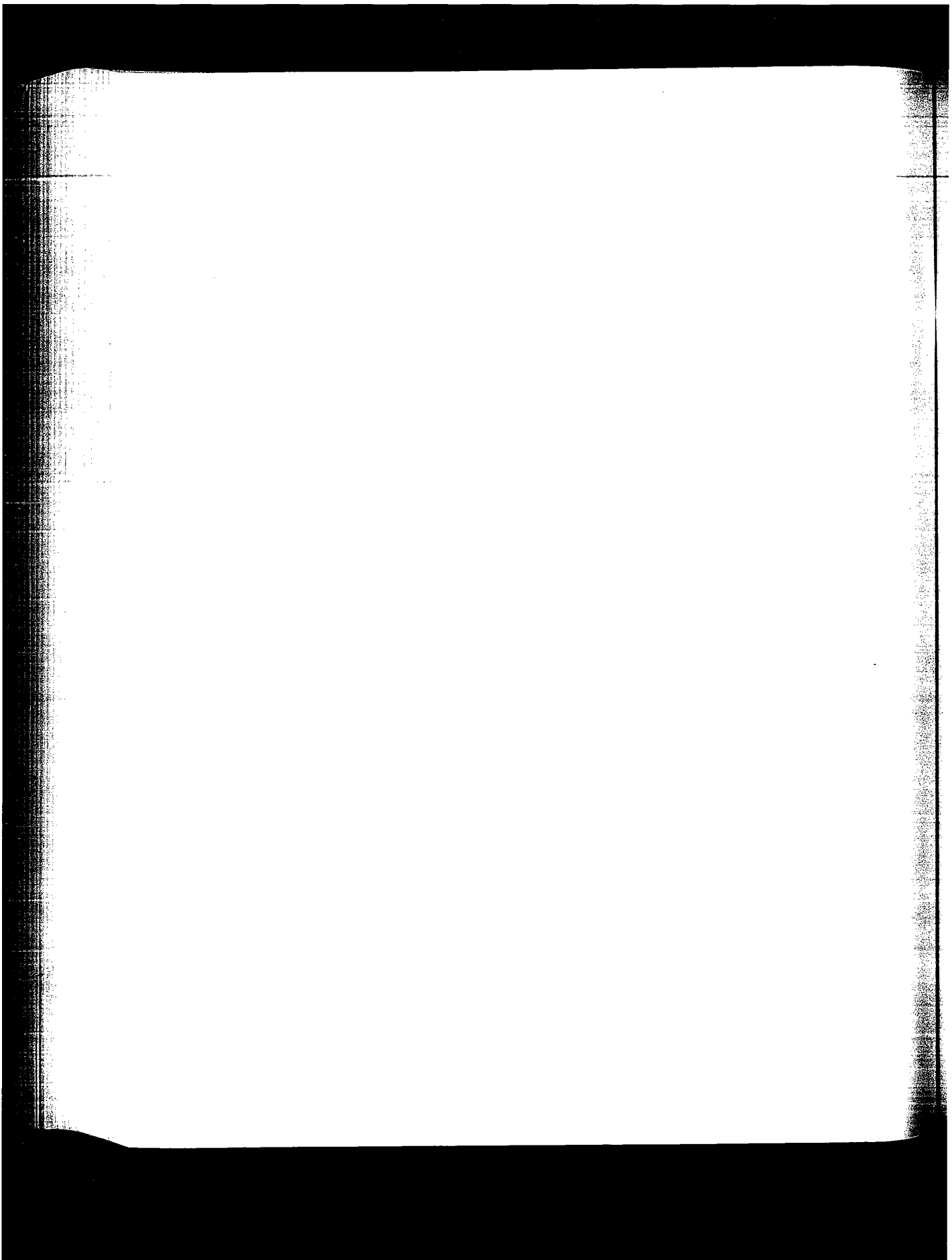

## ***UDP: User Datagram Protocol***

### **23.1 Introduction**

The User Datagram Protocol, or UDP, is a simple, datagram-oriented, transport-layer protocol: each output operation by a process produces exactly one UDP datagram, which causes one IP datagram to be sent.

A process accesses UDP by creating a socket of type `SOCK_DGRAM` in the Internet domain. By default the socket is termed *unconnected*. Each time the process sends a datagram it must specify the destination IP address and port number. Each time a datagram is received for the socket, the process can receive the source IP address and port number from the datagram.

We mentioned in Section 22.5 that a UDP socket can also be *connected* to one particular IP address and port number. This causes all datagrams written to the socket to go to that destination, and only datagrams arriving from that IP address and port number are passed to the process.

This chapter examines the implementation of UDP.

### **23.2 Code Introduction**

There are nine UDP functions in a single C file and various UDP definitions in two headers, as shown in Figure 23.1.

Figure 23.2 shows the relationship of the six main UDP functions to other kernel functions. The shaded ellipses are the six functions that we cover in this chapter. We also cover three additional UDP functions that are called by some of these six functions.

File	Description
netinet/udp.h	udphdr structure definition
netinet/udp_var.h	other UDP definitions
netinet/udp_usrreq.c	UDP functions

Figure 23.1 Files discussed in this chapter.

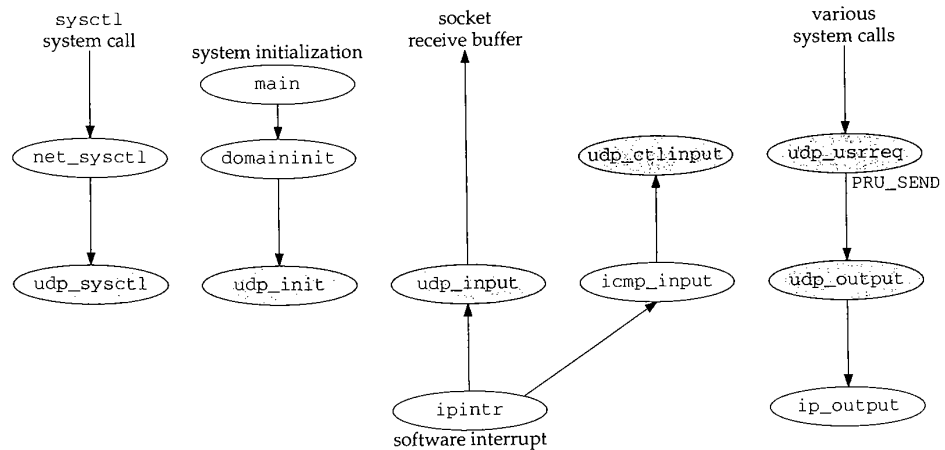

Figure 23.2 Relationship of UDP functions to rest of kernel.

### Global Variables

Seven global variables are introduced in this chapter, which are shown in Figure 23.3.

Variable	Datatype	Description
udb	struct inpcb	head of the UDP PCB list
udp_last_inpcb	struct inpcb *	pointer to PCB for last received datagram: one-behind cache
udpcksum	int	flag for calculating and verifying UDP checksum
udp_in	struct sockaddr_in	holds sender's IP address and port on input
udpstat	struct udpstat	UDP statistics (Figure 23.4)
udp_recvspace	u_long	default size of socket receive buffer, 41,600 bytes
udp_sendspace	u_long	default size of socket send buffer, 9216 bytes

Figure 23.3 Global variables introduced in this chapter.



## Statistics

Various UDP statistics are maintained in the global structure `udpstat`, described in Figure 23.4. We'll see where these counters are incremented as we proceed through the code.

udpstat member	Description	Used by SNMP
<code>udps_badlen</code>	#received datagrams with data length larger than packet	•
<code>udps_badsum</code>	#received datagrams with checksum error	•
<code>udps_fullsock</code>	#received datagrams not delivered because input socket full	•
<code>udps_hdrops</code>	#received datagrams with packet shorter than header	•
<code>udps_ipackets</code>	total #received datagrams	•
<code>udps_noport</code>	#received datagrams with no process on destination port	•
<code>udps_noportbcst</code>	#received broadcast/multicast datagrams with no process on dest. port	•
<code>udps_opackets</code>	total #output datagrams	•
<code>udpps_pcbcachemiss</code>	#received input datagrams missing pcb cache	

Figure 23.4 UDP statistics maintained in the `udpstat` structure.

Figure 23.5 shows some sample output of these statistics, from the `netstat -s` command.

netstat -s output	udpstat member
18,575,142 datagrams received	<code>udps_ipackets</code>
0 with incomplete header	<code>udps_hdrops</code>
18 with bad data length field	<code>udps_badlen</code>
58 with bad checksum	<code>udps_badsum</code>
84,079 dropped due to no socket	<code>udps_noport</code>
446 broadcast/multicast datagrams dropped due to no socket	<code>udps_noportbcst</code>
5,356 dropped due to full socket buffers	<code>udps_fullsock</code>
18,485,185 delivered	(see text)
18,676,277 datagrams output	<code>udps_opackets</code>

Figure 23.5 Sample UDP statistics.

The number of UDP datagrams delivered (the second from last line of output) is the number of datagrams received (`udps_ipackets`) minus the six variables that precede it in Figure 23.5.

## SNMP Variables

Figure 23.6 shows the four simple SNMP variables in the UDP group and which counters from the `udpstat` structure implement that variable.

Figure 23.7 shows the UDP listener table, named `udpTable`. The values returned by SNMP for this table are taken from a UDP PCB, not the `udpstat` structure.

SNMP variable	udpstat member	Description
udpInDatagrams	udps_ipackets	#received datagrams delivered to processes
udpInErrors	udps_hdrops + udps_badsum + udps_badlen	#undeliverable UDP datagrams for reasons other than no application at destination port (e.g., UDP checksum error)
udpNoPorts	udps_noport + udps_noportbcast	#received datagrams for which no application process was at the destination port
udpOutDatagrams	udps_opackets	#datagrams sent

Figure 23.6 Simple SNMP variables in udp group.

UDP listener table, index = < udpLocalAddress > . < udpLocalPort >		
SNMP variable	PCB variable	Description
udpLocalAddress	inp_laddr	local IP address for this listener
udpLocalPort	inp_lport	local port number for this listener

Figure 23.7 Variables in UDP listener table: udpTable.

### 23.3 UDP protosw Structure

Figure 23.8 lists the protocol switch entry for UDP.

Member	inetsw[1]	Description
pr_type	SOCK_DGRAM	UDP provides datagram packet services
pr_domain	&inetdomain	UDP is part of the Internet domain
pr_protocol	IPPROTO_UDP (17)	appears in the ip_p field of the IP header
pr_flags	PR_ATOMIC PR_ADDR	socket layer flags, not used by protocol processing
pr_input	udp_input	receives messages from IP layer
pr_output	0	not used by UDP
pr_ctlinput	udp_ctlinput	control input function for ICMP errors
pr_ctloutput	ip_ctloutput	respond to administrative requests from a process
pr_usrreq	udp_usrreq	respond to communication requests from a process
pr_init	udp_init	initialization for UDP
pr_fasttimo	0	not used by UDP
pr_slowtimo	0	not used by UDP
pr_drain	0	not used by UDP
pr_sysctl	udp_sysctl	for sysctl(8) system call

Figure 23.8 The UDP protosw structure.

We describe the five functions that begin with `udp_` in this chapter. We also cover a sixth function, `udp_output`, which is not in the protocol switch entry but is called by `udp_usrreq` when a UDP datagram is output.

### 23.4 UDP Header

The UDP header is defined as a `udphdr` structure. Figure 23.9 shows the C structure and Figure 23.10 shows a picture of the UDP header.

```

39 struct udphdr {
40     u_short uh_sport;      /* source port */
41     u_short uh_dport;      /* destination port */
42     short  uh_ulen;        /* udp length */
43     u_short uh_sum;        /* udp checksum */
44 };
    
```

*udp.h*

Figure 23.9 udphdr structure.

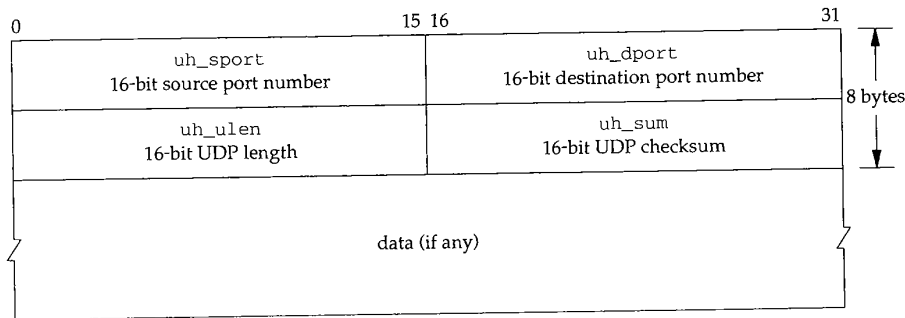

Figure 23.10 UDP header and optional data.

In the source code the UDP header is normally referenced as an IP header immediately followed by a UDP header. This is how `udp_input` processes received IP datagrams, and how `udp_output` builds outgoing IP datagrams. This combined IP/UDP header is a `udpiphdr` structure, shown in Figure 23.11.

```

38 struct udpiphdr {
39     struct ipovly ui_i;      /* overlaid ip structure */
40     struct udphdr ui_u;      /* udp header */
41 };
42 #define ui_next      ui_i.ih_next
43 #define ui_prev      ui_i.ih_prev
44 #define ui_xl        ui_i.ih_xl
45 #define ui_pr        ui_i.ih_pr
46 #define ui_len        ui_i.ih_len
47 #define ui_src        ui_i.ih_src
48 #define ui_dst        ui_i.ih_dst
49 #define ui_sport      ui_u.uh_sport
50 #define ui_dport      ui_u.uh_dport
51 #define ui_ulen        ui_u.uh_ulen
52 #define ui_sum        ui_u.uh_sum
    
```

*udp\_var.h*

Figure 23.11 udpiphdr structure: combined IP/UDP header.

The 20-byte IP header is defined as an `ipovly` structure, shown in Figure 23.12.

```

38 struct ipovly {
39     caddr_t ih_next, ih_prev; /* for protocol sequence q's */
40     u_char ih_x1; /* (unused) */
41     u_char ih_pr; /* protocol */
42     short ih_len; /* protocol length */
43     struct in_addr ih_src; /* source internet address */
44     struct in_addr ih_dst; /* destination internet address */
45 };

```

*ip\_var.h*

Figure 23.12 `ipovly` structure.

Unfortunately this structure is not a real IP header, as shown in Figure 8.8. The size is the same (20 bytes) but the fields are different. We'll return to this discrepancy when we discuss the calculation of the UDP checksum in Section 23.6.

### 23.5 `udp_init` Function

The `domaininit` function calls UDP's initialization function (`udp_init`, Figure 23.13) at system initialization time.

```

50 void
51 udp_init()
52 {
53     udb.inp_next = udb.inp_prev = &udb;
54 }

```

*udp\_usrreq.c*

Figure 23.13 `udp_init` function.

The only action performed by this function is to set the next and previous pointers in the head PCB (`udb`) to point to itself. This is an empty doubly linked list.

The remainder of the `udb` PCB is initialized to 0, although the only other field used in this head PCB is `inp_lport`, the next UDP ephemeral port number to allocate. In the solution for Exercise 22.4 we mention that because this local port number is initialized to 0, the first ephemeral port number will be 1024.

### 23.6 `udp_output` Function

UDP output occurs when the application calls one of the five write functions: `send`, `sendto`, `sendmsg`, `write`, or `writv`. If the socket is connected, any of the five functions can be called, although a destination address cannot be specified with `sendto` or `sendmsg`. If the socket is unconnected, only `sendto` and `sendmsg` can be called, and a

destination address must be specified. Figure 23.14 summarizes how these five write functions end up with `udp_output` being called, which in turn calls `ip_output`.

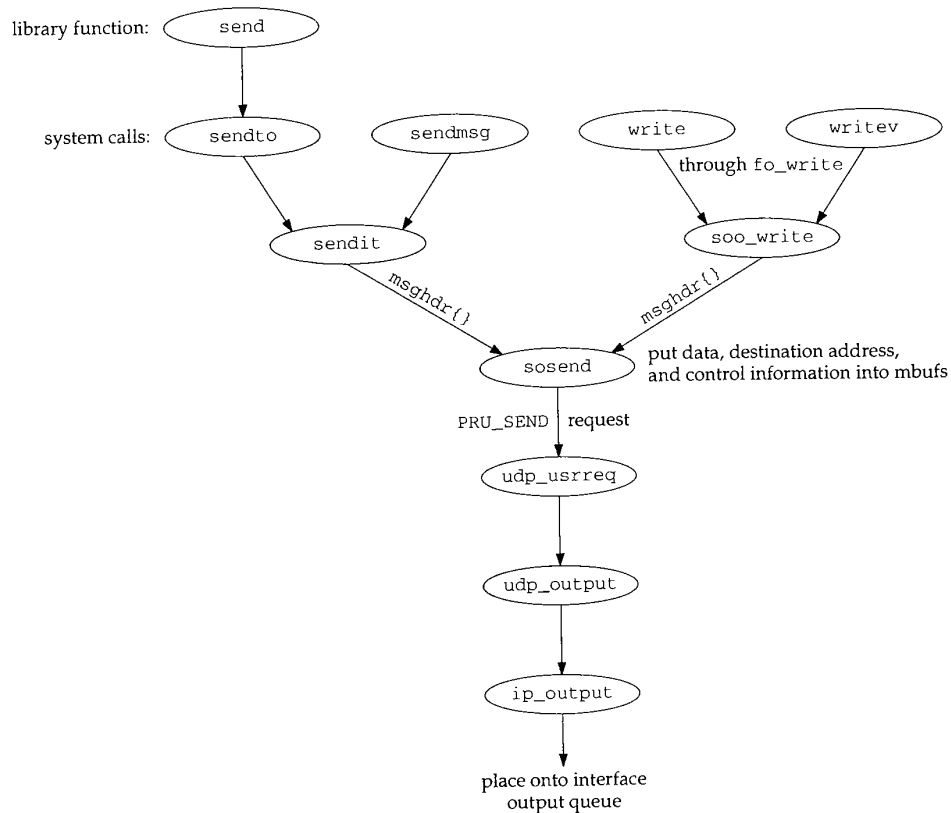

Figure 23.14 How the five write functions end up calling `udp_output`.

All five functions end up calling `sosend`, passing a pointer to a `msg_hdr` structure as an argument. The data to output is packaged into an mbuf chain and an optional destination address and optional control information are also put into mbufs by `sosend`. A `PRU_SEND` request is issued.

UDP calls the function `udp_output`, which we show the first half of in Figure 23.15. The four arguments are `inp`, a pointer to the socket Internet PCB; `m`, a pointer to the mbuf chain for output; `addr`, an optional pointer to an mbuf with the destination address packaged as a `sockaddr_in` structure; and `control`, an optional pointer to an mbuf with control information from `sendmsg`.

```

333 int
334 udp_output(inp, m, addr, control)
335 struct inpcb *inp;
336 struct mbuf *m;
337 struct mbuf *addr, *control;
338 {
339     struct udpiphdr *ui;
340     int len = m->m_pkthdr.len;
341     struct in_addr laddr;
342     int s, error = 0;

343     if (control)
344         m_freem(control); /* XXX */

345     if (addr) {
346         laddr = inp->inp_laddr;
347         if (inp->inp_faddr.s_addr != INADDR_ANY) {
348             error = EISCONN;
349             goto release;
350         }
351         /*
352          * Must block input while temporarily connected.
353          */
354         s = splnet();
355         error = in_pcbconnect(inp, addr);
356         if (error) {
357             splx(s);
358             goto release;
359         }
360     } else {
361         if (inp->inp_faddr.s_addr == INADDR_ANY) {
362             error = ENOTCONN;
363             goto release;
364         }
365     }
366     /*
367      * Calculate data length and get an mbuf for UDP and IP headers.
368      */
369     M_PREPEND(m, sizeof(struct udpiphdr), M_DONTWAIT);
370     if (m == 0) {
371         error = ENOBUFS;
372         goto release;
373     }

    /* remainder of function shown in Figure 23.20 */

409 release:
410     m_freem(m);
411     return (error);
412 }

```

Figure 23.15 udp\_output function: temporarily connect an unconnected socket.

**Discard optional control information**

333-344 Any optional control information is discarded by `m_freem`, without generating an error. UDP output does not use control information for any purpose.

The comment XXX is because the control information is ignored without generating an error. Other protocols, such as the routing domain and TCP, generate an error if the process passes control information.

**Temporarily connect an unconnected socket**

345-359 If the caller specifies a destination address for the UDP datagram (`addr` is nonnull), the socket is temporarily connected to that destination address by `in_pcbconnect`. The socket will be disconnected at the end of this function. Before doing this connect, a check is made as to whether the socket is already connected, and, if so, the error `EISCONN` is returned. This is why a `sendto` that specifies a destination address on a connected socket returns an error.

Before the socket is temporarily connected, IP input processing is stopped by `splnet`. This is done because the temporary connect changes the foreign address, foreign port, and possibly the local address in the socket's PCB. If a received UDP datagram were processed while this PCB was temporarily connected, that datagram could be delivered to the wrong process. Setting the processor priority to `splnet` only stops a software interrupt from causing the IP input routine to be executed (Figure 1.12), it does not prevent the interface layer from accepting incoming packets and placing them onto IP's input queue.

[Partridge and Pink 1993] note that this operation of temporarily connecting the socket is expensive and consumes nearly one-third of the cost of each UDP transmission.

The local address from the PCB is saved in `laddr` before temporarily connecting, because if it is the wildcard address it will be changed by `in_pcbconnect` when it calls `in_pcbbind`.

The same rules apply to the destination address that would apply if the process called `connect`, since `in_pcbconnect` is called for both cases.

360-364 If the process doesn't specify a destination address, and the socket is not connected, `ENOTCONN` is returned.

**Prepend IP and UDP headers**

366-373 `M_PREPEND` allocates room for the IP and UDP headers in front of the data. Figure 1.8 showed one scenario, assuming there is not room in the first mbuf on the chain for the 28 bytes of header. Exercise 23.1 details the other possible scenarios. The flag `M_DONTWAIT` is specified because if the socket is temporarily connected, IP processing is blocked, and `M_PREPEND` should not block.

Earlier Berkeley releases incorrectly specified `M_WAIT` here.

**Prepending IP/UDP Headers and Mbuf Clusters**

There is a subtle interaction between the `M_PREPEND` macro and mbuf clusters. If the user data is placed into a cluster by `sosend`, then 56 bytes (`max_hdr` from Figure 7.17)

are left unused at the beginning of the cluster, allowing room for the Ethernet, IP, and UDP headers. This is to prevent `M_PREPEND` from allocating another mbuf just to hold these headers. `M_PREPEND` calls `M_LEADINGSPACE` to calculate how much space is available at the beginning of the mbuf:

```
#define M_LEADINGSPACE(m) \
((m)->m_flags & M_EXT ? /* (m)->m_data - (m)->m_ext.ext_buf */ 0 : \
(m)->m_flags & M_PKTHDR ? (m)->m_data - (m)->m_pktdat : \
(m)->m_data - (m)->m_dat)
```

The code that correctly calculates the amount of room at the front of a cluster is commented out, and the macro always returns 0 if the data is in a cluster. This means that when the user data is in a cluster, `M_PREPEND` always allocates a new mbuf for the protocol headers instead of using the room allocated for this purpose by `so_send`.

The reason for commenting out the correct code in `M_LEADINGSPACE` is that the cluster might be shared (Section 2.9), and, if it is shared, using the space before the user's data in the cluster could wipe out someone else's data.

With UDP data, clusters are not shared, since `udp_output` does not save a copy of the data. TCP, however, saves a copy of the data in its send buffer (waiting for the data to be acknowledged), and if the data is in a cluster, it is shared. But `tcp_output` doesn't call `M_LEADINGSPACE`, because `so_send` leaves room for only 56 bytes at the beginning of the cluster for datagram protocols. `tcp_output` always calls `MGETHDR` instead, to allocate an mbuf for the protocol headers.

### UDP Checksum Calculation and Pseudo-Header

Before showing the last half of `udp_output` we describe how UDP fills in some of the fields in the IP/UDP headers, calculates the UDP checksum, and passes the IP/UDP headers and the data to IP for output. The way this is done with the `ipovly` structure is tricky.

Figure 23.16 shows the 28-byte IP/UDP headers that are built by `udp_output` in the first mbuf in the chain pointed to by `m`. The unshaded fields are filled in by `udp_output` and the shaded fields are filled in by `ip_output`. This figure shows the format of the headers as they appear on the wire.

The UDP checksum is calculated over three areas: (1) a 12-byte pseudo-header containing fields from the IP header, (2) the 8-byte UDP header, and (3) the UDP data. Figure 23.17 shows the 12 bytes of pseudo-header used for the checksum computation, along with the UDP header. The UDP header used for the checksum calculation is identical to the UDP header that appears on the wire (Figure 23.16).

The following three facts are used in computing the UDP checksum. (1) The third 32-bit word in the pseudo-header (Figure 23.17) looks similar to the third 32-bit word in the IP header (Figure 23.16): two 8-bit values and a 16-bit value. (2) The order of the three 32-bit values in the pseudo-header is irrelevant. Actually, the computation of the Internet checksum does not depend on the order of the 16-bit values that are used (Section 8.7). (3) Including additional 32-bit words of 0 in the checksum computation has no effect.



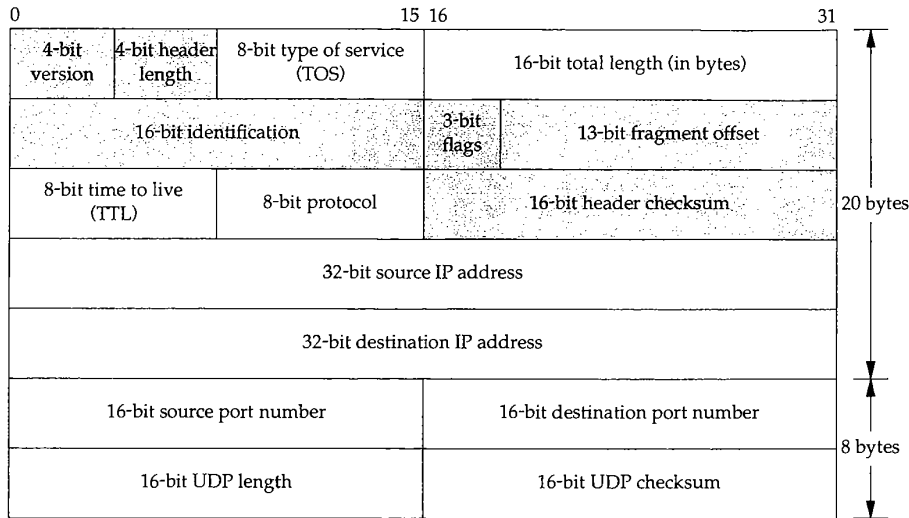

Figure 23.16 IP/UDP headers: unshaded fields filled in by UDP; shaded fields filled in by IP.

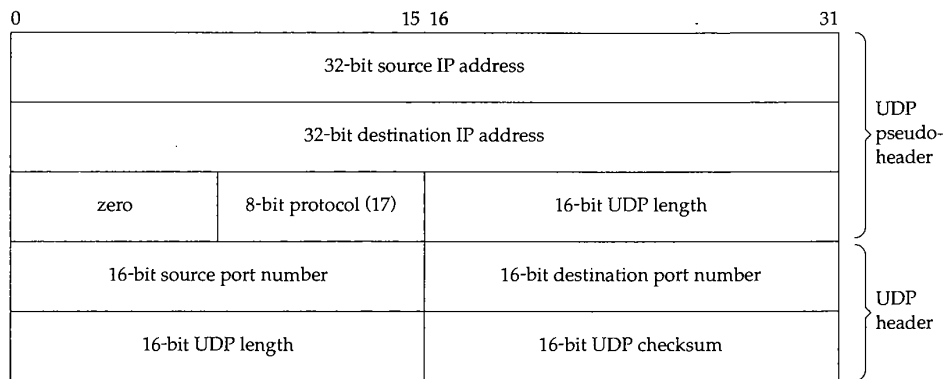

Figure 23.17 Pseudo-header used for checksum computation and UDP header.

udp\_output takes advantage of these three facts and fills in the fields in the `udpiphdr` structure (Figure 23.11), which we depict in Figure 23.18. This structure is contained in the first mbuf in the chain pointed to by the argument `m`.

The last three 32-bit words in the 20-byte IP header (the five members `ui_x1`, `ui_pr`, `ui_len`, `ui_src`, and `ui_dst`) are used as the pseudo-header for the checksum computation. The first two 32-bit words in the IP header (`ui_next` and `ui_prev`) are also used in the checksum computation, but they're initialized to 0, and don't affect the checksum.

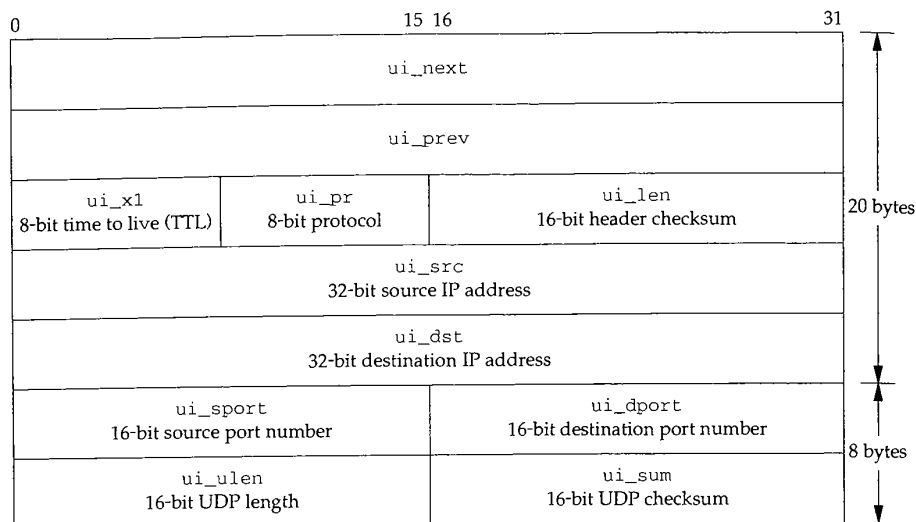

Figure 23.18 udphdr structure used by udp\_output.

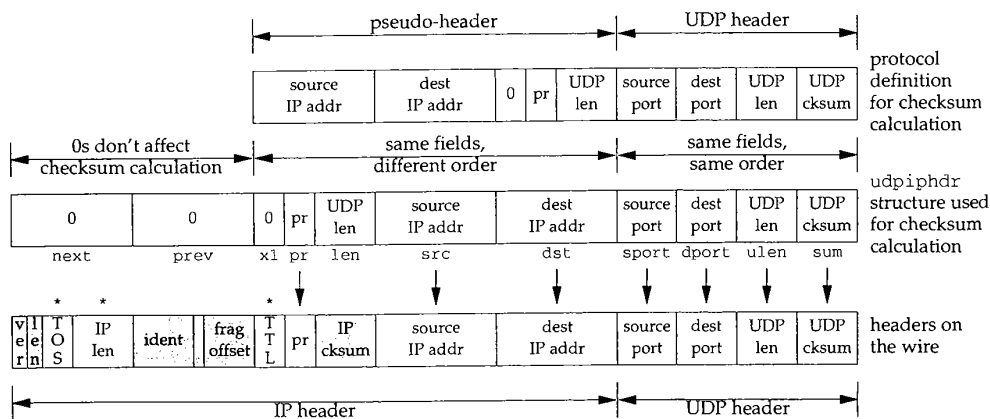

Figure 23.19 Operations to fill in IP/UDP headers and calculate UDP checksum.

Figure 23.19 summarizes the operations we've described.

1. The top picture shown in Figure 23.19 is the protocol definition of the pseudo-header, which corresponds to Figure 23.17.

2. The middle picture is the `udpiphdr` structure that is used in the source code, which corresponds to Figure 23.11. (To make the figure readable, the prefix `ui_` has been left off all the members.) This is the structure built by `udp_output` in the first mbuf and then used to calculate the UDP checksum.
3. The bottom picture shows the IP/UDP headers that appear on the wire, which corresponds to Figure 23.16. The seven fields with an arrow above are filled in by `udp_output` before the checksum computation. The three fields with an asterisk above are filled in by `udp_output` after the checksum computation. The remaining six shaded fields are filled in by `ip_output`.

Figure 23.20 shows the last half of the `udp_output` function.

```

374      /*
375      * Fill in mbuf with extended UDP header
376      * and addresses and length put into network format.
377      */
378      ui = mtod(m, struct udpiphdr *);
379      ui->ui_next = ui->ui_prev = 0;
380      ui->ui_xl = 0;
381      ui->ui_pr = IPPROTO_UDP;
382      ui->ui_len = htons((u_short) len + sizeof(struct udphdr));
383      ui->ui_src = inp->inp_laddr;
384      ui->ui_dst = inp->inp_faddr;
385      ui->ui_sport = inp->inp_lport;
386      ui->ui_dport = inp->inp_fport;
387      ui->ui_ulen = ui->ui_len;
388      /*
389      * Stuff checksum and output datagram.
390      */
391      ui->ui_sum = 0;
392      if (udpcksum) {
393          if ((ui->ui_sum = in_cksum(m, sizeof(struct udpiphdr) + len)) == 0)
394              ui->ui_sum = 0xffff;
395      }
396      ((struct ip *) ui)->ip_len = sizeof(struct udpiphdr) + len;
397      ((struct ip *) ui)->ip_ttl = inp->inp_ip.ip_ttl; /* XXX */
398      ((struct ip *) ui)->ip_tos = inp->inp_ip.ip_tos; /* XXX */
399      udpstat.udps_opackets++;
400      error = ip_output(m, inp->inp_options, &inp->inp_route,
401                      inp->inp_socket->so_options & (SO_DONTROUTE | SO_BROADCAST),
402                      inp->inp_moptions);
403      if (addr) {
404          in_pcbdisconnect(inp);
405          inp->inp_laddr = laddr;
406          splx(s);
407      }
408      return (error);

```

Figure 23.20 `udp_output` function: fill in headers, calculate checksum, pass to IP.

**Prepare pseudo-header for checksum computation**

374-387 All the members in the `udphdr` structure (Figure 23.18) are set to their respective values. The local and foreign sockets from the PCB are already in network byte order, but the UDP length must be converted to network byte order. The UDP length is the number of bytes of data (`len`, which can be 0) plus the size of the UDP header (8). The UDP length field appears twice in the UDP checksum calculation: `ui_len` and `ui_ulen`. One of them is redundant.

**Calculate checksum**

388-395 The checksum is calculated by first setting it to 0 and then calling `in_cksum`. If UDP checksums are disabled (a bad idea—see Section 11.3 of Volume 1), 0 is sent as the checksum. If the calculated checksum is 0, 16 one bits are stored in the header instead of 0. (In one's complement arithmetic, all one bits and all zero bits are both considered 0.) This allows the receiver to distinguish between a UDP packet without a checksum (the checksum field is 0) versus a UDP packet with a checksum whose value is 0 (the checksum is 16 one bits).

The variable `udpcksum` (Figure 23.3) normally defaults to 1, enabling UDP checksums. The kernel can be compiled for 4.2BSD compatibility, which initializes `udpcksum` to 0.

**Fill in UDP length, TTL, and TOS**

396-398 The pointer `ui` is cast to a pointer to a standard IP header (`ip`), and three fields in the IP header are set by UDP. The IP length field is set to the amount of data in the UDP datagram, plus 28, the size of the IP/UDP headers. Notice that this field in the IP header is stored in host byte order, not network byte order like the rest of the multibyte fields in the header. `ip_output` converts it to network byte order before transmission.

The TTL and TOS fields in the IP header are then set from the values in the socket's PCB. These values are defaulted by UDP when the socket is created, but can be changed by the process using `setsockopt`. Since these three fields—IP length, TTL, and TOS—are not part of the pseudo-header and not used in the UDP checksum computation, they must be set after the checksum is calculated but before `ip_output` is called.

**Send datagram**

400-402 `ip_output` sends the datagram. The second argument, `inp_options`, are IP options the process can set using `setsockopt`. These IP options are placed into the IP header by `ip_output`. The third argument is a pointer to the cached route in the PCB, and the fourth argument is the socket options. The only socket options that are passed to `ip_output` are `SO_DONTROUTE` (bypass the routing tables) and `SO_BROADCAST` (allow broadcasting). The final argument is a pointer to the multicast options for this socket.

**Disconnect temporarily connected socket**

403-407 If the socket was temporarily connected, `in_pcbdisconnect` disconnects the socket, the local IP address is restored in the PCB, and the interrupt level is restored to its saved value.

## 23.7 `udp_input` Function

UDP output is driven by a process calling one of the five write functions. The functions shown in Figure 23.14 are all called directly as part of the system call. UDP input, on the other hand, occurs when IP input receives an IP datagram on its input queue whose protocol field specifies UDP. IP calls the function `udp_input` through the `pr_input` function in the protocol switch table (Figure 8.15). Since IP input is at the software interrupt level, `udp_input` also executes at this level. The goal of `udp_input` is to place the UDP datagram onto the appropriate socket's buffer and wake up any process blocked for input on that socket.

We'll divide our discussion of the `udp_input` function into three sections:

1. the general validation that UDP performs on the received datagram,
2. processing UDP datagrams destined for a unicast address: locating the appropriate PCB and placing the datagram onto the socket's buffer, and
3. processing UDP datagrams destined for a broadcast or multicast address: the datagram may be delivered to multiple sockets.

This last step is new with the support of multicasting in Net/3, but consumes almost one-third of the code.

### General Validation of Received UDP Datagram

Figure 23.21 shows the first section of UDP input.

55-65 The two arguments to `udp_input` are `m`, a pointer to an mbuf chain containing the IP datagram, and `iphlen`, the length of the IP header (including possible IP options).

#### Discard IP options

67-76 If IP options are present they are discarded by `ip_stripoptions`. As the comments indicate, UDP should save a copy of the IP options and make them available to the receiving process through the `IP_RECVOPTS` socket option, but this isn't implemented yet.

77-88 If the length of the first mbuf on the mbuf chain is less than 28 bytes (the size of the IP header plus the UDP header), `m_pullup` rearranges the mbuf chain so that at least 28 bytes are stored contiguously in the first mbuf.

```
udp_usrreq.c
55 void
56 udp_input(m, iphlen)
57 struct mbuf *m;
58 int iphlen;
59 {
60     struct ip *ip;
61     struct udphdr *uh;
62     struct inpcb *inp;
63     struct mbuf *opts = 0;
64     int len;
65     struct ip save_ip;
66     udpstat.udps_ipackets++;
67     /*
68      * Strip IP options, if any; should skip this,
69      * make available to user, and use on returned packets,
70      * but we don't yet have a way to check the checksum
71      * with options still present.
72      */
73     if (iphlen > sizeof(struct ip)) {
74         ip_stripoptions(m, (struct mbuf *) 0);
75         iphlen = sizeof(struct ip);
76     }
77     /*
78      * Get IP and UDP header together in first mbuf.
79      */
80     ip = mtod(m, struct ip *);
81     if (m->m_len < iphlen + sizeof(struct udphdr)) {
82         if ((m = m_pullup(m, iphlen + sizeof(struct udphdr))) == 0) {
83             udpstat.udps_hdrops++;
84             return;
85         }
86         ip = mtod(m, struct ip *);
87     }
88     uh = (struct udphdr *) ((caddr_t) ip + iphlen);
89     /*
90      * Make mbuf data length reflect UDP length.
91      * If not enough data to reflect UDP length, drop.
92      */
93     len = ntohs((u_short) uh->uh_ulen);
94     if (ip->ip_len != len) {
95         if (len > ip->ip_len) {
96             udpstat.udps_badlen++;
97             goto bad;
98         }
99         m_adj(m, len - ip->ip_len);
100        /* ip->ip_len = len; */
101    }
102    /*
103     * Save a copy of the IP header in case we want to restore
104     * it for sending an ICMP error message in response.
105     */
106    save_ip = *ip;
```

```

107  /*
108  * Checksum extended UDP header and data.
109  */
110  if (udpcksum && uh->uh_sum) {
111      ((struct ipovly *) ip)->ih_next = 0;
112      ((struct ipovly *) ip)->ih_prev = 0;
113      ((struct ipovly *) ip)->ih_x1 = 0;
114      ((struct ipovly *) ip)->ih_len = uh->uh_ulen;
115      if (uh->uh_sum = in_cksum(m, len + sizeof(struct ip))) {
116          udpstat.udps_badsum++;
117          m_freem(m);
118          return;
119      }
120  }

```

*udp\_usrreq.c*

Figure 23.21 udp\_input function: general validation of received UDP datagram.

### Verify UDP length

89-101 There are two lengths associated with a UDP datagram: the length field in the IP header (*ip\_len*) and the length field in the UDP header (*uh\_ulen*). Recall that *ipintr* subtracted the length of the IP header from *ip\_len* before calling *udp\_input* (Figure 10.11). The two lengths are compared and there are three possibilities:

1. *ip\_len* equals *uh\_ulen*. This is the common case.
2. *ip\_len* is greater than *uh\_ulen*. The IP datagram is too big, as shown in Figure 23.22.

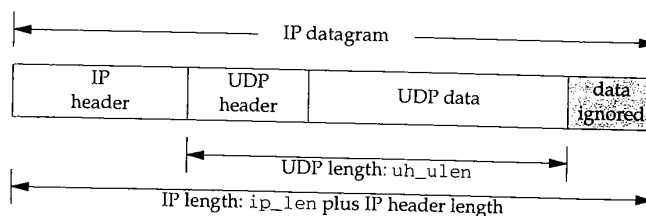

Figure 23.22 UDP length too small.

The code believes the smaller of the two lengths (the UDP header length) and *m\_adj* removes the excess bytes of data from the end of the datagram. In the code the second argument to *m\_adj* is negative, which we said in Figure 2.20 trims data from the end of the mbuf chain. It is possible in this scenario that the UDP length field has been corrupted. If so, the datagram will probably be discarded shortly, assuming the sender calculated the UDP checksum, that this checksum detects the error, and that the receiver verifies the checksum. The IP length field should be correct since it was verified by IP against the amount of data received from the interface, and the IP length field is covered by the mandatory IP header checksum.

3. `ip_len` is less than `uh_ulen`. The IP datagram is smaller than possible, given the length in the UDP header. Figure 23.23 shows this case.

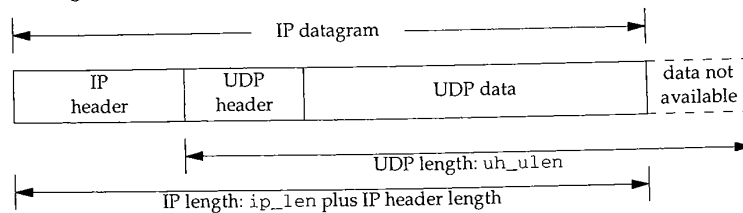

Figure 23.23 UDP length too big.

Something is wrong and the datagram is discarded. There is no other choice here: if the UDP length field has been corrupted, it can't be detected with the UDP checksum. The correct UDP length is needed to calculate the checksum.

As we've said, the UDP length is redundant. In Chapter 28 we'll see that TCP does not have a length field in its header—it uses the IP length field, minus the lengths of the IP and TCP headers, to determine the amount of data in the datagram. Why does the UDP length field exist? Possibly to add a small amount of error checking, since UDP checksums are optional.

#### Save copy of IP header and verify UDP checksum

102–106 `udp_input` saves a copy of the IP header before verifying the checksum, because the checksum computation wipes out some of the fields in the original IP header.

110 The checksum is verified only if UDP checksums are enabled for the kernel (`udpcksum`), and if the sender calculated a UDP checksum (the received checksum is nonzero).

This test is incorrect. If the sender calculated a checksum, it should be verified, regardless of whether outgoing checksums are calculated or not. The variable `udpcksum` should only specify whether outgoing checksums are calculated. Unfortunately many vendors have copied this incorrect test, although many vendors today finally ship their kernels with UDP checksums enabled by default.

111–120 Before calculating the checksum, the IP header is referenced as an `ipovly` structure (Figure 23.18) and the fields are initialized as described in the previous section when the UDP checksum is calculated by `udp_output`.

At this point special code is executed if the datagram is destined for a broadcast or multicast IP address. We defer this code until later in the section.

#### Demultiplexing Unicast Datagrams

Assuming the datagram is destined for a unicast address, Figure 23.24 shows the code that is executed.



given

```

                udp_usrreq.c
                /* demultiplex broadcast & multicast datagrams (Figure 23.26) */

206     /*
207     * Locate pcb for unicast datagram.
208     */
209     inp = udp_last_inpcb;
210     if (inp->inp_lport != uh->uh_dport ||
211         inp->inp_fport != uh->uh_sport ||
212         inp->inp_faddr.s_addr != ip->ip_src.s_addr ||
213         inp->inp_laddr.s_addr != ip->ip_dst.s_addr) {

214         inp = in_pcblookup(&udb, ip->ip_src, uh->uh_sport,
215                          ip->ip_dst, uh->uh_dport, INPLOOKUP_WILDCARD);
216         if (inp)
217             udp_last_inpcb = inp;
218         udpstat.udpps_pcbcachemiss++;
219     }
220     if (inp == 0) {
221         udpstat.udps_noport++;
222         if (m->m_flags & (M_BCAST | M_MCAST)) {
223             udpstat.udps_noportbcast++;
224             goto bad;
225         }
226         *ip = save_ip;
227         ip->ip_len += iphlen;
228         icmp_error(m, ICMP_UNREACH, ICMP_UNREACH_PORT, 0, 0);
229         return;
230     }
    
```

choice  
with the  
im.

t have a  
and TCP  
with field  
onal.

because

kernel  
sum is

ardless of  
ly spec-  
ied this  
cksums

ucture  
ien the

cast or

e code

Figure 23.24 udp\_input function: demultiplex unicast datagram.

**Check one-behind cache**

206-209 UDP maintains a pointer to the last Internet PCB for which it received a datagram, `udp_last_inpcb`. Before calling `in_pcblookup`, which might have to search many PCBs on the UDP list, the foreign and local addresses and ports of that last PCB are compared against the received datagram. This is called a *one-behind cache* [Partridge and Pink 1993], and it is based on the assumption that the next datagram received has a high probability of being destined for the same socket as the last received datagram [Mogul 1991]. This cache was introduced with the 4.3BSD Tahoe release.

210-213 The order of the four comparisons between the cached PCB and the received datagram is intentional. If the PCBs don't match, the comparisons should stop as soon as possible. The highest probability is that the destination port numbers are different—this is therefore the first test. The lowest probability of a mismatch is between the local addresses, especially on a host with just one interface, so this is the last test.

Unfortunately this one-behind cache, as coded, is practically useless [Partridge and Pink 1993]. The most common type of UDP server binds only its well-known port, leaving its local address, foreign address, and foreign port wildcarded. The most common type of UDP client does not connect its UDP socket; it specifies the destination address for each datagram using `sendto`. Therefore most of the time the three values in the PCB `inp_laddr`, `inp_faddr`, and `inp_fport` are wildcards. In the cache comparison the four values in the received datagram are never wildcards, meaning the cache entry will compare equal with the received datagram only when the PCB has all four local and foreign values specified to nonwildcard values. This happens only for a connected UDP socket.

On the system `bsdi`, the counter `udpps_pcbcachemiss` was 41,253 and the counter `udps_ipackets` was 42,485. This is less than a 3% cache hit rate.

The `netstat -s` command prints most of the fields in the `udpstat` structure (Figure 23.5). Unfortunately the Net/3 version, and most vendor's versions, never print `udpps_pcbcachemiss`. If you want to see the value, use a debugger to examine the variable in the running kernel.

#### Search all UDP PCBs

214-218 Assuming the comparison with the cached PCB fails, `in_pcblookup` searches for a match. The `INPLOOKUP_WILDCARD` flag is specified, allowing a wildcard match. If a match is found, the pointer to the PCB is saved in `udp_last_inpcb`, which we said is a cache of the last received UDP datagram's PCB.

#### Generate ICMP port unreachable error

220-230 If a matching PCB is not found, UDP normally generates an ICMP port unreachable error. First the `m_flags` for the received mbuf chain is checked to see if the datagram was sent to a link-level broadcast or multicast destination address. It is possible to receive an IP datagram with a unicast IP address that was sent to a broadcast or multicast link-level address, but an ICMP port unreachable error must not be generated. If it is OK to generate the ICMP error, the IP header is restored to its received value (`save_ip`) and the IP length is also set back to its original value.

This check for a link-level broadcast or multicast address is redundant. `icmp_error` also performs this check. The only advantage in this redundant check is to maintain the counter `udps_noportbcast` in addition to the counter `udps_noport`.

The addition of `iphlen` back into `ip_len` is a bug. `icmp_error` will also do this, causing the IP length field in the IP header returned in the ICMP error to be 20 bytes too large. You can tell if a system has this bug by adding a few lines of code to the Traceroute program (Chapter 8 of Volume 1) to print this field in the ICMP port unreachable that is returned when the destination host is finally reached.

Figure 23.25 is the next section of processing for a unicast datagram, delivering the datagram to the socket corresponding to the destination PCB.

```

231  /*-----udp_usrreq.c
232  * Construct sockaddr format source address.
233  * Stuff source address and datagram in user buffer.
234  */
235  udp_in.sin_port = uh->uh_sport;
236  udp_in.sin_addr = ip->ip_src;
237  if (inp->inp_flags & INP_CONTROLOPTS) {
238      struct mbuf **mp = &opts;
239      if (inp->inp_flags & INP_RECVDSTADDR) {
240          *mp = udp_saveopt((caddr_t) &ip->ip_dst,
241                          sizeof(struct in_addr), IP_RECVDSTADDR);
242          if (*mp)
243              mp = &(*mp)->m_next;
244      }
245  #ifndef notyet
246      /* IP options were tossed above */
247      if (inp->inp_flags & INP_RECVOPTS) {
248          *mp = udp_saveopt((caddr_t) opts_deleted_above,
249                          sizeof(struct in_addr), IP_RECVOPTS);
250          if (*mp)
251              mp = &(*mp)->m_next;
252      }
253      /* ip_srcroute doesn't do what we want here, need to fix */
254      if (inp->inp_flags & INP_RECVRETOPTS) {
255          *mp = udp_saveopt((caddr_t) ip_srcroute(),
256                          sizeof(struct in_addr), IP_RECVRETOPTS);
257          if (*mp)
258              mp = &(*mp)->m_next;
259      }
260  #endif
261  }
262  iphlen += sizeof(struct udphdr);
263  m->m_len -= iphlen;
264  m->m_pkthdr.len -= iphlen;
265  m->m_data += iphlen;
266  if (sbappendaddr(&inp->inp_socket->so_rcv, (struct sockaddr *) &udp_in,
267                  m, opts) == 0) {
268      udpstat.udps_fullsock++;
269      goto bad;
270  }
271  sorwakeup(inp->inp_socket);
272  return;
273  bad:
274  m_freem(m);
275  if (opts)
276      m_freem(opts);
277  }
-----udp_usrreq.c

```

Figure 23.25 udp\_input function: deliver unicast datagram to socket.

**Return source IP address and source port**

231-236 The source IP address and source port number from the received IP datagram are stored in the global `sockaddr_in` structure `udp_in`. This structure is passed as an argument to `sbappendaddr` later in the function.

Using a global to hold the IP address and port number is OK because `udp_input` is single threaded. When this function is called by `ipintr` it processes the received datagram completely before returning. Also, `sbappendaddr` copies the socket address structure from the global into an mbuf.

**IP\_RECVSTADDR socket option**

237-244 The constant `INP_CONTROLOPTS` is the combination of the three socket options that the process can set to cause control information to be returned through the `recvmsg` system call for a UDP socket (Figure 22.5). The `IP_RECVSTADDR` socket option returns the destination IP address from the received UDP datagram as control information. The function `udp_saveopt` allocates an mbuf of type `MT_CONTROL` and stores the 4-byte destination IP address in the mbuf. We show this function in Section 23.8.

This socket option appeared with 4.3BSD Reno and was intended for applications such as TFTP, the Trivial File Transfer Protocol, that should not respond to client requests that are sent to a broadcast address. Unfortunately, even if the receiving application uses this option, it is nontrivial to determine if the destination IP address is a broadcast address or not (Exercise 23.6).

When the multicasting changes were added in 4.4BSD, this code was left in only for datagrams destined for a unicast address. We'll see in Figure 23.26 that this option is not implemented for datagrams sent to a broadcast or multicast address. This defeats the purpose of the option!

**Unimplemented socket options**

245-260 This code is commented out because it doesn't work. The intent of the `IP_RECVOPTS` socket option is to return the IP options from the received datagram as control information, and the intent of `IP_RECVRETOPTS` socket option is to return source route information. The manipulation of the `mp` variable by all three `IP_RECV` socket options is to build a linked list of up to three mbufs that are then placed onto the socket's buffer by `sbappendaddr`. The code shown in Figure 23.25 only returns one option as control information, so the `m_next` pointer of that mbuf is always a null pointer.

**Append data to socket's receive queue**

262-272 At this point the received datagram (the mbuf chain pointed to by `m`), is ready to be placed onto the socket's receive queue along with a socket address structure representing the sender's IP address and port (`udp_in`), and optional control information (the destination IP address, the mbuf pointed to by `opts`). This is done by `sbappendaddr`. Before calling this function, however, the pointer and lengths of the first mbuf on the chain are adjusted to ignore the IP and UDP headers. Before returning, `sorwakeup` is called for the receiving socket to wake up any processes asleep on the socket's receive queue.

### Error return

273-276 If an error is encountered during UDP input processing, `udp_input` jumps to the label `bad`. The mbuf chain containing the datagram is released, along with the mbuf chain containing any control information (if present).

### Demultiplexing Multicast and Broadcast Datagrams

We now return to the portion of `udp_input` that handles datagrams sent to a broadcast or multicast IP address. The code is shown in Figure 23.26.

121-138 As the comments indicate, these datagrams are delivered to *all* sockets that match, not just a single socket. The inadequacy of the UDP interface that is mentioned refers to the inability of a process to receive asynchronous errors on a UDP socket (notably ICMP port unreachable) unless the socket is connected. We described this in Section 22.11.

139-145 The source IP address and port number are saved in the global `sockaddr_in` structure `udp_in`, which is passed to `sbappendaddr`. The mbuf chain's length and data pointer are updated to ignore the IP and UDP headers.

146-164 The large `for` loop scans each UDP PCB to find all matching PCBs. `in_pcblookup` is not called for this demultiplexing because it returns only one PCB, whereas the broadcast or multicast datagram may be delivered to more than one PCB.

If the local port in the PCB doesn't match the destination port from the received datagram, the entry is ignored. If the local address in the PCB is not the wildcard, it is compared to the destination IP address and the entry is skipped if they're not equal. If the foreign address in the PCB is not a wildcard, it is compared to the source IP address and if they match, the foreign port must also match the source port. This last test assumes that if the socket is connected to a foreign IP address it must also be connected to a foreign port, and vice versa. This is the same logic we saw in `in_pcblookup`.

165-177 If this is not the first match found (`last` is nonnull), a copy of the datagram is placed onto the receive queue for the previous match. Since `sbappendaddr` releases the mbuf chain when it is done, a copy is first made by `m_copy`. Any processes waiting for this data are awakened by `sorwakeup`. A pointer to this matching socket structure is saved in `last`.

This use of the variable `last` avoids calling `m_copy` (an expensive operation since an entire mbuf chain is copied) unless there are multiple recipients for a given datagram. In the common case of a single recipient, the `for` loop just sets `last` to the single matching PCB, and when the loop terminates, `sbappendaddr` places the mbuf chain onto the socket's receive queue—a copy is not made.

178-188 If this matching socket doesn't have either the `SO_REUSEPORT` or the `SO_REUSEADDR` socket option set, then there's no need to check for additional matches and the loop is terminated. The datagram is placed onto the single socket's receive queue in the call to `sbappendaddr` outside the loop.

189-197 If `last` is null at the end of the loop, no matches were found. An ICMP error is not generated because the datagram was sent to a broadcast or multicast IP address.

```

121     if (IN_MULTICAST(ntohl(ip->ip_dst.s_addr)) ||
122         in_broadcast(ip->ip_dst, m->m_pkthdr.rcvif)) {
123         struct socket *last;
124         /*
125          * Deliver a multicast or broadcast datagram to *all* sockets
126          * for which the local and remote addresses and ports match
127          * those of the incoming datagram. This allows more than
128          * one process to receive multi/broadcasts on the same port.
129          * (This really ought to be done for unicast datagrams as
130          * well, but that would cause problems with existing
131          * applications that open both address-specific sockets and
132          * a wildcard socket listening to the same port -- they would
133          * end up receiving duplicates of every unicast datagram.
134          * Those applications open the multiple sockets to overcome an
135          * inadequacy of the UDP socket interface, but for backwards
136          * compatibility we avoid the problem here rather than
137          * fixing the interface. Maybe 4.5BSD will remedy this?)
138          */
139
140         /*
141          * Construct sockaddr format source address.
142          */
143         udp_in.sin_port = uh->uh_sport;
144         udp_in.sin_addr = ip->ip_src;
145         m->m_len -= sizeof(struct udpiphdr);
146         m->m_data += sizeof(struct udpiphdr);
147         /*
148          * Locate pcb(s) for datagram.
149          * (Algorithm copied from raw_intr().)
150          */
151         last = NULL;
152         for (inp = udb.inp_next; inp != &udb; inp = inp->inp_next) {
153             if (inp->inp_lport != uh->uh_dport)
154                 continue;
155             if (inp->inp_laddr.s_addr != INADDR_ANY) {
156                 if (inp->inp_laddr.s_addr !=
157                     ip->ip_dst.s_addr)
158                     continue;
159             }
160             if (inp->inp_faddr.s_addr != INADDR_ANY) {
161                 if (inp->inp_faddr.s_addr !=
162                     ip->ip_src.s_addr ||
163                     inp->inp_fport != uh->uh_sport)
164                     continue;
165             }
166             if (last != NULL) {
167                 struct mbuf *n;
168
169                 if ((n = m_copy(m, 0, M_COPYALL)) != NULL) {
170                     if (sbappendaddr(&last->so_rcv,
171                                     (struct sockaddr *) &udp_in,
172                                     n, (struct mbuf *) 0) == 0) {
173                         m_freem(n);
174                         udpstat.udps_fullsock++;
175                     }
176                 }
177             }
178         }
179     }

```

udp\_usrreq.c

198-

Con

```

173         } else
174             sorwakeup(last);
175     }
176 }
177 last = inp->inp_socket;
178 /*
179  * Don't look for additional matches if this one does
180  * not have either the SO_REUSEPORT or SO_REUSEADDR
181  * socket options set. This heuristic avoids searching
182  * through all pcbs in the common case of a non-shared
183  * port. It assumes that an application will never
184  * clear these options after setting them.
185  */
186 if ((last->so_options & (SO_REUSEPORT | SO_REUSEADDR) == 0))
187     break;
188 }

189 if (last == NULL) {
190     /*
191     * No matching pcb found; discard datagram.
192     * (No need to send an ICMP Port Unreachable
193     * for a broadcast or multicast datgram.)
194     */
195     udpstat.udps_noportbcast++;
196     goto bad;
197 }
198 if (sbappendaddr(&last->so_rcv, (struct sockaddr *) &udp_in,
199                 m, (struct mbuf *) 0) == 0) {
200     udpstat.udps_fullsock++;
201     goto bad;
202 }
203 sorwakeup(last);
204 return;
205 }

```

*udp\_usrreq.c*

Figure 23.26 udp\_input function: demultiplexing of broadcast and multicast datagrams.

198-204 The final matching entry (which could be the only matching entry) has the original datagram (m) placed onto its receive queue. After sorwakeup is called, udp\_input returns, since the processing the broadcast or multicast datagram is complete.

The remainder of the function (shown previously in Figure 23.24) handles unicast datagrams.

### Connected UDP Sockets and Multihomed Hosts

There is a subtle problem when using a connected UDP socket to exchange datagrams with a process on a multihomed host. Datagrams from the peer may arrive with a different source IP address and will not be delivered to the connected socket.

Consider the example shown in Figure 23.27.

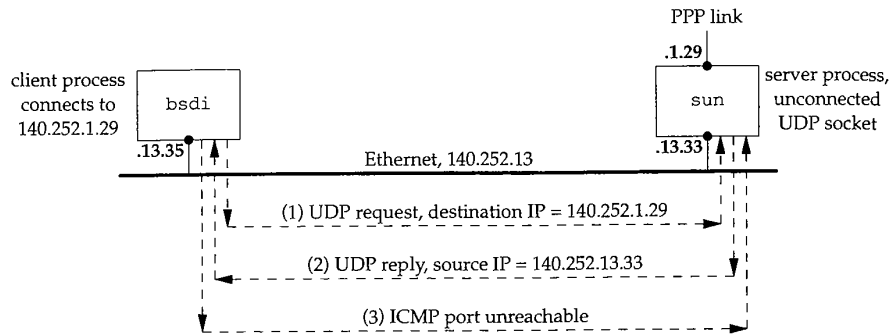

Figure 23.27 Example of connected UDP socket sending datagram to a multihomed host.

Three steps take place.

1. The client on `bsd1` creates a UDP socket and connects it to 140.252.1.29, the PPP interface on `sun`, not the Ethernet interface. A datagram is sent on the socket to the server.

The server on `sun` receives the datagram and accepts it, even though it arrives on an interface that differs from the destination IP address. (`sun` is acting as a router, so whether it implements the weak end system model or the strong end system model doesn't matter.) The datagram is delivered to the server, which is waiting for client requests on an unconnected UDP socket.

2. The server sends a reply, but since the reply is being sent on an unconnected UDP socket, the source IP address for the reply is chosen by the kernel based on the outgoing interface (140.252.13.33). The destination IP address in the request is not used as the source address for the reply.

When the reply is received by `bsd1` it is not delivered to the client's connected UDP socket since the IP addresses don't match.

3. `bsd1` generates an ICMP port unreachable error since the reply can't be demultiplexed. (This assumes that there is not another process on `bsd1` eligible to receive the datagram.)

The problem in this example is that the server does not use the destination IP address from the request as the source IP address of the reply. If it did, the problem wouldn't exist, but this solution is nontrivial—see Exercise 23.10. We'll see in Figure 28.16 that a TCP server uses the destination IP address from the client as the source IP address from the server, if the server has not explicitly bound a local IP address to its socket.



## 23.8 udp\_saveopt Function

If a process specifies the IP\_RECVDSTADDR socket option, to receive the destination IP address from the received datagram `udp_saveopt` is called by `udp_input`:

```
*mp = udp_saveopt((caddr_t) &ip->ip_dst, sizeof(struct in_addr),
                 IP_RECVDSTADDR);
```

Figure 23.28 shows this function.

```

278 /*
279  * Create a "control" mbuf containing the specified data
280  * with the specified type for presentation with a datagram.
281  */
282 struct mbuf *
283 udp_saveopt(p, size, type)
284 caddr_t p;
285 int     size;
286 int     type;
287 {
288     struct cmsghdr *cp;
289     struct mbuf *m;

290     if ((m = m_get(M_DONTWAIT, MT_CONTROL)) == NULL)
291         return ((struct mbuf *) NULL);
292     cp = (struct cmsghdr *) mtod(m, struct cmsghdr *);
293     bcopy(p, CMSG_DATA(cp), size);
294     size += sizeof(*cp);
295     m->m_len = size;
296     cp->cmsg_len = size;
297     cp->cmsg_level = IPPROTO_IP;
298     cp->cmsg_type = type;
299     return (m);
300 }

```

*udp\_usrreq.c*

*udp\_usrreq.c*

Figure 23.28 `udp_saveopt` function: create mbuf with control information.

278-289 The arguments are `p`, a pointer to the information to be stored in the mbuf (the destination IP address from the received datagram); `size`, its size in bytes (4 in this example, the size of an IP address); and `type`, the type of control information (IP\_RECVDSTADDR).

290-299 An mbuf is allocated, and since the code is executing at the software interrupt layer, `M_DONTWAIT` is specified. The pointer `cp` points to the data portion of the mbuf, and it is cast into a pointer to a `cmsghdr` structure (Figure 16.14). The IP address is copied from the IP header into the data portion of the `cmsghdr` structure by `bcopy`. The length of the mbuf is then set (to 16 in this example), followed by the remainder of the `cmsghdr` structure. Figure 23.29 shows the final state of the mbuf.

The `cmsg_len` field contains the length of the `cmsghdr` structure (12) plus the size of the `cmsg_data` field (4 for this example). If the application calls `recvmsg` to receive the control information, it must go through the `cmsghdr` structure to determine the type and length of the `cmsg_data` field.

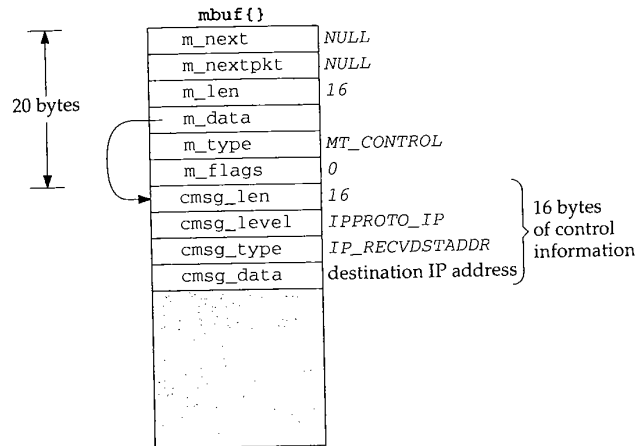

Figure 23.29 Mbuf containing destination address from received datagram as control information.

### 23.9 udp\_ctlinput Function

When `icmp_input` receives an ICMP error (destination unreachable, parameter problem, redirect, source quench, and time exceeded) the corresponding protocol's `pr_ctlinput` function is called:

```
if (ctlfunc = inetsw[ ip_protox[icp->icmp_ip.ip_p] ].pr_ctlinput)
    (*ctlfunc)(code, (struct sockaddr *)&icm_src, &icp->icmp_ip);
```

For UDP, Figure 22.32 showed that the function `udp_ctlinput` is called. We show this function in Figure 23.30.

314-322 The arguments are `cmd`, one of the `PRC_XXX` constants from Figure 11.19; `sa`, a pointer to a `sockaddr_in` structure containing the source IP address from the ICMP message; and `ip`, a pointer to the IP header that caused the error. For the destination unreachable, parameter problem, source quench, and time exceeded errors, the pointer `ip` points to the IP header that caused the error. But when `udp_ctlinput` is called by `pfctlinput` for redirects (Figure 22.32), `sa` points to a `sockaddr_in` structure containing the destination address that should be redirected, and `ip` is a null pointer. There is no loss of information in this final case, since we saw in Section 22.11 that a redirect is applied to all TCP and UDP sockets connected to the destination address. The nonnull third argument is needed, however, for other errors, such as a port unreachable, since the protocol header following the IP header contains the unreachable port.

323-325 If the error is not a redirect, and either the `PRC_XXX` value is too large or there is no error code in the global array `inetctlerrmap`, the ICMP error is ignored. To understand this test we need to review what happens to a received ICMP message.

1. `icmp_input` converts the ICMP type and code into a `PRC_XXX` error code.
2. The `PRC_XXX` error code is passed to the protocol's control-input function.

```

314 void
315 udp_ctlinput(cmd, sa, ip)
316 int cmd;
317 struct sockaddr *sa;
318 struct ip *ip;
319 {
320     struct udphdr *uh;
321     extern struct in_addr zero_in_addr;
322     extern u_char inetctlerrmap[];

323     if (!PRC_IS_REDIRECT(cmd) &&
324         ((unsigned) cmd >= PRC_NCMDS || inetctlerrmap[cmd] == 0))
325         return;
326     if (ip) {
327         uh = (struct udphdr *) ((caddr_t) ip + (ip->ip_hl << 2));
328         in_pcbnotify(&udb, sa, uh->uh_dport, ip->ip_src, uh->uh_sport,
329                     cmd, udp_notify);
330     } else
331         in_pcbnotify(&udb, sa, 0, zero_in_addr, 0, cmd, udp_notify);
332 }

```

*udp\_usrreq.c*

*udp\_usrreq.c*

Figure 23.30 udp\_ctlinput function: process received ICMP errors.

3. The Internet protocols (TCP and UDP) map the PRC\_XXX error code into one of the Unix errno values using inetctlerrmap, and this value is returned to the process.

Figures 11.1 and 11.2 summarize this processing of ICMP messages.

Returning to Figure 23.30, we can see what happens to an ICMP source quench that arrives in response to a UDP datagram. `icmp_input` converts the ICMP message into the error `PRC_QUENCH` and `udp_ctlinput` is called. But since the `errno` column for this ICMP error is blank in Figure 11.2, the error is ignored.

326-331 The function `in_pcbnotify` notifies the appropriate PCBs of the ICMP error. If the third argument to `udp_ctlinput` is nonnull, the source and destination UDP ports from the datagram that caused the error are passed to `in_pcbnotify` along with the source IP address.

#### udp\_notify Function

The final argument to `in_pcbnotify` is a pointer to a function that `in_pcbnotify` calls for each PCB that is to receive the error. The function for UDP is `udp_notify` and we show it in Figure 23.31.

301-313 The `errno` value, the second argument to this function, is stored in the socket's `so_error` variable. By setting this socket variable, the socket becomes readable and writable if the process calls `select`. Any processes waiting to receive or send on the socket are then awakened to receive the error.

```

305 static void
306 udp_notify(inp, errno)
307 struct inpcb *inp;
308 int      errno;
309 {
310     inp->inp_socket->so_error = errno;
311     sorwakeup(inp->inp_socket);
312     sowwakeup(inp->inp_socket);
313 }

```

Figure 23.31 udp\_notify function: notify process of an asynchronous error.

### 23.10 udp\_usrreq Function

The protocol's user-request function is called for a variety of operations. We saw in Figure 23.14 that a call to any one of the five write functions on a UDP socket ends up calling UDP's user-request function with a request of PRU\_SEND.

Figure 23.32 shows the beginning and end of `udp_usrreq`. The body of the switch is discussed in separate figures following this figure. The function arguments are described in Figure 15.17.

```

417 int
418 udp_usrreq(so, req, m, addr, control)
419 struct socket *so;
420 int      req;
421 struct mbuf *m, *addr, *control;
422 {
423     struct inpcb *inp = sotoinpcb(so);
424     int      error = 0;
425     int      s;
426
427     if (req == PRU_CONTROL)
428         return (in_control(so, (int) m, (caddr_t) addr,
429                             (struct ifnet *) control));
430     if (inp == NULL && req != PRU_ATTACH) {
431         error = EINVAL;
432         goto release;
433     }
434     /*
435      * Note: need to block udp_input while changing
436      * the udp pcb queue and/or pcb addresses.
437      */
438     switch (req) {

```

```

/* switch cases */

```

```

522     default:
523         panic("udp_usrreq");
524     }

525     release:
526     if (control) {
527         printf("udp control data unexpectedly retained\n");
528         m_freem(control);
529     }
530     if (m)
531         m_freem(m);
532     return (error);
533 }

```

*udp\_usrreq.c*

Figure 23.32 Body of `udp_usrreq` function.

- 417-428 The `PRU_CONTROL` request is from the `ioctl` system call. The function `in_control` processes the request completely.
- 429-432 The socket pointer was converted to the PCB pointer when `inp` was declared at the beginning of the function. The only time a null PCB pointer is allowed is when a new socket is being created (`PRU_ATTACH`).
- 433-436 The comment indicates that whenever entries are being added to or deleted from UDP's PCB list, the code must be protected by `splnet`. This is done because `udp_usrreq` is called as part of a system call, and it doesn't want to be interrupted by UDP input (called by IP input, which is called as a software interrupt) while it is modifying the doubly linked list of PCBs. UDP input is also blocked while modifying the local or foreign addresses or ports in a PCB, to prevent a received UDP datagram from being delivered incorrectly by `in_pcblookup`.

We now discuss the individual case statements. The `PRU_ATTACH` request, shown in Figure 23.33, is from the `socket` system call.

- 438-447 If the socket structure already points to a PCB, `EINVAL` is returned. `in_pcballoc` allocates a new PCB, adds it to the front of UDP's PCB list, and links the socket structure and the PCB to each other.
- 448-450 `sorereserve` reserves buffer space for a receive buffer and a send buffer for the socket. As noted in Figure 16.7, `sorereserve` just enforces system limits; the buffer space is not actually allocated. The default values for the send and receive buffer sizes are 9216 bytes (`udp_sendspace`) and 41,600 bytes (`udp_recvspace`). The former allows for a maximum UDP datagram size of 9200 bytes (to hold 8 Kbytes of data in an NFS packet), plus the 16-byte `sockaddr_in` structure for the destination address. The latter allows for 40 1024-byte datagrams to be queued at one time for the socket. The process can change these defaults by calling `setsockopt`.
- 451-452 There are two fields in the prototype IP header in the PCB that the process can change by calling `setsockopt`: the TTL and the TOS. The TTL defaults to 64 (`ip_defttl`) and the TOS defaults to 0 (normal service), since the PCB is initialized to 0 by `in_pcballoc`.

```

438     case PRU_ATTACH:
439         if (inp != NULL) {
440             error = EINVAL;
441             break;
442         }
443         s = splnet();
444         error = in_pcballoc(so, &udb);
445         splx(s);
446         if (error)
447             break;
448         error = soreserve(so, udp_sendspace, udp_recvspace);
449         if (error)
450             break;
451         ((struct inpcb *) so->so_pcb)->inp_ip.ip_ttl = ip_defttl;
452         break;
453     case PRU_DETACH:
454         udp_detach(inp);
455         break;

```

Figure 23.33 `udp_usrreq` function: PRU\_ATTACH and PRU\_DETACH requests.

453-455 The close system call issues the PRU\_DETACH request. The function `udp_detach`, shown in Figure 23.34, is called. This function is also called later in this section for the PRU\_ABORT request.

```

534 static void
535 udp_detach(inp)
536 struct inpcb *inp;
537 {
538     int    s = splnet();
539     if (inp == udp_last_inpcb)
540         udp_last_inpcb = &udb;
541     in_pcbdetach(inp);
542     splx(s);
543 }

```

Figure 23.34 `udp_detach` function: delete a UDP PCB.

If the last-received PCB pointer (the one-behind cache) points to the PCB being detached, the cache pointer is set to the head of the UDP list (`udb`). The function `in_pcbdetach` removes the PCB from UDP's list and releases the PCB.

Returning to `udp_usrreq`, a PRU\_BIND request is the result of the bind system call and a PRU\_LISTEN request is the result of the listen system call. Both are shown in Figure 23.35.

456-460 All the work for a PRU\_BIND request is done by `in_pcbbind`.

461-463 The PRU\_LISTEN request is invalid for a connectionless protocol—it is used only by connection-oriented protocols.

eq.c

```

456     case PRU_BIND:
457         s = splnet();
458         error = in_pcbbind(inp, addr);
459         splx(s);
460         break;

461     case PRU_LISTEN:
462         error = EOPNOTSUPP;
463         break;

```

Figure 23.35 udp\_usrreq function: PRU\_BIND and PRU\_LISTEN requests.

We mentioned earlier that a UDP application, either a client or server (normally a client), can call `connect`. This fixes the foreign IP address and port number that this socket can send to or receive from. Figure 23.36 shows the PRU\_CONNECT, PRU\_CONNECT2, and PRU\_ACCEPT requests.

eq.c

```

464     case PRU_CONNECT:
465         if (inp->inp_faddr.s_addr != INADDR_ANY) {
466             error = EISCONN;
467             break;
468         }
469         s = splnet();
470         error = in_pcbconnect(inp, addr);
471         splx(s);
472         if (error == 0)
473             soisconnected(so);
474         break;

475     case PRU_CONNECT2:
476         error = EOPNOTSUPP;
477         break;

478     case PRU_ACCEPT:
479         error = EOPNOTSUPP;
480         break;

```

Figure 23.36 udp\_usrreq function: PRU\_CONNECT, PRU\_CONNECT2, and PRU\_ACCEPT requests.

464-474 If the socket is already connected, EISCONN is returned. The socket should never be connected at this point, because a call to `connect` on an already-connected UDP socket generates a PRU\_DISCONNECT request before this PRU\_CONNECT request. Otherwise `in_pcbconnect` does all the work. If no errors are encountered, `soisconnected` marks the socket structure as being connected.

475-477 The `socketpair` system call issues the PRU\_CONNECT2 request, which is defined only for the Unix domain protocols.

478-480 The PRU\_ACCEPT request is from the `accept` system call, which is defined only for connection-oriented protocols.

The PRU\_DISCONNECT request can occur in two cases for a UDP socket:

1. When a connected UDP socket is closed, PRU\_DISCONNECT is called before PRU\_DETACH.
2. When a connect is issued on an already-connected UDP socket, soconnect issues the PRU\_DISCONNECT request before the PRU\_CONNECT request.

Figure 23.37 shows the PRU\_DISCONNECT request.

```

481     case PRU_DISCONNECT:
482         if (inp->inp_faddr.s_addr == INADDR_ANY) {
483             error = ENOTCONN;
484             break;
485         }
486         s = splnet();
487         in_pcbdisconnect(inp);
488         inp->inp_laddr.s_addr = INADDR_ANY;
489         splx(s);
490         so->so_state &= ~SS_ISCONNECTED;    /* XXX */
491         break;

```

udp\_usrreq.c

Figure 23.37 udp\_usrreq function: PRU\_DISCONNECT request.

If the socket is not already connected, ENOTCONN is returned. Otherwise in\_pcbdisconnect sets the foreign IP address to 0.0.0.0 and the foreign port to 0. The local address is also set to 0.0.0.0, since this PCB variable could have been set by connect.

A call to shutdown specifying that the process has finished sending data generates the PRU\_SHUTDOWN request, although it is rare for a process to issue this system call for a UDP socket. Figure 23.38 shows the PRU\_SHUTDOWN, PRU\_SEND, and PRU\_ABORT requests.

```

492     case PRU_SHUTDOWN:
493         socantsendmore(so);
494         break;
495     case PRU_SEND:
496         return (udp_output(inp, m, addr, control));
497     case PRU_ABORT:
498         soisdisconnected(so);
499         udp_detach(inp);
500         break;

```

udp\_usrreq.c

Figure 23.38 udp\_usrreq function: PRU\_SHUTDOWN, PRU\_SEND, and PRU\_ABORT requests.

492-494 socantsendmore sets the socket's flags to prevent any future output.



495-496 In Figure 23.14 we showed how the five write functions ended up calling `udp_usrreq` with a `PRU_SEND` request. `udp_output` sends the datagram. `udp_usrreq` returns, to avoid falling through to the label `release` (Figure 23.32), since the mbuf chain containing the data (`m`) must not be released yet. IP output appends this mbuf chain to the appropriate interface output queue, and the device driver will release the mbuf when the data has been transmitted.

The only buffering of UDP output within the kernel is on the interface's output queue. If there is room in the socket's send buffer for the datagram and destination address, `send` calls `udp_usrreq`, which we see calls `udp_output`. We saw in Figure 23.20 that `ip_output` is then called, which calls `ether_output` for an Ethernet, placing the datagram onto the interface's output queue (if there is room). If the process calls `sendto` faster than the interface can transmit the datagrams, `ether_output` can return `ENOBUFS`, which is returned to the process.

497-500 A `PRU_ABORT` request should never be generated for a UDP socket, but if it is, the socket is disconnected and the PCB detached.

The `PRU_SOCKADDR` and `PRU_PEERADDR` requests are from the `getsockname` and `getpeername` system calls, respectively. These two requests, and the `PRU_SENSE` request, are shown in Figure 23.39.

```

-----udp_usrreq.c
501     case PRU_SOCKADDR:
502         in_setsockaddr(inp, addr);
503         break;

504     case PRU_PEERADDR:
505         in_setpeeraddr(inp, addr);
506         break;

507     case PRU_SENSE:
508         /*
509          * fstat: don't bother with a blocksize.
510          */
511         return (0);
-----udp_usrreq.c

```

Figure 23.39 `udp_usrreq` function: `PRU_SOCKADDR`, `PRU_PEERADDR`, and `PRU_SENSE` requests.

501-506 The functions `in_setsockaddr` and `in_setpeeraddr` fetch the information from the PCB, storing the result in the `addr` argument.

507-511 The `fstat` system call generates the `PRU_SENSE` request. The function returns `OK`, but doesn't return any other information. We'll see later that TCP returns the size of the send buffer as the `st_blksize` element of the `stat` structure.

The remaining seven `PRU_xxx` requests, shown in Figure 23.40, are not supported for a UDP socket.

## 23.12

## UDP PC

```

512     case PRU_SENDOOB:
513     case PRU_FASTTIMO:
514     case PRU_SLOWTIMO:
515     case PRU_PROTORCV:
516     case PRU_PROTOSEND:
517         error = EOPNOTSUPP;
518         break;
519     case PRU_RCVD:
520     case PRU_RCVOOB:
521         return (EOPNOTSUPP); /* do not free mbuf's */

```

Figure 23.40 udp\_usrreq function: unsupported requests.

There is a slight difference in how the last two are handled because PRU\_RCVD doesn't pass a pointer to an mbuf as an argument (*m* is a null pointer) and PRU\_RCVOOB passes a pointer to an mbuf for the protocol to fill in. In both cases the error is immediately returned, without breaking out of the *switch* and releasing the mbuf chain. With PRU\_RCVOOB the caller releases the mbuf that it allocated.

### 23.11 udp\_sysctl Function

The *sysctl* function for UDP supports only a single option, the UDP checksum flag. The system administrator can enable or disable UDP checksums using the *sysctl(8)* program. Figure 23.41 shows the *udp\_sysctl* function. This function calls *sysctl\_int* to fetch or set the value of the integer *udpcksum*.

```

547 udp_sysctl(name, namelen, oldp, oldlenp, newp, newlen)
548 int     *name;
549 u_int   namelen;
550 void    *oldp;
551 size_t  *oldlenp;
552 void    *newp;
553 size_t  newlen;
554 {
555     /* All sysctl names at this level are terminal. */
556     if (namelen != 1)
557         return (ENOTDIR);
558     switch (name[0]) {
559     case UDPCTL_CHECKSUM:
560         return (sysctl_int(oldp, oldlenp, newp, newlen, &udpcksum));
561     default:
562         return (ENOPROTOPT);
563     }
564     /* NOTREACHED */
565 }

```

Figure 23.41 udp\_sysctl function.

## 23.12 Implementation Refinements

### UDP PCB Cache

In Section 22.12 we talked about some general features of PCB searching and how the code we've seen uses a linear search of the protocol's PCB list. We now tie this together with the one-behind cache used by UDP in Figure 23.24.

The problem with the one-behind cache occurs when the cached PCB contains wildcard values (for either the local address, foreign address, or foreign port): the cached value never matches any received datagram. One solution tested in [Partridge and Pink 1993] is to modify the cache to not compare wildcarded values. That is, instead of comparing the foreign address in the PCB with the source address in the datagram, compare these two values only if the foreign address in the PCB is not a wildcard.

There's a subtle problem with this approach [Partridge and Pink 1993]. Assume there are two sockets bound to local port 555. One has the remaining three elements wildcarded, while the other has connected to the foreign address 128.1.2.3 and the foreign port 1600. If we cache the first PCB and a datagram arrives from 128.1.2.3, port 1600, we can't ignore comparing the foreign addresses just because the cached value has a wildcarded foreign address. This is called *cache hiding*. The cached PCB has hidden another PCB that is a better match in this example.

To get around cache hiding requires more work when a new entry is added to or deleted from the cache. Those PCBs that hide other PCBs cannot be cached. This is not a problem, however, because the normal scenario is to have one socket per local port. The example we just gave with two sockets bound to local port 555, while possible (especially on a multihomed host), is rare.

The next enhancement tested in [Partridge and Pink 1993] is to also remember the PCB of the last datagram sent. This is motivated by [Mogul 1991], who shows that half of all datagrams received are replies to the last datagram that was sent. Cache hiding is a problem here also, so PCBs that would hide other PCBs are not cached.

The results of these two caches shown in [Partridge and Pink 1993] on a general-purpose system measured for around 100,000 received UDP datagrams show a 57% hit rate for the last-received PCB cache and a 30% hit rate for the last-sent PCB cache. The amount of CPU time spent in `udp_input` is more than halved, compared to the version with no caching.

These two caches still depend on a certain amount of locality: that with a high probability the UDP datagram that just arrived is either from the same peer as the last UDP datagram received or from the peer to whom the last datagram was sent. The latter is typical for request-response applications that send a datagram and wait for a reply. [McKenney and Dove 1992] show that some applications, such as data entry into an on-line transaction processing (OLTP) system, don't yield the high cache hit rates that [Partridge and Pink 1993] observed. As we mentioned in Section 22.12, placing the PCBs onto hash chains provided an order of magnitude improvement over the last-received and last-sent caches for a system with thousands of OLTP connections.

## UDP Checksum

The next area for improving the implementation is to combine the copying of data between the process and the kernel with the calculation of the checksum. In Net/3, each byte of data is processed twice during an output operation: once when copied from the process into an mbuf (the function `uiomove`, which is called by `sosend`), and again when the UDP checksum is calculated (by the function `in_cksum`, which is called by `udp_output`). This happens on input as well as output.

[Partridge and Pink 1993] modified the UDP output processing from what we showed in Figure 23.14 so that a UDP-specific function named `udp_sosend` is called instead of `sosend`. This new function calculates the checksum of the UDP header and the pseudo-header in-line (instead of calling the general-purpose function `in_cksum`) and then copies the data from the process into an mbuf chain using a special function named `in_uiomove` (instead of the general-purpose `uiomove`). This new function copies the data *and* updates the checksum. The amount of time spent copying the data and calculating the checksum is reduced with this technique by about 40 to 45%.

On the receive side the scenario is different. UDP calculates the checksum of the UDP header and the pseudo-header, removes the UDP header, and queues the data for the appropriate socket. When the application reads the data, a special version of `soreceive` (called `udp_soreceive`) completes the calculation of the checksum while copying the data into the user's buffer. If the checksum is in error, however, the error is not detected until the entire datagram has been copied into the user's buffer. In the normal case of a blocking socket, `udp_soreceive` just waits for the next datagram to arrive. But if the socket is nonblocking, the error `EWOULDBLOCK` must be returned if another datagram is not ready to be passed to the process. This implies two changes in the socket interface for a nonblocking read from a UDP socket:

1. The `select` function can indicate that a nonblocking UDP socket is readable, yet the error `EWOULDBLOCK` is unexpectedly returned by one of the read functions if the checksum fails.
2. Since a checksum error is detected after the datagram has been copied into the user's buffer, the application's buffer is changed even though no data is returned by the read.

Even with a blocking socket, if the datagram with the checksum error contains 100 bytes of data and the next datagram without an error contains 40 bytes of data, `recvfrom` returns a length of 40, but the 60 bytes that follow in the user's buffer have also been modified.

[Partridge and Pink 1993] compare the timings for a copy versus a copy-with-checksum for six different computers. They show that the checksum is calculated for free during the copy operation on many architectures. This occurs when memory access speeds and CPU processing speeds are mismatched, as is true for many current RISC processors.

### 23.13 Summary

UDP is a simple, connectionless protocol, which is why we cover it before looking at TCP. UDP output is simple: IP and UDP headers are prepended to the user's data, as much of the header is filled in as possible, and the result is passed to `ip_output`. The only complication is calculating the UDP checksum, which involves prepending a pseudo-header just for the checksum computation. We'll encounter a similar pseudo-header for the calculation of the TCP checksum in Chapter 26.

When `udp_input` receives a datagram, it first performs a general validation (the length and checksum); the processing then differs depending on whether the destination IP address is a unicast address or a broadcast or multicast address. A unicast datagram is delivered to at most one process, but a broadcast or multicast datagram can be delivered to multiple processes. A one-behind cache is maintained for unicast datagrams, which maintains a pointer to the last Internet PCB for which a UDP datagram was received. We saw, however, that because of the prevalence of wildcard addressing with UDP applications, this cache is practically useless.

The `udp_ctlinput` function is called to handle received ICMP messages, and the `udp_usrreq` function handles the `PRU_xxx` requests from the socket layer.

### Exercises

- 23.1 List the five types of mbuf chains that `udp_output` passes to `ip_output`. (*Hint*: look at `sosend`.)
- 23.2 What happens to the answer for the previous exercise when the process specifies IP options for the outgoing datagram?
- 23.3 Does a UDP client need to call `bind`? Why or why not?
- 23.4 What happens to the processor priority level in `udp_output` if the socket is unconnected and the call to `M_PREPEND` in Figure 23.15 fails?
- 23.5 `udp_output` does not check for a destination port of 0. Is it possible to send a UDP datagram with a destination port of 0?
- 23.6 Assuming the `IP_RECVDSTADDR` socket option worked when a datagram was sent to a broadcast address, how can you then determine if this address is a broadcast address?
- 23.7 Who releases the mbuf that `udp_saveopt` (Figure 23.28) allocates?
- 23.8 How can a process disconnect a connected UDP socket? That is, the process calls `connect` and exchanges datagrams with that peer, and then the process wants to disconnect the socket, allowing it to call `sendto` and send a datagram to some other host.
- 23.9 In our discussion of Figure 22.25 we noted that a UDP application that calls `connect` with a foreign IP address of 255.255.255.255 actually sends datagrams out the primary interface with a destination IP address corresponding to the broadcast address of that interface. What happens if a UDP application uses an unconnected socket instead, calling `sendto` with a destination address of 255.255.255.255?

- 23.10 After discussing the problem with Figure 23.27, we mentioned that this problem would not exist if the server used the destination IP address from the request as the source IP address of the reply. Explain how the server could do this.
- 23.11 Implement changes to allow a process to perform path MTU discovery using UDP: the process must be able to set the "don't fragment" bit in the resulting IP datagram and be told if the corresponding ICMP destination unreachable error is received.
- 23.12 Does the variable `udp_in` need to be global?
- 23.13 Modify `udp_input` to save the IP options and make them available to the receiver with the `IP_RECVOPTS` socket option.
- 23.14 Fix the one-behind cache in Figure 23.24.
- 23.15 Fix `udp_input` to implement the `IP_RECVOPTS` and `IP_RETOPTS` socket options.
- 23.16 Fix `udp_input` so that the `IP_RECVDSTADDR` socket option works for datagrams sent to a broadcast or multicast address.

24.

24.