

United States Patent [19]

[11] **Patent Number:** **5,467,087**

Chu

[45] **Date of Patent:** **Nov. 14, 1995**

- [54] **HIGH SPEED LOSSLESS DATA COMPRESSION SYSTEM**
- [75] Inventor: **Ke-Chiang Chu**, Saratoga, Calif.
- [73] Assignee: **Apple Computer, Inc.**, Cupertino, Calif.
- [21] Appl. No.: **992,972**
- [22] Filed: **Dec. 18, 1992**
- [51] **Int. Cl.⁶** **H03M 7/30**
- [52] **U.S. Cl.** **341/51; 341/86**
- [58] **Field of Search** **341/51, 65, 67, 341/87, 95, 106, 107**

5, Sep. 1978, pp. 530–536, J. Ziv, A. Lempel, "Compression of Individual Sequences via Variable-Rate Coding". IEEE Transactions on Information Theory vol. II, 21, No. 2, Mar. 1975, pp. 194–203. Peter Elias, "Universal Codeword Sets and Representations of the Integers". Communications of the ACM, Apr. 1989 Vol. 32 No. 4, pp. 490–504, Edward R. Riala and Daniel H. Greene, "Data Compression with Finite Windows". Timothy C. Bell, John G. Cleary, Ian H. Witten, *Text Compression*, Prentice Hall, Englewood Cliffs, New Jersey, 1990, pp. 206–243. System Enhancement Associates, *ARC File Archive Utility Version 5.1*, copyright 1985, 1986, p. 2.

Primary Examiner—Howard L. Williams
Attorney, Agent, or Firm—Irene Y. Hu

[56] **References Cited**

U.S. PATENT DOCUMENTS

3,394,352	7/1968	Wernikoff	341/51
4,558,302	12/1985	Welch	340/347
5,010,345	4/1991	Nagy	341/65
5,045,852	9/1991	Mitchell et al.	341/51
5,184,126	2/1993	Nagy	341/67
5,220,417	6/1993	Sugiura	358/515
5,247,638	9/1993	O'Brien	341/87

FOREIGN PATENT DOCUMENTS

2-262766	10/1990	Japan	H04N 1/41
----------	---------	-------	-----------

OTHER PUBLICATIONS

IEEE, Computer, Jun. 1984, pp. 8–19, Terry A. Welch, Sperry Research Center, "A Technique for High-Performance Data Compression".
 IEEE, Transactions On Information Theory, vol. II 23, No. 3, May 1977, pp. 337–343 J. Ziv, A. Lempel, "A Universal Algorithm for Sequential Data Compression".
 IEEE, Transactions On Information Theory, vol. II 24, No.

[57] **ABSTRACT**

A data compression process and system that identifies the data type of an input data stream and then selects in response to the identified data type at least one data compression method from a set of data compression methods that provides an optimal compression ratio for that particular data type, thus maximizing the compression ratio for that input data stream. Moreover, the data compression process also provides means to alter the rate of compression during data compression for added flexibility and data compression efficiency. Furthermore, a system memory allocation process is also provided to allow system or user control over the amount of system memory to be allocated for the memory intensive data compression process. System memory allocation process estimates the memory requirement to compress the input data stream, and allocates only that amount of system memory as needed by the data compression for memory allocation efficiency.

34 Claims, 8 Drawing Sheets

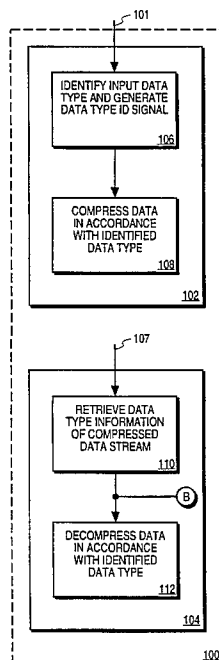

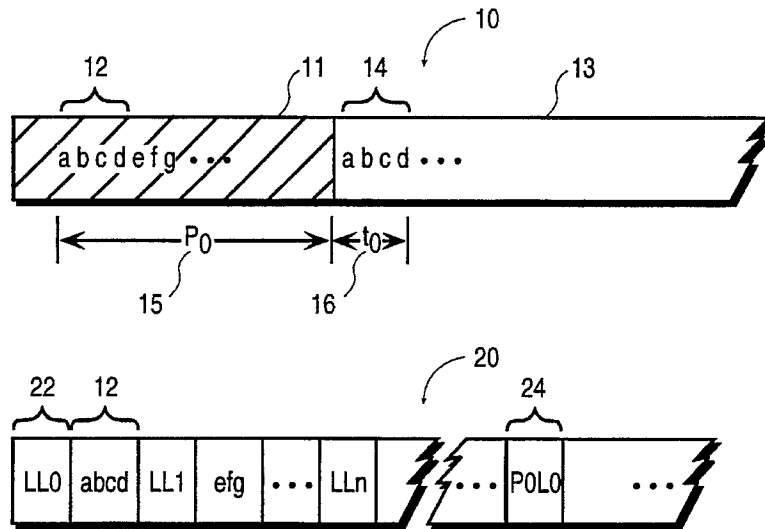

FIG. 1 (PRIOR ART)

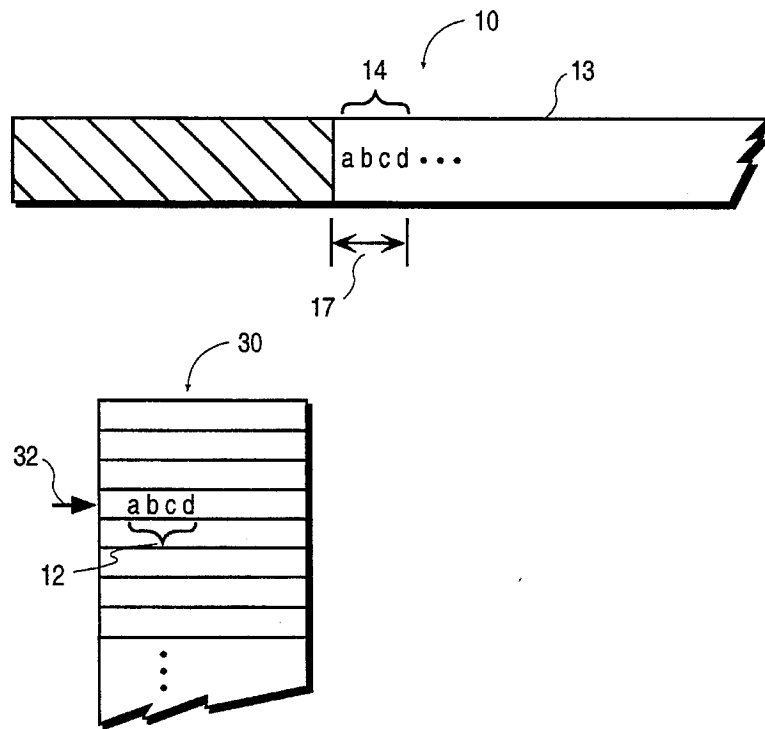

FIG. 2 (PRIOR ART)

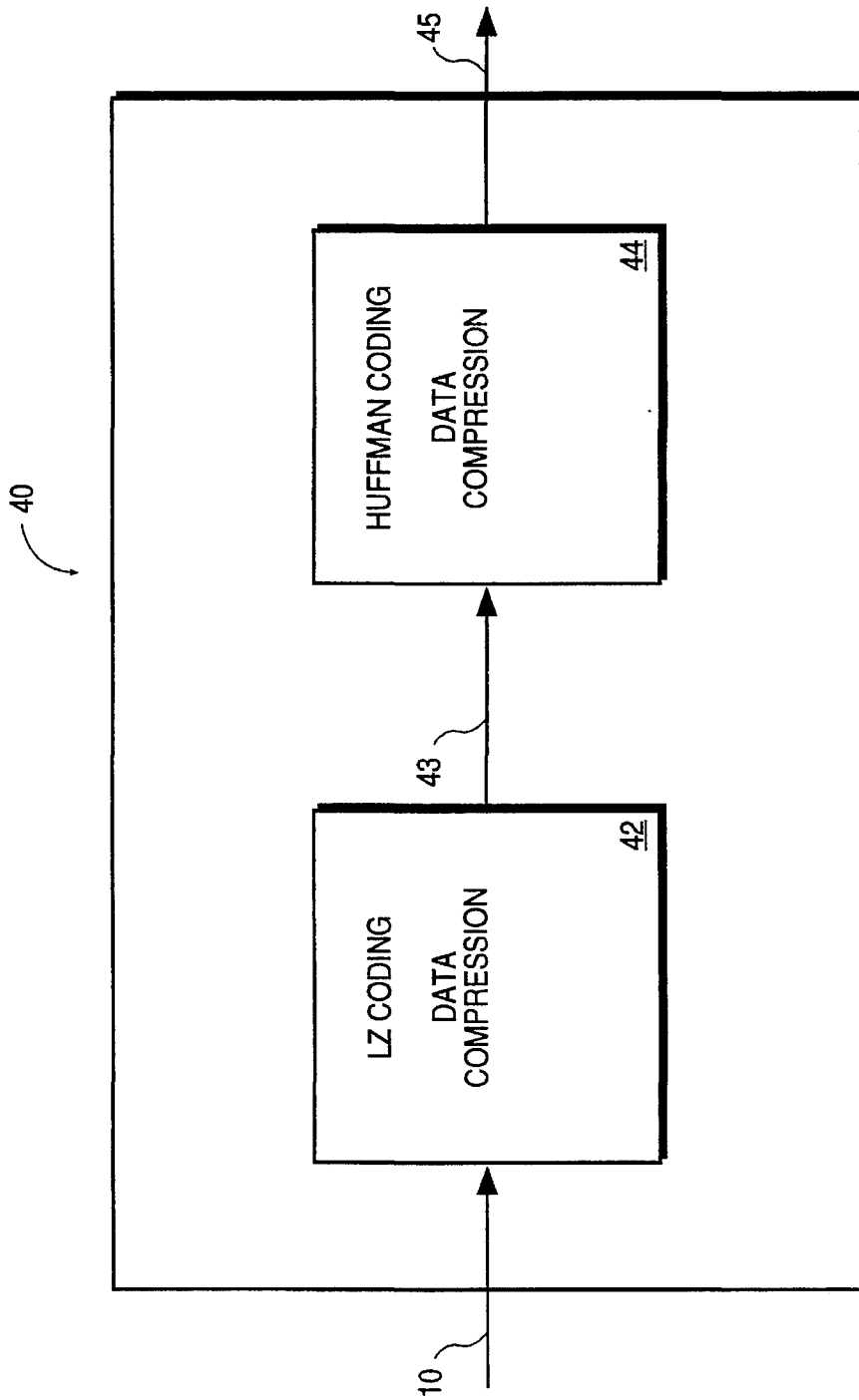

FIG. 3 (PRIOR ART)

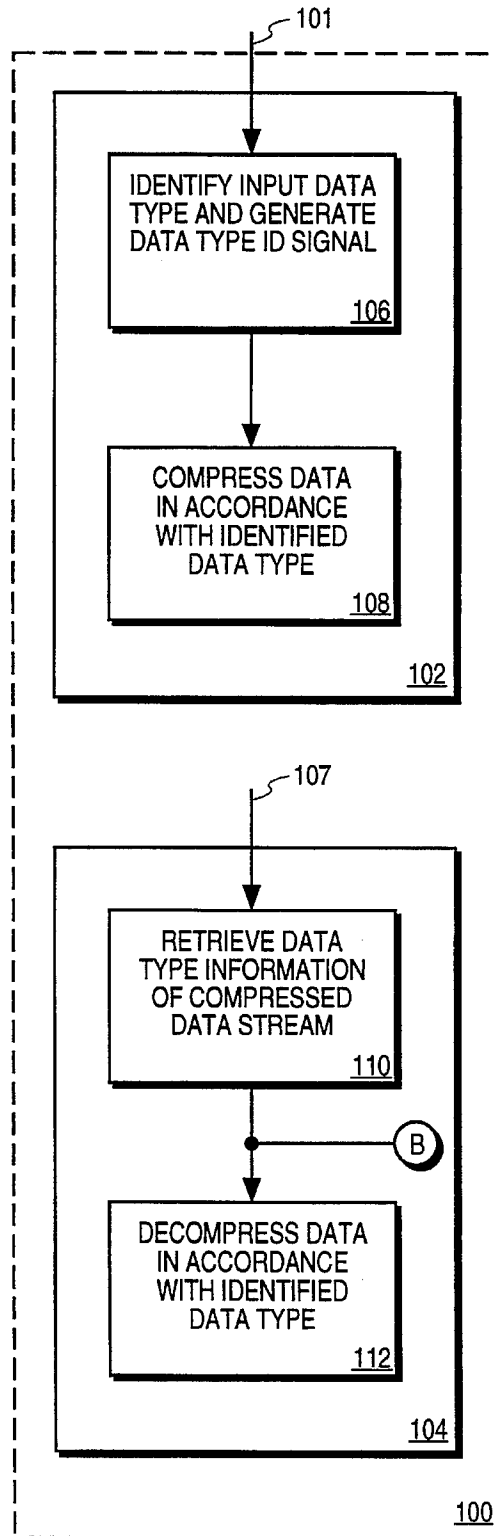

FIG. 4

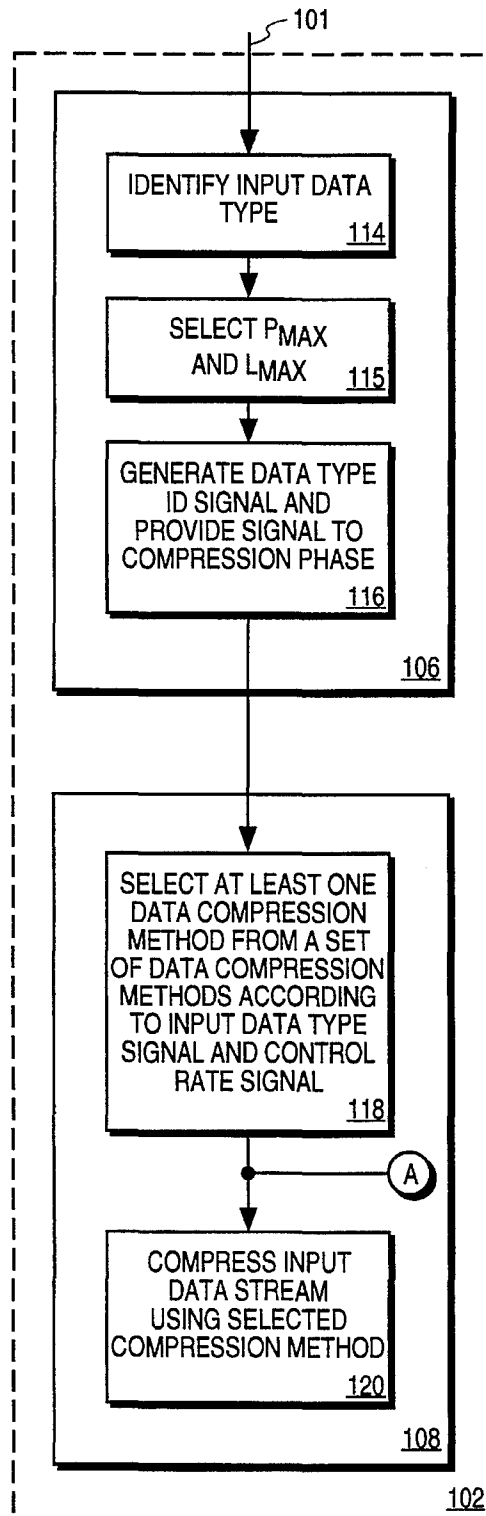

FIG. 5

Explore Litigation Insights

Docket Alarm provides insights to develop a more informed litigation strategy and the peace of mind of knowing you're on top of things.

Real-Time Litigation Alerts



Keep your litigation team up-to-date with **real-time alerts** and advanced team management tools built for the enterprise, all while greatly reducing PACER spend.

Our comprehensive service means we can handle Federal, State, and Administrative courts across the country.

Advanced Docket Research



With over 230 million records, Docket Alarm's cloud-native docket research platform finds what other services can't. Coverage includes Federal, State, plus PTAB, TTAB, ITC and NLRB decisions, all in one place.

Identify arguments that have been successful in the past with full text, pinpoint searching. Link to case law cited within any court document via Fastcase.

Analytics At Your Fingertips



Learn what happened the last time a particular judge, opposing counsel or company faced cases similar to yours.

Advanced out-of-the-box PTAB and TTAB analytics are always at your fingertips.

API

Docket Alarm offers a powerful API (application programming interface) to developers that want to integrate case filings into their apps.

LAW FIRMS

Build custom dashboards for your attorneys and clients with live data direct from the court.

Automate many repetitive legal tasks like conflict checks, document management, and marketing.

FINANCIAL INSTITUTIONS

Litigation and bankruptcy checks for companies and debtors.

E-DISCOVERY AND LEGAL VENDORS

Sync your system to PACER to automate legal marketing.