

Ex. 1011



US008777449B2

(12) **United States Patent**  
**Van De Ven et al.**

(10) **Patent No.:** **US 8,777,449 B2**  
(45) **Date of Patent:** **Jul. 15, 2014**

(54) **LIGHTING DEVICES COMPRISING SOLID STATE LIGHT EMITTERS**

(75) Inventors: **Antony Paul Van De Ven**, Hong Kong (CN); **Wai Kwan Chan**, Hong Kong (CN); **Ho Chin Wah**, Hong Kong (CN)

(73) Assignee: **Cree, Inc.**, Durham, NC (US)

(\* ) Notice: Subject to any disclaimer, the term of this patent is extended or adjusted under 35 U.S.C. 154(b) by 319 days.

(21) Appl. No.: **12/566,861**

(22) Filed: **Sep. 25, 2009**

(65) **Prior Publication Data**

US 2011/0075422 A1 Mar. 31, 2011

(51) **Int. Cl.**  
**F21S 4/00** (2006.01)

(52) **U.S. Cl.**  
USPC ..... **362/249.02**; 362/401; 362/407; 362/640; 362/646

(58) **Field of Classification Search**  
USPC ..... 362/340, 646, 650, 249.02, 401, 407  
See application file for complete search history.

(56) **References Cited**

U.S. PATENT DOCUMENTS

446,142 A	2/1891	Martin
D188,916 S	9/1960	Harling
D207,867 S	6/1967	Pettengill
3,560,728 A	2/1971	Atkin
3,755,697 A	8/1973	Miller
3,787,752 A	1/1974	Delay
4,090,189 A	5/1978	Fisler
4,717,868 A	1/1988	Peterson
4,798,983 A	1/1989	Mori

4,839,535 A	6/1989	Miller
4,841,422 A	6/1989	Groh
4,918,487 A	4/1990	Coulter, Jr.
5,138,541 A	8/1992	Kano
5,151,679 A	9/1992	Dimmick
5,175,528 A	12/1992	Choi et al.
5,345,167 A	9/1994	Hasegawa et al.
5,397,938 A	3/1995	Wilheim et al.
5,528,467 A	6/1996	Jiang

(Continued)

FOREIGN PATENT DOCUMENTS

CN	101162745	4/2008
EP	1 881 259	1/2008

(Continued)

OTHER PUBLICATIONS

U.S. Appl No. 29/344,219, filed Sep. 25, 2009, Van de Ven.

(Continued)

*Primary Examiner* — Anabel Ton  
(74) *Attorney, Agent, or Firm* — Burr & Brown, PLLC

(57) **ABSTRACT**

A lighting device comprising a trim element, an electrical connector and at least one solid state light emitter, the lighting device weighing less than one kilogram. If current of about 12 watts (or in some cases about 15 watts, or in some cases not more than about 15 watts) is supplied to the electrical connector, the at least one solid state light emitter will illuminate so that the lighting device will emit white light of at least 500 lumens. Also, a lighting device that weighs less than one kilogram and can generate white light of at least 500 lumens using a current of not more than about 15 watts. Also, a lighting device for mounting in a recessed housing, comprising a unitary structure trim element that conducts heat away from at least one solid state light emitter and dissipates at least some of the heat outside of the recessed housing.

**14 Claims, 5 Drawing Sheets**

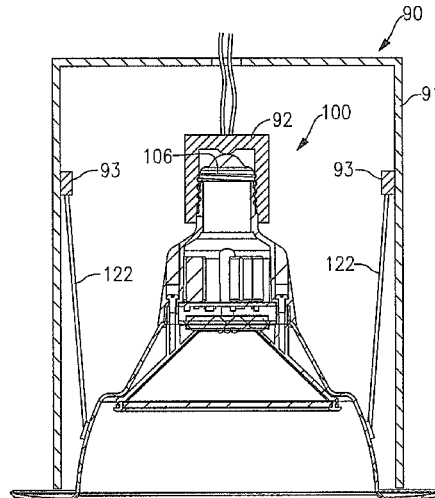

(56)

References Cited

U.S. PATENT DOCUMENTS

5,631,190	A	5/1997	Negley	7,862,214	B2	1/2011	Trott et al.
5,661,645	A	8/1997	Hochstein	7,871,184	B2	1/2011	Peng
D384,430	S	9/1997	Lecluze	D633,099	S	2/2011	Van de Ven et al.
5,736,881	A	4/1998	Ortiz	7,914,902	B2	3/2011	Kao et al.
5,803,579	A	9/1998	Turnbull et al.	D636,921	S	4/2011	Van de Ven et al.
D400,280	S	10/1998	Leen	D636,922	S	4/2011	Yoshida et al.
5,844,377	A	12/1998	Anderson et al.	D638,160	S	5/2011	Van de Ven et al.
5,912,477	A	6/1999	Negley	7,994,725	B2	8/2011	Bouchard
5,912,568	A	6/1999	Kiley	8,008,845	B2	8/2011	Van de Ven
D418,620	S	1/2000	Grossman	D646,011	S	9/2011	Rashidi
D425,024	S	5/2000	Klaus et al.	8,157,422	B2	4/2012	Paik et al.
6,079,852	A	6/2000	Kamaya et al.	8,235,555	B2	8/2012	Thomas et al.
6,150,771	A	11/2000	Perry	8,246,202	B2	8/2012	Mart et al.
6,161,910	A	12/2000	Reisenauer et al.	2002/0097095	A1	7/2002	Jeon et al.
D437,439	S	2/2001	Tang	2005/0007164	A1	1/2005	Callahan
6,222,172	B1	4/2001	Fossum et al.	2005/0111222	A1	5/2005	Olsson et al.
6,264,354	B1	7/2001	Motilal	2005/0128752	A1	6/2005	Ewington et al.
6,285,139	B1	9/2001	Ghanem	2005/0169015	A1	8/2005	Luk et al.
6,329,760	B1	12/2001	Bebenroth	2005/0174065	A1	8/2005	Janning
6,340,868	B1	1/2002	Lys et al.	2005/0242742	A1	11/2005	Cheang et al.
6,350,041	B1	2/2002	Tarsa et al.	2005/0276053	A1	12/2005	Nortrup et al.
6,362,578	B1	3/2002	Swanson et al.	2006/0244396	A1	11/2006	Bucur
6,388,393	B1	5/2002	Illingworth	2006/0255753	A1	11/2006	Sawada et al.
6,400,101	B1	6/2002	Biebl et al.	2007/0108843	A1	5/2007	Preston et al.
6,528,954	B1	3/2003	Lys et al.	2007/0137074	A1	6/2007	Van de Ven
6,577,072	B2	6/2003	Saito et al.	2007/0139920	A1	6/2007	Van de Ven
6,586,890	B2	7/2003	Min et al.	2007/0139923	A1	6/2007	Negley
6,600,175	B1	7/2003	Baretz et al.	2007/0170447	A1	7/2007	Negley
6,614,358	B1	9/2003	Hutchison et al.	2007/0171145	A1	7/2007	Coleman
6,636,003	B2	10/2003	Rahm et al.	2007/0215027	A1	9/2007	MacDonald et al.
6,724,376	B2	4/2004	Sakura et al.	2007/0236911	A1	10/2007	Negley
D490,181	S	5/2004	Redfern	2007/0236920	A1	10/2007	Snyder
6,747,420	B2	6/2004	Barth et al.	2007/0247414	A1	10/2007	Roberts
6,755,550	B1*	6/2004	Lackey ..... 362/147	2007/0263393	A1	11/2007	Van de Ven
6,791,840	B2	9/2004	Chun	2007/0267983	A1	11/2007	Van de Ven
6,808,287	B2	10/2004	Lebens et al.	2007/0274063	A1	11/2007	Negley
6,836,081	B2	12/2004	Swanson et al.	2007/0274080	A1	11/2007	Negley
6,841,947	B2	1/2005	Berg-johansen	2007/0278503	A1	12/2007	Van de Ven
6,873,203	B1	3/2005	Latham, II et al.	2007/0278934	A1	12/2007	Van de Ven
6,987,787	B1	1/2006	Mick	2007/0278974	A1	12/2007	Van de Ven
6,995,518	B2	2/2006	Havlik et al.	2007/0279440	A1	12/2007	Negley
7,014,341	B2*	3/2006	King et al. .... 362/296.02	2007/0279903	A1	12/2007	Negley
7,038,399	B2	5/2006	Lys et al.	2007/0280624	A1	12/2007	Negley
7,071,762	B2	7/2006	Xu et al.	2008/0030993	A1	2/2008	Narendran et al.
7,081,722	B1	7/2006	Huynh et al.	2008/0054281	A1	3/2008	Narendran et al.
7,088,059	B2	8/2006	McKinney et al.	2008/0084685	A1	4/2008	Van de Ven
7,108,238	B2	9/2006	Gauci	2008/0084700	A1	4/2008	Van de Ven
7,119,498	B2	10/2006	Baldwin et al.	2008/0084701	A1	4/2008	Van de Ven
7,144,140	B2	12/2006	Sun et al.	2008/0088248	A1	4/2008	Myers
7,180,487	B2	2/2007	Kamikawa et al.	2008/0089053	A1	4/2008	Negley
7,202,608	B2	4/2007	Robinson et al.	2008/0089071	A1	4/2008	Wang
7,213,940	B1	5/2007	Van de Ven	2008/0094000	A1	4/2008	Yamamoto et al.
D544,979	S	6/2007	Hartmann et al.	2008/0094829	A1	4/2008	Narendran et al.
7,226,189	B2	6/2007	Lee et al.	2008/0105887	A1	5/2008	Narendran et al.
D557,853	S	12/2007	Sandell	2008/0106895	A1	5/2008	Van de Ven
D558,374	S	12/2007	Sandell	2008/0106907	A1	5/2008	Trott
7,408,308	B2	8/2008	Sawada et al.	2008/0112168	A1	5/2008	Pickard
D576,964	S	9/2008	Shaner	2008/0112170	A1	5/2008	Trott
7,458,706	B1	12/2008	Liu et al.	2008/0112183	A1	5/2008	Negley
7,513,639	B2	4/2009	Wang	2008/0117500	A1	5/2008	Narendran et al.
7,566,154	B2	7/2009	Gloisten et al.	2008/0128718	A1	6/2008	Sumitani
7,614,767	B2*	11/2009	Zulim et al. .... 362/296.01	2008/0130285	A1	6/2008	Negley
7,614,769	B2*	11/2009	Sell ..... 362/365	2008/0136313	A1	6/2008	Van de Ven
7,628,513	B2	12/2009	Chiu	2008/0137347	A1	6/2008	Trott
7,637,635	B2	12/2009	Xiao et al.	2008/0186704	A1	8/2008	Chou et al.
D610,291	S	2/2010	Yoshinobu et al.	2008/0211415	A1	9/2008	Altamura
7,677,767	B2	3/2010	Chyn	2008/0259589	A1	10/2008	Van de Ven
D618,376	S	6/2010	Redfern et al.	2008/0278928	A1	11/2008	Van de Ven
7,758,223	B2	7/2010	Osawa et al.	2008/0278940	A1	11/2008	Van de Ven
7,780,318	B2	8/2010	Xiao	2008/0278950	A1	11/2008	Pickard et al.
D625,038	S	10/2010	Yoo	2008/0278952	A1	11/2008	Trott
D627,502	S	11/2010	Zheng et al.	2008/0278957	A1	11/2008	Pickard et al.
D627,911	S	11/2010	Mo et al.	2008/0304260	A1	12/2008	Van de Ven
				2008/0304261	A1	12/2008	Van de Ven

(56) **References Cited**  
U.S. PATENT DOCUMENTS

2009/0034283 A1 2/2009 Albright et al.  
 2009/0046464 A1 2/2009 Liu et al.  
 2009/0059582 A1 3/2009 Kulkarni  
 2009/0086474 A1 4/2009 Chou  
 2009/0101930 A1 4/2009 Li  
 2009/0108269 A1 4/2009 Negley  
 2009/0147517 A1 6/2009 Li et al.  
 2009/0160363 A1 6/2009 Negley  
 2009/0161356 A1 6/2009 Negley  
 2009/0184616 A1 7/2009 Van de Ven  
 2009/0184662 A1 7/2009 Given et al.  
 2009/0184666 A1 7/2009 Myers  
 2009/0196037 A1 8/2009 Xiao et al.  
 2009/0296384 A1 12/2009 Van de Ven  
 2010/0014289 A1 1/2010 Thomas et al.  
 2010/0027258 A1 2/2010 Maxik et al.  
 2010/0060130 A1 3/2010 Li  
 2010/0060175 A1 3/2010 Lethellier  
 2010/0067227 A1 3/2010 Budike  
 2010/0079059 A1 4/2010 Roberts et al.  
 2010/0079262 A1 4/2010 Van Laanen  
 2010/0102199 A1 4/2010 Negley et al.  
 2010/0102697 A1 4/2010 Van De Ven et al.  
 2010/0103678 A1 4/2010 Van De Ven et al.  
 2010/0109570 A1 5/2010 Weaver  
 2010/0135016 A1 6/2010 Ishibashi  
 2010/0177509 A1 7/2010 Pickard  
 2010/0225220 A1 9/2010 Tanaka et al.  
 2010/0246177 A1 9/2010 Van de Ven  
 2010/0246197 A1 9/2010 Takahashi et al.  
 2010/0308739 A1 12/2010 Shteynberg et al.  
 2010/0327746 A1 12/2010 Hisayasu  
 2011/0031894 A1 2/2011 Van de Ven  
 2011/0068696 A1 3/2011 Van de Ven  
 2011/0068702 A1 3/2011 Van de Ven  
 2011/0074265 A1 3/2011 Van de Ven et al.  
 2011/0074289 A1 3/2011 Van de Ven  
 2011/0075411 A1 3/2011 Van de Ven et al.  
 2011/0075414 A1 3/2011 Van de Ven et al.  
 2011/0075422 A1 3/2011 Van de Ven et al.  
 2011/0075423 A1 3/2011 Van de Ven  
 2011/0169417 A1 7/2011 Hum et al.  
 2011/0180818 A1 7/2011 Lerman et al.  
 2011/0181194 A1 7/2011 Hum et al.  
 2011/0198984 A1 8/2011 Van de Ven  
 2011/0211351 A1 9/2011 Van de Ven

## FOREIGN PATENT DOCUMENTS

WO 2006/007388 1/2006  
 WO 2008/036873 3/2008

WO 2008/051957 5/2008  
 WO 2008/061082 5/2008  
 WO 2008/129504 10/2008

## OTHER PUBLICATIONS

U.S. Appl. No. 29/353,900, filed Jan. 15, 2010, Van de Ven.  
 U.S. Appl. No. 12/535,319, filed Aug. 4, 2009.  
 U.S. Appl. No. 12/441,905, filed Mar. 26, 2009.  
 U.S. Appl. No. 12/566,936, filed Sep. 25, 2009.  
 U.S. Appl. No. 12/566,850, filed Sep. 25, 2009.  
 U.S. Appl. No. 12/566,857, filed Sep. 25, 2009.  
 U.S. Appl. No. 12/621,970, filed Nov. 19, 2009.  
 U.S. Appl. No. 12/704,995, filed Feb. 12, 2010.  
 U.S. Appl. No. 12/566,142, filed Sep. 24, 2009.  
 U.S. Appl. No. 12/566,195, filed Sep. 24, 2009.  
 "Assist Recommends . . . LED Life for General Lighting: Definition of Life", vol. 1, Issue 1, Feb. 2005.  
 "Bright Tomorrow Lighting Competition (L prize™)", May 28, 2008, Document No. 08NT006643.  
 "Energy Star™ Program Requirements for Solid State Lighting Luminaires, Eligibility Criteria—Version 1.1", Final: Dec. 19, 2008. Application Note: CLD-AP06.006, entitled Cree® XLamp® XR Family & 4550 LED Reliability, published at cree.com/xlamp, Sep. 2008.  
 Bulborama, Lighting Terms Reference and Glossary, <http://www.bulborama.com/storelightingreferenceglossary-13.html>, 6 pages.  
 DuPont, "DuPont™ Diffuse Light Reflector", Publication K-20044, May 2008, 2 pages.  
 Furukawa Electric Co., Ltd., Data Sheet, "New Material for Illuminated Panels Microcellular Reflective Sheet MCPET", updated Apr. 8, 2008, 2 pages.  
 Illuminating Engineering Society Standard LM-80-08, entitled "IES Approved Method for Measuring Lumen Maintenance of LED Light Sources", Sep. 22, 2008, ISBN No. 978-0-87995.227-3.  
 Kim et al., "Strongly Enhanced Phosphor Efficiency in GaInN White Light-Emitting Diodes Using Remote Phosphor Configuration and Diffuse Reflector Cup" *Japanese Journal of Applied Physics* 44(21):L649-L651 (2005).  
 LEDs Magazine, Press Release May 23, 2007, "Furukawa America Debuts MCPET Reflective Sheets to Improve Clarity, Efficiency of Lighting Fixtures", downloaded Jun. 25, 2009 from <http://www.ledsmagazine.com/press/15145>, 2 pages.  
 Philips Lumileds, Technology White Paper: "Understanding power LED lifetime analysis", downloaded from <http://www.philipslumileds.com/pdfs/WP12.pdf>, Document No. WP12, Last Modified May 22, 2007.  
 MCPET—Microcellular Reflective Sheet Properties, <http://www.trocullen.com>, downloaded Jun. 25, 2009, 2 pages.  
 Chinese Office Action (and translation provided by foreign counsel) from a corresponding Chinese patent application bearing a mailing date of Dec. 19, 2013, 14 pages.

\* cited by examiner

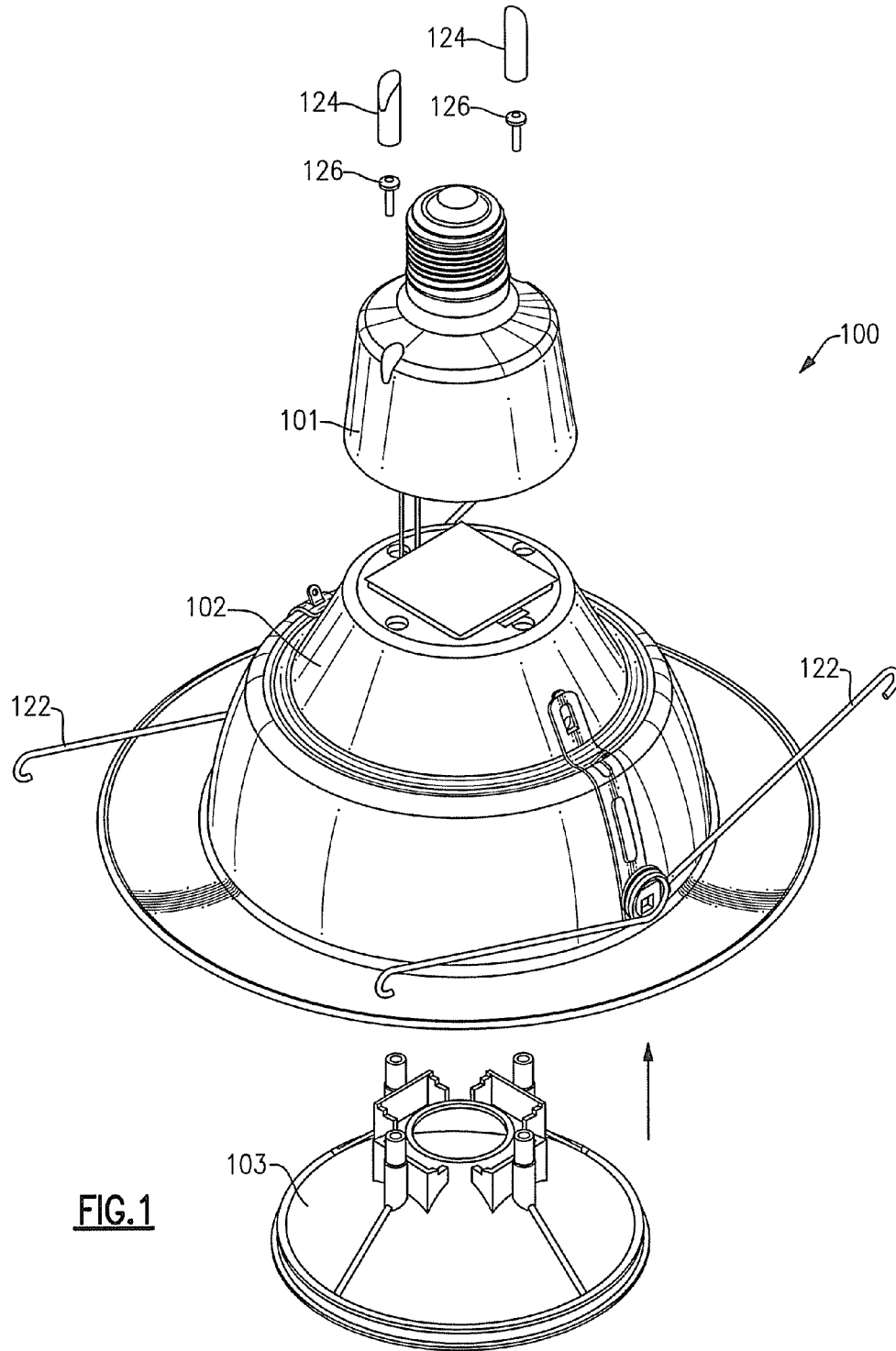

# Explore Litigation Insights

Docket Alarm provides insights to develop a more informed litigation strategy and the peace of mind of knowing you're on top of things.

## Real-Time Litigation Alerts



Keep your litigation team up-to-date with **real-time alerts** and advanced team management tools built for the enterprise, all while greatly reducing PACER spend.

Our comprehensive service means we can handle Federal, State, and Administrative courts across the country.

## Advanced Docket Research



With over 230 million records, Docket Alarm's cloud-native docket research platform finds what other services can't. Coverage includes Federal, State, plus PTAB, TTAB, ITC and NLRB decisions, all in one place.

Identify arguments that have been successful in the past with full text, pinpoint searching. Link to case law cited within any court document via Fastcase.

## Analytics At Your Fingertips



Learn what happened the last time a particular judge, opposing counsel or company faced cases similar to yours.

Advanced out-of-the-box PTAB and TTAB analytics are always at your fingertips.

## API

Docket Alarm offers a powerful API (application programming interface) to developers that want to integrate case filings into their apps.

## LAW FIRMS

Build custom dashboards for your attorneys and clients with live data direct from the court.

Automate many repetitive legal tasks like conflict checks, document management, and marketing.

## FINANCIAL INSTITUTIONS

Litigation and bankruptcy checks for companies and debtors.

## E-DISCOVERY AND LEGAL VENDORS

Sync your system to PACER to automate legal marketing.