



US007036207B2

(12) **United States Patent**
Neal

(10) **Patent No.:** **US 7,036,207 B2**
(45) **Date of Patent:** **May 2, 2006**

(54) **STATOR ASSEMBLY MADE FROM A PLURALITY OF TOROIDAL CORE SEGMENTS AND MOTOR USING SAME**

(75) Inventor: **Griffith D. Neal**, Alameda, CA (US)

(73) Assignee: **Encap Motor Corporation**, Alameda, CA (US)

(*) Notice: Subject to any disclaimer, the term of this patent is extended or adjusted under 35 U.S.C. 154(b) by 0 days.

(21) Appl. No.: **09/798,511**

(22) Filed: **Mar. 2, 2001**

(65) **Prior Publication Data**
US 2002/0135263 A1 Sep. 26, 2002

(51) **Int. Cl.**
H02K 15/00 (2006.01)
H02K 1/14 (2006.01)

(52) **U.S. Cl.** **29/597; 29/596; 29/606; 310/45; 310/218**

(58) **Field of Classification Search** 29/596, 29/598, 597, 605, 606, 732; 310/214, 216, 310/45, 154, 156, 218
See application file for complete search history.

(56) **References Cited**

U.S. PATENT DOCUMENTS

3,590,328 A	6/1971	Frescura	
3,638,055 A	1/1972	Zimmermann	
3,802,066 A	4/1974	Barrett	
3,874,073 A	4/1975	Dochterman et al.	
3,908,138 A *	9/1975	Shieh	310/29
3,942,054 A	3/1976	Kristen et al.	
3,979,530 A	9/1976	Schwider et al.	
4,015,154 A *	3/1977	Tanaka et al.	310/42
4,128,527 A *	12/1978	Kinjo et al.	310/43
4,173,822 A	11/1979	Futterer et al.	
4,352,897 A	10/1982	Ogata et al.	
4,365,180 A *	12/1982	Licata et al.	310/216

4,372,035 A	2/1983	McMillen
4,387,311 A	6/1983	Kobayashi et al.
4,492,889 A	1/1985	Fukushi et al.
4,572,979 A	2/1986	Haar et al.
4,643,346 A	2/1987	Gotoh
4,679,313 A	7/1987	Schultz et al.
4,712,035 A	12/1987	Forbes et al.
4,760,299 A	7/1988	Dickie et al.
4,801,833 A	1/1989	Dye
4,853,576 A	8/1989	Mayumi et al.

(Continued)

FOREIGN PATENT DOCUMENTS

BE 870878 1/1979

(Continued)

OTHER PUBLICATIONS

G.D. Neal et al. "Ceramic Filled Thermoplastic Encapsulation as a Design Feature for a BLDC Motor in a Disk Drive" IEEE 2000.*

(Continued)

Primary Examiner—Eric Compton

(74) *Attorney, Agent, or Firm*—Brinks Hofer Gilson & Lione

(57) **ABSTRACT**

A plurality of stator arc segments form a toroidal core for a stator assembly used to make a motor. In a preferred embodiment, a plurality of magnetic fields is created when electrical current is conducted through wire wound around poles on the toroidal core. A monolithic body of phase change material substantially encapsulates the conductors and holds the stator arc segments in contact with each other in the toroidal core. Hard disc drives using the motor, and methods of constructing the motor and hard disc drives are also disclosed.

29 Claims, 6 Drawing Sheets

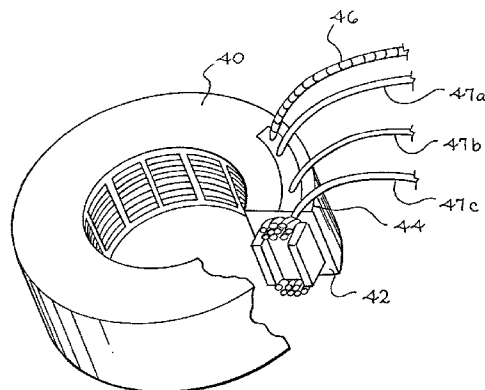
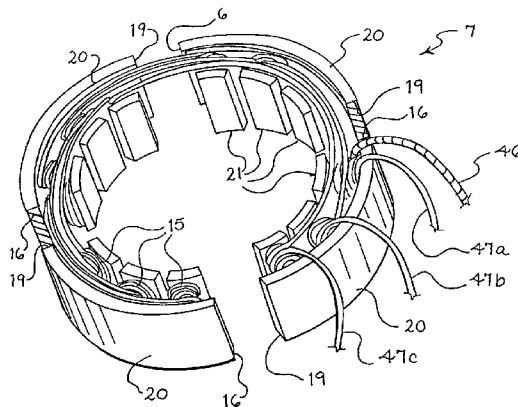

U.S. PATENT DOCUMENTS

4,858,073 A 8/1989 Gregory
 4,868,970 A 9/1989 Schultz et al.
 4,954,739 A 9/1990 Schultz et al.
 4,990,809 A * 2/1991 Artus et al. 310/192
 5,008,572 A 4/1991 Marshall et al.
 5,036,580 A 8/1991 Fox et al.
 5,073,735 A 12/1991 Takagi
 5,075,585 A 12/1991 Teruyama et al.
 5,121,021 A 6/1992 Ward
 5,134,327 A * 7/1992 Sumi et al. 310/43
 5,142,103 A 8/1992 Stine
 5,147,982 A 9/1992 Steffen
 5,191,698 A * 3/1993 Sumi et al. 29/596
 5,206,554 A 4/1993 Perrot
 5,212,419 A * 5/1993 Fisher et al. 310/254
 5,268,607 A 12/1993 McManus
 5,334,897 A 8/1994 Ineson et al.
 5,345,129 A 9/1994 Molnar
 5,382,852 A 1/1995 Yuhi et al.
 5,396,210 A 3/1995 Purohit et al.
 5,400,218 A 3/1995 Val
 5,414,317 A 5/1995 Reid et al.
 5,459,190 A 10/1995 Nakamura et al.
 5,461,772 A 10/1995 Puri
 5,500,780 A 3/1996 Boutaghou et al.
 5,506,458 A 4/1996 Pace et al.
 5,541,787 A 7/1996 Jabbari et al.
 5,548,458 A 8/1996 Pelstring et al.
 5,558,445 A 9/1996 Chen et al.
 5,579,188 A 11/1996 Dunfield et al.
 5,587,617 A 12/1996 Dunfield et al.
 5,592,731 A * 1/1997 Huang et al. 29/596
 5,598,048 A 1/1997 Dunfield et al.
 5,610,463 A 3/1997 Dunfield et al.
 5,619,083 A 4/1997 Dunfield et al.
 5,619,389 A 4/1997 Dunfield et al.
 5,621,372 A 4/1997 Purohit
 5,633,545 A 5/1997 Albrecht et al.
 5,666,242 A 9/1997 Edwards et al.
 5,668,427 A 9/1997 Morita
 5,672,927 A 9/1997 Viskochil
 5,675,196 A 10/1997 Huang et al.
 5,694,268 A 12/1997 Dunfield et al.
 5,698,919 A 12/1997 Obara
 5,728,600 A 3/1998 Saxelby, Jr. et al.
 5,729,072 A * 3/1998 Hirano et al. 310/258
 5,729,404 A 3/1998 Dunfield et al.
 5,742,450 A 4/1998 Moser
 5,751,085 A 5/1998 Hayashi
 5,751,514 A 5/1998 Hyde et al.
 5,766,535 A 6/1998 Ong
 5,783,888 A 7/1998 Yamano
 5,806,169 A * 9/1998 Trago et al. 29/596
 5,814,412 A 9/1998 Terada et al.
 5,850,318 A 12/1998 Dunfield et al.
 5,859,486 A * 1/1999 Nakahara et al. 310/254
 5,875,540 A 3/1999 Sargeant et al.
 5,880,179 A 3/1999 Ito et al.
 5,881,447 A 3/1999 Molnar
 5,898,252 A 4/1999 Tanaka et al.
 5,918,360 A 7/1999 Fornes et al.
 5,942,824 A 8/1999 Shioya et al.

5,949,172 A 9/1999 Katagiri
 5,958,466 A 9/1999 Ong
 5,973,424 A 10/1999 Engelberger et al.
 5,982,057 A 11/1999 Imada et al.
 5,986,365 A 11/1999 Kuwert et al.
 5,986,377 A 11/1999 Yamada et al.
 5,990,247 A 11/1999 Terada et al.
 6,002,185 A 12/1999 Nakao et al.
 6,019,516 A 2/2000 Leuthold et al.
 6,020,661 A 2/2000 Trago et al.
 6,034,841 A 3/2000 Albrecht et al.
 6,043,583 A 3/2000 Kurosawa et al.
 6,049,153 A * 4/2000 Nishiyama et al. 310/156.53
 6,071,014 A 6/2000 Lee et al.
 6,075,304 A 6/2000 Nakatsuka
 6,153,959 A 11/2000 Lorenzo
 6,163,952 A 12/2000 Takehara
 6,167,610 B1 1/2001 Nakahara et al.
 6,201,334 B1 3/2001 Sargeant et al.
 6,265,800 B1 7/2001 Kimura et al.
 6,265,804 B1 * 7/2001 Nitta et al. 310/259
 6,359,355 B1 * 3/2002 Hartsfield et al. 310/89
 6,362,553 B1 * 3/2002 Nakahara et al. 310/254
 6,509,665 B1 * 1/2003 Nishiyama et al. 310/215
 6,844,636 B1 * 1/2005 Lieu et al. 310/43
 6,856,065 B1 * 2/2005 Suzuki et al. 310/218

FOREIGN PATENT DOCUMENTS

BE 891258 3/1982
 DE 25 39 492 A1 3/1977
 DE 2653387 * 6/1978
 EP 0 747 943 A2 12/1996
 EP 0 883 171 A1 12/1998
 EP 0938181 * 8/1999
 FR 2 647 958 12/1990
 JP 01-138936 * 5/1989
 JP 04-029536 * 1/1992
 JP 05336722 12/1993
 JP 06-327208 * 11/1994
 JP 10070870 3/1998
 JP 410271719 10/1998
 JP 11082508 3/1999
 JP 10-243595 * 9/1999
 SU 1334297 8/1987
 SU 1494148 7/1989
 WO WO 92/06532 4/1992
 WO WO 96/20501 7/1996
 WO WO 96/33533 10/1996
 WO WO 97/39870 10/1997

OTHER PUBLICATIONS

LNP Engineering Plastics, Advertisement entitled "Konduiit™ Thermally Conductive Composites," undated (2 pages).
 LNP Engineering Plastics, Press Release entitled "LNP Introduces First-Ever Line of Thermally Conductive Compounds," Jan. 28, 1999 (2 pages).
 Search Report for Patent Cooperation Treaty application No. PCT/US02/06508, Date of Mailing Jul. 12, 2002, 3 pages.

* cited by examiner

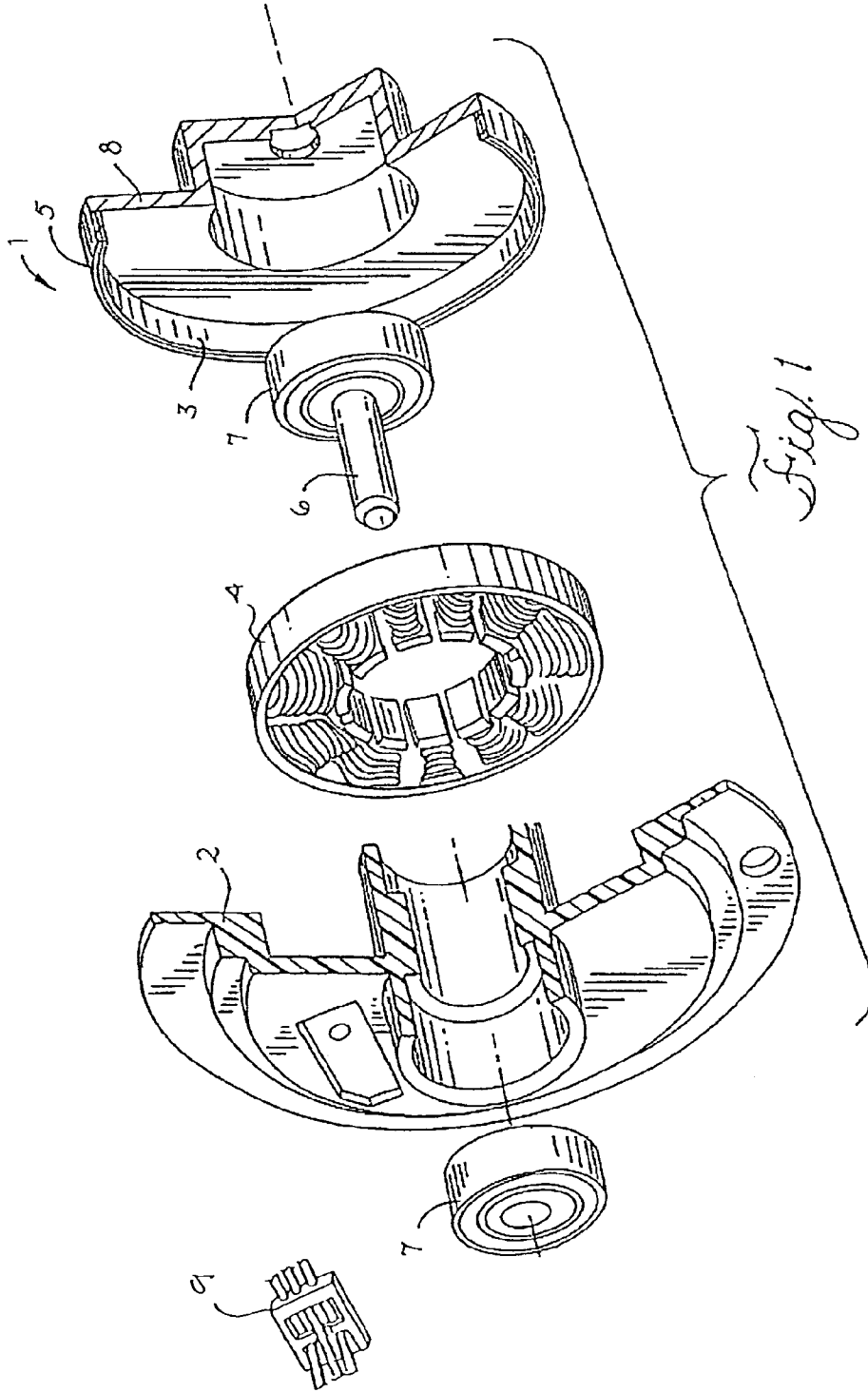

Fig. 1

Prior Art

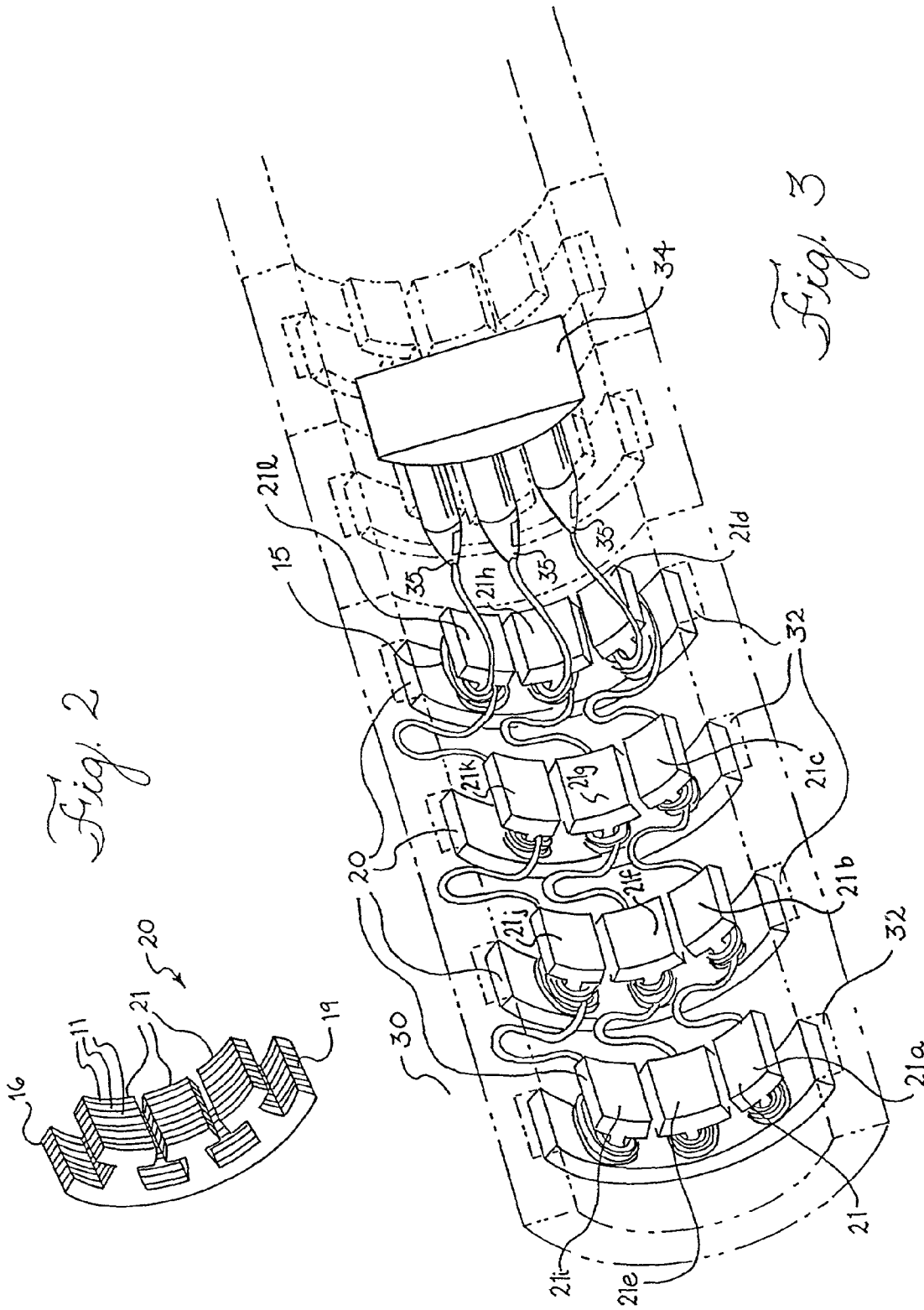

Fig. 2

Fig. 3

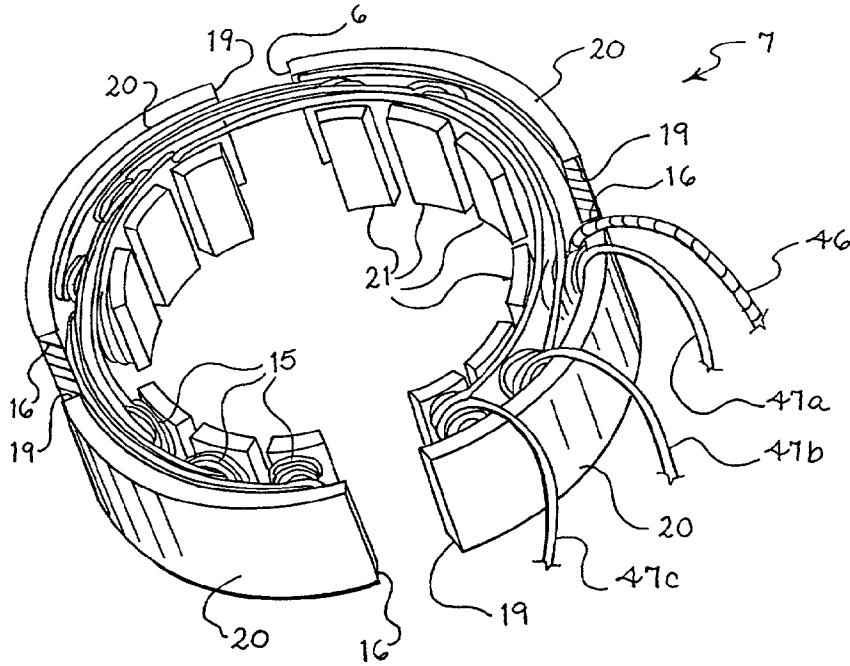

Fig. 4

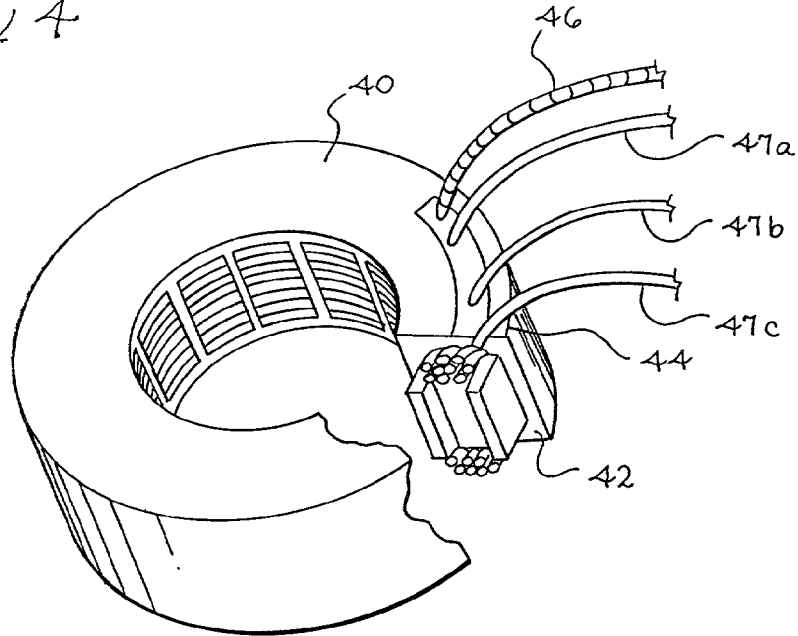

Fig. 5

Explore Litigation Insights

Docket Alarm provides insights to develop a more informed litigation strategy and the peace of mind of knowing you're on top of things.

Real-Time Litigation Alerts



Keep your litigation team up-to-date with **real-time alerts** and advanced team management tools built for the enterprise, all while greatly reducing PACER spend.

Our comprehensive service means we can handle Federal, State, and Administrative courts across the country.

Advanced Docket Research



With over 230 million records, Docket Alarm's cloud-native docket research platform finds what other services can't. Coverage includes Federal, State, plus PTAB, TTAB, ITC and NLRB decisions, all in one place.

Identify arguments that have been successful in the past with full text, pinpoint searching. Link to case law cited within any court document via Fastcase.

Analytics At Your Fingertips



Learn what happened the last time a particular judge, opposing counsel or company faced cases similar to yours.

Advanced out-of-the-box PTAB and TTAB analytics are always at your fingertips.

API

Docket Alarm offers a powerful API (application programming interface) to developers that want to integrate case filings into their apps.

LAW FIRMS

Build custom dashboards for your attorneys and clients with live data direct from the court.

Automate many repetitive legal tasks like conflict checks, document management, and marketing.

FINANCIAL INSTITUTIONS

Litigation and bankruptcy checks for companies and debtors.

E-DISCOVERY AND LEGAL VENDORS

Sync your system to PACER to automate legal marketing.