

## Design of a Low-cost Physiological Parameter Measurement and Monitoring Device

G. Sen Gupta<sup>1</sup>, S.C. Mukhopadhyay<sup>2</sup>, B.S. Devlin<sup>2</sup> and S. Demidenko<sup>2</sup>

<sup>1</sup>School of Electrical and Electronic Engineering, Singapore Polytechnic, 500 Dover Road, Singapore

<sup>2</sup>Institute of Information Sciences and Technology, Massey University, Palmerston North, New Zealand

Email: s.c.mukhopadhyay@massey.ac.nz, SenGupta@sp.edu.sg, b.s.devlin@massey.ac.nz, s.demidenko@massey.ac.nz

**Abstract** – In this paper we present the design of a low-cost system that can be used to monitor physiological parameters, such as temperature and heart rate, of a human subject. The system consists of an electronic device which is worn on the wrist and finger, by an elderly or at-risk person. Using several sensors to measure different vital signs, the person is wirelessly monitored within his own home. An impact sensor has been used to detect falls. The device detects if a person is medically distressed and sends an alarm to a receiver unit that is connected to a computer. This sets off an alarm, allowing help to be provided to the patient. The device is battery powered for use indoors. The device can be easily adapted to monitor athletes and infants. The low cost of the device will help to lower the cost of home monitoring of patients recovering from illness. A prototype of the device has been fabricated and extensively tested with very good results.

**Keywords** – physiological parameters, sensors, wireless transmission, home monitoring

### I. INTRODUCTION

Many elderly people dread the idea of being forced to live with their adult children, or in a rest home or in other sheltered living arrangement. They want to live independently and keep control of their own lives. Yet at the same time they know there is a high risk of injury or even death because of a fall or stroke. With the population aging in most developing countries, there will be more and more elderly people living alone in future. Such people need to be monitored continuously and provided with immediate medical help and attention when required.

The cost of hospitalization is ever increasing, so is the cost of rehabilitation after a major illness or surgery. Hospitals are looking at sending people back as soon as possible to recoup at home. During this recovery period several physiological parameters need to be continuously measured. Hence telemedicine and remote monitoring of patients at home are gaining added importance and urgency [1-3]. Today, the progress in science and technology offers miniaturization, speed, intelligence, sophistication and new materials at lower cost. In this new landscape, micro-technologies, information technologies and telecommunications are the key factors in inventing devices to assist mankind. Patients are being monitored using a network of wireless sensors [4]. A system to monitor the overall health of welfare facility residents, who need constant care, has been reported in [5]. This system [5] has been designed with wireless sensors, wireless repeaters and a host computer. The system consists of a piezoelectric

sensor, a 2 axis accelerometer, a microcontroller and a low power transceiver. It records respiration activity and indicators of posture for 24 hours. These data are transmitted to the wireless repeater by the transceiver. The wireless repeaters, which are installed throughout the welfare facility, send data, including the repeater's ID, to the host computer. The ID is used to detect the resident's location in the welfare facility. The host computer stores the data, which can be used to analyze the resident's overall health condition. When the resident is in an emergency situation, such as falling or in an inactive state for more than the allotted time, the host computer automatically alerts the situation to the care staff by an alarm sound and also by mobile phone. However, all reported systems are relatively expensive.

In the back drop of the importance of continuous monitoring of vital physiological parameters of a patient, our research was undertaken to design a low-cost smart monitoring device. It aims to provide peace-of-mind to users who have medical problems, but are not placed in a hospital for monitoring. Caregivers, who look after patients with mental or physical disabilities, can use this device when they are not able to visually supervise the patients.

Currently there are monitoring products in the market that are aimed to provide emergency assistance to senior citizens, rehabilitation patients, and medically or physically challenged individuals, but these have limitations. St John's and Medic Alert's Lifelink™ [6] allows the user to set off an alarm manually if they are under medical stress, which will then dial designated contact phone numbers. The fundamental problem with this system is that when medical emergencies happen to the user, they are often unconscious and unable to press an 'emergency alert button'. There is no product on the market which does not require manual activation of the alarm and monitors a user's vital signs smartly. This is the novel design goal of the work presented in this paper.

The reported device consists of a wrist strap and a finger glove. This allows the sensors to be mounted around the wrist and finger. A battery and a microcontroller, with built-in RF transceiver, are mounted within the wrist strap as well. In Section II we present the complete system overview. All the sensors are explained in Section III. The hardware details are in Section IV and the algorithms in Section V. The prototype and test results are discussed in Section VI. The paper ends with a discussion on future developments

## II. SYSTEM OVERVIEW

The system has been designed to take several inputs from a human subject to measure physiological parameters such as temperature and heart rate. Figure 1 shows the functional block diagram of the system hardware. The inputs from the sensors are processed and the results transmitted to a receiver unit, which is connected to a computer placed in the home, using Radio Frequency (RF) wireless technology. The receiver unit decodes and analyses the data. If it is inferred that the person is medically distressed, an alarm is generated. The design is modular which makes it rather easy and straight forward to add extra sensors for measuring and monitoring other parameters. The hardware blocks are explained in full details in a later section.

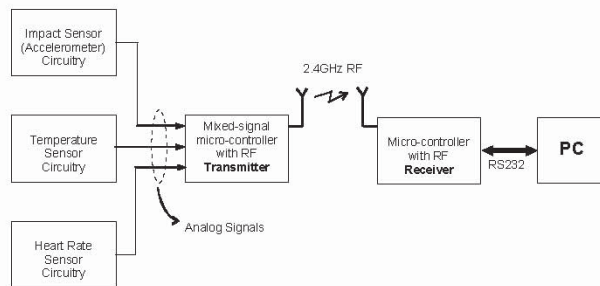

Fig. 1. Functional block diagram of the system hardware

## III. SENSORS AND INTERFACE

The system consists of three sensors- a temperature sensor, heart rate sensor, and an impact sensor. All the sensor circuitries used in the design generate analog voltages which are fed to the ADC (Analog-to-Digital) inputs of the micro-controller. The ADC inputs are time-multiplexed and sampled at different rates. The description of individual sensors follows.

### A. Temperature Sensor

The temperature measurement is done using a LM35 [7] precision integrated-circuit temperature sensor. It provides an accuracy of  $\pm 0.25^{\circ}\text{C}$  within the desired temperature measurement range of  $20\text{-}40^{\circ}\text{C}$ . It has a very low current drain of  $60\ \mu\text{A}$ . This sensor is mounted within the wrist strap, positioned in such a way that it is in contact with the skin, allowing it to measure the external temperature of the skin. From the skin temperature, the body temperature is estimated. Because an exact measurement of body temperature is not required, this method is suitable. Rather, relative changes are monitored within set thresholds, which set off the alarm. This allows the device to detect changes in body temperature that could indicate the patient is undergoing any of the following conditions: trauma, injury, heart attack, stroke, heat exhaustion, and burns [8]. The temperature sensor is sampled once every 3 seconds.

### B. Heart Rate Sensor

A custom heart rate sensor was designed to read the patient's beats per minute (bpm). The designed sensor is very small and inexpensive. The technique used to measure the heart rate is based on near-infrared (NIR) spectroscopy. NIR spectroscopy involves using light in the wavelength of  $700\text{-}900\text{nm}$  to measure blood volume. At these wavelengths most tissues do not absorb light – other than hemoglobin (which is what we are interested in). This allowed for designing a non-invasive and low cost method of measuring the pulse. A silicon phototransistor and a GaAs infrared emitting diode were used in the sensor, moulded into a flat side-facing package. The amount of light that was detected by the phototransistor varied with the patient's heart pulse, as the amount of absorbed IR light changed with the flow of blood, which is directly linked to the heart rate. This signal was then amplified, filtered, and sent to the microcontroller to be analyzed. The heart rate sensor was mounted in the finger glove as this position proved to give the best response.

### C. Impact Sensor

An ADXL311 accelerometer was used as an impact sensor. It provides a 2-axis response, measuring accelerations up to  $\pm 2g$ . It was fitted into the wrist strap. The accelerometer provides an analog voltage, the amplitude of which is directly proportional to acceleration. This signal was scaled down to bring it within the acceptable input range of the micro-controller, and then analyzed. Software algorithms were used to detect sharp impacts, while allowing slower movements, such as walking, to be ignored. The purpose of this sensor was to detect sudden impacts that could indicate the patient had fallen over.

## IV. HARDWARE DESIGN

The hardware was built in three separate blocks. A sensor card was designed to house the temperature sensor, accelerometer and the connections for the NIR emitter and detector. A separate analog card was designed for all the analog processing circuitry needed for the sensors, primarily for processing the heart rate signal. The temperature and acceleration output was fed directly to the micro-controller. The micro-controller was mounted on a separate card which also had the antenna connection. The cards were connected by ribbon cables within the wrist strap. Figure 2 shows the circuit schematics of the sensor units and Figure 3 shows the analog processing circuit for measuring heart beat rate.

### A. Lock-In Amplification for heart rate measurement

The micro-controller modulates the infra-red emitter signal at 1 KHz through a *npn* transistor (Figure 2). This is then mixed with the signal obtained from the IR sensors (back scattered light). This technique, known as Lock-In Amplification [9], involves phase sensitive detection.

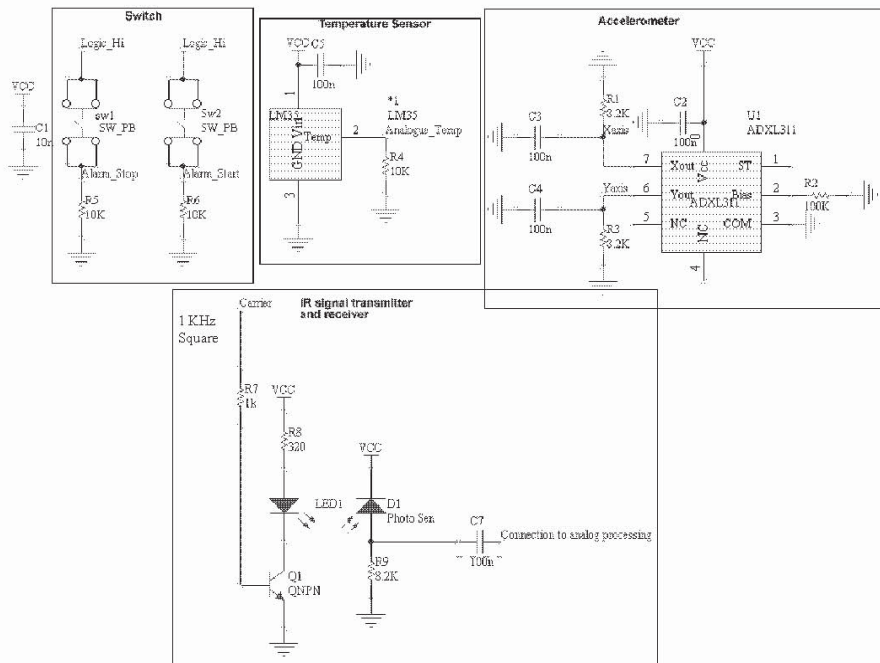

Fig. 2. Sensor Units

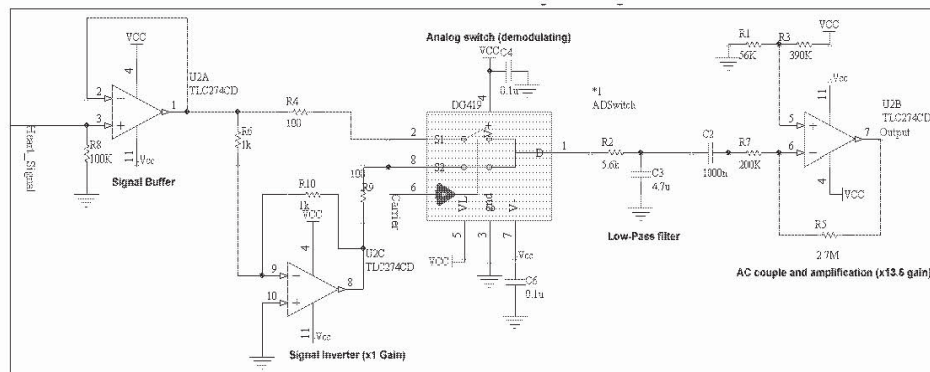

Fig. 3. Signal conditioning for Heart Rate Monitoring

The signal of interest (1-2 Hz) is moved into a much higher frequency band together with the noise that is picked up by the sensors. Demodulation is performed by an analog switch, which demodulates at the same frequency and in phase with the 1 KHz modulating signal. The resulting signal is then passed through a low-pass filter with a cut off frequency of 6Hz. This allows the signal of interest to pass through, while filtering out all noise that originated from the sensor. This is illustrated in figure 4.

### B. Controller Card

The controller used in the wrist strap unit (and also in the receiver unit) is a Nordic nREF24E1. This takes inputs from

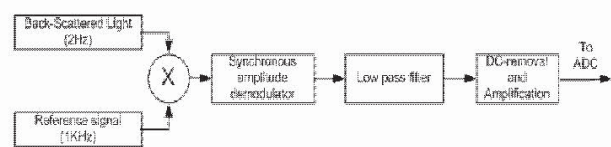

Fig. 4. Lock-In Amplification for heart rate measurement

the sensor circuits in the form of analog voltages. Each sensor has a dedicated ADC channel which is multiplexed by the microcontroller. Each sensor's signal is sampled at a predefined rate, through interrupt-driven algorithms. This microcontroller was chosen because of its small footprint (6mm x 6mm), low power consumption, and built-in

transceiver. The microcontroller is responsible for producing the carrier signal that modulates the IR emitting diode, which is used in demodulation too. It is powered by a 9V battery, which is regulated down to 5V. The controller card contains the microcontroller, crystal oscillator, RF antenna connection, and header pins which connect analog and digital ports to the other components of the unit.

### C. Receiver Unit

The hardware of the receiver unit is housed in a plastic box and consists of a nREF24E1 microcontroller, antenna, a 5V AC adaptor and serial interface port. The receiving unit is connected, via a RS232 serial port, to a personal computer (PC) and is constantly receiving information about the patient's medical status. A program, running on the PC, receives the packetized information from the serial port, decodes the packet and then displays this information on the PC monitor. The program offers several options to set thresholds of the allowable range of heart rate, skin temperature and impact sensor. When the readings from the patient move outside of the set range, an alarm is raised. The software can depict the change in data over time in a graphical plot. One receiver unit can be interfaced with multiple wrist units. In the software, one can tab through the information received from each wrist unit.

### D. Communication

Communication between the wrist units and the receiver unit is wireless, powered by the nREF24E1, and transmitted in the unlicensed 2.4GHz frequency band. Information is gathered every 3 seconds from the sensors and then encoded into a packet. Each packet is 6 bytes long, composed as shown in figure 5.

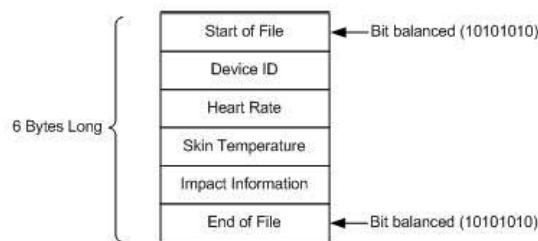

Fig. 5. Data packet composition

The heart rate included in the packet is in beats per minutes (bpm) which is calculated using the Heart Rate Algorithm explained in Section V. The temperature data is the result of the ADC conversion, done once every 3 seconds, and is decoded into degrees Celsius at the receiver unit. The impact information is the maximum output voltage of the accelerometer measured in the past 3 seconds. This is also the digital value obtained from the ADC conversion.

The data packet is sent by the nREF24E1 using a technology termed ShockBurst™. This allows data to be clocked into a FIFO buffer at a low data rate, and then transmitted all at once at a very high rate. This lowers power consumption by minimizing the amount of receiving and transmitting time. Data is transmitted by this method at 1Mbps. This also reduces the risk of a data collision with other wrist units, or devices operating in the same band.

## V. SOFTWARE AND ALGORITHMS

Several algorithms were implemented on the microcontroller. These algorithms take inputs from the sensors and process them into meaningful information.

### A. Heart Rate Algorithm

The heart rate signal is an oscillating signal of 1 to 2Hz. This is sampled by the microcontroller at 50Hz, and then averaged over 5 samples, which gives the algorithm an effective data input rate of 10 samples per second. This is stored in a buffer which is 32 bytes long. Once this buffer is full, the algorithm scans through each value in the buffer to compute the period of the signal (see figure 6). Since the signal is not sinusoidal, rather has distinct peaks corresponding to the contractions in the heart, the period is measured by marking transitions over the 25% mark. This is the most reliable part of the received signal. Since the sample time is known (0.1s), the number of samples between these 'transition points' is used to calculate the period and hence the frequency. The frequency is then multiplied by 60 to compute the heart rate (in bpm, beats per minute) of the patient.

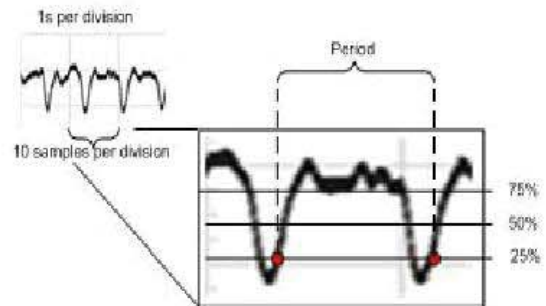

Fig. 6. Heart rate measurement algorithm

### B. Impact Algorithm

The signal received from the accelerometer is a DC voltage, the amplitude of which is directly related to the acceleration (62mV/g). This input is sampled at 10Hz, and stored in a buffer which is 10 bytes long. Every second, this buffer is scanned, and the maximum amplitude is recorded. At the receiver unit, this data is compared to recorded representative values for walking and jogging. This ensures that an alarm is set off only for very sharp, heavy impacts.

The reliability of impact detection was very good and the walking could easily be differentiated from a fall.

## VI. PROTOTYPE AND EXPERIMENTAL RESULTS

The Nordic micro-controller development board was used to build and test the prototype design. The analog processing circuitry and the sensors were assembled on PCBs which were placed within the wrist strap. Figure 7 shows the prototype hardware. The prototype was powered off a 9V battery. The RF transmission has been tested to operate successfully at 10 meters range through obstacles such as concrete walls. The receiver unit, without the casing, can be seen in figure 8.

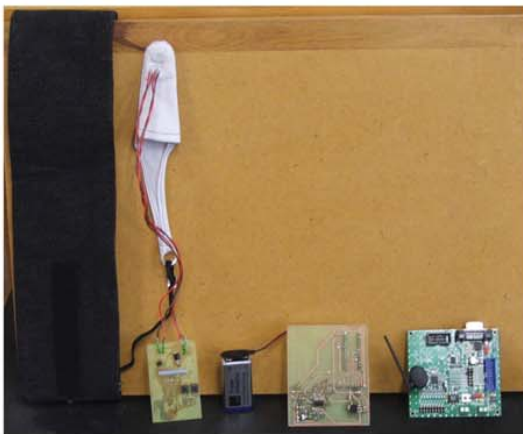

Fig. 7. Device prototype and finger glove



Fig. 8. Prototype receiver connected to a PC

### A. Heart Rate Sensor Test Results

A new heart rate is calculated every 3.2 seconds. The output of the sensor is a 200-400 mV p-p signal, riding a DC signal of 500mV. On human tests it is able to measure within  $\pm 2$  bpm of a rested patient (confirmed by measuring pulse

with thumb on carotid artery). Figure 9 shows a segment of a received heart rate signal.

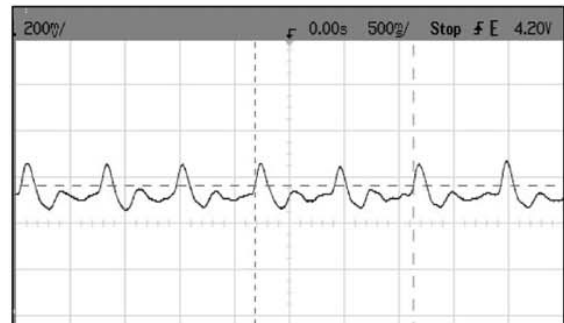

Fig. 9. Segment of a heart rate signal

### B. Impact Sensor Test results

The output of the accelerometer was tested with walking and simulated falling. The results showed the difference was simple to detect and proved the accuracy of the algorithm. Figure 10 shows the impact sensor output.

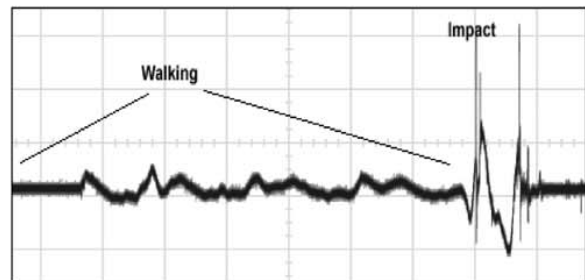

Fig. 10. Impact sensor output for walking and a fall

## VII. DISCUSSIONS AND FUTURE DEVELOPMENTS

In this paper we have presented the research, of applied nature, done to monitor physiological parameters such as skin temperature, heart rate and body impact. A prototype was successfully developed and tested to establish the proof of concept. The algorithms were tested and found to be accurate and reliable. The novel aspect of the design is its low cost and detection of medical distress which does not necessitate pressing any panic button. This is an enormous improvement over existing commercial products.

An important aspect of the design was miniaturization, so that the system was as non-intrusive as possible to the wearer. This was achieved by the use of surface-mounted devices on the PCBs designed. Low power operational amplifiers were used to minimize battery consumption. The price of the unit currently is \$70. The major costs come from the use of precision components, accelerometer and temperature sensor.

With some modification, the system can be made available commercially. Future improvements will focus on the use of

# Explore Litigation Insights

Docket Alarm provides insights to develop a more informed litigation strategy and the peace of mind of knowing you're on top of things.

## Real-Time Litigation Alerts



Keep your litigation team up-to-date with **real-time alerts** and advanced team management tools built for the enterprise, all while greatly reducing PACER spend.

Our comprehensive service means we can handle Federal, State, and Administrative courts across the country.

## Advanced Docket Research



With over 230 million records, Docket Alarm's cloud-native docket research platform finds what other services can't. Coverage includes Federal, State, plus PTAB, TTAB, ITC and NLRB decisions, all in one place.

Identify arguments that have been successful in the past with full text, pinpoint searching. Link to case law cited within any court document via Fastcase.

## Analytics At Your Fingertips



Learn what happened the last time a particular judge, opposing counsel or company faced cases similar to yours.

Advanced out-of-the-box PTAB and TTAB analytics are always at your fingertips.

## API

Docket Alarm offers a powerful API (application programming interface) to developers that want to integrate case filings into their apps.

## LAW FIRMS

Build custom dashboards for your attorneys and clients with live data direct from the court.

Automate many repetitive legal tasks like conflict checks, document management, and marketing.

## FINANCIAL INSTITUTIONS

Litigation and bankruptcy checks for companies and debtors.

## E-DISCOVERY AND LEGAL VENDORS

Sync your system to PACER to automate legal marketing.