



US005297548A

United States Patent [19]
Pologe

[11] **Patent Number:** 5,297,548
[45] **Date of Patent:** Mar. 29, 1994

- [54] **ARTERIAL BLOOD MONITORING PROBE**
- [75] **Inventor:** Jonas A. Pologe, Boulder, Colo.
- [73] **Assignee:** Ohmeda Inc., Murray Hill, N.J.
- [21] **Appl. No.:** 45,962
- [22] **Filed:** Apr. 12, 1993

5,137,023 8/1992 Mendelson et al. 128/633

FOREIGN PATENT DOCUMENTS

- 0303502 2/1989 European Pat. Off. .
- 9004353 5/1990 PCT Int'l Appl. .
- 911136 8/1991 PCT Int'l Appl. .

Primary Examiner—Angela D. Sykes
Attorney, Agent, or Firm—Roger M. Rathbun; Larry R. Cassett; James M. Graziano

Related U.S. Application Data

- [63] Continuation-in-part of Ser. No. 832,551, Feb. 7, 1992.
- [51] **Int. Cl.⁵** **A61B 5/00**
- [52] **U.S. Cl.** **128/633; 128/665;**
356/41
- [58] **Field of Search** 128/633-634,
128/664-667; 356/39-41

[57] **ABSTRACT**

This arterial blood monitoring system takes advantage of the basic statistical property that arterial blood contains a plurality of dominant absorbers, whose measured light absorption spectra appear as a constant over a short interval of time. By measuring the transmitted light as it varies with arterial pulsation at selected wavelengths of light, over a common light path, the relative amount of these dominant absorbers in the arterial blood can noninvasively be determined. To ensure the common light path, a sandwich construction light detector is used.

[56] **References Cited**

U.S. PATENT DOCUMENTS

- 4,223,680 9/1980 Jobsis 128/633
- 4,824,242 4/1989 Frick et al. 128/666 X
- 4,867,165 9/1989 Noller et al. 128/666 X
- 5,078,136 1/1992 Stone et al. 128/666 X
- 5,127,406 7/1992 Yamaguchi 128/633

10 Claims, 4 Drawing Sheets

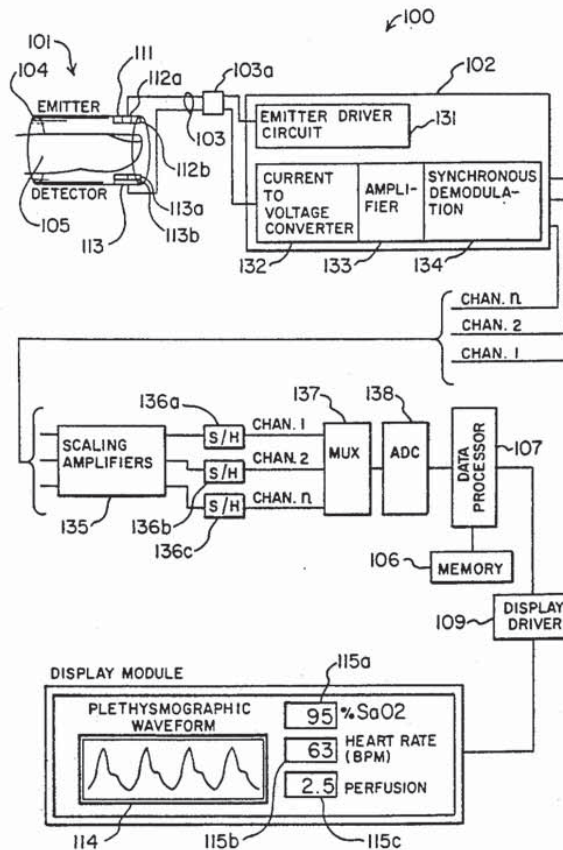

Apple Inc.
APL1019

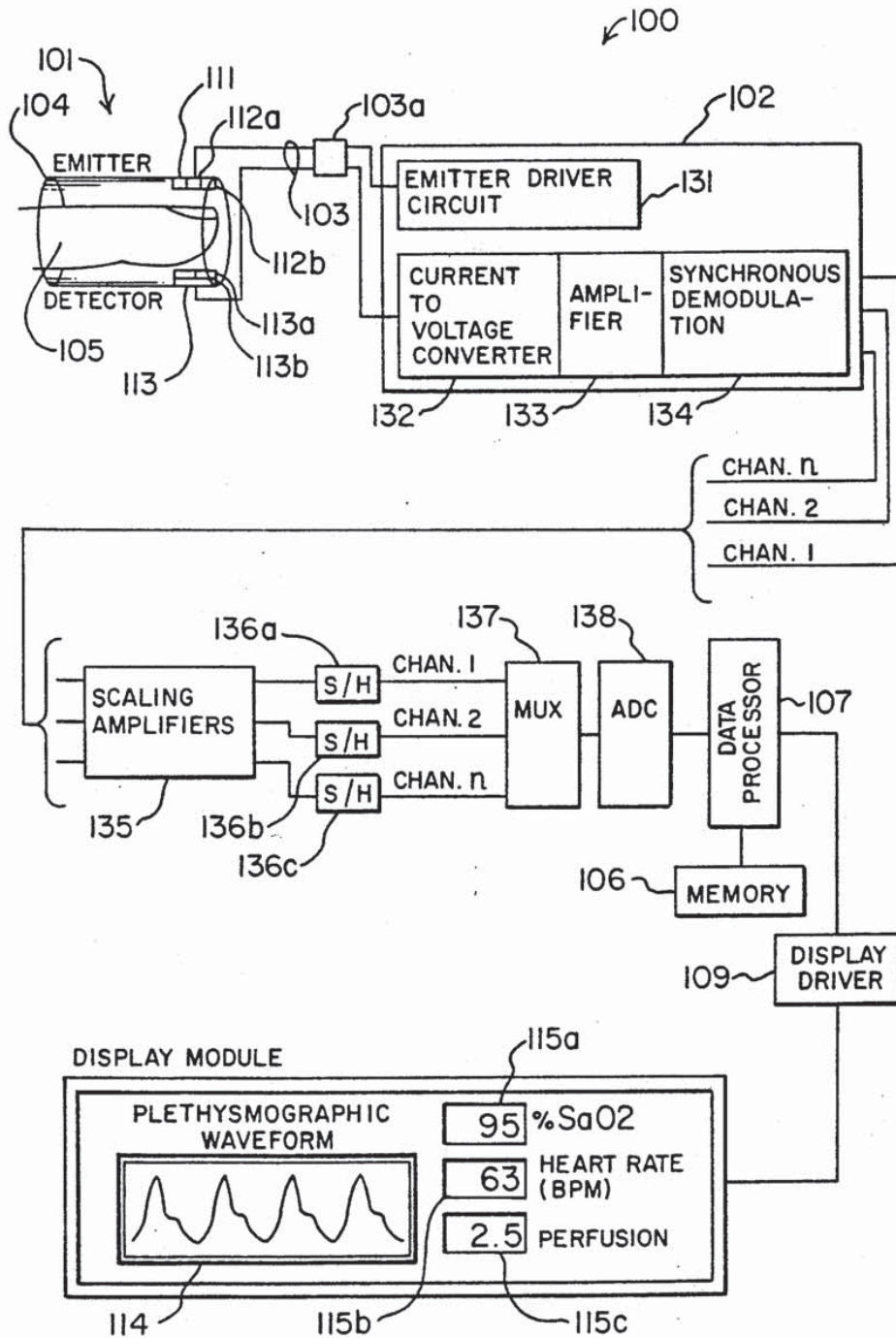

FIG. 1.

FIG. 2.

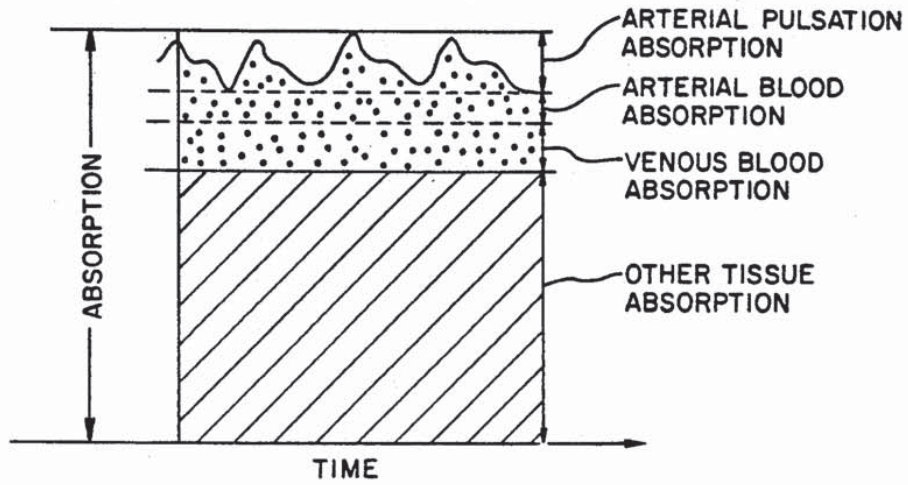
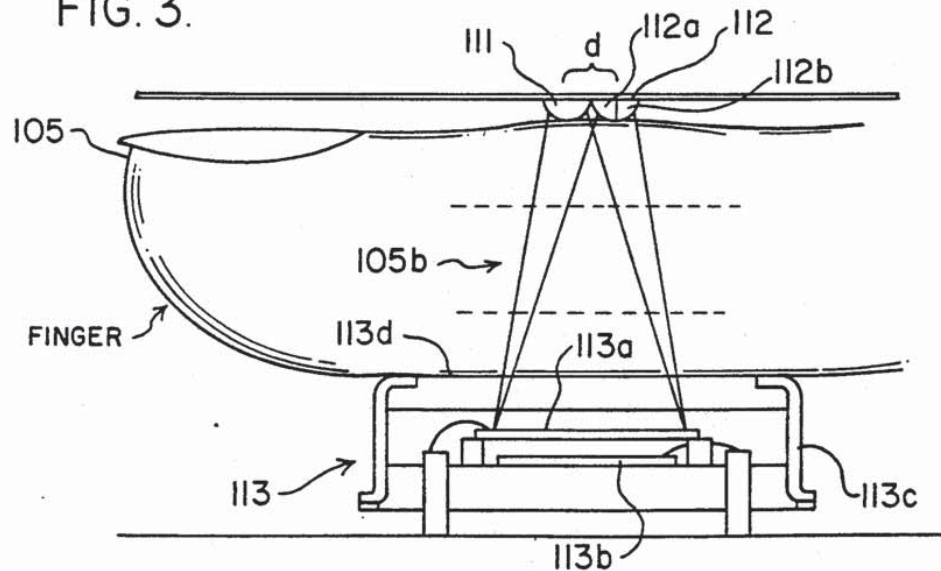

FIG. 3.



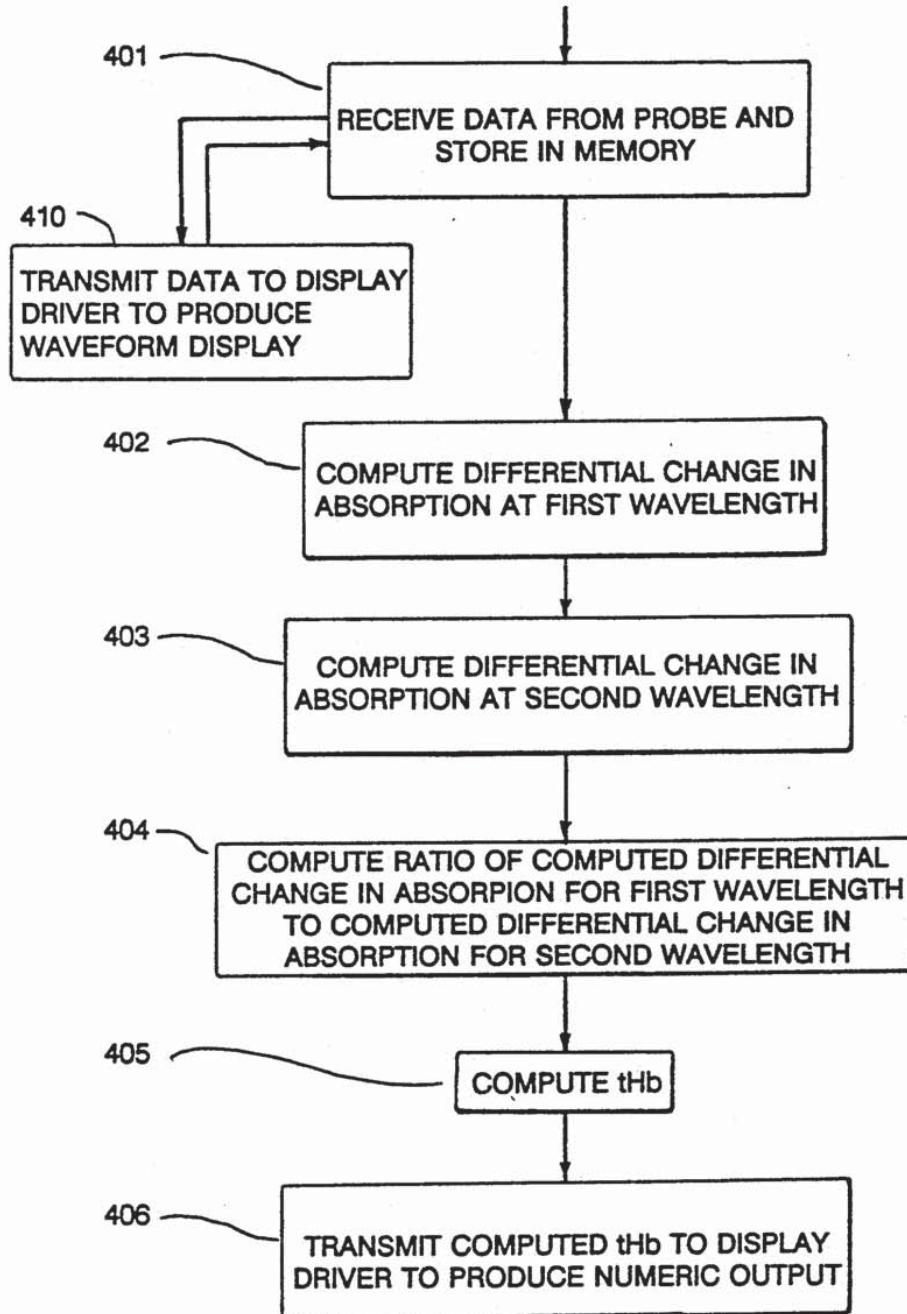

FIGURE 4

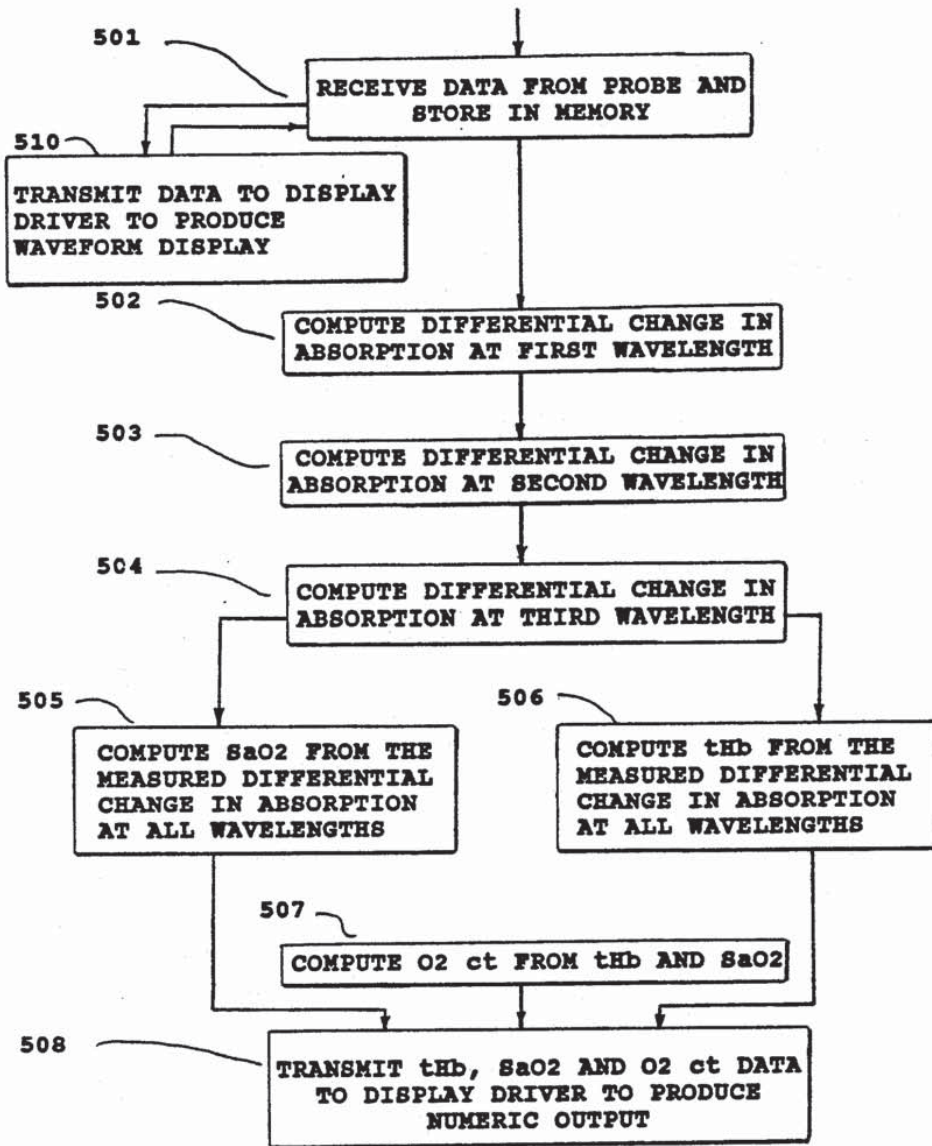

FIGURE 5

Explore Litigation Insights

Docket Alarm provides insights to develop a more informed litigation strategy and the peace of mind of knowing you're on top of things.

Real-Time Litigation Alerts



Keep your litigation team up-to-date with **real-time alerts** and advanced team management tools built for the enterprise, all while greatly reducing PACER spend.

Our comprehensive service means we can handle Federal, State, and Administrative courts across the country.

Advanced Docket Research



With over 230 million records, Docket Alarm's cloud-native docket research platform finds what other services can't. Coverage includes Federal, State, plus PTAB, TTAB, ITC and NLRB decisions, all in one place.

Identify arguments that have been successful in the past with full text, pinpoint searching. Link to case law cited within any court document via Fastcase.

Analytics At Your Fingertips



Learn what happened the last time a particular judge, opposing counsel or company faced cases similar to yours.

Advanced out-of-the-box PTAB and TTAB analytics are always at your fingertips.

API

Docket Alarm offers a powerful API (application programming interface) to developers that want to integrate case filings into their apps.

LAW FIRMS

Build custom dashboards for your attorneys and clients with live data direct from the court.

Automate many repetitive legal tasks like conflict checks, document management, and marketing.

FINANCIAL INSTITUTIONS

Litigation and bankruptcy checks for companies and debtors.

E-DISCOVERY AND LEGAL VENDORS

Sync your system to PACER to automate legal marketing.