

United States Patent [19]

[11] Patent Number: 4,830,014

Goodman et al.

[45] Date of Patent: May 16, 1989

- [54] **SENSOR HAVING CUTANEOUS CONFORMANCE**
- [75] Inventors: **David E. Goodman, San Francisco; James E. Corenman, Menlo Park; William New, Jr., Woodside; Mark Yelderman, Menlo Park, all of Calif.**
- [73] Assignee: **Nellcor Incorporated, Hayward, Calif.**
- [21] Appl. No.: **70,619**
- [22] Filed: **Jul. 7, 1987**

2262952 10/1975 France .

OTHER PUBLICATIONS

Cohen, Arnon, "Photoelectric Determination of the Relative Oxygenation of Blood", Carnegie-Mellon University, Ph.D. Thesis, 1969, (pp. 57-77).

Primary Examiner—Edward M. Coven
Attorney, Agent, or Firm—Thomas L. Giannetti; Jeffrey H. Ingerman

Related U.S. Application Data

- [63] Continuation of Ser. No. 873,129, Jun. 11, 1986, abandoned, which is a continuation of Ser. No. 539,865, Oct. 7, 1983, abandoned, which is a continuation-in-part of Ser. No. 493,442, May 11, 1983, abandoned.

- [51] Int. Cl.⁴ **A61B 5/02**
- [52] U.S. Cl. **128/665; 128/666**
- [58] Field of Search **128/633, 637, 640, 644, 128/665, 667, 664, 689, 690, 691**

[57] **ABSTRACT**

A sensor for trans-illumination of a blood perfused portion of flesh to measure light extinction during trans-illumination is disclosed. The sensor is preferably mounted on a fingertip but any digit or blood perfused portion of flesh will work. The sensor includes a first end for disposition on one side of the trans-illuminated flesh and a second end for disposition on the opposite and opposed side of the trans-illuminated flesh. A light source is mounted to the first side and a photo-sensor is mounted to the second side. If an elongated flexible strip is used, it is provided with adhesive and is suitably windowed that light is allowed to take an optical path through the finger. If no flexible strip is used, the two ends are aligned and secured to the flesh such that the light emitted takes an optical path through the finger. When the adhesive fastener is used, the effect of the light source and photo-detector substrates being integrated into the adhesive fastener is that they become, in effect, a part of the skin. The resulting device is resistant to accidental removal and avoids constriction of blood vessels. Most importantly, the low mass of the sensor itself and its conformance to, so as to effectively become a part of, the skin, prevents relative motion between the light source and sensor and the perfused flesh. This eliminates the common interference associated with the operation of conventional plethysmographs and oximeters.

[56] **References Cited**

U.S. PATENT DOCUMENTS

- 3,167,658 1/1965 Richter 128/666 X
- 3,599,629 8/1971 Gordy 128/640
- 3,602,213 8/1971 Howell et al. 128/2.05 F
- 3,769,974 11/1973 Smart et al. 128/666
- 3,807,388 4/1974 Orn et al. 128/690
- 4,013,067 3/1977 Kresse et al. 128/660
- 4,091,803 5/1978 Pinda 128/666
- 4,305,401 12/1981 Reissmueller et al. 128/690
- 4,350,165 9/1982 Striese 128/640
- 4,370,984 2/1983 Cartmell 128/640
- 4,380,240 4/1983 Jöbssis et al. 128/633
- 4,406,289 9/1983 Wesseling et al. 128/690

FOREIGN PATENT DOCUMENTS

- 671279 10/1963 Canada 128/690
- 0019478 11/1980 European Pat. Off. .

2 Claims, 4 Drawing Sheets

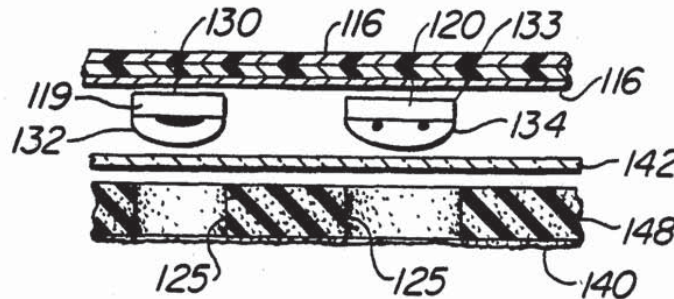

Apple Inc.
APL1007

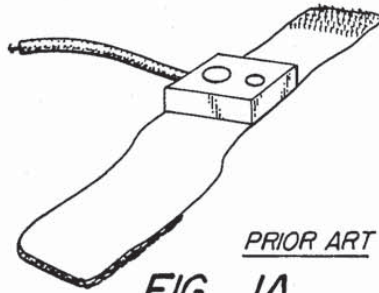

PRIOR ART

FIG. 1A.



PRIOR ART

FIG. 1B.

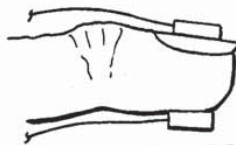

PRIOR ART

FIG. 1C.

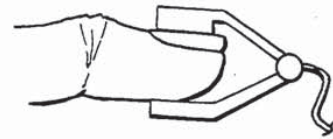

PRIOR ART

FIG. 1D.

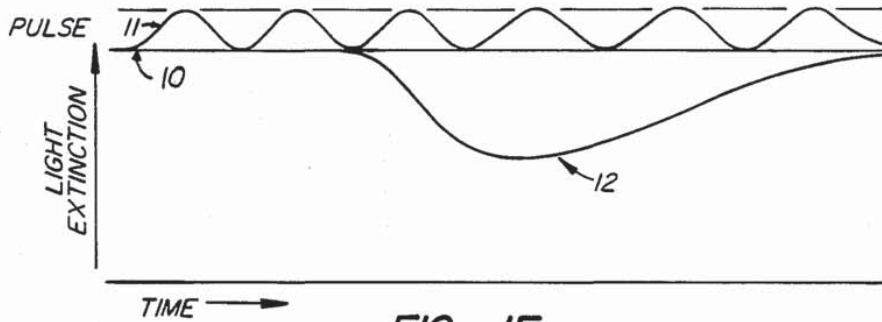

FIG. 1E.

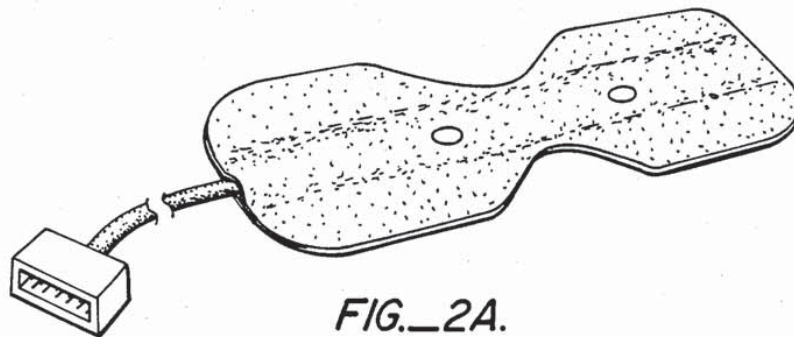
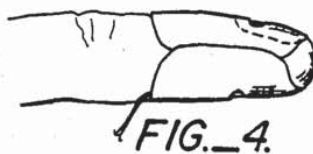
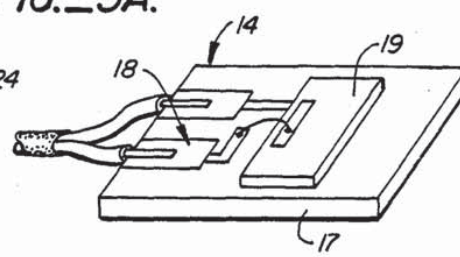
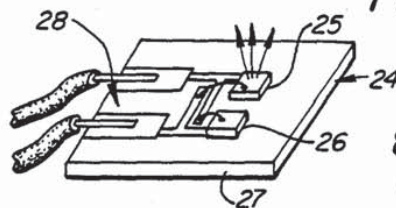
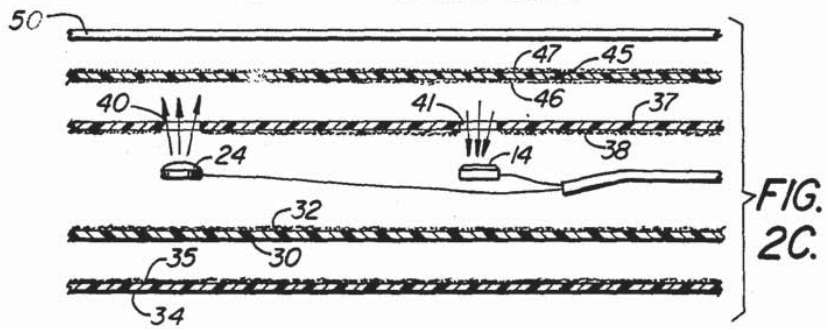
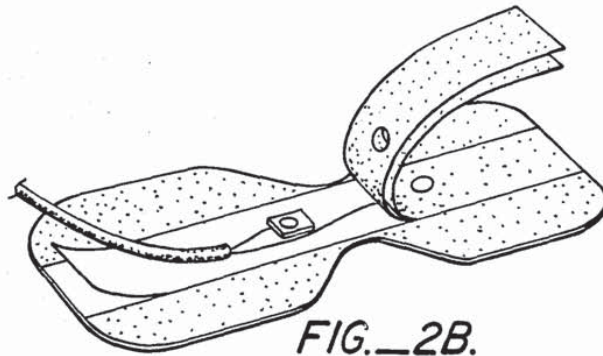
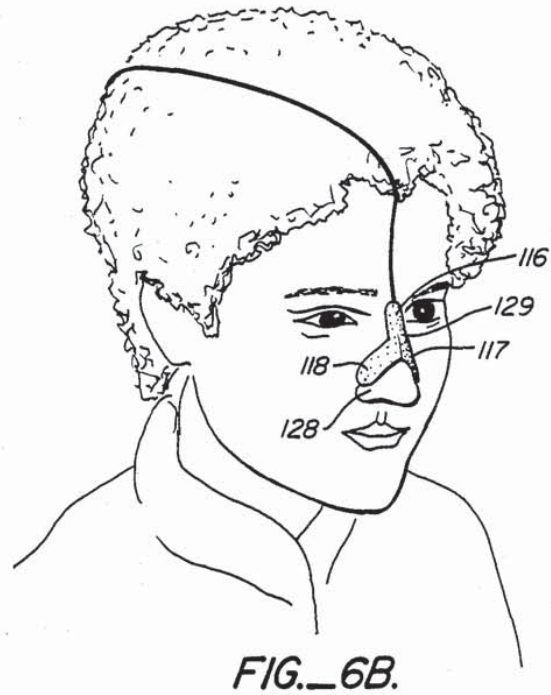
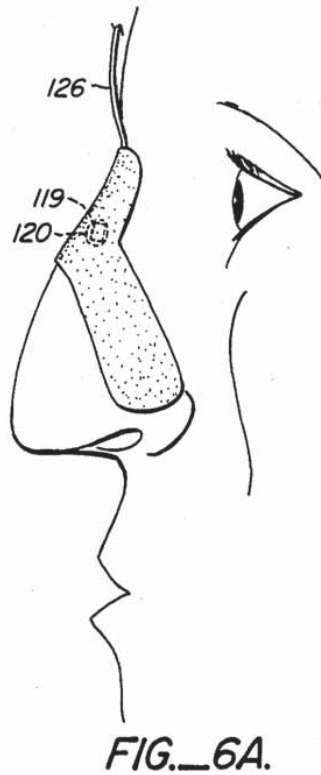
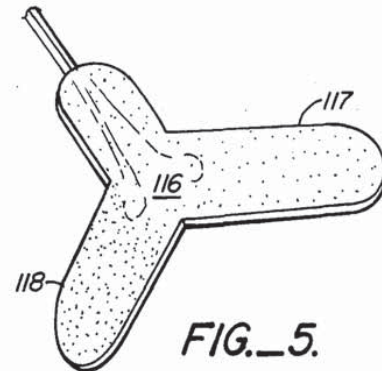
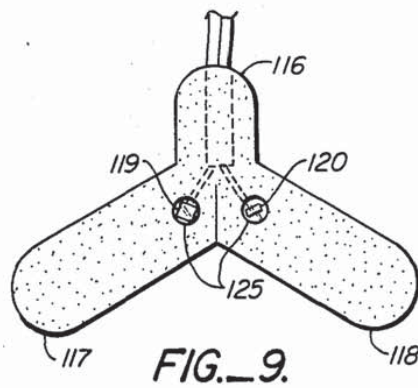
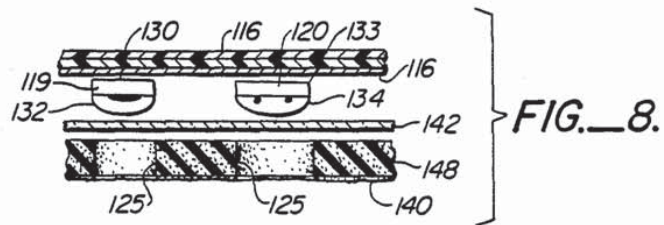
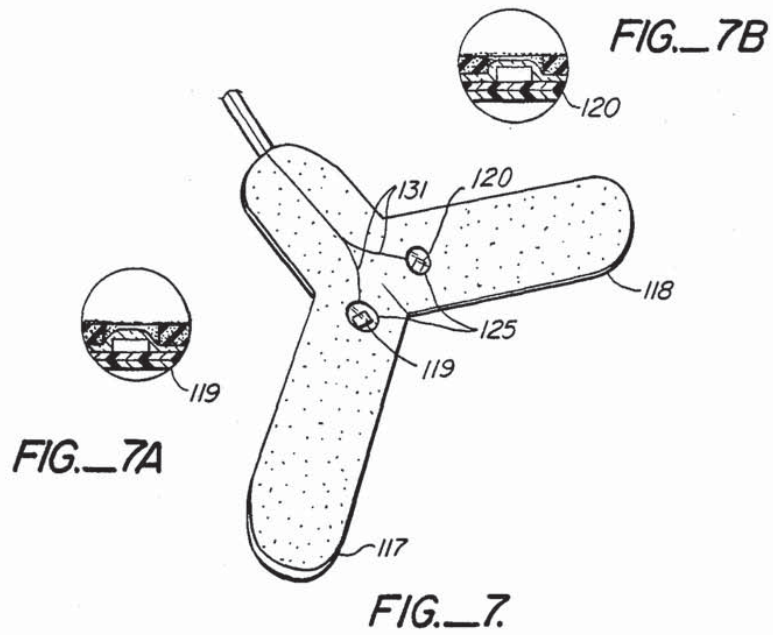

FIG. 2A.







Explore Litigation Insights

Docket Alarm provides insights to develop a more informed litigation strategy and the peace of mind of knowing you're on top of things.

Real-Time Litigation Alerts



Keep your litigation team up-to-date with **real-time alerts** and advanced team management tools built for the enterprise, all while greatly reducing PACER spend.

Our comprehensive service means we can handle Federal, State, and Administrative courts across the country.

Advanced Docket Research



With over 230 million records, Docket Alarm's cloud-native docket research platform finds what other services can't. Coverage includes Federal, State, plus PTAB, TTAB, ITC and NLRB decisions, all in one place.

Identify arguments that have been successful in the past with full text, pinpoint searching. Link to case law cited within any court document via Fastcase.

Analytics At Your Fingertips



Learn what happened the last time a particular judge, opposing counsel or company faced cases similar to yours.

Advanced out-of-the-box PTAB and TTAB analytics are always at your fingertips.

API

Docket Alarm offers a powerful API (application programming interface) to developers that want to integrate case filings into their apps.

LAW FIRMS

Build custom dashboards for your attorneys and clients with live data direct from the court.

Automate many repetitive legal tasks like conflict checks, document management, and marketing.

FINANCIAL INSTITUTIONS

Litigation and bankruptcy checks for companies and debtors.

E-DISCOVERY AND LEGAL VENDORS

Sync your system to PACER to automate legal marketing.