

(19) World Intellectual Property Organization
International Bureau



(43) International Publication Date
21 June 2001 (21.06.2001)

PCT

(10) International Publication Number
WO 01/45233 A1

(51) International Patent Classification⁷: **H02K 5/24**

(74) Agent: **SHURTZ, Steven, P.**; Brinks Hofer Gilson & Li-one, P.O. Box 10087, Chicago, IL 60610 (US).

(21) International Application Number: PCT/US00/34078

(81) Designated States (*national*): AE, AG, AL, AM, AT, AU, AZ, BA, BB, BG, BR, BY, BZ, CA, CH, CN, CR, CU, CZ, DE, DK, DM, DZ, EE, ES, FI, GB, GD, GE, GH, GM, HR, HU, ID, IL, IN, IS, JP, KE, KG, KP, KR, KZ, LC, LK, LR, LS, LT, LU, LV, MA, MD, MG, MK, MN, MW, MX, MZ, NO, NZ, PL, PT, RO, RU, SD, SE, SG, SI, SK, SL, TJ, TM, TR, TT, TZ, UA, UG, UZ, VN, YU, ZA, ZW.

(22) International Filing Date:
15 December 2000 (15.12.2000)

(25) Filing Language: English

(26) Publication Language: English

(30) Priority Data:
60/172,287 17 December 1999 (17.12.1999) US
60/171,817 21 December 1999 (21.12.1999) US

(84) Designated States (*regional*): ARIPO patent (GH, GM, KE, LS, MW, MZ, SD, SL, SZ, TZ, UG, ZW), Eurasian patent (AM, AZ, BY, KG, KZ, MD, RU, TJ, TM), European patent (AT, BE, CH, CY, DE, DK, ES, FI, FR, GB, GR, IE, IT, LU, MC, NL, PT, SE, TR), OAPI patent (BF, BJ, CF, CG, CI, CM, GA, GN, GW, ML, MR, NE, SN, TD, TG).

(71) Applicant: **ENCAP MOTOR CORPORATION**
[US/US]; 540 Delancy Street, Suite 301, San Francisco, CA 94107 (US).

Published:

- With international search report.
- Before the expiration of the time limit for amending the claims and to be republished in the event of receipt of amendments.

(72) Inventors: **LIEU, Dennis, K.**; 1036 Wickham Drive, Moraga, CA 94556 (US). **NEAL, Griffith, D.**; 1330 Bay Street, Alameda, CA 94501 (US).

[Continued on next page]

(54) Title: SPINDLE MOTOR WITH ENCAPSULATED STATOR AND METHOD OF MAKING SAME

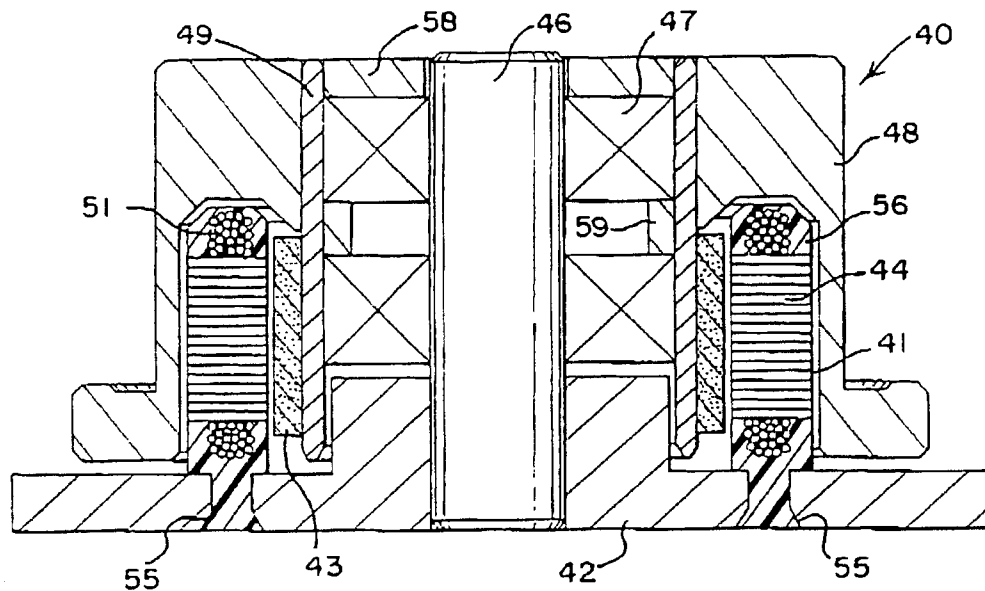

(57) Abstract: A spindle motor (20) comprises a baseplate (22), a shaft (26) supported by said baseplate (22), a stator assembly (21) having windings (31), the stator (21) being rigidly attached to said baseplate (22), injection molded thermoplastic material (36) encapsulating said windings (31), and a hub (28) supported on said shaft (26), said hub (28) having a magnet (23) connected thereto in operable proximity to the stator assembly (21). In one embodiment, a stator (71) is cordless. In other embodiments, the stator (21) has a core (24) and the core is substantially encapsulated by the thermoplastic material (36). In preferred embodiments, the



WO 01/45233 A1



For two-letter codes and other abbreviations, refer to the "Guidance Notes on Codes and Abbreviations" appearing at the beginning of each regular issue of the PCT Gazette.

SPINDLE MOTOR WITH ENCAPSULATED STATOR AND METHOD OF MAKING SAME

REFERENCE TO EARLIER FILED APPLICATION.

5 The present application claims the benefit of the filing date under 35
U.S.C. §119(e) of provisional U.S. Patent Application Serial No. 60/172,287,
filed December 17, 1999, and of provisional U.S. Patent Application Serial No.
60/171,817, filed December 21, 1999, both of which are hereby incorporated
by reference.

FIELD OF THE INVENTION

10 The present invention relates to spindle motors. More particularly the
invention relates to spindle motors with an encapsulated stator and methods
of making the same, and hard drives utilizing the same.

BACKGROUND OF THE INVENTION

15 Computers commonly use disc drives for memory storage purposes.
Disc drives include a stack of one or more magnetic discs that rotate and are
accessed using a head or read-write transducer. Typically, a high-speed
motor such as a spindle motor is used to rotate the discs.

20 An example of a conventional spindle motor 1 is shown in FIG. 1. The
motor 1 includes a baseplate 2 which is usually made from machined
aluminum, a stator core 4, a shaft 6, bearings 7 and a disc support member 8,
also referred to as a hub. A magnet 3 is attached to the disc support
member or hub 8. The hub 8 may be made of steel so that it acts as a flux
return ring. The stator core 4 is secured to the baseplate 2 using a support
member 5. One end of the shaft 6 is inserted into the baseplate 2 and the
25 other end of the shaft 6 supports bearings 7, which are also attached to the
hub 8. A flexible electrical cable 9 may be supported on the baseplate 2.
Wires 12 from the cable exit through holes 15 in the baseplate. The flexible
cable 9 is also used to seal the baseplate so that particulate material is not
expelled from the motor 1. The wires 12 carry electric current to the wire
30 windings 11 wrapped around poles formed on the core 4. Mounting holes 14

on the baseplate are used to secure the motor to the baseplate of a housing for a hard disk drive or other electrical device. The hub 8 includes holes 13 that are used to attach the media discs (not shown) to the hub 8.

Each of these parts must be fixed at predefined tolerances with respect to one another. Accuracy in these tolerances can significantly enhance motor performance.

In operation, the disc stack is placed upon the hub. The stator windings 11 are selectively energized and interact with the permanent magnet 3 to cause a defined rotation of the hub. As hub 8 rotates, the head engages in reading or writing activities baseplated upon instructions from the CPU in the computer.

Manufacturers of disc drives are constantly seeking to improve the speed with which data can be accessed. To an extent, this speed depends upon the speed of the spindle motor, as existing magneto-resistive head technology is capable of accessing data at a rate greater than the speed offered by the highest speed spindle motor currently in production. The speed of the spindle motor is dependent upon the dimensional consistency or tolerances between the various components of the motor and the rigidity of the parts. Greater dimensional consistency between components and rigidity of the components leads to a smaller gap between the stator 4 and the magnet 3, producing more force, which provides more torque and enables faster acceleration and higher rotational speeds. In the design shown, the gap between the stator 4 and magnet 3 is located near the outside diameter of the hub 8. Thus the magnet 3 is attached to the most flexible part of the hub, making the spindle vulnerable to vibration caused by misalignment of the motor. One drawback of conventional spindle motors is that a number of separate parts are required to fix motor components to one another. This can lead to stack up tolerances which reduce the overall dimensional consistency between the components. Stack up tolerances refers to the sum of the variation of all the tolerances of all the parts, as well as the overall tolerance that relates to the alignment of the parts relative to one another.

Another drawback to the conventional design is the cost of the machined baseplate 2. Unfortunately, die-casting or forging does not produce baseplates with sufficient precision. Therefore quality baseplates are made by machining the necessary surfaces and tolerances. The flexible cable 9 also adds to the cost. Steel hubs 8 are expensive and difficult to machine. Aluminum hubs 8 are less expensive, but still must be extensively machined in the bearing area. The stator 4 is a major source of acoustic noise. Also, the stator assembly is difficult to clean, so that particulates are not emitted from the motor.

In an effort to enable increased motor speed, some hard disc manufacturers have turned to the use of hydrodynamic bearings. These hydrodynamic bearings, however, have different aspect ratios from conventional bearings. An example of a different aspect ratio may be found in a cylindrical hydrodynamic bearing in which the length of the bearing is greater than it's diameter. This results in more susceptibility to problems induced by differing coefficients of thermal expansion than other metals used in existing spindle motors, making it difficult to maintain dimensional consistency over the operating temperature that the drive sees between the hydrodynamic bearings and other metal parts of the motor. Hydrodynamic bearings have less stiffness than conventional ball bearings so they are more susceptible to imprecise rotation when exposed to vibrations or shock.

An important characteristic of a hard drive is the amount of information that can be stored on a disc. One method to store more information on a disc is to place data tracks more closely together. Presently this spacing between portions of information is limited due to vibrations occurring during the operation of the motor. These vibrations can be caused when the stator windings are energized, which results in vibrations of a particular frequency. These vibrations also occur from harmonic oscillations in the hub and discs during rotation, caused primarily by non-uniform size media discs.

An important factor in motor design is the lowering of the operating temperature of the motor. Increased motor temperature affects the electrical efficiency of the motor and bearing life. As temperature increases, resistive

Explore Litigation Insights

Docket Alarm provides insights to develop a more informed litigation strategy and the peace of mind of knowing you're on top of things.

Real-Time Litigation Alerts



Keep your litigation team up-to-date with **real-time alerts** and advanced team management tools built for the enterprise, all while greatly reducing PACER spend.

Our comprehensive service means we can handle Federal, State, and Administrative courts across the country.

Advanced Docket Research



With over 230 million records, Docket Alarm's cloud-native docket research platform finds what other services can't. Coverage includes Federal, State, plus PTAB, TTAB, ITC and NLRB decisions, all in one place.

Identify arguments that have been successful in the past with full text, pinpoint searching. Link to case law cited within any court document via Fastcase.

Analytics At Your Fingertips



Learn what happened the last time a particular judge, opposing counsel or company faced cases similar to yours.

Advanced out-of-the-box PTAB and TTAB analytics are always at your fingertips.

API

Docket Alarm offers a powerful API (application programming interface) to developers that want to integrate case filings into their apps.

LAW FIRMS

Build custom dashboards for your attorneys and clients with live data direct from the court.

Automate many repetitive legal tasks like conflict checks, document management, and marketing.

FINANCIAL INSTITUTIONS

Litigation and bankruptcy checks for companies and debtors.

E-DISCOVERY AND LEGAL VENDORS

Sync your system to PACER to automate legal marketing.