



US005672972A

# United States Patent [19]

[11] Patent Number: **5,672,972**

McCoy et al.

[45] Date of Patent: **Sep. 30, 1997**

[54] **DIAGNOSTIC SYSTEM FOR A CAPACITOR DISCHARGE IGNITION SYSTEM**

5,208,540	5/1993	Hoeflich	324/388
5,216,369	6/1993	Toyama	324/388
5,237,279	8/1993	Shimasaki et al.	324/391

[75] Inventors: **Steven R. McCoy**, Washington; **Horst Scheel**, Peoria, both of Ill.

### FOREIGN PATENT DOCUMENTS

0 389 775	10/1990	European Pat. Off.
2 493 414	5/1982	France
WO 88/01690	3/1988	WIPO

[73] Assignee: **Caterpillar Inc.**, Peoria, Ill.

*Primary Examiner*—Maura K. Regan

[21] Appl. No.: **946,491**

*Attorney, Agent, or Firm*—Kirk A. Vander Leest; R. Carl Wilbur

[22] PCT Filed: **May 27, 1992**

[86] PCT No.: **PCT/US92/04515**

### [57] ABSTRACT

§ 371 Date: **Nov. 9, 1992**

An apparatus is provided for monitoring ignition in individual cylinders of a multi-cylinder engine of the type having an ignition system which includes a separate transformer for each cylinder. Each transformer has primary and secondary coils. The secondary coil is connected in series with a spark gap in an associated one of the cylinders. The ignition system further includes selector switches for receiving cylinder select signals and responsively connecting respective transformer primary coils. The current flows through the primary coil resulting in a voltage potential across an associated spark gap which normally increases to a magnitude sufficient to cause a spark across the spark gap. A first circuit receives the cylinder select signals, senses time delay between the reception of a cylinder select signal and sparking in a respective cylinder and responsively produces a delay signal indicative of the sensed time delay. A diagnostics controller receives the delay signal, compares the delay signal to a plurality of preselected thresholds and responsively produces a status signal indicating the status of ignition in a respective cylinder.

§ 102(e) Date: **Nov. 9, 1992**

[87] PCT Pub. No.: **WO92/21876**

PCT Pub. Date: **Oct. 12, 1992**

[51] Int. Cl.<sup>6</sup> ..... **F02P 5/145; F02P 17/00**

[52] U.S. Cl. .... **324/393; 123/605; 324/388; 324/391**

[58] Field of Search ..... **324/380, 388, 324/391, 393, 399, 402; 73/116, 117.3; 123/605**

### [56] References Cited

#### U.S. PATENT DOCUMENTS

4,312,043	1/1982	Frank et al.	324/391
4,413,508	11/1983	Kamamura et al.	324/391
5,019,779	5/1991	Ookawa	324/388
5,060,623	10/1991	McCoy	123/605
5,156,127	10/1992	Ghaem	324/391

**15 Claims, 10 Drawing Sheets**

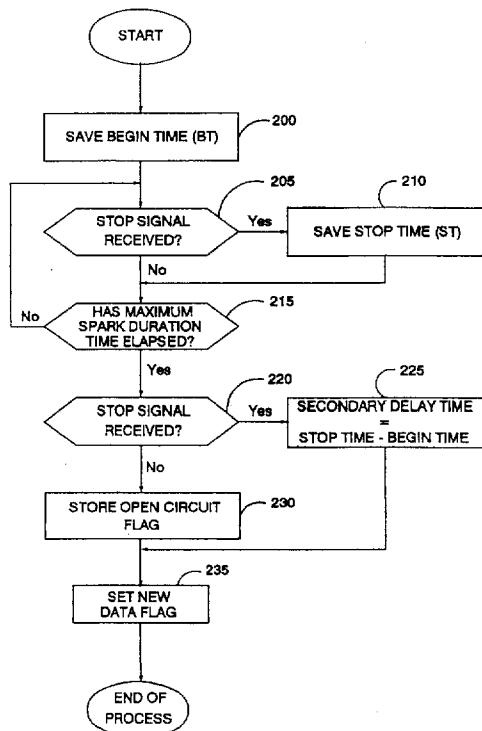

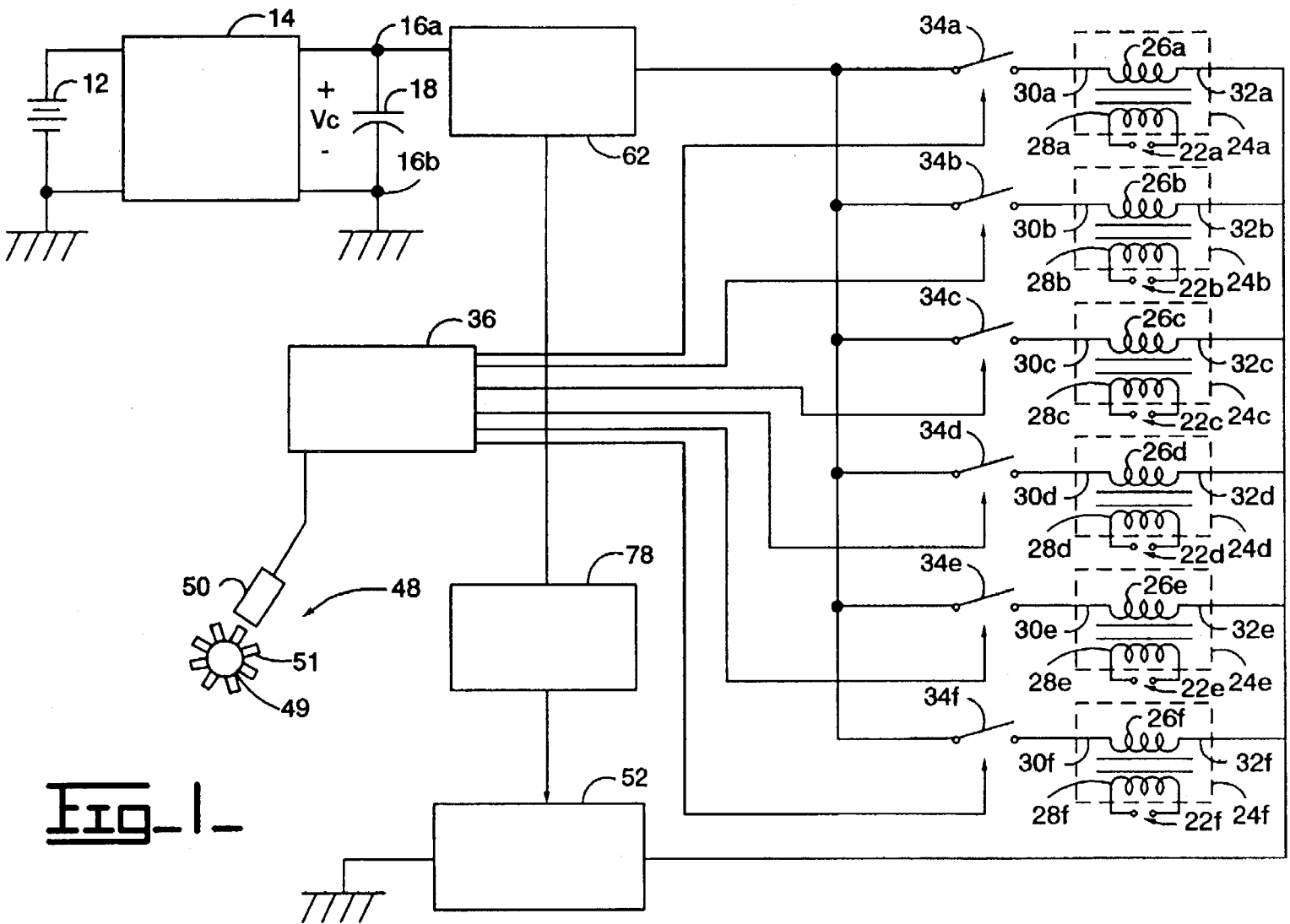

Fig. 1

10

FIG. 2.

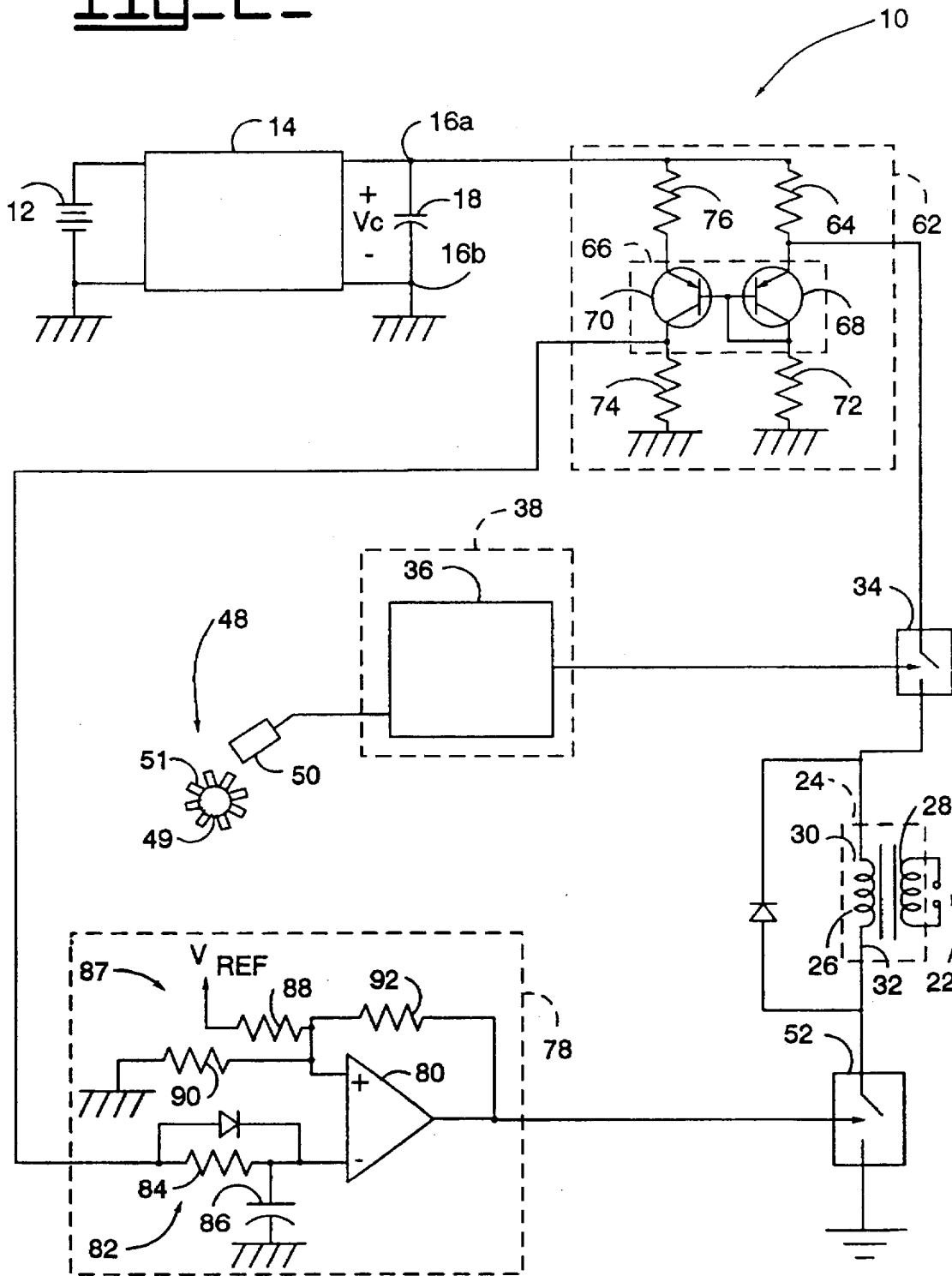



Fig. 4.

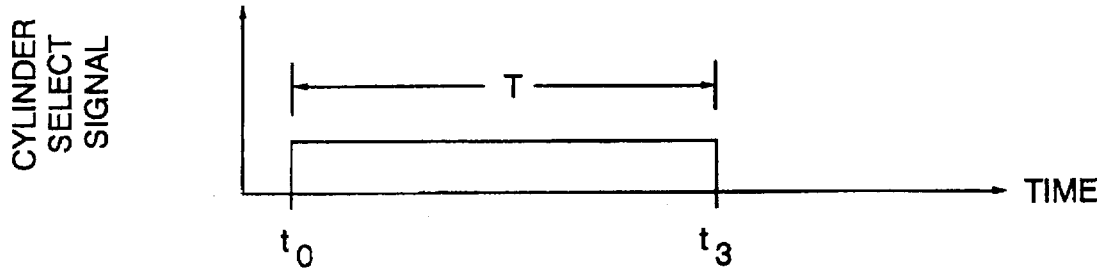

Fig. 5.

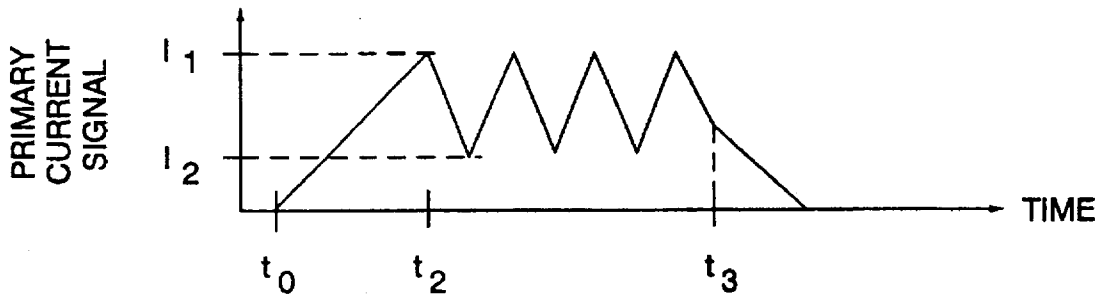
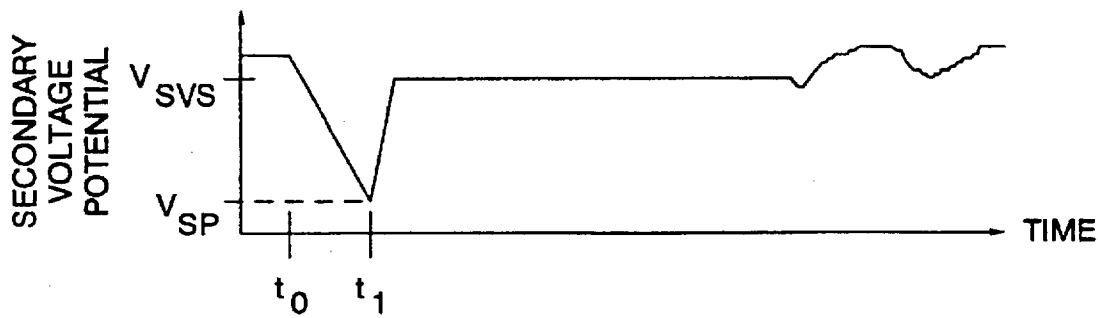

Fig. 6.



# Explore Litigation Insights

Docket Alarm provides insights to develop a more informed litigation strategy and the peace of mind of knowing you're on top of things.

## Real-Time Litigation Alerts



Keep your litigation team up-to-date with **real-time alerts** and advanced team management tools built for the enterprise, all while greatly reducing PACER spend.

Our comprehensive service means we can handle Federal, State, and Administrative courts across the country.

## Advanced Docket Research



With over 230 million records, Docket Alarm's cloud-native docket research platform finds what other services can't. Coverage includes Federal, State, plus PTAB, TTAB, ITC and NLRB decisions, all in one place.

Identify arguments that have been successful in the past with full text, pinpoint searching. Link to case law cited within any court document via Fastcase.

## Analytics At Your Fingertips



Learn what happened the last time a particular judge, opposing counsel or company faced cases similar to yours.

Advanced out-of-the-box PTAB and TTAB analytics are always at your fingertips.

## API

Docket Alarm offers a powerful API (application programming interface) to developers that want to integrate case filings into their apps.

## LAW FIRMS

Build custom dashboards for your attorneys and clients with live data direct from the court.

Automate many repetitive legal tasks like conflict checks, document management, and marketing.

## FINANCIAL INSTITUTIONS

Litigation and bankruptcy checks for companies and debtors.

## E-DISCOVERY AND LEGAL VENDORS

Sync your system to PACER to automate legal marketing.