



US007067952B2

(12) **United States Patent**
Neal

(10) **Patent No.:** **US 7,067,952 B2**
(45) **Date of Patent:** **Jun. 27, 2006**

(54) **STATOR ASSEMBLY MADE FROM A MOLDED WEB OF CORE SEGMENTS AND MOTOR USING SAME**

(75) Inventor: **Griffith D. Neal**, Alameda, CA (US)

(73) Assignee: **Encap Motor Corporation**, Alameda, CA (US)

(*) Notice: Subject to any disclaimer, the term of this patent is extended or adjusted under 35 U.S.C. 154(b) by 248 days.

(21) Appl. No.: **10/383,219**

(22) Filed: **Mar. 5, 2003**

(65) **Prior Publication Data**

US 2004/0034988 A1 Feb. 26, 2004

Related U.S. Application Data

(63) Continuation-in-part of application No. 09/798,511, filed on Mar. 2, 2001, now Pat. No. 7,036,207.

(51) **Int. Cl.**

H02K 1/18 (2006.01)

H02K 15/02 (2006.01)

H02K 15/10 (2006.01)

(52) **U.S. Cl.** **310/259**; 310/42; 310/45; 310/218

(58) **Field of Classification Search** 310/42-43, 310/45, 216-218, 254, 259; 244/432, 433, 244/433.4; 29/596

See application file for complete search history.

(56) **References Cited**

U.S. PATENT DOCUMENTS

- 2,607,816 A * 8/1952 Ryder et al. 310/42
- 3,348,302 A * 10/1967 Foerster 29/605
- 3,590,328 A 6/1971 Frescura
- 3,638,055 A 1/1972 Zimmermann
- 3,802,066 A 4/1974 Barrett
- 3,827,141 A * 8/1974 Hallerback 29/596

- 3,874,073 A 4/1975 Dochterman et al.
- 3,908,138 A 9/1975 Shieh
- 3,942,054 A 3/1976 Kristen et al.
- 3,979,530 A 9/1976 Schwider et al.
- 4,015,154 A * 3/1977 Tanaka et al. 310/42
- 4,128,527 A 12/1978 Kinjo et al.
- 4,173,822 A 11/1979 Futterer et al.
- 4,352,897 A 10/1982 Ogata et al.
- 4,365,180 A 12/1982 Licata et al.
- 4,372,035 A 2/1983 McMillen

(Continued)

FOREIGN PATENT DOCUMENTS

BE 870878 1/1979

(Continued)

OTHER PUBLICATIONS

LNP Engineering Plastics, Advertisement entitled "Konduit™ Thermally Conductive Composites," undated (2 pages).

(Continued)

Primary Examiner—Burton Mullins

(74) *Attorney, Agent, or Firm*—Steven P. Shurtz; Brinks Hofer Gilson & Lione

(57) **ABSTRACT**

A plurality of stator arc segments 20 are linked together by a phase change material 22 enabling simplified winding and higher slot fill. Once wound this continuous structure can be formed into a toroidal core 17 for a stator assembly 40 used to make a motor 100. In a preferred embodiment, a monolithic body 42 of phase change material substantially encapsulates the conductors and holds the stator arc segments 20 in contact with each other in the toroidal core 17. Hard disc drives using the motor 100, and methods of constructing the motor 100 are also disclosed.

14 Claims, 5 Drawing Sheets

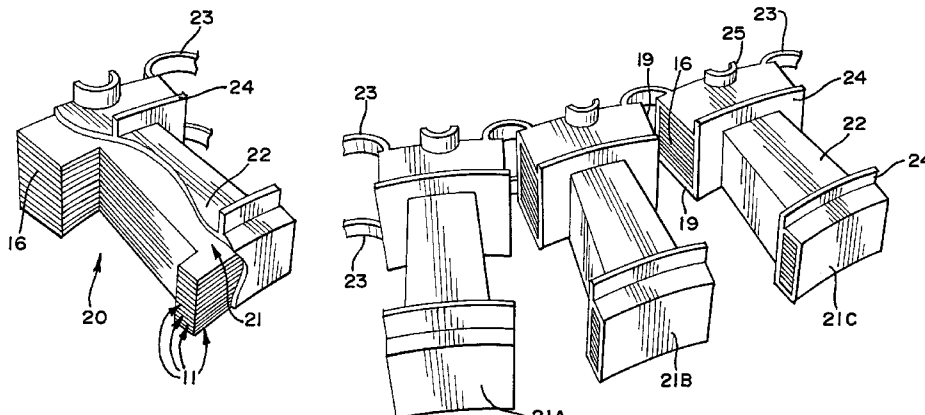

U.S. PATENT DOCUMENTS

4,387,311	A	6/1983	Kobayashi et al.
4,492,889	A	1/1985	Fukushi et al.
4,572,979	A	2/1986	Haar et al.
4,643,346	A	2/1987	Gotoh
4,679,313	A	7/1987	Schultz et al.
4,712,035	A	12/1987	Forbes et al.
4,760,299	A	7/1988	Dickie et al.
4,801,833	A	1/1989	Dye
4,818,911	A *	4/1989	Taguchi et al. 310/259
4,853,576	A	8/1989	Mayumi et al.
4,858,073	A	8/1989	Gregory
4,868,970	A	9/1989	Schultz et al.
4,954,739	A	9/1990	Schultz et al.
4,990,809	A	2/1991	Artus et al.
5,008,572	A	4/1991	Marshall et al.
5,036,580	A	8/1991	Fox et al.
5,073,735	A	12/1991	Takagi
5,075,585	A	12/1991	Teruyama et al.
5,121,021	A	6/1992	Ward
5,134,327	A	7/1992	Sumi et al.
5,142,103	A	8/1992	Stine
5,147,982	A	9/1992	Steffen
5,191,698	A	3/1993	Sumi et al.
5,206,554	A	4/1993	Perrot
5,268,607	A	12/1993	McManus
5,334,897	A	8/1994	Ineson et al.
5,345,129	A	9/1994	Molnar
5,382,852	A	1/1995	Yuhi et al.
5,396,210	A	3/1995	Purohit et al.
5,400,218	A	3/1995	Val
5,414,317	A	5/1995	Reid et al.
5,459,190	A	10/1995	Nakamura et al.
5,461,772	A	10/1995	Puri
5,500,780	A	3/1996	Boutaghou et al.
5,506,458	A	4/1996	Pace et al.
5,541,787	A	7/1996	Jabbari et al.
5,548,458	A	8/1996	Pelstring et al.
5,558,445	A	9/1996	Chen et al.
5,579,188	A	11/1996	Dunfield et al.
5,587,617	A	12/1996	Dunfield et al.
5,592,731	A	1/1997	Huang et al.
5,598,048	A	1/1997	Dunfield et al.
5,610,463	A	3/1997	Dunfield et al.
5,619,083	A	4/1997	Dunfield et al.
5,619,389	A	4/1997	Dunfield et al.
5,621,372	A	4/1997	Purohit
5,633,545	A	5/1997	Albrecht et al.
5,666,242	A	9/1997	Edwards et al.
5,668,427	A	9/1997	Morita
5,672,927	A	9/1997	Viskochil
5,675,196	A	10/1997	Huang et al.
5,694,268	A	12/1997	Dunfield et al.
5,698,919	A	12/1997	Obara
5,728,600	A	3/1998	Saxelby, Jr. et al.
5,729,072	A	3/1998	Hirano et al.
5,729,404	A	3/1998	Dunfield et al.
5,742,450	A	4/1998	Moser
5,751,085	A	5/1998	Hayashi
5,751,514	A	5/1998	Hyde et al.
5,766,535	A	6/1998	Ong
5,783,888	A	7/1998	Yamano
5,806,169	A	9/1998	Trago et al.
5,814,412	A	9/1998	Terada et al.
5,850,318	A	12/1998	Dunfield et al.
5,859,486	A	1/1999	Nakahara et al.
5,875,540	A	3/1999	Sargeant et al.
5,880,179	A	3/1999	Ito et al.
5,881,447	A	3/1999	Molnar
5,898,252	A	4/1999	Tanaka et al.

5,949,172	A	9/1999	Katagiri
5,958,466	A	9/1999	Ong
5,973,424	A	10/1999	Engelberger et al.
5,982,057	A	11/1999	Imada et al.
5,986,365	A	11/1999	Kuwert et al.
5,986,377	A	11/1999	Yamada et al.
5,990,247	A	11/1999	Terada et al.
6,002,185	A	12/1999	Nakao et al.
6,019,516	A	2/2000	Leuthold et al.
6,020,661	A	2/2000	Trago et al.
6,034,841	A	3/2000	Albrecht et al.
6,043,583	A	3/2000	Kurosawa et al.
6,049,153	A	4/2000	Nishiyama et al.
6,071,014	A	6/2000	Lee et al.
6,075,304	A	6/2000	Nakatsuka
6,081,059	A *	6/2000	Hsu 310/179
6,111,334	A *	8/2000	Horski et al. 310/254
6,153,959	A	11/2000	Lorenzo
6,163,952	A	12/2000	Takehara
6,167,610	B1	1/2001	Nakahara et al.
6,201,334	B1	3/2001	Sargeant et al.
6,265,800	B1	7/2001	Kimura et al.
6,265,804	B1	7/2001	Nitta et al.
6,300,695	B1	10/2001	Neal
6,362,554	B1	3/2002	Neal
6,437,464	B1	8/2002	Neal
6,501,616	B1	12/2002	Neal
6,617,721	B1	9/2003	Neal
6,658,721	B1 *	12/2003	Kazama et al. 29/596
6,753,628	B1	6/2004	Neal
6,844,636	B1	1/2005	Lieu et al.
6,892,439	B1	5/2005	Neal et al.
6,911,166	B1	6/2005	Neal
6,941,640	B1	9/2005	Neal et al.
2003/0081347	A1	5/2003	Neal
2005/0134124	A1	6/2005	Lieu

FOREIGN PATENT DOCUMENTS

BE	891258	3/1982
DE	25 39 492 A1	3/1977
EP	0 747 943 A2	12/1996
EP	0 883 171 A1	12/1998
FR	2 647 958	12/1990
JP	11-38937	* 8/1988
JP	04295256 A	* 10/1992
JP	05336722	12/1993
JP	10070870	3/1998
JP	410271719	10/1998
JP	11082508	3/1999
SU	1334297	8/1987
SU	1494148	7/1989
WO	WO 92/06532	4/1992
WO	WO 96/20501	7/1996
WO	WO 96/33533	10/1996
WO	WO 97/39870	10/1997

OTHER PUBLICATIONS

Product Information from Dupont Engineering Polymers entitled "Electrical/Electronic Thermoplastic Encapsulation," undated, Publ. Reorder No.: H-58633 (R, 96.7), 20 pages.

LNP Engineering Plastics, Press Release entitled "LNP Introduces First-Ever Line of Thermally Conductive Compounds," Jan. 28, 1999 (2 pages).

Buchanan Motor Works, Inc., article from the Internet entitled "Epoxy Seal—Prevents Down Time and Keeps

US 7,067,952 B2

Page 3

The Epoxylite Corporation, article from the Internet entitled "Vacuum Pressure Impregnation (VPI) Systems", Nov. 19, 1999, <<http://www.epoxylite.com/EpoxyliteEquipment.htm>>, 3 pages.

Neeltran Inc., article from the Internet entitled "Vacuum Pressure Impregnation (VPI)", Nov. 19, 1999, <<http://www.neeltran.thomasregister.com/olc/neeltran/neel9.htm>> 2 pages.
* cited by examiner

FIG. 1
PRIOR ART

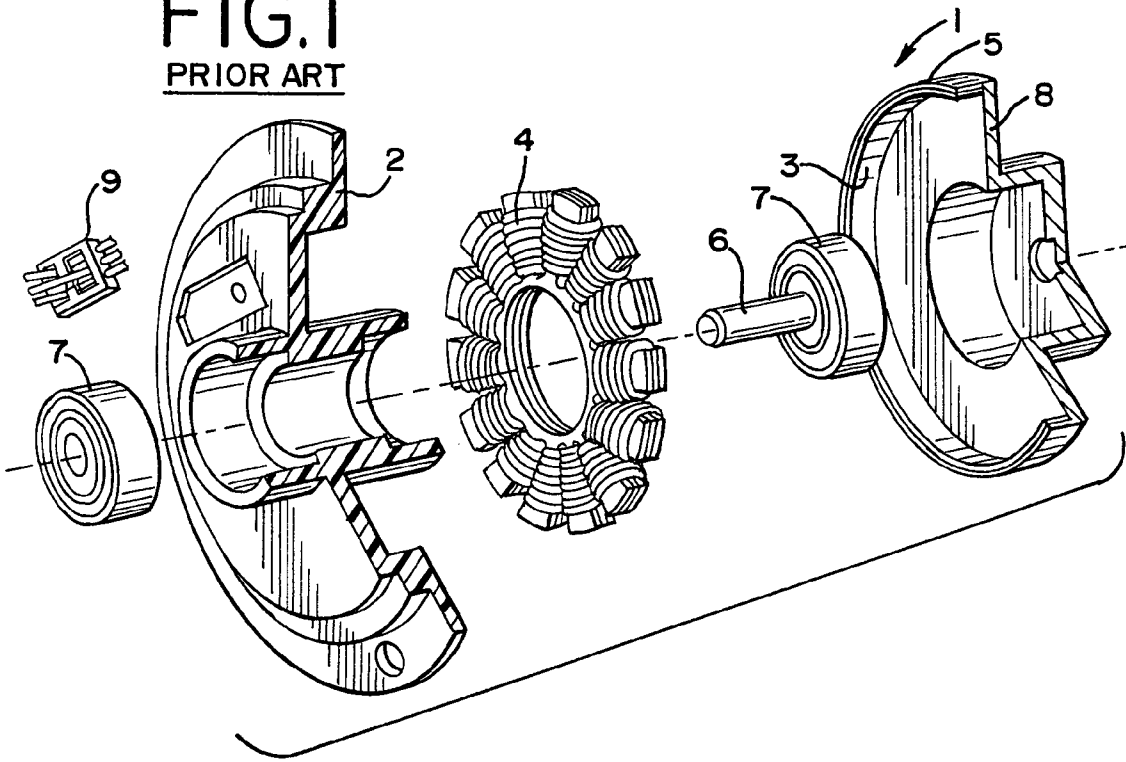

FIG. 2

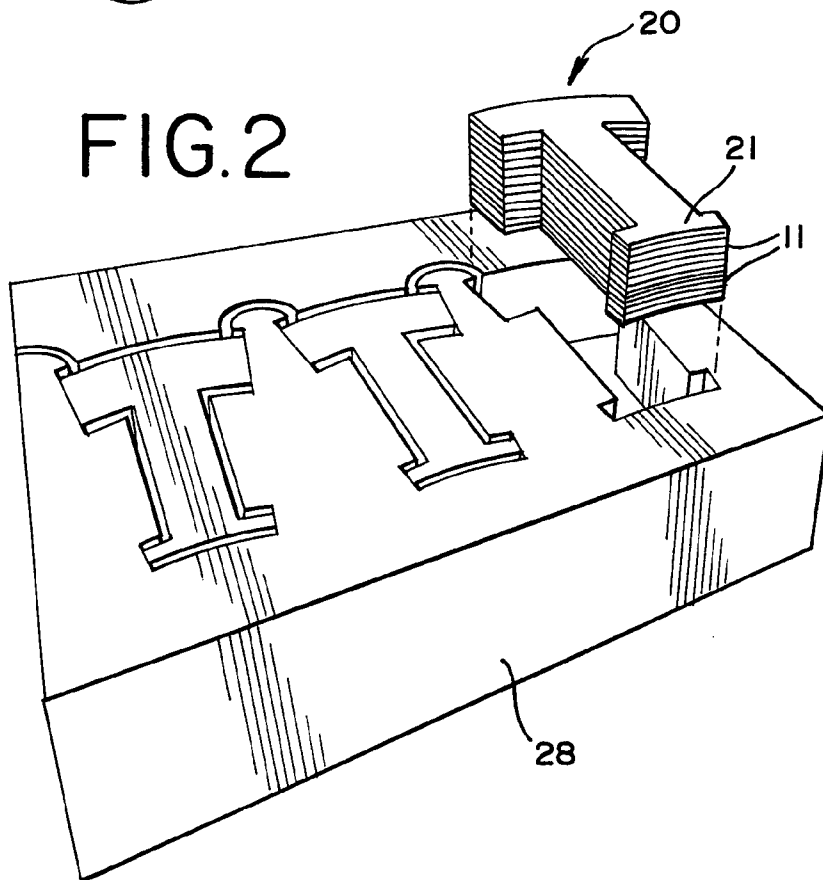

FIG.3

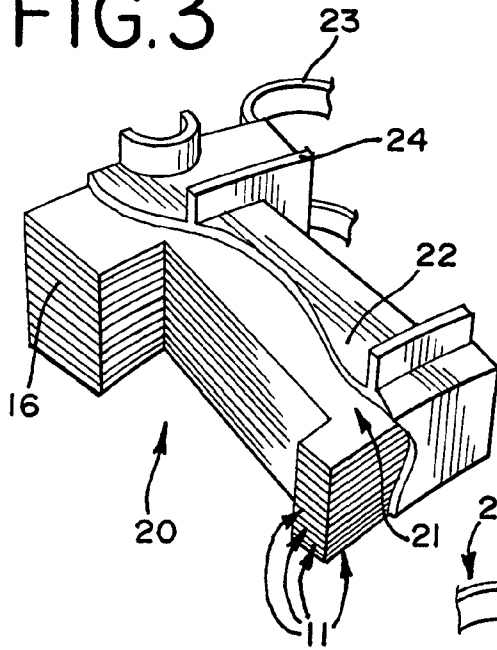

FIG.4

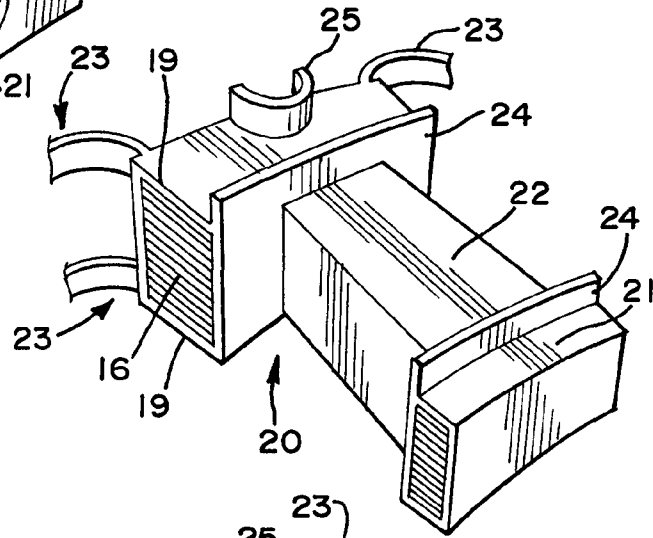
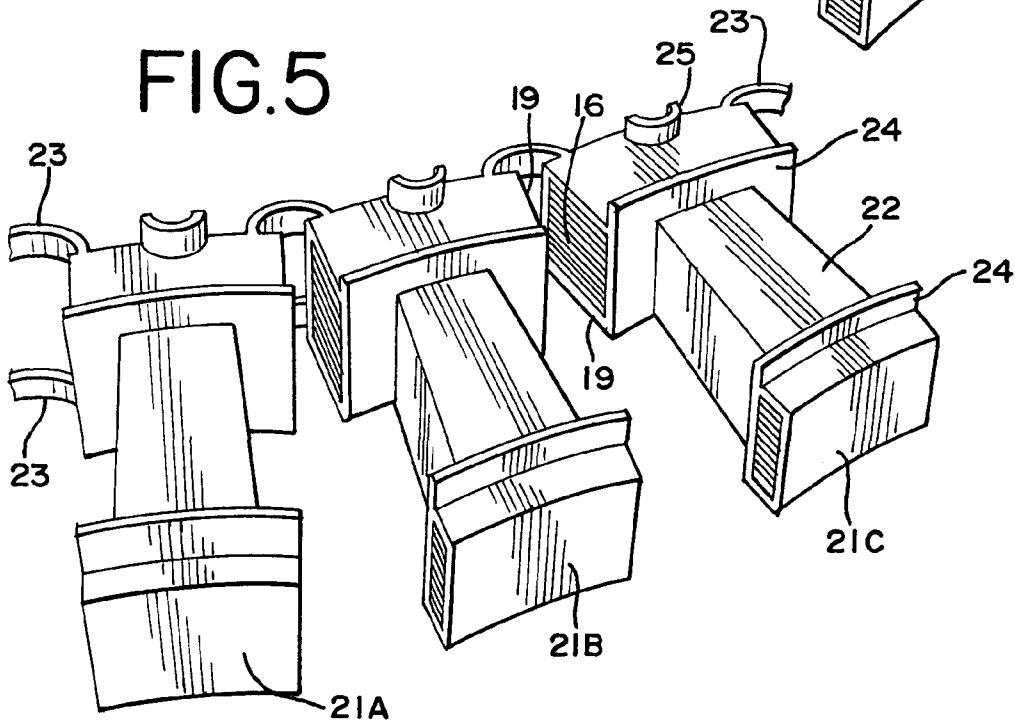

FIG.5



Explore Litigation Insights

Docket Alarm provides insights to develop a more informed litigation strategy and the peace of mind of knowing you're on top of things.

Real-Time Litigation Alerts



Keep your litigation team up-to-date with **real-time alerts** and advanced team management tools built for the enterprise, all while greatly reducing PACER spend.

Our comprehensive service means we can handle Federal, State, and Administrative courts across the country.

Advanced Docket Research



With over 230 million records, Docket Alarm's cloud-native docket research platform finds what other services can't. Coverage includes Federal, State, plus PTAB, TTAB, ITC and NLRB decisions, all in one place.

Identify arguments that have been successful in the past with full text, pinpoint searching. Link to case law cited within any court document via Fastcase.

Analytics At Your Fingertips



Learn what happened the last time a particular judge, opposing counsel or company faced cases similar to yours.

Advanced out-of-the-box PTAB and TTAB analytics are always at your fingertips.

API

Docket Alarm offers a powerful API (application programming interface) to developers that want to integrate case filings into their apps.

LAW FIRMS

Build custom dashboards for your attorneys and clients with live data direct from the court.

Automate many repetitive legal tasks like conflict checks, document management, and marketing.

FINANCIAL INSTITUTIONS

Litigation and bankruptcy checks for companies and debtors.

E-DISCOVERY AND LEGAL VENDORS

Sync your system to PACER to automate legal marketing.