

CONSTRUCTION, EXPRESSION AND CHARACTERIZATION OF HUMANIZED ANTIBODIES DIRECTED AGAINST THE HUMAN α/β T CELL RECEPTOR

CLYDE W. SHEARMAN,^{1*} DAN POLLOCK,* GARY WHITE,* KATHY HEHIR,*
GORDON P. MOORE,^{2*} E. J. KANZY,[†] AND ROLAND KURRLE[†]

From the *Genzyme Corporation, Framingham, MA 01701; and [†]Behringwerke Aktiengesellschaft, D-3550 Marburg, West Germany

Completely humanized antibodies with specificity for the human α/β TCR have been produced by genetic engineering. The L and H chain V region exons encoding the murine mAb BMA 031 CD regions and human EU framework regions were synthesized and replaced into previously isolated genomic fragments. These fragments were inserted into mammalian expression vectors containing the human κ and γ 1 C region exons. Two variants were constructed each containing selected BMA 031 amino acids within the human frameworks. The humanized genes were transfected into Sp2/0 hybridoma cells by electroporation and transfectomas secreting humanized antibody were isolated. Levels of antibody expression up to 7 pg/cell/24 h were obtained. The humanized antibody, BMA 031-EUCIV2, competed poorly with murine BMA 031 for binding to T cells. BMA 031-EUCIV3, however, bound specifically to T cells and competed effectively with both the murine BMA 031 antibody and a previously constructed chimeric BMA 031 antibody for binding to these cells. The relative affinity of BMA 031-EUCIV3 was about 2.5 times lower than BMA 031. The ability to promote antibody dependent cell-mediated cytotoxicity was significantly enhanced with the engineered antibodies as compared to murine BMA 031. Humanized BMA 031 is a clinically relevant, genetically engineered antibody with potential uses in transplantation, graft vs host disease, and autoimmunity.

mAb are emerging as a major modality for therapy of various pathologic conditions including malignant disease, cardiovascular disease, and autoimmune diseases. Some of these have demonstrated efficacy in treating colon carcinoma (1), B cell lymphomas (2), neuroblastoma (3), and in preventing transplant rejection (4, 5).

Clinical trials with murine antibodies, although encouraging, have indicated at least two fundamental problems of antibody therapy. First, murine IgG has a much shorter circulating half-life in man compared to what has been reported for human antibodies (6, 7), so that effec-

tive mAb therapy may require frequent multiple treatments with large amounts of murine antibody. Second, administration of murine IgG elicits a brisk HAMA³ response that can further reduce the circulating half-life of the mAb and produce allergic reactions including anaphylaxis (8-10).

Almost all of the murine mAb currently being used clinically provoke HAMA responses in patients. These include HAMA against both the C region and the V region (11). HAMA responses lead to altered pharmacokinetics of the injected mAb. The antibody is rapidly cleared from the serum and reduced antibody levels are attained (12). Although severe side effects are rare in patients with HAMA after retreatment with antibody, it is clear that if mAb are to be used therapeutically, reliable methods must be devised to reduce immune mediated complications or adverse reactions (13).

One approach to better immunotherapies currently being explored is to produce a truly human antibody. Unfortunately, human mAb technology has lagged far behind that of murine-based monoclonal technology. Human hybridomas are difficult to prepare, are often unstable, and secrete antibody at low levels (14, 15). The mAb generated are usually of the IgM class and of low affinity.

An attractive and viable strategy is to produce "humanized" versions of murine mAb through genetic engineering. Methods have been devised to replace all regions of a murine antibody with analogous human regions (16-18). Chimeric antibody technology has been applied to several therapeutically important antibodies (19-24) and has been useful in class switching and the production of isotypes with specific effector functions (25, 26). A chimeric antibody composed of the V regions of murine mAb 171A and the human γ 1C region has recently been used in patients with colon cancer. Whereas murine 171A has been used extensively in clinical trials and elicits a very pronounced HAMA response that alters its pharmacokinetics, antibody responses to chimeric 171A have been dramatically reduced. Moreover, the circulating half-life was increased relative to murine 171A and higher serum levels could be maintained at lower infused doses (27). Thus, with judicious genetic engineering, it is possible to manipulate antibody pharmacokinetics to minimize toxic side effects.

Chimeric antibodies may be effective in lowering the HAMA response in patients and increasing serum half-lives, but these properties are still inferior to human

Received for publication March 18, 1991.

Accepted for publication September 16, 1991.

The costs of publication of this article were defrayed in part by the payment of page charges. This article must therefore be hereby marked advertisement in accordance with 18 U.S.C. Section 1734 solely to indicate this fact.

¹ Address correspondence and reprint requests to Dr. C. W. Shearman, Sterling Drug, Inc., 512 Elmwood Avenue, Sharon Hill, PA 19079.

² Present address Department of Molecular Genetics, SmithKline Beecham, 709 Swedeland Road, King of Prussia, PA 19406.

³ Abbreviations used in this paper: HAMA, human anti-murine antibody; ADCC, antibody dependent cell mediated cytotoxicity; FR, framework region.

antibodies. Inasmuch as chimeric antibodies are still 30% murine, enhanced efficacy may be obtained by humanizing the V regions. New technologies have recently been advanced to produce totally humanized antibodies by grafting the CDR of murine antibodies onto human FR (17, 28–30). The resulting antibodies when expressed with human C regions should be essentially human. This technology, although technically straightforward, is not always totally successful. Selected FR amino acids appear to be involved in Ag binding. Identification of important FR amino acids has been achieved, up to now, by the use of x-ray crystallographic data (17) and sophisticated computer modeling (30) and several totally humanized antibodies have been produced with affinities close to those of their parental antibodies (17, 28–30).

We report here the production of a humanized antibody, without the use of sophisticated structural data, which retains the affinity and specificity of BMA 031, a murine mAb directed against the human α/β TCR. Moreover, humanized BMA 031 displays enhanced ADCC activity. BMA 031 has been used successfully in preventing organ transplant rejection (5) and may have potential efficacy in other T cell-related disorders.

MATERIALS AND METHODS

Cell culture. The BMA 031 and Sp2/0-Ag14 hybridomas were cultured in DMEM media supplemented with 10% FCS, 2 mM L-glutamine, 10 mM HEPES, pH 7.3, 10 mM nonessential amino acids (GIBCO, Gaithersburg, MD), and 10 mM pyruvate. Chimeric and humanized BMA 031 transfectomas were grown in the above media containing 1 $\mu\text{g}/\text{ml}$ mycophenolic acid, 50 $\mu\text{g}/\text{ml}$ xanthine, and 500 $\mu\text{g}/\text{ml}$ Geneticin (GIBCO). All lines were maintained at 37°C in 7% CO₂.

Computer analysis. Sequences were manipulated and homology searches were performed with the Genetics Computer Group Sequence Analysis Software Package (University of Wisconsin Biotechnology Center, Madison, WI) using the National Biomedical Research Foundation databases.

Synthesis of VH and VL regions. The VH and VL exons were synthesized on an Applied Biosystems (Foster City, CA) model 380A DNA synthesizer. Each region was synthesized completely as EcoRI-HindIII fragments consisting of overlapping (10–15 nucleotide overlap) oligomers (75–110 nucleotides). The oligomers were deprotected and purified by electroelution from polyacrylamide gels. The oligomers were then mixed in equimolar amounts (30 pmol), phosphorylated, annealed, and ligated into pUC 19 previously digested with EcoRI and HindIII.

Nucleotide sequencing. DNA sequencing of the synthesized VH and VL regions was performed directly on pUC subclones using universal forward and reverse primers (31).

Construction of humanized genes. To ensure efficient expression, the synthesized V regions were inserted into previously isolated genomic fragments (24) in place of the murine V regions. The resulting 5.6-kb EcoRI VH fragment was cloned into a mammalian expression vector containing the human $\gamma 1$ C region and the *gpt* gene for selection. The 3.0-kb HindIII VL fragment was cloned into a vector containing the human κ C region and the *neo* gene (see Fig. 5).

Transfection of DNA into Sp2/0 cells by electroporation. DNA was introduced into murine hybridoma Sp2/0-Ag14 cells by electroporation. The 1 to 2 $\times 10^7$ actively growing Sp2/0-Ag14 cells were washed and resuspended in 1.0 ml of sterile PBS. A total of 15 μg of each humanized, Ig κ and IgG1, plasmid (linearized with BamHI) was added to the cell suspension. The DNA/cells were transferred to a precooled shocking cuvette, incubated on ice at least 5 min and then a 0.5 kv/cm electric pulse was delivered for 10 ms (Transfector 300, BTX, San Diego, CA). After shocking, the DNA/cell mixture was returned to ice for 10 min and then diluted in 40 ml of supplemented DMEM and incubated at room temperature for 10 min. Finally, the cells were transferred to a 37°C incubator with 7% CO₂ for 48 h before plating in selective medium, containing 1 $\mu\text{g}/\text{ml}$ mycophenolic acid, 50 $\mu\text{g}/\text{ml}$ xanthine, and 1 mg/ml Geneticin. Cells were plated in 96-well plates at 3 $\times 10^4$ cells/well.

Cytofluorometric assay for affinity. To analyze the relative affinities of murine, chimeric, and humanized BMA 031 antibodies,

competitive immunofluorescence assays were carried out. PBMC were separated by Ficoll-Hypaque density gradient centrifugation and incubated on ice for 1 h in the dark with mAb at various concentrations (0.05–50 $\mu\text{g}/\text{ml}$) premixed with either FITC-BMA031 or FITC-BMAEUCIV3 (2 $\mu\text{g}/\text{ml}$). Unbound antibodies were removed by two washing steps. Cells from all experiments were analyzed either on an Ortho (Raritan, NJ) Cytofluorograph 50H/2150 Computer System or on a Becton Dickinson (Mountain View, CA) FACStar Plus as described elsewhere (32). The intensity of fluorescence was calculated by modified Ortho or standard FACStar Plus software and is expressed as mean channel number.

Cytotoxicity assays. To measure the cytolytic capacity of the BMA 031 antibody preparations, a 20 h [⁵¹Cr] release assay was performed to measure ADCC and NK activity. [⁵¹Cr]-labeled HPB-ALL target cells were incubated with (ADCC) or without (NK activity) various concentrations of antibodies for 20 h in the presence of Ficoll-separated PBL (effector cells). α/β TCR negative CEM cells were used as control target cells. The antibodies were allowed to bind first to target cells (30 min) before the effector cells were added. The E:T cell ratio varied from 1:1 to 50:1. Cytolysis in the absence of antibodies was considered to be due to NK activity. The percentage of specific lysis was calculated as described earlier (33). Spontaneous [⁵¹Cr] release in the absence of effector cells and in the presence of the antibodies being tested was always less than 5%. All samples were analyzed in triplicate.

RESULTS

Designing humanized BMA 031 antibodies. To determine the optimal human sequence with which to humanize the murine BMA 031 antibody, the murine BMA 031 amino acid sequence was used to search the NBRF data base for the most homologous human antibody. Inasmuch as molecular models of antibodies show strong interactions between the H and L chains, we decided to use the H and L chain from the same human antibody. The human EU antibody turned out to be the best overall choice. The homology between the BMA 031 and EU FR (nos. 1–3) was 79% (67% identical) for the H chain and 81% (63% identical) for the L chain. The BMA 031 antibody uses JH3 and JK5. These are most homologous to human JH4 and JK4. A first generation humanized BMA 031 antibody would contain BMA 031 CDR, EU FR, and homologous human J regions. We refer to this antibody as BMA 031-EUCIV1 (Fig. 1).

A refinement to this basic humanized version can be made in the sequence immediately before and after the CDR. The CDR are assigned based on sequence homology data (34). Molecular models of antibodies have shown that the actual CDR loops can contain amino acids up to five amino acids away from the “Kabat” CDR (36). Also, Reichmann et al. (17) have shown the functional importance of a FR amino acid four residues from a CDR. Therefore, maintaining at least the major amino acid differences (in size or charge) within four amino acids of the CDR as murine may be beneficial. We refer to the antibody containing these changes as BMA 031-EUCIV2 (Fig. 1). Additionally, all differences within four amino acids of the CDR could be maintained murine. We refer to this antibody as BMA 031-EUCIV3.

Further refinements can be made, but, without complex computer modeling, it is difficult to prioritize their importance. For example, several amino acids are either BMA 031 specific or EU specific (i.e., different from the consensus sequence within their subgroups). Inasmuch as these amino acids presumably arose through somatic mutation to enhance their respective activities, it would seem logical to maintain the BMA 031-specific amino acids and change the EU-specific amino acids to the human consensus. But this can have potential adverse

```

      10          30          50
EU  QVQLVQSGAEVKKPGSSVKVCSKASGCTPFRSRAIIWVRQAPGQGLEWVHGCIIVPMFGPPNY
BMA  E  Q  P  LV  A  M      YK  TSYVMH  K  K      I  Y  N  YNDVTK
CIV-1 SYVMH
CIV-2 YK  TSYVMH
CIV-3 YK  TSYVMH  K      I  Y  N  YNDVTK
      \CDR/
      1      \----CDR-2

      70          90          110
EU  AQKFQGRVTTITADESTNTAYMELSSLRSEDTAFYFCAGG. YGIYSPEEY. .NGGLVTVSS
BMA  NE  K  KA  L  S  K  SS      T  S  VHY  R  S  YD  DGFV  WGO  T  A
CIV-1 NE  K
CIV-2 NE  K  A
CIV-3 NE  K  KA  L
      \----/
      \--CDR-1--/
      \--CDR-3--/

```

B

```

      10          30          50
EU  DIQMTQSPFSTLSASVGRVITTCRASQSINTVLAWYQQKPGKAPKLLMYKASSLESGVPS
BMA  Q  VL  AIM  P  EK  M  S  TS  V.  SYMH  S  TS  RWI  DT  K  A  A
CIV-1 S  TS  V.  SYMH  S  TS  RWI  DT  K  A  A
CIV-2 S  TS  V.  SYMH  R  DT  K  A  A
CIV-3 M  S  TS  V.  SYMH  RWI  DT  K  A  A
      \--CDR-1--/
      \CDR-2/

      70          90
EU  RFIGSGSGTEFTLTISLQPDFFATYYCQQYNSDSKMFQGGTKVEVK
BMA  S  SYS  MEAE  A  WS  NPLT  A  L  L
CIV-1 WS  NPLT  G  I
CIV-2 WS  NPLT  G  I
CIV-3 WS  NPLT  G  I
      \--CDR-3--/

```

Figure 1. Amino acid sequences of EU, BMA 031, and humanized BMA 031 V regions. A, The VH region and B, the VL region. The positions of the CDR are indicated.

TABLE I
Amino acid (AA) differences between BMA 031 and EU and their consensus sequences

AA Position ^a	EU AA	Human AA	BMA031 AA	Mouse AA
H chain, EU specific				
70	Ile	^b	Leu	Leu
72	Ala	^b	Ser	Val
74	Glu	^b	Lys	Lys
93	Phe	Val	Val	Val
95	Phe	Tyr	Tyr	Tyr
98	Gly	Arg	Arg	Arg
L chain, EU specific				
10	Thr	Ser	Ile	Ile
48	Met	Ile	Ile	Ile
63	Ile	Ser	Ser	Ser
70	Glu	Asp	Ser	Ser
81	Asp	Glu	Glu	Glu
H chain, BMA specific				
1	Gln	Gln	Glu	Gln
7	Ser	Ser	Ser	Pro
9	Ala	Ala	Pro	Ala
20	Val	Val	Met	Leu
40	Ala	Ala	Lys	Arg
72	Ala	^b	Ser	Val
82	Glu	Glu	Glu	Gln
94	Tyr	Tyr	His	Tyr
L chain, BMA specific: None				

^a Numbers correspond to those in Figure 1.

^b Variable.

consequences. Changing an amino acid in one chain may cause changes in the interactions with other amino acids of that chain as well as with amino acids in the other chain. Therefore, extreme caution must be exercised to limit the number of changes. Table I outlines these potential changes. The residue numbers correspond to those in Figure 1. As can be seen, EU differs from the human VH-I subgroup consensus sequence in six positions. Three are within four amino acids of the CDR (nos.

70, 95, and 98), and these are addressed in BMA-031-EUCIV3. In one position (no. 93) the human consensus sequence is the same as BMA 031. Moreover, the Phe₉₃ in EU is highly unusual; this amino acid is only found in this position in one other human antibody in subgroup VH-III. One could rationalize changing this from EU to the human consensus, so we incorporated this change into BMA 031-EUCIV3. For the two remaining positions (nos. 72 and 74), there is no clear human consensus so we maintained the EU sequence. The L chain had five EU-specific amino acids. One is within four amino acids of the CDR (no. 48) and is maintained as BMA 031 in BMA 031-EUCIV3. In two positions (nos. 63 and 81) the human consensus is the same as BMA 031 and therefore could be changed to the human consensus. We decided not to make these changes at this time. The other two positions (nos. 10 and 70) were also not changed to limit the number of substitutions. There are eight BMA 031 specific amino acids in the H chain. In two positions (nos. 7 and 82) the BMA 031 sequence is the same as EU. His₉₄ is unique to BMA 031. This position is considered "invariant" with Tyr₉₄ occurring more than 98% of the time. Therefore, we decided to incorporate this change into BMA 031-EUCIV3. The remaining five positions (nos. 1, 9, 20, 40, and 72) were maintained EU to limit the number of changes. There are no BMA 031-specific amino acids in the L chain. The sequence is identical to the subgroup VI consensus. The changes in the human EU framework sequence back to BMA 031 are summarized in Table II. Twelve changes were made in the H chain; 5 in BMA 031-EUCIV2 and 7 more in BMA 031-EUCIV3. Five changes were introduced into the L chain; two in BMA 031-EUCIV2 and three more in BMA 031-EUCIV3.

Determination of DNA sequence for humanized V regions. The amino acid sequence of the V regions were reverse translated using the actual BMA 031 codons wherever possible and BMA 031 codon preferences everywhere else. To aid in future modifications, unique restriction enzyme sites were engineered into the sequence at approximately 60-bp intervals by making use of the degeneracy of the genetic code. Finally, convenient restriction enzyme sites 5' and 3' of the coding region of BMA 031 were identified and this flanking sequence was incorporated into the final humanized sequence to be syn-

TABLE II
Amino acid (AA) changes in EU FR

AA Position ^a	EU AA	BMA031 AA	CIV2 AA	CIV3 AA
H chain				
27	Gly	Tyr	Tyr	Tyr
28	Thr	Lys	Lys	Lys
30	Ser	Thr	Thr	Thr
38	Arg	Lys	Arg	Lys
48	Met	Ile	Met	Ile
67	Arg	Lys	Arg	Lys
68	Val	Ala	Ala	Ala
70	Ile	Leu	Ile	Leu
93	Phe	Val	Phe	Val
94	Tyr	His	Tyr	His
95	Phe	Tyr	Phe	Tyr
98	Gly	Arg	Arg	Arg
L chain				
21	Ile	Met	Ile	Met
46	Leu	Arg	Arg	Arg
47	Leu	Trp	Leu	Trp
48	Met	Ile	Met	Ile
60	Ser	Ala	Ala	Ala

^a Numbers correspond to those in Figure 1.

thesized. The final DNA sequences of BMA 031-EUCIV2 VH and VL, excluding the *EcoRI* and *HindIII* cloning ends, are shown in Fig. 2.

Synthesis of humanized BMA 031 V regions. The L and H chain V region exons encoding the humanized antibodies were synthesized completely as *EcoRI-HindIII* fragments consisting of 10 to 15 overlapping (10–15 nucleotide overlap) oligomers (75–110 nucleotides). The oligomers were phosphorylated, annealed and ligated into a pUC vector previously cut with *EcoRI* and *HindIII*. The assembled fragments were sequenced to verify accuracy of synthesis.

Reconstruction of BMA 031 genomic fragments with humanized V exons. To increase the probability of efficient expression of the synthesized coding regions, the humanized sequences were replaced into the previously isolated 5.6-kb *EcoRI* VH and 3.0-kb *HindIII* VL genomic fragments of BMA 031 (Fig. 3). Due to the lack of unique restriction enzyme sites, several subclonings were necessary. To achieve this goal, four vectors, each containing modified genomic subfragments, were constructed. The first vector, pUCBMAVH-1.0HΔN was constructed by subcloning the 1.0-kb *HindIII* BMA 031 VH fragment into pUC19 with subsequent deletion of the 5'-*NsiI* site. The second vector, pUCΔHBMAVH-5.6RΔH, was derived by cloning the 5.6-kb *EcoRI* BMA 031 VH fragment into a pUC19 vector with a previously deleted *HindIII* site. The 5'-*HindIII* site of the insert was then deleted to complete the construction. The third vector, pUCBMAVL-1.4RH2, was constructed by subcloning the 1.4-kb *EcoRI-HincII* BMA 031 VL fragment into pUC19. The fourth vector, pUCΔRSBMAVL-3.0H, was made by cloning the 3.0-kb *HindIII* BMA 031 VL fragment into a pUC19 vector that had a previous deletion from the *EcoRI* site to the *Sall* site in the polylinker.

The cloning scheme to replace the humanized sequences into the genomic fragments is outlined in Figure 4. The newly synthesized *SauI-NsiI* BMA 031-EUCIV2

VH fragment was isolated from the pUC19 subclone and cloned into pUCBMAVH-1.0HΔN. Then, the 1.0-kb *HindIII* fragment was isolated and cloned into pUCΔHBMAVH-5.6RΔH. Finally, the 5.6-kb *EcoRI* fragment was isolated and subcloned into the mammalian expression vector containing the human γ 1 C region and the *gpt* gene for selection (Fig. 5).

The newly synthesized *SauI-HincII* BMA 031-EUCIV2 VL fragment was isolated and cloned into pUCBMAVL-1.4RH2. Then, the 1.4-kb *EcoRI-HincII* fragment was isolated and cloned into pUCΔRSBMAVL-3.0H. Finally, the 3.0 *HindIII* fragment was isolated and cloned into the mammalian expression vector containing the human κ C region and the *neo* gene for selection (Fig. 5).

The BMA 031-EUCIV3 constructs were prepared in the same manner as BMA 031-EUCIV2. Replacement oligomers incorporating the coding changes for BMA 031-EUCIV3 were synthesized and cloned into the pUCBMA-EUCIV2 constructs. The final clone was sequenced to ensure accuracy of the coding sequence. The BMA 031-EUCIV3 V regions were replaced into the original BMA 031 genomic fragments and these fragments were cloned into the mammalian expression vectors described above.

Expression and purification of humanized BMA 031 antibodies. The humanized genes were transfected into Sp2/0 hybridoma cells by electroporation and selected in media containing both mycophenolic acid and Geneticin. Transfectomas secreting humanized BMA 031 antibodies were identified by ELISA. Secretion levels up to 7 pg/cell/24 h were obtained. The best clone from each transfection (CIV2 and CIV3), with respect to secretion level and growth characteristics, was expanded for further study.

The BMA 031-EUCIV2 and -EUCIV3 antibodies were partially purified by protein A-Sepharose column chromatography. Analysis of the antibodies by reducing and nonreducing SDS-PAGE showed a high degree of purity (data not shown). Analysis by a series of ELISA assays showed that the antibodies contained human κ and γ 1 C

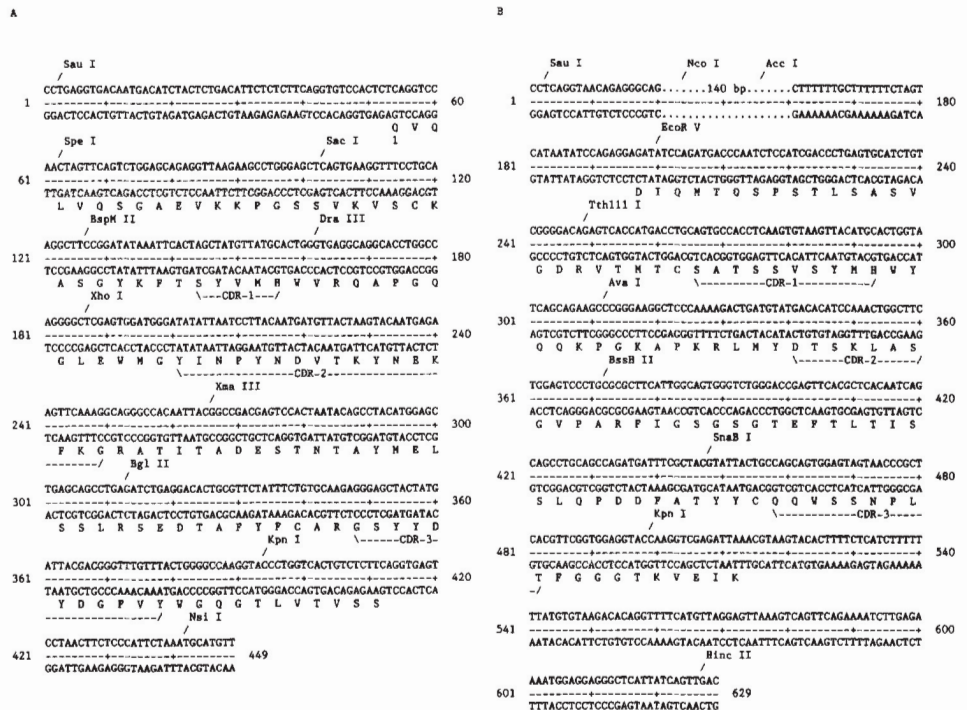

Figure 2. DNA sequences of the V regions of BMA 031-EUCIV2. A, The BMA 031-EUCIV2 VH region and B, the BMA 031-EUCIV2 VL region.

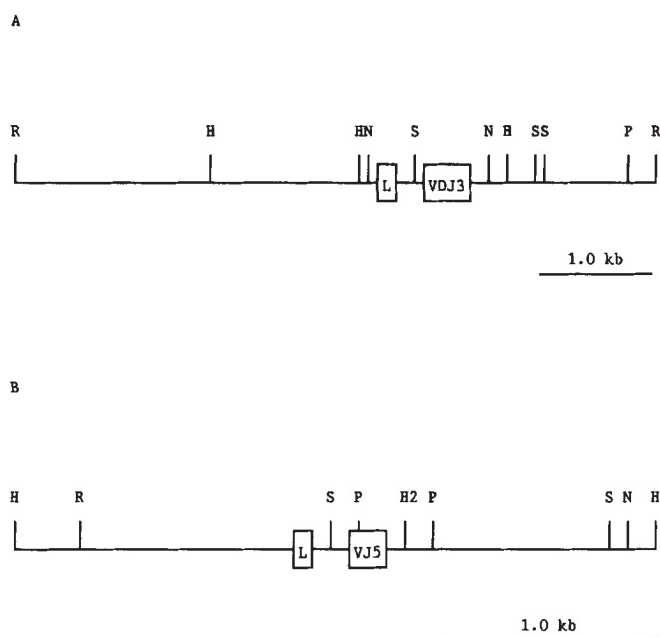

Figure 3. Partial restriction enzyme maps of BMA 031 V regions. A, The 5.6-kb *EcoRI* VH fragment containing the VDJ₃ exon. B, the 3.0-kb *HindIII* VL fragment containing the VJ₅ exons. H, *HindIII*; H2, *HincII*; N, *NsiI*; P, *PstI*; R, *EcoRI*; S, *SauI*.

regions. Moreover, the antibodies did not react with anti-murine antibodies (data not shown).

Characterization of humanized BMA 031 antibodies. The BMA 031-EUCIV2 antibody bound poorly to T cells. In contrast, BMA 031-EUCIV3 shows an identical specificity as murine BMA 031. They both bind specifically to T cells and show no reactivity toward monocytes, E, or granulocytes (data not shown).

The relative affinities of murine BMA 031, chimeric BMA 031 (human IgG1), and the humanized variants were compared by competitive immunofluorescence as-

says. The data shown in Figure 6 indicate that both the murine BMA 031 antibody and the previously constructed chimeric BMA 031-G1 antibody block the binding of BMA 031-FITC in the same dose-dependent manner. BMA 031-EUCIV3 was about 2.5 times less efficient than murine BMA 031. BMA 031-EUCIV2 was unable to totally block BMA 031-FITC binding, even at concentrations as high as 50 $\mu\text{g/ml}$.

BMA 031 has been shown to be poor at mediating ADCC using human effector cells. To evaluate the ADCC capacity of the humanized antibodies, we compared them to rabbit anti-GH-1 antiserum. This antiserum was the best of eight rabbit anti-human T cell globulins in ADCC capacity. As shown in Figure 7, both the chimeric BMA 031 antibody and the BMA 031-EUCIV3 antibody were very efficient at ADCC. Even at very low effector:target cell ratios (Fig. 7A) or extremely low antibody concentrations (Fig. 7, B and C), the engineered antibodies are highly potent at mediating killing of the HPB-ALL cells.

DISCUSSION

We have joined the DNA segments containing the CDR from the BMA 031 mAb specific for the α/β TCR and the FR from the human EU antibody to the DNA segments encoding human γ -1 and κ C regions. When the humanized genes were introduced into non-Ig producing Sp2/0 cells, functional humanized antibodies specific for T cells were assembled and secreted.

Functional antibody, however, was dependent on substitution of various murine FR amino acids into the human FR. The identification of important FR amino acids in the absence of structural data or computer models is difficult but, by careful analysis of antibody sequence homologies, it is possible to generate a humanized sequence with a high probability of maintaining Ag binding. Our method consists of three parts. First, and possibly most important, is starting with the human antibody most homologous to the murine antibody under

Figure 4. The cloning scheme to regenerate the BMA 031 genomic fragments with the humanized V regions. A, Substituting the humanized VH region into the 5.6-kb *EcoRI* VH fragment. BH, BMA 031 VH exon; CH, humanized BMA 031 VH exon; p1, pUCBMAVH-1.0H Δ N; p2, pUCBMACIVH; p3, pUCBMACIVH-1.0H Δ N; p4, pUC Δ HBMVH-5.6R Δ H; p5, pUC Δ HBMACIVH-5.6R Δ H; p6, pSV2gpt-hu γ 1; p7, pSV2gpt-BMACIVH-hu γ 1. B, Substituting the humanized VL region into the 3.0 *HindIII* VL fragment. BL, BMA 031 VL exon; CL, humanized BMA 031 VL exon; p8, pUCBMAVL-1.4RH2; p9, pUCBMACIVL; p10, pUCBMACIVL-1.4RH2; p11, pUC Δ RSBMAVL-3.0H; p12, pUC Δ RSBMACIVL-3.0H; p13, pSV2neo-hu κ ; p14, pSV2neo-BMACIVL-hu κ . Restriction enzyme sites identified are: H, *HindIII*; H2, *HincII*; N, *NsiI*; R, *EcoRI*; S, *SauI*.

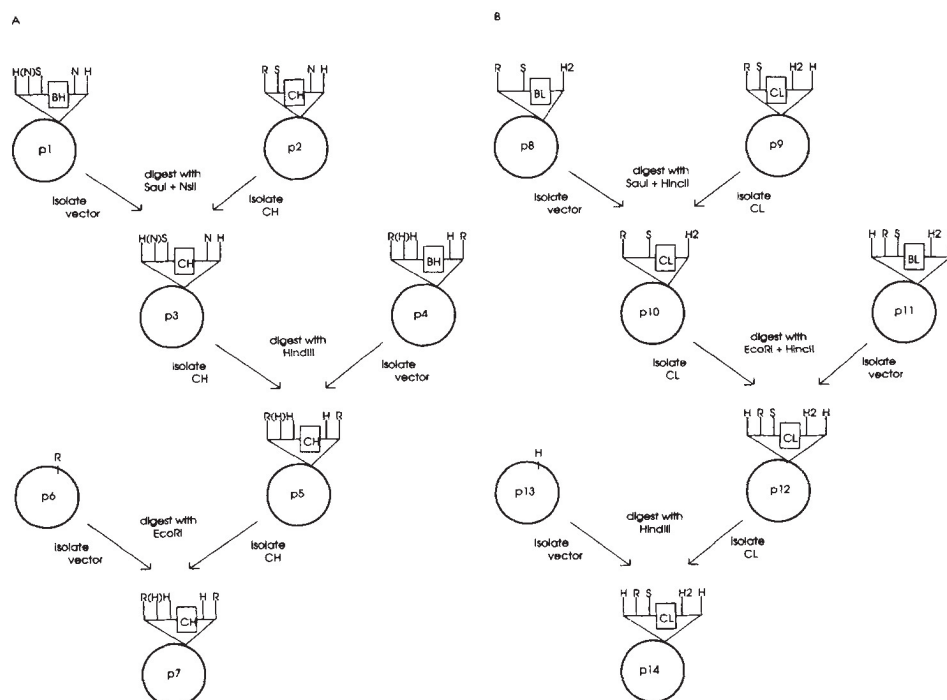

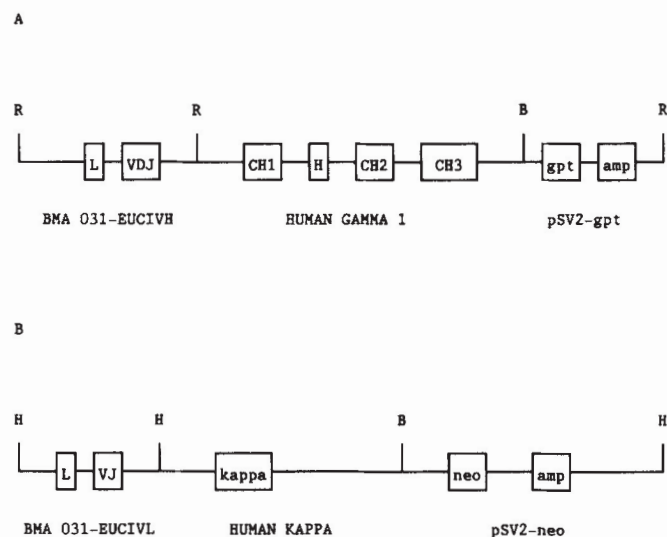

Figure 5. Expression vectors for humanized BMA 031 V regions. A, The H chain expression vector containing the humanized BMA 031 VH region, the human γ 1 C region, and the guanine phosphoribosyl transferase gene for selection. B, The L chain expression vector containing the humanized BMA 031 VL region, the human κ C region and the neomycin resistance gene for selection.

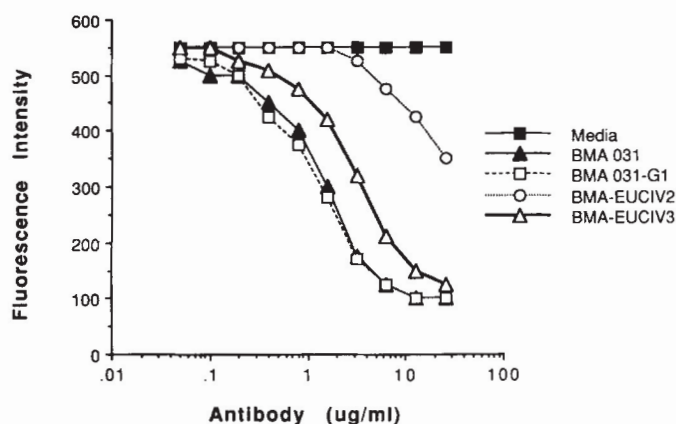

Figure 6. Relative affinities of BMA 031 antibodies. Competitive immunofluorescence assays with the BMA 031 antibodies, HPB mononuclear cells and BMA 031-FITC (2 μ g/ml) were performed as outlined in *Materials and Methods*. Intensity of fluorescence is expressed as mean channel number.

study. This effectively limits the number of amino acid differences that must be addressed. Second, because the assignment of CDR is based on homology and not function, the choice of maintaining the murine sequence on either side of the CDR is important. Evidence is emerging that the "functional" CDR loops can be displaced from the "Kabat" CDR by as many as five amino acids. Kabat et al. (34) places CDR-1 of the H chain V region from amino acids nos. 31 to 35 whereas crystal structure shows the loop to be from residues nos. 26 to 32 (35). Third, the identification of potentially "Ag specific" amino acids in both the human and murine antibody may be important. Although the identification may be straightforward, prioritizing their importance is very difficult. Inasmuch as the goal is to produce the most human-like sequence, these changes must be kept at a minimum. Our decision to keep similar amino acids human and only change the more unusual amino acids turned out to be correct in this instance. However, in the event that the humanized antibody was not functional, this analysis

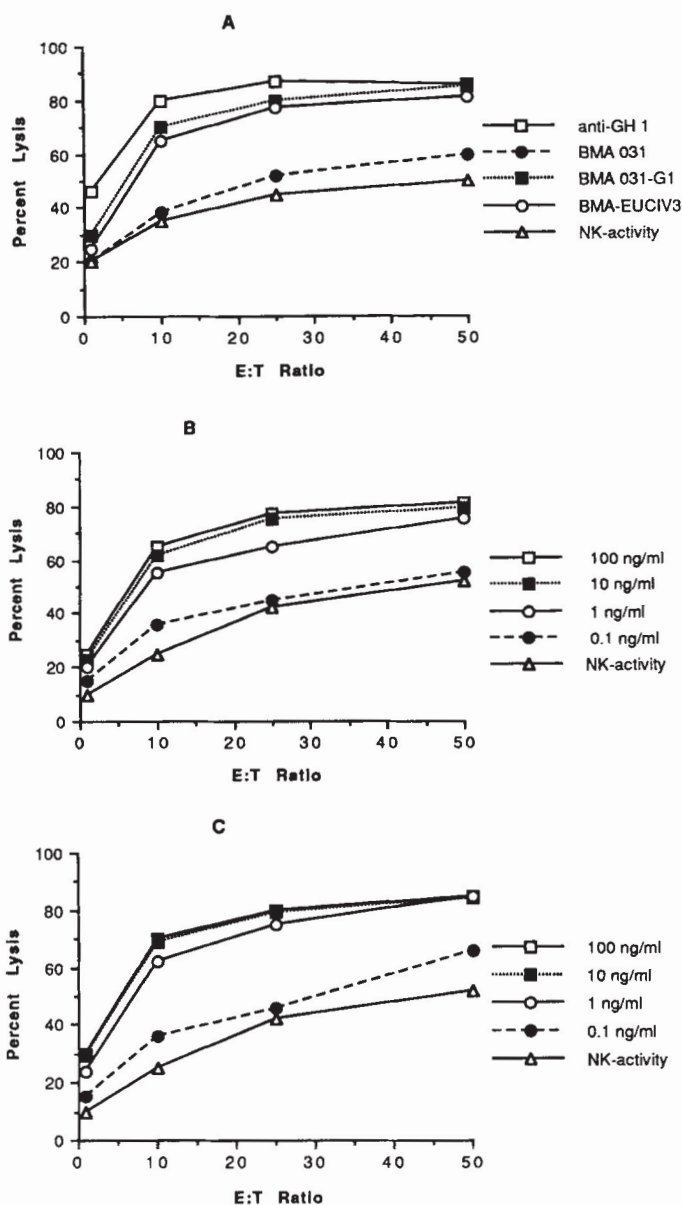

Figure 7. ADCC capacity of BMA 031 antibodies. The cytolytic capacity of the BMA 031 antibodies was determined in a 20 h [51 Cr] release assay as described in *Materials and Methods*. A, Lysis in the presence (ADCC) or absence (NK activity) of antibody (100 ng/ml). B, Lysis at various concentrations of BMA 031-EUCIV3. C, Lysis at various concentrations of chimeric BMA 031.

provides insight into those amino acids that could be altered to regain activity.

The T cell binding data with the humanized BMA 031 antibodies show the importance of FR amino acids in Ag binding. Inclusion of only the BMA 031 CDR (BMA 031-EUCIV1) would, most likely, not have been sufficient to maintain affinity for Ag. Twelve amino acid substitutions were made in the H chain V region to regain binding affinity (nos. 27, 28, 30, 38, 48, 67, 68, 70, 93, 94, 95, and 98). Of these, six may be more important (nos. 38, 48, 70, 93, 94, and 95) because they represent changes from BMA-EUCIV2, which does not bind well, to BMA 031-EUCIV3, which does bind well. Similarly, for the L chain V region, five amino acid substitutions were made (nos. 21, 46, 47, 48, and 60). Of these, three (nos. 21, 47, and 48) were made from BMA 031-EUCIV2 to BMA 031-EUCIV3 and thus may be more important.

The importance of any or all of these changes is difficult to assess. However, some of these changes appear to be quite significant. Five amino acid substitutions in the VH region stand out. Residues 70, 95, and 98 are both EU specific and fall within four amino acids of the CDR. Phe₉₃ in EU is highly unusual. Only one other human antibody had this residue in this position. His₉₄ in BMA 031 is also unusual. This is normally an invariant Tyr₉₄. In the L chain V region, residue 48 may be significant because it is both EU specific and within four amino acids of CDR-2.

Simple CDR replacement appears to be rarely successful, especially for antibodies directed against protein Ag. The initial attempt at humanizing an antibody involved only the H chain, used homologous human FR, and used antibody and Ag with solved crystal structures. The humanized antibody bound Ag about 10-fold less efficiently than the original murine antibody (29). The latest attempt to CDR-replace an antibody, reported to date, involved both the H and L chains of CAMPATH-1 (17). The resulting humanized antibody bound the CAMPATH-1 Ag very weakly. In both cases, the loss of binding activity was due to a single amino acid substitution in FR-1 of the H chain.

As shown above, simply replacing CDR sequences are not sufficient to ensure Ag-antibody binding. FR sequences obviously play a role in antibody affinity. The FR-1 amino acid identified above, Phe-27, was conspicuously missing from the human NEWM antibody. This alteration may have been important for NEWM activity but not for the activities of the other antibodies. It is interesting to note that Phe-27 is found in most human antibodies. This shows the importance of amino acid substitutions in particular antibody reactivities.

A study analyzing spontaneous variants of an anti-digoxin antibody-producing hybridoma demonstrated the importance of FR-3 amino acids. A single amino acid change at residue 94 of the H chain V region caused a reduction in affinity from 5.4×10^9 to 9.2×10^6 M⁻¹ (36). Spontaneous variant antibodies with reduced or absent Ag binding were also reported for phosphocholine and 4-hydroxy-3-nitro-5-iodophenyl-acetyl haptens (37-41). In these cases the structural changes were due to point mutations in either CDR or FR. A recent study by Queen et al. (30) used computer modeling to humanize the anti-Tac mab. They identified 10 potentially important FR amino acids that, when substituted into the final humanized sequence, yielded functional antibody. These results show the importance of FR amino acids on antibody affinity and the need for more detailed studies identifying the important sites.

Simple CDR replacement would only be successful, most likely, for antibodies that have undergone minimal affinity maturation. This would apply to both the murine and human antibodies. If affinity maturation involved the FR, then it becomes imperative to identify the "Ag specific" amino acids in the two antibodies. Perhaps using a germline human sequence or a human consensus sequence would be the best starting point for humanization. Then one would need only identify the important murine FR amino acids to include in the final sequence.

From the results presented, humanized BMA 031 may have clinical utility in preventing transplant rejection, graft vs host disease, autoimmune diseases, and other T

cell-related problems. The humanized antibody retains the affinity and specificity of murine BMA 031 but contains humanized V regions and human C regions that should eliminate the immune response in patients during immunotherapy. Also, effector functions associated with the human C regions are enhanced in vitro relative to murine BMA 031 and may also be in vivo when the humanized antibody is used for immunotherapy. We are now in a position to test the efficacy of humanized BMA031 in clinical trials.

It seems clear from the growing body of evidence that a fully engineered antibody would reduce immunogenicity to a minimum, increase circulating half-life and enhance effector functions; and as such would constitute, from both safety and efficacy considerations, a preferred form of a new antibody at the onset of the first human clinical trials.

Acknowledgment. We thank P. Thammana, D. Barone, and L. Sun for helpful discussions and K. Frank, W. Lang, and W. Seyfert-Brandt for expert technical assistance.

REFERENCES

1. Sears, H. F., D. Herlyn, Z. Steplewski, and H. Koprowski. 1985. Phase II clinical trial of a murine monoclonal antibody cytotoxic for gastrointestinal adenocarcinoma. *Cancer Res.* 45:5910.
2. Lowder, J. N., T. C. Meeker, M. Campbell, C. F. Garcia, J. Gralow, R. A. Miller, R. Warnke, and R. Levy. 1987. Studies on B lymphoid tumors treated with monoclonal anti-idiotypic antibodies: correlation with clinical responses. *Blood* 69:199.
3. Cheung, N.-R. V., H. Lazarus, F. D. Miraldi, C. R. Abramowski, S. Kallick, U. M. Saarinen, T. Spitzer, S. E. Strandjord, R. F. Coccia, and N. A. Berger. 1987. Ganglioside G2 specific monoclonal antibody 3F8: phase I study in patients with neuroblastoma and malignant melanoma. *J. Clin. Oncol.* 5:1430.
4. Goldstein, G., J. Schindler, H. Tsai, A. B. Cosimi, P. Russell, and D. Norman. 1985. A randomized clinical trial of OKT3 monoclonal antibody for acute rejection of cadaveric renal transplants. *N. Engl. J. Med.* 313:337.
5. Kurrle, R., K. H. Enssle, and F. R. Seiler. 1988. Monoclonal antibodies directed to leukocyte differentiation antigens for therapeutic use. *Behring Inst. Mitt.* 82:154.
6. LoBuglio, A. F., M. Saleh, L. Peterson, R. Wheeler, R. Carrano, W. Huster, and M. B. Khazaeli. 1986. Phase I clinical trial of CO17-1A monoclonal antibody. *Hybridoma* 5:117.
7. Morrell, A., W. D. Terry, and T. A. Waldmann. 1970. Metabolic properties of IgG subclasses in man. *J. Clin. Invest.* 49:673.
8. Shawler, D. L., R. M. Bartholomew, L. M. Smith, and R. O. Dillman. 1985. Human immune response to multiple injections of murine monoclonal IgG. *J. Immunol.* 135:1530.
9. Sears, H. F., D. Herlyn, Z. Steplewski, and H. Koprowski. 1984. Effects of monoclonal antibody immunotherapy on patients with gastrointestinal adenocarcinoma. *J. Biol. Response Mod.* 3:138.
10. Miller, R. A., A. R. Oseroff, P. T. Stratte, and R. Levy. 1983. Monoclonal antibody therapeutic trials in seven patients with T-cell lymphoma. *Blood* 62:988.
11. Jaffers, G. J., T. C. Fuller, A. B. Cosimi, P. S. Russell, H. J. Winn, and R. B. Colvin. 1986. Monoclonal antibody therapy—Anti-idiotypic and non-anti-idiotypic antibodies to OKT3 arising despite intense immunosuppression. *Transplantation* 41:572.
12. Khazaeli, M., M. Saleh, R. Wheeler, W. Huster, H. Holden, R. Carrano, and A. LoBuglio. 1988. Phase-1 trial of multiple large doses of murine monoclonal antibody Col7-1A 2. Pharmacokinetics and immune response. *J. Natl. Cancer Inst.* 80:937.
13. Byers, V. S., and R. W. Baldwin. 1988. Therapeutic strategies with monoclonal antibodies and immunoconjugates. *Immunology* 65:239.
14. Carson, D. A., and B. D. Freemark. 1986. Human lymphocyte hybridomas and monoclonal antibodies. *Adv. Immunol.* 38:275.
15. Morrison, S. L. 1985. Transfectomas provide novel chimeric antibodies. *Science* 229:1202.
16. Morrison, S. L., M. J. Johnson, L. A. Herzenberg, and V. T. Oi. 1984. Chimeric human antibody molecules: mouse antigen-binding domains with human constant region domains. *Proc. Natl. Acad. Sci. USA* 81:6851.
17. Reichmann, L., M. Clark, H. Waldmann, and G. Winter. 1988. Reshaping human antibodies for therapy. *Nature* 332:323.
18. Tan, L. K., and S. L. Morrison. 1988. Antibody structure and anti-

- body engineering. *Adv. Drug Deliv. Rev.* 2:129.
19. Shaw, D. R., G. Harrison, L. K. Sun, C. W. Shearman, S. McKinney, P. E. Dadonna, and A. F. LoBuglio. 1988. Human lymphocyte and monocyte lysis of tumor cells mediated by a mouse/human chimeric monoclonal antibody. *J. Biol. Response Modifiers* 7:204.
 20. Brown, B. A., G. L. Davis, J. Saltzberger-Muller, P. Simon, M.-K. Ho, P. S. Shaw, B. A. Stone, H. Sands, and G. P. Moore. 1987. Tumor specific genetically engineered murine/human chimeric monoclonal antibody. *Cancer Res.* 47:3577.
 21. Nishimura, Y., M. Yokoyama, K. Araki, R. Ueda, A. Kudo, and T. Watanabe. 1987. Recombinant human-mouse chimeric monoclonal antibody specific for common acute lymphocytic leukemia antigen. *Cancer Res.* 47:999.
 22. Liu, A. Y., R. Robinson, K. E. Hellstrom, E. D. Murray, C. P. Chang, and I. Hellstrom. Chimeric mouse-human IgG1 antibody that can mediate lysis of cancer cells. *Proc. Natl. Acad. Sci. USA* 84:3439.
 23. Li, Y.-W., D. K. Lawrie, P. Thammana, G. P. Moore, and C. W. Shearman. 1990. Construction, expression and characterization of a murine/human chimeric antibody with specificity for hepatitis B surface antigen. *Mol. Immunol.* 27:303.
 24. Shearman, C. W., E. J. Kanzy, D. K. Lawrie, Y.-W. Li, P. Thammana, G. P. Moore, and R. Kurrle. 1991. Construction, expression and biological activity of murine/human chimeric antibodies with specificity for the human alpha/beta T cell receptor. *J. Immunol.* 146:928.
 25. Shlom, J. 1988. Monoclonal antibodies in cancer therapy: the present and the future. *Biopharmacology* 1:44.
 26. Steplewski, Z., L. K. Sun, C. W. Shearman, P. Dadonna, and H. Koprowski. 1988. Biological activity of human-mouse IgG1, IgG2, IgG3 and IgG4 chimeric monoclonal antibodies with antitumor specificity. *Proc. Natl. Acad. Sci. USA* 85:4852.
 27. LoBuglio, A. F., R. H. Wheeler, J. Trang, A. Haynes, K. Rogers, E. B. Harvey, L. Sun, and M. B. Khazeli. 1989. Mouse/human chimeric monoclonal antibody in man: kinetics and immune response. *Proc. Natl. Acad. Sci. USA* 86:4220.
 28. Jones, P. T., P. H. Dear, J. Foote, M. S. Neuberger, and G. Winter. 1986. Replacing the complementarity determining regions in a human antibody with those from a mouse. *Nature* 321:522.
 29. Verhoeyen, M., C. Milstein, and G. Winter. 1988. Reshaping human antibodies: grafting an antilysozyme activity. *Science* 239:1534.
 30. Queen, C., W. P. Schneider, H. E. Selick, P. W. Payne, N. F. Landolfi, J. F. Duncan, N. M. Avdalovic, M. Levitt, R. P. Junghans, and T. A. Waldmann. 1989. A humanized antibody that binds to the interleukin 2 receptor. *Proc. Natl. Acad. Sci. USA* 86:10029.
 31. Chen, E. Y., and P. H. Seaberg. 1985. Supercoil sequencing: a fast and simple method for sequencing plasmid DNA. *DNA* 4:165.
 32. Kurrle, R., W. Seyfert, A. Trautwein, and F. R. Seiler. 1986. T cell activation by CD3 antibodies. In *Leukocyte Typing II*. E. L. E. Reinherz, ed. Springer-Verlag, New York, p. 137.
 33. Schrezenmeier, H., R. Kurrle, H. Wagner, and B. Fleischer. 1985. Activation of human T lymphocytes III. Triggering of bystander cytotoxicity in cytotoxic T cell clones by antibodies against the T3 antigen or by a calcium ionophore. *Eur. J. Immunol.* 15:1019.
 34. Kabat, E. A., T. T. Wu, M. Reid-Miller, N. M. Perry, and K. S. Gottesman. 1987. In *Sequences of Proteins of Immunological Interest*. United States Department of Health and Human Services, United States Government Printing Office, Washington, DC.
 35. Chothia, C., A. M. Lesk, M. Levitt, A. G. Amit, R. A. Mariuzza, S. E. V. Phillips, and R. J. Poljak. 1986. The predicted structure of immunoglobulin D1.3 and its comparison with the crystal structure. *Science* 233:755.
 36. Panka, D. J., M. Mudgett-Hunter, D. R. Parks, L. L. Peterson, L. A. Herzenberg, E. Haber, and M. N. Margolies. 1988. Variable region framework differences results in decreased or increased affinity of variant anti-digoxin antibodies. *Proc. Natl. Acad. Sci. USA* 85:3080.
 37. Rudikoff, S., A. M. Giusti, W. D. Cook, and M. D. Scharff. 1982. Single amino acid substitution altering antigen binding specificity. *Proc. Natl. Acad. Sci. USA* 79:1979.
 38. Tonegawa, S. 1983. Somatic generation of antibody diversity. *Nature* 302:575.
 39. Soebandrio, A., T. Azuma, Y. Hamada, N. Sakato, and H. Fujio. 1987. Specificity change of antibody to (4-hydroxy-3-nitrophenyl) acetyl haptens by somatic hypermutation. *J. Biochem.* 102:1337.
 40. Gearhart, P., N. D. Johnson, R. Douglas, and L. Hood. 1981. IgG antibodies to phosphorylcholine exhibit more diversity than their IgM counterparts. *Nature* 291:29.
 41. Bruggermann, M., H. J. Miller, C. Burger, and K. Rajewski. 1986. Idiotypic selection of an antibody mutant with changed hapten binding specificity resulting from a point mutation in position 50 of the heavy chain. *EMBO J.* 5:1561.