



(12) **United States Patent**
Lei et al.

(10) **Patent No.:** **US 6,401,127 B1**
(45) **Date of Patent:** **Jun. 4, 2002**

- (54) **ADAPTIVE TIMER FOR LLC TYPE 2 RELIABLE TRANSPORT IN A COMPUTER NETWORK**
- (75) Inventors: **Alan Lei**, Fremont; **Nitin Karkhanis**, San Francisco; **Richard Livingston**, Hollister; **Uwe Sellentin**, San Jose', all of CA (US)
- (73) Assignee: **Cisco Technology, Inc.**, San Jose, CA (US)
- (*) Notice: Subject to any disclaimer, the term of this patent is extended or adjusted under 35 U.S.C. 154(b) by 0 days.
- (21) Appl. No.: **09/304,395**
- (22) Filed: **May 4, 1999**
- (51) **Int. Cl.⁷** **G06F 13/00**
- (52) **U.S. Cl.** **709/235; 709/232**
- (58) **Field of Search** **709/200-253**

(56) **References Cited**

U.S. PATENT DOCUMENTS

5,331,637 A	7/1994	Francis et al.	370/54
5,353,283 A	10/1994	Tsuchiya	370/60
5,442,633 A	8/1995	Perkins et al.	370/94.1
5,583,996 A	12/1996	Tsuchiya	395/200.15
5,600,644 A	2/1997	Chang et al.	370/404
5,633,866 A	5/1997	Callon	370/397
5,818,842 A	10/1998	Burwell et al.	370/397
5,828,844 A	10/1998	Civanlar et al.	395/200.58
5,898,686 A	4/1999	Virgile	370/381
5,909,441 A	6/1999	Alexander, Jr. et al.	370/395
5,909,550 A	6/1999	Shankar et al.	395/200.57
6,076,114 A	* 6/2000	Wesley	709/235

OTHER PUBLICATIONS

Pearlman, Radia, *Interconnections, Bridges and Routers*, Addison Wesley, 1992, pp. 34-35.
 Tanenbaum, Andrew, *Computer Networks, Second Edition*, 1988, PGS. 253-257.

Comer, Douglas, E., *Internetworking With TCP/IP, 3rd Edition, vol. 1*, Prentice Hall, 1995, pp. 208-216.
 Tanenbaum, Andrew S., "*Computer Networks, 3rd edition*", Prentice Hall, PTR, 1996, pp. 28-54.
 RFC 1795 "IETF", Request For Comments, Informational RFC, RFC 1795, dated Apr., 1995, (www.ietf.org), Section 2.

(List continued on next page.)

Primary Examiner—David Wiley
 (74) *Attorney, Agent, or Firm*—Cesari and McKenna, LLP; A. Sidney Johnston

(57) **ABSTRACT**

A method for computing an ACK timing interval for an ACK timer in a protocol layer LLC type 2 session first measures a time interval between transmission of a frame by a source computer joined to a to a destination computer by an intermediate link, and receipt of a corresponding acknowledgment frame by the source computer from the destination computer. The two events at the source computer, starting a timer upon commencement of transmission of a frame or sequence of frames and the later reception of an acknowledgment message indicating receipt of those frames, permits calculation of a measured time interval. The measured time interval is used to compute the bandwidth of the intermediate link. The required ACK timing interval for the ACK timer is then computed in response to the bandwidth, the number of bytes transmitted after starting the ACK timer, and the return time for an acknowledgment message. The ACK timing interval may be recomputed after every transmission of frames and receipt of a corresponding ACK message. The ACK timing interval is thereby dynamically adjusted to conditions on the intermediate link, including natural bandwidth for either a slow or fast link, congestion due to other traffic on the link, etc. The dynamic adjustment of the ACK timing interval prevents inadvertent timeouts of the ACK timer, and so prevents inadvertent breaking of the LLC type 2 reliable transport connection.

15 Claims, 9 Drawing Sheets

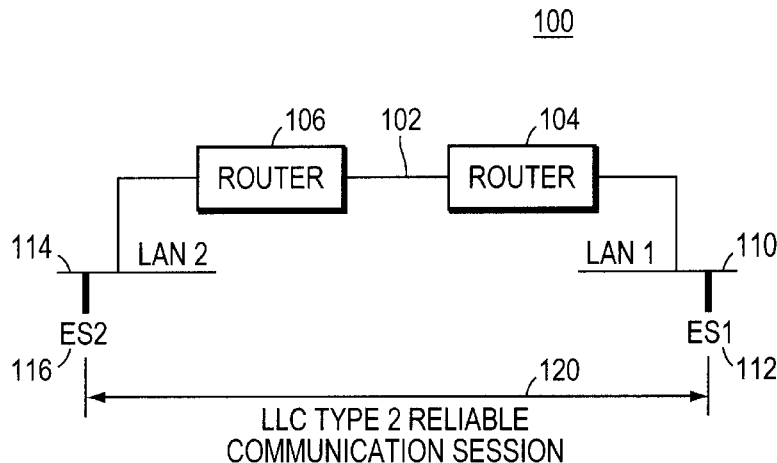

OTHER PUBLICATIONS

Tanenbaum, Andrew, *Computer Networks, 3rd edition*, Prentice Hall, 1996, pp. 28–35, 35–39.
Tanenbaum, Andrew S., *Computer Networks, Second Edition*, Prentice Hall, 1998, pp. 253–268.

Comer, Douglas E., *Computer Networks and Internets*, Prentice Hall, 1997, pp. 239–249.

Comer, Douglas E., *Internetworking with TCP/IP, vol. 1, Third Edition*, Prentice Hall, 1995, pp. 89–107.

* cited by examiner

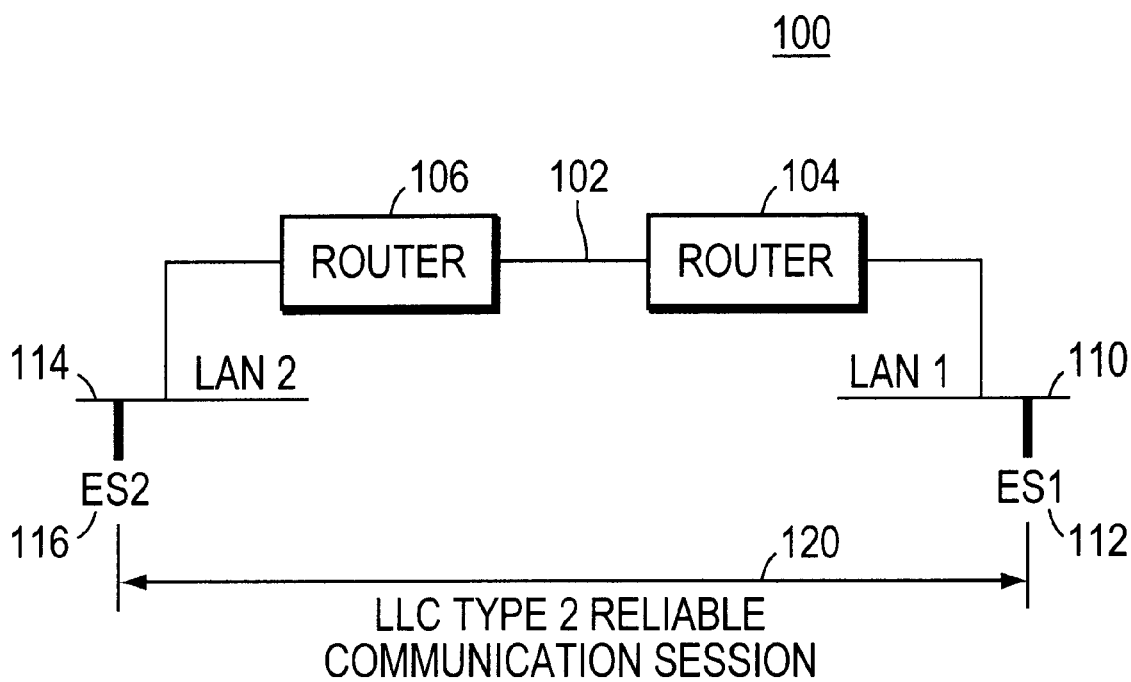

FIG. 1

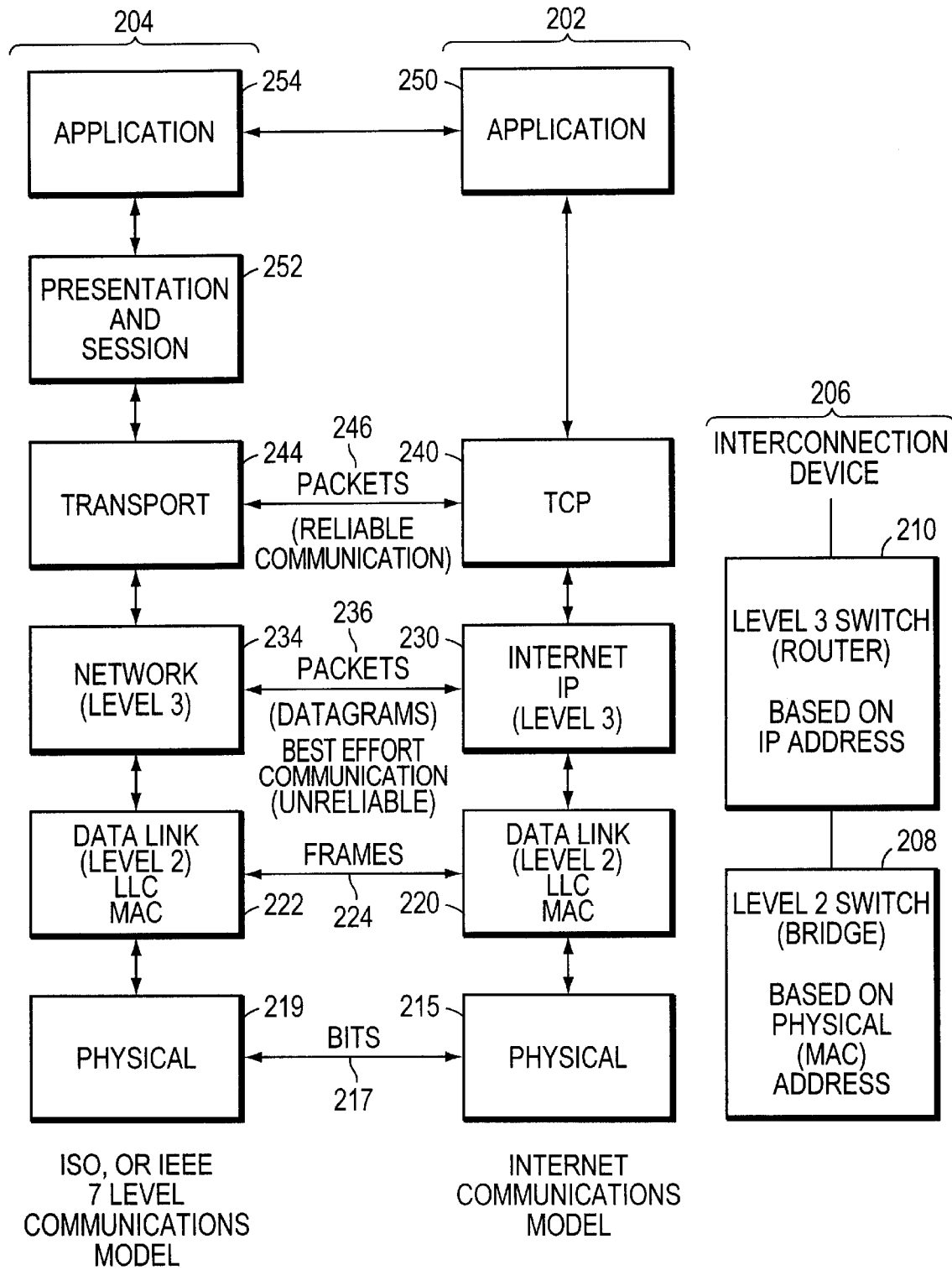

FIG. 2

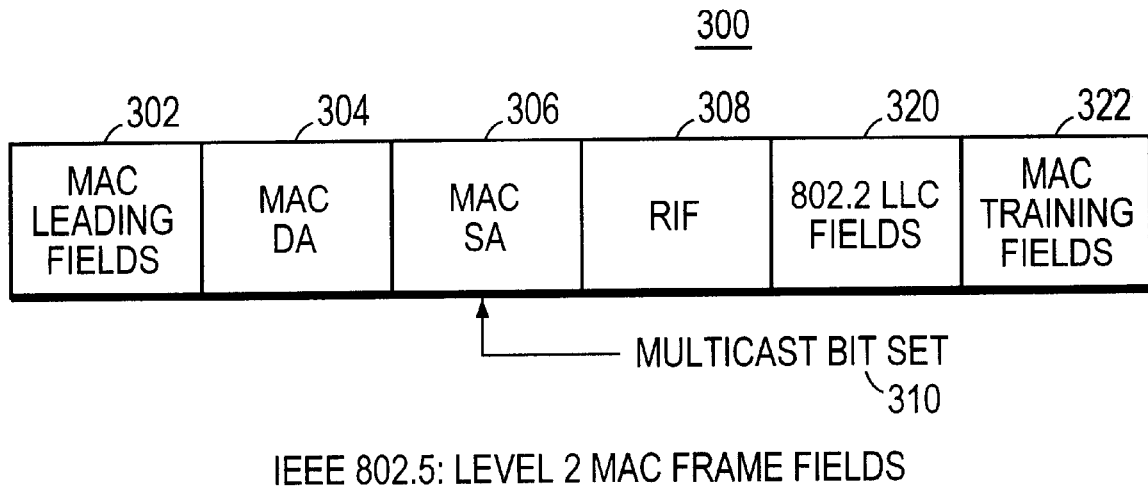

FIG. 3

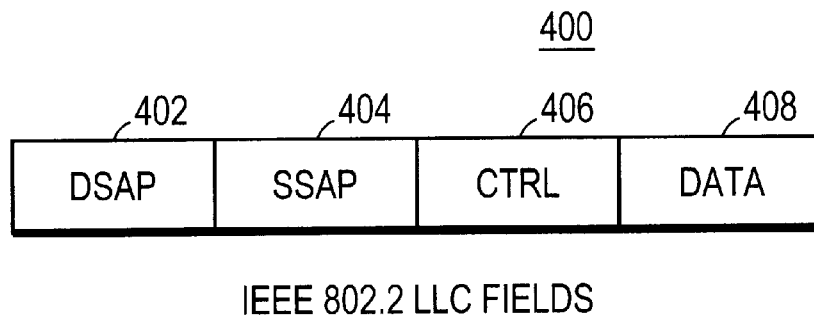

FIG. 4

Explore Litigation Insights

Docket Alarm provides insights to develop a more informed litigation strategy and the peace of mind of knowing you're on top of things.

Real-Time Litigation Alerts



Keep your litigation team up-to-date with **real-time alerts** and advanced team management tools built for the enterprise, all while greatly reducing PACER spend.

Our comprehensive service means we can handle Federal, State, and Administrative courts across the country.

Advanced Docket Research



With over 230 million records, Docket Alarm's cloud-native docket research platform finds what other services can't. Coverage includes Federal, State, plus PTAB, TTAB, ITC and NLRB decisions, all in one place.

Identify arguments that have been successful in the past with full text, pinpoint searching. Link to case law cited within any court document via Fastcase.

Analytics At Your Fingertips



Learn what happened the last time a particular judge, opposing counsel or company faced cases similar to yours.

Advanced out-of-the-box PTAB and TTAB analytics are always at your fingertips.

API

Docket Alarm offers a powerful API (application programming interface) to developers that want to integrate case filings into their apps.

LAW FIRMS

Build custom dashboards for your attorneys and clients with live data direct from the court.

Automate many repetitive legal tasks like conflict checks, document management, and marketing.

FINANCIAL INSTITUTIONS

Litigation and bankruptcy checks for companies and debtors.

E-DISCOVERY AND LEGAL VENDORS

Sync your system to PACER to automate legal marketing.