

# Gigabit Ethernet Technical Brief

---

**Achieving End-to-End Performance**



ALTEON  
NETWORKS

Alteon Networks, Inc.  
6351 San Ignacio Avenue  
San Jose, CA 95119

1-408-574-5500

First Edition  
September 1996

© 1996 by Alteon Networks, Inc. All rights reserved.

# Contents

---

## **Gigabit Ethernet Technical Brief Achieving End-to-End Performance**

Goals of Gigabit Ethernet	1
Uses of Gigabit Ethernet	2
Gigabit Ethernet History	3
Gigabit Ethernet Momentum	4
Workstation Speed	4
Desktop Multimedia	5
Multivendor Interoperability	6
Migrating to Gigabit Ethernet	6
Gigabit Ethernet Components	6
Upgrade Scenarios	6
Upgrading Connections to Centralized File and Compute Servers	7
Upgrading Connections between Switches	8
Upgrading a Switched Fast Ethernet Backbone	8
Upgrading a Shared FDDI Backbone	9
Protocol Architecture	10
Physical Interface Characteristics	11
Serializer/Deserializer	11
8B/10B Encoding	11
MAC Layer	11
Upper Layers	11
Cabling types and distances	12
Flow Control	12
Full-Duplex Transmission	12
Half-duplex Transmission	13
Carrier Extension	14
Technology Advances	15
First Generation Ethernet Adapters	16
Second Generation Ethernet Adapters	17
Third Generation Ethernet Adapters—The Alteon Difference	18
Conclusion	20

# Gigabit Ethernet Technical Brief

## Achieving End-to-End Performance

Intranet Web servers, centralized file and compute servers, data warehousing, groupware, medical imaging, CAD/CAM applications, 3-D modeling, animation, video, pre-press applications, server farms, seismic processing...

The list goes on and on. The demand for high-speed network connections is proliferating at a pace almost as rapid as the speed requirements of the applications themselves. Evidence is everywhere: the rapid acceptance of 10/100 Mbps connections on today's desktop computers, Ethernet switching at the department level, and the deployment of Fast Ethernet switches in corporate backbones are a few examples of the need for faster and faster networks.

And still, bottlenecks remain. Server network connections have been limited to 100 Mbps since FDDI was shipping in volume in the late 1980's. Fast Ethernet made it easier to build internetworking products, but did not provide a faster server interface. Today, centralized servers are often configured with multiple 100 Mbps network connections to meet bandwidth requirements.

Enter Gigabit Ethernet.

Gigabit Ethernet is a new technology that will provide seamless interoperability with Ethernet and Fast Ethernet. Gigabit Ethernet transfers data at a blazingly fast speed: one gigabit per second, or 100 times the rate of standard Ethernet. Gigabit Ethernet is designed to deliver the same benefits as Fast Ethernet: seamless integration with installed Ethernets, dramatically higher performance than the previous standard, and a familiar management environment.

It couldn't happen at a better time. Multimedia over IP is just starting to take off with the proposed IETF standards, real-time transfer protocol (RTP) and resource reservation protocol (RSVP). These protocols, combined with gigabit networks, high-performance desktops, and Internet technology, will quickly change the way corporations access information.

Ethernet. Fast Ethernet. Gigabit Ethernet. Networking made simple!

### Goals of Gigabit Ethernet

Under development in the IEEE by the 802.3z Task Force, Gigabit Ethernet has the following primary goals:

- Complete interoperability with Ethernet and Fast Ethernet
  - Retain the installed base of NICs
  - Leverage the investment in hubs, switches, and routers
  - Leverage the network management environment

- Conform to the Ethernet standard
  - Frame format
  - Minimum and maximum frame sizes
  - CSMA/CD access method
  - 802.2 LLC specifications
- Provide a simple forwarding mechanism between 10, 100, and 1000 Mbps
  - No fragmentation of frames
  - No encapsulation of frames
  - No translation of frames
- Provide 10 times the performance of Fast Ethernet

## Uses of Gigabit Ethernet

Initially, Gigabit Ethernet will be deployed in three key areas:

- Aggregating traffic between Ethernet clients and centralized file or compute servers
- Connecting multiple 100Base-T Fast Ethernet switches through 100/1000 Mbps switches
- Connecting both workstations and servers with Gigabit Ethernet to run high-bandwidth applications, such as CAD/CAM, medical imaging, and pre-press

Figure 1 illustrates the projected initial uses of Gigabit Ethernet.

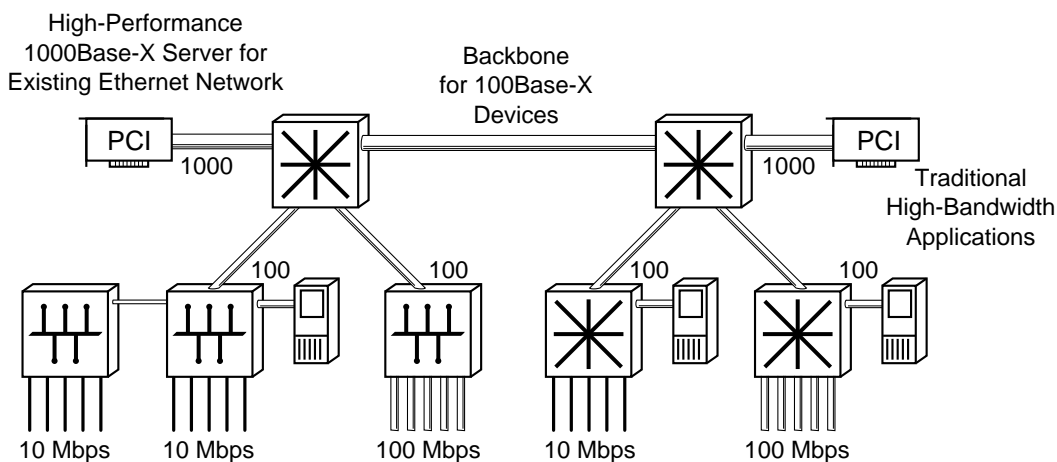

**Figure 1. Initial deployment of Gigabit Ethernet**

In the future, the uses of Gigabit Ethernet will be extended to incorporate switches based entirely on Gigabit Ethernet on the campus backbone, centralized server farms connected to these all-gigabit switches, and specialized high-performance client workstations. Figure 2 illustrates some future Gigabit Ethernet possibilities.

# Explore Litigation Insights

Docket Alarm provides insights to develop a more informed litigation strategy and the peace of mind of knowing you're on top of things.

## Real-Time Litigation Alerts



Keep your litigation team up-to-date with **real-time alerts** and advanced team management tools built for the enterprise, all while greatly reducing PACER spend.

Our comprehensive service means we can handle Federal, State, and Administrative courts across the country.

## Advanced Docket Research



With over 230 million records, Docket Alarm's cloud-native docket research platform finds what other services can't. Coverage includes Federal, State, plus PTAB, TTAB, ITC and NLRB decisions, all in one place.

Identify arguments that have been successful in the past with full text, pinpoint searching. Link to case law cited within any court document via Fastcase.

## Analytics At Your Fingertips



Learn what happened the last time a particular judge, opposing counsel or company faced cases similar to yours.

Advanced out-of-the-box PTAB and TTAB analytics are always at your fingertips.

## API

Docket Alarm offers a powerful API (application programming interface) to developers that want to integrate case filings into their apps.

## LAW FIRMS

Build custom dashboards for your attorneys and clients with live data direct from the court.

Automate many repetitive legal tasks like conflict checks, document management, and marketing.

## FINANCIAL INSTITUTIONS

Litigation and bankruptcy checks for companies and debtors.

## E-DISCOVERY AND LEGAL VENDORS

Sync your system to PACER to automate legal marketing.