

UNITED STATES PATENT AND TRADEMARK OFFICE

BEFORE THE PATENT TRIAL AND APPEAL BOARD

AT&T SERVICES, INC.,
Petitioner,

v.

VOIP-PAL.COM, INC.,
Patent Owner.

Case IPR2017-01383
Patent 9,179,005 B2

Before JOSIAH C. COCKS, JENNIFER MEYER CHAGNON, and
JOHN A. HUDALLA, *Administrative Patent Judges*.

CHAGNON, *Administrative Patent Judge*.

DECISION
Denying Institution of *Inter Partes* Review
37 C.F.R. § 42.108

I. INTRODUCTION

AT&T Services, Inc. (“Petitioner”)¹ filed a Petition for *inter partes* review of claims 74–79, 83, 84, 88, 89, 92, 94–96, 98, and 99 (“the challenged claims”) of U.S. Patent No. 9,179,005 B2 (Ex. 1001, “the ’005 patent”). Paper 1 (“Pet.”). Petitioner relies on the Declaration of James Bress (Ex. 1003) to support its positions. Voip-Pal.com, Inc. (“Patent Owner”)² filed a Preliminary Response. Paper 5 (“Prelim. Resp.”).

We have authority to determine whether to institute *inter partes* review. *See* 35 U.S.C. § 314(b); 37 C.F.R. § 42.4(a). Upon consideration of the Petition and the Preliminary Response, and for the reasons explained below, we determine that the information presented does not show a reasonable likelihood that Petitioner would prevail with respect to any of the challenged claims. *See* 35 U.S.C. § 314(a). Accordingly, no trial is instituted.

A. *Related Proceedings*

The parties indicate that the ’005 patent is the subject of the following district court proceedings: *Voip-Pal.com, Inc. v. Verizon Wireless Services, LLC & AT&T Corp.*, Case No. 2:16-cv-00271 (D. Nev.); *Voip-Pal.com, Inc. v. Apple, Inc.*, 2-16-cv-00260 (D. Nev.); and *Voip-Pal.com, Inc. v. Twitter, Inc.*, 2-16-cv-02338 (D. Nev.). Pet. 2; Paper 4, 1.

Petitioner concurrently filed a petition for *inter partes* review of other claims of the ’005 patent. Pet. 2; Paper 4, 1; *AT&T Services, Inc. v.*

¹ Petitioner identifies several additional entities as real parties-in-interest. *See* Pet. 1–2.

² Patent Owner identifies Digifonica (International) Limited as an additional real party-in-interest. Paper 4, 1.

IPR2017-01383
Patent 9,179,005 B2

Voip-Pal.com, Inc., Case IPR2017-01384. Petitioner also filed a petition for *inter partes* review of related U.S. Patent No. 8,542,815 B2 (“the ’815 patent”). Paper 4, 1; *AT&T Services, Inc. v. Voip-Pal.com, Inc.*, Case IPR2017-01382.

The parties also identify the following proceedings, filed by Apple, Inc., to which Petitioner is not a party:

IPR2016-01198, challenging the ’005 patent;
IPR2016-01201, challenging the ’815 patent;
IPR2017-01398, challenging the ’005 patent;
IPR2017-01399, challenging the ’815 patent.

Pet. 3; Paper 4, 1.

B. The ’005 Patent

The ’005 patent is titled “Producing Routing Messages for Voice Over IP Communications.” Ex. 1001, at [54]. In particular, the ’005 patent relates to producing a routing message for routing calls in a communication system, where the routing message is based on call classification criteria that are used to classify a particular call as a public network call or a private network call. Ex. 1001, at [57]. Figure 7 of the ’005 patent is reproduced below.

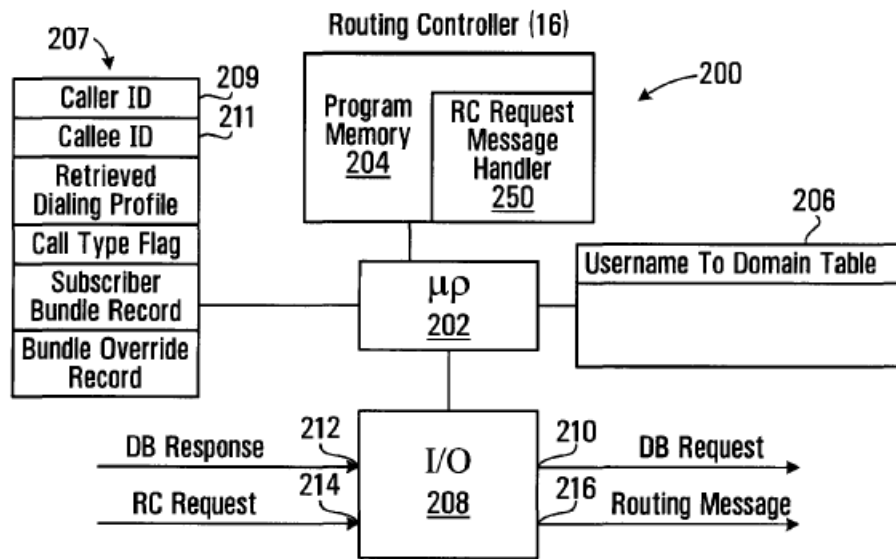

FIG. 7

Figure 7, reproduced above, illustrates routing controller (RC) 16, which facilitates communication between callers and callees. *Id.* at 14:32–33, 17:26–27. RC processor circuit 200 of routing controller (RC) 16 includes processor 202, program memory 204, table memory 206, buffer memory 207, and I/O port 208. *Id.* at 17:27–31. Routing controller 16 queries database 18 (shown in Figure 1) to produce a routing message to connect caller and callee. *Id.* at 14:18–25, 14:32–42. Program memory 204 includes blocks of code for directing processor 202 to carry out various functions of routing controller 16. *Id.* at 17:47–49. One such block of code is RC request message handler 250, which directs routing controller 16 to produce a routing message in response to an RC request message. *Id.* at 17:49–53.

According to the '005 patent, in response to a calling subscriber initiating a call, the routing controller:

receiv[es] a callee identifier from the calling subscriber, us[es] call classification criteria associated with the calling subscriber to classify the call as a public network call or a private network call[,] and produc[es] a routing message identifying an address on the private network, associated with the callee[,] when the call is classified as a private network call and produc[es] a routing message identifying a gateway to the public network when the call is classified as a public network call.

Id. at 14:32–42.

Figures 8A through 8D of the '005 patent illustrate a flowchart of an RC request message handler process, executed by the RC processor circuit.

Id. at 11:3–4. Figure 8B of the '005 patent is reproduced below.

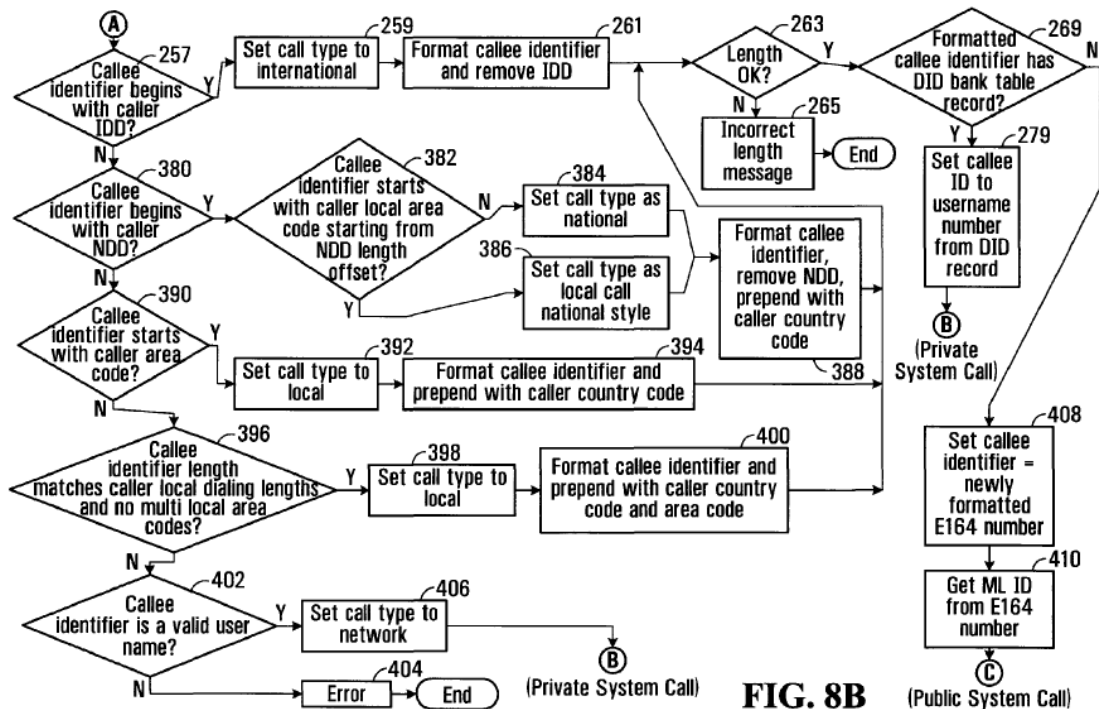

Figure 8B, reproduced above, illustrates a portion of the RC request message handler process, and in particular illustrates steps for performing checks on

Explore Litigation Insights

Docket Alarm provides insights to develop a more informed litigation strategy and the peace of mind of knowing you're on top of things.

Real-Time Litigation Alerts



Keep your litigation team up-to-date with **real-time alerts** and advanced team management tools built for the enterprise, all while greatly reducing PACER spend.

Our comprehensive service means we can handle Federal, State, and Administrative courts across the country.

Advanced Docket Research



With over 230 million records, Docket Alarm's cloud-native docket research platform finds what other services can't. Coverage includes Federal, State, plus PTAB, TTAB, ITC and NLRB decisions, all in one place.

Identify arguments that have been successful in the past with full text, pinpoint searching. Link to case law cited within any court document via Fastcase.

Analytics At Your Fingertips



Learn what happened the last time a particular judge, opposing counsel or company faced cases similar to yours.

Advanced out-of-the-box PTAB and TTAB analytics are always at your fingertips.

API

Docket Alarm offers a powerful API (application programming interface) to developers that want to integrate case filings into their apps.

LAW FIRMS

Build custom dashboards for your attorneys and clients with live data direct from the court.

Automate many repetitive legal tasks like conflict checks, document management, and marketing.

FINANCIAL INSTITUTIONS

Litigation and bankruptcy checks for companies and debtors.

E-DISCOVERY AND LEGAL VENDORS

Sync your system to PACER to automate legal marketing.