

- [54] **METHOD AND APPARATUS FOR POINTING TUBES** 397,343 8/1933 Great Britain.....72/367
35,625 4/1955 Poland.....72/402
- [72] Inventor: **Arthur H. Tuberman**, 4527 W. 170th St., Lawndale, Calif. 90260
- [22] Filed: **Aug. 26, 1970**
- [21] Appl. No.: **67,007**
- [52] U.S. Cl.72/402, 72/452
- [51] Int. Cl.**B21d 41/04**
- [58] Field of Search.....72/402, 367, 369, 399, 400, 72/410, 452, 468, 469, 470, 472; 18/DIG. 5

Primary Examiner—Charles W. Lanham
Assistant Examiner—Gene P. Crosby
Attorney—Fulwider, Patton, Rieber, Lee & Utecht

[57] **ABSTRACT**

Method and apparatus for forming a generally cylindrical point on a tube by first flattening the tube from at least three sides to a polygonal cross section while forming curved sections between the flat sides, and then progressively contracting the tube to bring the curved sections together while buckling the flat sides inwardly into loops that are flattened inside the point. At least three die shoes arranged around a die recess in alternately overlapping relation have flat inner faces with an elongated lip along one side for shaping the curved sections, and also have flat, inclined bevels for shaping the transition zone of the tube during pointing, each bevel having a part-conical lip on one side for the final shaping of the transition zone to a conical shape. One actuating arrangement utilizes a mutual camming action to move all die shoes simultaneously at the same rate to maintain the point on a preselected axis, while a simpler form displaces the axis during pointing.

16 Claims, 27 Drawing Figures

- [56] **References Cited**
- UNITED STATES PATENTS**
- | | | | |
|-----------|---------|---------------|--------|
| 3,478,565 | 11/1969 | Schenk..... | 72/399 |
| 2,589,142 | 3/1952 | Rotheroe..... | 72/400 |
| 3,068,929 | 12/1962 | Rowell..... | 72/400 |
| 3,292,414 | 12/1966 | Goeke..... | 72/402 |
| 3,417,598 | 12/1968 | Valente..... | 72/383 |
| 3,509,785 | 5/1970 | Fuchs..... | 72/347 |
- FOREIGN PATENTS OR APPLICATIONS**
- | | | | |
|-----------|--------|--------------------|-----------|
| 372,543 | 5/1932 | Great Britain..... | 72/367 |
| 449,558 | 9/1927 | Germany..... | 72/402 |
| 1,035,352 | 4/1955 | Germany..... | 18/DIG. 5 |

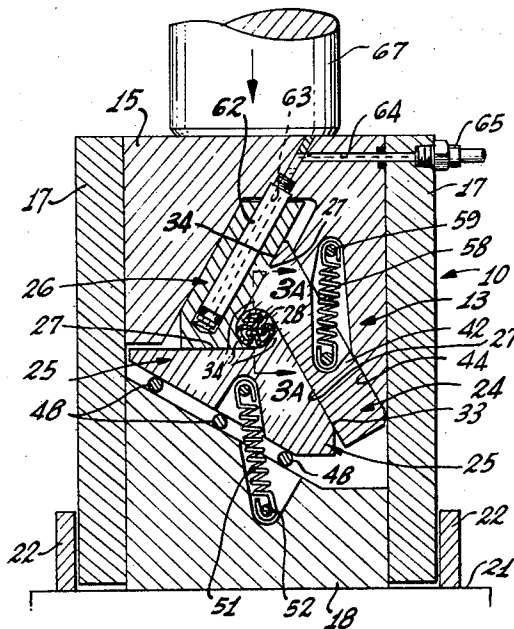

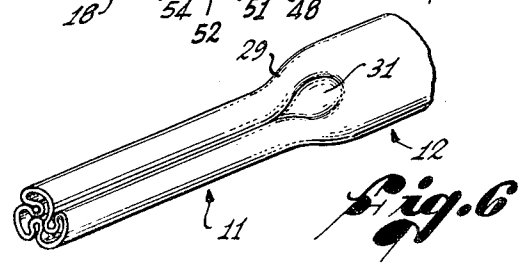
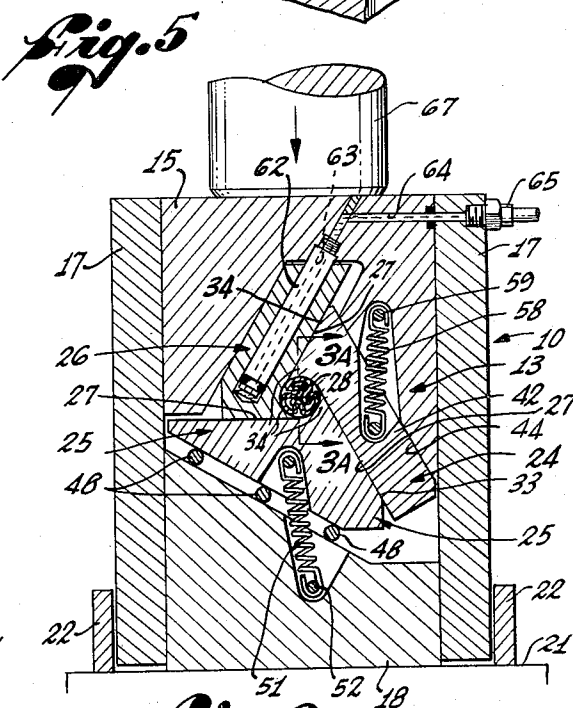
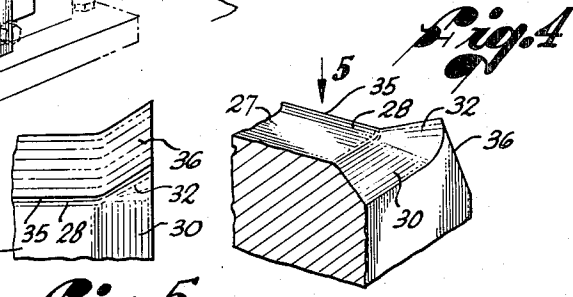
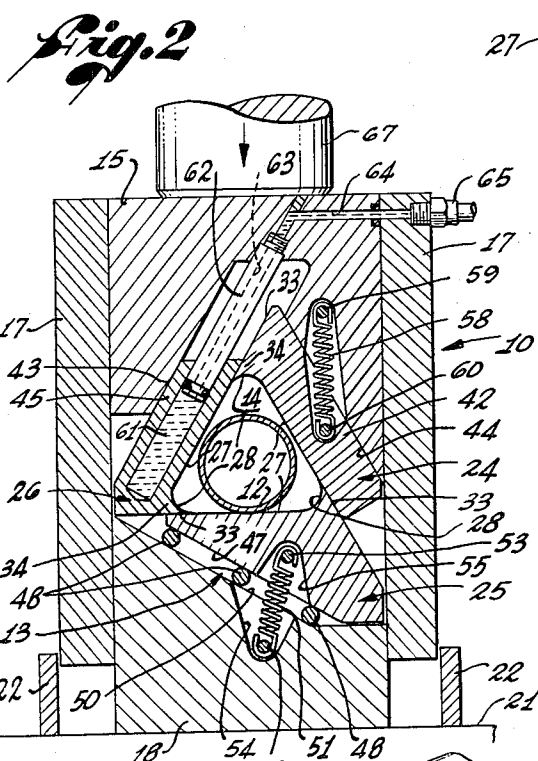
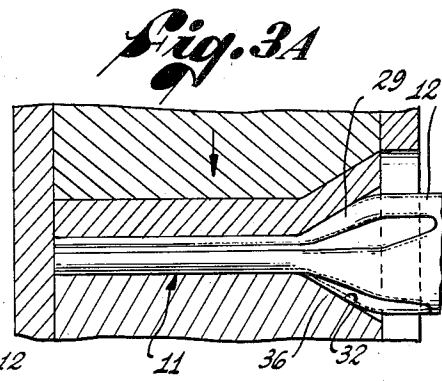
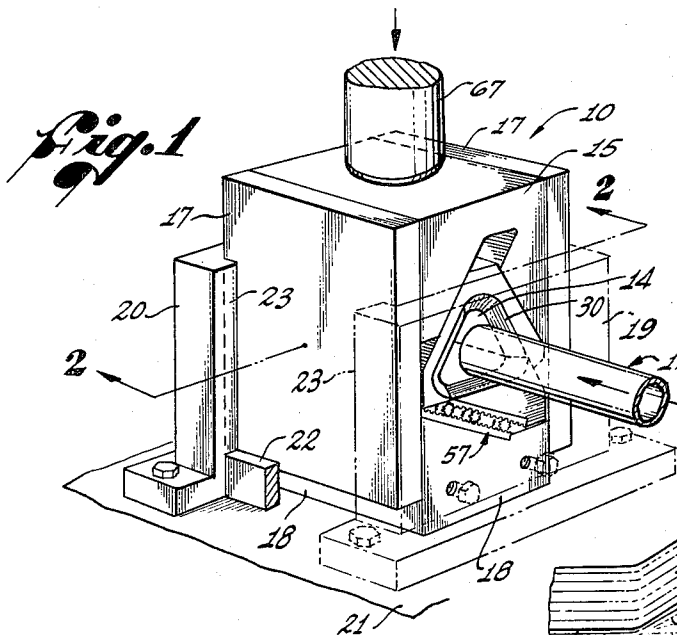

INVENTOR
 ARTHUR H. TUBERMAN
 BY Fulwider, Patton, Rieber,
 Lee, and Uecht
 ATTORNEYS

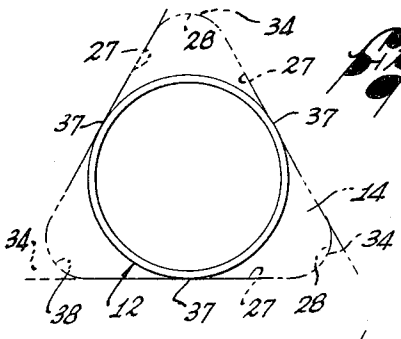

Fig. 7

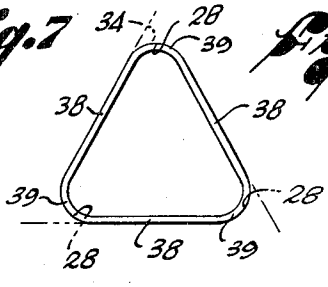

Fig. 8

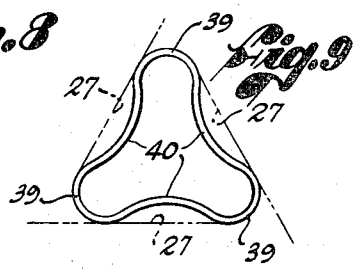

Fig. 9

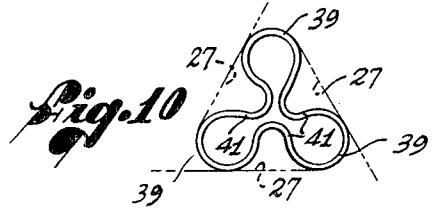

Fig. 10

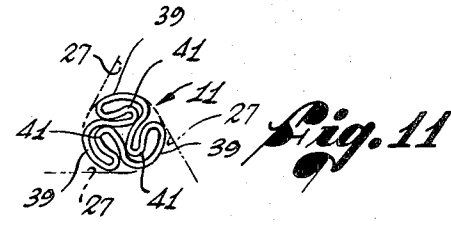

Fig. 11

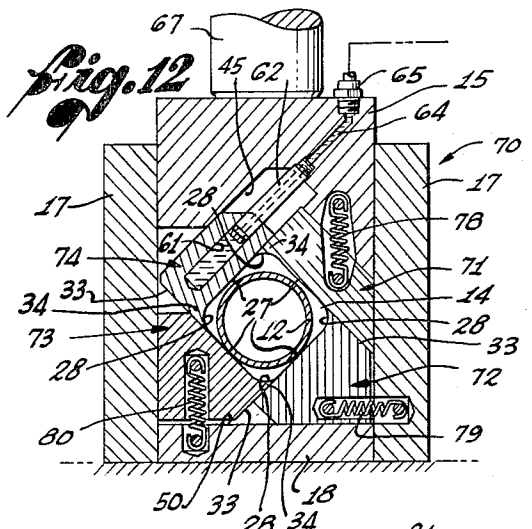

Fig. 12

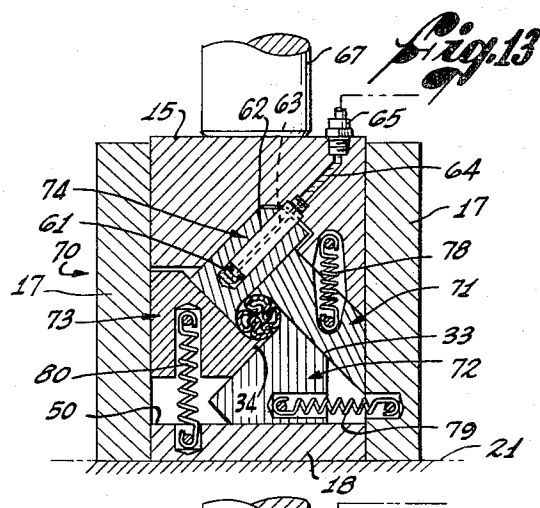

Fig. 13

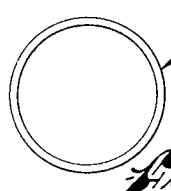

Fig. 15

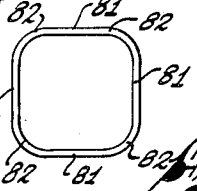

Fig. 16

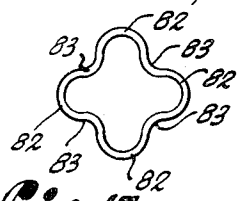

Fig. 17

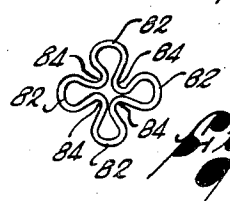

Fig. 18

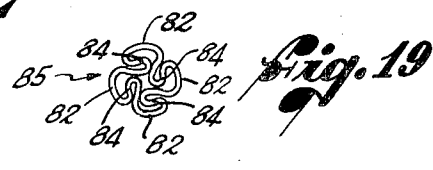

Fig. 19

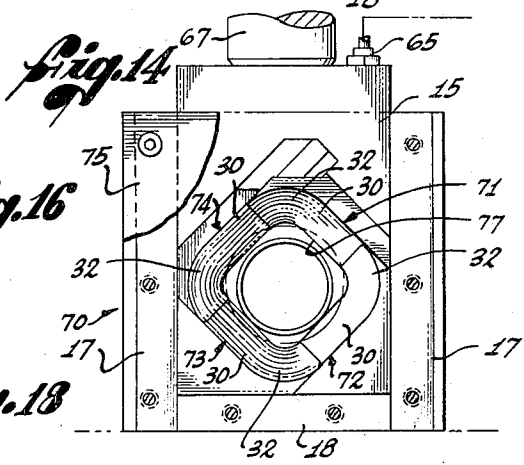

Fig. 14

INVENTOR.
 ARTHUR H. TUBERMAN
 BY *Fulwider, Patton, Kiehn,
 Lee, and Uecht*

ATTORNEYS

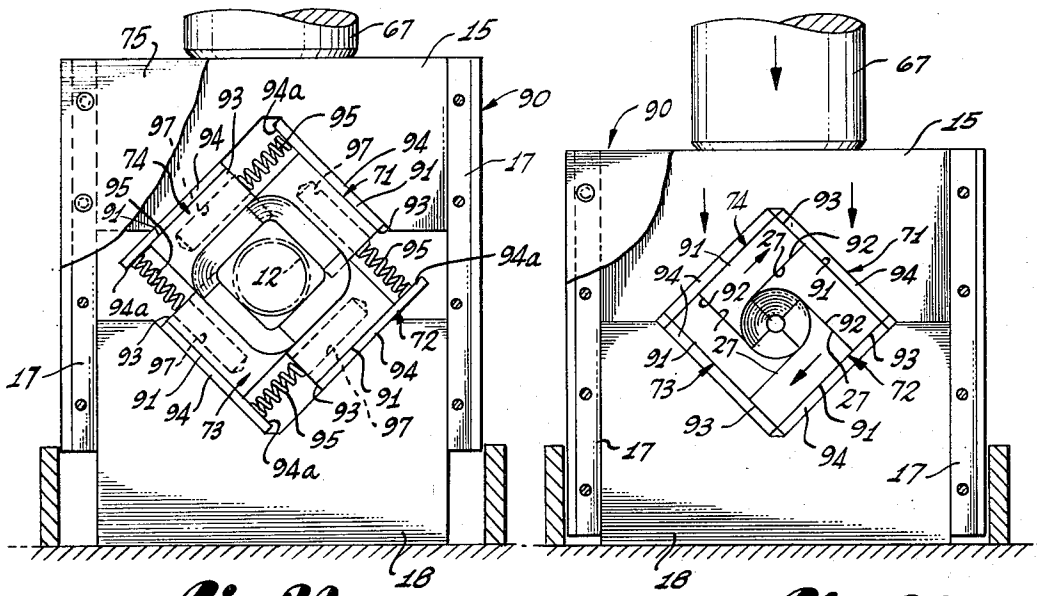

Fig. 20

Fig. 21

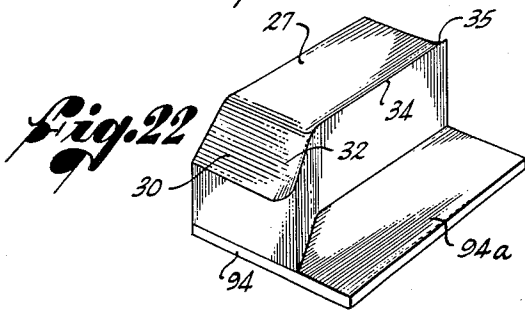

Fig. 22

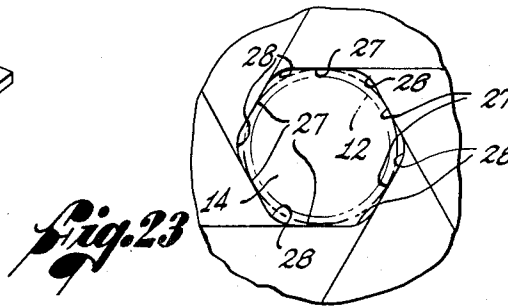

Fig. 23

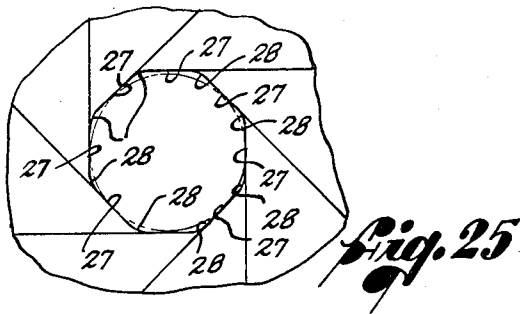

Fig. 25

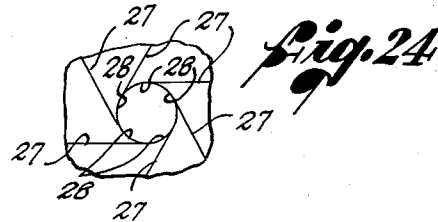

Fig. 24

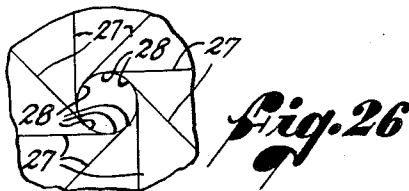

Fig. 26

INVENTOR.
 ARTHUR H. TUBERMAN
 BY *Fulwider, Patton, Rieber*
& Co. and Nach
 ATTORNEYS

METHOD AND APPARATUS FOR POINTING TUBES

BACKGROUND OF THE INVENTION

This invention relates to the forming of reduced-diameter end portions on tubes for use in gripping the tubes during an operation such as drawing through a die. Such reduced-diameter end portions (called "points" although they typically are generally cylindrical or have some other blunt-ended shape) are necessary because the original tubing to be drawn through the die has a larger outside diameter than the diameter of the die, and also to provide a portion of the tube that can be gripped securely to apply the drawing force.

Tube pointing machines of various types are known and have been used by the trade. For example, U.S. Pat. No. 3,292,414 shows an apparatus for swaging points with a plurality of arcuate reciprocating die segments which compress a tube as the arcuate faces of the dies are pressed together around the tube. Rotary swaging also has been used. In another, somewhat similar approach, represented by U.S. Pat. No. 3,073,374, a tube is positioned between two dies having semi-cylindrical, concave faces and is pinched and pleated from opposite sides before the semi-cylindrical dies are closed around the tube.

In still another approach, shown in U.S. Pat. No. 3,068,929, a tube is positioned over an open-sided, part polygonal recess and then forced into the recess by two rams which, when moved toward the open side of the recess, compress the tube into the recess and cooperate therewith to form a regular polygonal cavity in which the tube is collapsed and compacted to the desired shape. A similar result is obtained by the pointer shown in U.S. Pat. No. 3,417,598 in which four dies arranged around the end of a tube are formed with interleaved flat-edged ribs which permit the dies to be moved together to crush the end portion of the tube into a point.

While these and other known pointers are capable of producing usable points on tubes, all of the pointers presently available are subject to one or more deficiencies that have prevented the achievement of optimum results. Specifically, many of the machines produce an excessively high noise level as an incident to the pointing operation, or require rather complicated and difficult-to-maintain machinery. More importantly, despite claims that points can be formed completely in one stroke, it often is necessary to repeat the forming stroke several times in order to obtain a proper point, probably because most of the die systems inherently include gaps into which the metal can be displaced during pointing. At the same time, it is difficult, if at all possible, to obtain uniformity in point diameters while maintaining the points concentric with the tubes.

The configuration of the transition zone between the point and the body of the tube is particularly important from the standpoint of performance of the tube during subsequent drawing operations. If the tube is folded with nonuniform convolutions or distinct creases, particularly in the transition zone, as is common in some of the prior pointers, stress risers are set up and can result in cracks which propagate down the tube during the

Moreover, many tube materials are "notch sensitive," that is, tend to break under stress wherever a notch or groove has been formed during pointing. Thus, any pointer which notches the tube during pointing, particularly in or around the transition zone, produces a likelihood of failure during subsequent operations. Of course, ruggedness, durability and relative simplicity of construction, as well as economy in construction, operation and maintenance, are primary objects of any production machine, and certain of the prior art machines, such as those requiring interleaved ribs, are deficient in these respects.

SUMMARY OF THE INVENTION

The present invention resides in an improved tube pointer which produces superior and uniform points in a novel manner by positively guiding and controlling the bending of the tube material at all times, both in the zone of the point and in the transition zone, while eliminating gaps in the die apparatus that could result in uncontrolled bending or objectionable displacement of the tube wall. Moreover, the tube pointer of the invention is capable of forming such points in a single and rapid one-stroke operation, is relatively simple, durable and quiet in operation, avoids cracks and objectionable creases in the transition area, and can maintain the point precisely concentric with the tube, thereby avoiding the disadvantages or prior pointers.

To the foregoing ends, the pointer includes a die having at least three die shoes that are arranged around and define an open-ended die recess of generally polygonal cross section and are interfitted to permit the shoes to move inwardly and outwardly, radially of the tube, to contract and expand the recess, the shoes having substantially flat inner working faces which form the tube first into a generally polygonal cross-sectional shape as the shoes move inwardly to contract the recess. The shoes also include means for shaping the tube between the sides of the polygonal cross section into arcuate sections so that continued inward movement of the shoes progressively shortens the sides of the polygonal cross section to buckle and fold the sides inwardly while moving the arcuate sections toward each other, finally squeezing the arcuate sections substantially together into a generally cylindrical point with the buckled portions formed as flattened loops within the point.

Controlled formation of the transition zone of the tube is accomplished by substantially flat bevels on the die shoes which have the same slope away from the working faces as the desired angle of the cone of the transition zone, the bevels also having means thereon for closing conically around the transition zone as the arcuate sections of the point are brought together. The controlled buckling of the point zone and the controlled sinking of the bevels into the tube cooperate to form uniform folds or convolutions in the transition zone with soft creases that flare from the point toward the tube into wide and gently rounded ends at the junction with the tube.

To permit such progressive contraction of die shoes having flat working faces, the shoes are arranged in alternately overlapped relation so that an edge of one shoe slides along the working face of one adjacent

Explore Litigation Insights

Docket Alarm provides insights to develop a more informed litigation strategy and the peace of mind of knowing you're on top of things.

Real-Time Litigation Alerts



Keep your litigation team up-to-date with **real-time alerts** and advanced team management tools built for the enterprise, all while greatly reducing PACER spend.

Our comprehensive service means we can handle Federal, State, and Administrative courts across the country.

Advanced Docket Research



With over 230 million records, Docket Alarm's cloud-native docket research platform finds what other services can't. Coverage includes Federal, State, plus PTAB, TTAB, ITC and NLRB decisions, all in one place.

Identify arguments that have been successful in the past with full text, pinpoint searching. Link to case law cited within any court document via Fastcase.

Analytics At Your Fingertips



Learn what happened the last time a particular judge, opposing counsel or company faced cases similar to yours.

Advanced out-of-the-box PTAB and TTAB analytics are always at your fingertips.

API

Docket Alarm offers a powerful API (application programming interface) to developers that want to integrate case filings into their apps.

LAW FIRMS

Build custom dashboards for your attorneys and clients with live data direct from the court.

Automate many repetitive legal tasks like conflict checks, document management, and marketing.

FINANCIAL INSTITUTIONS

Litigation and bankruptcy checks for companies and debtors.

E-DISCOVERY AND LEGAL VENDORS

Sync your system to PACER to automate legal marketing.