



US005437083A

United States Patent [19]

[11] Patent Number: **5,437,083**

Williams et al.

[45] Date of Patent: **Aug. 1, 1995**

[54] STENT-LOADING MECHANISM

[75] Inventors: **Michael S. Williams**, Chapel Hill, N.C.; **Lilip Lau**, Sunnyvale, Calif.; **Farhad Khosravi**, Belmont, Calif.; **William Hartigan**, Fremont, Calif.; **Avegel Hernando**, Union City, Calif.

[73] Assignee: **Advanced Cardiovascular Systems, Inc.**, Santa Clara, Calif.

[21] Appl. No.: **66,707**

[22] Filed: **May 24, 1993**

[51] Int. Cl.⁶ **B23P 19/02; A61B 17/00**

[52] U.S. Cl. **29/235; 606/1**

[58] Field of Search **29/235, 234, 282, 283; 269/164; 606/151, 201, 1**

[56] References Cited

U.S. PATENT DOCUMENTS

696,289 3/1902 Williams 29/235
5,189,786 3/1993 Ishikawa et al. 29/285

FOREIGN PATENT DOCUMENTS

159065 2/1921 United Kingdom 269/164

Primary Examiner—Tamara L. Graysay
Attorney, Agent, or Firm—Fulwider Patton Lee & Utecht

[57] ABSTRACT

A stent-loading mechanism for loading a stent onto a balloon delivery catheter of the kind typically used in typical percutaneous transluminal coronary angioplasty (PTCA) procedures.

The device comprises a series of plates having substantially flat and parallel surfaces that move in a rectilinear fashion with respect to each another. A stent carrying catheter can be disposed between these surfaces to affix the stent onto the outside of the catheter by relative motion between the plates. The plates have multiple degrees of freedom and may have force-indicating transducers to measure and indicate the force applied to the catheter during affixation of the stent.

13 Claims, 3 Drawing Sheets

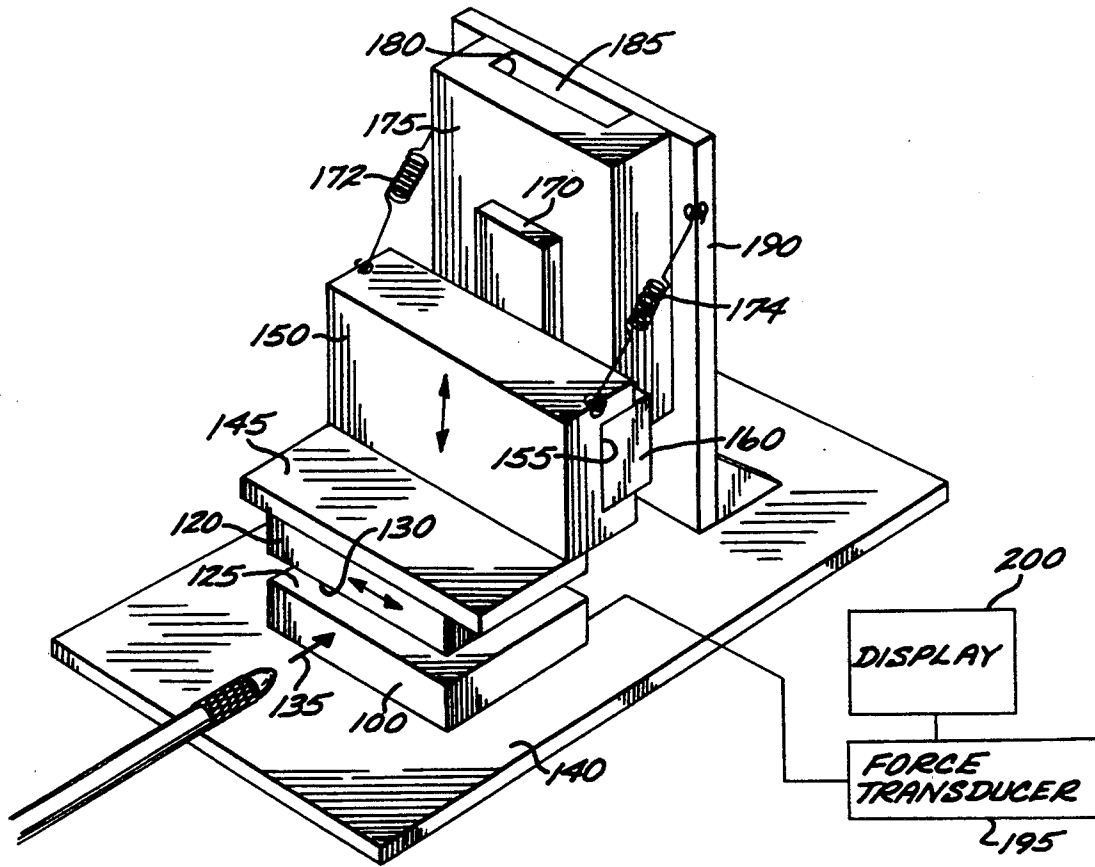

EDWARDS LIFESCIENCES EX 1007

FIG. 1

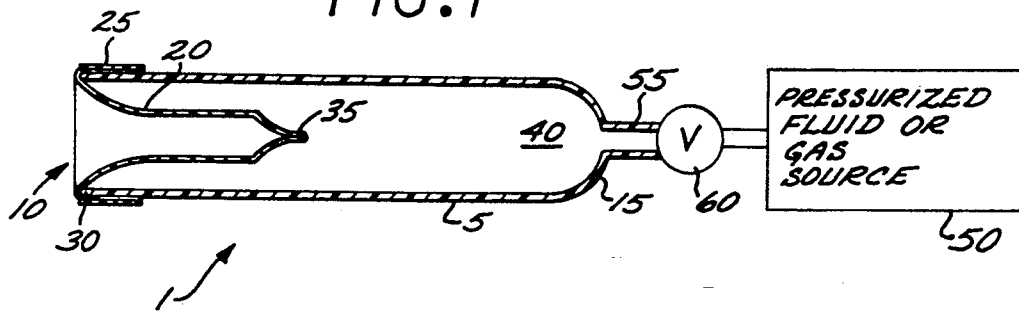

FIG. 2

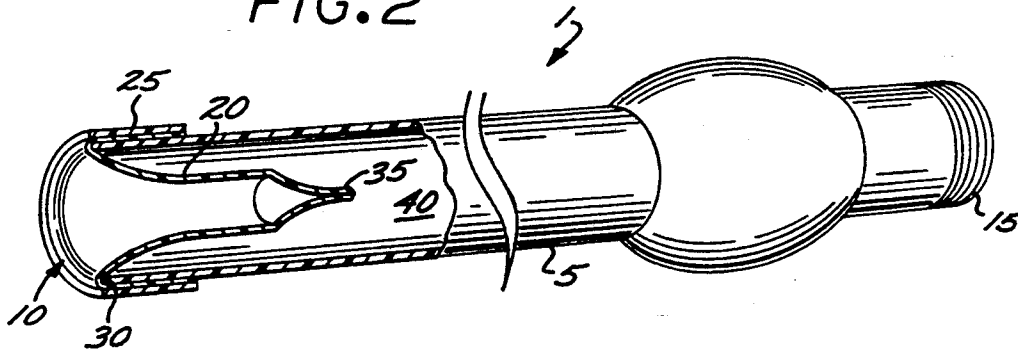

FIG. 3

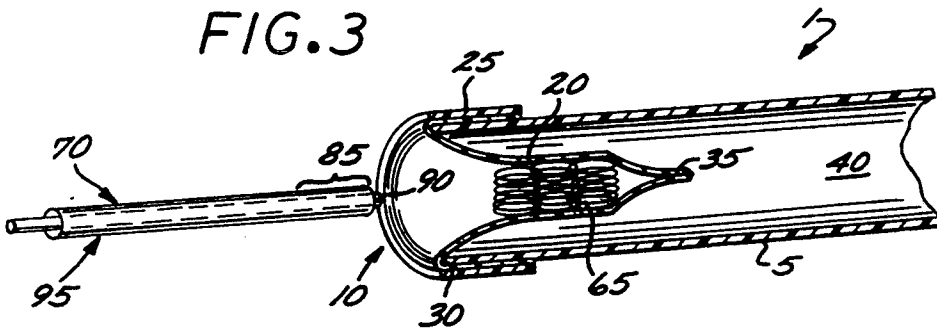
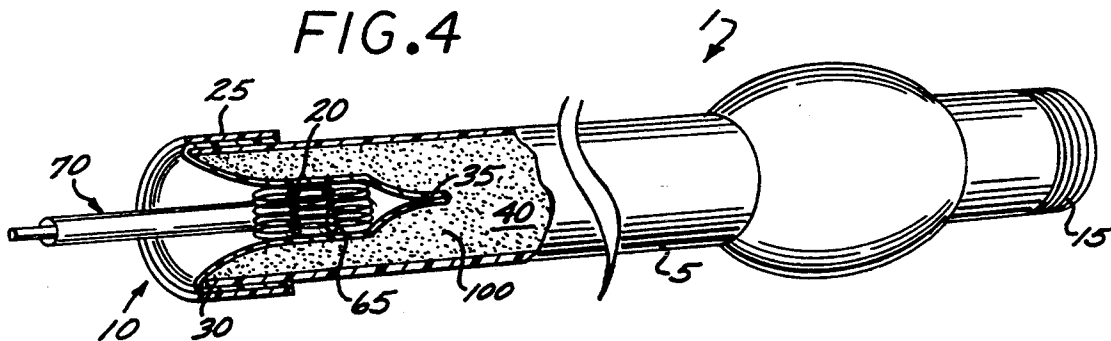

FIG. 4



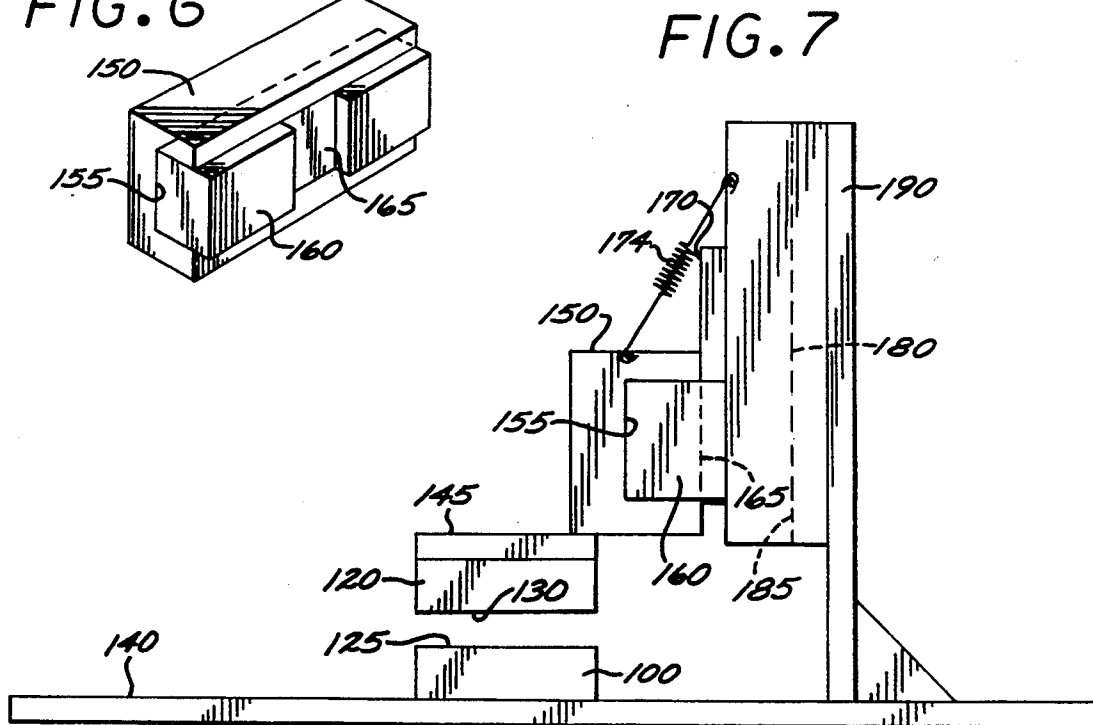
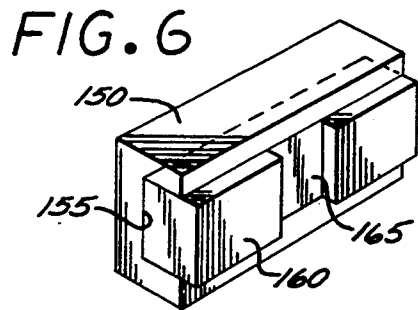
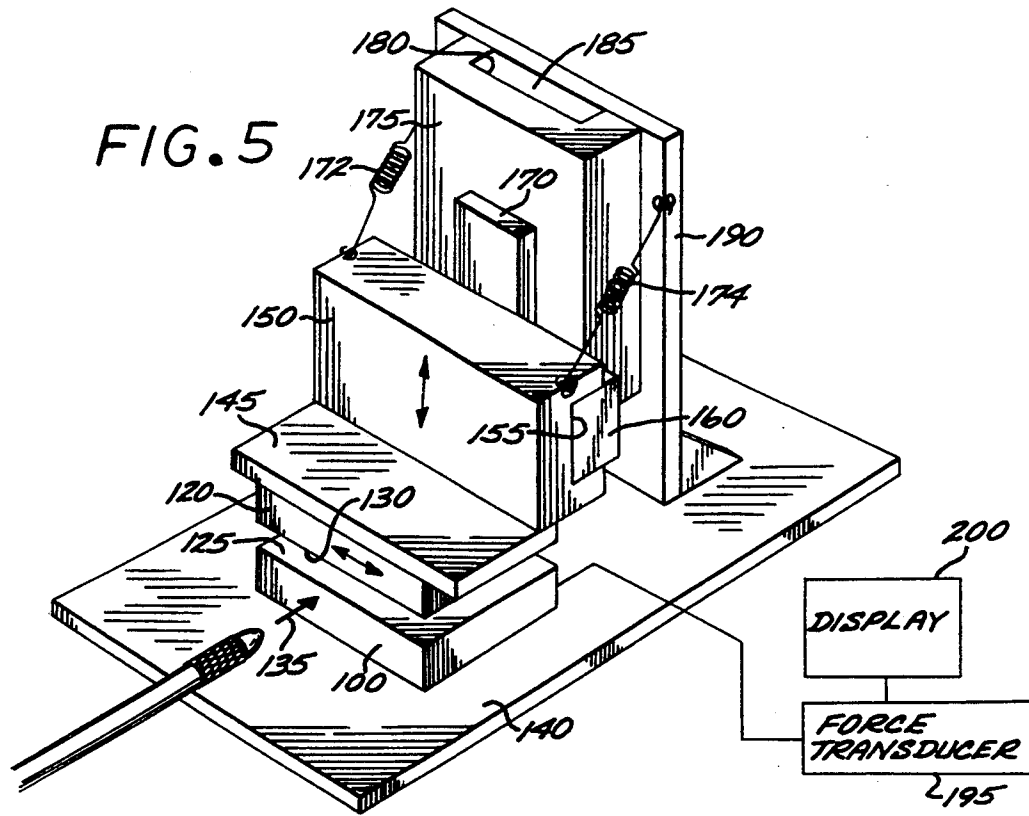

FIG. 8

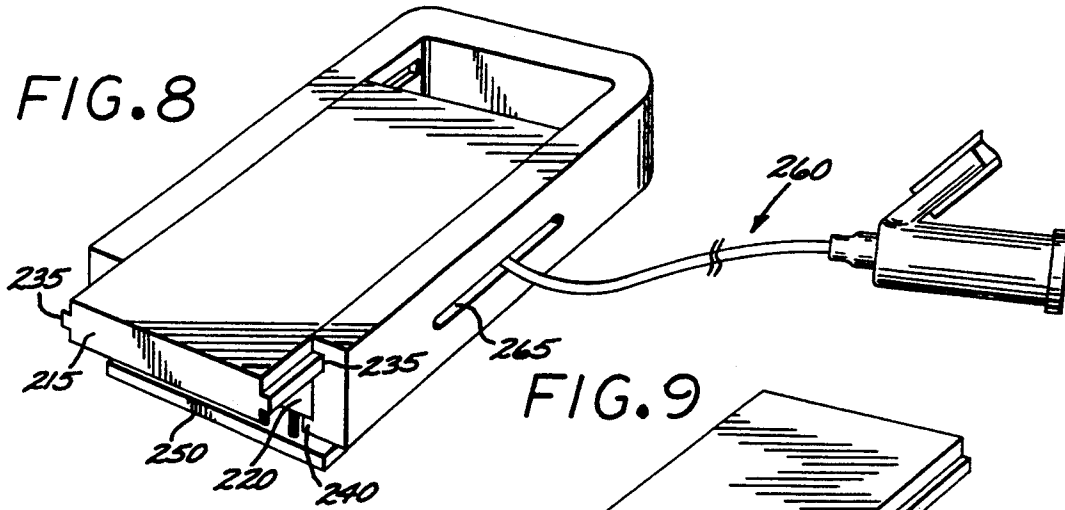

FIG. 9

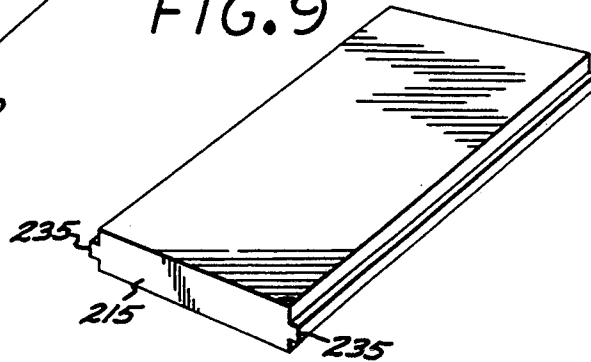

FIG. 10

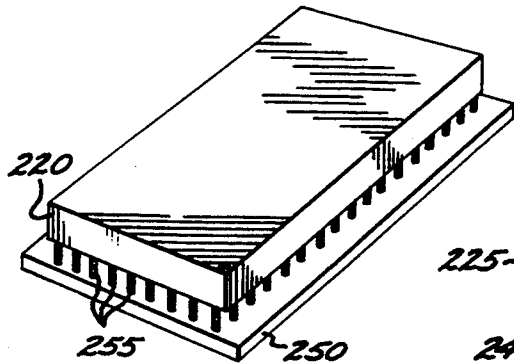
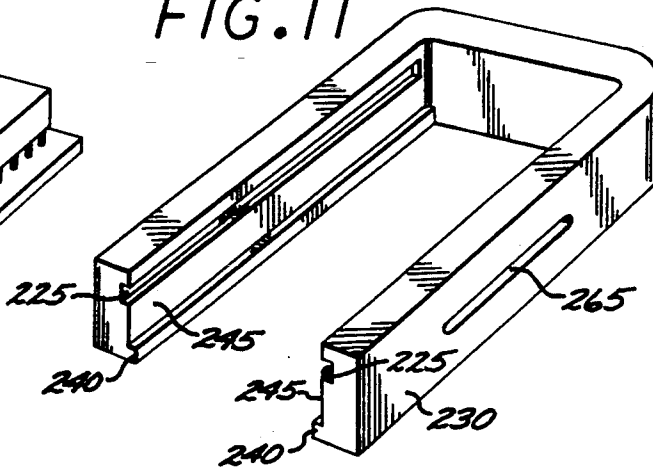

FIG. 11



STENT-LOADING MECHANISM

BACKGROUND OF THE INVENTION

Field of the Invention

This invention relates to a stent loading device that will automatically load a stent onto the distal end of a balloon dilatation catheter assembly, for example, of the kind used in typical percutaneous transluminal coronary angioplasty (PTCA) procedures.

In typical PTCA procedures, a guiding catheter is percutaneously introduced into the cardiovascular system of a patient through the brachial or femoral arteries and advanced through the vasculature until the distal of the guiding catheter end is in the ostium. A guidewire and a dilatation catheter having a balloon on the distal end are introduced through the guiding catheter with the guidewire sliding within the dilatation catheter. The guidewire is first advanced out of the guiding catheter into the patient's coronary vasculature and the dilatation catheter is advanced over the previously advanced guidewire until the dilatation balloon is properly positioned across the lesion. Once in position across the lesion, a flexible, expandable, preformed balloon is inflated to a predetermined size with a radiopaque liquid at relatively high pressures to radially compress the atherosclerotic plaque of the lesion against the inside of the artery wall and thereby dilate the lumen of the artery. The balloon is then deflated to a small profile, so that the dilatation catheter can be withdrawn from the patient's vasculature and blood flow resumed through the dilated artery. As should be appreciated by those skilled in the art, while the procedure just described is typical, it is not the only method used in angioplasty.

In angioplasty procedures of the kind referenced above, there may be restenosis of the artery, which may require another angioplasty procedure, a surgical bypass operation, or some method of repairing or strengthening the area. To reduce the chance of restenosis and strengthen the area, a physician can implant an intravascular prosthesis for maintaining vascular patency, typically called a stent, inside the artery at the lesion. The stent is typically expanded to a larger diameter, often by the balloon portion of the catheter. The stent may be of the self-expanding type.

SUMMARY OF THE INVENTION

This invention is directed to a vascular prosthesis loading device, which automatically loads a stent onto the distal end of a catheter assembly, with a minimum of human handling, to better secure the stent onto the catheter while the stent is being delivered through the patient's vasculature.

The present invention attempts to solve several problems associated with placing stents onto balloon catheters. In procedures where the stent is placed over the balloon portion of the catheter, one must crimp the stent onto the balloon portion, to prevent the stent from sliding off the catheter when the catheter is advanced in a patient's vasculature. In the past this crimping was often done by hand, which was found to be unsatisfactory due to uneven force being applied, resulting in non-uniform crimps. In addition, it is difficult to judge when a uniform and reliable crimp has been applied. Furthermore, the more the stent is handled, the greater the chance of human error in crimping the stent properly. Though some tools, such as ordinary pliers, have been used to apply the stent, these tools have not been

entirely adequate in achieving a satisfactory crimp. Further, some self-expanding stents are difficult to load by hand onto a delivery device such as a catheter.

In one embodiment of the present invention, the stent-loading device includes a tubular member housing a bladder. The tubular member and bladder are designed to hold a stent that is to be loaded onto a balloon catheter assembly. Upon placement of the stent over the balloon portion of the catheter, a valve in the loading device is activated to inflate the bladder. The bladder compresses the stent radially inwardly to a reduced diameter onto the balloon portion of the catheter, to achieve a snug fit. In this way the stent can be affixed onto the distal end of a balloon catheter with a minimum of human handling.

In other embodiments of the present invention, the stent-loading device is made of sliding plates having flat surfaces that allow a stent carrying catheter to be received in between them. The surfaces are moved relative to one another to apply force uniformly to the outside of the stent disposed on the catheter, allowing the stent to be crimped onto the outside of the catheter.

These and other advantages of the invention will become more apparent from the following detailed description thereof when taken in conjunction with the accompanying drawings.

BRIEF DESCRIPTION OF THE DRAWINGS

FIG. 1 is a cross-sectional schematic of one embodiment of the stent-loading device depicting the bladder and chamber for receiving the stent.

FIG. 2 is a cut-away perspective view of the stent loading device of FIG. 1.

FIG. 3 is a cut-away perspective view of the stent loading device of FIG. 1, showing a balloon catheter assembly about to be inserted into the device, and a stent received by the device.

FIG. 4 is a cut-away perspective view of the stent loading device of FIG. 1, when it is operated to load a stent onto a balloon catheter assembly that has been placed inside the device.

FIG. 5 is a perspective view of a second embodiment of the present invention depicting sliding plates with a stent mounted to be placed between the plates.

FIG. 6 is a perspective view of the back of one of the blocks of the embodiment shown in FIG. 5.

FIG. 7 is a side view of the second embodiment of the present invention.

FIG. 8 is a perspective view of a third embodiment of the present invention.

FIG. 9 shows the slider plate of the embodiment of FIG. 8.

FIG. 10 shows the spring-loaded plate of the embodiment of FIG. 8.

FIG. 11 shows the housing of the embodiment of FIG. 8.

DETAILED DESCRIPTION OF THE INVENTION

As shown by FIGS. 1-4, the first embodiment of the stent-loading device 1 includes an elongated tubular member 5, having an open end 10 and a sealed-off end 15. The tubular member houses an elastic bladder 20, which extends longitudinally along the inside of the tubular member. The bladder is secured to the tubular member by fastener ring 25, which clamps the bladder onto the tubular member. The bladder extends out of

Explore Litigation Insights

Docket Alarm provides insights to develop a more informed litigation strategy and the peace of mind of knowing you're on top of things.

Real-Time Litigation Alerts



Keep your litigation team up-to-date with **real-time alerts** and advanced team management tools built for the enterprise, all while greatly reducing PACER spend.

Our comprehensive service means we can handle Federal, State, and Administrative courts across the country.

Advanced Docket Research



With over 230 million records, Docket Alarm's cloud-native docket research platform finds what other services can't. Coverage includes Federal, State, plus PTAB, TTAB, ITC and NLRB decisions, all in one place.

Identify arguments that have been successful in the past with full text, pinpoint searching. Link to case law cited within any court document via Fastcase.

Analytics At Your Fingertips



Learn what happened the last time a particular judge, opposing counsel or company faced cases similar to yours.

Advanced out-of-the-box PTAB and TTAB analytics are always at your fingertips.

API

Docket Alarm offers a powerful API (application programming interface) to developers that want to integrate case filings into their apps.

LAW FIRMS

Build custom dashboards for your attorneys and clients with live data direct from the court.

Automate many repetitive legal tasks like conflict checks, document management, and marketing.

FINANCIAL INSTITUTIONS

Litigation and bankruptcy checks for companies and debtors.

E-DISCOVERY AND LEGAL VENDORS

Sync your system to PACER to automate legal marketing.