

Nov. 3, 1964

E. L. BAKER  
TUBE POINTER

3,154,978

Filed July 9, 1962

4 Sheets-Sheet 1

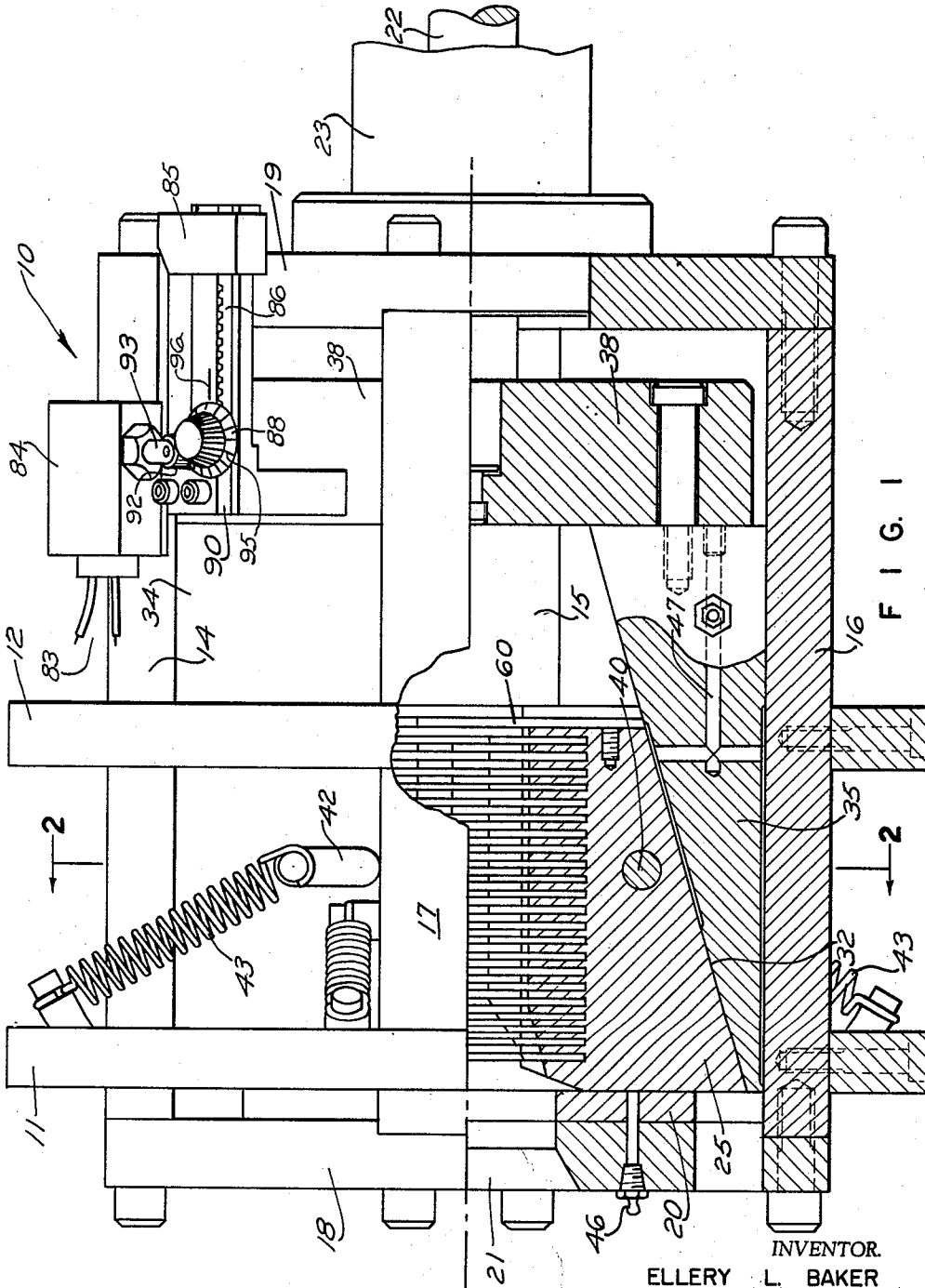

FIG. 1

INVENTOR.  
ELLERY L. BAKER  
BY

*Barlow & Barlow*  
ATTORNEYS

EDWARDS LIFESCIENCES EX 1223

Nov. 3, 1964

E. L. BAKER  
TUBE POINTER

3,154,978

Filed July 9, 1962

4 Sheets-Sheet 2

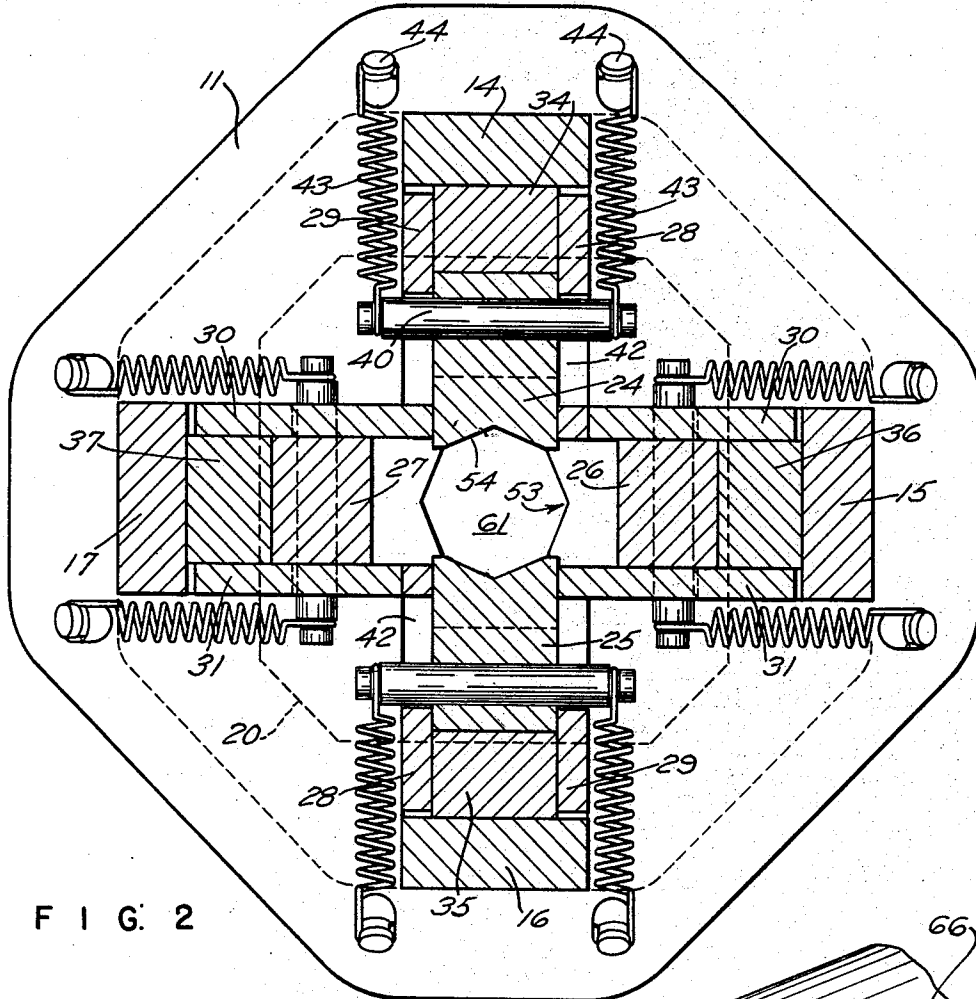

FIG. 2

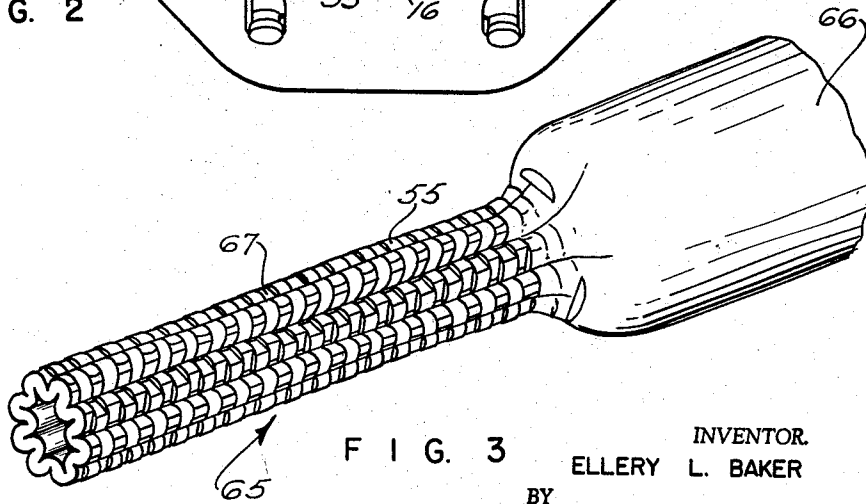

FIG. 3

INVENTOR  
ELLERY L. BAKER  
BY  
*Parlow & Parlow*  
ATTORNEYS

Nov. 3, 1964

E. L. BAKER  
TUBE POINTER

3,154,978

Filed July 9, 1962

4 Sheets-Sheet 3

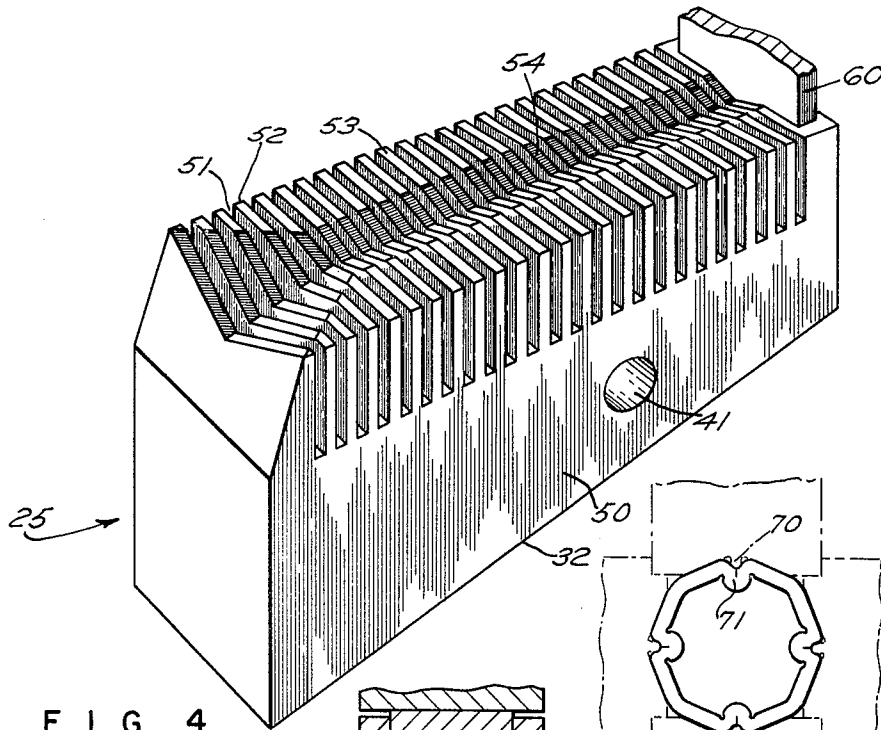

FIG. 4

FIG. 6

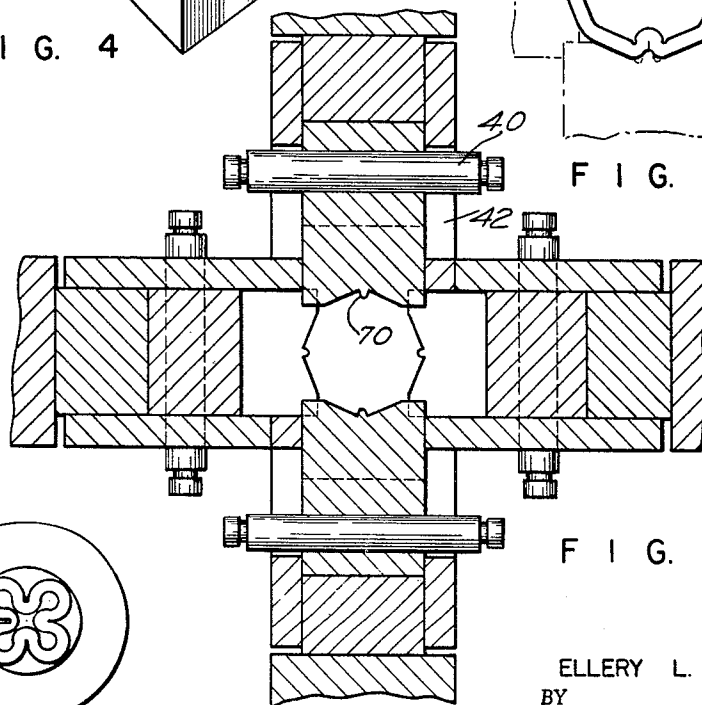

FIG. 5

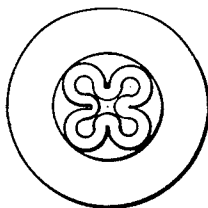

FIG. 7

INVENTOR.  
ELLERY L. BAKER  
BY  
*Barlow & Barlow*  
ATTORNEYS

Nov. 3, 1964

E. L. BAKER  
TUBE POINTER

3,154,978

Filed July 9, 1962

4 Sheets-Sheet 4

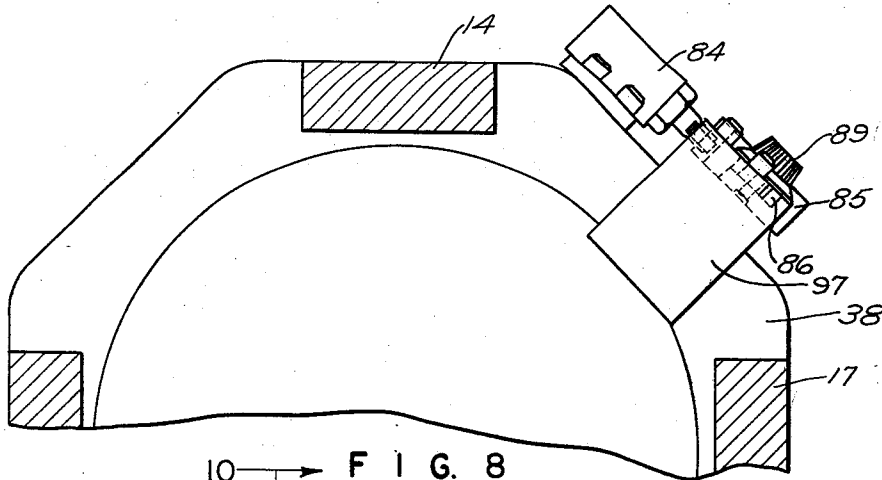

10 → FIG. 8

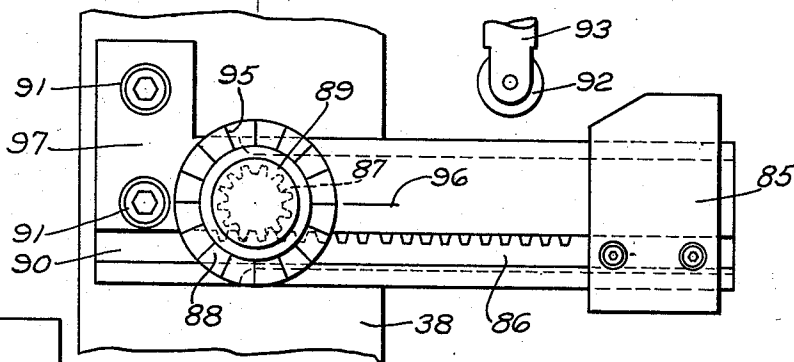

10 → FIG. 9

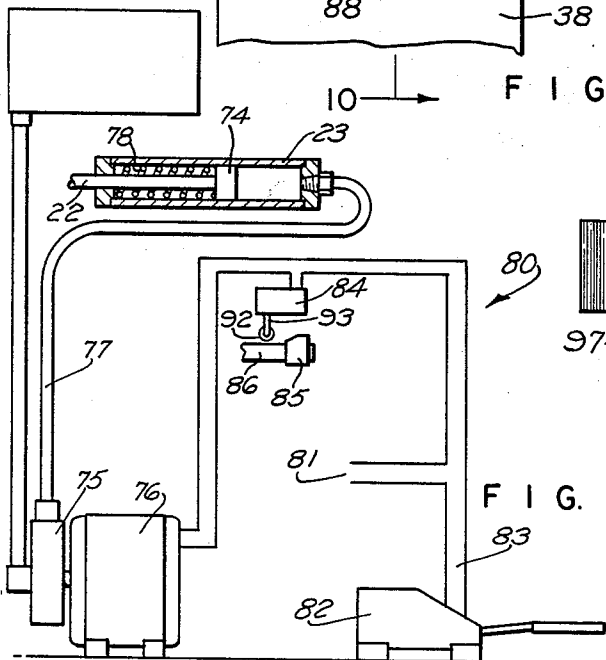

FIG. 10

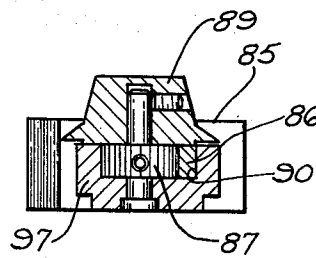

FIG. 11

INVENTOR  
ELLERY L. BAKER  
BY  
*Barlow & Barlow*  
ATTORNEYS

1

3,154,978

TUBE POINTER

Ellery L. Baker, Warwick, R.I., assignor to United Wire & Supply Corporation, a corporation of Rhode Island  
 Filed July 9, 1962, Ser. No. 208,502  
 8 Claims. (Cl. 78-15)

This application is a continuation-in-part of application, Serial No. 121,459, filed July 3, 1961, now abandoned.

This invention relates to a machine for compressing the end of a tube to form a so-called point thereon so that the tube may be easily inserted into a die for drawing the tube to reduce its diameter.

Rotary swaging has been used for some time to reduce the end of a tube to form a so-called point thereon, but this has more recently given away to the use of dies for folding in the stock of the tube and then compressing the remainder of the tube to form a point thereon. The usual folding of a tube is from diametrically opposite sides by means of projections on dies which move together, while other dies at 90° therefrom cooperate to move in the stock. The folded in portions usually contact and limit the reduction in size of the tube in the forming of a point. By these heretofore used methods a reduction of substantially 30 percent of the size of the tube was about the maximum. By reason of such a limit a large number of dies or pointing tools were needed for a full range of sizes. Approximately ten sets of dies were necessary for sizes of tubes varying from 1/4 inches to 1/16 of an inch.

A further difficulty was encountered in reducing the size of a tube by compression in that the tube would exude through the junction between the members which engage the tube for such compression.

One of the objects of this invention is to provide a pointing machine or device which will operate through a greater range of tube sizes than heretofore, such for instance as making one set of dies take the place of ten sets for the range of 1/4 to 1/16 which are heretofore used.

Another object of this invention is to provide a single set of dies which will perform a reduction on a tube of over 100 percent of its finished point diameter.

Another object of the invention is to adjustably select the amount of reduction of tube size to obtain the size of the point desired throughout a wide range.

Another object of the invention is to select the point size desired by a dial operation.

Another object of this invention is to provide a device which will prevent stock of the tube being reduced from exuding through the junction between the dies which engage and press the tube to smaller diameter.

Another object of the invention is to provide a surface on the reduced portion of the tube or its point which will afford a good gripping surface to be engaged by the tongs of a drawbench for pulling the tube through drawing dies.

Another object of the invention is to provide a point on the tube which will be stronger than points which have heretofore been formed on the end of the tube and thus prevent ripping or tearing of the stock of the work in the area of the point or where it has been reduced from the normal size of the tube.

Another object of the invention is to provide a device which will be much smaller than the old swaging machine which is utilized for tube pointing.

With these and other objects in view, the invention consists of certain novel features of construction as will be more fully described and particularly pointed out in the appended claims.

2

FIG. 1 is an elevation partly in section of the machine equipped with this invention;

FIG. 2 is a section on line 2-2 of FIG. 1;

FIG. 3 is a perspective view of a point formed on a tube in accordance with the machine here shown;

FIG. 4 is a perspective view of one of the jaws of the machine;

FIG. 5 is a sectional view of a modified form of machine and jaws;

FIG. 6 is an end view of the tube partially formed by the modified form of jaws of FIG. 5;

FIG. 7 is an end view of the tube point compressed until its opposite sides touch;

FIG. 8 is a fragmental section showing the location of the adjusting stop;

FIG. 9 is a plan of the stop adjusting device;

FIG. 10 is a section on line 10-10 of FIG. 9; and

FIG. 11 is a schematic view of the control mechanism.

In proceeding with this invention, I have provided a plurality of jaws or jaw members suitably guided in a housing or framework so as to move toward a common axis and a means for simultaneously moving these jaw members toward such a common axis to place pressure upon a tube which may be placed in their path of movement. Each of the jaws is provided with a plurality of fins or leaves, and the edges of adjacent jaws have these fins or leaves intermeshing or interlocking so that one supports the other and in this manner the jaw members encircle the axis toward which they move so that when they engage a work tube positioned in the opening between them and move into engagement with this tube, the tube cannot exude through the junction between the jaws as this interlocking prevents this. The shape of the engaging surface of the jaws may be varied, and generally the shaping will be such that as the tube to be operated on becomes smaller, the number of flat surfaces which are formed on the tube as compressed will be increased the smaller the tube becomes. In some instances I may provide a projection on these engaging surfaces so as to start the tube folding inwardly at certain locations. The general surface of the jaws may be such as to form a gradual taper on the tube so as not to strain or rip the stock of the tube by too an abrupt reduction. I also provide an adjustment which may be preset to limit the compression of the point to a certain amount that the desired size of point may be had.

With reference to the drawings, 10 designates generally the tube pointing machine which comprises a skeleton housing of two heavy plates 11 and 12, each of which has a cutout in the shape of a cross with bars 14, 15, 16 and 17 extending between them and located on the ends of the cross. These bars are provided with a head 18 at the forward end and a head 19 at the rear end. The head 18 has a smaller plate 20 between it and plate 11, and both have openings 21 at their centers through which the work may be positioned to be operated upon. An opening in the head 19 provides for the piston rod 22 to extend through from the hydraulic cylinder 23 for applying pressure to operate the jaw members.

In the present illustration of the device there are four jaw members arranged in diametrically opposite pairs, and as seen in FIGURE 2, one opposed pair comprises the jaws 24 and 25 while there is another opposed pair comprising jaws 26 and 27. Spaced members 28 and 29 engage the inner edges of the cutout cross and are welded to the plates 11 and 12 at these locations to provide guide ways for the jaw members 24 and 25 directing their path of sliding movement toward and from the axial center of the plates 11 and 12. Similarly, plates 30 and 31 are sup-

# Explore Litigation Insights

Docket Alarm provides insights to develop a more informed litigation strategy and the peace of mind of knowing you're on top of things.

## Real-Time Litigation Alerts



Keep your litigation team up-to-date with **real-time alerts** and advanced team management tools built for the enterprise, all while greatly reducing PACER spend.

Our comprehensive service means we can handle Federal, State, and Administrative courts across the country.

## Advanced Docket Research



With over 230 million records, Docket Alarm's cloud-native docket research platform finds what other services can't. Coverage includes Federal, State, plus PTAB, TTAB, ITC and NLRB decisions, all in one place.

Identify arguments that have been successful in the past with full text, pinpoint searching. Link to case law cited within any court document via Fastcase.

## Analytics At Your Fingertips



Learn what happened the last time a particular judge, opposing counsel or company faced cases similar to yours.

Advanced out-of-the-box PTAB and TTAB analytics are always at your fingertips.

## API

Docket Alarm offers a powerful API (application programming interface) to developers that want to integrate case filings into their apps.

## LAW FIRMS

Build custom dashboards for your attorneys and clients with live data direct from the court.

Automate many repetitive legal tasks like conflict checks, document management, and marketing.

## FINANCIAL INSTITUTIONS

Litigation and bankruptcy checks for companies and debtors.

## E-DISCOVERY AND LEGAL VENDORS

Sync your system to PACER to automate legal marketing.