

Jan. 5, 1954

L. W. ANDREWS
ADJUSTABLE DIE

2,664,996

Filed Feb. 23, 1951

4 Sheets-Sheet 1

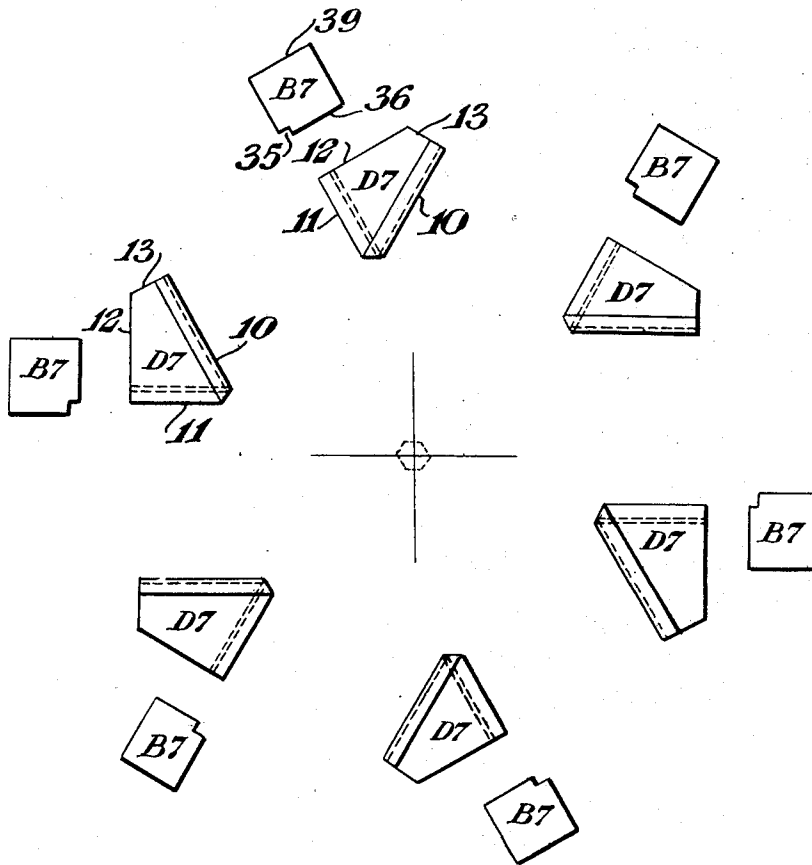

Fig. 1.

Inventor:
Leonard Wilfred Andrews;
By his attorneys,
Baldwin + Hight

EDWARDS LIFESCIENCES EX. 1210

Jan. 5, 1954

L. W. ANDREWS
ADJUSTABLE DIE

2,664,996

Filed Feb. 23, 1951

4 Sheets-Sheet 2

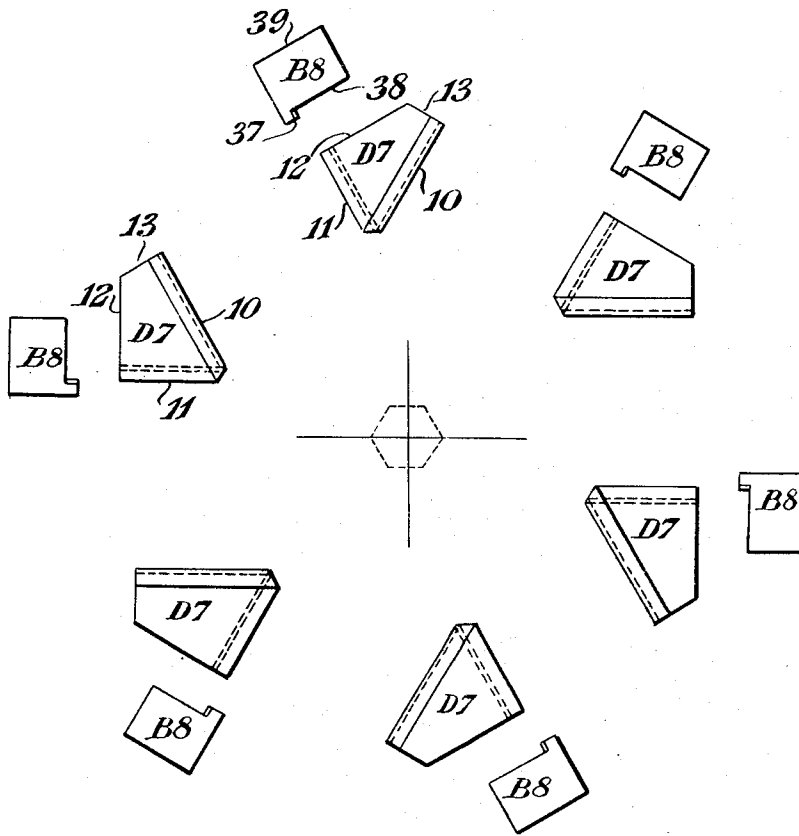

Fig. 2.

Inventor:
Leonard Wilfred Andrews;
By his attorneys,
Baldwin & Knight

Jan. 5, 1954

L. W. ANDREWS
ADJUSTABLE DIE

2,664,996

Filed Feb. 23, 1951

4 Sheets-Sheet 3

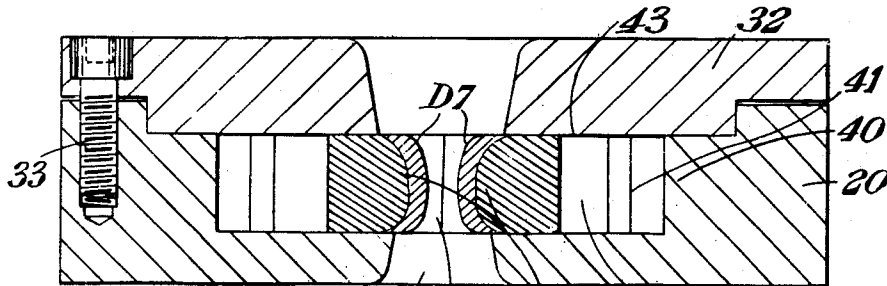

Fig. 4. 21 31 D7 B7

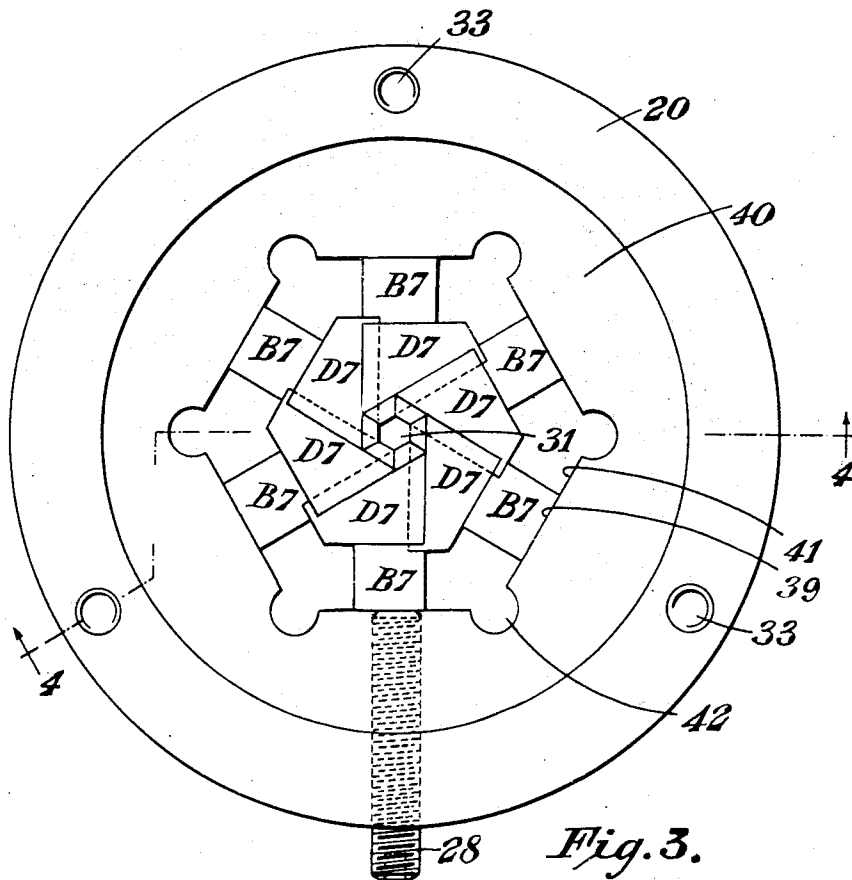

Fig. 3.

Inventor:
Leonard Wilfred Andrews,
by his attorneys,
Baldwin & Hight

Jan. 5, 1954

L. W. ANDREWS
ADJUSTABLE DIE

2,664,996

Filed Feb. 23, 1951

4 Sheets-Sheet 4

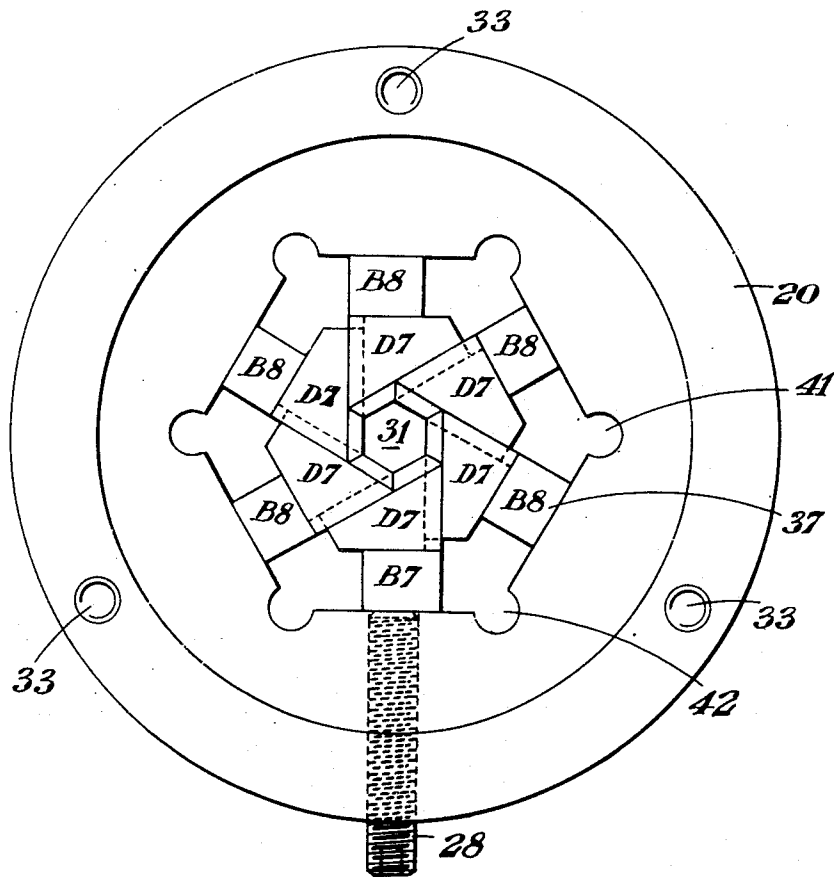

Fig. 5.

Inventor:
Leonard Wilfred Andrews
By his attorneys,
Baldwin & Wright

UNITED STATES PATENT OFFICE

2,664,996

ADJUSTABLE DIE

Leonard Wilfred Andrews, London, England, assignor to Murex Limited, Rainham, England, a company of Great Britain

Application February 23, 1951, Serial No. 212,369

Claims priority, application Great Britain
February 28, 1950

3 Claims. (Cl. 205—26)

1

This invention relates to an improved adjustable die suitable, for example, for drawing, forming or extruding bars of square, rectangular, hexagonal or other sections.

It is known that sets of accurately ground and shaped blocks faced with hard metal cemented tungsten carbide, when assembled and clamped together, can be used for the purpose of drawing bars of polygonal sections. Clamping screws, together with adjusting screws, are used to position the blocks in their proper assembly and, by adjustment, to determine the shape and size of the die-hole thus produced at the centre of the assembly. The nature of the components of the sets and the method of assembly and adjustment have been such, however, that setting to a predetermined size of hole is complicated and that the drawing range of any single complete assembly or die is limited. Furthermore, any single die assembly is relatively cumbersome and easily damaged by mis-handling or by bad setting, and, owing to the many screws employed, tends to lack rigidity.

An adjustable die according to the invention comprises (1) a set of die blocks shaped to nest together complementarily with slidable adjustment in assembly to form a die-hole having the same number of sides as the number of die blocks in the set, the said slidable adjustment enabling the assembly to be arranged to give various dimensions of the die hole; (2) a holder having an apertured base for supporting the die blocks and comprising an inner retaining wall; (3) a set of backing blocks snugly interposed between the said retaining wall and the die blocks, the backing blocks being formed to match a particular arrangement of the assembly of die blocks; and (4) means operable to compress the backing blocks between the said retaining wall and the assembled die blocks, and thus to clamp the latter firmly in position.

A cover plate, surmounting the whole assembly of die blocks and backing blocks and detachably secured to the holder, may act as a further clamping means for holding the assembly together.

Each die block may be formed of or faced with hard metal cemented tungsten carbide or other material suitable for the purpose of the die. The other parts are made, for example, of steel. The die block is preferably ground and lapped so that the die face, that is the face which constitutes a wall surface of the die-hole, has a convex cylindrical surface, whereby the die-hole is formed with a throat. A second face of each die-hole, which is inclined at the required angle to the die face.

2

convex die face of its adjacent die block. The outer surface, or third face, of each die block may be a plane surface, or two or more plane surfaces inclined to one another, according to the nature of the engagement thereon of the corresponding backing block which is interposed between the die block and the retaining wall of the holder. Different sets of die blocks may be provided for alternative use according to the form, as distinct from dimensions, of the die-hole section required.

It will be understood that one set of backing blocks corresponds to a particular setting of the assembly of a set of die blocks and therefore to a die-hole of predetermined dimensions produced with such assembly. Accordingly the adjustable die outfit will normally comprise a number of sets of backing blocks corresponding respectively to the different dimensions of die-holes required to be produced from one set of die blocks.

Advantages of the present invention are that a single set of die blocks may be used, with the appropriate sets of backing blocks, throughout substantially the full range of the adjustment of the assembly of die blocks to dimensions of die-hole; and that the assembly is relatively simple to handle, to adjust and to clamp to rigidity.

An embodiment of the invention is illustrated in the accompanying drawings of which:

Figure 1 is a plan view of a set of die blocks and a corresponding set of backing blocks, both sets of blocks being unassembled.

Figure 2 is a plan view showing a slight modification of the backing blocks of Figure 1, the die blocks being the same.

Figure 3 is a plan view of the blocks of Figure 1 assembled and mounted in a holder.

Figure 4 is a section on the line 4—4 of Figure 3 and including a cover plate.

Figure 5 is a plan view of the blocks of Figure 2 assembled and mounted in the same holder as that shown in Figure 3.

Figures 1 and 2 show identical sets of six die blocks, all marked D1, adapted for assembly to produce die-holes of hexagonal section. The backing blocks in Figure 1, all marked B1, are adapted to match an assembly of the die blocks when a relatively small die-hole of regular hexagonal section is formed. The backing blocks in Figure 2, all marked B2, are adapted to match an assembly of the die blocks when a relatively large die-hole of regular hexagonal section is formed. The essential difference between the blocks B1 and the blocks B2 is that the former have a front face with a recess which provides the face with two staggered parallel portions

Explore Litigation Insights

Docket Alarm provides insights to develop a more informed litigation strategy and the peace of mind of knowing you're on top of things.

Real-Time Litigation Alerts



Keep your litigation team up-to-date with **real-time alerts** and advanced team management tools built for the enterprise, all while greatly reducing PACER spend.

Our comprehensive service means we can handle Federal, State, and Administrative courts across the country.

Advanced Docket Research



With over 230 million records, Docket Alarm's cloud-native docket research platform finds what other services can't. Coverage includes Federal, State, plus PTAB, TTAB, ITC and NLRB decisions, all in one place.

Identify arguments that have been successful in the past with full text, pinpoint searching. Link to case law cited within any court document via Fastcase.

Analytics At Your Fingertips



Learn what happened the last time a particular judge, opposing counsel or company faced cases similar to yours.

Advanced out-of-the-box PTAB and TTAB analytics are always at your fingertips.

API

Docket Alarm offers a powerful API (application programming interface) to developers that want to integrate case filings into their apps.

LAW FIRMS

Build custom dashboards for your attorneys and clients with live data direct from the court.

Automate many repetitive legal tasks like conflict checks, document management, and marketing.

FINANCIAL INSTITUTIONS

Litigation and bankruptcy checks for companies and debtors.

E-DISCOVERY AND LEGAL VENDORS

Sync your system to PACER to automate legal marketing.