

(12) **United States Patent**  
**Haug et al.**

(10) **Patent No.:** **US 7,780,725 B2**  
(45) **Date of Patent:** **Aug. 24, 2010**

(54) **EVERTING HEART VALVE**

**FOREIGN PATENT DOCUMENTS**

(75) Inventors: **Ulrich R. Haug**, Campbell, CA (US);  
**Hans F. Valencia**, Berkeley, CA (US);  
**Robert A. Geshliger**, San Francisco, CA (US);  
**Tom Saul**, El Granada, CA (US);  
**Amr Salahieh**, Saratoga, CA (US);  
**Dwight P. Morejohn**, Davis, CA (US);  
**Kenneth J. Michlitsch**, Livermore, CA (US)

EP 0409929 B1 4/1997

(Continued)

**OTHER PUBLICATIONS**

Andersen, H.R. et al., "Transluminal implantation of artificial heart valves. Description of a new expandable aortic valve and initial results with implantation by catheter technique in closed chest pigs". Euro. Heart J. (1992) 13:704-708.

(Continued)

(73) Assignee: **Sadra Medical, Inc.**, Los Gatos, CA (US)

*Primary Examiner*—David Isabella  
*Assistant Examiner*—Ann Schillinger  
(74) *Attorney, Agent, or Firm*—Shay Glenn LLP

(\* ) Notice: Subject to any disclaimer, the term of this patent is extended or adjusted under 35 U.S.C. 154(b) by 1188 days.

(57) **ABSTRACT**

(21) Appl. No.: **10/870,340**

The present invention provides methods and apparatus for endovascularly replacing a patient's heart valve. The apparatus includes a replacement valve and an expandable anchor configured for endovascular delivery to a vicinity of the patient's heart valve. In some embodiments, the replacement valve is adapted to wrap about the anchor, for example, by everting during endovascular deployment. In some embodiments, the replacement valve is not connected to expandable portions of the anchor. In some embodiments, the anchor is configured for active foreshortening during endovascular deployment. In some embodiments, the anchor includes expandable lip and skirt regions for engaging the patient's heart valve during deployment. In some embodiments, the anchor comprises a braid fabricated from a single strand of wire. In some embodiments, the apparatus includes a lock configured to maintain anchor expansion. The invention also includes methods for endovascularly replacing a patient's heart valve. In some embodiments, the method includes the steps of endovascularly delivering a replacement valve and an expandable anchor to a vicinity of the heart valve, wrapping at least a portion of the replacement valve about the anchor, and expanding the anchor to a deployed configuration.

(22) Filed: **Jun. 16, 2004**

(65) **Prior Publication Data**

US 2005/0283231 A1 Dec. 22, 2005

(51) **Int. Cl.**  
**A61F 2/06** (2006.01)

(52) **U.S. Cl.** ..... **623/2.17**

(58) **Field of Classification Search** ..... 623/1.1-2.1,  
623/2.11-2.42; 128/898

See application file for complete search history.

(56) **References Cited**

**U.S. PATENT DOCUMENTS**

- 3,334,629 A 8/1967 Cohn
- 3,409,013 A 11/1968 Berry
- 3,540,431 A 11/1970 Mobin-Uddin
- 3,628,535 A 12/1971 Ostrowsky et al.

(Continued)

**31 Claims, 63 Drawing Sheets**

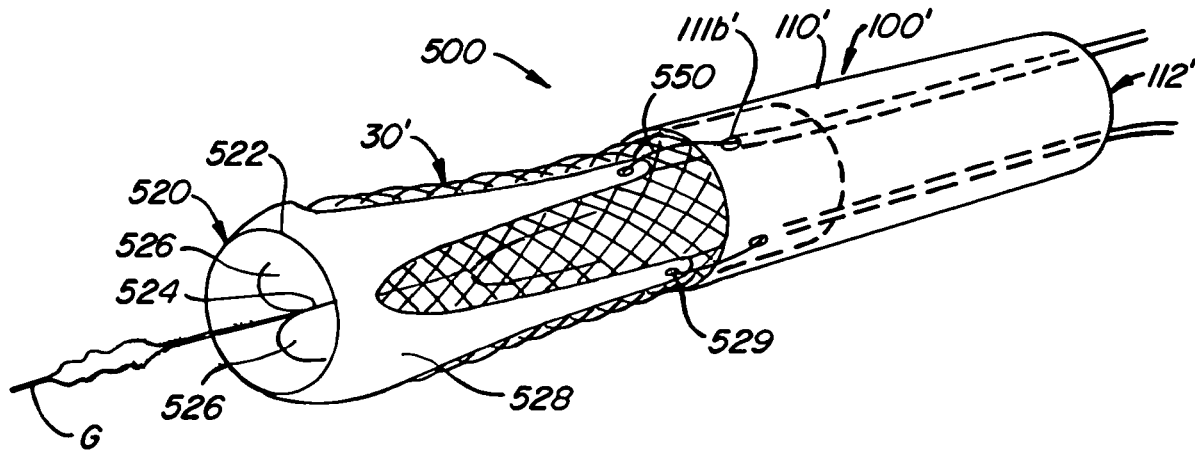

**Edwards Lifesciences v. Boston Scientific Scimed**  
IPD2017 01203 U.S. Patent 8,002,608

U.S. PATENT DOCUMENTS							
3,642,004	A	2/1972	Osthagen et al.	5,735,842	A	4/1998	Krueger et al.
3,657,744	A	4/1972	Ersek	5,769,812	A	6/1998	Stevens et al.
3,671,979	A	6/1972	Mouloupoulos	5,800,456	A	9/1998	Maeda et al.
3,795,246	A	3/1974	Sturgeon	5,807,405	A	9/1998	Vanney et al.
3,839,741	A	10/1974	Haller	5,817,126	A	10/1998	Imran
3,868,956	A	3/1975	Alfidi et al.	5,824,041	A	10/1998	Lenker et al.
3,874,388	A	4/1975	King et al.	5,824,043	A	10/1998	Cottone, Jr.
4,056,854	A	11/1977	Boretos et al.	5,824,053	A	10/1998	Khosravi et al.
4,106,129	A	8/1978	Carpentier et al.	5,824,055	A	10/1998	Spiridigliozzi et al.
4,233,690	A	11/1980	Akins	5,824,056	A	10/1998	Rosenberg
4,291,420	A	9/1981	Reul	5,824,064	A	10/1998	Taheri
4,326,306	A	4/1982	Poler	5,840,081	A	11/1998	Andersen et al.
4,423,809	A	1/1984	Mazzocco	5,843,158	A	12/1998	Lenker et al.
4,425,908	A	1/1984	Simon	5,855,597	A	1/1999	Jayaraman
4,501,030	A	2/1985	Lane	5,855,601	A	1/1999	Bessler et al.
4,580,568	A	4/1986	Gianturco	5,860,966	A	1/1999	Tower
4,602,911	A	7/1986	Ahmadi et al.	5,861,024	A	1/1999	Rashidi
4,610,688	A	9/1986	Silvestrini et al.	5,861,028	A	1/1999	Angell
4,647,283	A	3/1987	Carpentier et al.	5,868,783	A	2/1999	Tower
4,648,881	A	3/1987	Carpentier et al.	5,876,448	A	3/1999	Thompson et al.
4,655,218	A	4/1987	Kulik et al.	5,885,228	A	3/1999	Rosenman et al.
4,655,771	A	4/1987	Wallsten	5,888,201	A	3/1999	Stinson et al.
4,662,885	A	5/1987	DiPisa, Jr.	5,891,191	A	4/1999	Stinson
4,665,906	A	5/1987	Jervis	5,895,399	A	4/1999	Barbut et al.
4,710,192	A	12/1987	Liotta et al.	5,907,893	A	6/1999	Zadno-Azizi et al.
4,733,665	A	3/1988	Palmaz	5,910,154	A	6/1999	Tsugita et al.
4,755,181	A	7/1988	Igoe	5,911,734	A	6/1999	Tsugita et al.
4,796,629	A	1/1989	Grayzel	5,925,063	A	7/1999	Khosravi
4,819,751	A	4/1989	Shimada et al.	5,944,738	A	8/1999	Amplatz et al.
4,834,755	A	5/1989	Silvestrini et al.	5,954,766	A	9/1999	Zadno-Azizi et al.
4,856,516	A	8/1989	Hillstead	5,957,949	A	9/1999	Leonhardt et al.
4,865,600	A	9/1989	Carpentier et al.	5,968,070	A	10/1999	Bley et al.
4,872,874	A	10/1989	Taheri	5,984,957	A	11/1999	Laptewicz, Jr. et al.
4,909,252	A	3/1990	Goldberger	5,984,959	A	11/1999	Robertson et al.
4,917,102	A	4/1990	Miller et al.	5,993,469	A	11/1999	McKenzie et al.
4,954,126	A	9/1990	Wallsten	5,997,557	A	12/1999	Barbut et al.
4,986,830	A	1/1991	Owens et al.	6,010,522	A	1/2000	Barbut et al.
4,994,077	A	2/1991	Dobben	6,022,370	A	2/2000	Tower
5,002,559	A	3/1991	Tower	6,027,520	A	2/2000	Tsugita et al.
5,064,435	A	11/1991	Porter	6,027,525	A	2/2000	Suh et al.
5,161,547	A	11/1992	Tower	6,042,598	A	3/2000	Tsugita et al.
5,163,953	A	11/1992	Vince	6,042,607	A	3/2000	Williamson, IV et al.
5,209,741	A	5/1993	Spaeth	6,051,014	A	4/2000	Jang
5,217,483	A	6/1993	Tower	6,123,723	A	9/2000	Konya et al.
5,258,042	A	11/1993	Mehta	6,142,987	A	11/2000	Tsugita
5,332,402	A	7/1994	Teitelbaum et al.	6,146,366	A	11/2000	Schachar
5,350,398	A	9/1994	Pavcnik et al.	6,162,245	A	12/2000	Jayaraman
5,370,685	A	12/1994	Stevens	6,165,200	A	12/2000	Tsugita et al.
5,389,106	A	2/1995	Tower	6,168,579	B1	1/2001	Tsugita
5,397,351	A	3/1995	Pavcnik et al.	6,168,614	B1	1/2001	Andersen et al.
5,411,552	A	5/1995	Andersen et al.	6,171,327	B1	1/2001	Daniel et al.
5,425,762	A	6/1995	Muller	6,179,859	B1	1/2001	Bates
5,431,676	A	7/1995	Dubrul et al.	6,197,053	B1	3/2001	Cosgrove et al.
5,443,495	A	8/1995	Buscemi et al.	6,200,336	B1	3/2001	Pavcnik et al.
5,443,499	A	8/1995	Schmitt	6,221,006	B1	4/2001	Dubrul et al.
5,476,506	A	12/1995	Lunn	6,221,091	B1	4/2001	Khosravi
5,476,510	A	12/1995	Eberhardt et al.	6,221,096	B1	4/2001	Aiba et al.
5,507,767	A	4/1996	Maeda et al.	6,231,544	B1	5/2001	Tsugita et al.
5,545,133	A	8/1996	Burns et al.	6,231,551	B1	5/2001	Barbut
5,545,211	A	8/1996	An et al.	6,241,757	B1	6/2001	An et al.
5,549,665	A	8/1996	Vesely et al.	6,245,102	B1	6/2001	Jayaraman
5,554,185	A	9/1996	Block et al.	6,258,114	B1	7/2001	Konya et al.
5,575,818	A	11/1996	Pinchuk	6,258,115	B1	7/2001	Dubrul
5,645,559	A	7/1997	Hachtman et al.	6,258,120	B1	7/2001	McKenzie et al.
5,662,671	A	9/1997	Barbut et al.	6,270,513	B1	8/2001	Tsugita et al.
5,667,523	A	9/1997	Bynon et al.	6,277,555	B1	8/2001	Duran et al.
5,674,277	A	10/1997	Freitag	6,309,417	B1	10/2001	Spence et al.
5,695,498	A	12/1997	Tower	6,319,281	B1	11/2001	Patel
5,713,953	A	2/1998	Vallana et al.	6,327,772	B1	12/2001	Zadno-Azizi et al.
				6,336,934	B1	1/2002	Gilson et al.
				6,336,937	B1	1/2002	Vonesh et al.

US 7,780,725 B2

6,352,708	B1	3/2002	Duran et al.	6,953,332	B1	10/2005	Kurk et al.
6,361,545	B1	3/2002	Macoviak et al.	6,964,673	B2	11/2005	Tsugita et al.
6,371,970	B1	4/2002	Khosravi et al.	6,969,395	B2	11/2005	Eskurl et al.
6,371,983	B1	4/2002	Lane	6,974,464	B2	12/2005	Quijano et al.
6,379,383	B1	4/2002	Palmaz et al.	6,974,474	B2	12/2005	Pavcnik et al.
6,398,807	B1	6/2002	Chouinard et al.	6,974,476	B2	12/2005	McGuckin, Jr. et al.
6,409,750	B1	6/2002	Hyodoh et al.	6,979,350	B2	12/2005	Moll et al.
6,416,510	B1	7/2002	Altman et al.	6,984,242	B2	1/2006	Campbell et al.
6,425,916	B1	7/2002	Garrison et al.	7,011,681	B2	3/2006	Veseley
6,440,164	B1	8/2002	DiMatteo et al.	7,018,406	B2	3/2006	Seguin et al.
6,454,799	B1	9/2002	Schreck	7,025,791	B2	4/2006	Levine et al.
6,458,153	B1	10/2002	Bailey et al.	7,037,331	B2	5/2006	Mitelberg et al.
6,468,303	B1	10/2002	Amplatz et al.	7,166,097	B2	1/2007	Barbut
6,475,239	B1	11/2002	Campbell et al.	7,175,653	B2	2/2007	Gaber
6,482,228	B1*	11/2002	Norred ..... 623/2.17	7,175,654	B2	2/2007	Bonsignore et al.
6,494,909	B2	12/2002	Greenhalgh	7,189,258	B2	3/2007	Johnson et al.
6,503,272	B2	1/2003	Duerig et al.	7,191,018	B2	3/2007	Gielen et al.
6,508,833	B2	1/2003	Pavcnik et al.	7,235,093	B2	6/2007	Gregorich
6,527,800	B1	3/2003	McGuckin, Jr. et al.	7,258,696	B2	8/2007	Rabkin et al.
6,530,949	B2	3/2003	Konya et al.	7,374,560	B2	5/2008	Ressemann et al.
6,537,297	B2	3/2003	Tsuigita et al.	2001/0021872	A1*	9/2001	Bailey et al. .... 623/1.24
6,540,768	B1	4/2003	Diaz et al.	2001/0025196	A1	9/2001	Chinn et al.
6,562,058	B2	5/2003	Seguin et al.	2001/0032013	A1	10/2001	Marton
6,592,546	B1	7/2003	Barbut et al.	2001/0039450	A1	11/2001	Pavcnik et al.
6,592,614	B2	7/2003	Lenker et al.	2001/0041928	A1	11/2001	Pavcnik et al.
6,610,077	B1	8/2003	Hancock et al.	2001/0041930	A1	11/2001	Globerman et al.
6,616,682	B2	9/2003	Joergensen et al.	2001/0044634	A1	11/2001	Michael et al.
6,622,604	B1	9/2003	Chouinard et al.	2001/0044656	A1	11/2001	Williamson et al.
6,623,518	B2	9/2003	Thompson et al.	2002/0002396	A1	1/2002	Fulkerson
6,632,243	B1	10/2003	Zadno-Azizi et al.	2002/0010489	A1	1/2002	Grayzel et al.
6,635,068	B1	10/2003	Dubrul et al.	2002/0029981	A1	3/2002	Nigam
6,635,079	B2	10/2003	Unsworth et al.	2002/0032480	A1	3/2002	Spence et al.
6,652,571	B1	11/2003	White et al.	2002/0032481	A1	3/2002	Gabbay
6,652,578	B2	11/2003	Bailey et al.	2002/0052651	A1	5/2002	Myers et al.
6,663,588	B2	12/2003	DuBois et al.	2002/0055769	A1	5/2002	Wang
6,663,663	B2	12/2003	Kim et al.	2002/0058995	A1	5/2002	Stevens
6,669,724	B2	12/2003	Park et al.	2002/0077696	A1	6/2002	Zadno-Azizi et al.
6,673,089	B1	1/2004	Yassour et al.	2002/0082609	A1	6/2002	Green
6,673,109	B2	1/2004	Cox	2002/0095173	A1	7/2002	Mazzocchi et al.
6,676,698	B2	1/2004	McGuckin, Jr. et al.	2002/0095209	A1	7/2002	Zadno-Azizi et al.
6,682,543	B2	1/2004	Barbut et al.	2002/0111674	A1	8/2002	Chouinard et al.
6,682,558	B2	1/2004	Tu et al.	2002/0120328	A1	8/2002	Pathak et al.
6,682,559	B2	1/2004	Myers et al.	2002/0151970	A1	10/2002	Garrison et al.
6,685,739	B2	2/2004	DiMatteo et al.	2002/0161392	A1	10/2002	Dubrul
6,689,144	B2	2/2004	Gerberding	2002/0161394	A1	10/2002	Macoviak et al.
6,689,164	B1	2/2004	Seguin	2002/0177766	A1	11/2002	Mogul
6,692,512	B2	2/2004	Jang	2002/0188341	A1	12/2002	Elliott
6,695,864	B2	2/2004	Macoviak et al.	2002/0188344	A1	12/2002	Bolea et al.
6,695,865	B2	2/2004	Boyle et al.	2002/0193871	A1	12/2002	Beyersdorf et al.
6,702,851	B1	3/2004	Chinn et al.	2003/0014104	A1	1/2003	Cribier
6,712,842	B1*	3/2004	Gifford et al. .... 623/1.13	2003/0023303	A1	1/2003	Palmaz et al.
6,712,843	B2	3/2004	Elliott	2003/0028247	A1	2/2003	Cali
6,714,842	B1*	3/2004	Ito ..... 700/302	2003/0036791	A1	2/2003	Philipp et al.
6,719,789	B2	4/2004	Cox	2003/0040771	A1	2/2003	Hyodoh et al.
6,730,118	B2	5/2004	Spenser et al.	2003/0040772	A1	2/2003	Hyodoh et al.
6,730,377	B2	5/2004	Wang	2003/0050694	A1	3/2003	Yang et al.
6,733,525	B2	5/2004	Yang et al.	2003/0055495	A1	3/2003	Pease et al.
6,736,846	B2	5/2004	Cox	2003/0060844	A1	3/2003	Borillo et al.
6,752,828	B2	6/2004	Thornton	2003/0070944	A1	4/2003	Nigam
6,758,855	B2	7/2004	Fulton, III et al.	2003/0109924	A1	6/2003	Cribier
6,767,345	B2	7/2004	St. Germain et al.	2003/0109930	A1	6/2003	Bluni et al.
6,773,454	B2	8/2004	Wholey et al.	2003/0125795	A1	7/2003	Pavcnik et al.
6,776,791	B1	8/2004	Stallings et al.	2003/0130729	A1	7/2003	Paniagua et al.
6,790,229	B1	9/2004	Berrekouw	2003/0144732	A1	7/2003	Cosgrove et al.
6,790,237	B2	9/2004	Stinson	2003/0149475	A1	8/2003	Hyodoh et al.
6,821,297	B2	11/2004	Snyders	2003/0149476	A1	8/2003	Damm et al.
6,863,668	B2	3/2005	Gillespie et al.	2003/0149478	A1	8/2003	Figulla et al.
6,887,266	B2	5/2005	Williams et al.	2003/0153974	A1	8/2003	Spenser et al.
6,890,340	B2	5/2005	Duane	2003/0176884	A1	9/2003	Berrada et al.
6,893,459	B1	5/2005	Macoviak	2003/0181850	A1	9/2003	Diamond et al.
6,905,743	B1	6/2005	Chen et al.	2003/0187495	A1	10/2003	Cully et al.



- Bodnar, E. et al., *Replacement Cardiac Valves*, Pergamon Publishing Corporation, New York, (1991), 307-322.
- Boudjemline, Y. et al., "Percutaneous implantation of a valve in the descending aorta in lambs". *Euro. Heart J.* (2002) 23:13, 1045-1049.
- Boudjemline, Y. et al., "Percutaneous Pulmonary Valve Replacement in a Large Right Ventricular Outflow Tract". *J. of Am. College of Cardio.* (2004) 43:6, 1082-1087.
- Boudjemline, Y. et al., "Percutaneous valve insertion: A new approach?" *J. of Thoracic and Cardio. Surg.* (2003) 125:3, 741-743.
- Boudjemline, Y. et al., "Steps Toward Percutaneous Aortic Valve Replacement." *Circulation* (2002) 775-778.
- Cribier, A. et al., "Early Experience with Percutaneous Transcatheter Implantation of Heart Valve Prosthesis for the Treatment of End-Stage Inoperable Patients with Calcific Aortic Stenosis". *J. or Am. Coll. of Cardio.* (2004) 43:4, 698-703.
- Cribier, A., et al., "Percutaneous Transcatheter Implantation of an Aortic Valve Prosthesis for Calcific Aortic Stenosis: First Human Case Description." *Circulation* (2002) 3006-3008.
- Cribier, A., et al., "Percutaneous Transcatheter Implantation of an Aortic Valve Prosthesis for Calcific Aortic Stenosis: First Human Case". *Percutaneous Valve Technologies, Inc.* (2002).
- Ferrari, M. et al., "Percutaneous transvascular aortic valve replacement with self expanding stent-valve device". Poster from the presentation given at SMIT 2000, 12<sup>th</sup> International Conference (Sep. 5, 2000).
- Hijazi, Z.M., "Transcatheter Valve Replacement: A New Era of Percutaneous Cardiac Intervention Begins". *J. of Am. College of Cardio.* (2004) 43:6, 1088-1089.
- Huber, C.H. et al., "Do valved stents compromise coronary flow?" *European Journal of Cardio-thoracic Surgery*, (2004) 25:754-759.
- Knudsen, L. L. et al., "Catheter-implanted prosthetic heart valves". *Int'l J. of Art. Organs*, (1993) 16:5, 253-263.
- Kort, S. et al., "Minimally invasive aortic valve replacement: Echocardiographic and clinical results". *Am. Heart J.* (2001) 142:3, 476-481.
- Love, C. et al., *The Autogenous Tissue Heart Valve: Current Status*, *Journal of Cardiac Surgery*, (1991) 6:4, 499-507.
- Lutter, G. et al., "Percutaneous aortic valve replacement: An experimental study. I. Studies on implantation." *J. of Thoracic and Cardio. Surg.* (2002) 123:4, 768-776.
- Mouloupoulos, S. D. et al., "Catheter-Mounted Aortic Valves," *Annals of Thoracic Surg.* (1971) 11:5, 423-430.
- Paniagua, D. et al., "Percutaneous heart valve in the chronic in vitro testing model". *Circulation* (2002), 106:e51-e52, American heart Association, Inc.
- Paniagua, D. et al., *Heart Watch* (2004), Spring, 2004 Edition, Texas Heart Institute.
- Pavcnik, D. et al., "Percutaneous bioprosthetic venous valve: A long-term study in sheep". *J. of Vascular Surg.* (2002) 35:3, 598-603.
- Phillips, S. J. et al., "A Temporary Catheter-Tip Aortic Valve: Hemodynamic Effects on Experimental Acute Aortic Insufficiency". *Annals of Thoracic Surg.* (1976) 21:2, 134-136.
- Sochman, J. et al., "Percutaneous Transcatheter Aortic Disc Valve Prosthesis Implantation: A Feasibility Study". *Cardiovasc. Intervent. Radiol.* (2000) 23, 384-388.
- Stuart, M., "In Heart Valves, A Brave, New Non-Surgical World". *Start-Up* (2004) 9-17.
- Vahanian, A. et al., "Percutaneous Approaches to Valvular Disease". *Circulation* (2004) 109, 1572-1579.
- Van Herwerden, L. A. et al., "Percutaneous valve implantation: back to the future?" *Euro. Heart J.* (2002) 23:18, 1415-1416.
- Zhou, J. Q. et al., "Self-expandable valved stent of large size: off-bypass implantation in pulmonary position". *Eur. J. Cardiothorac.* (2003) 24, 212-216.
- Salahieh, A. et al. U.S. Appl. No. 10/746,280 entitled "Repositionable heart valve and method", filed Dec. 23, 2003.
- Salahieh, A. et al. U.S. Appl. No. 10/893,131 entitled "Methods and apparatus for endovascularly replacing a patient's heart valve", filed Jul. 15, 2004.
- Salahieh, A. et al. U.S. Appl. No. 10/893,151, entitled "Methods and apparatus for endovascularly replacing a patient's heart valve", filed Jul. 15, 2004.
- Salahieh, A. et al. U.S. Appl. No. 10/893,142, entitled "Methods and apparatus for endovascularly replacing a patient's heart valve", filed Jul. 15, 2004.
- Salahieh, A. et al. U.S. Appl. No. 10/920,736, entitled "Apparatus and methods for protecting against embolization during endovascular heart replacement", filed Aug. 17, 2004.
- Salahieh, A. et al., U.S. Appl. No. 10/746,240, entitled "Heart valve anchor and method", filed Dec. 23, 2003.
- Salahieh, A. et al., U.S. Appl. No. 10/972,287, entitled "Leaflet engagement elements and methods for use thereof", filed Oct. 21, 2004.
- Salahieh, A. et al., U.S. Appl. No. 10/971,535, entitled "Leaflet engagement elements and methods for use thereof", filed Oct. 21, 2004.
- Salahieh, A. et al., U.S. Appl. No. 10/746,120, entitled "Externally expandable heart valve anchor and method", filed Dec. 23, 2003.
- Salahieh, A. et al., U.S. Appl. No. 10/982,388, entitled "Methods and apparatus for endovascularly replacing a heart valve", filed Nov. 5, 2004.
- Salahieh, A. et al., U.S. Appl. No. 10/746,285, entitled "Retrievable heart valve anchor and method", filed Dec. 23, 2003.
- Salahieh, A. et al., U.S. Appl. No. 10/982,692, entitled "Retrievable heart valve anchor and method", filed Nov. 5, 2004.
- Salahieh, A. et al., U.S. Appl. No. 10/746,887, entitled "Low profile heart valve and delivery system", filed Dec. 23, 2003.
- Salahieh, A. et al., U.S. Appl. No. 10/746,872, entitled "Locking heart valve anchor", filed Dec. 23, 2003.
- Salahieh, A. et al., U.S. Appl. No. 10/911,059, entitled "Replacement valve and anchor", filed Aug. 3, 2004.
- Salahieh, A. et al., U.S. Appl. No. 10/746,942, entitled "Two-piece heart valve and anchor", filed Dec. 23, 2003.
- Boudjemline, Y. et al. *Percutaneous implantation of a biological valve in the aorta to treat aortic valve insufficiency—a sheep study. Med Sci Monit.* (2002) vol. 8, No. 4, pp. BR113-BR116.
- Fawzi, et al., U.S. Appl. No. 11/155,309, entitled "Apparatus and methods for intravascular embolic protection," filed Jun. 16, 2005.
- Salahieh, et al., U.S. Appl. No. 11/232,441, entitled "Methods and apparatus for endovascular heart valve replacement comprising tissue grasping elements," filed Sep. 20, 2005.
- Salahieh, et al., U.S. Appl. No. 11/232,444, entitled "Methods and apparatus for endovascular heart valve replacement comprising tissue grasping elements," filed Sep. 20, 2005.
- Salahieh, et al., U.S. Appl. No. 11/274,889, entitled "Medical implant deployment tool," filed Nov. 14, 2005.
- Salahieh, et al., U.S. Appl. No. 11/314,183, entitled "Medical Device Delivery," filed Dec. 20, 2005.
- Salahieh, et al., U.S. Appl. No. 11/314,969, entitled "Methods And Apparatus For Performing Valvuloplasty," filed Dec. 20, 2005.
- Salahieh, et al., U.S. Appl. No. 11/275,912, entitled "Medical Implant Delivery and Deployment Tool," filed Feb. 2, 2006.
- Salahieh, et al., U.S. Appl. No. 11/275,913, entitled "Two-Part Package for Medical Implant," filed Feb. 2, 2006.
- Salahieh, et al., U.S. Appl. No. 11/531,980, "Externally expandable heart valve anchor and method," filed Sep. 14, 2006.
- Salahieh, et al., U.S. Appl. No. 11/532,019, "Methods and apparatus for endovascularly replacing heart valve," filed Sep. 14, 2006.
- Haug, et al; U.S. Appl. No. 11/716,123, entitled "Methods and apparatus for endovascularly replacing a heart valve," filed Mar. 9, 2007.
- Salahieh, et al; U.S. Appl. No. 11/706,549, entitled "Systems and Methods for Delivering a Medical Implant," filed Feb. 14, 2007.
- Salahieh, et al; U.S. Appl. No. 11/732,906 entitled "Assessing the location and performance of replacement heart valves," filed Apr. 4, 2007.
- Haug et al.; U.S. Appl. No. 12/492,512 entitled "Everting Heart Valve," filed Jun. 26, 2009.
- Paul et al.; U.S. Appl. No. 12/578,463 entitled "Medical Devices and

# Explore Litigation Insights

Docket Alarm provides insights to develop a more informed litigation strategy and the peace of mind of knowing you're on top of things.

## Real-Time Litigation Alerts



Keep your litigation team up-to-date with **real-time alerts** and advanced team management tools built for the enterprise, all while greatly reducing PACER spend.

Our comprehensive service means we can handle Federal, State, and Administrative courts across the country.

## Advanced Docket Research



With over 230 million records, Docket Alarm's cloud-native docket research platform finds what other services can't. Coverage includes Federal, State, plus PTAB, TTAB, ITC and NLRB decisions, all in one place.

Identify arguments that have been successful in the past with full text, pinpoint searching. Link to case law cited within any court document via Fastcase.

## Analytics At Your Fingertips



Learn what happened the last time a particular judge, opposing counsel or company faced cases similar to yours.

Advanced out-of-the-box PTAB and TTAB analytics are always at your fingertips.

## API

Docket Alarm offers a powerful API (application programming interface) to developers that want to integrate case filings into their apps.

## LAW FIRMS

Build custom dashboards for your attorneys and clients with live data direct from the court.

Automate many repetitive legal tasks like conflict checks, document management, and marketing.

## FINANCIAL INSTITUTIONS

Litigation and bankruptcy checks for companies and debtors.

## E-DISCOVERY AND LEGAL VENDORS

Sync your system to PACER to automate legal marketing.