



FUNDAMENTALS OF TELECOMMUNICATIONS

ROGER L. FREEMAN

Wiley Series in Telecommunications and Signal Processing
John G. Proakis, Series Editor

IBM EX. 1024

The texts extracted from the ITU material have been reproduced with the prior authorization of the Union as the copyright holder. The sole responsibility for selecting extracts for reproduction lies with the author alone and can in no way be attributed to the ITU. The complete volumes of the ITU material from which the texts reproduced here are extracted, can be obtained from

International Telecommunication Union
General Secretariat—Sales and Marketing Service
Place de Nations
CH-1211 GENEVA 20 (Switzerland)
Telephone: +41 22 730 51 11 Telex: 421 000 itu ch Telegram: ITU GENEVE Fax: +41 22
730 51 94 X.400: S = Sales; P = itu; A = Arcom; C = ch Internet: Sales@itu.ch

As referenced, some figures and tables throughout this text are copyrighted by The Institute of Electrical and Electronics Engineers, Inc. The IEEE disclaims any responsibility or liability resulting from the placement and use in this publication. All figures are reprinted with permission.

As referenced, some figures and tables are copyrighted by Bellcore and are reprinted with permission.

This book is printed on acid-free paper. ☺

Copyright © 1999 by Roger L. Freeman

Published by John Wiley & Sons, Inc.
Published simultaneously in Canada.

No part of this publication may be reproduced, stored in a retrieval system or transmitted in any form or by any means, electronic, mechanical, photocopying, recording, scanning or otherwise, except as permitted under Sections 107 or 108 of the 1976 United States Copyright Act, without either the prior written permission of the Publisher, or authorization through payment of the appropriate per-copy fee to the Copyright Clearance Center, 222 Rosewood Drive, Danvers, MA 01923, (978)750-8400, fax (978)750-4744. Requests to the Publisher for permission should be addressed to the Permissions Department, John Wiley & Sons, Inc., 605 Third Avenue, New York, NY 10158-0012, (212)850-6011, fax (212)850-6008, E-Mail: PERMREQ @ WILEY.COM.

For ordering and customer information call, 1-800-CALL-WILEY.

Library of Congress Cataloging-in-Publication Data:

Freeman, Roger L.
Fundamentals of telecommunications / Roger L. Freeman.
p. cm.
"A Wiley-Interscience publication."
Includes index.
ISBN 0-471-29699-6 (cloth : alk. paper)
1. Telecommunication. I. Title.
TK5101.F6595 1999
621.382—dc21

98-4272
CIP

Printed in the United States of America.

10 9 8 7 6 5 4

INTRODUCTORY CONCEPTS

1.1 WHAT IS TELECOMMUNICATION?

Many people call *telecommunication* the world's most lucrative industry. If we add cellular and PCS users,¹ there are about 1800 million subscribers to telecommunication services world wide (1999). Annual expenditures on telecommunications may reach 900,000 million dollars in the year 2000.²

Prior to divestiture, the *Bell System* was the largest commercial company in the United States even though it could not be found on the Fortune 500 listing of the largest companies. It had the biggest fleet of vehicles, the most employees, and the greatest income. Every retiree with any sense held the safe and dependable Bell stock. In 1982, Western Electric Co., the Bell System manufacturing arm, was number seven on the Fortune 500. However, if one checked the Fortune 100 Utilities, the Bell System was up on the top. Transferring this information to the Fortune 500, again put Bell System as the leader on the list.

We know telecommunication is big business; but what is it? *Webster's* (Ref. 1) calls it *communications at a distance*. The IEEE dictionary (Ref. 2) defines telecommunications as "the transmission of signals over long distance, such as by telegraph, radio or television." Another term we often hear is *electrical communication*. This is a descriptive term, but of somewhat broader scope.

Some take the view that telecommunication deals only with voice telephony, and the typical provider of this service is the local telephone company. We hold with a wider interpretation. Telecommunication encompasses the electrical communication at a distance of voice, data, and image information (e.g., TV and facsimile). These media, therefore, will be major topics of this book. The word *media* (medium, singular) also is used to describe what is transporting telecommunication signals. This is termed transmission media. There are four basic types of medium: (1) wire-pair, (2) coaxial cable, (3) fiber optics, and (4) radio.

1.2 TELECOMMUNICATION WILL TOUCH EVERYBODY

In industrialized nations, the telephone is accepted as a way of life. The telephone is connected to the public switched telecommunications network (PSTN) for local, national,

¹PCS, personal communication services, is a cellular-radiolike service covering a smaller operational area.

²We refrain from using *billion* because it is ambiguous. Its value differs, depending on where you come from.

and international voice communications. These same telephone connections may also carry data and image information (e.g., television).

The personal computer (PC) is beginning to take on a similar role as the telephone, that of being ubiquitous. Of course, as we know, the two are becoming married. In most situations, the PC uses telephone connectivity to obtain internet and e-mail services. Radio adjuncts to the telephone, typically cellular and PCS, are beginning to offer similar services such as data communications (including internet) and facsimile (fax), as well as voice. The popular press calls these adjuncts *wireless*. Can we consider wireless in opposition to *being wired*?

Count the number of devices one has at home that carry out some kind of controlling or alerting function. They also carry out a personal communication service. Among these devices are television remote controls, garage-door openers, VCR and remote radio and CD player controllers, certain types of home security systems, pagers, and cordless telephones. We even take cellular radios for granted.

In some countries, a potential subscriber has to wait months or years for a telephone. Cellular radio, in many cases, provides a way around the problem, where equivalent telephone service can be established in an hour—just enough time to buy a cellular radio in the local store and sign a contract for service.

The PSTN has ever-increasing data communications traffic, where the network is used as a conduit for data. PSTN circuits may be leased or used in a dial-up mode for data connections. Of course, the Internet has given added stimulus to data circuit usage of the PSTN. The PSTN sees facsimile as just another data circuit, usually in the dial-up mode. Conference television traffic adds still another flavor to PSTN traffic and is also a major growth segment.

There is a growing trend for users to bypass the PSTN partially or completely. The use of satellite links in certain situations is one method for PSTN bypass. Another is to lease capacity from some other provider. *Other provider* could be a power company with excess capacity on its microwave or fiber optic system. There are other examples, such as a railroad with extensive rights-of-way that are used by a fiber optic network.

Another possibility is to build a private network using any one or a combination of fiber optics, line-of-sight-microwave, and satellite communications. Some private networks take on the appearance of a mini-PSTN.

1.3 INTRODUCTORY TOPICS IN TELECOMMUNICATIONS

An overall telecommunications network (i.e., the PSTN) consists of local networks interconnected by a long-distance network. The concept is illustrated in Figure 1.1. This is the PSTN, which is open to public correspondence. It is usually regulated by a government authority or may be a government monopoly, although there is a notable trend toward privatization. In the United States the PSTN has been a commercial enterprise since its inception.

1.3.1 End-Users, Nodes, and Connectivities

End-users, as the term tells us, provide the inputs to the network and are recipients of network outputs. The end-user employs what is called an I/O, standing for input/output (device). An I/O may be a PC, computer, telephone instrument, cellular/PCS telephone or combined device, facsimile, or conference TV equipment. It may also be some type

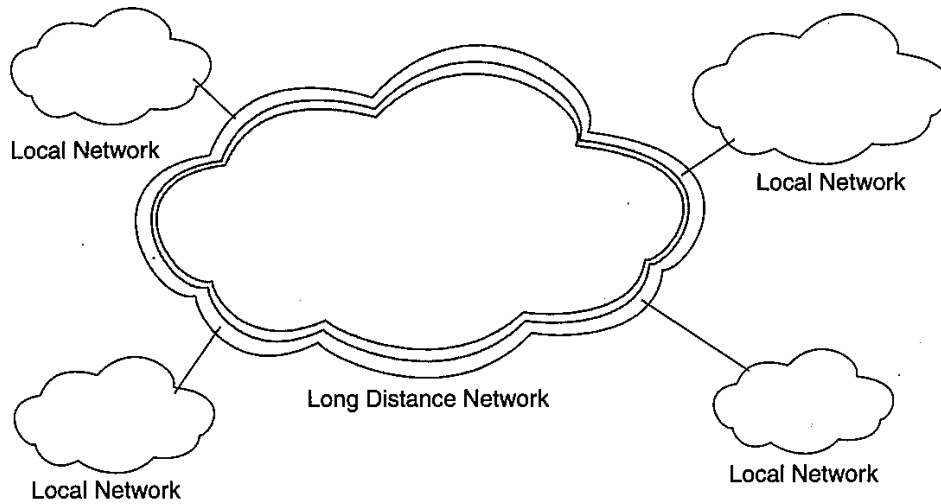

Figure 1.1 The PSTN consists of local networks interconnected by a long-distance network.

of *machine* that provides a stimulus to a coder or receives stimulus from a decoder in, say, some sort of SCADA system.³

End-users usually connect to *nodes*. We will call a node a point or junction in a transmission system where lines and trunks meet. A node usually carries out a switching function. In the case of the local area network (LAN), we are stretching the definition. In this case a network interface unit is used, through which one or more end-users may be connected.

A *connectivity* connects an end-user to a node, and from there possibly through other nodes to some final end-user destination with which the initiating end-user wants to communicate. Figure 1.2 illustrates this concept.

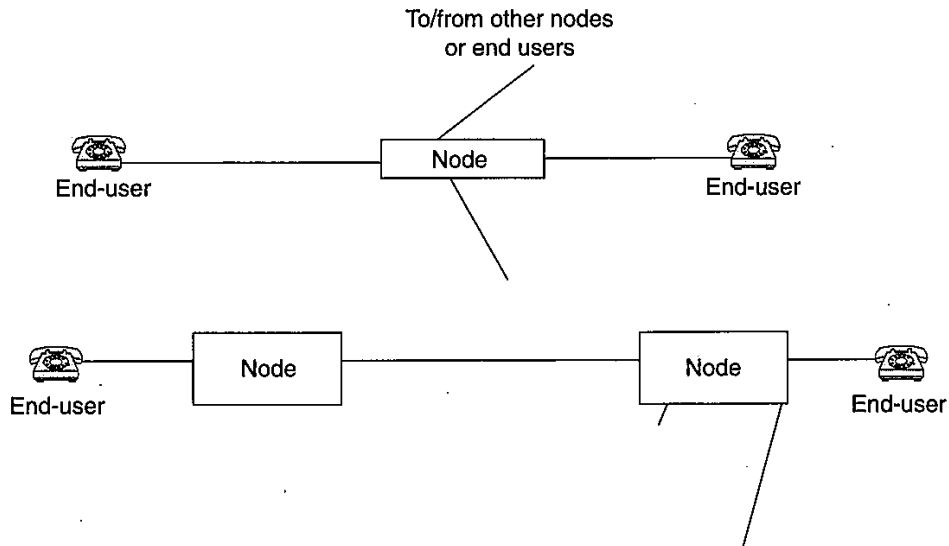

Figure 1.2 Illustrating the functions of end-users, nodes, and connectivity.

³SCADA stands for supervisory control and data acquisition.

Explore Litigation Insights

Docket Alarm provides insights to develop a more informed litigation strategy and the peace of mind of knowing you're on top of things.

Real-Time Litigation Alerts



Keep your litigation team up-to-date with **real-time alerts** and advanced team management tools built for the enterprise, all while greatly reducing PACER spend.

Our comprehensive service means we can handle Federal, State, and Administrative courts across the country.

Advanced Docket Research



With over 230 million records, Docket Alarm's cloud-native docket research platform finds what other services can't. Coverage includes Federal, State, plus PTAB, TTAB, ITC and NLRB decisions, all in one place.

Identify arguments that have been successful in the past with full text, pinpoint searching. Link to case law cited within any court document via Fastcase.

Analytics At Your Fingertips



Learn what happened the last time a particular judge, opposing counsel or company faced cases similar to yours.

Advanced out-of-the-box PTAB and TTAB analytics are always at your fingertips.

API

Docket Alarm offers a powerful API (application programming interface) to developers that want to integrate case filings into their apps.

LAW FIRMS

Build custom dashboards for your attorneys and clients with live data direct from the court.

Automate many repetitive legal tasks like conflict checks, document management, and marketing.

FINANCIAL INSTITUTIONS

Litigation and bankruptcy checks for companies and debtors.

E-DISCOVERY AND LEGAL VENDORS

Sync your system to PACER to automate legal marketing.