

Doc code: IDS
 Doc description: Information Disclosure Statement (IDS) Filed

PTO/SB/08a (01-10)
 Approved for use through 07/31/2012. OMB 0651-0031
 U.S. Patent and Trademark Office; U.S. DEPARTMENT OF COMMERCE
 Under the Paperwork Reduction Act of 1995, no persons are required to respond to a collection of information unless it contains a valid OMB control number.

INFORMATION DISCLOSURE STATEMENT BY APPLICANT (Not for submission under 37 CFR 1.99)	Application Number		
	Filing Date		2011-12-05
	First Named Inventor	Wood, et al.	
	Art Unit		
	Examiner Name		
	Attorney Docket Number		ENIT 9834C2

U.S. PATENTS						Remove
Examiner Initial*	Cite No	Patent Number	Kind Code ¹	Issue Date	Name of Patentee or Applicant of cited Document	Pages, Columns, Lines where Relevant Passages or Relevant Figures Appear
	1	4415771		1983-11-15	Martinez	
	2	5278539		1994-01-11	Lauterbach, et al.	
	3	5592172		1997-01-07	Bailey, et al.	
	4	6021177		2000-02-01	Allport	
	5	6084510		2000-07-04	Lemelson, et al.	
	6	6112075		2000-08-29	Weiser	
	7	6169476	B1	2001-01-02	Flanagan	
	8	6219696	B1	2001-04-17	Wynblatt, et al.	

INFORMATION DISCLOSURE STATEMENT BY APPLICANT (Not for submission under 37 CFR 1.99)	Application Number			
	Filing Date		2011-12-05	
	First Named Inventor	Wood, et al.		
	Art Unit			
	Examiner Name			
	Attorney Docket Number		ENIT 9834C2	

	9	6240360	B1	2001-05-29	Phelan	
	10	6346890	B1	2002-02-12	Belin	
	11	6463273	B1	2002-10-08	Day	
	12	6480578	B1	2002-11-12	Allport	
	13	6490525	B2	2002-12-03	Baron, Sr. et al.	
	14	6493633	B2	2002-12-10	Baron, Sr. et al.	
	15	6580916	B1	2003-06-17	Weisshaar, et al.	
	16	6650902	B1	2003-11-18	Richton	
	17	6683526	B2	2004-01-27	Bellin	
	18	6745021	B1	2004-06-01	Stevens	
	19	6751455	B1	2004-06-15	Acampora	

**INFORMATION DISCLOSURE
STATEMENT BY APPLICANT**
(Not for submission under 37 CFR 1.99)

Application Number		
Filing Date		2011-12-05
First Named Inventor	Wood, et al.	
Art Unit		
Examiner Name		
Attorney Docket Number		ENIT 9834C2

20	6753784	B1	2004-06-22	Sznaider, et al.	
21	6785551	B1	2004-08-31	Richard	
22	6867688	B2	2005-03-15	Lamb	
23	6882837	B2	2005-04-19	Fernandez, et al.	
24	6947754	B2	2005-09-20	Ogasawara	
25	4887308		1989-12-12	Dutton	
26	6721542		2004-04-13	Anttila, et al.	
27	6766163		2004-07-20	Sharma	

If you wish to add additional U.S. Patent citation information please click the Add button. **Add**

U.S.PATENT APPLICATION PUBLICATIONS Remove

Examiner Initial*	Cite No	Publication Number	Kind Code ¹	Publication Date	Name of Patentee or Applicant of cited Document	Pages, Columns, Lines where Relevant Passages or Relevant Figures Appear
	1	20020107016	A1	2002-08-08	Hanley	

INFORMATION DISCLOSURE STATEMENT BY APPLICANT (Not for submission under 37 CFR 1.99)	Application Number		
	Filing Date		2011-12-05
	First Named Inventor	Wood, et al.	
	Art Unit		
	Examiner Name		
	Attorney Docket Number		ENIT 9834C2

	2	20020124252	A1	2002-09-05	Schafer, et al.	
	3	20020095333	A1	2002-07-18	Jokinen, et al.	
	4	20030026240	A1	2003-02-06	Eyuboglu, et al.	
	5	20030134622	A1	2003-07-17	Hsu, et al.	
	6	20030134651	A1	2003-07-17	Hsu	
	7	20030137415	A1	2003-07-24	Thomson	
	8	20030197615	A1	2003-10-23	Roche, et al.	
	9	20030145064	A1	2003-07-31	Hsu, et al.	
	10	20040150518	A1	2004-08-05	Phillips, et al.	
	11	20040152493	A1	2004-08-05	Phillips, et al.	
	12	20040247086	A1	2004-12-09	Menard, et al.	

INFORMATION DISCLOSURE STATEMENT BY APPLICANT (Not for submission under 37 CFR 1.99)	Application Number			
	Filing Date		2011-12-05	
	First Named Inventor	Wood, et al.		
	Art Unit			
	Examiner Name			
	Attorney Docket Number		ENIT 9834C2	

	13	20050030977	A1	2005-02-10	Casey, et al.	
	14	20050162267	A1	2005-07-28	Khandelwal, et al.	
	15	20050096065	A1	2005-05-05	Fleischman	
	16	20050261012	A1	2005-11-24	Weiser	

If you wish to add additional U.S. Published Application citation information please click the Add button. **Add**

FOREIGN PATENT DOCUMENTS Remove

Examiner Initial*	Cite No	Foreign Document Number ³	Country Code ² j	Kind Code ⁴	Publication Date	Name of Patentee or Applicant of cited Document	Pages, Columns, Lines where Relevant Passages or Relevant Figures Appear	T ⁵
	1	2000244427	JP		2000-09-08			<input type="checkbox"/>
	2	10336127	JP		1998-12-18			<input type="checkbox"/>
	3	441719	JP		1999-09-28			<input type="checkbox"/>
	4	09098140	JP		1997-04-08			<input type="checkbox"/>
	5	2000165826	JP		2000-06-16			<input type="checkbox"/>

If you wish to add additional Foreign Patent Document citation information please click the Add button **Add**

INFORMATION DISCLOSURE STATEMENT BY APPLICANT (Not for submission under 37 CFR 1.99)	Application Number			
	Filing Date		2011-12-05	
	First Named Inventor	Wood, et al.		
	Art Unit			
	Examiner Name			
	Attorney Docket Number		ENIT 9834C2	

NON-PATENT LITERATURE DOCUMENTS			Remove
Examiner Initials*	Cite No	Include name of the author (in CAPITAL LETTERS), title of the article (when appropriate), title of the item (book, magazine, journal, serial, symposium, catalog, etc), date, pages(s), volume-issue number(s), publisher, city and/or country where published.	T ⁵
	1		<input type="checkbox"/>
If you wish to add additional non-patent literature document citation information please click the Add button			Add
EXAMINER SIGNATURE			
Examiner Signature		Date Considered	
*EXAMINER: Initial if reference considered, whether or not citation is in conformance with MPEP 609. Draw line through a citation if not in conformance and not considered. Include copy of this form with next communication to applicant.			
<small> ¹ See Kind Codes of USPTO Patent Documents at www.USPTO.GOV or MPEP 901.04. ² Enter office that issued the document, by the two-letter code (WIPO Standard ST.3). ³ For Japanese patent documents, the indication of the year of the reign of the Emperor must precede the serial number of the patent document. ⁴ Kind of document by the appropriate symbols as indicated on the document under WIPO Standard ST.16 if possible. ⁵ Applicant is to place a check mark here if English language translation is attached. </small>			

INFORMATION DISCLOSURE STATEMENT BY APPLICANT (Not for submission under 37 CFR 1.99)	Application Number		
	Filing Date		2011-12-05
	First Named Inventor	Wood, et al.	
	Art Unit		
	Examiner Name		
	Attorney Docket Number		ENIT 9834C2

CERTIFICATION STATEMENT

Please see 37 CFR 1.97 and 1.98 to make the appropriate selection(s):

That each item of information contained in the information disclosure statement was first cited in any communication from a foreign patent office in a counterpart foreign application not more than three months prior to the filing of the information disclosure statement. See 37 CFR 1.97(e)(1).

OR

That no item of information contained in the information disclosure statement was cited in a communication from a foreign patent office in a counterpart foreign application, and, to the knowledge of the person signing the certification after making reasonable inquiry, no item of information contained in the information disclosure statement was known to any individual designated in 37 CFR 1.56(c) more than three months prior to the filing of the information disclosure statement. See 37 CFR 1.97(e)(2).

- See attached certification statement.
- The fee set forth in 37 CFR 1.17 (p) has been submitted herewith.
- A certification statement is not submitted herewith.

SIGNATURE

A signature of the applicant or representative is required in accordance with CFR 1.33, 10.18. Please see CFR 1.4(d) for the form of the signature.

Signature	/David L. Howard/	Date (YYYY-MM-DD)	2011-12-05
Name/Print	David L. Howard	Registration Number	41502

This collection of information is required by 37 CFR 1.97 and 1.98. The information is required to obtain or retain a benefit by the public which is to file (and by the USPTO to process) an application. Confidentiality is governed by 35 U.S.C. 122 and 37 CFR 1.14. This collection is estimated to take 1 hour to complete, including gathering, preparing and submitting the completed application form to the USPTO. Time will vary depending upon the individual case. Any comments on the amount of time you require to complete this form and/or suggestions for reducing this burden, should be sent to the Chief Information Officer, U.S. Patent and Trademark Office, U.S. Department of Commerce, P.O. Box 1450, Alexandria, VA 22313-1450. **DO NOT SEND FEES OR COMPLETED FORMS TO THIS ADDRESS. SEND TO: Commissioner for Patents, P.O. Box 1450, Alexandria, VA 22313-1450.**

Privacy Act Statement

The Privacy Act of 1974 (P.L. 93-579) requires that you be given certain information in connection with your submission of the attached form related to a patent application or patent. Accordingly, pursuant to the requirements of the Act, please be advised that: (1) the general authority for the collection of this information is 35 U.S.C. 2(b)(2); (2) furnishing of the information solicited is voluntary; and (3) the principal purpose for which the information is used by the U.S. Patent and Trademark Office is to process and/or examine your submission related to a patent application or patent. If you do not furnish the requested information, the U.S. Patent and Trademark Office may not be able to process and/or examine your submission, which may result in termination of proceedings or abandonment of the application or expiration of the patent.

The information provided by you in this form will be subject to the following routine uses:

1. The information on this form will be treated confidentially to the extent allowed under the Freedom of Information Act (5 U.S.C. 552) and the Privacy Act (5 U.S.C. 552a). Records from this system of records may be disclosed to the Department of Justice to determine whether the Freedom of Information Act requires disclosure of these records.
2. A record from this system of records may be disclosed, as a routine use, in the course of presenting evidence to a court, magistrate, or administrative tribunal, including disclosures to opposing counsel in the course of settlement negotiations.
3. A record in this system of records may be disclosed, as a routine use, to a Member of Congress submitting a request involving an individual, to whom the record pertains, when the individual has requested assistance from the Member with respect to the subject matter of the record.
4. A record in this system of records may be disclosed, as a routine use, to a contractor of the Agency having need for the information in order to perform a contract. Recipients of information shall be required to comply with the requirements of the Privacy Act of 1974, as amended, pursuant to 5 U.S.C. 552a(m).
5. A record related to an International Application filed under the Patent Cooperation Treaty in this system of records may be disclosed, as a routine use, to the International Bureau of the World Intellectual Property Organization, pursuant to the Patent Cooperation Treaty.
6. A record in this system of records may be disclosed, as a routine use, to another federal agency for purposes of National Security review (35 U.S.C. 181) and for review pursuant to the Atomic Energy Act (42 U.S.C. 218(c)).
7. A record from this system of records may be disclosed, as a routine use, to the Administrator, General Services, or his/her designee, during an inspection of records conducted by GSA as part of that agency's responsibility to recommend improvements in records management practices and programs, under authority of 44 U.S.C. 2904 and 2906. Such disclosure shall be made in accordance with the GSA regulations governing inspection of records for this purpose, and any other relevant (i.e., GSA or Commerce) directive. Such disclosure shall not be used to make determinations about individuals.
8. A record from this system of records may be disclosed, as a routine use, to the public after either publication of the application pursuant to 35 U.S.C. 122(b) or issuance of a patent pursuant to 35 U.S.C. 151. Further, a record may be disclosed, subject to the limitations of 37 CFR 1.14, as a routine use, to the public if the record was filed in an application which became abandoned or in which the proceedings were terminated and which application is referenced by either a published application, an application open to public inspections or an issued patent.
9. A record from this system of records may be disclosed, as a routine use, to a Federal, State, or local law enforcement agency, if the USPTO becomes aware of a violation or potential violation of law or regulation.

(19) 日本国特許庁 (J P)

(12) 公開特許公報 (A)

(11) 特許出願公開番号

特開2000-244427

(P2000-244427A)

(43) 公開日 平成12年9月8日(2000.9.8)

(51) Int.Cl. ⁷	識別記号	F I	テマコード*(参考)
H 0 4 H 1/00		H 0 4 H 1/00	A
G 0 6 F 13/00	3 5 4	G 0 6 F 13/00	3 5 4 D
H 0 4 B 1/16		H 0 4 B 1/16	G
H 0 4 N 5/222		H 0 4 N 5/222	Z

審査請求 有 請求項の数17 O L (全 5 頁) 最終頁に続く

(21) 出願番号	特願平11-183558	(71) 出願人	599090741 アドベント テレビジョン リミテッド Advent Television L t d. シンガポール共和国 298135, トムソン ロード ナンバー12-04 510, エスエル エフ ビルディング
(22) 出願日	平成11年6月29日(1999.6.29)	(74) 代理人	100077931 弁理士 前田 弘 (外4名)
(31) 優先権主張番号	9 9 0 0 0 5 1 - 5		
(32) 優先日	平成11年2月15日(1999.2.15)		
(33) 優先権主張国	シンガポール (S G)		

最終頁に続く

(54) 【発明の名称】 電子広告掲載放送システム

(57) 【要約】

【課題】 少量の個人的な広告にも適した安価な電子広告掲載放送システムを提供する。

【解決手段】 広告掲載放送システム10は、複数のネットワーク接続コンピュータ20を介してアクセス可能で、広告に関するデータを受信し、そのデータの有効性を検査し、有効なデータを少なくとも一つの処理手段14、16、18に送信するデータサーバ12と、それぞれ対応するメディア放送システム14a、16a、18aと連係されていて、有効なデータにより表現された広告を少なくとも一回の放送時間に割り当てるとともに各放送時間に上記有効なデータをレイアウト生成手段28、30、32に送信するよう構成された上記処理手段14、16、18と、上記有効なデータに回答して広告表示を作成し、この広告表示を上記メディア放送システム14a、16a、18aによって放送されるメディア表示14b、16b、18bと結合させる上記レイアウト生成手段28、30、32とを備える。

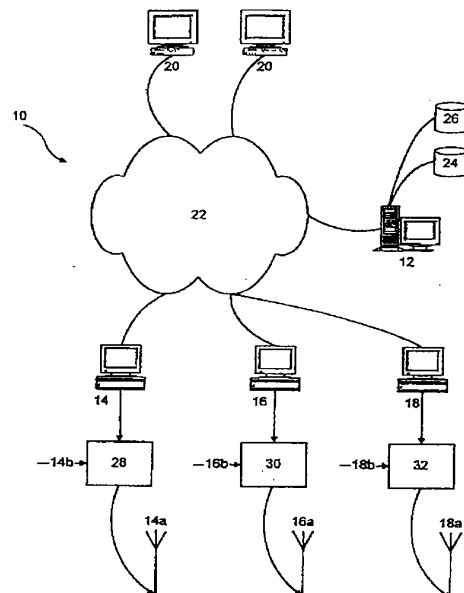

【特許請求の範囲】

【請求項 1】 複数のネットワーク接続コンピュータを介してアクセス可能で、広告に関するデータを受信し、そのデータの有効性を検査し、有効なデータを少なくとも一つの処理手段に送信するデータサーバと、それぞれ対応するメディア放送システムと連係されていて、有効なデータにより表現された広告を少なくとも一回の放送時間に割り当てるとともに各放送時間に上記有効なデータをレイアウト生成手段に送信するよう構成された上記処理手段と、

上記有効なデータに回答して広告表示を作成し、この広告表示を上記メディア放送システムによって放送されるメディア表示と結合させる上記レイアウト生成手段とを備えた広告掲載放送システム。

【請求項 2】 上記データサーバが広告主によるクリップアートの選択を可能にするクリップアート集を有している請求項 1 記載の広告掲載放送システム。

【請求項 3】 上記データが、文字記述と、支払情報と、選択されたクリップアートと、広告提供地域に関する情報と、広告回数に関する情報とを含んでいる請求項 1 または 2 記載の広告掲載放送システム。

【請求項 4】 上記データサーバが上記文字記述から所定の言葉を除外するよう構成されたフィルタ手段を有している請求項 1 ないし 3 のいずれかに記載の広告掲載放送システム。

【請求項 5】 上記フィルタ手段が上記文字記述の中から放送禁止用語リスト上の言葉を検索するようになっている請求項 4 記載の広告掲載放送システム。

【請求項 6】 上記フィルタ手段が上記文字記述が所定の数を超える放送禁止用語を含んでいる場合にその広告を拒絶するよう構成されている請求項 5 記載の広告掲載放送システム。

【請求項 7】 上記データサーバが支払情報が有効であることを確認する財務検査手段を有している請求項 1 ないし 6 のいずれかに記載の広告掲載放送システム。

【請求項 8】 上記財務検査手段が少なくとも上記広告提供地域及び広告回数に関する情報から広告費を算出するようになっている請求項 7 記載の広告掲載放送システム。

【請求項 9】 上記財務検査手段が、上記データを検査する前に、算出された費用の支払いを得るようになっている請求項 8 記載の広告掲載放送システム。

【請求項 10】 上記データサーバが、上記広告提供地域で作動するメディア放送システムと連係された少なくとも一つの処理手段に対して上記有効なデータを送信するよう構成されている請求項 1 ないし 9 のいずれかに記載の広告掲載放送システム。

【請求項 11】 上記データサーバが上記複数のネットワーク接続コンピュータを介してアクセス可能な広告の記憶装置を有している請求項 1 ないし 10 のいずれかに

記載の広告掲載放送システム。

【請求項 12】 上記データサーバが有効なデータに対応する広告を上記記憶装置に格納するよう構成されている請求項 1 記載の広告掲載放送システム。

【請求項 13】 上記メディア放送システムがテレビ放送局からなる請求項 1 ないし 12 のいずれかに記載の広告掲載放送システム。

【請求項 14】 上記テレビ放送局がデジタルテレビ放送局からなる請求項 13 記載の広告掲載放送システム。

10 【請求項 15】 上記メディア表示がテレビ画像からなる請求項 13 または 14 記載の広告掲載放送システム。

【請求項 16】 上記メディア表示及び広告表示がテレビ画面上で別々の領域を有している請求項 15 記載の広告掲載放送システム。

【請求項 17】 上記広告表示が上記メディア表示に重ね合わされている請求項 15 記載の広告掲載放送システム。

【発明の詳細な説明】

【0001】

20 【発明の属する技術分野】本発明は広告の電子掲載放送システムに関し、特に、それに限るものではないが、テレビによる広告放送に適している。

【0002】

【従来の技術及び発明が解決しようとする課題】現在、広告は新聞やテレビ放送を含む多数の様々なタイプのメディアで掲載されている。

【0003】新聞に広告を掲載する費用は比較的安い。しかし、新聞広告は視覚的な魅力に欠ける傾向があり、大量の文字から構成されるのが一般的である。新聞広告に図柄などの材料を加えると、広告費が大幅に上昇することになる。

【0004】テレビ放送広告の場合は制作費も放送費も比較的高い。このような事情により、一般に、テレビ放送広告は少量の個人的な広告には向いていない。

【0005】テレビ放送広告は、1台のテレビ受像器を見ている複数の人間に届くという利点がある。さらに、テレビ放送広告は印刷された文字よりも活力があり、気軽に見ているだけの人の注目も受けやすい。

40 【0006】本発明は上記の点に鑑みてなされたものであり、その目的とするところは、少量の個人的な広告にも適した安価な電子広告掲載放送システムを提供することである。

【0007】

【課題を解決するための手段】上記の目的を達成するため、本発明の第一の特徴は、複数のネットワーク接続コンピュータを介してアクセス可能で、広告に関するデータを受信し、そのデータの有効性を検査し、有効なデータを少なくとも一つの処理手段に送信するデータサーバと、それぞれ対応するメディア放送システムと連係されていて、有効なデータにより表現された広告を少なくと

も一回の放送時間に割り当てるとともに各放送時間に上記有効なデータをレイアウト生成手段に送信するよう構成された上記処理手段と、上記有効なデータにตอบสนองして広告表示を作成し、この広告表示を上記メディア放送システムによって放送されるメディア表示と結合させる上記レイアウト生成手段とを備えた広告掲載放送システムを提供するものである。

【0008】上記データサーバは広告主によるクリップアートの選択を可能にするクリップアート集を有していることが好ましい。

【0009】上記データは、文字記述と、支払情報と、選択されたクリップアートと、広告提供地域に関する情報と、広告回数に関する情報とを含んでいることが好ましい。

【0010】上記データサーバは上記文字記述から所定の言葉を除外するよう構成されたフィルタ手段を有していることが好ましい。

【0011】上記フィルタ手段は上記文字記述の中から放送禁止用語リスト上の言葉を検索するようになっていることが好ましい。

【0012】上記フィルタ手段は、上記文字記述が所定の数を超える放送禁止用語を含んでいる場合にその広告を拒絶するよう構成されているもよい。

【0013】上記データサーバは支払情報が有効であることを確認する財務検査手段を有していることが好ましい。

【0014】上記財務検査手段は少なくとも上記広告提供地域及び広告回数に関する情報から広告費を算出するようになっていることが好ましい。

【0015】上記財務検査手段は、上記データを検査する前に、算出された費用の支払いを得るようになっていることが好ましい。

【0016】上記データサーバは、上記広告提供地域で作動するメディア放送システムと連係された少なくとも一つの処理手段に対して上記有効なデータを送信するよう構成されていることが好ましい。

【0017】上記データサーバは上記複数のネットワーク接続コンピュータを介してアクセス可能な広告の記憶装置を有していることが好ましい。

【0018】上記データサーバは有効なデータに対応する広告を上記記憶装置に格納するよう構成されていることが好ましい。

【0019】上記メディア放送システムはテレビ放送局からなることが好ましい。

【0020】上記テレビ放送局はデジタルテレビ放送局からなることが好ましい。

【0021】上記メディア表示はテレビ画像からなることが好ましい。

【0022】上記メディア表示及び広告表示はテレビ画面上で別々の領域を有していることが好ましい。

【0023】あるいは、上記広告表示は上記メディア表示に重ね合わされてもよい。

【0024】

【発明の実施の形態】本発明をその実施の形態及び実施の形態を示す図面を参照しながら説明する。

【0025】本実施の形態は広告掲載放送システム10を対象とする。このシステム10は、データサーバとしての第1コンピュータ12と、処理手段としての3個の第2コンピュータ14、16、18とを備えている。各第2コンピュータ14、16、18はそれぞれ対応するデジタルテレビ放送システム14a、16a、18aと連係されている。

【0026】第1コンピュータ12は複数のネットワーク接続コンピュータ20を介してアクセス可能になっている。第1コンピュータ12及びネットワーク接続コンピュータ20は、MAN（都市圏ネットワーク）、WAN（広域ネットワーク）、インターネットなどの適切な手段によりネットワーク間接続されている。図中、22はネットワークを示す。

【0027】第1コンピュータ12はどのネットワーク接続コンピュータ20からもアクセス可能な広告掲載機能を有している。一部の実施形態においては、この広告掲載機能はインターネット上のホームページであると考えられる。

【0028】利用者は、第1コンピュータ12の広告掲載機能にアクセスして、自らの広告に関するデータを入力することができる。データを提出することによって、利用者は広告が放送されることを依頼していることとなる。そのデータは以下の内容を含んでいる。

【0029】1. 文字記述。広告の中核部分を構成する。

【0030】2. クレジットカードの番号、有効期限及び種類からなる支払情報。

【0031】3. 利用者が選択したクリップアート。第1コンピュータ12は利用者が選択可能なクリップアートを収めた第1記憶装置24を有している。

【0032】4. リストから選択された広告提供地域の情報。このリストには、デジタルテレビ放送システム14a、16a、18aの視聴可能地域によって決定された、広告が放送可能な地域が列挙されている。利用者は、条件に応じて上記リストから一つ以上の地域を選択する。

【0033】5. 日付を含む広告回数の情報。この情報は利用者によって入力される。好ましくは、日付以外の広告回数の情報がリストから選択される。これにより、リスト上の各項目に対して所定の費用を割り当てることができる。広告は、例えば、一地域あたり15ドルで毎日少なくとも4回放送されたり、一地域あたり40ドルで1時間に1回放送されたりする。その情報を利用者に提供するために様々な方法が採用可能であると考えられ

る。広告が放送される時間帯を利用者が指定できるようにすることも考えられる。

【0034】6. 電子メールアドレス。これは必要不可欠ではないが、これによりシステム10は利用者に対してその広告に関する実行結果を提供することができる。

【0035】その後、第1コンピュータ12は以下のようにしてデータの有効性を検査する。まず、文字記述をフィルタに通して放送禁止用語を取り除く。これは、望ましくない素材を確実に放送しないようにするためである。フィルタは、文字記述内の各言葉とリスト上の放送禁止用語との間で逐語比較を行ったり音声上の比較を行ったりなど、複数の方式を採用することができる。

【0036】文字記述が所定数を超える放送禁止用語を含んでいる場合、その広告は拒絶される。その利用者が電子メールアドレスを提供していれば、利用者に対して拒絶を通知するメッセージが発送される。

【0037】そのメッセージが却下されなければ、第1コンピュータ12は提出されたデータから広告費を算出する。その費用は広告提供地域、広告回数の情報、クリップアートが選択されたか否かなどの情報に基づく。

【0038】次に、第1コンピュータ12は支払情報の有効性を検査する。好ましくは、この検査は、第1コンピュータ12が算出費用をクレジットカードから支払わせることによって行われる。支払いが拒否された場合は、広告も拒絶され、利用者にもそのメッセージが発送される。

【0039】文字記述と支払情報が無事に有効とされると、第1コンピュータ12は、フィルタに通した文字記述と、利用者が選択したクリップアートと、広告提供地域の情報と、広告回数の情報と、電子メールアドレスとからなる有効なデータを作成する。そして、有効なデータは、広告提供地域の情報に基づいて該当する第2コンピュータ14、16、18に送信される。便宜性を考慮して、第2コンピュータ14、16、18もネットワーク22と接続されている。あるいは、別の実施の形態では、他の手段により第2コンピュータ14、16、18が第1コンピュータ12と通信状態になっていてもよい。

【0040】第1コンピュータ12は有効とされた広告を収めた第2記憶装置26を有している。第2記憶装置26内の広告はインターネット22を介してネットワーク接続コンピュータ20からアクセス可能である。第2記憶装置26には、利用者がアクセスするための検索機能が設けられていることが好ましい。

【0041】第2コンピュータ14、16、18は、それぞれ該当するデジタルテレビ放送システム14a、16a、18aの視聴可能地域と対応する広告提供地域の情報を有する広告に関して第1コンピュータ12から有効なデータを受信する。

【0042】第2コンピュータ14、16、18は、そ

れぞれ受信した有効なデータを同じやり方で処理する。以下の説明は第2コンピュータ14に関してなされたものであるが、他の第2コンピュータ16、18にも適用可能である。

【0043】第2コンピュータ14が第1コンピュータ12から新しい有効なデータを受信すると、有効なデータは以下のように処理される。

【0044】すなわち、第2コンピュータ14は、広告回数の情報を分析して広告が放送される回数、放送期日などを求める。そして、第2コンピュータ14は、新しい有効なデータの期日に関係する既に受信した他の全ての有効なデータの広告回数の情報を読みとる。

【0045】その後、第2コンピュータ14は広告のスケジュールを決め、特定の放送時間に各広告を割り当てる。これらの放送時間は各広告に関する有効なデータとともに第2コンピュータ14に記憶される。第2コンピュータ14がある時間帯の予定が詰まっていると判断すれば、第1コンピュータ12と通信して以後の利用者がその予定の詰まった時間帯を選択できないようにする。

【0046】広告の放送時間になると、第2コンピュータ14は有効なデータをレイアウト生成装置28に送信する。広告の利用者が電子メールアドレスを指定していれば、第2コンピュータ14は、その利用者に対して広告が放送された時間を確認するメッセージを送付する。第2コンピュータ16、18はそれぞれレイアウト生成装置30、32と通信する。

【0047】レイアウト生成装置28は、第2コンピュータ14からの有効なデータと、デジタルテレビ放送局14aにより送信される図示14bのデジタルテレビ画像を受信する。同様に、デジタルテレビ放送局16a、18aにより送信されるデジタルテレビ画像をそれぞれ16b、18bで示す。

【0048】レイアウト生成装置28は有効なデータから広告表示を作成する。この広告表示はデジタルテレビ画像14bと結合される。結合された広告表示はデジタルテレビ放送局14aに送信され放送される。広告表示は、全画面表示のうちデジタルテレビ画像とは別個の部分、例えば全画面表示の下4分の1の部分に有ることが好ましい。

【0049】レイアウト生成装置28は有効なデータに含まれている文字記述と選択されたクリップアートとから広告表示を作成する。有効なデータの一部を構成するフェードイン、フェードアウト、前景色、背景色、フォント、スクロール、スクロール速度などを利用者が選択できるように、表示の選択肢を設けることも考えられる。レイアウト生成装置28は、この表示の選択肢を利用して広告表示を作成することになる。なお、広告表示は必ずしも静止表示である必要はなく、レイアウト生成装置28はデジタルテレビ画像の各フレームに対して広告表示を作成してもよい。

【0050】本発明の他の実施の形態として、レイアウト生成装置28は第2コンピュータ14に組み込まれていてもよい。それにより、デジタルテレビ画像を処理する際に特に有利になる。

【0051】本発明が上記の実施形態に限定されるものでないことは理解されるべきである。

【図面の簡単な説明】

【図1】本発明の一実施の形態に係る電子広告掲載放送システムを示す概略図である。

【符号の説明】

- 10 広告掲載放送システム
- 12 第1コンピュータ（データサーバ）

- * 14, 16, 18 第2コンピュータ（処理手段）
- 14a, 16a, 18a デジタルテレビ放送システム（メディア放送システム）
- 14b, 16b, 18b デジタルテレビ画像（メディア表示）
- 20 ネットワーク接続コンピュータ
- 22 ネットワーク
- 24 第1記憶装置
- 26 第2記憶装置
- 10 28, 30, 32 レイアウト生成装置（レイアウト生成手段）

*

【図1】

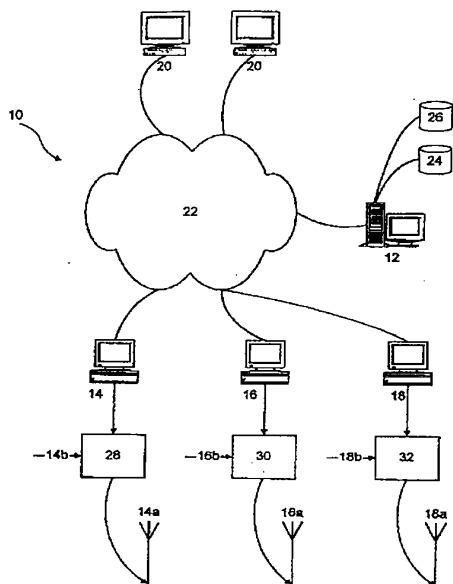

フロントページの続き

(51)Int.Cl.⁷

識別記号

F I

テーマコード（参考）

(71)出願人 599090741
 510 Thomson Road #12-
 04, SLF Building, Sing
 a p o r e 298135

(72)発明者 ロバート ジェフリーズ チャットフィー
 ルド
 シンガポール共和国 319771, トア ベイ
 オー ナンバー04-07 ロロン3 913,
 オリアンダー タワーズ ブロック2

Ref #1

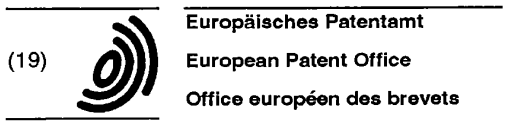

(12) **EUROPEAN PATENT APPLICATION**

(43) Date of publication: **30.08.2000 Bulletin 2000/35** (51) Int Cl.7: **H04H 7/00**

(21) Application number: **99308057.1**

(22) Date of filing: **13.10.1999**

(84) Designated Contracting States:
AT BE CH CY DE DK ES FI FR GB GR IE IT LI LU
MC NL PT SE
 Designated Extension States:
AL LT LV MK RO SI

(30) Priority: **15.02.1999 SG 9900051**

(71) Applicant: **Advent Television Ltd.**
Singapore 298135 (SG)

(72) Inventor: **Chatfield, Robert Jeffries**
357853 Singapore (SG)

(74) Representative: **Powell, Timothy John**
Eric Potter Clarkson,
Park View House,
58 The Ropewalk
Nottingham NG1 5DD (GB)

(54) **A system for electronic placement and broadcast of an advertisement**

(57) A system for placing advertisements and broadcast thereof is disclosed, comprising:

a data server, accessible via a plurality of networked computers, for receiving data concerning an advertisement and arranged to validate said data and communicate validated data to at least one processor means;

each processor means being associated with a corresponding media broadcast system and arranged to allocate each advertisement represented by validated data at least one broadcast time and communicate said validated data to layout generation means at each broadcast time;

said layout generation means responsive to the validated data to produce an advertisement display and to combine the advertisement display with a media display for broadcast by the media broadcast system.

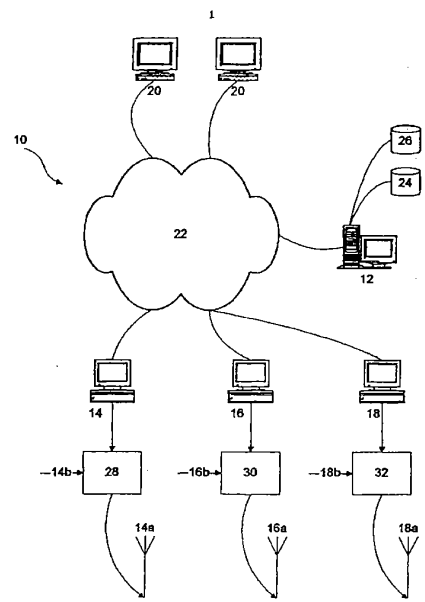

FIGURE 1

EP 1 032 148 A2

DescriptionFIELD OF THE INVENTION

[0001] This invention relates to a system for electronic placement and broadcast of an advertisement. The invention is particularly, although not exclusively, suited for broadcasting advertisements by television.

BACKGROUND ART

[0002] Currently, advertisements can be placed in a number of different media types, including newspapers and television.

[0003] The cost of placing an advertisement in a newspaper is relatively low. However, newspaper classifieds tend to be visually unattractive, typically consisting of large volumes of text. Adding graphic material to a newspaper classified advertisement can significantly increase the cost of the advertisement.

[0004] Television advertisements have a relatively high cost for both production and broadcast. As such, television advertisements are generally not suited to smaller, individual advertisements.

[0005] Television advertisements have the advantage of reaching a group of people who may be watching a single television. Further, television advertisements tend to be more dynamic than printed text and are therefore more likely to catch the attention of a casual observer.

DISCLOSURE OF THE INVENTION

[0006] Throughout the specification, unless the context requires otherwise, the word "comprise" or variations such as "comprises" or "comprising", will be understood to imply the inclusion of a stated integer or group of integers but not the exclusion of any other integer or group of integers.

[0007] In accordance with a first aspect of this invention, there is provided a system for placing advertisements and broadcast thereof, comprising:

a data server, accessible via a plurality of networked computers, for receiving data concerning an advertisement and arranged to validate said data and communicate validated data to at least one processor means;

each processor means being associated with a corresponding media broadcast system and arranged to allocate each advertisement represented by validated data at least one broadcast time and communicate said validated data to layout generation means at each broadcast time;

said layout generation means responsive to the validated data to produce an advertisement display

and to combine the advertisement display with a media display for broadcast by the media broadcast system.

5 **[0008]** Preferably, the data server includes a clip art gallery from which advertisers can select clip art.

[0009] Preferably, said data includes:

10 a text description;
payment information;
selected clip art;
coverage data; and
advertising frequency data.

15 **[0010]** Preferably, said data server includes filter means arranged to remove predetermined words from said text description.

[0011] Preferably, said filter means performs a search of the text description for any word or phrase in a list of prohibited words and phrases.

20 **[0012]** In one arrangement, said filter means is arranged to reject said advertisement if the text description contains more than a predetermined number of prohibited words or phrases.

25 **[0013]** Preferably, said data server includes financial verification means arranged to confirm said payment information is valid.

[0014] Preferably, said financial verification means calculates the cost of said advertisement from at least said coverage data and said advertising frequency data.

30 **[0015]** Preferably, said financial verification means obtains payment for the calculated cost before verifying said data.

[0016] Preferably, said data server is arranged to communicate said validated data to at least one processor means whose media broadcast system operates in said coverage area.

35 **[0017]** Preferably, said data server includes a store of advertisements accessible via the plurality of networked computers.

[0018] Preferably, said data server is arranged to add an advertisement corresponding to validated data to said store.

[0019] Preferably, said media broadcast system comprises a television broadcast station.

[0020] Preferably, said television broadcast station comprises a digital television broadcast station.

[0021] Preferably, said media display comprises a television picture.

50 **[0022]** Preferably, said media display and the advertisement display occupy separate regions on the television.

[0023] Alternatively, the advertisement display is superimposed on the media display.

55 BRIEF DESCRIPTION OF THE DRAWINGS

[0024] The invention will now be described with refer-

ence to one embodiment thereof and the accompanying drawing, which shows the system of the embodiment.

BEST MODE(S) FOR CARRYING OUT THE INVENTION

[0025] The embodiment is directed towards a system 10 for placing advertisements and broadcast thereof. The system 10 comprises a data server in the form of a first computer 12, and three processor means in the form of second computers 14, 16 and 18. Each of the second computers 14, 16 and 18 are associated with a corresponding digital television broadcast system 14a, 16a and 18a.

[0026] The first computer 12 is accessible via plurality of networked computers 20. The first computer 12 and the computers 20 are internetworked by any suitable means, such as a MAN, WAN, or the Internet. The network is shown in the diagram as 22.

[0027] The first computer 12 includes an advertisement placement facility accessible from any of the computers 20. It is envisaged that the advertisement placement facility will be a web page on the Internet in some embodiments.

[0028] A user accessing the advertisement placement facility on the first computer 12 can enter data concerning their advertisement. By submitting their data, the user is requesting that the advertisement is broadcast. This data includes:

- a text description. This forms the basis of the advertisement.
- payment information in the form of a credit card number, expiry date and type.
- clip art selected by the user. The first computer 12 includes a first store 24 of clip art from which the user can choose.
- coverage data selected from a list. The list details the areas that the advertisement can be broadcast to, determined by the coverage area of the digital television broadcast systems 14a, 16a and 18a. The user selects one or more areas from the list according to his or her requirements.
- advertising frequency data, including dates. This data is entered by the user. It is preferred that the advertising frequency data other than the dates are chosen from a list. In this manner, predetermined costs can be ascribed to each item in the list. Examples include the advertisement being broadcast at least four times each day for \$15 per area, or broadcast once per hour for \$40 per area. It is envisaged that a variety of ways of presenting the information to the user can be adopted. It is also envisaged that the user may be able to specify time

slots during which their advertisement will be broadcast.

- email address. This is not essential, however it allows the system 10 to provide the user with feedback concerning their advertisement.

[0029] The first computer 12 then validates the data as follows. Firstly, the text description is passed through a filter to remove any prohibited words or phrases. This is to ensure that undesirable material is not broadcast. The filter can take several forms, including a literal comparison of each word in the text description with a list of prohibited words and a phonetic comparison.

[0030] If the text description contains more than a predetermined number of prohibited words, the advertisement is rejected. If the user supplied an email address, the user is sent a message informing them of the rejection.

[0031] If the message is not rejected, the first computer 12 then calculates the cost of the advertisement from the submitted data. The cost can be based data such as the coverage area, advertisement frequency data, and whether any clip are is selected.

[0032] The first computer 12 then validates the payment information. Preferably, this is done by the first computer 12 effecting payment of the calculated cost from the credit card. If the payment is refused, the advertisement is rejected and the user is sent an appropriate message.

[0033] If the text description and the payment information are successfully validated, the first computer forms validated data comprising the filtered text description, clip art selected by the user, coverage data, advertising frequency data, and email address. The validated data is then communicated to the relevant second computer 14, 16 and/or 18 based on the coverage data. For convenience, the second computers 14, 16 and 18 are also connected to the network 22. In other embodiments, the second computers 14, 16 and 18 may be in communication with the first computer 12 by other means.

[0034] The first computer 12 also includes a second store 26 which contains advertisements that are successfully validated. The advertisements in the second store 26 are accessible from the computers 20 via the Internet 22. Preferably, a search facility is provided for users to access the second store 26.

[0035] Each of the second computers 14, 16 and 18 receives validated data from the first computer 12 for advertisements whose coverage data corresponds with the coverage area of the corresponding digital television broadcast systems 14a, 16a and 18a.

[0036] Each of the second computers 14, 16 and 18 processes the received validated data in the same manner. The following description will be made with reference to the second computer 14, however it is also applicable to the second computers 16 and 18.

[0037] When the second computer 14 receives validated data from the first computer 12, the validated data is processed as follows.

[0038] The second computer 14 analyses the advertisement frequency data to determine the number of times the advertisement will be broadcast, the dates of the broadcast, etc. The second computer 14 then reads the advertisement frequency data of all other validated data it has received concerning the dates and times the current validated data.

[0039] The second computer 14 then schedules the advertisements and allocates particular broadcast times to each advertisement. These broadcast times are stored along with the validated data for each advertisement on the second computer 14. If the second computer 14 determines that a particular time interval is full, it communicates with the first computer 12, which then prevents further users from selecting a full time interval.

[0040] When the broadcast time of an advertisement is reached, the second computer 14 communicates the validated data to a layout generation device 28. If an email address was specified by the user, the second computer 14 sends the user a message confirming when the advertisement was broadcast. The second computers 16 and 18 communicate with layout generation devices 30 and 32, respectively.

[0041] The layout generation device 28 receives validated data from the second computer 14 and a digital TV picture for transmission by the digital television broadcast station 14a, shown in the diagram at 14b. Similarly, digital TV pictures for transmission by the digital television broadcast stations 16a and 18a are shown in the diagram at 16b and 18b, respectively.

[0042] The layout generation device 28 generates an advertisement display from the validated data. The advertisement display is then combined with the digital TV picture 14b. The combined display is sent to the digital TV broadcast station 14a to be broadcast. Preferably, the advertisement display occupies a separate portion of the total display to the digital TV picture, for instance the lower ¼ of the total display.

[0043] The layout generation device 28 creates the advertisement display from the text description and the selected clip art in the validated data. It is envisaged that display options could be provided, whereby the user can select a fade-in and fade-out, foreground and background colours, fonts, scrolling and scrolling speed, etc which would form part of the validated data. The layout generation device 28 would then generate the advertisement display using the display options. Note that the advertisement display is not necessarily a static display, hence the layout generation device 28 generates an advertisement display for each frame of digital TV picture.

[0044] It is envisaged that in some embodiments, the layout generation device 28 may be integrated with the second computer 14. This is particularly advantageous when dealing with digital TV pictures.

[0045] It should be appreciated that the invention is

not limited to the particular embodiment described above.

5 Claims

1. A system for placing advertisements and broadcast thereof, comprising:

10 a data server, accessible via a plurality of networked computers, for receiving data concerning an advertisement and arranged to validate said data and communicate validated data to at least one processor means;

15 each processor means being associated with a corresponding media broadcast system and arranged to allocate each advertisement represented by validated data at least one broadcast time and communicate said validated data to layout generation means at each broadcast time;

25 said layout generation means responsive to the validated data to produce an advertisement display and to combine the advertisement display with a media display for broadcast by the media broadcast system.

30 2. The system of claim 1, wherein the data server includes a clip art gallery from which advertisers can select clip art.

35 3. The system of claim 1 or 2, wherein said data includes:

40 a text description;
payment information;
selected clip art;
coverage data; and
advertising frequency data.

45 4. The system of any one of the preceding claims, wherein said data server includes filter means arranged to remove predetermined words from said text description.

50 5. The system of claim 4, wherein said filter means performs a search of the text description for any word or phrase in a list of prohibited words and phrases.

55 6. The system of claim 5, wherein said filter means is arranged to reject said advertisement if the text description contains more than a predetermined number of prohibited words or phrases.

7. The system of any one of the preceding claims,

- wherein said data server includes financial verification means arranged to confirm said payment information is valid.
8. The system of claim 7, wherein said financial verification means calculates the cost of said advertisement from at least said coverage data and said advertising frequency data. 5
9. The system of claim 8, wherein said financial verification means obtains payment for the calculated cost before verifying said data. 10
10. The system of any one of the preceding claims, wherein said data server is arranged to communicate said validated data to at least one processor means whose media broadcast system operates in said coverage area. 15
11. The system of any one of the preceding claims, wherein said data server includes a store of advertisements accessible via the plurality of networked computers. 20
12. The system of claim 11, wherein said data server is arranged to add an advertisement corresponding to validated data to said store. 25
13. The system of any one of the preceding claims, wherein said media broadcast system comprises a television broadcast station. 30
14. The system of claim 13, wherein said television broadcast station comprises a digital television broadcast station. 35
15. The system of Claim 13 or 14, wherein said media display comprises a television picture.
16. The system of Claim 15, wherein said media display and the advertisement display occupy separate regions on the television. 40
17. The system of Claim 15, wherein the advertisement display is superimposed on the media display. 45
18. A method for placing advertisements and broadcasts thereof, the method comprising:
- receiving, at a data server accessible via a plurality of networked computers, data concerning an advertisement; 50
 validating said data;
 communicating validated data to at least one processor means, each processor means being associated with a corresponding media broadcast system; 55
 allocating to each advertisement, represented
- by validated data, at least one broadcast time; communicating said validated data to layout generation means at each broadcast time; said layout generation means producing an advertisement display responsive to the validated data and combining the advertisement display with a media display for broadcast by the media broadcast system.
19. A computer program product directly loadable into the internal memory of a digital computer, comprising software code portions for performing the method of Claim 18 when said product is run on a computer.
20. Electronic distribution of a computer program according to Claim 19.

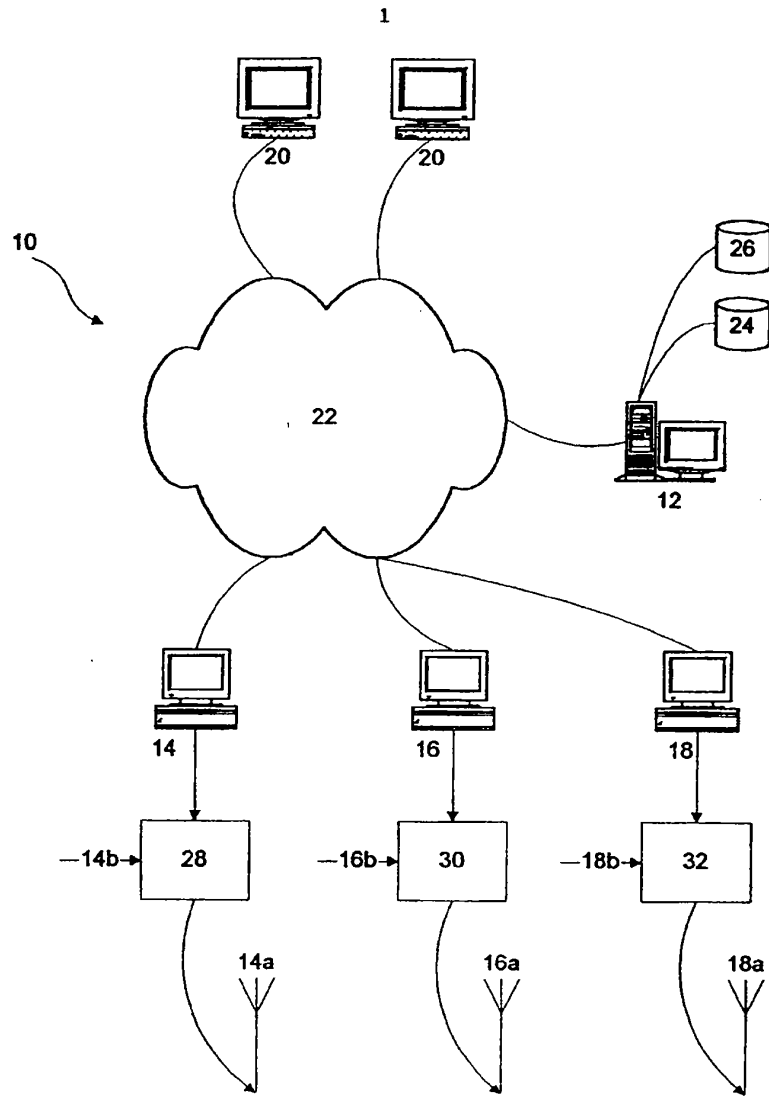

FIGURE 1

PATENT ABSTRACTS OF JAPAN

(11)Publication number : 10-336127
(43)Date of publication of application : 18.12.1998

(51)Int.Cl. H04H 1/00 H04B 7/26

(21)Application number : 09-151696 (71)Applicant : NIPPON TELEGR & TELEPH CORP
<NTT>
(22)Date of filing : 27.05.1997 (72)Inventor : TSUKADA SEIJI
FUKUNAGA HIRONOBU
HAYAKAWA KAZUHIRO
KUMAGAI YOSHIKO
SUZUKI TATSURO

(54) METHOD FOR CIRCULATING INFORMATION AND ITS DEVICE

(57)Abstract:

PROBLEM TO BE SOLVED: To effectively utilize the frame of information circulating media by adding communicating conditions such as an object person, a means, a time and charge burden, etc., to information desired to be circulated so as to input it and circulating information based on the designated circulating condition.

SOLUTION: A receiving device 110 as a communicating means for exchanging the various kinds of digital data of subscribed telephone, ISDN and an internet, etc., receives circulating information from an information originator and stores it in a circulating information database 120. A selecting device 130 selects information communicating media based on the circulating condition which is designated by the information originator and an editing device 140 executes editing in order to

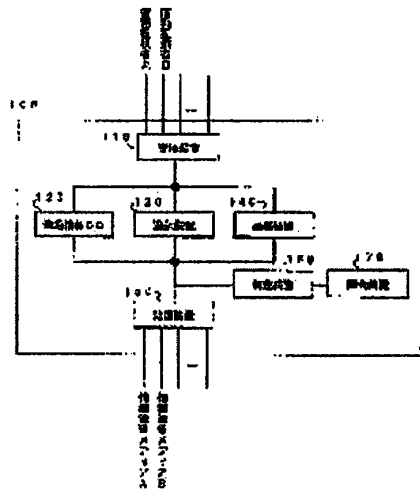

collect the plural pieces of circulating information which can be originated at a time based on the circulating condition. Then, an originating device 150 capable of utilizing communication media such as an electric bulletin board, broadcasting media such as an FM broadcasting and CATV or communication media such as a pager and a telephone, etc., transmits the plural pieces of information to the user. Besides, a charging device 170 manages charge on an information circulation at every information originator.

Partial Translation of Reference 2

Jpn. Pat. Appln. KOKAI Publication No. 10-336127

Filing No.: 09-151696

Filing Date: May 27, 1997

Applicant: NIPPON TELEGR & TELEPH CORP <NTT>

Priority: Not Claimed

KOKAI Date: December 18, 1998

Request for Examination: Not filed

Int.Cl.: H04H 1/00

H04B 7/26

[A]

Column 2, Line 43 to Column 3, Line 14

[0008]

[Embodiments]

[Example of Basic System Configuration]

FIG. 1 is a system configuration diagram of an information distribution device according to an example of the present invention. FIG. 1 shows an information distribution device 100 of the present example. The information distribution device 100 can be fabricated by using a computer system including a combination of sections 110, 120, 130, 140, 150, 160, and 170 described below. The section 110 is a receiving means for receiving distribution information from an information sender. The receiving means 110 is achieved by a communicating means that can exchange variety of digital data, represented by a subscribed telephone, an ISDN, and the Internet. The section 120 is a distribution information DB that stores distribution information received from an information sender. The section 130 is a selection device that selects information distribution media based on a distribution condition designated by an information sender. The section 140 is an editing device for organizing a plurality of pieces of distribution information that can be transmitted at once based on the distribution condition. The section 150 is a transmission device that sends information to users. For the transmission device 150, an electronic bulletin board, broadcasting media, such as FM broadcast and CATV, or communication media, such as a pager and a telephone, is used. The section 160 is a determination device that determines whether or not a result of transmission of information by the transmission device 150 satisfies the distribution condition. The section 170 is a charging device that manages values of information distribution for each information sender.

[B]

Column 3, Line 25 to Column 4, Line 8

[0012] FIG. 5 is an example of the flow of processing of the information distribution device 100. First, whether or not there is data from an information sender is checked (501). If there is, the receiving device 110 receives the data, and the information distribution DB 120 stores the data (503). Next, whether or not there is any information that has not been sent in the information distribution DB 120 is checked (505). If there is, whether or not information distribution media is designated is

checked (507). If information distribution media is designated, whether or not there is any other information that can be edited and transmitted together is checked (513). If there is, the editing means 140 edits the information (517). When no information distribution media is designated, the selection device 130 selects whether or not there is any information distribution media that satisfies a distribution condition (509). If there is information distribution media that satisfies the condition, processing that is the same as that carried out when information distribution media is designated is carried out. If information distribution media cannot be selected, whether or not there is any other information that can be transmitted together by editing is checked (511). If there is, whether or not the distribution condition is satisfied by editing is checked (515). If the condition is satisfied, processing that is the same as that carried out when information distribution media is designated is carried out. Next, whether or not a time for sending information is reached is checked (519). If the time is reached, the transmission device 150 transmits information to the selected information distribution media (523). The determination device 160 determines whether or not the information has been transmitted in accordance with the condition. Then, the charging device 170 updates charging information of the information sender (525). In addition, if the time for information transmission has not been reached yet, information distribution media is designated and the information is stored in the distribution information DB 120 (521). Also, when information distribution media that satisfies the distribution condition cannot be selected, and there is no distribution information put together by editing, or the distribution condition cannot be satisfied even by editing, whether a time for sending information has been reached or not is checked (527). When the time for sending information has been reached, the information sender is notified of the fact that transmission of the information is not possible (529). If the time for information transmission has not been reached yet, information is stored in the distribution information DB 120 without designating information distribution media (533).

[C]

Column 6, Line 26 to Line 34

[Explanation of Reference Symbols]

100: Information distribution device

110: Receiving device

120: Distribution information database

130: Selection device

140: Editing device

150: Transmission device

160: Determination device

170: Charging device

(1) Information provider A

(2) Information provider B

(3) Information distribution media A

(4) Information distribution media B

[FIG. 1] System Structure Figure

110: Receiving device

120: Distribution information database

130: Selection device

- 140: Editing device
- 150: Transmission device
- 160: Determination device
- 170: Charging device
- (1) Information provider A
- (2) Information provider B
- (3) Information distribution media A
- (4) Information distribution media B

整理番号: 発送番号:441719 発送日:平成21年 7月 7日 1

Ref 3

引用非特許文献

特許出願の番号	特願2006-553357
作成日	平成21年 7月 1日
作成者	川口 貴裕 3055 5J00
発明の名称	公共サービスメッセージの放送システム及び方法

本複製物は、特許庁が著作権法第42条第2項第1号の規定により複製したものです。
取扱いにあたっては、著作権侵害とならないよう十分にご注意ください。

情報処理学会第59回(平成11年後期)全国大会

特1-261

家庭向け公共情報配信システムの提案

4D-6

THAPANANGKUN PONGTHORN¹⁾
立命館大学理工学研究科¹⁾

遠藤 裕英¹⁾
立命館大学理工学部¹⁾

1. はじめに

従来、自治体の広報は広報誌など紙媒体を中心に行われてきた。しかし、この方法では、伝達時間と広報経費がかかるという問題点とともに伝達の確実性という面でも問題があった。解決方法の一つとして、WWW(World Wide Web)の普及とともに自治体情報の広報にもWWWが使われるようになった。この方法を利用すれば伝達時間を短くでき、経費も安く済ませられる。しかし、平成10年度におけるパソコンの世帯保有率が82.6%、インターネットの世帯普及率が11%という現状¹⁾では、広報手段としてWWWに全面的に依存するには問題がある。また、操作の簡単さという点でも、現状の操作性では一般家庭への普及には限界があると考えられる。

一方、TVの世帯保有率は95%を超え、2000年になると地上波のデジタル放送が予定されている現状から、デジタル放送を利用した自治体情報の広報が考えられる。

そこで、デジタル放送を利用した、迅速で安価、操作が容易、各家庭にカスタマイズされた情報の受信、という特徴をもつ、家庭向け公共情報配信システムを提案する。

2. 自治体情報の広報の現状と問題点

ある自治体では広報誌を毎月1日と15日に発行し、市内の各町内会を通じて住民に配布している。発行される広報誌はA4サイズで、1日発行分が20枚程度と15日発行分が10枚程度である。しかし、現状の問題点として、次のようなものがある。

1. 各町内会に入っていない市民に広報誌が配られていない。
2. 大量の広報誌を作成するのに膨大な経費がかかる。
3. 未配布用に市役所に置いてある広報誌を取りに来る市民が少ない。

また、広報誌以外にも自治体のWWWホームページで広報する方法も進めている。

WWWを使用して広報を配信する問題点として、1ヶ月分の広報量はA4サイズ30枚程度にのぼるが、これらのフル情報をも市民がフォローするのは考えにくい。その上、インターネットを使用できる環境でなければ広報を見ることができない。

そこで、今年から有線放送が本格的にはじまることもあって、何らかの形でデジタル放送を使用して広報を市民にプッシュ型で配信することができないかを現在検討中である。

3. システム概要

本研究の家庭向け情報配信サービスシステムのイメージを図1に、情報配信タイムスケジュールを図2に示す。

地方自治体から発信される情報はテキスト情報が多いため、一つの情報のサイズは小さい。情報を入力するたびにインターネットを通してプロバイダに送信するには効率が悪いので、まず発信したい情報を図3に示す情報入力画面で行い、WEBサーバに情報をHTML形式で蓄積する。送信者がそれぞれの情報に図3に示すように受信者を特定する情報を添付する。こうすることによって、簡単に特定の受信者向けに情報を発信することができる。

次に、図4に示すようにたくわえている情報を設定した時間に一括してプロバイダに送信する。

A Proposal of Customized Information Receiver for Local Government Publication
Pongthorn Thapanangkun, Hirohide Endo
Ritsumeikan University
1-1-1, Noji-higashi, Kusatsu, Japan

本複製物は、特許庁が著作権法第42条第2項第1号の規定により複製したものです。取扱いにあたっては、著作権侵害とならないよう十分ご注意ください。

特1-252



図1 全体システム図



図2 情報配信タイムスケジュール

これは、インターネットを常時接続していない地方自治体にとっては効率的な方法といえる。プロバイダは地方自治体から受信した情報をHTML形式で放送局に送信する。放送局からデジタル放送で家庭に向けて送信される。デジタル放送の利点として一回の送信操作で大量のデータを配信することができるから、

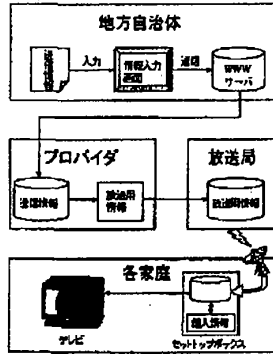
情報を分割して送信しなくて済むし、時間の無駄が少なくなる。ここでは放送局がプロバイダから受信したHTML形式の公共情報をそのまま放送波を利用して、決まった時間に各家庭に向けて発信することだけの役割になる。ここでプッシュ型システムを使用すれば、決まった時間に一日一回だけ大量の情報を発信する。しかし、情報量が多くなると、受信者側にとりだだけ受信者のニーズに合った情報選択機能を持たせられるかが課題になる。

4. 情報発信側の処理

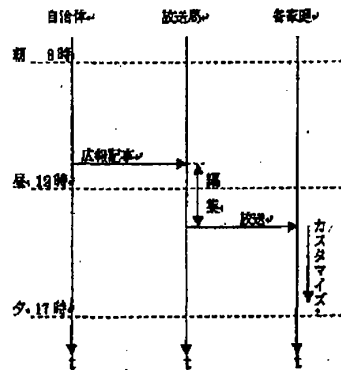
図3に家庭向け情報配信システムの情報発信側画面例を示す。

情報の分類項目として以下のような項目がある。

- ・名前
特定の人に情報を送るときにその人の名前を指定して送ることができる。
- ・年齢
年齢制限のある情報を送信するときに、年齢を指定し送信できる。
- ・性別
- ・居住区域
その区域に住んでいる家庭向けの情報を送信できる。
- ・年取
特定の年取区分の人に情報を送信できる。
- ・職業
職業別の情報や専門分野別の情報を送信するのに役に立つ。
- ・年金受給
いろいろな年金対象の情報を確実に年金受給者に送信できる。

この画面で送信者が送信したい情報と一緒に、受信対象者の分類項目を特定することによって、特定の受信者向にその情報を送信することができる。そして、情報内容を入力した後に自治体のWWWサーバに用意した情報送信フォームに情報をたくわえておく。

本複製物は、特許庁が著作権法第42条第2項第1号の規定により複製したものです。取扱にあたっては、著作権侵害とならないよう十分にご注意ください。



図3 情報送信画面

また、本システムでは受信者の情報受信端末としてテレビを使用するため、送信側から送信されてくる広報の中には図表が含まれることが考えられるので、そういった図表をどのようにテレビ画面上に表示させるかを検討する必要がある。

5. 情報受信側の処理

本システムにおいて、最も重要な役割を果たすのは情報受信側の情報選択機能である。放送波を用いてデジタル放送で送られてくる情報は大量であるから、受信者の登録情報に応じて情報を選択する機能が必要になる。情報選択機能の仕組みを図4に示す。

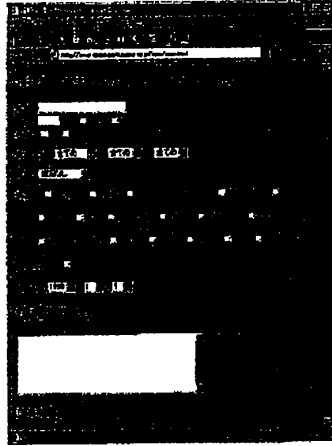
放送波を用いて一日一回の割合で情報を配信するとして、送信されてきた情報をまず各家庭の情報受信用セットトップボックスにいったん全てのデータを蓄積しておく。蓄積された情報をあらかじめ登録しておいた受信者の個人情報とデータを照合して必要な情報だけを残し、不必要なものを削除する仕組みとする。



図4 情報選択機能の仕組み

情報受信者の居住区域・家族構成の設定と個人情報の設定については受信者各自が各家庭の情報受信用セットトップボックスのメインメニュー画面・個人情報設定画面で個人情報を設定することができ、設定項目は次のようになる。また、メインメニュー画面・個人情報設定画面のイメージを図5と図6に示す。

- ・居住区域
家族の居住区域は共通情報であるため、共通画面で設定を行う。
- ・家族構成
家族の居住区域と同様、共通情報であるため、共通画面で設定する。
- ・名前
受信者のそれぞれの名前を記入する。
- ・世帯主
チェックボックスになっていて、家族全員に送信されてきた情報は全員の受信画面ではなく、「世帯主」の画面だけに表示される。
- ・年齢、性別、年取
送信された情報と一緒に年齢・性別・年取の指定があれば、それぞれ該当する受信者の画面に情報を表示させる。
- ・年金受給
遺族厚生年金・障害厚生年金・老齢厚生年金などを受給している人に関する情報を選択できるようにチェックする。

本複製物は、特許庁が著作権法第42条第2項第1号の規定により複製したものです。取扱いにあたっては、著作権侵害とならないよう十分にご注意ください。

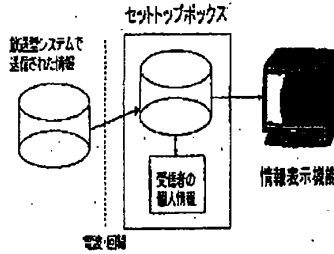
特1-264

・職業

受信者の職業を設定し、職業ごとに送信してきた情報を選択する。

この受信者側（家庭側）設定項目は送信側（地方自治体側）から配信された情報に含まれる情報の分類項目と照合して、該当する情報だけを個人のところに表示させるようになっている。また、分類されていない情報については全ての受信者宛に送信されるため、各家庭の世帯主のところに表示させる。



図5 メインメニュー画面

図6 個人情報設定画面

また、本システムでは配信されてきた情報を受信者に表示する端末として、テレビを使用する。従って、テレビ画面を情報受信者にとって見やすく表示されることが必要になる。セットトップボックスで選択された情報を個人のそれぞれの画面に表示させる。表示モードは受信者の好みにより

設定でき、表示モードは以下の3つに設定できる。

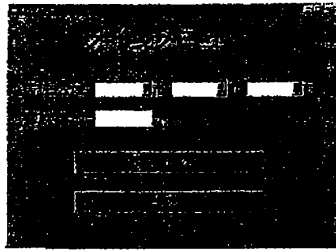
・手動表示型

情報受信者によって表示のタイミングを設定することができる。例えば、決まった時間に毎日表示するように設定することができる。この表示強度を「弱」とする。

・自動表示型

テレビをつけた瞬間に受信された情報をセットトップボックスで表示する。この表示強度を「中」とする。

・常駐表示型

常時にテレビをつけておき、情報を受信すると同時に、テレビの画面上受信された情報の内容を表示させる。ただし、この方法では緊急な情報の受信以外はあまり向かない。この表示強度を「強」とする。

以上を表1にまとめる。

表1 情報の表示タイミング

	表示タイミング	表示強度
手動表示型	情報受信によって表示方法を設定してもらうことにより、情報を画面上に表示する	弱
自動表示型	受信された情報をセットトップボックスで表示の準備をし、テレビをつけたときに表示させる	中
常駐表示型	情報を受信すると同時に画面上に表示する	強

6. システムの評価

本稿で提案した家庭向け情報配信システムを評価するために、表2の家族構成モデルを対象にある自治体のホームページ⁹⁾で実際に開示された連絡情報を使用し、6の情報分類項目に従って分類した結果を表3に示す。

表3で示すように、情報No. 1, No. 3では情報の分類内容が指定されていないため、世帯主の

本複製物は、特許庁が著作権法第42条第2項第1号の規定により複製したものです。取扱いにあたっては、著作権侵害とならないよう十分にご注意ください。

情報処理学会第59回(平成11年後期)全国大会

特1-265

個人画面に表示される。情報 No. 2, No. 4, No. 9 では年齢にそれぞれ 18~30, 18~25, 15~22, また No. 9 の職業に高校・大学生と指定されているから、これらの情報は長男である佐藤純一の個人画面に表示される。情報 No. 5 は 40 歳~60 歳に指定されているため、この条件に該当する人物は父・母の二人であるが、世帯主である父を優先させるようにしているから、父の佐藤健太の個人画面に表示されることになる。また、情報 No. 6~No.8 は年齢のところにそれぞれ 6~14, 12~14, 9~14 で、職業の欄ではどれも小・中学生になっているから、長女の佐藤晶子の個人画面に表示される。最後に、情報 No. 10 の年金受給の有無で「有り」になっているということは、家族でただ一人年金を受給している祖父の佐藤義則の個人情報画面に情報が表示されることになる。

また、個人情報で自治体からの広報を分別する方法以外に本研究では情報を種類別に分類することを検討している。分類項目として以下のような項目がある。

1. 募集 (人・住宅)
2. 生活 (安全・健康・環境・国際交流・労働)
3. 福祉 (障害者・児童母子・高齢者・社会保険)
4. 教育・文化 (学校教育・社会教育・文化・スポーツ)
5. 行政 (税金・広報・都市計画)
6. 産業・工業
7. イベント・施設

上記の情報分類項目で実際の 147 件の広報を分類した結果を表 4 で示す。

7. おわりに

本稿では地方自治体からの公共情報などを電波やデジタル放送などのメディアを通じて各家庭に配信される状況を想定し、受信者側の各家庭にセットトップボックスを装備されると仮定し、各セットトップボックスで地方自治体から配信されてきた情報を居住区域、家族構成、年齢、年収、職業、年金受給などの個人情報に基づき、該当する情報を選択的に抽出し、テレビに表示するシステムを提案した。今後の課題としては、選択された情報をテレビ画面で実際に表示し、個々の受信者に対して最適化できるように拡張する予定である。また、本システムで使用する HTML コンテンツ技術言語は基本的に情報提供者が記述した内容をユーザ毎に異なった情報を提供するパーソナライズサービスを行う上での情報記述フォーマットとしては十分でない。新しいタグや属性名を意のままに定義することができる HTML に代わる次世代の文書記述言語 XML(extensible Markup Language)の標準化が進められているので、本システムの XML の使用について検討していきたい。

参考文献

- 1) 神崎:パーソナライゼーション技術, 1999 年情報学会シンポジウム講演論文集, pp.32-40 (1999)
- 2) 神崎, 坂上, 古閑:ブッシュ型とフル型を統合したパーソナライズ情報配信システムの提案と実装, 情報処理学会論文誌, Vol.39, No.5, pp.1514-1522 (1998)
- 3) 藤保, 竹内:PUSH 型情報提供システムの構成法, マルチメディア通信と分散処理, No.38, pp.1-6 (1998)
- 4) 高橋, 佐藤, 鈴木, 曾根岡:パーソナライズ情報提供方式の提案と評価, 情報処理学会論文誌, Vol.40, No.1, pp.175-187 (1999)
- 5) 滋賀県ホームページ: <http://www.pref.shiga.jp/>
- 6) 郵政省編:平成 11 年版通信白書, ぎょうせい (1999)

表 2 家族構成モデル

	名前	年齢	性別	居住区域	年収(万円)	職業	年金受給
祖父	佐藤 義則	70	男	彦根市	0	退職者	有り
父(世帯主)	佐藤 健太	52	男		2000	企業経営	
母	佐藤 麻由美	48	女		100	専業主婦	
長男	佐藤 純一	19	男		100	大学生	
長女	佐藤 晶子	13	女		0	中学生	

本複製物は、特許庁が著作権法第42条第2項第1号の規定により複製したものです。
 取扱にあたっては、著作権侵害とならないよう十分にご注意ください。

特1-266

表3 情報の分類結果

情報No	年齢	性別	居住区域	年収	職業	年金受給
1	指定なし	指定なし	指定なし	指定なし	指定なし	指定なし
2	18~30	指定なし	彦根市	指定なし	指定なし	指定なし
3	指定なし	指定なし	指定なし	指定なし	指定なし	指定なし
4	18~25	指定なし	指定なし	指定なし	指定なし	指定なし
5	40~60	指定なし	指定なし	指定なし	指定なし	指定なし
6	6~14	指定なし	指定なし	指定なし	小・中学生	指定なし
7	12~14	指定なし	指定なし	指定なし	小・中学生	指定なし
8	9~14	指定なし	指定なし	指定なし	小・中学生	指定なし
9	15~22	指定なし	指定なし	指定なし	高校・大学生	指定なし
10	指定なし	指定なし	指定なし	指定なし	指定なし	有り

表4 分類別の情報の分類結果

分類項目	件数	割合
募集	29	19.70%
人	23	15.60%
住宅	8	4.00%
生活	23	15.60%
安全	8	4.00%
健康	3	2.00%
環境	8	5.40%
国際交流	4	2.70%
労働	2	1.30%
福祉	13	8.80%
障害者	7	4.70%
児童母子	2	1.30%
高齢者	2	1.30%
社会保険	2	1.30%
教育・文化	29	19.70%
学校教育	3	2.00%
社会教育	0	0.00%
文化	8	5.40%
スポーツ	18	12.20%
行政	36	22.40%
税金	12	8.10%
広報	19	12.90%
都市計画	5	3.40%
産業・工業	6	4.00%
イベント・施設	11	7.40%

本複製物は、特許庁が著作権法第42条第2項第1号の規定により複製したものです。
取扱にあたっては、著作権侵害とならないよう十分にご注意ください。

58

第59回(平成11年後期)全国大会
特別セッション(1)講演論文集

情報家電とホームネットワーク

平成11年9月28日～30日 於:岩手県立大学

 社団法人 情報処理学会

Information Processing Society of Japan

<http://www.ipsj.or.jp>

本複製物は、特許庁が著作権法第42条第2項第1号の規定により複製したものです。
取扱いにあたっては、著作権侵害とならないよう十分にご注意ください。

複写される方に

 <学術著作権協会委託>

本誌に掲載された著作物を複写したい方は、(社)日本複写権センター
と包括複写許諾契約を締結されている企業の従業員以外は、著作権者から
複写権等の行使の委託を受けている次の団体から許諾を受けて下さい。

著作物の転載・翻訳等複写以外の許諾は、直接当学会へご連絡ください。

〒107-0052 東京都港区赤坂 9-6-41 乃木坂ビル3F

学術著作権協会 Tel: (03) 3475-5618 Fax: (03) 3475-5619

E-mail: kammori@msh.biglobe.ne.jp

アメリカ合衆国における複写については、下記に連絡してください。

Copyright Clearance Center, Inc. (CCC)

222 Rosewood Drive, Danvers, MA 01923, USA

Phone: 1-978-750-8400 Fax: 1-978-750-4744

<http://www.copyright.com>

Notice about Photocopying

In order to photocopy any work from this publication, you or your
organization must obtain permission from the following organization,
which has been delegated for copyright for clearance by the copyright
owner of this publication.

Except in the USA:

Japan Academic Association for Copyright Clearance (JAACC)

41-6 Akasaka 9-chome, Minato-ku, Tokyo 107-0052, Japan

Tel: 81-3-3475-5618 Fax: 81-3-3475-5619

E-mail: kammori@msh.biglobe.ne.jp

In the USA

The Copyright Clearance Center, Inc. (CCC)

222 Rosewood Drive, Danvers, MA 01923, USA

Phone: (978) 750-8400 Fax: (978) 750-4744

<http://www.copyright.com>

第59回(平成11年後期)全国大会
特別セッション(1)講演論文集

1999年9月28日 発行

©情報処理学会 1999

発行所 〒108-0023 東京都港区芝浦3-16-20

芝浦前川ビル 7F

社団法人 情報処理学会

Tel. 東京 (03) 5484-3535 (代表)

E-mail: jigyos@ipsj.or.jp

郵便振替口座 (00150-4-83484)

発行人 社団法人 情報処理学会

柳川隆之

Information Processing Society of Japan

本複製物は、特許庁が著作権法第42条第2項第1号の規定により複製したものです。取扱いにあたっては、著作権侵害とならないよう十分にご注意ください。

Here. The Future
HITACHI

FLORA 400 series

CPU
Pentium® II
Xeon™ 450MHz
Pentium® ED707
9D

メインメモリー
128MB/64MB

HDD
9.1GB

グラフィックス
NVIDIA GeForce
AGP/Quadra
Accelerator

**プロのニーズにこたえる
グラフィック性能と処理性能。
CAD、CAM、CGなどの技術系分野で
実力を発揮。**



H12スリーパー-TFT液晶ディスプレイ(売切)との組み合わせです。

FLORA 450をデュアルディスプレイ環境で使うなら、この液晶ディスプレイ用アーム。

広々と仕事ができるから、CAD、CG分野でニーズが異なるデュアルディスプレイ。日立なら、ここまで徹底したサポートが実現可能。

思いのままに作業の効率を高められる。

液晶ディスプレイ用アームには、液晶ディスプレイの傾きを自由に調整できます。プレゼンテーションにも、グループワークにも活用可能。アジャスト機構にも対応しています。

目覚まし機能にさらに便利な機能。

ディスプレイは日立独自のスリーパー-TFT液晶LED。CPUに5分未満のアイドル時は自動的に電源をオフにして、省電力を実現しています。

**Pentium® II Xeon™
プロセッサ(450MHz)搭載。
デュアルディスプレイ対応。**

FLORA 450

◎ **株式会社 日立製作所 東北支社** (取入および取寄の) HCAセンターフリーダイヤル ☎0120-2580-81
〒980-8531 仙台市青葉区一番町二丁目4番1号(東区ビル) ☎(022)223-5240 (送料別) 利用時間/9:00~17:00(土、日、祝日を除く)

第59回(平成11年後期)全国大会 特別セッション(1)講演論文集
Copyright © 1999 by The Information Processing Society of Japan

平成二十一年九月二十八日発行

編集兼発行人 御川 隆之
東京青葉区一番町三十一番一〇〇号青葉川ビル7F

印刷所 三陽印刷株式会社
東京都目黒区目黒五丁目五〇一七

発行所 株式会社 御川 隆之
東京青葉区一番町三十一番一〇〇号(青葉川ビル7F)

本誌文庫に掲載された論文の著作権は、各著者さまに帰属します。

Partial Translation of Reference 3

Non-Pat. Document: Information Processing Society of Japan

Jpn. Pat. Appln. No. 2006-553357

[A]

Page 2, Right Column, Line 18 to Page 3, Right Column, Line 9

3. Outline of System

FIG. 1 shows a schematic diagram of a domestic information distribution service system of this research, and FIG. 2 shows an information distribution time schedule.

Since a large part of information transmitted from local authorities is text information, size of one piece of information is small. It is not efficient to transmit information to a provider through the Internet every time information is input. Therefore, information to be transmitted is first accumulated in a web server in an HTML format after being input on an information input screen shown in FIG. 3. A sender attaches information that identifies a recipient to each piece of information as shown in FIG. 3. In this manner, information can be easily transmitted to a specific recipient.

Next, accumulated information is transmitted to a provider at once at a set time as shown in FIG. 4.

This is considered an effective method for local authorities that are not connected to the Internet all times.

The provider transmits the information received from the local authorities to a broadcasting station in an HTML format.

The broadcasting station transmits the information to homes by digital broadcasting. As an advantage of digital broadcasting, a large amount of data can be distributed by one time of transmission operation. Therefore, the information does not need to be divided for transmission, and less time is wasted. A role here is only that the broadcasting station transmits public information in an HTML format received from the provider as it is to homes at a set time by using a broadcast wave. Here, if a push-type system is used, a large amount of information is transmitted at a set time only once a day. However, when an amount of information is large, there is an issue as to how much an information selecting function that a recipient side has matches with the needs of a recipient.

FIG. 1 Entire system diagram

- (1) Local authorities
- (2) Transmitted information
- (3) Input
- (4) Information input screen
- (5) Communication
- (6) WWW server
- (7) Provider
- (8) Communication information

- (9) Broadcasting information
- (10) Broadcasting station
- (11) Personal information
- (12) Set-top box
- (13) Home
- (14) TV

FIG. 2 Information distribution time schedule

- (1) Local authorities
- (2) Broadcasting station
- (3) Home
- (4) Morning
- (5) 8:00
- (6) Noon
- (7) 12:00
- (8) Publicity article
- (9) Edit
- (10) Broadcast
- (11) Customize
- (12) Evening
- (13) 17:00

[B]

Page 3, Right Column, Line 10 to Page 5, Right Column, Line 28

4. Processing on Information Origination Side

FIG. 3 shows an example of an information transmission side screen of the domestic information distribution system.

There are the following classification items of information:

- Name

Information can be sent to a specific person by designating the name of the person.

- Age

Age-restricted information can be transmitted by designating an age.

- Sex

- Residential area

Information for homes residing in the area can be transmitted.

- Annual income

Information can be transmitted to people in a specific annual income group.

- Occupation

Useful for transmitting information classified by occupations and information classified by specialized fields.

- Pensioner

Information targeted on variety of pensions can be reliably transmitted to pensioners.

On this screen, the sender specifies classification item of a target recipient together with information the sender desires to transmit. In this manner, the information can be transmitted to the specified recipient. Then, after an information content is input, the information is accumulated in an information transmission form

prepared in a WWW server of local authorities.

In addition, since the present system uses a TV as an information receiving terminal of a recipient, publicity transmitted from a transmission side is considered to include a diagram. Therefore, consideration needs to be made as to how such a diagram is displayed on a TV screen.

5. Processing on Information Receiving Side

An information selecting function of an information receiving side plays the most important role in the present system. Since a large amount of information is sent in digital broadcasting by using a broadcast wave, a function for selecting information in accordance with registration information of a recipient is necessary. FIG. 4 shows a mechanism of the information selecting function.

Assuming that information is distributed by using a broadcast wave once a day, all data of the transmitted information is first stored in an information receiving set-top box in a home at once. Data of the accumulated information is collated with personal information of a recipient registered in advance, then necessary information is kept and unnecessary information is erased.

In setting an residential area and a family structure of an information recipient and setting personal information, each recipient can set personal information on a main menu screen and a personal information setting screen of an information receiving set-top box installed in each home. Setting items are as described below. Also, views of the main menu screen and the personal information setting screen are shown in FIGS. 5 and 6.

- Residential area

Since a residential area of a family is common information, setting is made on a common screen.

- Family structure

As similar to a residential area of a family, a family structure is common information and setting is made on a common screen.

- Name

A name of each recipient is entered.

- Head of the household

A check box is provided. Information that is sent to all family members is displayed only on a screen of the "head of the household", not on receiving screens of all the family members.

- Age, sex, annual income

When there is designation of an age, sex, or an annual income together with the transmitted information, the information is displayed on a screen of a corresponding recipient.

- Pensioner

This item is checked so that information relating to a person receiving a survivor's employee's pension, a disability employee's pension, an old-age employee's pension, and the like can be selected.

- Occupation

An occupation of a recipient is set, and transmitted information is selected according to occupations.

The above recipient side (home side) set items are collated with classification items of information included in information distributed from a transmission side (local authorities side), and only corresponding information is displayed on a personal screen. Also, unclassified information is to be transmitted to all recipients, and therefore such information is displayed on a screen of a head of the household.

In addition, a TV is used as a terminal that displays distributed information to a recipient in the present system. Therefore, a TV screen needs to be displayed in a manner that an information recipient can easily view the screen. Information selected by using a set-top box is displayed on a corresponding screen. A display mode can be set in accordance with a preference of a recipient. The display mode can be set to one of the following three modes:

- Manual display type

An information recipient can set a display timing. For example, information can be set to be displayed at a set time every day. This display strength is "weak".

- Automatic display type

Received information is displayed by using a set-top box at the moment when a TV is turned on. This display strength is "intermediate".

- Resident display type

A TV is turned on at all times, and a content of received information is displayed on the screen of the TV at the same time as the information is received. This method is not suitable for cases other than receiving emergency information. This display strength is "strong".

The above is organized in Table 1.

FIG. 3 Information transmission side screen

FIG. 4 Mechanism of information selecting function

(1) Set-top box

(2) Information transmitted in broadcasting type system

(3) Personal information of recipient

(4) Information displaying function

(5) Radio wave, line

FIG. 5 Main menu screen

FIG. 6 Personal information setting screen

Table 1 Timings of displaying information

(1) Display timing

(2) Display strength

(3) Manual display type

(4) A display method is set by information receiving to display the information on a screen.

(5) Weak

(6) Automatic display type

(7) Received information is displayed when a set-top box prepares for display and a TV is turned on.

(8) Intermediate

(9) Resident display type

(10) Information is displayed on a screen at the same time as the information is received.

SUZUYE & SUZUYE 

(11) Strong

PATENT ABSTRACTS OF JAPAN

(11)Publication number : 09-098140

(43)Date of publication of application : 08.04.1997

(51)Int.Cl.

H04H 1/00

(21)Application number : 07-256065

(71)Applicant : FUJITSU LTD

(22)Date of filing : 03.10.1995

(72)Inventor : IWABUCHI YOSHIO

(54) AUTOMATIC BROADCASTING DEVICE

(57)Abstract:

PROBLEM TO BE SOLVED: To attain automatic broadcasting facilitated in the input and editing of broadcasting sentences concerning an automatic broadcasting device for automatic broadcasting at the designated date and hour.

SOLUTION: The broadcasting sentence in a character input format is inputted from an input part 2, the editing of the broadcasting sentence is performed, and the date and hour of broadcasting are designated and stored in a storage device 6. A control processor 5 reads the broadcasting sentence from the storage device 5 at the designated date and hour while referring to a clock 1 provided with a calendar function, the syntax analysis and semantic analysis of this broadcasting sentence are performed by a voice synthesizer provided with a voice data editing part 7, voice data storage part 8 and voice synthesizing output part 9, and the sentence is transformed to a voice signal showing a voice waveform according to the analyzed result and broadcast from radio equipment 11 or the like.

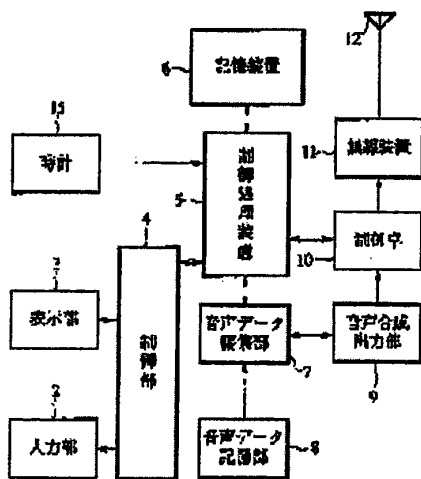

and the sentence is transformed to a voice signal showing a voice waveform according to the analyzed result and broadcast from radio equipment 11 or the like.

Partial Translation of Reference 4

Jpn. Pat. Appln. KOKAI Publication No. 09-098140

Filing No.: 07-256065
Filing Date: October 3, 1995
Applicant: FUJITSU LTD
Priority: Not Claimed
KOKAI Date: April 8, 1997
Request for Examination: Not filed
Int.Cl.: H04H 1/00

[A]

Column 1, Line 21 to Line 23

[Claim 3]

The automatic broadcasting device according to claim 4, wherein the automatic broadcasting card includes sections for date and time of broadcasting, a broadcasting area, a type of broadcasting, and a name and a content of broadcasting.

[B]

Column 1, Line 37 to Line 48

[Detailed Description of the Invention]

[0001]

[Technical Field of the Invention]

The present invention relates to an automatic broadcasting device that automatically broadcasts a broadcasting sentence input in advance. A variety of broadcasting systems, such as a disaster prevention and administrative radio system in local authorities and the like, a cable broadcasting system in a farming community and the like, and an in-house broadcasting system in an office, a factory, and the like, are known. Broadcasting is normally carried out by operation of an announcer or an operator. Also, there is known an automatic broadcasting system that automatically broadcasts content that has been recorded in advance at a specified date and time, such as holidays including Sunday and national holidays, and during nighttime, where there is no announcer or operator.

[C]

Column 6, Line 3 to Line 13

[0026] FIG. 4 is an explanatory view showing important sections of a third example of the present invention. Reference symbols that are the same as those in FIG. 3 indicate the same sections, and a reference symbol 16 indicates a modem. FIG. 4 shows a configuration where an automatic broadcasting device is connected to a telephone line through the modem 16. An automatic broadcasting card created by a terminal device (not shown) is transmitted as a facsimile image or data. The modem 16 functioning as a receiving device receives the facsimile image or data. The control device 14 controls the display section 3 to display the facsimile image or data. The user can check the content and store the facsimile image or data in the storage device 6. In this case, an authentication system for accessing the automatic broadcasting

device through a line can be provided.

[D]

Column 8, Line 4 to Line 15

[Explanation of Reference Symbols]

- 1: Clock
- 2: Input section
- 3: Display section
- 4: Control section
- 5: Control processing device
- 6: Storage device
- 7: Voice data editing section
- 8: Voice data storage section
- 9: Voice synthesis output section
- 10: Control console
- 11: Radio device
- 13: Voice synthesis device
- 14: Control device
- 16: Modem
- 2A: Keyboard

PATENT ABSTRACTS OF JAPAN

(11)Publication number : 2000-165826
 (43)Date of publication of application : 16.06.2000

(51)Int.Cl. H04N 7/08 H04N 7/081
 H04H 1/00 H04N 5/44

(21)Application number : 10-335504 (71)Applicant : NEC HOME ELECTRONICS LTD
 (22)Date of filing : 26.11.1998 (72)Inventor : NAKAJIMA MASAMITSU

(54) DATA BROADCASTING EQUIPMENT

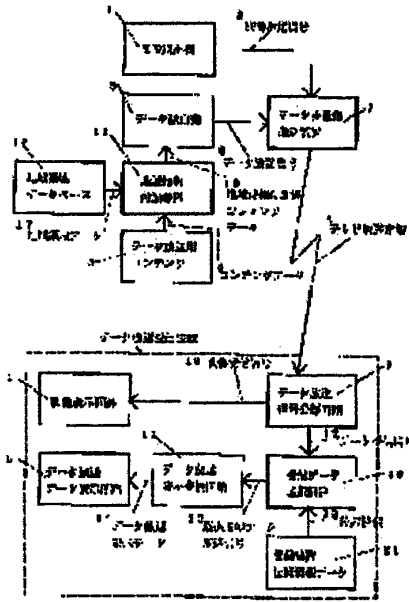

(57)Abstract:
PROBLEM TO BE SOLVED: To provide a data broadcasting equipment that can automatically select and display information limited to an area around a setting position from information of data broadcasting broadcast over a wide range.
SOLUTION: An area information addition device 18 adds area information data 17 to contents data 4 to obtain area information added contents 19 and a data transmitter 5 converts the contents 19 into a data broadcast signal 6. A data multiplexer carrying device 7 multiplexes the data broadcast signal 6 onto a video broadcast signal 2 and the result is transmitted as a television broadcast radio wave 8. A data broadcast demultiplexer circuit 9 receiving the radio wave 8 demultiplexes it into a video reception signal 10 and a data reception signal 12, the video reception signal 10 is displayed on

a video display circuit 11 and the data reception signal 12 is fed to a reception data selection circuit 20, which gives a data broadcast signal 22 to a data broadcast display conversion circuit 13, which converts the signal 22 into data broadcast display data 14 when position information 22 denotes a receptive area and a data broadcast display circuit 5 displays the data broadcast reception data 14.

Partial Translation of Reference 5

Jpn. Pat. Appln. KOKAI Publication No. 2000-165826

Filing No.: 10-335504
Filing Date: November 26, 1998
Applicant: NEC HOME ELECTRONICS LTD
Priority: Not Claimed
KOKAI Date: June 16, 2000
Request for Examination: Not filed
Int.Cl.: H04N 7/08
 7/081
 H04H 1/00
 H04N 5/44

[A]

Column 4, Line 26 to Column 5, Line 8

[0020] In addition, as shown in FIG. 3, a local information adding means is realized in a manner that a local area database 16 is created by way of methods such as rectangular, circular, ring shapes for areas to which a content is broadcasted, and the local area database 16 is added to each broadcasting content and broadcasting the contents. In FIG. 3, Area A is formed in a rectangular shape and has a broadcasting area in a range defined by a latitude a2 and a longitude a1 on one corner, and a3 in an east-west direction and a4 in a south-north direction, Area B is formed in a circular shape, and has a broadcasting area in a range of b3 radius from a center positioned at a longitude b2 and a latitude b1, and Area C is formed in an annular shape and has a broadcasting area in a range of c4 radius from a center positioned at a longitude c2 and a latitude c1 excluding a range of c3 radius from the center (area setting method other than rectangular, circular, and ring shapes can be used as a matter of course).

[0021] Further, an embodiment of the present invention includes a broadcasting content (1) for Area A, a broadcasting content (2) for all areas, a broadcasting content (3) for Area C, a broadcasting content (4) for Area B, and a broadcasting content (5) for all areas. FIG. 4 shows on or off of content display at installation positions of a receiver R1 and a receiver R2. The receiver R1 is positioned in Area A on the map. When the receiver R1 receives the contents (1) to (5) of a data receiving signal 12, the contents (1), (2), and (5) that are targeted to Area A are selected by the receiving data selection circuit 20 shown in FIG. 1. The contents (3) and (4) targeted to areas other than Area A are erased by the receiving data selection circuit 20 shown in FIG. 1, and are not to be a receiving target.

[0022] The receiver R2 is positioned in areas that do not belong to any of Area A, Area B, and Area C on the map. When the receiver R2 receives the contents (1) to (5) of the data receiving signal 12, the receiving data selection circuit 20 shown in FIG. 1 selects only the contents (2) and (5) targeted to all areas. The contents (1), (3), and (4) that are targeted to Area A, Area B, and Area C are erased by the receiving data selection circuit 20 shown in FIG. 1 and not to be a receiving target. Accordingly, contents that are closely related to the area are automatically displayed.

INFORMATION DISCLOSURE STATEMENT BY APPLICANT (Not for submission under 37 CFR 1.99)	Application Number		
	Filing Date		2011-12-05
	First Named Inventor	Wood, et al.	
	Art Unit		
	Examiner Name		
	Attorney Docket Number		ENIT 9834C2

U.S. PATENTS						Remove
Examiner Initial*	Cite No	Patent Number	Kind Code ¹	Issue Date	Name of Patentee or Applicant of cited Document	Pages, Columns, Lines where Relevant Passages or Relevant Figures Appear
	1					

If you wish to add additional U.S. Patent citation information please click the Add button. Add

U.S. PATENT APPLICATION PUBLICATIONS						Remove
Examiner Initial*	Cite No	Publication Number	Kind Code ¹	Publication Date	Name of Patentee or Applicant of cited Document	Pages, Columns, Lines where Relevant Passages or Relevant Figures Appear
	1					

If you wish to add additional U.S. Published Application citation information please click the Add button. Add

FOREIGN PATENT DOCUMENTS								Remove
Examiner Initial*	Cite No	Foreign Document Number ³	Country Code ² j	Kind Code ⁴	Publication Date	Name of Patentee or Applicant of cited Document	Pages, Columns, Lines where Relevant Passages or Relevant Figures Appear	T ⁵
	1	441720	JP		2000-08-18			<input type="checkbox"/>
	2	0030379	WO		2000-05-25			<input type="checkbox"/>
	3	9605678	WO		1996-02-22			<input type="checkbox"/>

INFORMATION DISCLOSURE STATEMENT BY APPLICANT (Not for submission under 37 CFR 1.99)	Application Number		
	Filing Date		2011-12-05
	First Named Inventor	Wood, et al.	
	Art Unit		
	Examiner Name		
	Attorney Docket Number		ENIT 9834C2

4	9849661	WO		1998-11-05			<input type="checkbox"/>
5	0145061	WO		2001-06-21			<input type="checkbox"/>
6	0157724	WO		2001-08-09			<input type="checkbox"/>
7	0189150	WO		2001-11-22			<input type="checkbox"/>
8	0371392	WO		2003-08-28			<input type="checkbox"/>
9	0377063	WO		2003-09-18			<input type="checkbox"/>
10	0579421	WO		2005-09-01			<input type="checkbox"/>
11	0915598	EP		1999-09-12			<input type="checkbox"/>
12	1032148	EP		2000-08-30			<input type="checkbox"/>
13	1071296	EP		2001-01-24			<input type="checkbox"/>
14	1515512	EP		2005-03-16			<input type="checkbox"/>

INFORMATION DISCLOSURE STATEMENT BY APPLICANT (Not for submission under 37 CFR 1.99)	Application Number		
	Filing Date		2011-12-05
	First Named Inventor	Wood, et al.	
	Art Unit		
	Examiner Name		
	Attorney Docket Number		ENIT 9834C2

If you wish to add additional Foreign Patent Document citation information please click the Add button			Add
NON-PATENT LITERATURE DOCUMENTS			Remove
Examiner Initials*	Cite No	Include name of the author (in CAPITAL LETTERS), title of the article (when appropriate), title of the item (book, magazine, journal, serial, symposium, catalog, etc), date, pages(s), volume-issue number(s), publisher, city and/or country where published.	T ⁵
	1	3rd Generation Partnership Project TS 23.246, Release 6, September 2004	<input type="checkbox"/>
	2	Bharat Sanchar Nigam Limited, "Value Added Services in GSM", Engineering Instruction, 04 May 2005; http://www.bsnl.co.in/service/mobile voice based service.htm	<input type="checkbox"/>
	3	British Parliament Debates CellAlert Service for the UK, May 13, 2003, www.ceasa.us/news.htm	<input type="checkbox"/>
	4	Canadian Contract No. 5007441, 23 July 2003; http://72.14.203.104/search?q=cache:piSqEswBv74J:strategis.ic.gc.ca/epic/internet/inet-td	<input type="checkbox"/>
	5	Canadians want Emergency-Location Services, by Dave Ebner, April 11, 2003, www.ceasa.us/news.htm	<input type="checkbox"/>
	6	CEASA, "Cell Alert System Via Cell Broadcast, Wood, September 2005, www.eglobalconf.net/speeches/MarkWood.ppt	<input type="checkbox"/>
	7	CEASA; News and Events, "News", 14 January 2005-June 2005, http://www.ceasa-international.org/news.html	<input type="checkbox"/>
	8	CEASA, "Text Message Broadcasts Could Provide Disaster Alerts" 28 July 2005, http://ceasa-international.com/usa/index2.php?option=comcontent&task=view&id=1&Ite	<input type="checkbox"/>
	9	CEASA International, "Public Warnings Via Cell Broadcast". Wood and Weiser, 24 May 2005, http://www.ceasa-int.org	<input type="checkbox"/>

INFORMATION DISCLOSURE STATEMENT BY APPLICANT (Not for submission under 37 CFR 1.99)	Application Number		
	Filing Date		2011-12-05
	First Named Inventor	Wood, et al.	
	Art Unit		
	Examiner Name		
	Attorney Docket Number		ENIT 9834C2

10	CEASA International, "Welcome to CEASa USA", Ceasa Admin, 12 June 2004, http://ceasa-international.com	<input type="checkbox"/>
11	Cellular Emergency Alert Services Association, Febraury 21, 2003, CellAlert Services Corporate Structure, www.ceasa.us/news.htm	<input type="checkbox"/>
12	Chinese Office Action (page 1 with cited reference EP 1032148)	<input type="checkbox"/>
13	CSEC "wireless Implementation & Maintenance, Service Notification & Testing Notification Policies and Procedures", 19 April 2002, http://www.911.state.tx.us/files/pdfs/resources/call_take.xls	<input type="checkbox"/>
14	Deaf Today, "Disability Group Backs Cingular/AWS Merger, Silva, 04 June 2004, http://www.deaftoday.com/news/archives/004848.html	<input type="checkbox"/>
15	Engadget, "Dutch Testing Geo-Targeted SMS Emergency Broadcast System", Ricker, 08 October 2005, http://engadget.com/entry/12340005900692252	<input type="checkbox"/>
16	ETSI TS 123.246, Universal Mobile Telecommunications Systems (UMTS); Multimedia Broadcast/Multicast Service (MBMS); Architecture and functional description (3GPP TS 23.246 version 6.6.0 Release 6) (2005-03)	<input type="checkbox"/>
17	Global Amateur Radio Emergency Communications Conference, Tampere, Finland, 13-14 June 2005, "What is 'Cell Broadcasting' and Why do I care, as a HAM?", Wood, www.rientola.fi/oh3ag/garec/documents/Cellalert.ppt	<input type="checkbox"/>
18	International Search Report, date of mailing July 17, 2006 received from the International Searching Authority	<input type="checkbox"/>
19	International Telecommunication Union, "Cell Broadcast Broker System" M. Wood, Cell Alert Services Corp., 18 Feb 2003, http://www.itu.int/itudoc/itu-t/workshop/ets/isd3-001.html	<input type="checkbox"/>
20	Messaging Network, Bercut Limited, "Broadcast for the Masses", Sergey Ermilov, 2 March 2005, http://www.bercut.biz	<input type="checkbox"/>

INFORMATION DISCLOSURE STATEMENT BY APPLICANT (Not for submission under 37 CFR 1.99)	Application Number		
	Filing Date		2011-12-05
	First Named Inventor	Wood, et al.	
	Art Unit		
	Examiner Name		
	Attorney Docket Number		ENIT 9834C2

21	MobileIN.com Perspective, "Cell Broadcasting Technical Primer", Wood, September 2005, http://www.mobilein.com/Perspectives/Authors/CB_Primer.htm	<input type="checkbox"/>
22	MobileIN.com Perspective, "History and Importance of Cell Broadcast", Wood, September 2005, http://www.mobilein.com/Perspectives/Authors/CB_HistoryImportance.htm	<input type="checkbox"/>
23	News from Senator John Edwards, North Carolina, April 3, 2003, Senate Okays Edwards Emergency Warning Bill, www.ceasa.us/news.htm	<input type="checkbox"/>
24	Newscientist.com, "Text Message Broadcasts Could Provide Disaster Alerts", 06 January 2005, http://www.newscientist.com/article.ns?id=dn6852	<input type="checkbox"/>
25	OCG-EMTEL Archives, "Cell Broadcast Public Demonstration in USA Successful", Wood, 19 September 2004, http://list.etsi.fr/scripts/wa.exe?A2=ind0409&L=ocg_emptel&T=O&F=&S=&P=693	<input type="checkbox"/>
26	RCR, Cell-Broadcast Service Gets Second Look, Jeffrey Silva, November 10, 2003, www.ceasa.us/news.htm	<input type="checkbox"/>
27	Recommendation 12 (WTDC-02), The World Telecommunication Development Conference (Instabul 2002)	<input type="checkbox"/>
28	SMS News, "Text Message Broadcasts Could Provide Disaster Alerts", 07 January 2005, http://www.sendsmsnow.com/newspage.php?id=44	<input type="checkbox"/>
29	Stanford Univeristy, EE179 "Introduction to Communications, Professor Andrea Goldsmith, Winter 2005, http://www.stanford.edu/class/ee179	<input type="checkbox"/>
30	TeliaSonera, "Mobile Broadcast/Multicast Service (MBMS)", MediaLab, August 2004, www.medialab.sonera.fi	<input type="checkbox"/>
31	Text Message Warns of "killer flu" hot spots, April 20, 2003, www.ceasa.us/news.htm	<input type="checkbox"/>

INFORMATION DISCLOSURE STATEMENT BY APPLICANT (Not for submission under 37 CFR 1.99)	Application Number			
	Filing Date		2011-12-05	
	First Named Inventor	Wood, et al.		
	Art Unit			
	Examiner Name			
	Attorney Docket Number		ENIT 9834C2	

	32	The Cellular Emergency Alert Services Association Policy Statement, August 5, 2002, http://www.ceasa.us/news.htm	<input type="checkbox"/>
	33	The Wall Street Journal Online, Local Governments Look to Cellphone-Based Alerts, Carl Bialik, June 12, 2003, www.ceasa.us/news.htm	<input type="checkbox"/>

If you wish to add additional non-patent literature document citation information please click the Add button **Add**

EXAMINER SIGNATURE

Examiner Signature		Date Considered	
--------------------	--	-----------------	--

*EXAMINER: Initial if reference considered, whether or not citation is in conformance with MPEP 609. Draw line through a citation if not in conformance and not considered. Include copy of this form with next communication to applicant.

¹ See Kind Codes of USPTO Patent Documents at www.USPTO.GOV or MPEP 901.04. ² Enter office that issued the document, by the two-letter code (WIPO Standard ST.3). ³ For Japanese patent documents, the indication of the year of the reign of the Emperor must precede the serial number of the patent document. ⁴ Kind of document by the appropriate symbols as indicated on the document under WIPO Standard ST.16 if possible. ⁵ Applicant is to place a check mark here if English language translation is attached.

**INFORMATION DISCLOSURE
STATEMENT BY APPLICANT**
(Not for submission under 37 CFR 1.99)

Application Number		
Filing Date		2011-12-05
First Named Inventor	Wood, et al.	
Art Unit		
Examiner Name		
Attorney Docket Number	ENIT 9834C2	

CERTIFICATION STATEMENT

Please see 37 CFR 1.97 and 1.98 to make the appropriate selection(s):

That each item of information contained in the information disclosure statement was first cited in any communication from a foreign patent office in a counterpart foreign application not more than three months prior to the filing of the information disclosure statement. See 37 CFR 1.97(e)(1).

OR

That no item of information contained in the information disclosure statement was cited in a communication from a foreign patent office in a counterpart foreign application, and, to the knowledge of the person signing the certification after making reasonable inquiry, no item of information contained in the information disclosure statement was known to any individual designated in 37 CFR 1.56(c) more than three months prior to the filing of the information disclosure statement. See 37 CFR 1.97(e)(2).

- See attached certification statement.
- The fee set forth in 37 CFR 1.17 (p) has been submitted herewith.
- A certification statement is not submitted herewith.

SIGNATURE

A signature of the applicant or representative is required in accordance with CFR 1.33, 10.18. Please see CFR 1.4(d) for the form of the signature.

Signature	/David L. Howard/	Date (YYYY-MM-DD)	2011-12-05
Name/Print	David L. Howard	Registration Number	41502

This collection of information is required by 37 CFR 1.97 and 1.98. The information is required to obtain or retain a benefit by the public which is to file (and by the USPTO to process) an application. Confidentiality is governed by 35 U.S.C. 122 and 37 CFR 1.14. This collection is estimated to take 1 hour to complete, including gathering, preparing and submitting the completed application form to the USPTO. Time will vary depending upon the individual case. Any comments on the amount of time you require to complete this form and/or suggestions for reducing this burden, should be sent to the Chief Information Officer, U.S. Patent and Trademark Office, U.S. Department of Commerce, P.O. Box 1450, Alexandria, VA 22313-1450. **DO NOT SEND FEES OR COMPLETED FORMS TO THIS ADDRESS. SEND TO: Commissioner for Patents, P.O. Box 1450, Alexandria, VA 22313-1450.**

Privacy Act Statement

The Privacy Act of 1974 (P.L. 93-579) requires that you be given certain information in connection with your submission of the attached form related to a patent application or patent. Accordingly, pursuant to the requirements of the Act, please be advised that: (1) the general authority for the collection of this information is 35 U.S.C. 2(b)(2); (2) furnishing of the information solicited is voluntary; and (3) the principal purpose for which the information is used by the U.S. Patent and Trademark Office is to process and/or examine your submission related to a patent application or patent. If you do not furnish the requested information, the U.S. Patent and Trademark Office may not be able to process and/or examine your submission, which may result in termination of proceedings or abandonment of the application or expiration of the patent.

The information provided by you in this form will be subject to the following routine uses:

1. The information on this form will be treated confidentially to the extent allowed under the Freedom of Information Act (5 U.S.C. 552) and the Privacy Act (5 U.S.C. 552a). Records from this system of records may be disclosed to the Department of Justice to determine whether the Freedom of Information Act requires disclosure of these records.
2. A record from this system of records may be disclosed, as a routine use, in the course of presenting evidence to a court, magistrate, or administrative tribunal, including disclosures to opposing counsel in the course of settlement negotiations.
3. A record in this system of records may be disclosed, as a routine use, to a Member of Congress submitting a request involving an individual, to whom the record pertains, when the individual has requested assistance from the Member with respect to the subject matter of the record.
4. A record in this system of records may be disclosed, as a routine use, to a contractor of the Agency having need for the information in order to perform a contract. Recipients of information shall be required to comply with the requirements of the Privacy Act of 1974, as amended, pursuant to 5 U.S.C. 552a(m).
5. A record related to an International Application filed under the Patent Cooperation Treaty in this system of records may be disclosed, as a routine use, to the International Bureau of the World Intellectual Property Organization, pursuant to the Patent Cooperation Treaty.
6. A record in this system of records may be disclosed, as a routine use, to another federal agency for purposes of National Security review (35 U.S.C. 181) and for review pursuant to the Atomic Energy Act (42 U.S.C. 218(c)).
7. A record from this system of records may be disclosed, as a routine use, to the Administrator, General Services, or his/her designee, during an inspection of records conducted by GSA as part of that agency's responsibility to recommend improvements in records management practices and programs, under authority of 44 U.S.C. 2904 and 2906. Such disclosure shall be made in accordance with the GSA regulations governing inspection of records for this purpose, and any other relevant (i.e., GSA or Commerce) directive. Such disclosure shall not be used to make determinations about individuals.
8. A record from this system of records may be disclosed, as a routine use, to the public after either publication of the application pursuant to 35 U.S.C. 122(b) or issuance of a patent pursuant to 35 U.S.C. 151. Further, a record may be disclosed, subject to the limitations of 37 CFR 1.14, as a routine use, to the public if the record was filed in an application which became abandoned or in which the proceedings were terminated and which application is referenced by either a published application, an application open to public inspections or an issued patent.
9. A record from this system of records may be disclosed, as a routine use, to a Federal, State, or local law enforcement agency, if the USPTO becomes aware of a violation or potential violation of law or regulation.

整理番号: _____ 発送番号:441720 発送日:平成21年 7月 7日 _____ 1

Ref 6

引用非特許文献

特許出願の番号	特願2006-553357
作成日	平成21年 7月 1日
作成者	川口 貴裕 3055 5J00
発明の名称	公共サービスメッセージの放送システム及び方法

本複製物は、特許庁が著作権法第42条第2項第1号の規定により複製したものです。
 複製にあたっては、著作権者との同意を得るよう十分ご注意ください。

Matsushita Technical Journal Vol. 48 No. 4 Aug. 2000

557

UDC 621.397.74:681.3
 30.165



可児市「コミュニティネットかに」システム

Kani City "Community Net Kani" System

梅影 信隆* 後藤 敏雄* 鷲坂 教*

Nobutaka Umezake Toshio Gotō Atsushi Sagisaka

菅井 洋一郎* 末廣 亮太*

Yūchirō Sugai Ryōta Suehiro

要 旨

「コミュニティネットかに」システムは、岐阜県可児市が平成9年度から平成11年度の3カ年で「先進的情報通信システムモデル都市構築事業」として構築した地域情報化システムである。既存の都市型CATV網をHFC (Hybrid Fiber and Coaxial) 化し、LAN対応とすることで、市役所と公共施設、市民家庭をネットワーク化するとともに、インターネット、公衆網、既存の防災ネットワークと有機的に接続することで、市内を網羅したマルチメディアイントラネットを構築した。

また、高速通信を活用したTV電話による行政相談・学校間交流、公共スポーツ施設予約などの市民情報、学習情報、健康福祉、防災情報、市政情報を提供する各種アプリケーションを開発し、マルチメディアイントラネットに連携構築した。本システムは、市内に設置した街頭端末、公共施設や家庭のパーソナルコンピュータはもとより、家庭のFAXや電話から情報を入手したり、登録することができる市民参加型の複合システムである。

Abstract

"Community Net Kani" is a community information system that Kani City, Gifu Prefecture, has been constructing as an "advanced information communication system improvement enterprise" since 1997. By changing the urban CATV network to HFC (Hybrid Fiber and Coaxial) to suit a LAN system, network communication has been established among public institutions, the city office, and homes. Furthermore, by connecting the Internet, telephone network and disaster prevention network, we are able to exchange information between homes and the Internet world as a multimedia intranet that covers the entire city.

We have designed many applications such as administrative consultation, communication among schools, public facility reservation system, self-study support system, safety information, and administrative information. This is a citizen-participation system built into a multimedia network. The system helps us to obtain and register information through street terminals in the city, personal computers in homes and public facilities and even fax machines and telephones in homes.

1. 結 言

可児市では、全国の地方自治体に先駆けて、平成3年

*システムソリューション事業本部
 Corporate Systems Solutions Div.

に「しなやかで魅力あふれる情報交流都市・可児」をビジョンとした地域情報計画の策定が行われ、「広く暮らしの基礎情報を提供するとともに、市民の参加によるふれあいと連帯感のあるコミュニケーションを支援することで、地域の情報発信力を高める」ことを目的としたシステムの構築が検討された。

17

本複製物は、特許庁が著作権法第42条第2項第1号の規定により複製したものです。
複製物のすべては、著作権者とならなれども十分に注意を払って複製されたものと見做すものとす。

可見市は名古屋市から約30 km に位置し、その衛星都市としてベットタウン化が進み、人口が急増するとともに、県下有数の工業団地や大規模小売店の進出などにより急速な都市化が進んでいる。人口の急増による市民の価値観の多様化、従来からの地縁による自治会などのコミュニティ活動の低下が生じている一方で、生活圏の広域化、教育の高度化による地域を越えた新しい市民交流が進み始めている。市民と行政がより身近に情報交流ができ、市民が主体的に情報活動に参加できる環境の整備、次代を担う世代の情報分野での育成を目的とした、市民が進んで情報発信が行える市民参加型の新しい情報交流サービスを提供できるシステムが必要とされていた。

このような背景のもとで、平成8年度に「コミュニティネットかに」システムを構築するための可見市の現状・課題の調査分析、将来の拡張性を考慮した基本調査報告書を作成した。平成9年度に「先進的情報通信システムモデル都市構築事業」として、日本電信電話株式会社のもとでネットワーク系・サーバ系を含む庁内システム、防災ネットワーク連携の構築を主体に、また平成10年度と11年度に当社でアプリケーション系を担当し、平成12年3月で事業を完了した。

2. システムコンセプト

「コミュニティネットかに」システムのシステム要件は、以下の6点である。

- ①情報交流機能の基幹機能を構築する。
 - ②CATV 網を情報通信基盤として活用する。
 - ③市民が家庭からパーソナルコンピュータ以外の手段でも情報交流ができる。
 - ④インターネットへの提供情報が家庭のTVでも閲覧できる。
 - ⑤既存防災無線システムとのデータ連携を行う。
 - ⑥市民との情報交流、市民への情報提供等のアプリケーションサービスを提供する。
- パーソナルコンピュータ以外で情報交流を行う仕組みとして、家庭で使い慣れている電話、FAX を使用するこ

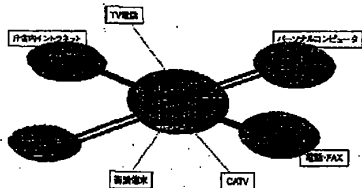

第1図 システムコンセプト
Fig.1 System concept.

とにした。上記システム要件を満たすシステムとして、インターネット、CATV 網、電話・FAX を接続する公衆網、防災ネットワークの異なるメディアを有機的に組み合わせた「情報バリアフリー」をシステムコンセプトとした。

システムコンセプトを第1図に示す。

3. システム概要

本章で、ハードウェアとアプリケーションシステムの構成とその概要について述べる。

3.1 ハードウェアシステム構成

「コミュニティネットかに」システムは、大別して下記の3システムで構成している。

- (1)基幹システムとなる公衆系・非公衆系の各種サーバを設置したネットワークセンタと市役所間をATMで接続し、職員端末系を無線LANで構築した庁内システム
- (2)市内92%に敷設されたCATV 網をHFC化し、双方向の高速情報通信網として、市役所、公共施設、市民家庭をネットワーク化したCATV-LAN
- (3)既設の市内外に設置した雨量・水位観測データなどを送信する防災ネットワーク

さらに、OCNによるインターネット接続、電話・FAXで情報の入手や発信を可能とした公衆網接続、市外とのTV 電話を行う手段として安定した通信速度が確保できるISDN 網を接続している。

システムの構成を第2図に示す。

3.2 アプリケーションシステム

本システムは、アプリケーションとして下記に述べる6機能のカテゴリ別サービスとイントラネットシステムで構成している。

第3図に、アプリケーションシステムの構成を示す。

3.2.1 市民情報システム

市民が情報発信の主体となって、市民と市役所、地域産業界をインターネットで広く情報交流を行うシステムである。

「市役所への質問・提言」、「市長への手紙」や「市民掲示板」などのコミュニケーション手段をインターネット上に公開し、行政、地域産業界や市民との間で情報共有と交流を行う。これらの情報はFAXでも取出し・登録することが可能である。また、これらの市民からの情報はCATV 放送で放送する。

3.2.2 学習情報システム

市民への生涯学習の啓蒙と次代の情報を担う世代の育

本複製物は、特許庁が著作権法第42条第2項第1号の規定により複製したものです。複製にあたっては、著作権侵害をしないよう十分に注意ください。

複製権: 可児市「コミュニティネットワーク」システム

38

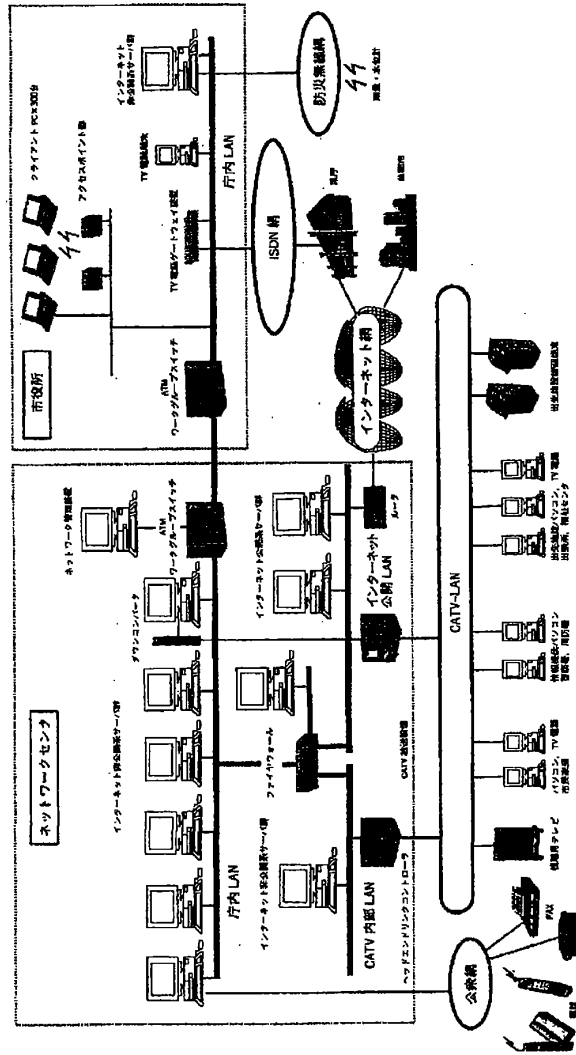

第2図 システム構成
Fig. 2 Hardware system.

19

本複製物は、特許庁が著作権法第42条第2項第1号の規定により複製したものです。
なお、複製には、著作権者との同意を得る必要があります。

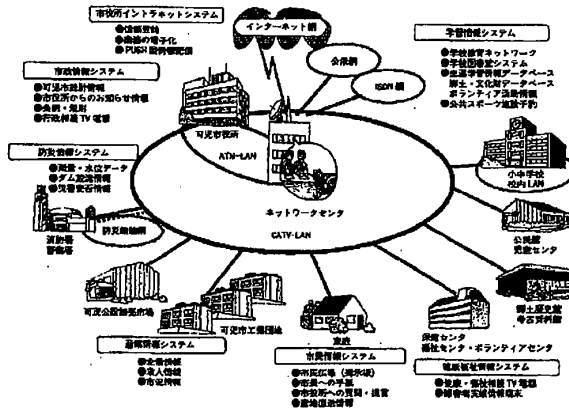

第3図 アプリケーション構成 Fig.3 Application system.

成を主眼としたシステムで、次のような特徴を有する。

- (1)郷土史、有形文化財、天然記念物などの情報や市民クラブ、各ボランティア団体の活動状況の紹介、市やボランティアが主催する講座の案内などの学習情報を画像やPDFデータとして提供する。これらの情報は「生涯学習情報データベース」として一括管理し、階層検索や全文検索手段とともに市民へ提供する。
- (2)市が管理するスポーツ施設の効率良い公平な利用のために、抽選や施設の利用空き情報を提示する。また、施設管理者への各種ユーティリティの提供により、施設管理の効率化と利用促進をはかる。市民からの利用申込み等はインターネットと電話で行える。
- (3)市立小中学校15校ごとにLANを構築し、かつ学校間を連携させた学校教育ネットワークを構築。インターネット、各学校図書館システムやTV電話を利用した学校間交流などの情報教育の場を提供する。

3.2.3 健康福祉情報システム

- 高齢者または障害をもつ方への支援システムであり、次のような特徴を有する。
- (1)高齢者または障害をもつ方などの要介護家庭と保健機関や福祉施設とを1対1によるTV電話で接続する。従来の音声だけでなく、画像を交えた在宅ケア相談サービスや薬師訓練施設に登校できない児童とのコミュニケーションを行う。
- (2)身体に障害をもつ方が、障害の内容に応じて利用しやすいように工夫された入力機器を接続した端末を利用することで情報が入手できる。

3.2.4 防災情報システム

- 市民への防災に対する啓蒙促進と災害情報発生時の安否情報の提供を行うシステムであり、次のような特徴を有する。
- (1)市内外14カ所の雨量、2カ所の河川水位データと、ダムの放流水量や放流時間を市内地図の上に重ね合わせて公開する。
- (2)地震などの災害発生時に、避難した市民の安全確認や被害情報等を市民自らの音声やFAXで情報登録ができ、遠隔地から安全確認ができる。

3.2.5 産産情報システム

- 可見市の企業や公設卸売市場からの情報を提供するシステムであり、次のような特徴を有する。
- (1)地場産業や可見市工業団地の企業などによる企業情報、イベント情報の公開や企業の求人情報の紹介を行う。
- (2)可茂公設卸売市場の卸売り価格など主要品目の市況情報を集計編纂し、取り引き終了後に公開し、過去3年間のデータをCSVデータで提供する。

3.2.6 市政情報システム

- 市役所から暮らしの基盤となる情報を提供するシステムであり、次のような特徴を有する。
- (1)乳幼児検診、児童手当、リサイクルの案内など、「くらしの役立つ情報」、「可見市統計情報」、「市役所からのお知らせ」、「市の条例・規則」、「市議会会議録」などの行政からの情報を公開する。
- (2)市役所の連絡所に訪れた市民の行政に関する質問な

本複製物は、特許庁が著作権法第42条第2項第1号の規定により複製したものです。
 複製にあたっては、著作権侵害とみなされないよう十分に注意してください。

編者 他: 可児市「コミュニティネットかに」システム

561

ど、連絡所から市役所担当課と直接 TV 電話で相談を受けることができる。映像や音声のほか、ワード、エクセル等のデータを利用したコミュニケーションも同時に利用可能としている。

3.2.7 市役所イントラネットシステム

市政情報を公開するための手段と、市役所業務の電子化、効率化を行うシステムで、次のような特徴を有する。

- (1)各課、係や公共施設へ端末を設置し、市役所情報の一元化とホームページへの登録機能をもたせている。
- (2)市役所業務の電子化、効率化を促進する機能として、公用車・会議室予約、時間外・旅費申請システムなどをノーツのワークフローを応用して構築した。また、市職員に、緊急に連絡すべき情報を登録した時点で指定された端末に、自動で配信するプッシュ型の情報配信システムを搭載している。

4. システムの特徴

「コミュニティネットかに」システムが特徴とする内容について述べる。

4.1 庁内 LAN

本システムの基幹となる各種サーバ機器と職員用端末などで構成される LAN であり、各種サーバ機器を設置したネットワークセンタと市役所庁舎を ATM で接続している。

4.1.1 ATM

ATM は、ATM フォーラム MPOA (Multi Protocol Over ATM) に準拠した機種を採用した。ATM の特徴は、次のとおりである。

- (1)音声、画像、LAN 間通信、圧縮ビデオ信号などの多様なメディアに対応。
 - (2)ATM カットスルーによるルーティングの高速化とスイッチの増設拡張性。
 - (3)VLAN 設定、ルーティング設定、端末アドレス情報を集中管理できることで、ネットワーク監視装置から設定/参照が容易となり、管理保守性が向上。
- ATM 構成機器仕様を第 1 表に示す。

4.1.2 庁内 LAN

庁内 LAN は 100Base-TX/10Base-T で構成しているが、職員端末は庁内でのレイアウト変更などによる遷移工事の煩わしさの一掃と庁内でのモバイル性を重視し、無線 LAN で構築している。無線 LAN は有線 LAN に比較して通信速度が劣るため、基地局であるアクセスポイントへ接続する端末台数を制限することで、レスポンスの低下を軽減している。

第 1 表 ATM 構成機器の仕様仕様
 Table1 Specifications of ATM system component.

名称/項目	概 要
Work Group Switch	
スイッチ容量	1.6 Gbps
スイッチ方式	ノンブロッキングスイッチ
ATM セル仕様	ITU-T 勧告 L361準拠
接続形態	PVC, SVC
輻射制御	ABR, CBR, VBR, UBR
ATM I/F ポート数	12ポート
通信速度	155 Mbps
Orange Ridge	
ATM セル仕様	ITU-T 勧告 L361準拠
接続形態	SVC
LAN エミュレーション	MPOA, LANEmulation V2.0
NW 管理プロトコル	CPSS
ATM I/F ポート数	1
LAN I/F 数	12
LAN 通信速度	10/100 Mbps (自動認識)
Yellow Ridge	
ATM セル仕様	ITU-T 勧告 L361準拠
接続形態	SVC
LAN エミュレーション	MPOA, LANEmulation V1.0
NW 管理プロトコル	CPSS
ATM I/F ポート数	1
LAN I/F 数	12
LAN 通信速度	10 Mbps
System Manager	
管理プロトコル	CPSS, SNMP (OpenView4.1)
ATM I/F ポート数	1
通信速度	155 Mbps
Route Server	
LAN エミュレーション	MPOA, LANEmulation V2.0
サポートプロトコル	IEEE802.1d トランスパレント・ブリッジ IP
その他機能	ブロードキャストパケット対応
ATM I/F ポート数	1
通信速度	155 Mbps

4.2 CATV-LAN

CATV-LAN を構成するヘッドエンドリンクコントローラ、モデムには、大別して対称型と非対称型があり、通信速度や将来の増設対応の容易性から方式を選定する必要がある。CATV-LAN の要件として、次の事項があげられる。

- (1)可児市の人口増加率は高く、今後 CATV 加入者の増加が予測されることから、ヘッドエンドリンクコントローラが低価格で増設可能であること。
- (2)市役所、公共施設と家庭で利用する TV 電話による音声と映像など、端末から多量のデータを高速に送出で

本複製物は、特許庁が著作権法第42条第2項第1号の規定により複製したものです。
 取扱いについては、著作権者からのお知らせをご覧ください。

382

Matsushita Technical Journal Vol. 46 No. 4 Aug. 2000

きること。

本システムでは、上記の要件を、比較的低価格で具現化できる対称型ヘッドエンドリンクコントローラとモデムで具現化している。市内のCATV網を13ノードに分割し、流合雑音の影響を少なくするため、1ノード当たりの端末台数は1000台以下としている。

また、CATVネットワークで端末機器などのネットワーク共有設定により、端末の内部データが参照できる問題があるが、モデムのフィルタリング機能で端末機器のデータの安全性を確保している。

ヘッドエンドリンクコントローラはAHLC-1000(愛知電子製)、モデムにはBMR-1000E(愛知電子製)で構築(構築業務は愛知電子で実施)している。

ヘッドエンドリンクコントローラの概略仕様を第2表に示す。

第2表 ヘッドエンドリンクコントローラの概略仕様
 Table2 Specifications of head-end link controller.

送信周波数 (MHz)	90~550 470~770
受信周波数 (MHz)	10~55
占有帯域幅 (MHz)	6
変復調方式	QPSK
伝送速度 (Mbps)	10 (ブロードバンド)
インタフェース	AUI×1 10Base-T×1

4.3 セキュリティシステム

庁舎内LANはOCNとCATV網にそれぞれ接続し、インターネットとCATV網への情報提供を行っている。市役所で扱われる情報には、住民の個人情報などの重要情報があり、市役所外への漏洩、あるいは改ざんなどの不正アクセスからの防衛が必要である。

4.3.1 ファイアウォール

本システムでは、庁舎内LAN、CATV網に対して3系統で構成するファイアウォールを構築し、インターネットやCATV網からの不正アクセスや通信データの搾取、改ざんを防止している。

ファイアウォール1は庁舎内システムを、ファイアウォール2はCATV網内のシステムを示し、それぞれインターネットユーザからの不正アクセスを防止している。また、ファイアウォール3はCATV-LANに接続された市民家庭の端末からの庁舎内システムへのアクセスを防止している。

CATV網に接続された各公共施設でも秘文書扱いの情報を取り扱っており、各施設にファイアウォール機能をもたせ、CATV網内の市民家庭からのアクセスを防止している。

4.3.2 VPN機能

CATV-LANに、市役所と公共施設間の通信データの搾取を防止するため、VPN (Virtual Private Network) を構築した。データ暗号にDES方式を使用し、鍵は一定周期で自動更新かつ改ざん検出機構付きのデータ暗号方式であり、セキュリティを確保している。

4.4 インターネット-公衆網連携機能

本機能は、パーソナルコンピュータをもたない、あるいは操作が不得手な市民でもインターネット等に公開されている情報を電話やFAXで入手したり、FAXからインターネットへ情報発信できる機能である。また、公共スポーツ予約システムと連携させ、電話でスポーツ施設の利用予約・確認を音声認識とダイヤル操作で行うことができる。

また、市役所など行政から情報を登録する場合は、掲載情報に対するセキュリティを確保するために認証を行う仕組みとしている。住民から情報登録を行う場合には、広く積極的に活用してもらえよう認証は行わない。ただし、個人への非難中傷など不適切な情報が掲載されないように、あらかじめ管理者の確認を行い、ホームページとして掲載する仕組みとしている。

本機能はインターネットFAXサーバ装置で具現化し、最大10,000件の情報が提供可能である。

以降に、FAX、パーソナルコンピュータ (WWWブラウザ) のユーザインタフェースについて記述する。

4.4.1 FAX

FAXや電話による情報の登録・取出しの操作は、音声ガイダンスとPBトーンの入力による組合わせで行う。登録情報は、情報番号で管理している。

利用者は、本システムに電話をかけ、音声ガイダンスに従って情報番号と呼ばれる番号をPBから入力し、情報の取出しや登録を行う。情報番号がわからない場合は、情報番号一覧表を取り出すこともできる。

FAXからの情報登録の操作例と情報の内部処理を以下に示す。

- ①本システムに電話をかける。
- ②音声ガイダンスに従って、あらかじめ登録された利用者番号とパスワードを入力し、利用者の認証を行う(ただし、市民から情報を登録する場合は除く)。
- ③登録したい原稿をFAXから入力する。
- ④電話を切る。
- ⑤インターネットFAXサーバが受け取ったFAXデータをホームページ用にメディア変換し、HTMLを自動で生成後管理者へ通知する。
- ⑥管理者が不適切な情報でないことを確認し、公開サーバへ登録する。

22

本複製物は、特許庁が著作権法第42条第2項第1号の規定により複製したものです。
複製にあたっては、著作権侵害と見なさないよう十分にご注意ください。

撮影 地: 可見市「コミュニティネットかに」システム

368

4.4.2 パーソナルコンピュータ

パーソナルコンピュータのブラウザからFAXで登録した情報をアクセスする場合は、通常のWWWサーバのホームページへのアクセスと同様の操作で具現化している。FAXから発信された情報は、登録順に一覧情報として「一覧HTML」と登録された「情報HTML」がインターネットFAXサーバ装置に登録されている。公開サーバのホームページに掲載している一覧HTMLのURLを指定することで、FAXから入力された情報を取り出すことができる。ホームページに掲載した情報HTMLのイメージを第4図に示す。

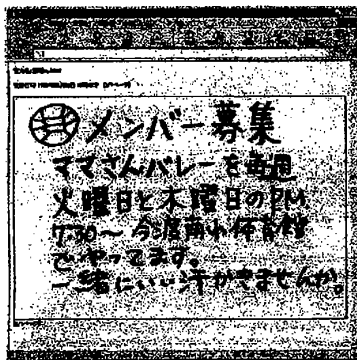

第4図 FAXから登録したホームページ
Fig.4 Display Image by Internet FAX server.

4.5 インターネット-CATV放送連携

インターネットへ提供している情報の一部をリアルタイムに住民に伝える手段として、CATV放送に「可見市市民情報」の放送チャンネルを新設した。新設したチャンネルにWWWサーバに掲載したホームページを任意に選択し、一定時間間隔で繰り返し表示させ、この情報を放送している。

本機能は非公開サーバ群に設置したCATV自動配信サーバ、WWWサーバとインターネットFAXサーバを連携し、放送したいホームページ情報をCATV自動配信サーバに取り込む。CATV自動配信サーバからダウンコンバータを経由してNTSC信号をCATV放送装置に出力している。ダウンコンバータは高解像度を具現化するため、サンプリングレート100MSPS、水平解像度1000本以上対応の機構で構成している。

最新のホームページ情報をCATV放送に反映させるため、ホームページの情報を簡単に選択登録できるよう

に、ホームページの選択はブラウザで目視確認しながら行い、表示タイミングなどの設定は専用画面で行うようにした。ホームページのCATV放送での表示時間は、10秒から99秒までを任意に選択可能とした。

編集操作画面を第5図に掲載する。

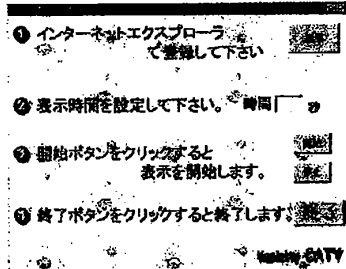

第5図 CATV放送操作画面
Fig.5 Operation image of CATV broadcasting.

4.6 インターネット-防災ネットワーク連携

市内および市外に設置した雨量、河川水位情報を公開することで市民への災害に対する啓蒙をはかるシステムである。

市内、および可見川上流の14カ所の雨量と可見川、久々利川の水位データを防災無線や専用回線で送信し、防災サーバに格納する。防災サーバでは、10分ごとに非公開サーバ群に設置した監視サーバにデータを送信し、観測場所・日付・時間ごとに編集を行う。

また、可見市上流のダムが放流する放流量、放流時間などの放流情報を雨量、水位情報と合わせて集計・編集し、リアルタイムに可見市の地図に重ね合わせてホームページに掲載表示する。

過去のデータは、学校教育用資料として利用できるように、過去3年間の雨量、水位データを観測場所、時間、日、月、年ごとに集計編集し、ダウンロードデータとして提供できるようにCSV形式でホームページに掲載している。ホームページのイメージ図を第6図に示す。

4.7 TV電話機能

本機能はCATV-LANのデータ通信の高速性を活用し、市内10カ所の市役所連絡所と市役所、市立小中学校間、福祉センターや保健センターと家庭で利用できる。

本システムでは、以下の機能を具現化している。
(1)通信速度最大768 kbpsまで対応可能であるので最大30フレーム/秒の性能が確保でき、手話(ただし、速い動きやトラフィックの利用状況などの影響によりブロッ

33

本複製物は、特許庁が著作権法第42条第2項第1号の規定により複製したものです。
取扱いについては、各情報誌とからなむより十分に注意してください。

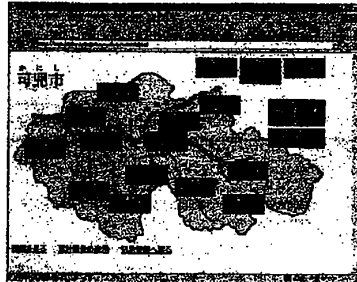

第6図 雨量・水位情報画面
Fig.6 Display image of rainfall and water level.

クノイズの発生もある。)でのコミュニケーションが提供でき、耳に障害をもつ方でも利用できる。

(2)アプリケーション共有機能をもち、スキャナやペンタブレットを接続することでイメージデータを相互に加筆修正できる。また、ワードやエクセルを相互の端末に搭載することで、文字や図表でのコミュニケーションのほか、共同作業を行うことができる。

(3)県や他都市と接続する手段として、インターネットを経由すると幹線経路やファイアウォール等の影響を受ける可能性があり、ISDNで接続する方式とした。LAN-WAN相互接続にゲートウェイ装置を導入した。ゲートウェイ装置は回線交換機能とH323とH320のプロトコル変換機能をもち、ISDNとは2B単位で増設接続を可能としている。回線を増設することで手話による会話を行うことも可能である。

第7図に、操作画面を示す。

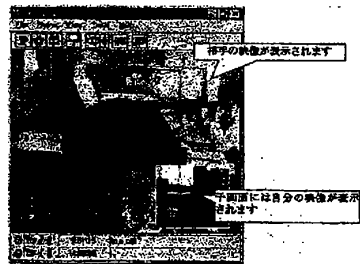

第7図 TV 電話操作イメージ
Fig.7 Operation image of TV communication.

4.8 生涯学習データベース

本機能は、市民への生涯学習の支援となる情報をデータベース化し、市民へ提供するシステムである。

提供する情報は、日本一のバラ園を管理する花フェスタ記念公園に栽培されている約700点のバラ、可児市郷土歴史館や考古資料館に収蔵されている学術性の高い遺跡、古城、ボランティア団体の活動状況の紹介や市民で構成する文化・スポーツ活動団体の紹介など、画像と解説文をデータベース化している。データの登録は最大100万件まで可能であり、情報の検索には1秒当たり3万文字の検索能力のある“Panasearch”による全文検索と階層検索で目的の情報が早く簡単に取得できるようにしている。

第8図に操作画面を示す。



第8図 生涯学習データベース階層検索画面
Fig.8 Operation image of self-study support system.

5. 結 言

以上、可児市の「コミュニティネットかに」システムの構築事例を紹介した。CATV 網を地域イントラネットとしてインターネット、公衆網や防災無線網と連携構築したマルチメディアネットワークに多様なサービスを6カテゴリに分けて提供することで、必要とする情報を即座に提供し、住民が必要とする情報を適宜入手することが可能となった。とくに、パーソナルコンピュータを利用していない家庭でも、電話やFAXを利用できることで情報交流が身近な存在になった意義は大きく、情報弱者への垣根を取り払うとともに、住民が主体的に活用する手段の1つになりえたと考えられる。今後、インターネットの普及が一段と促進され、情報化のニーズも高度化、多様化していくが、本システムを基盤としてニーズに応じたシステム構築を提供していきたいと考える。

終わりに、システムの構築にあたりご指導ご協力いただきました可児市役所市政情報課の皆様をはじめ、ご関係の皆様へ深く感謝申し上げます。

Partial Translation of Reference 6

Non-Pat. Document: Matsushita Technical Journal Vol. 46 No. 4 Aug. 2000

Jpn. Pat. Appln. No. 2006-553357

[A]

Page 7, Right Column, Line 7 to Page 8, Left Column, Line 11

4.4 Internet-Public Network Linking Function

This function allows an ordinary person who does not have a personal computer or cannot use a personal computer well to acquire information made public on the Internet by using a telephone and a facsimile, and originate information to the Internet from a facsimile. In addition, this function can be linked to a public sport reservation system, and a user can carry out reservation and confirmation of use of a sports facility by telephone by voice recognition and dial control.

In addition, when information from the administration such as a municipal office is registered, authentication is carried out for the security of published information. When information registration from a citizen is carried out, authentication is not carried out, so that this system is used widely and actively. However, in order to prevent inappropriate information, such as information offending or defaming an individual, from being published, information is published on a website after the check by an administrator.

This function is implemented by using an Internet facsimile server device, and a maximum of ten thousand pieces of information can be provided.

Hereinafter, user interfaces of a facsimile and a personal computer (WWW browser) will be described.

4.4.1 Facsimile

Operation of registration and retrieval of information by using a facsimile and a telephone is carried out by a combination of voice guidance and input of a push button (PB) tone. Registered information is managed by information numbers.

The user makes a call to this system, and follows voice guidance to input a number, which is called an information number, by using push buttons. In this manner, the user retrieves or registers information. When the user does not know an information number, the user can retrieve a list of information numbers.

Now, operation example of information registration from a facsimile and internal processing of information will be described.

- (1) The user makes a call to this system.
- (2) The user follows voice guidance to input a user number and a password registered in advance for the user authentication (except for a case where information is registered by a citizen).
- (3) The user inputs a document to be registered by using a facsimile.
- (4) The user hangs up the phone.
- (5) The FAX data received by an Internet FAX server device is converted to media supported by a website, and an HTML is automatically generated and notified to

an administrator.

(6) The administrator confirms that the information is not inappropriate, and registers the information to a public server.

4.4.2 Personal Computer

Access to information registered from a facsimile from a browser of a personal computer is performed by operation similar to access to a normal website of a WWW server. An "information HTML" registered as a "list HTML" including pieces of information originated from a facsimile as list of information in the order of registration is registered in the Internet facsimile server device. By designating a URL of the list HTML published on a website of a public server, information input from a facsimile can be retrieved. An example of an information HTML published on a website is shown in FIG. 4.



INTERNATIONAL APPLICATION PUBLISHED UNDER THE PATENT COOPERATION TREATY (PCT)

<p>(51) International Patent Classification ⁷ : H04Q 7/22</p>	<p>A1</p>	<p>(11) International Publication Number: WO 00/30379 (43) International Publication Date: 25 May 2000 (25.05.00)</p>
<p>(21) International Application Number: PCT/US99/26045 (22) International Filing Date: 4 November 1999 (04.11.99) (30) Priority Data: 09/195,374 18 November 1998 (18.11.98) US (71) Applicant: ERICSSON, INC. [US/US]; 7001 Development Drive, Research Triangle Park, NC 27709 (US). (72) Inventor: IRVIN, David, R.; 1546 Iredell Drive, Raleigh, NC 27608 (US). (74) Agent: BENNETT, David, E.; Coats & Bennett, P.L.L.C., P.O. Box 5, Raleigh, NC 27602 (US).</p>		<p>(81) Designated States: AE, AL, AM, AT, AU, AZ, BA, BB, BG, BR, BY, CA, CH, CN, CR, CU, CZ, DE, DK, DM, EE, ES, FI, GB, GD, GE, GH, GM, HR, HU, ID, IL, IN, IS, JP, KE, KG, KP, KR, KZ, LC, LK, LR, LS, LT, LU, LV, MA, MD, MG, MK, MN, MW, MX, NO, NZ, PL, PT, RO, RU, SD, SE, SG, SI, SK, SL, TJ, TM, TR, TT, TZ, UA, UG, UZ, VN, YU, ZA, ZW, ARIPO patent (GH, GM, KE, LS, MW, SD, SL, SZ, TZ, UG, ZW), Eurasian patent (AM, AZ, BY, KG, KZ, MD, RU, TJ, TM), European patent (AT, BE, CH, CY, DE, DK, ES, FI, FR, GB, GR, IE, IT, LU, MC, NL, PT, SE), OAPI patent (BF, BJ, CF, CG, CI, CM, GA, GN, GW, ML, MR, NE, SN, TD, TG).</p> <p>Published <i>With international search report.</i></p>

(54) Title: METHOD AND APPARATUS FOR LOCATION BASED TARGETING OF MESSAGES TO COMMUNICATION TERMINALS

(57) Abstract

To improve the geographic resolution of broadcast messages transmitted over a communication network, such as a cellular telephone network, the originator of a message specifies a target area of reception. The target area of reception is compared to location data usually representing the terminal location. When the location data matches the target area of reception, the terminal accepts the message; otherwise, the terminal does not accept the message. In one embodiment of the invention, location data is determined by a positioning receiver and loaded into a register. In another embodiment, the location data is loaded into the register by manual keypad entry or by transmission over the network, so that the location data can define a location of interest other than the terminal's current geographic location, or so that terminal location data can be provided for communication terminals that lack a positioning receiver.

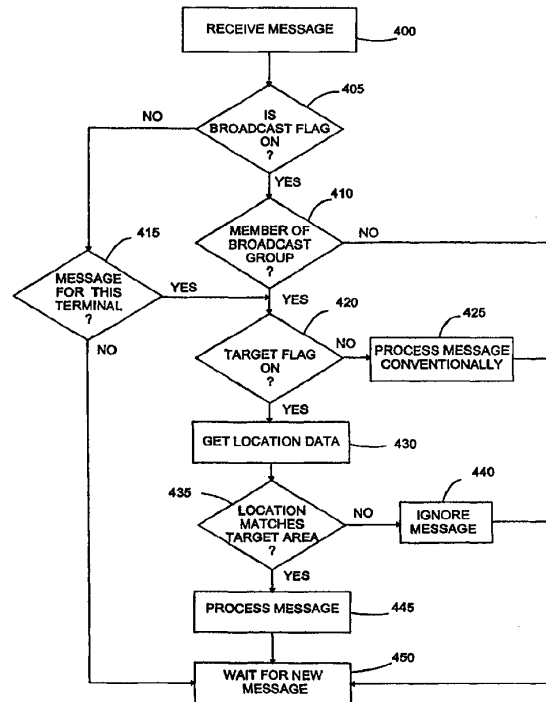

FOR THE PURPOSES OF INFORMATION ONLY

Codes used to identify States party to the PCT on the front pages of pamphlets publishing international applications under the PCT.

AL	Albania	ES	Spain	LS	Lesotho	SI	Slovenia
AM	Armenia	FI	Finland	LT	Lithuania	SK	Slovakia
AT	Austria	FR	France	LU	Luxembourg	SN	Senegal
AU	Australia	GA	Gabon	LV	Latvia	SZ	Swaziland
AZ	Azerbaijan	GB	United Kingdom	MC	Monaco	TD	Chad
BA	Bosnia and Herzegovina	GE	Georgia	MD	Republic of Moldova	TG	Togo
BB	Barbados	GH	Ghana	MG	Madagascar	TJ	Tajikistan
BE	Belgium	GN	Guinea	MK	The former Yugoslav Republic of Macedonia	TM	Turkmenistan
BF	Burkina Faso	GR	Greece	ML	Mali	TR	Turkey
BG	Bulgaria	HU	Hungary	MN	Mongolia	TT	Trinidad and Tobago
BJ	Benin	IE	Ireland	MR	Mauritania	UA	Ukraine
BR	Brazil	IL	Israel	MW	Malawi	UG	Uganda
BY	Belarus	IS	Iceland	MX	Mexico	US	United States of America
CA	Canada	IT	Italy	NE	Niger	UZ	Uzbekistan
CF	Central African Republic	JP	Japan	NL	Netherlands	VN	Viet Nam
CG	Congo	KE	Kenya	NO	Norway	YU	Yugoslavia
CH	Switzerland	KG	Kyrgyzstan	NZ	New Zealand	ZW	Zimbabwe
CI	Côte d'Ivoire	KP	Democratic People's Republic of Korea	PL	Poland		
CM	Cameroon	KR	Republic of Korea	PT	Portugal		
CN	China	KZ	Kazakhstan	RO	Romania		
CU	Cuba	LC	Saint Lucia	RU	Russian Federation		
CZ	Czech Republic	LI	Liechtenstein	SD	Sudan		
DE	Germany	LK	Sri Lanka	SE	Sweden		
DK	Denmark	LR	Liberia	SG	Singapore		
EE	Estonia						

METHOD AND APPARATUS FOR LOCATION BASED TARGETING OF MESSAGES TO COMMUNICATION TERMINALS

Field of the Invention

5 The present invention relates generally to methods for broadcasting messages on a communication network, and more particularly to improved method and apparatus for selectively targeting broadcast messages based upon geographic criteria.

Background of the Invention

10 In a traditional telephone system, a calling party or originator can establish a connection with a called party or recipient. Beyond the basic point-to-point connection provided by the traditional telephone system, modern communication networks that employ digital technology often provide broadcast capability. A message known as a broadcast message can be sent from an originator to a group of
15 intended recipients rather than a single recipient. For example, digitally encoded alphanumeric messages such as news reports or advertisements may be sent as broadcast messages to all mobile communication terminals currently registered with a cellular telephone system.

 By using a network's broadcast capability, an originator needs to send only one
20 message in order to reach a plurality of recipients. Thus, the originator is relieved of the burden of sending a multiplicity of individual messages to the recipients, one by one. Moreover, the use of broadcast messages also relieves the network of the burden of carrying a flurry of messages addressed to individual terminals – a flurry sometimes called a storm – and thereby avoids wasting the network's capacity.

In recognition of these advantages, today's operational standards for modern digital cellular telephone systems such as TIA Standard IS-136 provide broadcast capability. Although broadcast capability is clearly a valuable provision, not all users of a given communication network necessarily have an interest in receiving all broadcast messages sent over that network. For this reason, various ways have evolved for narrowing the list of intended recipients of a broadcast message. One of these ways is to form broadcast groups. A broadcast group might, for example, consist of a community's volunteer firefighters. Firefighters have interest in receiving a certain subset of broadcast messages that are not necessarily relevant to the entire population.

Using broadcast groups, the particular population can be targeted to receive a broadcast message. The intended recipients are identified by a broadcast group code carried by the message. By interpreting the broadcast group code, a communication terminal that receives a broadcast message can determine whether or not to accept that message. By selectively accepting broadcast messages, the communication terminal can shield its user from information clutter that might otherwise result from indiscriminately accepting all broadcast messages. Furthermore, accepting broadcast messages selectively rather than indiscriminately enables portable communication terminals to conserve their battery and processor resources.

The operation of broadcast groups requires that group memberships be managed, which is to say that members need to be added and dropped from various broadcast groups as interests change. Interests can change frequently in the case of a wireless network such as a cellular telephone network, particularly in concert with changes in the users' geographic locations. For example, messages concerning traffic

accidents and congestion, or messages concerning the availability of gasoline and restaurants, have interest only to a group of users that are mobile, transient, and geographically defined. Conversely, the group of users interested in severe-weather alerts changes in response to the track of a storm, even though the users themselves might well be stationary. In either situation, however, broadcast group membership must be managed actively in order to avoid troubling a large body of network users with information that benefits only a few. So, although the introduction of broadcast groups represents a clear step forward in narrowing the intended audience for broadcast messages, the requirement to manage broadcast groups constitutes a significant limitation in the context of groups that have a rapidly changing membership based on geographic considerations.

In response to this limitation, broadcast messages sent by cellular telephone networks can be targeted geographically, although today's methods for doing so are quite limited and imprecise. In the case of IS-136 cellular systems, for example, the digital control channels (DCCs) of each cell carry broadcast traffic. Thus, the reach of a broadcast message can be restricted cell-by-cell, simply by choosing to send the broadcast message or not on a particular DCC. Further, cells are often divided into sectors in order to exploit the properties of directional base-station antennas, thereby opening the possibility of sector-by-sector geographic resolution for broadcast messages.

Nevertheless, a cell or sector has a large coverage area, typically on the order of ten-to-twenty kilometers in radius. Consequently, there remains a need to improve the geographic resolution by which broadcast messages can be targeted to the users of communication networks, particularly to the users of mobile communication networks

such as cellular telephone networks, so that users receive only information that is of concern to them. An improvement in broadcast resolution based on geographic location would open the possibility of finely targeted advertisements and other commercial activities directed toward mobile users, as well as finely targeted reports and alerts concerning topics of a public-interest nature such as traffic accidents or road congestion, man-made or natural disasters of limited geographic import, fire and police actions, restricted-activity areas such as blasting zones, severe weather warnings, and so forth.

10

Summary of the Invention

The present invention improves the geographic resolution by which messages can be targeted to communication terminals, which is particularly important when broadcast messages are sent over a wireless network to a population of mobile users.

According to the present invention, a target area of reception is specified for a message. The target area can be specified, for example, by the radius and center coordinates of a geographic circle. The target area of reception is compared to location data stored in the receiving terminal. When the location stored in the terminal falls within the target area of reception, the communication terminal accepts the messages. Conversely, when the location stored in memory falls outside the target area of reception, the communication terminal does not accept the message.

20

In one embodiment of the invention that is particularly beneficial to users of wireless networks, the current location of a mobile terminal is determined by a positioning receiver such as a global positioning system GPS receiver that is operably connected to the mobile terminal. Logic within the mobile terminal compares the

Figure 6 is a flow diagram showing the operation of the communication terminal upon receipt of a targeted message having the format shown in Figure 3.

Detailed Description of the Invention

5 Referring now to the drawings, a system and method for transmitting geographically targeted messages will be described. The disclosed embodiment is used in a mobile communication system. However, the invention may be used in other types of communication networks, such as wireline networks.

The mobile communication system, which is indicated generally by the
10 numeral 10, comprises a plurality of base stations 12 which are connected via a mobile services switching center (MSC) 14 to a terrestrial communications network such as the Public Switched Telephone Network (PSTN) 16. Each base station 12 is located in and provides service to a geographic region referred to as a cell. In general, there is one base station 12 for each cell within a given network. Within each cell,
15 there may be a plurality of mobile communication terminals 100 that communicate via radio link with the base station 12. The base station 12 allows the user of the mobile communication terminal 100 to communicate with other mobile communication terminals 100, or with users connected to the PSTN 16. The mobile services switching center 14 routes calls to and from the mobile communication terminal 100
20 through the appropriate base station 12. Information concerning the location and activity status of the mobile communication terminal 100 is stored in a database which is connected to the MSC 14 so that the network can route communications to the base station that is currently servicing the mobile communication terminal 100. In this

illustration, the communication network 10 is a digital cellular telephone network such as a network that operates according to TIA Standard IS-136.

A message such as a text message that is to be transmitted to communication terminals 100 in a targeted geographic area is provided by a message source 20. The message source 20 also provides target area data along with the message. The message source 20 may be external to the communication network 10 or may reside within the communications network 10. If the message source resides outside of the communication network 10, the message is passed from the message source 20 to the network gateway 18, which formats the text into a message as described below for transmission over the communication network 10. The message can be formatted at other locations within the network 10. In one embodiment, the message is routed through the network 10 to the appropriate base station(s) 12 serving cells that cover the targeted geographic area. Alternatively, the message can be broadcast throughout the entire network. The targeted geographic area may lie entirely within a cell, or may occupy portions of two or more cells. The targeted message is transmitted by the base station(s) 12 to all mobile communication terminals 100 in the selected cells. All mobile terminals 100 receiving the message will determine whether to accept the message based on the target area data associated with the message.

Figure 2 is a block diagram showing one embodiment of the mobile communication terminal 100. The mobile communication terminal 100 shown in Figure 2 is a fully functional radio transceiver capable of transmitting and receiving digital signals. Those skilled in the art will recognize, however, that the present invention may be implemented in an analog transceiver. The mobile communication terminal 100 includes a control unit or logic unit 102, an operator interface 104, a

transmitter 120, a receiver 140, a memory 150, and a positioning receiver 160, and a position memory 170.

The operator interface 104 includes a display 106, keypad 108, control unit 110 microphone 112, speaker 114, alarm 116, and speech synthesizer 118. The display 106 allows the operator to see dialed digits and call status information. The keypad 108 allows the operator to dial numbers, enter commands, and select options. The control unit 110 interfaces the display 106 and keypad 108 with the control unit 102. The microphone 112 receives audio signals from the user and converts the audio signals to analog signals. Speaker 114 converts analog signals from the receiver 140 to audio signals that can be heard by the user. The alarm 116 produces an audible tone to notify the user in case of receipt of an urgent message. The speech synthesizer 118 converts text messages to an audible signal that can be played back through the speaker 114.

The analog signals from the microphone 112 are applied to the transmitter 120. The transmitter 120 includes an analog-to-digital converter 122, a digital signal processor 124, and a modulator 126. The analog to digital converter 122 changes the analog signals from the microphone 112 into a digital signal. The digital signal is passed to the digital signal processor 124. The digital signal processor 124 compresses the digital signal and inserts error detection, error correction and signaling information. The compressed and encoded signal from the digital signal processor 124 is passed to the modulator 126. The modulator 126 converts the signal to a form that is suitable for transmission on a RF carrier.

The receiver 140 includes a demodulator 142, a digital signal processor 144, and a digital to analog converter 146. Received signals are passed to the demodulator

142 which extracts the transmitted bit sequence from the received signal. The demodulator 142 passes the demodulated signal to the digital signal processor 144 which decodes the signal, corrects channel-induced distortion, and performs error detection and correction. The digital signal processor 144 also separates control and signaling data from speech data. The control and signaling data is passed to the control unit 102. Speech data is processed by a speech decoder and passed to the digital-to-analog converter 146. The digital-to-analog converter 146 converts the speech data into an analog signal which is applied to the speaker 114 to generate audible signals which can be heard by the user.

10 The control unit 102, such as a programmed microprocessor, functions to coordinate the operation of the transmitter 120 and the receiver 140. Memory 150 stores the program instructions and data needed by the control unit 102 to control the communications terminal 100. The functions performed by the control unit 102 include power control, channel selection, timing, as well as a host of other functions.

15 The control unit 102 inserts signaling messages into the transmitted signals and extracts signaling messages from the received signals. The control unit 102 responds to any base station commands contained in the signaling messages, and implements those commands. When the user enters commands via the keypad 108, the commands are transferred to the control unit 102 for action.

20 The positioning receiver 160 receives signals from a space-based or land-based station that transmits positioning data. For example, the positioning receiver 160 could be a GPS receiver. The received data is passed to the control unit 102 which uses the information to calculate the geographic location of the communication terminal 100. The location is then stored in the position memory 170. The position

memory 170 can be an operational register within the control unit 102 or an address space in memory 150. The position memory 170 could also be a separate RAM or ROM memory.

Referring now to Figures 3 – 6, the method for transmitting and receiving geographically targeted messages to communication terminals 100 will be described. Figure 3 shows the format of a targeted message 200 that includes the text provided by the message source 20. The message 200 comprises a transmission header 205, a message field 210, and a trailer 215. The transmission header 205 includes a From Address field 220, which identifies the message source 20, a To Address field 225, which identifies the communication terminal 100 intended to receive a message 200 that is addressed individually rather than broadcast, a Broadcast Indicator field 230, which marks the message 200 as a broadcast or non-broadcast message, a Broadcast Group Code field 235, which identifies a broadcast group intended to receive a broadcast message, a Target Indicator field 240, which marks the message 200 as containing a target area of reception or not, and a Target Area of Reception field 250, which specifies a geographic area for which the message 200 has relevance. The Target Area of Reception field 250 includes a Center field 252, which specifies the latitude and longitude of the center of a circular geographic area, and a Radius field 254, which specifies the radius of the circular geographic area.

The particular choice and arrangement of fields described in the context of Figure 3 illustrate one possible embodiment and is not intended to be limiting. Those skilled in the art will realize that the invention can be carried out with other choices and arrangements of the same or similar fields. In particular, the To Address field 225 can be re-used as the Broadcast Group Code field 235, with the contents of the field

differentiated by setting the value of the Broadcast Indicator field 230. Moreover, the Target Area of Reception field 250 can be described in a number of other ways, for example by defining the vertices or edges of a geographic polygon, or by specifying the center of the target area of reception and using a pre-agreed value for its radius, or
5 by specifying its size and using a default center, or by specifying the longitude and latitude of the boundaries of a region, and the like.

Figure 4 is an illustration of the location data 290 which is stored in the position memory 170. The location data represents a reference location used for comparison to the targeted geographic area. The location data includes a latitude field
10 292 and a longitude field 294 or fields for carrying equivalent information for other geometric forms. Normally, the reference location will be the geographic location of the communication terminal 100 itself. However, if it is desired to monitor messages directed to a location remote from the communication terminal 100, location data for the remote location can be loaded into this field. In the preferred embodiment, the
15 location data 290 is determined by the positioning receiver 160 and loaded into the position memory 170 as previously described. Alternatively, the location data 290 can be loaded manually into the position memory 170 through the keypad 108 or entered automatically into the position memory 170 over a communication link provided by the receiver 120. The later two embodiments are particularly useful to define a
20 reference location other than the current location of the communication terminal 100, and also to extend the usefulness of the invention to encompass communication terminals 100 that lack a positioning receiver 160, for example cellemetry equipment, computers equipped with wireline modems, and so forth.

Figure 5 illustrates a method for constructing the targeted message 200 shown in Figure 3. At the top of Figure 5, the message source 20 transfers a text message, such as a road-congestion alert, to be placed in the message field 210 of the message 200, together with ancillary information needed to construct the other fields of the message 200 (step 300). The message can be formatted at any location in the network, such as the gateway 18 or the MSC 14. When the message 200 is to be broadcast rather than addressed individually, the ancillary information specifies the contents of the Broadcast Group Code field 235. When the message is to be addressed individually rather than broadcast, the ancillary information specifies the contents of the To Address field 225. When the message is to be targeted geographically, the ancillary information specifies the contents of the Target Area of Reception field 250.

When the message 200 is to be individually addressed rather than broadcast, the Broadcast Indicator field 230 of the message 200 is set to binary zero (step 310). When the message 200 is to be broadcast rather than individually addressed, the Broadcast Indicator field 230 of the message 200 is set to binary one (step 320). When the message is not geographically targeted, i.e., the ancillary information does not include information to be loaded into the Target Area of Reception field 250 of the message 200, the Target Indicator field 240 of the message 200 is set to binary zero (step 330). When the message is geographically targeted, the Target Indicator field 240 of the message 200 is set to binary one (step 340).

The message 200 is then constructed according to the format of Figure 3 by loading the ancillary data into the appropriate message fields shown in Figure 3 (block 350). When the broadcast flag 230 is on (i.e., Broadcast Indicator field is set to "1"),

information regarding the intended broadcast group is loaded into the Broadcast Group Code field 235 of the message 200. When the broadcast flag 230 is off (i.e., Broadcast Indicator field is set to "0"), information regarding an individual address is loaded into the To Address field 225 of the message 200. When the target flag 240 is on (i.e., Target Indicator field is set to "1"), information regarding the target area of reception is loaded into the Target Area of Reception field 250 of the message 200. When the target flag 240 is off (i.e., Target Indicator field is set to "0"), the Target Area of Reception field 250 of the message 200 is left blank. The remainder of the message 200 is conventionally constructed (step 360) according to the formats and protocols of the communication network 100 employed, and the message 200 is passed to the base station 12 for transmission to the communication terminal 100 (step 370). The next message transfer is awaited (step 380).

Figure 6 illustrates the procedure for handling messages received by the communication terminal 100. The message 200 is received, demodulated and decoded by the receiver 120, and then passed to the control unit 102 for processing (step 400). The control unit 102 initially examines the Broadcast Indicator field 230 of the message 200 (step 405) to determine whether the message is a broadcast message. When the broadcast flag 230 is on, the control unit 102 compares the contents of the Broadcast Group Code field 235 to a list of broadcast group codes held in the memory 150, in order to determine whether the communication terminal 100 has membership in the specified broadcast group (step 410). If the communication terminal 100 is not a member of the specified broadcast group, the control unit 102 instructs the communication terminal 100 to await the arrival of the next message (step 450) and ceases processing of the current message. If the communication

terminal 100 is a member in the indicated broadcast group, the control unit 102 examines the Target Indicator field 240 (step 420).

When the target flag 240 is off, the control unit 102 instructs the communication terminal 100 to process the message 200 conventionally (step 425),
5 and then to await the arrival of the next message (step 450). When the target flag 240 is on, the control unit 102 queries the position memory 170 to obtain the location data 290 (step 430). The control unit 102 then compares the location data 290 to the contents of Target Area of Reception field 250 to determine whether the reference location falls within the targeted geographic region (step 435). The targeted
10 geographic region is defined by the contents of the Target Area of Reception field 250. If not, the control unit 102 instructs the communication terminal 100 to disregard the message 200 (step 440) and the communication terminal 100 awaits the arrival of the next message (step 450).

If the reference location falls within the geographic area specified by the
15 Target Area of Reception field 250, the control unit 102 instructs the communication terminal 100 to process the message 200 as described below (step 445). The communication terminal 100 then awaits the arrival of the next message (step 450).

When the broadcast flag 230 is found to be off in step 405, the control unit 102 examines the contents of the To Address field 225 of the message 200 (step 415). If
20 the message 200 is not addressed to the communication terminal 100, the communication terminal 100 awaits the arrival of the next message (step 450) rather than to consider the current message any further. If the message 200 is addressed to the communication terminal 100, the control unit 102 examines the Target Indicator field 240 and proceeds as described above (step 420).

Processing the message 200 in step 445 means any action taken by the mobile terminal in response to the received message 200. For example, processing the message may comprise displaying the text of the message 200 on the display 106, transducing the text of the message 200 to audible form by use of the speech synthesizer 118 and playing the result on the speaker 114, announcing the arrival of the message 200 by the audio alarm 116, storing the message 200 in the memory 150 for later use, and the like. Also, those skilled in the art will recognize that the targeted message may comprise a signaling message used for network management and that the processing of the message 200 can occur without user knowledge.

By accepting and processing the message 200 only selectively, based on comparing geographic information carried by the Target Area of Reception field 250 with the terminal location data 290, rather than accepting and processing all incoming messages indiscriminately, the present invention improves the geographic resolution by which messages can be targeted to communication terminals 100, which is particularly important when broadcast messages are sent over a wireless network to a population of mobile users.

Although the present invention has been described in connection with a digital cellular telephone network filling the role of the communication network, the invention is not limited to such use, and applies to all kinds of communication networks, both wireline and wireless, including, but not limited to, communication networks such as satellites networks, private radio networks such as those used by police organizations, wide-area and metropolitan-area telecommunication networks such as wireline digital telephone networks with data communication capabilities, local-area networks, private corporate networks, and the like. The communication

terminals can be radio transceivers with digital message capability, personal computers or personal digital assistants equipped with wireline or wireless modems, ISDN adapters, DSU/CSU adapters, and the like. In the later instances, the communications terminal 100 would, of course, be replaced by a modem having the

5 characteristics needed by the particular choice of communication network.

Additionally, the invention may be carried out in specific ways other than those set forth herein without departing from the spirit and the essential characteristics of the present invention. Consequently, the present embodiments are to be construed in all aspects as illustrative and not restrictive. All changes coming within the meaning and

10 equivalence range of the appended claims are intended to be embraced by these claims.

I claim:

1. A method for transmitting a targeted message from a transmitting terminal to a receiving terminal comprising:
 - 5 transmitting from a transmitting station a message and associated target area data that specifies a targeted geographic area for the message;
 - receiving the message and corresponding target area data at a receiving terminal;
 - establishing a reference location;
 - 10 determining whether the reference location is within said targeted geographic area based on said target area data; and
 - processing the message if the reference location is within said targeted geographic area.
- 15 2. The method of claim 1 further including storing location data representing the reference location in a memory at said receiving terminal.
3. The method of claim 2 wherein the location data is input manually into said receiving terminal.
- 20 4. The method of claim 2 wherein the location data is determined based on data from a positioning receiver operatively connected to the receiving terminal.

5. The method of claim 2 wherein the location data is transmitted to said receiving terminal from a remote location.

6. The method of claim 2 wherein the reference location is the location of the receiving terminal.

7. The method of claim 2 wherein the reference location is a location remote from the receiving terminal.

8. The method of claim 2 wherein the determining step includes storing location data at said receiving station and comparing said location data with said target area data.

9. A communication terminal for selectively receiving a transmitted message comprising:

a receiver for receiving a transmitted message and associated target area data that specifies a targeted geographic area for the message;

a memory for storing location data representing a reference location;

a control unit for determining whether the reference location is in said targeted geographic area based on said target area data and processing said message based on the outcome of said determination.

10. The communication terminal of claim 9 further including input means for inputting said location data.

11. The communication terminal of claim 10 wherein input means comprises
5 a positioning receiver operatively connected to said control unit.

12. The communication terminal of claim 11 wherein the positioning receiver is a global positioning system receiver operatively connected to said control unit.

10 13. The communication terminal of claim 10 wherein the input means comprises a keypad operatively connected to said control unit.

14. The communication terminal of claim 9 wherein the location data is received from a remote location via said receiver.

15

15. A communication system for transmitting geographically targeted messages comprising:

a. a transmitting terminal for transmitting a targeted message and associated target area data;

20 b. at least one receiving terminal for receiving the targeted message and said target area data transmitted from said transmitting terminal; and

c. control means associated with said receiving terminal for determining whether to accept the targeted message based on said target area data.

16. The communication system of claim 15 wherein said receiving terminal includes a memory for storing location data representing a reference location for use by said control unit to determine whether the communication terminal is in said targeted geographic area.

5

17. The communication system of claim 15 wherein said receiving terminal includes input means for inputting said location data.

18. The communication system of claim 17 wherein the input means
10 comprises a positioning receiver operatively connected to said receiving terminal.

19. The communication system of claim 18 wherein the positioning receiver is a global positioning system receiver operatively connected to said control unit.

15 20. The communication system of claim 17 wherein the input means comprises a keypad operatively connected to said control unit.

21. The communication system of claim 16 wherein the location data is received at said receiving terminal from a remote location.

20

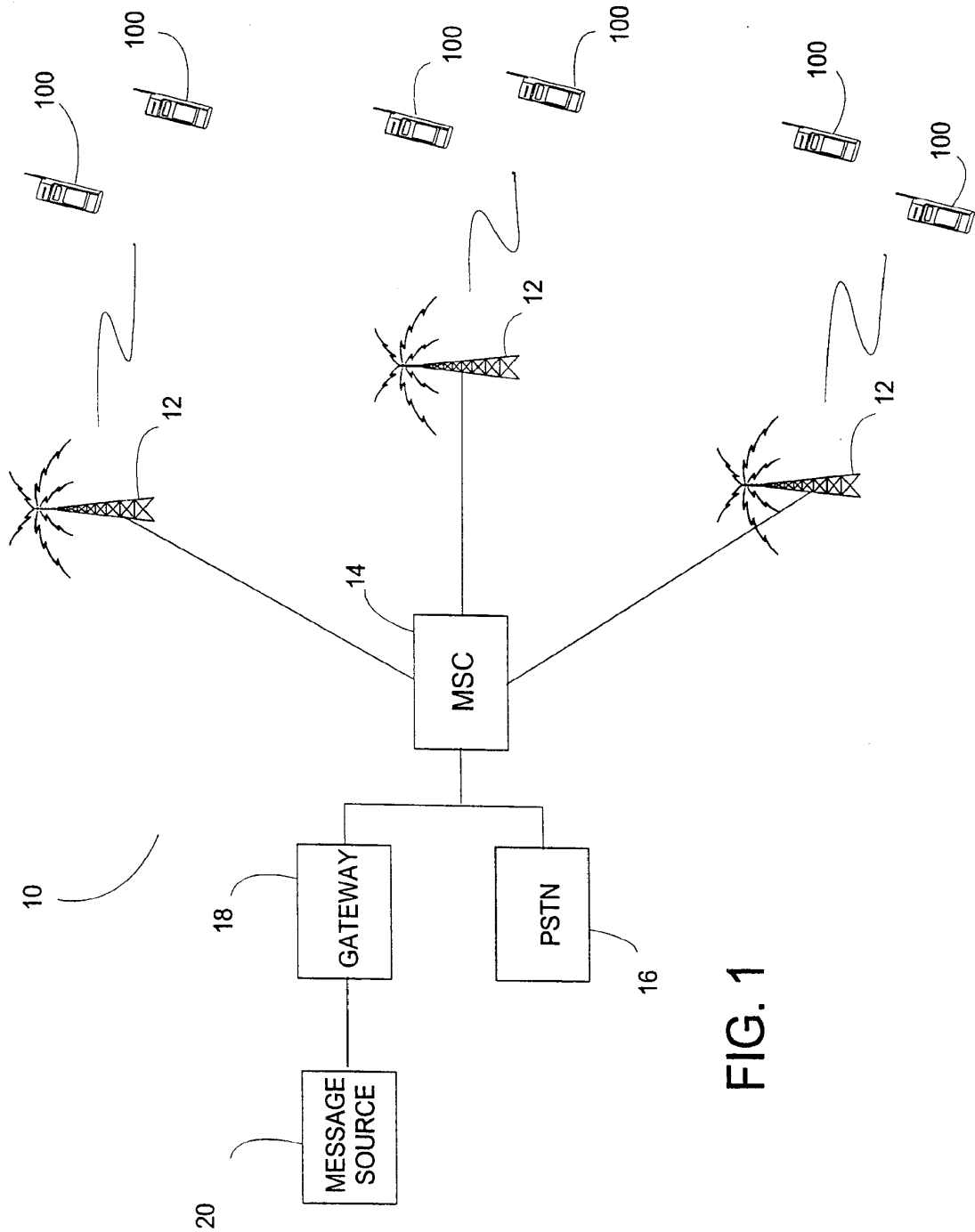

FIG. 1

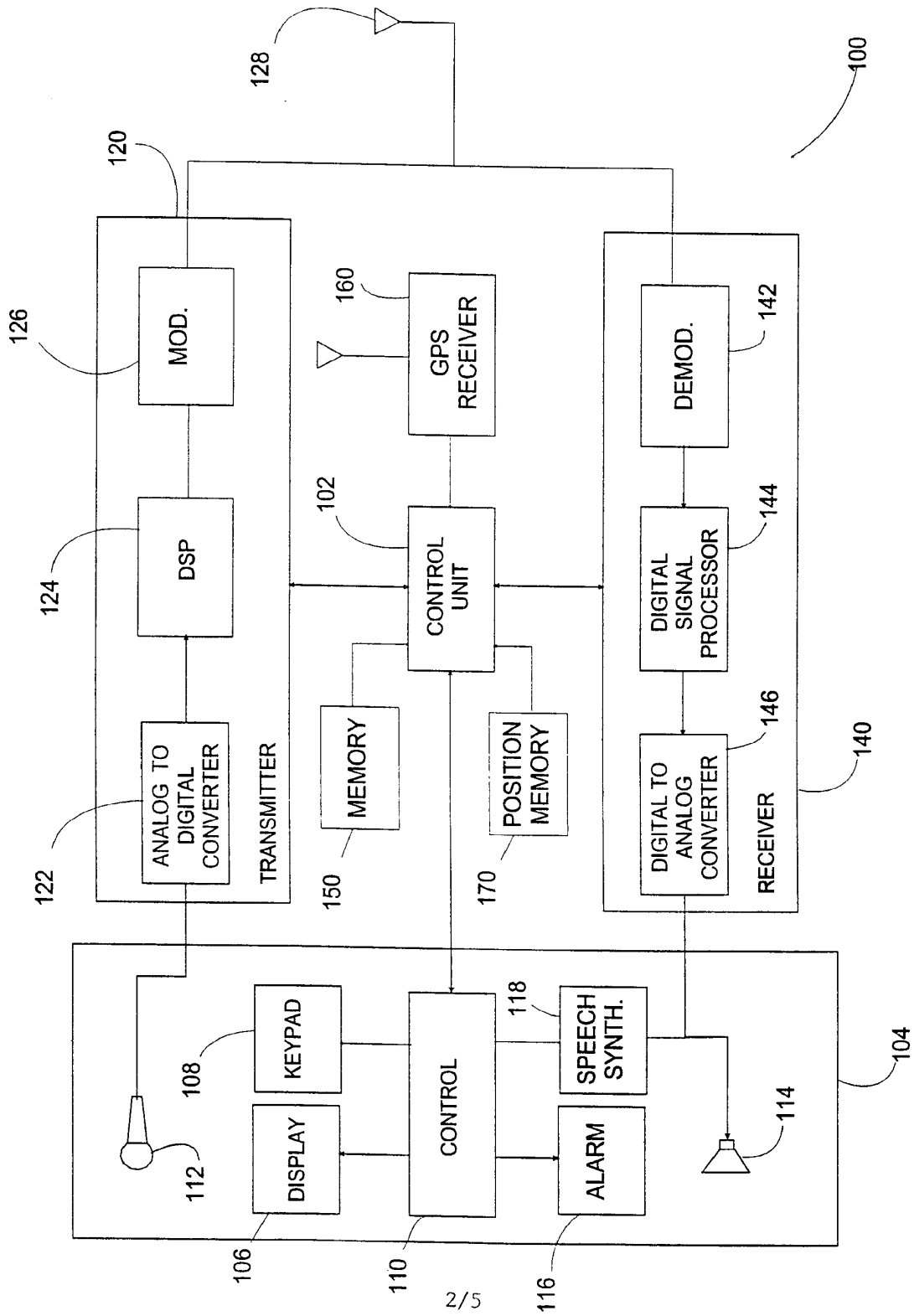

FIG. 2

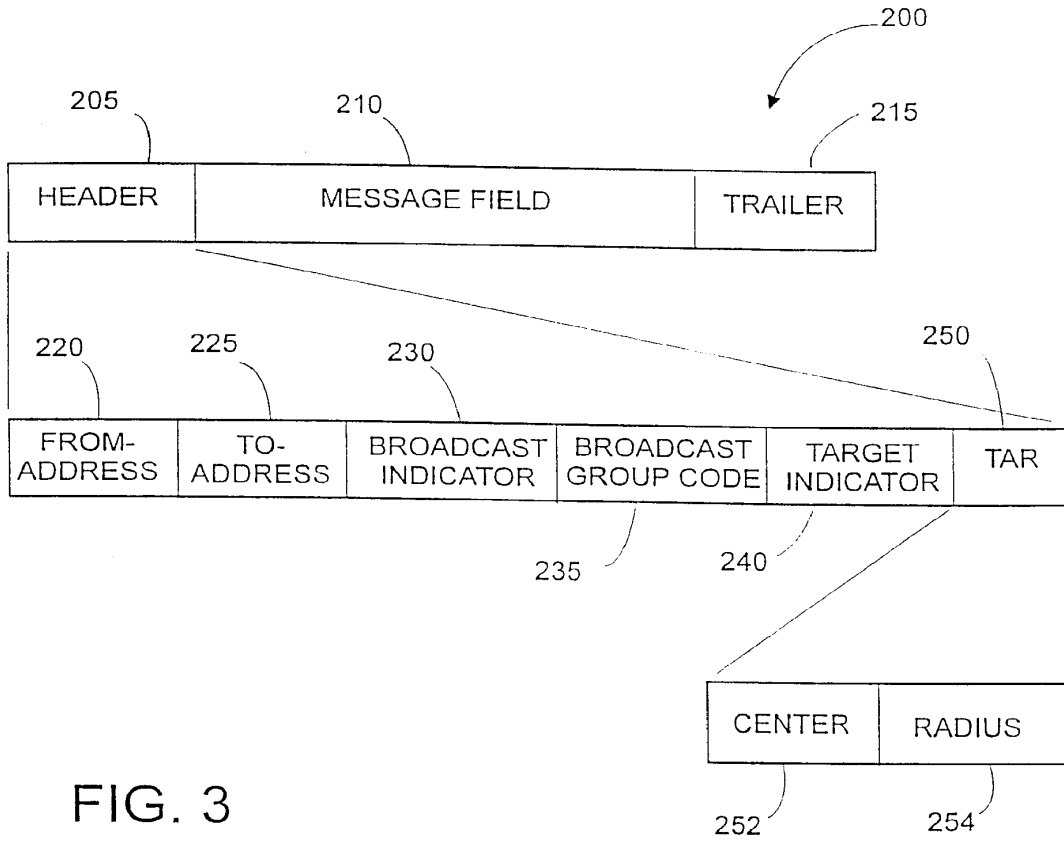

FIG. 3

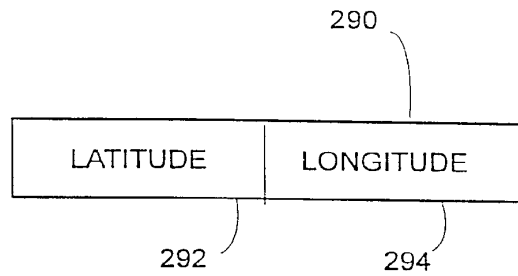

FIG. 4

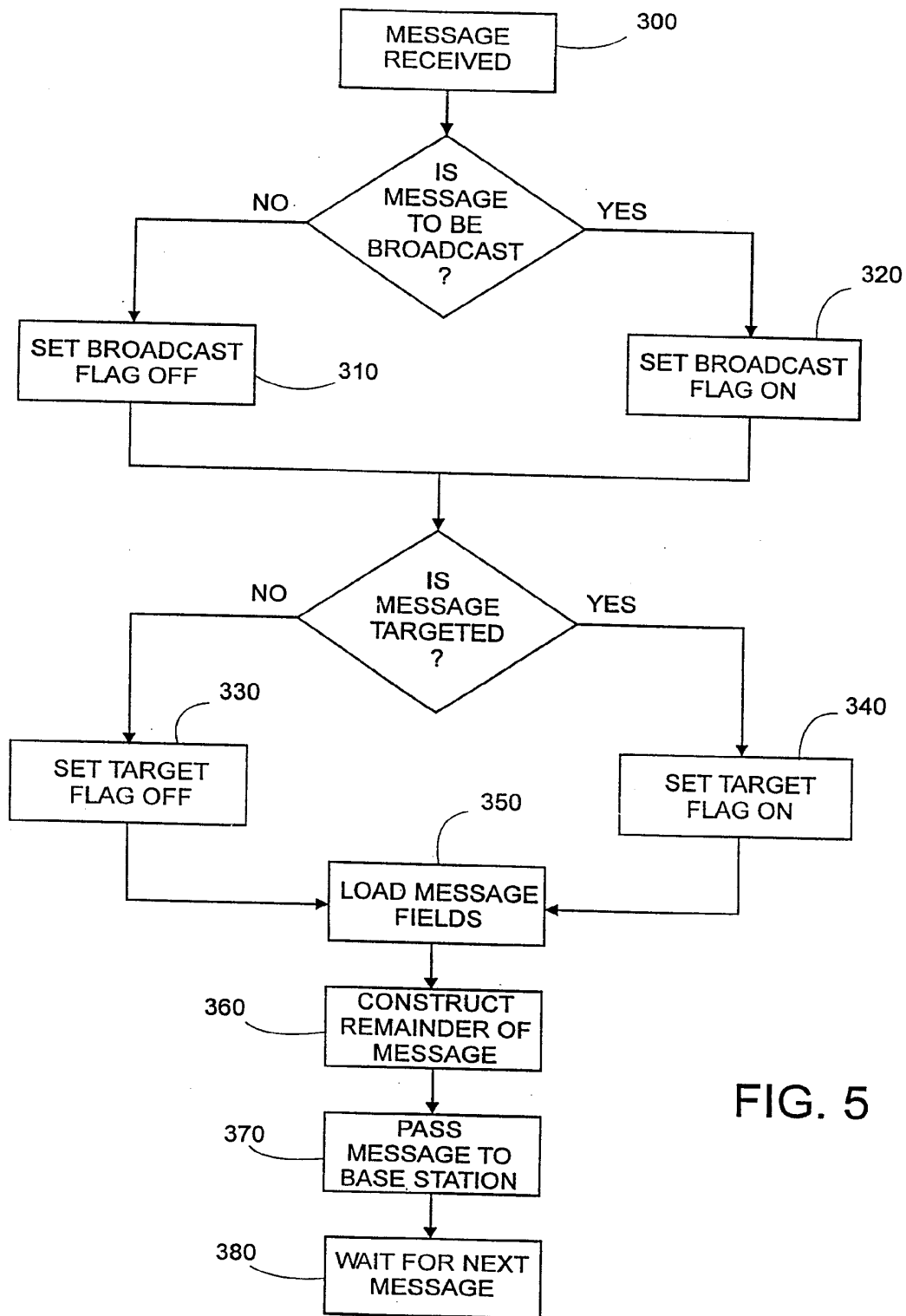
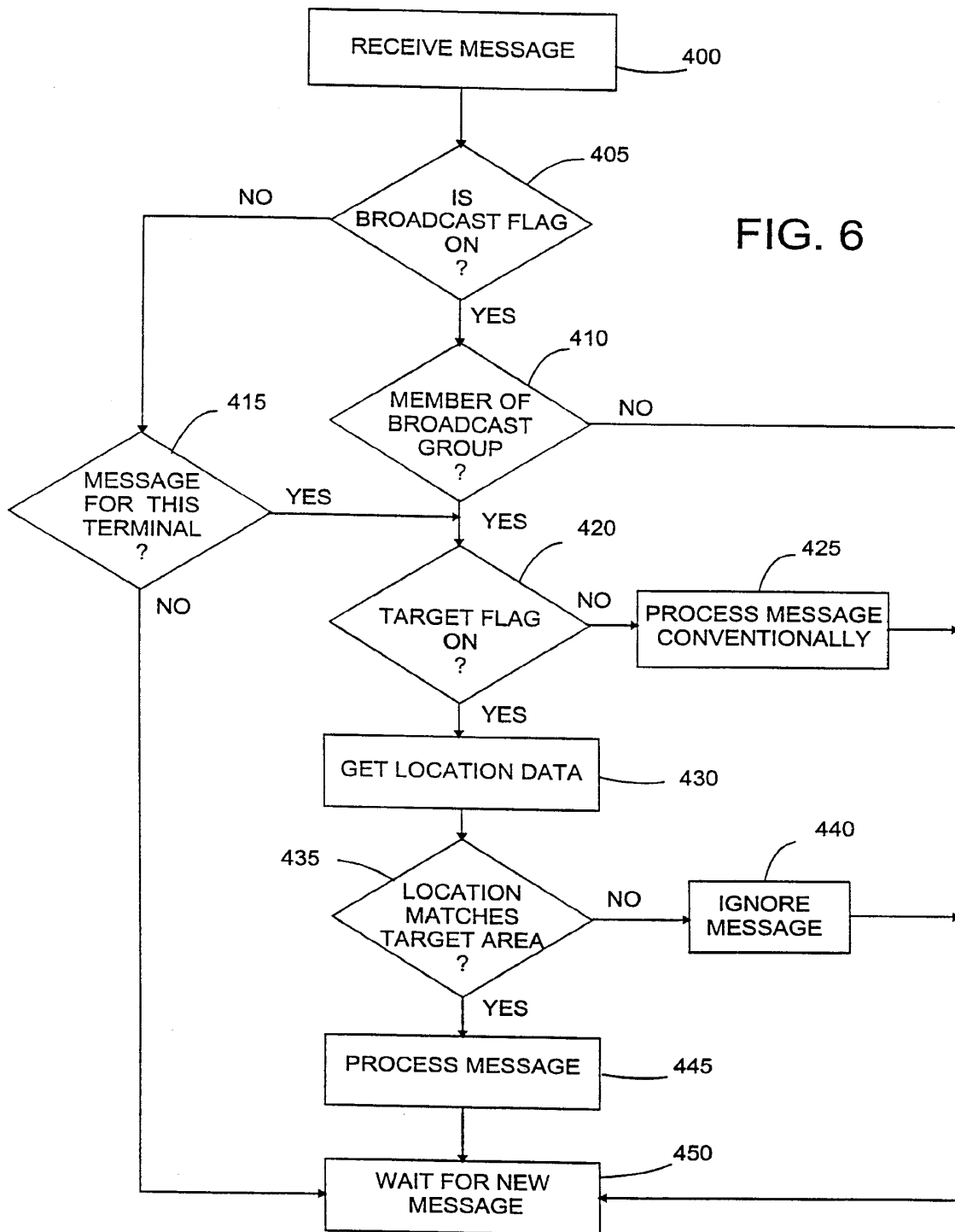

FIG. 5



INTERNATIONAL SEARCH REPORT

International Application No
PCT/US 99/26045

A. CLASSIFICATION OF SUBJECT MATTER IPC 7 H04Q/22				
According to International Patent Classification (IPC) or to both national classification and IPC				
B. FIELDS SEARCHED				
Minimum documentation searched (classification system followed by classification symbols) IPC 7 H04Q				
Documentation searched other than minimum documentation to the extent that such documents are included in the fields searched				
Electronic data base consulted during the international search (name of data base and, where practical, search terms used)				
C. DOCUMENTS CONSIDERED TO BE RELEVANT				
Category *	Citation of document, with indication, where appropriate, of the relevant passages	Relevant to claim No.		
X	WO 96 05678 A (MITRE CORP) 22 February 1996 (1996-02-22) page 5, line 2 - line 12 page 9, line 13 - line 21 page 6, line 15 - line 20 page 7, line 19 - page 8, line 6 -----	1-4, 6-13, 15-20		
X	DE 196 05 632 A (AEG MOBILE COMMUNICATION) 21 August 1997 (1997-08-21) page 2, line 24 - line 26 page 2, line 51 - line 56 page 3, line 23 - line 28 page 3, line 66 - page 4, line 14 -----	1, 2, 4-6, 8, 9, 11, 12, 14-16, 18, 19, 21		
<input type="checkbox"/> Further documents are listed in the continuation of box C. <input checked="" type="checkbox"/> Patent family members are listed in annex.				
* Special categories of cited documents:				
<table style="width: 100%; border: none;"> <tr> <td style="width: 50%; border: none; vertical-align: top;"> *A* document defining the general state of the art which is not considered to be of particular relevance *E* earlier document but published on or after the international filing date *L* document which may throw doubts on priority claim(s) or which is cited to establish the publication date of another citation or other special reason (as specified) *O* document referring to an oral disclosure, use, exhibition or other means *P* document published prior to the international filing date but later than the priority date claimed </td> <td style="width: 50%; border: none; vertical-align: top;"> *T* later document published after the international filing date or priority date and not in conflict with the application but cited to understand the principle or theory underlying the invention *X* document of particular relevance; the claimed invention cannot be considered novel or cannot be considered to involve an inventive step when the document is taken alone *Y* document of particular relevance; the claimed invention cannot be considered to involve an inventive step when the document is combined with one or more other such documents, such combination being obvious to a person skilled in the art. *&* document member of the same patent family </td> </tr> </table>			*A* document defining the general state of the art which is not considered to be of particular relevance *E* earlier document but published on or after the international filing date *L* document which may throw doubts on priority claim(s) or which is cited to establish the publication date of another citation or other special reason (as specified) *O* document referring to an oral disclosure, use, exhibition or other means *P* document published prior to the international filing date but later than the priority date claimed	*T* later document published after the international filing date or priority date and not in conflict with the application but cited to understand the principle or theory underlying the invention *X* document of particular relevance; the claimed invention cannot be considered novel or cannot be considered to involve an inventive step when the document is taken alone *Y* document of particular relevance; the claimed invention cannot be considered to involve an inventive step when the document is combined with one or more other such documents, such combination being obvious to a person skilled in the art. *&* document member of the same patent family
A document defining the general state of the art which is not considered to be of particular relevance *E* earlier document but published on or after the international filing date *L* document which may throw doubts on priority claim(s) or which is cited to establish the publication date of another citation or other special reason (as specified) *O* document referring to an oral disclosure, use, exhibition or other means *P* document published prior to the international filing date but later than the priority date claimed	*T* later document published after the international filing date or priority date and not in conflict with the application but cited to understand the principle or theory underlying the invention *X* document of particular relevance; the claimed invention cannot be considered novel or cannot be considered to involve an inventive step when the document is taken alone *Y* document of particular relevance; the claimed invention cannot be considered to involve an inventive step when the document is combined with one or more other such documents, such combination being obvious to a person skilled in the art. *&* document member of the same patent family			
Date of the actual completion of the international search		Date of mailing of the international search report		
22 February 2000		02/03/2000		
Name and mailing address of the ISA		Authorized officer		
European Patent Office, P.B. 5818 Patentlaan 2 NL - 2280 HV Rijswijk Tel. (+31-70) 340-2040, Tx. 31 651 epo nl, Fax: (+31-70) 340-3018		Kampouris, A		

Form PCT/ISA/210 (second sheet) (July 1992)

INTERNATIONAL SEARCH REPORT

Information on patent family members

International Application No PCT/US 99/26045
--

Patent document cited in search report	Publication date	Patent family member(s)	Publication date
WO 9605678 A	22-02-1996	US 5636245 A CA 2197080 A EP 0775407 A FI 970512 A JP 10504392 T NO 970578 A	03-06-1997 22-02-1996 28-05-1997 07-02-1997 28-04-1998 24-03-1997
DE 19605632 A	21-08-1997	EP 0790747 A NO 970724 A	20-08-1997 18-08-1997

Form PCT/ISA/210 (patent family annex) (July 1992)

PCT

WORLD INTELLECTUAL PROPERTY
International Bureau

EVIT 9834-9839
Master file copy

INTERNATIONAL APPLICATION PUBLISHED UNDER



<p>(51) International Patent Classification⁶ : H04L 27/00, G08G 1/23</p>	<p>A1</p>	<p>(11) Int. WO 9605678A1 (43) International Publication Date: 22 February 1996 (22.02.96)</p>
<p>(21) International Application Number: PCT/US95/10170 (22) International Filing Date: 10 August 1995 (10.08.95) (30) Priority Data: 288,040 10 August 1994 (10.08.94) US (71) Applicant: THE MITRE CORPORATION [US/US]; 202 Burlington Road, Bedford, MA 01730-1420 (US). (72) Inventors: ERNST, Darrell, E.; 8720 Chipita Park Road, Chipita Park, CO 80809 (US). MCMILLAN, Donald, R.; 6220 Moorfield Avenue, Colorado Springs, CO 80919 (US). FOLK, Thomas, L.; 618 Southern Cross Drive, Colorado Springs, CO 80906 (US). ROGERS, Steven, R.; 5510 Broadmore Bluffs Drive, Colorado Springs, CO 80906 (US). (74) Agents: HUNT, Ross, F., Jr. et al.; Larson and Taylor, 727 23rd Street, South, Arlington, VA 22202 (US).</p>	<p>(81) Designated States: CA, FI, JP, KR, MX, NO, SG, European patent (AT, BE, CH, DE, DK, ES, FR, GB, GR, IE, IT, LU, MC, NL, PT, SE). Published With international search report. Before the expiration of the time limit for amending the claims and to be republished in the event of the receipt of amendments.</p>	

(54) Title: LOCATION BASED SELECTIVE DISTRIBUTION OF GENERALLY BROADCAST INFORMATION

(57) Abstract

A system for determining whether information broadcast by a general transmitter is relevant to a particular user based on the location, velocity and/or time of an object of interest includes a remote terminal (110), a general broadcasting unit (200), a transmitter (190) at the general broadcasting unit for broadcasting messages including a segment comprising a region, a velocity and/or a time corresponding to an event, as well as an event specific tag, and storage (130) for storing selection criteria including current position, time and/or velocity information of the use and/or manually entered data of interest. The selection criteria may also include event specific tags. The receiver (120) at the remote terminal (110) receives the messages from the transmitter (190) at the general broadcasting unit (200). A navigational receiver (121) may also be used to acquire navigational information from an appropriate external source. A matching processor (140) at the remote terminal (110) evaluates the segment in the messages, determines if the segment sufficiently matched the stored election criteria and outputs a match signal. A processor (150) in the remote unit (110) receives the match signal, and processes and disseminates the message in accordance with the match signal.

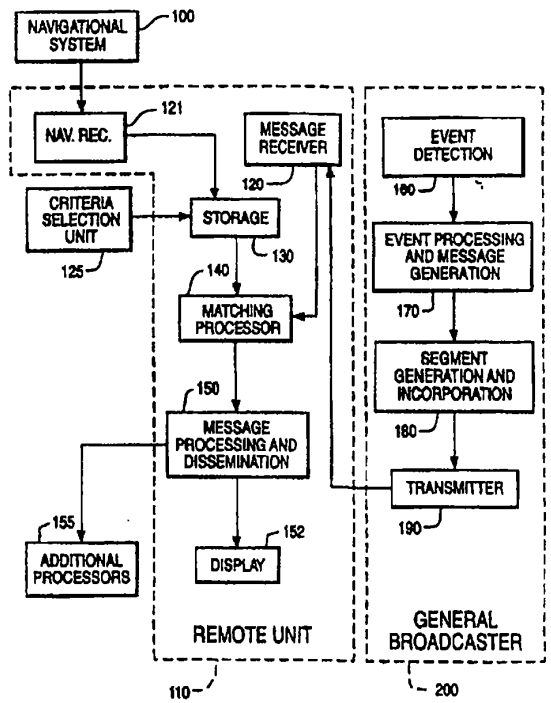

FOR THE PURPOSES OF INFORMATION ONLY

Codes used to identify States party to the PCT on the front pages of pamphlets publishing international applications under the PCT.

AT	Austria	GB	United Kingdom	MR	Mauritania
AU	Australia	GE	Georgia	MW	Malawi
BB	Barbados	GN	Guinea	NE	Niger
BE	Belgium	GR	Greece	NL	Netherlands
BF	Burkina Faso	HU	Hungary	NO	Norway
BG	Bulgaria	IE	Ireland	NZ	New Zealand
BJ	Benin	IT	Italy	PL	Poland
BR	Brazil	JP	Japan	PT	Portugal
BY	Belarus	KE	Kenya	RO	Romania
CA	Canada	KG	Kyrgystan	RU	Russian Federation
CF	Central African Republic	KP	Democratic People's Republic of Korea	SD	Sudan
CG	Congo	KR	Republic of Korea	SE	Sweden
CH	Switzerland	KZ	Kazakhstan	SI	Slovenia
CI	Côte d'Ivoire	LI	Liechtenstein	SK	Slovakia
CM	Cameroon	LK	Sri Lanka	SN	Senegal
CN	China	LU	Luxembourg	TD	Chad
CS	Czechoslovakia	LV	Latvia	TG	Togo
CZ	Czech Republic	MC	Monaco	TJ	Tajikistan
DE	Germany	MD	Republic of Moldova	TT	Trinidad and Tobago
DK	Denmark	MG	Madagascar	UA	Ukraine
ES	Spain	ML	Mali	US	United States of America
FI	Finland	MN	Mongolia	UZ	Uzbekistan
FR	France			VN	Viet Nam
GA	Gabon				

LOCATION BASED SELECTIVE DISTRIBUTION
OF GENERALLY BROADCAST INFORMATION

Background of the Invention

5 Currently, region-specific information is disseminated by predetermined point-to-point communication or by general broadcast which must be manually monitored in order to extract information peculiar to a position, velocity and time of interest.

10 For example, marine weather data is continuously broadcast. However, mariners must monitor the broadcast for long periods of time in order to obtain the information peculiar to their region. Even then, the exact region affected may require computation or

15 may be ambiguously defined. There is also the possibility that the user may miss information of interest because he or she occupies an unknown location, is unfamiliar with the region, or uses a different frame of reference, among other reasons.

20 Another example is tactical ballistic missile (TBM) warning, which is derived from space and ground based sensor data, and is provided through a variety of broadcast and general purpose communications systems to a small subset of in-theater forces.

25 Currently, such warning requires transportable processing stations that can generate information about specific situations in the field but cannot

directly communicate with all individuals affected. The timeliness, reliability, and dispersion of information under these conditions are of concern. Because warning is in the form of geographical
5 coordinates and time of predicted impact, users must interpret the data to determine if the warning affects them.

Some current commercial systems are using GPS information to select relevant data from computer
10 based files such as appropriate electronically stored maps for use in automobiles. These are useful for relatively static information but fail to address dynamic environmental or combat factors.

U.S. Patent No. 5,243,652 to Teare et al.
15 discloses a database access system in which each mobile user has a positioning system which transmits position information to a central facility. This central facility then grants or denies database access depending on the geographical location of the mobile
20 user.

U.S. Patent No. 4,860,352 to Laurance et al. discloses a system in which a satellite system determines the position of a transmitter at a first location and a receiver at a second location. The
25 transmitter position is appended to the received message which is sent by the satellite system to the

receiver. The receiver receives the appended message,
extracts the transmitter position data and compares
the extracted transmitter position with a stored
transmitter position. If the positions correlate, the
5 receiver knows it has received an authentic message.

None of these devices allow for automated
receiver discrimination of any message broadcast
generally in order to only disseminate relevant
messages.

10 Summary of the Invention

It is therefore an object of the present
invention to provide a system which is capable of
determining whether information broadcast by a general
(whether global, regional or local) transmitter is
15 relevant to a particular user based on the location,
velocity and/or position of an object of interest.

In accordance with the present invention, these
and other objects are achieved by providing a
communication system including a remote terminal, a
20 general broadcasting unit, a transmitter at the
general broadcasting unit for broadcasting messages
including a segment comprising a region, a velocity
and/or a time, a receiver at the remote terminal for
receiving messages from the transmitter, and a storage
25 for storing data selection criteria. A navigational

receiver may receive current position, velocity, and/or time information for that remote terminal to be stored as data selection criteria. Data selection criteria may also be manually entered into the storage. The segment may further include an event specific tag. Event specific tags may be stored in the storage in response to manual input and/or be predetermined and stored in the matching processor. A matching processor at the remote terminal evaluates the segment in the messages, determines if the stored data selection criteria satisfies a match condition to the segment, and outputs a match signal. A message processor in the remote unit receives the match signal, and, when the match signal indicates it is appropriate for the remote unit to receive the message, processes and disseminates the message in accordance with the match signal.

Other objects, features and advantages of the invention will be apparent from the following description of the preferred embodiments.

Brief Description of the Drawing

The invention will be described below in further detail with reference to the accompanying drawings wherein Fig. 1 is a block diagram of a system according to the present invention.

Detailed Description of the Invention

The present invention is directed to a system which determines whether access to particular information transmitted by a broadcaster is appropriate for a particular unit remote from the broadcaster. The invention is particularly useful for implementing an addressing distribution system of situation awareness information. The present invention can use satellite provided services, such as the Global Positioning System (GPS), to acquire data and establish user relevance based on current location in real time.

Situation awareness encompasses timely understanding of factors within the operational environment which might affect the manner in which the user proceeds. Some specific examples of functions that could be supported are: 1) warning user of impending tactical ballistic missile (TBM) attack, 2) informing combatant of local friend/foe unit positions, 3) advising user on occurrence of Nuclear/Biological/Chemical (NBC) events, 4) disseminating terrestrial conditions such as impassable mud, flood, fire or snowpack, 5) alerting police unit of nearby robbery in progress, 6) advising users (e.g., mariners) of severe weather conditions, 7) providing pilots with airport information, and 8) supplying

motorists with information such as location of other vehicles in motion, accidents, areas under repair or blocked, etc. Information might also include appropriate situation-specific actions the user might
5 take.

This capability can be implemented on any hardware platform that interfaces with a global positioning or navigation system or other positioning/navigational inputs, and provides world-
10 wide communications connectivity with the sources of the situation alert bulletins. Remote units that receive, process, and display or operate on the situation awareness information can be mobile, transportable, or stationary.

15 The system of the present invention is shown in Figure 1. The navigational system 100 may be, for example, Loran or GPS, or any other source of navigational information, e.g., position, velocity or time. The present invention may operate with either
20 periodic or continuous information delivery systems.

The general broadcaster 200 may include an event detection unit 160 which detects an event. Examples of events to be detected with a suitable detection unit 160 include weather, enemy activity, criminal
25 activity. Detection unit 160 may detect the event directly itself or may receive a detection signal from

an external source. Once detection unit 160 detects an event, it outputs information to an event processing and message generation unit 170. Message unit 170 outputs a message generated in response to the event detection output of detection unit 160 to a segment generation and incorporation unit 180. Incorporation unit 180 then defines a position, a velocity and a time of effectiveness for a particular message based, e.g., on a projected history of the event, and incorporates this information as a segment in the message. For time critical applications, the time of effectiveness may be set to the same universal clock unit used in positioning system 100. The segment may also advantageously include an event specific tag which indicates the type of event detected. This segment may be, for example, a header or a footer on the message. The message containing the segment is then transmitted by a transmitter 190.

The remote unit 110 includes a navigational receiver 121 for receiving various information including navigational information from navigating system 100. A storage unit 130 stores position, velocity and/or time information acquired from navigating system 100 by navigational receiver 121 and/or other selection criteria inputs from manual input unit 125. The selection criteria input may

include other positions, velocities and/or times to increase the amount of information disseminated, as well as event specific tags to customize and reduce the amount of information disseminated. This information provides the basis for defining matching conditions of interest to the user of remote unit 110. It will be appreciated that there may be a plurality of remote units 110, all receiving information from positioning system 100 and broadcaster 200.

Receiver 120 receives messages transmitted by broadcaster 200. It should be noted that for some applications, the navigation system 100 may serve as the general broadcaster. In this case, the navigational receiver 121 serves as the message receiver. Receiver 120 then outputs this message to a matching processor 140. Matching processor 140 compares the information contained in the segment of the message to the information stored in storage 130. If the stored position, velocity and/or time information are within matching conditions of the position, velocity and/or time information for the segment of the transmitted message, then the message processing and dissemination unit 150 will process and disseminate the information in the message. The matching conditions typically consist of an appropriate position and time window such that exact

correlation is not required. Further, information at other regions of interest may be processed by storing additional times, velocities and/or positions, e.g., time, velocity and/or position information based on a projected trajectory of remote unit 110 or based on other remote unit of interest. Additionally, matching processor 140 may compare any event specific tags included in the segment with any event specific tags either stored or matching processor 140 and/or input at criteria selection unit 125 and only allow messages having appropriate event specific tags to be processed and disseminated by unit 150.

Generally, the correlating requirement is a set of user-specified radial distance to the event, whether the user is heading toward or away from an event area, whether the event is past, present, or future relative to the user and the duration of the event. Alternatively, the matching processor 140 could contain the criteria for predefined event types, with appropriate segments, being generated by unit 180 in general broadcaster 200. Specific examples of matching conditions would include whether a combatant was within the circular error probable (CEP) range of an impacting ballistic missile; remote user was within the path of a severe thunderstorm, NBC cloud, flash flood, or forest fire; or the path of the remote user

would intersect any of these events in the near future based on their respective velocities.

Dissemination may include audio, tactile or visual alarm or display, or any combination thereof, in display unit 152 and may be provided to one or more users. Dissemination may also include further processing at the processing unit 150 or at additional processing devices 155.

Although the present invention has been described above relative to exemplary preferred embodiments thereof, it will be understood by those skilled in the art that variations and modifications can be effected in these embodiments without departing from the scope and spirit of the invention as defined in the claims which follow.

What Is Claimed Is:

1. A communication system comprising:
 - a general broadcasting unit comprising
 - a message generating means for generating a message,
 - a segment generating means for generating a segment comprising at least one of a region, a velocity and a time, for incorporating said segment into said generated message, and for outputting an incorporated message, said generated message and said generated segment, and
 - a transmitter broadcasting said incorporated message;
 - a remote unit comprising
 - a receiver for receiving said incorporated message from said transmitter at said general broadcasting unit,
 - a storing means for storing data selection information,
 - a matching processor for evaluating said segment in said incorporated message, for determining if said data selection information of said remote terminal satisfies a match condition to said segment, and for outputting a match signal, and

a disseminating means, which receives said match signal, for processing and disseminating said message in accordance with said match signal.

2. The system as recited in claim 1, wherein said remote unit is mobile.

3. The system as recited in claim 1, wherein said remote unit is transportable.

4. The system as recited in claim 1, wherein said remote unit is fixed.

5. The system as recited in claim 1, wherein said segment generating means incorporates said segment as a header on said message.

6. The system as recited in claim 1, wherein said data selection information comprises current position, velocity and time information of said remote unit.

7. The system as recited in claim 6, further comprising a navigational information receiver receiving said current position, velocity and time information from a global navigational system.

8. The system as recited in Claim 1, wherein said segment further includes an event specific tag.

9. The system as recited in Claim 8, wherein said matching processor includes predetermined, stored event specific tags.

10. The system as recited in Claim 1, further comprising means for manually entering at least one of position, velocity, time and event specific information into said storing means.

11. The system as recited in claim 1, wherein said disseminating means includes a means for displaying said messages.

12. The system as recited in claim 1, wherein said disseminating means includes an alarm.

13. The system as recited in claim 1, wherein said data selection information comprises position, velocity and time information of objects of interest remote from said remote unit.

14. The system as recited in claim 1, wherein said data selection information comprises a location remote from said remote unit.

15. The system as recited in claim 1, wherein said message generating means further comprises a detecting means for detecting an event and generating a message in response to said event.

16. A method of providing selection at a remote unit of generally broadcast messages from a broadcaster, comprising the steps of:

transmitting from said broadcaster a message including a segment comprising at least one of a position, a velocity, and a time;

storing data selection criteria at said remote unit;

receiving at said remote unit said transmitted messages;

comparing said segment in said transmitted message to said stored data selection criteria;

determining from said comparing step the occurrence of a match condition; and

disseminating said message at said remote unit upon occurrence of said match condition.

17. The method as recited in claim 16, wherein said disseminating step includes displaying said messages.

18. The method as recited in claim 16, wherein said disseminating step includes activating an aural alarm.

19. The method as recited in claim 16, wherein said disseminating step includes activating a tactile alarm.

20. The method as recited in claim 16, wherein said disseminating step includes activating a visual alarm.

21. The method as recited in claim 16, wherein said disseminating step includes activating another device.

22. The method as recited in claim 16, which, prior to said transmitting step, further comprises the steps of:

detecting an event;

generating an event message in response to said event;

generating a segment defining at least one of a region, a velocity and a time; and

incorporating said segment into said event message to form said message.

23. The method as recited in claim 16, wherein said storing data selection criteria step comprises manually entering at least one of position, velocity, time and event specific information.

24. The method as recited in claim 16, wherein said storing data selection criteria step comprises receiving current position, velocity and time information of said remote unit.

25. The method as recited in claim 16, wherein said transmitted messages received at said remote unit when transmitted from more than one broadcaster.

26. The method as recited in claim 16, wherein said storing step comprises a plurality of data selection criteria and said comparing step comprises comparing said segment of said plurality of data selection criteria.

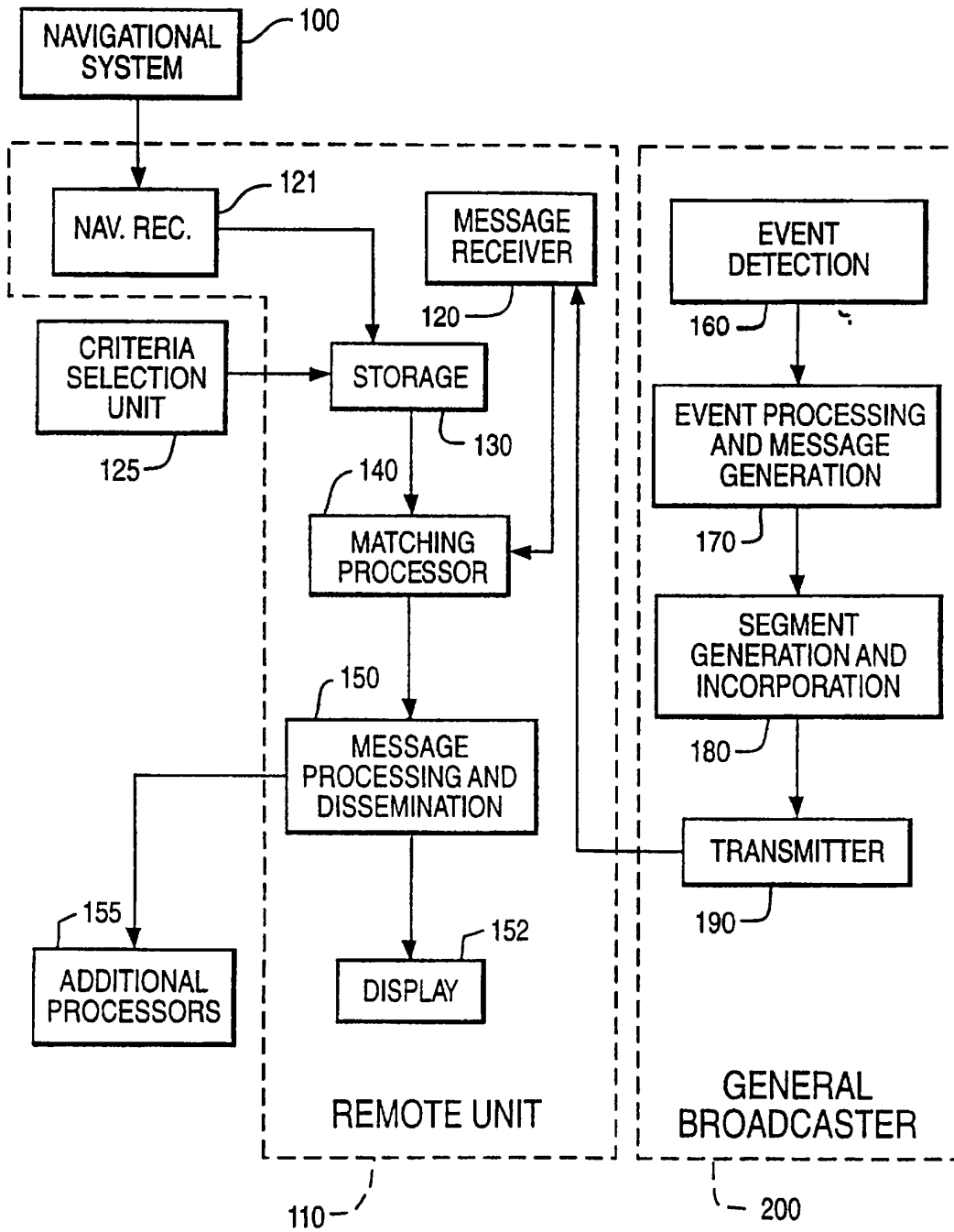

INTERNATIONAL SEARCH REPORT

International application No.

PCT/US95/10170

A. CLASSIFICATION OF SUBJECT MATTER

IPC(6) :HO4L 27/00, G08G 1/23

US CL : 375/37; 340/993

According to International Patent Classification (IPC) or to both national classification and IPC

B. FIELDS SEARCHED

Minimum documentation searched (classification system followed by classification symbols)

U.S. : 375/259, 340, 345; 340/993, 989, 988; 370/92, 85.1; 342/457; 364/449

Documentation searched other than minimum documentation to the extent that such documents are included in the fields searched
NONE

Electronic data base consulted during the international search (name of data base and, where practicable, search terms used)
APS

C. DOCUMENTS CONSIDERED TO BE RELEVANT

Category*	Citation of document, with indication, where appropriate, of the relevant passages	Relevant to claim No.
X ---- Y	US, A, 5,095,532 (MARDUS) 10 MARCH 1992, col. 2, line 36 - col.4, line 19.	1-6,8-11,13 - 14, 16-17, 19,23-26 ----- 7,12,18,20-21.
Y	US, A, 4,097,695 (GRACE ET AL) 27 June 1978, col.4, line 30 - col.6, line 34.	1-14, 16-21, 23-26.
A	US, A, 5,311,197 (SORDEN ET AL) 10 May 1994, see abstract.	1-26.
A	US, A, 4,627,052 (HOARE ET AL) 2 December 1986, see abstract.	1-26.

Further documents are listed in the continuation of Box C. See patent family annex.

* Special categories of cited documents:	*T* later document published after the international filing date or priority date and not in conflict with the application but cited to understand the principle or theory underlying the invention
A document defining the general state of the art which is not considered to be part of particular relevance	*X* document of particular relevance; the claimed invention cannot be considered novel or cannot be considered to involve an inventive step when the document is taken alone
E earlier document published on or after the international filing date	*Y* document of particular relevance; the claimed invention cannot be considered to involve an inventive step when the document is combined with one or more other such documents, such combination being obvious to a person skilled in the art
L document which may throw doubts on priority claim(s) or which is cited to establish the publication date of another citation or other special reason (as specified)	*Z* document member of the same patent family
O document referring to an oral disclosure, use, exhibition or other means	
P document published prior to the international filing date but later than the priority date claimed	

Date of the actual completion of the international search
23 SEPTEMBER 1995

Date of mailing of the international search report
20 DEC 1995

Name and mailing address of the ISA/US
Commissioner of Patents and Trademarks
Box PCT
Washington, D.C. 20231

Authorized officer *B. Hardw*
TEMESGHEN GHEBERTINSAE *jo*

Facsimile No. (703) 305-4714

Telephone No. (703) 305-4714



INTERNATIONAL APPLICATION PUBLISHED UNDER THE PATENT COOPERATION TREATY (PCT)

<p>(51) International Patent Classification ⁶ : G08B 5/22, 13/19, H04Q 1/00, 7/00, H04B 1/16</p>	<p>A1</p>	<p>(11) International Publication Number: WO 98/49661 (43) International Publication Date: 5 November 1998 (05.11.98)</p>
<p>(21) International Application Number: PCT/US98/08333 (22) International Filing Date: 24 April 1998 (24.04.98) (30) Priority Data: 08/845,912 25 April 1997 (25.04.97) US (71) Applicant: ALERT SYSTEMS, INC. [US/US]; 4601 Hammerley Road, Madison, WI 53711 (US). (72) Inventors: BELLIN, Robert, W.; 4916 North Highway 83, Hartland, WI 53029-9308 (US). POST, Kendall, E.; 5622 Old Middleton Road, Madison, WI 53705 (US). BLANDINO, Thomas, P.; 4670 Raven Way, Cottage Grove, WI 53527 (US). CLARK, Kenneth, R.; 5707 Winnequah Road, Monona, WI 53716 (US). (74) Agents: MANN, Philip, P. et al.; Suite 1900, 633 West Wisconsin Avenue, Milwaukee, WI 53203 (US).</p>		<p>(81) Designated States: AU, CN, JP, NZ, RU, European patent (AT, BE, CH, CY, DE, DK, ES, FI, FR, GB, GR, IE, IT, LU, MC, NL, PT, SE). Published <i>With international search report. Before the expiration of the time limit for amending the claims and to be republished in the event of the receipt of amendments.</i></p>

(54) Title: EMERGENCY MESSAGING SYSTEM

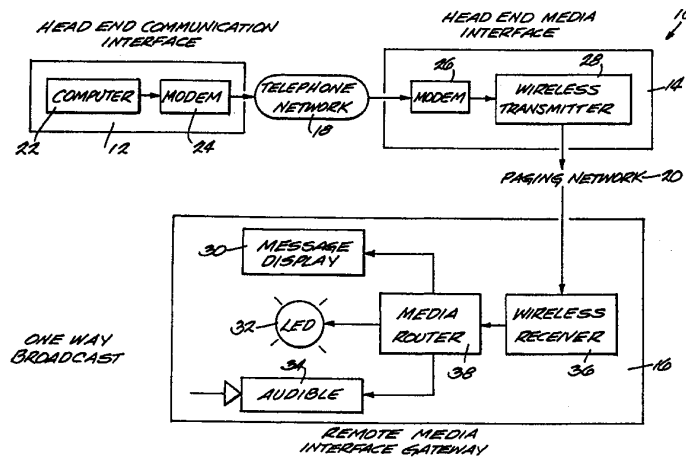

(57) Abstract

An emergency notification system (10) using selective call communications techniques is provided for communicating human and property safety information to and from recipients scattered over wide geographic areas. A computer controlled head end communications interface (12) adds subaddress information to a message to target intended recipients. A media router (38) directs the message through appropriate transport media in accordance with the address information. Preferably, the messages are communicated, at least in part, over existing paging systems. Additional transport media include existing power distribution networks, twisted wire pairs and fiber optics networks. Bi-directional reporting capability is provided. The system is well-suited for the communication of emergency notifications and warnings.

FOR THE PURPOSES OF INFORMATION ONLY

Codes used to identify States party to the PCT on the front pages of pamphlets publishing international applications under the PCT.

AL	Albania	ES	Spain	LS	Lesotho	SI	Slovenia
AM	Armenia	FI	Finland	LT	Lithuania	SK	Slovakia
AT	Austria	FR	France	LU	Luxembourg	SN	Senegal
AU	Australia	GA	Gabon	LV	Latvia	SZ	Swaziland
AZ	Azerbaijan	GB	United Kingdom	MC	Monaco	TD	Chad
BA	Bosnia and Herzegovina	GE	Georgia	MD	Republic of Moldova	TG	Togo
BB	Barbados	GH	Ghana	MG	Madagascar	TJ	Tajikistan
BE	Belgium	GN	Guinea	MK	The former Yugoslav	TM	Turkmenistan
BF	Burkina Faso	GR	Greece		Republic of Macedonia	TR	Turkey
BG	Bulgaria	HU	Hungary	ML	Mali	TT	Trinidad and Tobago
BJ	Benin	IE	Ireland	MN	Mongolia	UA	Ukraine
BR	Brazil	IL	Israel	MR	Mauritania	UG	Uganda
BY	Belarus	IS	Iceland	MW	Malawi	US	United States of America
CA	Canada	IT	Italy	MX	Mexico	UZ	Uzbekistan
CF	Central African Republic	JP	Japan	NE	Niger	VN	Viet Nam
CG	Congo	KE	Kenya	NL	Netherlands	YU	Yugoslavia
CH	Switzerland	KG	Kyrgyzstan	NO	Norway	ZW	Zimbabwe
CI	Côte d'Ivoire	KP	Democratic People's	NZ	New Zealand		
CM	Cameroon		Republic of Korea	PL	Poland		
CN	China	KR	Republic of Korea	PT	Portugal		
CU	Cuba	KZ	Kazakstan	RO	Romania		
CZ	Czech Republic	LC	Saint Lucia	RU	Russian Federation		
DE	Germany	LI	Liechtenstein	SD	Sudan		
DK	Denmark	LK	Sri Lanka	SE	Sweden		
EE	Estonia	LR	Liberia	SG	Singapore		

EMERGENCY MESSAGING SYSTEM**RELATED APPLICATION**

5 This is a Continuation-in-Part of U.S. Patent Application Serial No. 08/696,014 filed August 20, 1996.

BACKGROUND OF THE INVENTION

10 This invention relates generally to emergency notification systems and, more particularly, to systems for communicating human and property safety, address-specific, limited content messages in one or two directions via selective call communications links.

15 The need to communicate address-specific, limited content data messages over wide areas arises in emergency situations is growing. Since 1934, people have been dependent on outdoor warning siren systems, initially implemented for national security reasons. In 1951, siren systems were formally organized nationwide as a Civil Defense warning method. Since that time, however, sirens have become antiquated and at times function poorly. Urban growth has outstripped coverage in other cases. Other limitations of siren emergency warning systems include (a) they are not heard inside shopping malls or on factory floors, (b) they make noise but do not deliver information or instructions, (c) performance is affected by weather conditions, (d) they malfunction frequently and have high maintenance and replacement costs, and (e) they do not reach the deaf or hearing impaired.

20
25
30

Another civil warning system is based on the commercial radio and TV broadcast stations. The Emergency Broadcast System (EBS)/Emergency Alerting System (EAS) (a) does not reach people when they are asleep, (b) reaches only those listening to radio or watching television, (c) does not reach hearing impaired, (d) depends upon voluntary broadcaster participation, (e) limited when radio stations are day-time only or automated during the night, (f) limited when news/weather departments are unmanned at night, (g) relies on unreliable daisy-chain alarm technology. (EBS), (h) depends greatly on human performance, (i) does not function without AC power, and (j) does not serve people in shelters unable to access television and radio.

The Nation Oceanic and Atmospheric Agency's (NOAA) weather radio system is another civil warning system. It is limited by (a) its need for a special radio, (b) spotty geographic signal coverage, (c) the small percentage of users in general population, (d) weather only information, (e) does not reach hearing impaired, (f) signals are adversely affected in locations such as basements or heavily wooded areas.

While the message distribution systems of EAS and other existing emergency systems do preface messages with message source, coverage area, and other control information, this control information cannot precisely target many local, limited area, or arbitrary boundary emergency situations. The control information is suited for wide area situations and was designed primarily for use by news broadcast and other media rather than general public.

Existing emergency notification systems are

- 3 -

also limited by other factors including dependence
on AC power. When evacuation of a population
segment is required and AC power outages are
widespread, the only option currently available to
5 emergency managers is a slow and lengthy door-to-
door, or block-by-block notification process. The
delayed notification increases the potential for
loss of human life. In addition in the case of
hazardous material incidents, slow general
10 population protection efforts often delay
containment efforts increasing containment and/or
remediation costs.

In past major disasters, people accepted as
the norm, informational delays, rumors, power
15 outages (eliminating TV/Radio services),
uncoordinated governmental delivery systems and
inaccurate information. They accepted the
limitations of existing communications systems. But
expectations of the general population increase as
20 the Internet, satellite TV and other rapid
communications appliances become ever more
commonplace. Political fall-out has been
considerable where evacuation announcements and
efforts have not reached everyone in a timely
25 manner.

The EAS/EBS and other existing emergency
warning systems are valuable aids to emergency
managers but such broadcasts, effective as they are
in transmitting information over a wide area, are,
30 by nature, not address specific. Accordingly, they
are transmitted equally to those who are affected by
the crises as well as to those who are not.
Although address-specific, wire-based communications
links, such as private telephone lines have existed
35 for years, the cost of providing dedicated lines for

- 4 -

relatively limited communications needs is prohibitive.

5 One form of existing wireless communications that solves part of the address-specific message targeting problem is the radio paging system of known configuration. Such selective call radio systems combine the speed and coverage of wireless "broadcast" techniques with the address-specific capabilities of wire-based systems. 10 Such paging systems are also configured for the address-specific transmission of limited data messages. Accordingly, wireless paging systems can be well suited for providing cost-effective, efficient and immediate, limited communications 15 between for example, utilities and police, fire and disaster control authorities on the one hand, and widely dispersed community residents on the other.

Unfortunately, existing radio paging systems are not a total solution for emergency notification. Paging systems commonly use receivers that recognize a limited number of single level address selection (variously Code Assignment Plan (CAP), or Capture) codes. Because of these and other technical limitations, emergency managers have 20 generally restricted radio paging and other selective call system usage to emergency and political personnel.

SUMMARY OF THE INVENTION

25 The invention provides a method of operating a wireless system so as to communicate messages to specific groups among a plurality of potential message recipients according to the presence or absence of the potential message recipients within a specified geographic area. The 30 method comprises the steps of equipping each of the 35

potential message recipients with a wireless receiver operable to receive encoded geographic coordinates and to determine presence or absence within an area defined by the received encoded geographic coordinates, identifying the geographic coordinates defining the specific geographic area to which the group specific message is directed, transmitting to each of the receivers a message containing an informational portion and a portion containing the geographical coordinates of the specified geographic area, determining at each of the receivers presence or absence within the specified geographic area, and displaying the informational portion of the message at the receivers determined to be within the specified geographic area.

The invention also provides a method of operating a wireless communications system having a plurality of receivers each responsive to a common base address and to a unique individual address. The method comprises the steps of generating for each of the receivers a unique identification code, locating each of the receivers at a specific geographic location, generating for each of the receivers a location code indicative of the specific geographic location associated with the receiver, and communicating via a wireless communications link the unique identification code and the location code to respective ones of the receivers.

In one embodiment, the method comprises the further steps of relocating a receiver to a different geographic location, generating a new location code indicative of the receiver's different geographic location, and communicating via a wireless communications link the new location to the

relocated receiver.

The invention also provides a method of operating a wireless system so as to communicate group specific messages to specific groups among a plurality of potential message recipients. The method comprises the steps of identifying specific groups among the plurality of potential message recipients, assigning to each of the identified specific groups a group specific address, equipping each of the potential message recipients with a wireless receiver responsive to the group specific address of the specific group to which the potential message recipient belongs, generating a message containing an informational portion and an address portion, the address portion including the group specific address of the specific group intended to receive the message, transmitting via a wireless signal the message over a geographic area containing the potential message recipients so that the receivers responsive to the group specific address will accept the message and communicate the informational portion of the message to the member of the specific group, and verifying the existence of authority to transmit the message to the specific group before transmitting the message to the specific group.

The invention also provides a method of operating a wireless system so as to communicate group specific time sensitive messages to specific groups among a plurality of potential message recipients. The method comprises the steps of identifying specific groups among the plurality of potential message recipients, assigning to each of the identified specific groups a group specific address, equipping each of the potential message

- 7 -

recipients with a wireless receiver responsive to the group specific address of the specific group to which the potential message recipient belongs, generating a message containing an informational portion, an address portion, and a time duration portion, the address portion including the group specific address of the specific group intended to receive the message, transmitting via a wireless signal the message over a geographic area containing the potential message recipients so that the receivers responsive to the group specific address will accept the message and communicate the informational portion of the message to the member of the specific group, decoding the time duration portion of the message to define a time period, and deleting the informational portion of the message following expiration of the time period.

In one embodiment, the method comprises the further step of resetting each of the receivers following expiration of a predetermined time interval.

The invention also provides a receiver unit for use in a pager-based communications system operable to direct messages to specific groups of pagers within a larger group of receivers within the service area of the system. The receiver unit comprises a wireless receiver responsive to a base address, a decoder coupled to the wireless receiver for recognizing a group-identifying indicator indicative of inclusion within the specific group, an audible alarm annunciator responsive to the wireless receiver and the decoder for sounding an audible alarm in the event of receipt of an alarm message directed to the receiver unit, and control circuitry for silencing the audible alarm after

passage of a predetermined time period following receipt of the alarm message.

5 In one embodiment the control circuitry is further operable to reduce the audio level of the audible alarm in response to appropriate control signals received from the wireless receiver.

10 The invention also provides a method of operating a wireless communications system. The method comprises the steps of generating a message having a base address portion, a control instruction portion and an informational portion, transmitting the message via a wireless signal, receiving the transmitted message on a receiving unit operable to respond to messages containing the base address,
15 decoding the control instruction portion of the message and, in response to receipt of an appropriate decoded control instruction, thereafter transferring the informational portion of the message to a different paging system for
20 distribution over the different paging system.

The invention also provides a receiver unit for use in a pager-based communications system operable to direct messages to specific groups of pagers within a larger group of receivers within the
25 service area of the system. The receiver unit comprises a wireless receiver responsive to a base address, a decoder coupled to the wireless receiver for recognizing a group-identifying indicator indicative of inclusion within the specific group,
30 an audible alarm annunciator responsive to the wireless receiver and the decoder for sounding an audible alarm in the event of receipt of an alarm message directed to the receiver unit, and control circuitry for silencing the audible alarm after
35 passage of a predetermined time period following

receipt of the alarm message.

The invention also provides a receiver unit for use in a pager-based communications system operable to direct messages to specific groups of pagers within a larger group of receivers within the service area of the system. The receiver unit comprises a wireless receiver responsive to a base address, a decoder coupled to the wireless receiver for recognizing a group-identifying indicator indicative of inclusion within the specific group, circuitry coupled to the decoder and the wireless receiver for recognizing an informational portion of a message directed to the specific group of receivers, and additional circuitry responsive to an informational input received independently of the message directed to the specific group of receivers.

In one embodiment, the informational input comprises a signal indicative of the geographic location of the receiver unit.

In one embodiment, the informational input is obtained from a global positioning system receiver.

In one embodiment, the informational input is derived from a sensor located in the vicinity of the receiver unit.

In one embodiment, the sensor is selected from the group consisting of baby monitors, telephone monitors and door bell ring detectors.

In one embodiment, the receiver unit further includes a memory for storing one or more previously recorded messages and a display for displaying the previously recorded message in response to receipt of an appropriate informational input.

In one embodiment, the receiver unit

further includes a non-aural based indicator for indicating receipt of an informational input.

5 In one embodiment, the receiver unit further includes an alternate source of operating energy.

In one embodiment, the receiver unit further includes the alternate source comprises a battery-operated power supply.

10 In one embodiment, the receiver unit further includes a light source actuated upon actuation of the alternate source.

15 It is an object of the invention to provide a new and improved system for communicating with specific groups among a plurality of geographically dispersed potential recipients.

20 It is a further object of the invention to provide a communications system that permits communication with specific ones of several remote sites in a geographic area while utilizing existing, low-cost communications media.

25 It is a further object of the invention to provide a communications system that permits remote accessing of data generated at various specified ones of a plurality of remote sites dispersed over a geographic area.

30 It is a further object of the invention to provide a communications system that permits automatic communication of an alarm or other such non-scheduled message automatically from a remote site to a central location using existing, low-cost communications media.

35 It is a further object of the invention to provide a communications system that permits remote control of specific remotely located devices over a wide geographic area using existing, low-cost

communications media.

It is a further object of the invention to provide a communications system that includes a media routing feature that provides for communications through various available media in accordance with the type, location and nature of communication needed.

It is a further object of the invention to provide a communications system that incorporates a logic protocol feature for translating between the logic/application level protocols of different physical media.

Brief Description of the Drawings

The features of the present invention which are believed to be novel are set forth with particularity in the appended claims. The invention, together with the further objects and advantages thereof, may best be understood by reference to the following description taken in conjunction with the accompanying drawings, wherein like reference numerals identify like elements, and wherein:

FIGURE 1 is a simplified block diagram of a one-way, pager-based communications system embodying various features of the invention

FIGURE 2 is a simplified block diagram of a one-way, pager-based alarm reporting communications system embodying various features of the invention.

FIGURE 3 is a simplified block diagram of a pager-based, two-way meter reading communications system embodying various features of the invention.

FIGURE 4 is a simplified block diagram of a pager-based, one-way remote control communications system embodying various features of the invention.

FIGURE 5 is a simplified block diagram of a first embodiment of a logical/application protocol conversion system embodying various features of the invention and useful in conjunction with the pager-based communications systems herein disclosed.

FIGURE 6 is a simplified block diagram of another embodiment of a logical/application protocol conversion system embodying various features of the invention and useful in conjunction with the pager-based communications systems herein disclosed.

FIGURE 7 is a simplified block diagram of one form of network operable to interconnect the communications elements of two separate devices coupled to different lines of a three-wire power distribution system.

FIGURE 8 is a simplified block diagram of another form of network operable to interconnect the communications elements of two separate devices coupled to different lines of a three-wire power distribution system.

FIGURE 9 is a simplified block diagram of a switchable network embodying various features of the invention useful in interconnecting the communications elements of various devices coupled to different lines of a three-wire power distribution system.

FIGURE 10 is a simplified block diagram of an alternate embodiment pager-based communications system offering still further flexibility in directing various types of communications to and from various ones or subgroups of receivers within a paging area.

FIGURE 11 is a simplified geographic depiction of a coverage area serviced by a pager-based communications system, useful in understanding

- 13 -

one approach to communicating with receivers located within a selected sub-area located within the broad coverage area.

5 FIGURE 12 is a simplified block diagram, similar to FIG. 1 of an alternate embodiment of a one-way pager based communications system embodying various features of the invention.

Description of the Preferred Embodiment

10 Referring to the drawings and, in particular, to Fig. 1, a simplified block diagram of a pager-based communications system 10 is illustrated. In accordance with one aspect of the invention, the system 10 is configured to communicate information from a central location to
15 a specific group of potential message recipients scattered over a wide geographic area. In the illustrated embodiment, the system is particularly well suited for use by public safety departments, disaster warning agencies and the like to transmit
20 limited, content specific messages to particular groups of recipients among a larger group of potential recipients. For example, the system can be used by a metropolitan disaster agency to warn particular residents of a community (e.g. those
25 residents living in the flood plain of a river) of an impending situation affecting only those residents (e.g., imminent flooding along the river). Although a signal is broadcast over the entire community and, hence, is potentially receivable by
30 every member of the community, the system 10 functions automatically to direct the message to the affected members without also directing the message to the unaffected members. This helps ensure that the affected members receive the message and also
35 helps avoid "bothering" the unaffected members with

a message that does not concern them. In accordance with a principal aspect of the invention, the system is easily and economically implemented using substantially existing communications media that are already in place.

In the illustrated embodiment, the system includes a head end communication interface 12, a head end media interface 14 and a remote media interface gateway 16. The head end communication interface 12 communicates with the head end media interface 14 via a telephone network 18 of known construction, and the head end media interface communicates with the remote media interface gateway 16 via an existing paging network 20, also of known construction. In the illustrated embodiment, the head end media interface actually makes up part of the paging network and can be of conventional, known construction. The head end communication interface 12 originates the message to be communicated to the specified group of potential recipients and includes a computer 22 coupled to the telephone network through a modem 24. Although an existing telephone network 18 is contemplated, it should be understood that the particular type of system used is not critical to the invention, and that other forms of existing and future communications systems, i.e., analog or digital, wireless personal communications, coaxial, broad-band fiber, optics etc., can be used.

It is assumed that specified groups of potential recipients have been previously identified according to some selection criteria. For example, potential recipients can be classified according to such factors as (a) physical location within the geographic area or (b) membership in an emergency response organization, utility or municipal crew,

- 15 -

media outlet, etc. In any event, the potential recipients are classified according to group and are assigned a unique identifier or "subaddress" unique and common to members of the specific group. The particular classification or assignment of group is not critical to the invention, and the types of classifications herein referenced are for illustrative rather than limiting purposes.

The computer 22 functions to keep track of the specific groups and their unique addresses and further functions to add the appropriate address to messages intended for specific groups. Thus, if a message is to be sent to a specific group of potential recipients, the computer identifies the appropriate address and incorporates the address into the message. The message with the incorporated address is then communicated through the modem 24 and existing telephone network 18 to the head end media interface 14. The head end media interface 14 includes a modem 26 that receives the message with the incorporated address and supplies both the message with the incorporated address to a wireless transmitter 28 for broadcast over the paging network 20.

In accordance with another principal aspect of the invention, the address information that identifies the specific group to receive the message is added into the message and is in addition to the single operating base address that is procured from the pager service provider. Thus by incorporating the group-specific address information into the message itself, the system 10 allows single device or pre-determined grouping of several devices using a single operating base address. Because only a single base address need be procured from the pager

service provider, considerable economy is realized.

The system 10 allows an emergency management agency to target specific operating areas based on operational or warning needs. The remote media interface gateway functions to route the message, after its receipt by the targeted group member, to an appropriate display based on the type of message received. For example, the remote media interface gateway can include various types of displays, such as an alphanumeric display 30, an LED display 32 and an audible warning 34, coupled to a wireless receiver 36 through a media router 38. After the message is received by the wireless receiver 36, the media router interprets additional information coded into the message to determine the nature of the message and direct the message to the appropriate display. Warnings of severe weather or other emergency conditions can be displayed alphanumerically while the audible warning attracts the recipient's attention with a sound level and pattern indicating message urgency. The audible warning could be used, for example, to alert the user to view the detailed information appearing on the message display 30. Preferably, the various indicator devices 30, 32 and 34, and the media router 38 and wireless receiver 36, are all integrated into a single unit comprising the remote media interface gateway 16.

Referring to Fig. 2, another system 40 embodying the invention is illustrated. In this system 40, communication from a remote site back to a central location is provided. The system 40 includes a head end communication interface 12 coupled to a telephone network as in the previously described system 10 of Fig. 1. In addition, the

system 40 includes a head end media interface 42 that has a wireless receiver 44 coupled to the telephone network 18 through a modem 46. The system further includes a local network function module 48 and a remote media interface gateway 50 coupled to the local network function module through some form of transport medium. As used herein, such a transport medium is intended to include any medium through which electrical or optical signals or energy can be transported from one location to another and includes, for example, power distribution networks and wiring, telephone or data communication networks, wireless links, optical fibers and the like. The remote media interface gateway communicates with the head end media interface 42 through a paging network 52 having a wireless transmitter 54 associated with the remote media interface gateway 50 and a wireless receiver 44 associated with the head end media interface 42.

The system 40 is particularly well suited for communicating a signal, such as an alarm signal or serial data stream, from a remote location to a central location such as a police station or private security headquarters. In accordance with one aspect of the invention, the system 40 makes use of existing links, such as power wiring, to communicate signals to and from the remote location. To this end, the local network function module 48 includes a control input and output circuit 56 that receives an alarm function 58 from an appropriate source, such as, for example, a burglar or fire alarm, and generates an appropriate alarm message incorporating the location of the emergency as well as its nature. The message is supplied to the available transport medium 60, such as the power line network, for

- 18 -

transmission to the remote media interface gateway 50. The remote media interface gateway 50, which is located remotely from the local network function module 48, receives the message through an appropriate transport medium input port 62 that is coupled through a media router 64 to the wireless transmitter 54.

The wireless transmitter 54 transmits the message over the paging network 52 back to the wireless receiver 44 of the head end media interface 42. The message thus received is communicated through the modem 46, the telephone network 18 and the modem 24 to the computer 22 of the head end communication interface 12.

To facilitate communication, enhance economy and provide system flexibility, the system 40 "keeps track" of the various communications media through which the various remote locations and their associated local network function modules 48 are interconnected with the remote media interface gateway 50. For example, those remote locations that are interconnected through the power distribution network (transport media #1) are categorized according to type and designated with a particular address element that is recognized by the media router 64. When a message intended for or received from a remote site connected through the power distribution network is to be communicated, the media router selects the appropriate transport medium, in this case medium # 1. Other remote sites might be coupled to the remote media interface gateway 50 through other media such as a wireless link (transport medium #2). Messages from or to such remote sites are directed, through the media router 64, to the appropriate transport medium, in

- 19 -

this case transport medium #2. By utilizing existing communications links, the system 40 permits one-way alarm reporting in an economical manner. When a message from a remote site is received and routed back to the head end communication interface, the computer decodes the message as to type (fire, security breach etc.) and location and directs an appropriate display to the proper personnel.

Referring to Fig. 3, another system 66 embodying the invention is illustrated. System 66 is particularly well suited for requesting and receiving data from remote locations dispersed over a wide geographic area. In this system 66, a head end communication interface 68 having a computer 22 and a modem 70 operable in a bi-directional mode is used as is a head end media interface 72 having a bi-directional modem 74, a wireless paging transmitter 76 and a wireless paging receiver 78. The head end communication interface 68 and the head end media interface 72 communicate through the telephone network 18. A remote media interface gateway 80 is provided that includes a wireless transmitter 82 and a wireless receiver 84 that are coupled to a media router 86 that in turn is coupled to one or more transport media 62, such as the power distribution network. Finally, the system 66 includes, at one or more remote sites, one or more local network function modules 88. The local network function module 88 includes an interface 60 to the connected transport medium and further includes a control input and output circuit 90 and, in the illustrated exemplary embodiment, a usage meter 90. The usage meter 92 comprises an electric consumption meter and is shown only as an example and not as a required element of the invention. In

- 20 -

the illustrated embodiment, the system 66 enables a centralized agency, such as a power utility company, to read electric power consumption meters located at remote sites from the central location and without having to send personnel to the remote site.

In operation, the system 66 first generates a page at the head end communication interface 70 that is communicated through the telephone network 18 to the head end media interface 72. The computer 22 generates an appropriate address indicative of the remote site to be interrogated as well as an appropriate interrogation request. The message thus generated is transmitted via the wireless transmitter 76 to the remote media interface gateway 15 which decodes the proper address and message request type. The media router 86 directs the message request through the appropriate transport medium to the local network function module 88, which decodes the request and obtains the requested information. 20 The local network function module 88 then communicates the requested information back through the appropriate transport medium to the remote media interface gateway 80, that, in turn, transmits the requested data to the head end media interface 72 for further communication back to the head end 25 communication interface 68. In each case, proper routing address information would be incorporated into both the message sent to the local network function module 88 and in the return message sent 30 back to the head end communication interface 68 from the remote location. The head end communication interface 68 would then organize the information by displaying the initial meter reading request for a given address with the actual reading received. 35 Alternatively, the reporting function can occur as

part of a pre-determined schedule, protocol or other plan rather than through direct request.

Referring to Fig. 4, another system 94 embodying various features of the invention is shown. This system 94 permits remote command of remotely located devices from a central location. In particular, the system provides for sending a specific control command to a remote device and meets two immediate needs. The first is to enable a remote authority, such as, for example, a power utility company, to remotely control devices, such as water heaters or air conditioners, so as to enable the power utility to change demand at times of peak load. The second is to enable a user to control devices, such as a residential heating system, from a remote location.

The system 94 is similar to the one-way broadcast system of Fig. 1 and includes the head end communication interface 12, the telephone network 18 and the head end media interface 20. The system further includes a remote media interface gateway 96 including a wireless receiver 84, media router 86 and various transport media 62, such as a power distribution network. Finally, the system 94 includes a local network function module 98 that, like that of the system 66 shown in Fig. 3, includes a transport medium interface 60 and control input and output circuit 90, but has a load control 100 coupled to the control input and output circuit 90. The load control 100 is operable, in response to applied external commands to control an external load or device.

In operation, a page is sent from the one-way head end unit 12 and the head end media interface 14 with the transmitter 28 first sending

- 22 -

the data to the remote media interface gateway through the paging network 20. The remote media interface gateway 96 decodes the proper address and control message type and/or function and then routes
5 the request through the proper local transport medium, such as a power line, to the local network function models 98. The local network function module 98 decodes the message and turns the device on or off as required.

10 In the system 94, the communication is one-way from the head end media interface 14 to the remote media interface gateway 96. The head end communication interface organizes the information by matching the remote address location and control
15 function type by displaying the address with the actual control function desired. The needs met by the system 94 require the ability to reach a wide range of remote locations organized by specific groups or even a single location. The
20 reception/address information is contained in the actual message and is decoded by the remote media interface gateway 96. Existing paging systems operate by sending a single base address to a single receiver. By adding additional address information
25 into the message, the system 94 allows single device or pre-determined grouping of several devices using a single operating base address. This provides a great economic advantage in that only one base address need be procured from a pager service
30 provider. The system 94 enable a utility to target specific operating areas based on operational needs, such as electrical load to be shed.

In accordance with still another aspect of the invention, capability is provided for performing
35 logic/application level protocol translations

between different physical media where required to
execute various services. This allows components of
different manufacturers to be interconnected into a
single interoperable system. For example, security
5 sensor operational alarms on an Echelon LonTalk
system can be passed to a X.10 Bus lighting system
so that outdoor lights can be turned on when an
alarm transmission is generated by the remote media
interface gateway as part of reporting a
10 transmission to the head end communications
interface. Such an approach is shown in the system
102 of Fig. 5 wherein a remote media interface
gateway 80 of the type shown in Fig. 3 communicates
with a plurality of local network function modules
15 88, 88' and a logical protocol conversion takes
place between the two local network function modules
88, 88'. A similar system 104 is shown in Fig. 6.

Referring to FIG. 6, the system 104
includes a remote media interface gateway 112, which
20 includes a control processor 110 coupled to the
media router 86 but is otherwise similar to the
remote media interface gateway 80 shown in FIGS. 3
and 5. A security sensor 106 coupled to an Echelon
LonTalk transport medium 108 is coupled to the
25 control processor 110. When the security sensor 106
detects an alarm condition, the alarm message thus
generated is transported to the control processor
110 through the media router 86 to the wireless
transmitter 82. The transmitter 82 sends the alarm
30 message to a remote head end communication interface
22 (Fig. 3). The control processor 110 recognizes
the security sensor 106 operation as an alarm
condition and matches this sensor operation to a
logical look-up table in the attached memory 113.
35 The table indicates that, when the sensor 106

operates, a lighting control function (i.e., turn on the light) is desired. A functional module 114 is coupled to the light and is also coupled to the media router 86 through the second transport medium 116. In this example, two logical functions are connected between two different physical media that are not directly compatible at the physical level.

As previously noted, the various communications systems disclosed herein make use of the power distribution system as an important available transport medium. Typically, power is distributed by means of a three-wire system having two "hot" lines, L1 and L2, and one neutral line. Typically, 240 V power is available across lines L1 and L2 while 120 V power can be obtained between either of the lines L1 or L2 and neutral. Because the communications systems disclosed herein might require communications between devices coupled to different lines of the power distribution system, various coupling networks are provided for permitting such communication.

FIG. 7 shows a system 118 for permitting power line communication between devices that operate on 120 VAC and that are connected to the neutral line and different ones of the "hot" lines, L1 and L2. In this system, a coupling capacitor 122 couples a transport medium transceiver 124 to both lines L1 and L2. High frequency signals transmitted by the transceiver 124 thus appear on both of the lines L1 and L2.

FIG. 8 shows a network 126 suitable for permitting communications between devices that operate at 240 VAC and that are coupled between both of the lines L1 and L2. In this system 126, the transport medium transceiver is simply connected to

both of the lines L1 and L2.

Neither of the systems 118 or 126 permits communications between all devices regardless of whether they are connected between L1 and neutral, L2 and neutral or between L1 and L2. Accordingly, and in accordance with one aspect of the invention, a switchable interface network 128 is provided. The system 128 includes a controllable medium switch 130 that is connected as shown. In the system 128, lines L1 and L2 are coupled, at signal frequencies, by the capacitor 122. One side of the transport medium transceiver 124 is coupled directly to line L2 and, through the capacitor 122, to line L1. The other side of the transport medium transceiver 124 is connected to the common pole of the medium switch 130. The medium switch 130 functions to couple the transport medium transceiver 124 to either the neutral line or to line L1. When the medium switch 130 is in a first position, position 1, the transport medium transceiver 124 is coupled to the neutral line and hence is configured for communications with 120 VAC devices coupled between lines L1 and L2 and neutral. When the medium switch 130 is in the opposite position, position 2, the transport medium transceiver 124 is configured for communications with 240 VAC devices connected across line L1 and L2. The medium switch 130 is under the control of the media router 86 (FIGS. 3-6) which sets the medium switch 130 as required for the desired communication. The system 128 thus provides complete flexibility for communications via the power lines among various different, and differently connected, devices.

Still another pager-based communications system 200 embodying various features of the

previously described systems is shown in FIG. 10. In this system 200, further flexibility in communicating to and from selected subgroups of users is provided.

5 In FIG. 10, one or more head end communications interfaces 202 are provided. Each of the head end communications interfaces 202 can communicate with any one of a plurality of wireless communications media 204, such as separate, existing
10 paging systems. A plurality of remote media interface gateways 206, each responsive to a particular one of the wireless communications media 204, are also provided. Each of the remote media interface gateways, in turn, is coupled to one or
15 more local network function modules indicated generically at 208.

 As previously noted, one important function of the pager-based communications systems described herein is to broadcast a single message or item of
20 information over a wide area serviced by a wireless communications medium. Such a function can be served, for example, by transmission of an alphanumeric character message to one or more remote locations for emergency or disaster warnings, such
25 as severe weather, a chemical spill or other such local, hazardous environmental condition. This function requires the ability to reach a wide range of remote locations organized by specific groups or even a single location.

30 In operation, a message or data string is sent by one of the wireless communications media or transmitters 204 to one or more of the paging receivers 208. This can be accomplished using known, one-way, telephone dial up modem,
35 alphanumeric paging techniques. A single base

- 27 -

address sent by the transmitter 204 to all receivers 208 within the service area, activates each of the receivers 208 responsive to the base address in the conventional manner. However, additional subaddress information, included in the message itself or otherwise appended onto the base address, is decoded and used by the individual receivers 208 in the manner previously described, to determine whether they are part of the predetermined subgroup for which the particular message or information is intended.

Given the capability of the pager-based communications systems described herein to address preselected or determined subgroups among all the selective call receivers located within the pager service area, various desirable ends can be achieved.

One example of a function for which the selective call communications systems described herein can be used to advantage is to define particular subgroups according to some predefined selection criteria, such as standard industrial classification (SIC) codes, arbitrary geographical boundary areas as dictated by tornado paths, or governmental boundary areas. By adding such selection information into the message and thereafter decoding it in the individual receivers 208, the receivers 208 can, on an individual basis, determine whether they are part of the intended receiving group. If not, they can ignore the message. If they are, they can respond as is appropriate. The various pager-based communications systems described herein can be used to contact anywhere from one single receiver up to all the receivers in various combinations or subgroups.

One important mode of operation is in using the pager-based communications system to contact receivers within a defined geographic subarea of the overall service area. One way to achieve this is through use of the latitude and longitude grid method depicted in FIG. 11. In this method and system, the agency generating or originating the message defines the intended receipt subgroup in terms of location within a rectangular area bounded by known geographic coordinates.

In FIG. 11, it is assumed that the message is intended for all receivers within the rectangular area bounded by the four geographic coordinate points 210, 212, 214 and 216. The geographical coordinates are selected to correspond with the actual physical location of the area for which the message is intended and is preferably generated using a geographical map generated by a computer and displayed on a screen within the agency generating the message. By highlighting an individual area on a computer based mapping system, individual coordinates can be established for any point. By selecting four grid coordinates, a rectangular area defined along actual longitude and latitude lines, an area of desired contact can be established. By selecting and using the paging system to broadcast these four points, individual receivers 208 can determine whether they are contained within the selected area and can act accordingly.

As shown in FIG. 11, a very simple subtracting method is used by each individual receiver to determine whether it is present within the selected area. In North America, for example, the receiver 208 is within the selected area if its known geographical coordinates are such that its

latitude is less than the latitudes of points 210 and 212 but greater than the latitudes of points 214 and 216, and if its longitude is less than the longitudes of points 210 and 214 but greater than the longitudes of points 212 and 216. A simple algorithm resident in each receiver 208, along with pre-installed information regarding the receiver's physical location can be used to determine whether the receiver is within the intended reception area.

More sophisticated methods can be used to select reception areas having shapes other than the simple rectangle shown. For example, multiple coordinates can be specified by the originating agency and transmitted via the paging system to define a selected reception area that is polygonal in shape. Still more sophisticated techniques can be used to define an arbitrary shape. Various algorithms can be used both in the head end communications interfaces 202 and in the function modules 208 to achieve these ends.

Still another advantageous feature that can be incorporated into one of the pager based communications systems described herein is the ability to use single or multiple message launch sites. In other words, a message that is to be transmitted to a one or more receivers can originate at more than one site and can be transmitted over the service area via one or more transmitters. In any event, the same base address is used, and only one base address need be procured from the pager service provider. This helps keep the system economical. Additionally, each additional launch site can be provided with similar or identical software, which provides redundancy in the event of a disaster without significantly increasing cost.

- 30 -

Another feature that can be incorporated is the ability to provide for over-the-air registration of individual receiving devices 208. This can be accomplished by correlating individual receiver identification numbers and address information (both longitude and latitude grid locations and governmental boundaries) to individual message launch sites. Thereafter, this information is sent to the individual receiver 208 using whichever transmitter 204 is connected to the originating message generating site. This feature also enables individual receivers 208 to be reused at a different address or location by over-the-air re-registration of the receiver 208.

Still another feature that can be incorporated is the ability to provide user authentication of the actual individual who generates the message sent to a paging transmitter 204. This increases system security by limiting access for sending messages and thus helps avoid the transmission of unauthorized messages. User authentication can be achieved by adding pass/challenge software at both the message launch site and the computer that controls access to the paging transmitter 204.

Still another feature that can be incorporated is the ability to generate time sensitive, self deleting messages that automatically erase themselves after passage of a set period of time. This feature can be implemented by inserting an additional item of information into the message that defines the length of time the message should remain in effect. The individual receivers 208 use the time out information to either retain the message or to delete it from memory if the message

is stale. This feature can be used to achieve the automatic resetting of all features in the receiver 208, and provides for hands off, automatic operation. This can be of value for use in spaces, 5 such as hotel rooms, where continuous occupancy is not feasible.

Still further refinements can be made through the inclusion of suitable control commands embedded in the messages sent to the individual 10 receivers. In particular, an embedded code can control the amplitude, duration and pattern of audio alarms and visual annunciators so that emergency messages convey urgency audibly and visually.

Still further refinements can be made 15 through the inclusion of suitable first digits in the command portion of the message which defines the organization and content of subsequent groups of subaddresses so subaddresses can have different representations such as latitude and longitude 20 coordinates, or governmental units.

Still further refinements can be made by the inclusion of a digit or character string in the control portion of the message specifying a message identifying number and by incorporating additional 25 selective call receiver functionality. When the selective call receiver recognizes that the informational portion of the emergency message is null or contains some preassigned, rarely used character or character string, the receiver 30 interprets this condition as an indicator to delete a previously stored message having the same message identifying number as that associated with the immediate deleting message.

Still further refinements can be made by 35 using another digit or character string in the

- 32 -

control portion of the message which specifies the amplitude, duration and pattern of the audio and visual annunciators of the receiver to convey the urgency of individual emergency messages.

5 A second important operating mode for the selective call emergency notification communications systems herein shown and described is (a) the delivery of control commands and messages to a remote location, (b) the correct routing to the
10 particular device required to receive the command or message, and © the combination of different technologies into special use receivers intended for use within the system. One such special use receiver is shown at 218 in FIG. 10 and functions to
15 forward emergency messages from one system to another paging system. In other words, the receiver 218 receives an emergency message from the selective call communications system of which it is a part, and, if appropriate instructions are received,
20 forwards the message on for reception by other receivers 220 that are part of a different selective call system.

 To accomplish this function, the special receiver 218 includes a repeating receiver media
25 interface. The receiver 218 receives any emergency message sent from one of the head end communications interfaces 202, but then strips off all additional sub-address information, thereby leaving the actual message. The actual message is then communicated to
30 another pager transmitter for broadcast to pagers that are not a part of the main system or included in the original subgroup of receivers. This feature allows any paging carrier to utilize messages originally sent in the first or host system even if
35 the frequency or signaling protocol is different

from the host system. Compatibility is thus assured.

5 A similar concept can be used to interface the system to other radio based systems such as all digital personal communications systems and other such specialized radio based systems such as IVDS (Interactive Video Data Systems).

10 Still another feature that can be implemented is the capability of linking with other local premise based transmitter devices such as baby monitors, telephone monitors and door bell ring detectors. These are particularly useful to the hearing impaired who cannot respond to ordinary sound-based signals. Such devices can be linked to
15 a transmitter that generates a signal received by one of the receivers 208. Previously encoded messages are sent by the transmitter in response to receipt of an appropriate signal from the detector and are sent to the appropriate receiver 208 where
20 they are decoded. The receiver 208 then generates an appropriate display to alert the user. This feature can be incorporated into a special selective call repeater system consisting of a selective call receiver that responds to two sources of selective
25 call signals where one source is the emergency notification communications system and the other source is an on-site selective call system. The on-site selective call system responds to door bell, telephone and other common household activities or
30 sounds and includes a low power transmitter. The two-source selective call receiver generally uses a vibrating alarm indicator to aid persons who cannot hear sound-based warnings, signals or messages.

35 Still another feature that can be implemented is a roving receiver 222 capable of

receiving localized messages while moving within or through an affected space or area. Such a receiver 222 can be equipped, for example, with a global positioning system (GPS) receiver 224 that monitors the geographical position of the receiver 222 and supplies positioning information that can be used by appropriate circuitry within the receiver 222 to determine whether the receiver is within the geographic area specified by the message originator and encoded into the signal broadcast by the transmitter 204. If the receiver 222 is within the specified geographic area, the message is displayed. If it is not, the message is ignored. This feature can be implemented over a very wide area such as the entire United States by monitoring selected CAP (variously, Code Assignment Plan or Capture) codes. These codes can be operated by using another receiver 208 in the system that strips off any other sub-address information, but only sends out the desired geographical information (i.e., latitude and longitude) along with the main message. The roving receiver 208, upon receiving the appropriate capture code and verifying presence within the intended geographic area, would then strip off the location grid information and only display the desired message.

Another pager-based, "one way broadcast" communications system 300 is shown in FIG. 12. In this system, the transmitting devices, i.e., the head end communications interface 12, the head end media interface 14, the telephone network 18 and the paging network 20 are as previously described. The remote media interface gateway or receiver 302, however, is different.

The receiver 302 used in the system 300 is

adapted to remain operational in the event utility based power is lost. Such power failures are not uncommon when emergencies or natural disasters occur. To avoid losing the capability of receiving emergency messages just at the time communication is most important, the receiver 302 includes an internal battery 304 that automatically switches in to supply operating power in the event line current is lost.

As illustrated, power for the receiver 302 is ordinarily provided by a power supply 306 operating from ordinary 120 VAC current. Preferably, the receiver 302 comprises a self contained unit that "plugs into" a standard, residential 120 VAC outlet. The power supply 306 rectifies, filters and regulates the incoming power in known manner to supply the requisite operating voltage and current to the various receiver 302 sub-circuits. In the event line current is lost, the battery 304 automatically switches in to continue powering the receiver 302.

The battery 302 is kept at full charge by means of a charger 308 that operates from the 120 VAC line source. The charger 308 supplies current to the battery 302 as needed to keep the battery 302 at full charge. In the event of a power failure, the battery thus operates the receiver 302 beginning with a full charge.

The receiver 302 contains a message display 30 and a wireless receiver 36 that can be the same as or similar to these respective elements of the previously described receiver or remote media interface gateway 16. In addition, the receiver 302 includes a plurality of light emitting diodes (LEDs) 310, an audible alarm or transducer 312 and a

plurality of control buttons 314 that enable the user to control the operation of the receiver 302. Each of these elements is coupled to a control microprocessor 316 that controls the overall operation of the receiver 302 and that can be programmed in a variety of ways to achieve various desired results. Depending upon how the control microprocessor 316 is programmed, a variety of various, specialized receivers can be realized.

5
10
15
20
25
30
35

One such specialized receiver that can be used as part of the systems herein described is a combination receiver and rechargeable battery-powered flashlight 226 (FIG. 10) This device 226 would normally be plugged into a standard 120 VAC outlet or source for continued powering, but would also operate from a self contained rechargeable battery kept charged by a self contained battery charger. In addition to the capabilities of the standard receivers 208, the receiver 226 would also contain a battery source and a light source, such as an illuminating lamp or high intensity light emitting diode. Another feature that can be advantageously included is the ability to provide a rapid flashing signal using a momentary on/off button that would also extend battery charge life by minimizing extended operation. On important aspect of the receiver 226 is the dual powering function wherein the receiver 226 is powered in a normal operating mode from a 120 VAC outlet. The receiver 226 is designed to remain plugged into the wall outlet during normal use. The internal battery allows the receiver to remain operational in the event of a power failures that frequently occur as a consequence of emergency or natural disaster conditions. The light source incorporated into the

receiver can be used for emergency lighting. Additionally, the receiver 226 can be operated from the battery of a vehicle to permit mobile operation or can be worn on a belt to permit personal, mobile
5 operation.

Other such specialized receivers could incorporate smoke alarm, carbon monoxide detectors or other human and property safety devices into a common unit.

10 Still further benefits may be realized by incorporating two-way signaling devices and protocols so as to automatically notify a "911" or other emergency center of a fire or other hazardous condition at the earliest possible time or when
15 occupants of a site are absent or unconscious.

Although the invention has been shown and described in its preferred form using a wireless communications system such as a paging system, it will be appreciated that the invention is not
20 limited in its broader aspects to paging systems or even to wireless communications systems. For example, the invention can also be used in connection with alternative forms of communication and message delivery such as wireless telephones,
25 the internet, hardwired computer systems, television or other broadcast receivers or combinations of such devices.

While a particular embodiment of the invention has been shown and described, it will be
30 obvious to those skilled in the art that changes and modifications can be made without departing from the invention in its broader aspects, and, therefore, the aim in the appended claims is to cover all such changes and modifications as fall within the true
35 spirit and scope of the invention.

CLAIMS:

1. A method of operating a wireless system so as to communicate messages to specific groups among a plurality of potential message recipients according to the presence or absence of the potential message recipients within a specified geographic area, comprising the steps of:

5 equipping each of the potential message recipients with a wireless receiver operable to receive encoded geographic coordinates and to determine presence or absence within an area defined by the received encoded geographic coordinates;

10 identifying the geographic coordinates defining the specific geographic area to which the group specific message is directed,

15 transmitting to each of the receivers a message containing an informational portion and a portion containing the geographical coordinates of the specified geographic area,

20 determining at each of the receivers presence or absence within the specified geographic area, and

displaying the informational portion of the message at the receivers determined to be within the specified geographic area.

2. A method of operating a pager-based communications system having a plurality of receivers each responsive to a common base address and to a unique individual address, comprising the steps of:

5 generating for each of the receivers a unique identification code;

locating each of the receivers at a specific geographic location;

10 generating for each of the receivers a

location code indicative of the specific geographic location associated with the receiver; and

communicating via a wireless communications link the unique identification code and the location code to respective ones of the receivers.

3. A method as defined in claim 3 comprising the further steps of:

relocating a receiver to a different geographic location;

generating a new location code indicative of the receiver's different geographic location; and communicating via a wireless communications link the new location to the relocated receiver.

4. A method of operating a wireless system so as to communicate group specific messages to specific groups among a plurality of potential message recipients, comprising the steps of:

identifying specific groups among the plurality of potential message recipients;

assigning to each of the identified specific groups a group specific address;

equipping each of the potential message recipients with a wireless receiver responsive to the group specific address of the specific group to which the potential message recipient belongs;

generating a message containing an informational portion and an address portion, the address portion including the group specific address of the specific group intended to receive the message;

transmitting via a wireless signal the message over a geographic area containing the potential message recipients so that the receivers responsive to the group specific address will accept the message and communicate the informational

- 40 -

portion of the message to the member of the specific group; and

25 verifying the existence of authority to transmit the message to the specific group before transmitting the message to the specific group.

5 5. A method of operating a wireless paging system so as to communicate group specific time sensitive messages to specific groups among a plurality of potential message recipients, comprising the steps of:

 identifying specific groups among the plurality of potential message recipients;

 assigning to each of the identified specific groups a group specific address;

10 equipping each of the potential message recipients with a wireless receiver responsive to the group specific address of the specific group to which the potential message recipient belongs;

15 generating a message containing an informational portion, an address portion, and a time duration portion, the address portion including the group specific address of the specific group intended to receive the message;

20 transmitting via a wireless signal the message over a geographic area containing the potential message recipients so that the receivers responsive to the group specific address will accept the message and communicate the informational portion of the message to the member of the specific group;

25 decoding the time duration portion of the message to define a time period; and

 deleting the informational portion of the message following expiration of the time period.

6. A method as defined in claim 5

- 41 -

comprising the further step of resetting each of the receivers following expiration of a predetermined time interval.

7. A receiver unit for use in a pager-based communications system operable to direct messages to specific groups of pagers within a larger group of receivers within the service area of
5 the system comprising:

a wireless receiver responsive to a base address;

a decoder coupled to the wireless receiver for recognizing a group-identifying indicator
10 indicative of inclusion within the specific group;

an audible alarm annunciator responsive to the wireless receiver and the decoder for sounding an audible alarm in the event of receipt of an alarm message directed to the receiver unit; and

15 control circuitry for silencing the audible alarm after passage of a predetermined time period following receipt of the alarm message.

8. A receiver unit as defined in claim 7 wherein the control circuitry is further operable to reduce the audio level of the audible alarm in response to appropriate control signals received
5 from the wireless receiver.

9. A method of operating a pager-based communications system comprising the steps of:

generating a message having a base address portion, a control instruction portion and an
5 informational portion;

transmitting the message via a wireless signal;

receiving the transmitted message on a receiving unit operable to respond to messages
10 containing the base address;

decoding the control instruction portion of the message and, in response to receipt of an appropriate decoded control instruction, thereafter transferring the informational portion of the message to a different paging system for distribution over the different paging system.

15
10
5
the system comprising:

a wireless receiver responsive to a base address;

a decoder coupled to the wireless receiver for recognizing a group-identifying indicator indicative of inclusion within the specific group;

10
an audible alarm annunciator responsive to the wireless receiver and the decoder for sounding an audible alarm in the event of receipt of an alarm message directed to the receiver unit; and

15
control circuitry for silencing the audible alarm after passage of a predetermined time period following receipt of the alarm message.

11. A receiver unit for use in a pager-based communications system operable to direct messages to specific groups of pagers within a larger group of receivers within the service area of the system comprising:

5
a wireless receiver responsive to a base address;

a decoder coupled to the wireless receiver for recognizing a group-identifying indicator indicative of inclusion within the specific group;

10
circuitry coupled to the decoder and the wireless receiver for recognizing an informational

portion of a message directed to the specific group of receivers, and

15 additional circuitry responsive to an informational input received independently of the message directed to the specific group of receivers.

12. A receiver unit as defined in claim 11 wherein the informational input comprises a signal indicative of the geographic location of the receiver unit.

13. A receiver unit as defined in claim 12 wherein the informational input is obtained from a global positioning system receiver.

14. A receiver unit as defined in claim 11 wherein the informational input is derived from a sensor located in the vicinity of the receiver unit.

15. A receiver unit as defined in claim 14 wherein the sensor is selected from the group consisting of baby monitors, telephone monitors and door bell ring detectors.

16. A receiver unit as defined in claim 11 further comprising a memory for storing one or more previously recorded messages and a display for displaying the previously recorded message in response to receipt of an appropriate informational input.

17. A receiver unit as defined in claim 11 further comprising a non-aural based indicator for indicating receipt of an informational input.

18. A receiver unit as defined in claim 11 further comprising an alternate source of operating energy.

19. A receiver unit as defined in claim 18 wherein the alternate source comprises a battery-operated power supply.

20. A receiver unit as defined in claim 19

further comprising a light source actuated upon actuation of the alternate source.

21. A method of operating a communications system comprising the steps of:

generating a message having a base address portion, a control instruction portion and an informational portion;

transmitting the message via a signal;

receiving the transmitted message on a receiving unit operable to respond to messages containing the base address; and

decoding the control instruction portion of the message and, in response to receipt of an appropriate decoded control instruction, cancelling a previously received message.

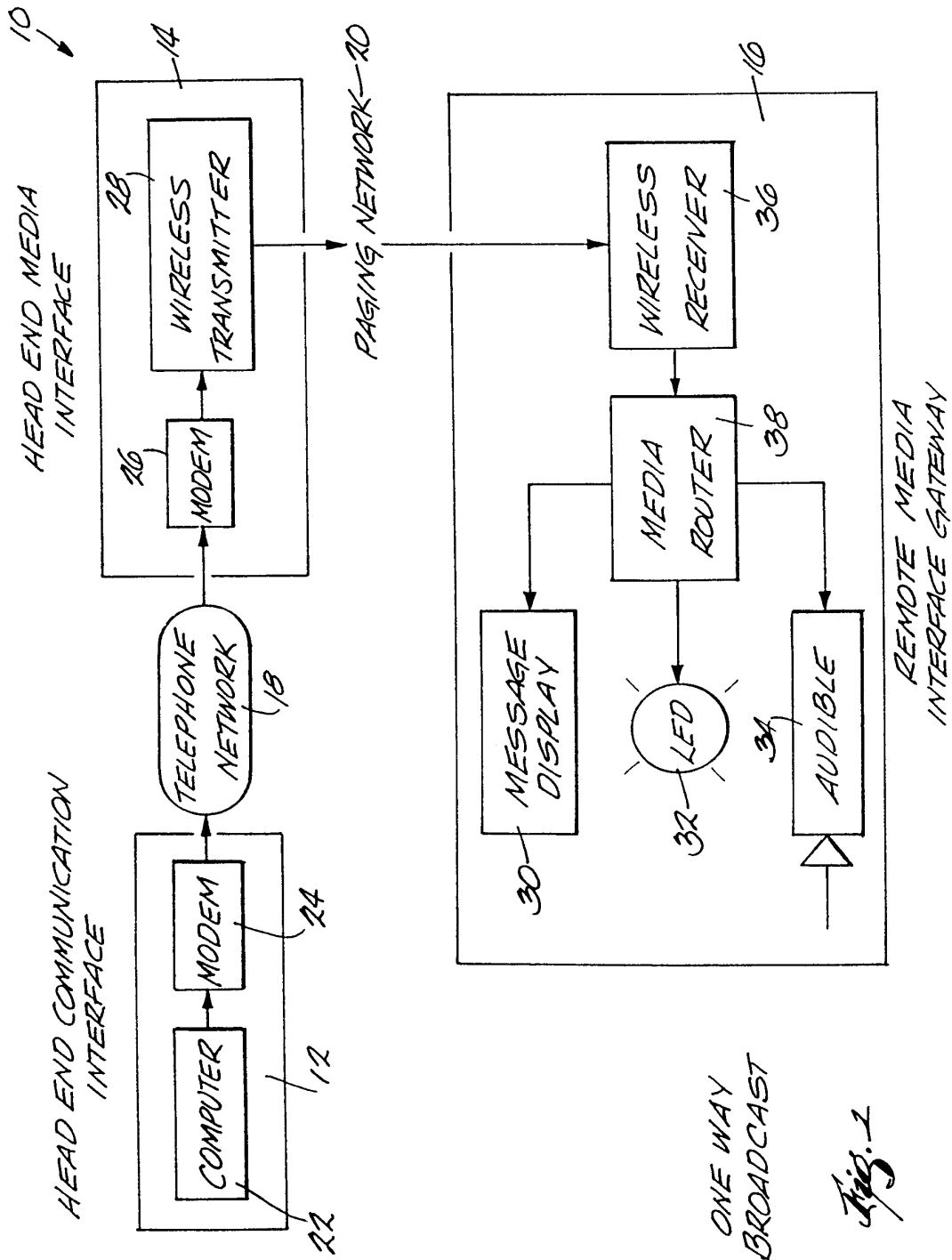

SUBSTITUTE SHEET (rule 26)

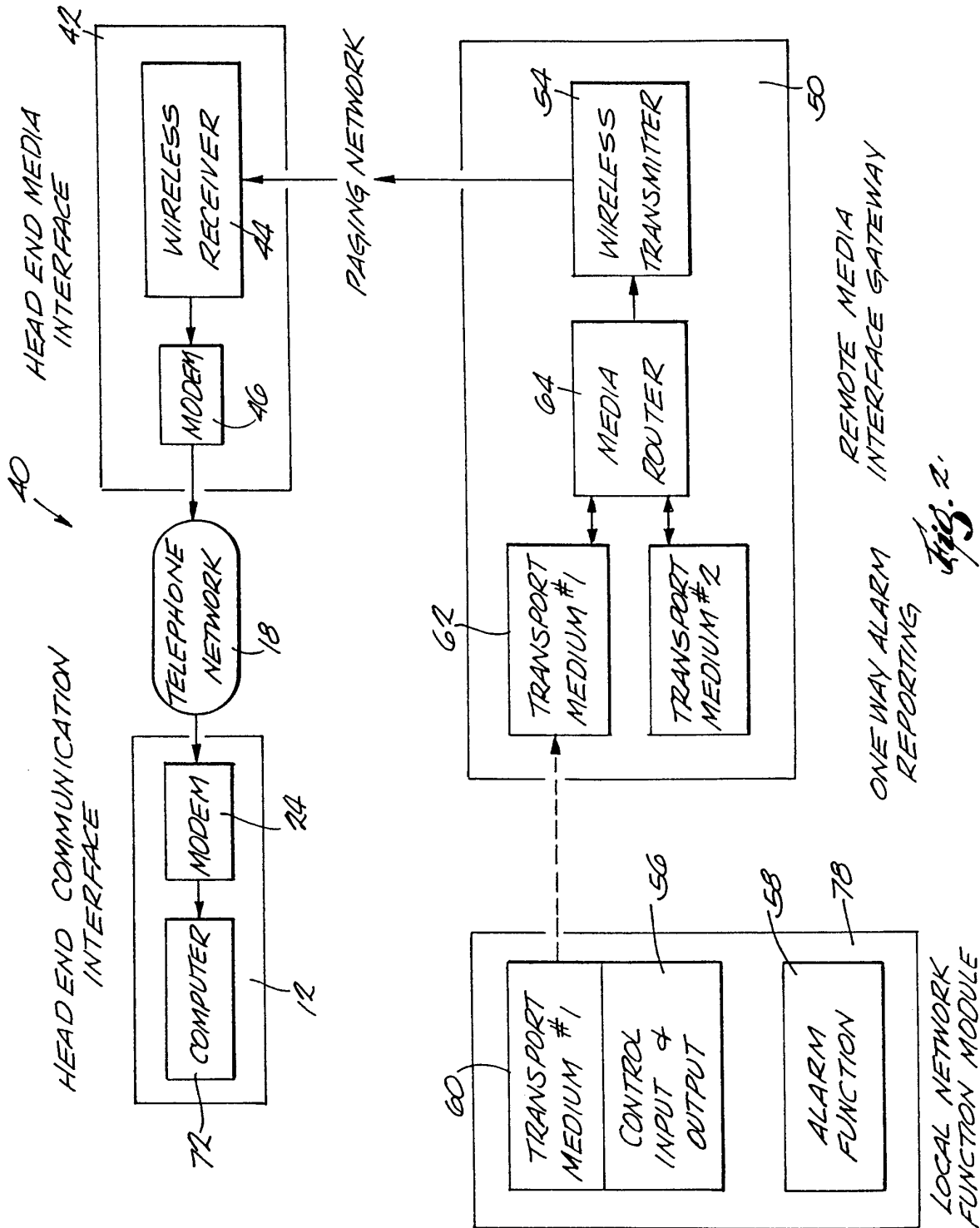

Fig. 2.

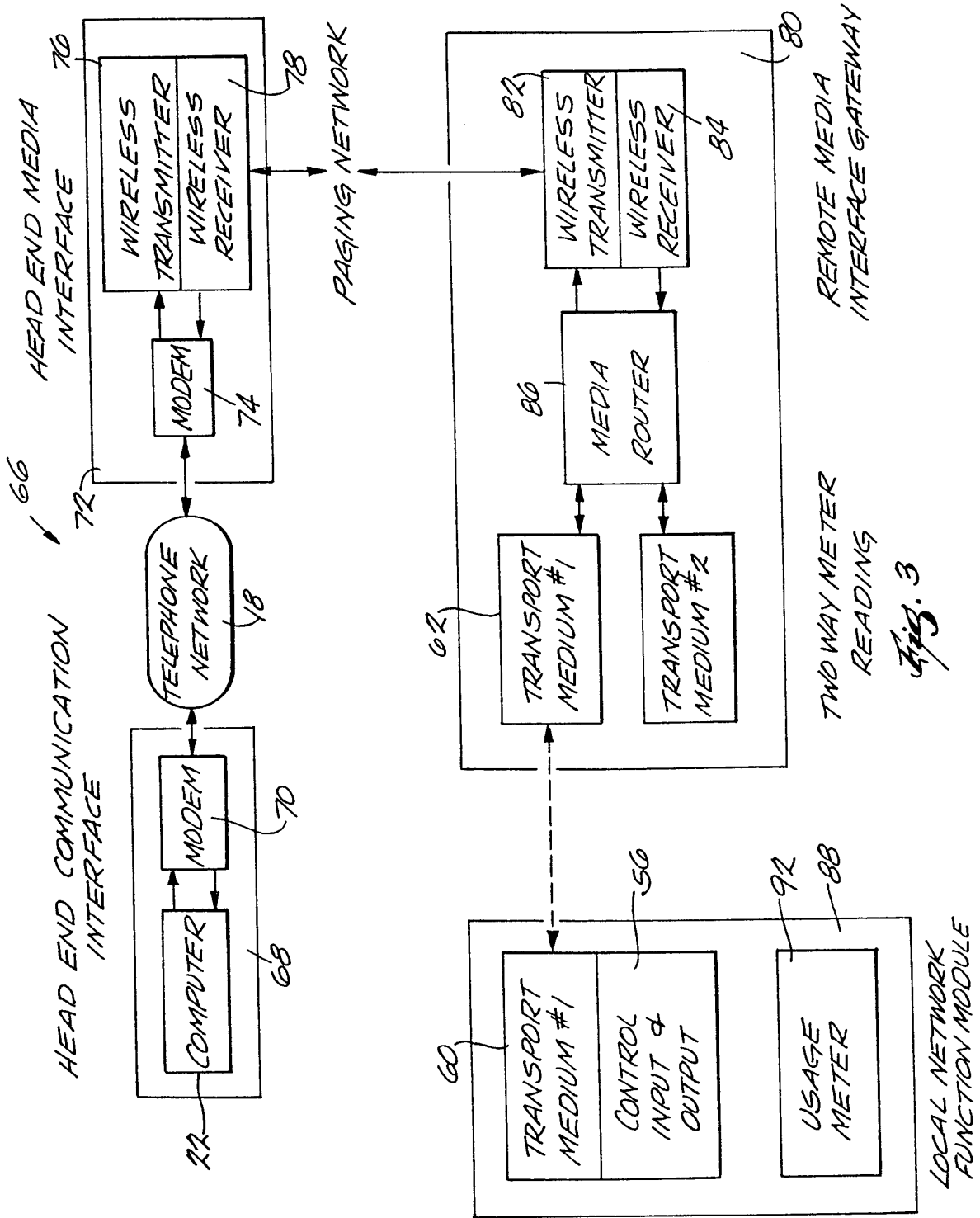

Fig. 3

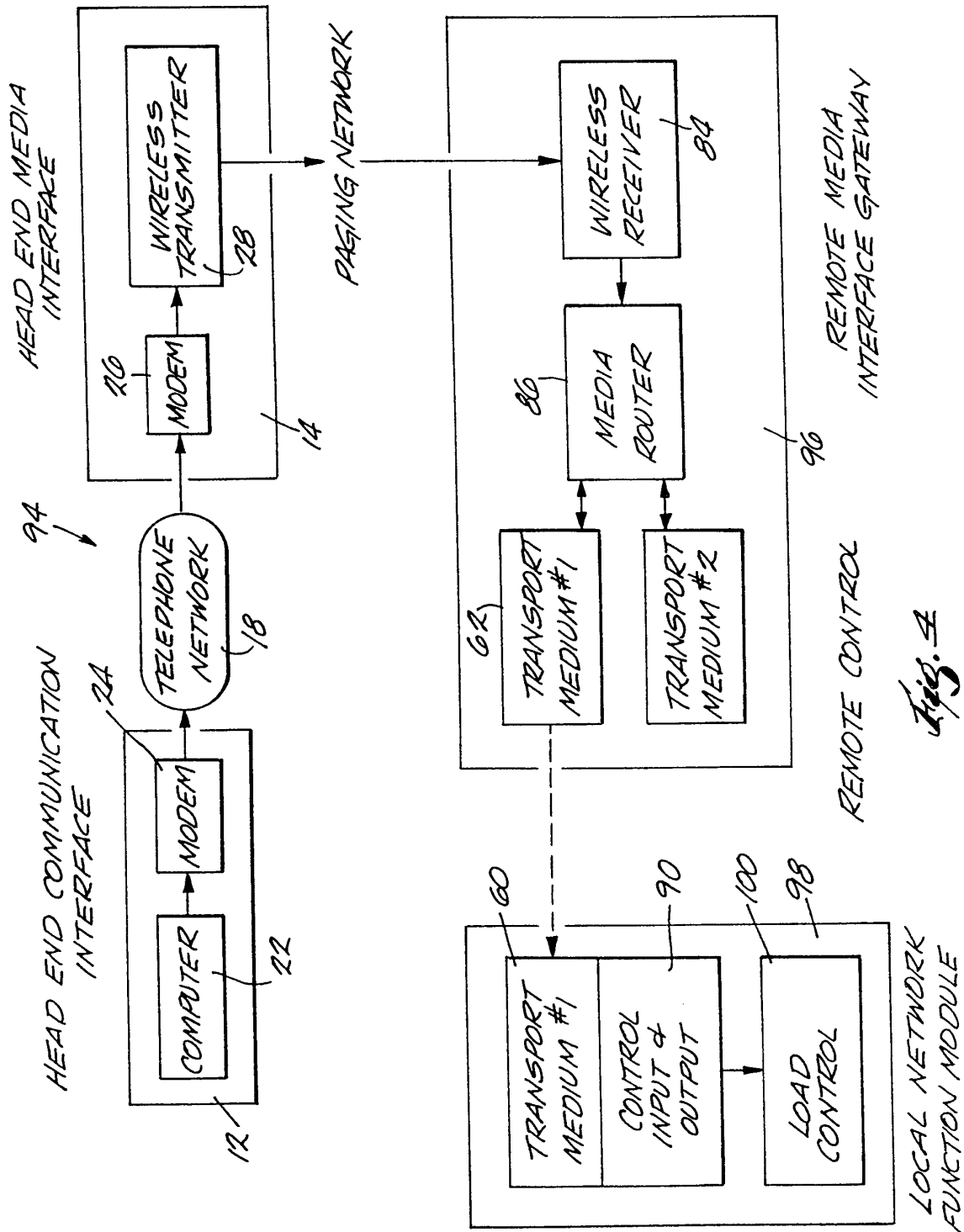
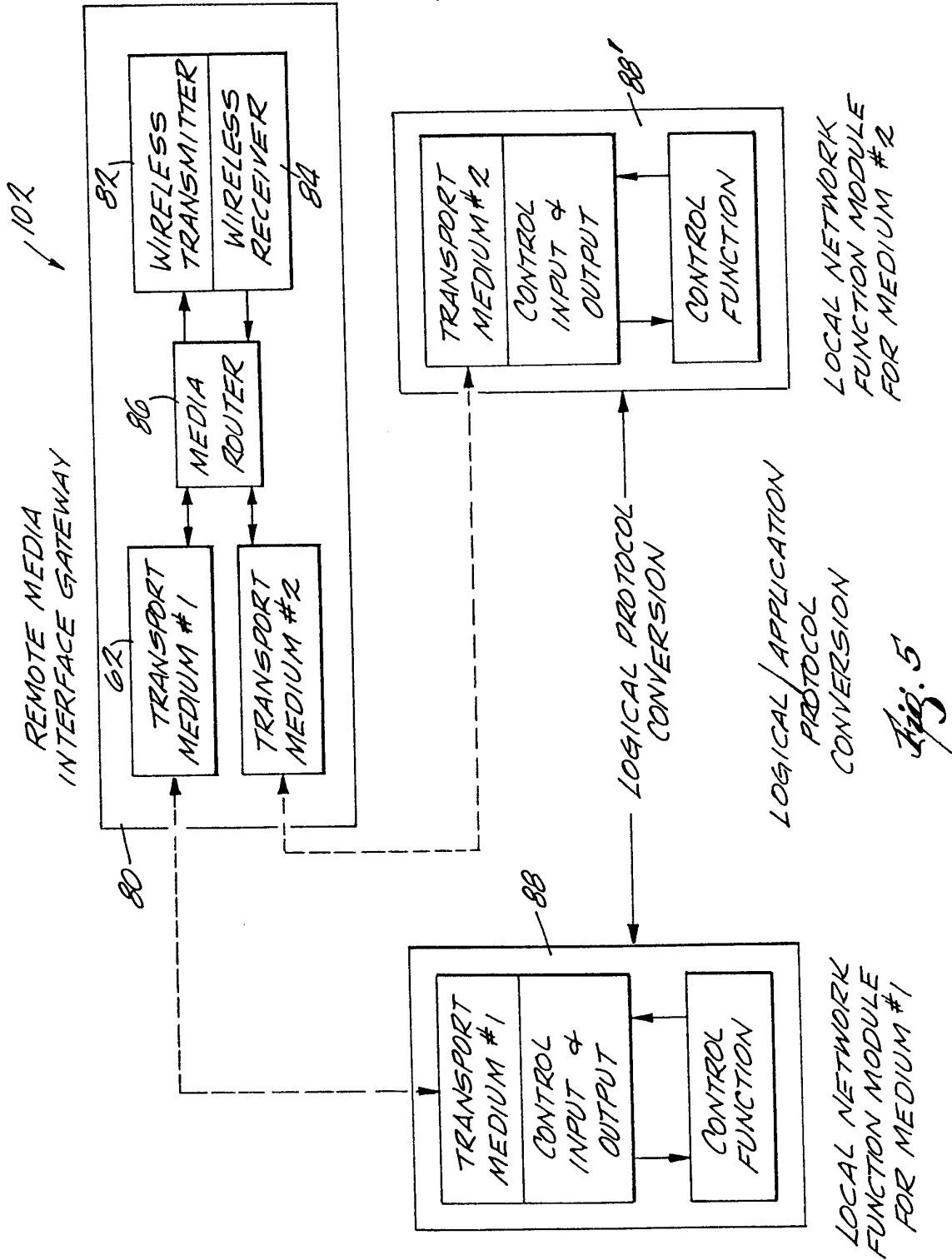
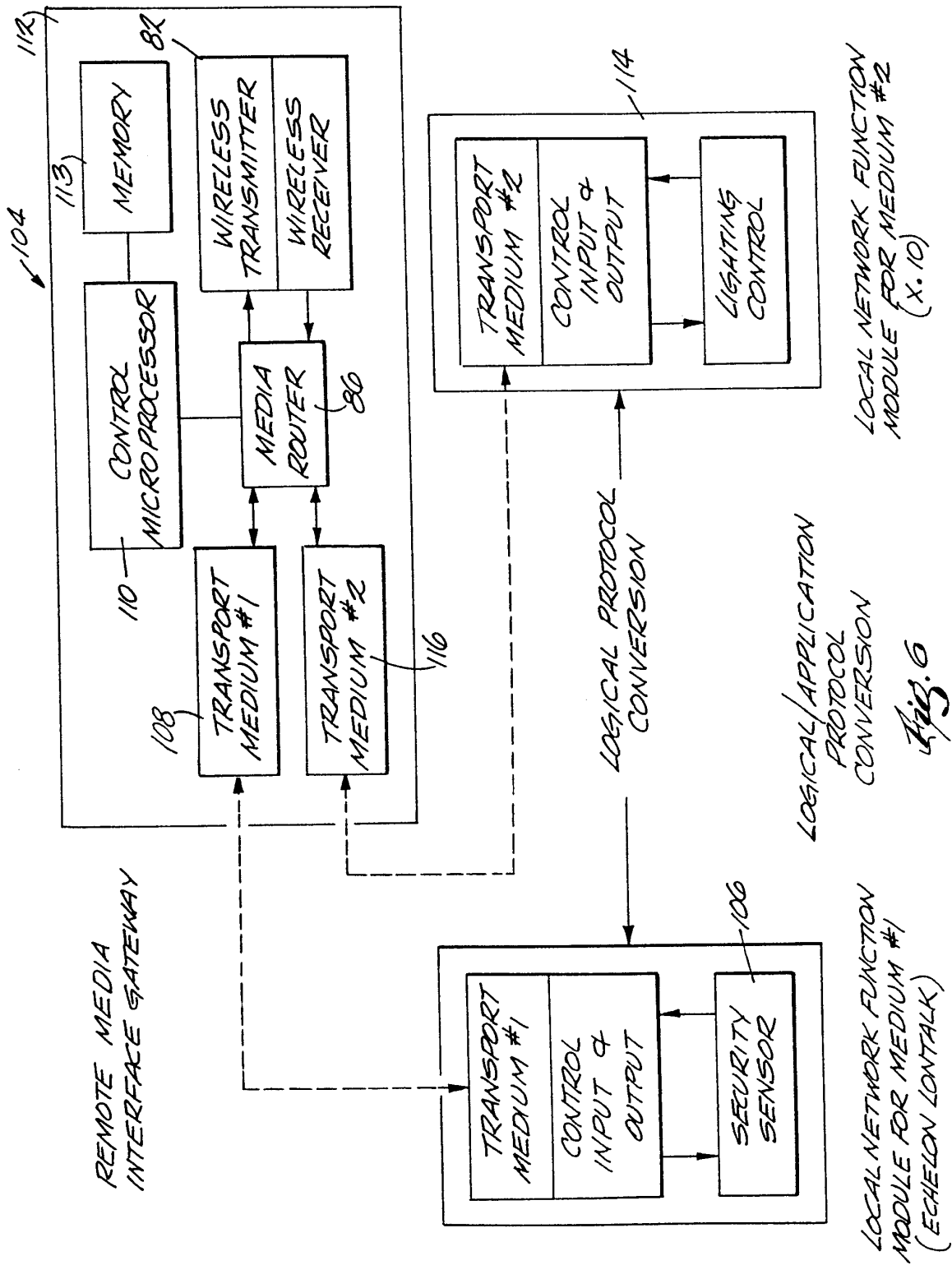

Fig. 4





REMOTE MEDIA INTERFACE GATEWAY

LOCAL NETWORK FUNCTION MODULE FOR MEDIUM #2 (X.10)

LOGICAL/APPLICATION PROTOCOL CONVERSION

Fig. 6

LOCAL NETWORK FUNCTION MODULE FOR MEDIUM #1 (ECHELON LONTALK)

7/11

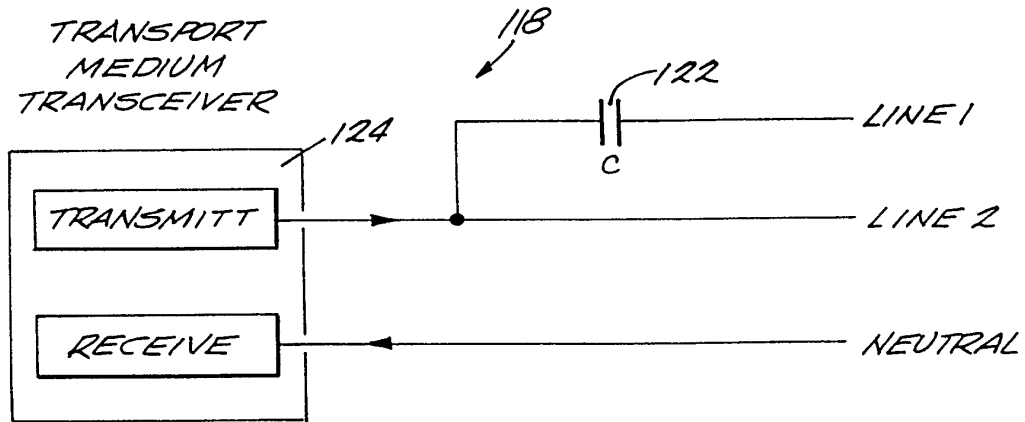

LINE 1- LINE 2 TO NEUTRAL CONNECTION

Fig. 7

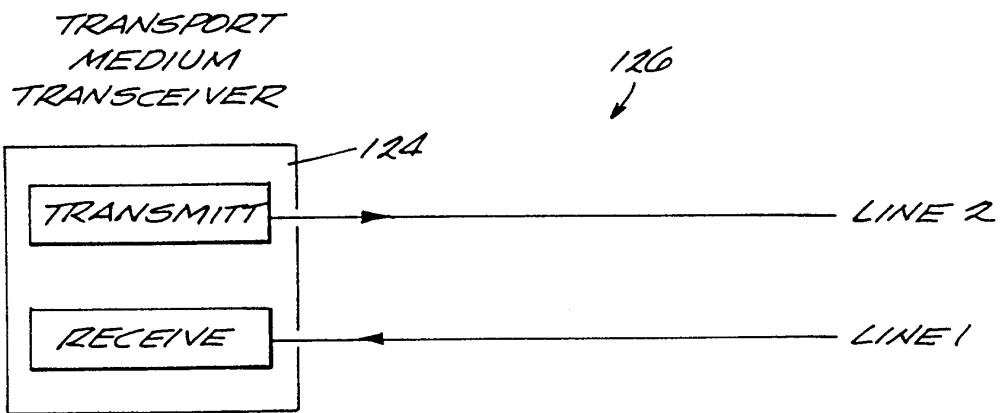

LINE 1 TO LINE 2 CONNECTION

Fig. 8

SUBSTITUTE SHEET (rule 26)

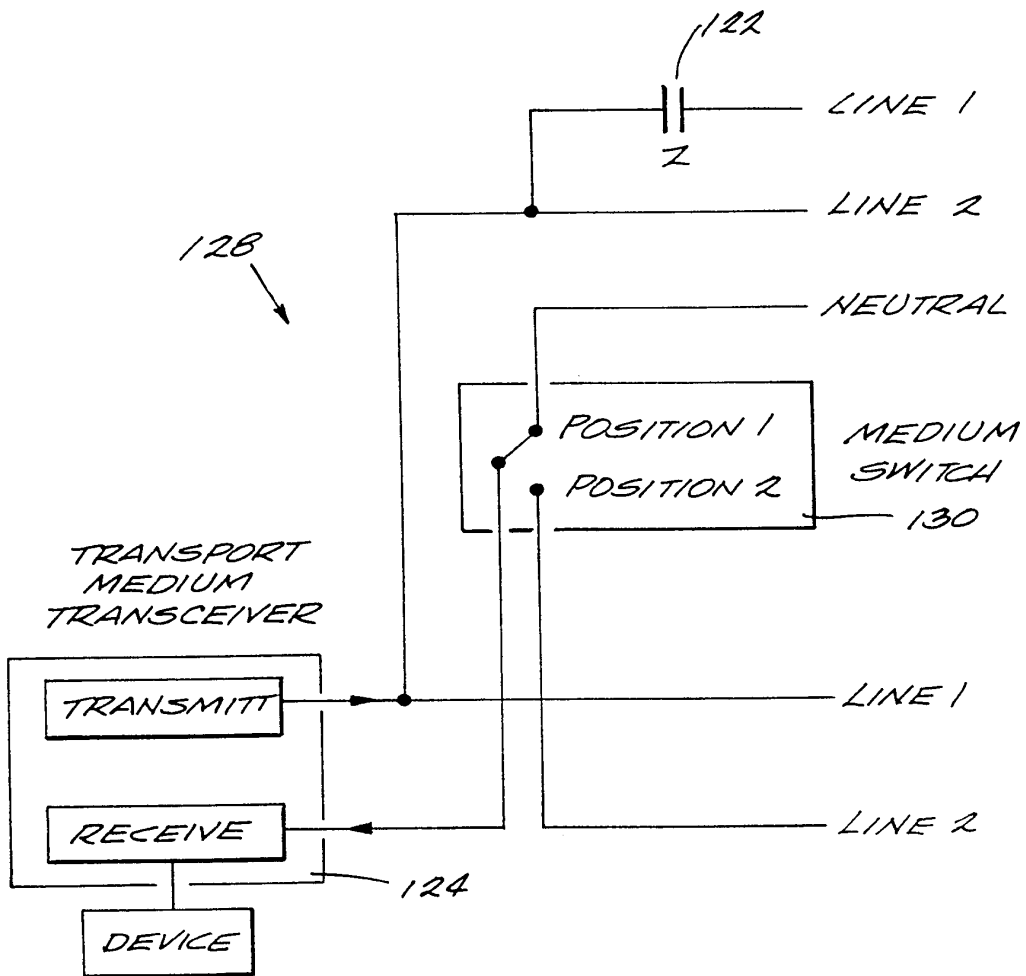

LINE 1- LINE 2 TO NEUTRAL CONNECTION
LINE 1 TO LINE 2 CONNECTION

Fig. 9

9/11

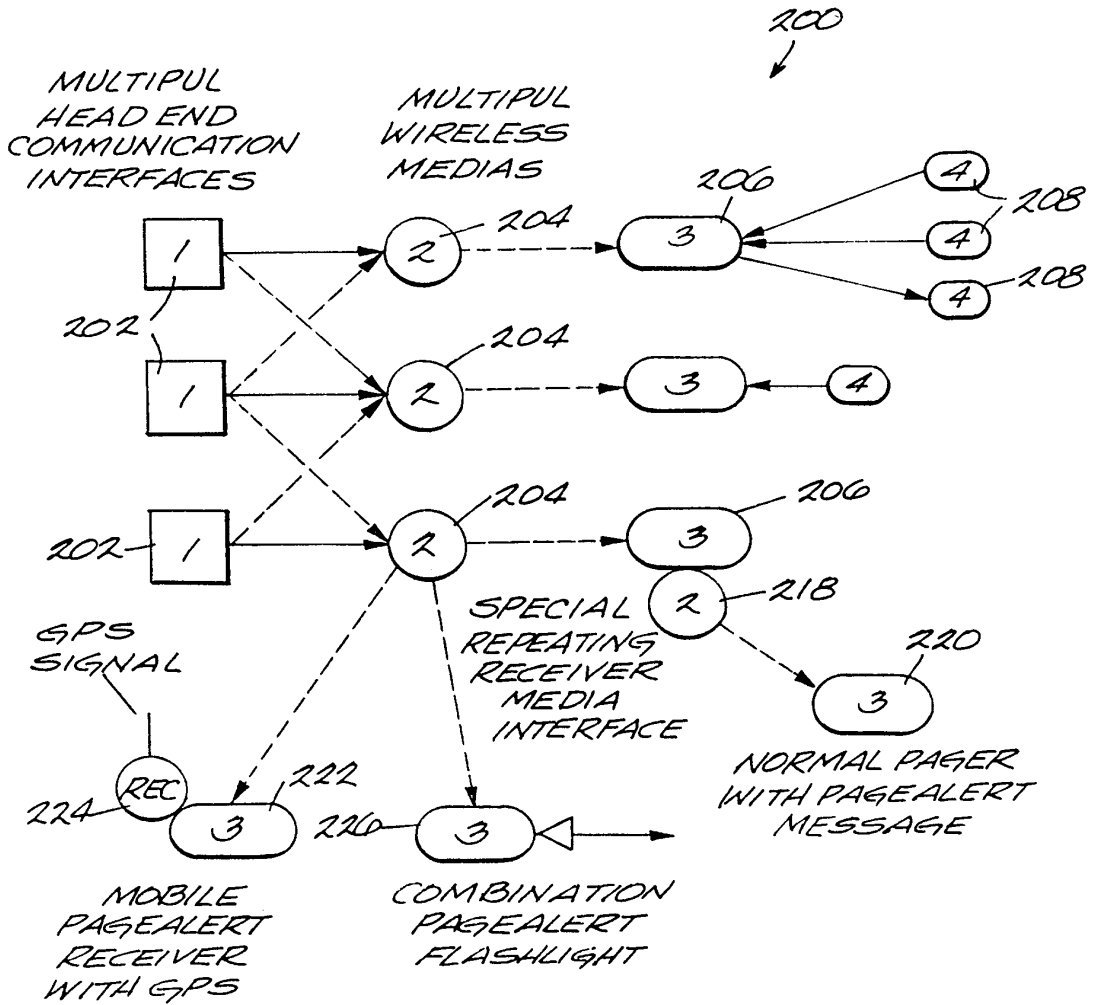

Fig. 10

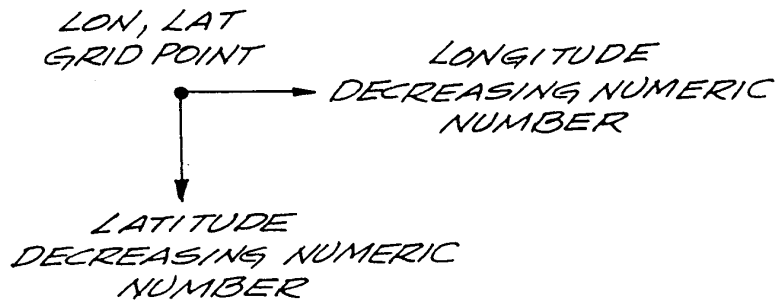
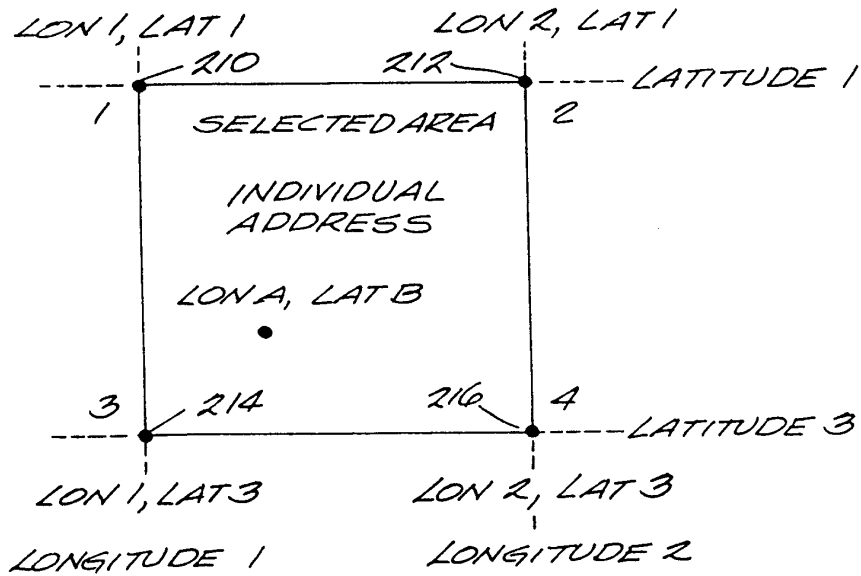
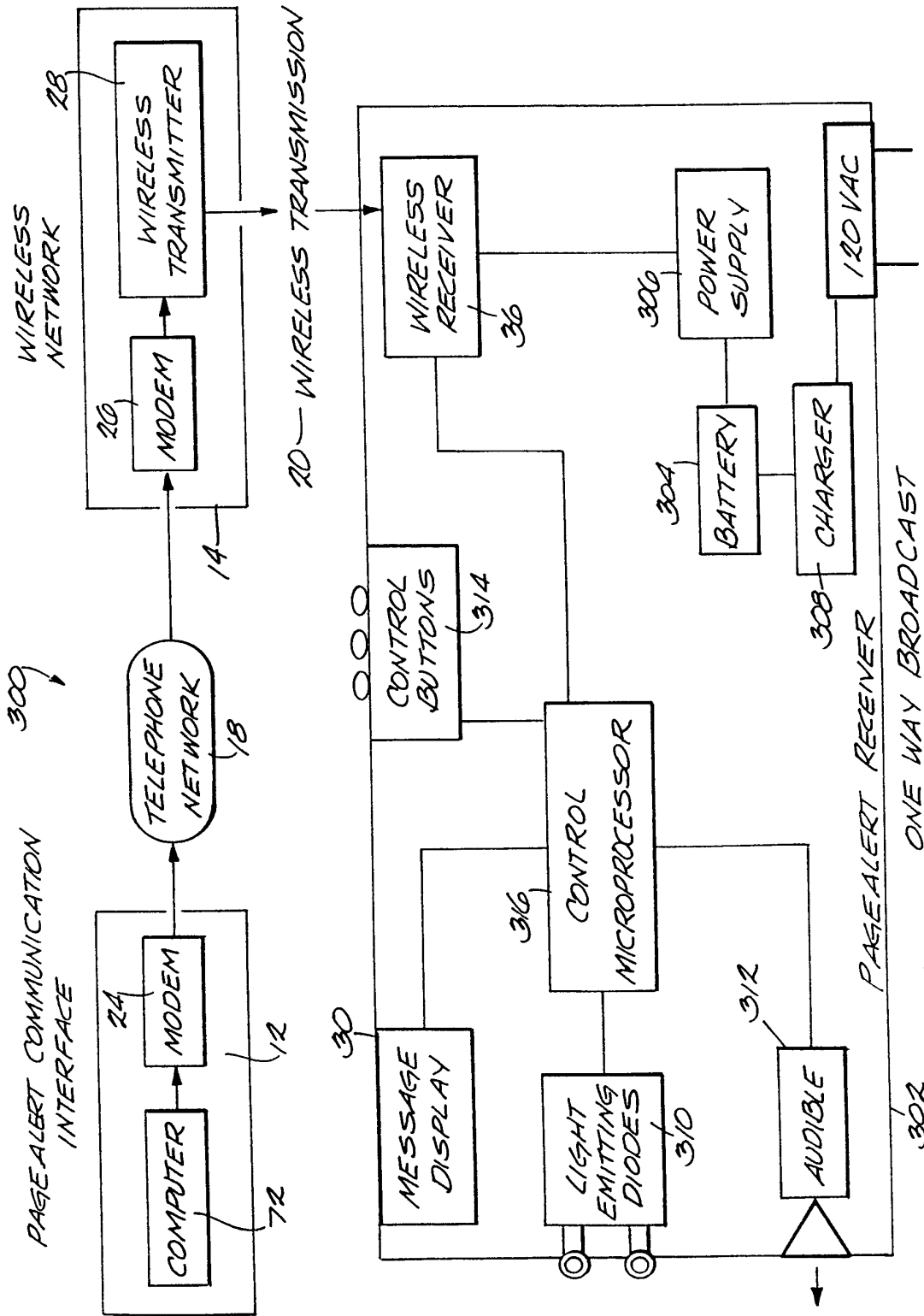

Fig. 11



SUBSTITUTE SHEET (rule 26)

INTERNATIONAL SEARCH REPORT

International application No.
PCT/US98/08333

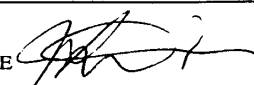
A. CLASSIFICATION OF SUBJECT MATTER		
IPC(6) : G08B 5/22, 13/19; H04Q 1/00, 7/00; H04B 1/16 US CL : 340/825.44, 825.52; 455/58 According to International Patent Classification (IPC) or to both national classification and IPC		
B. FIELDS SEARCHED		
Minimum documentation searched (classification system followed by classification symbols) U.S. : 340/825.44, 825.52; 455/58		
Documentation searched other than minimum documentation to the extent that such documents are included in the fields searched NONE		
Electronic data base consulted during the international search (name of data base and, where practicable, search terms used) Aps Search terms: emergency, wireless, select?, group#, message#, recipient#, transmit?, receiv?, locat?, geographic, area#		
C. DOCUMENTS CONSIDERED TO BE RELEVANT		
Category*	Citation of document, with indication, where appropriate, of the relevant passages	Relevant to claim No.
Y	US 5,077,830A (MALLIA) 31 December 1991, abstract, col 1 lines 22 - 26, col 2 lines 48 - 59, paragraph bridging col 3 and 4, col 4 lines 56 through col 5 lines 4, col 5 lines 5 - 14, figs. 1, 2, 4B.	1 - 6, 9, 12, 13, 21
X, P ----- Y	US 5,635,914A (PETREYE et al.) 3 June 1997, figs. 1, 2, 11, 19, paragraph bridging col 12 and 13, col 14 lines 25 - 28, col 16 lines 33 - 37.	8, 10, 11, 17 - 20 ----- 1 - 7, 9, 14 - 16, 21
Y	US 5,381,133A (ERHART et al.) 10 January 1995, figs. 6 and 7, paragraph bridging col 6 and 7.	6
<input checked="" type="checkbox"/> Further documents are listed in the continuation of Box C. <input type="checkbox"/> See patent family annex.		
* Special categories of cited documents:	"T" later document published after the international filing date or priority date and not in conflict with the application but cited to understand the principle or theory underlying the invention	
"A" document defining the general state of the art which is not considered to be of particular relevance	"X" document of particular relevance; the claimed invention cannot be considered novel or cannot be considered to involve an inventive step when the document is taken alone	
"E" earlier document published on or after the international filing date	"Y" document of particular relevance; the claimed invention cannot be considered to involve an inventive step when the document is combined with one or more other such documents, such combination being obvious to a person skilled in the art	
"L" document which may throw doubts on priority claim(s) or which is cited to establish the publication date of another citation or other special reason (as specified)	"&" document member of the same patent family	
"O" document referring to an oral disclosure, use, exhibition or other means		
"P" document published prior to the international filing date but later than the priority date claimed		
Date of the actual completion of the international search 23 JUNE 1998	Date of mailing of the international search report 09 OCT 1998	
Name and mailing address of the ISA/US Commissioner of Patents and Trademarks Box PCT Washington, D.C. 20231 Facsimile No. (703) 305-3230	Authorized officer JEAN JEANGLAUDE  Telephone No. 703 - 305 - 2701	

INTERNATIONAL SEARCH REPORT

International application No.
PCT/US98/08333

C (Continuation). DOCUMENTS CONSIDERED TO BE RELEVANT		
Category*	Citation of document, with indication, where appropriate, of the relevant passages	Relevant to claim No.
Y	US 4,894,649A (DAVIS) 16 January 1990, col 3 lines 25 - 32.	7
X	US 4,891,638A (DAVIS) 2 January 1990, abstract, fig. 2, fig. 3(A-B).	12, 13
Y	US 5,570,079A (DOCKERY) 29 October 1996, abstract, fig. 1.	14, 15
Y	US 5,459,458A (RICHARDSON et al.) 17 October 1995, fig. 1, paragraph bridging col 11 and 12.	16

Form PCT/ISA/210 (continuation of second sheet)(July 1992)★

(12) INTERNATIONAL APPLICATION PUBLISHED UNDER THE PATENT COOPERATION TREATY (PCT)

(19) World Intellectual Property Organization
International Bureau



(43) International Publication Date
21 June 2001 (21.06.2001)

PCT

(10) International Publication Number
WO 01/45061 A2

- (51) International Patent Classification⁷: G07G
- (21) International Application Number: PCT/IB00/01872
- (22) International Filing Date:
14 December 2000 (14.12.2000)
- (25) Filing Language: English
- (26) Publication Language: English
- (30) Priority Data:
09/461.353 15 December 1999 (15.12.1999) US
- (71) Applicant: NOKIA CORPORATION [FI/FI]; Keilalahdentie 4, FIN-02150 Espoo (FI).
- (71) Applicant (for LC only): NOKIA INC. [US/US]; 6000 Connection Drive, Irving, TX 75039 (US).
- (72) Inventor: RISSANEN, Jussi; Pajalahdentie 6 A 18, FIN-00200 Helsinki (FI).
- (74) Agents: BRUNDIDGE, Carl, I. et al.; Antonelli, Terry, Stout & Kraus, LLP, Suite 1800, 1300 N. Seventeenth Street, Arlington, VA 22209 (US).
- (81) Designated States (national): AE, AG, AL, AM, AT, AU, AZ, BA, BB, BG, BR, BY, CA, CH, CN, CR, CU, CZ, DE, DK, DM, DZ, EE, ES, FI, GB, GD, GE, GH, GM, HR, HU, ID, IL, IN, IS, JP, KE, KG, KP, KR, KZ, LC, LK, LR, LS, LT, LU, LV, MA, MD, MG, MK, MN, MW, MX, NO, NZ, PL, PT, RO, RU, SD, SE, SG, SI, SK, SL, TJ, TM, TR, TT, TZ, UA, UG, UZ, VN, YU, ZA, ZW.
- (84) Designated States (regional): ARIPO patent (GH, GM, KE, LS, MW, MZ, SD, SL, SZ, TZ, UG, ZW), Eurasian patent (AM, AZ, BY, KG, KZ, MD, RU, TJ, TM), European patent (AT, BE, CH, CY, DE, DK, ES, FI, FR, GB, GR, IE, IT, LU, MC, NL, PT, SE, TR), OAPI patent (BF, BJ, CF, CG, CI, CM, GA, GN, GW, ML, MR, NE, SN, TD, TG).

Published:
— Without international search report and to be republished upon receipt of that report.

For two-letter codes and other abbreviations, refer to the "Guidance Notes on Codes and Abbreviations" appearing at the beginning of each regular issue of the PCT Gazette.



WO 01/45061 A2

(54) Title: WIRELESS ELECTRONIC COUPONING TECHNIQUE

(57) Abstract: An electronic couponing technique includes transferring coupon information, which may include a coupon ID (identification) to a first portable terminal and storing same therein. The portable terminal displays a representation of the transferred coupon information on a display thereof. The stored coupon information may be transferred from the portable terminal to another terminal for redemption. The stored coupon information may also be transferred from the portable terminal to another portable terminal. Various schemes may be used to transfer the coupon information including a Bluetooth low-range radio link or an optical bar code scanner scanning an optical bar code or an infrared link or a wireless link from the portable terminal. The Internet or wireless LAN (Local Area Network) may also be used in transferring the coupon information to and from the various terminals.

WIRELESS ELECTRONIC COUPONING TECHNIQUE**TECHNICAL FIELD**

The present invention relates to the field of telecommunications/mobile terminals. More particularly, the present invention relates to a mobile terminal capable of downloading, or scanning, or collecting, and viewing, or transmitting, and using coupons.

5 There has been a problem of how to handle transactions including coupons in retail stores. Coupons in a paper format require manual operation by the cashier at the retail store, taking up valuable customer service time, thus increasing the length of checkout lines, resulting in need of more personnel and thus expenses. Also the logistics involved in further mailing the paper coupons to respective manufacturers for validation and related cash
10 reimbursements to retail stores tie up significant amounts of effort and workload.

Also, at the customer end, there is the problem of how to keep track of, store, find and use the right coupons when visiting retail stores when buying the goods in question. Usually the coupon usage operation by the consumer has been as follows (an example):

15 A consumer reads a newspaper and finds a coupon insert. The consumer enters a retail store and collects the goods to be purchased. At the checkout counter, the goods are read by a bar code scanner. The consumer gives the cashier the coupons that are valid and the cashier enters the discount, either by bar code scanner or manually. The consumer thus receives a discount on the specific products mentioned in the coupons.

20 After that, the retail store gathers all the coupons, sorts them out and send them to their respective manufacturers who then credit the retail store's account on respective sums of the discount (in the case of manufacturer reimbursed coupons).

On the larger view there is a rising problem and challenge of how to bring meaningful and acceptable marketing communication, direct marketing, direct response

marketing and advertising messages to new wireless mobile terminals that are emerging. These wireless terminals include mobile phones, personal digital assistants (PDAs) with network connectivity, smart phones and other wireless internet appliances. The wireless couponing system, methodology and apparatus is a new method of providing advertisers and
5 marketers access to their target audiences using wireless terminals.

Presently, there are two types of Internet coupons in use in retail sales.

In one type of Internet coupon arrangement, Internet coupons are downloaded from the Internet by a user and printed on the user's printer. This eliminates the coupon distribution problem from the manufacturer or retail store to the user but does not eliminate
10 the use of paper coupons from the user to the retail store and optionally to the manufacturer.

Another type of Internet coupon arrangement allows the downloading of coupons from the Internet to a smart card of the user. The use of smart cards having coupons stored therein requires special hardware and the coupons stored in the smart card are not easily viewed by the user while in a retail store.

15 DISCLOSURE OF THE INVENTION

In carrying out one technique of the present invention, there is a system of infrastructure comprising and supporting wireless coupons that may be downloaded, viewed, credited (used) in electronic format throughout their distribution life cycle. The coupons are stored, carried and used in a wireless mobile terminal such as a mobile phone. The electronic
20 coupons may be delivered to the terminal by methods including: they may be downloaded to the terminal from the Internet; they may be pushed to the terminal by e-mail-type messages; they may be downloaded to the terminal by a short-range radio link such as Bluetooth or they may be scanned from a printed paper by using a (built in or external) scanner in a mobile terminal, or via an infrared link or by other methods. They may also be downloaded from a
25 wireless LAN connection.

An important distinction from previous Internet coupons and print coupons is the fact that the coupon files are stored in the memory of the mobile terminal, or a coupon ID number string is stored in the mobile terminal and the visual representation may be downloaded separately from a network server as needed or when excess bandwidth capacity exists. Thus, the coupon files are easily carried by the consumer at all times, and are readily available as the need rises (like when visiting a retail store, a restaurant, gas station, etc.). During a visit to a retail outlet, the consumer takes out his/her mobile terminal, initiates a coupon match sequence that compares the coupon files stored in the terminal with the promotions effective at the retail outlet. If a match is found, i.e., the consumer carries an electronic coupon that justifies a discount, the point of sale (POS) terminal calculates a discount to the prices of the goods to be purchased, or grants other specified benefits to the coupon bearer. The mobile terminal and the POS terminal may exchange the electronic coupon information in the following ways: a wireless digital short-range radio link such as Bluetooth, via an infrared data link, or via bar code scanning by the POS terminal from the mobile terminal display.

BRIEF DESCRIPTION OF THE DRAWINGS

The foregoing and a better understanding of the present invention will become apparent from the following detailed description of example embodiments and the claims when read in connection with the accompanying drawings, all forming a part of the disclosure of this invention. While the foregoing and following written and illustrated disclosure focuses on disclosing example embodiments of the invention, it should be clearly understood that the same is by way of illustration in example only and the invention is not limited thereto. The spirit and scope of the present invention are limited only by the terms of the appended claims.

Fig. 1 is a flowchart of a couponing system in accordance with the present invention.

Fig. 2 illustrates one possible implementation of coupon browsing on a wireless terminal.

Fig. 3 illustrates the general architecture of the wireless couponing technique of the present invention.

5 Fig. 4 illustrates the data flow from a wireless terminal to a point of sale terminal via Bluetooth.

Fig. 5 illustrates the data flow from a wireless terminal to a point of sale terminal via optical bar code scanning.

10 Fig. 6 illustrates the data flow from a wireless terminal to a point of sale terminal via an infrared link.

Fig. 7 illustrates the flow from a wireless terminal to a point of sale terminal via GPRS (general packet radio service).

Fig. 8 illustrates the data flow from a wireless terminal to a wireless terminal via GPRS.

15 Fig. 9 illustrates the data flow from a wireless terminal to a wireless terminal via an infrared link.

Fig. 10 illustrates the data flow from a wireless terminal to a wireless terminal via Bluetooth.

20 Fig. 11 illustrates the data flow from a wireless terminal to a wireless terminal utilizing optical bar code scanning.

Fig. 12 illustrates optically scanning a coupon ID from a print media source.

Fig. 13 illustrates a Bluetooth radio link transmitted coupon.

Fig. 14 illustrates a GPRS network transmitted coupon.

BEST MODE FOR CARRYING OUT THE INVENTION

25 Fig. 1 is a flowchart of a couponing system in accordance with the present invention.

In Step 100, a coupon is created and delivered to a network server. The various attributes of the coupon are inputted to the server by either a manufacturer of the product or products mentioned in the coupon or are inputted to the server from the offices of a retailer store. In both cases, the purpose of providing discount coupons is to increase sales by
5 providing the user with an additional incentive to purchase the product or products mentioned in the coupon. In the case of coupons being offered by a retailer, the incentive offered by the coupon increases the volume of traffic of potential buyers which usually results in increased sales.

In Step 110, the coupon is electronically delivered to the wireless terminal using one
10 of several optional methods which will be discussed later.

In Step 120, the terminal processes the electronically transmitted coupon by handling, categorizing, storing, and enabling browsing by the user.

Fig. 2 illustrates one possible implementation of coupon browsing on a display of a wireless terminal. This is but one possible example of the wireless terminal display during
15 coupon browsing. It is, of course, understood that other possibilities exist depending on the capability of the wireless terminal.

Returning to Fig. 1, in Step 130, the wireless terminal contains an additional feature not available with paper coupons, namely, the ability to forward the electronically transmitted coupon to another wireless terminal or to in effect multiply the electronically
20 transmitted coupon by forwarding it to several other wireless terminals. This allows for the wider distribution of the electronically transmitted coupon at no additional cost to the manufacturer or retailer issuing the coupon and is analogous to word-of-mouth advertising. Word-of-mouth advertising is a very powerful advertising tool in that a satisfied customer disseminates information about a product to other potential customers who value the opinion
25 of the satisfied customer.

In Step 140, the user of the billable terminal can transfer the electronically transmitted coupon to the point-of-sale terminal of the retailer via one of several different methods which will be discussed in detail later.

In Step 150, the point-of-sale terminal validates the electronically transmitted coupon and electronically redeems it by providing an immediate discount to the customer in accordance with the requirements of the coupon.

In Step 160, the point-of-sale terminal reports the redemption of the coupon to the issuer of the coupon such as the manufacturer in the case of manufacturer coupons and to the retailer's office in the case of retailer coupons.

Fig. 3 illustrates the general architecture of the wireless couponing technique of the present invention.

The coupon service server 200 receives and stores the attributes of the various coupons to be disseminated to the wireless terminals.

A coupon would include the discount/benefit information (e.g. which specific product, and which product family and in what combination, etc.), the forwardability and multiplyability information (that is, whether the electronic coupon could be forwarded to one or more other wireless terminals), the validity time period, the usage time period (e.g., during office hours, etc.). The textual and visual/audio representation of the coupon may be forwarded together or separately from the coupon service server, the coupons being identified by their coupon ID number.

In order to efficiently handle, classify, and store coupons, various metadata in a standardized format of the coupon is provided. One standardized format for the metadata could be XML (extended mark-up language).

Returning to Fig. 3, the coupon service server 200 transmits the coupon data through a firewall 210 to the Internet 220. The Internet 220 forward the data to a GGSN (gateway

GPRS (general packet radio service) support node) 230 which in turn transmits the data to a GPRS network operator 240.

The GPRS network operator 240 transmits the coupon data to an SGSN (serving GPRS support node) 250 which transmits the data via GPRS or 3G (third generation wireless communication) network 260, for example.

The network 260 transmits the data to wireless terminals 280 and 281 via BTS (base transceiver station) 270 and 271, respectively.

Alternatively, the coupon data can be transmitted only to wireless terminal 280 and then transmitted via various means which will be discussed subsequently to wireless terminal 281.

When the user of wireless terminal 281 wishes to redeem his or her electronic coupon at a retailer, the electronic coupon stored in his or her wireless terminal 281 is electronically transferred to the point-of-sale terminal 285 by various methods which will be discussed in detail later.

The redemption information contained in the point-of-sale terminal 285 is subsequently transferred to the retail chain corporate LAN (local area network) network 290 which compiles the coupon redemption information from all of its point-of-sale terminals and forwards this information to the coupon service server 200 via the firewall 295, Internet 220 and firewall 210.

Fig. 4 illustrates the data flow between a point-of-sale terminal and a wireless terminal via Bluetooth.

The following is a technology overview of the Bluetooth system.

The technology is an open specification for wireless communication of data and voice. It is based on a low-cost short-range radio link, built into a 9 x 9 mm microchip, facilitating protected ad hoc connections for stationary and mobile communication

environments. Bluetooth technology allows for the replacement of the many proprietary cables that connect one device to another with one universal short-range radio link. For instance, Bluetooth radio technology built into both the cellular telephone and the laptop would replace the cumbersome cable used today to connect a laptop to a cellular telephone.

5 Printers, PDA's, desktops, fax machines, keyboards, joysticks and virtually any other digital device can be part of the Bluetooth system. But beyond untethering devices by replacing the cables, Bluetooth radio technology provides a universal bridge to existing data networks, a peripheral interface, and a mechanism to form small private ad hoc groupings of connected devices away from fixed network infrastructures. Designed to operate in a noisy radio

10 frequency environment, the Bluetooth radio uses a fast acknowledgment and frequency hopping scheme to make the link robust. Bluetooth radio modules avoid interference from other signals by hopping to a new frequency after transmitting or receiving a packet. Compared with other systems operating in the same frequency band, the Bluetooth radio typically hops faster and uses shorter packets. This makes the Bluetooth radio more robust

15 than other systems. Short packages and fast hopping also limit the impact of domestic and professional microwave ovens. Use of Forward Error Correction (FEC) limits the impact of random noise on long-distance links. The encoding is optimized for an uncoordinated environment. Bluetooth radios operate in the unlicensed ISM band at 2.4 GHz. A frequency hop transceiver is applied to combat interference and fading. A shaped, binary FM

20 modulation is applied to minimize transceiver complexity. The gross data rate is 1Mb/s. A Time-Division Duplex scheme is used for full-duplex transmission. The Bluetooth baseband protocol is a combination of circuit and packet switching. Slots can be reserved for synchronous packets. Each packet is transmitted in a different hop frequency. A packet nominally covers a single slot, but can be extended to cover up to five slots. Bluetooth can

25 support an asynchronous data channel, up to three simultaneous synchronous voice channels,

or a channel which simultaneously supports asynchronous data and synchronous voice. Each voice channel supports 64 kb/s synchronous (voice) link. The asynchronous channel can support an asymmetric link of maximally 721 Kb/s in either direction while permitting 57.6 Kb/s in the return direction, or a 432.6 Kb/s symmetric link.

5 While Bluetooth has been discussed in detail above with regard to the present invention, it is to be understood that this is just for explanatory purposes. The present invention is not limited to the Bluetooth implementation.

 In operation, the wireless terminal 281 transmits the coupon ID and information to the point-of-sale terminal 285. The retail chain corporate LAN network 290, connected to
10 the coupon service server 200 via the firewall 210, Internet 220, and firewall 295, verifies the coupon and calculates the discount/benefit in real time or as a batch daily. The coupon information is updated to the coupon service server as well as to the retail chain network server.

 Fig. 5 illustrates the data flow from a wireless terminal to point-of-sale terminal via
15 optical bar codes.

 In operation, the wireless terminal 281 displays an optical bar code 288 containing coupon ID information on the screen of the wireless terminal 281. The point-of-sale terminal operator scans the bar code in Step 287 with the optical bar code scanner 286. The retail chain corporate LAN network 290 receives the information from the point-of-sale terminal
20 285 and is connected to the coupon service server 200 via the firewall 295, Internet 220, and firewall 210 as with Fig. 4. The remainder of the operation is identical to that of the arrangement of Fig. 4.

 Fig. 6 illustrates the flow of data from a wireless terminal to a point-of-sale terminal via an infrared link. The operation of the system of Fig. 6 is the same as that of Fig. 4 with

the exception that the wireless terminal 281 is connected to the point-of-sale terminal 285 via infrared transceivers 330 and 310 and infrared link 320.

Fig. 7 illustrates the flow of data from a wireless terminal to a point-of-sale terminal via GPRS (general packet radio service).

5 In this arrangement, the wireless terminal 281 transmits the coupon ID information to the point-of-sale terminal 285 via the BTS 271, GPRS or 3G network 260, SGSN 250, GPRS network operator 240, GGSN 230, Internet 230, firewall 295, and the retail chain corporate LAN network 290. The path between the wireless terminal 281 and the Internet 220 may be the same path used to receive the coupon ID information from the coupon
10 service server 200 as noted above with regard to Fig. 3.

The operation of the system illustrated in Fig. 7 is otherwise identical to that of Fig. 4 and accordingly, the details thereof have been omitted for the sake of brevity.

Fig. 8 illustrates the flow of data from one wireless terminal to another wireless terminal via GPRS.

15 As shown in Fig. 8, the wireless terminal 281 may transmit or forward coupon ID data contained therein to wireless terminal 280 via BTS 271, the GPRS or 3G network 260, and the BTS 270. Note that the wireless terminal 281 may have received the coupon ID data from the GPRS network operator 240 via the SGSN 250 and GPRS or 3G network 260 and BTS 271 as previously noted in the discussion of Fig. 3.

20 The coupons may be transmitted or forwarded to other terminals other than the wireless terminal 280 via the GPRS or 3G network 260.

Fig. 9 illustrates the flow of data from one wireless terminal to another wireless terminal via an infrared link.

25 In this arrangement, wireless terminal 281 is connected to wireless terminal 280 via infrared transceiver 330, infrared link 350 and infrared transceiver 340. The coupon ID and

information is transmitted from terminal to terminal via the infrared link 350. The visual/textual representation may be transmitted simultaneously between the wireless terminals via the infrared link or may be downloaded from the coupon service server 200 at a later time.

5 Fig. 10 illustrates the flow of data from one wireless terminal to another via Bluetooth. The connection between two or more wireless terminals such as 280 and 281 is established via the Bluetooth low-range radio link 400. The coupon ID/information is transmitted from terminal 281 to terminal 280 via the Bluetooth link 400 and the visual/textual representation may be transmitted simultaneously or may be downloaded from
10 the coupon service server 200 at a later time.

 Fig. 11 illustrates the flow of data from one wireless terminal to another wireless terminal utilizing optical bar code scanning. The coupon ID is displayed as a bar code on the screen of wireless terminal 280. An optical bar code scanner 420 imbedded in wireless terminal 281 is used to scan the bar code 288 which is displayed on the wireless terminal
15 screen 410 of wireless terminal 280. Thus, the coupon ID is copied by wireless terminal 281. A network connection via GPRS, for example, may be used to verify the coupon immediately or at a later time period.

 Fig. 12 illustrates optically scanning a coupon ID from a print media source using a wireless terminal. Namely, a coupon is printed in a magazine, newspaper, leaflet, etc., the
20 coupon including a coupon ID printed in a bar code format 288. The wireless terminal 281 performs the Step 420 of scanning the printed bar code having the coupon ID utilizing an optical bar code reader imbedded in the wireless terminal 281.

 Once the coupon ID has been scanned by the wireless terminal 281, it may be stored and/or a visual and textual representation may be downloaded from the coupon service server
25 200 via the GPRS-Internet connection 450. By this technique, the user of the wireless

terminal 281 may also take advantage of printed coupons without having to resort to the inefficient conventional steps used to redeem paper coupons.

Fig. 13 illustrates the transmission of an electronic coupon utilizing a Bluetooth transmitter.

5 As the user of the wireless terminal 281 comes in proximity to a physical point of interest where a Bluetooth transmitter used to transmit an electronic coupons resides, the Bluetooth transmitter transmits coupon IDs or coupon information to the wireless terminal 281. The Bluetooth transmitter 460 receives the coupon IDs or coupon information from the coupon service server 200 via the firewall 210 and Internet 220.

10 In the case of only coupon IDs being transmitted by the Bluetooth transmitter 460, the coupon visual and textual representation is retrieved by the wireless terminal 281 from the coupon service server 200 via the GPRS-Internet connection 450.

 The Bluetooth transmitter 460 can be placed in a retail store, shopping mall, or any location where there is a reasonably large volume of traffic flow, such as an airport or
15 subway station, thereby serving as an advertising medium in conjunction with some sort of visual display related to the electronically transmitted coupons.

 Fig. 14 illustrates the transmission of an electronic coupon to a wireless terminal via a GPRS network.

 The coupon ID and coupon information, and optionally the visual and textual
20 representation thereof, are delivered to the wireless terminal 281 via the GPRS or 3G network 260 which is connected to the coupon service server 200 via the firewall 210, Internet 220, GGSN 230, GPRS network operator 240, and SGSN 250. The coupon ID and the representation can either be transmitted simultaneously or maybe transmitted at separate times.

This concludes the description of the example embodiments. Although the present invention has been described with reference to a number of illustrative embodiments thereof, it should be understood that numerous other modifications and embodiments can be devised by those skilled in the art that will fall within the spirit and scope of the principles of this invention. More particularly, reasonable variations and modifications are possible in the component parts and/or arrangements of the subject combination arrangement within the scope of the foregoing disclosure, the drawings, and the appended claims without departing from the spirit of the invention. In addition to variations and modifications in the components and/or arrangements, alternative uses will also be apparent to those skilled in the art.

For example, while various electronic transmission elements and methods have been disclosed, the present invention should not be construed as being limited to those disclosed methods and equipment. Although the Internet has been discussed above as a communications path, it is to be understood that the present invention should in no way be construed as being limited thereto. For example, a wireless LAN (Local Area Network) path could also be used.

What is claimed is:

- 1 1. An electronic couponing method comprising the steps of:
2 transferring coupon information to a first portable terminal and storing same therein;
3 displaying a representation of the transferred coupon information on the first
4 portable terminal; and
5 transferring at least part of the stored coupon information from the first portable
6 terminal to another terminal for redemption.
- 7 2. An electronic couponing method comprising the steps of:
8 transferring coupon information to a first portable terminal and storing same therein;
9 displaying a representation of the transferred coupon information on the first
10 portable terminal; and
11 transferring at least part of the stored coupon information from the first portable
12 terminal to a second portable terminal.
- 13 3. An electronic couponing system comprising:
14 a first portable terminal having a memory;
15 a first transfer unit for transferring coupon information to said first portable terminal,
16 said first portable terminal storing same in said memory thereof;
17 a display disposed within said first portable terminal for displaying a representation
18 of said transferred coupon information from said first portable terminal; and
19 a second transfer unit for transferring at least part of said stored coupon information
20 to another terminal for redemption.
- 21 4. An electronic couponing system comprising:
22 a first portable terminal having a memory;

- 23 a first transfer unit for transferring coupon information to said portable terminal, said
24 portable terminal storing same in said memory thereof;
- 25 a display disposed within said first portable terminal for displaying a representation
26 of said transferred coupon information;
- 27 a second portable terminal; and
- 28 a second transfer unit for transferring at least part of said stored coupon information
29 from said first portable terminal to said second portable terminal .
- 30 5. The method of claim 1, wherein at least part of the coupon information is
31 transferred to the first portable terminal by optically scanning information with an optical
32 scanner.
- 33 6. The method of claim 1, wherein at least part of the coupon information is
34 transferred to the first portable terminal with a Bluetooth radio link.
- 35 7. The method of claim 1, wherein at least part of the coupon information is
36 transferred to the first portable terminal via the Internet.
- 37 8. The method of claim 7, wherein at least part of the coupon information is
38 transferred from the Internet to the first portable terminal via a wireless link.
- 39 9. The method of claim 1, wherein at least part of the stored coupon
40 information is transferred from the first portable terminal to another terminal via optically
41 scanning the displayed representation of the transferred coupon information on the portable
42 terminal.
- 43 10. The method of claim 1, wherein at least part of the stored coupon
44 information is transferred from the first portable terminal to another portable terminal via a
45 Bluetooth radio link.

- 1 11. The method of claim 1, wherein at least part of the stored coupon
2 information is transferred from the first portable terminal to another terminal via an infrared
3 link.
- 4 12. The method of claim 1, wherein at least part of the stored coupon
5 information is transferred from the first portable terminal to another terminal via the Internet.
- 6 13. The method of 7, wherein at least part of the stored coupon information is
7 transferred from the first portable to another terminal via the Internet via a wireless link.
- 8 14. The method of claim 2, wherein at least part of the coupon information is
9 transferred to the first portable terminal by optically scanning information with an optical
10 scanner.
- 11 15. The method of claim 2, wherein at least part of the coupon information is
12 transferred to the first portable terminal with a Bluetooth radio link.
- 13 16. The method of claim 2, wherein at least part of the coupon information is
14 transferred to the first portable terminal via the Internet.
- 15 17. The method of claim 2, wherein at least part of the coupon information is
16 transferred from the Internet to the first portable terminal via a wireless link.
- 17 18. The method of claim 2, wherein at least part of the stored coupon
18 information is transferred from the first portable terminal to a second portable terminal via
19 the Internet.
- 20 19. The method of claim 18, wherein at least part of the stored coupon
21 information is transferred from the first portable terminal to a second portable terminal via
22 the Internet via a wireless link.
- 23 20. The method of claim 2, wherein at least part of the stored coupon
24 information is transferred from the first portable terminal to a second portable terminal via an
25 infrared link.

1 21. The method of claim 2, wherein at least part of the stored coupon
2 information is transferred from the first portable terminal to a second portable terminal via a
3 Bluetooth radio link.

4 22. The method of claim 2, wherein at least part of the stored coupon
5 information is transferred from the first portable terminal to a second portable terminal via
6 optically scanning the displayed representation of the transferred coupon information on the
7 first portable terminal.

8 23. The system of claim 3, wherein said first transfer unit comprises an optical
9 scanner for optically scanning a representation of said coupon information.

10 24. The system of claim 3, wherein said first transfer unit comprises a Bluetooth
11 radio link.

12 25. The system of claim 3, wherein said first transfer unit comprises the Internet.

13 26. The system of claim 25, wherein said first transfer unit further comprises a
14 wireless link.

15 27. The system of claim 3, wherein said second transfer unit comprises an
16 optical scanner for scanning the representation of said transferred coupon information on
17 said display of said first portable terminal.

18 28. The system of claim 3, wherein said second transfer unit comprises a
19 Bluetooth radio link.

20 29. The system of claim 3, wherein said second transfer unit comprises an
21 infrared link.

22 30. The system of claim 3, wherein said second transfer unit comprises the
23 Internet.

- 1 31. The system of claim 30, wherein said second transfer unit further comprises
2 a wireless link.
- 3 32. The system of claim 4, wherein said first transfer unit comprises an optical
4 scanner for optically scanning a representation of said coupon information.
- 5 33. The system of claim 4, wherein said first transfer unit comprises a Bluetooth
6 radio link.
- 7 34. The system of claim 4, wherein said first transfer unit comprises the Internet.
- 8 35. The system of claim 33, wherein said first transfer unit further comprises a
9 wireless link.
- 10 36. The system of claim 4, wherein said second transfer unit comprises the
11 Internet.
- 12 37. The system of claim 36, wherein said second transfer unit further comprises
13 a wireless link.
- 14 38. The system of claim 4, wherein said second transfer unit comprises an
15 infrared link.
- 16 39. The system of claim 4, wherein said second transfer unit comprises a
17 Bluetooth radio link.
- 18 40. The system of claim 4, wherein said second transfer unit comprises an
19 optical scanner for scanning said representation of said transferred coupon information on
20 said display of said first portable terminal.
- 21 41. An electronic couponing method comprising the steps of:
22 transferring coupon information to a first portable terminal and storing same therein;
23 displaying a representation of the transferred coupon information on the first
24 portable terminal;

25 transferring at least part of the stored coupon information from the first portable
26 terminal to another terminal for redemption; and
27 transferring at least part of the stored coupon information from the first portable
28 terminal to a second portable terminal.

29 42. An electronic couponing system comprising:
30 a first portable terminal having a memory;
31 a first transfer unit for transferring coupon information to said first portable terminal,
32 said first portable terminal storing same in said memory thereof;
33 a display disposed within said first portable terminal for displaying a representation
34 of said transferred coupon information;
35 a second transfer unit for transferring at least part of said stored coupon information
36 from said first portable terminal to another terminal for redemption;
37 a second portable terminal; and
38 a third transfer unit for transferring at least part said stored coupon information from
39 said first portable terminal to said second portable terminal.

40 43. The method of claim 1, wherein said coupon information comprises a
41 coupon ID (identification).

42 44. The method of claim 2, wherein said coupon information comprises a
43 coupon ID (identification).

44 45. The method of claim 41, wherein said coupon information comprises a
45 coupon ID (identification).

46 46. The system of claim 3, wherein said coupon information comprises a coupon
47 ID (identification).

48 47. The system of claim 4, wherein said coupon information comprises a coupon
49 ID (identification).

- 50 48. The system of claim 42, wherein said coupon information comprises a
51 coupon ID (identification).
- 52 49. The method of claim 1, wherein at least part of the coupon information is
53 transferred to the first portable terminal via a wireless LAN (Local Area Network).
- 54 50. The method of claim 1, wherein at least part of the stored coupon
55 information is transferred from the first portable terminal to another terminal via a wireless
56 LAN (Local Area Network).
- 1 51. The method of claim 2, wherein at least part of the coupon information is
2 transferred to the first portable terminal via a wireless LAN (Local Area Network).
- 1 52. The method of claim 2, wherein at least part of the stored coupon
2 information is transferred from the first portable terminal to a second portable terminal via
3 a wireless LAN (Local Area Network).
- 1 53. The system of claim 3, wherein said first transfer unit comprises a wireless
2 LAN (Local Area Network).
- 1 54. The system of claim 3, wherein said second transfer unit comprises a
2 wireless LAN (Local Area Network).
- 1 55. The system of claim 4, wherein said first transfer unit comprises a wireless
2 LAN (Local Area Network).
- 1 56. The system of claim 4, wherein said second transfer unit comprises a
2 wireless LAN (Local Area Network).

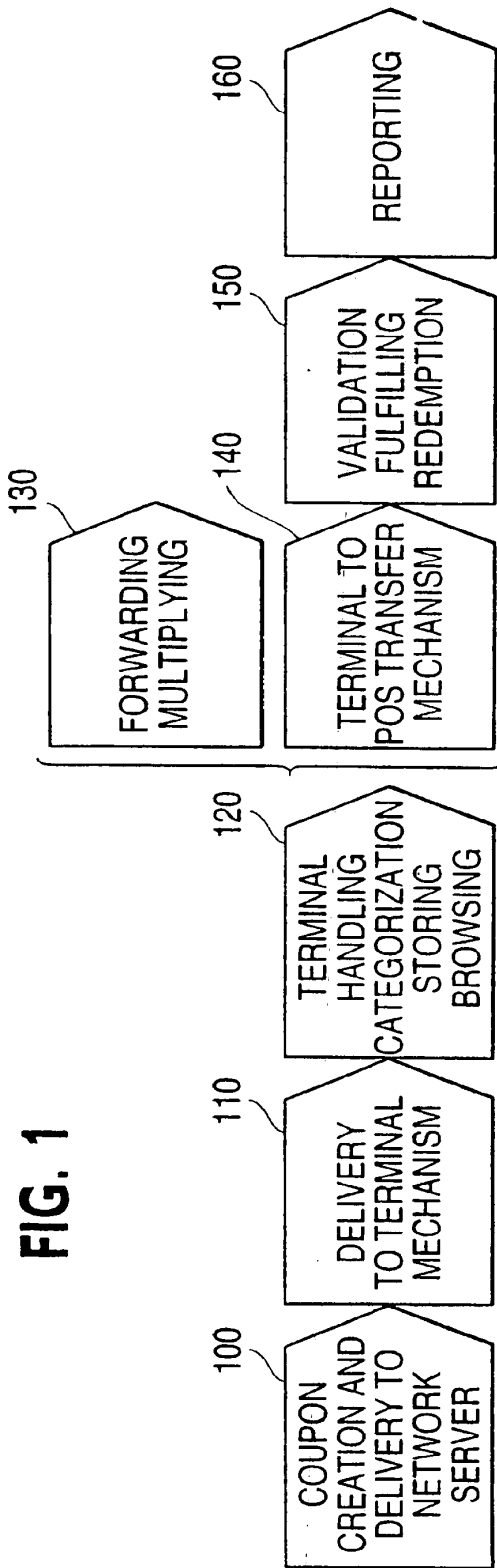

FIG. 1

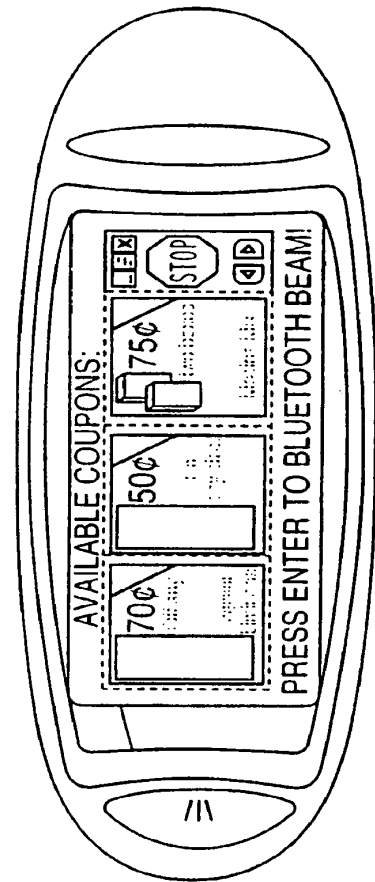

FIG. 2

FIG. 3

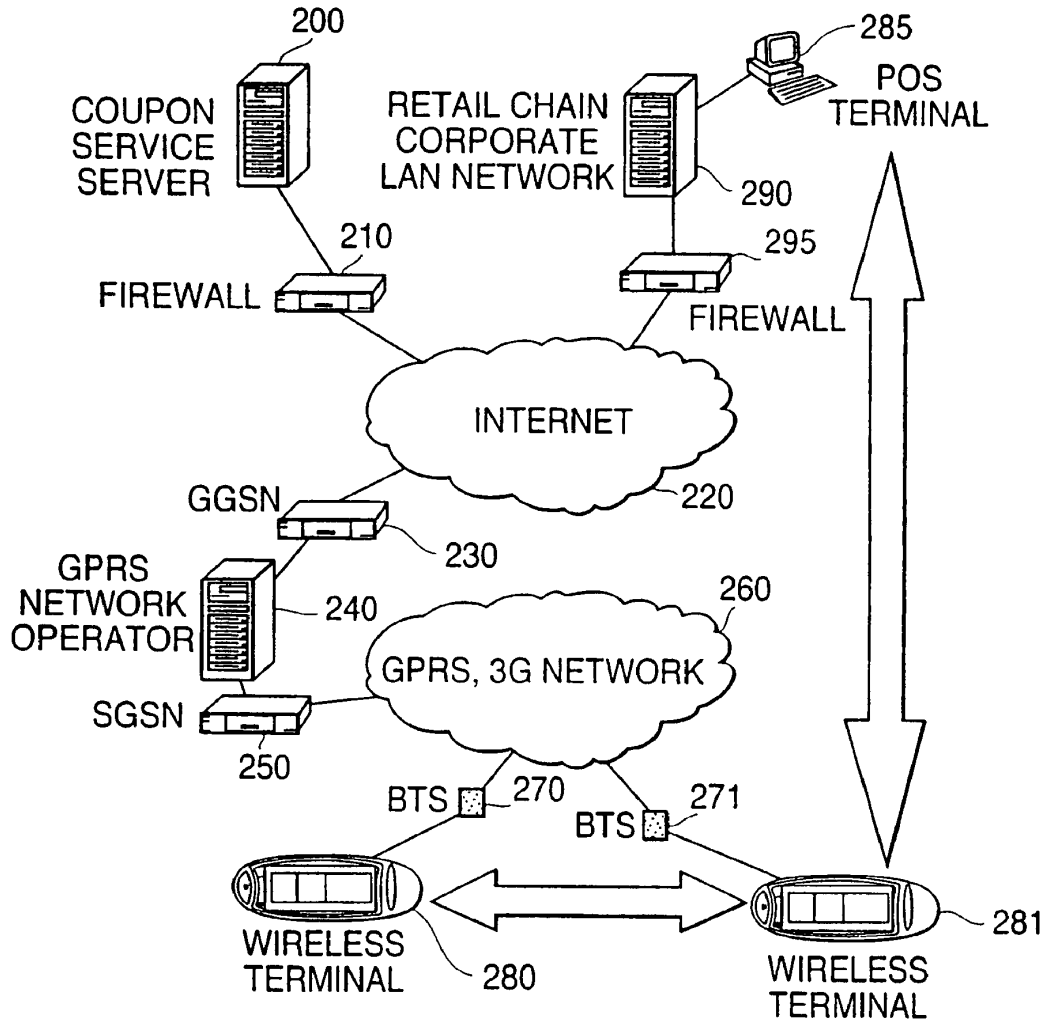

FIG. 4

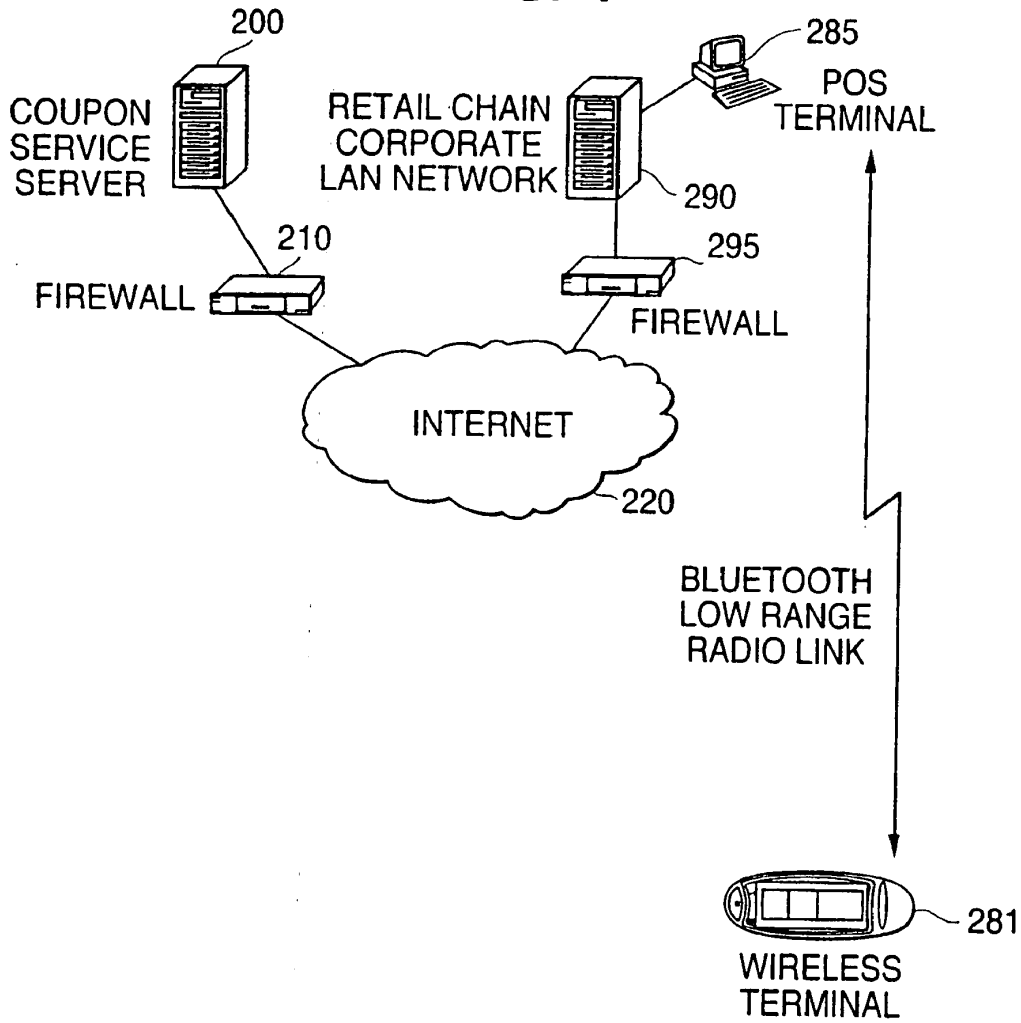

FIG. 5

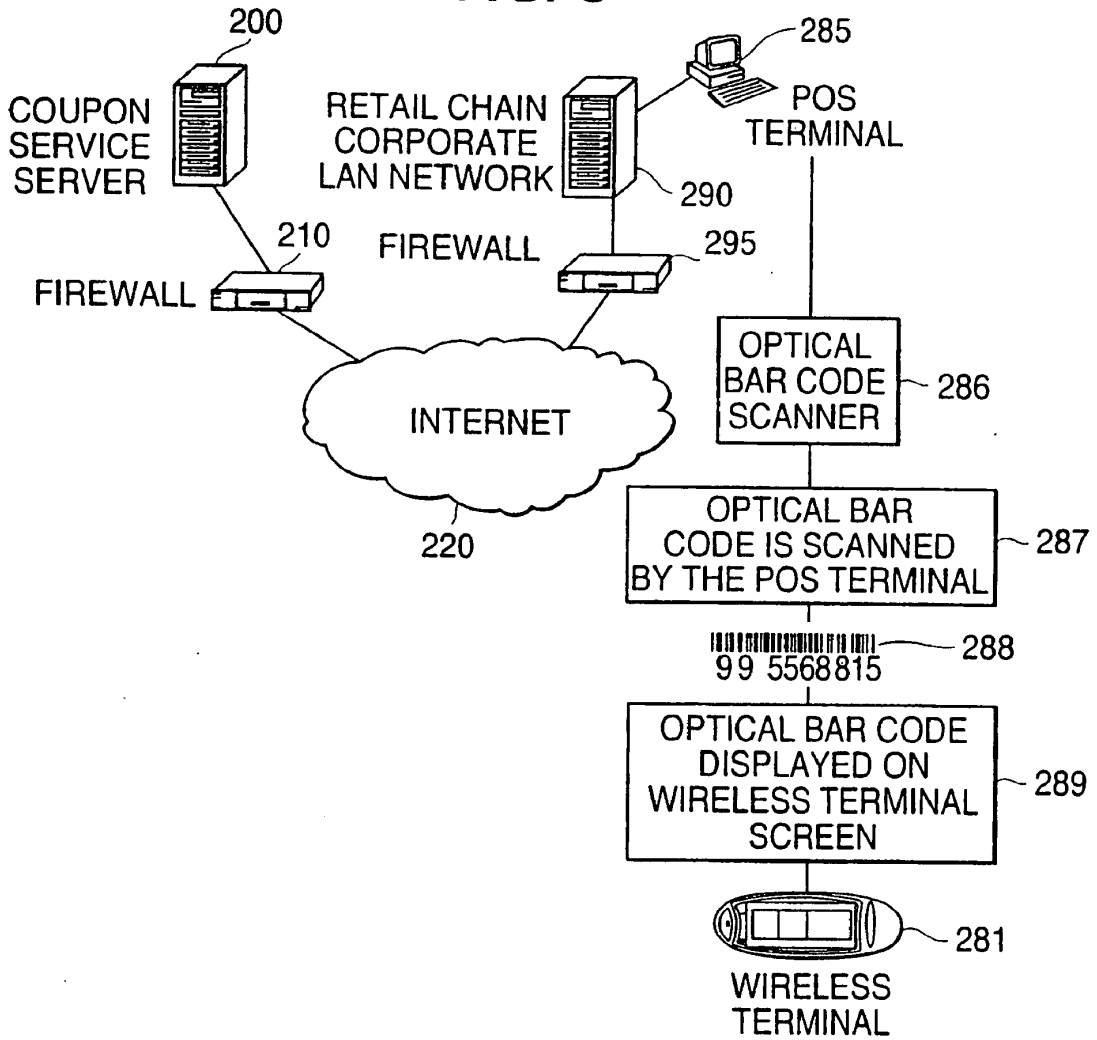

FIG. 6

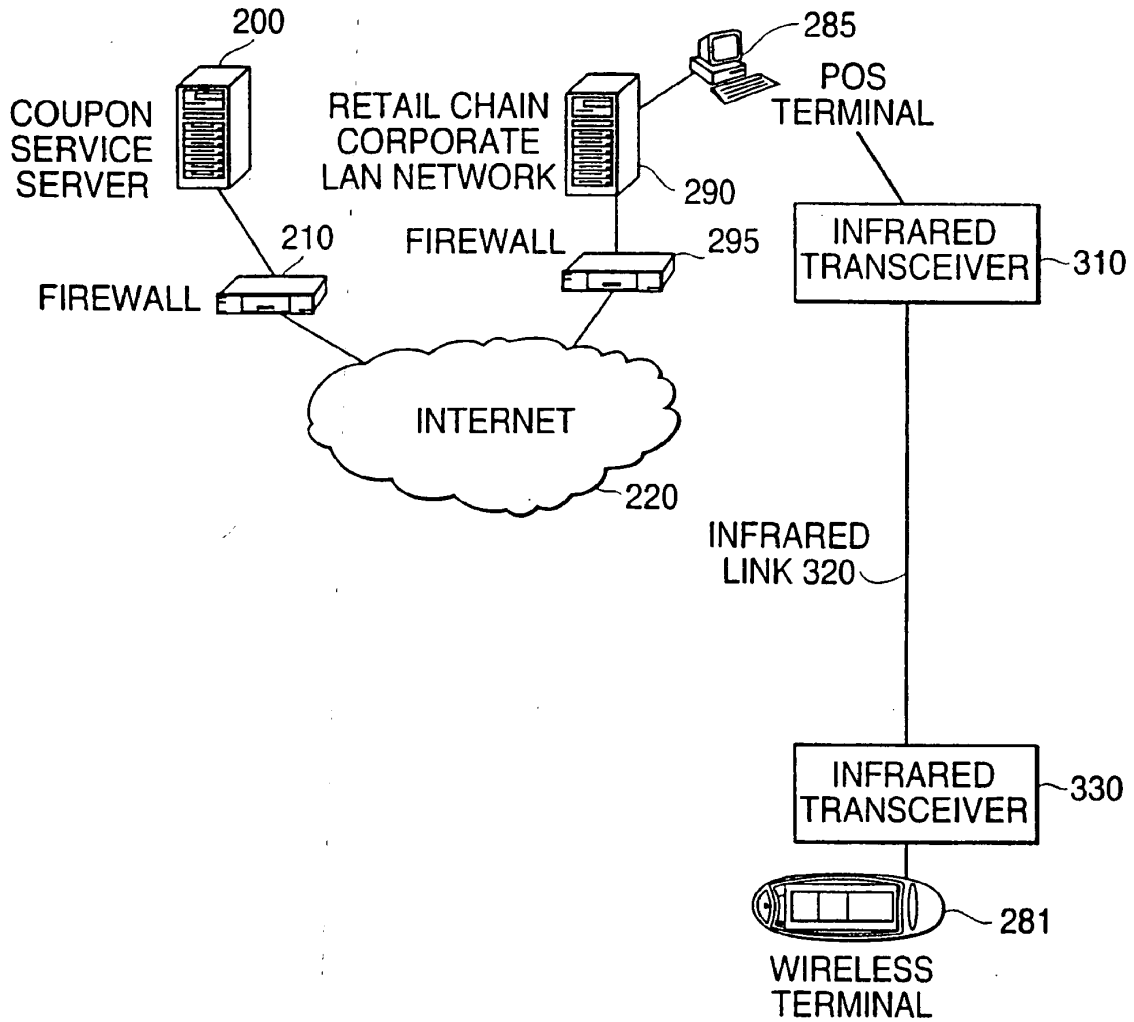

FIG. 7

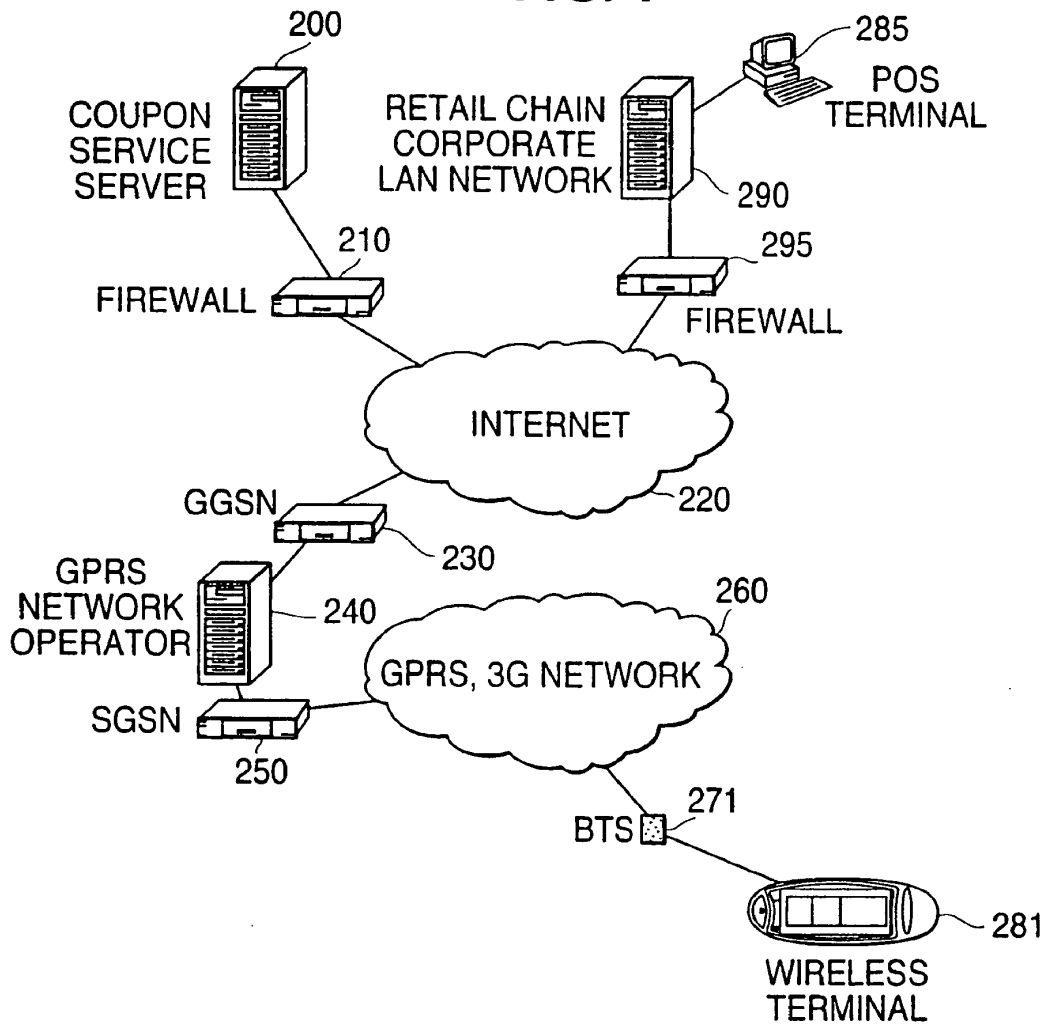

FIG. 8

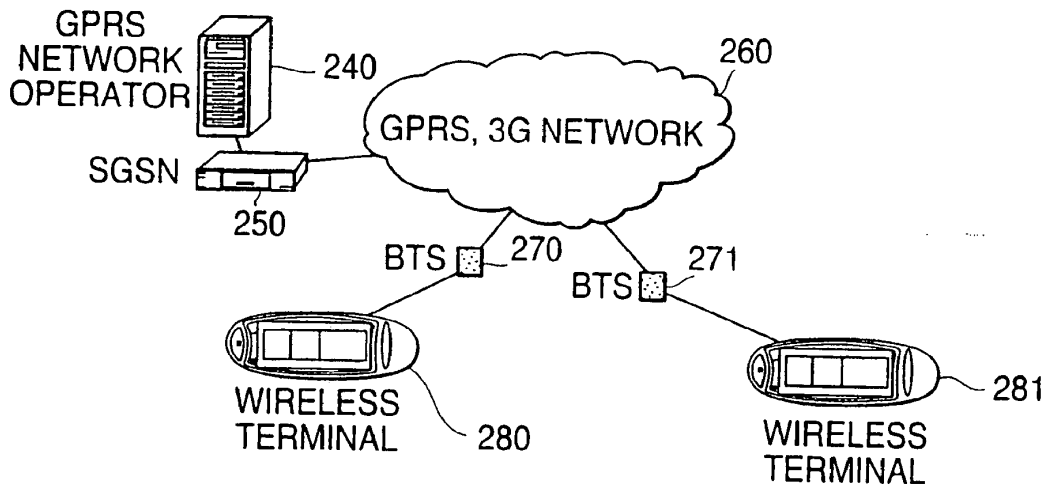

FIG. 9

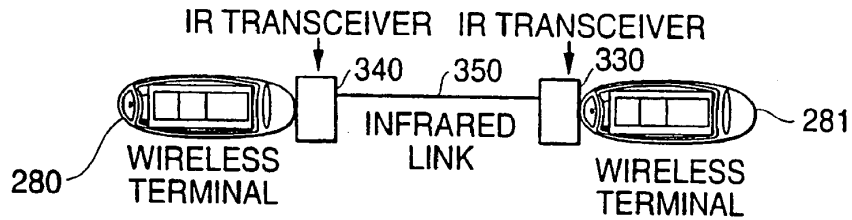

FIG. 10

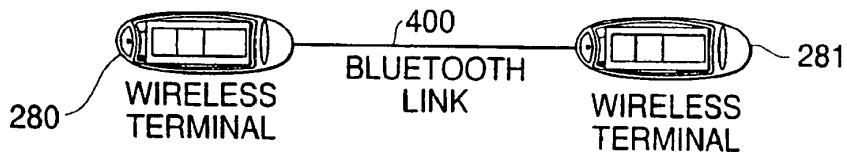

FIG. 11

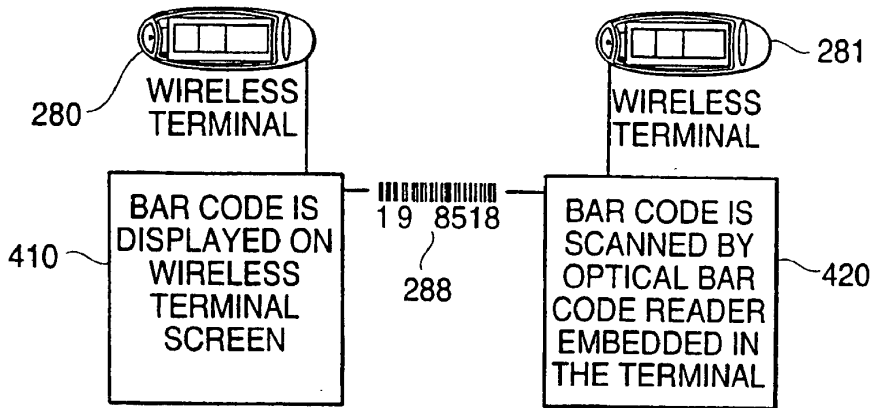

FIG. 12

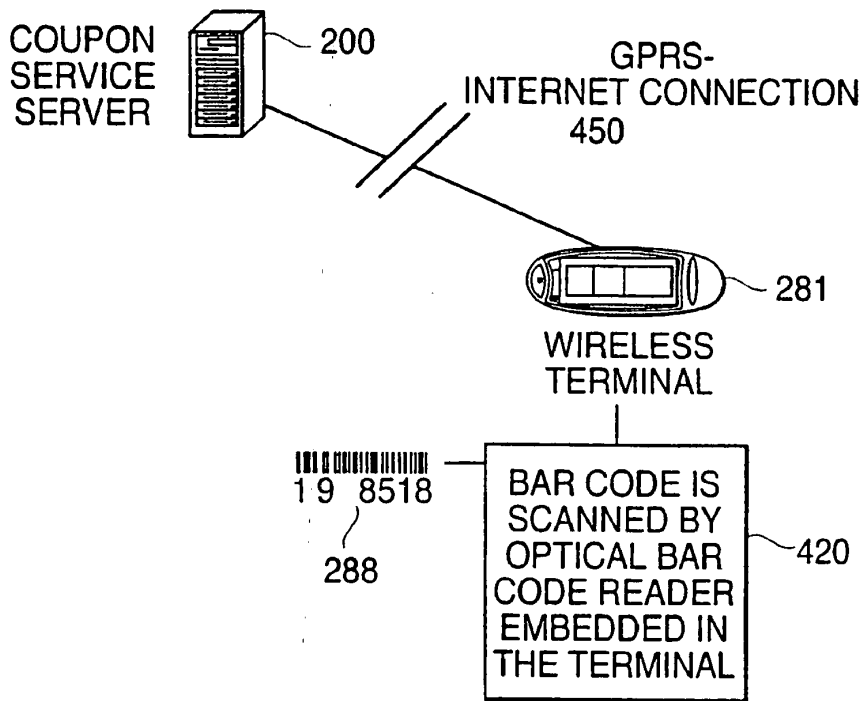
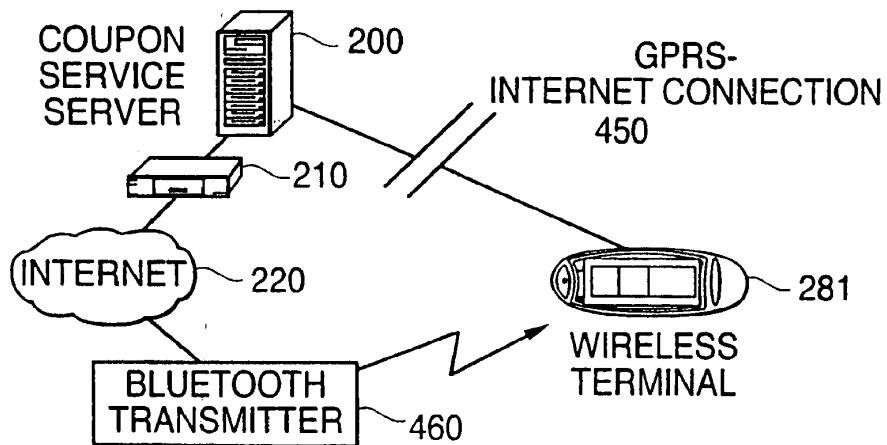
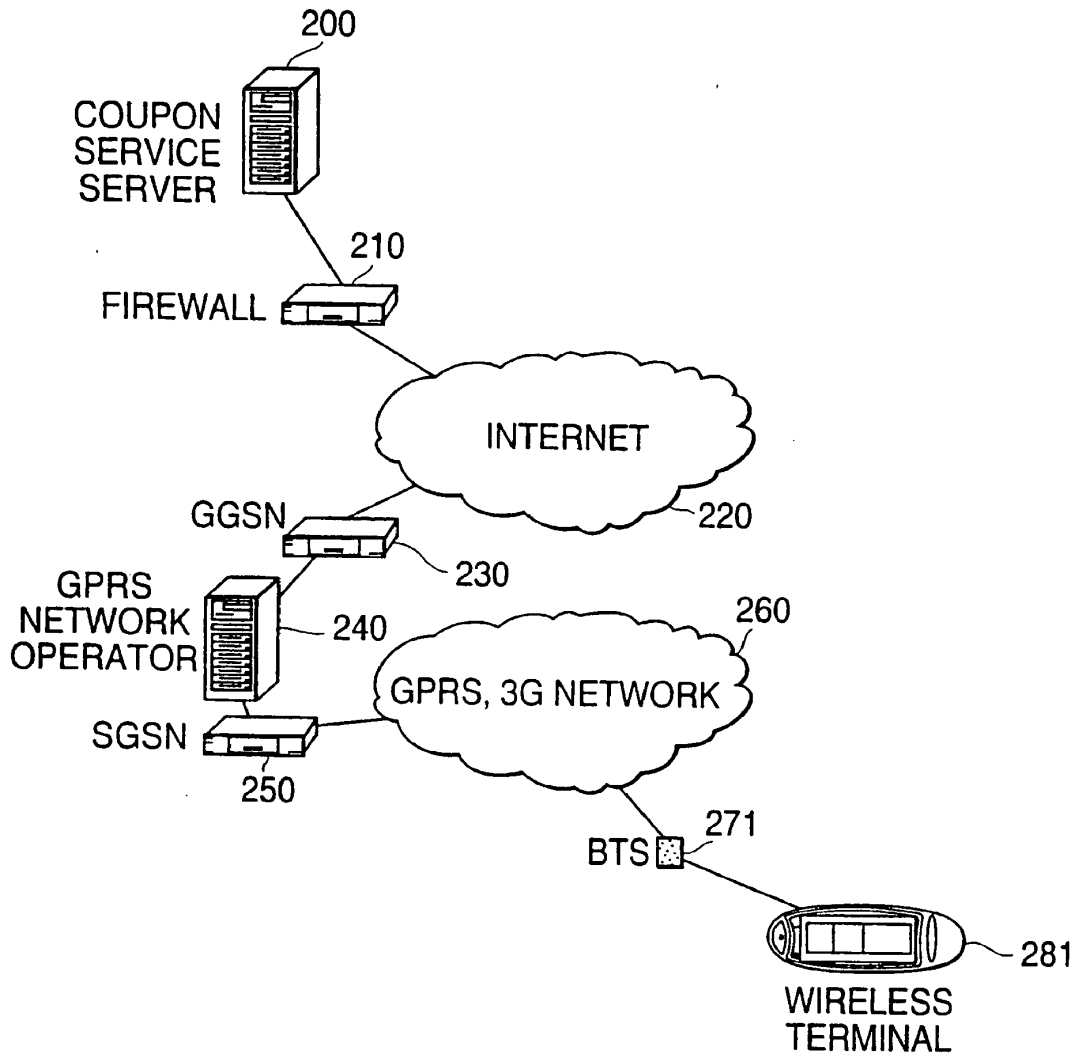

FIG. 13



SUBSTITUTE SHEET (RULE 26)

FIG. 14



(19) World Intellectual Property Organization
International Bureau



(43) International Publication Date
21 June 2001 (21.06.2001)

PCT

(10) International Publication Number
WO 01/45061 A3

- (51) International Patent Classification⁷: G07G 1/14
- (21) International Application Number: PCT/IB00/01872
- (22) International Filing Date: 14 December 2000 (14.12.2000)
- (25) Filing Language: English
- (26) Publication Language: English
- (30) Priority Data: 09/461,353 15 December 1999 (15.12.1999) US
- (71) Applicant: NOKIA CORPORATION [FI/FI]; Keilalahdentie 4, FIN-02150 Espoo (FI).
- (71) Applicant (for LC only): NOKIA INC. [US/US]; 6000 Connection Drive, Irving, TX 75039 (US).
- (72) Inventor: RISSANEN, Jussi; Pajalahdentie 6 A 18, FIN-00200 Helsinki (FI).
- (74) Agents: BRUNDIDGE, Carl, I. et al.; Antonelli, Terry, Stout & Kraus, LLP, Suite 1800, 1300 N. Seventeenth Street, Arlington, VA 22209 (US).
- (81) Designated States (national): AE, AG, AL, AM, AT, AU, AZ, BA, BB, BG, BR, BY, CA, CH, CN, CR, CU, CZ, DE, DK, DM, DZ, EE, ES, FI, GB, GD, GE, GH, GM, HR, HU, ID, IL, IN, IS, JP, KE, KG, KP, KR, KZ, LC, LK, LR, LS, LT, LU, LV, MA, MD, MG, MK, MN, MW, MX, NO, NZ, PL, PT, RO, RU, SD, SE, SG, SI, SK, SL, TJ, TM, TR, TT, TZ, UA, UG, UZ, VN, YU, ZA, ZW.
- (84) Designated States (regional): ARIPO patent (GH, GM, KE, LS, MW, MZ, SD, SL, SZ, TZ, UG, ZW), Eurasian patent (AM, AZ, BY, KG, KZ, MD, RU, TJ, TM), European patent (AT, BE, CH, CY, DE, DK, ES, FI, FR, GB, GR, IE,

[Continued on next page]

(54) Title: WIRELESS ELECTRONIC COUPONING TECHNIQUE

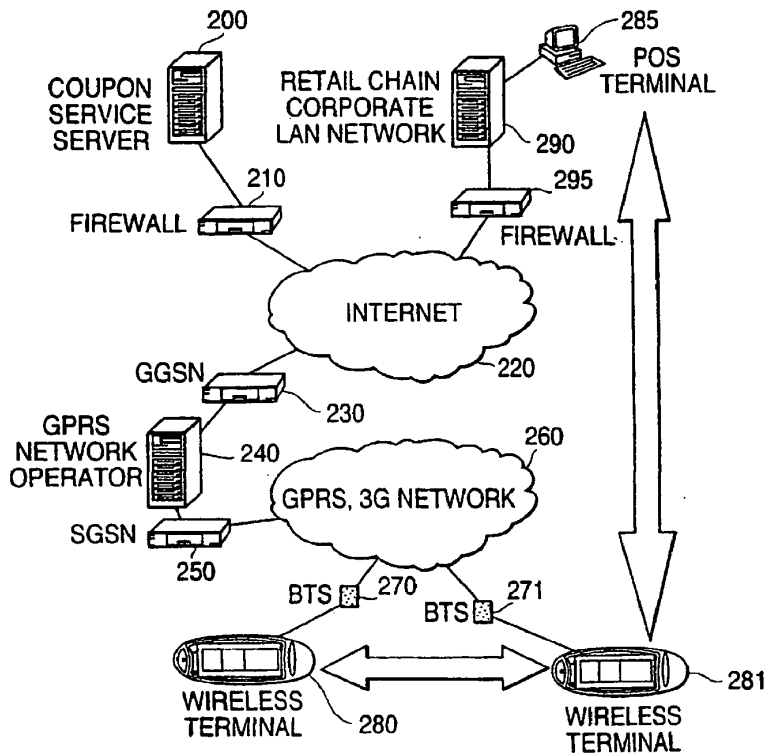

(57) Abstract: An electronic couponing technique includes transferring coupon information, which may include a coupon ID (identification) to a first portable terminal and storing same therein. The portable terminal displays a representation of the transferred coupon information on a display thereof. The stored coupon information may be transferred from the portable terminal to another terminal for redemption. The stored coupon information may also be transferred from the portable terminal to another portable terminal. Various schemes may be used to transfer the coupon information including a Bluetooth low-range radio link or an optical bar code scanner scanning an optical bar code or an infrared link or a wireless link from the portable terminal. The Internet or wireless LAN (Local Area Network) may also be used in transferring the coupon information to and from the various terminals.

WO 01/45061 A3



IT, LU, MC, NL, PT, SE, TR), OAPI patent (BF, BJ, CF, CG, CI, CM, GA, GN, GW, ML, MR, NE, SN, TD, TG).

(88) Date of publication of the international search report:
18 April 2002

Published:

- with international search report
- before the expiration of the time limit for amending the claims and to be republished in the event of receipt of amendments

For two-letter codes and other abbreviations, refer to the "Guidance Notes on Codes and Abbreviations" appearing at the beginning of each regular issue of the PCT Gazette.

INTERNATIONAL SEARCH REPORT

International Application No
PCT/IB 00/01872

A. CLASSIFICATION OF SUBJECT MATTER
IPC 7 G07G1/14

According to International Patent Classification (IPC) or to both national classification and IPC

B. FIELDS SEARCHED

Minimum documentation searched (classification system followed by classification symbols)
IPC 7 G07G G06F G07F

Documentation searched other than minimum documentation to the extent that such documents are included in the fields searched

Electronic data base consulted during the international search (name of data base and, where practical, search terms used)

EPO-Internal, WPI Data

C. DOCUMENTS CONSIDERED TO BE RELEVANT

Category *	Citation of document, with indication, where appropriate, of the relevant passages	Relevant to claim No.
X	WO 97 21200 A (LEE CHONG U ;MOALLEMI KAMRAN (US); WARREN ROBERT L (US); SOLONATE) 12 June 1997 (1997-06-12)	1,3,5,7, 25,30, 34,36, 43,46
Y	page 2, line 15 -page 4, line 14; figure 1	2,4,6,8, 10-21, 23,24, 26-29, 31-33, 35, 37-39, 41,42, 44,45, 47-56
	page 4, line 10-12 page 6, line 9-14 ----- -/--	

Further documents are listed in the continuation of box C.

Patent family members are listed in annex.

* Special categories of cited documents :

- *A* document defining the general state of the art which is not considered to be of particular relevance
- *E* earlier document but published on or after the international filing date
- *L* document which may throw doubts on priority claim(s) or which is cited to establish the publication date of another citation or other special reason (as specified)
- *O* document referring to an oral disclosure, use, exhibition or other means
- *P* document published prior to the international filing date but later than the priority date claimed

- *T* later document published after the international filing date or priority date and not in conflict with the application but cited to understand the principle or theory underlying the invention
- *X* document of particular relevance; the claimed invention cannot be considered novel or cannot be considered to involve an inventive step when the document is taken alone
- *Y* document of particular relevance; the claimed invention cannot be considered to involve an inventive step when the document is combined with one or more other such documents, such combination being obvious to a person skilled in the art.
- *&* document member of the same patent family

Date of the actual completion of the international search

1 February 2002

Date of mailing of the international search report

19/02/2002

Name and mailing address of the ISA

European Patent Office, P.B. 5818 Patentlaan 2
NL - 2280 HV Rijswijk
Tel. (+31-70) 340-2040, Tx. 31 651 epo nl,
Fax: (+31-70) 340-3016

Authorized officer

Laub, C

INTERNATIONAL SEARCH REPORT

International Application No
PCT/IB 00/01872

C.(Continuation) DOCUMENTS CONSIDERED TO BE RELEVANT		
Category *	Citation of document, with indication, where appropriate, of the relevant passages	Relevant to claim No.
Y	US 5 420 606 A (GEIGER MARK A ET AL) 30 May 1995 (1995-05-30)	11,29
A	column 4, line 60-67; claim 9; figure 1	1,5,20, 38
Y	US 5 979 757 A (MURRAH JUDITH ET AL) 9 November 1999 (1999-11-09)	6,8,12, 13,19, 23,26,27
A	column 1, line 30-40; figure 3 column 2, line 12-15	5,15,17, 18,21, 31,32, 35,37
Y	EP 0 950 968 A (MATSUSHITA ELECTRIC IND CO LTD) 20 October 1999 (1999-10-20)	2,4, 14-18, 20,21, 31-33, 35, 37-39, 41,42, 44,45, 47,48, 51,52, 55,56
Y	figure 2A	
Y	US 5 657 317 A (BUNTE ALAN G ET AL) 12 August 1997 (1997-08-12)	10,24, 28,33, 39,49, 50,53,54
A	abstract; claim 6; figure 1B	17,39, 51,52,56

5

Form PCT/ISA/210 (continuation of second sheet) (July 1992)

INTERNATIONAL SEARCH REPORT

Information on patent family members

International Application No

PCT/IB 00/01872

Patent document cited in search report		Publication date	Patent family member(s)	Publication date
WO 9721200	A	12-06-1997	AU 1279897 A	27-06-1997
			EP 0871944 A2	21-10-1998
			WO 9721200 A2	12-06-1997
US 5420606	A	30-05-1995	CA 2117716 A1	21-03-1995
			DE 4433569 A1	23-03-1995
			GB 2282253 A , B	29-03-1995
			HK 1000329 A1	27-02-1998
			JP 2712139 B2	10-02-1998
			JP 7182564 A	21-07-1995
US 5979757	A	09-11-1999	US 5825002 A	20-10-1998
			US 6199753 B1	13-03-2001
			US 6330244 B1	11-12-2001
			US 5979753 A	09-11-1999
			US 6084528 A	04-07-2000
EP 0950968	A	20-10-1999	AU 8648498 A	08-03-1999
			EP 0950968 A1	20-10-1999
			CN 1246941 T	08-03-2000
			WO 9909502 A1	25-02-1999
US 5657317	A	12-08-1997	US 5555276 A	10-09-1996
			US 5602854 A	11-02-1997
			US 5365546 A	15-11-1994
			US 5052020 A	24-09-1991
			AU 700800 B2	14-01-1999
			AU 3145895 A	22-02-1996
			AU 715628 B2	03-02-2000
			AU 9815198 A	04-03-1999
			CA 2195661 A1	08-02-1996
			EP 0784893 A1	23-07-1997
			WO 9603823 A1	08-02-1996
			US 5790536 A	04-08-1998
			US 5726984 A	10-03-1998
			US 5949776 A	07-09-1999
			AU 6987694 A	12-12-1994
			CA 2184811 A1	08-09-1995
			WO 9427382 A1	24-11-1994
			WO 9524074 A1	08-09-1995
			US 5912926 A	15-06-1999
			US 5696903 A	09-12-1997
			CA 2162722 A1	24-11-1994
			AU 696841 B2	17-09-1998
			AU 5986994 A	19-07-1994
			CA 2152598 A1	07-07-1994
			EP 0681762 A1	15-11-1995
			WO 9415413 A1	07-07-1994
			US 5673031 A	30-09-1997
			US 5708680 A	13-01-1998
			US 5844893 A	01-12-1998
US 5940771 A	17-08-1999			
CA 2074169 A1	19-07-1991			
EP 0511295 A1	04-11-1992			
US 5331136 A	19-07-1994			
WO 9111065 A1	25-07-1991			
US 5680633 A	21-10-1997			
US 5567925 A	22-10-1996			

Form PCT/ISA/210 (patent family annex) (July 1992)

INTERNATIONAL SEARCH REPORT

Information on patent family members

International Application No
PCT/IB 00/01872

Patent document cited in search report	Publication date	Patent family member(s)	Publication date
US 5657317	A	US 5679943 A	21-10-1997
		US 5949056 A	07-09-1999
		US 5218187 A	08-06-1993
		US 5313053 A	17-05-1994

Form PCT/ISA/210 (patent family annex) (July, 1992)

(19) World Intellectual Property Organization
International Bureau



(43) International Publication Date
9 August 2001 (09.08.2001)

(10) International Publication Number
WO 01/57724 A1

PCT

(51) International Patent Classification⁷: G06F 17/30, 13/00

(21) International Application Number: PCT/AU01/00132

(22) International Filing Date: 1 February 2001 (01.02.2001)

(25) Filing Language: English

(26) Publication Language: English

(30) Priority Data:
PQ 9706 1 February 2000 (01.02.2000) AU

(71) Applicant (for all designated States except US):
NEXTGEN PTY LTD [AU/AU]; 9129 Waruda Street,
Kirribilli, NSW 2061 (AU).

(72) Inventor; and

(75) Inventor/Applicant (for US only): SCHULZ, Paul
[AU/AU]; 9/29 Waruda Street, Kirribilli, NSW 2061 (AU).

(74) Agent: GRIFFITH HACK; G.P.O. Box 4164, Sydney,
NSW 2001 (AU).

(81) Designated States (national): AE, AG, AL, AM, AT, AU, AZ, BA, BB, BG, BR, BY, BZ, CA, CH, CN, CR, CU, CZ, DE, DK, DM, DZ, EE, ES, FI, GB, GD, GE, GH, GM, HR, HU, ID, IL, IN, IS, JP, KE, KG, KP, KR, KZ, LC, LK, LR, LS, LT, LU, LV, MA, MD, MG, MK, MN, MW, MX, MZ, NO, NZ, PL, PT, RO, RU, SD, SE, SG, SI, SK, SL, TJ, TM, TR, TT, TZ, UA, UG, US, UZ, VN, YU, ZA, ZW.

(84) Designated States (regional): ARIPO patent (GH, GM, KE, LS, MW, MZ, SD, SL, SZ, TZ, UG, ZW), Eurasian patent (AM, AZ, BY, KG, KZ, MD, RU, TJ, TM), European patent (AT, BE, CH, CY, DE, DK, ES, FI, FR, GB, GR, IE, IT, LU, MC, NL, PT, SE, TR), OAPI patent (BF, BJ, CF, CG, CI, CM, GA, GN, GW, ML, MR, NE, SN, TD, TG).

Published:

— with international search report

For two-letter codes and other abbreviations, refer to the "Guidance Notes on Codes and Abbreviations" appearing at the beginning of each regular issue of the PCT Gazette.

(54) Title: INTERACTIVE AGENT FOR MOBILE DEVICE

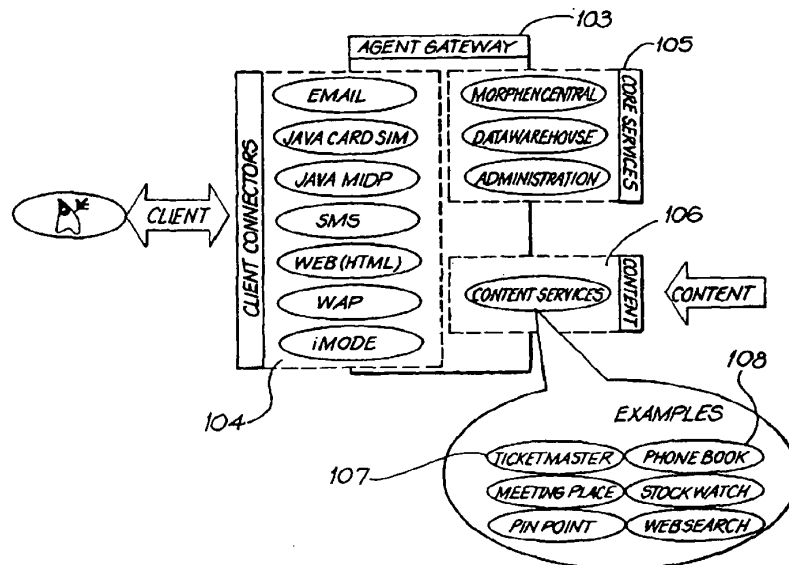

(57) Abstract: A system for providing an intelligent agent which is arranged to carry out tasks in response to instructions from a user, the tasks being actioned in a network environment, the system comprising agent interface means arranged to provide an agent interface at a user terminal for interaction with a user, and agent implementation means for implementing tasks instructed to the agent interface by the user, the user terminal typically comprising a mobile communications device utilising a mobile communications network for communications.



WO 01/57724 A1

INTERACTIVE AGENT FOR MOBILE DEVICEField of Invention

The present invention relates to a system for
5 providing an intelligent agent in a network environment,
and, particularly, but not exclusively, to a system for
providing an intelligent agent for use with mobile
communications devices.

10 Background of Invention

Mobile communications networks are well known. They
include cellular telephone networks, satellite based
networks, etc. Communication is most usually voice to
voice although message services, such as SMS are becoming
15 more prevalent with mobile telephones. In addition,
computing devices capable of utilising mobile telephone
networks for communications are available. These include,
in particular, "small computing devices", including laptop
computers, palm-top type computers. Mobile telephones
20 also fall within the definition of small computing device.
These types of small computing devices may use the mobile
communications networks to interface with other types of
networks, such as the Internet to eg. download
information. Communication networks which enable
25 different types of devices (not necessarily compatible
devices) to communicate with each other are also known,
utilising such technologies as BLUETOOTH™.

Communications via mobile networks require direct
"on-line" operation by a user. That is, for voice to
30 voice communications a user must dial a number (or hit an
auto-dial button) and then converse with the called party
in real time. Message services in mobile network, such as
SMS also require operation of an interface to enter a

- 2 -

message and respond to a message. Similarly, accessing other networks such as the Internet requires the user to operate an interface in real time to access the required Website and download the required information.

5 Intelligent agents, which do not require real-time user operation to carry out tasks instructed by a user, are known but are primitive. These include "Webbots" and "Crawlers" which can locate information on the Internet in accordance with instructions provided by a user. They are
10 not known for use with small computing devices communicating via mobile communications networks, such as mobile telephones.

Summary of Invention.

15 From a first aspect, the present invention provides a system for providing an intelligent agent which is arranged to carry out tasks in response to instructions from a user, the tasks being actioned in a network environment, the system comprising agent interface means
20 arranged to provide an agent interface at a user terminal for interaction with the user, and agent implementation means for implementing tasks instructed to the agent interface by the user.

An "intelligent agent" in its broadest sense, as
25 intended in the present specification, is a separate entity (software or hardware or a combination of software and hardware) which is able to operate to carry out instructions of a user or operator. An intelligent agent does not require real-time control by a user in order to
30 carry out a task that has been instructed.

The network environment may be any network environment. Preferably, the network environment is a public access network such as a mobile communications

Substitute Sheet
(Rule 26) RO/AU

- 3 -

network. The mobile communications network may interface with other networks such as the Internet and the intelligent agent can preferably access any interfaced networks to carry out tasks utilising those networks.

5 The user terminal is preferably a small computing device, and is preferably a palm-top computing device or mobile telephone type device. The user terminal is preferably a mobile device, such as palm-top computer having mobile communications facility, or a mobile
10 telephone.

The agent implementation means can preferably enable tasks to be carried out by the intelligent agent such as taking part in competitions. A mobile telephone user having access to an intelligent agent, therefore, could
15 enter and take part in a competition implemented by the system, such as a quiz. In return for success in the competition, the mobile user may win prizes. Such a use of the intelligent agent has the commercial effect of promoting network usage and therefore increasing revenue
20 to the mobile network owner.

The intelligent agent is preferably able to carry out tasks other than taking part in competitions. Other tasks include obtaining information requested by the user (for example by "trawling" the Internet for the information);
25 ordering tickets to entertainment venues (for example, ordering theatre tickets) - this particularly illustrates the advantages of using an intelligent agent in accordance with the present invention. Much time can be spent by a user on a telephone ordering tickets for entertainment
30 venues. With the present invention, the intelligent agent does all the "work" in ordering the tickets without any intervention required by the user apart from the original instructions (and perhaps confirmation of an order once

Substitute Sheet
(Rule 26) RO/AU

- 4 -

the intelligent agent has placed it); electronic commerce transactions on behalf of the user (this could include purchasing goods on behalf of user from, for example, Internet sites).

5 Preferably, the intelligent agent becomes associated with a particular user. In other words, the intelligent agent becomes "personalised". It acts as the users "helper" and stays with the user for a long period of time. The idea of an intelligent agent which is
10 associated with a particular user and in a sense "belongs" to the user is a novel one.

Preferably, the user terminal is a personal device which belongs to the user only. This is usually the case with palm-top type computers and certainly the case with
15 mobile telephones. Such a personal device usually incorporates facilities to ensure security. Preferably, security means are provided on the user terminal preventing unauthorised persons from accessing the intelligent agent. The agent therefore becomes a
20 "trusted" agent, personal to the user ("a personal trusted agent"). In mobile telephones, for example, a key set (eg. RSA) and a digital certificate (eg. X509) may exist on the mobile to allow it to act as a secure device and perform secure transactions. The intelligent agent may
25 utilise this key set and be verified via the use of a digital signature.

Preferably, therefore, the intelligent agent is securely associated with a particular user, preventing other persons from using the intelligent agent associated
30 with the user, or impersonating the intelligent agent.

The system of the present invention also preferably comprises attribute implementation means, arranged to

Substitute Sheet
(Rule 26) RO/AU

- 5 -

implement the provision of attributes to the intelligent agent.

The attributes are preferably arranged to determine the functionality of the intelligent agent in carrying out
5 tasks. For example, one attribute may determine how "good" an intelligent agent is at competitions, and could be termed "IQ". If a particular intelligent agent has a high IQ it may have a particular facility for competitions or particular types of competitions. The intelligent
10 agent may have other types of attributes which determine its functionality in different ways.

Preferably, the attribute implementation means is arranged to affect changes in the attributes of the intelligent agent in accordance with predetermined
15 criteria.

The predetermined criteria may include operation of the intelligent agent in carrying out tasks, preferably historical operation. For example, if an intelligent agent has entered a number of competitions and has done
20 well in them, this may automatically (implemented by the attribute implementation means) lead to an increase in the IQ of the agent. Another option is that a user may purchase new attributes (such as the facility, for eg. to obtain theatre tickets) from the system.

Preferably, the intelligent agent is arranged to "learn" as it is carrying out tasks for the user, the intelligent agent will pick up information while it is carrying out these tasks which can assist it in future tasks. In particular, the intelligent agent can acquire
30 more knowledge about the user as it performs tasks.

Preferably, the system provides a plurality of intelligent agents for use by a plurality of associated users. The users are preferably identified to the system.

Substitute Sheet
(Rule 26) RO/AU

- 6 -

This need not be by actual name, but could be by an identity number, for example.

Preferably, the system also includes an agent interaction means which is arranged to enable interaction
5 between intelligent agents. For example, a user's intelligent agent may carry a message for delivery to other user's intelligent agents.

Preferably, where the system also includes an attribute implementation means for providing attributes to
10 the intelligent agent, interaction between intelligent agents may depend on the respective attributes of the intelligent agents. For example, "compatible" intelligent agents may interact whereas "non-compatible" intelligent agents will not interact. Compatibility can be determined
15 by attributes both learned (as discussed above) or provided by a user, such as "appearance", "personality", "nationality" etc. These attributes may reflect attributes of the user (or may not) as may be determined by the user.

20 Compatibility between intelligent agents may eventually lead to the users communicating with each other, eg. by exchanging mobile telephone numbers. An advantage of this method of communication is that in the initial stages of intelligent agent interaction it is not
25 necessary to divulge any personal details of the user, such as telephone number. Interaction can proceed to a level where the users decide they actually want to talk to each other before the exchange of telephone numbers is required.

30 The system preferably further includes user "mood" determination means which is arranged to determine the mood of the user and affect the operation of the intelligent agent accordingly. Mood can be determined in

Substitute Sheet
(Rule 26) RO/AU

- 7 -

relation to any aspect of the user's behaviour. For example, if the user is busy, they may not wish to be "bothered" by interaction with the intelligent agent and the intelligent agent's behaviour will be adjusted accordingly. The assessment of whether or not the user is busy could be determined monitoring a number of factors including actual information input by the user to the user terminal, use of the user terminal (if use is frequent, it is likely that the user is busy). Also, if the user has been put into "silent" mode it is likely that the user is busy.

The system preferably further includes push content provision means for providing push content to the user terminal in association with the operation of the intelligent agent. It is therefore possible for third party originating information to be provided to the user via the intelligent agent, which can include advertising, for example. Revenue can thus be earned from the system and it may not even be necessary to charge the user for the intelligent agent, which makes the system very attractive to a user. Further, push content can be "targeted" taking account of the attributes of the particular intelligent agent (particularly where these may reflect the personality of the user) and operation of the intelligent agent (eg. monitoring the type of tasks that the user puts the intelligent agent to). Advertising information therefore becomes less intrusive, as it is targeted towards the particular user ie. the user actually wishes to receive this type of advertising information. The user may indicate what type of information he wants to receive by input to the user terminal.

Preferably, the system further includes means arranged to determine the location of a user terminal

Substitute Sheet
(Rule 26) RO/AU

- 8 -

associated with an intelligent agent. Where the user terminals are mobile terminals, such as mobile telephones, this system can preferably locate the mobile telephone physically. The agent implementation means is preferably
5 arranged to affect operation of the intelligent agent in accordance with the physical location of the user terminal. It may detect, for example, that the location of the intelligent agent is proximate a particular retail location, enabling push content to be broadcast to the
10 user terminal via the intelligent agent, relevant to the particular retail location.

The agent interface is preferably arranged to represent the intelligent agent at the user terminal as a characterisation, eg. as a type of "creature", having
15 attributes as discussed above. The "creature" essentially "lives" on the user terminal and carries out tasks for the user. Over time it becomes the user's "friend". This type of personalised intelligent agent is particularly novel. In particular, with the security means discussed
20 above, the user can completely trust the intelligent agent (as other parties are prevented from fraudulently using or impersonating the intelligent agent). The intelligent agent becomes the user's "trusted intelligent agent".

The user terminal may be arranged to interface with a
25 number of networks. For example, one interface may be with a mobile communications network via a mobile communications network operator. The agent implementation means may at least in part be provided by the network operator or a system connected to or associated with the
30 network operator. A first network interface means is provided at the mobile user terminal to interface with the mobile network (e.g. a wireless transceiver for transmission/reception with mobile network base stations).

Substitute Sheet
(Rule 26) RO/AU

- 9 -

Preferably, the user terminal may in addition be provided with further network interface means, for interfacing with further networks. For example, a transceiver may be provided for interfacing with a micro-network in, for example, a retail store or restaurant. The agent may, therefore, obtain information via the micro-network and carry out a task by the micro-network e.g. with a BLUETOOTH™ server in a restaurant or retail store.

Preferably, the system is also arranged to provide transient agents which include a transient agent interface means arranged to provide a transient agent interface at a user terminal and transient agent implementation means for implementing transient agent tasks. A transient agent may be broadcast, for example, to a plurality of user terminals as push content e.g. to provide a retail offer. For example, a transient agent representing RONALD MCDONALD™ may be transmitted to a plurality of user phones via the network, advertising a special offer relating to MCDONALDS™ restaurants. The transient agent may, at least in part, reside in a storage means on the user terminal. When the user enters a MCDONALDS™ restaurant they can download the transient agent to a MCDONALDS™ portal to obtain the benefit of the special offer. Alternatively, a micro-network in a MCDONALDS™ restaurant could be accessed so that the transient agent can implement the offer over the micro-network. Transient agents may be utilised to implement any number of tasks. They may exist as a "voucher" relating to a special offer, as discussed above. They may also assist or implement other push content, such as straight forward advertising.

From a second aspect, the present invention provides a method of enabling a user of a user terminal in a network environment to carry out tasks, the tasks being

Substitute Sheet
(Rule 26) RO/AU

- 10 -

actioned in the network environment, comprising the steps of implementing in the network environment an intelligent agent which is arranged to carry out the tasks instructed by the user via the network terminal.

5 The method of this aspect of the invention may employ the system discussed above.

 From a third aspect, the present invention provides a user terminal arranged to facilitate implementation of an intelligent agent which is arranged to carry out tasks in
10 response to instructions from a user, the tasks being actioned in a network environment, the user terminal including network interface means for interfacing with a network environment, and agent interface means arranged to provide an agent interface at a user terminal for
15 interaction with the user. The agent interface being arranged to interface with agent implementation means for implementing tasks instructed to the agent interface by the user.

 Preferably, the agent implementation means
20 resides at least in part elsewhere in the network environment.

 Preferably, the user terminal is a mobile terminal for use with a mobile communications network.

 Preferably, the user terminal is arranged to be
25 used with a system as discussed above in relation to the first aspect of the present invention, and may have any or all of the features of the user terminal of that system.

 From a fourth aspect, the present invention provides a computer program arranged when loaded into a
30 computing system connected in a network environment, to control the computing system to implement an agent implementation means for implementing at least in part an intelligent agent arranged to carry out tasks to be

Substitute Sheet
(Rule 26) RO/AU

- 11 -

actioned in the network environment in response to instructions from a user of a user terminal.

Preferably, the computer program is arranged to implement any or all of the features of the agent
5 implementation means of the intelligent agent discussed above in relation to the first aspect of the present invention.

From a fifth aspect, the present invention provides a computer readable medium providing instructions
10 arranged, when loaded into a computer system connected in a network environment, to control the computing system to provide an agent implementation means for at least in part implementing an intelligent agent which is arranged to carry out tasks to be actioned in a network environment in
15 response to instructions from a user.

Preferably, the agent implementation means is implemented in accordance with the agent implementation means discussed above in relation to the first aspect of the present invention.

20 From sixth aspect, the present invention provides a computer program arranged, when loaded into a user terminal arranged to be connected within a network environment, to implement an agent interface means arranged to provide an agent interface at the user
25 terminal for interaction with the user, and arranged to interact with an agent implementation means in order to implement an intelligent agent arranged to carry out tasks within the network environment in response to instructions from the user.

30 Preferably, the user terminal is a mobile terminal arranged to be connected within a mobile communications network.

Substitute Sheet
(Rule 26) RO/AU

- 12 -

Preferably, the user terminal may have any or all of the features of the user terminal discussed above in relation to the first aspect of the present invention.

From a seventh aspect, the present invention
5 provides a computer readable medium, providing instructions for controlling a user terminal arranged to be connected in a network environment, to cause the user terminal to implement an agent interface means arranged to provide an agent interface for interaction with the user,
10 and for interaction with an agent implementation means, for implementing an intelligent agent arranged to carry out tasks within the network environment in response to instructions from the user.

The user terminal is preferably a terminal for
15 use with a mobile communications network.

Preferably, the instructions may implement a user terminal having any or all of the features of the user terminal discussed above in relation to the first aspect of the present invention.

20

Brief Description of the Drawings

Features and advantages of the present invention will become apparent from the following description of embodiments thereof, by way of example only, with
25 reference to the accompanying drawings, in which;

Figure 1 is a schematic diagram illustrating a high level topology of a system in accordance with an embodiment of the present invention;

Figure 2 is a schematic diagram illustrating a
30 topology of the "home" server of Figure 1;

Figure 3 is a schematic diagram illustrating a topology of the "distributor" server of Figure 1;

Substitute Sheet
(Rule 26) RO/AU

- 13 -

Figure 4 is a schematic diagram illustrating an architecture of an intelligent agent utilised according to the system of the embodiment of Figures 1 to 3;

Figure 5 is a schematic flow chart showing operation of an intelligent agent in accordance with the embodiment of Figures 1 to 5;

Figure 6 A and B are screen displays illustrating user interface representations for systems in accordance with further alternative embodiments of the present invention;

Figure 7 is an illustration of the topology of a system "gateway" in accordance with a further embodiment of the present invention;

Figure 8 is a diagram illustrating the general architecture of the embodiment of figure 7;

Figure 9 illustrates the architecture of a JAZZ server utilised to realise the architecture of figure 8;

Figure 10 is a diagram illustrating on-demand RMS provided by the JAZZ implementation;

Figure 11 is a diagram illustrating the connections of the system of the embodiment of figure 7;

Figure 12 illustrates the communication pathway between the agent container and agent gateway of the embodiment of figure 7;

Figure 13 is a diagram illustrating the run time environment of an embodiment in accordance with the embodiment of figure 7 utilising JAVA card SIM;

Figure 14 is a diagram illustrating a menu structure of the user interface in accordance with an embodiment of the present invention;

Figure 15 is a diagram illustrating the object classes of an agent container in accordance with an embodiment of the present invention;

Substitute Sheet
(Rule 26) RO/AU

- 14 -

Figure 16 is a diagram illustrating the architecture of an agent container in accordance with a further embodiment of the present invention, utilising J2ME MIDP;

Figure 17 is a diagram illustrating the run time environment of the J2ME MIDP agent container, and

Figure 18 is a further diagram illustrating the agent container implemented by J2ME MIDP.

Detailed Description of a Preferred Embodiments

10 The following descriptions are of examples of applications of the system in accordance with the present invention, utilising example embodiment systems in accordance with particular preferred architectures. It will be appreciated that other architectures could be used

15 to implement the system of the present embodiment. It will also be appreciated that a skilled software engineer will be able to implement the "means" of the invention (eg. agent implementation means, agent interface, agent interaction means, attribute implementation means, user

20 mood determination means, push content provision means, means arranged to determine the location of the user terminals, agent containers, transient agents), using known software/hardware technology, and a detailed description of their implementation is not given in the

25 following. The following examples particularly relate to an intelligent agent or "creature" implemented by a system in accordance with the present invention, for mobile telephone networks. The particular example given in the first embodiment (Figures 1 to 5) of the tasks the

30 intelligent agent can carry out is taking part in competitions. It will be appreciated that other tasks can be carried out, as discussed above.

Substitute Sheet
(Rule 26) RO/AU

- 15 -

A first embodiment of the present invention will now be described with reference to Figures 1 to 5.

The system of this embodiment is implemented as an on-line service for mobile telephone network customers. It provides operators with the ability to quickly devise and deploy new competitions designed to foster customer loyalty to the network operator and generate increased traffic levels across their networks by utilising the power of Java Card and wireless terminal technology (eg. SMS, IR, BLUETOOTH etc.).

The system implements an intelligent agent which is in the form of a "creature" which appears as a characterisation implemented by the agent interface on the mobile telephone of the user. It may appear as a cartoon type character on the mobile display, for example, and have various attributes, such as nationality, personality, IQ, some of which can be determined by the user and others of which may be determined by operation of the intelligent agent. The intelligent agent can enter competitions in accordance with instructions from the user.

Long term customer loyalty to a network is fostered because:

Competitors know that by using their mobile terminals, they can be rewarded by winning prizes or accepting special offers/discounts and can have fun by solving puzzles and socialising.

Competitions result in the evolution of a virtual creature, (the intelligent agent) that represents the mobile phone user within the world of the wireless network.

Over time, the creature will take on a persona, increased attributes and have the ability to perform tasks

- 16 -

for and on behalf of the network user. Moving from one network to another may result in loss of the character.

Ultimately, the objective is to ensure that the consumer forms an emotional attachment to the character
5 compelling them to support its development and life cycle on a specific operator network.

The network user can inform their creature of what sort of mood they are in (via the mood determination means). This allows the creature to adjust the content it
10 delivers to its owner as well as its style and frequency interaction. Note that mood can be determined in a number of ways. One example is by monitoring the voice of the user. Voice patterns can indicate moods and voice activation/recognition facilities are known and being
15 developed all the time.

For the scenario outlined below, let's call our mobile subscriber "Tony" (the user).

- Let's play...

Tony decides to register for a competition

20 Tony has 3 ways of registering:

The preferred way is for the system (being an on-line service) to send a message for broadcasting to all of the associated operator's subscribers' mobile phones asking if they would like to register. All Tony would need to do is
25 respond to the broadcast message.

He may call his network operator's competition support line and ask the operator to enrol him for the competition.

Tony may send a message from his mobile phone to a
30 dedicated number for competition registration.

Tony decides to register by creating a message on his mobile phone that reads "Register Tony", enters the number

Substitute Sheet
(Rule 26) RO/AU

- 17 -

he was given for competition registration and sending the message

Tony is now registered

5 • Hi Moby!

Tony receives a message on his mobile phone - the agent interface is downloaded by the system to the mobile phone, in this example the agent interface is downloaded in the form of a Java Applet which can be downloaded to
10 the SIM Card of the mobile phone. The Applet provides a characterisation of the "creature" on Tony's phone as well as an interface via which Tony may communicate with the creature.

The creature is now on Tony's phone. It lives there,
15 it represents him, it works for him, it moves in the wireless network - it's Tony's friend!

• Inseparable...

Tony and his creature are now partners learning, playing and socialising together

20

• Learning together

Tony selects the "Learning" option

Tony can now provide the creature with various attributes.

Tony can now personalise his creature - he gives it a
25 name

He can give it a personality - he gives it an age, selects the type of creature he wants, its nature, selects a nationality and a star sign. These attributes are used
30 socialising.

• Playing together

Tony selects the "Play" option

Substitute Sheet
(Rule 26) RO/AU

- 18 -

He picks the "Find Competitions" option. The creature is then dispatched to the network to find out what competitions are available for Tony to enter in. the creature returns to Tony's phone and presents him with the
5 available competitions.

Tony selects an option to join an available competition. The creature goes up to the network and enrolls him into the competition. It brings back the options for the competition. In this case, the only
10 option is to solve a puzzle.

Tony selects this option.
A message is presented to Tony asking him when the Sydney Opera House was opened.
Tony enters "1974" into the entry field provided and
15 selects "enter".

Tony receives a message telling him that he is correct, that he has scored 10 IQ points and that he needs 50 more points to enter the competition draw. "IQ" is in this case a further attribute of the creature which can be
20 adjusted during creature carrying out tasks such as entering competitions (as in this case). If the IQ attributes keeps increasing, until it reaches 60 points, the creature will then enable Tony to enter a competition draw.

25 Tony selects "Next"
A promotional message comes up saying:

That puzzle was brought to you by City Honda - your one stop shop for Honda cars". Push content provision means (which could be a connection to an advertising
30 server) provides such promotional messages.

- Socialising together

Tony can send his creature away to meet other creatures (mobile users) in the virtual world.

Substitute Sheet
(Rule 26) RO/AU

- 19 -

Tony can attach messages for his creature to give to other creatures (mobile users)

Tony can tell his creature what sort of creature his creature should try to meet. In this way, Tony can meet
5 with users on the mobile network and can exchange messages with them via their creatures or, on request from the creatures he meets them (similar to a party line style of environment), by exchanging mobile phone numbers and calling each other. The creatures may select whether or
10 not they are "compatible" by comparing their attributes.

- Winning together

The system broadcasts advertising and promotional messages to creatures.

15 Tony's creature passes on advertising and promotional messages it has received to him.

Tony chooses to reply to a promotional message that interests him allowing him to go onto the promoter's mailing list or call the promoter directly.

20

While the above example is one example of a possible competition that can be run by an operator, the creatures developed by contestants live longer than any one competition. In this way, the more competitions that a
25 contestant enters, the more valuable their creature becomes (by changes in attributes) and the greater chance they have of winning.

New competitions may be designed to enhance different attributes of the creature. The first is IQ, another may
30 be related to appearance, nature etc.

A creature may be able to interact in a way that takes its owner's personal preferences and current mood

Substitute Sheet
(Rule 26) RO/AU

- 20 -

into account thus making the creature even more valuable to its owner at a more personal level.

These creatures may become virtual, personal companions that live on the mobile terminal. The user's terminal is provided with a security means, utilising technology such as RSA and X509, ensuring that the device is secure and also ensuring that operation of the intelligent agent is secure. The intelligent agent becomes a trusted personal companion associated with the particular user.

One of the key concerns for wireless network operators today is network churn, that is, the proportion of the operator's subscribers who switch over to a competitor. Research has shown that the average churn for an operator is 30% per year and the cost of acquiring a new subscriber is \$300. If an operator with 2 million subscribers could drop their churn rate from, say, 30% to 25%, this would save them \$30 million annually.

The system in accordance with the present embodiment may offer personalised over the air promotions that foster customer loyalty and lower network churn.

This embodiment is attractive to GSM operators as its primary focus is on operating and managing a personalised marketing activity that has the potential to create long term customer loyalty and lower network churn for the operator.

The web is an integrated part of the competition environment allowing the operator to use the web as a marketing vehicle as competitions are promoted and then run.

In addition, cross promotional activities can be run by attaching "advertisements" to puzzles as they are delivered (by the creature) to the competitor. The

Substitute Sheet
(Rule 26) RO/AU

- 21 -

competitor may also be given the option of responding to advertisements (eg. go onto a mailing list). In this way, it may be free for a consumer to participate in a competition if the advertising is used as a revenue
5 generation activity for the operator.

Through the development of strongly branded "creatures", the operator can leverage the marketing appeal of these creatures through related activity (eg. games, character branded products, advertising etc.).

10

With the system of this embodiment:

- Advertisements and promotions are more effective as they are delivered to the mobile user directly on their phone, users can respond to them easily and they are
15 delivered in the context of a fun and rewarding environment (a competition via their creature).
- It provides an environment where direct and one-to-one marketing techniques can be applied much more effectively.

20

The system may also appeal to subscribers who register for competitions as they will:

- Have fun with their mobile terminal in new, innovative ways
- 25 • Be rewarded for using their mobile terminal by winning prizes
- Be able to socialise with other competitors by:
sending their creature into the competition space to meet other creatures of a specific type (eg. common
30 interests) and exchange attached messages or exchanging mobile numbers (optionally enabled by a competitor to protect their privacy)

- 22 -

- Feel comfortable that their creature will interact with them in a way that suits their personal preferences and current mood.

5 The system of this embodiment is designed from the outset to be as user friendly as possible for the mobile subscriber. The level of user friendliness is obviously constrained by the mobile terminal's screen size, functional capabilities and user input options.

10 From their first interaction with the service, the subscriber need only reply to a simple broadcast SMS message to register for a competition. The process for selecting a creature is again very straightforward requiring minimal input.

15 The subscriber then interacts with their creature through their mobile terminal using a simple and intuitive menu system, predefined option lists and minimal field input. The user friendliness is raised to a new level by providing the subscriber with the option of telling their
20 creature what sort of mood they're in. The creature is therefore more "user aware" and can adjust its interaction style accordingly eg. using less/more aggressive approaches to informing the subscriber of special offers, increasing/reducing the frequency of advertisements,
25 screening/passing messages from particular types of creatures.

 Technical implementation of the system in accordance with the present embodiment is designed to promote the "mobile" code aspect of Java (eg. through the mobility of
30 the creature in the competition environment) and the value of this aspect when Java is available on a mobile terminal via a SIM Card. It is also designed to promote the evolutionary nature (eg. via progressively evolving

Substitute Sheet
(Rule 26) RO/AU

- 23 -

creatures) that Java applications can take in a deployed, large-scaled networked environment.

Referring to figure 1, the system in accordance with this embodiment of the present invention comprises three
5 key components. Namely, a home portal server 1, a distributor 2 and the creature Applet which is resident on the user's Java SIM enabled mobile phone.

The Distributor 2 resides at the GSM operator's premises 5 and is responsible for connecting the mobile
10 network 6 (via an OTA server 7) to the home server 1. The connection (optionally VPN-based) from the Distributor 2 to the home server 1 carries HTTP traffic back and forth. The home server 1 is responsible for hosting the competitions and also the operator's portal where
15 competitors can get access to the competition web pages.

In essence, a Creature is routed up and down the line from the consumer's mobile phone 4, to the home server 1, via the Distributor 2.

The home system 1 is a Java server-based web service
20 that hosts multiple competitions for one or more network service providers. They are able to run/manage their competitions from their web browser by accessing the Site Administration Console 8. The home system 1 also allows network service providers to store and manage the
25 promotional content developed with and/or provided by their advertising, promotion and direct marketing partners.

The home system 1 provides secure HTTP connections to multiple Distributors over which traffic (such as
30 serialised creatures and advertisements) flows back and forth. It also provides a http connection for general web traffic, primarily for mobile subscriber access to their

Substitute Sheet
(Rule 26) RO/AU

- 24 -

network service provider's web portal (which also resides on home system 1).

The Distributor 2 is a Java server component that sits on a server at the operator's premises connecting the consumer, via the operator, to the competition's hosted at the home system 1. It does this by connection to the OTA server, converting and then forwarding objects (such as serialised Creatures) back and forth between the consumer's mobile phone 4 and the relevant competition on the home server 1. The Distributor 2, is managed from home server 4 via the Distributor Administration Console.

Due to the fact that there are objects roaming the network (mobile phone to Distributor to home server and visa versa), a synchronous architecture has been developed. This architecture is also well suited to an SMS bearer. Two mechanisms exist at the heart of the architecture:

- HTTP based delivery of serialised objects between Distributor at a network operator and home system
- A queue-based system in the distributor to enable object (Creatures) to be collected and dispatched (synced) as required to and from the mobile.

Because a queue-based system is employed, load balancing can be easily effected when distributors are deployed. Multiple OTA services can be run to process objects held in the Object Dispatcher, each attached to different OTA Servers (SMSCs). Given that the Distributor acts as gateway between the consumer and the home server, it can interface with the network service provider's subscriber management and billing functions.

The Creature Applet 3 is a Java SIM Toolkit compliant Java Card applet that resides on the consumer's Java SIM

Substitute Sheet
(Rule 26) RO/AU

- 25 -

enabled mobile phone. It works by sending and receiving requests/responses packaged up as SMSPP commands to and from the OTA service. Since most of the intelligence is built into the Creatures, Advertisements, Puzzles and
5 other objects that move backwards and forwards between the Distributor and the home server, the Creatures Applet is simple in its design and quite small in size.

All objects that are distributed between the mobile, distributor and home are transportable, syncable objects.
10 This means that they have the ability to move from the distributor to home and visa versa, and in the course of moving over the network, collect information that needs to be provided to the applet on the phone. When an object (eg. a Creature) collects information, each element of
15 information is recorded as a transaction. Once the object has finished collecting it is queued in the distributor's object dispatcher. An OTA service then polls the distributor's object dispatcher looking for objects to dispatch back to the mobile.

20 When one is found, the OTA service tells the object to "sync" itself with the applet on the mobile. The object then goes through its transaction queue and sends each transaction to the applet to be processed.

Advertisements can be broadcast from home to all
25 mobiles that have the Creatures Applet on them. Advertisements are broadcast as follows:
When a distributor starts, it registers with home
When an advertisement is to be broadcast, an Advertisement Object is dispatched to all registered distributors
30 A distributor then iterates through each OTA Service running on it, instructing each service to put the object (advertisement) in a broadcast queue

- 26 -

When an OTA Service is "polling" for new objects to dispatch (sync) to the mobile, it periodically looks in the broadcast queue to see if there are any objects to be dispatched (synced) to all mobiles. If there are, then
5 the OTA service will iterate through all mobile numbers for which it is responsible and ask the broadcast object to sync with that number

In this way, 1 advertisement can be sent from home to a single distributor and then that advertisement can be
10 broadcast from the distributor to all mobiles connected to it.

The compactness of applets that will reside on a Java SIM is a very important design and implementation consideration given the small footprint and dynamic nature
15 of applets that will reside on the SIM at any one time. We were able to keep the size of the Creatures Applet small by:

- Ensuring most of the required Creature and attachment (eg. puzzles, advertisements) intelligence relating to
20 how they worked, how they were collected and dispatched resides on the Distributor and/or the home portal server and not in the applet
- Storing most of the required data regarding a Creature on the home server.

25

In fact the Creature Applet is no more than a presentation of what happens in the network and holds very little information. The approach also provides more flexibility as none of the Creature (or attachment)
30 behaviour is hard coded into the Creature Applet. This removes the need for costly, time consuming and bothersome downloads of new applet/class versions to the mobile phone to support new creature/attachment capabilities.

Substitute Sheet
(Rule 26) RO/AU

- 27 -

While security is not of paramount importance to our application (primarily a simple broadcast environment with mobile users sending and receiving messages), security is still quite a prominent feature of the system service from
5 the home server to the Dispatcher to the consumer's mobile phone and back again.

First and foremost, the Distributor resides at the operator's secured premises enabling the Distributor to safely connect and communicate with the operator's OTA
10 server. The operator has the option of a VPN connection to the location where the competition is hosted and the related competition content resides. It is also possible for us to encrypt the objects that are shuttled back and forth hence adding another layer of security over an
15 already secure connection.

Security in the applet loading process is achieved by the encryption and signing of the applet code (using the Triple DES algorithm in the case of the Bull SIM Rock'n Lab/Rock'n Tree card) prior to having it loaded onto the
20 consumer's mobile phone.

Security is also provided, as discussed above, by the security means ensuring that there is little chance of another person being able to use the intelligent agent.

Although in the above architecture the majority of
25 the "intelligence" of the Agent does not reside on the phone, it will be appreciated as mobile technology progresses, it may well be possible to provide a more distributed system having far more intelligence resident on the user's terminal.

30 The particular embodiment described but relates to a system from filing an intelligent agent particularly for use with mobile communication devices. This preferably include mobile telephones or small computing devices such

Substitute Sheet
(Rule 26) RO/AU

- 28 -

as palm-top computers which have a facility for communicating via a mobile network.

It will be appreciated, however, that the system of the present invention may be implemented for stationary
5 devices such as PCs utilising land-line communications to networks.

In the embodiment described above, the main task for the intelligent agent is to enter into and take part in competitions. As discussed in the preamble of the
10 application, there are many other tasks in which the system of the present invention can carry out, however, the system is not limited to competitions.

As discussed above, the intelligent agent can carry out many tasks apart from taking part in competitions.
15 For example, the intelligent may interact with systems installed in retail locations. For example, an intelligent agent user is walking down the street and passes a coffee shop. There is a particular coffee type that the user likes and the user wonders if the shop has
20 it. The intelligent agent understands that the user enjoys this particular type of coffee because he has been told this by the user previously. The intelligent agent goes from the mobile telephone (using low power RF network, such as BLUETOOTH™, and a micro-server in the
25 coffee store) to the coffee shop and enquires about the coffee. When the intelligent agent returns to the mobile, he tells the user that the shop has the desired brand of coffee, and, in addition, he has a voucher for the user that says that "if you buy a coffee today, you will get a
30 free muffin".

The intelligent agent is therefore preferably able to move over such close proximity networks (preferably it may move over many different types of networks), as discussed

Substitute Sheet
(Rule 26) RO/AU

- 29 -

above, interacting with other systems, such as servers in retail locations.

A further embodiment of the present invention will now be described with reference to figures 6 through 18.

5 This embodiment is a modified embodiment in which the functionality of the home portal server and distributor (figure 1 of the above embodiment) are combined into a single "agent gateway" under control of the network operator. Further, in this embodiment, the system can
10 operate with a number of different "clients" having different facilities on their mobile devices e.g. SMS, WAP, etc.

The heart of the system of this embodiment resides in the server technology, called "Agent Gateway". The client
15 technology (the Agent Containers) exists to allow agents to "appear" visually on a handset.

The agents ("creatures") are the best friend of the wireless consumer. They live on and move around the mobile network performing tasks on behalf of their owner,
20 the consumer.

Creatures have a personality and in the case of a Java enabled phone, a visual appearance.

The user uses their mobile phone to communicate with the creature via the agent gateway.

25 In some cases, it is possible for creatures to live on the consumer's mobile device. This is possible if the mobile device is Java Card SIM or J2ME enabled. For a creature to reside on a mobile device, the device must support the system agent container. In the case of a Java
30 Card SIM mobile, the agent container is an operator certified Java Card SIM Applet. In the case of J2ME, the container is an operator certified midlet that is permanently resident on the mobile device. The agent

Substitute Sheet
(Rule 26) RO/AU

- 30 -

container may be installed by the operator "over the air" when the consumer subscribes to the operator's agent service.

In the case of an SMS, WAP, HTML or email deployment
5 of the agent gateway, the consumer's creature lives completely within the agent gateway.

However, even in the case of the Java Card SIM and J2ME forms, the vast majority of the agent functionality resides at the gateway. The Java Card SIM and J2ME agent
10 containers are mechanisms to allow the agent to be presented as "living" on the mobile device. Accordingly, in the first instance, the agent container should be seen as an "agent browser" that has the capability to graphically display the state of a creature to the
15 consumer.

Figure 6 illustrates screen representations driven by the Java Card SIM and J2ME agent containers (reference numerals 100 and 101 respectively).

Consumers "talk" to their agent. Currently this is
20 via text entry. In the future, consumers may talk to their agent using voice.

In the case of an SMS deployment, consumers talk to their agent by sending SMS messages to a phone number that represents their agent. The agent responds by sending SMS
25 messages back to the consumer.

There are two types in this embodiment - personal and transient. The personal agent is the consumer's "best friend". Only one exists per mobile and it only expires if the consumer leaves the operator network.
30 Alternatively, transient agents have a short life span and are collected by the consumer using their agent container. Transient agents can be broadcast over the network to using the Talking Point Agent Broadcaster. As transient

Substitute Sheet
(Rule 26) RO/AU

- 31 -

agents are held in the agent container, and therefore, are only possible in the Java Card SIM and J2ME deployment formats.

A transient agent in one example is a discount
5 voucher, which can broadcast over the wireless network to the mobile device. The voucher appears in the agent container as a "branded" voucher (e.g. one of the characters that MCDONALDS™ is promoting at the time i.e. A toy Story character if they are promoting Toy Story Happy
10 Meals). The consumer can redeem the voucher over a micro network e.g. a BLUETOOTH connection at a store using their mobile and the agent container. The transaction is kept secure and is managed using the facilities of the container and the agent gateway.

15 Agent implementation is via the agent gateway which is connected to the operator network and located at the operator's premises.

The agent gateway delivers the functionality necessary for an operator to create agent-based services
20 and deliver those services over its network using "character" based agents.

Figure 1 illustrates the key components of the agent gateway 103, client connectors 104, core services 105, content actions 106.

25 When an operator deploys the system they determine the ways in which they want their consumers to be able to "talk" to their agents. The system supports a number of "conversation" options. Each deployment option is termed a "connector" as it facilitates a connection between the
30 consumer and their personal agent. The default connectors provided are:

Short Message Service (SMS) consumers talk to their agent by sending/receiving SMS messages.

Substitute Sheet
(Rule 26) RO/AU

- 32 -

Java Card SIM - the creature appears in the phone menu system. Consumers talk to their creature by selecting the actions from the menu, conversing with the agent in the same way as they converse with a friend over
5 SMS.

Java 2 Micro Edition MIDP - the creature appears on the phone in a fully graphical manner. They are animated and converse with the consumer in a textual manner. They may converse using direct speech entry and generation.

10 WAP browser - consumers access a WAP page to converse with their creature. They converse via text entry.

Web browser - consumers access a HTML page to converse with their creature. They converse via text entry. In the future, an applet version of the creature
15 will be supported to allow the consumer to interact with their creature in the same way as they would with a J2ME MIDP creature.

Internet based email - consumers converse with their creature by sending/receiving emails. The creature can
20 also initiate a conversation with their user by sending the user an email.

iMode/iAppli - consumers converse with their creature on an iMode and/or iMode + J2ME enabled phone (planned).

Desktop - consumers place a version of their creature
25 on their desktop and converse with it as an interactive application (planned).

The core services gateway 103 provide an environment where the agents live and interact (MorphenCentral), allow the agent environment to be managed (administration) and
30 ensure that data cached on J2ME MIDP devices is seamlessly backed up and restored on demand ensuring that the data is not lost when the handset is lost.

Substitute Sheet
(Rule 26) RO/AU

- 33 -

However, without contents actions 106, the agent environment would not provide a compelling experience for the consumer. The connectors and core services do allow the consumer to talk with their agent but the agent could not perform more meaningful tasks if it didn't have access to content actions.

Content actions are the mechanism by which an operator integrates specific "content", leveraging the existing and developing relationships for their wireless portal.

For example, one content action 106 may be ticket master 107. The agent can utilise the ticket master 107 content action in order to purchase tickets from a designated venue. For example, if a user wishes to purchase tickets from a particular cinema, ticket master would be employed together with an application program interface (API) at the theatre box office in order to enable the agent to obtain the tickets. Any number of content actions may be included and some examples are shown in figure 7. For example, with a "phone book" 108 can provide a list of phone numbers which the agent can fetch when queried by the user asking for a particular name (i.e. the agent fetches the right phone number).

If the user is using SMS to talk with their creature, the creature does not have a visual appearance - it is perceived by the user to be living on the wireless network. Java Card SIM helps create the appearance that the creature lives on the wireless device by supporting access to the creature through the phone menu structure, but it is not until J2ME MIDP devices are in play that the user will believe that the creature is a living creature on the device.

Substitute Sheet
(Rule 26) RO/AU

- 34 -

Ultimately, the best way to interact with a creature is using voice commands and response through the wireless handset. This will be possible using the evolving voice recognition capabilities of the handsets, and server side
5 technology such as Motorola's VOXML gateway.

In one preferred embodiment, the system is implemented in Java. The server platform can be run in any environment supports the Java 2 Runtime Environment (J2RE), versions 1.2.2. or later. The client technology
10 requires either:

A Java Card SIM enabled handset, or a Java 2 Micro-Edition (J2ME) Micro Information Device Profile (MIDP) enabled wireless appliance.

To support the various connectors, a number of 3rd
15 party technologies are packaged with the distribution:

SMS - a portable Short Message Server is provided to support SMS connectivity over the air. To run the portable SMSC, a Nokia phone card and a BTI CardAPTOR⁸ is required.

20 Java Card SIM - to support over the air connectivity with a Java Card SIM enabled device, a Java Card SIM connector for the AU Systems OTA server is provided. Due to the constraints of the underlying AU Systems interface, this connector may only be run on Windows NT or Solaris.

25 Internet Email - to support connectivity with an Internet email server a POP email connector is provided using the Java Mail API.

Figure 8 presents the technical architecture for the system of this embodiment.

30 The system is build using an internal Java Wireless Application Server, called Jazz. This application server provides the basic building blocks to realise the "service" based architecture for the agent environment.

Substitute Sheet
(Rule 26) RO/AU

- 35 -

There are two sides to the System product suite:
Wireless Client Technology and Agent Service Platform.

The client technology is the agent container that can
be installed on J2ME MIDP and Java Card SIM clients.

5 The service platform is an Agent Gateway that uses a
natural language engine NLE, an agent broadcaster (which
can send transient agents to the agent containers), a set
of agent tools to help construct agent services and a set
of pre-packaged agent services that help an operator to
10 get up and running quickly.

The system has been developed using an internal Java
wireless application server. This application server is
called "Jazz". It's architecture is illustrated in Figure
9.

15 Features of Jazz include:

A service based distributed application architecture;
An inbuilt lightweight HTTP server;
Support for MIDP client/server application deployment (a
lightweight windowing framework, a persistence framework
20 support on-demand caching/backup of RMS MIDP data and a
high level framework supporting HTTP based client
connections from MIDP devices);
A content framework designed to support delivery of
content of varying types (text, HTML, WML);
25 A set of general utility classes (e.g. to support loading
and saving of configuration data etc.), and
A set of general widget classes to simplify GUI
development (e.g. an Outlook style bar).

Jazz promotes the use of a "distributed service-
30 based" architecture. This means that server side
applications are developed as "services" that are run in a
Jazz Server. Multiple serves may be run across
processors, each executing different services that

- 36 -

inherent have the ability to communicate between each other (using RMI).

To illustrate how a wireless server application is constructed using Jazz, let's walk through an example.

5 Consider the following:

We are building a simple Stock Market client/server application. The server side application will support wireless web (HTML and WAP) browsers and a standalone MIDP application (on a wireless J2ME MIDP device). For the
10 sake of simplicity, we will illustrate how a "stock quote" function may be implemented using Jazz (e.g. get current price for Nokia (NOK)).

The first step to creating this wireless application is to design how the service will work. The key design
15 points for our example are:

Both the browser and the MIDP applications can use exactly the same interface on the service to get a quote on a stock. That interface could be: getQuote (String stockcode).

20 In the case of a WAP client, this function should return a WML page that displays the stock code and the current price. For a web browser, it should return a HTML page, while a MIDP application will just require a text string with the price which it will then display using the
25 graphical components of Java (e.g. as a label in a panel).

To help the service understand the type of content it is to return, an extra parameter will be passed to the getQuote method, one that will specify the content type to return. So the final interface could be: getQuote (String
30 contentType, String stockcode).

To support the concept of different content types being returned from a Jazz service, Jazz supports the notion of a content set, which is a set of classes that

Substitute Sheet
(Rule 26) RO/AU

- 37 -

support streaming various content types back to a client application.

Implementing a Jazz service is very similar to implementing an RMI service the only exception is the classes that are used. To implement a server side service to support the Stock Market application, the following steps are taken:

Implement a service interface;
Implement the service itself.

10 To implement the service, the following code will be placed in a file called StockMarketServiceInterface.java:

```
import com.cardventures.jazz.content.*;
public interface StockMarketServiceInterface implements
com.cardventures.jazz.service.RemoteServiceInterface {
15 public TextStream getQuote (String contentType, String
stockCode) throws RemoteException;
}
```

The points to note in this interface definition are our getQuote method is defined to return a TextStream, which is the base content type for all content types (WML, HTML, HTTP etc.). As is the case in RMI, all public methods in a Jazz service throw a RemoteException that will need to be caught by the application calling the Jazz service.

25 To implement this interface, we will define StockMarketService.java as follows:

```
import com.cardventures.jazz.content.*;
public class StockMarketService extends
com.cardventures.jazz.service.RemoteService implements
30 StockMarketServiceInterface {
public StockMarketService(){
Super();
SetName ("Stock Market Example");
```

Substitute Sheet
(Rule 26) RO/AU

- 38 -

```

    SetVersion ("1.0");
    SetBuild ("1");
  }
  public void startService(); throws RemoteException {
5   super.startService();
  }
  public void stopService() throws RemoteException {
    super.stopService();
  }
10 public TextStream getQuote (String contentType, String
    stockCode) throws RemoteException {
    try {
      TextStream content =
      ContentFactory.createStream(contentType); content.add("NOK
15 41.25"); // static example
    }
    catch(ContentCreationException e) {
      trace *e.getMessage();
    }
  }

```

20 When implementing a Jazz service, the following standard methods must be implemented:

 Constructor: always call super () as the first thing in the constructor. After that, initialise your service, and it is recommended that part of this initialisation
25 process include setting the service name, version number and build identifier using setName(), setVersion() and setBuild() respectively.

 startService: (optional) - startService is always called when the Jazz Server starts the service. If you
30 override the default, always call the standard implementation first. Place any service initialisation statement in here, especially if you need access to the

Substitute Sheet
(Rule 26) RO/AU

- 39 -

service configuration data (via getConfig()) as it will be available at this time.

stopService: (optional) - stopService is always called when the Jazz Server stops the service. If you
5 override the default, always call the standard implementation first before executing any local cleanup code.

Within the getQuote method, we create an instance of the content stream that we require using the
10 ContentFactory class.

To add information to a content stream, the add method is used on a content class. This results in the new information being appended to the data currently held by that content class.

15 The respective content classes will add the required headers to the content data to ensure that the content is safely transmitted over the wire to the client application.

The Jazz server will first construct an instance of
20 the service, then it will force the service configuration data to be loaded, before registering the service with the RMI registry. Once this process is complete, it will then call startService() to allow the localised service initialisation process to be completed.

25 When a service is stopped, stopService() is called first by the Jazz server before deregistering the service with the RMI Registry.

Once the service has been implemented, it needs to be compiled before it can be run in the Jazz server. To
30 compile a Jazz service, RMIC needs to be used to create the RMI stubs and skeletons for the service. Remember, all Jazz services are implemented as RMI services.

- 40 -

To compile a Jazz service using RMIC, use the following commands:

```
javac -d $ (OUTPUT)
      -classpath "$(OUTPUT):$(JAZZ):."
5      *.java
rmic -d $(ROOTDIR)classes
      -classpath "$(OUTPUT):$(JAZZ):."
      -sourcepath $(PROJECT)
      StockMarketService
```

10 Where:

\$(OUTPUT) is set to the directory where the compiled classes are to be placed;

\$(SOURCE) is the directory where the source files are located;

15 \$(JAZZ) is the location of the Jazz distribution archive (jazz.jar).

Building a J2ME MIDP Application using Jazz

Jazz includes a number of packages designed specifically to support seamless applications development on a J2ME MIDP device. These packages include a lightweight windowing framework mirroring AWT and a simple frame work to support on-demand back-up/retrieval of RMS cached data (the data is backed up and retrieved from the a server side service).

20

25

All wireless J2ME MIDP devices face a similar problem - when the device is lost, data stored locally by a MIDP application within it's Record Management System (RMS) will be lost, unless it is backed up onto the network in some way.

30

The Jazz On-Demand Record Management System API provides a seamless mechanism to backup all local data to a server accessible via the wireless network.

Substitute Sheet
(Rule 26) RO/AU

- 41 -

When designing the API, the following requirements are taken into account:

The process of accessing data that is backed up must be seamless to a MIDP application in that it must be just as easy to get a piece of data from the standard MIDP RMS as it is to get it from the On-Demand RMS;

A MIDP Application must be able to specify if a piece of data to be held in the RMS is to be backed-up or not;

A MIDP Application must be capable of getting a piece of data directly from the back-up store on the network, bypassing the local store, but the API must be the same;

If the value of a data item stored in the back-up RMS changes and is specified to be up-to-date with any copy cached on the handset, the change is to be propagated back to the handset.

Figure 10 illustrates the On-Demand RMS.

Jazz provides an enhanced RMS class on the handset that extends the standard RMS to provide connectivity to a network bound, backup RMS server.

A MIDP application requests a data item from this extended RMS. IF the data item is available locally because it is being held in the local RMS. IF the data item is available locally because it is being held in the local RMS, it is returned immediately. If it is not available, it is retrieved from the data warehouse on the network and cached before being returned. The application can specify that the data item should not to be cached if retrieved from the data warehouse. Additionally, when a data item is cached, the data warehouse can be told to keep the data item up to date if the value changes in the data warehouse while it is cached.

The standard MIDP RMS has a very restricted capacity on the handset. This means that data will be moved in and

- 42 -

out of the RMS as the capacity is reached. The On-Demand RMS uses a FIFO (First In, First Out) strategy to determine which data items should be removed from the cache to make room for more recently requested data items.

5

The Agent Gateway

The agent gateway is the heart of the system service environment. It provides a home for talking point creatures, allowing them to live and move. It also provides the intelligence for creatures in the form of a natural language engine and integrated agent content.

The gateway is built using the Jazz Application Server, and as such, adopts the service model that it promotes.

As illustrated by figure 11, the gateway connects users to their creatures.

Users send natural language requests to their creatures. If the user has a wireless device supporting J2ME MIDP or Java Card SIM, it will appear to the user that their creature lives on the device, but in reality, the creature resides in the gateway. The container simply provides the perception that the creature is on the phone while in the background the container formats and passes instructions to the creature living in the gateway.

When a creature performs an action it completes a transaction.

The gateway supports three types of creature transaction - immediate, delayed and uninitiated.

An immediate transaction is one that is initiated by the user (by instructing their creature to perform an activity) that results in the creature completing the request before returning the response immediately - for example, "what price is NOK trading at?".

Substitute Sheet
(Rule 26) RO/AU

- 43 -

Alternatively, a delayed transaction is one where an instruction is issued triggering the creature to think a while before it can reply - for example, "tell me when NOK trades above 50".

5 An uninitiated transaction does not involve the user instructing the agent. The creature performs the action itself and updates the user accordingly - for example the creature asking the user "How are you feeling today?".

10 Agent Containers

While it is possible for a wireless client to communicate with a creature without the aid of any additional software on the client, the use of an agent container on the client has the capability to enhance the
15 experience for the user.

Additionally the use of an agent container introduces the user to the notion that the agent actually lives on the wireless appliance;.

In the case of the Java container, it allows the
20 agent to take on a dynamic visual form.

Over time, the agent container can be extended into a secure container that has the capability to store redeemable vouchers (called Transient Agents) and other "collectible" items.

25 Two types of agent container are supported - Java Card SIM and Java 2 Micro-Edition Mobile Information Device Profile (J2ME MIDP).

An agent container can be viewed as a simple browser for an agent - it provides the ability for an agent to
30 display itself on the handset.

The container to gateway communication pathway is illustrated in figure 2.

- 44 -

Regardless of how complex that display facility may be, the connection between the agent container and the gateway is a simple one. All communication between the agent container and the agent gateway is centred on the transfer of "natural language requests" (e.g. how are you today?) so it is a primary responsibility of an agent container to get the conversation from a user and transfer it to the gateway for processing by the creature (and NLI) that runs there.

10

Java Card SIM Container

The Java Card SIM Agent Container is a Java Card SIM Toolkit application.

To deploy the application, the Java Card SIM container requires a Java Card SIM Applet that is installed onto a Java Card SIM in the wireless handset, and a Java Card SIM Connector that supports a line of communication between the gateway and the Applet on the SIM in the handset.

20 The Java Card SIM container is compliant with the Java Card SIM standard, and the SIM application toolkit standards (complying to GSM release 11.14, 11.11; 3.40 and 3.48).

From an architectural perspective, figure 13 illustrates the runtime environment components on a Java Card SIM handset.

The components of this environment include and operating system compliant to ETSI 11.11;

A Java Virtual Machine compliant to the Java Card 2.1 specification;

30 The Java Card API to provide support for the implementation and runtime execution of the Java Card compliant applets;

Substitute Sheet
(Rule 26) RO/AU

- 45 -

An API to support the implementation of SIM Toolkit oriented Java Card Applets. This API is compliant to the ETSI 03.19 standard, and

The Java Card SIM applets. In this case, the agent
5 container.

When the Java Card SIM agent container is installed, it appears as an integrated element in the wireless applicant's menu system. A user accesses their Java Card SIM creature by navigating the menu system, selecting "My
10 creature" and then the desired function. An example menu is illustrated in Figure 14.

There are several advantages to the Java Card SIM creature over a standard SMS based creature. The Java Card SIM creature:

15 appears to live on the phone because it is an integrated part of the phone menu system. Menu driven operation enhances the user experience by improving useability, principally speed of operation via menu driven operations that short-cut the laborious process of SMS
20 style text entry;

has access to information stored locally on the wireless application - principally contact and calendar information, along with ring tones. This allows the creature to behave in a more intelligent manner, appearing
25 to "know" details about the user. It also reinforces the view that the creature "lives" on the phone.

The Java Card SIM applet is designed to enhance the experience for the user as they "converse" with their creature. To achieve this, the container provides the
30 following functionality:

Talk: Provides a mechanism for the user to "converse" with their creature. This mechanism operates in an identical manner to sending/receiving short messages on a mobile.

35 History: To provide quick access to the last five conversation points, a history is maintained. Conversations maintained in history may be accessed and

Substitute Sheet
(Rule 26) RO/AU

- 46 -

sent to the creature, reducing the amount of text entry required to converse with the agent.

Favourites: In a similar vein to the history option, certain types of conversations will occur frequently
 5 between the user and their creature. This option records the "top 5" conversation points, allowing easy access to the text so that it can be quickly sent to the creature for processing.

Socialise: creatures can meet other creatures and
 10 exchange messages, and they can help organise events for their owner by sending invitations (by SMS) and processing replies (SMS messages).

Play: creatures are fun - they can play games and enter competitions. This function reinforces that view,
 15 allowing the user to increase the value of their creature by accumulating loyalty points. Loyalty points may also be accumulated in the course of a conversation using the "talk" function.

The Java Card SIM Agent Container is a reasonably
 20 simple application. It is primarily responsible for providing a menu system, some input functions and sending/receiving messages.

Figure 15 presents the classes that make up the container.

25 Chatterbox is the main class, derived from the `sim.toolkit.ToolkitApplet`.

Implementing a Function

Each function provided by the Agent Container is an
 30 implementation of the Function class. The function class provides the basic mechanisms needed for a function to operate:

Executing a function by sending and processing short messages sent to and from the gateway;
 35 Holding a menu name and sub-menus;
 Processing a menu select request;
 Displaying text;

Substitute Sheet
 (Rule 26) RO/AU

- 47 -

Processing text input;
Obtaining the location and time identifiers.

Location and Time Sensitivity

- 5 The Function class provides methods to obtain the location and time identifiers and stamp those identifiers in a conversation instruction when it is sent to the Agent Gateway. This allows the creature to identify the location of the user and the time that the conversation is
- 10 taking place.
- The methods provided by the Function class are:
 getLocation() - obtains identifier from the wireless appliance. At this time, it is the cell ID, which is mapped to a location by the gateway; and
- 15 getTime() - obtains the date/time from the wireless device.
- When an instruction is processed and dispatched by a Function to the gateway, the location and time information is always prepended to the instruction.
- 20 This location and time information can be used when executing content actions. For example, the user could ask for the location of the closest movie theatre and, utilising the geographical information provided,? could provide that location.
- 25 When a creature processes an instruction on the gateway, it may result in a change to the level of loyalty points that a creature may have. The <loyalty value="change"> tag in MAIML supports this type of operation.
- 30 As the Java Card SIM agent container holds the loyalty total, this total needs to be updated if a change occurs. When an instruction is dispatched from the Gateway to the Agent Container, the instruction takes the form:
- 35 [FUNCTION ID] [DATE]
 where FUNCTION ID is the identifier for the function that this response is applicable to; while DATA is the data to

apply to the function.

The first element of the DATA block is always a [LOYALTY COUNTER] which is processed by the container to ensure that the loyalty total is up to date.

5

J2ME MIDP Container

The Java 2 Micro-Edition (J2ME) Micro Information Device Profile (MIDP) Agent Container is a Java application that runs on a wireless handset.

10 To deploy the application, the container requires a handset that supports the J2ME Java Virtual Machine and MIDP classes.

Figure 16 presents the software for a J2ME MIDP environment.

15 Within this diagram, the Agent Container is considered to be an OEM Application. The Agent Container uses a number of J2ME MIDP APIs provided by the Jazz Wireless Application Server. These APIs are considered to be OEM Specific APIs and include:

20 a lightweight windowing system based on AWT; and an on-demand record management system that provides support for seamless backup and retrieval of data to and from the Agent Gateway.

The runtime environment for a MIDP Agent Container is 25 web-like in that communication between the container and the Agent Gateway is based on the use of HTTP.

Figure 17 illustrates the runtime environment. The Agent Container is both a client and a server application:

30 As a *client*, the container sends messages from the container to the gateway. The most common message is a Conversation. Messages that are a description of a conversation between the user and a creature utilise the *Conversation Protocol*.

35 As a *server*, it accepts messages from the gateway. Messages can be:

visiting agents that are sent to the container to be presented to the user;

- 49 -

collectibles that are broadcast to the container for redemption by the user.

The J2ME MIDP Agent Container is really a simple browser that allows an agent to be visually presented
5 (rendered) on a small wireless, graphical (and most likely colour) display.

Figure 18 illustrates the container running on the Sun J2ME MIDP Simulator:

The container has 5 basic elements:

- 10 The Agent View
- The Talking Bubble
- Supporting Agent Functions
- The Waiting Room
- The Secure Inventory

15 The Agent View is the main view in the browser. It is the component where the creature is animated in accordance.

The *Talking Bubble* is attached to the Agent View. When the creature talks with their user and visa versa,
20 the text of the conversation is displayed in this bubble.

The attributes of the creature can be changed using the *Agent Functions*.

When other agents visit a user, they arrive in the *Waiting Room*. The user can view the waiting room and see
25 select to converse with a visiting agent waiting there. When a user activates a visiting agent, it appears in the Agent View and the user can converse with that agent using the *Talking Bubble*.

The concept of a Secure Agent Container adds a new
30 dimension to the Agent Services that an operator can offer their subscribers.

A Secure Agent Container is one in which transient agents can be "securely" stored and processed (eg as a payment given that the transient agent is a voucher of
35 some form):

The Secure Inventory provides the functionality required to realise the concept of the Secure Agent

- 50 -

Container. The Secure Inventory:

ensures that a copy of all transient agents being held on the wireless device are backed up to the Agent Gateway. This alleviates the issue of a consumer "losing their collectibles" when they lose their handset. When a new handset is obtained and the agent container reloaded, the state of the container (and the collectibles) is retrieved from the gateway;

can utilise any network connection type from the handset to a connection point to redeem collectible, or transfer them from one container to another. The different connection types include:

the primary wireless connection protocol - GPRS/3G etc;

low power, localised network connection types - BLUETOOTH, IR etc;

can retrieve and store collectibles broadcast from an Agent Broadcaster to the handset via the Agent Gateway.

The MIDP Agent Container provides location and time information to the Gateway in the same manner as the Java Card SIM Agent Container.

Loyalty Points

Unlike the Java Card SIM container, a local copy of the Loyalty Point total for a user and their creature is not maintained in the MIDP Agent Container. The total is always obtained from the Agent Gateway. This is possible because the underlying transport for the connectivity between the MIDP container and the gateway is the more time responsive HTTP, not SMS.

The Agent Container makes Loyalty Points available to the user as Collectibles within the Secure Inventory. This means that the user/creature can redeem the points at any stage using the facilities of the Secure Container.

The Agent Broadcaster

The Agent Broadcaster and Secure Agent Container.

Substitute Sheet
(Rule 26) RO/AU

- 51 -

Together, these products promote the development of secure, personal transactions using Transient Agents.

The Agent Broadcaster is a server technology that can be licensed to content providers to allow them to
5 broadcast transient agents over the operator network via the Agent Gateway to J2ME enabled mobile devices (running the J2ME Secure Agent Container). For example, Ticket Master, McDonalds, Retail Stores etc may use an Agent Broadcaster to broadcast promotions or redeemable vouchers
10 as "transient" agents to consumers.

Using the Secure Agent Container, consumers can then redeem/manipulate the received vouchers using their mobile device, and possibly a Bluetooth connection between the mobile device and a redemption point (eg point of sale
15 terminal).

This technology proactively demonstrates how Operators can position themselves as keepers of "secure payment transactions" over the wireless network through the deployment of an Agent Container to their consumers.
20

To realise this product concept, the following technologies are required:

J2ME enabled mobile phones; and

BLUETOOTH enabled mobile phones (for localised redemption of vouchers).

25 Java Card SIM for cryptography operations within the J2ME Secure Agent Container, and/or STIP to support the notion of a secure payment mechanism on a J2ME device. (Talking Point is exploring the possibility of working together with Cardsoft to develop a Secure Agent Container
30 that will run on their J2ME STIP implementation).

It will be appreciated by persons skilled in the art that numerous variations and/or modifications may be made
35 to the invention as shown in the specific embodiments without departing from the spirit or scope of the invention as broadly described. The present embodiments are,

Substitute Sheet
(Rule 26) RO/AU

therefore, to be considered in all respects as illustrative and not restrictive:

- 53 -

THE CLAIMS DEFINING THE INVENTION ARE AS FOLLOWS:

1. A system for providing an intelligent agent which is arranged to carry out tasks in response to
5 instructions from a user, the tasks being actioned in a network environment, the system comprising agent interface means arranged to provide an agent interface at a user terminal for interaction with a user, and agent implementation means for implementing
10 tasks instructed to the agent interface by the user, the user terminal comprising a mobile communications device utilising a mobile communications network for communications.
- 15 2. A system in accordance with claim 1, further comprising attribute implementation means arranged to implement the provision of attributes to the intelligent agent, wherein the attributes are arranged to determine the functionality of the
20 intelligent agent in carrying out tasks.
3. A system in accordance with claim 1 or claim 2, the system including user mood determination means arranged to determine the mood of the user and effect
25 the operation of the intelligent agent accordingly.
4. A system for providing an intelligent agent which is arranged to carry out tasks in response to
30 instructions from a user, the tasks being actioned in a network environment, the system comprising agent interface means arranged to provide an agent interface at a user terminal for interaction with the

Substitute Sheet
(Rule 26) RO/AU

- 54 -

user, and agent implementation means for implementing tasks instructed to the agent interface by the user.

5. A system in accordance with claim 4, wherein the user terminal is a mobile communications device.
6. A system in accordance with claim 5 wherein the mobile communications device is a small computing device.
7. A system in accordance with claim 6, wherein the small computing device is a mobile telephone.
8. A system in accordance with any one of claims 4 to 7, wherein network communications with the user terminal are by wireless.
9. A system in accordance with claim 8, wherein the network communications with the user terminal are by way of a mobile telephone network.
10. A system in accordance with any one of claims 4 to 9, wherein security means are provided on the user terminal, to prevent unauthorised persons from utilising the intelligent agent.
11. A system in accordance with any one of claims 4 to 10, wherein the agent implementations means enables tasks such as taking part in competitions or obtaining information requested by a user, or ordering tickets to entertainment venues, or electronic commerce transactions on behalf of users.

Substitute Sheet
(Rule 26) RO/AU

- 55 -

12. A system in accordance with any one of claims 4 to 11, wherein the agent implementation means enables a task to be carried out over a close proximity network interacting with a system located in, for example, retail locations.
13. A system in accordance with any one of claims 4 to 12, wherein there are a plurality of intelligent agents each of which is associated with an identified user.
14. A system in accordance with claim 13, further including agent interaction means, arranged to enable interaction between intelligent agents of users.
15. A system in accordance with claim 14, wherein the agent interaction means enables interaction between agents such as the giving and receiving of messages.
16. A system in accordance with any one of claims 4 to 15, further comprising attribute implementation means, arranged to implement the provision of attributes to the intelligent agent.
17. A system in accordance with claim 16, wherein the attributes are arranged to determine the functionality of the intelligent agent in carrying out tasks.
18. A system in accordance with claims 16 or 17, wherein the attribute implementation is arranged to affect changes to the attributes of the intelligent agent in accordance with predetermined criteria.

Substitute Sheet
(Rule 26) RO/AU

19. A system in accordance with claim 18, wherein the predetermined criteria includes operation of the intelligent agent in carrying out tasks.
- 5
20. A system in accordance with any one of the claims 16 to 19, wherein the agent interface is arranged to enable the user to determine the attributes to be provided to the intelligent agent via the attribute implementation means.
- 10
21. A system in accordance with any one of the claims 16 to 20, wherein the agent interface is arranged to enable the user to affect changes in the attributes of the intelligent agent via the attribute implementation means.
- 15
22. A system in accordance with any one of claims 16 to 21 when read back onto claim 14 or 15, wherein interaction between intelligent agents depends on the respective attributes of the intelligent agents.
- 20
23. A system in accordance with any one of claims 4 to 22, the system including user mood determination means arranged to determine the mood of the user and affect the operation of the intelligent agent accordingly.
- 25
24. A system in accordance with claim 23, the mood determination means being arranged to determine the mood of the user from information input to the user terminal by the user.
- 30

- 57 -

25. A system in accordance with claim 23 or 24, the mood determination means being arranged to determine the mood of the user from the manner of the interaction of the user with the user terminal.
- 5
26. A system in accordance with any one of claims 4 to 25 including push content provisions means for providing push content to the user terminal in association with operation of the intelligent agent.
- 10
27. A system in accordance with claim 26, wherein the push content contains information chosen according to operation of the intelligent agent by the user.
- 15
28. A system in accordance with claim 27, wherein the push content information is chosen according to the history of the operation of the intelligent agent by the user.
- 20
29. A system in accordance with any one of claims 4 to 28 including means arranged to determine location of user terminals associated with intelligent agents.
- 25
30. A system in accordance with claim 29, wherein the agent implementation means is arranged to affect operation of the intelligent agent in accordance with the physical location of the user terminal.
- 30
31. A system in accordance with any one of claims 4 to 30, wherein the agent interface is arranged to represent the intelligent agent at the user terminal as a characterisation.

Substitute Sheet
(Rule 26) RO/AU

- 58 -

32. A method of enabling a user of a user terminal in a network environment to carry out tasks, the tasks being actioned in the network environment, comprising the steps of implementing in the network environment an intelligent agent which is arranged to carry out the tasks instructed by the user via the network terminal.
33. A method in accordance with claim 32, employing the system of any one of the claims 4 to 31.
34. A system in accordance with any one of claims 4 to 31, the system further comprising transient agent interface means implementation means of implementing transient agent.
35. A system in accordance with claim 34, wherein the system is arranged to broadcast transient agent interface means to a plurality of user terminals.
36. A system in accordance with claim 34 or claim 35, the user terminal including an agent container for storing transient agent interface means.
37. A system in accordance with any one of claims 34 to 36, further including transient agent implementation means for implementing tasks instructed to the transient agent.
38. A system in accordance with claim 34 to 38, wherein a transient agent includes a voucher for a product or service.

Substitute Sheet
(Rule 26) RO/AU

- 59 -

39. A system in accordance with any one of claims 4 to
38, the user terminal including means for interacting
with the network environment, a further means for
interacting with a further network environment, the
5 interactive agent being arranged to operate in the
further network environment.

40. A system in accordance with claim 39, wherein the
further network environment is a micro network.
10

41. A system in accordance with any one of claims 4 to
40, the user terminal including a client, and the
agent implementation means being arranged to
interface with a plurality of different types of
15 client.

42. A system in accordance with any one of claims 4 to
40, the user terminal including an agent container
arranged to store an agent interface implementation
20 means for implementing the agent interface.

25 Dated this 1st Day of February, 2000
NEXTGEN PTY LIMITED
By its Patent Attorney
GRIFFITH HACK

Substitute Sheet
(Rule 26) RO/AU

1/12

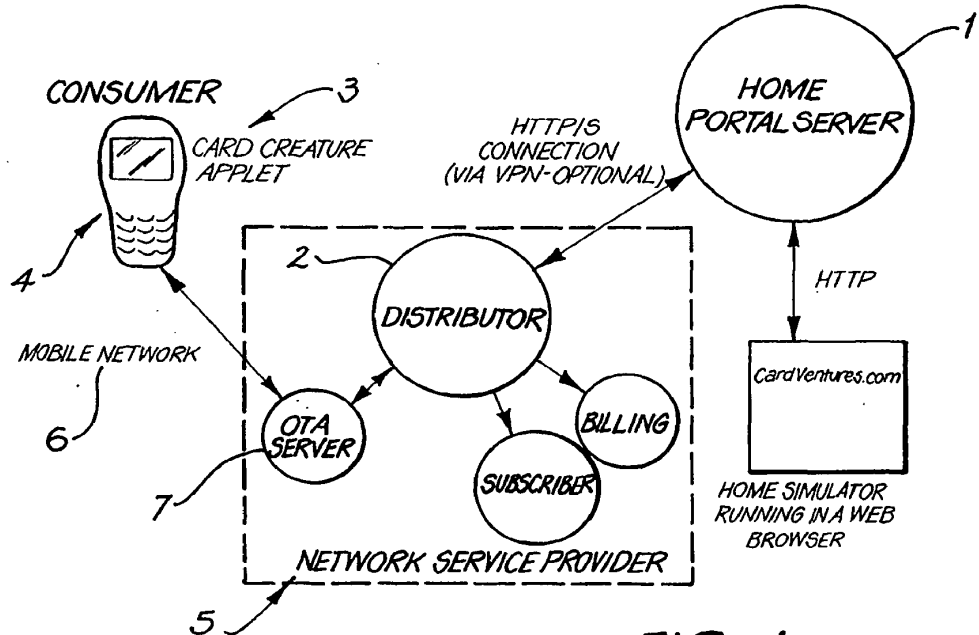

FIG. 1

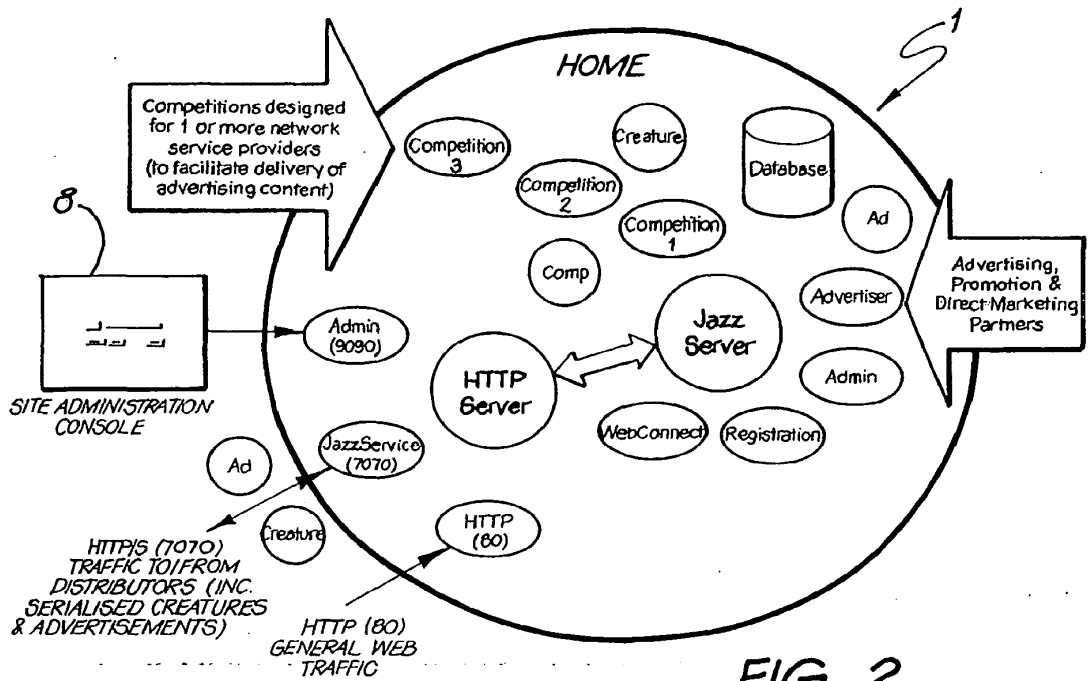
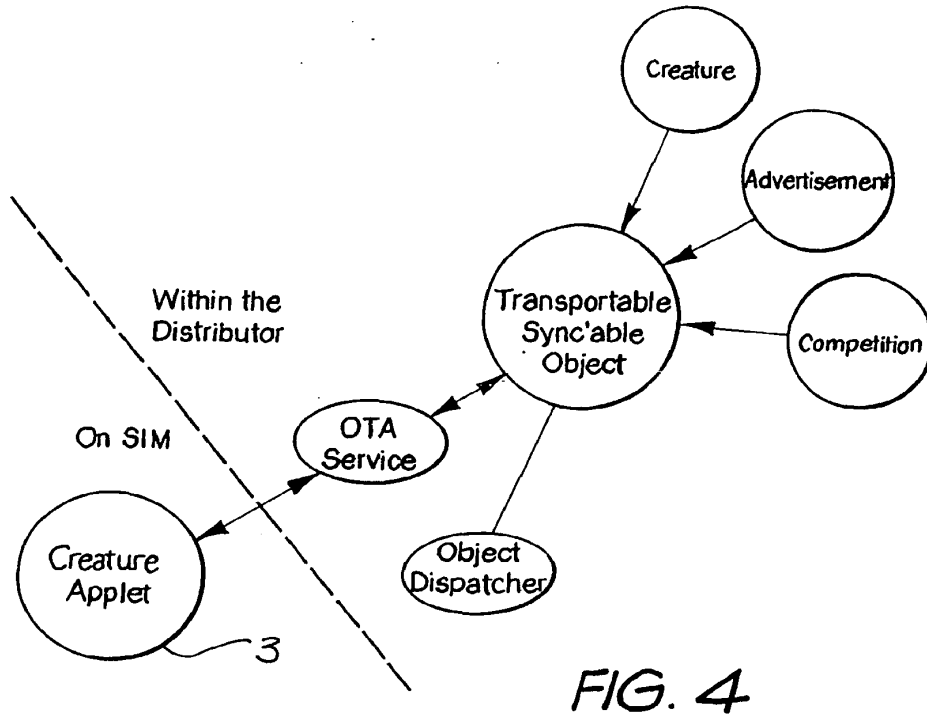
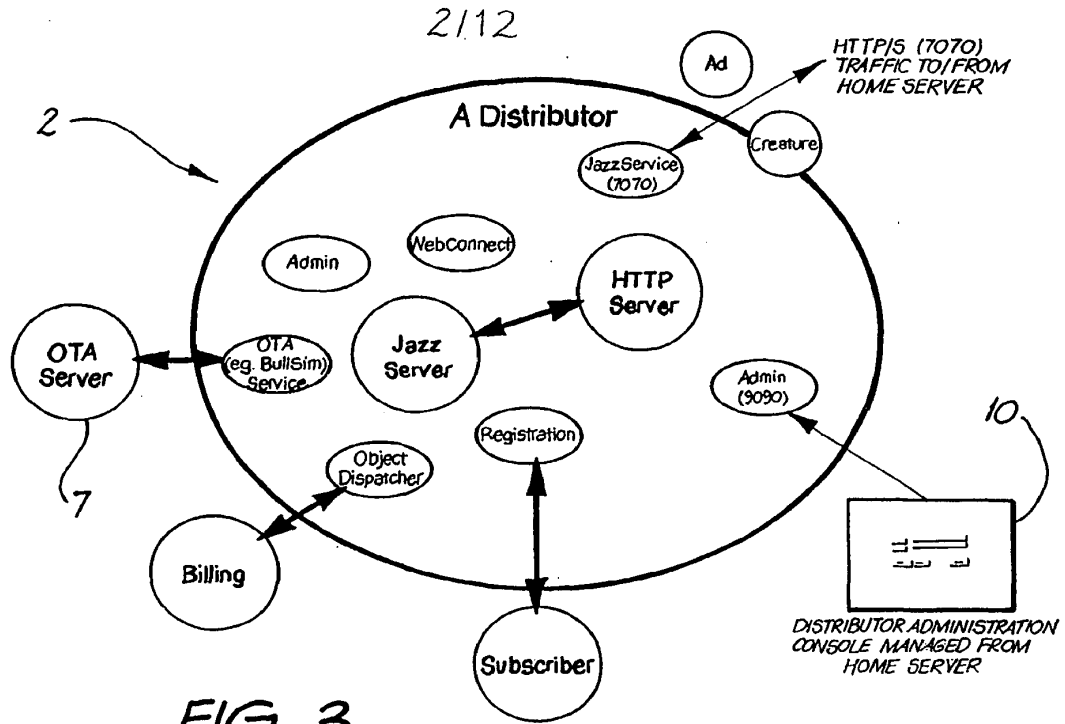

FIG. 2

Substitute Sheet (Rule 26) RO/AU



Substitute Sheet
(Rule 26) RO/AU

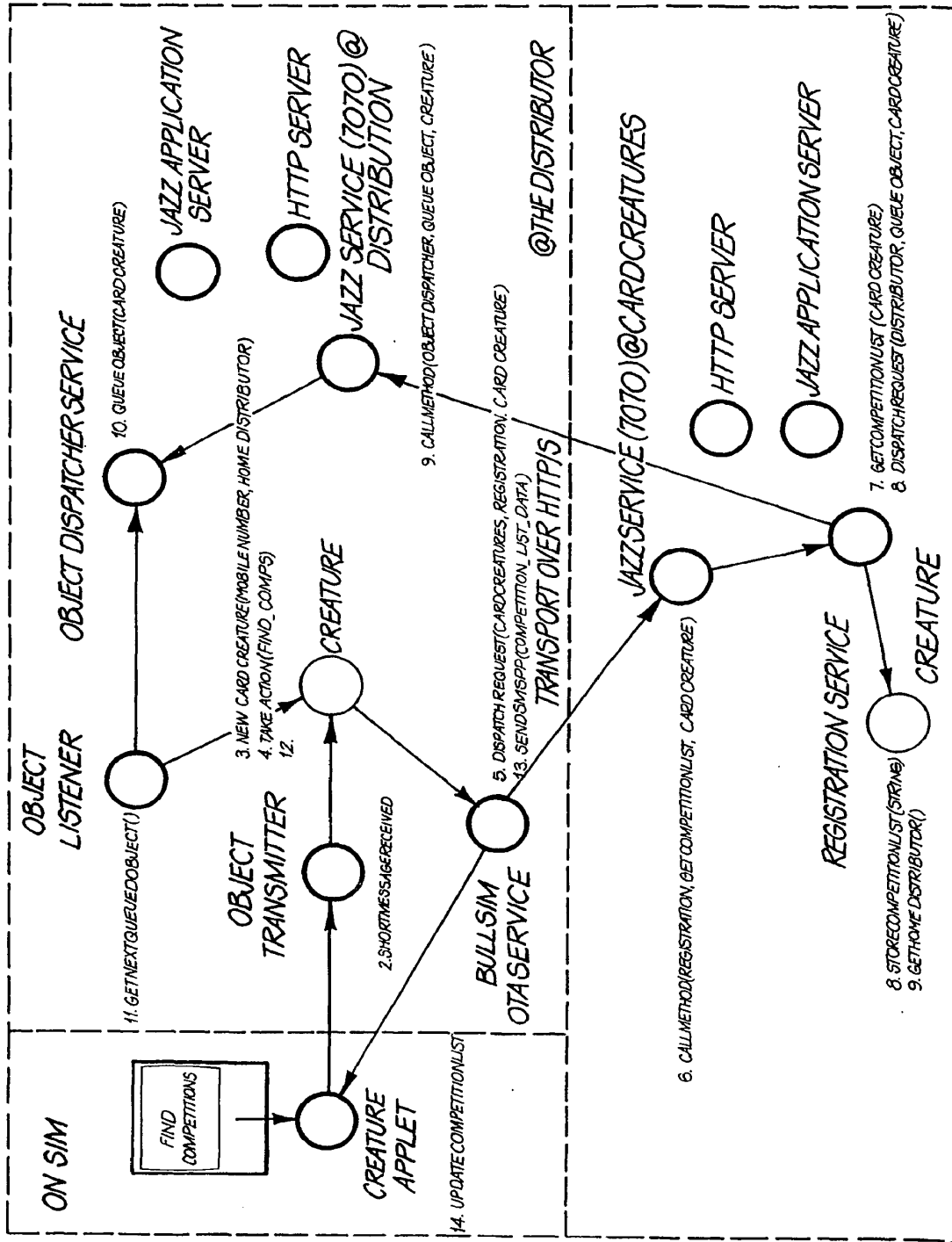

FIG. 5

Substitute Sheet (Rule 26) RO/AU

4/12

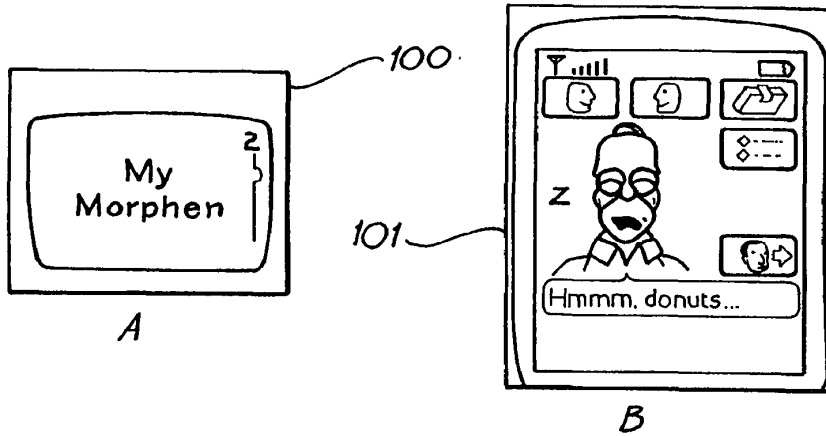

FIG. 6

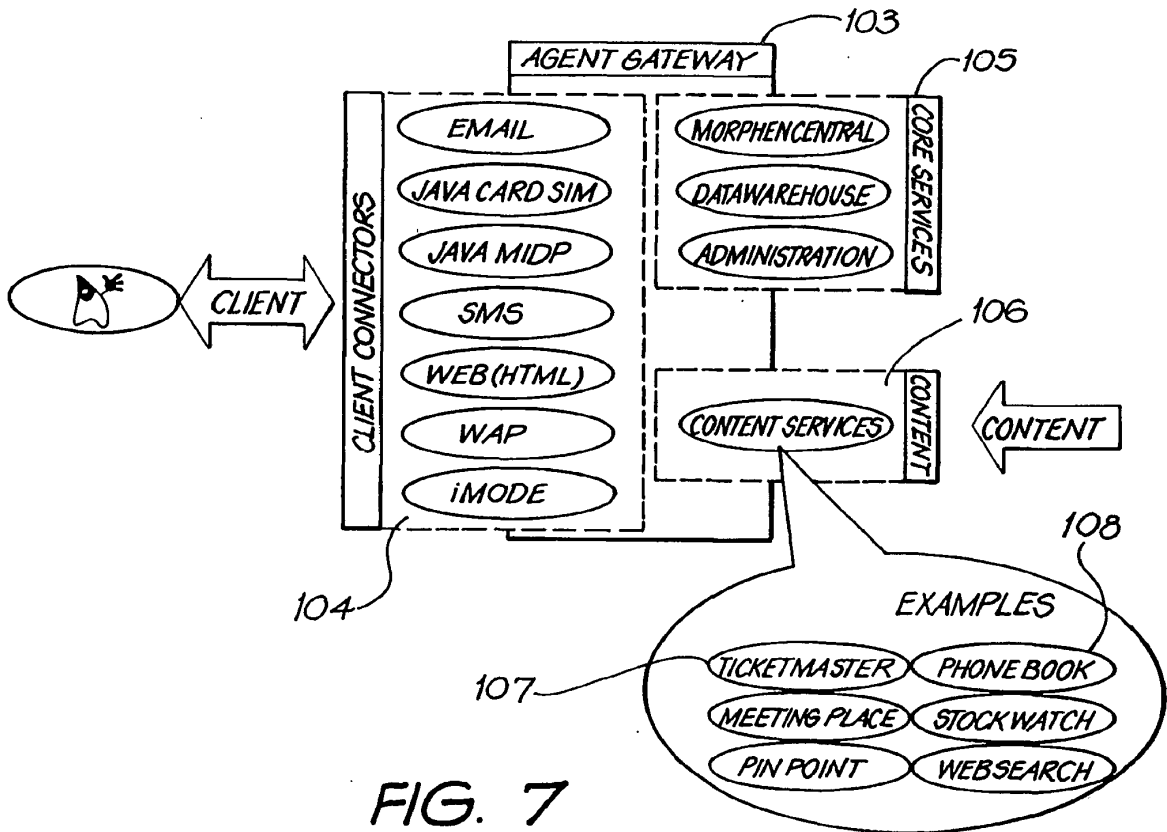

FIG. 7

5/12

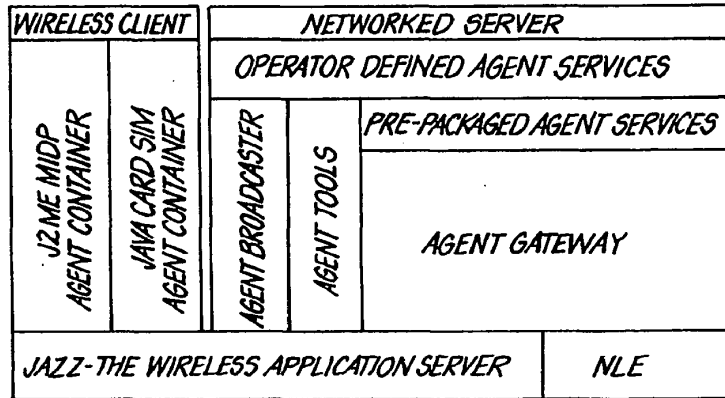

FIG. 8

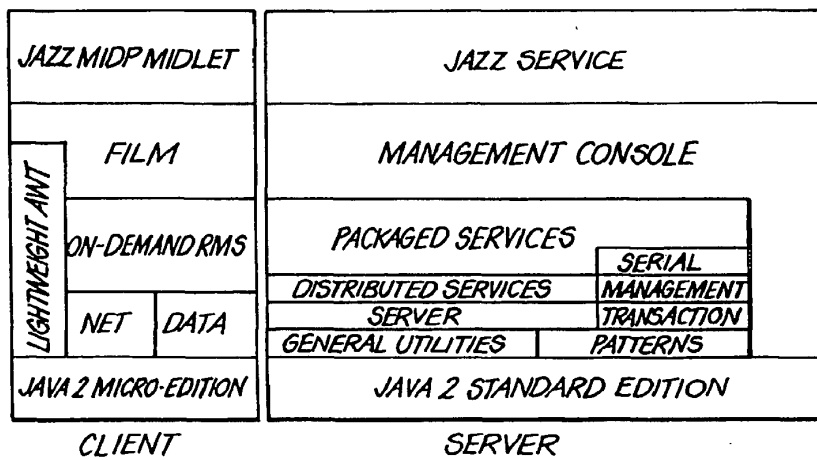

FIG. 9

Substitute Sheet
(Rule 26) RO/AU

6/12

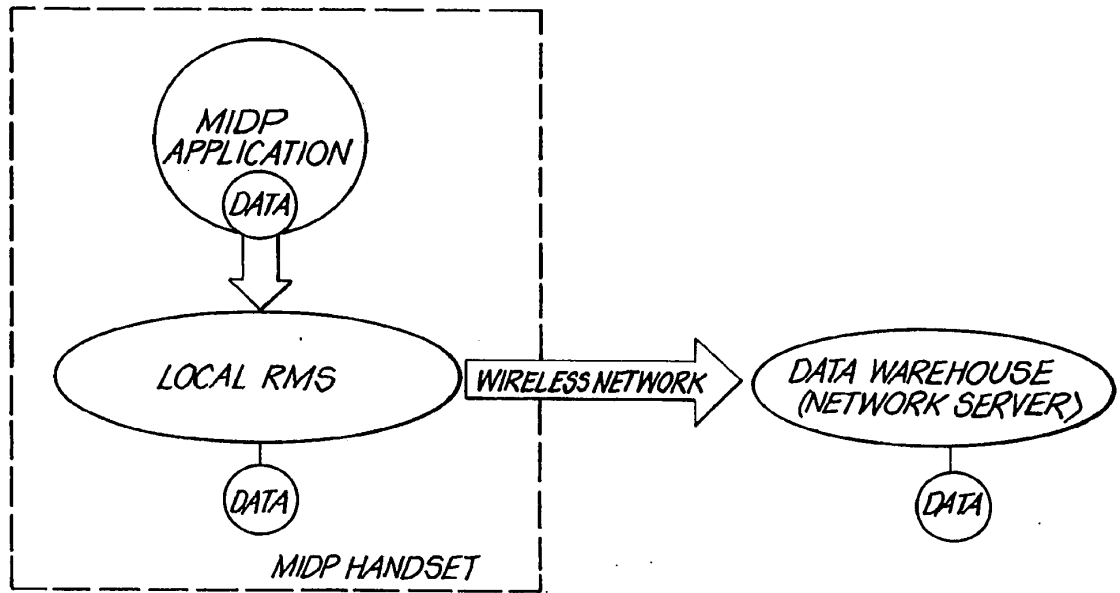

FIG. 10

7/12

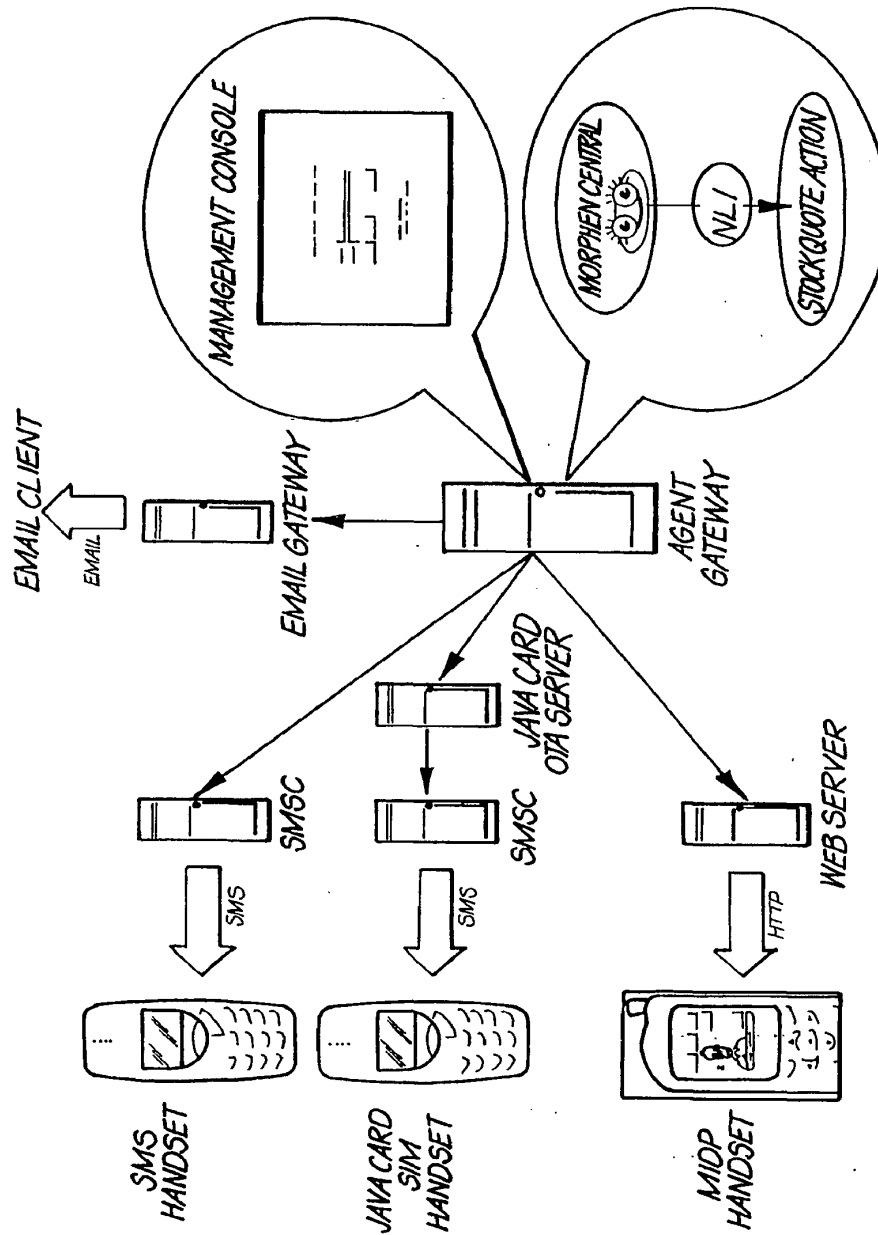

FIG. 11

Substitute Sheet
(Rule 26) RO/AU

8/12

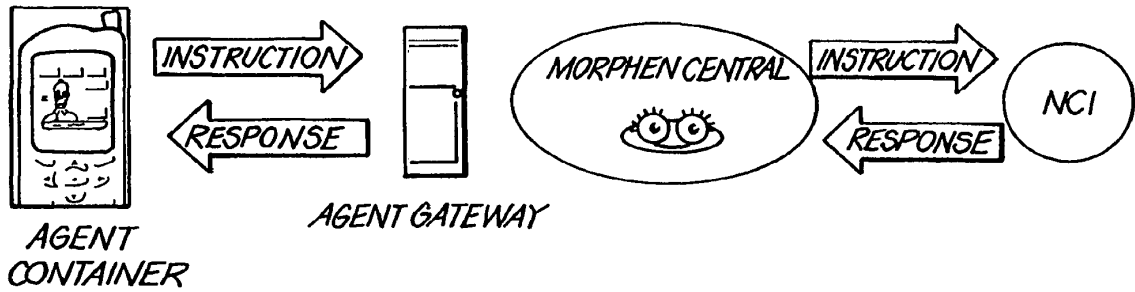

FIG. 12

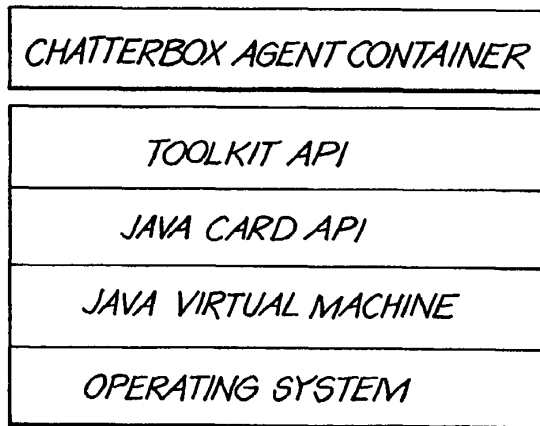

FIG. 13

Substitute Sheet
(Rule 26) RO/AU

9/12

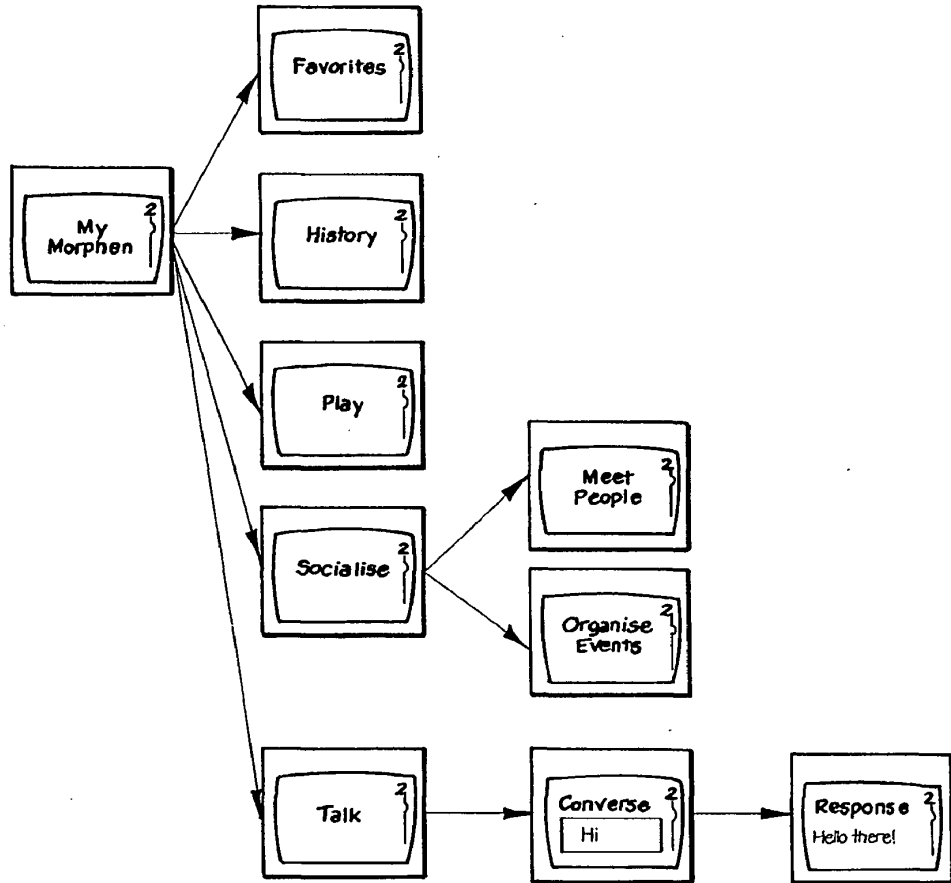

FIG. 14

10/12

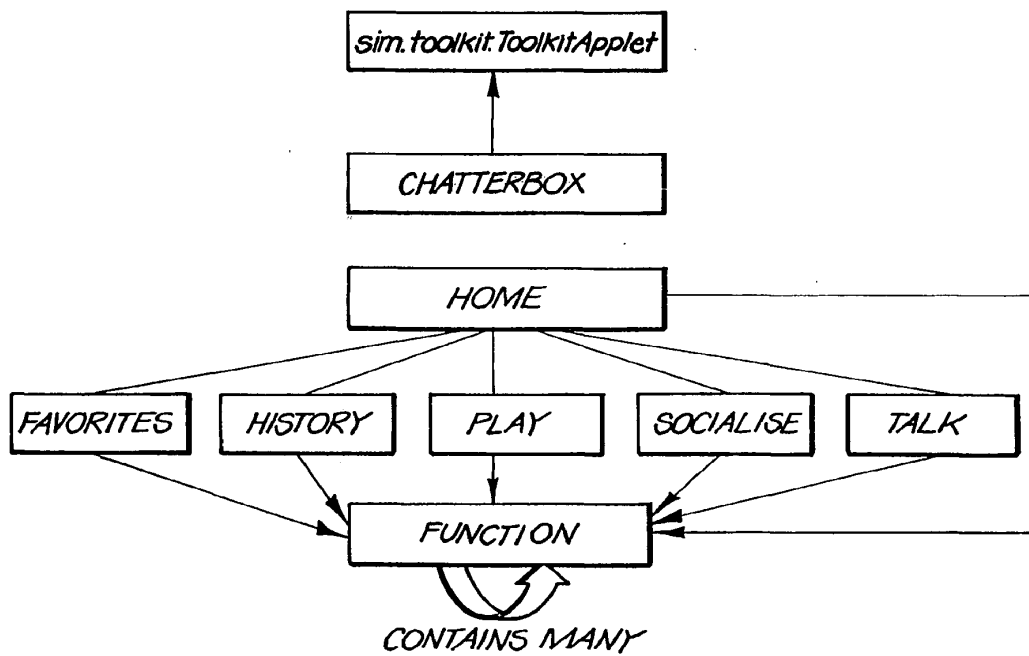

FIG. 15

11/12

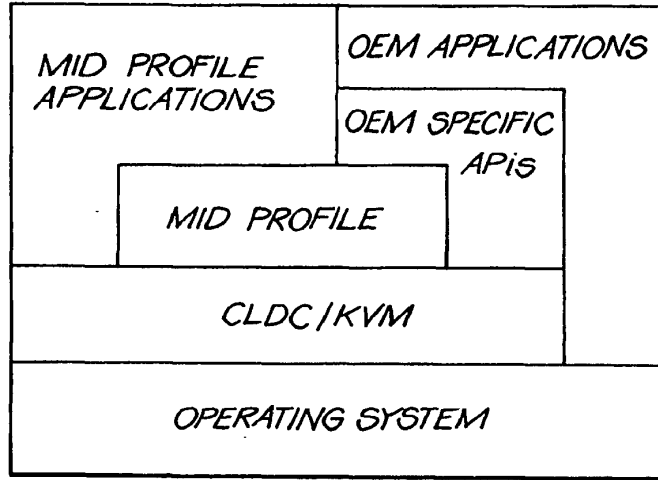

FIG. 16

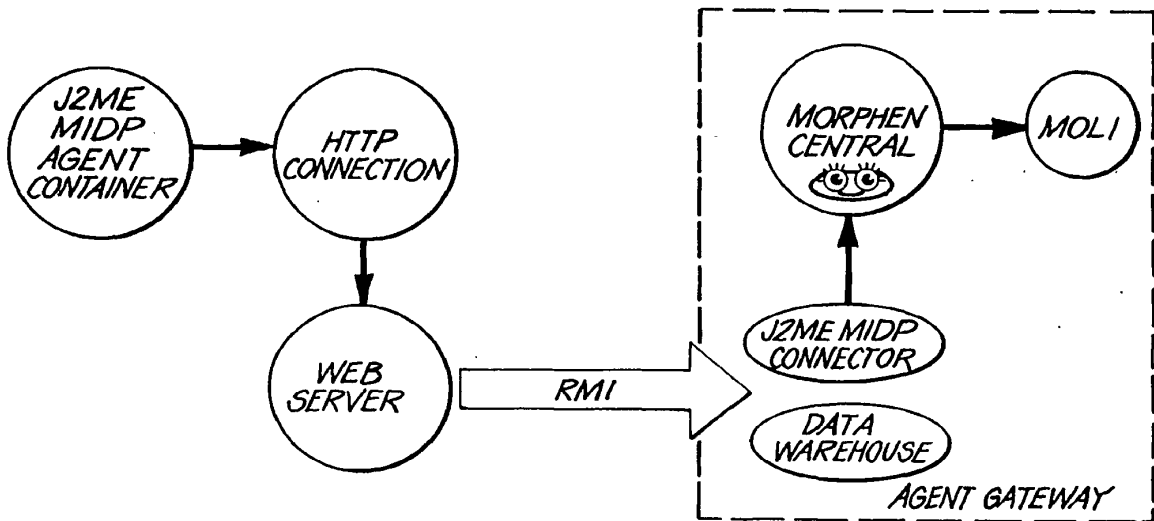

FIG. 17

Substitute Sheet
(Rule 26) RO/AU

12/12

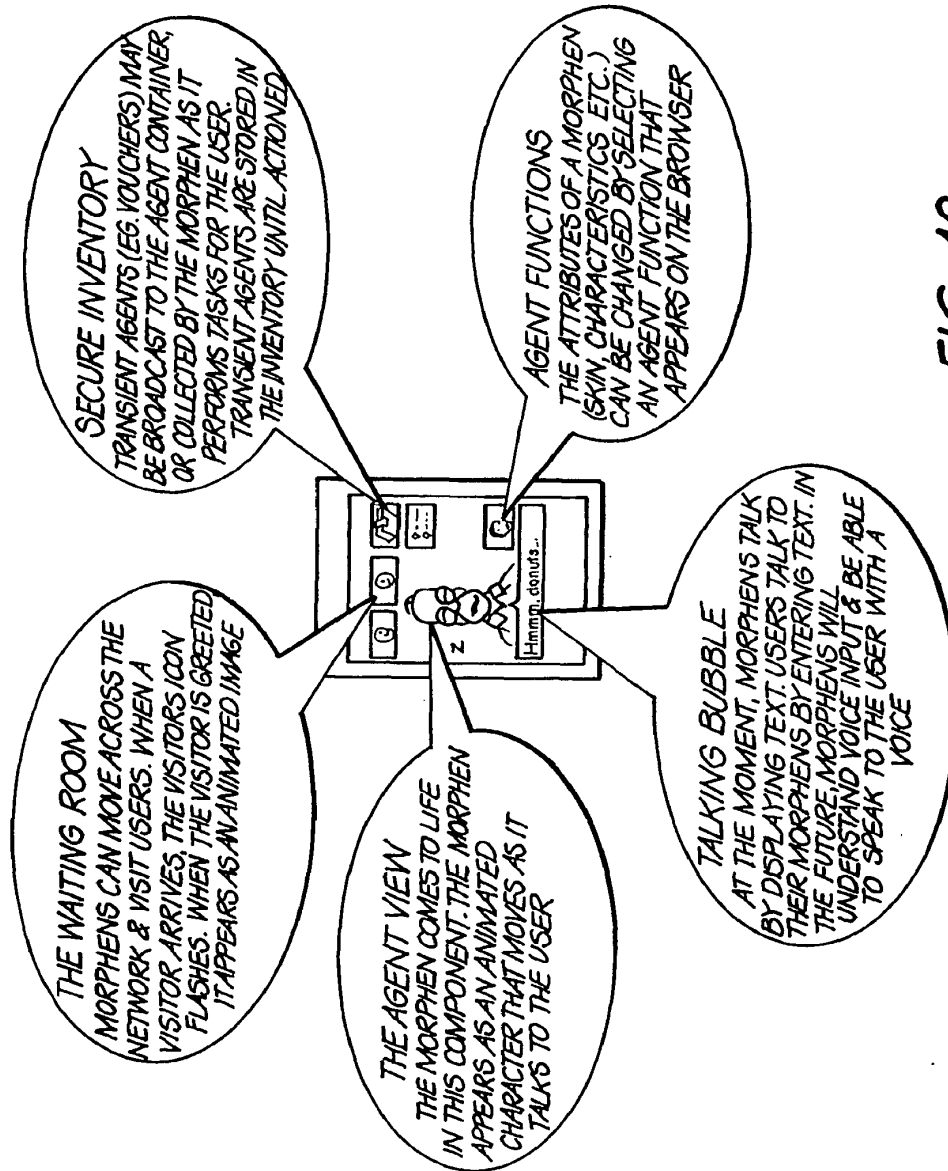

FIG. 18

Substitute Sheet
(Rule 26) RO/AU

INTERNATIONAL SEARCH REPORT

International application No.
PCT/AU 01/00132

A. CLASSIFICATION OF SUBJECT MATTER		
Int Cl ⁷ : G06F 17/30, 13/00		
According to International Patent Classification (IPC) or to both national classification and IPC		
B. FIELDS SEARCHED		
Minimum documentation searched (classification system followed by classification symbols) WHOLE IPC		
Documentation searched other than minimum documentation to the extent that such documents are included in the fields searched WHOLE IPC		
Electronic data base consulted during the international search (name of data base and, where practicable, search terms used) WPAT : (Remote Program, Remote Computing, Intelligent, Interactive, Network, Agent, Task, Terminal, Interface, Mobile Phone, PHS, Cell Phone, PDA)		
C. DOCUMENTS CONSIDERED TO BE RELEVANT		
Category*	Citation of document, with indication, where appropriate, of the relevant passages	Relevant to claim No.
X	US 5761663 A (Lagarde et al.) 2 June 1998 Col. 4 Line 45 - Col. 19 Line 45	1-42
X	WO 98/47250 A2 (INTERNATIONAL BUSINESS MACHINES CORP.) 22 October 1998 Page 5 Line 5 - Page 29 Line 34	1-42
P,X	US 6076099 A (Chen et al.) 13 June 2000 Col. 2 Line 42 - Col. 9 Line 18	1-42
<input checked="" type="checkbox"/>	Further documents are listed in the continuation of Box C	<input checked="" type="checkbox"/> See patent family annex
* "A" "E" "L" "O" "P"	Special categories of cited documents: Document defining the general state of the art which is not considered to be of particular relevance earlier application or patent but published on or after the international filing date document which may throw doubts on priority claim(s) or which is cited to establish the publication date of another citation or other special reason (as specified) document referring to an oral disclosure, use, exhibition or other means document published prior to the international filing date but later than the priority date claimed	"T" later document published after the international filing date or priority date and not in conflict with the application but cited to understand the principle or theory underlying the invention "X" document of particular relevance; the claimed invention cannot be considered novel or cannot be considered to involve an inventive step when the document is taken alone "Y" document of particular relevance; the claimed invention cannot be considered to involve an inventive step when the document is combined with one or more other such documents, such combination being obvious to a person skilled in the art "&" document member of the same patent family
Date of the actual completion of the international search 30 March 2001		Date of mailing of the international search report <i>19 April 2001</i>
Name and mailing address of the ISA/AU AUSTRALIAN PATENT OFFICE PO BOX 200 WODEN ACT 2606 AUSTRALIA E-mail address: pct@ipaustalia.gov.au Facsimile No.: (02) 6285 3929		Authorized officer JUZER KHANBHAI Telephone No.: (02) 6283 2176

INTERNATIONAL SEARCH REPORT

International application No.
PCT/AU 01/00132

C (Continuation). DOCUMENTS CONSIDERED TO BE RELEVANT		
Category*	Citation of document, with indication, where appropriate, of the relevant passages	Relevant to claim No.
P, X	WO 00/54178 A2 (A C PROPERTIES B.V) 14 Septmeber 2000 Page 3 Line 23 - Page 102 Line 18	1-42
P, X	US 6134548 A (Gottsman et al.) 17 October 2000 Col 1 Line 54 - Col. 44 Line 18	1-42
P, X	WO 00/63837 A1 (TEXTWISE, LLC) 26 October 2000 Page 4 Line 9 - Page 23 Line 18	1-42

INTERNATIONAL SEARCH REPORT
Information on patent family members

International application No.
PCT/AU 01/00132

This Annex lists the known "A" publication level patent family members relating to the patent documents cited in the above-mentioned international search report. The Australian Patent Office is in no way liable for these particulars which are merely given for the purpose of information.

Patent Document Cited in Search Report		Patent Family Member					
US	5761663	EP	19961211	EP	19961211	EP	19961211
		JP	19970128	JP	19970128	JP	19970128
		US	19980120	US	19980120	US	19980120
		US	19980602	US	19980602	US	19980602
		BR	19981006	BR	19981006	BR	19981006
		CA	19961208	CA	19961208	CA	19961208
		CN	19970122	CN	19970122	CN	19970122
		EP	19961211	EP	19961211	EP	19961211
		JP	19970214	JP	19970214	JP	19970214
		US	19980811	US	19980811	US	19980811
		EP	19961211	EP	19961211	EP	19961211
		JP	19970502	JP	19970502	JP	19970502
		US	19971223	US	19971223	US	19971223
		US	19991026	US	19991026	US	19991026
		US	20000725	US	20000725	US	20000725
		CA	19961208	US	19961208	US	19961208
		CN	19961218	CN	19961218	CN	19961218
		EP	19961211	EP	19961211	EP	19961211
		JP	19970128	JP	19970128	JP	19970128
		US	19980224	US	19980224	JP	19980224
		EP	19961211	EP	19961211	EP	19961211
		JP	19970128	JP	19970128	JP	19970128
		US	19980120	US	19980120	US	19980120
		US	19980602	US	19980602	US	19980602
		BR	19981006	BR	19981006	BR	19981006
		CA	19961208	CA	19961208	CA	19961208
		CN	19970122	CN	19970122	CN	19970122
		EP	19961211	EP	19961211	EP	19961211
		JP	19970214	JP	19970214	JP	19970214
		US	19980811	US	19980811	US	19980811

CONTINUED

Patent Document Cited in Search Report		Patent Family Member			
	EP 19961211	EP 19961211	EP 19961211	EP 19961211	EP 19961211
	JP 19970502	JP 19970502	JP 19970502	JP 19970502	JP 19970502
	US 19971223	US 19971223	US 19971223	US 19971223	US 19971223
	US 19991026	US 19991026	US 19991026	US 19991026	US 19991026
	US 20000725	US 20000725	US 20000725	US 20000725	US 20000725
	CA 19961208	CA 19961208	CA 19961208	CA 19961208	CA 19961208
	CN 19961218	CN 19961218	CN 19961218	CN 19961218	CN 19961218
	EP 19961211	EP 19961211	EP 19961211	EP 19961211	EP 19961211
	JP 19970128	JP 19970128	JP 19970128	JP 19970128	JP 19970128
	US 19980224	US 19980224	US 19980224	US 19980224	US 19980224
	US 19991026	US 19991026	US 19991026	US 19991026	US 19991026
	US 20000725	US 20000725	US 20000725	US 20000725	US 20000725
WO	98/47250				
US	6076099 A	US	20000613	US	20000613
US	6076099 A	US	20000613	US	20000613
WO	00/54178				
US	6134548 A	AU	20000529	AU	20000529
		US	20001017	AU	20001017
		WO	20000518	WO	20000518
		AU	200015234	AU	200015234
		US	20001017	US	20001017
		WO	20000518	WO	20000518
WO	00/63837				
END OF ANNEX					

(12) INTERNATIONAL APPLICATION PUBLISHED UNDER THE PATENT COOPERATION TREATY (PCT)

(19) World Intellectual Property Organization
International Bureau



(43) International Publication Date
22 November 2001 (22.11.2001)

PCT

(10) International Publication Number
WO 01/89150 A2

(51) International Patent Classification⁷: H04L 12/18
(21) International Application Number: PCT/US01/16156
(22) International Filing Date: 18 May 2001 (18.05.2001)
(25) Filing Language: English
(26) Publication Language: English
(30) Priority Data:
09/572,853 18 May 2000 (18.05.2000) US
(71) Applicant: RELIACAST, INC. [US/US]; Suite #1, 397 Herndon Parkway, Herndon, VA 20170 (US).

(81) Designated States (national): AE, AG, AL, AM, AT, AU, AZ, BA, BB, BG, BR, BY, BZ, CA, CH, CN, CR, CU, CZ, DE, DK, DM, DZ, EE, ES, FI, GB, GD, GE, GH, GM, HR, HU, ID, IL, IN, IS, JP, KE, KG, KP, KR, KZ, LC, LK, LR, LS, LT, LU, LV, MA, MD, MG, MK, MN, MW, MX, MZ, NO, NZ, PL, PT, RO, RU, SD, SE, SG, SI, SK, SL, TJ, TM, TR, TT, TZ, UA, UG, UZ, VN, YU, ZA, ZW.

(72) Inventors: MCNABB, James; Apartment 402, 1739 Port Place, Reston, VA 20194 (US). BATTLE, Ben; 13606 Old Chatwood Place, Chantilly, VA 20151-3369 (US).
(74) Agents: TALBOT, Scott, C. et al.; Cooley Godward LLP, One Freedom Square, 11951 Freedom Drive, Reston, VA 20191-5601 (US).

(84) Designated States (regional): ARIPO patent (GH, GM, KE, LS, MW, MZ, SD, SL, SZ, TZ, UG, ZW), Eurasian patent (AM, AZ, BY, KG, KZ, MD, RU, TJ, TM), European patent (AT, BE, CH, CY, DE, DK, ES, FI, FR, GB, GR, IE, IT, LU, MC, NL, PT, SE, TR), OAPI patent (BF, BJ, CF, CG, CI, CM, GA, GN, GW, ML, MR, NE, SN, TD, TG).

Published:
— without international search report and to be republished upon receipt of that report

For two-letter codes and other abbreviations, refer to the "Guidance Notes on Codes and Abbreviations" appearing at the beginning of each regular issue of the PCT Gazette.

(54) Title: SYSTEM AND METHOD FOR MULTICASTING DATA

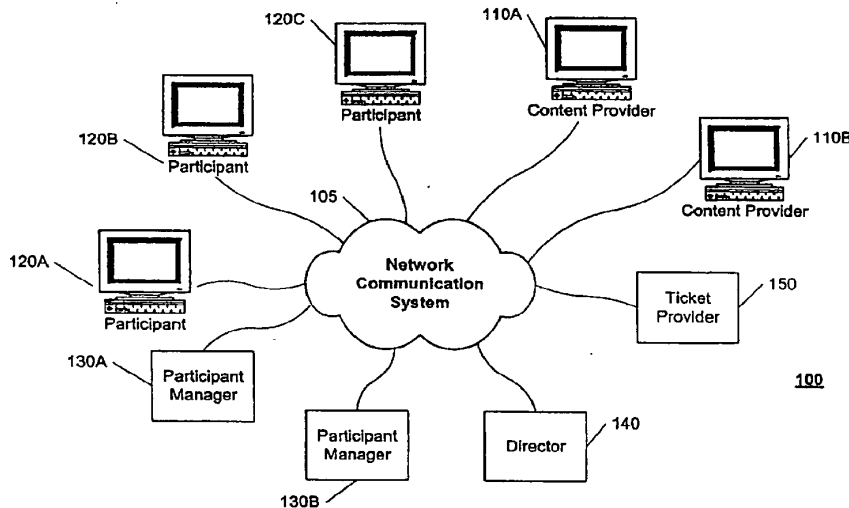

(57) Abstract: A system and method for multicasting data over a network includes a director, a hierarchy of participant managers, and a turnstile installed at each participant to which the data is multicasted. Content providers provide information associated with an event to the director. The director oversees the delivery of the event to a participant. In particular, the director allocates and provides a ticket to the event to the participant. The participant acquires the ticket, either directly or indirectly from the director. When the participant attempts to access the event, the locally installed turnstile authenticates the ticket thereby gating access to the event. The turnstile also provides delivery statistics associated with the delivery of the event to the director via the hierarchy of participant managers.

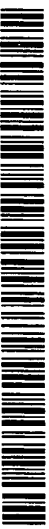

WO 01/89150 A2

SYSTEM AND METHOD FOR MULTICASTING DATA

Background

Field of the Invention

The present invention relates generally to network communications systems and more particularly to managing data multicasting over a network where
5 recipients of that data can be authorized, authenticated, and billed for receiving that data.

Discussion of the Related Art

Today's user of a network communication system is demanding that large amounts of content (*i.e.* data, voice, images, video, etc.) be delivered to their
10 network receiving device (*e.g.*, computer, set-top, PDA, cellular phone, etc.) in real-time. As network communications systems, particularly the Internet, become a ubiquitous communication link among users worldwide, more applications are looking to this link to deliver content to multiple users simultaneously in the form of a network broadcast. In the network broadcast, multiple users receive similar or
15 identical content from a single source virtually simultaneously.

One conventional mechanism for delivering content over a network communication system is referred to as a unicast. In unicasting, a source of the content sends the content to each of the users or "recipients" of the content within the network communication system. This is referred to as a "one to one" delivery
20 of content. Unicasting to N recipients involves sending N copies of the content

over the network communication system, one copy to each recipient. For large numbers of recipients, these multiple copies have a deleterious effect on the performance of the network communication system, particularly for content requiring a high amount of bandwidth for delivery (e.g., video streams).

5 Another mechanism for delivering content over the network communication system is to simply broadcast the content to every user on the network communication system regardless of whether the user desires to receive the content or not. This is referred to as a “one to all” delivery of content. With broadcasting, one copy of the content, addressed to every user on the network, is
10 transmitted over the network communication system. While broadcasting reduces the amount of the network bandwidth consumed by the delivery of the content, not all users desire or should receive the content. Furthermore, the source of the content has no mechanism for determining which of the recipients received the content.

15 Another mechanism for delivering content over the network communication system is referred to as a multicast. In multicasting, the source of the content sends one copy of the content addressed to only those recipients who should receive the content. This is referred to as a “one to many” delivery of content. With this form of delivery, the content is replicated at key points in the
20 network communication system so that each recipient receives the content quickly and efficiently without the problems associated with other forms of delivery.

However, conventional delivery of content via multicast still has many problems that heretofore have hindered its adoption as a content delivery standard. One problem associated with multicasting not found with unicasting is that the originator of the content does not know which, if any, of the recipients actually
5 received the content. In contrast, with unicasts, the originator can measure network bandwidth and determine the recipients of the content. However, with unicasts, the number of recipients is bound by the resources available to support the replication of each content stream.

Another problem with multicasting is that the originator of the multicast
10 content is unable to measure the amount and quality of the content delivered to any particular recipient. Originators that bill recipients based on bandwidth usage are reluctant to provide a service for which they cannot effectively measure that usage. Furthermore, in network communication systems employing unicasts, there is a direct relationship between the number of servers in the system and the number of
15 recipients able to be serviced by the system. Thus, billing for those services is relatively straightforward. This same relationship is not available in a network communication system employing multicasts.

What is needed is an improved system and method for multicasting content in a network communication system.

20 ***Summary of the Invention***

The present invention is directed toward a system and method for multicasting data in a network communication system. In particular, the present

invention provides a system and method for managing, measuring, and controlling how information is delivered across a multicast-enabled network communication system (*i.e.*, “multicast environment”). The present invention is described in terms of a stadium analogy where participants receive an “event,” or the information, from a “stadium.” Prior to entering the stadium, participants present a “ticket” at a “turnstile.” The turnstile prevents those participants without a proper ticket from entering the event. The turnstile also provides information via a hierarchy of participant managers to the “director” of the event regarding when the participant entered the event, when the participant exited the event, and/or information regarding the delivery of the event to the participant. The hierarchy of participant managers aggregates this information thereby providing an indication of the stadium’s “use” to the director. This aggregated information may be provided to an event sponsor (*i.e.*, a content provider) for purposes of billing, advertising, and/or determining levels of participation in the event and among events.

One feature of the present invention is that the hierarchy of participant managers is self-organizing and self-healing. Each of the participant managers automatically locates its position in the hierarchy based on a predetermined level. The participant manager multicasts its level to other participant managers, some of which respond and identify their own level. Based on the responses; the participant manager determines to which of the other participant managers it should be attached. If, at any point, one of the participant managers fails, participant managers attached beneath the failing participant manager are able to

relocate themselves within the hierarchy to prevent "blackouts" among particular participants.

Another feature of the present invention is that the participant managers preferably organize themselves on a geographical basis with the lowest level participant managers attached to participants in close physical proximity thereto. Higher level participant managers are similarly attached to the lower level participant managers. In this manner, each subsequently higher level of participant manager represents a greater number of participants in a larger geographic area until the highest level of participant manager represents all the participants of the event. This feature allows the director and/or the content providers to determine the geographic areas of the participants participating in a particular event. The enables the director to properly allocate resources among the geographic areas for future events. This also provides opportunities for targeting advertisements to the participants on a geographic basis.

Still another feature of the present invention collects demographic information associated with the participant in exchange the ticket. Preferably, this demographic information is incorporated into the ticket so that during the event, the director and/or the content provider can identify and classify any of the participants or groups of participants receiving in the event. The demographic information also provides opportunities for targeting advertisements to the participants on a demographic basis.

Yet still another feature of the present invention presents statistics associated with the delivery of the event to participants in a tree structure in a graphic user interface. The tree structure includes the director at the root, various levels of participant managers forming the branches, and participants at the leaves.

5 Each level of participant managers corresponds to a level indicator in the tree structure. Each level indicator identifies the participant manager and provides information about the participant managers or participant connected beneath it in the tree structure. Preferably, this information represents aggregate delivery statistics pertaining to all of the participants connected beneath it in the tree

10 structure. A user is able to navigate the tree structure and “drill down” to particular levels to access these aggregate delivery statistics associated with a particular participant manager or the delivery statistics and/or demographic information pertaining to an individual participant.

These and other features and advantages of the present invention will

15 become apparent from the following drawings and description.

Brief Description of the Drawings

The present invention is described with reference to the accompanying drawings. In the drawings, like reference numbers indicate identical or functionally similar elements. Additionally, the left-most digit(s) of a reference

20 number identifies the drawing in which the reference number first appears.

FIG. 1 illustrates a multicast environment according to the present invention.

FIG. 2 illustrates a stadium analogy useful for describing the present invention.

FIG. 3 illustrates an exemplary hierarchy of participant managers.

FIG. 4 illustrates a director according to a preferred embodiment of the
5 present invention.

FIG. 5 illustrates a graphical user interface for monitoring delivery of an event.

FIG. 6 illustrates an operation of a participant attempting to access an event according to one embodiment of the present invention.

10 FIG. 7 illustrates a stadium according to one embodiment of the present invention.

FIG. 8 illustrates a relationship among participants, participant managers, and content providers.

15 FIG. 9 illustrates a cast transaction according to one embodiment of the present invention.

FIG. 10 illustrates an operation of an autodiscovery algorithm from the perspective of a new participant manager according to a preferred embodiment of the present invention.

20 FIG. 11 illustrates an operation of the present invention from a perspective of a participant.

FIG. 12 illustrates an operation of the present invention from a perspective of a turnstile.

FIG. 13 illustrates an operation of the present invention from a perspective of participant manager.

5 FIG. 14 illustrates an operation of the present invention from a perspective of director server.

FIG. 15 illustrates an operation of the present invention from a perspective of director server gathering delivery statistics from a particular participant manager.

10 FIG. 16 illustrates an operation of the present invention from a perspective of director client.

FIG. 17 illustrates an operation of an autodiscovery algorithm from the perspective of an existing participant manager according to a preferred embodiment of the present invention.

15 ***Detailed Description of the Preferred Embodiments***

The present invention is directed toward a system and method for multicasting data in a network communication system. In particular, the present invention provides a system and method for managing, measuring, and controlling how information is delivered across a multicast-enabled network communication system (*i.e.*, “multicast environment”). While the present invention is described
20 herein using a “stadium analogy,” it will be apparent from the following discussion

how the present invention contemplates delivery of any form of data to multiple recipients in a multicast environment in an authenticated, reliable and controlled manner.

System Overview

5 FIG. 1 illustrates a multicast environment 100 according to the present invention, includes a multicast-enabled network communication system 105. Multicast environment 100 may include at least one content provider 110 (illustrated as a content provider 110A and a content provider 110B), a plurality of participants 120 (illustrated as a participant 120A, a participant 120B, and a
10 participant 120C), one or more participant managers 130 (illustrated as a participant manager 130A and a participant manager 130B), a director 140 and/or a ticket provider 150.

 FIG. 2 illustrates a stadium analogy 200 useful for describing multicast environment 100, particularly for describing its use to deliver an event 220.
15 Content providers 110 provide event 220 to stadium 210 for delivery to participants 120. Participants 120 acquire a ticket 240 to event 220 from ticket provider 150. Participants 120 present ticket 240 at a turnstile 230 to enter stadium 210 whereby they begin participating in event 220.

 Participant managers 130 located at strategic points within network
20 communication system 105 manage the delivery of event 220 to the participants 120. Director 140 oversees the delivery of event 220 by supervising participant managers 130, ensuring that event 220 is delivered to each participant 120.

Using turnstiles 230, participant managers 130 can determine which and how many of participants 120 participated in event 220 and can determine the duration of that participation. This information is collected and aggregated by participant managers 130 and maintained by director 140 for billing purposes or
5 for evaluating demographic information associated with participants 120 of event 220. Each of these aspects of multicast environment 100 is described in further detail below.

Multicast Environment

Multicast environment 100 includes network communication system 105
10 that is configured for multicasting content (*i.e.* events 220) from a single source (*i.e.*, stadium 210) to multiple recipients (*i.e.*, participants 120). In one embodiment of the present invention, multicast environment 100 operates on the Internet using well-established protocols, including various protocols for communicating via one or more wireless connections. In an alternate embodiment
15 of the present invention, multicast environment 100 operates on an entity's intranet using similar well-established network protocols. This entity may include, but is not limited to a company, a government, a government agency, an organization or any other entity that operates a private intranet or similar communication network.

Event

20 According to the present invention, event 220 is a time-sensitive delivery of an information stream to multiple recipients. Preferably, event 220 is intended to arrive virtually simultaneously at each participant 120. Event 220 may comprise a

continuous information stream such as a video stream, an audio stream, or other form of continuous data stream, that is either "live" or pre-recorded. The information stream may also comprise one or more data files such as an image file, an application program, an application program update, a database, or other form of data file destined to multiple recipients. The information stream may also
5 comprise a conferencing information stream such as video teleconferencing, audio teleconferencing, collaborative working environments or other form of conferencing information stream; a news information stream such as various wire service information streams including UPI, API, etc.; equity and/or commodity
10 ticker information streams such as NYSE, NASDAQ, CBOE, etc.; and a gaming information stream for interactive multi-player network games.

Content Providers

Content providers 110 provide the content that is to be delivered to participants 120 in multicast environment 100, preferably from stadium 210 in the
15 form of event 220. More particularly, content providers 110 provide an information stream that is to be multicasted to participants 120. In general, content providers 110 may provide any form of information stream that may benefit from delivery in a multicast environment 110, particularly where identical or similar information is to be simultaneously (or virtually simultaneously) delivered to
20 multiple participants 120.

Content providers 110 may include commercial webcasting companies as well as enterprises. Examples of commercial company information streams

include, but are not limited to, financial and technical community briefings and conferences, sporting events, music concerts, movie premieres, news services and on-line learning. Examples of enterprise information streams include, but are not limited to, all-hands briefings and announcements, management communications,
5 employee training, and customer service communications.

According to a preferred embodiment of the present invention, content providers 110 establish a web page for the information stream that can be accessed via a web browser. Preferably, from the perspective of participants 120, the information stream is accessed as event 220 through stadium 210. Content
10 provider 110 provides director 140 with an address (preferably a URL address) for the web page associated with event 220 discussed above to accomplish this aspect of the invention. Director 140 reformats this URL address as a Stadium URL address (“SURL”) for operation with multicast environment 100 and returns the
15 SURL to content provider 110 to be included in the web page. Further aspects of the interaction between content provider 110 and multicast environment 100 are discussed in further detail below.

Stadium

FIG. 7 illustrates stadium 210 according to one embodiment of the present invention. According to the present invention, stadium 210 is a virtual stadium.
20 Stadium 210 may include one or more sections 710 (illustrated as a first section 710A, a second section 710B, a third section 710C, and a fourth section 710D). In one embodiment of the present invention, each section 710 is associated with a

different event 220 being offered in stadium 210 at that particular time. In an alternate embodiment of the present invention, each section 710 is associated with a different class of service associated with the delivery of a particular event 220. Such classes of service may include, for example, encoding data at different bit rates for delivery via a cable modem so that a lower class of service might receive data at 56kbps and a higher class of service might receive data at 300kbps. Other forms of discriminating classes of service are available as would be apparent.

Events 220 offered in stadium 210 offered at any particular time may all originate from a particular content provider 110. Alternately, events 220 offered in stadium 210 may originate from different content providers 110.

The present invention also contemplates multiple stadiums 210 each offering multiple events 220 or multiple classes of service for a particular event 220 at any particular time. For example, one stadium 210 may offer various live baseball games, while another stadium 210 may offer various inspirational speakers. Events offered via various stadiums 210 and within particular stadiums are numerous and may be organized in various manners as would be apparent.

Participants

Participants 120 are those users that receive event 220 (*i.e.*, recipients of the information stream) via network communication system 105. Participants 120 may be consumers in the event that content provider 110 is a commercial company, or employees in the event that content provider 110 is an enterprise.

Preferably, participants 120 perceive that they receive event 220 from stadium 210. In a preferred embodiment of the present invention, participants 120, upon accessing stadium 210 to participate in event 220, are redirected to content provider 110, or more particularly, to a multicast-enabled URL address from which event 220 is delivered. In some embodiments of the present invention, content providers 110 provide event 220 to stadium 210 *a priori*, and stadium 210 subsequently directs participants 120 to the multicast enabled URL address.

Participants 120 generally receive the information stream via a suitable receiving device such as, but not limited to, a computer workstation, a PDA, a memory device (*e.g.*, an MP3 player, a memory stick, etc.), a cellular telephone, a set-top box, or any other form of electronic device capable of receiving information from network communication system 105, including those employing one or more wireless connections to network communication system 105. In one embodiment of the present invention, the receiving device includes a web browser that operates in conjunction with an event renderer such as a media player (*e.g.*, Real Player™, Microsoft Windows' Media Player™, etc.) to render event 220 for use by participant 120. In an alternate embodiment, the event renderer is delivered prior to or as part of event 220. For example, if event 220 comprises an application program upgrade, event 220 may also include or be accompanied by a self-installing event renderer that installs the upgrade on participants' receiving device. The interaction between participants 120 and multicast environment 100 is discussed in further detail below.

Participant Managers

Participants 120 are managed and organized in multicast environment 100 by one or more participant managers 130 located at various strategic points within the network communication system. Preferably, participant managers 130 are
5 organized within multicast environment 100 in a hierarchy 300 as illustrated in FIG. 3. Hierarchy 300 includes one or more levels of participant managers 130. Each level may organize and manage one or more lower levels of participant managers 130 and/or one or more participants 120. Preferably, multicast environment 100 includes up to 255 levels of participant managers 130 with any
10 number of participant managers 130 resident at each level. Other embodiments include fewer or more levels of participant managers 130 as would be apparent. Hierarchy 300 forms a tree topology with participants 120 at the “leaves,” various levels of participant managers 130 forming the “branches” and director 140 forming the “root.”

15 Hierarchy 300 of participant managers 130 manage and organize participants 120 in multicast environment 100 by directing network commands and control information downward from director 140, through the levels of participant managers 130, and ultimately to participants 120. Likewise, information associated with the delivery of the event is directed upward from participants 120,
20 through the levels of participant managers 130, which aggregate the information, to director 140 which monitors the delivery of the event. This process is discussed in further detail below.

In one embodiment of the present invention, hierarchy 300 is formed on a geographic basis. As illustrated in FIG. 3, hierarchy 300 includes a regional (*e.g.*, West Coast) participant manager 310 that manages and organizes three state participant managers 320 within that region, namely a California participant manager 320A, an Oregon participant manager 320B, and a Washington participant manager 320C. Each of these state participant managers 320 may include one or more district participant managers 330. As illustrated in FIG. 3, California participant manager 320 includes at least a Central California participant manager 330. Other district participant managers 330 may be included but are not illustrated for purposes of clarity.

Each district participant manager 330 may further include one or more locality participant managers 340. As illustrated in FIG. 3, Central California participant manager 330 includes a San Francisco participant manager 340A, a San Jose participant manager 340B, and an Oakland participant manager 340C. Various additional lower levels of granularity may be included in hierarchy 300. However, in this illustration, each locality participant manager includes one or more participants 120. As illustrated in FIG. 3, San Francisco participant manager 340A includes a participant 350A, a participant 350B, and a participant 350C; San Jose participant manager 340B includes a participant 350D; and Oakland participant manager 340C includes a participant 350E and a participant 350F.

It should be understood that the terms “regional,” “state,” “district,” and “locality” are used herein for purposes of illustration and not as specifying any particular method of organizing participants 120. As would be apparent, various

mechanisms for organizing participants 120 and participant managers 130 into hierarchy 300 are available and might be used in various circumstances.

Preferably, participant managers 130 are located at various strategic points within the network communication system 105. When network communication system 105 includes the Internet, these strategic locations may include various points-of-presence (“POPs”) within the Internet, preferably located near participants 120. Alternately, when network communication system 105 includes an Intranet, these strategic locations may include various subnets, departments, buildings, or geographic locations within the intranet. Of course these locations may also include a combination of strategic points within various intranets operating within the overall framework of the Internet as would be apparent.

Director

Preferably, each stadium 210 in multicast environment 100 is associated with a director 140. However, in alternate embodiments of the present invention, director 140 may be associated with several stadiums 210. Director 140 oversees and manages the delivery of event 220 from stadium 210 to participants 120. Director 140 also provisions tickets 240 for events 220 in stadium 210. In a preferred embodiment of the present invention, director 140 is comprised of two components: a director server 410 and a director client 420 as illustrated in FIG. 4. Each of these is now described in further detail.

Director Client

According to a preferred embodiment of the present invention, director client 420 is one component of director 140. Director client 420 preferably comprises a web-based monitoring tool that provides dynamic, real-time views of the delivery of event 220 within multicast environment 100. In particular, director client 420 provides information regarding participants 120 as well as delivery statistics associated with participants 120 at various levels within hierarchy 300. Director client 420 also provides interactive control over participant managers 130 and participants 120 within hierarchy 300, including the ability to delete a particular participant 120 from event 220.

Director client 420 also operates as an interface to create event 220, edit event 220, remove event 220 and other management operations associated with event 220. Preferably, either content provider 110 or a system operator may access director client 420 to perform these operations.

FIG. 5 illustrates an exemplary graphical user interface (“GUI”) associated with director client 420 for providing information regarding the delivery of event 220. More particularly, FIG. 5 illustrates a GUI 500 that represents various performance and information aspects of the delivery of event 220 (referred to herein as delivery statistics) to one or more participants 120 arranged in a left GUI portion 510 and a right GUI portion 570.

Left GUI portion 510 includes a GUI tree structure 515 corresponding to hierarchy 300. GUI tree structure 515 represents the various levels of hierarchy

300 in a familiar “directory tree structure” such as that employed in various “file manager” applications. In this example, GUI tree structure 515 corresponds to hierarchy 300 for West Coast participant manager 310. Thus, a first level structure indicator 520A corresponds to California participant manager 320A; a first level structure indicator 520B corresponds to Oregon participant manager 320B; and first level structure indicator 520C corresponds to Washington participant manager 320C. Each first level structure indicator 520 may include information 521 (such as information 521A) that identifies its corresponding participant manager 130 and/or that summarizes aggregate delivery statistics corresponding to participants managers 130 attached beneath it.

Each first level structure indicator 520 may include one or more second level structure indicators 525. For example, a second level structure indicator 525A corresponds to Central California participant manager 330. Each second level structure indicator 525 may include information 526 that identifies its corresponding participant manager 130 and/or that summarizes aggregate delivery statistics corresponding to participants managers 130 attached beneath it.

Likewise, each second level structure indicator 525 may include one or more third level structure indicators 530. For example, second level structure indicator 525A includes a third level structure indicator 530A corresponding to San Jose participant manager 340BA, a third level structure indicator 530B corresponding to San Francisco participant manager 340A, and a third level structure indicator 530C corresponding to Oakland participant manager 340C. Again, each third level structure indicator may include information 531 that

identifies its corresponding participant manager 130 and/or that summarizes aggregate delivery statistics corresponding to participant managers 130 attached beneath it.

Although described above as being associated with participant managers
5 130, any of structure indicators 520, 525, 530 may correspond to a particular participant 120. Likewise, each of structure indicators 520, 525, 530 may include information that identifies its corresponding participant 120 and/or that provides delivery statistics corresponding to participant 120.

As illustrated in FIG. 5, third level structure indicator 530B and its
10 information 531B are highlighted. Preferably, when any of particular structure indicators 520, 525, 530 are highlighted in left GUI portion 510, information associated with the corresponding participant manager 130 is presented in right GUI portion 570. Thus, as illustrated in FIG. 5, right GUI portion 570 includes information corresponding to San Francisco participant manager 340A.

15 In a preferred embodiment of the present invention, right GUI portion 570 provides information associated with participants 120 organized below the corresponding participant manager 130 associated with the highlighted structure indicator in left GUI portion 510. In this example, right GUI portion 570 includes information corresponding to participants 350A, 350B and 350C organized below
20 San Francisco participant manager 340A. If structure indicator 525A were highlighted in FIG. 5, right GUI portion 570 would include information corresponding to participants 350A-F.

In a preferred embodiment of the present invention, the information corresponding to participants 120 displayed in right GUI portion 570 includes a ticket ID 540 and a duration 545. Ticket ID 540 corresponds to an identification number of ticket 240 granted to a particular participant 120 whereby the particular participant was granted access to event 220 as will be discussed in further detail. Duration 545 corresponds to an amount of time that the particular participant 120 participated in the event (*i.e.*, received the information stream). In some embodiments of the present invention, duration 545 may correspond to an amount of data (expressed in bytes or other suitable measure of data) delivered to the particular participant 120. Other information corresponding to participants 120 may be included as would be apparent.

As illustrated in FIG. 5, a particular ticket ID 550 is highlighted. In a preferred embodiment of the present invention, further information 565 is displayed in right GUI portion 570, for highlighted ticket ID's such as ticket ID 550. In one embodiment of the present invention, further information 565 includes demographic data 560 associated with the particular participant 120. This demographic information may include name, address, age, gender, household income, occupation, telephone number, and various other demographic information as would be apparent. In a preferred embodiment of the present invention, the particular participant 120, in exchange for ticket 240 to event 220, may have provided this demographic information.

System operators and content providers 110 may access director client 420 to monitor the delivery of event 220. Likewise, system operators and content

providers 110 may access director client 420 after delivery of event 220 to conduct pre-processing or post-processing on the delivery of event 220.

In a preferred embodiment of the present invention, director client 420 is used to determine demographic information associated with the delivery of a particular event 220. This demographic information may be used to target a direct advertising campaign or provide special offers to a subset of participants 120 on a demographic and/or geographic basis. Additional aspects of this embodiment are described in further detail below.

Director Server

Director server 410 provides various organizational and management functions of director 140, namely provisioning event 220, controlling delivery of event 220, logging delivery of event 220, and reporting delivery of event 220. Each of these are now described in further detail.

Event Provisioning

Director server 410 provides management tools to provision stadium 210 for events 220. Provisioning stadium 210 for events includes allocating, dispensing, and tracking tickets 240. In this regard, director server 410 may determine a maximum number of tickets 240 that can be dispensed by a particular content provider 110. This controls an amount of access the particular content provider 110 has to stadium 210. Director server 410 may also determine a maximum number of tickets 240 that can be dispensed for a particular event 220 in stadium 210. This controls a number of participants 120 to the particular event 220

and limits their attendant system requirements imposed on network communication system 105 (e.g., server capacity, bandwidth, etc.). Director server 140 may also determine a maximum number of tickets 240 that can be dispensed for any particular point in time per participant manager 130. This controls an amount of

5 participants 120 accessing a particular point of presence in network communication system 105 to again limit the burden imposed on that particular point of presence (e.g., server capacity, number of modems, network bandwidth, etc.). Director server 140 may also determine a maximum number of tickets 240 that may be dispensed to participants 120 organized below any particular

10 participant manager 130. By setting this maximum number to zero for some participant managers 130 and to a non-zero number for other participant managers 130, the director server 410 may control a geographic region (e.g., a country, a state, a county, a city, etc.) in which participants 120 can access event 220.

In a preferred embodiment of the present invention, director server 410

15 maintains a database of all tickets 240 that have been dispensed in multicast environment 100 and used within stadium 210. This database may include information associated with the particular participant 120 to which each ticket 240 is dispensed. These tickets 240 are maintained on a per event as well as a per participant manager for purposes of planning and provisioning addition resources

20 in multicast environment 100.

Controlling Delivery of Event

Director server 410 also controls delivery of event 220 using a delivery method referred to as the SURL. The SURL is generated by director server 410 and resides on the web page provided by content provider 110 for a particular event 220. The SURL is implemented using a Java Applet, Servlet, HTML, or a combination of any of these or similar code scripting languages.

FIG. 6 illustrates an operation of this delivery method as it delivers the particular event 220 to participant 120. In a step 610, participant 120 invokes the SURL by attempting to access the particular event on the web page. In a step 620, the delivery method determines whether participant 120 has turnstile 230. In a preferred embodiment of the present invention, the delivery method determines whether a particular directory is present on the receiving device of participant 120 and that files associated with turnstile 230 reside therein. Other mechanisms for determining whether participant 120 has turnstile 230 are available as would be apparent. If participant 120 has a turnstile, processing continues at a step 635; otherwise, in a step 630, turnstile 240 is downloaded and installed at participant 120.

In step 635, turnstile 230 is invoked. In a step 640, turnstile 230 determines whether participant 120 has ticket 240 corresponding to the particular event 220. In a preferred embodiment of the present invention, turnstile 230 determines whether a registry (such as a Windows™ registry) includes ticket 240 corresponding to the particular event 220. In addition, turnstile 230 authenticates

ticket 240 to determine whether ticket 240 is a valid one. If participant 120 has ticket 240 corresponding to the particular event 220, processing continues at a step 660. Otherwise, if participant 120 does not have ticket 240, in a step 650, turnstile 230 directs participant 120 to an appropriate location where ticket 240 can be
5 acquired such as director server 410, content provider 110, ticket provider 150, or some other source of ticket 240.

In step 660, after determining that participant 120 has turnstile 230 and ticket 240, turnstile 230 may direct participant 120 to access a multicast source associated with event 220. In a preferred embodiment of the present invention, this
10 access launches an event renderer thereby initiating delivery of event 220.

Logging Delivery of Event

Director server 410 also logs delivery of event 220. In particular, director server 410 collects log information from each participant manager 130 and mediates them, preferably into an XML file referred to as a Content Delivery Log,
15 for each event 220 delivered. Content Delivery Log includes information associated with the delivery of event 220 to each participant 120. Preferably, this information includes an event identification, a ticket identification, a user identification for billing, a time on event, a time off event, a duration of event, and a reason for leaving event (*e.g.*, system failure, voluntary departure, etc.). Other
20 information may be included in the Content Delivery Log as would be apparent.

Reporting on Delivery of Event

Director server 410 also provides various reports regarding event 220 to either system operators (*e.g.*, stadium owners) or content providers 110. As would be apparent, various reports may be generated from data and delivery statistics associated with event 220, stadium 210, participants 120, participant managers 130, and/or content provider 110.

For example, one such report may provide information regarding ticket allocation with respect to a particular content provider 110 operating multiple events 220 in stadium 210. This report may provide: a number of tickets available to be distributed for all future events; a number of tickets allocated for current or pending events; a number of tickets to past or current events that were allocated but not dispensed to participants; a number of tickets that were dispensed to and actually used by participants; and a number of tickets that were dispensed to but not used by participants.

Another report may provide post-event information on the allocation of tickets to an individual event with the stadium. This report may provide: a number of tickets that were allocated to the event but were not dispensed; the number of tickets that were dispensed to and used by participants; and the number of tickets that were dispensed to but not used by participants.

Another report may provide pre-event information on the number of tickets that have been allocated and dispensed for a single event within a particular geographic region (*i.e.*, within the domain of a particular participant manager).

Still another report may provide pre-event statistics on the number of tickets that have been allocated and dispensed for all events within a particular geographic region.

Yet still another report may provide post-event information on the number
5 of participants that actually used their ticket to participate in the event by geographic region. Another report may provide post-event information on the duration of participation for each participant by geographic region. Still another report may provide a number of tickets allocated and used based on the classification of the ticket.

10 Various other reports may be generated including summary reports including any or all of the aforementioned reports as would be apparent.

Tickets

Tickets 240 provide a mechanism in multicast environment 100 for
identifying, authenticating, measuring, and controlling participants 120
15 participating in events 220 within stadium 210. Each ticket 240 includes a unique identifier, preferably encrypted by itself or with other information, that is used to authenticate ticket 240, to provide security to event 220, and to associate any demographic or other participant information gathered by the system.

Tickets 240 may be of different types including, but not limited to, a single
20 event ticket, a multi-event ticket (e.g., a season ticket), a time-based ticket (e.g., a three day pass), or a subscription ticket (e.g. weekly or monthly access). Different types of tickets 240 may specify different manners of delivery such as delivery at a

regularly scheduled time versus delivery “on demand”. Different types of tickets 240 may also specify one or more different classes of service (e.g. gold or platinum levels).

In a preferred embodiment of the present invention, ticket 240 includes first 5 authentication information and second authentication information. First authentication is used by turnstile 230 to locally determine whether ticket 240 is a valid ticket (*i.e.*, one provided by director server 410). Second authentication is used by participant managers 130 to actually authenticate that ticket 240 was provided to the particular participant 120 in possession of ticket 240. Ticket 240 10 may also include information associated with participant 120, information regarding a class of service, an address of participant managers 130 to which turnstile 230 should attach, and/or an address associated with advertising information to be provided to participant 120 during event 220.

As described above, in order for a participant 120 to participate in a 15 particular event 220, participant 120 must acquire a ticket 240 to the particular event 220. Ticket 240 may be acquired at various locations within multicast environment 100 including ticket provider 150, content provider 110, and/or stadium 210. Ticket 240 may be acquired “in advance” or “at the door.” Preferably, tickets 240 are acquired at a director server 410 associated with 20 stadium 210 hosting event 220. Alternately, any of these locations may direct participant 120 to a single source of tickets 240 such as ticket provider 150. According to the present invention, ticket provider 150 includes any source of tickets 240 including commercial “bricks and mortar” sources.

Participant 120 may acquire a ticket 240 in various manners. In one embodiment of the present invention, participant 120 acquires ticket 240 by providing various demographic or survey information associated with participant 120. In exchange for this information, ticket provider 150 provides participant 120 with ticket 240.

In an alternate embodiment of the present invention, participant 120 acquires ticket 240 by providing payment information in exchange for ticket 240. Payment information may include billing information or an actual form of monetary compensation (e.g., cash, e-currency, etc.). In another embodiment of the present invention, participant 120 acquires ticket 240 by providing both demographic information and payment information. In this embodiment of the present invention, the payment information may entitle participant 120 to a higher class of service over those participants 120 only providing demographic information. In some embodiments of the present invention, ticket 240 is distributed to participant 120 with no payment information or demographic information required.

Turnstile

Turnstile 230 functions as a gatekeeper to stadium 210 and event 220. Only those participants 120 with an appropriate ticket 240 are allowed to enter stadium 210 and participate in event 220.

In a preferred embodiment of the present invention, turnstile 230 operates as an interface between participant 120 and content provider 110 (or other source

of event 220). Turnstile 230 also operates as an interface between participant 120 and participant manager 130. Preferably, turnstile 230 is a plug-in (or similar code portion) that is downloaded from director server 410 and installed at participant 120.

5 FIG. 8 illustrates a relationship among participants 120, turnstiles 230, participant managers 130, and content providers 110. As illustrated in FIG. 8, participants 120 receive event 220 from content provider 110 via a multicast-enabled network communication system 105 (illustrated as solid lines in FIG .8). Turnstiles 230, resident at each participant 120 monitor the delivery of event 220
10 and communicate delivery statistics upstream through a hierarchy 300 of participant managers 130 to director 140 via a separate protocol layer on network communication system 105 referred as a LEAP protocol (illustrated as dashed lines in FIG .8).

Turnstile 230 identifies, authenticates, classifies, and controls participants
15 120 and their ability to access events 220. Turnstile 230 also monitors use by measuring a duration of time participant 120 accessed event 220 and/or an amount of data participant 120 received from event 220.

LEAP Protocol

The LEAP protocol implements a signaling and transport protocol for
20 managing events 220 in stadium 210. The LEAP protocol is a light-weight transaction protocol built on top of a User Datagram Protocol (“UDP”). The LEAP protocol enables unicast as well as multicast transactions. Most transactions

within the LEAP protocol are reliable transactions. That is, each transaction is verified as successful or failed. This may be accomplished in various manners as would be apparent.

The LEAP facilitates many of the communications between components of
5 multicast environment 100. More particularly, the LEAP protocol operates on turnstile 230, participant managers 130, and director server 410 to provide autodiscovery, self-organization, and communication among these components.

For example, turnstile 230, equipped with ticket 240, notifies multicast environment 100 of its desire to participate in event 220 by sending a "JOIN"
10 message within the LEAP protocol to a particular participant manager 130 identified in ticket 240. The particular participant manager 130 determines whether ticket 240 is valid. If ticket 240 is a valid ticket, participant manager 130 responds with a "JOIN REPLY" message within the LEAP protocol indicating a successful joining of participant 120 to event 220. If ticket 240 is an invalid ticket,
15 participant manager 130 responds with a JOIN REPLY message indicating that the joining failed and participant 120 is unable to gain access to event 220. When participant 120 leaves event 220, turnstile 230 sends a "LEAVE" message to the particular participant manager 130. Participant manager 130 responds with a "LEAVE ACKNOWLEDGEMENT" message.

20 The LEAP protocol is also used between and among participant managers 130 for various communications. A lower level participant manager 130 (also referred to as a "downstream" participant manager 130) associates itself with a

higher level participant manager 130 (also referred to as an “upstream” participant manager 130) by sending an “ATTACH” message within the LEAP protocol to the upstream participant manager 130. The upstream participant manager 130 responds by sending an “ATTACH ACKNOWLEDGEMENT” message within the LEAP protocol to the lower level participant manager 130. Similarly, a participant manager 130 disassociates itself with another participant manager 130 by sending a “DETACH” message within the LEAP protocol. The participant manager 130 being disassociated responds by sending a “DETACH ACKNOWLEDGEMENT” message within the LEAP protocol.

10 Data is exchanged between components by using a “DATA” message. A requestor sends the “DATA” message to a requestee for data. The requestee responds with the requested data in a “REPLY” message back to the requestor. Many information exchanges are used in multicast environment 100. Examples of these include: director server 410 requesting that a particular participant manager 130 provide a list of all participants 120 attached to it; a downstream participant manager 130 requests that an upstream participant manager provide a list of all events 220 it has defined; and a participant manager 130 requests that a particular participant 120 provide statistics about itself.

20 Some information exchanges in the LEAP protocol are not transactions but controlled messages that flow upstream. These messages flow upstream at some requested configurable rate from a downstream entity such as a participant 120 or lower level participant manager 130 to a upstream entity such as a higher level participant manager 130 or director server 410. Examples of these messages

include: aggregate participant statistic messages, dynamic topology messages indicating changes in hierarchy 300, and event specific statistic messages.

Another type of information exchange in the LEAP protocol are referred to as casts. Casts are multicast transactions where the REPLY messages are aggregated to indicate success or failure of the cast. FIG. 9 illustrates a participant manager hierarchy 900 operating with a cast transaction. Hierarchy includes a root participant manager 910, one or more internal participant managers 920, and one or more edge participant managers 930. Root participant manager 910 is the highest level participant manager in hierarchy 900. Internal participant managers 920 represent one or more levels of mid-level participant managers. Edge participant managers 930 represent the lowest level participant managers in hierarchy 900. Attached to edge participant managers 930 are participants 120.

In the cast transaction, root participant manager 910 multicasts a "DATA" message to all other participant managers in hierarchy 900. Edge participant managers 930 that received the multicasted DATA message respond by sending an affirmative "REPLY" message upstream, in this example, to one or internal participant managers 920. Thus, if edge participant manager 930B receives the multicasted DATA message, it sends an affirmative "REPLY" message to internal participant manager 920A. Similarly, if edge participant manager 930F receives the multicasted DATA message, it sends an affirmative "REPLY" message to internal participant manager 920B.

Internal participant managers 920 only respond to the multicasted DATA message if and when all their downstream participant managers have responded. In this example, internal participant manager 920A sends an affirmative "REPLY" message to root participant manager 910 only after receiving affirmative REPLY

5 messages from each of participant managers 930A-C. Likewise, internal participant manager 920B sends an affirmative "REPLY" message to root participant manager 910 only after receiving affirmative REPLY messages from each of participant managers 930D-F. The cast transaction is complete when a REPLY message has been received from all participant managers.

10 In the event that some participant managers fail to receive the initial DATA message, the cast fails, preferably via a timeout waiting on the REPLY message. In a preferred embodiment of the present invention, a localized retransmission of the DATA message is sent. In other words, an upstream participant manager that received the DATA message and that has not received a REPLY from a

15 downstream participant manager sends the DATA message directly to that downstream participant manager.

Autodiscovery Algorithm

According to the present invention, participant managers 130 form themselves into hierarchy 300 using an autodiscovery algorithm 1000 illustrated in

20 FIG. 10 and FIG. 17. Autodiscovery algorithm defines the process by which participant managers 130 discover their relationships to other participant managers in hierarchy 300.

Before discussing the algorithm itself, some characteristics of participant managers 130 are briefly described. Each participant manager 130 is assigned a level within hierarchy 300. As discussed above, this level preferably varies between 0 (the lowest level) and 255 (the highest level). These levels are assigned .

5 during system design and implementation so that the lowest level participant managers 130 preferably reside near participants 130 both logically (in terms of network address or number of “hops”) and geographically (in terms of physical location). Higher level participant managers 130 are similarly organized around the lower level participant managers 130. One example of such organization was

10 described above with respect to FIG. 3.

Each participant manager 130 is likewise assigned a network address. While it would seem simple to merely arrange hierarchy 300 by having various lower level participant managers 130 report directly to a particular higher level participant manager 130 via this address, such an arrangement does not provide the

15 self-organizing or self-healing features of the present invention. For example, if the particular higher level participant manager 130 fails, the lower level participant managers 130 assigned to it have no mechanism for reestablishing themselves in hierarchy 300. Similarly, the addition of a new participant manager 130 to hierarchy 300 would require that at least some of the lower level participant

20 managers 130 be manually reassigned.

Autodiscovery algorithm 1000 however, provides both self-organizing and self-healing features by allowing participant managers 130 to locate one another and arrange themselves in hierarchy 300. A preferred embodiment of

autodiscovery algorithm 1000 with respect to a new participant manager 130 joining hierarchy 300 is now described with reference to FIG. 10.

In a step 1010, the new participant manager 130 casts an "ANNOUNCE" message on a multicast address within multicast environment 100. Preferably, this
5 multicast address is associated with a particular stadium 210 to which the new participant manager 130 is assigned. The new participant manager 130 is "new" in the sense that it is not yet a member of hierarchy 300 and is desirous of discovering its place therein. The ANNOUNCE message includes a unicast address and a level associated with the new participant manager 130 to which other participant
10 managers 130 should respond.

In a step 1020, the new participant manager 130 receives an "ANNOUNCE ACKNOWLEDGE" message from a replying participant manager 130. The ANNOUNCE ACKNOWLEDGE message includes a unicast address and a level associated with the replying participant manager 130.

15 In a step 1030, the new participant manager 130 determines whether the level of the replying participant manager 130 is less than its own level. If so, the response is ignored, and processing continues at step 1020 to evaluate responses from other participant managers 130. Otherwise, processing continues at a step 1040.

20 In step 1040, the new participant manager 130 determines whether the level of the replying participant manager 130 is greater than the level of an upstream participant manager 130 that the new participant manager 130 believes is the next

higher level above his. This participant manager 130 is referred to as a current upstream participant manager and identifies the participant manager 130 to which the new participant manager is attached in hierarchy 300. If the level of the replying participant manager 130 is greater than the level of the current upstream participant manager, then the response is ignored, and processing continues at step 1020 to evaluate responses from other participant managers 130. Otherwise, processing continues at a step 1050.

In step 1050, the new participant manager 130 determines whether the level of the replying participant manager 130 is less than the level of the current upstream participant manager 130. If so, processing continues at a step 1070. Step 1070 is arrived at when the replying participant manager 130 has a level in between that of the new participant manager 130 and that of the current participant manager 130. This would indicate that the replying participant manager 130 should be identified as the current participant manager 130. In step 1070, the replying participant manager is identified as the current participant manager 130. In a preferred embodiment, this is accomplished by sending an ATTACH message to the replying participant manager 130 and a DETACH message to the current participant manager 130. Once step 1070 is completed, processing continues at step 1020 to evaluate responses from other participant managers 130.

If in step 1050 the level of the replying participant manager 130 is not less than the level of the current upstream participant manager 130, processing continues at a step 1060. Step 1060 is arrived at when the level of the replying participant manager 130 and that of the current upstream participant manager 130

are the same. When this occurs, the new participant manager 130 preferably attaches itself to the closest of the two same level participant managers 130. In step 1060, the new participant manager 130 determines whether the replying participant manager 130 is closer than the current upstream participant manager

5 130. This may be accomplished by determining a number of hops between the new participant manager and each of the same level participant managers assuming that participant managers with fewer hops between one another are located physically closer to one another than those with more hops. Ties in the number of hops are resolved in favor of the participant manager with the closest network

10 address.

In step 1060, if the replying participant manager 130 is closer than the current upstream participant manager, then processing continues at step 1070 where the replying participant manager is identified as the current participant manager as described above. Otherwise, processing continues at step 1020 to

15 evaluate responses from other participant managers 130. Autodiscovery algorithm 1000 is repeated until the new participant manager no longer receives further ANNOUNCE ACKNOWLEDGE messages. This portion of autodiscovery algorithm 1000 establishes the upstream connections of the new participant manager 130 within hierarchy 300.

20 FIG. 17 illustrates autodiscovery algorithm 1000 from the perspective of a participant manager 130 already existing in hierarchy 130. This portion of autodiscovery algorithm 1000 now described establishes the downstream connections of the new participant manager 130 within hierarchy 300.

In a step 1710, an existing participant manager 130 receives an ANNOUNCE message from the new participant manager 130. The participant manager 130 is "existing" in the sense that it is already attached in hierarchy 300. In a step 1720, the existing participant manager 130 determines whether the level of the new participant manager 130 is less than its own level. If so, in a step 1720, the existing participant manager 130 responds by sending an ANNOUNCE ACKNOWLEDGEMENT message as discussed above. Otherwise processing continues at a step 1740.

In step 1740, the existing participant manager 130 determines whether the level of the new participant manager 130 is less than the level of the current upstream participant manager 130. If so, the new participant manager 130 is closer than the current upstream participant manager 130, and processing continues at a step 1750. Otherwise, the ANNOUNCE message from the new participant manager 130 is ignored.

In step 1750, because the new participant manager 130 is closer than the current upstream participant manager 130, the existing participant manager 130 detaches from the current upstream participant manager 130. In a step 1760, the existing participant manager 130 restarts autodiscovery algorithm 1000 by casting an ANNOUNCE message in step 1010.

As an example, hierarchy 300 may be obtained using autodiscovery algorithm 1000 with the following levels assigned to each of the components: for director 140, LEVEL = 255; for West Coast participant manager 310, LEVEL =

200; for California participant manager 320A, Oregon participant manager 320B, and Washington participant manager 320C, LEVEL = 150; for Central California participant manager 330, LEVEL = 80; for San Francisco participant manager 340A, San Jose participant manager 340B, and Oakland participant manager 340C, LEVEL = 20; and for participants 350, LEVEL = 0.

System Operation

The operation of multicast environment is now described from a perspective of each of the following components: participant 120, turnstile 230, participant manager 130, director server 410, and finally, director client 420.

10 *Participant's Perspective*

FIG. 11 illustrates an operation 1100 of multicast environment 100 from a perspective of a participant 120 according to one embodiment of the present invention. In a step 1110, participant 120 preferably selects an event 220 from either a web page provided by content provider 110 or from stadium 210. In
15 alternate embodiments, participant 120 may be delivered a link to event 220 via an e-mail, a URL address or other mechanism.

In a step 1120, after selecting event 220, director server 410 determines whether participant 120 has turnstile 230 installed. In a preferred embodiment of the present invention, this accomplished using the SURL delivery method as
20 described above. If the SURL determines that turnstile 230 is installed processing continues at a step 1140. Otherwise, in a step 1130, participant 120 receives a turnstile 230 from director server 410.

In step 1140, in one embodiment, turnstile 230 determines whether participant 120 has a valid ticket 240 to event 220. In an alternate embodiment, the SURL determines if participant 120 has a valid ticket 240 to event 220. If turnstile 230 determines that participant 120 has a valid ticket, processing continues at a
5 step 1160. Otherwise, in a step 1150, participant 120 acquires a ticket 240 to event 220. In a preferred embodiment of the present invention, turnstile 230 directs participant 120 to a location where participant 120 may acquire ticket 240.

In step 1160, participant 120 accesses event 220, or more particularly, accesses a multicast address associated with event 220 as provided by the SURL
10 delivery method from director server 410. This access initiates delivery of event 220. In a step 1170, this access invokes turnstile 230 at participant 120 if not already invoked. In a step 1180, this access also preferably launches an event renderer at participant 120.

In a step 1190, participant's 120 participation in event 220 ends. In one
15 embodiment of the present invention, participant 120 closes the event renderer thereby ending participation in event 220. Alternately, the delivery of event 220 is completed thereby ending participation in event 220.

Turnstile's Perspective

FIG. 12 illustrates an operation 1200 of multicast environment 100 from a
20 perspective of turnstile 230 according to the present invention. In a step 1210, turnstile 230 is installed onto participant 120.

In a step 1220, turnstile 230 is invoked when participant 120 accesses event 220. In a first one embodiment of the present invention, turnstile 230 is invoked when participant 120 attempts to access a multicast address associated with event 220. In this embodiment, turnstile 230 prohibits participant 120 from joining the
5 multicast until various requirements (*e.g.* authorization from participant manager 130) are met.

In a second embodiment of the present invention, turnstile 230 is a wrapper (*e.g.*, Java applet) around the event renderer that intercepts signaling to the event renderer thereby prohibiting its launch, until the various requirements are met.

10 In a step 1230, turnstile 230 locates its corresponding participant manager 130 in hierarchy 300. In one embodiment of the present invention, turnstile 230 invokes autodiscovery algorithm 1000 as described above to seek out its corresponding participant manager. In an alternate embodiment of the present invention, turnstile 230 determines an address to its corresponding participant
15 manager 130 from ticket 240. In yet another alternate embodiment of the present invention, turnstile 230 is pre-assigned an address of the corresponding participant manager 130.

Once located in hierarchy 300, in a step 1235, turnstile 230 determines if participant 120 has a valid ticket 240. If not, in a step 1260, turnstile 230 directs
20 participant 120 to ticket provider 150. Otherwise, processing continues at a step 1240.

In step 1240, turnstile 230 forwards ticket 240 corresponding to event 220 to participant manager 130. In a preferred embodiment of the present invention, turnstile 230 forwards ticket 240 to participant manager 130 in conjunction with a JOIN message to participant manager 130.

5 In a step 1250, turnstile 230 receives a message from participant manager 130 indicating whether participant 120 has authorization to participate in event 220. Preferably, this is accomplished by receiving a JOIN REPLY message from participant manager 130. If the message from participant manager 130 indicates that participant 120 has authorization to participate in event 220, processing
10 continues at a step 1270. Otherwise, in step 1260, turnstile 230 directs participant 120 to ticket provider 150 where ticket 240 can be acquired.

In step 1270, the event renderer at participant 120 is launched as discussed above to render event 220. In a step 1280, turnstile 230 directs the event renderer to a source of the information stream associated with event 220, from which the
15 event renderer collects the information stream and renders it for participant 120.

In a step 1290, turnstile 230 periodically gathers delivery statistics associated with the delivery of event 220 to participant 120 and forwards them to participant manager 130. In one embodiment, turnstile 230 gathers and forwards delivery statistics at a start and end of event 220. In another embodiment, turnstile
20 230 gathers and forwards delivery statistic at a particular rate (*e.g.* once every two seconds). In yet another embodiment, turnstile 230 gathers and forwards delivery statistics when queried by director server 410 or one of participant managers 130.

Participant Manager's Perspective

FIG. 13 illustrates an operation 1300 of multicast environment 100 from a perspective of participant manager 130 according to the present invention.

In a step 1310, participant manager 130 locates itself with hierarchy 300.
5 Preferably, participant manager 130 does so using autodiscovery algorithm 100 as described above. Once so located, at some point in time, participant manager 130 receives a ticket 240 from turnstile 230 accompanied by a request to authenticate ticket 240.

In a step 1330, participant manager 130 attempts to authenticate ticket 240.
10 As discussed above, participant manager 130 uses second authentication information included in ticket 240 to verify that ticket 240 was provided to participant 120. In a step 1340, participant manager 130 notifies turnstile 230 of the results of the authentication.

In a step 1350, participant manager 130 collects delivery statistics from
15 turnstile 230. Preferably, participant manager 130 collects delivery statistics from each of turnstiles 230 below it in hierarchy 300. In a step 1360, participant manager 130 aggregates the delivery statistics from each of turnstiles 230. In a step 1370, participant manager 130 forwards the aggregated delivery statistics to the upstream participant manager 130. Preferably, each level of participant
20 managers 130 aggregate the delivery statistics so that they are correlated from root to leaf at any point in time within hierarchy 300.

For example, San Francisco participant manager 340A aggregates delivery statistics from participants 350A-C and forwards them to Central California participant manager 330. Similarly, Central California participant manager 310 aggregates delivery statistics from San Francisco participant manager 340A, San Jose participant manager 340B, and Oakland participant manager 340C and forwards them to California participant manager 320A. Each higher level participant manager 130 aggregates and forwards delivery statistics from those participant managers immediately beneath it until director server 410 receives the aggregated delivery statistics representing all participants 120 of a particular event 220.

The delivery statistics may include: an identification of event 220, an identification of participant manager 130 forwarding the statistics, a number of participants 120 directly attached to the participant manager 130, and an aggregate number of participants 120 indirectly attached to the participant manager 130 through lower level participant managers 130. Delivery statistics may also include a time a particular participant 120 joined particular event 220, and/or a time the particular participant 120 left the particular event 220

Director Server's Perspective

FIG. 14 illustrates an operation 1400 of multicast environment 100 from a perspective of director server 410 according to the present invention. After director server 410 is installed and started, in a step 1410, director server 410 locates the highest level participant managers 130 in hierarchy 300. In one

embodiment of the present invention, director server 410 locates the highest level participant managers 130 using autodiscovery algorithm 1000. For example, as illustrated in FIG. 3, director 140 (*i.e.*, director server portion 410) discovers West Coast participant manager 310 as well as any other participant managers 130 sharing the same level (not illustrated). In another embodiment of the present invention, director server 410 knows ahead of time the address of the highest level participant managers 130.

In a step 1420, content provider 110 creates event 220 at director server 410 using director client 420. In a step 1425, director server 410 creates and allocates tickets 240 for event 220. In a preferred embodiment of the present invention, creating event 220 includes describing all properties of event 220 including, but not limited to, advertisements associated with event 220 and to the provisioning of tickets 240 for event 220. In a step 1430, director server 410 notifies its participant managers 130 of event 220. In particular, director server 410 preferably supplies its participant managers 130 with an identification of event 220, a duration of event 220, and a duration during which participants 120 are allowed to join. In a step 1440, director server 410 provides a ticket 240 to participant 120 to access event 220.

In a step 1450, director server 410 periodically receives delivery statistics associated with event 220 from its participant managers 130. In a step 1460, director server 410 logs these delivery statistics as discussed above. In a step 1470, director server 410 provides director client 420 with the delivery statistics so that content provider 110 or a system operator can view the delivery statistics.

FIG. 15 illustrates an operation 1500 of director server 410 responding to a query from director client 420 with respect to delivery statistics associated with a particular participant manager 130 in hierarchy 300. In a step 1510, director server 410 receives a request from director client 420 regarding the delivery statistics
5 associated with one of participant managers 130 in hierarchy 300. Preferably, this request can be made for any of participant managers 310, 320, 330, and 340, or participants 350 in hierarchy 300.

In a step 1520, director server 410 queries the particular participant manager 130 directly. In a step 1530, director server 410 receives delivery
10 statistics directly from the queried participant manager 130. In a step 1540, director server 410 provides director client 420 with the requested delivery statistics associated with the particular participant manager 130 in hierarchy 300.

Director Client's Perspective

FIG. 16 illustrates an operation 1600 of multicast environment 100 from a
15 perspective of director client 420 according to the present invention. Operation 1600 is now described with reference to FIG. 5.

In a step 1610, after being installed at a user (*i.e.*, either content provider 110 or a system operator) director client 420 requests information regarding hierarchy 300 and delivery statistics associated therewith for a particular event 220
20 from director server 410. In a step 1620, director client 420 receives the requested information from director server 410. In a step 1630, director client 420 presents the user with a graphic user interface such as GUI 500 illustrated in FIG. 5.

Preferably, an initial presentation of hierarchy 300 in GUI 500 includes director server 410 and its participant managers 130 (*i.e.* the highest level participant managers 130 in hierarchy 300 directly connected to director server 410 such as West Coast participant manager 310). Furthermore, the aggregated delivery
5 information associated with event 220 is preferably presented in GUI 500 with respect to director server 410 with its constituent components broken down for each of participant managers 130.

In a step 1640, director client 420 receives a request from the user for delivery statistics with respect to a particular participant manager 130. In a step
10 1650, director client 420 forwards the request directly to the particular participant manager 130. In a step 1660, the director client 420 receives the requested delivery statistics directly from the particular participant manager 130. In a step 1670, director client 420 presents the user with an updated GUI 500 with the delivery statistics for the particular participant manager 130.

15 Director client 420 provides the user with several mechanisms for selecting the particular participant manager 130 for which delivery statistics are desired. According to one embodiment of the present invention, the user may expand GUI tree structure 515 by “clicking on” structure indicators 520, 525. As discussed above, the GUI aspect of the present invention operates in a familiar manner to the
20 “directory structure” of a typical “file manager.” In doing so, director client 420 requests more specific information with respect to each lower level participant manager 130 appearing in the expanded GUI tree structure 515. As GUI tree structure 515 is expanded further and further, delivery statistics are requested for

each corresponding lower level participant manager 130 until GUI tree structure 515 is fully expanded at which time delivery statistics are requested for individual participants 120.

5 According to one embodiment of the present invention, alone or preferably in combination with the embodiment just described, the user may also select a particular participant manager 130 or participant 120 within GUI tree structure 515 to obtain delivery statistics for that particular entity as described above.

Advertising Model

10 In one embodiment of the present invention, participants 120 acquire ticket 240 at least in part, by providing demographic information to ticket provider 150. Such demographic information may include, but is not limited to, a name, a geographic location, an address, an age, a gender, a household income, an occupation, a telephone number, an email address, a product preference, and various other demographic or marketing information as would be apparent.

15 According to the present invention, such demographic information is gathered by ticket providers 150 and collected at director server 410 and preferably organized using an identification of ticket 240 that was issued in exchange for the demographic information. This demographic information may be used to provide targeted advertising to participants 120 that correspond to a particular demographic
20 profile. Such a demographic profile may be generated at director client 420 and forwarded to director server 410 to obtain a list of participants 120 that match the

demographic profile for a particular event 220 or group of events 220 so that a particular advertisement may be sent to the list of participants 120.

In a preferred embodiment, one or more URL addresses are included with ticket 240 for delivering advertising information to participant 120 during event 220. One URL address may deliver a "stadium banner" that is delivered to all participants of event 220. Another URL address may deliver an advertising stream only to those participants 120 of event 220 that match a particular demographic profile.

For example, a particular advertiser may wish to target an advertisement towards 18-25 year old males living within a particular geographic area (e.g., San Francisco) during a particular event or type of event. The advertiser would access the present invention through director client 420 to create an appropriate demographic profile corresponding to this group of individuals and forward it to director server 410. Director server 410 subsequently includes a URL address corresponding to the advertisement in tickets 240 for the particular event 220 or type of event provided to participants 120 that the match the advertiser's demographic profile.

While the present invention has been described in terms of a preferred embodiment, other embodiments and variations are within the scope of the following claims.

What is claimed is

1 1. A system for multicasting an event to a plurality of participants
2 comprising:
3 a director having a multicast address associated therewith for delivering the
4 event to the plurality of participants;
5 a plurality of participant managers installed within a network
6 communication system and logically connected amongst themselves and to said
7 director thereby forming a hierarchy; and
8 a turnstile installed at and associated with each of the plurality of
9 participants, each turnstile logically connected to one of said plurality of
10 participant managers in said hierarchy.

1 2. The system of claim 1, wherein said turnstile sends delivery
2 statistics regarding said associated participant to said connected participant
3 manager; and
4 wherein said plurality of participant managers propagates said delivery
5 statistics upstream through said hierarchy to said director.

1 3. The system of claim 2, wherein said plurality of participant
2 managers aggregates said delivery statistics from those of said plurality of
3 participants beneath it in said hierarchy.

1 4. The system of claim 1, wherein said associated participant presents
2 said turnstile with a ticket to the event to gain access to the event.

1 5. The system of claim 4, wherein said turnstile determines whether
2 said ticket is valid.

1 6. The system of claim 5, wherein said turnstile forwards a valid ticket
2 to said connected participant manager for authentication.

1 7. The system of claim 6, wherein said connected participant manager
2 communicates authorization to said turnstile upon determining said ticket is
3 authentic.

1 8. The system of claim 1, wherein said director provides event
2 information to said connected participant manager.

1 9. The system of claim 1, wherein said turnstile prevents said
2 associated participant from receiving the event until a ticket associated with the
3 event is authenticated.

1 10. The system of claim 1, wherein said turnstile prevents said
2 associated participant from receiving the event until a ticket associated with the
3 event is determined to have been provided to said associated participant.

1 11. A method for organizing a plurality of participants and a plurality of
2 participant managers in a hierarchy under a director comprising:
3 receiving a message from a sending participant manager at a receiving
4 participant manager, said sending participant manager and said receiving
5 participant manager included in the plurality of participant managers, said message
6 including a level of said sending participant manager;
7 determining whether said receiving participant manager should be attached
8 in the hierarchy to said sending participant manager based on said level of said
9 sending participant manager and a level of said receiving participant manager; and
10 if so, attaching said receiving participant manager to said sending
11 participant manager thereby forming the hierarchy.

1 12. The method of claim 11, wherein said determining comprises
2 determining whether said receiving participant manager should be attached in the
3 hierarchy to said sending participant manager based on said level of said sending
4 participant manager, said level of said receiving participant manager, and a level of
5 an attached participant manager to which said receiving participant manager is
6 already attached.

1 13. The method of claim 12, wherein said determining comprises:
2 determining whether said level of said sending participant manager is less
3 than said level of said receiving participant manager.

1 14. The method of claim 12, wherein said determining comprises:
2 determining whether said level of said sending participant manager is less
3 than said level of said receiving participant manager; and
4 if not, determining whether said level of said sending participant manager
5 is greater than said level of said attached participant manager.

1 15. The method of claim 12, wherein said determining comprises:
2 determining whether said level of said sending participant manager is less
3 than said level of said receiving participant manager;
4 if not, determining whether said level of said sending participant manager
5 is greater than said level of said attached participant manager; and
6 if not, determining whether said level of said sending participant manager
7 is less than said level of said attached participant manager.

1 16. The method of claim 12, wherein said determining comprises:
2 determining whether said level of said sending participant manager is less
3 than said level of said receiving participant manager;
4 if not, determining whether said level of said sending participant manager
5 is greater than said level of said attached participant manager;

6 if not, determining whether said level of said sending participant manager
7 is less than said level of said attached participant manager; and
8 if not, determining whether said sending participant manager is closer to
9 said receiving participant manager than said attached participant manager.

1 17. The method of claim 11, further comprising:
2 multicasting an announce message to said sending participant manager
3 from said receiving participant manager.

1 18. The method of claim 17, further comprising:
2 sending an announce acknowledge message to said receiving participant
3 manager from said sending participant manager, wherein said message comprises
4 said announce acknowledge message.

1 19. The method of claim 18, further comprising:
2 determining whether a level of said receiving participant manager is less
3 than a level of said sending participant manager; and
4 if so, sending an announce acknowledge message to said receiving
5 participant from said sending participant manager, wherein said message
6 comprises said announce acknowledge message.

1 20. The method of claim 19, further comprising:
2 if said level of said receiving participant manager is not less than said level
3 of said sending participant manager, determining whether said receiving
4 participant manager is closer to said sending participant manager than a participant
5 manager to which said sending participant manager is already attached.

1 21. The method of claim 20, further comprising:
2 detaching said sending participant manager from said attached participant
3 manager; and
4 multicasting an announce message from said sending participant manager.

1 22. A method for gating a participant access to a multicasted event
2 comprising:
3 upon the participant attempting to access the event, prohibiting the
4 participant from joining the event;
5 determining whether the participant has a ticket;
6 if the participant has a ticket, determining whether said ticket is a valid
7 ticket;
8 if the participant has a valid ticket, receiving information as to whether said
9 ticket is an authentic ticket;
10 if the participant has an authentic ticket, allowing the participant to join the
11 event.

1 23. The method of claim 22, wherein said prohibiting comprises
2 intercepting an attempt by an event renderer located at the participant to join the
3 event.

1 24. The method of claim 22, wherein said prohibiting comprises
2 preventing an event renderer located at the participant from launching.

1 25. The method of claim 22, wherein said allowing comprises allowing
2 said event renderer to join the event.

1 26. The method of claim 24, wherein said allowing comprises allowing
2 said event renderer to launch.

1 27. The method of claim 22, further comprising directing the participant
2 to a ticket provider if the participant does not have a ticket.

1 28. The method of claim 22, further comprising directing the participant
2 to a ticket provider if the participant does not have a valid ticket.

1 29. The method of claim 22, further comprising directing the participant
2 to a ticket provider if the participant does not have an authentic ticket.

1 30. The method of claim 22, further comprising attaching the
2 participant to a director through a hierarchy of participant managers.

1 31. The method of claim 30, wherein said step of receiving information
2 as to whether said ticket is an authentic ticket comprises receiving said information
3 from said hierarchy.

1 32. The method of claim 30, wherein said step of receiving information
2 as to whether said ticket is an authentic ticket comprises receiving said information
3 from a participant manager in said hierarchy to which the participant is attached.

1 33. The method of claim 30, further comprising notifying said director
2 that the participant joined the event.

1 34. The method of claim 30, further comprising notifying said director
2 that the event ended.

1 35. The method of claim 30, further comprising notifying a participant
2 manager in said hierarchy to which the participant is attached that the participant
3 joined the event.

1 36. A method for multicasting an event to a plurality of participants
2 comprising:

3 determining whether a participant has a turnstile installed in response to a
4 request by said participant to participate in the event;
5 determining whether said participant has a valid ticket to the event;
6 directing said participant to a multicast source that delivers the event;
7 notifying a director that said participant has joined the event; and
8 monitoring the delivery of the event.

1 37. The method of claim 36, further comprising installing said turnstile
2 at said participant.

1 38. The method of claim 36, further comprising providing said valid
2 ticket to said participant.

1 39. The method of claim 36, further comprising notifying said director
2 when the event ends.

1 40. The method of claim 39, wherein said notifying comprises notifying
2 said director upon said participant closing the event.

1 41. The method of claim 39, wherein said notifying comprises notifying
2 said director upon completing the delivery of the event.

1 42. A method for aggregating delivery statistics comprising:
2 organizing a hierarchy having a lower level and a higher level, said lower
3 level including a plurality of lower level participant managers, said higher level
4 including a higher level participant manager, each of said plurality of lower level
5 participant managers attached to a participant;
6 receiving delivery statistics from each of said participants at each of said
7 plurality of lower level participant managers;

8 forwarding said received delivery statistics to said higher level participant
9 manager; and
10 aggregating said forwarded delivery statistics at said higher level
11 participant manager.

1 43. A method for providing a targeted advertisement to a participant of
2 a multicasted event comprising:
3 collecting demographic information from the participant;
4 determining geographic information associated with the participant;
5 creating a ticket for the participant, said ticket including advertising
6 information targeted to the participant based on at least one of said demographic
7 information and said geographic information;
8 providing said ticket to the participant; and
9 granting the participant access to the multicasted event using said ticket,
10 whereby the targeted advertisement is delivered to the participant during
11 the multicasted event based on said advertising information.

1 44. The method of claim 43, wherein said advertising information
2 includes a network address associated with the targeted advertisement.

1 45. The method of claim 43, wherein said advertising information
2 includes the targeted advertisement.

1 46. A tree structure in a graphic user interface comprises:
2 a first level structure indicator corresponding to and identifying a higher
3 level participant manager; and
4 a plurality of second level structure indicators organized under said first
5 level structure indicators, each of said second level structure indicators
6 corresponding to and identifying a lower level participant manager, each lower level

7 participant manager associated with at least one participant to which an event is
8 being delivered;

9 wherein said second level structure indicator includes information
10 regarding said at least one participant associated with said corresponding lower
11 level participant manager, and

12 wherein said first level structure indicator includes aggregate information
13 regarding said lower level participant managers.

1 47. A system for multicasting an event to a plurality of participants
2 comprising:

3 a director having a multicast address associated therewith for delivering the
4 event to the plurality of participants;

5 a plurality of participant managers installed within a network
6 communication system and logically connected amongst themselves and to said
7 director thereby forming a hierarchy organized on a geographic basis; and

8 a turnstile installed at and associated with each of the plurality of
9 participants, each turnstile logically connected to one of said plurality of
10 participant managers in said hierarchy that corresponds to a geographic location of
11 said associated participant, said turnstile requiring a ticket for said associated
12 participant to access the event,

13 wherein said director allocates a non-zero number of tickets to a first
14 participant manager in said hierarchy and allocates zero tickets to a second
15 participant manager in said hierarchy thereby restricting access to the event to
16 some of the plurality of participants.

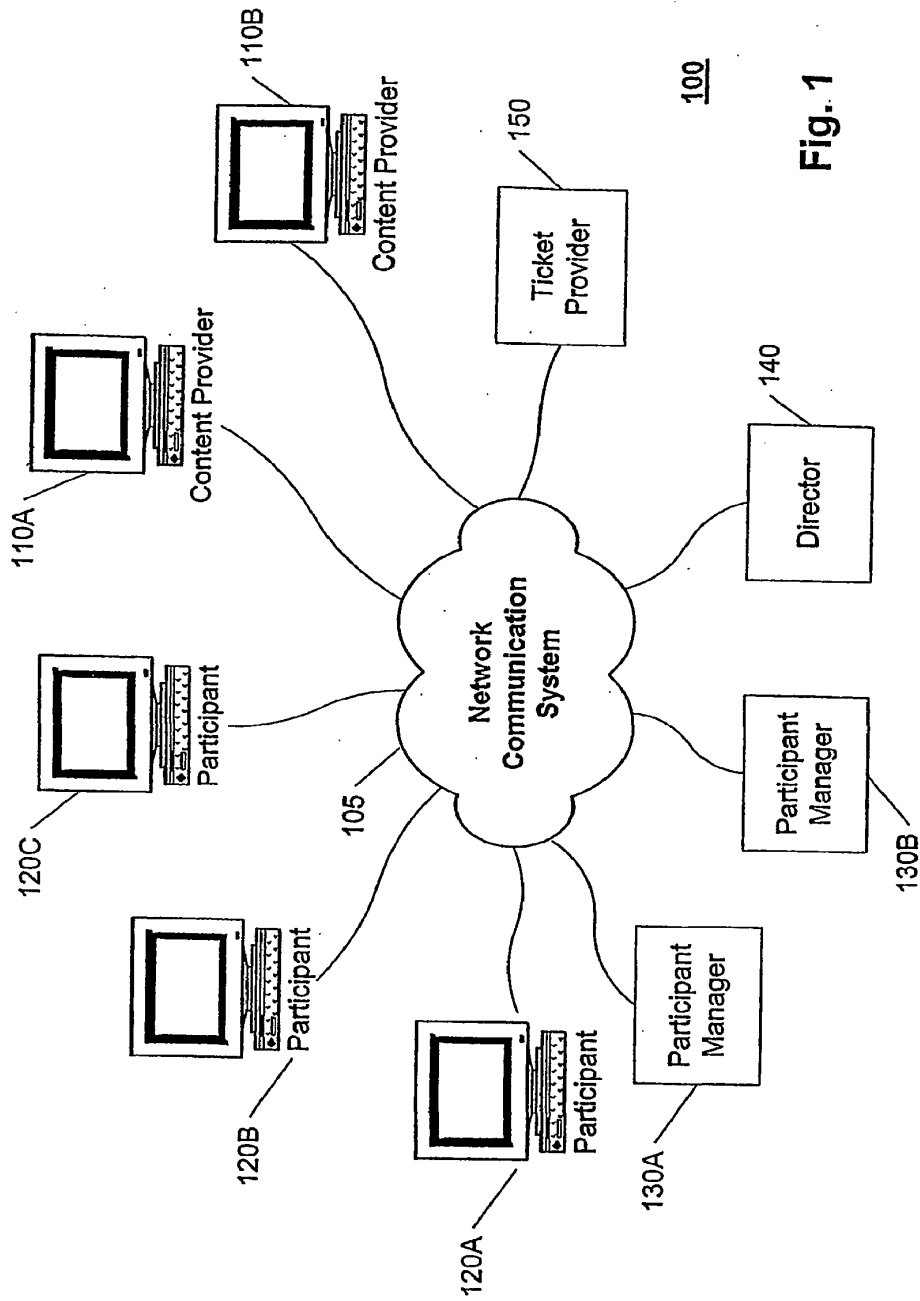

Fig. 1

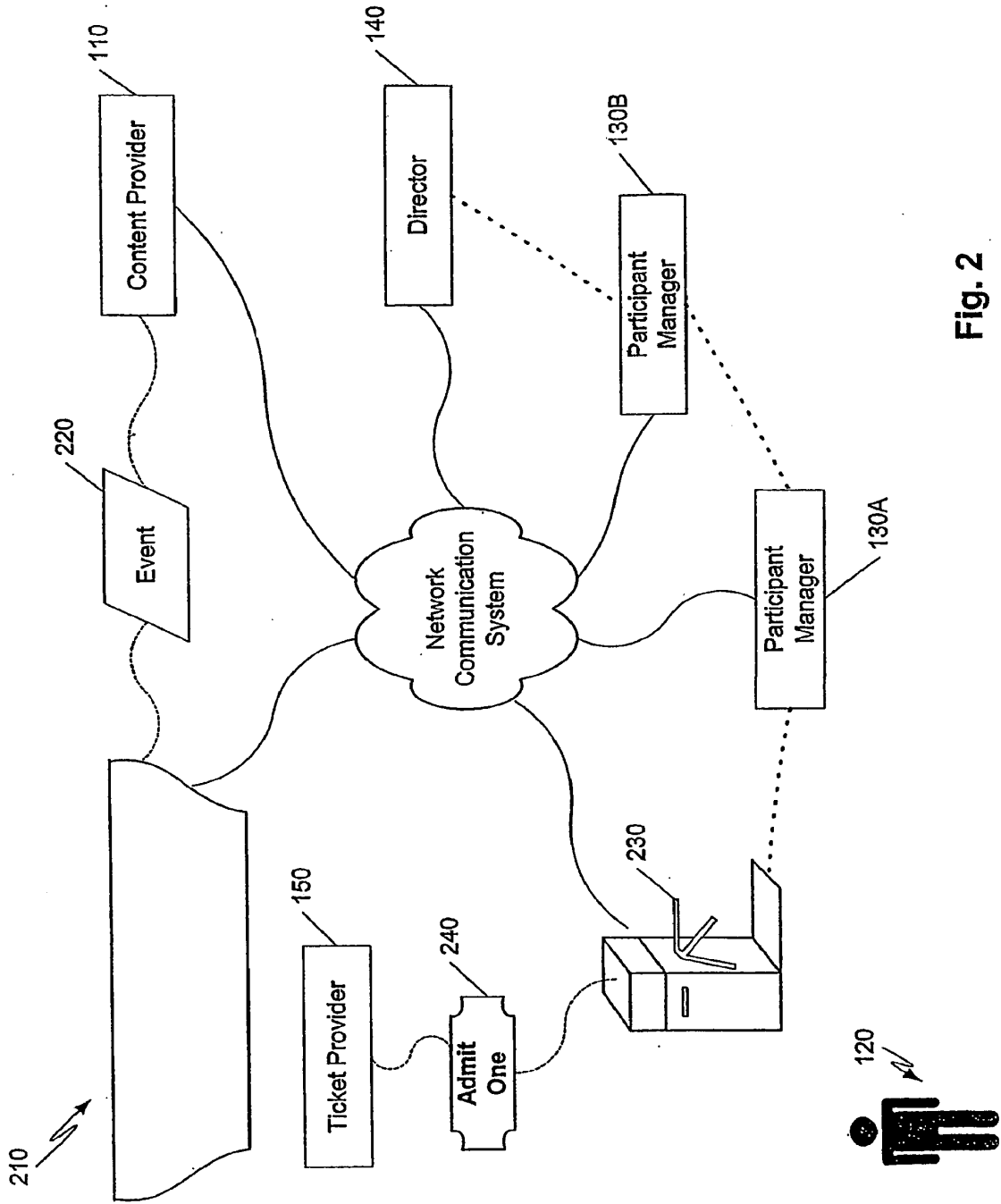

Fig. 2

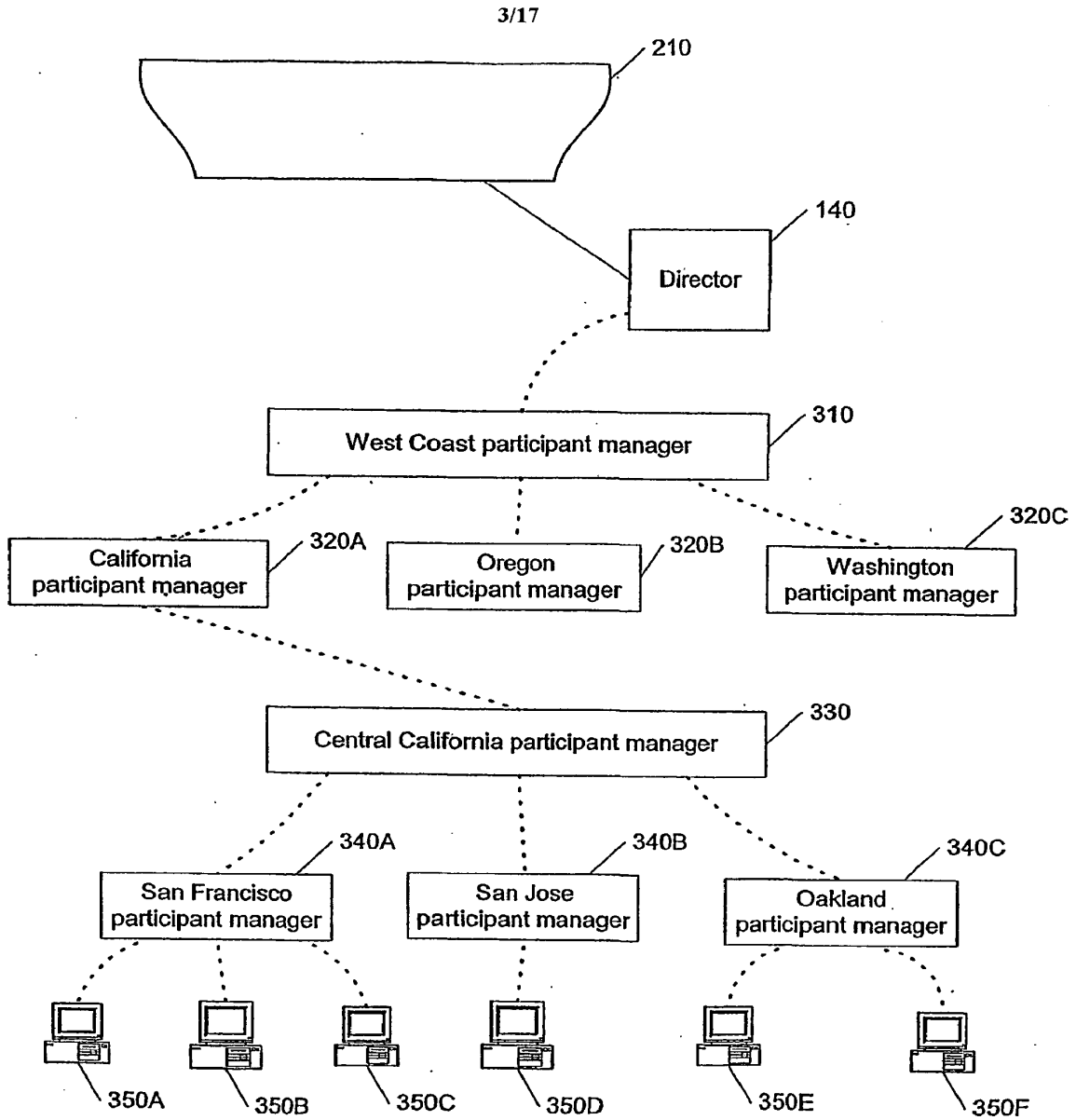

Fig. 3



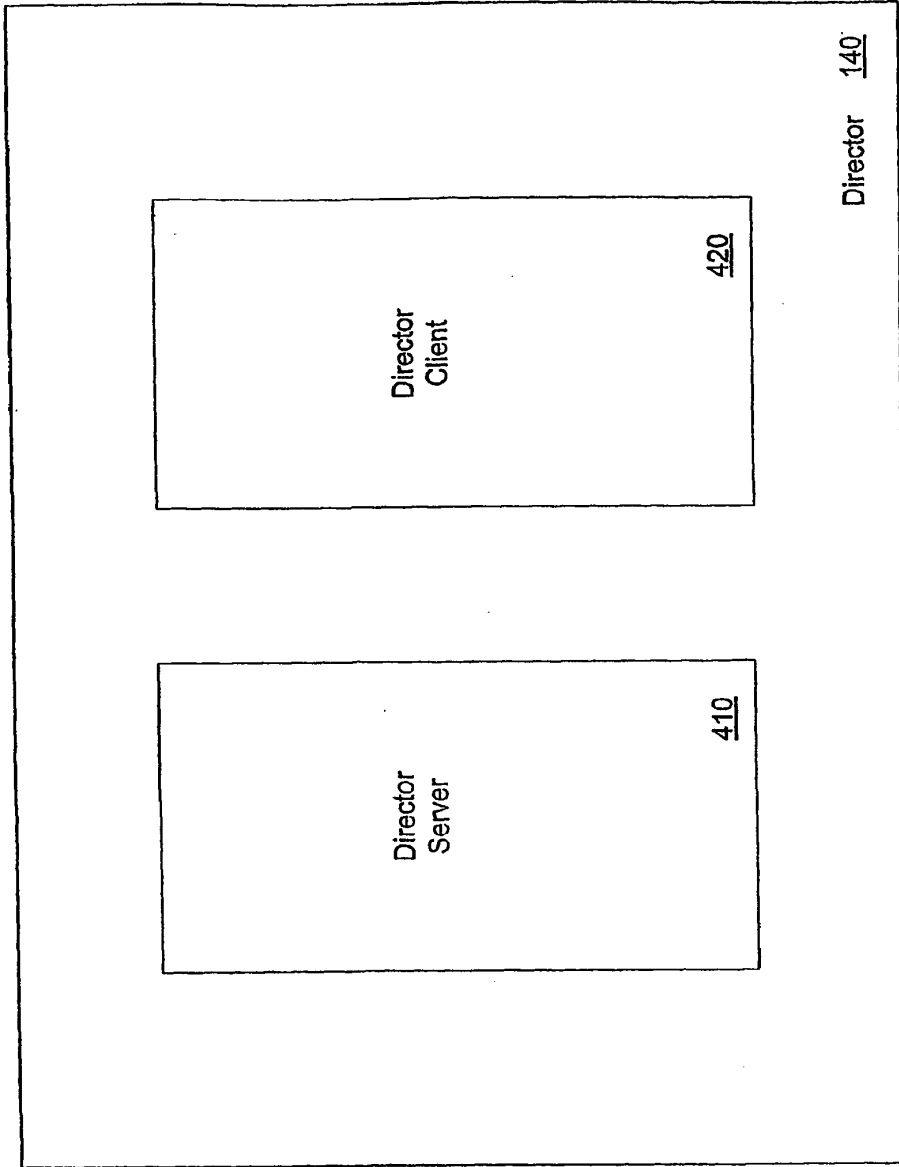

Fig. 4

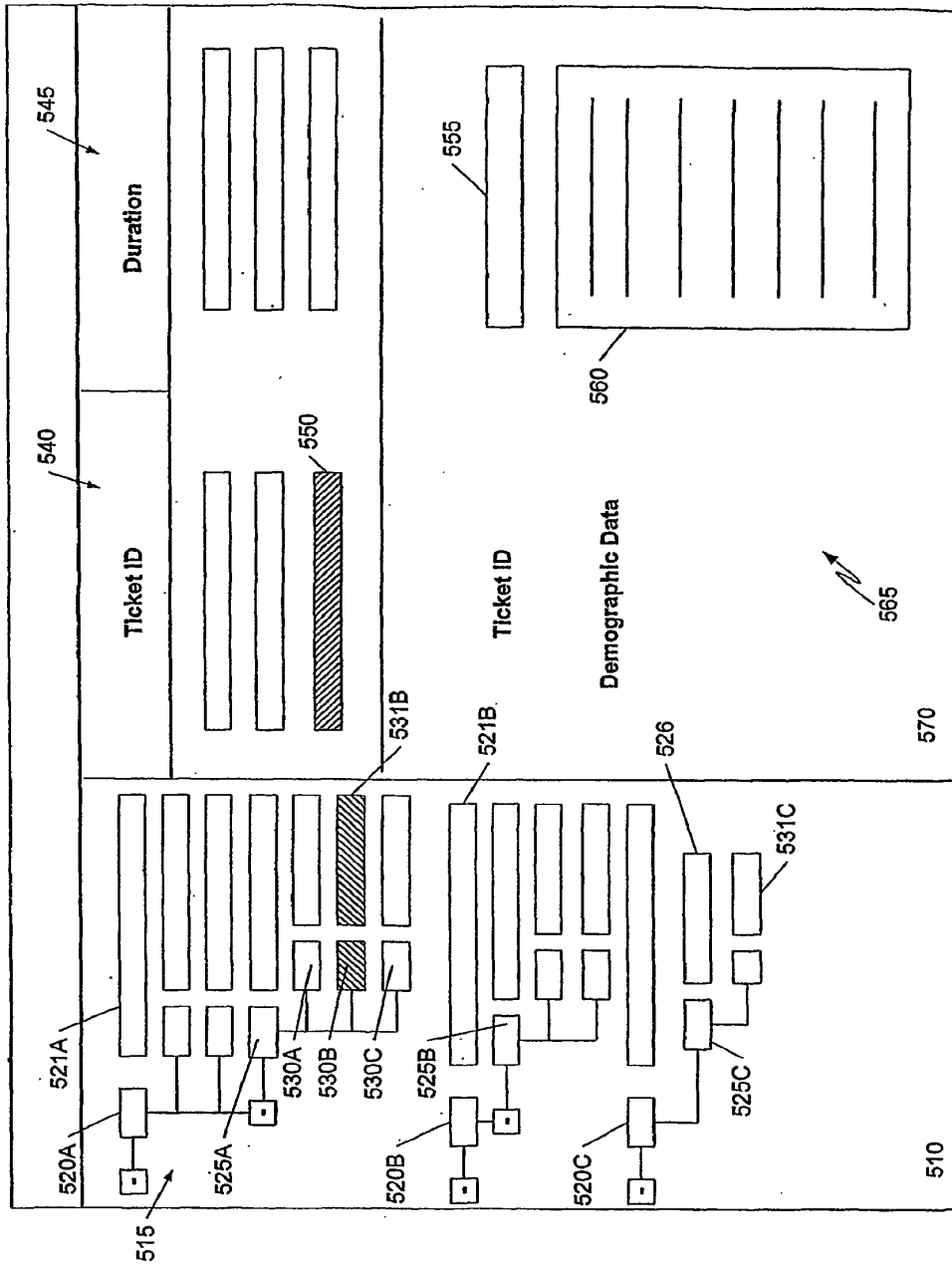
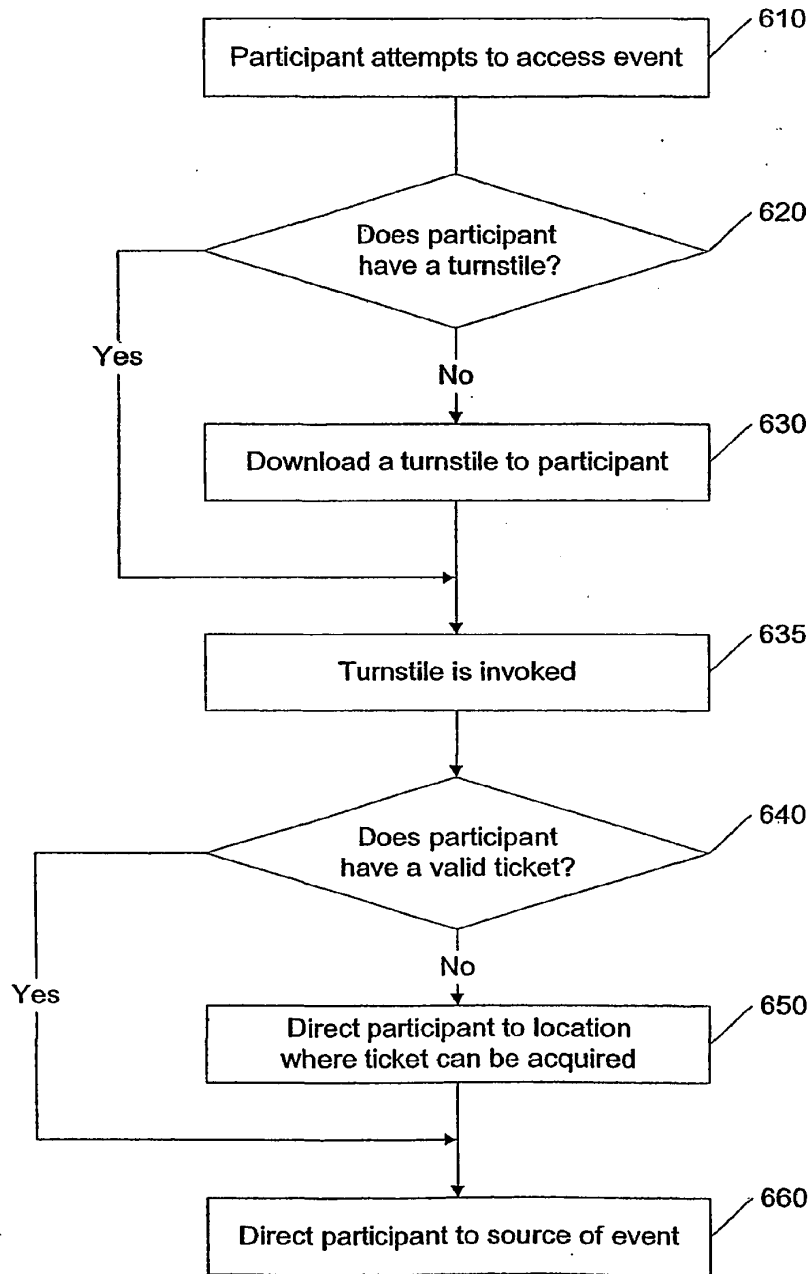

Fig. 5

500



600

Fig. 6

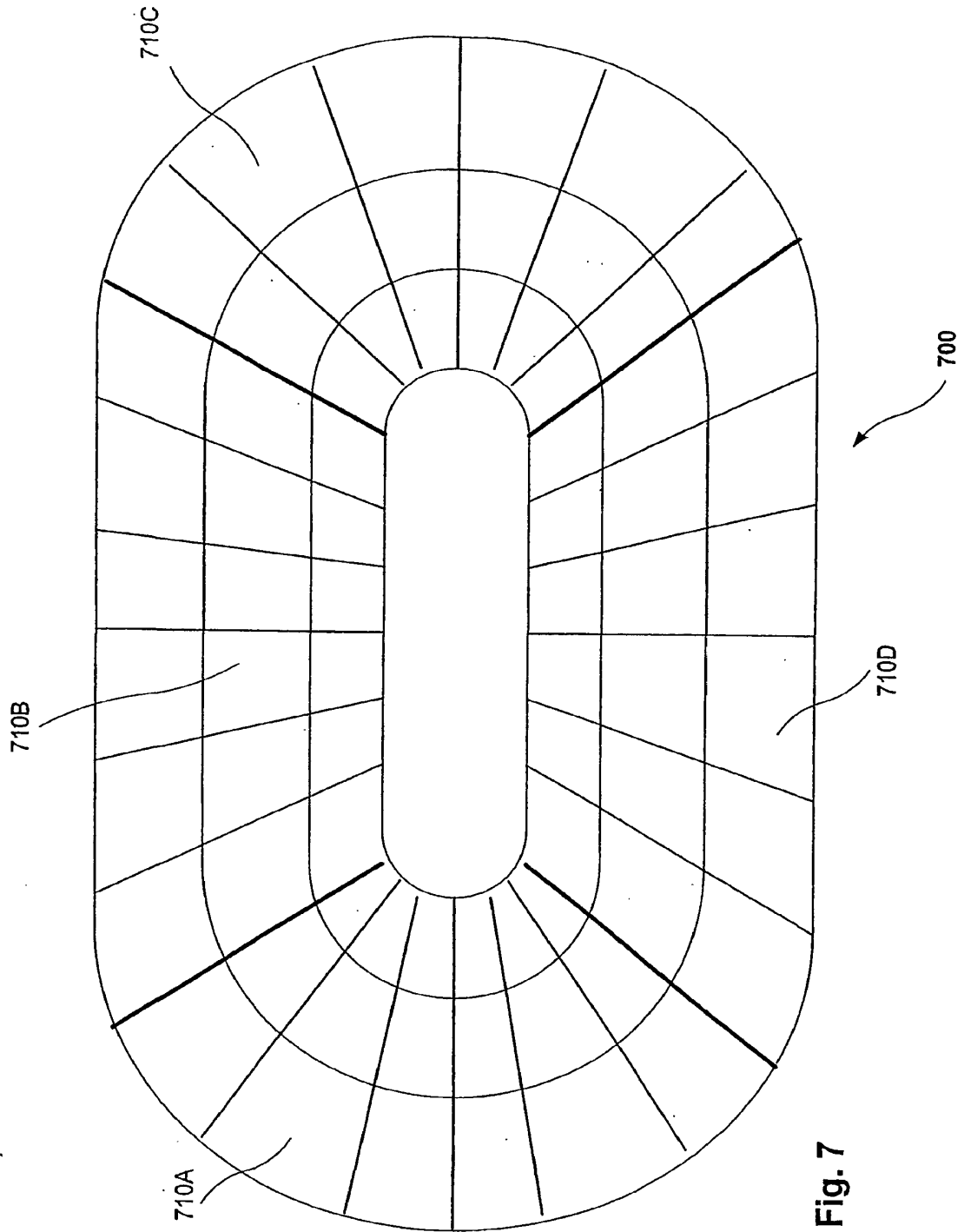
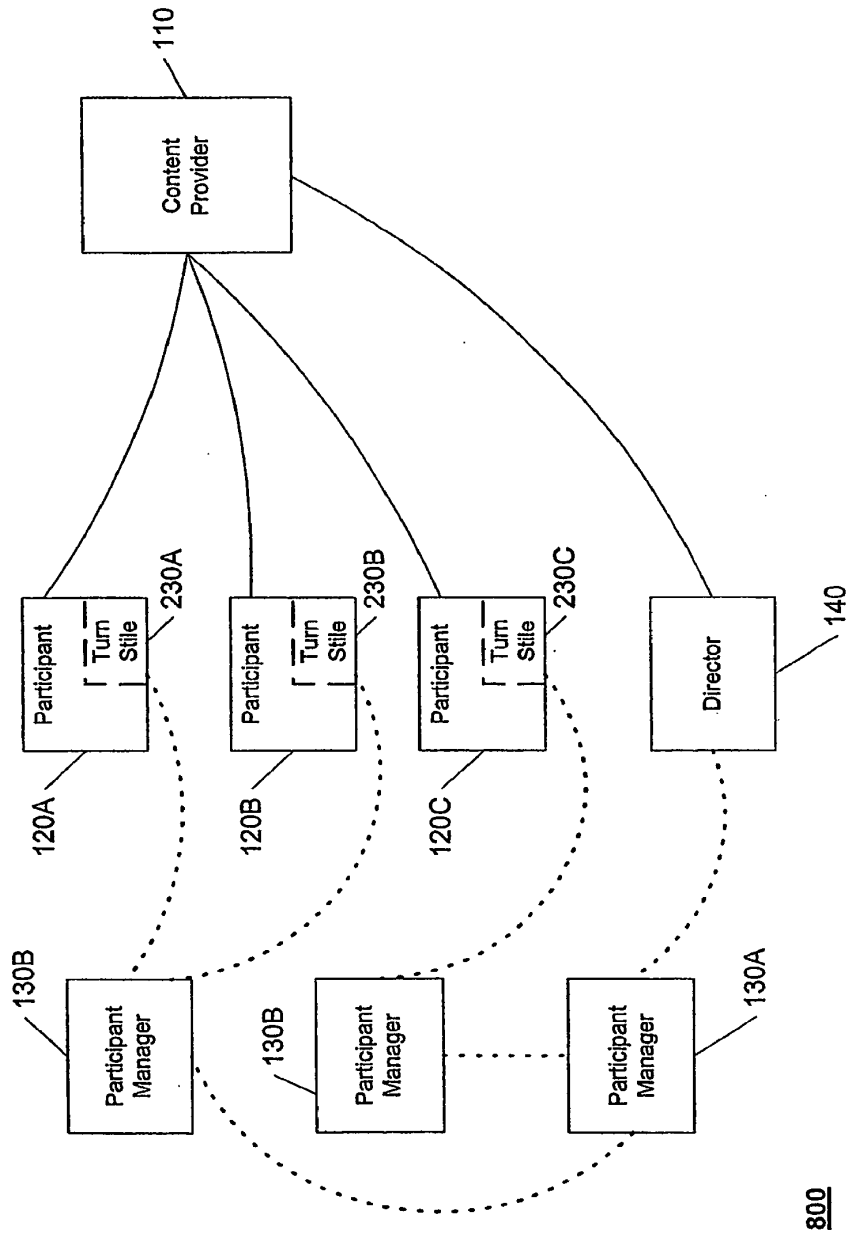

Fig. 7



800

Fig. 8

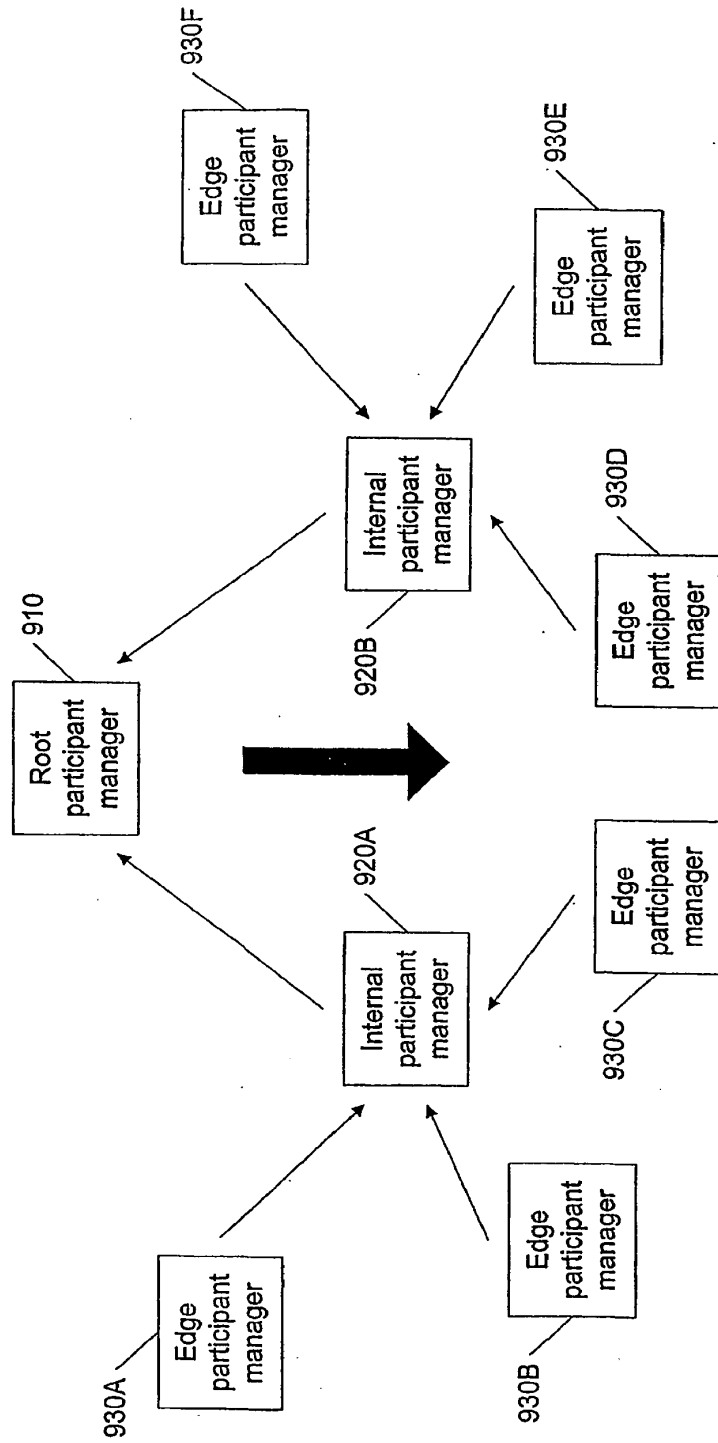

Fig. 9

900

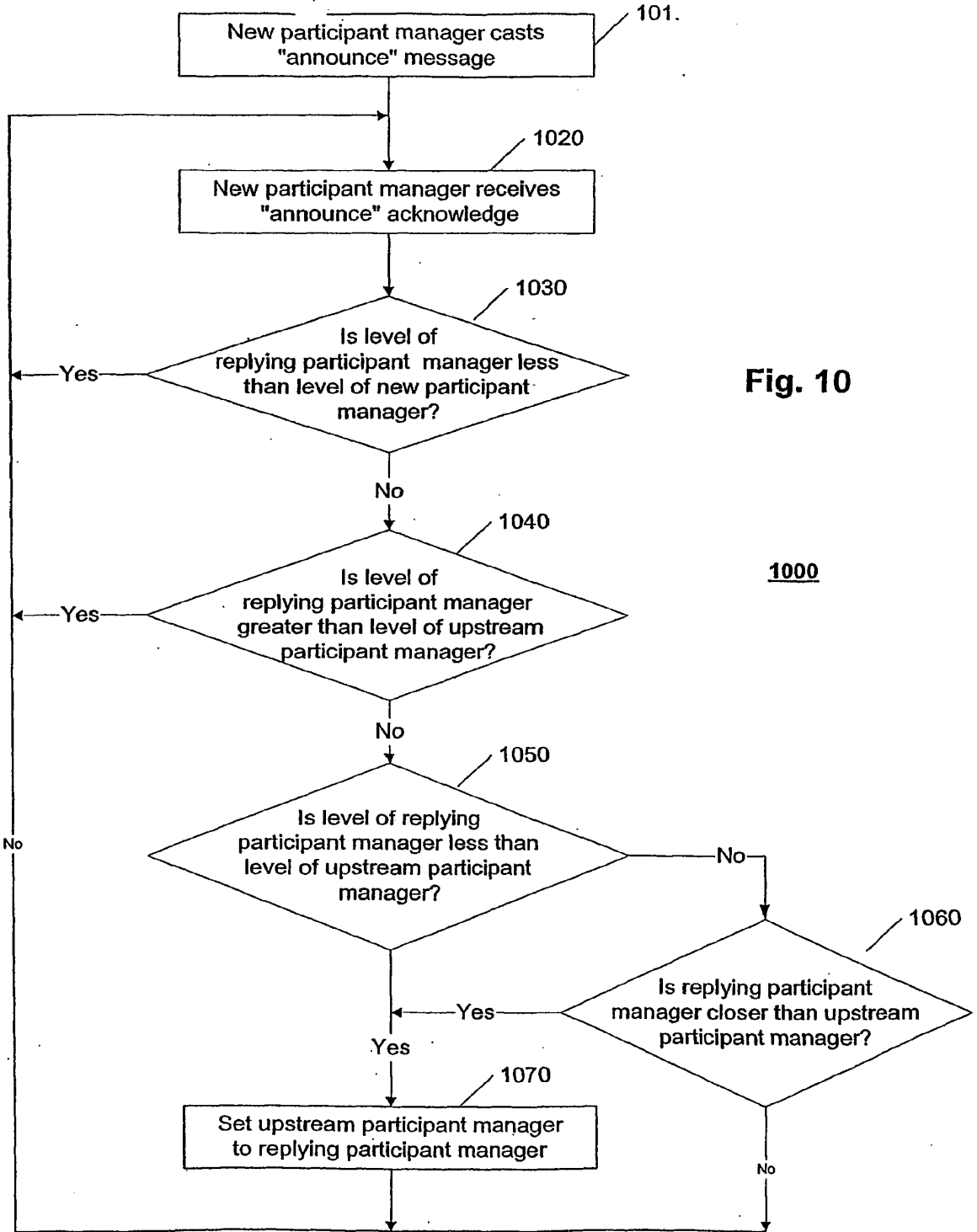
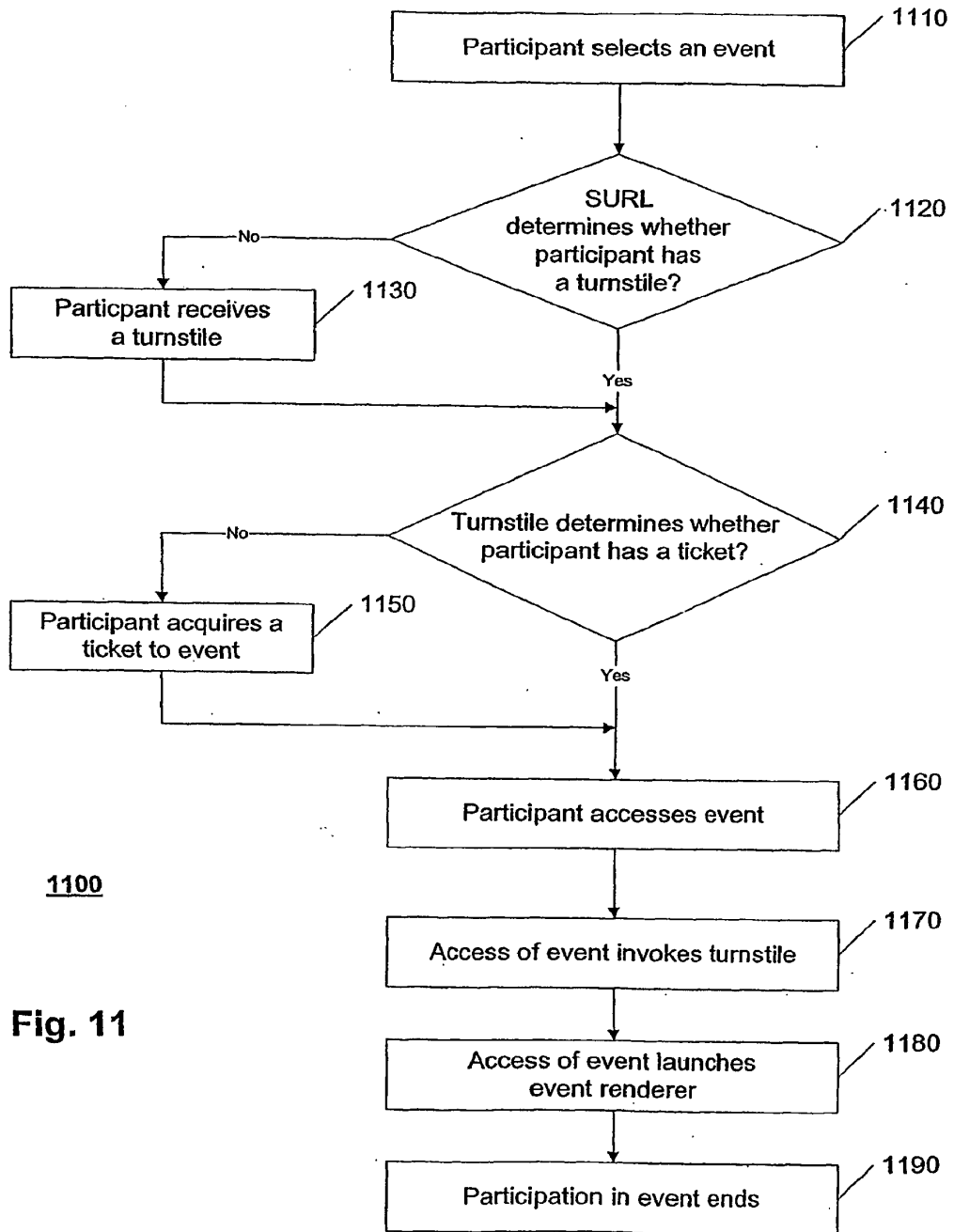

Fig. 10

1000



1100

Fig. 11

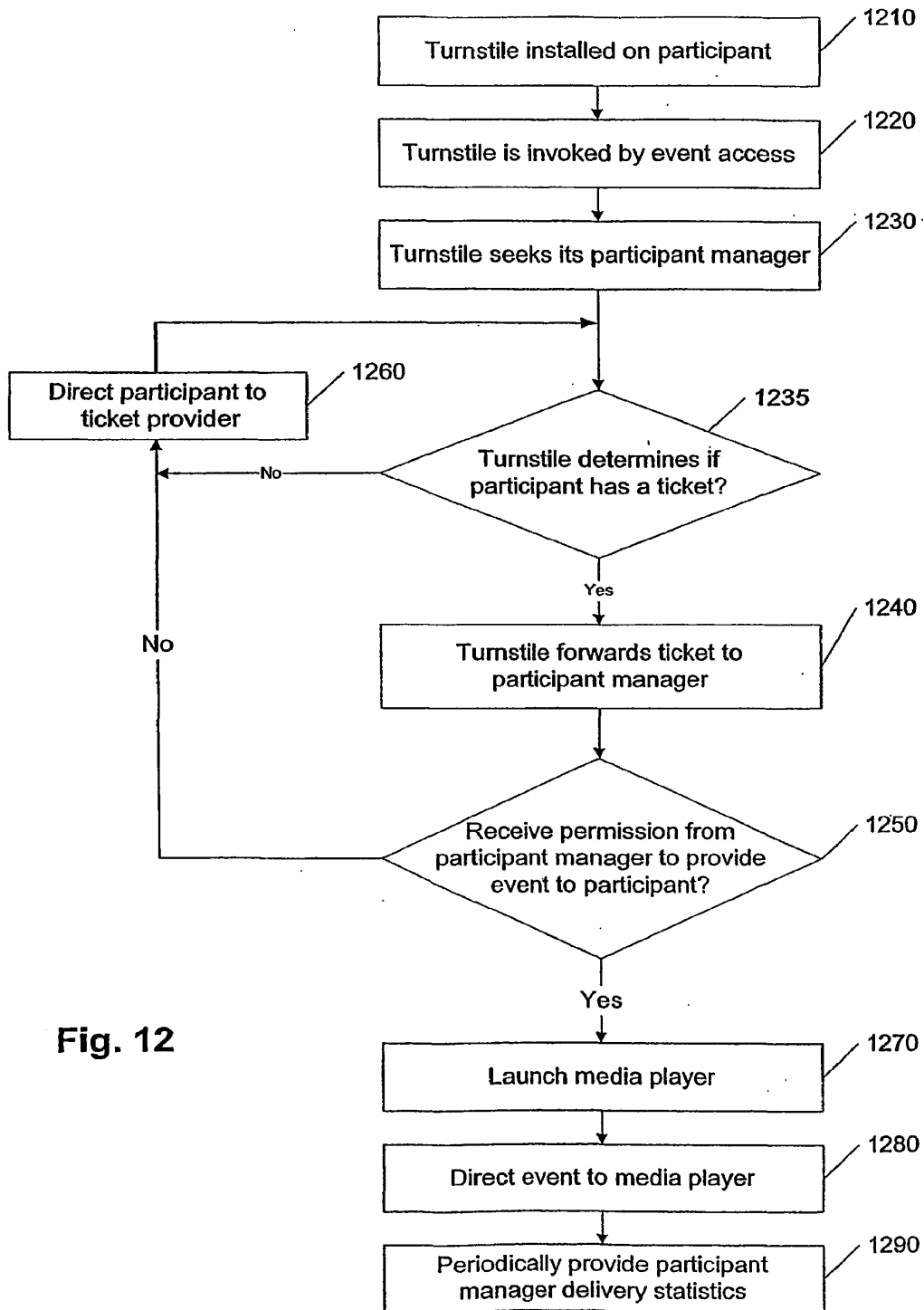

Fig. 12

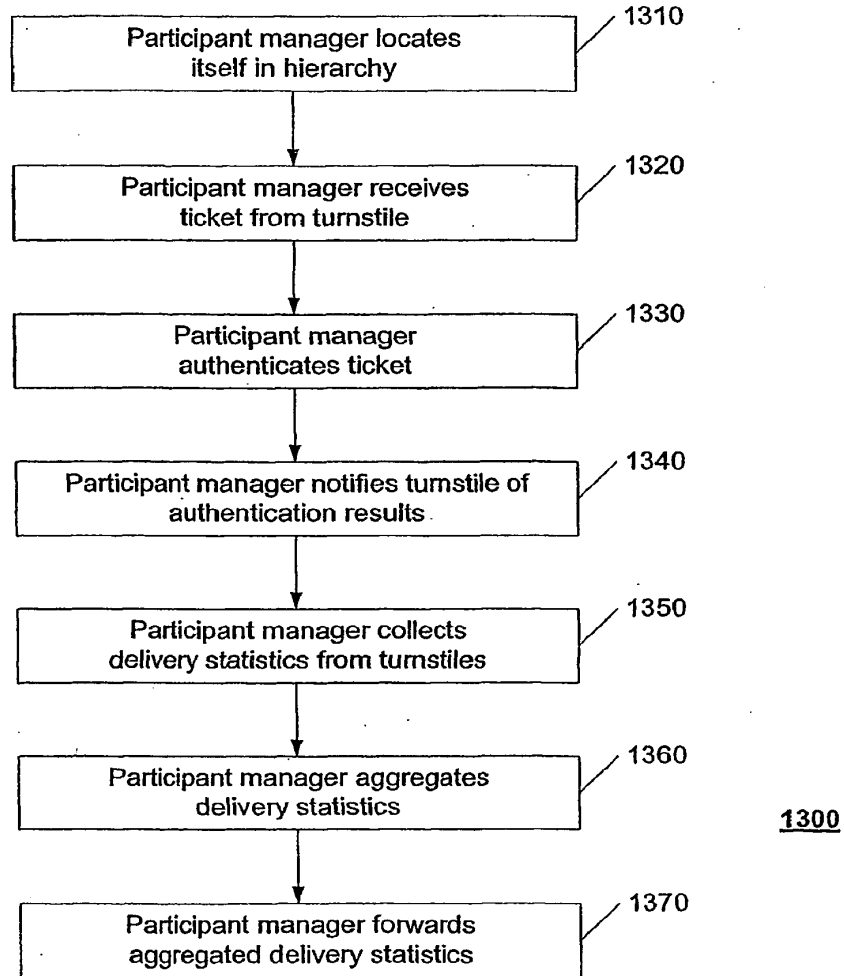
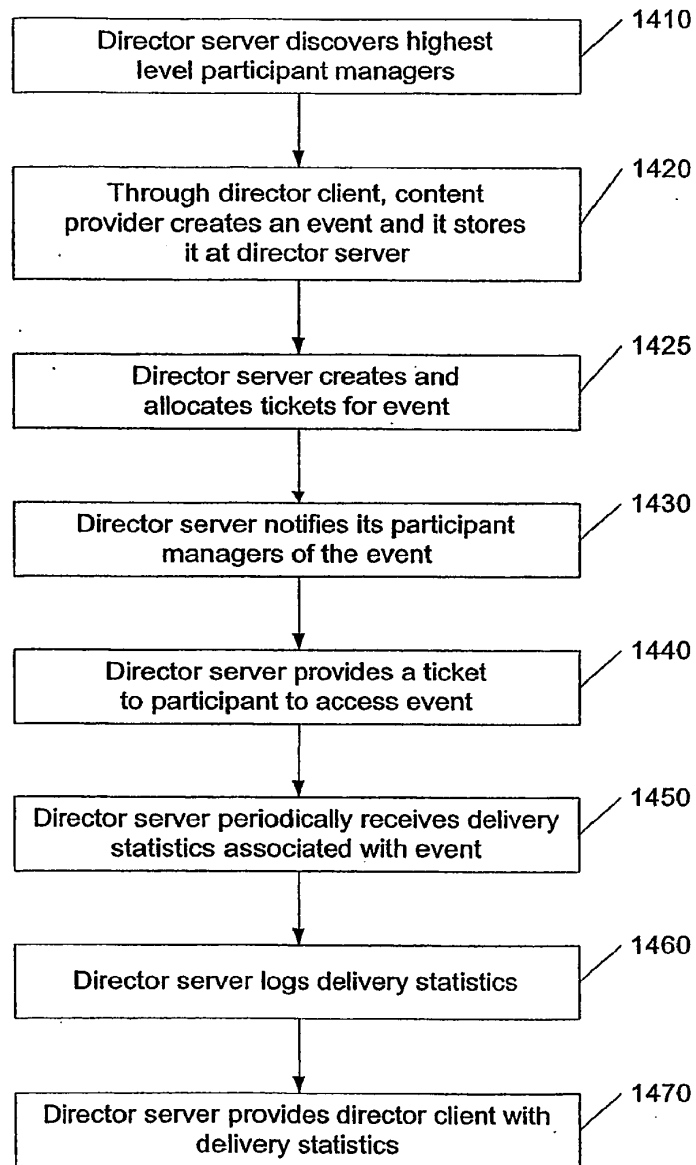

Fig. 13



1400

Fig. 14

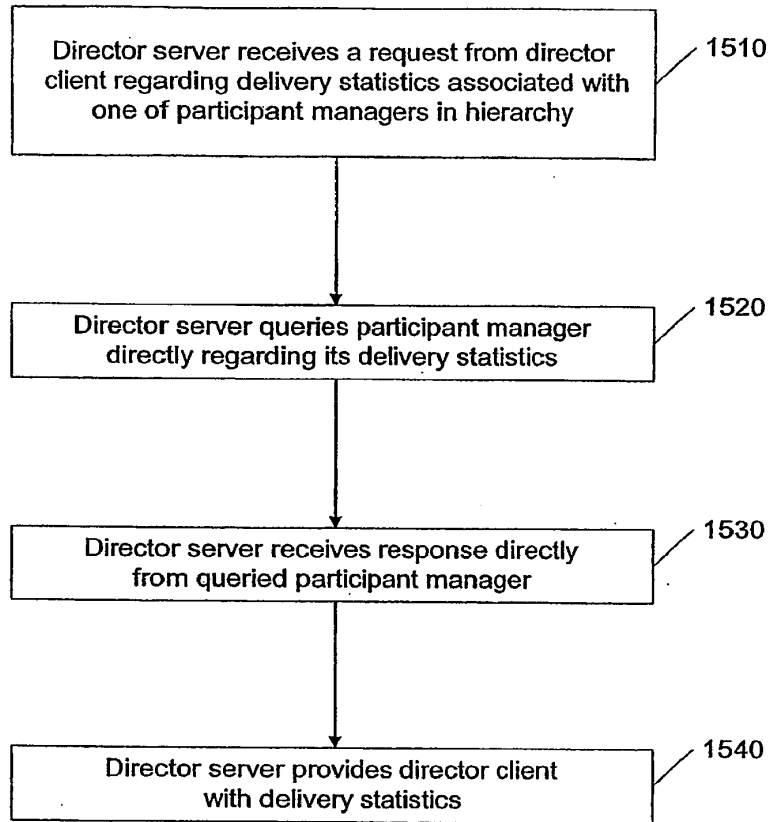
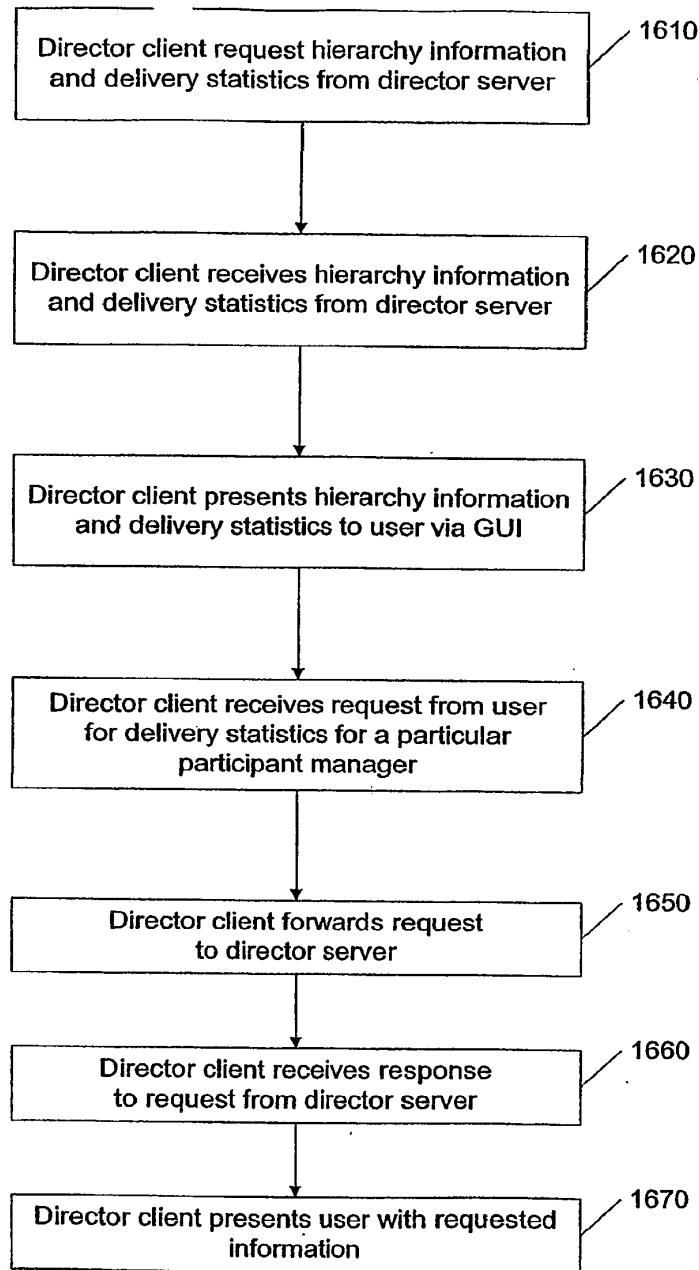
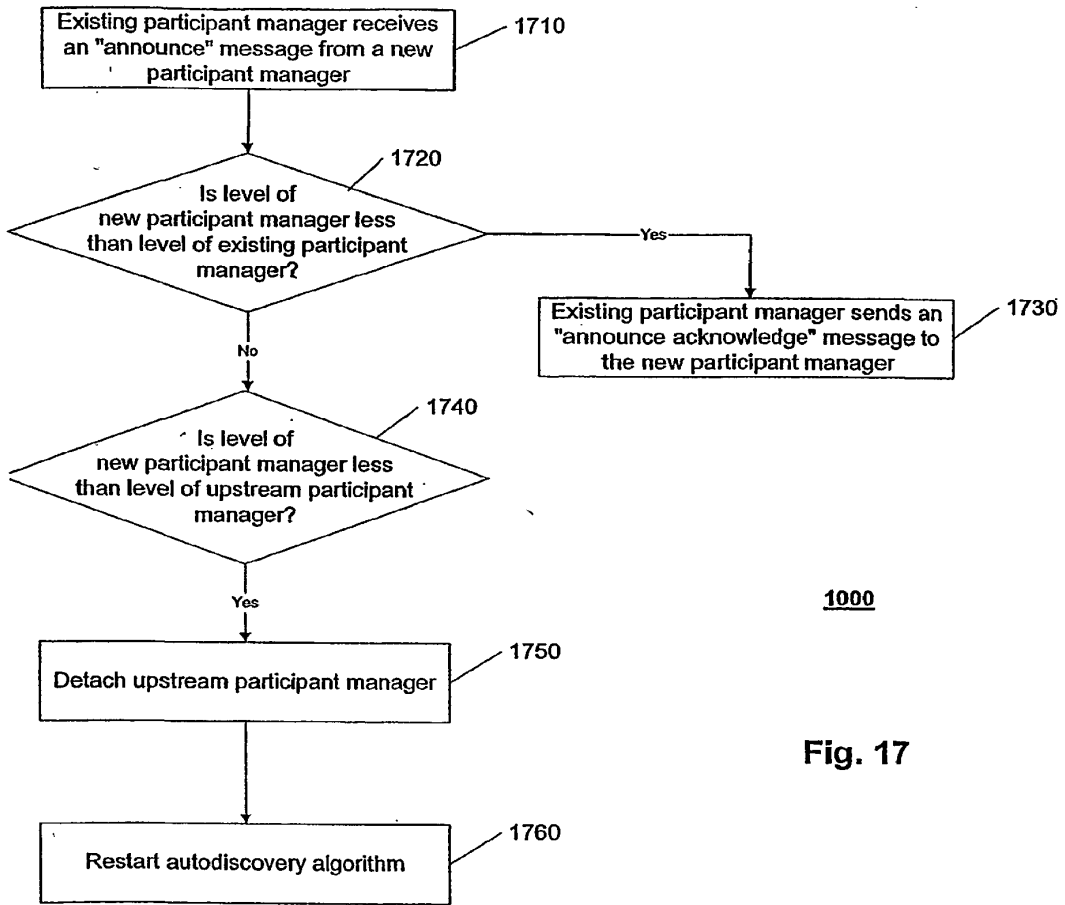

Fig. 15



1600

Fig. 16



(12) INTERNATIONAL APPLICATION PUBLISHED UNDER THE PATENT COOPERATION TREATY (PCT)

(19) World Intellectual Property Organization
International Bureau



(43) International Publication Date
22 November 2001 (22.11.2001)

PCT

(10) International Publication Number
WO 01/89150 A3

(51) International Patent Classification⁷: H04L 12/18, G06F 17/60, H04L 29/06, G06F 17/30

(21) International Application Number: PCT/US01/16156

(22) International Filing Date: 18 May 2001 (18.05.2001)

(25) Filing Language: English

(26) Publication Language: English

(30) Priority Data: 09/572,853 18 May 2000 (18.05.2000) US

(71) Applicant: RELIACAST, INC. [US/US]; Suite #1, 397 Herndon Parkway, Herndon, VA 20170 (US).

(72) Inventors: MCNABB, James: Apartment 402, 1739 Port Place, Reston, VA 20194 (US). BATTLE, Ben: 13606 Old Chatwood Place, Chantilly, VA 20151-3369 (US).

(74) Agents: TALBOT, Scott, C. et al.: Cooley Godward LLP, One Freedom Square, 11951 Freedom Drive, Reston, VA 20191-5601 (US).

(81) Designated States (*national*): AE, AG, AL, AM, AT, AU, AZ, BA, BB, BG, BR, BY, BZ, CA, CH, CN, CR, CU, CZ, DE, DK, DM, DZ, EE, ES, FI, GB, GD, GE, GH, GM, HR, HU, ID, IL, IN, IS, JP, KE, KG, KP, KR, KZ, LC, LK, LR, LS, LT, LU, LV, MA, MD, MG, MK, MN, MW, MX, MZ, NO, NZ, PL, PT, RO, RU, SD, SE, SG, SI, SK, SL, TJ, TM, TR, TT, TZ, UA, UG, UZ, VN, YU, ZA, ZW.

(84) Designated States (*regional*): ARIPO patent (GH, GM, KE, LS, MW, MZ, SD, SL, SZ, TZ, UG, ZW), Eurasian patent (AM, AZ, BY, KG, KZ, MD, RU, TJ, TM), European patent (AT, BE, CH, CY, DE, DK, ES, FI, FR, GB, GR, IE, IT, LU, MC, NL, PT, SE, TR), OAPI patent (BF, BJ, CF, CG, CI, CM, GA, GN, GW, ML, MR, NE, SN, TD, TG).

Published:

- with international search report
- before the expiration of the time limit for amending the claims and to be republished in the event of receipt of amendments

(88) Date of publication of the international search report:
2 May 2002

[Continued on next page]

(54) Title: SYSTEM AND METHOD FOR MULTICASTING DATA

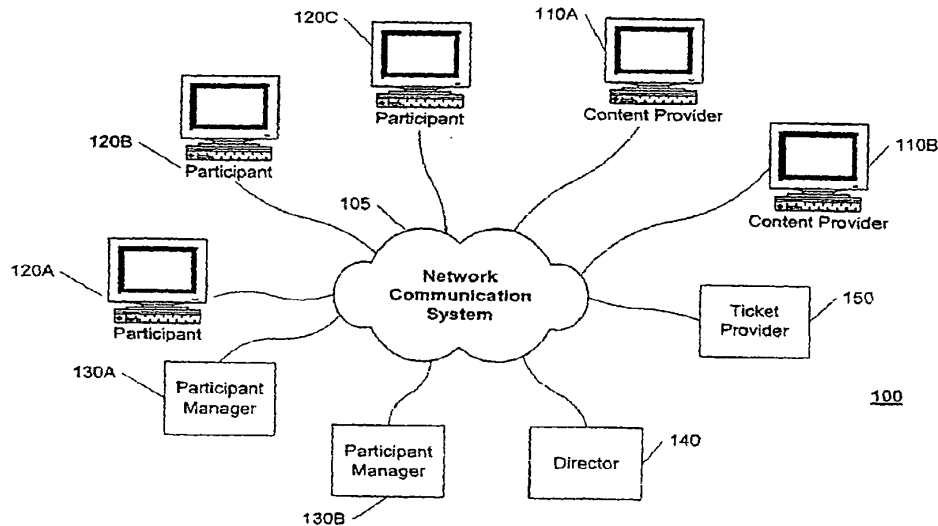

(57) Abstract: A system and method for multicasting data over a network includes a director, a hierarchy of participant managers, and a turnstile installed at each participant to which the data is multicasted. Content providers provide information associated with an event to the director. The director oversees the delivery of the event to a participant. In particular, the director allocates and provides a ticket to the participant. The participant acquires the ticket, either directly or indirectly from the director. When the participant attempts to access the event, the locally installed turnstile authenticates the ticket thereby gating access to the event. The turnstile also provides delivery statistics associated with the delivery of the event to the director via the hierarchy of participant managers.

WO 01/89150 A3



For two-letter codes and other abbreviations, refer to the "Guidance Notes on Codes and Abbreviations" appearing at the beginning of each regular issue of the PCT Gazette.

INTERNATIONAL SEARCH REPORT

International: Application No
PCT/US 01/16156

A. CLASSIFICATION OF SUBJECT MATTER
IPC 7 H04L12/18 G06F17/60 H04L29/06 G06F17/30

According to International Patent Classification (IPC) or to both national classification and IPC

B. FIELDS SEARCHED
Minimum documentation searched (classification system followed by classification symbols)
IPC 7 H04L G06F H04N

Documentation searched other than minimum documentation to the extent that such documents are included in the fields searched

Electronic data base consulted during the international search (name of data base and, where practical, search terms used)
EPO-Internal, WPI Data, PAJ, INSPEC, IBM-TDB, COMPENDEX

C. DOCUMENTS CONSIDERED TO BE RELEVANT

Category *	Citation of document, with indication, where appropriate, of the relevant passages	Relevant to claim No.
A	EP 0 575 279 A (INTERNATIONAL BUSINESS MACHINES CORPORATION) 22 December 1993 (1993-12-22) column 2, line 35 -column 3, line 17 column 4, line 35 -column 5, line 6 column 8, line 37 -column 9, line 52 -----	1-47

Further documents are listed in the continuation of box C.

Patent family members are listed in annex.

* Special categories of cited documents:

- *A* document defining the general state of the art which is not considered to be of particular relevance
- *E* earlier document but published on or after the international filing date
- *L* document which may throw doubts on priority claim(s) or which is cited to establish the publication date of another citation or other special reason (as specified)
- *O* document referring to an oral disclosure, use, exhibition or other means
- *P* document published prior to the international filing date but later than the priority date claimed

- *T* later document published after the international filing date or priority date and not in conflict with the application but cited to understand the principle or theory underlying the invention
- *X* document of particular relevance; the claimed invention cannot be considered novel or cannot be considered to involve an inventive step when the document is taken alone
- *Y* document of particular relevance; the claimed invention cannot be considered to involve an inventive step when the document is combined with one or more other such documents, such combination being obvious to a person skilled in the art.
- *G* document member of the same patent family

Date of the actual completion of the international search
7 March 2002

Date of mailing of the international search report
15/03/2002

Name and mailing address of the ISA
European Patent Office, P.B. 5618 Patentlaan 2
NL - 2280 HV Rijswijk
Tel. (+31-70) 340-2040, Tx. 31 651 epo nl,
Fax: (+31-70) 340-3016

Authorized officer
Ströbeck, A.

INTERNATIONAL SEARCH REPORT

Information on patent family members

Internati	Application No
PCT/US 01/16156	

Patent document cited in search report	Publication date	Patent family member(s)	Publication date
EP 0575279 A	22-12-1993	AU 3839093 A	23-12-1993
		CA 2094410 A1	19-12-1993
		CN 1081042 A ,B	19-01-1994
		EP 0575279 A2	22-12-1993
		JP 2503189 B2	05-06-1996
		JP 6152593 A	31-05-1994
		KR 9614979 B1	23-10-1996
		US 5634011 A	27-05-1997

Form PCT/ISA/210 (patent family annex) (July 1992)

(12) INTERNATIONAL APPLICATION PUBLISHED UNDER THE PATENT COOPERATION TREATY (PCT)

(19) World Intellectual Property Organization
International Bureau



(43) International Publication Date
28 August 2003 (28.08.2003)

PCT

(10) International Publication Number
WO 03/071392 A2

- (51) International Patent Classification⁷: G06F (72) Inventors: XU, Lin; Pyrypolku 11, FIN-33880 Lempälää (FI). LEINONEN, Jarno; Kisakentänkatu 24 B 13, FIN-33230 Tampere (FI).
- (21) International Application Number: PCT/US03/04986
- (22) International Filing Date: 20 February 2003 (20.02.2003) (74) Agent: WASZKIEWICZ, Kenneth, P.; c/o Morgan & Finnegan, LLP, 345 Park Avenue, New York, NY 10154 (US).
- (25) Filing Language: English (81) Designated State (national): CN.
- (26) Publication Language: English
- (30) Priority Data: 10/077,780 20 February 2002 (20.02.2002) US Published: — without international search report and to be republished upon receipt of that report
- (71) Applicants: NOKIA CORPORATION [FI/FI]; Keilalahdentie 4, FIN-FIN-02150 Espoo (FI). NOKIA INC. [US/US]; 6000 Connection Drive, Irving, TX 75039 (US). For two-letter codes and other abbreviations, refer to the "Guidance Notes on Codes and Abbreviations" appearing at the beginning of each regular issue of the PCT Gazette.



WO 03/071392 A2

(54) Title: CHARGING MECHANISM FOR MULTICASTING

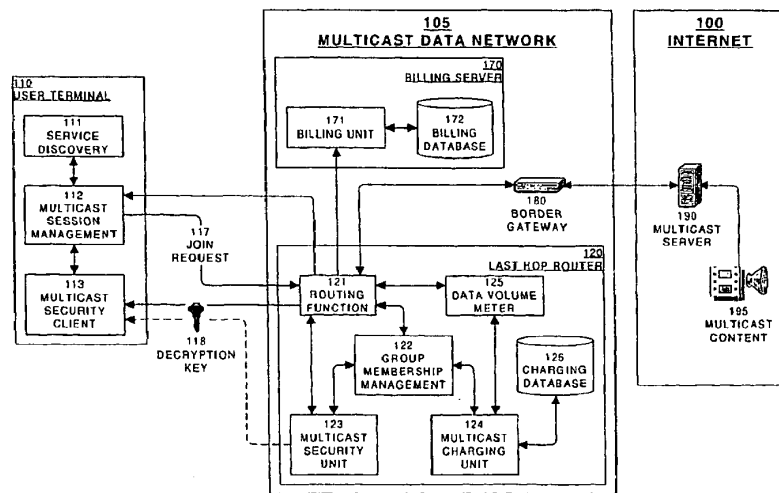

(57) Abstract: An apparatus for calculating a cost of receiving multicast data from a multicast session. A multicast network includes at least one multicast service, each multicast service including at least one multicast session. The apparatus receives a request to establish a connection to the multicast session, stores a start time for the connection and an end time for the connection and, after termination of the connection, calculates the cost of receiving the multicast data. The apparatus can receive a subsequent request to extend the connection, the subsequent request specifying a new end time for the connection, and store the new end time for the connection. Alternatively, the apparatus can receive a subsequent request to terminate the connection, the subsequent request specifying a new end time that precedes the end time for the connection, and store the new end time for the connection.

CHARGING MECHANISM FOR MULTICASTING

This international application claims priority to U.S. Application Serial No. 10/077,780, filed February 20, 2002, and which is incorporated herein by reference.

CROSS-REFERENCE TO A RELATED APPLICATION

5 This application for letters patent is related to and incorporates by reference United States patent application serial number TBD titled "A System and Method for Efficient Distribution of Multicastable Services" and filed in the United States Patent and Trademark Office on December 6, 2001.

FIELD OF THE INVENTION

10 The invention disclosed herein is a method, system, and computer program product for calculating a cost of receiving multicast data from a multicast session. In particular, the method, system, and computer program product calculates the cost of receiving multicast data based on either the elapsed time that a user connects to a multicast session, or the volume of data received at a destination during the connection period.

15 BACKGROUND OF THE INVENTION

A one-to-many or many-to-many Internet Protocol (IP) application involves one or multiple sources sending IP messages to multiple receivers. Exemplary applications include the transmission of corporate messages to employees, communication of stock quotes to brokers, video and audio conferencing for remote meetings and telecommuting, and replicating databases and web site information. The IP multicast protocol efficiently supports one-to-many or many-to-many applications by allowing a source to send a single copy of a message to any recipient who explicitly requests to receive the message. IP multicast is more efficient than a point-to-point unicast protocol that requires the source to send an individual copy of a message to each requester thereby limiting the number of
25 receivers by the bandwidth available to the sender. IP multicast is also more efficient than a

broadcast protocol that sends one copy of a message to every node on the network even though many of the nodes may not want the message and the broadcast protocol is limited to a single subnet. Furthermore, the IP multicast protocol is applicable not only to wired networks, but also wireless networks. For example, in wireless network, link level
5 multicasting allows several terminals to receive data sent over a single air interface.

IP Multicast is a receiver-based protocol. A receiver subscribes to a multicast session group by sending a join message to the multicast session group. Since the network infrastructure delivers the traffic to each member of the multicast session group, the sender does not need to maintain a list of receivers. The advantage is that only one copy of a
10 multicast message passes over any link in the network. In addition, IP Multicast only creates a copy of the message when the paths diverge at a router. Thus, IP multicast yields many performance improvements and conserves bandwidth throughout the system.

IP multicast is an extension to the standard IP network-level protocol. RFC 1112, titled "Host Extensions for IP Multicasting" and authored by Steve Deering in 1989,
15 describes IP multicasting as "the transmission of an IP datagram to a 'host group', a set of zero or more hosts identified by a single IP destination address. IP multicasting delivers a multicast datagram to every member of the destination host group with the same 'best-efforts' reliability as regular unicast IP datagrams. The membership of a host group is dynamic; that is, hosts may join and leave groups at any time. There is no restriction on the
20 location or number of members in a host group. A host may be a member of more than one group at a time." In addition, at the application level, a single group address may have multiple data streams on different port numbers, on different sockets, in one or more applications. Multiple applications may share a single group address on a host.

Multicast communications to establish host membership in a multicast group (e.g., a
25 join message) utilize a standard, such as the Internet Group Management Protocol (IGMP), that supports multicast communication at the Open System Interconnection (OSI) data link layer (layer 2). W. Fenner, Internet Group Management Protocol, Version 2, Request for Comments (RFC) 2236, November, 1997, describe IGMP.

In a shared transport media network, encryption takes place at the Open Systems Initiative (OSI) link level (level 2) to prevent an unintended user on the same point-to-multipoint link to get the multicast packets. Alternatively, Internet Protocol security (IPsec) and tunneling can achieve the same result. In addition, in a shared transport network, it is
5 difficult for a provider to determine a total charge to associate with a multicast service between a source and a user because the total charge comprises a content charge and a delivery charge. The source determines the fee associated with the content charge based on the copyright of the content, the volume of data, or a digital right management (DRM) solution. In contrast, the resources consumed during the delivery of the content to a user
10 such as a content provider dictate the delivery charge. In a wireless network, for example, the resources consumed may include wireless radio resources. The content provider is the owner of the multicast data source, however the actual data may be obtained from a third party who owns the copyright to the content.

The content charge and the delivery charge also differ because the content charge
15 accrues against the user and the delivery charge can accrue against either the content provider or the user. If the delivery charge accrues against the content provider for sending the content over a physical network, the accrual of the charge can be on a program basis, a data volume basis, or a time basis. Accrual of the delivery charge against the content provider is suitable for delivering content such as an advertisement because the content delivery benefits
20 the content. The disadvantage, however, is that accrual of the delivery charge against the content provider requires a service agreement between the content provider and the network operator. Thus, when the delivery charge accrues against the content provider, it is not possible to charge for delivery of multicast services originating from any content provider on Internet. If the delivery charge accrues against the user for receiving the content over a
25 physical network, it is difficult to track the volume of data that the user receives. Thus, only two types of charging mechanisms are possible, flat rate charging and program or file based charging. Flat rate charging requires the user to periodically pay a fixed price for using the service. Program or file based charging requires the user to pay a fee for each request to receive a program or file. In response to the payment, the user receives an encryption key

that will allow access to the program or file. The program or file can include a software application, audio/video file, or graphic image. The encryption scheme can include link level encryption or IPsec.

5 Sophisticated and cost-effective charging mechanisms, such as time based charging
and data volume based charging, have taken the place of flat rate charging and program or
file based charging mechanisms. A charging scheme based on connection time will calculate
a fee for a service based on the amount of time that a user connects to the service. For
example, if a network operator determines that the rate for using a video service is \$5.00 per
hour, a user connecting to the video service to view a movie for thirty-minutes accrues a fee
10 of \$2.50. A charging scheme based on the volume of data will calculate a fee for a service
based on the volume of data that a user receives from the service. For example, if a network
operator determines that the rate for using a video service is \$0.25 per Megabyte of data
received, the fee for a user to use the video service to view a movie consisting of 25
Megabytes is \$6.25.

15 Currently, time based charging and data volume based charging mechanisms are not
available for IP multicast deployed in a network with shared transport media. Since it is
difficult to determine when a user has stopped using a shared transport media service, it is
difficult for network to calculate the connection time or data volume received. For example,
user may establish a multicast connection through a digital broadcast network, but when the
20 battery in the user's terminal loses a charge, the connection is broken without any indication
of disjoining the service. Thus, the charging will continue even though the multicast service
is no longer in use. Furthermore, security is a problem because the user has the possibility to
disjoin the service, but still receives the data from the shared transport media service. This
invention disclosed here is one possible solution to establish a secure billing system for
25 multicast service in a network that is capable for link level multicasting.

Thus, there is a need for a system, method, and computer program product for
calculating a cost of receiving multicast data from a multicast session. The system, method,
and computer program product will calculate the cost of receiving multicast data based on
either the elapsed time that a user connects to a multicast session, or the volume of data

received at a destination during the connection period. The system, method, and computer program product disclosed herein establish a secure billing system for multicast services in a network that provides link level multicasting.

SUMMARY OF THE INVENTION

5 A method, system, and computer program product for calculating a cost of receiving multicast data from a multicast session. A multicast network includes at least one multicast service, each multicast service including at least one multicast session. The method, system, and computer program product receives a request to establish a connection to the multicast session, the request including a start time for the connection and an end time for the
10 connection. The method, system, and computer program product stores the start time for the connection and the end time for the connection and, after termination of the connection, calculates the cost of receiving the multicast data.

 The method, system, and computer program product can receive a subsequent request to extend the connection, the subsequent request specifying a new end time for the
15 connection, and store the new end time for the connection. Alternatively, the method, system, and computer program product can receive a subsequent request to terminate the connection, the subsequent request specifying a new end time that precedes the end time for the connection, and store the new end time for the connection.

 In one embodiment, the storing of the start time for the connection and the end time
20 for the connection is to a database.

 To calculate the cost, the method, system, and computer program product computes a charge for receiving the multicast data, stores the charge, and computes the cost by multiplying the charge by a fee for the multicast service associated with the multicast session. In one embodiment, the storing of the charge is to a database. The method, system,
25 and computer program product can compute an elapsed connection time by subtracting the start time for the connection from the end time for the connection. Alternatively, the method, system, and computer program product can compute a volume of data received over the connection from the start time for the connection to the end time for the connection.

In another embodiment, time is divided into evenly spaced time slots such that the start time for the connection the end time for the connection can only occur at the end of a time slot. Alternatively, the end time for the connection in the request is specified as a discrete number of time slots.

5 In another embodiment, the system for calculating a cost of receiving multicast data from a multicast session includes a collection device and an interface device. The collection device is a general-purpose computer configured to receive a request to establish a connection to the multicast session, the request including a start time for the connection and an end time for the connection, store the start time for the connection and the end time for the
10 connection, and after termination of the connection, calculate the cost of receiving the multicast data. The interface device is a general-purpose computer configured to configure the collection device and display the cost of receiving the multicast data.

BRIEF DESCRIPTION OF THE DRAWINGS

The accompanying figures best illustrate the details of the system, method, and
15 computer program product that establishes a secure billing system for multicast services in a network that provides link level multicasting, both as to its structure and operation. Like reference numbers and designations in the accompanying figures refer to like elements.

Figure 1A is a network diagram that illustrates an operating environment of a secure
20 billing system for multicast network services in a network that provides link level multicasting.

Figure 1B is a network diagram that illustrates the components comprising the secure billing system shown in Figure 1A.

Figure 1C is a network diagram illustrating an embodiment of the secure billing
25 system shown in Figure 1A that accommodates an indirect connection between user terminal 110 and multicast data network 105.

Figure 1D is a network diagram that illustrates the components comprising the secure billing system shown in Figure 1C.

Figure 1E is a network diagram illustrating an embodiment of the secure billing system shown in Figure 1A that distributes the security function to base station 140 and the charging function to charging server 150.

5 Figure 1F is a network diagram that illustrates the components comprising the secure billing system shown in Figure 1E.

Figure 1G is a network diagram that illustrates the components comprising the secure billing system shown in Figure 1E.

Figures 2A and 2B illustrate a method of operation for the secure billing system shown in Figure 1B.

10 Figures 2C and 2D illustrate a method of operation for the secure billing system shown in Figure 1G.

Figure 3A is an exemplary timeline for a charging scheme based on connection time that illustrates an explicit disjoin.

15 Figure 3B is an exemplary timeline for a charging scheme based on connection time that illustrates an implicit disjoin.

Figure 3C is an exemplary timeline for a charging scheme based on slotted connection time that illustrates an explicit disjoin.

Figure 3D is an exemplary timeline for a charging scheme based on slotted connection time that illustrates an implicit disjoin.

20 Figure 4A is an exemplary timeline for a charging scheme based on data volume that illustrates an explicit disjoin.

Figure 4B is an exemplary timeline for a charging scheme based on data volume that illustrates an implicit disjoin.

DETAILED DESCRIPTION OF THE INVENTION

25 Figure 1A is a network diagram that illustrates an operating environment of a secure billing system for multicast network services in a network that provides link level

multicasting. Internet **100** and multicast data network **105**, as shown in Figure **1A**, are public communication networks that support multicast delivery of data packets, in general, and multicast delivery of Internet protocol (IP) data packets, in particular. The invention disclosed herein contemplates network architectures comparable to Internet **100** and
5 multicast data network **105** such as a cellular network, a satellite network, a digital video broadcasting (DVB) network, or a private network architecture. Private network architectures include a local area network, a personal area network such as a Bluetooth network, an intranet, or an extranet. An intranet is a private communication network that provides an organization, such as a corporation, with a secure means for trusted members of
10 the organization to access the resources on the organization's network. In contrast, an extranet is a private communication network that provides an organization, such as a corporation, with a secure means for the organization to authorize non-members of the organization to access certain resources on the organization's network. The invention disclosed herein also contemplates network protocols such as Ethernet, Token Ring, and
15 proprietary network protocols comparable to the Internet protocol.

As shown in Figure **1A**, user terminal **110** includes an interface module that connects a user to the secure billing system for multicast network services. In one embodiment, user terminal **110** is a general-purpose computer. User terminal **110** also includes a communication module to communicate with devices on multicast data network **105** to
20 receive multicast session data from devices on Internet **100**. A user operates user terminal **110** to receive multicast content **195** by sending join request **117** to last hop router **120**. After receiving join request **117**, last hop router **120** attaches to the multicast tree using any existing multicast routing protocol. In one embodiment, last hop router **120** attaches to the multicast tree via border gateway **180**. Last hop router **120** and border gateway **180** perform
25 routing functions for multicast data network **105**. Last hop router **120** is the last routing entity that handles data passing from multicast capable data network **105** to user terminal **110**. For example, last hop router **120** may be a general-purpose router in a wireless local area network (WLAN) or a Serving General Packet Radio Service (GPRS) Support Node (SGSN) in a GPRS or Universal Mobile Telecommunications System (UMTS) network.

Border gateway **180** is the routing entity that provides the interface between multicast data network **105** and an external network such as Internet **100**. In response to join request **117**, user terminal **110** receives decryption key **118** from multicast data network **105**. In one embodiment, last hop router **120** is responsible for sending decryption key **118** to user terminal **110** and encrypts the data sent by multicast server **190** prior to forwarding the data to user terminal **110**. In addition to data routing, last hop router **120** monitors multicast communication messages that user terminal **110** sends and receives, stores charging data related to a subscription request, and forwards the charging data to billing server **170**, a general-purpose server computer. Billing server **170** converts the charging data into billing data, stores the billing data, and notifies the user of the total charge for subscribing to multicast content **195**.

In another embodiment of the secure billing system shown in Figure **1A**, multicast data network **105** is a visiting wireless network for user terminal **110**. Since billing server **170** is not in the home network for user terminal **110**, billing server **170** forwards any billing data for user terminal **110** to the home billing server (not shown) in the home network (not shown) for user terminal **110**. The home network (not shown) will connect to either multicast data network **105** or Internet **100** via a connecting border gateway (not shown).

In another embodiment of the secure billing system shown in Figure **1A**, the functions comprising collection of the charging data that last hop router **120** performs are distributed throughout multicast data network **105** to reduce the processing load imposed upon last hop router **120**. For example, if the charging data includes connection time data and throughput volume data, last hop router **120** can be responsible for collecting the time data and an intermediate router (not shown) along the multicast tree in multicast data network **105** can be responsible for collecting the throughput volume data.

In another embodiment of the secure billing system shown in Figure **1A**, the operator of multicast data network **105** provides the multicast service. Thus, multicast server **190** is located in multicast data network **105**.

In another embodiment of the secure billing system shown in Figure 1A, billing server 170 is located in another physical network such as Internet 100 and connects with multicast data network 105 via a Virtual Private Network (VPN). Alternatively, last hop router 120 can also include the functionality performed by billing server 170. Thus, last hop router 120 will include a module that converts charging data into billing data, stores the billing data temporarily and periodically forwards the billing data to a billing center.

Figure 1B is a network diagram that illustrates the components comprising the secure billing system shown in Figure 1A. User terminal 110 comprises service discovery 111, multicast session management 112, and multicast security client 113. Service discovery 111 enables the terminal to discover multicast sessions by providing the user with a list of available multicast sessions and the cost associated with each session. Multicast session management 112 is responsible for establishing a multicast session, maintaining the session communication, and disconnecting the session when the communication is complete. Multicast security client 113 manages the security associated with receiving multicast data from a network connection. For example, multicast security client 113 periodically receives decryption key 118 for decrypting the multicast session data.

Referring again to Figure 1B, last hop router 120 is the last routing entity through which IP data destined for user terminal 110 passes. Last hop router 120 comprises routing function 121, group membership management 122, multicast security unit 123, multicast charging unit 124, data volume meter 125, and charging database 126. Routing function 121 performs traditional network routing and provides support for the IP multicast protocol. Group membership management 122 maintains the group membership information for every terminal on the same multicast link and is responsible for determining the join status of each terminal. Multicast security unit 123 is responsible for sending decryption key 118 to user terminal 110. Optionally, multicast security unit 123 may encrypt the multicast data from multicast server 190 before it is sent to user terminal 110. Multicast security unit 123 sends decryption key 118 when the user initially joins a multicast session. Multicast security unit 123 updates decryption key 118 either when another multicast user terminates the session or at discrete time intervals. Multicast security unit 143 communicates decryption key 118 to

multicast security client 113 either by a direct connection, via routing function 121, or via routing function 121 and group membership management 122. Multicast charging unit 124 maintains information related to multicast session charges for user terminal 110. Multicast charging unit 124 creates a charging entry in charging database 126 when user terminal 110 joins a multicast session. Multicast charging unit 124 updates the charging entry when user terminal 110 updates the join status or terminates the session. When user terminal 110 terminates the session, multicast charging unit 124 retrieves the relevant session charge information from charging database 126 and forwards the information to billing server 170. Data volume meter 125 measures, for a multicast session, the number of bytes or data volume transmitted to user terminal 110. Charging database 126 stores information related to multicast session charges. The implementation of charging database 126 contemplates a flat-file architecture, relational database management system design, object-oriented database design, or the equivalent.

Referring again to Figure 1B, billing server 170 is a general-purpose server computer that includes a module to convert charging information such as connection time or data volume into billing data including the cost to receive the multicast session data. Billing server 170 comprises billing unit 171 and billing database 172. Billing unit 171 converts the information related to multicast session charges into billing information. Billing database 172 stores the billing information. The implementation of billing database 172 contemplates a flat-file architecture, relational database management system design, object-oriented database design, or the equivalent.

Figure 1C is a network diagram illustrating an embodiment of the secure billing system shown in Figure 1A that accommodates an indirect connection between user terminal 110 and multicast data network 105. Internet 100 and multicast data network 105 perform the same functions as described above in the discussion of Figure 1A. Bi-directional network 106 is a data network such as a General Packet Radio Service (GPRS) network that supports uplink connectivity and provides an interface between user terminal 110 and multicast data network 105. Uni-directional network 107 is a data network such as a DVB terrestrial (DVB-T) network that transmits multicast data to entities such as user terminal 110. The

invention disclosed herein contemplates network architectures comparable to bi-directional network **106** and uni-directional network **107** such as a cellular network, a satellite network, a DVB network, or a private network architecture.

As shown in Figure **1C**, user terminal **110** includes an interface module that connects
5 a user to the secure billing system for multicast network services. In one embodiment, user terminal **110** is a mobile device such as a cellular telephone. User terminal **110** also includes a communication module to receive multicast data transmitted by multicast serving node **130**.
A user operates user terminal **110** to receive multicast content **195** by sending join request
10 request **117** to multicast serving node **130** via bi-directional network **106**. After receiving join request **117**, multicast serving node **130** attaches to the multicast tree using any existing multicast routing protocol. In one embodiment, multicast serving node **130** attaches to the multicast tree via border gateway **180**. Multicast serving node **130** and border gateway **180** perform routing functions for multicast data network **105**. Multicast serving node **130** forwards the multicast data from multicast data network **105** to user terminal **110** via either
15 bi-directional network **106** or uni-directional network **107**. Border gateway **180** is the routing entity that provides the interface between multicast data network **105** and an external network such as Internet **100**. In response to join request **117**, user terminal **110** receives decryption key **118** from multicast serving node **130** via bi-directional network **106**. In one embodiment, multicast serving node **130** is responsible for sending decryption key **118** to user terminal **110** and encrypts the data sent by multicast server **190** prior to forwarding the data to user terminal **110**. Multicast serving node **130** also forwards the multicast data comprising multicast content **195** to user terminal **110** via uni-directional network **107**. In addition to data routing, multicast serving node **130** monitors multicast communication messages that user terminal **110** sends and receives, stores charging data related to a
20 subscription request, and forwards the charging data to billing server **170**, a general-purpose server computer. Billing server **170** converts the charging data into billing data, stores the billing data, and notifies the user of the total charge for subscribing to multicast content **195**.
25

An example of the embodiment shown in Figure **1C** includes delivering IP data from an Internet Service Provider (ISP) network owned by operator A via a DVB terrestrial (DVB-

T) network owned by operator B to the mobile terminal operated by a user. A service agreement between the user and operator A obligates the user to pay a fee for receiving multicast data that operator A delivers. Also, an agreement between operator A and operator B obligates operator A to pay a fee for sending data over the DVB-T network owned by operator B. To subscribe to a multicast session, the user sends join request 117 to multicast serving node 130 via the data network owned by operator C. Multicast serving node 130 delivers multicast session data to the mobile terminal via the DVB-T network owned by operator B, monitors multicast communication messages, stores charging data related to the subscription request, and forwards the charging data to billing server 170.

10 Figure 1D is a network diagram that illustrates the components comprising the secure billing system shown in Figure 1C. Except for the differences described below, the function and structure of the components shown in Figure 1D are identical to the components shown in Figure 1B. Multicast serving node 130 performs the functions described for last hop router 120 in the discussion of Figure 1B. In Figure 1D, routing function 131 and multicast security unit 133 do not communicate with user terminal 110 directly, but via either bi-directional network 106 or uni-directional network 107. Similarly, multicast session management 112 does not communicate with multicast serving node 130 directly, but via bi-directional network 106.

20 Figure 1E is a network diagram illustrating an embodiment of the secure billing system shown in Figure 1A that distributes the security function to base station 140 and the charging function to charging server 150. As shown in Figure 1E, user terminal 110 is a mobile device that communicates with wireless network 108 via base station 140. In one embodiment, base station 140 is the base station subsystem in a GPRS network. A user operates user terminal 110 to receive multicast content 195 by sending join request 117 to base station 140. After receiving join request 117, base station 140 attaches to the multicast tree using any existing multicast routing protocol. In one embodiment, base station 140 attaches to the multicast tree via last hop router 120 and border gateway 180. Last hop router 120 and border gateway 180 perform routing functions for wireless network 108. In response to join request 117, user terminal 110 receives decryption key 118 from base station

140. In one embodiment, base station 140 is responsible for sending decryption key 118 to user terminal 110 and encrypts the data sent by multicast server 190 prior to forwarding the data to user terminal 110. In addition to data routing, the connection between last hop router 120 and base station 140 allow last hop router 120 to monitor multicast communication messages that user terminal 110 sends to and receives from base station 140. Last hop router 120 also transfers charging data related to a subscription request to charging server 150. In one embodiment, charging server 150 stores the charging data and periodically forwards the data via a direct connection to billing server 170. In another embodiment, charging server 150 stores the charging data and periodically forwards the data to billing server 170 via a connection between last hop router 120 and billing server 170. Charging server 150 and billing server 170 are general-purpose server computers.

Figure 1F is a network diagram that illustrates the components comprising the secure billing system shown in Figure 1E. Except for the differences described below, the function and structure of the components shown in Figure 1F are identical to the components shown in Figure 1B. Figure 1F distributes the components of last hop router 120, as shown in Figure 1B, among last hop router 120, base station 140, and charging server 150. Last hop router 120 comprises routing function 121, group membership management 122, and data volume meter 125. Base station 140 comprises multicast security unit 123, the communication interface between multicast security unit 123 and routing function 121, and the communication interface between multicast security unit 123 and group membership management 122. Charging server 150 comprises multicast charging unit 124, charging database 126, the communication interface between multicast charging unit 124 and group membership management 122, and the communication interface between multicast charging unit 124 and data volume meter 125. In one embodiment, billing server 170 comprises billing unit 171 and billing database 172 and charging server 150 further comprises a communication interface between charging unit 124 and billing unit 171.

Figure 1G is a network diagram that illustrates the components comprising the secure billing system shown in Figure 1E. Except for the differences described below, the function and structure of the components shown in Figure 1G are identical to the components shown

in Figure 1F. Figure 1G illustrates a distributed architecture for group membership management 122 shown in Figure 1F. Last hop router 120, as shown in Figure 1G, comprises routing function 121, data volume meter 125, and network layer group membership management 128. Base station 140, as shown in Figure 1G, comprises multicast security unit 123, link layer group membership management 127, the communication interface between multicast security unit 123 and routing function 121, and the communication interface between link layer group membership management 127 and network layer group membership management 128. Charging server 150, as shown in Figure 1G, comprises multicast charging unit 124, charging database 126, the communication interface between multicast charging unit 124 and network layer group membership management 128, and the communication interface between multicast charging unit 124 and data volume meter 125. Link layer group membership management 127 maintains the information of the join status of user terminal 110 within the cell and provides that information to multicast charging unit 124. Whenever there are any multicast receivers within the cell, link layer group membership management 127 informs network layer group membership management 128 to join the multicast tree. Network layer group membership management 128 is responsible for keeping track of which base station needs multicast data and routes the multicast data to the appropriate base station.

Figures 2A and 2B illustrate a method of operation for the secure billing system shown in Figure 1B. Referring to Figures 1A and 2A, the method begins at step 202 with multicast server 190 announcing the available multicast sessions to user terminal 110 via multicast data network 105. At step 204, service discovery 111 discovers the multicast sessions that are available. Service discovery 111 provides an operator of user terminal 110 with a list of available multicast sessions and the relevant information for each session. The relevant information includes the starting time and cost associated with a multicast session. The operator selects a multicast session from the list. In response to the operator's selection, user terminal 110 activates the selected multicast session. In one embodiment, the activation of the multicast session occurs immediately. In another embodiment, the activation occurs at a predetermined time such as before the start of the multicast session. At step 206, multicast

session management 112 sends join request 117 for the selected multicast session to group membership management 122. Group membership management 122 receives join request 117 at step 208 and records the join status of the user terminal at step 212. Group membership management 122 forwards the joined status information to multicast charging unit 124 and multicast security unit 123. Multicast charging unit 124 uses the joined status information to create a charging entry in charging database 146 at step 214. Multicast security unit 123 uses the joined status information to send a decryption key to user terminal 110 at step 216 which multicast security client 113 receives at step 218 before receiving multicast session data at step 220. In one embodiment, multicast security unit 123 encrypts the message prior to sending the decryption key and multicast security client 113 decrypts the message after receiving the decryption key. After receiving join request 117 at step 208, group membership management 122 also attaches to the multicast tree using any multicast routing protocol at step 210. In one embodiment, group membership management 122 applies authentication and authorization procedures before attaching to the multicast tree. At step 222, multicast server 190 sends multicast session data to multicast security unit 123. The multicast session data is encrypted by multicast security unit 123 at step 224 and decrypted by multicast security client 113 at step 226 before receiving multicast session data at step 220.

At step 228, Figure 2A illustrates user terminal 110 updating the join status, for example, to extend the duration of the multicast session connection. Multicast session management 112 resends the join request to group membership management 122. Group membership management 122 updates the join status for user terminal 110 at step 230 and notifies multicast security unit 123 to send an updated decryption key at step 216. Multicast session management 112 is responsible for sending an updated join request to last hop router 120 on an on-going basis. As long as the user is receiving the session, multicast session management 113 must update the join status for the terminal before it expires. Whenever the join status is updated, group membership management 122 also forwards the status to multicast charging unit 124 to update the charging entry at step 232. After updating the join

status for user terminal 110 at step 230, group membership management 122 notifies multicast charging unit 124 to update the charging entry in charging database 126 at step 232.

At step 234, Figure 2B illustrates user terminal 110 terminating the multicast session, either explicitly or implicitly, by sending a disjoin message to last hop router 140. Group membership management 122 receives the disjoin message and, at step 236, notifies multicast charging unit 124 to close the charging entry for user terminal 110 in charging database 126. Multicast charging unit 124 forwards the charging data to billing server 170 at step 238. Billing server 170 converts the charging data to billing data, at step 240, and sends the billing data to the user at step 242. If a data volume based charging mechanism is used, in order to generate and update the charging entry, data volume meter 125 forwards to multicast charging unit 124 the volume of data delivered to user terminal 110. At step 244, group membership management 122 determines whether any receivers of the multicast data have an active join status. If no receivers have an active join status, at step 246, group membership management 122 detaches user terminal 110 from the multicast tree. If there is at least one receiver with an active status, group membership management 122 proceeds to steps 230 and 216 where the terminal status is updated and multicast security unit 123 is notified to send an updated decryption key to multicast security client 113.

Figures 2C and 2D illustrate a method of operation for the secure billing system shown in Figure 1G. Referring to Figures 1E and 2C, the method begins at step 202 with multicast server 190 announcing the available multicast sessions to user terminal 110 via wireless network 108. At step 204, service discovery 111 discovers the multicast sessions that are available. Service discovery 111 provides an operator of user terminal 110 with a list of available multicast sessions and the relevant information for each session. The relevant information includes the starting time and cost associated with a multicast session. The operator selects a multicast session from the list. In response to the operator's selection, user terminal 110 activates the selected multicast session. In one embodiment, the activation of the multicast session occurs immediately. In another embodiment, the activation occurs at a predetermined time such as before the start of the multicast session. At step 206, multicast session management 112 sends join request 117 for the selected multicast session to link

layer group membership management 127. Link layer group membership management 127 receives join request 117 at step 208 and records the join status of the user terminal at step 212. Link layer group membership management 127 forwards the joined status information to multicast charging unit 124 and multicast security unit 123. Multicast charging unit 124 uses the joined status information to create a charging entry in charging database 146 at step 214. Multicast security unit 123 uses the joined status information to send a decryption key to user terminal 110 at step 216 which multicast security client 113 receives at step 218 before receiving multicast session data at step 220. In one embodiment, multicast security unit 123 encrypts the message prior to sending the decryption key and multicast security client 113 decrypts the message after receiving the decryption key. After receiving join request 117 at step 208, link layer group membership management 127 also notifies network layer group membership management 128 to attach to the multicast tree using any multicast routing protocol at step 210. In one embodiment, link layer group membership management 127 applies authentication and authorization procedures before attaching to the multicast tree. At step 222, multicast server 190 sends multicast session data to multicast security unit 123. The multicast session data is encrypted by multicast security unit 123 at step 224 and decrypted by multicast security client 113 at step 226 before receiving multicast session data at step 220.

At step 228, Figure 2C illustrates user terminal 110 updating the join status, for example, to extend the duration of the multicast session connection. Multicast session management 112 resends the join request to link layer group membership management 127. Link layer group membership management 127 updates the join status for user terminal 110 at step 230 and notifies multicast security unit 123 to send an updated decryption key at step 216. Multicast session management 112 is responsible for sending an updated join request to last hop router 120 on an on-going basis. As long as the user is receiving the session, multicast session management 113 must update the join status for the terminal before it expires. Whenever the join status is updated, link layer group membership management 127 also forwards the status to multicast charging unit 124 to update the charging entry at step 232. After updating the join status for user terminal 110 at step 230, link layer group

membership management 127 notifies multicast charging unit 124 to update the charging entry in charging database 126 at step 232.

At step 234, Figure 2D illustrates user terminal 110 terminating the multicast session, either explicitly or implicitly, by sending a disjoin message to last hop router 140. Link layer group membership management 127 receives the disjoin message and, at step 236, notifies multicast charging unit 124 to close the charging entry for user terminal 110 in charging database 126. Multicast charging unit 124 forwards the charging data to billing server 170 at step 238. Billing server 170 converts the charging data to billing data, at step 240, and sends the billing data to the user at step 242. If a data volume based charging mechanism is used, in order to generate and update the charging entry, data volume meter 125 forwards to multicast charging unit 124 the volume of data delivered to user terminal 110. At step 244, link layer group membership management 127 determines whether any receivers of the multicast data have an active join status. If no receivers have an active join status, link layer group membership management 127 notifies network layer group membership management 128, at step 246, to detach user terminal 110 from the multicast tree. If there is at least one receiver with an active status, link layer group membership management 127 proceeds to steps 230 and 216 where the terminal status is updated and multicast security unit 123 is notified to send an updated decryption key to multicast security client 113.

Connection Time Charging

A charging scheme based on connection time calculates a fee for a service from the elapsed time that a user connects to the service. For example, if a network operator determines that the rate for using a video service is \$5.00 per hour, a user connecting to the video service to view a movie for thirty-minutes accrues a fee of \$2.50. In a multicast network, a charging scheme based on connection time is most beneficial when an average multicast session has a fixed bandwidth. Determination of the connection time involves storing the time that the user terminates the multicast session connection, storing the time that the user initiates the multicast session connection, and calculating the difference between these times. Since a multicast session is dynamic, the challenge is to determine when the initiation and termination of the connection occurs.

The packets that comprise a multicast session are encrypted. Thus, a user cannot receive the multicast session without explicitly requesting to join a multicast group and receiving a decryption key. Referring to Figure 1B, service discovery 171 receives all the available multicast sessions from last hop router 140. When user terminal 170 selects and activates a multicast session, multicast session management 172 explicitly requests to join a multicast group by sending join message 160 to group membership management 142. In response, group membership management 142 notifies multicast charging unit 144 and multicast security unit 143 that user terminal 170 agrees to pay a fee based on the connection time to the multicast service. Multicast charging unit 144 creates a charging entry for user terminal 170 and multicast content 110. Multicast security client 173 receives decryption key 165 from multicast security unit 143 that will decrypt the multicast session packet data. Group membership management 142 receives every join message sent by a user of the multicast service associated with a multicast group. A validated or authenticated join message activates the "joined" status for the user who sent the join message. Multicast charging unit 144 creates and maintains an entry in charging database 146 for each validated join message. The entry in charging database 146 comprises user identification data, session identification data, a cumulative connection time, and an expiration time for the "joined" status.

The join message sent by the user identifies the requested multicast session, the requested start time for the charging, and the requested stop time for the charging. The join message obligates the user to pay the charges that accrue from the start time to the end time. When the user has "joined" status, the multicast network is responsible for updating the user's "decryption key" whenever host membership in the multicast group changes. For a discussion of several methods for delivery of the decryption key see "Secure Group Communication using Key Graphs", IEEE/ACM Transactions on Networking, February 2000.

The stop time specified in the join message is the initial stop time for the user's multicast session. The user can extend the stop time by sending a second join message to specify a later stop time. The stop time can only be extended if group membership

management **142** receives the second join message prior to the initial stop time. If the second join message arrives after the first join status expires, the user will be disconnecting with the multicast session first as a result of the expired join status. When the second join message arrives, it will act as a new join message to connect user terminal **110** to the multicast session. Following the receipt of a second or subsequent join message, multicast charging unit **144** updates the entry for the user and multicast session in charging database **146** and notifies other group members of a membership change.

In one embodiment, the interval between the start time and the stop time in each join message can be determined based on the configuration set by either the user or network operator. In another embodiment, the interval between the start time and the stop time can be calculated according to an environmental characteristic including the velocity of the terminal, the strength of the reception signal, and the quality of the reception signal.

Termination of the multicast session can happen either explicitly or implicitly. Explicit termination of the multicast session occurs when the user sends a disjoin message that specifies a stop time earlier than the pending stop time. A disjoin message is only effective, however, if group membership management **142** receives the disjoin message prior to the pending stop time. Following receipt of a disjoin message, multicast charging unit **144** updates and closes the entry in charging database **146** and forwards the charging data to billing unit **151** for conversion into billing data and storage in billing database **152**. If the forwarding of the charging data is successful, multicast charging unit **144** deletes the entry in charging database **146** and, if the second join message arrives after the first join status expires, multicast security unit **143** updates decryption key **165** for other group members of the same multicast session. Implicit termination of the multicast session occurs when the user's "joined" status expires before the user sends a subsequent join message to extend the stop time. An implicit termination may occur, for example, when the battery in the user's terminal loses power or some other reason that causes terminal to loose the network connection. Accounting for implicit termination of a multicast session ensures that an excessive charge does not accrue for the user.

When the user status changes state from “joined” to “disjoined”, multicast charging unit **144** calculates the total connection time. The billing related information such as user identification data, session identification data, and connection time is transferred from multicast charging unit **144** to billing server **150**. Then, billing unity **151** converts the charging data into billing data and stores the billing data in billing database **152**.
 5 Alternatively, multicast charging unit **144** periodically transfers billing data to billing server **150**.

UNRESTRICTED CONNECTION TIME

10 Figures **3A** and **3B** are exemplary timelines for a charging scheme based on connection time that allows a user to join or leave a multicast session at any time. Referring to Figures **1B** and **3A**, if user terminal **170** explicitly requests termination of the multicast session connection, determination of the connection time comprises:

1. User terminal **170** sending a join message to group membership management **142** at time t_{X0} . If the join message takes the form $\text{join}(p, t_{S1}, t_{E1})$, the user is requesting to join
 15 multicast session p , start the connection time charging at time t_{S1} , and end the connection time charging at time t_{E1} . If the user wants to start the connection time charging immediately, t_{S1} is set equal to null.
2. Multicast security client **173** receiving decryption key **165** from multicast security unit **143** before time t_{S1} . Decryption key **165** functions to decrypt the packet data comprising
 20 multicast session p .
3. At time t_{S1} , multicast charging unit **144** adds an entry to charging database **146** to track connection time charges for user terminal **170** using multicast session p . In one embodiment, the entry to charging database **146** appears as follows:

User Identification	Session Identification	Connection Time	Expiration Time of “Joined” Status
21323421	finnkino 457286529 1453 172.10.20.212	$(t_{E1} - t_{S1})$	t_{E1}

If the user sets t_{S1} in the join message equal to null to indicate that the connection time charging will start immediately, t_{X0} will replace t_{S1} in the charging table because the join message was sent at time t_{X0} .

4. From time t_{S1} until time t_{E1} , the multicast network is responsible for updating decryption key **165** for user terminal **170** whenever host membership in the multicast group changes.
5. At time t_{X1} , where $t_{X1} < t_{E1}$, user terminal **170** extends the stop time by sending a second join message to specify a later stop time. If the second join message takes the form $\text{join}(p, t_{E1}, t_{E2})$, the user is requesting to extend the end time for the connection to multicast session p from time t_{E1} to time t_{E2} .
- 10 6. At time t_{E1} , multicast charging unit **144** updates the entry in charging database **146** to track connection time charges for user terminal **170** using multicast session p . In one embodiment, the entry to charging database **146** appears as follows:

User Identification	Session Identification	Connection Time	Expiration Time of "Joined" Status
21323421	finnkino 457286529 1453 172.10.20.212	$(t_{E1} - t_{S1})$ + $(t_{E2} - t_{E1})$	t_{E2}

7. From time t_{E1} until time t_{E2} , the multicast network is responsible for updating the "decryption key" for user terminal **170** whenever host membership in the multicast group changes.
- 15 8. At time t_{X2} , where $t_{X2} < t_{E2}$, user terminal **170** sends a disjoin message that specifies a stop time earlier than the pending stop time, t_{E2} . If the disjoin message takes the form $\text{leave}(p, t_{E3})$, user terminal **170** is requesting to leave multicast session p at time t_{E3} . If user terminal **170** wants to leave multicast session p immediately, t_{E3} is set equal to null.
- 20 Multicast charging unit **144** updates the entry in charging database **146** to track connection time charges for user terminal **170** using multicast session p . In one embodiment, the entry to charging database **146** appears as follows:

User Identification	Session Identification	Connection Time	Expiration Time of "Joined" Status
21323421	finnkino 457286529 1453 172.10.20.212	$(t_{E1} - t_{S1})$ + $(t_{E2} - t_{E1})$ + $(t_{E3} - t_{E2})$	t_{E3}

If the user sets t_{E3} in the disjoin message equal to null to indicate that user terminal 170 wants to leave multicast session p immediately, t_{X2} will replace t_{E3} in the charging table because the join message was sent at time t_{X2} .

9. At time t_{E3} , collection of connection time charges for user terminal 170 stops. The multicast network is responsible for updating the "decryption key" for the other group members because user terminal 170 disjoined the multicast group. Since the collection of connection time charges has stopped, multicast charging unit 144 closes the entry in charging database 146 for user terminal 170 using multicast session p , communicates the charging data to billing unit 151 for storage in billing database 152, and deletes the entry in charging database 146.

Referring to Figures 1B and 3B, if termination of the multicast session connection is implied from the passage of time, steps 1 through 7 are identical to steps 1 through 7 from the discussion of Figure 3A and determination of the connection time comprises:

1. User terminal 170 sending a join message to group membership management 142 at time t_{X0} . If the join message takes the form $\text{join}(p, t_{S1}, t_{E1})$, the user is requesting to join multicast session p , start the connection time charging at time t_{S1} , and end the connection time charging at time t_{E1} . If the user wants to start the connection time charging immediately, t_{S1} is set equal to null.
2. Multicast security client 173 receiving decryption key 165 from multicast security unit 143 before time t_{S1} . Decryption key 165 functions to decrypt the packet data comprising multicast session p .

3. At time t_{S1} , multicast charging unit 144 adds an entry to charging database 146 to track connection time charges for user terminal 170 using multicast session p . In one embodiment, the entry to charging database 146 appears as follows:

User Identification	Session Identification	Connection Time	Expiration Time of "Joined" Status
21323421	finnkino 457286529 1453 172.10.20.212	$(t_{E1} - t_{S1})$	t_{E1}

5 If the user sets t_{S1} in the join message equal to null to indicate that the connection time charging will start immediately, t_{X0} will replace t_{S1} in the charging table because the join message was sent at time t_{X0} .

4. From time t_{S1} until time t_{E1} , the multicast network is responsible for updating decryption key 165 for user terminal 170 whenever host membership in the multicast group changes.
5. At time t_{X1} , where $t_{X1} < t_{E1}$, user terminal 170 extends the stop time by sending a second join message to specify a later stop time. If the second join message takes the form $\text{join}(p, t_{E1}, t_{E2})$, the user is requesting to extend the end time for the connection to multicast session p from time t_{E1} to time t_{E2} .
- 10
6. At time t_{E1} , multicast charging unit 144 updates the entry in charging database 146 to track connection time charges for user terminal 170 using multicast session p . In one embodiment, the entry to charging database 146 appears as follows:
- 15

User Identification	Session Identification	Connection Time	Expiration Time of "Joined" Status
21323421	finnkino 457286529 1453 172.10.20.212	$(t_{E1} - t_{S1})$ $+ (t_{E2} - t_{E1})$	t_{E2}

7. From time t_{E1} until time t_{E2} , the multicast network is responsible for updating the "decryption key" for user terminal 170 whenever host membership in the multicast group changes.

8. At time t_{E2} , the connection time charging for user terminal 170 expires. Multicast charging unit 144 stops updating the entry for user terminal 170 using multicast session p in charging database 146. Multicast charging unit 144 communicates with billing server 150 to transfer the charging data for user terminal 170 using multicast session p from charging database 146 to billing database 151. Billing unit 151 converts the connection time, data volume, or other form of information for user terminal 170 using multicast session p to the entry of billing database 151, which has information of total cost of multicast session for user terminal 170. Alternatively, the entry in charging database 146 is transferred periodically to billing server 150. In one embodiment, the entry to charging database 146 appears as follows:

User Identification	Session Identification	Connection Time	Expiration Time of "Joined" Status
21323421	finnkino 457286529 1453 172.10.20.212	$(t_{E1} - t_{S1})$ $+ (t_{E2} - t_{E1})$	t_{E2}

HANDOVER

The following examples describe how the system performs charging when a handover occurs from node A to node B. In the first example, the system configuration is as shown in Figure 1B and the handover is from one last hop router to another. User terminal 110 needs to send a new join message to node B and a disjoin message to node A. Alternatively, node B can inform node A of the handover and disjoin user terminal 110 from node A. All of the components in node A (group membership management 122, multicast charging unit 124, multicast security unit 124, etc.) will follow the disjoin procedure as described herein. All of the components in node B (group membership management 122, multicast charging unit 124, multicast security unit 124, etc.) will follow the join procedure as described herein.

In the second example, the system configuration is as shown in Figure 1B and nodes A and B are equipped with independent group membership management components or link layer group membership management components, but share the same multicast charging unit or charging server. User terminal 110 joins the multicast session from node A and later

performs a handover from node A to node B. Since node A and node B are both equipped with group membership management or link layer group membership management components, the nodes support charging in a handover situation if a column is added to the charging entry to identify which node is responsible for the charging entry. When node A, in response to a join request, instructs multicast charging unit 124 to create a charging entry for user terminal 110, the ID of node A (e.g., the IP address of node A) is recorded in the charging entry as the “node responsible for this charging entry”. When user terminal 110 performs a handover from node A to node B, user terminal 110 sends a join request to node B. As a result, node B sends a request for creating charging entry to multicast charging unit 124 that is shared by node A and node B. Upon receiving such a request, multicast charging unit 124 updates the relevant entry by changing the “node responsible for this charging entry” to node B and updating the “joined status expire time” to the new one indicated in the new join message. In addition, multicast charging unit 124 informs node A that node A is no longer responsible for the charging entry associated with user terminal 110. Node a may perform the disjoin procedure described herein to disjoin user terminal 110 from node A.

For example, before handover, user terminal 110 receives multicast data via node A. The charging entry is:

User Identification	Session Identification	Node Responsible for this Entry	Connection Time	Expiration Time of “Joined” Status
21323421	finnkino 457286529 1453 172.10.20.212	ID of node A	$(t_{E1} - t_{S1})$ + $(t_{E2} - t_{E1})$ + $(t_{E3} - t_{E2})$	t_{E3}

Then user terminal 110 begins to perform the handover. At time t_{H1} , where $t_{X2} < t_{E3}$, node B with group membership management component receives the join message $join(p, null, t_{E4})$ from user terminal 110. Node B informs multicast charging unit 124 to create a charging entry for user terminal 110. In response, multicast charging unit 124 modifies the existing charging entry in the following manner.

User Identification	Session Identification	Node Responsible for this Entry	Connection Time	Expiration Time of "Joined" Status
21323421	finnkino 457286529 1453 172.10.20.212	ID of node B	$(t_{E1} - t_{S1})$ + $(t_{E2} - t_{E1})$ + $(t_{E4} - t_{E2})$	t_{E4}

Also, multicast charging unit 124 will inform node A that node A is no longer responsible for the charging entry associated with user terminal 110. Node A may perform disjoin procedures to disjoin user terminal 110 from node A.

SLOTTED CONNECTION TIME

5 Figures 3C and 3D are exemplary timelines for a charging scheme based on connection time that only allows a user to join or leave a multicast session at the end of a discrete point in time or time slot. Since the user can only join or leave the multicast session at slotted time intervals (i.e., discrete points in time), the network only needs to update to the decryption key at those discrete points in time. Thus, the network can synchronize the disjoin activity of multiple users and reduce the number of decryption keys delivered.
 10 Referring to Figures 1B and 3C, if user terminal 170 explicitly requests termination of the multicast session connection, determination of the connection time comprises:

1. User terminal 170 sending a join message to group membership management 142 at time t_{X0} . If the join message takes the form $join(p, t_{S1}, 2)$, the user is requesting to join
 15 multicast session p , start the connection time charging at time t_{S1} , and pay for the service from the start time until time $t_3 = [(t_0 + m - t_{S1}) + (2 \times m)]$ where m is the duration of a time slot and t_0 is the start of a time slot.
2. Multicast security client 173 receiving decryption key 165 from multicast security unit 143 before time t_{S1} . The multicast network informs user terminal 170 that time t_{D1} is the
 20 deadline for extending the expiration of the connection to multicast session p . The offset w is defined by the network and represents the time interval between the deadline for receiving another join message and the end of a time slot.

3. At time t_{S1} , multicast charging unit 144 adds an entry to charging database 146 to track connection time charges for user terminal 170 using multicast session p . In one embodiment, the entry to charging database 146 appears as follows:

User Identification	Session Identification	Connection Time	Expiration Time of "Joined" Status
21323421	finnkino 457286529 1453 172.10.20.212	$[(t_0 + m - t_{S1}) + (2 \times m)]$	t_3

4. From time t_{S1} until time t_3 , the multicast network is responsible for updating decryption key 165 for user terminal 170 whenever host membership in the multicast group changes. The updates to decryption key 165 occur during the offset interval w for each time slot. During the offset interval w , if the network determines that the status for a user will change from "joined" to "disjoined", the network updates decryption key 165.
5. At time t_{X1} , where $t_{X1} < t_{D1}$, user terminal 170 extends the stop time by sending a second join message to specify a later stop time. If the second join message takes the form $\text{join}(p, t_3, 2)$, the user is requesting to extend the end time for the connection to multicast session p for 2 time slots after time t_3 . In one embodiment, the entry to charging database 146 appears as follows:

User Identification	Session Identification	Connection Time	Expiration Time of "Joined" Status
21323421	finnkino 457286529 1453 172.10.20.212	$[(t_0 + m - t_{S1}) + (2 \times m) + (2 \times m)]$	t_5

The multicast network informs user terminal 170 that time t_{D2} is the deadline for extending the expiration of the connection to multicast session p .

6. From time t_3 to time t_5 , the multicast network is responsible for updating decryption key 165 for user terminal 170 whenever host membership in the multicast group changes.
7. At time t_{X2} , where $t_{X2} < t_{D2}$, user terminal 170 sends a disjoin message that specifies to stop accruing a fee when the current time slot expires. If the disjoin message takes the

form $\text{leave}(p, 0)$, user terminal **170** is requesting to leave session p when the current time slot expires. In one embodiment, the entry to charging database **146** appears as follows:

User Identification	Session Identification	Connection Time	Expiration Time of "Joined" Status
21323421	finnkino 457286529 1453 172.10.20.212	$(t_0 + m - t_{S1})$ $+ (2 \times m) + (2 \times m)$ $- (t_5 - t_4)$	t_4

8. After time $(t_4 - w)$, if the network determines that the status for a user will change from "joined" to "disjoined", the network updates decryption key **165** and continues the multicast session for the user into the next time slot.
9. At time t_4 , collection of connection time charges for user terminal **170** stops. The multicast network is responsible for updating the "decryption key" for the other group members because user terminal **170** disjoined the multicast group. Since the collection of connection time charges has stopped, multicast charging unit **144** closes the entry in charging database **146** for user terminal **170** using multicast session p , communicates the charging data to billing unit **151** for storage in billing database **152**, and deletes the entry in charging database **146**.

Referring to Figures **1B** and **3D**, if termination of the multicast session connection is implied from the passage of time, steps 1 through 6 are identical to steps 1 through 6 from the discussion of Figure **3C** and determination of the connection time comprises:

1. User terminal **170** sending a join message to group membership management **142** at time t_{X0} . If the join message takes the form $\text{join}(p, t_{S1}, 2)$, the user is requesting to join multicast session p , start the connection time charging at time t_{S1} , and pay for the service from the start time until time $t_3 = [(t_0 + m - t_{S1}) + (2 \times m)]$ where m is the duration of a time slot and t_0 is the start of a time slot.
2. Multicast security client **173** receiving decryption key **165** from multicast security unit **143** before time t_{S1} . The multicast network informs user terminal **170** that time t_{D1} is the deadline for extending the expiration of the connection to multicast session p . The offset

w is defined by the network and represents the time interval between the deadline for receiving another join message and the end of a time slot.

3. At time t_{S1} , multicast charging unit 144 adds an entry to charging database 146 to track connection time charges for user terminal 170 using multicast session p . In one embodiment, the entry to charging database 146 appears as follows:

User Identification	Session Identification	Connection Time	Expiration Time of "Joined" Status
21323421	finnkino 457286529 1453 172.10.20.212	$[(t_0 + m - t_{S1}) + (2 \times m)]$	t_3

4. From time t_{S1} until time t_3 , the multicast network is responsible for updating decryption key 165 for user terminal 170 whenever host membership in the multicast group changes. The updates to decryption key 165 occur during the offset interval w for each time slot. During the offset interval w , if the network determines that the status for a user will change from "joined" to "disjoined", the network updates decryption key 165.

5. At time t_{X1} , where $t_{X1} < t_{D1}$, user terminal 170 extends the stop time by sending a second join message to specify a later stop time. If the second join message takes the form $\text{join}(p, t_3, 2)$, the user is requesting to extend the end time for the connection to multicast session p for 2 time slots after time t_3 . In one embodiment, the entry to charging database 146 appears as follows:

User Identification	Session Identification	Connection Time	Expiration Time of "Joined" Status
21323421	finnkino 457286529 1453 172.10.20.212	$[(t_0 + m - t_{S1}) + (2 \times m) + (2 \times m)]$	t_5

The multicast network informs user terminal 170 that time t_{D2} is the deadline for extending the expiration of the connection to multicast session p .

6. From time t_3 to time t_5 , the multicast network is responsible for updating decryption key 165 for user terminal 170 whenever host membership in the multicast group changes.

7. After time t_{D2} , if the network determines that the status for a user will change from “joined” to “disjoined”, the network updates decryption key 165 and continues the multicast session for the user into the next time slot.
8. At time t_5 , collection of connection time charges for user terminal 170 stops. The multicast network is responsible for updating the “decryption key” for the other group members because user terminal 170 disjoined the multicast group. Since the collection of connection time charges has stopped, multicast charging unit 144 closes the entry in charging database 146 for user terminal 170 using multicast session p , communicates the charging data to billing unit 151 for storage in billing database 152, and deletes the entry in charging database 146. Alternatively, multicast charging unit 144 transfers the entry directly to billing server 150. In another embodiment, the entry to charging database 146 appears as follows:

User Identification	Session Identification	Connection Time	Expiration Time of “Joined” Status
21323421	finnkino 457286529 1453 172.10.20.212	$(t_0 + m - t_{S1})$ $+ (2 \times m) + (2 \times m)$	t_5

Data Volume Based Charging

A charging scheme based on the volume of data calculates a fee for a service from the volume of data that a user receives from the service. For example, if a network operator determines that the rate for using a video service is \$0.25 for each Megabyte of data received, a user connecting to the video service to view a movie consisting of 25 Megabytes of data accrues a fee of \$6.25. In a multicast network, a charging scheme based on the volume of data is most beneficial when the data rate varies. Similar to the charging scheme based on connection time discussed above, the connectivity and security is managed on time basis, however, determination of charge requires accounting for the number of bytes transferred during the connection time.

Figures 4A and 4B are exemplary timelines for a charging scheme based on data volume that only allows a user to join or leave a multicast session at the end of a discrete

point in time or time slot. Referring to Figures 1B and 4A, if user terminal 170 explicitly requests termination of the multicast session connection, determination of the data volume comprises:

1. Data volume meter 145 examining IP multicast data packets and maintaining a tally of the number of bytes of data received, for a given destination address and multicast session. Data volume meter 145 can either be co-located with multicast charging unit 144 or located on an upper layer of the multicast tree (e.g., on the gateway router where the multicast data enters the multicast network). In one embodiment, each last hop router may include a meter for measuring the multicast session routed to the last hop router. In another embodiment, the meter can be distributed across several access routers in the multicast network.
2. User terminal 170 sending a join message to group membership management 142 at time t_{x0} . If the join message takes the form $\text{join}(p, t_{s1}, 2)$, the user is requesting to join multicast session p , start the connection time charging at time t_{s1} , and pay for the service from the start time until time $t_3 = [(t_0 + m - t_{s1}) + (2 \times m)]$ where m is the duration of a time slot and t_0 is the start of a time slot. Calculation of the fee depends on the volume of data received by a given destination and multicast session between time t_{s1} and t_3 .
3. Multicast security client 173 receiving decryption key 165 from multicast security unit 143 before time t_{s1} . The multicast network informs user terminal 170 that time t_{D1} is the deadline for sending another join message. The offset w is defined by the network and represents the time interval between the deadline for receiving another join message and the end of a time slot.
4. At time t_{s1} , data volume meter 145 signals multicast charging unit 144 to add an entry to charging database 146 to store the data volume start value, V_1 , for user terminal 170 using multicast session p . In one embodiment, the entry to charging database 146 appears as follows:

User Identification	Session Identification	Data Volume on Meter		Expiration Time of "Joined" Status
		Start Value	End Value	
21323421	finnkino 457286529 1453 172.10.20.212	V_1	Null	t_3

5. From time t_{S1} until time t_3 , the multicast network is responsible for updating decryption key **165** for user terminal **170** whenever host membership in the multicast group changes. The updates to decryption key **165** occur during the offset interval w for each time slot. During the offset interval w , if the network determines that the status for a user will change from "joined" to "disjoined", the network updates decryption key **165**.
6. At time t_{X1} , where $t_{X1} < t_{D1}$, user terminal **170** extends the stop time by sending a second join message to specify a later stop time. If the second join message takes the form $\text{join}(p, t_3, 2)$, the user is requesting to extend the end time for the connection to multicast session p for 2 time slots after time t_3 . In one embodiment, the entry to charging database **146** appears as follows:

User Identification	Session Identification	Data Volume on Meter		Expiration Time of "Joined" Status
		Start Value	End Value	
21323421	finnkino 457286529 1453 172.10.20.212	V_1	Null	t_5

The multicast network informs user terminal **170** that time t_{D2} is the deadline for extending the expiration of the connection to multicast session p .

7. From time t_3 to time t_5 , the multicast network is responsible for updating decryption key **165** for user terminal **170** whenever host membership in the multicast group changes.
8. At time t_{X2} , where $t_{X2} < t_{D2}$, user terminal **170** sends a disjoin message that specifies to stop accruing a fee when the current time slot expires. If the disjoin message takes the

form $leave(p, 0)$, user terminal **170** is requesting to leave session p when the current time slot expires. In one embodiment, the entry to charging database **146** appears as follows:

User Identification	Session Identification	Data Volume on Meter		Expiration Time of "Joined" Status
		Start Value	End Value	
21323421	finnkino 457286529 1453 172.10.20.212	V_1	Null	t_4

9. After time $(t_4 - w)$, if the network determines that the status for a user will change from "joined" to "disjoined", the network updates decryption key **165** and continues the multicast session for the user into the next time slot.
10. At time t_4 , collection of the data volume charges for user terminal **170** stops. Data volume meter **145** communicates the data volume end value, V_2 , for user terminal **170** using multicast session p to multicast charging unit **144**. Multicast charging unit **144** updates the entry to charging database **146**. In one embodiment, the entry to charging database **146** appears as follows:

User Identification	Session Identification	Data Volume on Meter		Expiration Time of "Joined" Status
		Start Value	End Value	
21323421	finnkino 457286529 1453 172.10.20.212	V_1	V_2	t_4

Since the collection of data volume charges has stopped, multicast charging unit **144** closes the entry in charging database **146** for user terminal **170** using multicast session p , communicates the charging data to billing unit **151** for storage in billing database **152**, and deletes the entry in charging database **146**. Since the charging data is summarized, the total volume of data for user terminal **170** using multicast session p is $(V_2 - V_1)$. In

another embodiment, data volume meter 145 communicates the charging data to billing server 150 directly, without storing the charging data in charging database 146.

Referring to Figures 1B and 4B, if termination of the multicast session connection is implied from the passage of time, steps 1 through 7 are identical to steps 1 through 7 from the discussion of Figure 4A and determination of the data volume comprises:

1. Data volume meter 145 examining IP multicast data packets and maintaining a tally of the number of bytes of data received, for a given destination address and multicast session. Data volume meter 145 can either be co-located with multicast charging unit 144 or located on an upper layer of the multicast tree (e.g., on the gateway router where the multicast data enters the multicast network). In one embodiment, each last hop router may include a meter for measuring the multicast session routed to the last hop router. In another embodiment, the meter can be distributed across several access routers in the multicast network.
2. User terminal 170 sending a join message to group membership management 142 at time t_{X0} . If the join message takes the form $\text{join}(p, t_{S1}, 2)$, the user is requesting to join multicast session p , start the connection time charging at time t_{S1} , and pay for the service from the start time until time $t_3 = [(t_0 + m - t_{S1}) + (2 \times m)]$ where m is the duration of a time slot and t_0 is the start of a time slot. Calculation of the fee depends on the volume of data received by a given destination and multicast session between time t_{S1} and t_3 .
3. Multicast security client 173 receiving decryption key 165 from multicast security unit 143 before time t_{S1} . The multicast network informs user terminal 170 that time t_{D1} is the deadline for sending another join message. The offset w is defined by the network and represents the time interval between the deadline for receiving another join message and the end of a time slot.
4. At time t_{S1} , data volume meter 145 signals multicast charging unit 144 to add an entry to charging database 146 to store the data volume start value, V_1 , for user terminal 170 using multicast session p . In one embodiment, the entry to charging database 146 appears as follows:

User Identification	Session Identification	Data Volume on Meter		Expiration Time of "Joined" Status
		Start Value	End Value	
21323421	finnkino 457286529 1453 172.10.20.212	V_1	Null	t_3

5. From time t_{S1} until time t_3 , the multicast network is responsible for updating decryption key **165** for user terminal **170** whenever host membership in the multicast group changes. The updates to decryption key **165** occur during the offset interval w for each time slot. During the offset interval w , if the network determines that the status for a user will change from "joined" to "disjoined", the network updates decryption key **165**.
6. At time t_{X1} , where $t_{X1} < t_{D1}$, user terminal **170** extends the stop time by sending a second join message to specify a later stop time. If the second join message takes the form $\text{join}(p, t_3, 2)$, the user is requesting to extend the end time for the connection to multicast session p for 2 time slots after time t_3 . In one embodiment, the entry to charging database **146** appears as follows:

User Identification	Session Identification	Data Volume on Meter		Expiration Time of "Joined" Status
		Start Value	End Value	
21323421	finnkino 457286529 1453 172.10.20.212	V_1	Null	t_5

The multicast network informs user terminal **170** that time t_{D2} is the deadline for extending the expiration of the connection to multicast session p .

7. From time t_3 to time t_5 , the multicast network is responsible for updating decryption key **165** for user terminal **170** whenever host membership in the multicast group changes.
8. After time t_{D2} , if the network determines that the status for a user will change from "joined" to "disjoined", the network updates decryption key **165** and continues the multicast session for the user into the next time slot.

9. At time t_5 , collection of the data volume charges for user terminal 170 stops. Data volume meter 145 communicates the data volume end value, V_3 , for user terminal 170 using multicast session p to multicast charging unit 144. Multicast charging unit 144 updates the entry to charging database 146. In one embodiment, the entry to charging database 146 appears as follows:

User Identification	Session Identification	Data Volume on Meter		Expiration Time of "Joined" Status
		Start Value	End Value	
21323421	finnkino 457286529 1453 172.10.20.212	V_1	V_3	t_4

Since the collection of data volume charges has stopped, multicast charging unit 144 closes the entry in charging database 146 for user terminal 170 using multicast session p , communicates the charging data to billing unit 151 for storage in billing database 152, and deletes the entry in charging database 146. Since the charging data is summarized, the total volume of data for user terminal 170 using multicast session p is $(V_3 - V_1)$. In another embodiment, data volume meter 145 communicates the charging data to billing server 150 directly, without storing the charging data in charging database 146.

Although the embodiments disclosed herein describe a fully functioning system, method, and computer program product for calculating a cost of receiving multicast data from a multicast session, the reader should understand that other equivalent embodiments exist. Since numerous modifications and variations will occur to those who review this disclosure, the system, method, and computer program product for calculating a cost of receiving multicast data from a multicast session is not limited to the exact construction and operation illustrated and disclosed herein. Accordingly, this disclosure intends all suitable modifications and equivalents to fall within the scope of the claims.

We claim:

1. A method for calculating a cost of receiving multicast data from a multicast session, a multicast network including at least one multicast service, each multicast service including at least one multicast session, comprising:
 - 5 receiving a request to establish a connection to the multicast session, the request including a start time for the connection and an end time for the connection;
storing the start time for the connection and the end time for the connection; and
after termination of the connection, calculating the cost of receiving the multicast data.
 2. The method of claim 1, further comprising:
 - 10 receiving a subsequent request to extend the connection, the subsequent request specifying a new end time for the connection; and
storing the new end time for the connection.
 3. The method of claim 1, further comprising:
 - 15 receiving a subsequent request to terminate the connection, the subsequent request specifying a new end time that precedes the end time for the connection; and
storing the new end time for the connection.
 4. The method of claim 1, wherein the storing of the start time for the connection and the end time for the connection is to a database.
 5. The method of claim 1, wherein the calculating of the cost further comprises:
 - 20 computing a charge for receiving the multicast data;
storing the charge; and
computing the cost by multiplying the charge by a fee for the multicast service associated with the multicast session.
 6. The method of claim 5, wherein the computing of the charge further comprises:

computing an elapsed connection time by subtracting the start time for the connection from the end time for the connection.

7. The method of claim 5, wherein the computing of the charge further comprises:
computing a volume of data received over the connection from the start time for the
5 connection to the end time for the connection.
8. The method of claim 5, wherein the storing of the charge is to a database.
9. The method of claim 1, wherein time is divided into evenly spaced time slots, and wherein the start time for the connection the end time for the connection can only occur at the end of a time slot.
- 10 10. The method of claim 9, wherein the end time for the connection in the request is specified as a discrete number of time slots.
11. A system for calculating a cost of receiving multicast data from a multicast session, a multicast network including at least one multicast service, each multicast service including at least one multicast session, comprising:
15 a memory device; and
a processor disposed in communication with the memory device, the processor configured to:
receive a request to establish a connection to the multicast session, the request including a start time for the connection and an end time for the connection;
20 store the start time for the connection and the end time for the connection; and
after termination of the connection, calculate the cost of receiving the multicast data.
12. The system of claim 11, wherein the processor is further configured to:
receive a subsequent request to extend the connection, the subsequent request specifying

a new end time for the connection; and
store the new end time for the connection.

13. The system of claim 11, wherein the processor is further configured to:
receive a subsequent request to terminate the connection, the subsequent request
5 specifying a new end time that precedes the end time for the connection; and
store the new end time for the connection.
14. The system of claim 11, wherein the processor stores the start time for the connection
and the end time for the connection to a database.
15. The system of claim 11, wherein to calculate the cost, the processor is further configured
10 to:
compute a charge for receiving the multicast data;
store the charge; and
compute the cost by multiplying the charge by a fee for the multicast service associated
with the multicast session.
- 15 16. The system of claim 15, wherein to compute the charge, the processor is further
configured to:
compute an elapsed connection time by subtracting the start time for the connection
from the end time for the connection.
17. The system of claim 15, wherein to compute the charge, the processor is further
20 configured to:
compute a volume of data received over the connection from the start time for the
connection to the end time for the connection.
18. The system of claim 15, wherein the processor stores the charge to a database.

19. The system of claim 11, wherein time is divided into evenly spaced time slots, and wherein the start time for the connection the end time for the connection can only occur at the end of a time slot.

20. The system of claim 19, wherein the end time for the connection in the request is
5 specified as a discrete number of time slots.

21. A computer program product for calculating a cost of receiving multicast data from a multicast session, a multicast network including at least one multicast service, each multicast service including at least one multicast session, comprising:

a computer readable medium;

10 program code in said computer readable medium for receiving a request to establish a connection to the multicast session, the request including a start time for the connection and an end time for the connection;

program code in said computer readable medium for storing the start time for the connection and the end time for the connection; and

15 after termination of the connection, program code in said computer readable medium for calculating the cost of receiving the multicast data.

22. The computer readable medium of claim 21, further comprising:

program code in said computer readable medium for receiving a subsequent request to extend the connection, the subsequent request specifying a new end time for the connection; and

20 program code in said computer readable medium for storing the new end time for the connection.

23. The computer readable medium of claim 21, further comprising:

25 program code in said computer readable medium for receiving a subsequent request to terminate the connection, the subsequent request specifying a new end time that precedes the end time for the connection; and

program code in said computer readable medium for storing the new end time for the

connection.

24. The computer readable medium of claim 21, wherein the storing of the start time for the connection and the end time for the connection is to a database.

25. The computer readable medium of claim 21, wherein the program code in said computer
5 readable medium for calculating the cost further comprises:

program code in said computer readable medium for computing a charge for receiving
the multicast data;

program code in said computer readable medium for storing the charge; and

10 program code in said computer readable medium for computing the cost by multiplying
the charge by a fee for the multicast service associated with the multicast session.

26. The computer readable medium of claim 25, wherein the program code in said computer
readable medium for computing the charge further comprises:

program code in said computer readable medium for computing an elapsed connection
time by subtracting the start time for the connection from the end time for the connection.

15 27. The computer readable medium of claim 25, wherein the program code in said computer
readable medium for computing the charge further comprises:

program code in said computer readable medium for computing a volume of data
received over the connection from the start time for the connection to the end time for the
connection.

20 28. The computer readable medium of claim 25, wherein the storing of the charge is to a
database.

29. The computer readable medium of claim 21, wherein time is divided into evenly spaced
time slots, and wherein the start time for the connection the end time for the connection can only
occur at the end of a time slot.

30. The computer readable medium of claim 29, wherein the end time for the connection in the request is specified as a discrete number of time slots.

31. A system for calculating a cost of receiving multicast data from a multicast session, a multicast network including at least one multicast service, each multicast service including at least one multicast session, comprising:

a collection device comprising:

a collection memory device; and

a collection processor disposed in communication with the collection memory device, the collection processor configured to:

10 receive a request to establish a connection to the multicast session, the request including a start time for the connection and an end time for the connection;

store the start time for the connection and the end time for the connection; and

15 after termination of the connection, calculate the cost of receiving the multicast data; and

an interface device comprising:

an interface memory device; and

20 an interface processor disposed in communication with the interface memory device, the interface processor configured to:

configure the collection device; and

display the cost of receiving the multicast data.

32. The system of claim 31, wherein the collection processor is further configured to: receive a subsequent request to extend the connection that specifies a new end time for the connection; and

25 store the new end time for the connection

33. The system of claim 31, wherein the collection processor is further configured to:
receive a subsequent request to terminate the connection that specifies a new end time
for the connection; and
store the new end time for the connection.
- 5 34. The system of claim 31, wherein the collection processor stores the start time for the
connection and the end time for the connection to a database.
35. The system of claim 31, wherein to calculate the cost, the collection processor is further
configured to:
compute a charge for receiving the multicast data;
10 store the charge; and
compute the cost by multiplying the charge by a fee for the multicast service associated
with the multicast session.
36. The system of claim 35, wherein to compute the charge, the collection processor is
further configured to:
15 compute an elapsed connection time by subtracting the start time for the connection
from the end time for the connection.
37. The system of claim 35, wherein to compute the charge, the collection processor is
further configured to:
compute a volume of data received over the connection from the start time for the
20 connection to the end time for the connection.
38. The system of claim 35, wherein the collection processor stores the charge to a database.
39. The system of claim 31, wherein time is divided into evenly spaced time slots, and
wherein the start time for the connection the end time for the connection can only occur at the
end of a time slot.

40. The system of claim 39, wherein the end time for the connection in the request is specified as a discrete number of time slots.

41. An apparatus for calculating a cost of receiving multicast data from a multicast session, a multicast network including at least one multicast service, each multicast service including at least one multicast session, comprising:

a computer readable readable medium;

program code in said computer readable medium for sending a request to establish a connection to the multicast session, the request including a start time for the connection and an end time for the connection;

10 program code in said computer readable medium for sending a first subsequent request after the request, the first subsequent request including a new end time for the connection, the new end time being later than the end time; and

15 program code in said computer readable medium for sending a second subsequent request after the first subsequent request, the second subsequent request including an earlier end time for the connection, the earlier end time after the end time and before the new end time.

42. The apparatus of claim 41, further comprising:

program code in said computer readable medium for determining a request time interval; wherein sending the request, sending the first subsequent request, and sending the

20 second subsequent request only occur at a time that is a multiple of the request time interval from the start time.

Figure 1A

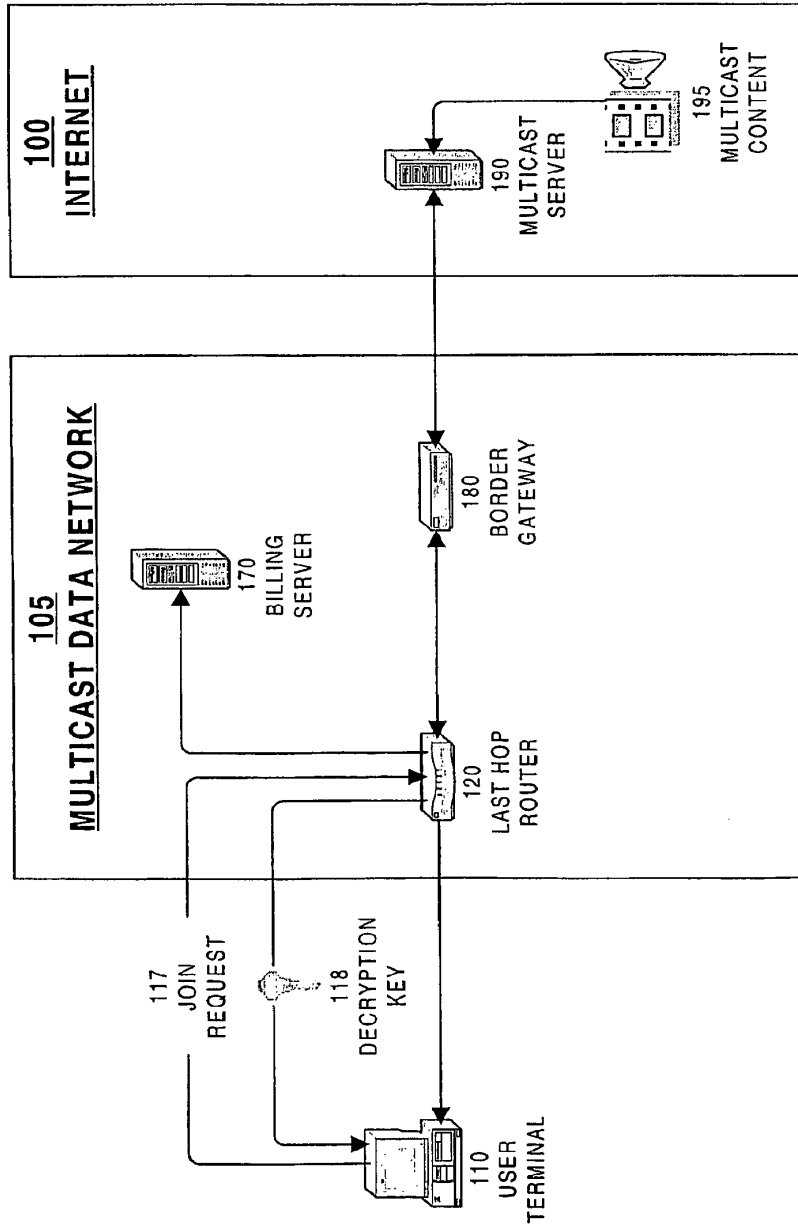

Figure 1B

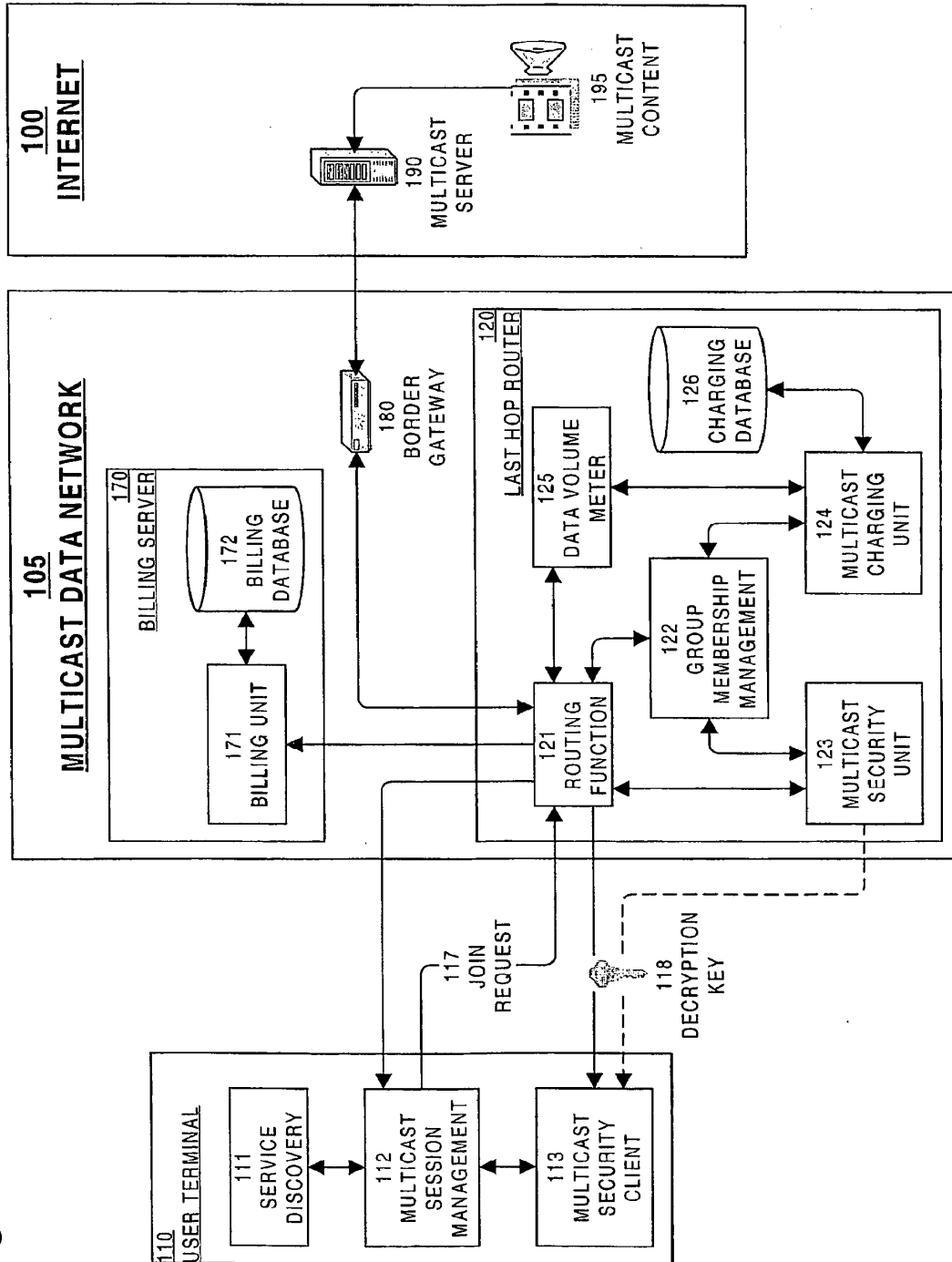

Figure 1C

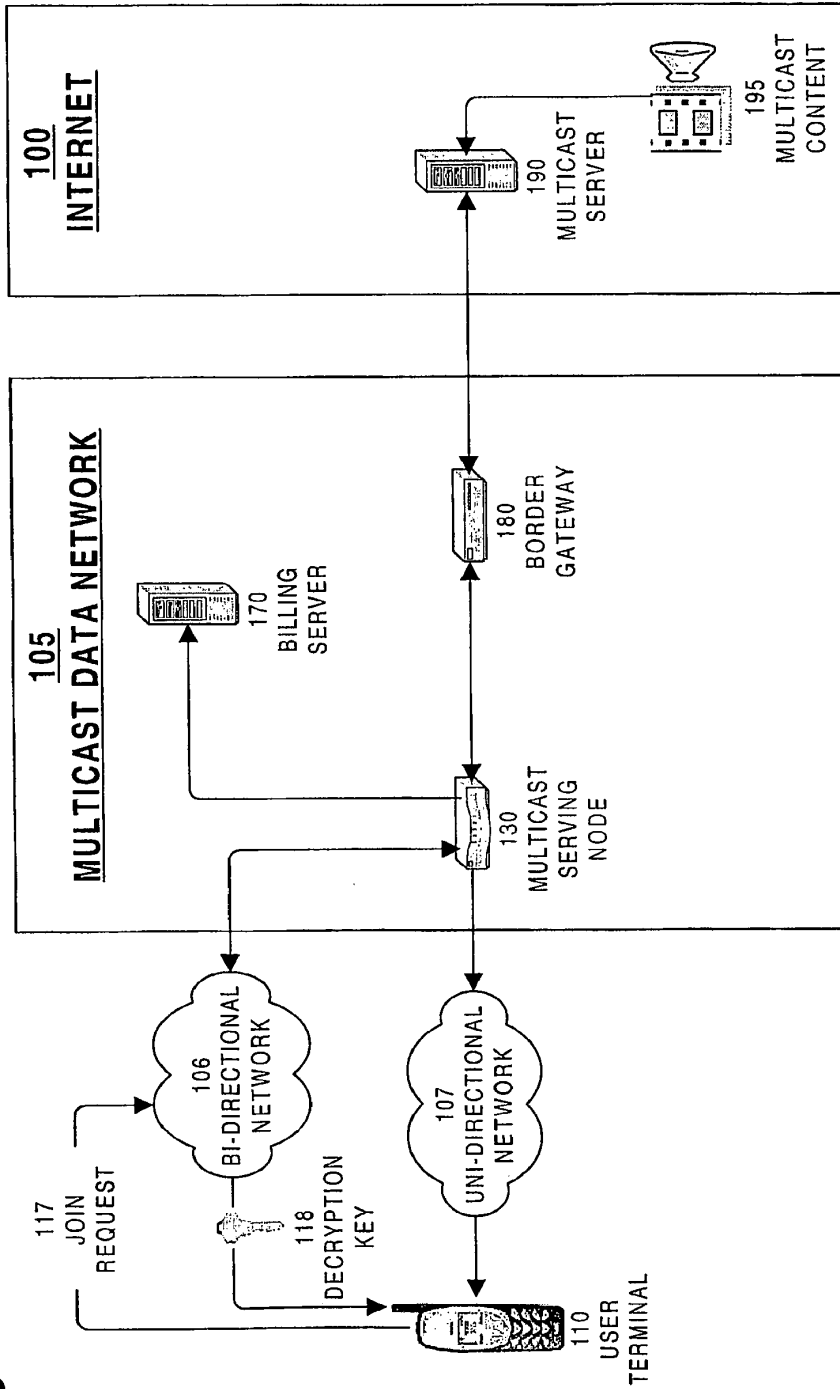

Figure 1D

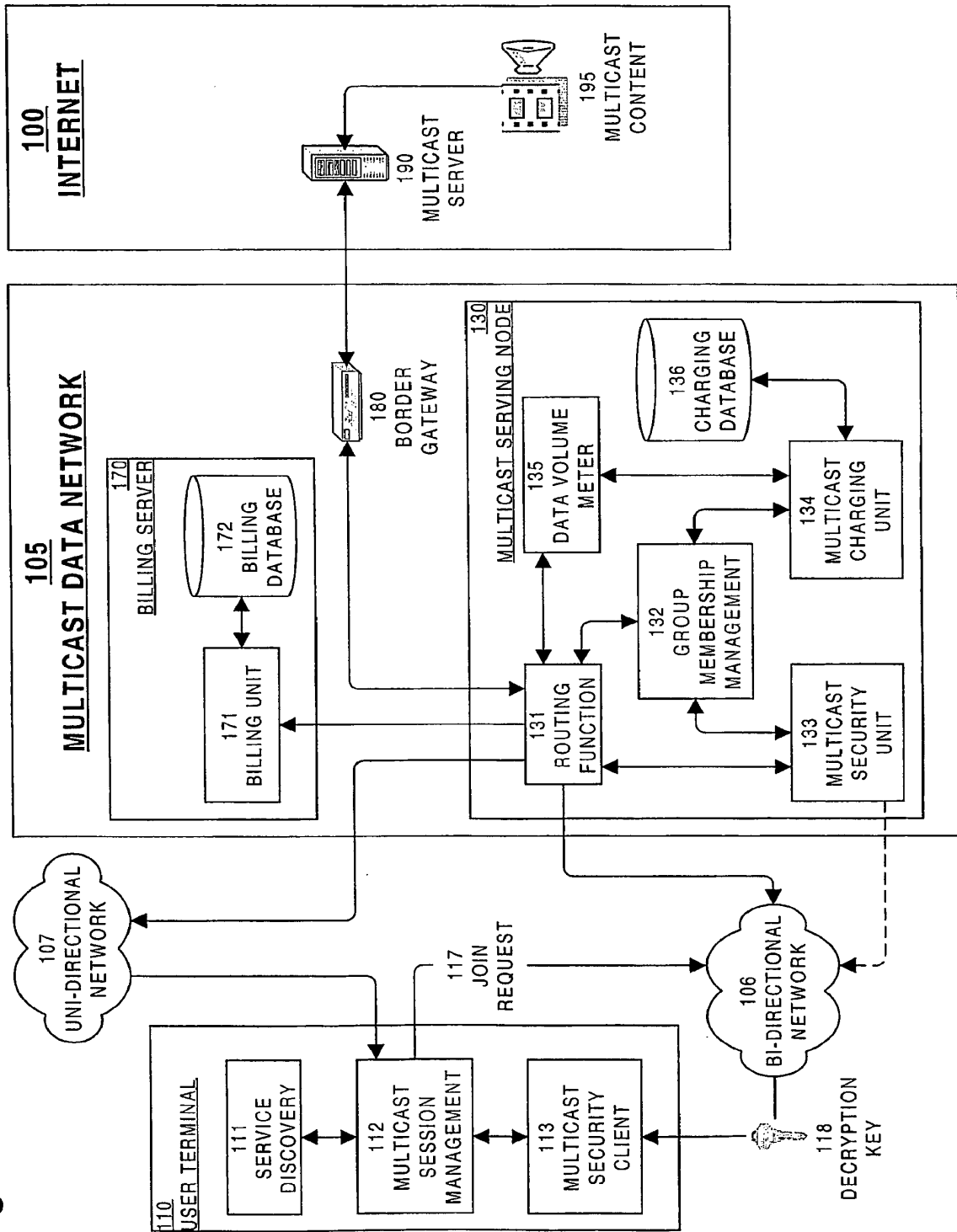

Figure 1E

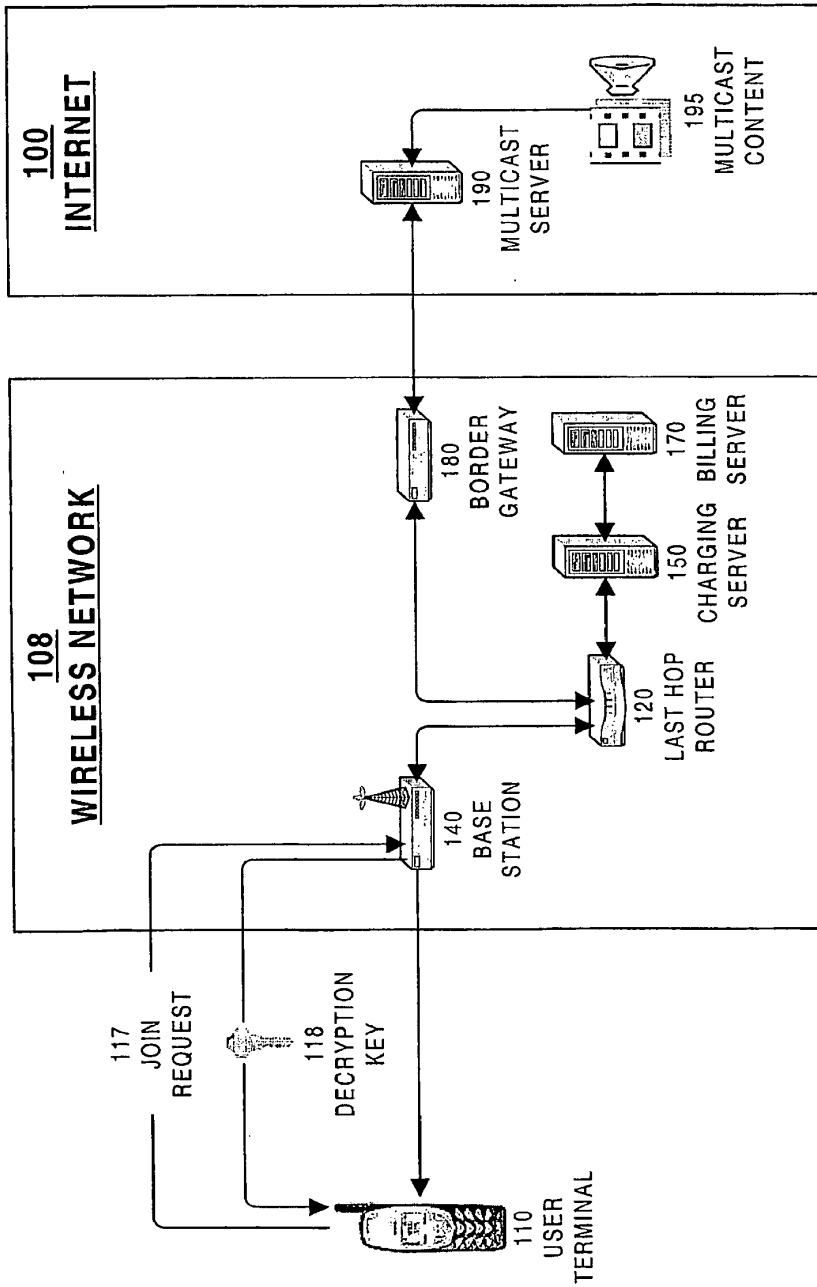

Figure 1F

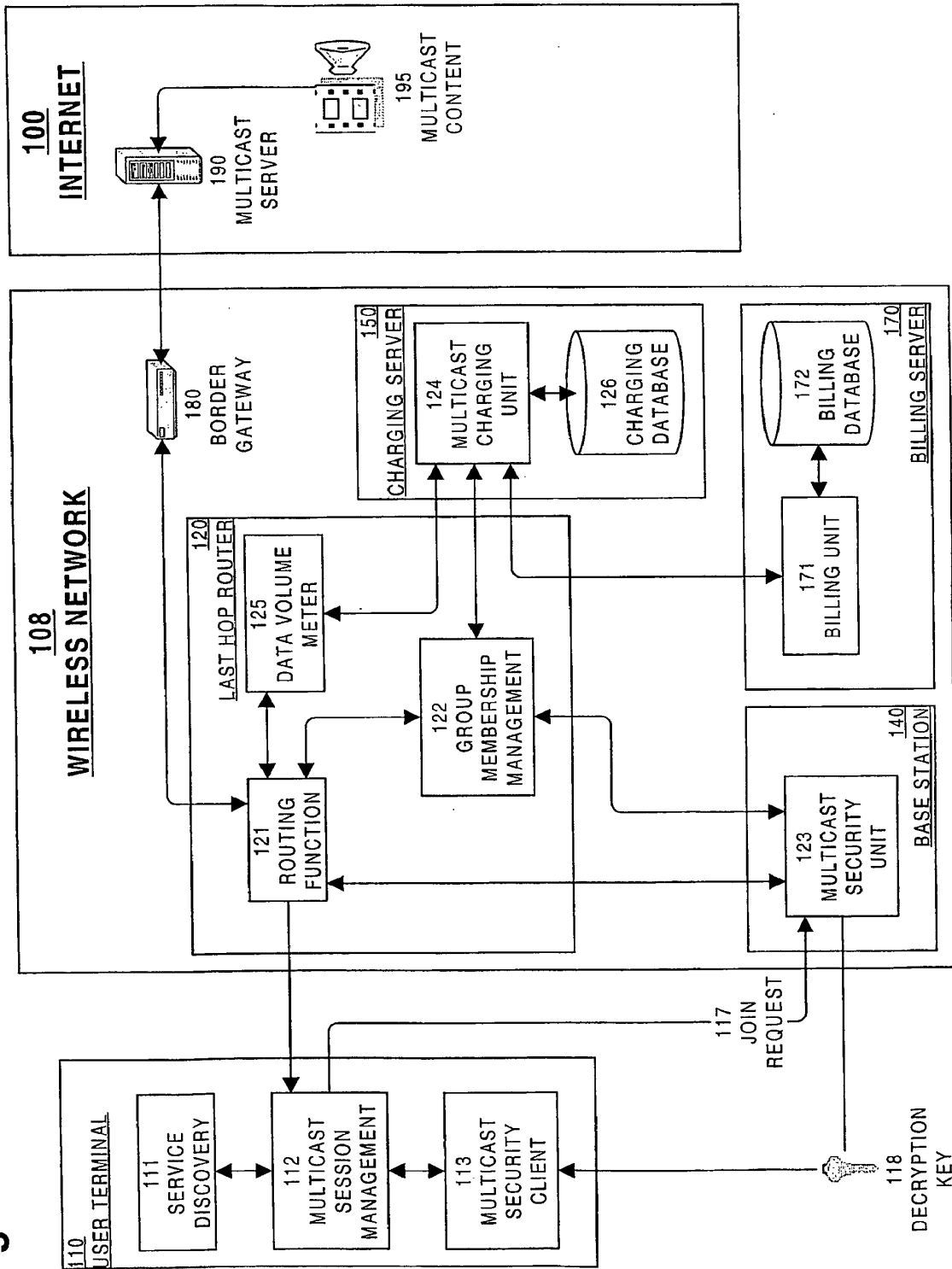

Figure 1G

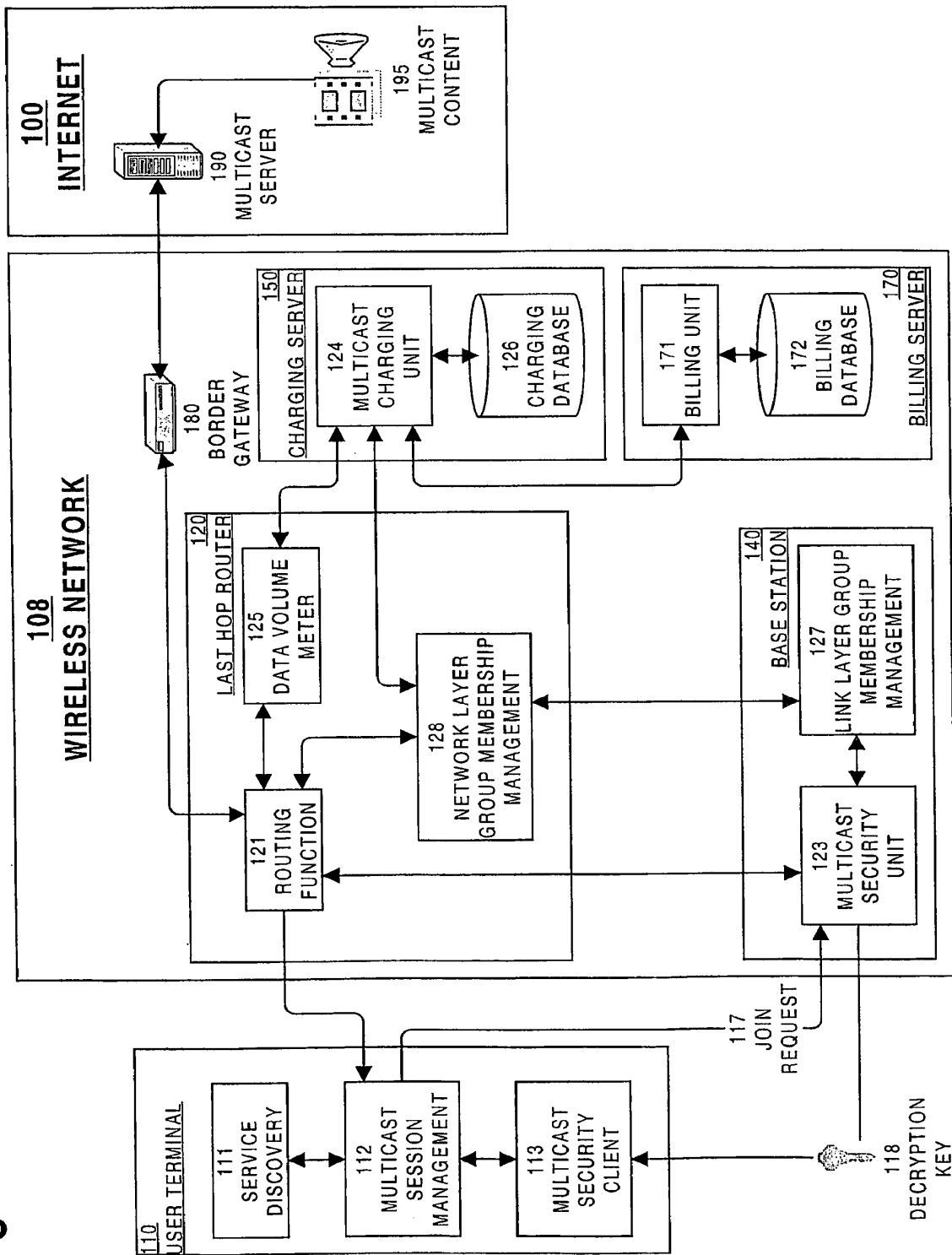

Figure 2A

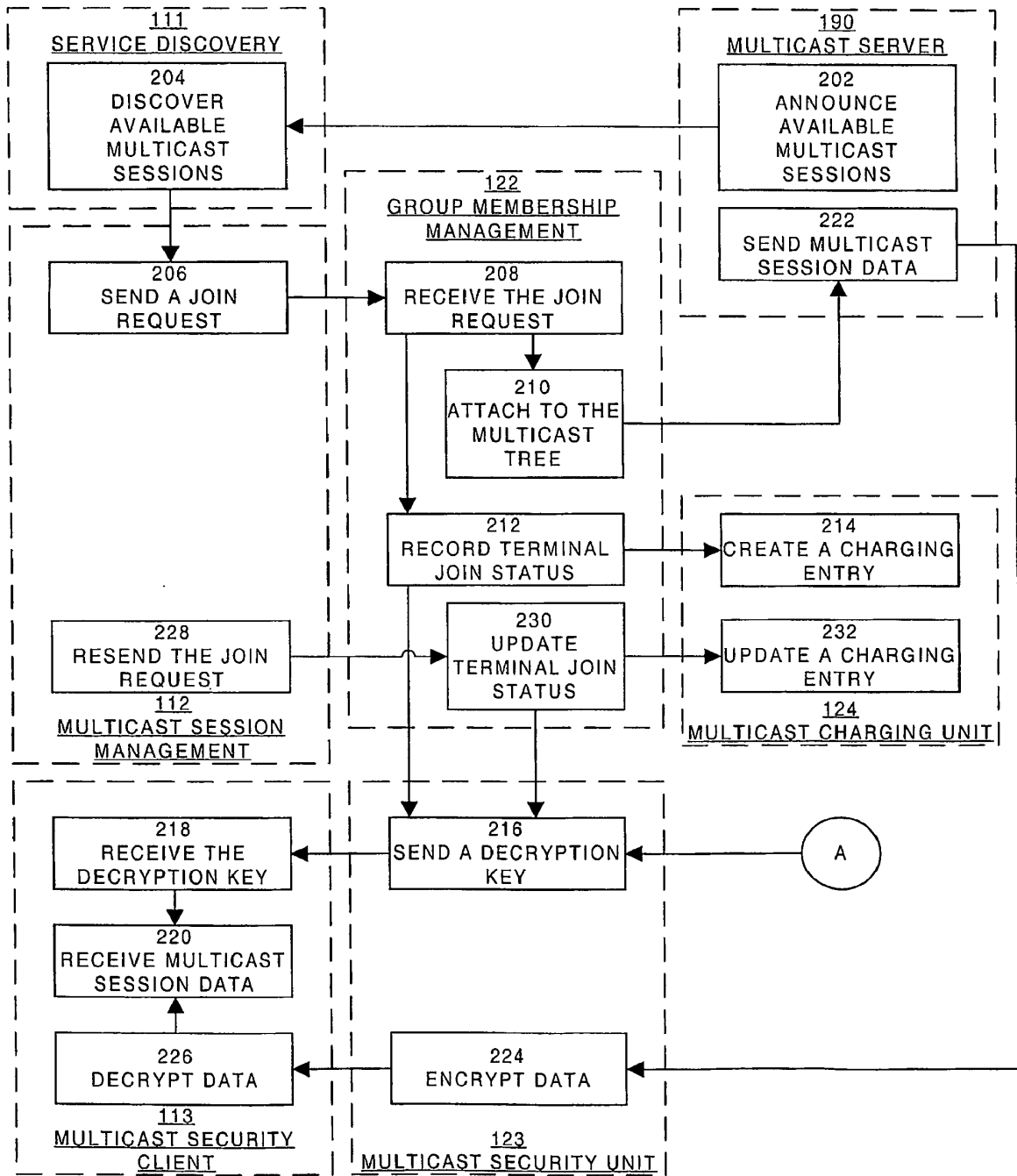

Figure 2B

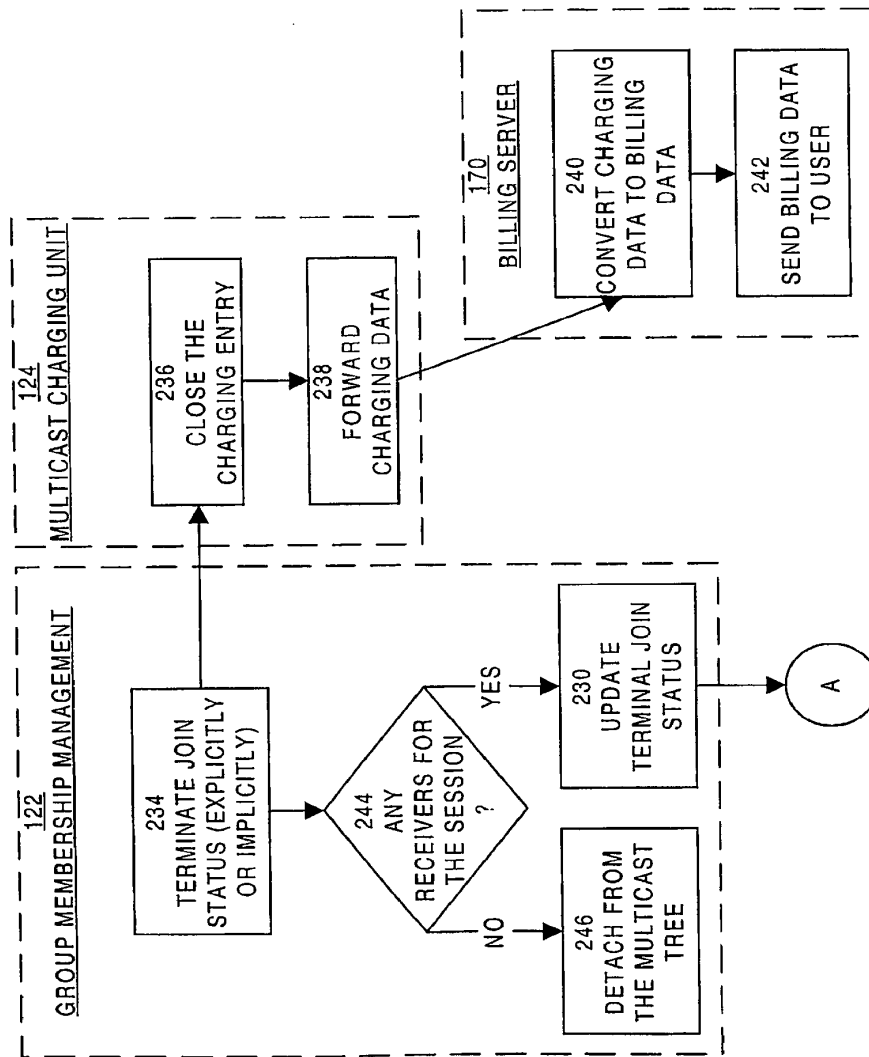

Figure 2C

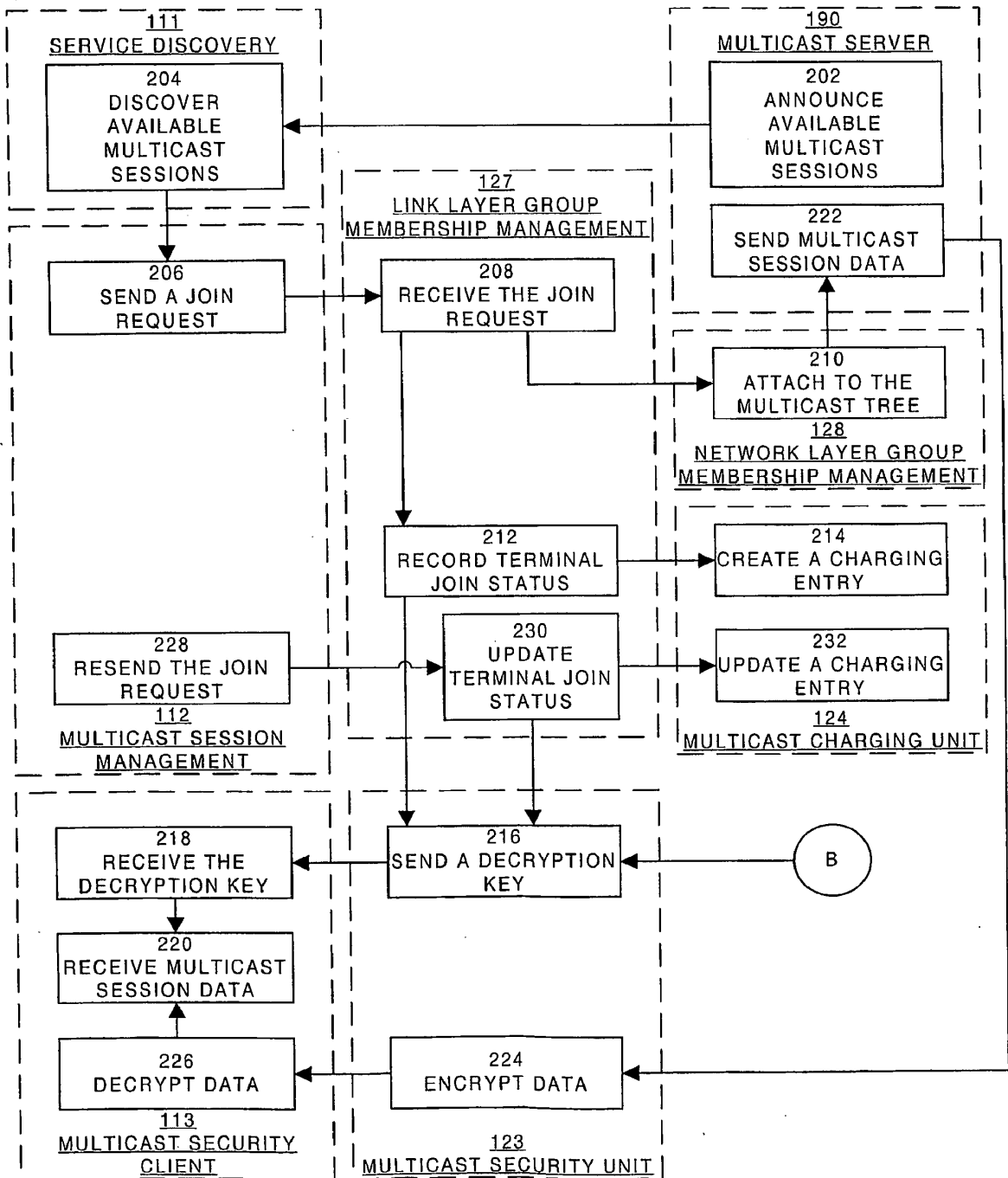

Figure 2D

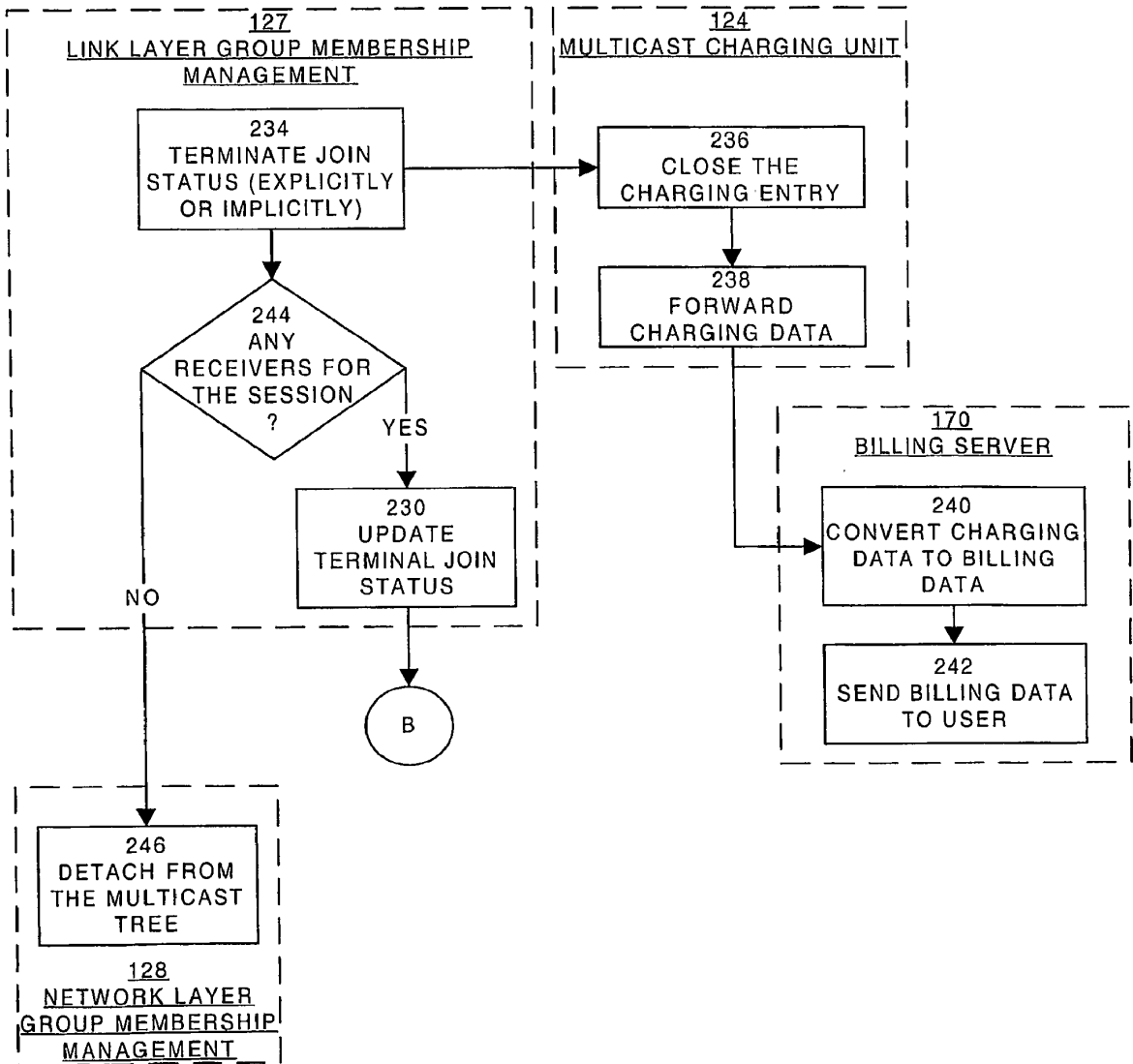

Figure 3A

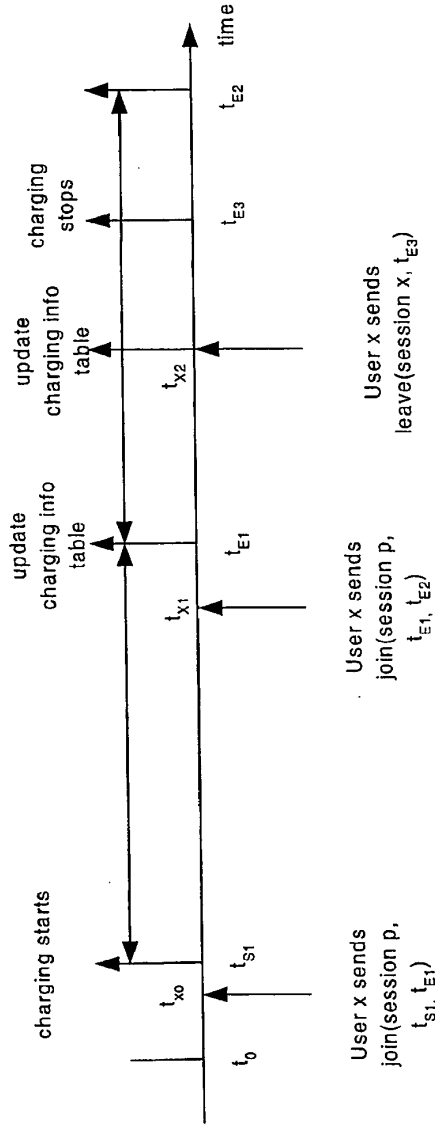

Figure 3B

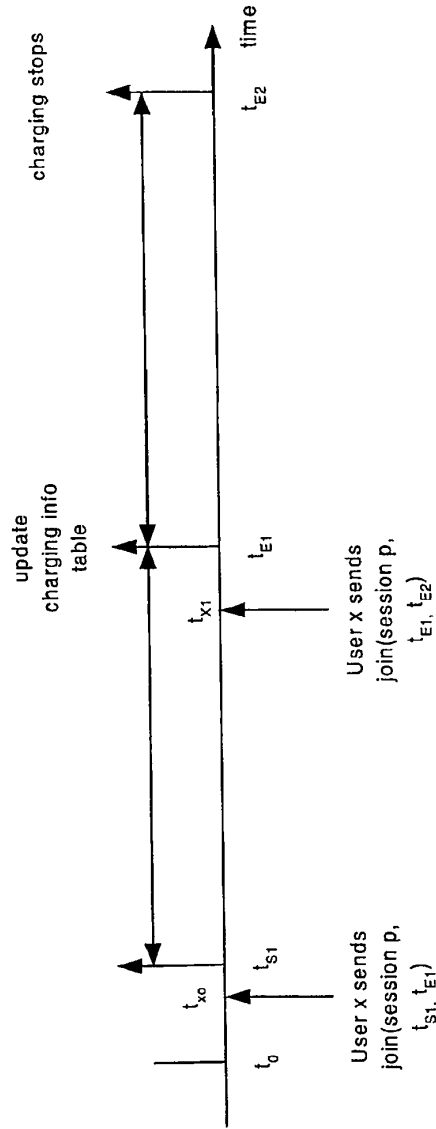

Figure 3C

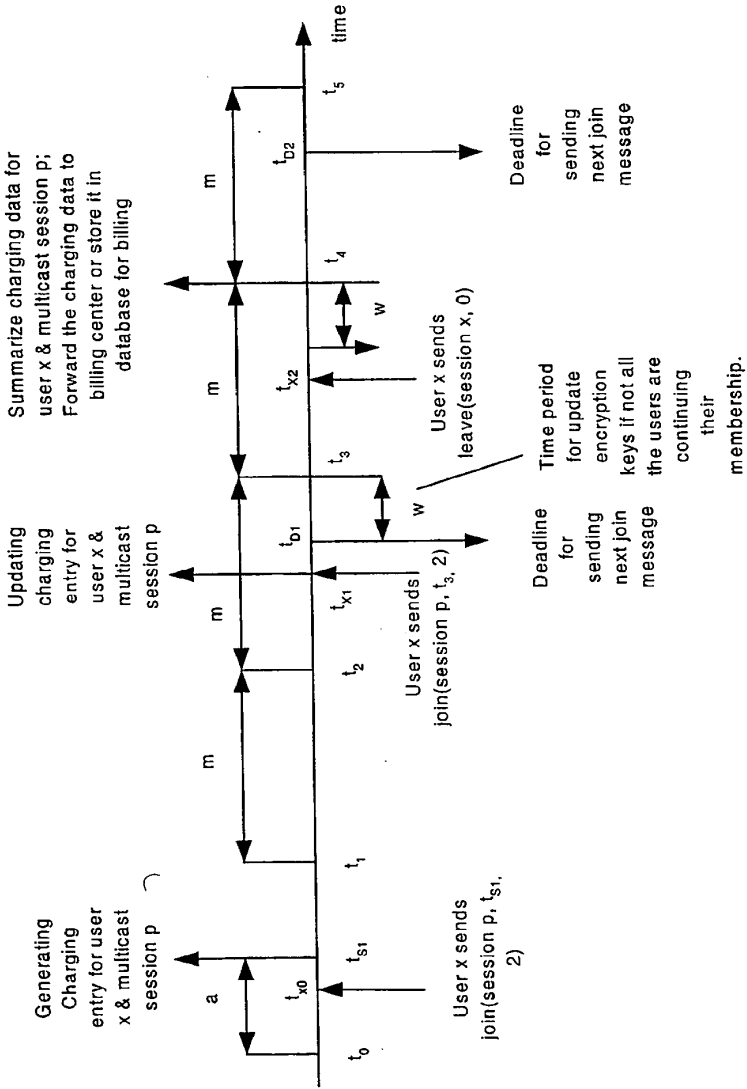

Figure 3D

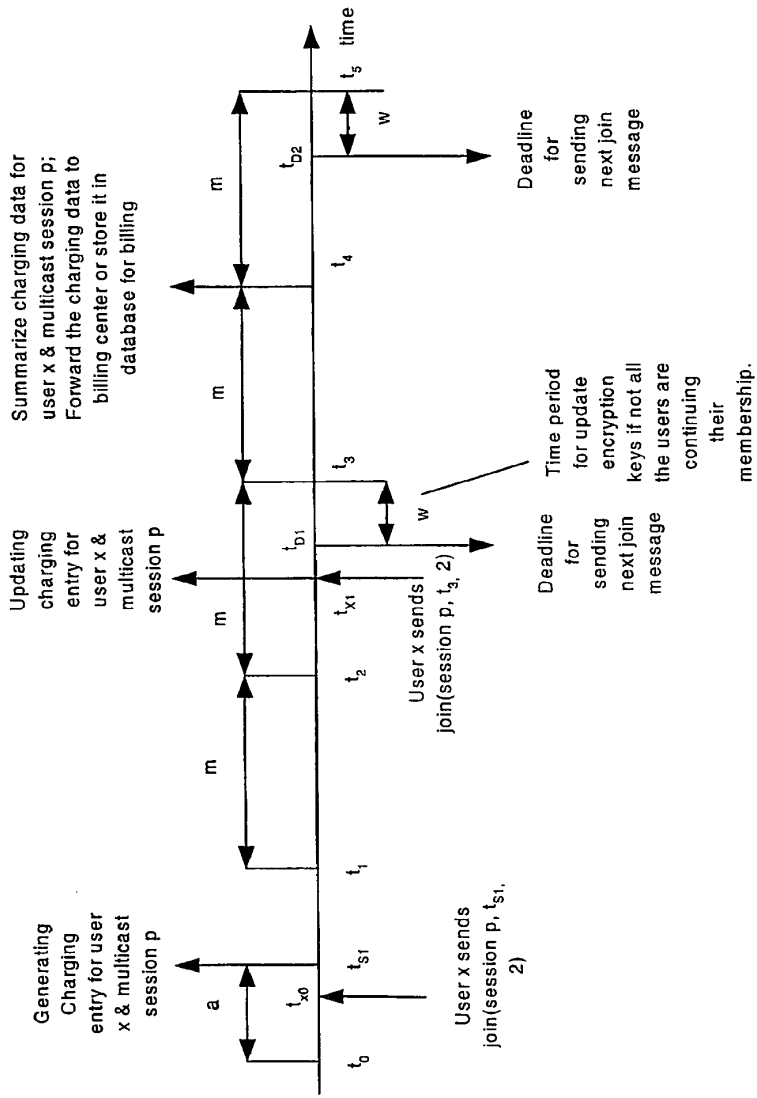

Figure 4A

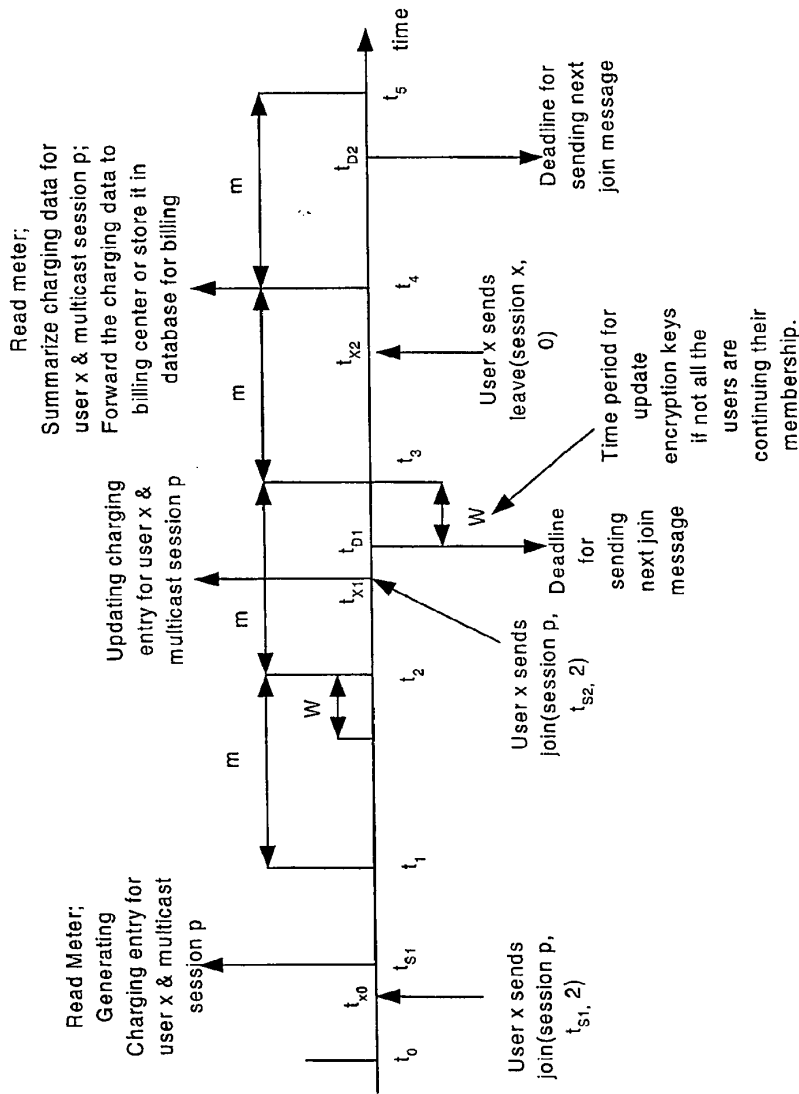
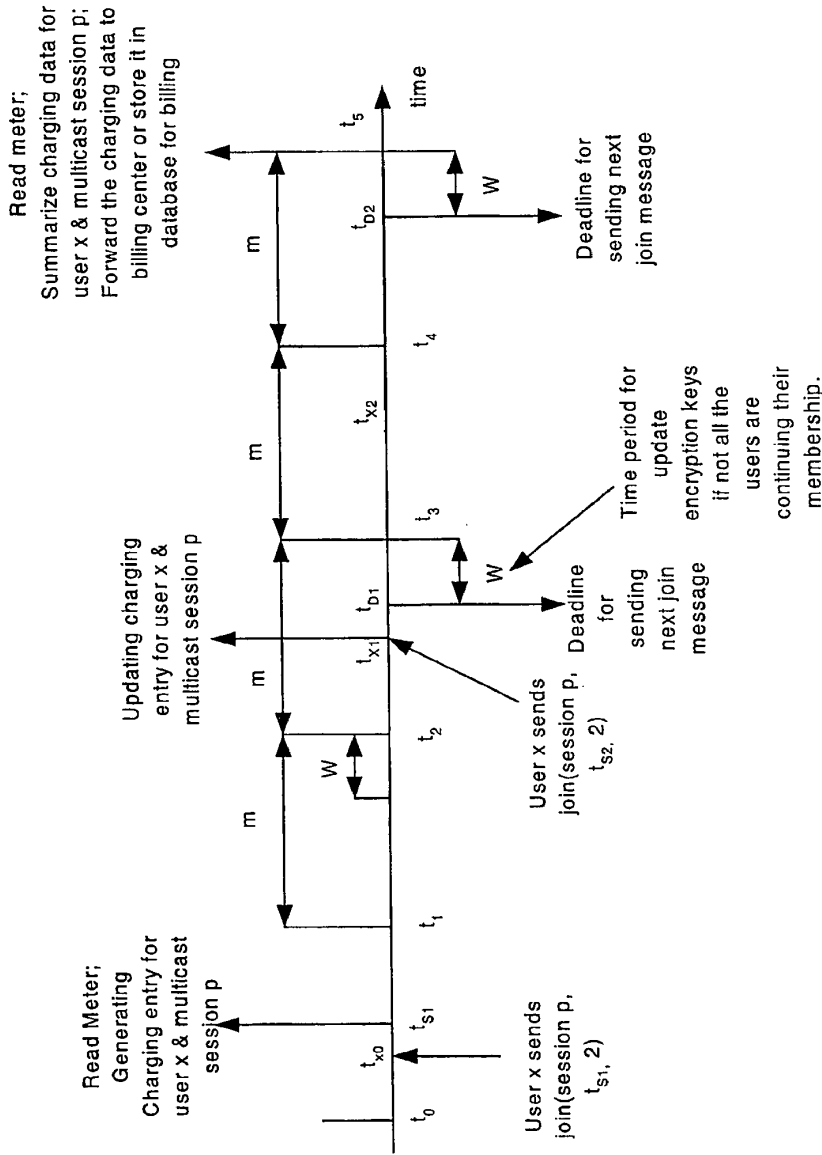

Figure 4B



(12) INTERNATIONAL APPLICATION PUBLISHED UNDER THE PATENT COOPERATION TREATY (PCT)

(19) World Intellectual Property
Organization
International Bureau



(43) International Publication Date
28 August 2003 (28.08.2003)

PCT

(10) International Publication Number
WO 2003/071392 A3

- (51) International Patent Classification⁷: **G06F 17/60** (72) Inventors: XU, Lin; Pyrypolku 11, FIN-33880 Lempälää (FI). LEINONEN, Jarno; Kiskentänkatu 24 B 13, FIN-33230 Tampere (FI).
- (21) International Application Number: PCT/US2003/004986 (74) Agent: WASZKIEWICZ, Kenneth, P.; c/o Morgan & Finnegan, LLP, 345 Park Avenue, New York, NY 10154 (US).
- (22) International Filing Date: 20 February 2003 (20.02.2003)
- (25) Filing Language: English (81) Designated State (national): CN.
- (26) Publication Language: English Published: — with international search report
- (30) Priority Data: 10/077,780 20 February 2002 (20.02.2002) US (88) Date of publication of the international search report: 25 March 2004
- (71) Applicant: NOKIA CORPORATION [FI/FI]; Keilalahdentie 4, FIN-FIN-02150 Espoo (FI). For two-letter codes and other abbreviations, refer to the "Guidance Notes on Codes and Abbreviations" appearing at the beginning of each regular issue of the PCT Gazette.

(54) Title: CHARGING MECHANISM FOR MULTICASTING

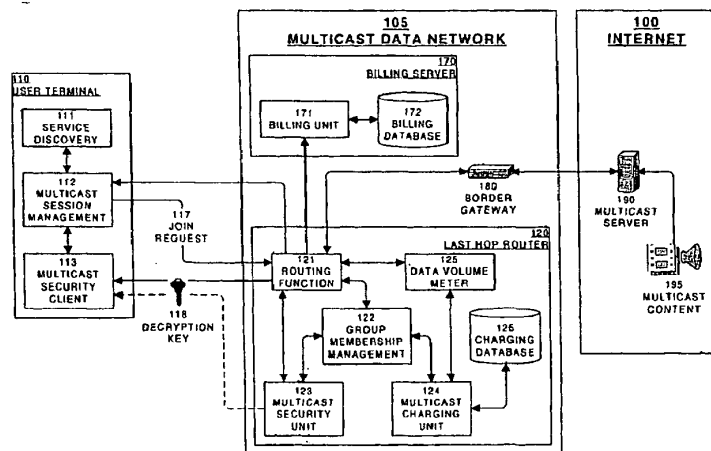

(57) Abstract: An apparatus (120, 170, 180) for calculating a cost of receiving multicast data from a multicast session. A multicast network (105) includes at least one multicast service (190, 195), each multicast service (190, 195) including at least one multicast session. The apparatus (120, 170, 180) receives a request (117) to establish a connection to the multicast session, stores a start time for the connection and an end time for the connection and, after termination of the connection, calculates the cost of receiving the multicast data. The apparatus can receive a subsequent request (117) to extend the connection, the subsequent request (117) specifying a new end time for the connection, and store the new end time for the connection. Alternatively, the apparatus can receive a subsequent request (117) to terminate the connection, the subsequent request specifying a new end time that precedes the end time for the connection, and store the new end time for the connection.

WO 2003/071392 A3

INTERNATIONAL SEARCH REPORT

International application No.

PCT/US03/04986

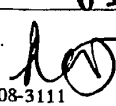
A. CLASSIFICATION OF SUBJECT MATTER		
IPC(7) : G06F 17/60 US CL : 705/418; 377/16; 705/400		
According to International Patent Classification (IPC) or to both national classification and IPC		
B. FIELDS SEARCHED		
Minimum documentation searched (classification system followed by classification symbols) U.S. : 377,15 16; 705/400, 417, 418		
Documentation searched other than minimum documentation to the extent that such documents are included in the fields searched None		
Electronic data base consulted during the international search (name of data base and, where practicable, search terms used) None		
C. DOCUMENTS CONSIDERED TO BE RELEVANT		
Category *	Citation of document, with indication, where appropriate, of the relevant passages	Relevant to claim No.
A	DE 4331432 A1 (LAUDAHN) 16 March 1995 (16.03.1995), see abstract.	1-42
A	PCNetter: "SPECIAL REPORT: Cisco Systems' Universal Access Servers", 01 April 1996, vol. 11, no. 4, retrieved from DIALOG, DIALOG No.: 03065139, see entire	1-42
X	US 5,606,497 A (CRAMER et al) 25 February 1997 (25.02.1997), see abstract.	1-6, 8-16, 18-26, 28-36 & 38-42
---		-----
A		7, 17, 27 & 37
X	US 6,011,841 A (ISONO) 04 January 2000 (04.01.2000), see abstract.	1-6, 8-16, 18-26, 28-36 & 38-42
---		-----
A		7, 17, 27 & 37
X	US 2002/0002470 A1 (ARIA) 03 January 2002 (03.01.2002), see abstract.	1-42
A, P	US 6,363,137 B1 (NAKAO et al) 26 March 2002 (26.03.2002), see abstract.	1-42
<input checked="" type="checkbox"/> Further documents are listed in the continuation of Box C. <input type="checkbox"/> See patent family annex.		
* Special categories of cited documents:		
"A"	document defining the general state of the art which is not considered to be of particular relevance	"T" later document published after the international filing date or priority date and not in conflict with the application but cited to understand the principle or theory underlying the invention
"B"	earlier application or patent published on or after the international filing date	"X" document of particular relevance; the claimed invention cannot be considered novel or cannot be considered to involve an inventive step when the document is taken alone
"L"	document which may throw doubts on priority claim(s) or which is cited to establish the publication date of another citation or other special reason (as specified)	"Y" document of particular relevance; the claimed invention cannot be considered to involve an inventive step when the document is combined with one or more other such documents, such combination being obvious to a person skilled in the art
"O"	document referring to an oral disclosure, use, exhibition or other means	"&" document member of the same patent family
"P"	document published prior to the international filing date but later than the priority date claimed	
Date of the actual completion of the international search 08 September 2003 (08.09.2003)		Date of mailing of the international search report 01 OCT 2003
Name and mailing address of the ISA/US Mail Stop PCT, Attn: ISA/US Commissioner for Patents P.O. Box 1450 Alexandria, Virginia 22313-1450 Facsimile No. (703)305-3230		Authorized officer Edward R. Cosimano  Telephone No. (703) 308-3111

Form PCT/ISA/210 (second sheet) (July 1998)

INTERNATIONAL SEARCH REPORT

PCT/US03/04986

C. (Continuation) DOCUMENTS CONSIDERED TO BE RELEVANT

Category *	Citation of document, with indication, where appropriate, of the relevant passages	Relevant to claim No.
X,P --- A,P	US 2002/0062289 A1 (KONDO) 23 May 2002 (23.05.2002), see abstract.	1-6, 8-16, 18-26, 28-36 & 38-42
		----- 7, 17, 27 & 37
X,P	US 2002/0077981 A1 (TAKATORI et al) 20 June 2002 (20.06.2002), see abstract.	1-42
X,P --- A,P	US 6,424,704 B1 (LEE) 23 July 2002 (23.07.2002), see abstract.	1-6, 8-16, 18-26, 28-36 & 38-42
		----- 7, 17, 27 & 37

Form PCT/ISA/210 (second sheet) (July 1998)

(12) INTERNATIONAL APPLICATION PUBLISHED UNDER THE PATENT COOPERATION TREATY (PCT)

(19) World Intellectual Property Organization
International Bureau



(43) International Publication Date
18 September 2003 (18.09.2003)

PCT

(10) International Publication Number
WO 03/077063 A2

- (51) International Patent Classification⁷: **G06F** Street, Portland, OR 97232 (US). **ROHOLT, Grant** [US/US]; 2735 NE 18th Avenue, Portland, OR 97212 (US).
- (21) International Application Number: PCT/US03/06526
- (22) International Filing Date: 4 March 2003 (04.03.2003) (74) Agent: **STOLOWITZ, Micah, D.**; Stoel Rives LLP, 900 SW Fifth Avenue, Suite 2600, Portland, OR 97204-1268 (US).
- (25) Filing Language: English
- (26) Publication Language: English (81) Designated States (*national*): AE, AG, AL, AM, AT, AU, AZ, BA, BB, BG, BR, BY, BZ, CA, CH, CN, CO, CR, CU, CZ, DE, DK, DM, DZ, EC, EE, ES, FI, GB, GD, GE, GH, GM, HR, HU, ID, IL, IN, IS, JP, KE, KG, KP, KR, KZ, LC, LK, LR, LS, LT, LU, LV, MA, MD, MG, MK, MN, MW, MX, MZ, NO, NZ, OM, PH, PL, PT, RO, RU, SC, SD, SE, SG, SK, SL, TJ, TM, TN, TR, TT, TZ, UA, UG, US, UZ, VC, VN, YU, ZA, ZM, ZW.
- (30) Priority Data: 60/361,647 4 March 2002 (04.03.2002) US
- (71) Applicant (*for all designated States except US*): **SWAN ISLAND NETWORKS, INC.** [US/US]; 55 SW Yamhill, Suite 400, Portland, OR 97204 (US).
- (72) Inventors; and
- (75) Inventors/Applicants (*for US only*): **HEELAN, Jake** [US/US]; 3566 SW Council Crest Drive, Portland, OR 97239 (US). **JENNINGS, Charles** [US/US]; 11553 NW Damascus, Portland, OR 97229 (US). **O'DELL, Pete** [US/US]; 7925 NW Blue Pointe Lane, Portland, OR 97229 (US). **MCMAHON, Ryan** [US/US]; 3306 NE Pacific
- (84) Designated States (*regional*): ARIPO patent (GH, GM, KE, LS, MW, MZ, SD, SL, SZ, TZ, UG, ZM, ZW), Eurasian patent (AM, AZ, BY, KG, KZ, MD, RU, TJ, TM), European patent (AT, BE, BG, CH, CY, CZ, DE, DK, EE, ES, FI, FR, GB, GR, HU, IE, IT, LU, MC, NL, PT, RO, SE, SI, SK, TR), OAPI patent (BF, BJ, CF, CG, CI, CM, GA, GN, GQ, GW, ML, MR, NE, SN, TD, TG).

[Continued on next page]

(54) Title: EMERGENCY INFORMATION MANAGEMENT SYSTEM

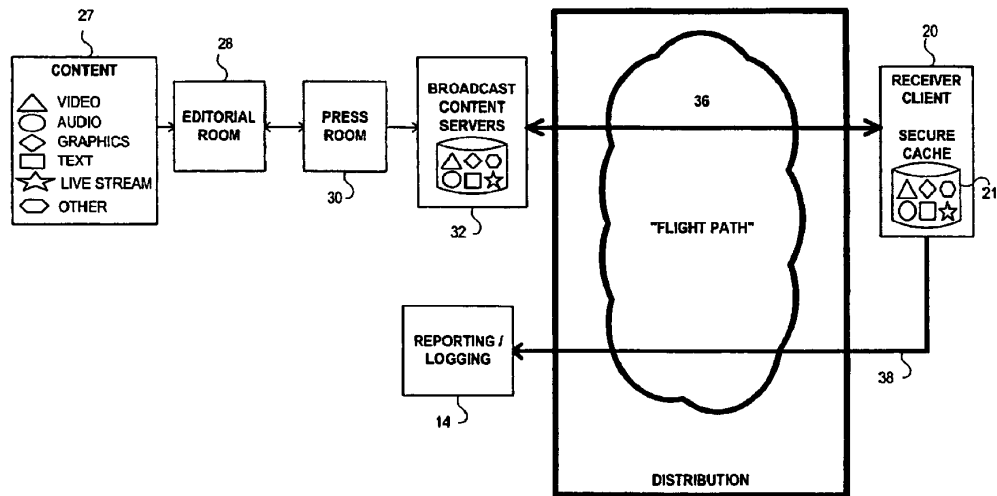

(57) Abstract: A wide-area emergency information management system includes a broadcasting entity (10) and delivers content to authorized receiver clients (20), such as PC's, laptops, wireless devices, etc. The specific content (26), which can include voice, text, video or any other information content related to a planned response to a given crisis or emergency such as enemy attack or natural disaster, is prepared in advance (28), tailored to the class of recipient receiver client and/or user (44), securely downloaded (32,36) and stored locally in a secure cache (21). In response to a small control file from a centralized emergency management authority, the receiver client system accesses the cache (21), decrypts the content (26), and delivers it to the end user.



WO 03/077063 A2

WO 03/077063 A2



Published:

— without international search report and to be republished upon receipt of that report

For two-letter codes and other abbreviations, refer to the "Guidance Notes on Codes and Abbreviations" appearing at the beginning of each regular issue of the PCT Gazette.

EMERGENCY INFORMATION MANAGEMENT SYSTEM

Related Applications

[0001] This application claims priority from U.S. Provisional Application No. 60/361,647 filed March 4, 2002.

Copyright Notice

[0002] © 2002-2003 Swan Island Networks, Inc. A portion of the disclosure of this patent document contains material which is subject to copyright protection. The copyright owner has no objection to the facsimile reproduction by anyone of the patent document or the patent disclosure, as it appears in the Patent and Trademark Office patent file or records, but otherwise reserves all copyright rights whatsoever. 37 CFR § 1.71(d).

Technical Field

[0003] The present invention pertains to emergency management and, more specifically, relates to secure, timely management of information dissemination during a crisis or disaster.

Background of the Invention

[0004] Many technologies are in place for communicating information. Information can be broadcast to a wide audience via existing television and radio stations, for example. An "emergency broadcast system" that employs existing television and radio infrastructure has been known for a long time. While this approach can be used to widely disseminate a generic message, for example a text message read by a live announcer, it is not easily customized for different recipients, and there is no "feedback" to indicate who actually received the message. Furthermore, all such broadcasts are public by design, so they cannot be used for controlled or secure communications.

[0005] Digital communications, for example via email or the Internet, have several advantages. First, they can be made relatively private, for example using known

encryption technologies, and/or login and password procedures, but all of these require some pre-arrangements at the receiving end, for example establishing a "user account". Such arrangements are not practical for widespread use when time is of the essence, as during a crisis or emergency such as a flood or military attack.

[0006] Digital communications also provide, in many cases, a convenient way to implement feedback or "closed loop" communications to ensure delivery. For example, modern email and network software ensure email delivery (or provide an error message to the sender). Email, however, requires that every recipient have an individual email user account, and that the user access that account to receive email. An urgent emergency message would be of no practical use if the intended recipient (or thousands of them) did not happen to check their email for new messages at the critical time.

[0007] For these and other reasons explained below, the need exists for improvements in the management of emergency information to ensure timely delivery of appropriate content to intended recipients, especially during an emergency when some channels of communication may be disrupted or overwhelmed by an extraordinary volume of message traffic. Also, it may also be beneficial to securely "pre-position" content in advance of a crisis or event, providing near-instantaneous availability from a local source.

Summary of the Invention

[0008] The invention is directed to management of information, in anticipation of and during times of disaster or crisis. In one aspect, it can be described as a secure, wide-area emergency information management system that utilizes a broad range of existing technologies, standards and protocols to provide a survivable method of information distribution with an auditable receive/read trail during times of disaster or crisis. The system is designed to run on a variety of computer platforms. In a presently preferred embodiment, the inventive system delivers encrypted "content" such as video, audio, graphic and text content over a wide range of public and private networks, including but not limited to the Internet, the Public Switched Telephone Network, wireless telecommunications networks, Cable, DSL, Optical Fiber and Satellite.

[0009] The inventive system delivers such content to a variety of client-receiver devices including but not limited to desktop computers, laptop computers, hand-held and palm-top computer devices, cellular telephones, pagers and anticipated

permutations and combinations of these existing device technologies. This information/data flows to these devices through a secure channel in anticipation of an emergency event and is stored on the local client in an encrypted or otherwise obfuscated cache. The cache content, or only selected portions of it, are made available to fully authorized, authenticated and classified users in times of emergency, according to the type of event and the role of the user, both while connected to a central system and on a stand-alone basis. The system also provides for real-time and near real-time streaming and live chat and local situation reporting.

Accordingly, one aspect of the invention can be described as a wide-area emergency information management system comprising the following elements:

- (a) a content authoring module for preparation of digital content for delivery in response to a predetermined class of incident to a selected recipients;
- (b) a security/authentication module for authenticating the digital content received from the content authoring module for distribution and for authenticating the selected recipients;
- (c) a policy management system coupled to the content authoring module and to the security/authentication module for managing content distribution; and
- (d) a broadcast module for securely distributing said digital content only to authenticated selected recipients authorized to receive the digital content.

[0010] In one embodiment, the system can further include a logging and reporting module for maintaining records that indicate what digital content files were accessed, when and by whom.

[0011] The system is designed for communication with a "receiver client," by which we mean a combination of hardware and/or software suitable for receiving emergency information as described herein. A receiver client is capable of communicating with the broadcast module to receive the digital content, and the receiver client preferably implements means for securely caching the digital content received from the broadcast module; means for decrypting the digital content and delivering it to an authorized user of the receiver application when authorized to do so; and means for reporting user activity back to the logging/reporting facility to confirm delivery and subsequent usage of the authenticated digital content to the selected recipients.

[0012] The policy management system in one illustrative embodiment maintains a user matrix for selecting and authorizing recipients of particular digital content based on predetermined criteria comprising one or more of a recipient's identity, grade, level, agency and location.

[0013] The policy management system can also maintain a content matrix for selecting and authorizing distribution of content based on predetermined criteria. For example, such criteria can be one or more of a DRM rule, content priority, user priority, and an alert status of the emergency information management system.

[0014] Additional aspects and advantages of this invention will be apparent from the following detailed description of preferred embodiments, which proceeds with reference to the accompanying drawings.

Brief Description of the Drawings

[0015] Figure 1 is a simplified, top-level block diagram of a secure emergency information management network in accordance with the present invention.

[0016] Figure 2 is a block diagram illustrating a secure emergency information management network in accordance with the present invention with selected server-side components shown in greater detail.

[0017] Figure 3 is an illustrative functional model of a secure emergency information management system in accordance with the present invention.

[0018] Figure 4 is a simplified flow diagram illustrating generally a method of emergency information management in accordance with one embodiment of the invention.

Detailed Description of Preferred Embodiments

General Overview

[0019] Content is prepared and submitted for distribution throughout the system by certified Publishing entities or their authorized agents or proxies. This material is prepared for user distribution in the Policy Management Module through the consideration of Rights Management, Content Priority, User Priority, Alert Status and the User Matrix (Grade, Level, Agency and Location). The content is packaged and encrypted appropriate to the type of content (Video, Audio, Graphics or Text). This material is then handled by the Mechanical Preparation Module for Quality Assurance issues, encoded and tagged with metadata suitable to the type of end receiver device (PC, Hand-held computer, Cellular Phone or Pager) and is then forwarded to the Broadcast/ Streaming Content Servers.

The Server Side

[0020] Referring now to Figure 1, a simplified architectural diagram of the emergency information management network comprises a server side 10 and an illustrative client side 20. Of course, the server side can include multiple servers (not shown), deployed at one location or, preferably, at multiple locations to improve reliability in the event of a power failure or the like at any given location. A distributed network could be used, preferably with appropriate redundancies.

[0021] At the server side, a content authoring module 18 is used to import and/ or create content to be delivered to users, as further explained later, in the event of an incident. The term "incident" is used broadly herein and in the appended claims to refer to almost any situation, crisis or emergency in which prompt yet carefully controlled distribution of information and user action would be helpful. Examples of incidents include a physical attack (via conventional explosive, chemical, biological, nuclear or other weapons, especially weapons of mass destruction; natural disasters such as flooding, hurricanes etc; wild fires, etc. The system can also be used to distribute ("pre-position") rich, e.g., multi-media data to be "delivered", i.e., displayed substantially simultaneously to intended recipients at a subsequent, scheduled time, such as an on-line meeting, new product rollout, etc.

[0022] The present invention provides for carefully controlled delivery of content to specific client devices and/ or individual users, so distinct content packages or files can be created as appropriate. As one example, a message for distribution to the general public in the case of a nuclear attack may be different from the content to be delivered to government, law enforcement or military personnel in the same scenario.

[0023] Referring again to Figure 1, the server side further includes a security/ authentication module 16 which can be used to "secure" the content to be distributed, for example using encryption or other means of obfuscation. Security can be imposed using various known means to control the client receiver devices that are authorized to receive particular content. Further, the security module can enforce authentication of persons authorized to submit or modify content, or specify the "rules" for its distribution. A distribution rule can specify, for example, classes of client machines or individual persons authorized to receive particular content.

[0024] After appropriate provisions are made for security and authentication by module 16, the corresponding content from module 18 is provided to a broadcast or

distribution module 12. Note that the broadcast module is part of the secure broadcast server facility 10 to ensure that distribution "rules" are enforced. It is possible to envision a network of broadcast modules distributed across disparate locations and controlling their interaction with the server facility via secure network protocols, such as SSL (Secure Sockets Layer), VPN (Virtual Private Networking), etc.

[0025] Content Stored on these servers is sent in the background, typically upon request from the Client 20, to be stored in a local encrypted and obfuscated cache at the client side 20. The term "background" here means that the request to download content may be sent without user interaction or input, at scheduled times, periodically, or whenever a suitable connection is available. In other words, it happens automatically even though the user may be absent or doing other things. In response to such a request, the broadcast module 12, in cooperation with the security/ authentication module 16, ensures that the requesting client is authorized, determines what content is intended for that client, and then downloads the (encrypted) content via a secure transmission module 26. All this is typically done in advance of an incident that would require delivery of the content, but may also occur in real-time as events unfold.

[0026] In this application, "broadcasting" or "distribution" of content refers to transmitting the content from a server to a receiving client device. This step is also sometimes called "pre-positioning" the content. Regardless, at that juncture, the content remains secure and is not made available to any user for viewing. Rather, it is stored locally in a secure cache for "delivery" to the end user only if and when needed as taught herein.

[0027] Prepared content can be sent securely ("distributed") over various transport paths, for example – Internet, PSTN, Wireless, Satellite and by removable media (i.e. diskettes or CDROM). Almost any device capable of receiving and storing transmitted data can be configured to serve as a receiver client for present purposes. Digital communication is preferred although analog or mixed technologies such as VOIP or in-band wireless signaling can be used.

[0028] The server side 10 also can include reporting/ analysis module 14. This module receives (preferably encrypted or otherwise secure) feedback messages and/or data from receiver clients 20 via a feedback messaging module 24. Such feedback can include reports of various activity at the client side. For example, the

feedback might indicate that the local cache is full or has been compromised. Another feedback message might indicate that a control file was successfully received; and it might further indicate what content was accessed and delivered. In a presently preferred embodiment, the feedback message would further indicate when and to whom the content was delivered. The reporting/ analysis module can use this information to determine the results of actions taken in response to an incident.

[0029] Referring now to Figure 2, this drawing further illustrates the inventive concept. The receiver client 20 includes a secure cache 21 as mentioned above. The "flight path" 36 refers to various potential distribution systems. These can range from physical media (pick up an emergency CD at the grocery store or receive one in the "mail), to cable, Internet, telecom, wireless etc. Preferably, multiple communications channels are enabled to improve reliability and availability. Importantly, the channel used for distribution of digital content (26 in Figure 1) need not be the same channel as that used to send a short emergency message or "control file" in connection with an incident. Because the control file is small, any available channel will work, even one providing very low bandwidth, such as a dialup modem over an ordinary POTS line. Email can be used.

[0030] The flight path 36 also illustrates a return or feedback path 38 for communications from the client to the server side for reporting and logging purposes. On the server side, Figure 2 illustrates a collection of content 27, for example video, audio, graphics, text, live stream, etc. used in building suitable content for emergency use. The content for ultimate distribution is assembled in the "editorial room" 28 by authorized (and qualified) personnel or their proxies. The completed content is provided to the "press room" 30 for processing further described below. Finally, the output is provided to one or more broadcast servers 32 functionally similar to the entity 10 described with reference to Figure 1 above.

[0031] Figure 3 is a system functional model, some aspects of which have already been described. In Figure 3, on the server (left) side, a policy management system 42 is coupled to the content authoring module 18 (see Figure 1) and to the security/authentication module 40 for managing content distribution. The policy management system includes three principle components or functions: First, a User Matrix 44 for selecting and authorizing recipients of particular digital content based

on predetermined criteria such as one or more of a recipient's identity, grade, level, agency and location.

[0032] Second, the policy management system 42 can also maintain a content matrix 48 for selecting and authorizing distribution of content based on predetermined criteria. For example, such criteria can be one or more of a DRM rule, content priority, user priority, and an alert status of the emergency information management system. And third, the policy management system 42 can also include an acquisition module 46 for content selection and packaging. This can include protocol implementations for inter-agency communications.

[0033] The policy management system forwards selected and properly packaged content to the "mechanical" module 50 for quality control, encoding, metadata additions if appropriate, and other preparation depending on the receiver device type, channels, etc. Note that all of this is behind a security / authorization "firewall" 52 so that all content creation and distribution management is secure. "Hacking" into an emergency information management system of this type by enemies or mere pranksters could have disastrous consequences. In this light, security is paramount, and the use of effective authentication schemes is encouraged, including voice recognition, other biometrics, FOB's or ID tokens, "dongle" or other hardware ID techniques, etc. The remaining modules 54, 56, 58 in Figure 3 have adequate explanatory labels in the drawing.

Summary of Emergency Operation

[0034] In the event of an emergency, a small control file is sent via any available transport to the various client devices, as noted above, triggering the appropriate alert and requiring a user response. The locally cached data that is necessary to the authorized user in this type of event is either accessed directly from the secure cache or, in the event it is not stored, is delivered and the local logging and reporting function returns a small log file to the reporting and logging module reporting that the alert has been received, which content has been viewed, when and by whom.

[0035] The present system for Emergency Information Management is unique in its ability to make secure, Rich Media-based information services available in times of limited or severely disrupted communications ensuring that the right information reaches the right personnel at the right time. Put another way, the present invention includes a secure audio/video/text communications channel, or links to such

channels, over the Internet, designed to provide targeted information to key responders and managers, on a need-to-know basis, during an emergency.

[0036] The present invention is useful in connection with the following functions:

- Immediately link both governmental and authorized non-governmental responders, in near real-time, with command-and-control decision centers;
- Transmit information securely, limiting the information to those with a certified need to know;
- Override ordinary computer operations in order to deliver a rich-media emergency message to thousands of certified officials, at once;
- Allow for multiple points of authorized-content entry—while also reaching many users who would be prohibited from inputting information;
- Connect to a variety a wireless devices, providing a means of communicating securely, in a coordinated fashion, with responders at the scene of an incident;
- Deliver video, audio, rich graphics, text and Web applications (forms, reporting, etc.) via a single system.

[0037] The invention leverages a combination of secure content delivery technologies that are in wide use today on the Internet (and likely will employ others not yet known). By combining elements of digital rights management (DRM), rich media streaming and downloading, secure caching, digital certificate authentication (and certificate authority systems), and various neural net rules engines—all linked to common local applications such as Windows Media Player and Adobe Reader—the present invention enables a new secure communications channel, with surprisingly low operational or technical overhead.

[0038] In an illustrative implementation, the present invention provides a secure PC-based webcasting type of network that delivers to each of its certified users a special client “Receiver.” This receiver 20 is small application built with such components as common media players and related DRM tools, and utilizes advanced “secure access” technology (e.g., digital certificate-based ID authentication).

[0039] The receiver software client can easily be downloaded, in advance, by all certified users. The receiver then checks in regularly and automatically with a set of “home” servers, whenever the user is online. Content files—audio, video or

text/graphics, as well as “rules” and system instructions that are opaque to the user—are then “pulled” down to the local PC, according to dynamic protocols set at a command center. The system can (and should, to breed user familiarity) be used to provide security updates, instruction and overall coordination in non-crisis situations. But its main purpose is to provide secure communications in a coordinated manner during a crisis.

[0040] One unique feature of the receiver client is its extensive use of secure caching technology. By building a secure cache into every receiver, the information management system is able to deliver and securely store all files that are passed to the local PC. A low-level user does not have access to the cache contents directly: He or she can view them only through the use of the client application. Higher level users can be given rights to capture the files, if necessary. Furthermore, many rich media files can be stored locally on the user’s PC, ready to be played instantly in the case of an emergency.

[0041] Thus, standard emergency procedure instructions—say, for the evacuation of a city—can be programmed centrally, and played locally upon command from the center of operations. The playback (*delivery*) of these files is controlled by this command center, via settings that are communicated to a local rules engine that resides in each user’s receiver. The settings are transmitted in a relatively small “control file”. The control file need not come from the same server as originated the content (although the two functions should be coordinated).

[0042] In times of emergency, this local engine drives the system’s Override function, in effect “turning on” the emergency receiver, and automatically suppressing non-emergency uses of the receiving machine. This Override might be, for example, a full-screen video display, instantly taking over the user’s screen.

[0043] Figure 4 provides a flow diagram of a method of information management in accordance with the present invention. Figure 4 illustrates the steps of creating content 70; distributing the content to receiver clients 72; and storing the content in a secure local cache. It may be updated periodically as described. Subsequently, if and when an incident occurs (or an incident is imminent, or recently occurred), a message or control file is sent to the receiver client 76, which immediately interrupts other activity on the client device if necessary. The client software reads the control file 78, and based on indicia therein, which preferably are encoded, the client accesses the content previously stored in the secure cache, step 80. This accessing

step includes decryption other steps necessary to delivery of the content in a form meaningful to the human user. Authentication of the user is part of the delivery process. Finally, as mentioned above, the receiver client sends a feedback message to the server logging/ analysis module confirming the transaction. Another part of the feedback loop includes the user's ability to access response forms and incident reports within the receiver client and to send that information as part of the feedback loop. These reports can include detailed information about specific incidents, as well as digital attachments such as images or audio files.

[0044] While a PC-only system to start, advanced versions of the described system will also link to wireless devices via highly secure CDMA communications. Also, over time, the system could evolve from its initial media delivery interface and functionality (mirroring TV, radio and newspapers) into a digital dashboard that would include an increasing number of real-time monitoring, statistical delivery and command-and-control functions.

[0045] Also, because of preferred "phone home," or pull, architecture, rich reporting capabilities not only provide additional security, but also an immediate feedback mechanism to determine just who is online getting access to the emergency information, and who is not. It also leaves a tamper-proof record of precisely what information was sent to whom, by whom, and when, for incident analysis after a crisis has subsided as well as the full auditing functions of how that content was used by the users

[0046] The present system's biggest short-term advantage for homeland security is the fact that it is extremely light on the user end. No special training is required; in fact, it is literally plug-and-play. All security—except for the user authentication during log-on—happens in background, with no user requirements.

[0047] The central hubs of the contemplated system do require a considerable investment in network operations. Also, except in the case of text files, emergency message production and "content prep" require considerable investment in systems and training. When routine video production (or video conferencing) capabilities are in place, the only additional system requirements at the command/control points are a streamlined, highly-automated, content prep process (encoding, encrypting) and a professional online network operations competency.

[0048] Yet these investments of time, money, training and continuing system overhead are minuscule compared to a stand-alone system using radio, television

broadcast in a proprietary communications system. While the present system is not designed to replace the most secure and private communications, it can instantly and effectively increase the communication and coordination among those who have a need for vital information during an emergency.

[0049] It will be obvious to those having skill in the art that many changes may be made to the details of the above-described embodiments without departing from the underlying principles of the invention. The scope of the present invention should, therefore, be determined only by the following claims.

Claims

1. A wide-area emergency information management system comprising:
 - a content authoring module for preparation of digital content for delivery in response to a predetermined class of incident to selected recipients;
 - a security/authentication module for authenticating the digital content received from the content authoring module for distribution and for authenticating the selected recipients;
 - a policy management system coupled to the content authoring module and to the security/authentication module for managing content distribution;
 - a broadcast module for securely distributing said digital content only to authenticated selected recipients authorized to receive the digital content;
 - a logging and reporting module for maintaining records related to delivery of the digital content; and
 - a plurality of receiver applications capable of communicating with the broadcast module to receive the digital content, each receiver application including –
 - means for securely caching the digital content received from the broadcast module;
 - means for decrypting the digital content and delivering it to an authorized user of the receiver application in response to a control file directive; and
 - means for reporting user activity back to the logging/reporting facility to confirm delivery of the authenticated digital content to the selected recipients.
2. A wide-area emergency information management system according to claim 1 wherein the policy management system maintains a user matrix for selecting and authorizing recipients of particular digital content based on predetermined criteria comprising one or more of a recipient's identity, grade, level, agency and location.
3. A wide-area emergency information management system according to claim 1 wherein the policy management system maintains a content matrix for selecting and authorizing distribution of content based on predetermined criteria comprising one or more of a DRM rule, content priority, user priority, and an alert status of the emergency information management system.

4. A wide-area emergency information management system according to claim 1 wherein the policy management system includes a content acquisition system coupled to the content authoring module for selection and content packaging.

5. A wide-area emergency information management system according to claim 1 wherein the receiver application decrypts and delivers the cached digital content to the authorized user only in response to receipt of an incident control file.

6. A wide-area emergency information management system according to claim 5 wherein the incident control file identifies specific digital content files to be decrypted and delivered to the user.

7. A wide-area emergency information management system according to claim 6 wherein the receiver application reports to the logging/reporting facility indicia of what digital content file has been delivered to which authorized user and, optionally, the user's observations of his immediate environment.

8. A wide-area emergency information management system according to claim 7 wherein the report to the logging/reporting facility includes a date/time stamp indicating when the indicated digital content file was delivered to the user.

9. A wide-area emergency information management system according to claim 7 wherein the report to the logging/reporting facility includes a location stamp indicating where the receiver application was located when the indicated digital content file was delivered to the user.

10. A wide-area emergency information management system according to claim 7 wherein the receiver application further includes means for updating the cache of digital content as new or updated content becomes available to it from the broadcast module.

11. A method of emergency information management to ensure distribution of information to entities having a need to know in the event of an incident, the method comprising the steps of:

- creating digital content comprising any combination of video, audio, graphics, text or other digital data for controlled delivery to an authorized user;
- distributing the digital content to a digital device;
- storing the digital content in a secure cache in the digital device;
- in response to an incident, transmitting a control file to the digital device; and

in the digital device, responsive to indicia contained in the control file, accessing the digital content in the secure cache and delivering the content to a user of the digital device.

12. A method of emergency information management according to claim 11 and further comprising authenticating the user as a prerequisite to said delivering the content to the user.

13. A method of emergency information management according to claim 11 wherein the control file identifies what specific aspect of the digital content should be accessed and delivered.

14. A method of emergency information management according to claim 11 wherein the control file identifies a specific individual user who is thereby authorized to receive the digital content.

15. A method of emergency information management according to claim 11 and further comprising transmitting from the digital device to a central emergency management authority an indication that the control file was received.

16. A method of emergency information management according to claim 15 wherein the indication that the control file was received includes a date and time stamp.

17. A method of emergency information management according to claim 11 and further comprising transmitting from the digital device to a central emergency management authority an indication of what cached digital content was accessed.

18. A method of emergency information management according to claim 17 wherein the indication that the cached digital content was accessed includes a date and time stamp.

19. A method of emergency information management according to claim 17 wherein the indication that the cached digital content was accessed includes identification of the user to whom the content was delivered.

20. A method of emergency information management according to claim 17 wherein the control file includes a key for decrypting the digital content identified for access and delivery.

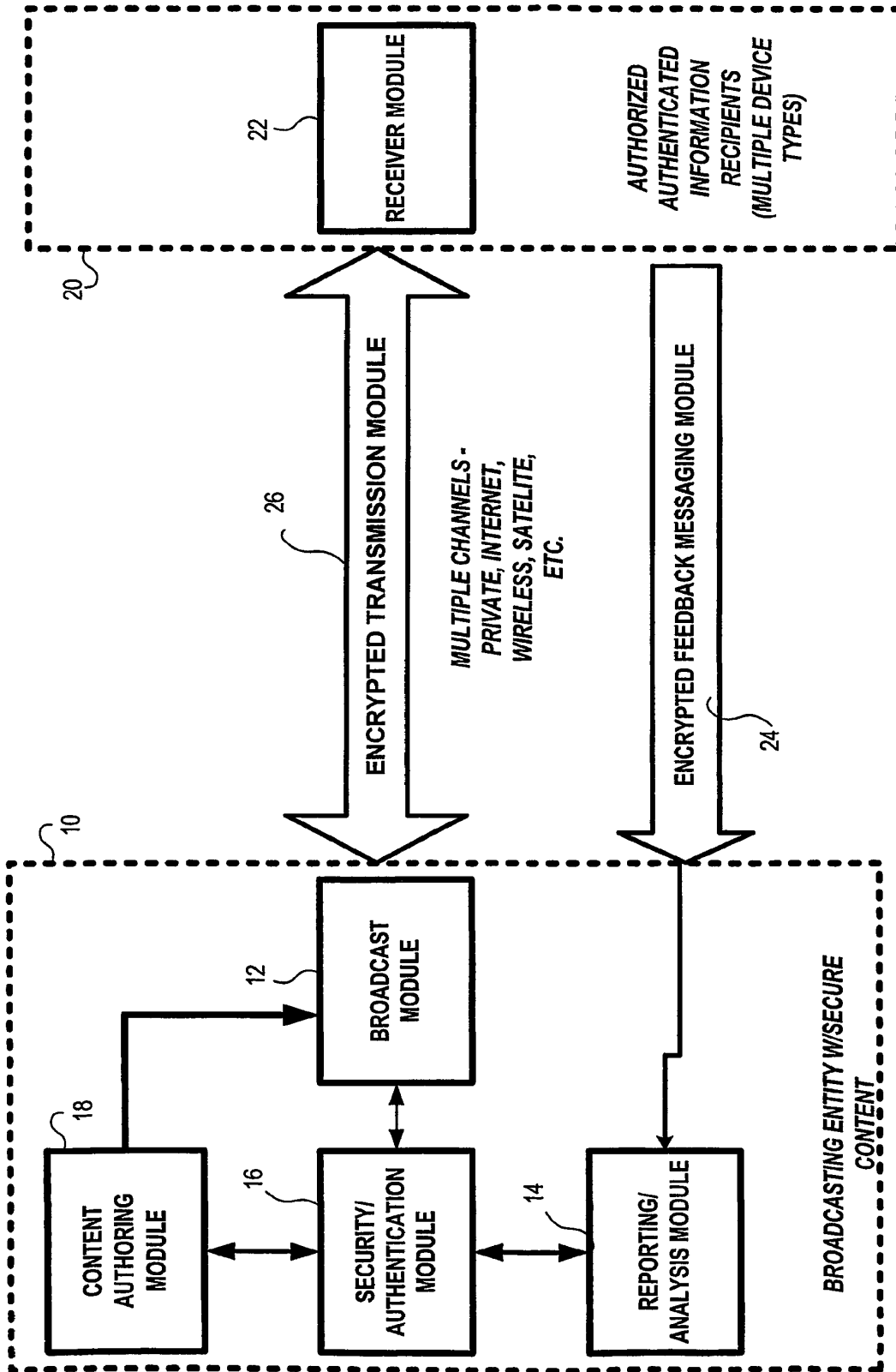

FIG. 1

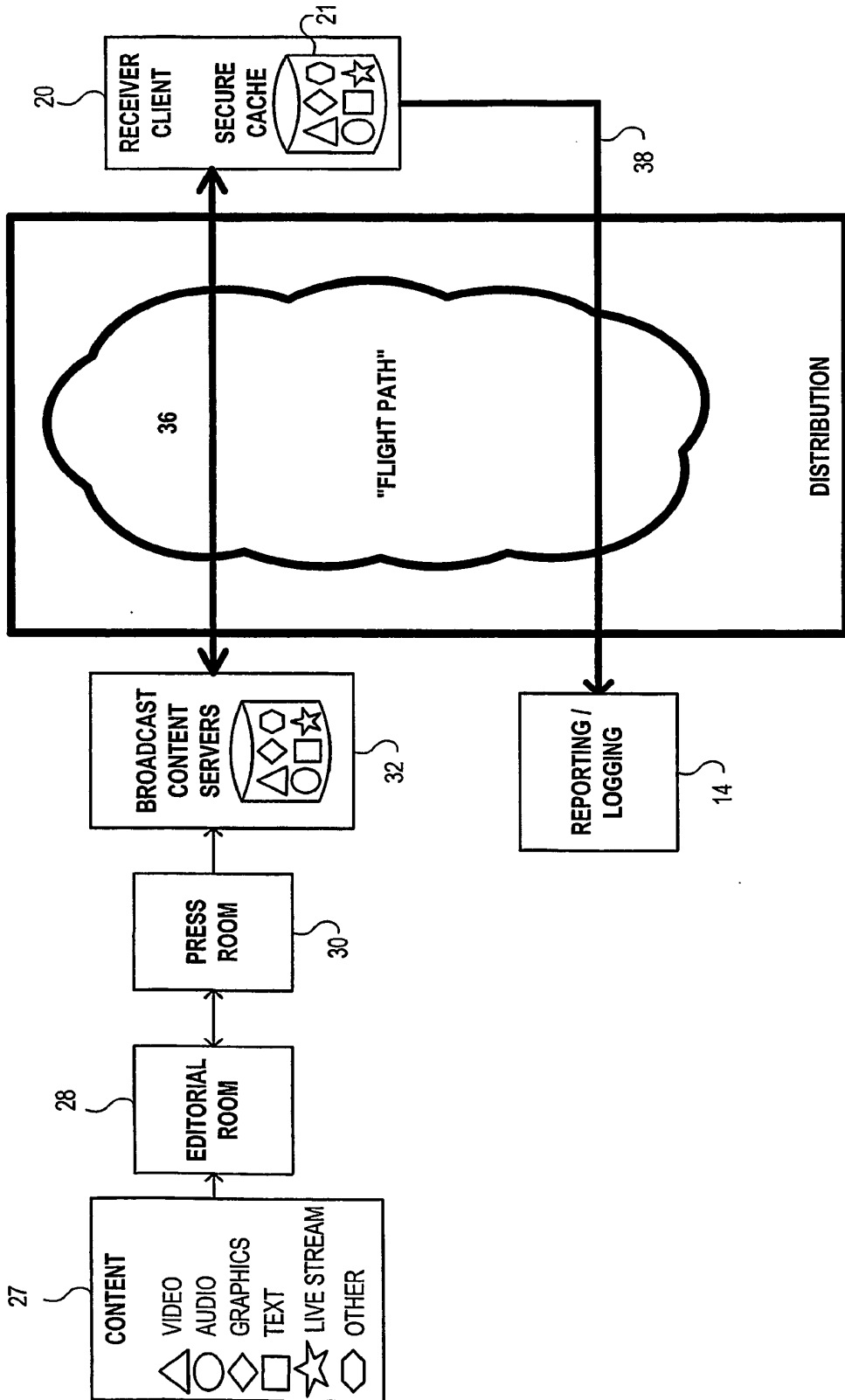

FIG. 2

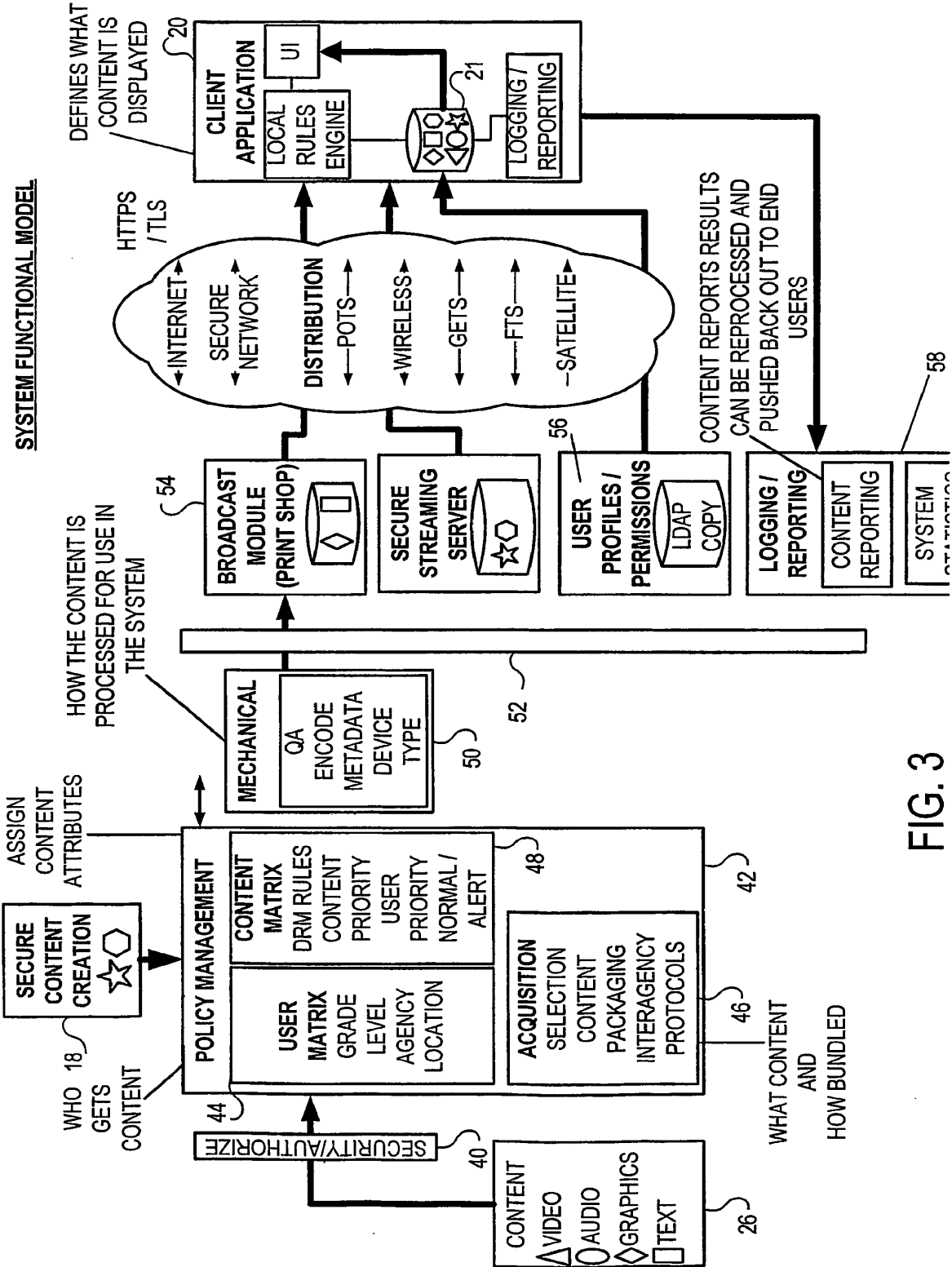

FIG. 3

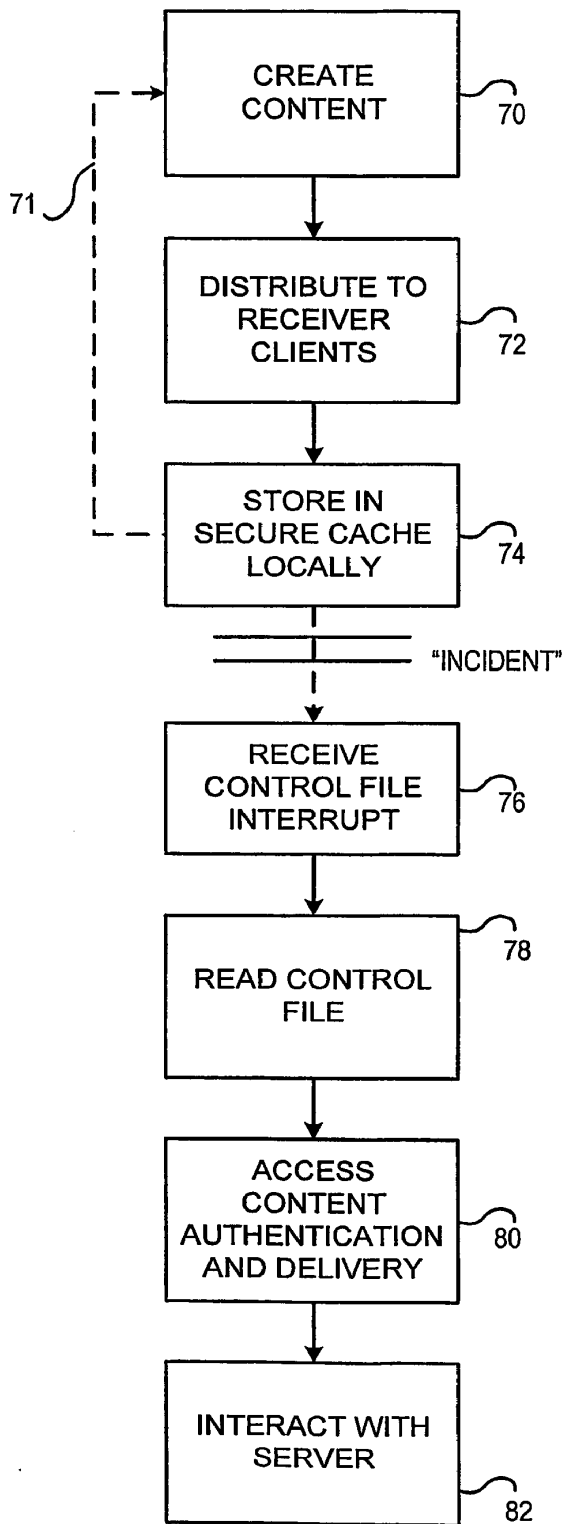

FIG. 4

(12) INTERNATIONAL APPLICATION PUBLISHED UNDER THE PATENT COOPERATION TREATY (PCT)

(19) World Intellectual Property Organization
International Bureau



(43) International Publication Date
18 September 2003 (18.09.2003)

PCT

(10) International Publication Number
WO 2003/077063 A3

(51) International Patent Classification⁷: G06F 11/30, 12/14, H04L 9/00, 9/32

(21) International Application Number: PCT/US2003/006526

(22) International Filing Date: 4 March 2003 (04.03.2003)

(25) Filing Language: English

(26) Publication Language: English

(30) Priority Data: 60/361,647 4 March 2002 (04.03.2002) US

(71) Applicant (for all designated States except US): SWAN ISLAND NETWORKS, INC. [US/US]; 55 SW Yamhill, Suite 400, Portland, OR 97204 (US).

(72) Inventors; and

(75) Inventors/Applicants (for US only): HEELAN, Jake [US/US]; 3566 SW Council Crest Drive, Portland, OR 97239 (US). JENNINGS, Charles [US/US]; 11553 NW Damascus, Portland, OR 97229 (US). O'DELL, Pete [US/US]; 7925 NW Blue Pointe Lane, Portland, OR 97229

(US). MCMAHON, Ryan [US/US]; 3306 NE Pacific Street, Portland, OR 97232 (US). ROHOLT, Grant [US/US]; 2735 NE 18th Avenue, Portland, OR 97212 (US).

(74) Agent: STOLOWITZ, Micah, D.; Stoel Rives LLP, 900 SW Fifth Avenue, Suite 2600, Portland, OR 97204-1268 (US).

(81) Designated States (national): AE, AG, AL, AM, AT, AU, AZ, BA, BB, BG, BR, BY, BZ, CA, CH, CN, CO, CR, CU, CZ, DE, DK, DM, DZ, EC, EE, ES, FI, GB, GD, GE, GH, GM, HR, HU, ID, IL, IN, IS, JP, KE, KG, KP, KR, KZ, LC, LK, LR, LS, LT, LU, LV, MA, MD, MG, MK, MN, MW, MX, MZ, NO, NZ, OM, PH, PL, PT, RO, RU, SC, SD, SE, SG, SK, SL, TJ, TM, TN, TR, TT, TZ, UA, UG, US, UZ, VC, VN, YU, ZA, ZM, ZW.

(84) Designated States (regional): ARIPO patent (GH, GM, KE, LS, MW, MZ, SD, SL, SZ, TZ, UG, ZM, ZW), Eurasian patent (AM, AZ, BY, KG, KZ, MD, RU, TJ, TM), European patent (AT, BE, BG, CH, CY, CZ, DE, DK, EE, ES, FI, FR, GB, GR, HU, IE, IT, LU, MC, NL, PT, RO, SE, SI, SK, TR), OAPI patent (BF, BJ, CF, CG, CI, CM, GA, GN, GQ, GW, ML, MR, NE, SN, TD, TG).

[Continued on next page]

(54) Title: EMERGENCY INFORMATION MANAGEMENT SYSTEM

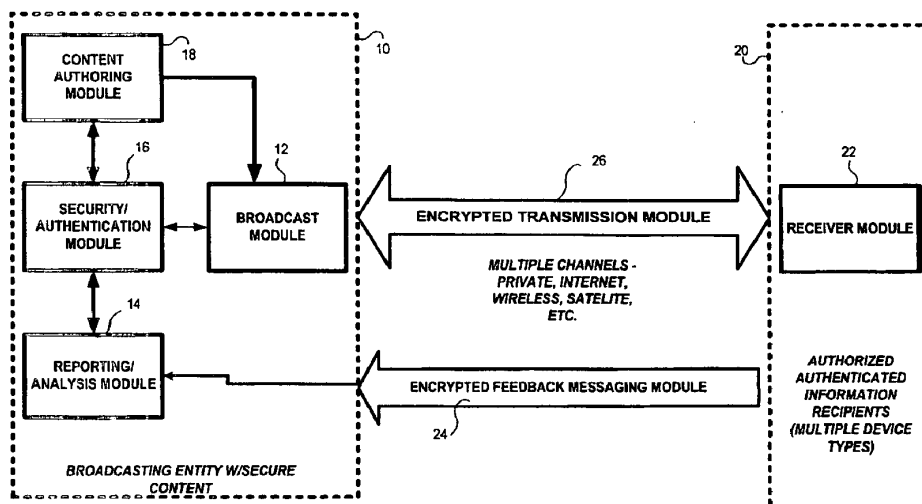

(57) Abstract: A wide-area emergency information management system includes a broadcasting entity (10), and delivers content to authorized receiver clients (20), such as PC's, laptops, wireless devices, etc. The specific content (26), which can include voice, text, video or any other information content related to a given crises or emergency such as enemy attack or natural disaster, is prepared in advance. Tailored to the class of recipient receiver client and/or user (20), securely downloaded and stored locally in a secure cache. In response to a small control file from a centralized emergency management authority, the receiver client system(20), accesses the cache, decrypts the content, and delivers it to the end user.

WO 2003/077063 A3



Published:

— with international search report

(88) Date of publication of the international search report:
5 February 2004

For two-letter codes and other abbreviations, refer to the "Guidance Notes on Codes and Abbreviations" appearing at the beginning of each regular issue of the PCT Gazette.

INTERNATIONAL SEARCH REPORT

International application No.

PCT/US03/06526

A. CLASSIFICATION OF SUBJECT MATTER

IPC(7) : G06F 11/30, 12/14; H04L 9/00, 9/32
 US CL : 713/200, 200

According to International Patent Classification (IPC) or to both national classification and IPC

B. FIELDS SEARCHED

Minimum documentation searched (classification system followed by classification symbols)
 U.S. : 713/200, 200; 380/277, 278, 279

Documentation searched other than minimum documentation to the extent that such documents are included in the fields searched

Electronic data base consulted during the international search (name of data base and, where practicable, search terms used)
 EAST Database

C. DOCUMENTS CONSIDERED TO BE RELEVANT

Category *	Citation of document, with indication, where appropriate, of the relevant passages	Relevant to claim No.
X	US 6,084,510 A (Lemelson et al) 04 July 2000 (04.07.2000), column 3, lines 24-28; column 4, lines 4-27; column 5, lines 54-60; column 13, lines 19-20; column 14, lines 19-26; column 16, lines 55-67.	1-7, 11-14
Y		8-10, 15-20
Y	US 6,247,059 B1 (Johnson et al) 12 June 2001 (12.06.2001), column 2, lines 30-34; column 5, lines 64-67.	8-10, 15-19
Y	US 6,169,805 B1 (Dunn et al) 02 January 2001 (02.01.2001), column 2, lines 16-21.	20
A	US 5,636,245 A (Ernst et al) 03 June 1997 (03.06.1997), column 2, lines 1-6; column 2, lines 15-35, 50-58.	1-20

Further documents are listed in the continuation of Box C.

See patent family annex.

* Special categories of cited documents:

"A"	document defining the general state of the art which is not considered to be of particular relevance	"T"	later document published after the international filing date or priority date and not in conflict with the application but cited to understand the principle or theory underlying the invention
"E"	earlier application or patent published on or after the international filing date	"X"	document of particular relevance; the claimed invention cannot be considered novel or cannot be considered to involve an inventive step when the document is taken alone
"L"	document which may throw doubts on priority claim(s) or which is cited to establish the publication date of another citation or other special reason (as specified)	"Y"	document of particular relevance; the claimed invention cannot be considered to involve an inventive step when the document is combined with one or more other such documents, such combination being obvious to a person skilled in the art
"O"	document referring to an oral disclosure, use, exhibition or other means	"&"	document member of the same patent family
"P"	document published prior to the international filing date but later than the priority date claimed		

Date of the actual completion of the international search

20 August 2003 (20.08.2003)

Date of mailing of the international search report

11 SEP 2003

Name and mailing address of the ISA/US

Mail Stop PCT, Attn: ISA/US
 Commissioner for Patents
 P.O. Box 1450
 Alexandria, Virginia 22313-1450
 Facsimile No. (703)305-3230

Authorized officer

Gilberto Barron *for James R. Matthews*
 Telephone No. (703) 305-3900

Form PCT/ISA/210 (second sheet) (July 1998)

EWIT 9834-9839
Master copy

(19) World Intellectual Property
Organization
International Bureau



(43) International Publication Date
1 September 2005 (01.09.2005)

PCT

(10) International Publication Number
WO 2005/079421 A2

(51) International Patent Classification: Not classified

(21) International Application Number:
PCT/US2005/004897

(22) International Filing Date: 14 February 2005 (14.02.2005)

(25) Filing Language: English

(26) Publication Language: English

(30) Priority Data:
60/544,739 13 February 2004 (13.02.2004) US

(71) Applicant and

(72) Inventor: WEISER, Douglas, D. [US/US]; 623 Lakeview
Road, Lake St. Louis, MO 63376 (US).

(74) Agent: WHEELLOCK, Bryan, K.; Harness, Dickey &
Pierce, P.L.C., Suite 400, 7700 Bonhomme Avenue, St.
Louis, MO 63105 (US).

(81) Designated States (unless otherwise indicated, for every
kind of national protection available): AE, AG, AL, AM,

AT, AU, AZ, BA, BB, BG, BR, BW, BY, BZ, CA, CH, CN,
CO, CR, CU, CZ, DE, DK, DM, DZ, EC, EE, EG, ES, FI,
GB, GD, GE, GH, GM, HR, HU, ID, IL, IN, IS, JP, KE,
KG, KP, KR, KZ, LC, LK, LR, LS, LT, LU, LV, MA, MD,
MG, MK, MN, MW, MX, MZ, NA, NI, NO, NZ, OM, PG,
PH, PL, PT, RO, RU, SC, SD, SE, SG, SK, SL, SY, TJ, TM,
TN, TR, TT, TZ, UA, UG, US, UZ, VC, VN, YU, ZA, ZM,
ZW.

(84) Designated States (unless otherwise indicated, for every
kind of regional protection available): ARIPO (BW, GH,
GM, KE, LS, MW, MZ, NA, SD, SL, SZ, TZ, UG, ZM,
ZW), Eurasian (AM, AZ, BY, KG, KZ, MD, RU, TJ, TM),
European (AT, BE, BG, CH, CY, CZ, DE, DK, EE, ES, FI,
FR, GB, GR, HU, IE, IS, IT, LT, LU, MC, NL, PL, PT, RO,
SE, SI, SK, TR), OAPI (BF, BJ, CF, CG, CI, CM, GA, GN,
GQ, GW, ML, MR, NE, SN, TD, TG).

Published:

— without international search report and to be published
upon receipt of that report

For two-letter codes and other abbreviations, refer to the "Guid-
ance Notes on Codes and Abbreviations" appearing at the begin-
ning of each regular issue of the PCT Gazette.

(54) Title: PUBLIC SERVICE MESSAGE BROADCASTING SYSTEM AND METHOD

Cell@lert system Components

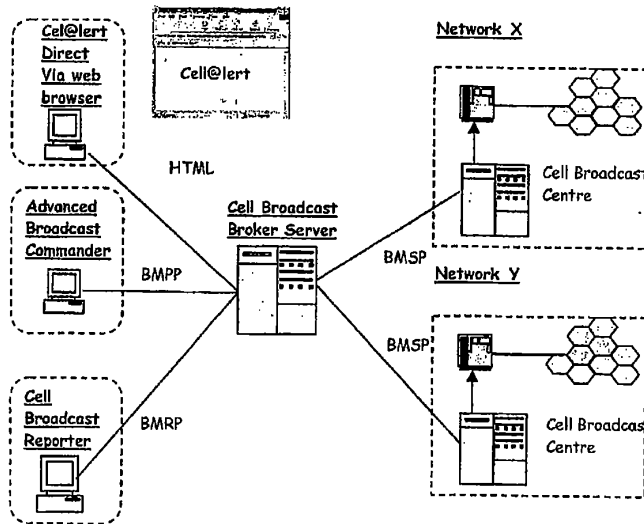

(57) Abstract: The public service message location broadcast system and method provides for broadcasting a message to communication receiving devices located within a defined geographic broadcast target area. The broadcast target area is defined by a broadcast agent using a broadcast agent webpage and a broadcast service bureau transmits the broadcast message to one or more local carriers who provide telecommunication service to the broadcast target area. The local carrier transmits the broadcast message to targeted users within the broadcast target area.

WO 2005/079421 A2

PUBLIC SERVICE MESSAGE BROADCASTING SYSTEM AND METHOD

FIELD OF THE INVENTION

[0001] The present invention relates to emergency message broadcast systems and in particular location-specific public service message broadcasting.

BACKGROUND OF THE INVENTION

[0002] With the events of 9/11, there has been increased concern with the ability of present systems for providing public service broadcasting of messages and warnings to the public. Existing public service warning systems are antiquated and provide only limited access to the public who may be in need of knowing of potential emergencies or danger. Additionally, existing systems do not provide for location-based notification or broadcasting.

[0003] As such, there is a need for an improved method and system for providing timely information to the public related to potential hazards affecting them. One suggested solution is the utilization of the subscription-based Short Message Service (SMS) messaging capability for mass messaging using mobile telephones and compatible devices. However, SMS systems and technology have significant technical limitations and experience with such systems has been disappointing due to significant delays in the delivery of SMS messages and negative impacts to the networks due to congestion.

[0004] Short Message Service (SMS) is only offered or available on a limited basis. This is due to the limited technical and network support for the service and is also due to the service being offered by Mobile Service Providers and wireless network providers on a subscription basis. As such, use of the SMS service capability for emergency broadcasting is very limited.

[0005] Additionally, the use of SMS technology for broadcasting requires enormous network infrastructure utilization. A telecommunication system can suffer from congestion, not only in its voice traffic channels, but also in its narrow-band data channels as are used for the SMS service. To send an SMS message, network components are utilized to provide an SMS message call set up for each individual SMS message recipient. In order to send a single SMS message, all SMS message call processing procedures have to be repeated for each and every message, one by

one, for all intended recipients. A single SMS message requires signaling and processor capacity and utilization similar to that required to establish a voice call. As such, the impact on network resources for broadcasting SMS messages is the same as having thousands of phone users attempt to initiate a voice call at the same time. Telecommunication networks are not designed or deployed to handle such high levels of simultaneous call attempts.

[0006] When an SMS message is transmitted, the SMS message is signaled to an SMS center of the telecommunication service provider. The SMS center acknowledges each and every requested SMS message individually and attempts to deliver the SMS message through an interrogation of the Home Location Register (HLR) of the telecommunication service. An HLR is a data base which registers or keeps track of the presence of a mobile unit user within the HLR's defined serving network. The HLR queries the database and determines whether the intended SMS message recipient is currently attached to the network and if so, to which network switch the user is attached. The HLR is queried using the telecommunication signaling network.

[0007] If an intended user is located or attached to a switch in the telecommunication service provider's network, the particular network switch is signaled over the telecommunications signaling network to set up the SMS message call. That serving network switch of the mobile carrier initiates a query or message attempt to every cell in the location area where the intended user's mobile unit was last known to be operating. If the intended recipient is located in the particular cell area, the mobile unit is paged. As such, potentially thousand of cells are queried in order to determine the presence of an intended mobile unit. Each queried cell requires paging and calling capacity resources for each mobile unit which is attempted to be paged. In some cases, if the mobile unit does not reply, the whole Mobile Service Carrier (MSC) area is paged which in many instances requires the paging of several thousands of cells.

[0008] When the mobile unit replies by sending an access burst to the cell transceiver currently serving the mobile unit, the cell site allocates a stand-alone dedicated control channel (SDCCH) to perform SMS call set up with the mobile unit. Next, a cipher key is sent by the Home Location Register (HLR)/Authentication Center (AUC) to the mobile unit, assuming that the mobile unit had previously activated the ciphering of the channel. Once the cipher key is successfully received

and acknowledged, the SMS message is sent over the control channel to the mobile unit. The SMS message transmission utilizes about 5 seconds of control channel time per SMS message.

[0009] If, however, the intended recipient is not located in the home serving area of the HLR, then signaling message is sent to the serving mobile network's Visitor Location Register (VLR). The VLR registers and tracks mobile unit users who are outside of their home location. In that case, the VLR is queried via the signaling network to verify that the user is currently attached to the remote switch.

[0010] Each SMS message is a narrow-cast message in that each message is generated and transmitted via the SMS Center to a particular telecommunication user or unit. The SMS message is delivered, as discussed above, to the intended recipient by capable networks wherever the intended recipient is located, independent of geographic area or location.

[0011] As such, SMS messaging for emergency-based messaging requires that SMS messages be created and sent to each mobile unit even though the particular user phone is not located in the particular geographic area in which the emergency is located. SMS service is not capable of position-specific messaging.

[0012] Additionally, SMS messaging requires considerable call processing load on the telecommunication system and infrastructure considering that the above process is multiplied by the demand of thousands or tens of thousands of SMS call set up requests at the same time. The potential initiation of broadcast SMS volumes will not only affect network resources for SMS messaging, but also negatively affect ability of the telecommunication networks to set up and support voice traffic during any period of message broadcasting as these resources are shared by both services.

[0013] As a further example of the limitation of existing solutions to message broadcasting, the well deployed Global Standard for Mobile Communications (GSM) system typically deploys in a single GSM cell several transceivers. A typical GSM cell configuration includes between 6 and 12 transceivers. Each such transceiver includes 8-timeslots. Each timeslot supports a single phone call.

[0014] In such an arrangement, one of the transceivers is selected to be the SMS carrier. The SMS carrier transceiver is arranged differently, having one timeslot dedicated to broadcast SMS messages and paging and another one which is utilized to from 8 control channels which are referred to as Stand-Alone Dedicated Control

Channels (SDCCH). The SDCCH carry out control and call set-up functions and carry the SMS traffic which is not normally handled by the traffic channels on the other timeslots.

[0015] However, in this prior art system, SMS and Wireless Access Protocol (WAP) messaging utilize capacity on these channels making them unavailable for other purposes such as voice call set up. Additionally, each of the SDCCH channels can only handle a limited number of SMS and/or paging calls. As such, during heavy messaging, the related high volumes of messaging traffic may have a negative affect on other services including the set up of voice calls.

[0016] To compensate for these and other SMS messaging limitations, dynamic channel allocation was developed. Dynamic channel allocation utilizes an additional traffic channel which is converted into another 8 control channels for the duration of the peak SMS or paging loads. However, this results in the loss of the traffic channel for voice communications.

[0017] Further strategies have included the immediate assignment to a traffic channel. In this system, when a voice call is attempted, the voice call is sent to a traffic channel directly where signaling will be performed on the traffic channel. This, however, occupies the traffic channel for a longer time than would otherwise be the case. There is a limit on the number of traffic channels that can utilize this feature. In most cases, only one traffic channel is converted thereby only limited the solution to 8 new SDCCH channels. The impact of call failure due to control channel depends on the traffic capacity of the cell. In high density cells, when a large quantity of SMS messaging traffic is offered, congestion occurs due to the each cell having over one hundred traffic channels within the cell.

[0018] In operation, the telecommunication service provider addresses this limitation by throttling the SMS messaging rate so that it is manageable and does not create congestion problems. However, such message load management negatively impacts the opportunity for using SMS messaging for broadcasting emergency messages to users of those networks. Throttling often significantly delays the delivery of the SMS message, even though it's timing delivery in an emergency is critical. Furthermore, if a message fails to be delivered, the SMS center repeatedly attempts to deliver the message, thereby causing further congestion and message backlog.

[0019] Additionally, as discussed SMS messaging is not location based and does not send messages to intended recipients located within a defined geographic location. Since many telecommunication users will be messages independent of their location, many of the generated SMS messages are sent to users who are not in the intended area.

[0020] In the alternative, some next-generation phone systems include a basic cell-based broadcasting capability, e.g., GMS, CDMA and UMTS. In such systems, the cell broadcasting capability allocates a portion of each timeslot bandwidth capacity in each cell as a reserved broadcast timeslot. While the cell broadcast capability is included in many new equipment being deployed, cell broadcasting systems and services have not been developed which effectively utilize the technology.

SUMMARY OF THE INVENTION

[0021] The embodiments of the present invention provide one or more improvements over the prior art.

[0022] In one aspect, the invention comprises a public service message broadcast system providing a broadcast message to a broadcast target area. The system includes a broadcast agent webpage that receives broadcast agent input defining the broadcast target area and the broadcast message. The system also includes a carrier broadcast server that transmits the broadcast message to the broadcast target area. The system further includes a broadcast service bureau that hosts the broadcast agent webpage and is coupled to the carrier broadcast server. The broadcast service bureau receives the broadcast agent input and transmits the broadcast message to the carrier broadcast server.

[0023] In another aspect, the invention comprises public service message broadcast service bureau system providing a broadcast message to a broadcast target area. The system includes a first communication interface coupled to a first network and a second communication interface coupled to a second network. The system also includes a webpage that receives broadcast agent input defining the broadcast target area and the broadcast message. The system further includes a computer hosting the webpage over the first communication interface. The computer also receives the broadcast agent input and transmits the broadcast message to a local broadcast system over the second communication interface.

[0024] Yet in another aspect, the invention comprises a website interface system for a public service message broadcasting system. The website interface includes a broadcast agent device with a display for displaying a broadcast agent webpage. The website interface also includes a webpage host that communicates with the broadcast agent device and establishes a communications interface between the broadcast agent device and the webpage host. The broadcast agent device receives broadcast agent input that defines the broadcast target area and the broadcast message. The broadcast agent device also transmits the broadcast target area and the broadcast message to the webpage host over the communication interface.

[0025] In another aspect, the invention comprises a method of public service broadcast messaging to a broadcast target area. The method includes hosting a broadcast agent webpage and receiving a broadcast target area and a broadcast message from the broadcast agent webpage. The method also includes transmitting the broadcast message to the broadcast target area.

[0026] Further aspects of the present invention will become apparent from the detailed description provided hereinafter. It should be understood that the detailed description and specific examples, while indicating the preferred embodiment of the invention, are intended for purposes of illustration only and are not intended to limit the scope of the invention.

BRIEF DESCRIPTION OF THE DRAWINGS

[0027] The present invention will become more fully understood from the detailed description and the accompanying drawings.

[0028] FIG. 1 is a functional block diagram of a public service message location broadcast system according to one embodiment.

[0029] FIG. 2 is a second functional block diagram of a public service message location broadcast system according to one embodiment.

[0030] FIG. 3 is a flow chart for an admission control process within the public service message location broadcast system service bureau according to one embodiment.

[0031] FIG. 4 is a screen shot of the Broadcast Agent Portal Webpage.

[0032] FIG. 5 is a screen shot of the Broadcast Agent Portal Webpage illustrating a Broadcast Agents initial designation of a target broadcast area.

[0033] FIG. 6 is a screen shot of the Broadcast Agent Portal Webpage illustrating use of a shape tool to refine the designation of a target broadcast area.

[0034] FIG. 7 is a screen shot of the Broadcast Agent Portal Webpage illustrating a library of foot print or predefined target broadcast areas.

[0035] FIG. 8 is a screen shot of the Broadcast Agent Portal Webpage illustrating a dialogue box enabling the Broadcast Agent to create a message and parameters of the Broadcast Request.

[0036] FIG. 9 is a screen shot of the Broadcast Agent Portal Webpage illustrating a library of target broadcast areas and a library of messages.

[0037] FIG. 10 is a screen shot of the Broadcast Agent Portal Webpage illustrating a Broadcast Agent Confirmation Entry prompt/window.

[0038] Corresponding reference characters indicate corresponding parts throughout the several views of the drawings.

DETAILED DESCRIPTION

[0039] The following description is merely exemplary in nature and is in no way intended to limit the invention, its application, or uses.

[0040] The public service message location broadcasting system (PLBS) according to one or more embodiments of the invention provide for an improved system and method for public service broadcast messaging. A public service message location broadcasting system (PLBS) operator provides a Broadcast Agent Web Portal or Webpage or other similar GUI interface, implementation and maintenance of the networks' cell-broadcast messaging components, networks and platforms, administration and operation of the public service message location broadcasting system, and interfaces to local telecommunication service providers including mobile unit service providers.

[0041] According to one embodiment in the event of a serious public emergency, a short text message is sent over the location broadcast channel. A mobile unit or Broadcast Agent phone which is configured to receive location broadcast messages, which is in the idle mode and which is located in the predefined cell receives the broadcast message and displays the message on its screen.

[0042] Location broadcasting is transmitted from the predefined cell in a downlink only mode and therefore does not require functionality or network resources

from the mobile services provider or from their any portion of the mobile service provider's mobility management resources, e.g., HLR, VLR, etc.

[0043] Public service message location broadcasting system provides for the simultaneous sending of public service messages to millions of subscribers with less impact on the supporting networks than a single SMS-message. As such, minimal to no network congestion will result.

[0044] A public service message location broadcasting system (PLBS) receives emergency or public service messaging and identification of the target broadcast area from public service or government entities. The PLBS provides location broadcast message enablement, security and multi-carrier interoperability and connectivity to the telecommunication service providers offering services within the target broadcast area.

[0045] A public service message location broadcasting system and method according to one or more embodiments provides for the development, transmission, delivery and display of a message that is an official government-to-citizen information broadcast to all compatible telecommunication receiving devices in, or entering, an predefined at-risk geographic location or area.

[0046] The PLBS system sends any public service or emergency information associated with any event, determined by authorized messaging entities that may affect public safety. These include utility outages, missing child alerts, severe weather warnings, flood warnings, and terrorist threat warnings. The messages are broadcast by public service message location broadcasting systems participating with local telecommunication networks.

[0047] Unlike other emergency messaging services that require the recipient's identity, a predetermined fixed delivery location, and usually the payment of a service fee, public service message location broadcasting system uses broadcast messaging technology to reach an unlimited number of people in real time, with no pre-event subscriber action required.

[0048] Public service message location broadcasting system uses cell-broadcast SMS (C-BSMS) technology to provide a message or alert to a single cell geographic location, a neighborhood, a city, or an entire nation with minimal impact to the hosting telecommunication networks.

[0049] Local telecommunications service providers such as mobile or cellular telephone service providers provide the local infrastructure and deployed

technologies to enable the service message location broadcasting system to transmit public messages in a timely manner to the public that may be at risk using a standard and commonplace mobile telephone unit.

[0050] The public service message location broadcast system and methods described herein provide the functions and steps necessary to ensure that the Broadcast Agents are authorized to send the requested broadcast messages to the defined broadcast target area. The PLBS configuration described herein provide for internal controls for insuring that the network and components are secure and that messages are authorized prior to transmittal. The public service message location broadcast system provides the interface to the Broadcast Agents to ensure simple and timely definition of the broadcast target area, the message and the authentication of the Broadcast Agent. The public service message location broadcast system also provides the interconnectivity and functionality for interface or the number telecommunication service providers which provide for the delivery of the broadcast message to the broadcast target area.

[0051] The public service message location broadcasting system consists of five parts:

1. Public Service Location Broadcast Service Bureau
2. Broadcast Agent Terminal/Web Portal/Web Page
3. Public Service Broadcast Controller
4. Carrier Broadcast Center
5. Public Service Location Broadcast Reporter

[0052] The Public Service Location Broadcast Service Bureau (PLB-SB) is located at a PLBS Operators location which is preferably secure. The PLBS-SB ensures the authenticity of the message and the authority of the sender to create such a message. Administrative Operators establish the User Profile in the Administration Subsystem to control Broadcast Agent rights and privileges. The signal from the Broadcast Agent Terminal, for example, at the police station, to the PLBS-SB, would only indicate the geographical area to be covered, plus the message. PLBS-SB then sends the broadcast request signal to the Carrier Broadcast Center at the office of each local carrier concerned.

[0053] PLBS-SB may also perform a billing gateway administrative function as may be required to allocate costs. PLBS-SB can utilize stored location

broadcast messaging data and may have access, in one embodiment, to the geographical coverage requested by the Public Service Broadcast Agent. PLBS-SB may be configured to determine or calculate population density of the broadcast area. PLBS-SB may also manage customer account data, authentication, security, and administration and application of restrictions on a customer, jurisdiction, or Broadcast Agent.

[0054] For each account, a Broadcast Agent Administrator is appointed. A person of whose authority is recognized, such as a police chief or city manager would be suitable for such a role, though he may likely delegate this to someone in the Information Technology services group. The Broadcast Agent Administrator (or his delegate) has under his control several Broadcast Agent accounts, which have authority under him, but on no account greater. For example, the jurisdiction of a Broadcast Agent is within that of a Broadcast Agent Administrator.

[0055] Using the PLBS-SB, an Administrative Operator checks and/or verifies the authenticity of the Broadcast Agent Administrator and defines or validates the jurisdictional area of the Broadcast Agent's organization. The Administrative Operator administers customer and agent profiles within the PLBS Service Bureau System. The Administrative Operator has secure access for administering the operational and administrative data and profiles for operation of the PLBS-SB. Best practices and Memoranda of Understanding (MOU) are defined by government agencies and/or local carriers. For example, a Coast Guard commander may have access only to coastal areas, though the area would be very large. In another example, a River Authority manager would have a guideline indicating that he could warn of imminent flooding, but not urge people to shower less. The river authority Jurisdiction may include only rivers, waterways and flood plains.

[0056] Any data and/or factor may be input to the PLBS-SB by the Administrative Operator and used by the PLBS-SB for system operation. Each Broadcast Agent Administrator has an account to which the Broadcast Agent belongs. The account is updated to indicate usage accumulated by the Broadcast Agent Administrator. Factors and data recorded include:

1. Language or Languages for warnings
2. Broadcast Agent Administrator account holder contact details
3. Total number of messages broadcast
4. Total Pops reached

5. Mess-Pops figure (number of messages times the pops reached)
6. Log, (Each broadcast is recorded on the account for later review)
7. Date of expiry of contract
8. Which networks are permitted for this Broadcast Agent Administrator?
9. Which channel numbers are allowed?
10. Message, Footprint and Broadcast libraries
11. Jurisdictional limits
12. Pop limits
13. Message length limits
14. Language for web portal
15. Report parameters and addresses
16. Admissions rules and operational events such as denials of service.

[0057] In some circumstances a report in the form of an e-mail or web-page may be sent or made available to the Administrative Operator and/or the Broadcast Agent Administrator. Such a report may include a warning that the account credit is about to expire, or the status of an account or activity. Such reports may be defined or requested or provided one a regular or specified interval.

[0058] Service may be automatically denied to a Broadcast Agent or Broadcast Agent Administrator who has exceeded his quota.

[0059] In other cases information about account status may be signaled to the Broadcast Agent at log on and when proposing messages. This may cause the Broadcast Agent to think again about conserving his quota if near to his limit.

[0060] The PLBS-SB may also define broadcast message jurisdiction is a geographical area for a particular Broadcast Agent Administrator and associated Broadcast Agents. Broadcast Message Jurisdiction may define any number of factors, data, or services. A first is definition or allocation of geographic territory or areas to be accessed or displayed in map format to the Broadcast Agents of the Broadcast Agent Administrator. Additional, all or a portion of the Broadcast Message Jurisdiction may be enabled or disabled for defining one or more broadcast message target areas or "Broadcast Target Area/Footprints" in which a public service broadcast message is to be sent. A second is the identification and specification of carrier or telecommunication local carriers that will be included in the public service location broadcast message messages originated by the particular Broadcast Agent

Administrator or Broadcast Agent. This may also include defining one or more networks, network components (such as Carrier Broadcast Center or network switching centers) or sub-networks to be provided the broadcast messages.

[0061] The Broadcast Agent Administrator is capable of setting further restrictions or rules related to its Broadcast Message Jurisdiction and one or more Broadcast Agents under its control or within its Broadcast Message Jurisdiction. For example, it may establish differ levels of authority for various personnel within a police department or fire department or allocation sub-areas or sub-jurisdictions based on police or fire department sub-boundaries.

[0062] For each Broadcast Agent Administrator, the Broadcast Target Area/Footprint Library is generated and shared among the Broadcast Agents. However in some cases, the Broadcast Agent Administrator may wish to pre-define Broadcast Target Area/Footprints on the basis of existing agreements. For example, these may include tornado watch boxes or mandated warning zones around a chemical plant.

[0063] In this case, the Broadcast Agent Administrator has the option to allow some Broadcast Agents only to access the Broadcast Target Area/Footprint library, or to be able to use the library and the map tool. Other Broadcast Agents may have the authority to create new Broadcast Target Area/Footprints and store them in the library.

[0064] In some cases, the Broadcast Target Area/Footprint area may be complex. An advanced Footprint Library feature will enable the Broadcast Agent to pre-define areas to be covered, and store them in a library of Broadcast Target Area/Footprints specific to that Broadcast Agent. For example, the flood plain area of a river may be complex to define with a simple mouse click. You would want to get that done ahead of time, then call it back quickly when an urgent message is imminent. In another case, a tornado warning box is pre-defined by political means and may be easier to refer to as such.

[0065] This feature may also be required if a particular Broadcast Agent only has authority to cover, for example, major highways or coastal areas such as beaches. These can be pre defined by an Administrative Operator and then locked so that the Broadcast Agent has limited authority as to the Broadcast Target Area/Footprint's area.

[0066] There is no limit on how many users one message can reach and in theory an authorized operator may send the message to everyone in the country at the same time. Since most authority is relatively limited, the account may be set established on a per Broadcast Agent basis thereby determining the area to be addressed by one message. An Admission Control feature checks new message for a pop figure before agreeing to proceed. If not, the message is declined and the Broadcast Agent receives a message and report with an explanation. To continue, the Broadcast Agent can either set the area to one less ambitious, or request authorization from another Broadcast Agent with more pop authority. The pop figure may also be used to generate usage statistics which the administration system would record for each Broadcast Agent. If a Broadcast Agent has exceeded the agreed limit, the account can be closed and an e-mail sent to the Broadcast Agent Administrator explaining this.

[0067] Control of Pops is also provided for the local carriers because the spacing of Radio Base Stations when very closely to population density. A dense urban area may be covered by more cells than the same corresponding area in a rural environment. From a signaling point of view more cells are signaled for an area in the city than in the country. Therefore the relationship between pops and network load is a valid one. For example, the number of messages times the population they have targeted [Mess*Pops] is one possible strategy for working out billing, since we have pop figures directly from the reports generated by account administration.

[0068] A Broadcast message may consist of 15 82-character messages linked together. The standard default maximum size of a message may be that used by second generation GSM systems, which is 93 characters, or 82 octets of data. However, in practice each message should be less in order to support multiple language messages and for practical application reasons. The Broadcast Agent Administrator may set limits on the length of an individual message. The Broadcast Agent Administrator may also set a limit on how much in total has been sent by all of the Broadcast Agents within his control. An extended-message button on the advanced message dialogue box provides for setting further message contents as required. For future systems, messages may include multimedia messages such as photographs or maps. In such a case, a multimedia facility dialogue box is utilized.

[0069] The Broadcast Agent Administrator may also pre-define set messages in the message library, so that some accounts may broadcast only these

messages. Others may be able to create their own and store them in the library. Past messages are also stored in the message library for later recall or repetition. Either from the advanced menu or from an advanced button on the quick message box, the Broadcast Agent can select the advanced message panel. Here the Broadcast Agent has many more options to control messages. For example, a particular message may be used frequently, or the precise wording of a message may have been agreed at higher political level in advance and only this wording is agreed. In such a case, the Broadcast Agent selects from a Message Library of standard messages available to this Broadcast Agent. The system stores past messages and is capable of retrieving them for re-transmission.

[0070] The system provides for the ability to repeat a message if the emergency continues for a long time, as the location broadcast message will only last for a limited period and be re-repeated. In other cases, the broadcast event may be triggered by an automatic machine such as a water level device. If so the event triggers the pre-defined message as set up by agreements ahead of time between the Broadcast Agent Administrator for that organization and the Administrative Operator who administers the accounts on the PLBS-SB in accordance with guidelines agreed with government authorities and local carriers.

[0071] A Broadcast Request includes both the message and the Broadcast Target Area/Footprint together. In some cases both the Broadcast Target Area/Footprint and the message may be pre defined by one group of Broadcast Agents giving other Broadcast Agents only the choice as to when to send the message. The Broadcast library also keeps copies of previously sent messages, and their Broadcast Target Area/Footprints, for fast recall and for internal management reasons within the Broadcast Agent organization.

[0072] The system also provides for the broadcasting of public messages that are in several languages. In this case the Broadcast Agent will not be allowed to proceed until messages in the other languages have been compiled. Alternatively the broadcast message may be sent in each language as each is entered. Otherwise translation servers can be signaled for a best effort translation. The account administration parameters will determine this.

[0073] In many cases, users may be travelers from an area where a different language is the primary language. If so, by keeping separate channels for warnings in each language, the user may receive a message in his own language. This

may also be required in multilingual countries or portions of countries such as along a border. The PLBS Operator or Broadcast Agent Administrator may also be required by government authorities to send messages in more than one language. If so, the Administration system reminds the Broadcast Agent to open up messages for all the languages required. It will then link them together so that when one is recalled, they are all recalled together and treated as if the same message.

[0074] The Broadcast Agent may not be able to read and write the message in the other language, for example, he may not read Chinese or Arabic. In this case, he can go to the library of messages, which will automatically match the other language message. However this restricts the message to those not containing any variables.

[0075] If the Broadcast Agent decides to recall a message from the network and order that its broadcast cease, the linkage will ensure that all languages are recalled at the same time.

[0076] The system also provides for the specification of how long a single broadcast continues to be broadcast. For example, for many situations a 20 minute broadcast may be long enough, after which a new command to send the message again is be initiated. The PLBS system may provide for a default time to be set in the Broadcast Agent account. Additionally, in the advanced menu options, the Broadcast Agent may be enabled to set start and stop time.

[0077] In other cases, Carriers or their networks may require that the broadcast message have a start time and stop time specified to the cell. The message is held at the cell and transmitted only when the start time arises, then transmission will be at regular intervals until the stop time arises, unless a command is received by the cell to cease the message. As such, the PLBS includes a default start time that is set by the PLBS-SB to be NOW, and the stop time to be 20 minutes. In some situations, the Broadcast Agent may have authority to set up messages for delivery at a pre-determined time in advance, or to set the broadcast time for a longer or shorter time. For example, the Broadcast Agent may be planning a highway shutdown, and may pre-program the night's messages accordingly. This frees manpower at the busy command center at the very moment when attention may be needed on the radio and elsewhere.

[0078] In the advanced message window, a start and stop time box may appear which is set to the defaults. The Broadcast Agent has the option to change

these, but as usual the administration system will check that the Broadcast Agent has authority to do so before proceeding with the message.

[0079] Channel codes define the type of message sent, which in turn defines the type of people being broadcasted to. The subscriber who owns the terminal has to switch on or off the channels at his discretion. The account will define which channel codes are defaults for this Broadcast Agent and which are allowed.

[0080] The Broadcast message is preceded by a channel code. Users may be given the option to select the type of messages they want to receive by going through a menu on their phone. Some mobile phones are sold with the default state set to disable the receipt of messages. However, to enable mass distribution of broadcast message, the channel numbers are defined for the various message types.

[0081] In any case, the Broadcast Agent may have another special need in mind other than to address the public for warnings. The Broadcast Agent may, for example, want to address only police officers or neighborhood watch volunteers in the area. In other instances, there may be automatic equipment in the area which needs to be commanded to perform in a certain way in some conditions and locations, for example, sirens to sound. If so, a different channel number is defined.

[0082] If the Broadcast Agent has the authority, the channel number may be changed. In the simple version, the default is the standard code for public safety messaging. In any case this code is checked against the Broadcast Agent profile by the Broadcast Agent Administrator before the message is sent to verify the authority of the Broadcast Agent.

[0083] In many areas, more than one official language is used. In such regions, people speaking one language, can be regularly crossing borders into countries which in themselves have multiple official languages, with primacy in different order. In other cases, such as the maritime service, information should be on the same code, regardless of which country the ship is in range of. Therefore, the system provides for the ability to transmit alert messages in all major official languages for a region. The system provides a mechanism to give the networks and governmental authorities flexibility in addressing this requirement.

[0084] Users may be required to turn one or more functions of their phone. The user may be motivated to do that if he knows that he will get messages in his language. If the user can speak more than one language, he can enable more than one code at his discretion. In addition, if the user is a tourist or traveling businessman, he

will get messages in his own language if that host country transmits them as such. For example, at airports, authorities may decide to transmit in English as well as the official languages, so as to warn passengers regardless if they speak the local language or not. Popular holiday resorts are another example.

[0085] Furthermore there may be politically sensitive positions regarding which language is the first and which the second. In one embodiment, pre-assigning codes according the internationally recognized order specified in ISO 639 may be implemented. The use of 145 codes covers most languages (plus some spare for special cases). However, a network may use the unused codes for another purpose. In any case since there are 1,000 codes available, this loss is a low price to pay in return for a good solution.

[0086] There are some cases where internationally agreed codes are required. One case in point is that of the maritime service channel. Many small pleasure craft and small coastal fishing vessels are not fitted with marine radio equipment. However in many cases one of the occupants of the boat does have a mobile unit in their possession. Certainly most large ships do have a GSM installation. If so the coastal authorities may decide to relay maritime safety information over a CB maritime service channel. If so, we could expect coastal shipping to switch on this channel. In that case, the channel number should be the same for every port the ship may visit, requiring an internationally assigned channel. In another example, the United Nations (UN) has the responsibility to care for the security concerns of all international relief workers working for them and any Non Governmental Organizations (NGOs). If the UN security -coordinator (UNSECORD) had a standard channel, then this highly mobile but very vulnerable group would be reachable on a geographically specific basis, but without having to change the channel number on their phone each time they change border. These two examples, while extreme, show the benefits of the current system for supporting multi-border Broadcast Agents.

[0087] One embodiment of a coding scheme consistent with the PLBS is provided in Appendix 1.

[0088] All broadcast messages are logged by the PLBS-SB in the logfile and cannot be tampered with by the Broadcast Agent or Administrative Operator. In the case of any dispute over a message, the Broadcast Agent Administrator, the

Administrative Operator, and/or a government authority may view the log to establish what has occurred.

[0089] This file may also be used for off line statistics and account administration. The reporting system may send a copy by e-mail to the Broadcast Agent and/or Broadcast Agent Administrators if required. In some cases billing can be derived from the message log and an off line billing gateway program which would use agreed information to derive billing.

[0090] The Broadcast Agent requires the permission of the local carrier to use their network for this purpose. The administration of individual accounts is provided to the Administrative Operator to define network guidelines for each Broadcast Agent Administrator. For each Broadcast Agent Administrator, the carriers who have agreed to carry his traffic are signaled individually. Broadcast Agent Administrator is provided with the ability to customize the interface between the various carriers to match the protocols or business requirements of the carriers.

[0091] The message is transmitted to the carrier for broadcast transmission over their network. In most cases, the message is transmitted by every known operator offering coverage of the area and may include mobile carriers, digital private radio systems operators, private radio system operators, internet providers, wireline telecommunication service providers, satellite service providers, CATV operators, etc.

[0092] The PLBS-SB sends a copy of the message and geographical information about the Broadcast Target Area/Footprint required to each operator's network center for further processing by the Carrier Broadcast Center (CBC) to determine which cells are involved, then send the signals to the correct switching center or Gateway platform. Some messages may be intended only for the private digital radio system used by the organization such as a police radio network. In other cases, sending a multimedia message such as a map or photo to a text-capable 2G network may not be applicable.

[0093] Carriers or telecommunications operators may decline to accept messages from a message source, or of a particular subject matter, context, or content. In each case, the networks which have been selected may be checked by an Administration Subsystem or Administrative Entity before the message is transmitted.

[0094] In some cases the sender may decide to recall the message before it has elapsed its time. In this case the Broadcast Agent will select the message from the

message library and press the recall button. Administration sends the recall command to the concerned networks or carriers.

[0095] Emergency situations are very dynamic, and the situation may change shortly after sending the message and before the expiry of the message time. If so, the PLBS provides the Broadcast Agent with the ability to recall the message. The system also includes a recall button to recall the message as displayed in the window. Each message is given a daily number for fast recall purposes.

[0096] The User may wish to know that the broadcast has indeed been passed to the networks for broadcasting. This can be by an e-mail or a report box on the browser.

[0097] Since the actual broadcast is managed by the local carrier through his network of gateways and switches, PLBS-SB cannot have any further influence on the process after the handoff to the network has been done. Therefore any progress information we can pass back is only valid up to the moment of handoff.

[0098] The report system can send a pop up window back to the Broadcast Agent provided he has not logged off the server by then. This can show ticks indicating that the message was handed off to network. However it does not indicate that the message is actually being transmitted at this time.

[0099] Optionally the report system can send an e-mail to the Broadcast Agent Administrator to inform him that messages have been sent. Should any irregularities occur or other trigger events, such as the near exhaustion of agreed messages, then a report can be sent to the Broadcast Agent Administrators e-mail reporting this.

[0100] Reports may be automatically generated as plain text messages and sent to an electronic address or e-mail account defined by the Broadcast Agent Administrator and/or Administrative Operator.

[0101] The Web Portal, as hosted directly or indirectly by the PLBS Service Bureau communicates with a Web Browser at the Broadcast Agent's location, as discussed below. The objective of the Portal is the creation of a Broadcast Request, a file which holds the following information.

- a. Broadcast Target Area/Footprint
- b. Broadcast Message and related parameters
- c. Broadcast Agent User ID and Password.

- d. Status of the Broadcast Request, (times Proposed, Authenticated, Handed off) and status reports.

[0102] The Admission Control Subsystem ensures that the proposed Broadcast Request by the particular Broadcast Agent at this time is authentic before passing it to the networks.

[0103] For the Broadcast Agent and session, the Portal provides an environment for the Broadcast Agent consisting of the maps of his jurisdiction and the Broadcast Target Area/Footprint, message and broadcast libraries that apply. Portal gets this information from the Account data. When the Multi-Language feature is required, appropriate windows will be provided in the message window.

[0104] Broadcast Agent Web Portal creates a Broadcast Request record with the name of being the current system date and time from when the Create Message button was pressed.

[0105] When the Broadcast Agent presses the GO-button, the Admission system fetches the Broadcast Agent profile from the account database. It will now check all the parameters of the Broadcast Agent and message to see if the message will be admitted or declined.

[0106] When a message is declined, the Broadcast Record is marked as such by its status register and sent to reporting; a report is then generated and e-mailed as per the parameters in the account data. The broadcast record is then stored along with the reports in the broadcast log. The Broadcast Agent creates a new broadcast which has a new number.

[0107] The Broadcast Agent ID and password details are then checked against the profile to authenticate the Broadcast Agent. If not authentic then the message is declined. Admission will then check the Broadcast Target Area/Footprint against the profile, If not within the Jurisdiction, and then the message will be declined. Admission will then calculate the Pops figure for this message by multiplying the area derived from the Broadcast Target Area/Footprint, by the population density. Population density figure is fetched from Account data. The [total messages], [Pop density], and [total mess*pop] figure is then fetched from the account data, and the new figure is added in the broadcast record but not written into the account data. The total result is checked against the limits set in account data. If the limit is exceeded then the admission rules are checked to see if the broadcast may

go ahead or not. If not then the message is declined. Alternatively a report may be generated according to the admission rules.

[0108] Multi language messaging checks may be performed to see if the Broadcast Agent has defined a message for each language as required by the government authorities. If not then the Broadcast may or may not be declined according to admission control rules.

[0109] The networks requested are checked against the Account Data. Portal may have defined networks that the account data has indicated, however in some cases some networks may accept some channels while others do not. If so, the broadcast may continue on the allowed networks and declined on others, or it may be declined altogether.

[0110] If Admission is satisfied that the Broadcast Request is valid, then it is sent to the distribution system.

[0111] The Admission control ensures that that any Broadcast Request meets with the approval based on preset guidelines. The parameters as to what is acceptable and what is not are set by the Administrative Operator in the Administration Data Base. Each registered Broadcast Agent, that is everyone who is allowed to create Broadcasts, has a separate Profile recorded in the Administration Database. Only the Administrative Operator has access to this file and can create, edit and delete Broadcast Agents. All Broadcast Agents belong to a Broadcast Agent Administrator, and may on no account have authority exceeding their Broadcast Agent Administrator.

[0112] The parameters used in the Administration Data Base are reviewed in the PLBS-SB System description document. There are other parameters about the User ID, the Broadcast Agent Administrator to whom the Broadcast Agent reports, and the current password and authentication key for each Broadcast Agent that may also be included.

[0113] The Administration subsystem is responsible for creating an object called the Broadcast Request. This file details everything known about each proposal. It also contains a check list of flags which are used by the system to track the progress of each Broadcast Request. A Broadcast Request is known by a unique ID consisting of the PLBS-SB which accepted the proposal, and the date time group identifying when it was accepted as a valid proposal.

[0114] When the Broadcast Agent presses the "propose" or "GO" button, Administration will check that the Broadcast Request has been created with enough required information, and is formatted correctly. When the Proposal is correctly formatted, it is recorded in the logfile data base, in an area where pending proposals are kept. The Administration system then orders the Admission control system to run.

[0115] Referring to Fig. X, the convention of having a yes answer coming out of the side, and a no answer from the bottom is applicable unless otherwise indicated.

[0116] Next Broadcast Agent - When activated, the Admission Control (admission) fetches the next Broadcast Agent from the logfile area where pending Broadcast Agents are waiting. The AC also copies all the parameters.

[0117] Fetch User Profile - The User ID is read and the Broadcast Agent profile is fetched from the Administration Data Base.

[0118] Security Fail - The User ID is checked against the password and authentication key entered in the database. (The Administration control system has validated the data link and network address of the originating terminal in the case of secure tunneling or Virtual Private Network or VPN access).

[0119] Security Report - If the security check fails, a short message explaining the reason for the failure is generated. The short message is appended to the report field for this Broadcast Request. In the case of a security offense or alert, additional data may be included such as details related to the attempted action.

[0120] All Decline Flags Set - To avoid a transmission of this Broadcast Agent, the Decline Flag is set for a Broadcast Request on all the network fields to restrict transmission.

[0121] Next Network - If there is no security problem, the Broadcast Request is examined to see which is the first network to be attempted. The Admission Parameters for this network will now be queried from the Administration Data Base and examined. When this is performed for all networks, a copy of the Broadcast Request is sent to the distributor system which converts the Broadcast Request into a signal for sending to the Carrier Broadcast Center at the Network management center. A communication protocol is used which may be a standard protocol or an application specific protocol such as a Broadcast Message Submission Protocol (BMSP)).

[0122] All Nets Done - The end of file marker is checked and read to determine whether all required networks have been analyzed. When all networks will have been signaled, a copy is transmitted to the Broadcast Agent.

[0123] Copy To Reporting - A copy of all Broadcasts and Broadcast Requests are written to or stored to the Broadcast Request reporting field that is sent to the reporting subsystem for transmission to the Broadcast Agent Administrator and to the Carrier Broadcast Centers or their reporting subsystem.

[0124] Copy to Logfile - The Broadcast Request is stored in the Logfile and deleted from the pending area.

[0125] Admiss Done - An Admiss Done flag or notification is set on the Broadcast Request record along with a timestamp indicating completion of the administration process.

[0126] Next Broadcast Agent Parameter - The Next Broadcast Agent parameter is retrieved from the Administration Data Base and compared to the requesting Broadcast Agent.

[0127] All Parameters Done - The All Parameters Done process ensures that all parameters have been evaluated and the file processing is near completion.

[0128] Fail? - The Fail process determines if a parameter in the Broadcast Request does not meet predefined criteria for a Broadcast Message as defined by the PLBS and/or of the Broadcast Agent Administrator.

[0129] Pass Report - If the parameter is within the predefined criteria, the reporting system appends to the Broadcast Request report a short message indicating which parameter has been passed. This provides for trouble shooting and resolving disputes.

[0130] Decline? - If the parameter under test does not fall within the predefined criteria, the parameter fails and special handing procedures are applied. Such procedures may enable a system override or an operator override such the Broadcast Request may continue even in light of the parameter within the predefined criteria. Such procedure may include checking the Decline parameter.

[0131] Warning Report - If the Decline Parameter is not met, a warning message is generated and appended to the Broadcast Request.

[0132] Warning Flag - A warning flag is set against the particular network.

[0133] Decline Report - If the Decline parameter indicates that the Broadcast Request is declined, a Decline Report is generated and appended to the Broadcast Request.

[0134] Decline Flag - A Decline Flag is set against that network upon indication of a Decline Parameter. A Decline Flag may apply to one or more networks as a function of the network facilities or arrangements.

[0135] Decline Flag set this Network - When all the parameters have been evaluated, the All Parameters Done message is returned. Prior to sending a Broadcast Request to a Broad Distributor for sending to the particular Carrier and Carrier's network or Carrier Broadcast Center (CBC), a determination of whether the Broadcast Request or message has been declined by the entity or system is determined. If the broadcast message has not been declined for the particular network, then the message is passed on.

[0136] Copy to Broadcast Request Distributor - A copy all or the relevant parts of the Broadcast Request is sent to the Broadcast Distributor or placed in a queue. The Broadcast Distributor may reformat the data according to one or more predefined parameters, formats or protocol associated with the transmission facility or link for communicating to the Carrier or the Carrier Broadcast Center (CBC).

[0137] Submission Report - A submission date and timestamp are appended to the report, and stored by the BLBS and/or Broadcast Agent Access Device. The process returns to the Next Network point so that the next network is evaluated since each network will have network specific criteria and parameters.

[0138] Using the Broadcast Agent Access Device, a Broadcast Agent defines the target area by drawing shapes or indicating areas on a map to where the broadcast message should be sent. As the target area will likely be served by two or more carriers or telecommunications service providers, the PLBS determines which carriers serve all or a portion of the target area. The PLBS may perform this function by a Broadcast Distributor which may be an integral system or module or a separate standalone system or module. It may be implemented in hardware or software. The Broadcast Distributor routes the broadcast message to the Carrier Broadcast Center (CBC) of the carriers providing service to all or a part of the target area as defined in the Broadcast Request. This may be implemented in any possible arrangement including a table, chart, or map.

[0139] Operators may in turn have different models of Carrier Broadcast Center (CBC), for example, the GMG 1.5, CellTech, or the Logica 1100, so a different mode of signaling for each type may be provided. One known industry standard protocol is BMSP. Administration data includes routing or address information for the appropriate Carrier Broadcast Center (CBC) interface unit, so that the appropriate signaling protocol conversion occurs.

[0140] Signaling to the CBC may utilize an industry standard BMSP protocol that defines the area polygons in WGS84 co-ordinates, the message, and associated scheduling information. The CBC provides a check of the proposed broadcast message for validity and converts the polygons into a Cell Identification (CellID) list. In one embodiment, the CBC sends the CellID list to the broadcast switching centers (BSC) by standard communication protocol such as the GSM 03.49 protocol/list. Transmission between PLBS-SB and CBC may utilize commercially available systems and facilities that may include TCP/IP secure tunneling protocols, or X25 as demanded by the local carrier.

[0141] When a PLBS Location Selector is provided at the carriers or local carrier's location, the Broadcast Request file may be transmitted by FTP/TCP/IP to the Location Selector for local processing into a Cell ID list before sending to the CBC or the BSC.

[0142] The Administrative Operator utilizes the system to designate administrative and operating parameters and profiles, authorizations, and restrictions for each Broadcast Agent Administrator. These may be based on government regulations, negotiated agreements, standards or policies and practices. This may include establishing schedule of authorizations for various Broadcast Agent Administrators and/or Broadcast Agents.

[0143] The Administrative Operator also establishes within the system an Administration Database to set account parameters so that Broadcast Agent Administrators and their Broadcast Agents have defined authorization levels. The Administrative Operator also uses the system to establish and maintain an account for each Broadcast Agent and Broadcast Agent Administrator for billing and administration purposes.

[0144] The system is configured to enable the Administrative Operator to resolve review Logfiles and Broadcast Requests. The system enables the Administrative Operator to read the logfiles, and to read and write to the

Administration Data Base. The Administrative Operator Management Subsystem is configured to provide the Administrative Operator with a web control panel or GUI environment in which to administer the User account data and system. Additionally the system is configured to generate statistics for administration, management, reporting, and billing.

[0145] A Location Broadcast Reporter may be configured to store broadcast messaging data and to prepare and produce reports related to past, pending, and future broadcast messages in one or more areas. The Location Broadcast Report may be located at a disaster management office, a control room, or the PLBS-SB. Access to such reports and data is made available to authorized personnel of the PLBS operator or an administrative or government entity. Such reports may be made in real-time via a web-based interface such that immediate action may be taken or additional or related actions may be initiated.

[0146] When the Admission Control Subsystem does not accept the Proposed Broadcast Request for any reason, a status message may be sent to the Broadcast Agent Access Device and a Report Required flag may be set. In such a case, reporting obtains the profile from the account data to determine the appropriate procedure.

[0147] Additionally, a notice or dialogue box may be opened at the Broadcast Agent Access Device to report the situation to the Broadcast Agent. If the Broadcast Agent has logged off the Broadcast Agent Access Device, a notification such as an email report is sent to the Broadcast Agent Administrator and the Broadcast Agent according to predefined addresses and arrangements. A copy of the report is also appended to the Broadcast Request to provide a record of the action.

[0148] Reporting also provides for reporting of any activity on the account to the Administrative Operator and Broadcast Agent Administrator. This includes reporting of any warnings that the account may expire. Reporting also sends account information to the Broadcast Agent Administrator on a regular basis depending on parameters defined in the account data. Reports are stored in the logfile which may be accessed by the Broadcast Administrative Operator.

[0149] A Broadcast Agent Terminal accessing the Broadcast Agent Portal or Webpage may be located at a Disaster Management Office such as a police control room. The authorized Broadcast Agent creates and proposes the message using a web

or internet browser, with web access, public service message location broadcasting system Direct, or the Public Service Location Broadcast Controller (PLBC).

[0150] The Broadcast Agent interacts with the PLBS-SB over a web page, (via a Web Portal); loading of special client software is unnecessary. Almost any computer can use PLBS-SB without any modification at all.

[0151] The Broadcast Agent accesses the Public Service Location Broadcast System (PLBS) via a communication network including the Internet and/or the World Wide Web. The Broadcast Agent device may be any communication device and is preferably one that is configured to access the Internet and/or to host a webpage. This includes a personal computer, laptop computer, mobile phone, and personal administrative device and variations thereof.

[0152] The Broadcast Agent device access a webpage or portal hosted directly or indirectly by the public service message location broadcasting system. Any current or future web, internet, or similar and future services browser or access method may be used by the Broadcast Agent. A standard language such as in one embodiment a Hyper Text Mark-up Language, HTML, may be utilized using any existing or future hardware and/or software platform. Standard, proprietary, and/or commercially available communications systems and protocols may be utilized to provide the various communications facilities and interconnections.

[0153] When added security is desired, commercially available or proprietary effective security protocols and measures such as SSL with public key encryption may be employed along with private networking facilities, Virtual Private Network (VPN) facilities, and/or secure tunneling features.

[0154] A Broadcast Agent Web Portal is made available throughout a LAN or an Internet to provide each and every Broadcast Agent with the flexibility of accessing the Public Service Message Location Broadcast System (PLBS) via any workstation wherever it may be located, including ones located at a home, remote office, or a portable computing computer, device or platform. The system may utilize wireless LANs such as the 802.11 technology and mobile Internet systems and networks.

[0155] The Broadcast Agent Web Portal is presented as a web page. The Broadcast Agent Webpage may be designed in a design configuration or pattern with an appearance of a control room or panel. Additionally, Broadcast Agent Webpage

may be consistent a Geographical Information System (GIS) service portal or webpage.

[0156] The Broadcast Agent Web Portal or Webpage may include or be composed of one or more maps with scroll bars and zoom options for easy and quick map viewing. One or more tool bars provide for Broadcast Agent with the ability to select and define a broadcast target area in a map format. While currently web browsers do not process Geographical Information System (GIS) data, the map may be a jpeg format image or file with conversions for position being performed by the PLBS-SB to aid the browser. However, it is expected that in the future the Broadcast Agent Web Portal or Webpage will directly support GIS map data, displaying, and definitional inputs.

[0157] The Homepage of the Broadcast Agent Webpage may present a map of the demonstration zone and a city or location name associated with the particular geographic area and/or the particular Broad Agent. In an alternative embodiment, the Homepage may display general data available to all users.

[0158] When a Broadcast Agent logs in, a map of the jurisdiction of that Broadcast Agent is displayed. The map is established by the Administrative Operator and/or the Broad Agent Administrator to prevent accidentally sending messages to an unrelated or unauthorized area.

[0159] The Broadcast Agent Web Portal or Webpage are designed to enable the sending or requesting of a Broadcast Request or message within six enters or "clicks" from the Broadcast Agent accessing the Web Portal. Similarly, the system is designed so that such actions are in a timely manner and may be accomplished in 15 seconds.

[0160] The Broadcast Agent utilizing the Broadcast Agent Webpage uses a pointing device such as a mouse or touchpad to define an area for which the message will be broadcast, e.g., the broadcast target area or Broadcast Target Area/Footprint. Preferably, the broadcast target area is defined by the Broadcast Agent through a graphical selection means such as clicking a mouse on the displayed map.

[0161] After the Broadcast Agent defines the broadcast target area, the Broadcast Agent initiates a message menu button on the menu bar and enters a message such as by typing a text message into a keyboard.

[0162] After this is complete, the Broadcast Agent authenticates the Broadcast Request through one or more authentication procedures. These may

include entering a User ID and Password, speaking a voice authentication message, or otherwise. After the Broadcast Request has been authenticated, the Broadcast Request is forwarded to the Public Service Location Broadcast System (PLBS) Service Bureau.

[0163] Optional system features may also be made available to the Broadcast Agent via the Broadcast Agent Web Portal or Webpage. These may be implemented as additional options on an Advanced button or the toolbar. These optional features may include:

- Broadcast Target Area/Footprint library
- Message library
- Multiple language messages
- Long messages
- Start time, Stop time
- Channel codes
- Recall messages
- Select networks
- Progress windows

[0164] The Broadcast Agent Web Portal and Webpage may provide one or more progress windows.

[0165] Once the Broadcast Agent has pressed the GO-button, and accepted liability for the message by typing his User ID and password, the message is not transmitted directly. Instead it is sent to the PLBS-SB's administrations subsystem where the Broadcast Agent is checked out for authority for this message. For example, the message has been defined for transmission within his jurisdiction. There may be restrictions on how many messages one individual or center may send in a period. This may be defined by the local carriers, government entities, or by the PLBS-SB operator.

[0166] Billing for the service may be done on the basis of the area that was defined for the message, or the population density assumed for the message. In each case the Broadcast Agent may want to know what the message is costing before deciding to proceed.

[0167] The Broadcast Agents request and message are checked over thoroughly by the administration subsystem to make sure of compliance to all

agreements, with the Broadcast Agent, the government authorities and the local carriers. Only in the case of full compliance does the message proceed. If so, a dialogue box confirms when each local carrier has accepted the message.

[0168] If not, then the Broadcast Agent will get a dialogue box explaining why the message was declined and a suggestion as to what to do next to get the message sent off quickly. For example, a smaller less ambitious Broadcast Target Area/Footprint may be tried, or perhaps authorization from a higher ranking Broadcast Agent.

[0169] Alternatively, when a web-based interface cannot handle a particular application or situation, the Advanced Broadcast Controller (PLBC) may provide this functionality. This third party application, can call on more, perhaps confidential information to define the broadcast area. In this way the confidential information never leaves the building.

[0170] At the local carrier's office, there is a Carrier Broadcast Center (CBC) server collates the cell Latitude and Longitude data received from the PLBS-SB with the locally provided Cell ID data for that carrier's network. A cell serving area map or table is derived from local carrier planning tool, systems, and data. Typically a carrier's engineering group prepares similar information for planning, maintenance and administration purposes.

[0171] Location broadcast messages are broadcast by the Cellular Network Operators on a per-cell basis over a location broadcast channel. In order to send a location broadcast message, a signal is sent to the Carrier Broadcast Center. From here, to the Base Station Controllers (BSC), containing the message to be transmitted, and crucially, the Global Cell IDs of the cells in which the broadcast is to be made, along with some other data such as how often and when the message is to be broadcast.

[0172] Cellular operators guard the information about their cells (the cell data) with great care, as the information can be useful to a competitor. They may find the prospect of having this information on multiple unsecured servers to be unacceptable.

[0173] According to one embodiment of the PLBS, each carrier maintains and controls access to their own proprietary network data including cell locations and cell serving areas. Each carrier receives geographic data defining the target area for the public service broadcast and determines which transmissions and transmitting

locations relate to the target area. Once established, each carrier initiates message broadcasting to only those locations or areas which relate in whole or in part to the target area. As such, competing carriers do not have access to other carrier's networks or proprietary network or customer data.

[0174] Transmission between PLBS-SB and CBC is achieved with available telecommunication facilities and protocols which may include TCP/IP secure tunneling protocols, security, and authentication. Transmission may be by wireline, wireless, including satellite facilities.

[0175] In one embodiment, the BLBS system ensures that the Carrier's cell data is retained by the Carrier in a look up table in the Carrier Broadcast Center at the Local carrier's office. This includes the Cell Identification Codes of the cells, the Latitude and Longitude positions of their respective Radio Base Station sites and azimuth data for their sectors. This leads to per-cell resolution, but for the first application this may be good enough considering the small size of modern cells, which are typically 1-3 Km across (about 2 miles). The cell data never leaves the Network's office. The local carrier such as a mobile service provider provides the hosting of the cell-broadcast messaging technology, access to the local cell network, and transmission of the cell-broadcast messages to its subscribers. Additionally, the carriers or mobile unit service providers may provide cell-site geographic coverage data either internally or to the PLBS operator to enable the operator GUI interface.

[0176] Location broadcast messages may be employed in several ways when numerous operators or carriers in a particular geographical area require the same information in a timely manner. Such information may include text messages relating to emergency situations, and, for 3G cells and phones, pictures of wanted or missing persons, graphical data, maps of problem areas including areas to avoid and escape routes.

[0177] Location broadcasting is a function of cellular networks and is defined by the official standardization bodies, such as GSM MoU, (GSM 03.41) UMTS, 3GPP/3GPP2 and IS95 CDMA. Many networks have location broadcast channels defined for their networks which are unused at present for lack of a suitable application.

[0178] There is typically more than one carrier or operator providing service in the same area. There is no co-ordination of cell planning between competing operators, and as such, the Cell layouts and Cell IDs of each are different. In addition,

due to constant improvements in telecommunication and cell coverage and capacity, the network design, and size and layout of geographic network systems and cells covering a particular area can be dynamic, e.g., network reconfigurations, cell splits and switch cutovers.

[0179] Also, many networks have a hierarchical network or cell structure system, with overlapping patterns of networks or cells of different sizes, such as Umbrella Cells, Macro Cells, Overlaid cells, Micro Cells and Pico cells. They may also have multiple layers of sub-band structure in different frequency bands such as (850-1900 or 900-1800-2Ghz, with each having different Cell IDs and different base station spacing.

[0180] Multi-network configurations will continue to increase in complexity with the introduction of 3G General Packet Radio Service (GPRS), EDGE, CDMA2000, and UMTS. 3G location broadcast messages will be much more capable, so different Cell ID tables are entered for a plain text version of the broadcast than for a multi-media version.

[0181] A single signal of about 1KB may be used by the Carrier for each transmission area or cell. The transceiver then carries out the repetition of the message for the time required.

[0182] User receiving devices may include mobile or cellular phones, PDA's, PC's, etc. Receiving devices may provide a distinct alert ring-tone that continues until the message is acknowledged by a local user. Such features and functions are dependent on the features and functionality of the various receiving devices. Some receiving devices may be configured to receive text messages, graphical data, images, and maps or may be capable of connecting to a designated website that provides additional information.

[0183] With one or more embodiments of the current system, special handsets or mobile unit units are not required. Global System for Mobile Communication (GSM) handsets may display a public service message location broadcasting system message as provided by a supporting GSM mobile service provider. Additionally, 3rd Generation mobile unit services providers and mobile unit or cellular devices will display location broadcast messages consistent with the public service message location broadcasting system.

[0184] A public service message location broadcasting service may also display a public service message location broadcasting system provider insignia or service mark.

[0185] Because public service message location broadcasting system is independent of the mobile unit service providers voice and SMS channels, cell-broadcasting will continue to operate during emergencies that result in high calling volume thereby enabling local authorities with a viable communications link for emergency instructions despite interruptions in voice and SMS service.

[0186] In operation, the public service message location broadcasting system may be provided, in one embodiment, by a method described herein. In the event of a need for a public service message broadcast, an authorized Broadcast Agent enters a password to access the public service message location broadcasting system via a Broadcast Agent System accessing a Broadcast Agent Web Portal from an Internet-attached device. The screen recognizes the Broadcast Agent and displays a map or illustration of his jurisdiction.

[0187] The Broadcast Agent defines or selects the target area which may be the entire authorized Broadcast Jurisdiction or may be a portion thereof. The Broadcast Agent constructs a text message indicating the nature of the emergency and/or required action. The Broadcast Agent specifies the length of time the message is to be broadcast and/or received by the receiving devices in the target area. The Broadcast Agent utilizing the Broadcast Agent System confirms and sends the data to the public service message location broadcasting system server.

[0188] The public service message location broadcasting system's Broadcast Data Management (BDM) server reformats the data and forwards it to the Carrier Broadcast Center for each of the telecommunication carriers providing service within the target area.

[0189] The Carriers Broadcast Center (CBC) selects one or more sub-networks and/or cell-sectors (such as transmission towers) that serve all or a portion of the target area so that the entire target area is covered by a broadcast. The CBC broadcast the message to all receiving devices within its serving area. The CBC broadcast transmission process is repeated for the duration of the alert to accommodate additional devices entering, becoming available, or being activated/powering-on within the target area. Receiving devices located within the

broadcast sub-networks or cells receive the public service broadcast message, and may provide an alert and display of the message.

[0190] In practice, operation of one or more embodiments may be described by the following example.

[0191] It is late at night and a river level is rising to dangerous levels. The local police want to warn the population at risk, the people who live in the area likely to flood. However since it is night time, they are not watching their televisions or listening to the radio. The senior police officer, or disaster manager, in the position of a Broadcast Agent accesses the public service message location broadcasting system web site that is located at a central site. The officer selects a map of the area that is in danger. The officer defines or selects a geographic broadcast target area to be notified of the danger. The officer enters a message indicating the nature of the danger and suggested actions such as FLOOD WARNING in your area. The officer initiates the broadcast messaging by following a security procedure and presses a Go-button.

[0192] The PLBS-SB receives the messages, performs a check on the validity of the officer as a Broadcast Agent that is proposing the message for the particular notification or broadcast target area. Once validated, the PLBS-SB sends messages to each of the telecommunication service providers or carrier having networks, coverage, or receiving units within the defined coverage area.

[0193] Each local telecommunication service provider receives the message and broadcast target area definitions from the broadcast system and initiates transmission of the broadcast message to the particular transmission networks serving the defined notification area. The local network of the telecommunication service provider broadcasts the message to every active compatible receiving unit active within the defined notification area. Each receiving unit receives the broadcast message and displays the message and may provide a common or unique alerting signal.

[0194] When introducing aspects of the invention or embodiments thereof, the articles "a", "an", "the", and "said" are intended to mean that there are one or more of the elements. The terms "comprising", "including", and "having" are intended to be inclusive and mean that there may be additional elements other than the listed elements.

[0195] In view of the above, it will be seen that several aspects of the invention are achieved and other advantageous results attained. As various changes

could be made in the above exemplary constructions and methods without departing from the scope of the invention, it is intended that all matter contained in the above description or shown in the accompanying drawings shall be interpreted as illustrative and not in a limiting sense.

[0196] It is further to be understood that the steps described herein are not to be construed as necessarily requiring their performance in the particular order discussed or illustrated. It is also to be understood that additional or alternative steps may be employed.

CLAIMS

What is claimed is:

1. A public service message broadcast system providing a broadcast message to a broadcast target area, the system comprising:

a broadcast agent webpage receiving broadcast agent input defining the broadcast target area and the broadcast message;

a carrier broadcast server transmitting the broadcast message to the broadcast target area; and

a broadcast service bureau hosting said broadcast agent webpage and coupled to said carrier broadcast server, said broadcast service bureau receiving the broadcast agent input and transmitting the broadcast message to the carrier broadcast server.

2. The system of claim 1 wherein the webpage provides a broadcast agent with geographic data.

3. The system of claim 3 wherein the geographic data is a map and wherein the target market area is defined as a function of the map.

4. The system of claim 1 wherein the broadcast service bureau transmits the broadcast target area to the carrier broadcast server.

5. The system of claim 1, further comprising a user receiving device, said carrier broadcast server transmitting the broadcast message to user receiving device located within the broadcast target area.

6. The system of claim 5 wherein the user receiving device is one of a personal computer, a wireline telephone, a pager, a mobile telephone, and a personal digital assistant device.

7. The system of claim 1 wherein the broadcast service bureau verifies an authority of the broadcast agent as a function of a broadcast agent authorization parameter, said transmitting the broadcast message being responsive to the authority verification.

8. The system of claim 1, further comprising a reporter module for reporting the broadcast message and the broadcast target area.

9. The system of claim 1, further comprising a broadcast controller providing a second broadcast agent interface for receiving broadcast agent input defining the broadcast target area and the broadcast message.

10. A public service message broadcast service bureau system providing a broadcast message to a broadcast target area, the system comprising:

a first communication interface coupled to a first network;

a second communication interface coupled to a second network;

a webpage receiving broadcast agent input defining the broadcast target area and the broadcast message; and

a computer hosting the webpage over the first communication interface, said computer receiving the broadcast agent input and transmitting the broadcast message to a local broadcast system over the second communication interface.

11. The system of claim 10 wherein the webpage provides a broadcast agent with geographic data.

12. The system of claim 11 wherein the geographic data is a map and wherein the target market area is defined as a function of the map.

13. The system of claim 10 wherein the computer transmits the broadcast target area to the local broadcast system over the second communication interface.

14. The system of claim 10 wherein the computer verifies an authority of the broadcast agent as a function of a broadcast agent authorization parameter, said transmitting the broadcast message to a local broadcast system being responsive to the authority verification.

15. A website interface system for a public service message broadcasting system comprising:

a broadcast agent device that includes a display for displaying a broadcast agent webpage; and

a webpage host that communicates with the broadcast agent device and that establishes a communications interface between the broadcast agent device and the webpage host;

said broadcast agent device receiving broadcast agent input defining the broadcast target area and the broadcast message, said broadcast agent device transmitting the broadcast target area and the broadcast message to the webpage host over the communication interface.

16. The system of claim 15 wherein the webpage provides a broadcast agent with geographic data.

17. The system of claim 16 wherein the geographic data is a map and wherein the target market area is defined as a function of the map.

18. The system of claim 17 wherein the webpage includes a shape tool for defining an irregular shaped broadcast target area.

19. The system of claim 15 wherein the broadcast agent device is one of a personal computer, a wireline telephone, a pager, a mobile telephone, and a personal digital assistant device.

20. A method of public service broadcast messaging to a broadcast target area, the method comprising:

hosting a broadcast agent webpage;

receiving a broadcast target area and a broadcast message from the broadcast agent webpage; and

transmitting the broadcast message to the broadcast target area.

21. The method of claim 20, further comprising receiving broadcast agent input via the hosted webpage.

22. The method of claim 20, further comprising transmitting the broadcast message to a carrier broadcast server that transmits the broadcast message to the broadcast target area.

23. The method of claim 22, further comprising transmitting the broadcast target area to the carrier broadcast server.

24. The method of claim 20 wherein the broadcast agent webpage provides a broadcast agent with a map.

25. The method of claim 23 wherein the broadcast agent webpage enables the broadcast agent to define a broadcast target area with an irregular shape.

26. The method of claim 20, further comprising receiving the broadcast message at a user receiving device as a function of the user receiving device being located within the broadcast target area.

27. The method of claim 20, further comprising verifying an authority of a broadcast agent accessing the broadcast agent webpage and generating the broadcast message, wherein said verifying is a function of a broadcast agent authorization parameter.

28. The method of claim 27 wherein the authorization parameter is a geographic parameter defining an authorized broadcast agent broadcasting area.

29. The method of claim 27 wherein transmitting the broadcast message to the broadcast target area is responsive to the authority verification.

30. The method of claim 1, further comprising transmitting a report containing the broadcast message and the broadcast target area to a reporting system.

Appendix 1: Code channel assignments

500 common training, exercise and test channel.	555 hy Armenian
501-650 Languages listed in order according to ISO 639.	556 ia Interlingua
501 aa Afar	557 ie Interlingue
502 ab Abkhazian	558 ik Inupiak
503 af Afrikaans	559 in Indonesian
504 am Amharic	560 is Icelandic
505 ar Arabic	561 it Italian
506 as Assamese	562 iw Hebrew
507 ay Aymara	563 ja Japanese
508 az Azerbaijani	564 ji Yiddish
509 ba Bashkir	565 jw Javanese
510 be Byelorussian	566 ka Georgian
511 bg Bulgarian	567 kk Kazakh
512 bh Bihari	568 kl Greenlandic
513 bi Bislama	569 km Cambodian
514 bn Bengali, Bangla	570 kn Kannada
515 bo Tibetan	571 ko Korean
516 br Breton	572 ks Kashmiri
517 ca Catalan	573 ku Kurdish
518 co Corsican	574 ky Kirghiz
519 cs Czech	575 la Latin
520 cy Welsh	576 ln Lingala
521 da Danish	577 lo Laothian
522 de German	578 lt Lithuanian
523 dz Bhutani	579 lv Latvian, Lettish
524 el Greek	580 mg Malagasy
525 en English	581 mi Maori
526 eo Esperanto	582 mk Macedonian
527 es Spanish	583 ml Malayalam
528 et Estonian	584 mn Mongolian
529 eu Basque	585 mo Moldavian
530 fa Persian	586 mr Marathi
531 fi Finnish	587 ms Malay
532 fj Fiji	588 mt Maltese
533 fo Faeroese	589 my Burmese
534 fr French	590 na Nauru
535 fy Frisian	591 ne Nepali
536 ga Irish	592 nl Dutch
537 gd Scots Gaelic	593 no Norwegian
538 gl Galician	594 oc Occitan
539 gn Guarani	595 om (Afan) Oromo
540 gu Gujarati	596 or Oriya
541 ha Hausa	597 pa Punjabi
542 hi Hindi	598 pl Polish
543 hr Croatian	599 ps Pashto, Pushto
544 hu Hungarian	600 pt Portuguese
	601 qu Quechua
	602 rm Rhaeto-Romance

603 rn Kirundi	672 Aeronautical service channels.
604 ro Romanian	673 Amateur service channels.
605 ru Russian	674 Scientific services.
606 rw Kinyarwanda	690-699 UN and International Organisations. E.G.
607 sa Sanskrit	690 UNSECORD (UN Security Co-Ordinator.)
608 sd Sindhi	691 UNICEF (Child security)
609 sg Sangro	692 WFP
610 sh Serbo-Croatian	693 WHO
611 si Singhalese	694 UNHCR
612 sk Slovak	695 OCHA
613 sl Slovenian	696 Red Cross/ Crescent Movement.
614 sm Samoan	
615 sn Shona	
616 so Somali	
617 sq Albanian	
618 sr Serbian	
619 ss Siswati	
620 st Sesotho	
621 su Sundanese	
622 sv Swedish	
623 sw Swahili	
624 ta Tamil	
625 te Tegulu	
626 tg Tajik	
627 th Thai	
628 ti Tigrinya	
629 tk Turkmen	
630 tl Tagalog	
631 tn Setswana	
632 to Tonga	
633 tr Turkish	
634 ts Tsonga	
635 tt Tatar	
636 tw Twi	
637 uk Ukrainian	
638 ur Urdu	
639 uz Uzbek	
640 vi Vietnamese	
641 vo Volapuk	
642 wo Wolof	
643 xh Xhosa	
644 yo Yoruba	
645 zh Chinese	
646 zu Zulu	
646-669 locally specified purpose or language.	
670-699 International alert channels.	
671 Maritime service channel.	

Other channels at the discretion of the networks, and in conjunction with the governmental authorities and other interested parties.

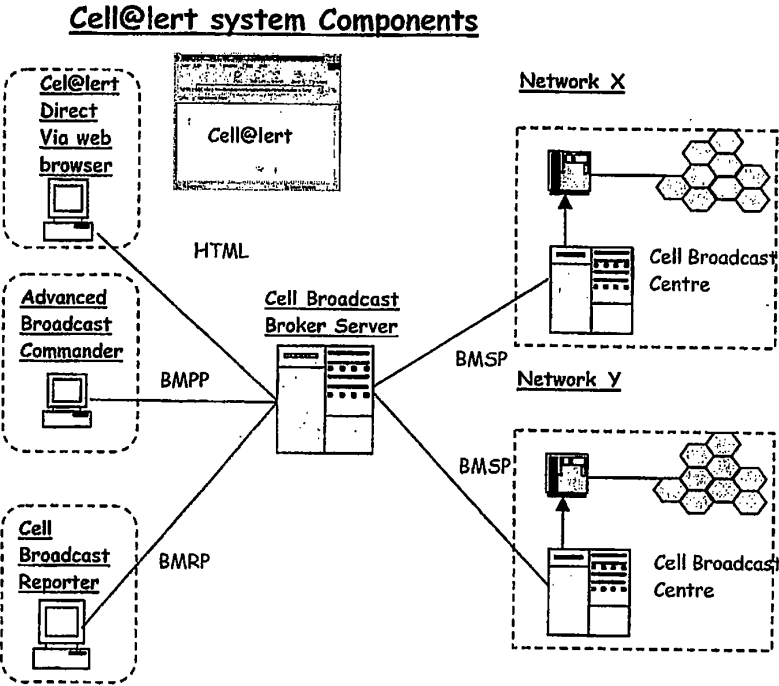

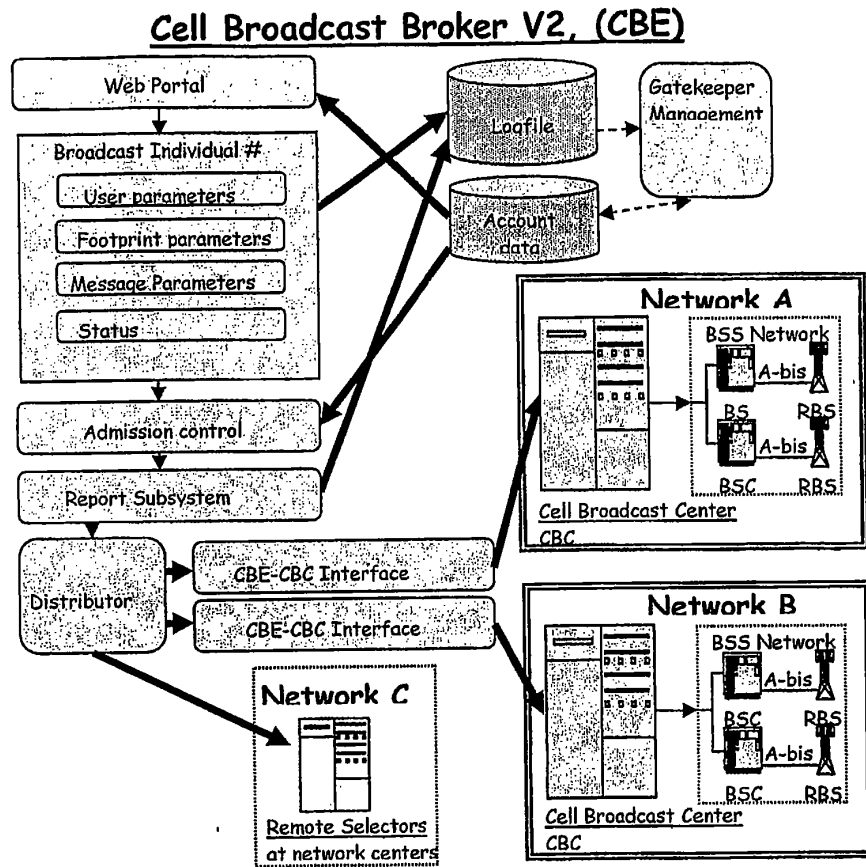

FIG. 2

CBB Admission Control Algorithm

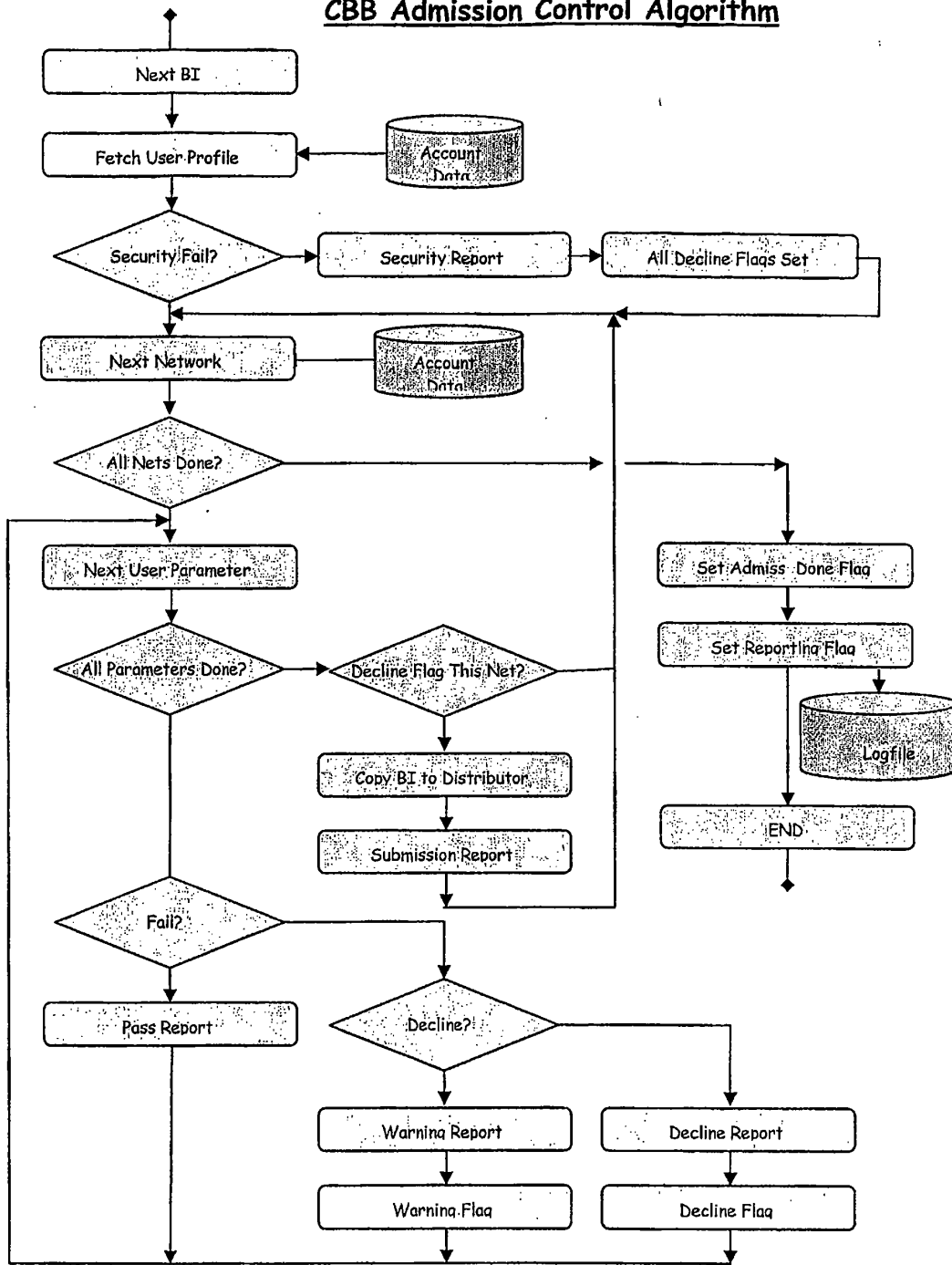

FIG. 3

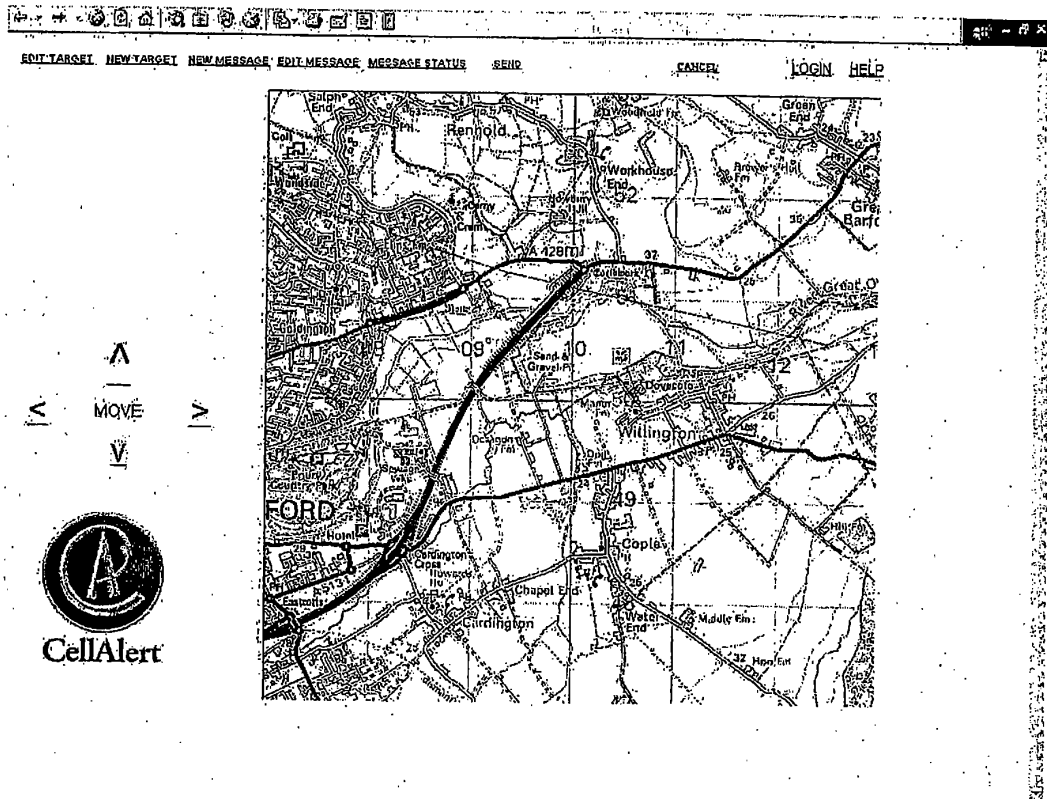

Fig. 4. The Web Portal. The Graphical User Interface (GUI) can be provided by the Web Portal or the Advanced Broadcast Controller (ABC). This shows the appearance of the Web Portal. The user will have first entered his userID and password before this point. The system then knows which maps to show the user, according to his jurisdiction.

FIG. 4

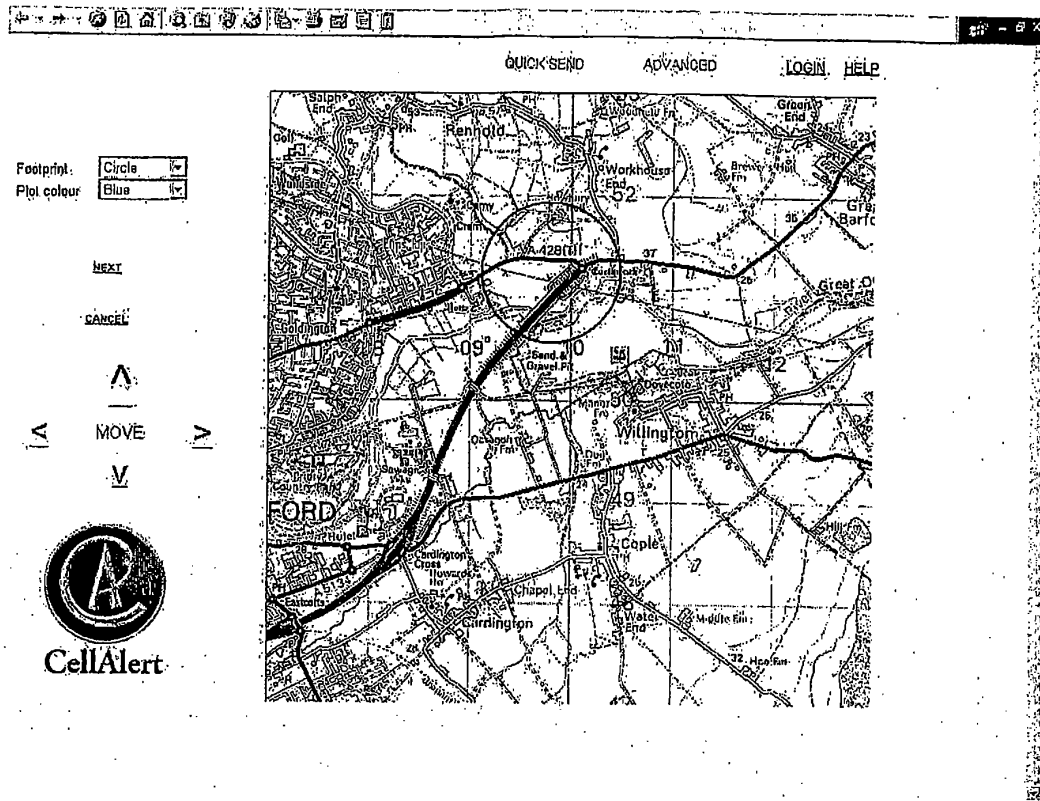

Fig 5. The user may now use the move buttons to scroll the map, and select a scale. He then used the Draw tool to point and click the mouse to create an area known as the 'Footprint', the area where the broadcast will be sent.

FIG. 5

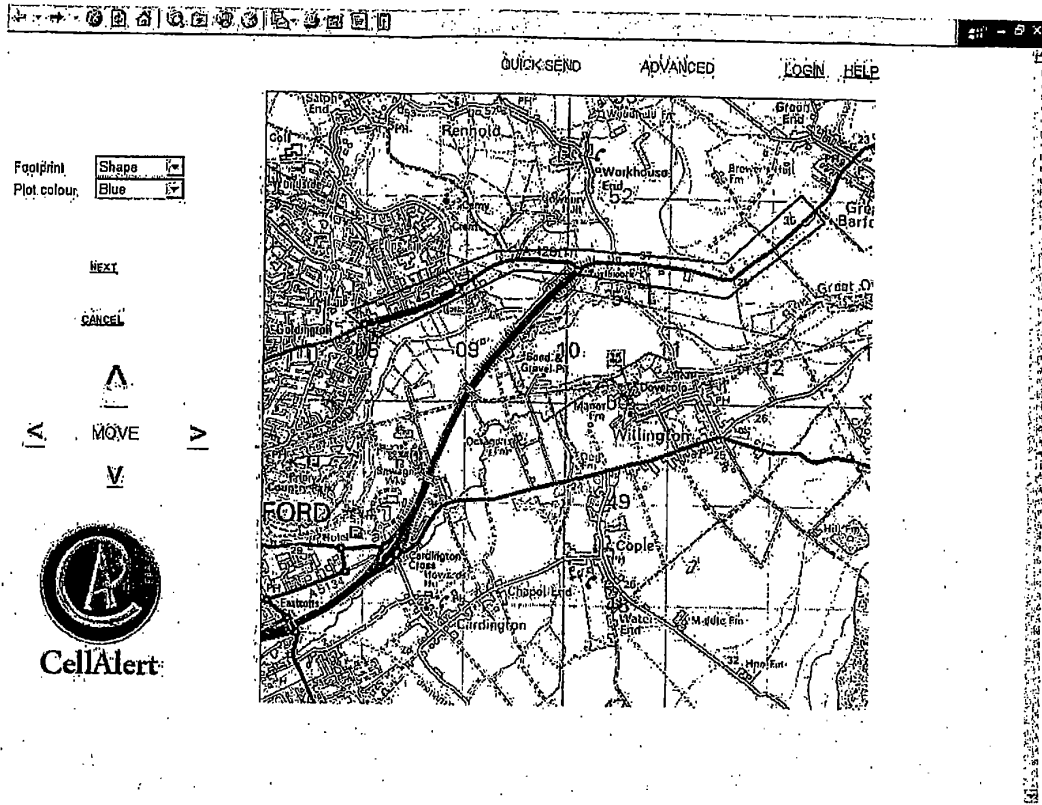

Fig. 6. A Shape tool can be used to define an irregular polygon as the Footprint. Such footprints can also be saved into a footprint library for later recall.

FIG. 6

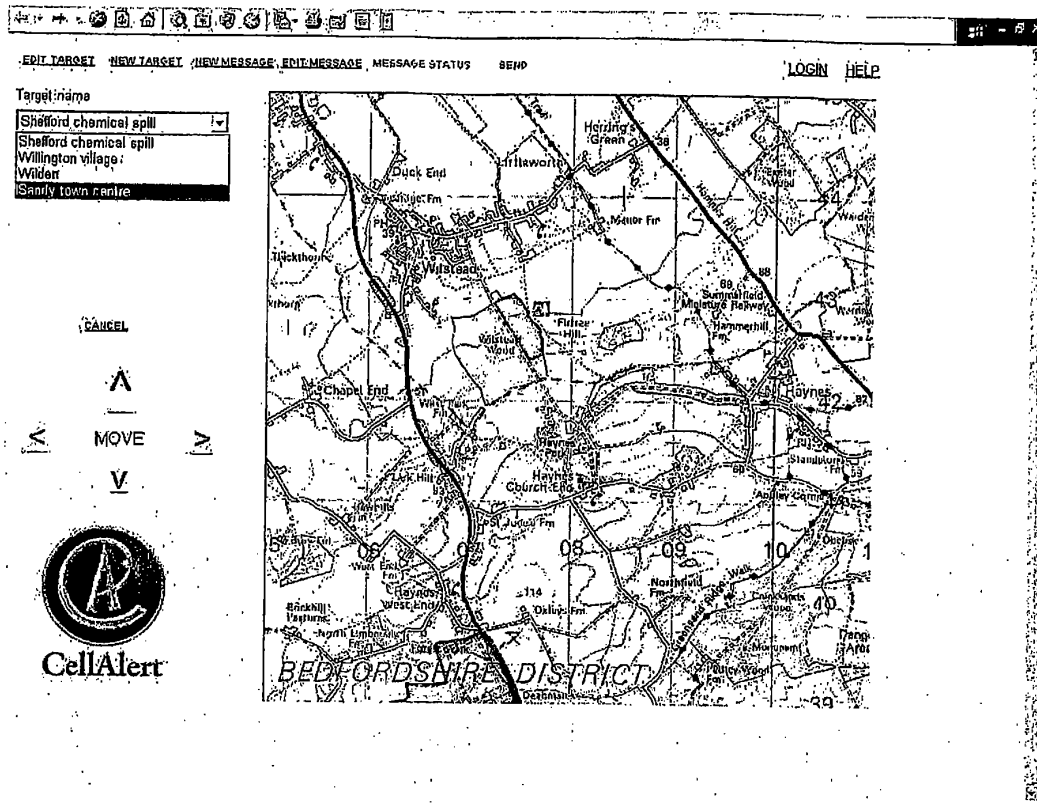

Fig. 7. A library of Footprints can be recalled to speed up footprint design, or to follow senior management directions.

FIG. 7

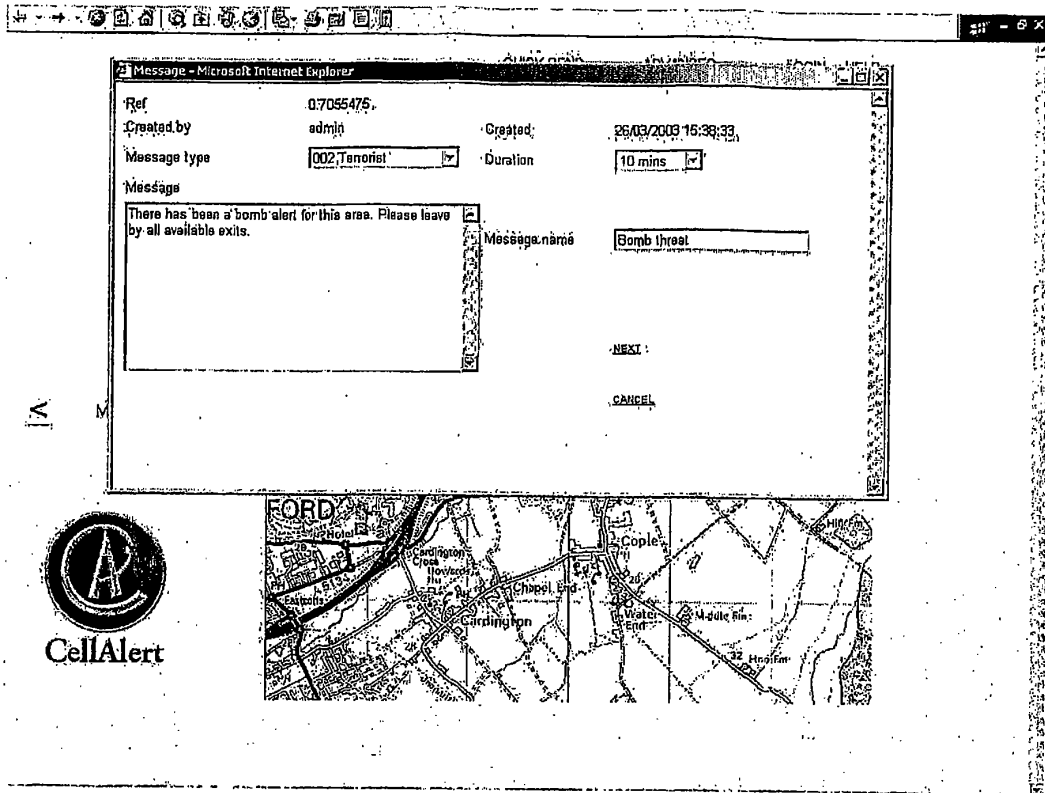

Fig 8. Once the footprint is defined, a dialogue box opens showing options that this user has. These are defined in the contract that the super user (his boss) has with CellAlert. Here he enters the text of the message, its channel number (this may be fixed) and the duration of the broadcast.

FIG. 8

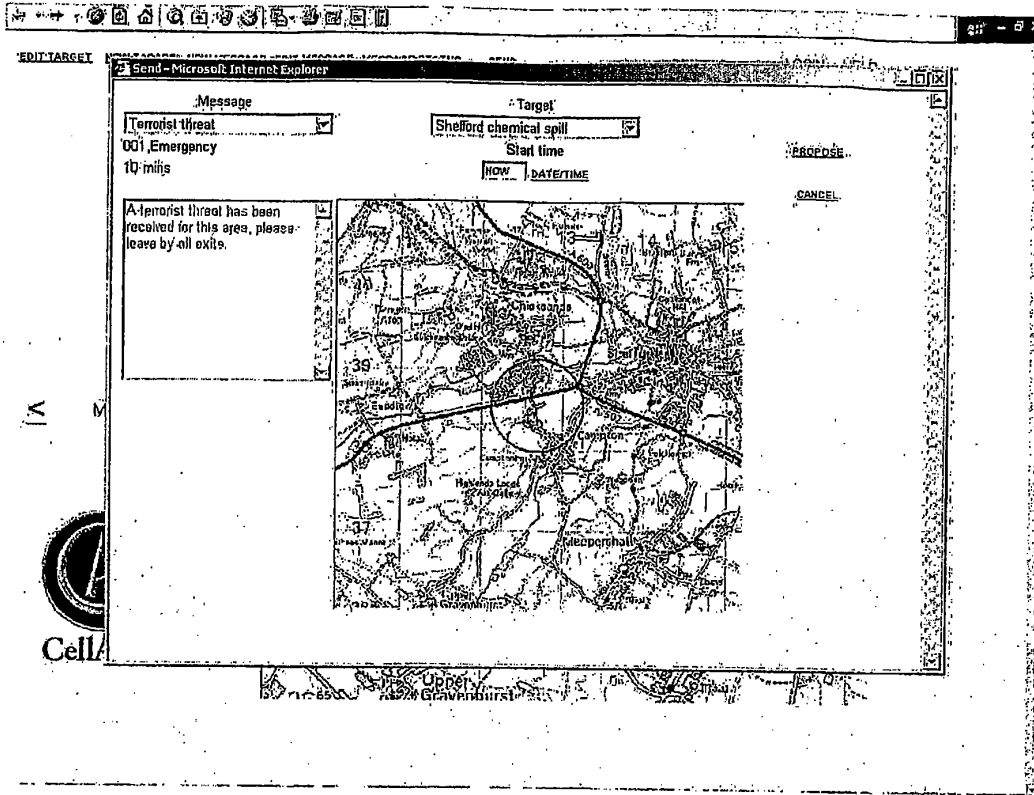

Fig. 9. In some cases a standard library message including both the footprint and the message may be recalled. This is for speed and so that lower ranking officers can act without exceeding their authority.

FIG. 9

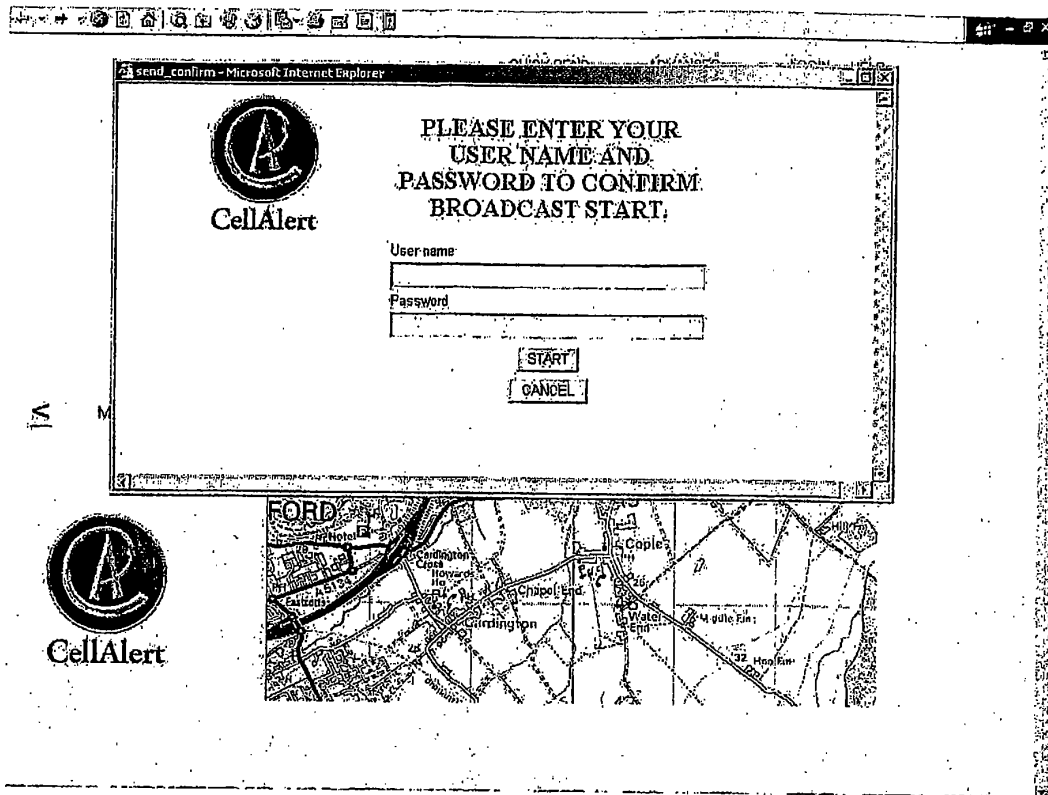

Fig. 10. When the Broadcast is defined, the user is asked to confirm his UserID and a special authentication key. By pressing the start button this broadcast becomes a 'Proposal'. However it will not be broadcast until it has been passed by admission control.

FIG. 10

(19) World Intellectual Property Organization
International Bureau



(43) International Publication Date
1 September 2005 (01.09.2005)

PCT

(10) International Publication Number
WO 2005/079421 A3

- (51) International Patent Classification:
G06F 15/16 (2006.01)
- (21) International Application Number:
PCT/US2005/004897
- (22) International Filing Date:
14 February 2005 (14.02.2005)
- (25) Filing Language: English
- (26) Publication Language: English
- (30) Priority Data:
60/544,739 13 February 2004 (13.02.2004) US
- (71) Applicants and
(72) Inventors: WEISER, Douglas, D. [US/US]; 623 Lakeview Road, Lake St. Louis, MO 63376 (US). PRESTON, Kevin, R. [GB/GB]; Nant-y-Ciesaid Farm, Penllwyn Lane Machen, Gwent, CF83 8 RL (GB). WOOD, Mark, Andrew [GB/GB]; 3 Lion Lane, Haslemere,, Surrey, GU27 1JF (GB).
- (74) Agents: WHEELOCK, Bryan, K. et al.; Harness, Dickey & Pierce, P.L.C., Suite 400, 7700 Bonhomme Avenue, St. Louis, MO 63105 (US).
- (81) Designated States (unless otherwise indicated, for every kind of national protection available): AE, AG, AL, AM, AT, AU, AZ, BA, BB, BG, BR, BW, BY, BZ, CA, CH, CN, CO, CR, CU, CZ, DE, DK, DM, DZ, EC, EE, EG, ES, FI, GB, GD, GE, GH, GM, HR, HU, ID, IL, IN, IS, JP, KE, KG, KP, KR, KZ, LC, LK, LR, LS, LT, LU, LV, MA, MD, MG, MK, MN, MW, MX, MZ, NA, NI, NO, NZ, OM, PG, PH, PL, PT, RO, RU, SC, SD, SE, SG, SK, SL, SM, SY, TJ, TM, TN, TR, TT, TZ, UA, UG, US, UZ, VC, VN, YU, ZA, ZM, ZW.
- (84) Designated States (unless otherwise indicated, for every kind of regional protection available): ARIPO (BW, GH, GM, KE, LS, MW, MZ, NA, SD, SL, SZ, TZ, UG, ZM, ZW), Eurasian (AM, AZ, BY, KG, KZ, MD, RU, TJ, TM), European (AT, BE, BG, CH, CY, CZ, DE, DK, EE, ES, FI, FR, GB, GR, HU, IE, IS, IT, LT, LU, MC, NL, PL, PT, RO, SE, SI, SK, TR), OAPI (BF, BJ, CF, CG, CI, CM, GA, GN, GQ, GW, ML, MR, NE, SN, TD, TG).
- Published:
— with international search report
— before the expiration of the time limit for amending the claims and to be republished in the event of receipt of amendments

[Continued on next page]

(54) Title: PUBLIC SERVICE MESSAGE BROADCASTING SYSTEM AND METHOD

Cell@lert system Components

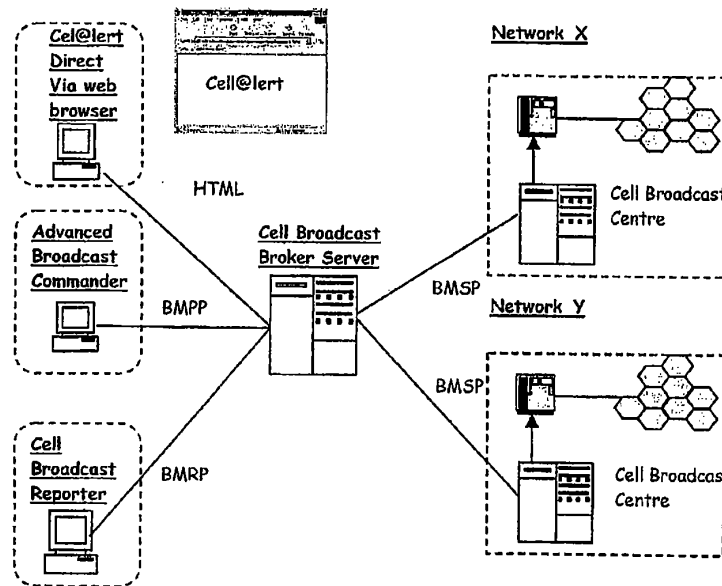

(57) Abstract: The public service message location broadcast system and method provides for broadcasting a message to communication receiving devices located within a defined geographic broadcast target area. The broadcast target area is defined by a broadcast agent using a broadcast agent webpage and a broadcast service bureau transmits the broadcast message to one or more local carriers who provide telecommunication service to the broadcast target area. The local carrier transmits the broadcast message to targeted users within the broadcast target area.

WO 2005/079421 A3



(88) Date of publication of the international search report:
21 September 2006

For two-letter codes and other abbreviations, refer to the "Guidance Notes on Codes and Abbreviations" appearing at the beginning of each regular issue of the PCT Gazette.

INTERNATIONAL SEARCH REPORT

International application no.

PCT/US05/04897

<p>A. CLASSIFICATION OF SUBJECT MATTER IPC: G06E 15/16</p> <p>USPC: 709/206 According to International Patent Classification (IPC) or to both national classification and IPC</p>																						
<p>B. FIELDS SEARCHED</p> <p>Minimum documentation searched (classification system followed by classification symbols) U.S. : 709/206</p> <p>Documentation searched other than minimum documentation to the extent that such documents are included in the fields searched</p> <p>Electronic data base consulted during the international search (name of data base and, where practicable, search terms used)</p>																						
<p>C. DOCUMENTS CONSIDERED TO BE RELEVANT</p> <table border="1"> <thead> <tr> <th>Category *</th> <th>Citation of document, with indication, where appropriate, of the relevant passages</th> <th>Relevant to claim No.</th> </tr> </thead> <tbody> <tr> <td>Y</td> <td>US 2002/0107016 A1 (HANLEY) 08 August 2002 (08.08.2002), figure 1, paragraphs 0025-0030</td> <td>1-30</td> </tr> <tr> <td>Y</td> <td>US 6,219,696 B1 (WYNBLATT et al) 17 April 2001 (17.04.2001), column 2-4.</td> <td>1-30</td> </tr> <tr> <td>Y</td> <td>US 6,240,360 B1 (PHELAN) 29 May 2001 (29.05.2001), figures 1-3, column 4-7</td> <td>3, 7, 12, 14, 17-18, 24-25, 27-29</td> </tr> </tbody> </table>			Category *	Citation of document, with indication, where appropriate, of the relevant passages	Relevant to claim No.	Y	US 2002/0107016 A1 (HANLEY) 08 August 2002 (08.08.2002), figure 1, paragraphs 0025-0030	1-30	Y	US 6,219,696 B1 (WYNBLATT et al) 17 April 2001 (17.04.2001), column 2-4.	1-30	Y	US 6,240,360 B1 (PHELAN) 29 May 2001 (29.05.2001), figures 1-3, column 4-7	3, 7, 12, 14, 17-18, 24-25, 27-29								
Category *	Citation of document, with indication, where appropriate, of the relevant passages	Relevant to claim No.																				
Y	US 2002/0107016 A1 (HANLEY) 08 August 2002 (08.08.2002), figure 1, paragraphs 0025-0030	1-30																				
Y	US 6,219,696 B1 (WYNBLATT et al) 17 April 2001 (17.04.2001), column 2-4.	1-30																				
Y	US 6,240,360 B1 (PHELAN) 29 May 2001 (29.05.2001), figures 1-3, column 4-7	3, 7, 12, 14, 17-18, 24-25, 27-29																				
<p><input type="checkbox"/> Further documents are listed in the continuation of Box C. <input type="checkbox"/> See patent family annex.</p>																						
<p>* Special categories of cited documents:</p> <table border="0"> <tr> <td>"A"</td> <td>document defining the general state of the art which is not considered to be of particular relevance</td> <td>"T"</td> <td>later document published after the international filing date or priority date and not in conflict with the application but cited to understand the principle or theory underlying the invention</td> </tr> <tr> <td>"E"</td> <td>earlier application or patent published on or after the international filing date</td> <td>"X"</td> <td>document of particular relevance; the claimed invention cannot be considered novel or cannot be considered to involve an inventive step when the document is taken alone</td> </tr> <tr> <td>"L"</td> <td>document which may throw doubts on priority claim(s) or which is cited to establish the publication date of another citation or other special reason (as specified)</td> <td>"Y"</td> <td>document of particular relevance; the claimed invention cannot be considered to involve an inventive step when the document is combined with one or more other such documents, such combination being obvious to a person skilled in the art</td> </tr> <tr> <td>"O"</td> <td>document referring to an oral disclosure, use, exhibition or other means</td> <td>"&"</td> <td>document member of the same patent family</td> </tr> <tr> <td>"P"</td> <td>document published prior to the international filing date but later than the priority date claimed</td> <td></td> <td></td> </tr> </table>			"A"	document defining the general state of the art which is not considered to be of particular relevance	"T"	later document published after the international filing date or priority date and not in conflict with the application but cited to understand the principle or theory underlying the invention	"E"	earlier application or patent published on or after the international filing date	"X"	document of particular relevance; the claimed invention cannot be considered novel or cannot be considered to involve an inventive step when the document is taken alone	"L"	document which may throw doubts on priority claim(s) or which is cited to establish the publication date of another citation or other special reason (as specified)	"Y"	document of particular relevance; the claimed invention cannot be considered to involve an inventive step when the document is combined with one or more other such documents, such combination being obvious to a person skilled in the art	"O"	document referring to an oral disclosure, use, exhibition or other means	"&"	document member of the same patent family	"P"	document published prior to the international filing date but later than the priority date claimed		
"A"	document defining the general state of the art which is not considered to be of particular relevance	"T"	later document published after the international filing date or priority date and not in conflict with the application but cited to understand the principle or theory underlying the invention																			
"E"	earlier application or patent published on or after the international filing date	"X"	document of particular relevance; the claimed invention cannot be considered novel or cannot be considered to involve an inventive step when the document is taken alone																			
"L"	document which may throw doubts on priority claim(s) or which is cited to establish the publication date of another citation or other special reason (as specified)	"Y"	document of particular relevance; the claimed invention cannot be considered to involve an inventive step when the document is combined with one or more other such documents, such combination being obvious to a person skilled in the art																			
"O"	document referring to an oral disclosure, use, exhibition or other means	"&"	document member of the same patent family																			
"P"	document published prior to the international filing date but later than the priority date claimed																					
<p>Date of the actual completion of the international search 12 June 2006 (12.06.2006)</p>		<p>Date of mailing of the international search report 17 JUL 2006</p>																				
<p>Name and mailing address of the ISA/US Mail Stop PCT, Attn: ISA/US Commissioner for Patents P.O. Box 1450 Alexandria, Virginia 22313-1450 Facsimile No. (571) 273-3201</p>		<p>Authorized officer <i>Zami Maung</i> Telephone No. (571) 272-1400</p>																				

Form PCT/ISA/210 (second sheet) (April 2005)

(19)



Europäisches Patentamt

European Patent Office

Office européen des brevets



(11)

EP 0 915 598 A2

(12)

EUROPEAN PATENT APPLICATION

(43) Date of publication:
12.05.1999 Bulletin 1999/19

(51) Int. Cl.⁶: H04L 29/06, H04L 12/56,
H04L 12/18

(21) Application number: 98118038.3

(22) Date of filing: 23.09.1998

(84) Designated Contracting States:
AT BE CH CY DE DK ES FI FR GB GR IE IT LI LU
MC NL PT SE
Designated Extension States:
AL LT LV MK RO SI

(72) Inventor: Bushmitch, Dennis
Summit, New Jersey 07901 (US)

(30) Priority: 30.10.1997 US 960799

(74) Representative:
Lindner, Michael, Dipl.-Ing. et al
Patentanwälte,
Witte, Weller & Partner,
Rotebühlstrasse 121
70178 Stuttgart (DE)

(71) Applicant:
MATSUSHITA ELECTRIC INDUSTRIAL CO., LTD.
Osaka 571 (JP)

(54) Distributed internet protocol-based real-time multimedia streaming architecture

(57) Multiple media push engines communicate with the multimedia client through a multi casting network that may incorporate multiple delivery paths. The streaming data representing media selections for delivery are distributed across multiple media push engines using a non-hierarchical coding technique in which the data are represented as a set of substream components, capable of being reconstituted from fewer than all of the components of the original data stream. The higher the number of components used in reconstitution, the higher the quality of service is provided by the

reconstituted stream. Admission control to the group multicast session is administered in a distributed fashion, where an admission control unit opens the multicast stream, with all subsequent admission control decisions being made by the media push engines themselves. Substream component data are sent using Real-Time transport protocol while session management and the distributed admission control process are administered under the Real-Time Control Protocol.

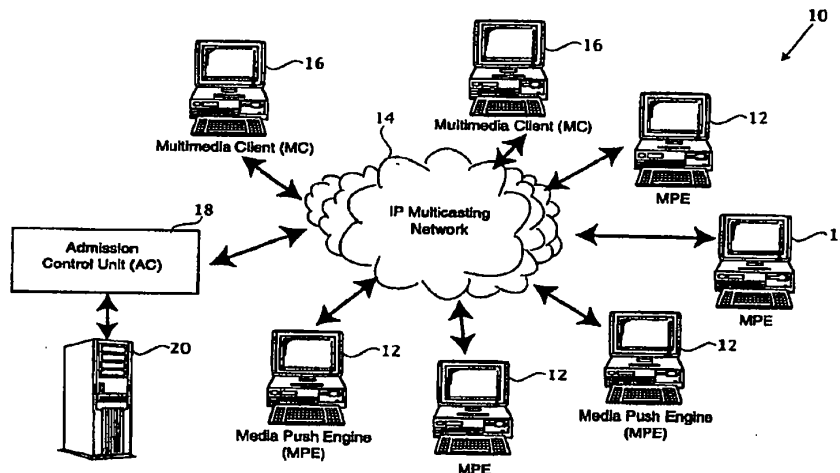

FIGURE 1

EP 0 915 598 A2

Printed by Xerox (UK) Business Services
2.16.7/3.6

Description

Background and Summary of the Invention

[0001] The present invention relates generally to networked multimedia systems. More particularly, the invention relates to a media delivery system for delivering media selections to one or more media clients over a multicasting network.

[0002] With the explosive growth of the Internet, there is a growing interest in using the Internet and other Internet protocol-based networks to deliver multimedia selections, such as video and audio material. Interactive television, movies on demand, and other multimedia push technologies are among the more promising applications.

[0003] The Internet is a connectionless network offering best effort delivery service. Packets of data are routed as datagrams that carry the address of the intended recipient. A specific connection between the sender and the recipient is not required, because all host nodes on the network include the inherent capability to route datagrams from node to node until delivery is effected. This datagram packet delivery scheme is constructed as a best effort delivery system in which the delivery of datagram packets is not guaranteed. Datagram packets may be sent via different routes in the effort to increase the likelihood of delivery. Thus, if one node on the network is experiencing congestion, subsequent datagrams may be alternately routed to avoid the congested node. This means that data datagram packets do not inherently have a guaranteed arrival time. Even packets corresponding to a single message may be received out of order. This fact significantly affects how certain multimedia data are delivered.

[0004] In many cases, multimedia data require real-time delivery. In the case of audio or video data, the data stream representing a particular media selection needs to be delivered in the proper time sequence, to allow the user to play back the audio or video selection "live" as it is being sent. Clearly, if the datagram packets are delivered out of order, due to taking different delivery routes, then playback at the multimedia client (e.g., a user's interactive TV) will be jumbled.

[0005] The Real-time Protocol (RTP) is a current *de facto* standard for delivering real-time content over the Internet (or other networks based on an IP protocol). The Real-time Protocol replaces the conventional transmission control protocol (TCP) with a framework that real-time applications can use directly for data transport. Currently, the RTP standard supports a first type of message, namely one for carrying the media content data or streaming data. Typically, a separate protocol, the Real-Time Control Protocol (RTCP) is used with RTP to pass control messages for session management, rate adaptation and the like.

[0006] While the Real-time Protocol can be used to deliver multimedia streaming data over computer net-

works, the existing architecture has not proven robust enough to provide high quality presentation using best effort network services such as those provided by the Internet. The present invention solves this problem by using a distributed media push architecture that is capable of supplying streaming data redundantly from multiple sources and over multiple distribution paths. The media push engines have associated media storage units that store streaming data as non-hierarchical sets of substream components. The components are capable of being reconstituted into a reconstructed stream from fewer than all of the components, such that the higher the number of components used in reconstitution, the higher the quality of the reconstructed stream.

[0007] Conventional systems use a hierarchical coding scheme that treats some components as more important than others. Thus, conventional systems typically need to expend considerable resources to guarantee that the more important components are always delivered. In contrast, the media delivery system of the invention uses a non-hierarchical coding scheme, multiple description coding (MDC) that treats all components as equals. Thus, no special resources need to be allocated to ensure that a given set of substream components is delivered. Naturally, the higher number of components delivered, the higher the quality achieved; on the other hand, unlike with conventional hierarchical coding, loss of any given single packet does not appreciably degrade the signal quality.

[0008] The distributed media delivery system also employs a distributed admission control system. The media client contacts a single admission control unit to request a given media selection, but thereafter the admission control decisions are handled in distributed fashion by the media push engines themselves. The admission control unit communicates the request to a plurality of media push engines distributed across the network and those push engines individually determine whether they can participate in the multicasting session. Thus, the individual media push engines each evaluate local traffic congestion to determine whether it is capable of supplying the requested data stream. The admission control unit is thus not involved in directly determining which media push engines should be admitted to a multicast group session. The admission control unit simply assigns the multicast group session address and then allows the admission process to proceed autonomously, in a distributed fashion.

[0009] For a more complete understanding of the invention, its objects and advantages, reference may be had to the following specification and to the accompanying drawings.

Brief Description of the Drawings

[0010]

Figure 1 is a network datagram illustrating a pre-

ferred embodiment of the invention;

Figure 2 is a detailed network datagram showing how two different data streams (X and Y) are distributed across the network using non-hierarchical multiple description coding;

Figure 3 is a data flow diagram illustrating one embodiment of multiple descriptive coding (MDC);

Figure 4 is a layer datagram illustrating the TCP/IP architecture and also showing how the RTP architecture may be integrated into an IP-based system;

Figure 5 is a detailed format datagram illustrating the packet format according to the Real-time Protocol (RTP);

Figure 6 is a network datagram illustrating the call admission and session management according to the invention;

Figure 7 is a detailed network datagram showing information flow between a media push engine and a multimedia client over the multicasting IP network;

Figure 8 is a network datagram illustrating the process of source component server redistribution; and

Figure 9 is a protocol datagram showing how the Real-time Protocol (RTP) may be modified to increase its reliability.

Detailed Description of the Preferred Embodiment

[0011] Referring to Figure 1, an exemplary distributed networked multimedia system is illustrated at 10. A plurality of media push engines 12 are accessible through the multicasting network 14. The presently preferred embodiment is designed to work over a network employing the Internet protocol (IP); however, the principles of the invention may be readily extended to networks using other protocols. The network 14 is also assessable by one or more multimedia clients 16, as illustrated. An admission control unit 18, accessible through network 14, performs certain admission control functions, primarily to initiate or open a multicast group session. The admission control unit includes a catalog services system 20. The catalog services system contains a database record indicating which multimedia selections are available for delivery by the plurality of media push engines. Although involved in opening a multicast group session, the admission control process is actually performed in a distributed fashion as will be more fully discussed below.

[0012] The distributed media delivery system responds to delivery requests from a multimedia client by opening a multicast group session among the media client and those multimedia push engines that have the requested media selection available for delivery. Typically multiple media push engines will participate in simultaneously delivering streaming data corresponding to the requested selection. The multimedia client is a user host that performs the presentation function. It reconstructs a final stream from the various stream

components delivered by the participating media push engines. Each media push engine has its own data storage for the stream component data and those data storage systems can be mediated by a suitable distributed file system that provides a mountable and transparent storage and retrieval function.

[0013] An important aspect of the distributed media delivery system is the manner in which streaming data are stored on the media push engines. Unlike traditional systems that store multimedia data in a hierarchical fashion, the present invention uses a non-hierarchical coding scheme, referred to here as multiple description coding (MDC). The multiple description coding splits the video and/or audio stream into substreams called components. Each component can then be coded and transmitted over the network independently from all other components. The client software on a multimedia client 16 can assemble a reconstructed stream from any subset of the components. Thus the reconstructed stream can be assembled from fewer than all of the components. The higher the number of components used in reconstruction, the higher the quality of the reconstructed stream.

[0014] Using this non-hierarchical coding to deliver streaming data over the inherently unreliable network affords surprisingly robust media delivery, particularly when multiple push engines participate in the delivery. As will be more fully discussed, the media push engines control the multicast group session admission process themselves, in a distributed fashion, adding or subtracting media push engines to the group session as needed to maintain a high quality of services. Thus, when the multicasting network 14 exhibits low traffic congestion, only a few media push engines may be needed to supply all of the components of the MDC-encoded stream. Even if some components are not delivered in a timely fashion, the multimedia client will nevertheless be able to reconstruct the stream for presentation (with some degree of degraded quality). If the network traffic congestion is high, the media push engines negotiate with one another to add additional media push engines. Because the admission control process is distributed, individual media push engines are able to assess their own local traffic congestion and will thus participate in the group session, or not, depending on local traffic conditions.

[0015] Figure 2 shows in greater detail how the multiple description coding works. In Figure 2, two multimedia streams, designated X and Y are stored across a plurality of media push engines. These streams are broken into substream components, designated by subscripts, $X_1, X_2, \dots, X_n; Y_1, Y_2, \dots, Y_n$. Note that the substream components stored across the plurality of media push engines are not necessarily the same for each engine. Thus media push engine 12a stores components X_1, X_6 and Y_1 . Similarly, media push engine 12b stores components X_2, X_7 and Y_2 .

[0016] The multimedia clients reassemble the data

stream of interest by summing the proper substream components in the proper order. Thus multimedia client 16a reconstructs stream X as illustrated, while multimedia 16b constructs stream Y as illustrated. At the multimedia client it matters not that individual substream components arrive through different paths from different media push engines.

[0017] The presently preferred multiple description coding scheme is constructed as illustrated in Figure 3. The original multimedia data stream (e.g. video and/or audio data) is decomposed into multiple subsignals and then each subsignal is independently compressed. As noted above, the decomposition is non-hierarchical, such that an acceptable signal can be recovered from any one subsignal, an incremental improvement can be realized by additional subsignals, and a perfect reconstruction is achieved when all subsignals are received exactly. Moreover, it is preferable to maximize the overall compression gain so long as the above three criteria are met.

[0018] One way to decompose the original signal is to construct each subsignal as a reduced resolution representation of the original signal. This may be done, as illustrated, by submitting the original signal through a low pass filter followed by downsampling. The subsignals thus differ only in the sampling positions. If desired, such decomposition can be obtained by a filter bank that includes the pre-filter and its shifted versions.

[0019] The pre-filter should be selected to suppress the aliasing components in the downsampled subsignals. This helps to reduce the bit rates required for coding the subsignals and to enable an acceptable image recovery from a single subsignal.

[0020] The pre-filter should further be selected so that it does not completely eliminate the high frequency components. Were the high frequency components entirely eliminated, there would be no way to recover those components in the original signal, even when all subsignals are present. Thus the filter should suppress, but not entirely eliminate, the high frequency components.

[0021] Mathematically, reconstruction of the substream components into a reconstructed stream involves inverting the matrix equation relating the samples in all the substreams and the samples in the original stream. Typically this may involve a large matrix equation, with inversion employing a large amount of computation and memory space. One way to address this computational burden is to use a block recursive reconstruction method. At each step in the recursive process a block of 2 x 2 samples in the original stream is recovered based on up to four corresponding samples in the received subcomponent streams. Of course, other computational techniques may be employed to accomplish the same result. For more information on coding and encoding in a non-hierarchical fashion using multiple description coding, see "Robust Image Coding and Transport in Wireless Networks Using a Non-Hier-

archical Decomposition," Yao Wang and Doo-man Chung. Mobile Multimedia Communications; Goodman (Plenum Press)

[0022] The MDC-coded substreams are delivered over the multicasting network as datagrams using the Real-Time Protocol (RTP) for content delivery and the Real-Time Protocol (RTCP) to implement flow control. These protocols are able to naturally coexist with the popular TCP/IP protocol used by many Internet applications. Figure 4 presents a review of these protocols through an example of how five entities might communicate with one another. In Figure 5 entities 30-38 communicate with each other using the layered architecture popularized by the Internet. It will, of course, be understood that Figure 4 is intended only to show how the presently preferred Real-Time Protocol (RTP) integrates in one possible architectural scheme. Although the Real-Time Protocol is presently preferred, this is not intended as a limitation of the invention in its broader aspects. On the contrary, other message delivery protocols may be suitably used.

[0023] In Figure 4 each of the communicating entities 30-38 has been illustrated as a layered architecture, with the physical layer at the bottom and the application layer at the top. Entity 30 communicates with entity 32 using the Ethernet Protocol at the physical level. Entity 32 and entity 34 communicate at the physical level using the ATM Protocol. In a like fashion, entity 34 communicates with entity 36 using the Ethernet Protocol, and entity 36 communicates with entity 38 using the PPP Protocol. Again, the physical layer communication protocols selected for illustration here are not intended as a limitation upon the invention as set forth in the appended claims.

[0024] Above the physical layer is the Internet Protocol (IP) layer. The IP Protocol isolates the physical or transport layer from the application layer. The IP Protocol supports connectionless communication in which packets of information are sent and received as datagrams. Note that in the illustrated example of Figure 4 all communicating entities are using the IP Protocol.

[0025] One layer above the IP Protocol two different higher level protocols have been illustrated, the TCP Protocol and the UDP Protocol. Again, the illustrations are intended only as one example of a possible configuration. The UDP Protocol or User Datagram Protocol represents a simple transport protocol. It makes no attempt to preserve the sequence of messages it delivers. The TCP Protocol or Transmission Control Protocol provides a higher level of reliability, yet insures that datagrams are delivered in the proper sequence. The TCP Protocol uses an acknowledgment system to insure that all datagrams are delivered in the proper sequence. The TCP Protocol includes a mechanism for retransmitting packets that have not been acknowledged. This acknowledgment/retransmit technique guarantees proper packet delivery, but it does not guarantee packet delivery in real-time. Thus TCP Protocol is usually

has joined the multicast group, it participates in communications using the RTCP Protocol whereby statistics of sent data and received data are exchanged among the members of the group. As noted above, the Admission Control Unit does not need to participate in these communications and hence it will remain dormant unless a request for another session is made or until the current session is requested to be terminated.

[0037] Effectively, the system implements a distributed Admission Control System, where the participating members of the group collectively and distributively make the admission control decisions. One benefit of this distributed approach is that the invention can incorporate intelligent mechanisms to prevent network congestion and to improve quality of service, despite the fact that the multicasting network is a best effort network with no guaranteed real-time delivery.

[0038] Best effort networks, particularly those lacking sophisticated traffic and user control policies, experience frequent congestions. Such congestions can result in a loss of or substantial delay of real-time data. As previously discussed, real-time data that is delivered late is effectively treated as not delivered. The continuous influx of data into a congested node of the network tends to make the congestion even worse. The present invention uses RTCP sender reports and received reports on time-sensitive transmissions as an indication that a given node may need to scale back on the number of components it is transmitting when congestion is detected.

[0039] Figure 4 illustrates how this may be accomplished. The multimedia client 16 has requested the X real-time data stream, consisting of sub-stream components X_1 , X_2 , X_3 and X_4 . Assume that Media Push Engine 12 in Figure 7 is experiencing local traffic congestion such that sub-stream components are arriving late at the multimedia client 16. The multimedia client's RTCP receiver report notifies the Media Push Engine 12 (and all other media push engines participating in the group session) that some percentage of the component data from Media Push Engine 12. Media Push Engine 12 analyzes these reports and stops sending a selected component, in this case the X_3 , thereby decreasing the amount of traffic flowing through its point of congestion. Thus, after adjustment, Media Push Engine 12 supplies only components X_1 , X_2 and X_4 to the multimedia client. As the other media push engines participating in the group session receive the same sender and receiver reports, the loss of the X_3 component from Media Push Engine 12 may be compensated for if other push engines are able to supply this missing component. Otherwise, the quality of service will be slightly degraded as discussed above.

[0040] Figure 8 illustrates how the data stream may be effectively redistributed by making local adjustments to the substream components being sent. In the illustrated example assume that there is local congestion somewhere in the data path that supplies substream compo-

nents from Media Push Engine 12b. The RTCP sender and receiver reports will thus indicate that some portion of the components previously sent to the multimedia client 16 by Media Push Engine 12b are lost or delayed due to local congestion. In the illustrated example the lost components happen also to be present in the storage system of Media Push Engine 12a. Media Push Engine 12a can either retransmit the lost component payloads to the multimedia client or simply adjust the set of components to be transmitted in future real-time data transactions. In the case where lost payloads are retransmitted by another media push engine, sufficient buffering should be supplied at the multimedia client to allow the missing components to be reassembled with the previously delivered components before the stream is reconstructed and presented to the user. In the case where the system merely alters the component set for future transmissions, such change constitutes a scalable server component redistribution mechanism. This mechanism promotes improved quality of service by improving the presentation of stream data to the multimedia client.

[0041] Although the embodiment described above is generally suitable for most media delivery applications, there are some systems that cannot tolerate even a slight degradation in quality. Such systems include high quality broadcast video distribution. In these more demanding applications, the system of the previously described preferred embodiment can be modified to employ an additional reliability mechanism for the real-time component. In this case the Real-Time Protocol may be modified or augmented to allow retransmissions of lost real-time payloads. This "Reliable RTP" is illustrated in Figure 9. The Media Push Engine communicates to the RTP stack using Real-Time Protocol. In this case assume that the first and third components are received but the second component is missing. There is an immediate negative acknowledgment (NACK) from the RTP stack, telling the Media Push Engine that the second payload was not received. The Media Push Engine then retransmits the needed payload and the RTP stack places the needed payload into the correct location within the data buffer. The client application then reads the data from the data buffer. Any duplicate packets are dropped and any excessively delayed packets may also be dropped.

[0042] From the foregoing it will be understood that the invention provides a media delivery system architecture that employs a distributed, networked technique for delivering streaming data over a best effort network. The architecture may be readily scaled, larger or smaller, as the server's complexity increases linearly with the number of clients. The architecture is thus a fully distributed, tightly coupled parallel architecture that is capable of providing simple and yet robust service.

[0043] Through the use of multiple description coding (MDC) and multiple path transport, the invention can provide a high quality of service without resorting to

delay-producing transmission retry techniques. Thus the invention will readily work with existing Real-Time Transport Protocol (RTP) for data transport and Real-Time Control Protocol (RTCP) for session management, rate adaptation and the like. When congestion is encountered the presentation can be downscaled without interruption, thanks to the multiple description coding and the manner in which participants of a group session can be added to or removed from the group. The flow control of streams is also controllable through these same mechanisms to prevent or reduce network congestion once it is detected.

[0044] The invention is therefore ideally suited for delivery of multimedia selections as well as video and audio streaming data. The invention will readily support data streams of multiple bit rates and it is capable of providing services at both constant bit rates and variable bit rates.

[0045] While the invention has been described in its presently preferred embodiments, it will be understood that the invention is capable of certain modification and change without departing from the spirit of the invention as set forth in the appended claims.

Claims

1. A distributed media delivery system for delivering media selections to a media client (16) over a multicasting network (14), characterized by:

a plurality of media push engines (12) accessible through said network (14), said push engines (12) each having associated media storage unit or storing streaming data representing the media selections available for delivery;

said media storage units being configured to store said streaming data as a non-hierarchical set of substream components capable of being reconstituted into a reconstructed stream from fewer than all of said components, such that the higher the number of components used in reconstitution, the higher quality the reconstructed stream; and

an admission control system (18, 20) accessible through said network (14), said admission control system (18, 20) including a catalog for storing the identity of the media selections available for delivery by each of said media push engines (12),

said admission control system (18, 20) being operative, in response to a request for a given media selection from a media client (16), to open a multicast group session among said media client (16) and at least a portion of said media push engines (12) having the given media selection available for delivery, whereby said media push engines participating

in said multicast group session each supply to said network those substream components corresponding to the given media selection, for delivery to and reconstitution by said media client.

2. The media delivery system of claim 1, characterized in that said admission control system (18, 20) is a distributed system defined at least in part through interaction between said media push engines (12).
3. The media delivery system of claim 1, characterized in that said media push engines (12) communicate with said network (14) over different communication paths.
4. The media delivery system of claim 1, characterized in that said network (14) is a connectionless network offering best effort delivery services.
5. The media delivery system of claim 1, characterized in that said network (14) is the Internet.
6. The media delivery system of claim 1, characterized in that said media client (16) and said media push engines (12) participating in said multicast group session employ Real-Time Transport Protocol (RTP) for data transport.
7. The media delivery system of claim 1, characterized in that said media client (16) and said media push engines (12) participating in said multicast group session employ Real-Time Control Protocol (RTCP) for session management.
8. The media delivery system of claim 1, characterized in that at least a portion of said substream components are replicated across several media push engines (12).
9. The media delivery system of claim 1, characterized in that at least a portion of said substream components are replicated across first and second media push engines (12) and that said delivery system further comprises congestion handling system for identifying one of said first and second media push engines (12) as the cause of congestion and for automatically invoking the other of said first and second media push engines (12) to participate in said multicast group session.
10. The media delivery system of claim 9, characterized by data buffering system associated with said media client (16) for storing substream components prior to reconstitution.
11. The media delivery system of claim 1, character-

ized in that said admission control unit (18, 20) is further operative, in response to a request from said media client (16) to end a multicast group session, to instruct all media push engines (12) participating in said multicast group session to terminate the session. 5

12. The media delivery system of claim 1, characterized in that said admission control system (18, 20) includes an admission control unit (18) that maintains a pool of multicast session addresses for use in invoking multicast group sessions and wherein said admission control unit (18) assigns a designated multicast session address, selected from said pool, for use by said multicast group session. 10 15
13. The media delivery system of claim 12, characterized in that said admission control unit (18) is further operative, in response to a request from said media client (16) to end a multicast group session, to return said designated multicast session address to said pool. 20
14. The media delivery system of claim 12, characterized in that said media client (16) and said media push engines (12) participate in said multicast group session exchange flow control messages without involving said admission control unit (18). 25
15. The media delivery system of claim 1, characterized in that between said media client (16) and every media push engine (12) participating in said multicast group session there is a unicast flow of datagrams containing real-time stream component data. 30 35

40

45

50

55

8

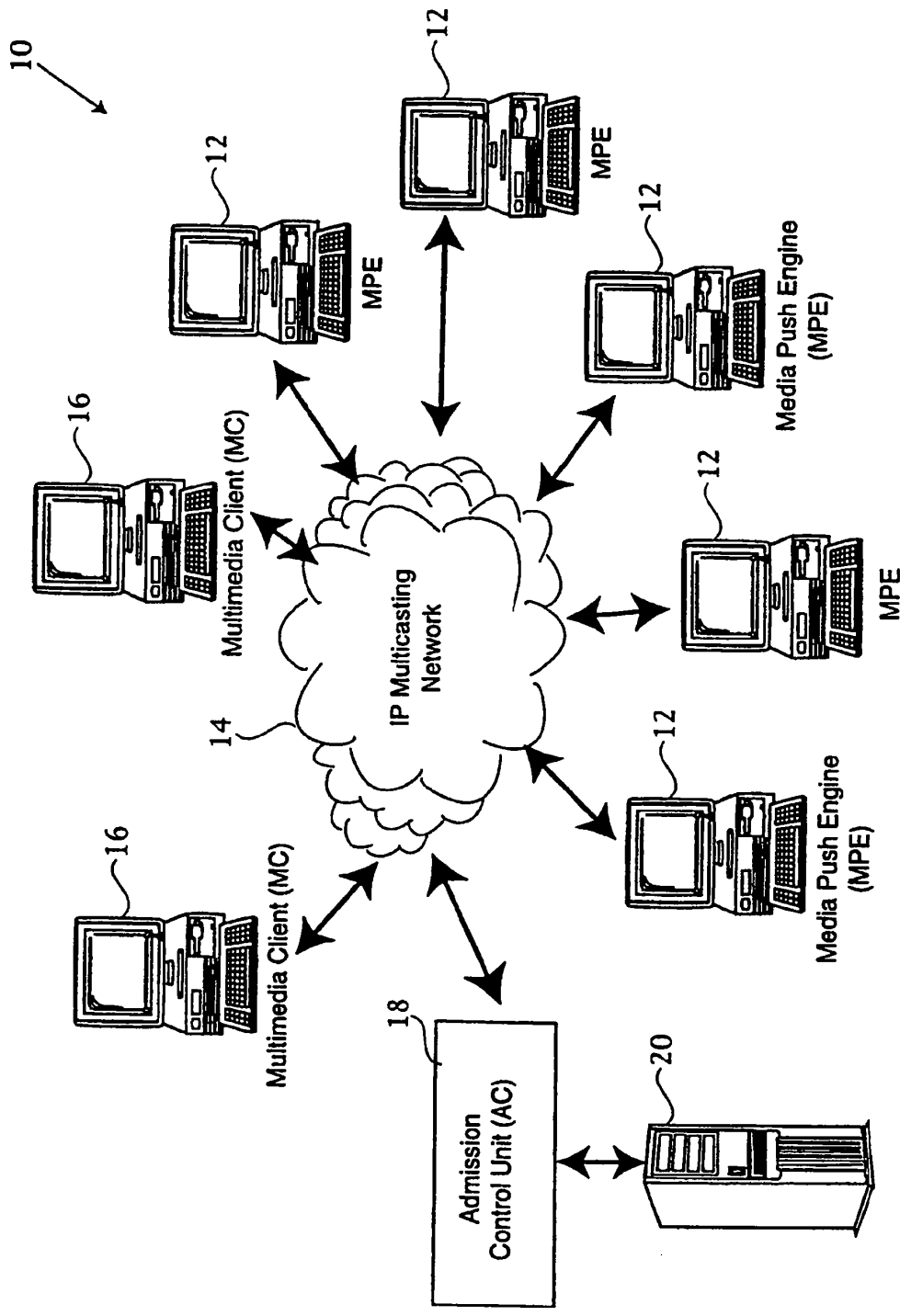

FIGURE 1

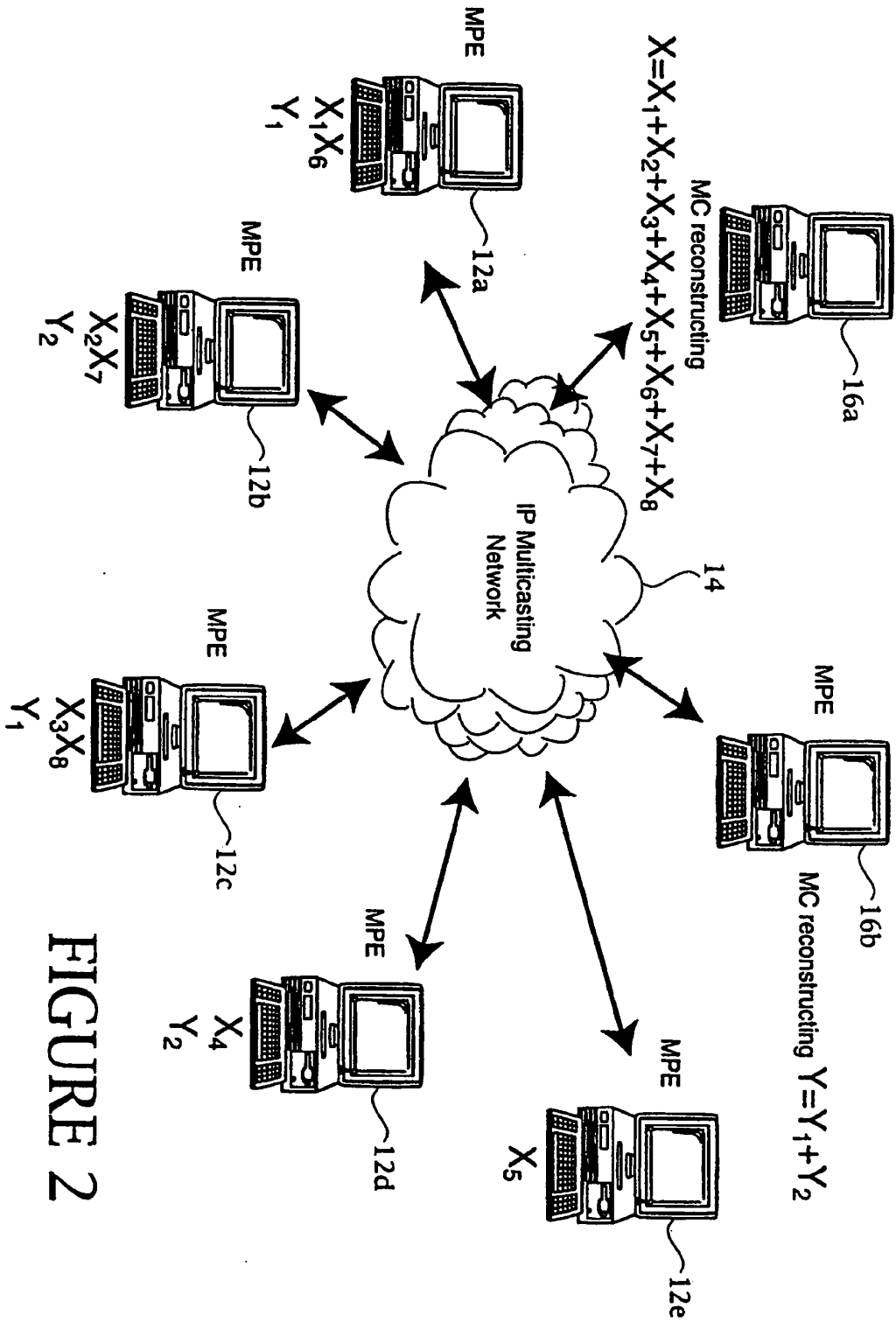

FIGURE 2

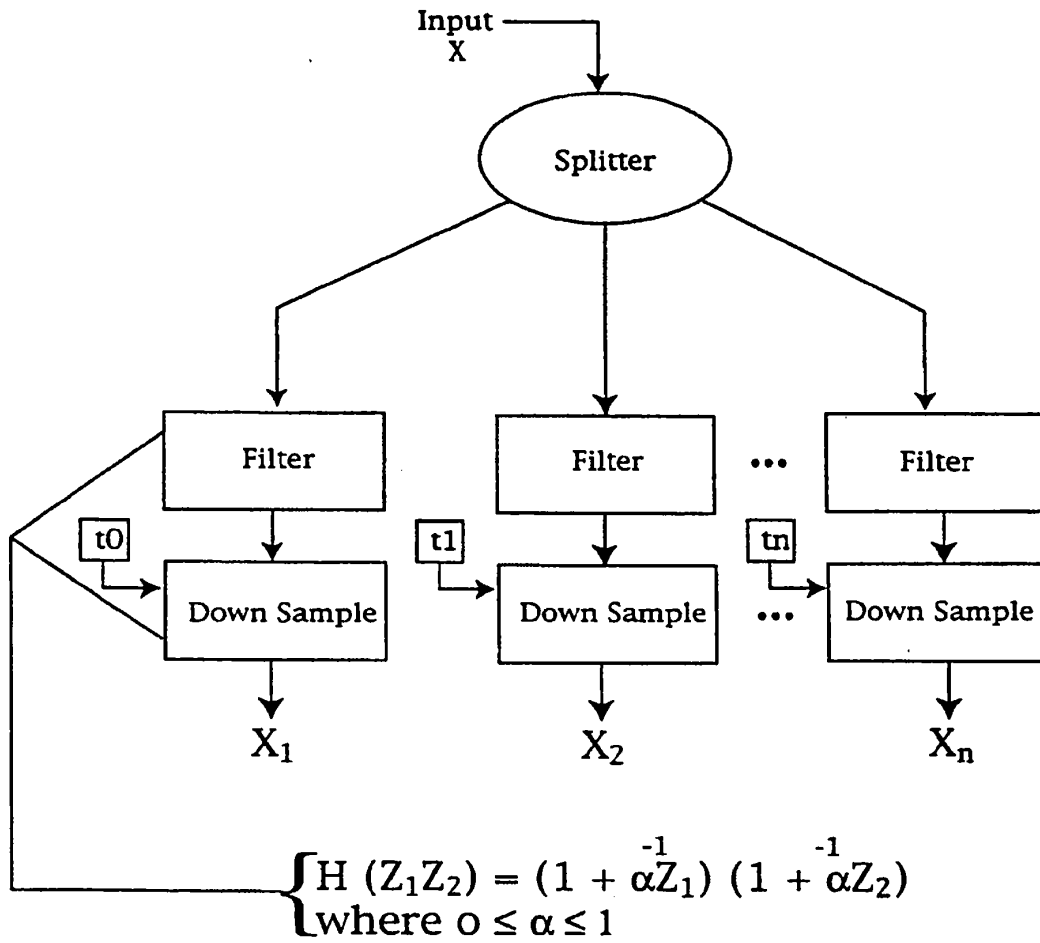

FIGURE 3

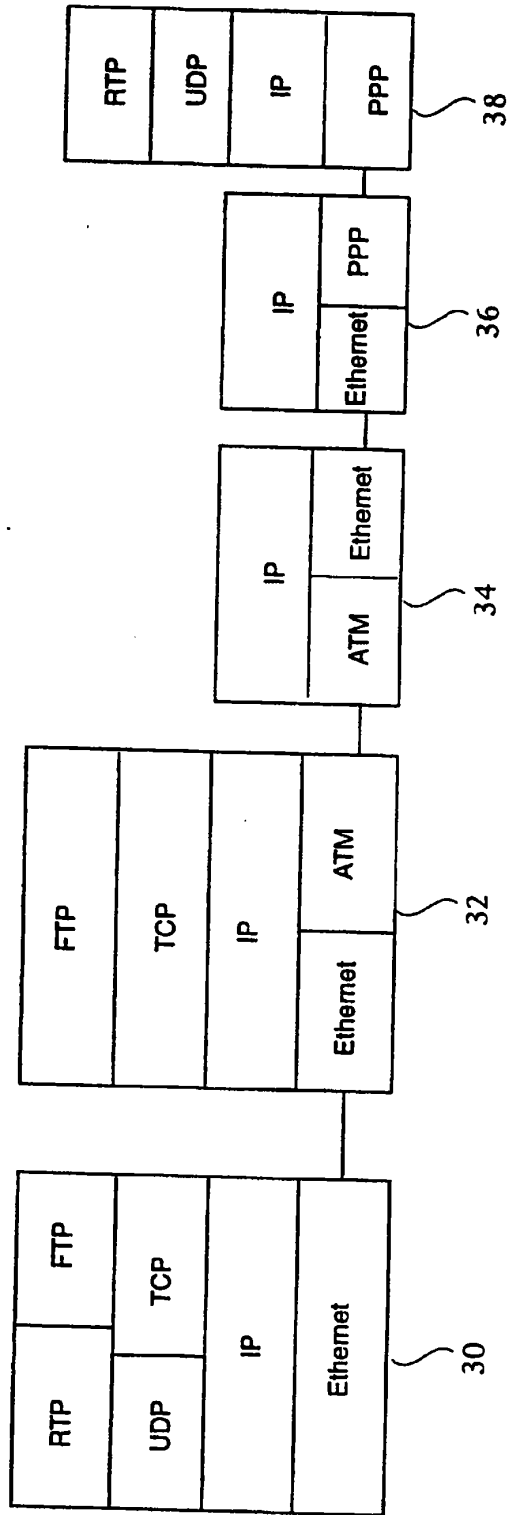

FIGURE 4

RTP Packet Format

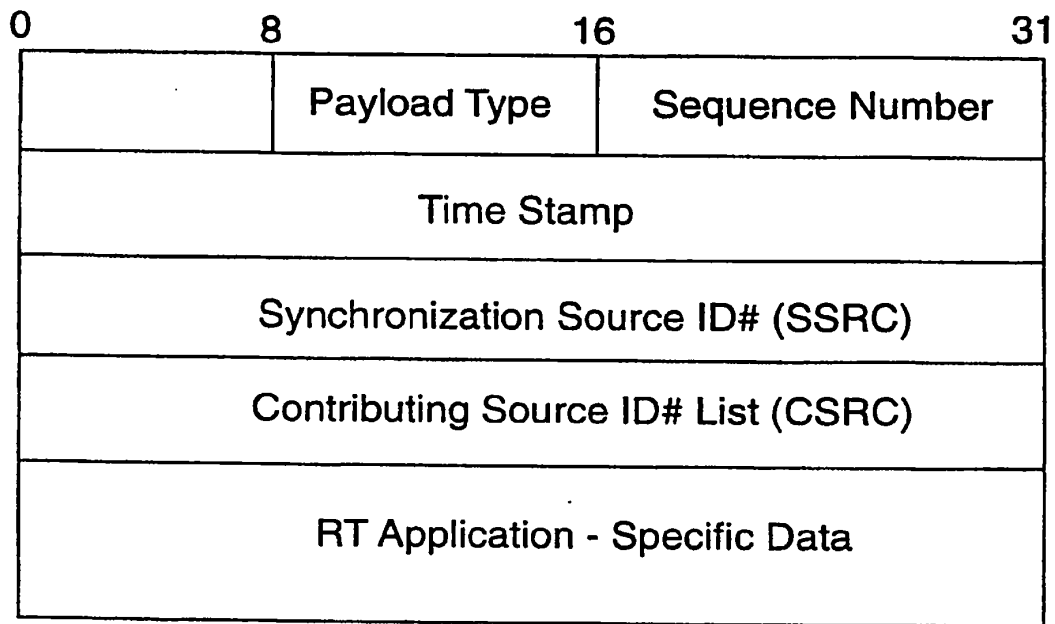

FIGURE 5

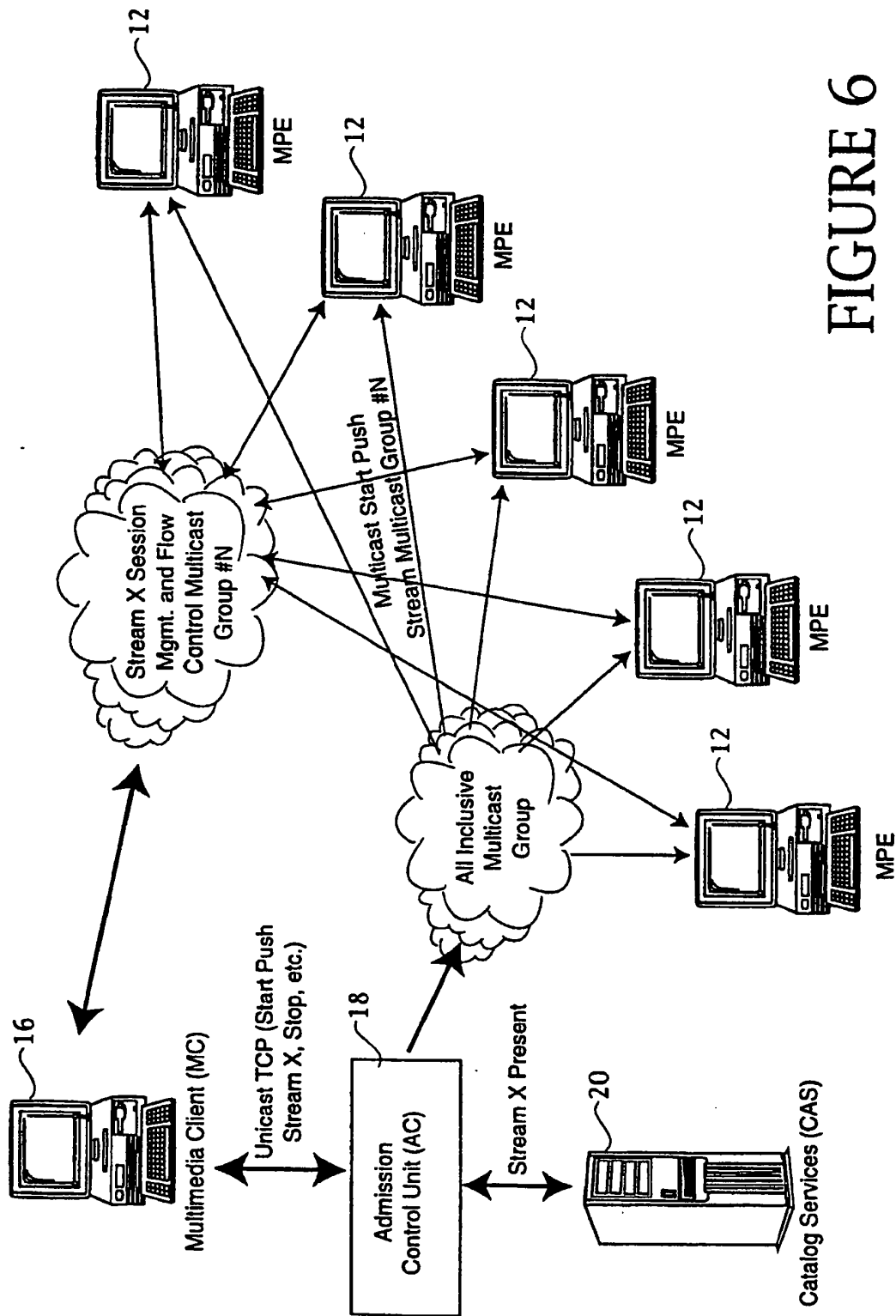

FIGURE 6

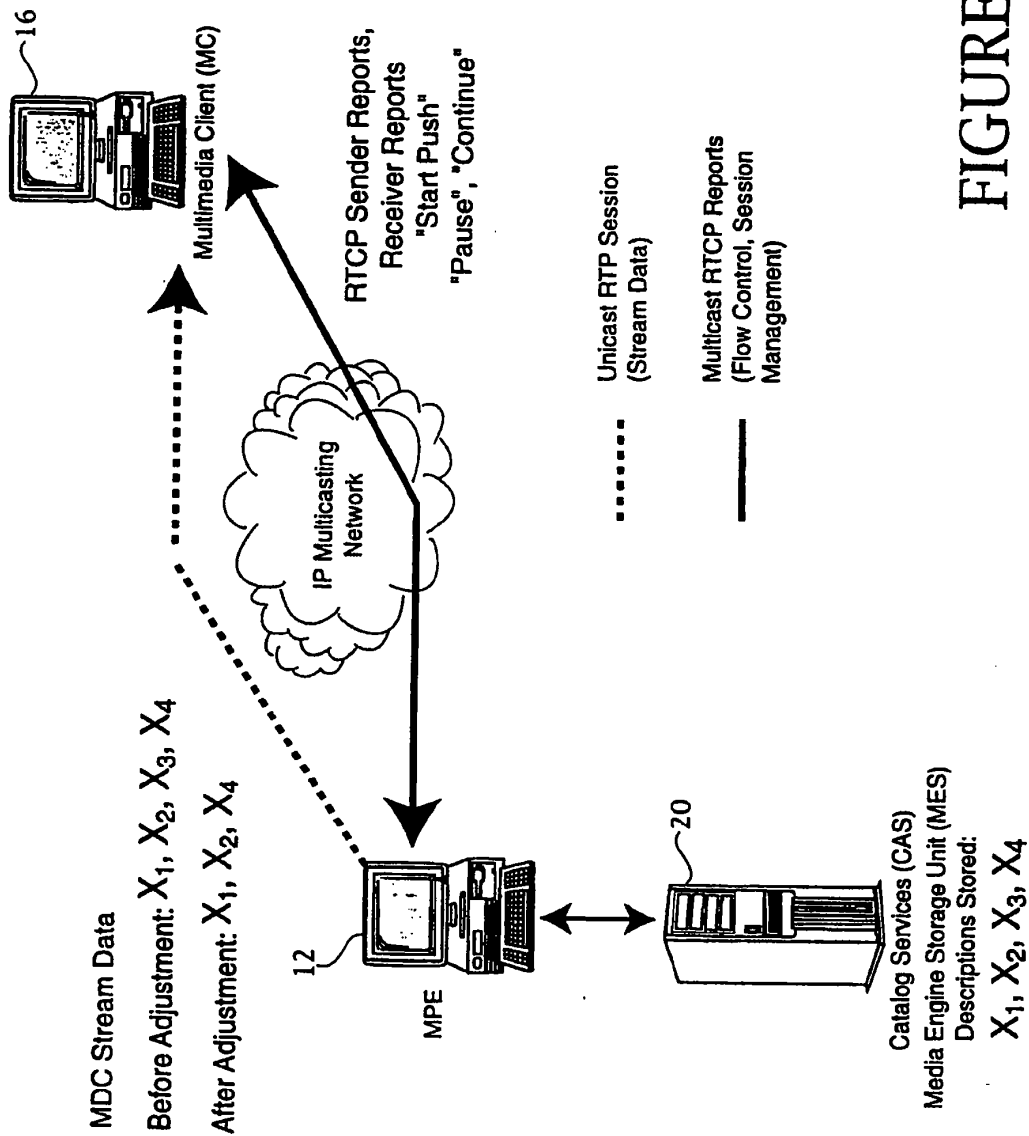

FIGURE 7

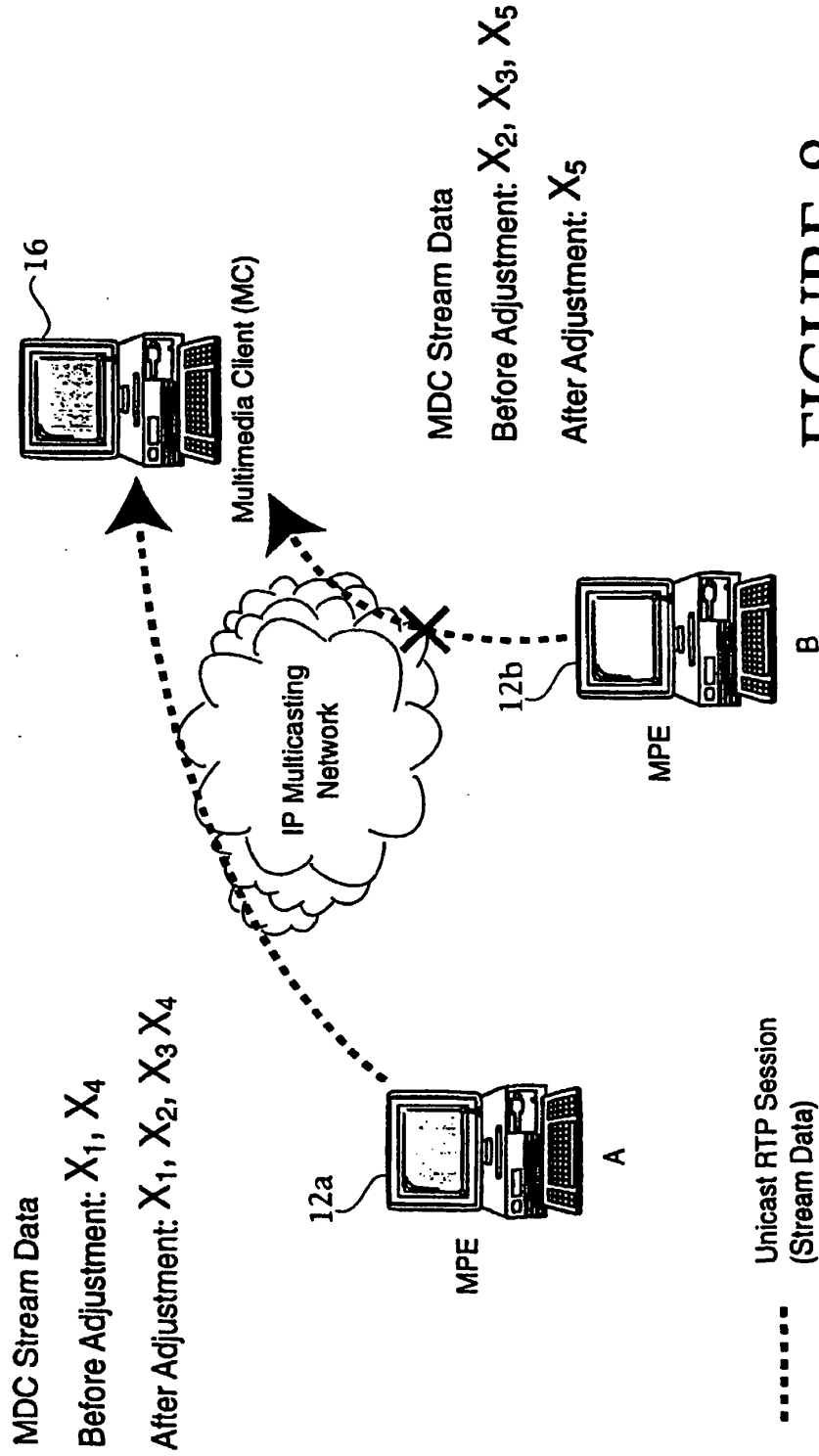

FIGURE 8

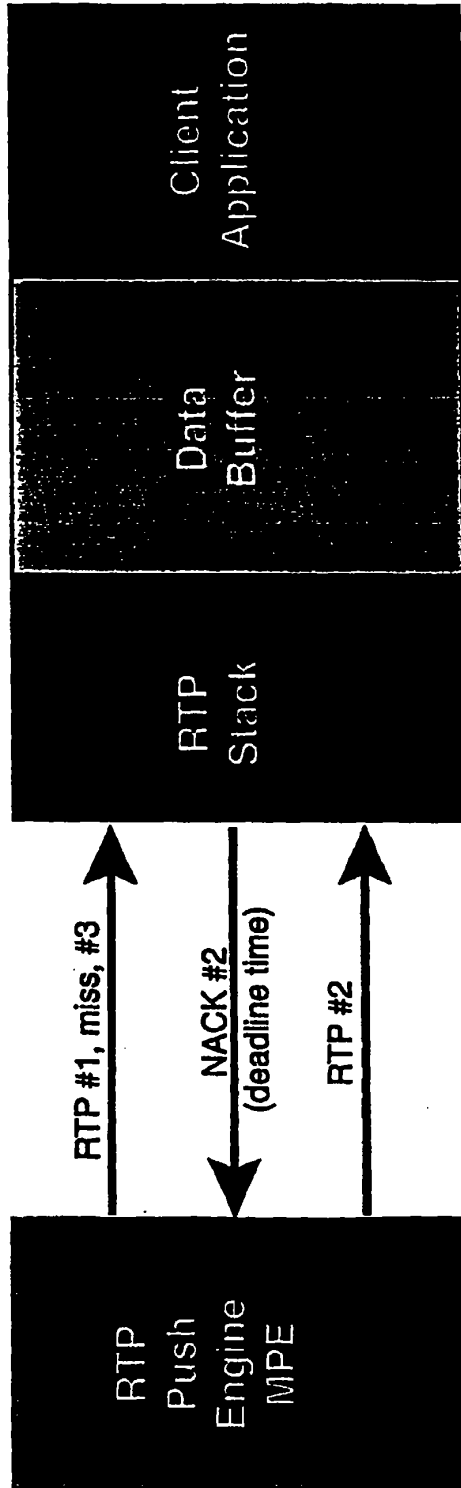

FIGURE 9



(12) **EUROPEAN PATENT APPLICATION**

(43) Date of publication:
30.08.2000 Bulletin 2000/35

(51) Int Cl.7: **H04H 7/00**

(21) Application number: **99308057.1**

(22) Date of filing: **13.10.1999**

(84) Designated Contracting States:
AT BE CH CY DE DK ES FI FR GB GR IE IT LI LU
MC NL PT SE
 Designated Extension States:
AL LT LV MK RO SI

(72) Inventor: **Chatfield, Robert Jeffries**
357853 Singapore (SG)

(30) Priority: **15.02.1999 SG 9900051**

(74) Representative: **Powell, Timothy John**
Eric Potter Clarkson,
Park View House,
58 The Ropewalk
Nottingham NG1 5DD (GB)

(71) Applicant: **Advent Television Ltd.**
Singapore 298135 (SG)

(54) **A system for electronic placement and broadcast of an advertisement**

(57) A system for placing advertisements and broadcast thereof is disclosed, comprising:

a data server, accessible via a plurality of networked computers, for receiving data concerning an advertisement and arranged to validate said data and communicate validated data to at least one processor means;

each processor means being associated with a corresponding media broadcast system and arranged to allocate each advertisement represented by validated data at least one broadcast time and communicate said validated data to layout generation means at each broadcast time;

said layout generation means responsive to the validated data to produce an advertisement display and to combine the advertisement display with a media display for broadcast by the media broadcast system.

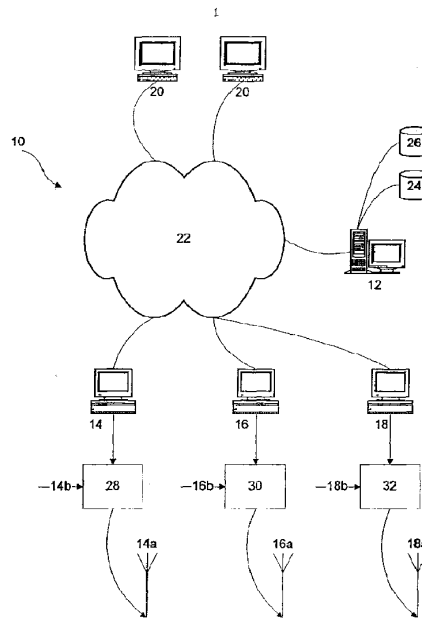

FIGURE 1

DescriptionFIELD OF THE INVENTION

[0001] This invention relates to a system for electronic placement and broadcast of an advertisement. The invention is particularly, although not exclusively, suited for broadcasting advertisements by television.

BACKGROUND ART

[0002] Currently, advertisements can be placed in a number of different media types, including newspapers and television.

[0003] The cost of placing an advertisement in a newspaper is relatively low. However, newspaper classifieds tend to be visually unattractive, typically consisting of large volumes of text. Adding graphic material to a newspaper classified advertisement can significantly increase the cost of the advertisement.

[0004] Television advertisements have a relatively high cost for both production and broadcast. As such, television advertisements are generally not suited to smaller, individual advertisements.

[0005] Television advertisements have the advantage of reaching a group of people who may be watching a single television. Further, television advertisements tend to be more dynamic than printed text and are therefore more likely to catch the attention of a casual observer.

DISCLOSURE OF THE INVENTION

[0006] Throughout the specification, unless the context requires otherwise, the word "comprise" or variations such as "comprises" or "comprising", will be understood to imply the inclusion of a stated integer or group of integers but not the exclusion of any other integer or group of integers.

[0007] In accordance with a first aspect of this invention, there is provided a system for placing advertisements and broadcast thereof, comprising:

a data server, accessible via a plurality of networked computers, for receiving data concerning an advertisement and arranged to validate said data and communicate validated data to at least one processor means;

each processor means being associated with a corresponding media broadcast system and arranged to allocate each advertisement represented by validated data at least one broadcast time and communicate said validated data to layout generation means at each broadcast time;

said layout generation means responsive to the validated data to produce an advertisement display

and to combine the advertisement display with a media display for broadcast by the media broadcast system.

5 [0008] Preferably, the data server includes a clip art gallery from which advertisers can select clip art.

[0009] Preferably, said data includes:

10 a text description;
payment information;
selected clip art;
coverage data; and
advertising frequency data.

15 [0010] Preferably, said data server includes filter means arranged to remove predetermined words from said text description.

20 [0011] Preferably, said filter means performs a search of the text description for any word or phrase in a list of prohibited words and phrases.

[0012] In one arrangement, said filter means is arranged to reject said advertisement if the text description contains more than a predetermined number of prohibited words or phrases.

25 [0013] Preferably, said data server includes financial verification means arranged to confirm said payment information is valid.

[0014] Preferably, said financial verification means calculates the cost of said advertisement from at least said coverage data and said advertising frequency data.

30 [0015] Preferably, said financial verification means obtains payment for the calculated cost before verifying said data.

[0016] Preferably, said data server is arranged to communicate said validated data to at least one processor means whose media broadcast system operates in said coverage area.

[0017] Preferably, said data server includes a store of advertisements accessible via the plurality of networked computers.

40 [0018] Preferably, said data server is arranged to add an advertisement corresponding to validated data to said store.

[0019] Preferably, said media broadcast system comprises a television broadcast station.

[0020] Preferably, said television broadcast station comprises a digital television broadcast station.

[0021] Preferably, said media display comprises a television picture.

50 [0022] Preferably, said media display and the advertisement display occupy separate regions on the television.

[0023] Alternatively, the advertisement display is superimposed on the media display.

55

BRIEF DESCRIPTION OF THE DRAWINGS

[0024] The invention will now be described with refer-

ence to one embodiment thereof and the accompanying drawing, which shows the system of the embodiment.

BEST MODE(S) FOR CARRYING OUT THE INVENTION

[0025] The embodiment is directed towards a system 10 for placing advertisements and broadcast thereof. The system 10 comprises a data server in the form of a first computer 12, and three processor means in the form of second computers 14, 16 and 18. Each of the second computers 14, 16 and 18 are associated with a corresponding digital television broadcast system 14a, 16a and 18a.

[0026] The first computer 12 is accessible via plurality of networked computers 20. The first computer 12 and the computers 20 are internetworked by any suitable means, such as a MAN, WAN, or the Internet. The network is shown in the diagram as 22.

[0027] The first computer 12 includes an advertisement placement facility accessible from any of the computers 20. It is envisaged that the advertisement placement facility will be a web page on the Internet in some embodiments.

[0028] A user accessing the advertisement placement facility on the first computer 12 can enter data concerning their advertisement. By submitting their data, the user is requesting that the advertisement is broadcast. This data includes:

- a text description. This forms the basis of the advertisement.
- payment information in the form of a credit card number, expiry date and type.
- clip art selected by the user. The first computer 12 includes a first store 24 of clip art from which the user can choose.
- coverage data selected from a list. The list details the areas that the advertisement can be broadcast to, determined by the coverage area of the digital television broadcast systems 14a, 16a and 18a. The user selects one or more areas from the list according to his or her requirements.
- advertising frequency data, including dates. This data is entered by the user. It is preferred that the advertising frequency data other than the dates are chosen from a list. In this manner, predetermined costs can be ascribed to each item in the list. Examples include the advertisement being broadcast at least four times each day for \$15 per area, or broadcast once per hour for \$40 per area. It is envisaged that a variety of ways of presenting the information to the user can be adopted. It is also envisaged that the user may be able to specify time

slots during which their advertisement will be broadcast.

- email address. This is not essential, however it allows the system 10 to provide the user with feedback concerning their advertisement.

[0029] The first computer 12 then validates the data as follows. Firstly, the text description is passed through a filter to remove any prohibited words or phrases. This is to ensure that undesirable material is not broadcast. The filter can take several forms, including a literal comparison of each word in the text description with a list of prohibited words and a phonetic comparison.

[0030] If the text description contains more than a predetermined number of prohibited words, the advertisement is rejected. If the user supplied an email address, the user is sent a message informing them of the rejection.

[0031] If the message is not rejected, the first computer 12 then calculates the cost of the advertisement from the submitted data. The cost can be based data such as the coverage area, advertisement frequency data, and whether any clip art is selected.

[0032] The first computer 12 then validates the payment information. Preferably, this is done by the first computer 12 effecting payment of the calculated cost from the credit card. If the payment is refused, the advertisement is rejected and the user is sent an appropriate message.

[0033] If the text description and the payment information are successfully validated, the first computer forms validated data comprising the filtered text description, clip art selected by the user, coverage data, advertising frequency data, and email address. The validated data is then communicated to the relevant second computer 14, 16 and/or 18 based on the coverage data. For convenience, the second computers 14, 16 and 18 are also connected to the network 22. In other embodiments, the second computers 14, 16 and 18 may be in communication with the first computer 12 by other means.

[0034] The first computer 12 also includes a second store 26 which contains advertisements that are successfully validated. The advertisements in the second store 26 are accessible from the computers 20 via the Internet 22. Preferably, a search facility is provided for users to access the second store 26.

[0035] Each of the second computers 14, 16 and 18 receives validated data from the first computer 12 for advertisements whose coverage data corresponds with the coverage area of the corresponding digital television broadcast systems 14a, 16a and 18a.

[0036] Each of the second computers 14, 16 and 18 processes the received validated data in the same manner. The following description will be made with reference to the second computer 14, however it is also applicable to the second computers 16 and 18.

[0037] When the second computer 14 receives validated data from the first computer 12, the validated data is processed as follows.

[0038] The second computer 14 analyses the advertisement frequency data to determine the number of times the advertisement will be broadcast, the dates of the broadcast, etc. The second computer 14 then reads the advertisement frequency data of all other validated data it has received concerning the dates and times the current validated data.

[0039] The second computer 14 then schedules the advertisements and allocates particular broadcast times to each advertisement. These broadcast times are stored along with the validated data for each advertisement on the second computer 14. If the second computer 14 determines that a particular time interval is full, it communicates with the first computer 12, which then prevents further users from selecting a full time interval.

[0040] When the broadcast time of an advertisement is reached, the second computer 14 communicates the validated data to a layout generation device 28. If an email address was specified by the user, the second computer 14 sends the user a message confirming when the advertisement was broadcast. The second computers 16 and 18 communicate with layout generation devices 30 and 32, respectively.

[0041] The layout generation device 28 receives validated data from the second computer 14 and a digital TV picture for transmission by the digital television broadcast station 14a, shown in the diagram at 14b. Similarly, digital TV pictures for transmission by the digital television broadcast stations 16a and 18a are shown in the diagram at 16b and 18b, respectively.

[0042] The layout generation device 28 generates an advertisement display from the validated data. The advertisement display is then combined with the digital TV picture 14b. The combined display is sent to the digital TV broadcast station 14a to be broadcast. Preferably, the advertisement display occupies a separate portion of the total display to the digital TV picture, for instance the lower $\frac{1}{4}$ of the total display.

[0043] The layout generation device 28 creates the advertisement display from the text description and the selected clip art in the validated data. It is envisaged that display options could be provided, whereby the user can select a fade-in and fade-out, foreground and background colours, fonts, scrolling and scrolling speed, etc which would form part of the validated data. The layout generation device 28 would then generate the advertisement display using the display options. Note that the advertisement display is not necessarily a static display, hence the layout generation device 28 generates an advertisement display for each frame of digital TV picture.

[0044] It is envisaged that in some embodiments, the layout generation device 28 may be integrated with the second computer 14. This is particularly advantageous when dealing with digital TV pictures.

[0045] It should be appreciated that the invention is

not limited to the particular embodiment described above.

5 Claims

1. A system for placing advertisements and broadcast thereof, comprising:

10 a data server, accessible via a plurality of networked computers, for receiving data concerning an advertisement and arranged to validate said data and communicate validated data to at least one processor means;

15 each processor means being associated with a corresponding media broadcast system and arranged to allocate each advertisement represented by validated data at least one broadcast time and communicate said validated data to layout generation means at each broadcast time;

20 said layout generation means responsive to the validated data to produce an advertisement display and to combine the advertisement display with a media display for broadcast by the media broadcast system.

25 2. The system of claim 1, wherein the data server includes a clip art gallery from which advertisers can select clip art.

30 3. The system of claim 1 or 2, wherein said data includes:

35 a text description;
payment information;
selected clip art;
40 coverage data; and
advertising frequency data.

45 4. The system of any one of the preceding claims, wherein said data server includes filter means arranged to remove predetermined words from said text description.

50 5. The system of claim 4, wherein said filter means performs a search of the text description for any word or phrase in a list of prohibited words and phrases.

55 6. The system of claim 5, wherein said filter means is arranged to reject said advertisement if the text description contains more than a predetermined number of prohibited words or phrases.

7. The system of any one of the preceding claims,

- wherein said data server includes financial verification means arranged to confirm said payment information is valid.
8. The system of claim 7, wherein said financial verification means calculates the cost of said advertisement from at least said coverage data and said advertising frequency data. 5
9. The system of claim 8, wherein said financial verification means obtains payment for the calculated cost before verifying said data. 10
10. The system of any one of the preceding claims, wherein said data server is arranged to communicate said validated data to at least one processor means whose media broadcast system operates in said coverage area. 15
11. The system of any one of the preceding claims, wherein said data server includes a store of advertisements accessible via the plurality of networked computers. 20
12. The system of claim 11, wherein said data server is arranged to add an advertisement corresponding to validated data to said store. 25
13. The system of any one of the preceding claims, wherein said media broadcast system comprises a television broadcast station. 30
14. The system of claim 13, wherein said television broadcast station comprises a digital television broadcast station. 35
15. The system of Claim 13 or 14, wherein said media display comprises a television picture.
16. The system of Claim 15, wherein said media display and the advertisement display occupy separate regions on the television. 40
17. The system of Claim 15, wherein the advertisement display is superimposed on the media display. 45
18. A method for placing advertisements and broadcasts thereof, the method comprising:
- receiving, at a data server accessible via a plurality of networked computers, data concerning an advertisement; 50
 validating said data;
 communicating validated data to at least one processor means, each processor means being associated with a corresponding media broadcast system; 55
 allocating to each advertisement, represented
- by validated data, at least one broadcast time;
 communicating said validated data to layout generation means at each broadcast time;
 said layout generation means producing an advertisement display responsive to the validated data and combining the advertisement display with a media display for broadcast by the media broadcast system.
19. A computer program product directly loadable into the internal memory of a digital computer, comprising software code portions for performing the method of Claim 18 when said product is run on a computer.
20. Electronic distribution of a computer program according to Claim 19.

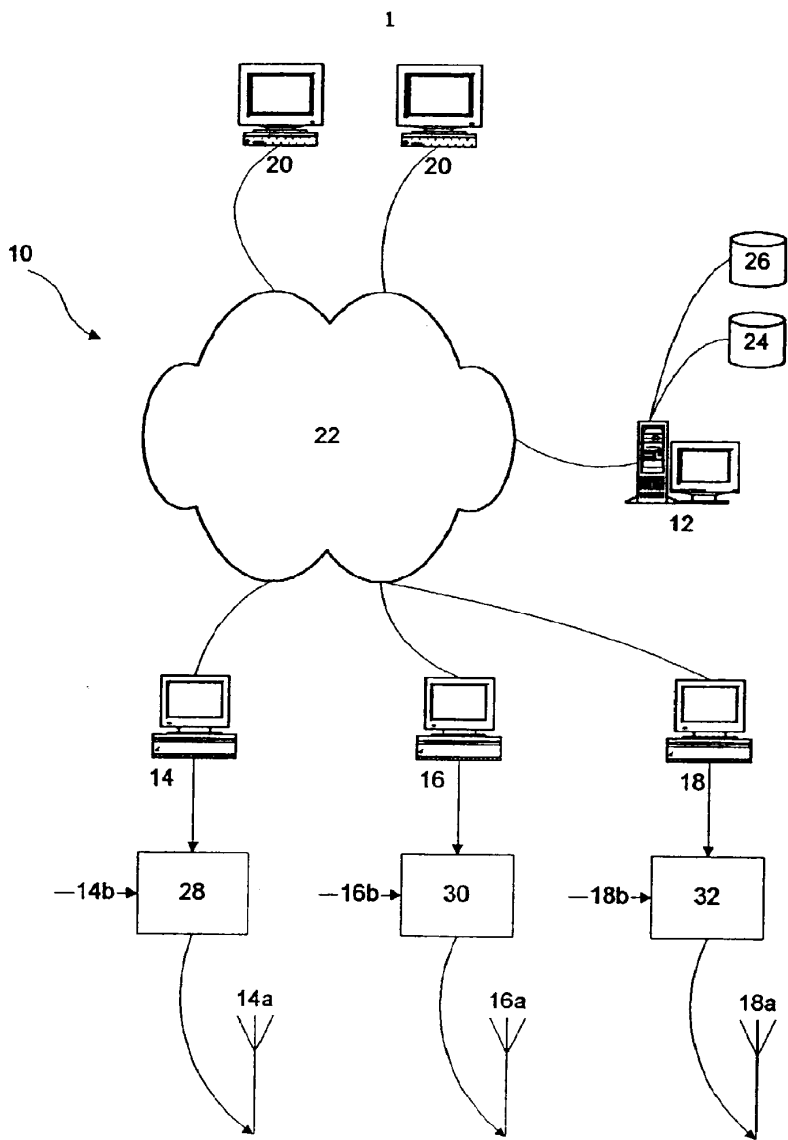

FIGURE 1



(12) **EUROPEAN PATENT APPLICATION**

(43) Date of publication:
 24.01.2001 Bulletin 2001/04

(51) Int Cl.7: **H04Q 7/22**

(21) Application number: **99401864.6**

(22) Date of filing: **22.07.1999**

(84) Designated Contracting States:
AT BE CH CY DE DK ES FI FR GB GR IE IT LI LU MC NL PT SE
 Designated Extension States:
AL LT LV MK RO SI

- **Ramalho, Maria Fernanda**
 1170 Brussels (BE)
- **Sales, Bernard**
 1190 Brussels (BE)
- **Aerts, Helena Tine**
 2000 Antwerp (BE)

(71) Applicant: **ALCATEL**
 75008 Paris (FR)

(74) Representative: **Plas, Axel**
Alcatel Bell N.V.
Francis Wellesplein 1
2018 Antwerpen (BE)

(72) Inventors:
 • **Leroy, Suresh André Jean-Marie**
 2970 Schilde (BE)

(54) **Method to multi-cast data packets to mobile stations, and related gateway, service and routing nodes**

(57) To transfer public data packets (PU-DP) from an originating terminal (TE) to a plurality of mobile stations (MS1, MS2, MS3, MS4, MS6) over a public data packet network (INTERNET) and a mobile data packet network (GPRS-SYSTEM), the public data packets (PU-DP) are multi-casted through the public data packet network (INTERNET) by means of a multi-cast address

(PU-MCA) in an overhead section (PU-H) of the public data packets (PU-DP). In addition, the public data packets (PU-DP) are multi-casted through at least part of the mobile data packet network (GPRS-SYSTEM) by means of a private multi-cast address (PR-MCA) in an overhead section (PR-H) of private data packets (PR-DP) that tunnel the public data packets (PU-DP) through the mobile data packet network (GPRS-SYSTEM).

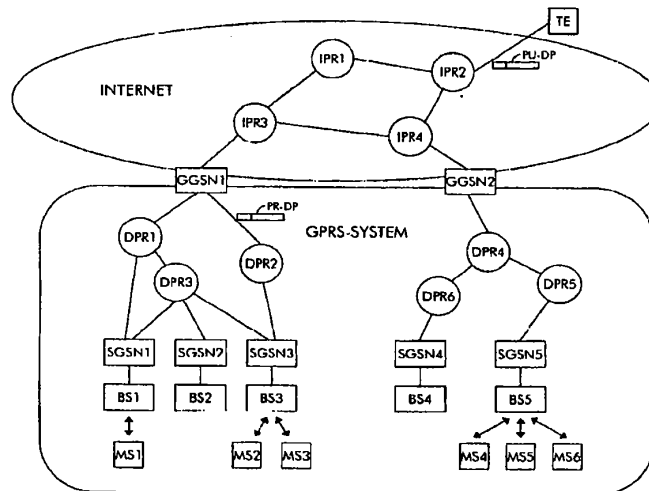

Fig. 1

Description

[0001] The present invention relates to a method to transfer data packets over a public data packet network and a mobile data packet network to a plurality of mobile stations as defined in the non-characteristic part of claim 1, a gateway node for interfacing between the public data packet network and the mobile data packet network as defined in the non-characteristic part of claim 2, a service node for serving mobile stations in the mobile data packet network as defined in the non-characteristic part of claim 6, and a routing node for routing data packets in between gateway nodes and service nodes of the mobile data packet network as defined in the non-characteristic part of claim 9.

[0002] Such a method for transferring data packets through a mobile data packet network, as well as a gateway node, service node and routing node of the mobile data packet network are already known in the art, e.g. from the standard specification "Digital Cellular Telecommunications System (Phase 2+); General Packet Radio Service (GPRS); Service Description; Stage 2", published by ETSI (European Telecommunications Standards Institute) under the reference TS/SMG-030360Q. This standard specification is also named "GSM 03.60 Version 6.0.0" but will be referred to by "GPRS Specification" in the remainder of this patent application. The GPRS Specification describes a data packet service for a mobile communication network that makes use of the GSM (Global System for Mobile Communications) air interface for the communication between base stations and mobile stations. For the communication up to the base stations, the GPRS Specification introduces two new network nodes: a Gateway GPRS Support Node (GGSN) provides inter-working between an external or public packet switching network and the mobile or private packet switching network, whereas a Serving GPRS Support Node (SGSN) keeps track of the individual mobile stations within a certain service area, and performs security functions, access control and mobility functions, e.g. change of SGSN by a mobile station. The architecture of a GPRS (General Packet Radio Service) system built up of Gateway GPRS Support Nodes, Serving GPRS Support Nodes, Base Stations and Mobile Stations is illustrated by Figure 2 and Figure 3 respectively on page 18 and 19 of the above cited GPRS Specification. Figure 4 on page 21 gives an overview of the protocol stack used for transferring data packets through the GPRS system. To route data packets received from an external data packet network like the internet to a mobile station in the known GPRS system, a so called point-to-point tunnel is set up from the Gateway GPRS Support Node (GGSN) that receives the data packets from the external data packet network to the Serving GPRS Support Node (SGSN) in whose service area the mobile station is residing. This means that the external data packets are encapsulated in internal data packets in the Gateway

GPRS Support Node, that these internal data packets are routed to the Serving GPRS Support Node accordance with an internal routing protocol, and that the external data packets are de-capsulated from the internal data packets in the Serving GPRS Support Node to be forwarded to the Base Station that will send the data packets to the mobile station over the air interface.

[0003] If in the known GPRS system the same data packets have to be transferred to more than one mobile station residing in the same service area, for instance because these mobile stations are members of the same multicast group in the external network, these data packets will independently be forwarded from the Gateway GPRS Support Node (GGSN) to the different mobile stations via separate point-to-point tunnels. In such situations, network resources are inefficiently used in the known mobile data packet network because duplicated data packets are transferred over the common part of the routes to the different mobile terminals.

[0004] An object of the present invention is to provide a method for transferring data packets through a mobile data packet network, as well as a gateway node, a service node and a routing node similar to the above known ones, but which use network resources, i.e. bandwidth capacity, more efficiently in case the same data packets have to be routed to a plurality of mobile terminals.

[0005] According to the invention, this object is achieved by the method to transfer data packets over a public data packet network and a mobile data packet network to a plurality of mobile stations as defined in claim 1, the gateway node for interfacing between the public data packet network and the mobile data packet network as defined in claim 2, the service node for serving mobile stations in the mobile data packet network as defined in claim 6, and the routing node for routing data packets in between gateway nodes and service nodes of the mobile data packet network as defined in claim 9.

[0006] Indeed, by multi-casting the internal data packets (named private data packets in the remainder of this patent application because they are routed within the mobile data packet network that is usually owned by a private operator) that tunnel external data packets (named public data packets in the remainder of this patent application because they are routed through a public data packet network such as the internet) that belong to an external multi-cast connection, it is avoided that the same public data packets are duplicated and encapsulated in different private data packets that are transferred over at least partially common routes in the mobile data packet network. Multi-casting internal data packets is realised via internal multi-cast addresses associated with external multi-cast groups where a mobile station can subscribe to. When a gateway node receives public data packets for a multi-cast connection, it will send these data packets on the private multi-cast tree which contains service nodes that contain members of the external multi-cast group in their service area. The service nodes further send the data packets to the mo-

mobile stations that are member of the multi-cast group via point-to-point connections. In this way, the network resources for transfer of data between the gateway nodes and the service nodes are used more efficiently and the capacity of the mobile data packet network is enlarged significantly in particular if the share of multi-cast traffic in the aggregate data traffic is significant.

[0007] It is to be noticed that the term 'comprising', used in the claims, should not be interpreted as being limitative to the means listed thereafter. Thus, the scope of the expression 'a device comprising means A and B' should not be limited to devices consisting only of components A and B. It means that with respect to the present invention, the only relevant components of the device are A and B.

[0008] Similarly, it is to be noticed that the term 'coupled', also used in the claims, should not be interpreted as being limitative to direct connections only. Thus, the scope of the expression 'a device A coupled to a device B' should not be limited to devices or systems wherein an output of device A is directly connected to an input of device B. It means that there exists a path between an output of A and an input of B which may be a path including other devices or means.

[0009] An additional feature of the gateway node according to the present invention is defined by claim 3.

[0010] This, a mobile station can become member of a public multi-cast group by transmitting a public join message towards a gateway node. The gateway node can interpret this public join message and inform the service node in whose service area the mobile station is residing, that the mobile station becomes member of the public multi-cast group via a private join message. The private join message is addressed to the service node and contains the public join message received by the gateway node. It is necessary to first transfer the public join message to the gateway node and to feed back the public join message encapsulated in a private message to the service node because the service node cannot interpret the public join message transmitted by the mobile station towards the gateway node.

[0011] An alternative way of joining the public multi-cast group requires that the mobile station sends a GPRS specific join message that can be interpreted by both the service node and the gateway node. This alternative does not require feedback of join messages from the gateway node to the service node but involves modification of the GPRS standard specification because the format of such a GPRS specific join message has to be standardised.

[0012] Another feature of the gateway node according to the present invention is defined in claim 4.

[0013] In this way, by assigning to the private multi-cast group that is associated with a public multi-cast group a private multi-cast address that is equal to the public multi-cast address, complexity of the address association means in the gateway node is minimised. No table linking the private multi-cast addresses with the

public multi-cast addresses has to be maintained in gateway nodes and service nodes.

[0014] Compared to claim 4, an alternative implementation of the gateway node according to the present invention is defined by claim 5.

[0015] In this way, the address association means in the gateway node needs to keep track of a table wherein public multi-cast addresses and associated private multi-cast addresses are memorised which makes the address association means more complex but creates a greater flexibility in assignment and use of private multi-cast addresses.

[0016] An additional feature of the service node according to the present invention is defined in claim 7.

[0017] Thus, the service node is able to maintain a list of mobile stations which are member of a public multi-cast group. The service node updates the table wherein public multi-cast addresses, private multi-cast addresses and mobile stations are linked upon receipt of join/leave messages sent to it by a gateway node.

[0018] As an alternative to claim 7, claim 8 specifies that the table wherein public multi-cast addresses, private multi-cast addresses and mobile stations are linked may be updated upon receipt of GPRS specific join/leave messages from mobile stations that want to join/leave a public multi-cast group. Such a GPRS specific join/leave message can be interpreted by the service node if its format is standardised.

[0019] The above mentioned and other objects and features of the invention will become more apparent and the invention itself will be best understood by referring to the following description of an embodiment taken in conjunction with the accompanying drawings wherein:

Fig. 1 represents an architectural scheme of a system including gateway nodes GGSN1 and GGSN2 according to the present invention, service nodes SGSN1, SGSN2, SGSN3, SGSN4 and SGSN5 according to the present invention, and routing nodes DPR1, DPR2, DPR3, DPR4, DPR5 and DPR6 according to the present invention;

Fig. 2 illustrates the structure of a private data packet PR-DP multi-casted according to the present invention;

Fig. 3 represents a functional block scheme of an embodiment of the gateway node GGSN1 according to the present invention; and

Fig. 4 represents a functional block scheme of an embodiment of the service node SGSN3 according to the present invention.

[0020] Fig. 1 shows the internet INTERNET and a General Packet Radio Service system GPRS-SYSTEM. The internet INTERNET contains a plurality of IP (Internet Protocol) routers IPR1, IPR2, IPR3 and IPR4 interconnected via links and one terminal TE of the internet INTERNET is also drawn. The General Packet Radio Service system GPRS-SYSTEM contains two Gateway

GPRS Supporting nodes GGSN1 and GGSN2, a number of data packet routers DPR1, DPR2, DPR3, DPR4, DPR5 and DPR6, five Service GPRS Supporting nodes SGSN1, SGSN2, SGSN3, SGSN4 and SGSN5, and five base stations BS1, BS2, BS3, BS4 and BS5. Also six mobile stations or terminals of the GPRS-SYSTEM are drawn in Fig. 1: MS1, MS2, MS3, MS4, MS5 and MS6.

[0021] In the internet INTERNET, the first IP router IPR1 is connected to both the second IP router IPR2 and to the third IP router IPR3. The second IP router IPR2 is connected to the fourth IP router IPR4, the third IP router IPR3 is connected respectively to the first gateway node GGSN1 and to the fourth IP router IPR4, and the just mentioned fourth IP router IPR4 is connected to the second gateway node GGSN2. The terminal TE is interconnected with the second IP router IPR2. In the GPRS-SYSTEM, the first gateway node GGSN 1 is connected to both the first data packet router DPR1 and the second data packet router DPR2. The first data packet router DPR1 additionally is interconnected with the third data packet router DPR3 and the first service node SGSN1, whereas the second data packet router DPR2 is only interconnected with the third service node SGSN3. The third data packet router DPR3 is connected to the first service node SGSN1, the second service node SGSN2 and the third service node SGSN3. These first, second and third service nodes SGSN1, SGSN2 and SGSN3 are respectively connected to the first, second and third base stations BS1, BS2 and BS3. The second gateway node GGSN2 is connected to the fourth data packet router DPR4. This fourth data packet router DPR4 further is connected to the fifth data packet router DPR5 and to the sixth data packet router DPR6. The fifth data packet router DPR5 and the fifth service node SGSN5 are interconnected, and also the sixth data packet router DPR6 and the fourth service node SGSN4 are interconnected. The just mentioned fourth service node SGSN4 is connected to the fourth base station BS4 and the earlier mentioned fifth service node SGSN5 is connected to the fifth base station BS5. The first mobile station MS1 is located within the service area of the first service node SGSN1, the second mobile station MS2 as well as the third mobile station MS3 are located within the service area of the third service node SGSN3. Mobile stations MS4, MS5 and MS6 are all located in the service area of the fifth service node SGSN5.

[0022] In the internet INTERNET data are communicated in accordance with the internet protocol (IP). Data in other words are encapsulated in IP packets PU-DP. Such an IP packet PU-DP is shown in Fig. 2 and contains an overhead section or IP header PU-H and a payload section wherein user data can be embedded. One field of the IP header PU-H carries the address of the destination of the IP data packet PU-DP. In case the IP data packet PU-DP is destined to all members of a multi-cast group, the sender of the IP data packet PU-DP will embed an internet multi-cast address PU-MCA in the

destination address field of that IP data packet PU-DP. The internet terminal TE in Fig. 1 for example is supposed to have sent an IP data packet PU-DP to such a multi-cast group. The IP routers IPR1, IPR2, IPR3 and IPR4 have the task to route IP data packets from their origin to their destination(s). The IP routers IPR1, IPR2, IPR3 and IPR4 thereto look at the contents of the destination address field of the IP data packets they receive and can route the IP data packets either by consulting routing tables or via explicit routing techniques. In case an IP router, IPR1, IPR2, IPR3 or IPR4 receives an IP data packet PU-DP whose destination address field contains an internet multi-cast address PU-MCA, the IP router will multi-cast the data packet PU-DP: the data packet PU-DP is then forwarded to the IP routers that joined the multi-cast tree wherever such IP data packets PU-DP are routed towards all members of the multi-cast group.

[0023] In the GPRS-SYSTEM data packets are routed towards mobile stations in accordance with the GPRS standard specification, where reference is made in the introductory part of this patent application. The gateway nodes GGSN1 and GGSN2 provide interworking with the internet INTERNET, and encapsulate an IP data packet PU-DP received from the internet INTERNET in a private data packet PR-DP that can be routed through the GPRS-SYSTEM towards the destination mobile stations. This operation is known as tunneling. Such a private data packet PR-DP wherein the IP data packet PU-DP is encapsulated, is shown in Fig. 2. This private data packet PR-DP also contains an overhead section PR-H and a payload section wherein the IP data packet PU-DP is embedded. In accordance with the GPRS standard specification, the private data packet PR-DP is a private IP (Internet Protocol) packet and consequently the overhead section PR-H thereof is an IP (Internet Protocol) header wherein also one field is reserved for the destination address of the private data packet PR-DP. As will be explained further, the gateway node GGSN1 that encapsulates the IP data packet PU-DP in the private data packet PR-DP fills the destination address field of the private data packet header PR-H with a private multi-cast address PR-MCA when the destination address field of the IP data packet PU-DP contains an internet multi-cast address PU-MCA.

[0024] The data packet routers DPR1, DPR2, DPR3, DPR4, DPR5 and DPR6 include the functionality to route a private data packet PR-DP to its destination or destinations and, similarly to the IP routers IPR1, IPR2, IPR3 and IPR4 in the internet INTERNET, thereto look at the contents of the destination address field of the private data packets PR-DP and consult routing tables or perform explicit routing techniques. The service nodes SGSN1, SGSN2, SGSN3, SGSN4 and SGSN5 keep track of the locations of the mobile stations and perform mobility security functions and access control compliant with the GPRS standard specification. Via the base stations BS1, BS2, BS3, BS4 and BS5, the service

nodes SGSN1, SGSN2, SGSN3, SGSN4 and SGSN5 are able to set up radio connections to the mobile stations MS1, MS2, MS3, MS4, MS5 and MS6 so that the data packets can be delivered to the mobile stations MS1, MS2, MS3, MS4, MS5 and MS6.

[0025] In the following paragraphs, it will be supposed that the internet terminal TE is the origin of internet data packets PU-DP destined to the members of a multi-cast group with internet multi-cast address PU-MCA. The mobile stations MS1, MS2, MS3, MS4 and MS6 want to receive such data packets and thereto request to become member of this internet multi-cast group. The registration of these mobile stations MS1, MS2, MS3, MS4 and MS6 as members of the multi-cast group, as well as the way wherein the internet data packets PU-DP destined to the members of this multi-cast group are routed towards the mobile stations MS1, MS2, MS3, MS4 and MS6 in accordance with the principles of the present invention will be explained in the next paragraphs. Reference will be made to Fig. 3 and Fig. 4 in these paragraphs to address the required functionality respectively in the gateway nodes GGSN1 and GGSN2 and the service nodes SGSN1, SGSN2, SGSN3, SGSN4 and SGSN5 to be able to fulfil the principles of the present invention.

[0026] Gateway node GGSN1 of Fig. 1 is drawn in more detail in Fig. 3 and includes an internet multi-cast address recognition device PU-RECOGNITION, a multi-cast address association device PU-PR-ASSOCIATION, a private data packet generator PR-GENERATION, a private data packet transmitter PR-TX, a multi-cast address table PU-PR-TABLE, a routing table ROUTING-TABLE, a public join/leave message receiver PU-JN/LV RX, and a private join/leave message generator PR-JN/LV GENERATOR.

[0027] The internet multi-cast address recognition device PU-RECOGNITION, the multi-cast address association device PU-PR-ASSOCIATION, the private data packet generator PR-GENERATION, and the private data packet transmitter PR-TX are cascade coupled between a port of the gateway node GGSN1 where to the third IP router IPR3 is connected in Fig. 1 and a port of the gateway node GGSN1 where to the data packet routers DPR1 and DPR2 of the GPRS-SYSTEM in Fig. 1 are coupled. The multi-cast address table PU-PR-TABLE interfaces with the multi-cast address association device PU-PR-ASSOCIATION, and the routing table ROUTING-TABLE interfaces with the private data packet transmitter PR-TX. The public join/leave message receiver PU-JN/LV RX is connected to the port of gateway node GGSN1 where to data packet routers DPR1 and DPR2 are coupled. The public join/leave message receiver PU-JN/LV RX further is coupled to the private data packet transmitter PR-TX via the private join/leave message generator PR-JN/LV GENERATOR, and also interfaces with the routing table ROUTING-TABLE.

[0028] The service node SGSN3 of Fig. 1 is drawn in more detail in Fig. 4 and includes a private multi-cast

address recognition device PR-RECOGNITION, a private data packet copier and transmitter COPY/SEND, a multi-cast group registration device MS-REGISTRATION, and a private join/leave message receiver PR-JN/LV RX.

[0029] The private multi-cast address recognition device PR-RECOGNITION and the private data packet copier and transmitter COPY/SEND are cascade coupled between a port of the service node SGSN3 that is coupled to the data packet routers DPR2 and DPR3 in Fig. 1, and a port of the service node SGSN3 where to the base station BS3 is coupled. To the port coupled to data packet routers DPR2 and DPR3 also the private join/leave message receiver PR-JN/LV RX is connected and this private join/leave message receiver PR-JN/LV RX has an output terminal coupled to an input terminal the multi-cast group registration device MS-REGISTRATION. The multi-cast group registration device MS-REGISTRATION interfaces with the private data packet copier and transmitter COPY/SEND.

[0030] If the second mobile station MS2 wants to become member of the multi-cast group with internet multi-cast address PU-MCA, it will send a public join message to the service node SGSN3 in whose service area the mobile station MS2 is residing. The service node SGSN3 cannot interpret this public join message and transparently transfers the join message via the data packet routers to gateway node GGSN1. In the gateway node GGSN1, the public join/leave message receiver PU-JN/LV RX receives the public join message and interprets this message. The private multi-cast tree in GPRS-SYSTEM is updated so that the internet data packets PU-DP addressed to the internet multi-cast address PU-MCA will be routed to the mobile station MS2. In addition, the public join message is encapsulated in a private join message by the private join/leave message generator PR-JN/LV GENERATOR and this private join message is sent to the service node SGSN3 in whose service area mobile station MS2 is residing. In this way, the service node SGSN3 is made aware that the mobile station MS2 becomes member of the multi-cast group with the internet multi-cast address PU-MCA and private multi-cast address PR-MCA. Indeed, this multi-cast group is addressed within the GPRS-SYSTEM with a private multi-cast address PR-MCA that is linked to the public multi-cast address PU-MCA via a table PU-PR-TABLE in the gateway node GGSN1 and via the multi-cast group registration device MS-REGISTRATION in the service node SGSN3. The just mentioned multi-cast group registration device MS-REGISTRATION upon instruction of the private join/leave message receiver PR-JN/LV RX memorises that mobile station MS2 becomes member of the multi-cast group with public multi-cast address PU-MCA and private multi-cast address PR-MCA. It is the task of the gateway node GGSN1 to mention to the IP router IPR3 that it wants to join the internet multi-cast group with internet multi-cast address PU-MCA. Similarly to mobile station MS2, mo-

mobile station MS3 will join the public multi-cast group with internet multi-cast address PU-MCA. A public join message is transmitted towards gateway node GGSN1 and returned as a private join message to the service node SGSN3 in whose area the mobile station MS3 is located. In the multi-cast group registration device MS-REGISTRATION it is memorised that mobile station MS3 also wants to receive the private data packets destined to the multi-cast group with public multi-cast address PU-MCA and private multi-cast address PR-MCA. Also mobile stations MS1, MS4 and MS6 become members of the multi-cast group which is addressed by the internet multi-cast address PU-MCA in the INTERNET and which is addressed by the private multi-cast address PR-MCA in the GPRS-SYSTEM. Mobile station MS1 for example is registered as member of this multi-cast group in the service node SGSN1. In a similar way, service node SGSN5 registers that the mobile stations MS4 and MS6 have joined this multi-cast group.

[0031] Summarising, a registration mechanism is provided in the GPRS-SYSTEM whereby the service nodes SGSN 1, SGSN2, SGSN3, SGSN4 and SGSN5 register which mobile terminals MS1, MS2, MS3, MS4 and MS6 joined a public multi-cast group via a join message that is sent to a gateway node and returned thereby as a private join message. In case a mobile station moves to another service area, the registered information must be updated. This update may form part of the inter SGSN routing area update procedure in a cellular mobile system. In case a mobile station wants to be deleted as member of a public multi-cast group, it will send a leave message which is treated in a similar way as the join messages. The service node thereupon de-registers the mobile station as member of the multi-cast group.

[0032] If an internet server or a terminal TE transmits internet data packets PU-DP addressed to members of the internet multi-cast group with internet multi-cast address PU-MCA, these packets will be routed to the gateway nodes GGSN1 and GGSN2 because these gateway nodes joined the multi-cast tree associated with that internet multi-cast group as explained above. The internet multi-cast address recognition device PU-RECOGNITION in gateway node GGSN1 detects that the received internet data packet PU-DP is addressed to the internet multi-cast group by recognising internet multi-cast address PU-MCA in the destination address field of the internet data packet PU-DP. The internet multi-cast recognition device PU-RECOGNITION instructs the multi-cast address association device PU-PR-ASSOCIATION to retrieve from the multi-cast address table PU-PR-TABLE the private multi-cast address PR-MCA that is associated with the internet multi-cast address PU-MCA. This private multi-cast address PR-MCA in an alternative embodiment of the invention without multi-cast address table PU-PR-TABLE may be equal to the public multi-cast address PU-MCA. The internet data packet PU-DP is encapsulated in a private data packet PR-DP by the private data packet generator

PR-GENERATION and is forwarded by the private data packet transmitter PR-TX over the private multi-cast tree addressed via private multi-cast address PR-MCA. The private data packet transmitter PR-TX thereto consults the routing table ROUTING-TABLE. The internet data packet PU-DP, encapsulated in the private data packet PR-DP, consequently is multi-casted once to the service node SGSN3 and not transferred two times to service node SGSN3 because two mobile stations MS2 and MS3 in its service area want to receive this data packet PU-DP. In the service node SGSN3, the private multi-cast address recognition device PR-RECOGNITION recognises the private multi-cast address PR-MCA in the header PR-H of the private data packet PR-DP and thereupon instructs the data packet copier and transmitter COPY/SEND to send copies of the data packet PU-DP to all mobile stations, MS2 and MS3, that are member of the public multi-cast group addressed via the public multi-cast address PU-MCA. The private data packet copier and transmitter COPY/SEND thereto consults the memory of the multi-cast group registration device MS-REGISTRATION. In a similar way as described for mobile stations MS2 and MS3, the public data packet PU-DP will be routed to the mobile station MS1 and will be routed to the mobile stations MS4 and MS6. To transfer the data packet PU-DP to mobile stations MS4 and MS6, the data packet again will be multi-casted only once to service node SGSN5, which will duplicate the data packet PU-DP and send a copy to each one of the mobile stations MS4 and MS6.

[0033] Summarising, the private data packets PR-DP wherein public data packets PU-DP destined to an internet multi-cast group are encapsulated, are multi-casted in the GPRS-SYSTEM up to the level of the service nodes. This is made possible by associating private multi-cast groups with the internet multi-cast groups and by maintaining in the service nodes which mobile stations are member of the different public multi-cast groups. In this way, the required bandwidth for transfer of multi-cast traffic between the gateway nodes and the service nodes of the GPRS-SYSTEM is reduced significantly.

[0034] Although implementation of the invention has been described above for transfer of internet data packets over the internet and over a GPRS system interfacing with the internet, it is clear that the same principles can be applied to transfer for example IP or X.25 data packets over respectively an IP or X.25 network and a UMTS (Universal Mobile Telecommunications System) system, interfacing with the IP or X.25 network. In fact the invention can be applied in any system wherein private mobile data packets tunnel public data packets received from a public or external data packet network towards mobile stations, irrespective of the particular protocol that is used in the public data packet network and the mobile network.

[0035] It is also remarked that introduction of the present invention in a GPRS system is not complex because a GPRS system already uses the Internet Proto-

col to tunnel public data packets from the gateway nodes to the service nodes. Introduction of private multi-cast IP addresses, similar to the public multi-cast group IP addresses that are used in the internet makes the invention feasible. No adaptation of the protocol is required in the GPRS system to enable introduction of the present invention.

[0036] Furthermore it is noticed that the private multi-cast address and public multi-cast address associated with each other can be equal. The association of a private multi-cast address with a public multi-cast address then becomes very simple because no tables are required in the gateway nodes and service nodes. The flexibility in use of private addresses is increased if the private multi-cast address associated with a public multi-cast address is not equal thereto. The link between private and public multi-cast addresses then however has to be memorised in a centralised or distributed database.

[0037] While the principles of the invention have been described above in connection with specific apparatus, it is to be clearly understood that this description is made only by way of example and not as a limitation on the scope of the invention.

Claims

1. Method to transfer public data packets (PU-DP) from an originating terminal (TE) to at least a plurality of mobile stations (MS1, MS2, MS3, MS4, MS6) over a public data packet network (INTERNET) and a mobile data packet network (GPRS-SYSTEM) whereby said public data packets (PU-DP) are multi-casted through said public data packet network (INTERNET) by means of a multi-cast address (PU-MCA) in an overhead section (PU-H) of said public data packets (PU-DP).

CHARACTERISED IN THAT said public data packets (PU-DP) are further multi-casted through at least part of said mobile data packet network (GPRS-SYSTEM) by means of a private multi-cast address (PR-MCA) in an overhead section (PR-H) of private data packets (PR-DP) that tunnel said public data packets (PU-DP) through at least said part of said mobile data packet network (GPRS-SYSTEM).

2. Gateway node (GGSN1) for interfacing between a public data packet network (INTERNET) and a mobile data packet network (GPRS-SYSTEM), said gateway node (GGSN1) comprising:

a. public multi-cast address recognition means (PU-RECOGNITION) to recognise a public multi-cast address (PU-MCA) in an overhead section (PU-H) of public data packets (PU-DP) sent from an originating terminal (TE) to at least a plurality of mobile stations (MS1, MS2, MS3, MS4,

MS6) over said public data packet network (INTERNET) and said mobile data packet network (GPRS-SYSTEM).

CHARACTERISED IN THAT said gateway node (GGSN 1) further comprises:

b. address association means (PU-PR-ASSOCIATION) to associate a private multi-cast address (PR-MCA) with said public multi-cast address (PU-MCA); and

c. private data packet generation means (PR-GENERATION) to generate private data packets (PR-DP) for tunnelling said public data packets (PU-DP) through at least part of said mobile data packet network (GPRS-SYSTEM) towards said mobile stations (MS1, MS2, MS3, MS4, MS6), said private data packets (PR-DP) having said private multi-cast address (PR-MCA) in an overhead section thereof.

3. Gateway node (GGSN 1) according to claim 2, CHARACTERISED IN THAT said gateway node (GGSN 1) further comprises:

d. public join/leave message receiving means (PU-JN/LV RX), adapted to receive a join/leave message from a mobile station (MS2) indicating that said mobile station (MS2) wants to join/leave a public multi-cast group; and

e. private join/leave message generating means (PR-JN/LV GENERATION), coupled to said public join/leave message receiving means (PU-JN/LV RX) and adapted to generate a private data packet for tunnelling said join/leave message from said gateway node (GGSN1) to a service node (SGSN3) of said mobile data packet network (GPRS-SYSTEM) serving said mobile station (MS2).

4. Gateway node (GGSN1) according to claim 2 or claim 3,

CHARACTERISED IN THAT said address association means (PU-PR-ASSOCIATION) is adapted to associate with said public multi-cast address (PU-MCA) a private multi-cast address (PR-MCA) that is equal to said public multi-cast address (PU-MCA).

5. Gateway node (GGSN1) according to claim 2 or claim 3,

CHARACTERISED IN THAT said address association means (PU-PR-ASSOCIATION) is adapted to associate with said public multi-cast address (PU-MCA) a private multi-cast address (PR-MCA) linked to said public multi-cast address (PU-MCA) via a table (PU-PR-TABLE) comprised in said gateway node (GGSN 1).

6. Service node (SGSN3) for serving in a mobile data packet network (GPRS-SYSTEM) data packet communication to mobile stations (MS2, MS3) within a certain service area,

CHARACTERISED IN THAT said service node (SGSN3) comprises:

a. private multi-cast address recognition means (PR-RECOGNITION) to recognise a private multi-cast address (PR-MCA) in an overhead section (PR-H) of private data packets (PR-DP) that tunnel through at least part of said mobile data packet network (GPRS-SYSTEM) public data packets (PU-DP) sent from an originating terminal (TE) over a public data packet network (INTERNET) and said mobile data packet network (GPRS-SYSTEM) to at least a plurality of mobile stations (MS2, MS3) within said service area; and

b. means (COPY/SEND) to generate copies of said public data packets (PU-DP) and to send a copy to each one of said mobile stations (MS2, MS3).

7. Service node (SGSN3) according to claim 6,

CHARACTERISED IN THAT said service node (SGSN3) further comprises:

c. private join/leave message receiving means (PR-JN/LV RX) adapted to receive a private join/leave message indicating that a mobile station (MS2) wants to join/leave a public multi-cast group; and

d. registration means (MS-REGISTRATION), coupled to said private join/leave message receiving means (PR-JN/LV RX), and adapted to register inclusion and deletion of a mobile station (MS2).

8. Service node (SGSN3) according to claim 6,

CHARACTERISED IN THAT said service node (SGSN3) further comprises:

e. GPRS join/leave message receiving means to receive a GPRS message indicating that a mobile station (MS2) wants to join/leave a public multi-cast group; and

f. registration means (MS-REGISTRATION) coupled to said GPRS join/leave message receiving means and adapted to register inclusion and deletion of said mobile station (MS2) to or from said public multi-cast group.

9. Routing node (DPR1, DPR2, DPR3, DPR4, DPR5, DPR6) for routing private data packets (PR-DP) from a gateway node (GGSN1) to at least one service node (SGSN 1, SGSN3) of a mobile data packet network (GPRS-SYSTEM), said private data pack-

ets (PR-DP) being adapted to tunnel public data packets (PU-DP) sent from an originating terminal (TE) over a public data packet network (INTERNET) and said mobile data packet network (GPRS-SYSTEM) to at least a plurality of mobile stations (MS1, MS2, MS3, MS4, MS6),

CHARACTERISED IN THAT said routing node (DPR1, DPR2, DPR3, DPR4, DPR5, DPR6) comprises means to multi-cast said private data packets (PR-DP) by means of a private multi-cast address (PR-MCA) in an overhead section (PR-H) of said private data packets (PR-DP).

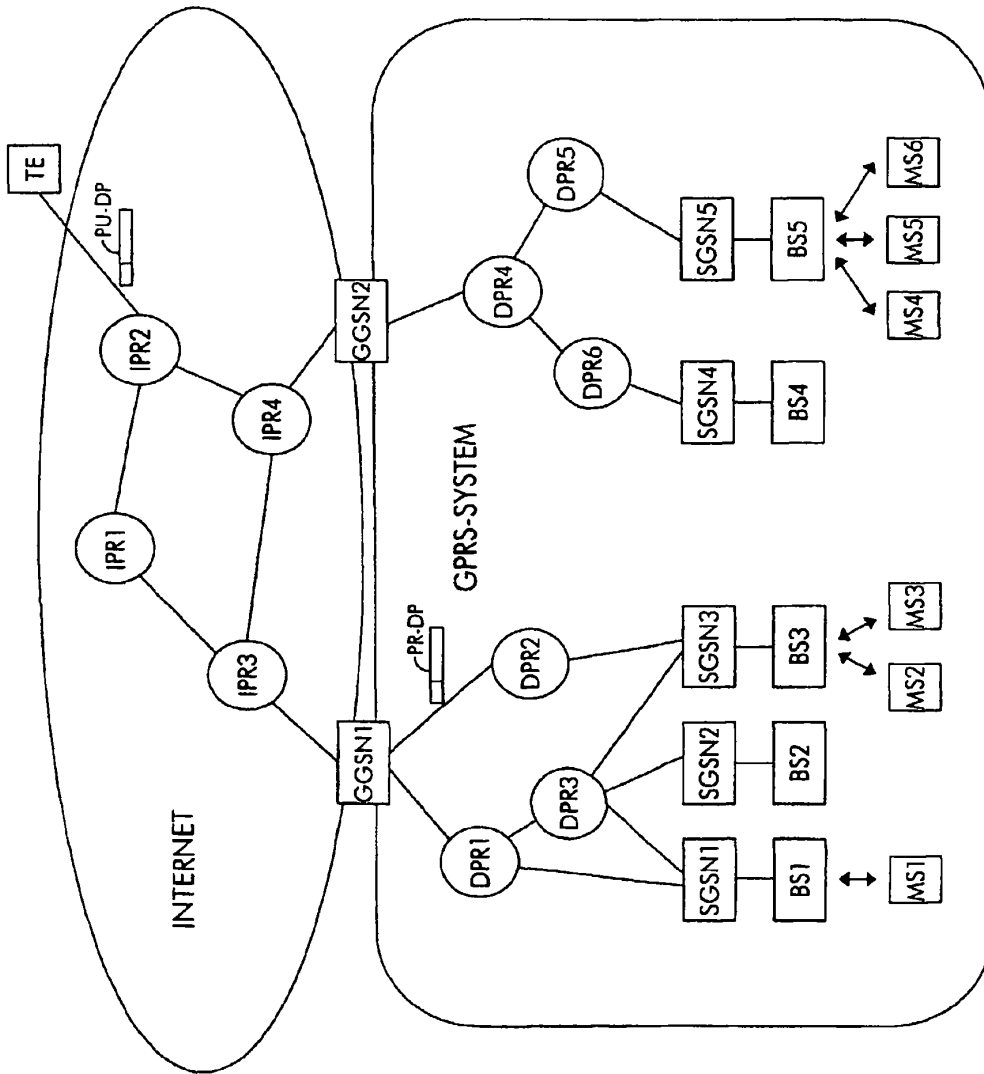

Fig. 1

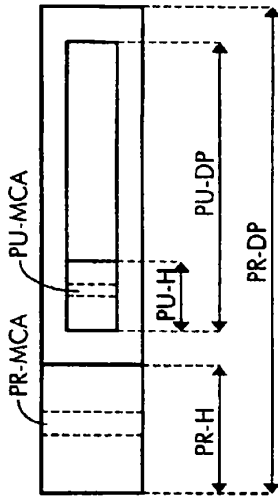

Fig. 2

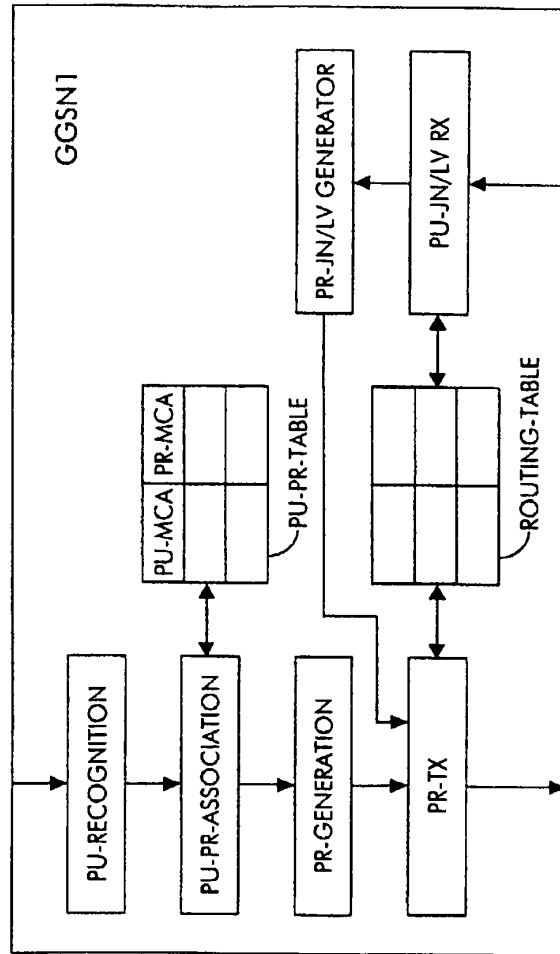

Fig. 3

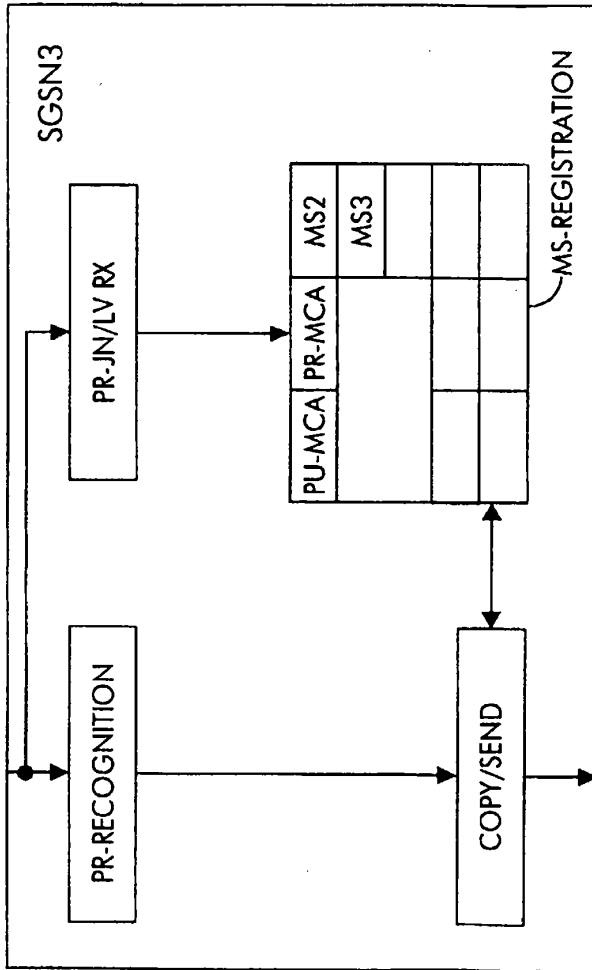

Fig. 4



European Patent Office

EUROPEAN SEARCH REPORT

Application Number
EP 99 40 1864

DOCUMENTS CONSIDERED TO BE RELEVANT			
Category	Citation of document with indication, where appropriate, of relevant passages	Relevant to claim	CLASSIFICATION OF THE APPLICATION (Int.Cl.7)
X	WO 98 25422 A (NOKIA TELECOMMUNICATIONS OY ;HAUMONT SERGE (FI)) 11 June 1998 (1998-06-11) * page 1, line 3 - line 6 * * page 2, line 1 - line 13 * * page 3, line 12 - page 4, line 4 * * page 6, line 21 - line 36 * * page 11, line 3 - line 12 *	1,6-9	H04Q7/22
X	WO 97 21313 A (NORTHERN TELECOM LTD ;SAYERS IAN (GB); RICHARDSON KENNETH (GB)) 12 June 1997 (1997-06-12) * page 2, line 5 - line 20 * * page 5, line 4 - line 19 * * page 6, line 16 - line 35 *	1,2,6,9	
A	BRASCHE G: "EVALUATION OF A MAC PROTOCOL PROPOSED FOR A GENERAL PACKET RADIO SERVICE IN GSM" IEEE INTERNATIONAL SYMPOSIUM ON PERSONAL, INDOOR AND MOBILE RADIO COMMUNICATIONS, vol. 2, 1 May 1996 (1996-05-01), page 668-672 XP000198338 * page 669, left-hand column, line 20 - line 36 * * page 669, right-hand column, line 18 - line 28 *		
The present search report has been drawn up for all claims			TECHNICAL FIELDS SEARCHED (Int.Cl.7)
			H04Q H04L
Place of search	Date of completion of the search	Examiner	
BERLIN	9 December 1999	RothlÜbbers, C	
CATEGORY OF CITED DOCUMENTS		T : theory or principle underlying the invention E : earlier patent document, but published on, or after the filing date D : document cited in the application L : document cited for other reasons & : member of the same patent family, corresponding document	
X : particularly relevant if taken alone Y : particularly relevant if combined with another document of the same category A : technological background O : non-written disclosure P : intermediate document			

EPO FORM 1503 03.92 (P04C01)

**ANNEX TO THE EUROPEAN SEARCH REPORT
ON EUROPEAN PATENT APPLICATION NO.**

EP 99 40 1864

This annex lists the patent family members relating to the patent documents cited in the above-mentioned European search report. The members are as contained in the European Patent Office EDP file on
The European Patent Office is in no way liable for these particulars which are merely given for the purpose of information.

09-12-1999

Patent document cited in search report	Publication date	Patent family member(s)	Publication date
WO 9825422 A	11-06-1998	FI 964818 A	03-06-1998
		AU 5123398 A	29-06-1998
		EP 0947114 A	06-10-1999
WO 9721313 A	12-06-1997	GB 2307827 A	04-06-1997
		GB 2307828 A	04-06-1997

EPO FORM P/438

For more details about this annex : see Official Journal of the European Patent Office, No. 12/82



(12) **EUROPEAN PATENT APPLICATION**

(43) Date of publication:
 16.03.2005 Bulletin 2005/11

(51) Int Cl.7: **H04L 29/06**

(21) Application number: **04021473.6**

(22) Date of filing: **09.09.2004**

(84) Designated Contracting States:
AT BE BG CH CY CZ DE DK EE ES FI FR GB GR
HU IE IT LI LU MC NL PL PT RO SE SI SK TR
 Designated Extension States:
AL HR LT LV MK

(72) Inventor: **Ono, Yoshihiro c/o NEC Corporation**
Tokyo (JP)

(74) Representative: **Glawe, Delfs. Moll**
Patentanwälte
Postfach 26 01 62
80058 München (DE)

(30) Priority: **11.09.2003 JP 2003319910**

(71) Applicant: **NEC CORPORATION**
Tokyo (JP)

(54) **Location based information delivery**

(57) There are provided an information providing system that enables a mobile terminal, when it is located within a communicable area of a wireless access point, to easily acquire information content related to the communicable area, a mobile terminal, a wireless access point, a charging server and an information providing method. When entering an area where information can

be received, a mobile terminal 10 displays that it has entered an area where information can be acquired on the screen of a display section 14. When the mobile terminal user operates the mobile terminal 10 to select a predetermined area on the display, a request to acquire information content is sent to an information providing server 30 via a network 40. The information providing server 30.

FIG.1

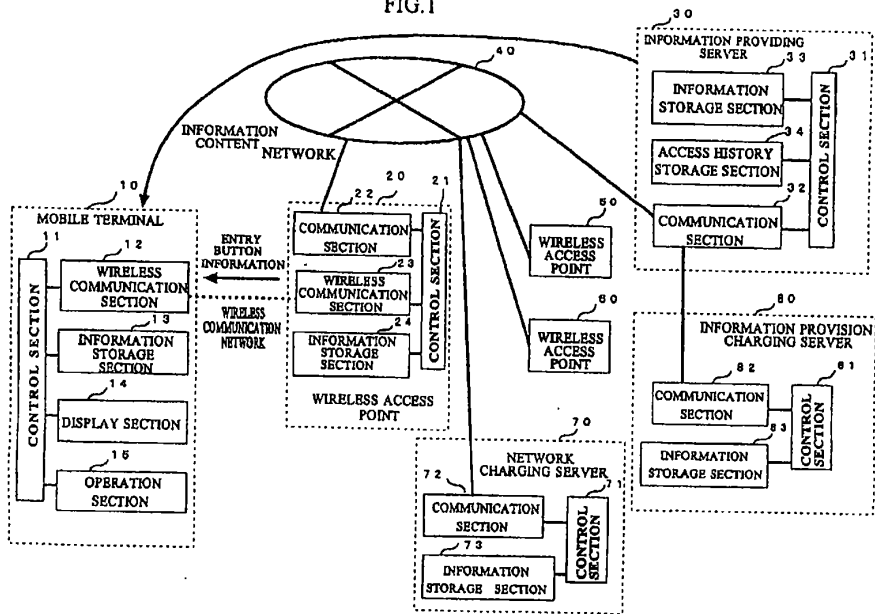

EP 1 515 512 A2

Description**BACKGROUND OF THE INVENTION****Field of the Invention**

[0001] The present invention relates to an information providing system, a mobile terminal, a wireless access point and a charging server used in the system, and an information providing method, and in particular to an information providing system, a mobile terminal, a wireless access point and a charging server used in the system, and an information providing method for delivering information specific to a communicable area of a wireless access point to a mobile terminal located in the communicable area.

Description of the Related Art

[0002] There has been employed a service for providing information related to the current position of a mobile terminal via the Internet. This is a service by utilizing the fact that a server on a network grasps which base station area the mobile terminal belongs to, provide regional information within a base station area to a mobile terminal as a Web service.

[0003] For example, when a mobile terminal sends position information indicating its current position to a server, the server provides web content appropriate for the position based on the position information sent from the mobile terminal. The position information is provided to the mobile terminal from the mobile terminal network side (for example, a home location register (HLR)) as appropriate.

[0004] The range of a base station area in which the regional information is provided is generally a range with a diameter of several kilometers to over ten kilometers and is not a range within which a man can move on foot. That is, according to the above method, the regional web content to be provided is broader than the activity range of a human being, so an appropriate information sometimes cannot be provided for a user located in the area.

[0005] For example, when a user wants to find a restaurant to take a meal in several minutes, the server may provide information about a restaurant which the user cannot access without utilizing transportation part, to the user's mobile terminal.

[0006] As a prior-art technique for providing position-dependent information, Japanese Patent Laid-Open No. 2003-134546 (first document) discloses an information service providing system using attributes of a place.

[0007] In the Document, a wireless access point management apparatus is disclosed, and the apparatus manages position information and place attribute information about a wireless access point. When an mobile terminal sends identification information about the wireless access point notified by the wireless access point

to an information providing apparatus, the information providing apparatus sends the identification information received from the mobile terminal to the wireless access point management apparatus. The wireless access point management apparatus returns the position and place attributes of the mobile terminal to the information providing apparatus, and the information providing apparatus provides information content related to the position and the place attributes to the mobile terminal.

[0008] In the Document, position-dependent information which has been constructed by searching the information is provided to the user on the basis of the position and the place.

[0009] Japanese Patent Laid-Open No. 2002-359863 (second document) is disclosed the information providing method having time and space restrictions. When entering a communicable area where communication with a base station is possible, a mobile terminal automatically detects and notifies that information originated from a base station can be received.

[0010] Conventionally known or employed information providing methods that depend on the position of a mobile terminal have problems. Since provided information from the mobile terminal is based on the geographical range of the position of the mobile terminal, provided information is broad and not necessarily information related to services available to a user of the mobile terminal immediately or within several minutes (problem 1). Since provided information on the basis of the geographical range of the position of the mobile terminal is broad, an information provider provides information even to users who do not desire provision of the information as a result (problem 2). A mobile terminal user is required to perform complicated operations of the terminal such as a search operation before he can access information he needs (problem 3).

[0011] For example, in the conventional service of providing regional information based on a base station area which a mobile phone belongs to, the range of one information providing region is broad (the above problem 1). Therefore, it is difficult for an information provider in the service to provide information to a mobile terminal user whom the information provider wants to provide the information (the above problem 2). Furthermore, the above service has a problem that the operation procedure to be performed by a mobile terminal user with the use of a mobile terminal such as a mobile telephone to obtain information he needs is complicated (the above problem 3).

[0012] In another method for providing position-dependent information, a global positioning system (GPS) is utilized. In this information providing method utilizing GPS, when a mobile terminal sends information about the position it has measured to an information providing server, the information providing server selects information from information in the server and delivers it to the mobile terminal. This information providing method utilizing GPS also has the above problems.

[0013] In the first document, a business entity that provides a place such as a coffee shop, a restaurant or a retailer for installation of a wireless access point or an entity that operates wireless access points has to perform a search processing by an information providing apparatus even when it wants to provide information to a mobile terminal user more directly and more quickly.

[0014] A case is also assumed that a mobile terminal user only needs means for easily acquiring information dependent on a particular position when he wants to acquire the information and does not need, when entering any wireless access point area, acquisition of information dependent on the position.

[0015] Furthermore, in the case where information is delivered whenever a user enters any wireless access point area, communication load on and power consumption by the mobile terminal is caused even when the user does not want to acquire the information, and he may have to pay an extra communication fee for it.

[0016] As described above, according to the prior-art technique disclosed by the first document, in constructing an information providing service to be provided between a mobile terminal user and a wireless access point installation-location provider or a wireless access point operator in consideration of profitability, there is a possibility that it is difficult for an information provider to provide information accurately with a speed expected by a user.

[0017] In the second document, though it is described that various kinds of information is provided in an area in which information originated from each base station can be received, there is no specific description on means for recognizing that a mobile terminal has entered the area and means for delivering information specific to the area to the mobile terminal.

[0018] The present invention has been made in consideration of the above problems, and its object is to provide an information providing system enabling a mobile terminal which is located in a communicable area of a wireless access point to easily acquire information content related to the communicable area, a mobile terminal, a wireless access point, a charging server and an information providing method.

SUMMARY OF THE INVENTION

[0019] To achieve the above object, the present invention is an information providing system comprising a mobile terminal, one or more wireless access points capable of communicating with the mobile terminal via a wireless communication network in respective communicable areas, and an information providing server connected to the wireless access points via a network; the wireless access points having: acquisition request information delivery part for broadcast delivering acquisition request information for acquiring information content related to the respective communicable areas in the respective communicable areas; and the mobile terminal

having: delivered information receiver for receiving the acquisition request information; a display for, when the acquisition request information is received by the acquisition request information receiver, displaying screen information indicating that it is possible to acquire information content related to the communicable area in which the mobile terminal is currently located; and information acquisition request part for sending a request to acquire the information content to the information providing server when the screen information is displayed; and the information providing server having: information content storage for storing one or more pieces of the information content; information content extracting part for receiving the request to acquire the information content from the mobile terminal and extracting appropriate information content from the one or more pieces of information content; and information content sending part for sending the extracted information content to the mobile terminal.

[0020] According to the present invention, the acquisition request information delivery part delivers the acquisition request information including the screen information and address information about information content related to a communicable area in which the acquisition request information is delivered; and the information acquisition request part sends a request to acquire the information content stored at an address shown by the address information.

[0021] According to the present invention, there is provided an information providing system comprising a mobile terminal, one or more wireless access points capable of communicating with the mobile terminal via a wireless communication network in the respective communicable areas, and an information providing server connected to the wireless access points via a network; the wireless access points having: identification information delivery part for broadcast delivering identification information for identifying the access point in the respective communicable areas; and the mobile terminal having: acquisition request information storage for storing one or more pieces of acquisition request information for acquiring information content related to the respective communicable areas; identification information receiver for receiving the identification information; acquisition request information extracting part for, when the identification information is received by the identification information receiver, extracting acquisition request information for acquiring information content related to a communicable area identified by the identification information from the one or more pieces of acquisition request information; a display for displaying screen information indicating that it is possible to acquire information content related to the communicable area in which the mobile terminal is currently located, the screen information being included in the extracted acquisition request information; and information acquisition request part for sending a request to acquire the information content to the information providing server

when the screen information is displayed; and the information providing server having: information content storage for storing one or more pieces of the information content; information content extracting part for receiving the request to acquire the information content from the mobile terminal and extracting appropriate information content from the one or more pieces of information content; and information content sending part for sending the extracted information content to the mobile terminal.

[0022] According to the present invention, the acquisition request information storage stores the acquisition request information including the address information about information content related to a communicable area in which the acquisition request information is delivered; and the information acquisition request part sends a request to acquire the information content stored at an address shown by the address information.

[0023] According to the present invention, if the acquisition request information for acquiring information content related to a communicable area identified by the identification information received by the identification information receiver is not stored in the acquisition request information storage, the display displays screen information indicating that it is possible to acquire the information content; the acquisition request part sends the received identification information to the information providing server; the information content storage stores the one or more pieces of information content in association with the identification information; and the information content extracting part receives the identification information from the mobile terminal and extracts the information content associated with the received identification information.

[0024] According to the present invention, the information providing system has: server information storage for storing the one or more pieces of acquisition request information in association with the identification information; server information extracting part for extracting the acquisition request information associated with the identification information received from the mobile terminal; and server information sending part for sending the extracted acquisition request information to the mobile terminal; and the acquisition request information storage newly stores the acquisition request information sent from the information providing server.

[0025] According to the present invention, the information providing system further comprises an information provision charging server connected to the information providing server; wherein the information providing server has: sending history storage for storing sending history of the information content sent by the information content sending part; and sending history sending part for sending the stored sending history to the information provision charging server; and the information provision charging server has: service use fee calculator for, when receiving the sending history from the information providing server, calculating an information delivery service use fee to be paid from a business entity developing

business related to the information content to a business entity managing the information providing server, based on the received sending history.

[0026] According to the present invention, the service use fee calculator calculates the information delivery service use fee based on information indicating the number of times the information content has been sent by the information content sending part, the information being included in the sending history.

[0027] According to the present invention, the service use fee calculator calculates the information delivery service use fee based on the data amount of the information content.

[0028] According to the present invention, the information providing system further comprises a network charging server connected to the network; wherein the network charging server has network use fee calculator for calculating a fee for use of the network to be paid from a user of the mobile terminal and the business entity managing the information providing server to a business entity managing the network, based on information indicating use condition of the network by the mobile terminal and the information providing server.

[0029] According to the present invention, there is provided a mobile terminal comprising: delivered information receiving part for, in a communicable area enabling communication with a wireless access point, receiving acquisition request information for acquiring information content related to the communicable area; a display for extracting screen information indicating that it is possible to acquire the information content from the received acquisition request information and displaying the screen information; and information acquisition request part for extracting address information about the information content from the received acquisition request information and sending a request to acquire the information content to an address shown by the address information when the screen information is displayed.

[0030] According to the present invention, there is provided a mobile terminal comprising: identification information receiving part for, in a communicable area enabling communication with a wireless access point, receiving identification information for identifying the wireless access point; acquisition request information storage for storing one or more pieces of acquisition request information for acquiring information content related to the communicable area; acquisition request information extracting part for, when the identification information is received by the identification information receiving part, extracting acquisition request information for acquiring information content related to a communicable area identified by the identification information from the one or more pieces of acquisition request information; a display for extracting screen information indicating that it is possible to acquire the information content from the extracted acquisition request information and displaying the screen information; and information acquisition request part for extracting address information about the

information content from the extracted acquisition request information and sending a request to acquire the information content to an address shown by the address information when the screen information is displayed.

[0031] According to the present invention, there is provided a wireless access point for performing wireless communication with a mobile terminal in a communicable area, the wireless access point broadcast delivering, within the communicable area, acquisition request information including screen information indicating that it is possible to acquire information content related to the communicable area and address information about the information content.

[0032] According to the present invention, there is provided a charging server comprising: sending history input part for inputting sending history of sending of information content related to a communicable area of a wireless access point to a mobile terminal performing wireless communication with the wireless access point; and service use fee calculator for calculating an information delivery service use fee to be paid from a business entity developing business related to the information content to a business entity providing a service of sending the information content, based on the inputted sending history.

[0033] According to the present invention, there is provided a charging server comprising: use condition information input part for, when a mobile terminal requests acquisition of information content related to a communicable area of a wireless access point from equipment on the sending side of the information content and acquires the information content as a response to the request via a network, inputting information indicating condition of use of the network by the mobile terminal and the equipment on the sending side of the information content; and network use fee calculator for calculating a fee for use of the network to be paid from a user of the mobile terminal and a business entity sending the information content to a business entity managing the network, based on the inputted network use condition information.

[0034] According to the present invention, there is provided an information providing method, using a mobile terminal, one or more wireless access points capable of communicating with the mobile terminal via a wireless communication network in respective communicable areas, and an information providing server connected to the wireless access points via a network and comprising: an acquisition request information delivery step of the wireless access point broadcast delivering acquisition request information for acquiring information content related to the respective communicable areas in the respective communicable areas; and a delivered information receiving step of the mobile terminal receiving the acquisition request information; a display step of, when receiving the acquisition request information, the mobile terminal displaying screen information indicating that it is possible to acquire information content related

to the communicable area in which the mobile terminal is currently located; an information acquisition request step of the mobile terminal sending a request to acquire the information content to the information providing server when the screen information is displayed; an information content extracting step of the information providing server receiving the request to acquire the information content from the mobile terminal and extracting appropriate information content from the one or more pieces of information content stored in the server; and an information content sending step of the information providing server sending the extracted information content to the mobile terminal.

[0035] According to the present invention, there is provided an information providing method, using a mobile terminal, one or more wireless access points capable of communicating with the mobile terminal via a wireless communication network in respective communicable areas, and an information providing server connected to the wireless access points via a network and comprising: an identification information delivery step of the respective wireless access points broadcast delivering identification information for identifying the respective access points in the respective communicable areas; and an acquisition request information storage step of the mobile terminal storing one or more pieces of acquisition request information for acquiring information content related to the respective communicable areas; an identification information receiving step of the mobile terminal receiving the identification information; an acquisition request information extracting step of, when receiving the identification information, the mobile terminal extracting acquisition request information for acquiring information content related to a communicable area identified by the identification information from the information content related to the one or more communicable areas, the information content being stored in the mobile terminal; a display step of the mobile terminal displaying screen information indicating that it is possible to acquire information content related to the communicable area in which the mobile terminal is currently located, the screen information being included in the extracted acquisition request information; an information acquisition request step of the mobile terminal sending a request to acquire the information content to the information providing server when the screen information is displayed; an information content extracting step of the information providing server receiving the request to acquire the information content from the mobile terminal and extracting appropriate information content from the one or more pieces of information content stored in the server; and an information content sending step of the information providing server sending the extracted information content to the mobile terminal.

[0036] According to the present invention, at the display step, if the acquisition request information for acquiring information content related to a communicable area identified by the identification information received

by the identification information receiving part is not stored in the mobile terminal, the mobile terminal displays screen information indicating that it is possible to acquire the information content; at the acquisition request step, the mobile terminal sends the received identification information to the information providing server; and at the information content extracting step, the information providing server receives the identification information from the mobile terminal and extracts the information content associated with the received identification information from the one or more pieces of information content stored in the server in association with the identification information.

[0037] According to the present invention, the information providing method comprises: a server information extracting step of the information providing server extracting the acquisition request information associated with the identification information received from the mobile terminal from the one or more pieces of acquisition request information stored in the server in association with the identification information; a server information sending step of the information providing server sending the extracted acquisition request information to the mobile terminal; and an acquisition request information storage step of the mobile terminal newly storing the acquisition request information sent from the information providing server in the mobile terminal.

[0038] According to the present invention, the information providing method comprises: a sending history storage step of the information providing server storing sending history of the information content at the information content sending step in the information providing server; a sending history sending step of the information providing server sending the stored sending history to an information provision charging server connected to the information providing server; and a service use fee calculation step of, when receiving the sending history from the information providing server, the information provision charging server calculating an information delivery service use fee to be paid from a business entity developing business related to the information content to a business entity managing the information providing server, based on the received sending history.

[0039] According to the present invention, at the service use fee calculation step, the information provision charging server calculates the information delivery service use fee based on information indicating the number of times the information content has been sent at the information content sending step, the information being included in the sending history.

[0040] According to the present invention, at the service use fee calculation step, the information provision charging server calculates the information delivery service use fee based on the data amount of the information content.

[0041] According to the present invention, the information providing method comprises a network use fee calculation step of the network charging server connect-

ed to the network calculating a fee for use of the network to be paid from a user of the mobile terminal and the business entity managing the information providing server to a business entity managing the network, based on information indicating use condition of the network by the mobile terminal and the information providing server.

[0042] According to the present invention, when located within a communicable area of a wireless access point, a mobile terminal can easily acquire information content related to the communicable area.

BRIEF DESCRIPTION OF THE DRAWINGS

[0043]

FIG. 1 shows the configuration of an information providing system in an Embodiment 1 of the present invention;

FIG. 2 shows network connections in the information providing system of the Embodiment 1 of the present invention;

FIG. 3 is a flowchart showing the flow of an information delivery processing performed by the information providing system in the Embodiment 1 of the present invention;

FIG. 4 shows screen transition of a display section of a mobile terminal in the Embodiment 1 of the present invention, wherein (a) shows a waiting screen display shown by the display section when the mobile terminal is located outside a wireless access point; (b) shows a waiting screen display shown by the display section when the mobile terminal is located within the wireless access point; and (c) shows screen display of information content shown by the display section of the mobile terminal;

FIG. 5 shows an information delivery route and a use fee payment/receipt route in the information providing system in the Embodiment 1 of the present invention;

FIG. 6 is a flowchart showing the flow of a charging processing by an information provision charging server in the Embodiment 1 of the present invention;

FIG. 7 shows an example of a service use condition DB in the Embodiment 1 of the present invention;

FIG. 8 is a flowchart showing the flow of a charging processing by a network charging server in the Embodiment 1 of the present invention;

FIG. 9 shows the configuration of an information providing system in an Embodiment 2 of the present invention;

FIG. 10 shows information to be stored in an information storage section of the mobile terminal in the Embodiment 2 of the present invention;

FIG. 11 shows an access point list in the Embodiment 2 of the present invention;

FIG. 12 shows information to be stored in an infor-

mation storage section of an information providing server in the Embodiment 2 of the present invention;

FIG. 13 shows an SSID list in the Embodiment 2 of the present invention;

FIG. 14 is a flowchart showing the flow of an information delivery processing by the information providing system in the Embodiment 2 of the present invention;

FIG. 15 is a flowchart showing the flow of an information delivery processing by the information providing system in the Embodiment 2 of the present invention;

FIG. 16 shows the configuration of an information providing system in the Embodiment 3 of the present invention;

FIG. 17 shows information to be stored in the information storage section of the information providing server in the Embodiment 3 of the present invention;

FIG. 18 shows an SSID list in the Embodiment 3 of the present invention;

FIG. 19 is a flowchart showing the flow of an information delivery processing by the information providing system in the Embodiment 3 of the present invention; and

FIG. 20 is a flowchart showing the flow of the information delivery processing by the information providing system in the Embodiment 3 of the present invention.

DETAILED DESCRIPTION OF THE PREFERRED EMBODIMENTS

[0044] In embodiments of the present invention, when a mobile terminal enters an area where it can receive information, it displays notification to its user on the screen provided thereon to the effect that it has entered an area where information acquisition is possible. By the mobile terminal user operating the mobile terminal to select a predetermined area on the display by operating the mobile terminal, information is provided to the mobile terminal via a network.

[0045] Furthermore, in the embodiments of the present invention, when a mobile terminal connects to an access point (for example, a wireless LAN access point) via wireless communication, information having content associated with the access point is provided to the mobile terminal.

[0046] When wanting to provide information to a mobile terminal user, a business entity running a business at a place for example, a coffee shop, a restaurant or a retailer where an access point is installed (hereinafter referred to as an AP-installation-location business entity) makes setting by associating the access point with information which the business entity wants to provide.

[0047] In order to provide a user with information with content the user desires at a place he desires, an infor-

mation provider designs an installation location of an access point on a network and sets a range within which connection to the wireless access point is possible, at an information providing server the information provider manages.

[0048] The information providing server then constructs a database in which information indicating the installation location of the access point and information that the AP-installation-location business entity wants to provide (hereinafter referred to as information content) are associated with each other.

[0049] After that, when a mobile terminal enters the area of the wireless access point, it displays notification on its screen that it is within the area of the wireless access point, and it becomes possible to acquire information associated with the area where the mobile terminal is currently located only by selecting the display.

[Embodiment 1]

[0050] FIG. 1 shows the configuration of an information providing system in an Embodiment 1 of the present invention. The configuration and operation of the information providing system in this embodiment will be described below using FIG. 1.

[0051] As shown in FIG. 1, the information providing system is configured to comprise a mobile terminal 10, wireless access points 20, 50 and 60, an information providing server 30, a network 40, a network charging server 70 and an information provision charging server 80.

[0052] The wireless access points 20, 50 and 60, the information providing server 30, the network charging server 70 and the information provision charging server 80 are connected via network 40 (for example, the Internet). The mobile terminal 10 communicates with each wireless access point via a wireless communication network.

[0053] In this embodiment, the wireless communication method used between the mobile terminal 10 and the wireless access points 20, 50 and 60 may be wireless LAN or may be any other wireless communication method.

[0054] The mobile terminal 10 is an information processor capable of wireless communication and may be a portable terminal device such as a mobile phone, a personal handy-phone system (PHS), a personal digital assistant (PDA) or a notebook personal computer (PC). The mobile terminal 10 is operated by a mobile terminal user.

[0055] The mobile terminal 10 is configured to have a control section 11, a wireless communication section 12, an information storage section 13, a display section 14 and an operation section 15.

[0056] The control section 11 controls each portion of the mobile terminal 10, including the wireless communication section 12, the information storage section 13, the display section 14 and the operation section 15. The

control section 11 may be configured to have a central processing unit (CPU) and an area for storing programs for causing the CPU to perform processings.

[0057] The wireless communication section 12 performs near-field wireless communication that does not require high-speed mobile communication, with the wireless access points 20, 50 and 60. The wireless communication section 12 can also perform wide-area wireless communication that enables high-speed mobile communication by dynamically making a selection from wireless base stations (not shown) arranged on the network 40 in advance.

[0058] The information storage section 13 is a portion for storing various information and may be realized by an electrically erasable and programmable read-only memory (EEPROM), for example.

[0059] The display section 14 displays/reproduces received information, information stored in the information storage section 13 and the like. For example, the display section 14 may be a liquid crystal display (LCD) or an organic electroluminescence (EL) display.

[0060] The operation section 15 is a portion for inputting information, which is configured by various key/switch groups.

[0061] The mobile terminal 10 may be provided with a voice output section (for example, a speaker: film type speaker) and a vibration generation section for vibrating the case of the mobile terminal 10, though they are not shown.

[0062] The wireless access points 20, 50 and 60 are communication apparatuses that function as connection points for connecting the mobile terminal 10 to the network 40. Each of the wireless access points is installed by an AP-installation-location business entity. The configuration and operation of the wireless access points 20, 50 and 60 are assumed to be the same. The configuration of the wireless access point 20 will be described here.

[0063] The wireless access point 20 is configured to have a control section 21, a communication section 22, a wireless communication section 23 and an information storage section 24.

[0064] The control section 21 controls each portion of the wireless access point 20, including the communication section 22, the wireless communication section 23 and the information storage section 24. The control section 21 may be configured to have a CPU and an area for storing programs for causing the CPU to perform processings.

[0065] The communication section 22 is a portion for sending and receiving information to and from the information providing server 30 via the network 40.

[0066] The wireless communication section 23 is a portion for sending and receiving information to and from the mobile terminal 10 via a wireless communication network.

[0067] The information storage section 24 is a portion for storing information to be sent to and received from

the mobile terminal 10 and the information providing server 30. The information storage section 24 stores entry button information.

[0068] The entry button information is information for the mobile terminal 10 to acquire information content, which includes entry button screen information and address information.

[0069] The entry button screen information is screen information for the mobile terminal 10 to acquire information content and may be, for example, screen information of an entry button for requesting acquisition of information content, which is realized by a graphical user interface (GUI). The entry button screen information may show information with content related to the place where the wireless access point is installed (for example, a shop), such as the name of or advertisement for the shop.

[0070] The address information is information indicating a storage location of information content on the network 40, that is, a storage location in an information storage section 33 of the information providing server 30. For example, if the network 40 is the Internet, the address information may be a uniform resource locator (URL).

[0071] Though the entry button information is stored in the information storage section 24 in advance in this embodiment, it may be received and stored via the network 40 by each wireless access point.

[0072] For example, in the case where entry button information associated with each access point is stored in the information storage section 33 of the information providing server 30, the wireless access point may periodically inquire of the information providing server 30 via the network 40 whether or not the information providing server 30 holds entry button information associated with the wireless access point.

[0073] In this case, if holding the entry button information associated with the inquiring wireless access point, the information providing server 30 sends the corresponding entry button information to the inquiring wireless access point.

[0074] The wireless access point periodically inquires of the information providing server 30 even after acquisition of the entry button information. If entry button information for the inquiring wireless access point is newly stored in the information providing server 30, the information providing server 30 sends the newly stored entry button information to the inquiring wireless access point. Receiving the new entry button information, the wireless access point updates its stored entry button information with the new entry button information.

[0075] Furthermore, for example, in the case where entry button information associated with each wireless access point is stored in the information storage section 33 of the information providing server 30, when entry button information associated with a wireless access point is newly stored in the information providing server 30, the information providing server 30 may send the

newly stored entry button information to the appropriate wireless access point via the network 40.

[0076] After the wireless access point acquires the entry button information, the information providing server 30 sends, each time entry button information is newly stored therein, the newly stored entry button information to an appropriate wireless access point. Receiving new entry button information, the wireless access point updates its stored entry button information with the new entry button information.

[0077] Though entry button information is stored in the information providing server 30 in the above embodiment, the entry button information may be stored in any other apparatus connected to the network 40 and having a communication function. In this case also, an access point may acquire entry button information by inquiring of the apparatus having a communication function, or the apparatus having a communication function may send, each time entry button information is newly stored therein, the entry button information to a wireless access point.

[0078] The information providing server 30 is an information processor provided with a function of providing information in response to an information acquisition request from the mobile terminal 10, and may be a high-end PC such as a workstation, for example. The information providing server 30 is managed by an information provider.

[0079] The information providing server 30 is configured to have a control section 31, a communication section 32, an information storage section 33 and an access history storage section 34.

[0080] The control section 31 controls each portion of the information providing server 30, including the communication section 32, the information storage section 33 and the access history storage section 34. The control section 31 may be configured to have a CPU and an area for storing programs for causing the CPU to perform processings.

[0081] The communication section 32 is a portion for sending and receiving information to and from the wireless access points 20, 50 and 60 via the network 40.

[0082] The information storage section 33 is a portion for storing information to be sent and received via the network 40. The information storage section 33 stores information content together with an information content ID, which is identification information for identifying each information content. The information content may show the content of and advertisement for a business such as running of a shop developed by an AP-installation-location business entity within the area of a wireless access point installed by the AP-installation-location business entity.

[0083] The access history storage section 34 stores the number of times a request to acquire information content stored in the information storage section 33 is received by the communication section 32 (or the number of times the information content is sent in re-

sponse to an acquisition request) is stored for each information content for each information content ID.

[0084] The network charging server 70 is an information processor managed by a network business entity such as an Internet service provider (ISP), and may be realized by a high-end PC such as a workstation. The network charging server 70 performs a charging processing for a fee for use of the network 40 by a mobile terminal user or an information provider.

[0085] The network charging server 70 is configured to have a control section 71, a communication section 72 and an information storage section 73.

[0086] The control section 71 controls each portion of the network charging server 70, including the communication section 72 and the information storage section 73. The control section 71 may be configured to have a CPU and an area for storing programs for causing the CPU to perform processings.

[0087] The control section 71 calculates a fee for use of the network 40 to be paid from a mobile terminal user or an information provider to the network business entity.

[0088] The communication section 72 receives information indicating condition of use of the network 40 (hereinafter referred to as network use condition information) from the information providing server 30 and an ISP server (not shown) via the network 40.

[0089] In this case, the ISP server is an information processor managed by a network business entity such as an ISP, and may be realized by a high-end PC such as a workstation, for example. Receiving a network connection request from a mobile terminal 10, the ISP server connects the mobile terminal 10 to the network 40.

[0090] The information storage section 73 is a portion for storing network use condition information received via the network 40 and network use fee information calculated by the control section 71.

[0091] The information provision charging server 80 is an information processor managed by an information provider, and may be realized by a high-end PC such as a workstation, for example. The information provision charging server 80 calculates an information delivery service use fee to be paid from an AP-installation-location business entity to an information provider. In this case, the information delivery service is a network service of the information providing server 30 delivering information content related to the business of the AP-installation-location business entity.

[0092] The information provision charging server 80 is configured to have a control section 81, a communication section 82 and an information storage section 83.

[0093] The control section 81 controls each portion of the information provision charging server 80, including the communication section 82 and the information storage section 83. The control section 81 may be configured to have a CPU and an area for storing programs for causing the CPU to perform processings. The control section 81 calculates an information delivery service

use fee.

[0094] The communication section 82 is connected to the communication section 32 of the information providing server 30 via a network. The communication section 82 receives service use condition information indicating the condition of use of the information delivery service by a mobile terminal user from the information providing server 30.

[0095] The information storage section 83 stores the service use condition information about each mobile terminal user received from the communication section 82 and the service use fee information calculated by the control section 81.

[0096] FIG. 2 shows network connections in the information providing system of the Embodiment 1 of the present invention.

[0097] As shown in FIG. 2, a mobile terminal 10 is assumed to move from position P1 to P2, and then to P3 in that order.

[0098] At the position P1, the mobile terminal 10 is located outside the access point area (outside the communicable area) of the wireless access point 20. Therefore, wireless communication is not established and the mobile terminal 10 is not connected to the network 40. In this case, the display section 14 of the mobile terminal 10 does not show screen display indicating that information content can be acquired.

[0099] When the mobile terminal 10 moves from position P1 to position P2, wireless communication is established because the mobile terminal had entered the access point area (the communicable area), and the mobile terminal 10 is connected to the network 40. In this case, the display section 14 of the mobile terminal 10 shows screen display indicating that information content can be acquired.

[0100] When the mobile terminal 10 moves from position P2 to position P3, it gets out of the access point area, and therefore wireless communication cannot be established. In this case, the display section 14 of the mobile terminal 10 eliminates screen display indicating that information content can be acquired, which has been shown when the mobile terminal was in the access point area.

[0101] According to this embodiment, an access point area is an area around a wireless access point with a radius of dozens of meters to 100 meters in which a user can move on foot in a several minutes.

[0102] FIG. 3 is a flowchart showing the flow of an information delivery processing performed by the information providing system in the Embodiment 1 of the present invention. Description will be made below on the information delivery processing by the information providing system in this embodiment, along the flowchart of FIG. 3 and with reference to FIG. 1.

[0103] First, the wireless communication section 23 of the wireless access points 20 broadcast delivers entry button information in its access point area (step S101).

[0104] The control section 11 of the mobile terminal

10 determines whether the entry button information has been received by the wireless communication section 12 (step S102).

[0105] If the mobile terminal 10 is located within the wireless access point area and it is determined that the entry button information has been received (step S102: Yes), then the display section 14 displays entry button screen information included in the received entry button information (step S103).

[0106] When displaying the entry button screen information, the mobile terminal 10 may output a voice for notifying the mobile terminal user that it has entered the wireless access point area, or it may vibrate the case to notify that it has entered the area.

[0107] FIG. 4 shows screen transition of the display section 14 of the mobile terminal 10 in the Embodiment 1 of the present invention. FIG. 4 (a) shows a waiting screen display shown by the display section 14 when the mobile terminal 10 is located outside a wireless access point; (b) shows a waiting screen display shown by the display section 14 when the mobile terminal 10 is located within the wireless access point; and (c) shows screen display of information content by the display section 14 of the mobile terminal 10.

[0108] As shown in FIG. 4 (a) and (b), when the mobile terminal 10 moves into the access point area of the wireless access point 20 from outside the access point area, the wireless communication section 12 receives entry button information which is broadcast delivered from the wireless access point 20, and the display section 14 displays the received entry button (a box with "Spot Information" thereon in the case of FIG. 4 (b)).

[0109] In FIG. 4 (a), since the mobile terminal 10 is outside the access point area, the display is not shown.

[0110] Then, when the mobile terminal user operates the operation section 15 to select the entry button on the screen (step S104: Yes), the wireless communication section 12 sends a request to acquire information content to the address of an information content delivery source that has been received together with the entry button screen information (that is, the address referring to the inside of an information providing server) (step S105).

[0111] When the communication section 32 of the information providing server 30 receives the request to acquire information content from the mobile terminal 10 (step S106: Yes), the control section 31 extracts information content at the address specified by the acquisition request from the information storage section 33 (step S107).

[0112] The communication section 32 then delivers the extracted information content to the mobile terminal 10 (step S108).

[0113] When the wireless communication section 12 of the mobile terminal 10 receives the delivered information content (step S109: Yes), the information storage section 13 stores the received information content. Then, the display section 14 displays the received infor-

mation content (step S110).

[0114] FIG. 4 (c) shows an example of display by the display section 14, of the received information content. By further making a selection from various items (displayed by GUI and the like) such as "Recommendation Information" and "Special Bargains" shown in the information content, the mobile terminal 10 can acquire other information content (such as web pages) stored in the information providing server 30.

[0115] In this way, the mobile terminal user acquires information content specific to the wireless access point 20, within the access point area where he is located. Thus, it is possible for the terminal mobile user to easily acquire information about shops and the like in the neighborhood of the position where he is currently located.

[0116] The control section 11 may generate an entry button list, information indicating a list of entry button information stored in the information storage section 13 and the information storage section 13 may store the list.

[0117] In this case, by the mobile terminal user operating the operation section 15 to display the entry button list on the display section 14 and selecting entry button information for information content he wants to acquire from the list, the display section 14 displays the selected entry button screen information.

[0118] Thus, it is possible for the mobile terminal user to acquire information content he desires even if he moves out of the wireless access point 20.

[0119] The request to acquire information content and the information content may be sent and received via a wireless access point or via a base station (not shown) of the network 40.

[0120] FIG. 5 shows an information delivery route and a use fee payment/receipt route in the information providing system in the Embodiment 1 of the present invention. Delivery of information content and payment/receipt of a use fee will be described below using FIG. 5.

[0121] An AP-installation-location business entity installs a wireless access point at a place where the entity runs his business. For example, the AP-installation-location business entity installs a wireless access point so that a shop that the business entity runs is located within the area of the wireless access point.

[0122] Furthermore, the AP-installation-location business entity requests an information provider to create information content which the business entity wants to provide to mobile terminal users via the wireless access point in a data format which can be delivered to mobile terminals (for example, in HTML) and hold them in the information providing server 30.

[0123] The AP-installation-location business entity may create information content using an information processor such as a PC and send them to the information providing server 30 via a network.

[0124] Alternatively, the AP-installation-location business entity may use an information processor to send a request of creation of information content related to the

business the business entity runs to an information processor (such as a PC) of an information provider. In this case, the information provider creates the requested information content using an information processor and registers the created information content with the information providing server 30 connected via a network.

[0125] The information provision charging server 80 charges an information delivery service use fee (a fee for use of information content management/delivery services by the information providing server 30) to be paid from the AP-installation-location business entity to the information provider.

[0126] When information content the delivery of which has been requested by the AP-installation-location business entity is registered with the information storage section 33 of the information providing server 30, the information provider operates an information processor (such as a PC) connected to the information provision charging server 80 to set and input a fee structure for use of the information delivery service for the registered information content. Information indicating the fee structure for the service use fee is stored in the information storage section 83 for each information content.

[0127] A fixed fee system may be employed in which a fee is fixed for a predetermined period, such as a certain amount of yen per month. In addition, the fixed service use fee may be set higher as the data amount of the information content increases.

[0128] The service use fee structure may be a metered rate structure in which a fee depends on the number of accesses to information content from the mobile terminal 10. Furthermore, the service use fee structure may be such that a fee depends on a value obtained by multiplying the number of accesses by the data amount of information content.

[0129] The network charging server 70 charges a network use fee (a fee for use of connection to the network 40) to be paid from an information provide or a mobile terminal user to a network business entity.

[0130] When having concluded a contract for use of the network 40 with a mobile terminal user or an information provider, a network business entity operates an information processor (such as PC) connected to the network charging server 70 to set and input a network use fee structure. Information indicating the network use fee structure is stored in the information storage section 73 for each user or business entity.

[0131] A fixed fee system may be employed for the network use fee structure, in which a fee is fixed for a predetermined period, such as 1 month XX dollars (xx yen).

[0132] A metered rate may be employed which depends on the condition of use of the network 40 by each user or business entity.

[0133] A fixed fee contract and a metered rate contract may be independently applicable to each of the three fees of the information delivery service use fee, the network use fee paid from an information provider

to a network business entity, and the network use fee paid from a mobile terminal user to a network business entity.

[0134] FIG. 6 is a flowchart showing the flow of a charging processing by the information provision charging server 80 in the Embodiment 1 of the present invention. Description will be made below on the charging processing to be performed by the information provision charging server 80 in the case where a service use fee is determined based on a metered rate structure, along the flowchart of FIG. 6.

[0135] First, the control section 31 of the information providing server 30 counts up the number of deliveries by incrementing it by one each time it delivers information content to the mobile terminal 10 in response to an acquisition request of the mobile terminal 10, and writes the number as the number of accesses in the access history storage section 34 for each information content (step S201).

[0136] Then, the communication section 32 of the information providing server 30 sends information content delivery history to the information provision charging server 80, for example, periodically (step S202).

[0137] In this case, the information content delivery history is assumed to include at least an information content ID for identifying each information content and information indicating the number of accesses to information content identified by the ID.

[0138] When the communication section 82 of the information provision charging server 80 receives the information content delivery history (step S203: Yes), the control section 81 writes the value of the number of accesses included in the received delivery history to a service use condition database (hereinafter referred to as a service use condition DB) managed by the information storage section 83 based on the information content ID which is also included in the delivery history.

[0139] FIG. 7 shows an example of the service use condition DB in the Embodiment 1 of the present invention. In the service use condition DB, for each information content, the ID of the information content, the ID of an AP-installation-location business entity that requested delivery of the information content, the data amount of the information content and the number of accesses to the information content are managed, as shown in FIG. 7.

[0140] The control section 81 calculates a service use fee with reference to the service use condition DB, for example, periodically (step S205).

[0141] For example, the control section 81 may calculate the service use fee by multiplying a basic fee which is a base for the fee by the number of accesses or may calculate the service use fee by further multiplying the value obtained by multiplying the basic fee by the number of accesses, by a coefficient based on the data amount of the information content.

[0142] It is assumed that information indicating the basic fee and the coefficient based on the data amount

described above is stored in the information storage section 83 in advance and the control section 81 uses the information to calculate the service use fee. A larger number is assumed to be set as the above coefficient as the data amount is larger.

[0143] The information provision charging server 80 then sends the calculated fee information to a server and the like managed by a financial institution to request payment of the fee, and finishes the processing (step S206).

[0144] FIG. 8 is a flowchart showing the flow of a charging processing by the network charging server 70 in the Embodiment 1 of the present invention. Description will be made below on the charging processing to be performed by the network charging server 70 in the case where a network use fee is determined based on a metered rate structure, along the flowchart of FIG. 8.

[0145] First, an ISP server sends information about use of the network 40 by a mobile terminal user or an information provider together with a user ID for identifying each user or business entity to the network charging server 70 via a network, for example, periodically (step S301).

[0146] The network use condition information includes at least a network utilizing equipment ID for identifying equipment (such as the mobile terminal 10 and the information providing server 30) which utilized the network 40. The network use condition information may include information indicating the data amount of information (including an information acquisition request, information content, entry button information and the like) sent by the mobile terminal 10 or the information providing server 30 with the use of the network 40 or the time required for connection to the network 40 by the mobile terminal 10 or the information providing server 30.

[0147] When the communication section 72 of the network charging server 70 receives the network use condition information (step S302: Yes), the control section 71 writes the received network use condition information to the information storage section 73 based on the user ID received at the same time (step S303).

[0148] Then, the control section 71 calculates a network use fee based on the network use condition information in the information storage section 73, for example, periodically (step S304).

[0149] For example, the control section 71 may calculate the network use fee by adding a fee dependent on the network use condition to a basic fee which is a base for the fee.

[0150] It is assumed that information indicating the above-mentioned fee dependent on the network use condition is stored in the information storage section 83 in advance and the control section 81 uses the information to calculate a network use fee.

[0151] A larger number is assumed to be set as information indicating the above-mentioned fee dependent on the use condition as the data amount of information sent with the use of the network 40 is larger and the time

required for connection to the network 40 is longer.

[0152] Then, the network charging server 70 sends the calculated fee information to a server and the like managed by a financial institution to request payment of the fee, and finishes the processing (step S305).

[0153] Though an AP-installation-location business entity that runs its business at a place located within a wireless access point area installs the wireless access point in this embodiment, any other business entity may install the wireless access point.

[0154] For example, a specialized AP installer that runs an intermediary service business between an entity that develops a business such as running a shop (hereinafter referred to as a business developing entity) and an information provider may install a wireless access point.

[0155] The specialized AP installer is a business entity specialized in installation of wireless access points. When the specialized AP installer accepts an order for use of an information content delivery service from one or more business entities developing businesses within the area of a wireless access point installed by the specialized AP installer, the specialized AP installer places an order for the received order to an information provider.

[0156] Specifically, when an information processor operated by a specialized AP installer receives a request to use a delivery service (which may be accompanied with information content the delivery of which is desired) from an information processor of a business developing entity via a network, it may send the received use request to the information providing server 30.

[0157] An information provider running an information content delivery business may install a wireless access point. In this case, the information provider requests a business developing entity to provide a place for installation of a wireless access point on condition that it performs network delivery of information content related to the business of the business developing entity.

[0158] A network business entity running a business of providing use of the network 40 may install a wireless access point. In this case, the network business entity requests a mobile terminal user (or an organization to which the user belongs) to provide a place for installation of a wireless access point on condition that it provides more satisfactory network services (such as a capability of using a wireless LAN) for the mobile terminal user (or the organization to which the user belongs).

[0159] There may exist an AP aggregator that runs an intermediary business between one or more business developing entities and an information provider by aggregating wireless access points installed by the one or more business developing entities.

[0160] The AP aggregator is an entity that runs a business of brokering an information delivery service of an information provider when a business developing entity wants to deliver information within the area of a wireless access point installed by the business developing entity.

[0161] It is possible for the AP aggregator to develop

network services and information providing services specific to the AP aggregator within the areas of the one or more aggregated wireless access points.

[0162] As described above, according to this embodiment, it is possible for an AP-installation-location business entity to appropriately provide information content that the AP-installation-location business entity wants to provide to a mobile terminal user at a place where its wireless access point 20 is installed.

[0163] The reason is that the wireless access point 20 and the information providing server 30 for delivering information content dependent on the place where the wireless access point 20 is installed are arranged on the network 40.

[0164] Furthermore, according to this embodiment, it is possible for a mobile terminal user to acquire information content dependent on the place where the wireless access point 20 is installed with an easy operation procedure.

[0165] The reason is that, when the mobile terminal 10 enters a wireless access point area, an entrance display (entry button) to information content associated with the wireless access point is displayed on the display section 14 of the mobile terminal 10.

[Embodiment 2]

[0166] Description will be now made on the assumption that the configuration and operation of an Embodiment 2 of the present invention are the same as in the Embodiment 1 unless otherwise specified. In this embodiment, the wireless communication method used between the mobile terminal 10 and the wireless access points 20, 50 and 60 is assumed to be a wireless LAN.

[0167] An access point area is an area around a wireless access point with a radius of dozens of meters to 100 meters the same as in the Embodiment 1.

[0168] FIG. 9 shows the configuration of an information providing system in the Embodiment 2 of the present invention. Those denoted by the same reference numerals as in the information providing system of the Embodiment 1 shown in FIG. 1 are assumed to have the same configuration and perform the same operation unless otherwise specified.

[0169] In the Embodiment 1, the wireless access point 20 broadcast delivers entry button information within its access point area. In contrast, in this embodiment, a service set ID (SSID), an identifier for identifying each access point, is stored in the information storage section 24 of each wireless access point as shown in FIG. 9, and the wireless communication section 23 broadcast delivers the SSID within its access point area.

[0170] FIG. 10 shows information to be stored in the information storage section 13 of the mobile terminal 10 in the Embodiment 2 of the present invention. As shown in FIG. 10, an access point list and entry button screen information is stored in the information storage section 13.

[0171] FIG. 11 shows the access point list in the Embodiment 2 of the present invention. As shown in FIG. 11, the access point shows a list of one or more SSIDs.

[0172] The mobile terminal 10 may download and acquire the access point list from the information providing server 30 by sending an acquisition request to the information providing server 30 via the network 40.

[0173] As shown in FIG. 10, the entry button information to be stored in the information storage section 13 includes one or more pieces of entry button information each of which corresponds to each SSID in the access point list and default entry button information corresponding to SSIDs that do not exist in the access point list.

[0174] The one or more entry button information each of which corresponds to each SSID includes entry button screen information and address information indicating the storage location of information content the same as in the Embodiment 1.

[0175] The entry button screen information associated with an SSID in the access point list may show information related to the place (for example, a shop) where the wireless access point having broadcast delivered the SSID is installed, such as the name of or advertisement for the shop, the same as in the Embodiment 1.

[0176] The default entry button information includes entry button screen information and address information indicating the address of the information providing server 30.

[0177] The default entry button screen information may show only an entry button.

[0178] The default address information is not an address indicating a storage location of information content but simply an address on the network 40, of the information providing server 30.

[0179] FIG. 12 shows information to be stored in the information storage section 33 of the information providing server 30 in the Embodiment 2 of the present invention. As shown in FIG. 12, information content related to the place where each wireless access point is installed and an SSID list are stored in the information storage section 33 of the information providing server 30 the same as in the Embodiment 1.

[0180] FIG. 13 shows the SSID list in the Embodiment 2 of the present invention. As shown in FIG. 13, the SSID list is a table in which each SSID and address information indicating the storage location in the information providing server 30 of information content corresponding to each SSID are associated with each other.

[0181] FIGS. 14 and 15 are flowcharts showing the flow of an information delivery processing by the information providing system in the Embodiment 2 of the present invention. Description will be made below on the information delivery processing by the information providing system in this embodiment, along the flowcharts of FIGS. 14 and 15 and with reference to FIG. 9.

[0182] First, the wireless communication section 23 of the wireless access point 20 broadcast delivers an

SSID within the area of the access point 20 (step S401).

[0183] The control section 11 of the mobile terminal 10 determines whether or not the SSID has been received by the wireless communication section 12 (step S402).

[0184] If the mobile terminal 10 is located within the wireless access point area and it is determined that the SSID has been received (step S402: Yes), then the control section 11 refers to the access point list in the information storage section 13 and determines whether or not there exists an SSID associated with the received SSID in the access point list (step S403).

[0185] If it is determined that there exists an SSID associated with the received SSID in the access point list (step S403: Yes), then the control section 11 extracts entry button screen information associated with the corresponding SSID from the information storage section 13 (step S404).

[0186] Then, the display section 14 displays the extracted entry button screen information (step S405).

[0187] Then, when the mobile terminal user operates the operation section 15 to select the entry button on the screen (step S406: Yes), the wireless communication section 12 sends a request to acquire information content to the address of the storage location of information content, which is shown in the address information associated with the entry button screen information (that is, the address referring to the inside of an information providing server) (step S407).

[0188] On the contrary, if it is determined that there is no SSID associated with the received SSID in the access point list (step S403: No), then the control section 11 extracts default entry button screen information from the information storage section 13 (step S408).

[0189] Then, the display section 14 displays the extracted default entry button screen information (step S409).

[0190] Then, when the mobile terminal user operates the operation section 15 to select the entry button on the screen (step S410: Yes), the wireless communication section 12 sends a request to acquire information content to the address associated with the default entry button screen information (that is, to the information providing server 30) together with the SSID received from the wireless access point 20 (step S411).

[0191] When the communication section 32 of the information providing server 30 receives the request to acquire information content from the mobile terminal 10 (step S412: Yes), the control section 31 determines whether or not the address information indicating the storage location of information content has been received by the communication section 32 together with the acquisition request (step S413).

[0192] If it is determined that the address information indicating the storage location of information content has been received together with the acquisition request (step S413: Yes), then the control section 31 extracts the information content specified by the address infor-

mation from the information storage section 33 (step S414).

[0193] If it is determined that the address information indicating the storage location of information content has not been received together with the acquisition request (step S413: No), then the control section 31 refers to the SSID list in the information storage section 33 to detect an address of information content associated with the SSID received together with the acquisition request (step S415).

[0194] Then, the control section 31 extracts appropriate information content from the information storage section 33 based on the detected address (step S416).

[0195] Then, the communication section 32 delivers the extracted information content to the mobile terminal 10 (step S417).

[0196] When the wireless communication section 12 of the mobile terminal 10 receives the delivered information content (step S418: Yes), the information storage section 13 stores the received information content. Then, the display section 14 displays the received information content (step S419).

[0197] In this way, the mobile terminal user acquires information content specific to the wireless access point 20, within an access point area where he is located. Thus, it is possible for the terminal mobile user to easily acquire information about shops and the like in the neighborhood of the position he is currently located.

[0198] As described above, according to this embodiment, the mobile terminal 10 receives from a wireless access point an SSID specific to the access point, reads entry button screen information associated with the received SSID from within the mobile terminal itself, and displays it.

[0199] Furthermore, if the mobile terminal 10 does not hold entry button information associated with the received SSID, it sends the SSID together with an acquisition request to the information providing server 30. The information providing server 30 sends information content associated with the SSID received from the mobile terminal 10 to the mobile terminal 10.

[0200] As described above, the mobile terminal 10 acquires information content from the information providing server 30 using entry button information stored in itself in advance, so that the amount of data communicated between the mobile terminal 10 and a wireless access point can be reduced.

[Embodiment 3]

[0201] Description will be now made on the assumption that the configuration and operation of an Embodiment 3 of the present invention are the same as in the Embodiment 2 unless otherwise specified.

[0202] FIG. 16 shows the configuration of an information providing system in the Embodiment 3 of the present invention. Those denoted by the same reference numerals as in the information providing system

of the Embodiment 2 shown in FIG. 9 are assumed to have the same configuration and perform the same operation unless otherwise specified.

[0203] In the Embodiment 2, if receiving an SSID from the mobile terminal 10, the information providing server 30 extracts information content associated with the received SSID and delivers it to the mobile terminal 10. In contrast, in this embodiment, if receiving an SSID from the mobile terminal 10, the information providing server 30 not only extracts information content the same as in the Embodiment 2 but also extracts entry button information associated with the received SSID, and delivers the extracted information content and entry button information to the mobile terminal 10.

[0204] FIG. 17 shows information to be stored in the information storage section 33 of the information providing server 30 in the Embodiment 3 of the present invention. As shown in FIG. 17, in addition to information content related to the installation place of each wireless access point and an SSID list, entry button information associated with each information content is also stored in the information storage section 33 of the information providing server 30.

[0205] FIG. 18 shows the SSID list in the Embodiment 3 of the present invention. As shown in FIG. 18, the SSID list in this embodiment is a table in which each SSID, address information indicating the storage location in the information providing server 30 of information content corresponding to each SSID and address information indicating the storage location in the information providing server 30 of entry button information corresponding to each SSID are associated with one another.

[0206] FIGS. 19 and 20 are flowcharts showing the flow of an information delivery processing by the information providing system in the Embodiment 3 of the present invention. Description will be made below on the information delivery processing by the information providing system in this embodiment, along the flowcharts of FIGS. 19 and 20 and with reference to FIG. 16.

[0207] Since the processing at steps S501 to S512 of FIG. 19 is similar to the processing at steps S401 to S412 of FIG. 14, description thereof will be omitted. The processing at and after step S513 of FIG. 20 will be described below.

[0208] When the communication section 32 of the information providing server 30 receives a request to acquire information content from the mobile terminal 10 (step S512: Yes), the control section 31 determines whether or not address information indicating the storage location of the information content has been received by the communication section 32 together with the acquisition request (step S513).

[0209] If it is determined that the address information indicating the storage location of information content has been received together with the acquisition request (step S513: Yes), then the control section 31 extracts information content specified by the address information from the information storage section 33 (step S514).

[0210] Then, the communication section 32 delivers the extracted information content to the mobile terminal 10 (step S517).

[0211] On the contrary, if it is determined that the address information indicating the storage location of information content has not been received together with the acquisition request (step S513: No), then the control section 31 refers to the SSID list in the information storage section 33 to detect an address of information content associated with the SSID received together with the acquisition request (step S516).

[0212] Then, the control section 31 extracts appropriate information content from the information storage section 33 based on the detected address (step S517).

[0213] Then, the control section 31 refers to the SSID list in the information storage section 33 to detect an address of entry button information associated with the SSID received together with the acquisition request (step S518).

[0214] The control section 31 extracts appropriate entry button information from the information storage section 33 based on the detected address (step S519).

[0215] Then, the communication section 32 delivers the extracted information content and entry button information to the mobile terminal 10 (step S520).

[0216] The control section 11 of the mobile terminal 10 determines whether or not the entry button information has been received by the wireless communication section 12 from the information providing server 30 (step S521).

[0217] If it is determined that the entry button information has not been received (step S521: No), then the process proceeds to step S523.

[0218] If it is determined that the entry button information has been received (step S512: Yes), then the control section 11 newly writes the received entry button information to the information storage section 13 (step S522).

[0219] Then, the control section 11 determines whether or not the information content has been received by the wireless communication section 12 from the information providing server 30 (step S523).

[0220] If it is determined that the information content has not been received (step S523: No), then the process proceeds to the processing of step S521.

[0221] If it is determined that the information content has been received (step S523: Yes), then the information storage section 13 stores the received information content. Then, the display section 14 displays the received information content (step S524).

[0222] As described above, according to this embodiment, the following advantages are obtained in addition to the advantages of the embodiments 1 and 2.

[0223] If the mobile terminal 10 does not hold entry button information associated with a received SSID, it acquires not only information content associated with the SSID but also entry button information associated with the SSID from the information providing server 30.

[0224] Accordingly, when moving into the access point area where the above SSID was received and acquiring information content next time, the mobile terminal 10 can display entry button screen information on which information within the access point area is shown. Thus, the mobile terminal user can recognize the summary of information content available in the area before acquiring the information content.

[0225] Furthermore, the information providing server 30 can omit the processing of detecting an address of information content with a received SSID as a key.

[0226] Though the above processings in the embodiments 1 to 3 are performed by a computer program held by the mobile terminal 10, the wireless access points 20, 50 and 60, the information providing server 30, the network charging server 70 or the information provision charging server 80, the program may be recorded on a recording medium such as an optical recording medium, magnetic recording medium, magneto-optic recording medium and semiconductor and downloaded therefrom. Alternatively, the program may be loaded from external equipment connected via a predetermined network.

[0227] The above-described embodiments are only examples of preferred embodiments, and embodiments of the present invention are not limited thereto. Various variations of the embodiments are possible within a range not departing from the spirit of the present invention.

Claims

1. An information providing system comprising a mobile terminal, one or more wireless access points capable of communicating with the mobile terminal via a wireless communication network in respective communicable areas, and an information providing server connected to the wireless access points via a network;

the wireless access points having:

an acquisition request information delivery part for broadcast delivering acquisition request information for acquiring information content related to the respective communicable areas in the respective communicable areas; and the mobile terminal having:

a delivered information receiver for receiving the acquisition request information; a display for, when the acquisition request information is received by the acquisition request information receiving part, displaying screen information indicating that it is possible to acquire information content related to the communicable area in which the mobile terminal is currently located;

and
 an information acquisition request part for
 sending a request to acquire the informa-
 tion content to the information providing
 server when the screen information is dis- 5
 played; and
 the information providing server having:

an information content storage for
 storing one or more the information 10
 content;
 an information content extracting part
 for receiving the request to acquire the
 information content from the mobile 15
 terminal and extracting appropriate in-
 formation content from the one or
 more information content; and
 an information content sending part for
 sending the extracted information con- 20
 tent to the mobile terminal.

2. The information providing system according to
 claim 1, wherein

the acquisition request information delivery
 part delivers the acquisition request information in- 25
 cluding the screen information and address in-
 formation about information content related to a com-
 municable area in which the acquisition request in-
 formation is delivered; and

the information acquisition request part sends 30
 a request to acquire the information content stored
 at an address shown by the address information.

3. An information providing system comprising a mo- 35
 bile terminal, one or more wireless access points
 capable of communicating with the mobile terminal
 via a wireless communication network in respective
 communicable areas, and an information providing
 server connected to the wireless access points via
 a network; 40

the wireless access points having:

an identification information delivery part for
 broadcast delivering identification information 45
 for identifying the access point in the commu-
 nicable area of the access point; and
 the mobile terminal having:

an acquisition request information storage
 for storing one or more pieces of acquisi- 50
 tion request information for acquiring infor-
 mation content related to the respective
 communicable areas;
 an identification information receiver for re- 55
 ceiving the identification information;
 an acquisition request information extract-
 ing part for, when the identification informa-
 tion is received by the identification infor-

mation receiving part, extracting acquisi-
 tion request information for acquiring infor-
 mation content related to a communicable
 area identified by the identification informa-
 tion from the one or more pieces of acqui-
 sition request information;
 a display for displaying screen information
 indicating that it is possible to acquire in-
 formation content related to the communi-
 cable area in which the mobile terminal is
 currently located, the screen information
 being included in the extracted acquisition
 request information; and
 an information acquisition request part for
 sending a request to acquire the informa-
 tion content to the information providing
 server when the screen information is dis-
 played; and
 the information providing server having:

information content storage for storing
 one or more pieces of the information
 content;

an information content extracting part
 for receiving the request to acquire the
 information content from the mobile
 terminal and extracting appropriate in-
 formation content from the one or
 more pieces of information content;
 and

an information content sending part for
 sending the extracted information con-
 tent to the mobile terminal.

4. The information providing system according to
 claim 3, wherein

the acquisition request information storage
 stores the acquisition request information including
 the address information about information content
 related to a communicable area in which the acqui-
 sition request information is delivered; and

the information acquisition request part sends
 a request to acquire the information content stored
 at an address shown by the address information. 45

5. The information providing system according to
 claim 3, wherein

when the acquisition request information for
 acquiring information content related to a commu-
 nicable area identified by the identification informa-
 tion received by the identification informa-
 tion receiving part is not stored in the acquisition request
 information storage, the display displays screen in-
 formation indicating that it is possible to acquire the
 information content;

the acquisition request part sends the re-
 ceived identification information to the information
 providing server;

- the information content storage stores the one or more pieces of information content in association with the identification information; and
the information content extracting part receives the identification information from the mobile terminal and extracts the information content associated with the received identification information.
6. The information providing system according to claim 5, wherein
the information providing server has:
a server information storage for storing the one or more pieces of acquisition request information in association with the identification information;
a server information extracting part for extracting the acquisition request information associated with the identification information received from the mobile terminal; and
a server information sending part for sending the extracted acquisition request information to the mobile terminal; and
the acquisition request information storage newly stores the acquisition request information sent from the information providing server.
7. The information providing system according to any one of claims 1 to 6, the information providing system further comprising an information provision charging server connected to the information providing server; wherein
the information providing server has:
a sending history storage for storing sending history of the information content sent by the information content sending part; and
a sending history sending part for sending the stored sending history to the information provision charging server; and
the information provision charging server has:
service use fee calculator for, when receiving the sending history from the information providing server, calculating an information delivery service use fee to be paid from a business entity developing business related to the information content to a business entity managing the information providing server, based on the received sending history.
8. The information providing system according to claim 7, wherein the service use fee calculator calculates the information delivery service use fee based on information indicating the number of times the information content has been sent by the information content sending part, the information being included in the sending history.
9. The information providing system according to claim 7 or 8, wherein the service use fee calculator calculates the information delivery service use fee based on the data amount of the information content.
10. The information providing system according to any one of claims 1 to 9, the information providing system further comprising a network charging server connected to the network; wherein
the network charging server has network use fee calculator for calculating a fee for use of the network to be paid from a user of the mobile terminal and the business entity managing the information providing server to a business entity managing the network, based on information indicating use condition of the network by the mobile terminal and the information providing server.
11. A mobile terminal comprising:
a delivered information receiver for, in a communicable area enabling communication with a wireless access point, receiving acquisition request information for acquiring information content related to the communicable area;
a display for extracting screen information indicating that it is possible to acquire the information content from the received acquisition request information and displaying the screen information; and
an information acquisition request part for extracting address information about the information content from the received acquisition request information and sending a request to acquire the information content to an address shown by the address information when the screen information is displayed.
12. A mobile terminal comprising:
identification information receiver for, in a communicable area enabling communication with a wireless access point, receiving identification information for identifying the wireless access point;
an acquisition request information storage for storing one or more pieces of acquisition request information for acquiring information content related to the communicable area;
an acquisition request information extracting part for, when the identification information is received by the identification information receiving part, extracting acquisition request information for acquiring information content related to a communicable area identified by the

identification information from the one or more pieces of acquisition request information; a display for extracting screen information indicating that it is possible to acquire the information content from the extracted acquisition request information and displaying the screen information; and an information acquisition request part for extracting address information about the information content from the extracted acquisition request information and sending a request to acquire the information content to an address shown by the address information when the screen information is displayed.

13. A wireless access point for performing wireless communication with a mobile terminal in a communicable area, the wireless access point broadcast delivering, within the communicable area, acquisition request information including screen information indicating that it is possible to acquire information content related to the communicable area and address information about the information content.

14. A charging server comprising:
 a sending history input part for inputting sending history of sending of information content related to a communicable area of a wireless access point to a mobile terminal performing wireless communication with the wireless access point; and
 a service use fee calculator for calculating an information delivery service use fee to be paid from a business entity developing business related to the information content to a business entity providing a service of sending the information content, based on the inputted sending history.

15. A charging server comprising:
 a use condition information input part for, when a mobile terminal requests acquisition of information content related to a communicable area of a wireless access point from equipment on the sending side of the information content and acquires the information content as a response to the request via a network, inputting information indicating condition of use of the network by the mobile terminal and the equipment on the sending side of the information content; and
 a network use fee calculator for calculating a fee for use of the network to be paid from a user of the mobile terminal and a business entity sending the information content to a business entity managing the network, based on the inputted network use condition information.

16. An information providing method, using a mobile terminal, one or more wireless access points capable of communicating with the mobile terminal via a wireless communication network in respective communicable areas, and an information providing server connected to the wireless access points via a network and comprising:

an acquisition request information delivery step of the wireless access point broadcast delivering acquisition request information for acquiring information content related to the respective communicable areas in the respective communicable areas; and
 a delivered information receiving step of the mobile terminal receiving the acquisition request information;
 a display step of, when receiving the acquisition request information, the mobile terminal displaying screen information indicating that it is possible to acquire information content related to the communicable area in which the mobile terminal is currently located;
 an information acquisition request step of the mobile terminal sending a request to acquire the information content to the information providing server when the screen information is displayed;
 an information content extracting step of the information providing server receiving the request to acquire the information content from the mobile terminal and extracting appropriate information content from the one or more pieces of information content stored in the server; and
 an information content sending step of the information providing server sending the extracted information content to the mobile terminal.

17. An information providing method, using a mobile terminal, one or more wireless access points capable of communicating with the mobile terminal via a wireless communication network in respective communicable areas, and an information providing server connected to the wireless access points via a network and comprising:

an identification information delivery step of the respective wireless access points broadcast delivering identification information for identifying the respective access points in the respective communicable areas; and
 an acquisition request information storage step of the mobile terminal storing one or more pieces of acquisition request information for acquiring information content related the respective communicable areas;
 an identification information receiving step of

the mobile terminal receiving the identification information;

an acquisition request information extracting step of, when receiving the identification information, the mobile terminal extracting acquisition request information for acquiring information content related to a communicable area identified by the identification information from the information content related to the one or more communicable areas, the information content being stored in the mobile terminal;

a display step of the mobile terminal displaying screen information indicating that it is possible to acquire information content related to the communicable area in which the mobile terminal is currently located, the screen information being included in the extracted acquisition request information;

an information acquisition request step of the mobile terminal sending a request to acquire the information content to the information providing server when the screen information is displayed;

an information content extracting step of the information providing server receiving the request to acquire the information content from the mobile terminal and extracting appropriate information content from the one or more pieces of information content stored in the server;

and

an information content sending step of the information providing server sending the extracted information content to the mobile terminal.

18. The information providing method according to claim 17, wherein

at the display step, if the acquisition request information for acquiring information content related to a communicable area identified by the identification information received by the identification information receiver is not stored in the mobile terminal, the mobile terminal displays screen information indicating that it is possible to acquire the information content;

at the acquisition request step, the mobile terminal sends the received identification information to the information providing server; and

at the information content extracting step, the information providing server receives the identification information from the mobile terminal and extracts the information content associated with the received identification information from the one or more pieces of information content stored in the server in association with the identification information.

19. The information providing method according to claim 18, the information providing method comprising:

prising:

a server information extracting step of the information providing server extracting the acquisition request information associated with the identification information received from the mobile terminal from the one or more pieces of acquisition request information stored in the server in association with the identification information;

a server information sending step of the information providing server sending the extracted acquisition request information to the mobile terminal; and

an acquisition request information storage step of the mobile terminal newly storing the acquisition request information sent from the information providing server in the mobile terminal.

20. The information providing method according to any one of claims 16 to 19, the information providing method comprising:

a sending history storage step of the information providing server storing sending history of the information content at the information content sending step in the information providing server;

a sending history sending step of the information providing server sending the stored sending history to an information provision charging server connected to the information providing server; and

a service use fee calculation step of, when receiving the sending history from the information providing server, the information providing charging server calculating an information delivery service use fee to be paid from a business entity developing business related to the information content to a business entity managing the information providing server, based on the received sending history.

21. The information providing method according to claim 20, wherein, at the service use fee calculation step, the information provision charging server calculates the information delivery service use fee based on information indicating the number of times the information content has been sent at the information content sending step, the information being included in the sending history.

22. The information providing method according to claim 20 or 21, wherein, at the service use fee calculation step, the information provision charging server calculates the information delivery service use fee based on the data amount of the information content.

23. The information providing method according to any one of claims 16 to 22, the information providing method comprising a network use fee calculation step of the network charging server connected to the network calculating a fee for use of the network to be paid from a user of the mobile terminal and the business entity managing the information providing server to a business entity managing the network, based on information indicating use condition of the network by the mobile terminal and the information providing server.

5

10

15

20

25

30

35

40

45

50

55

21

FIG.1

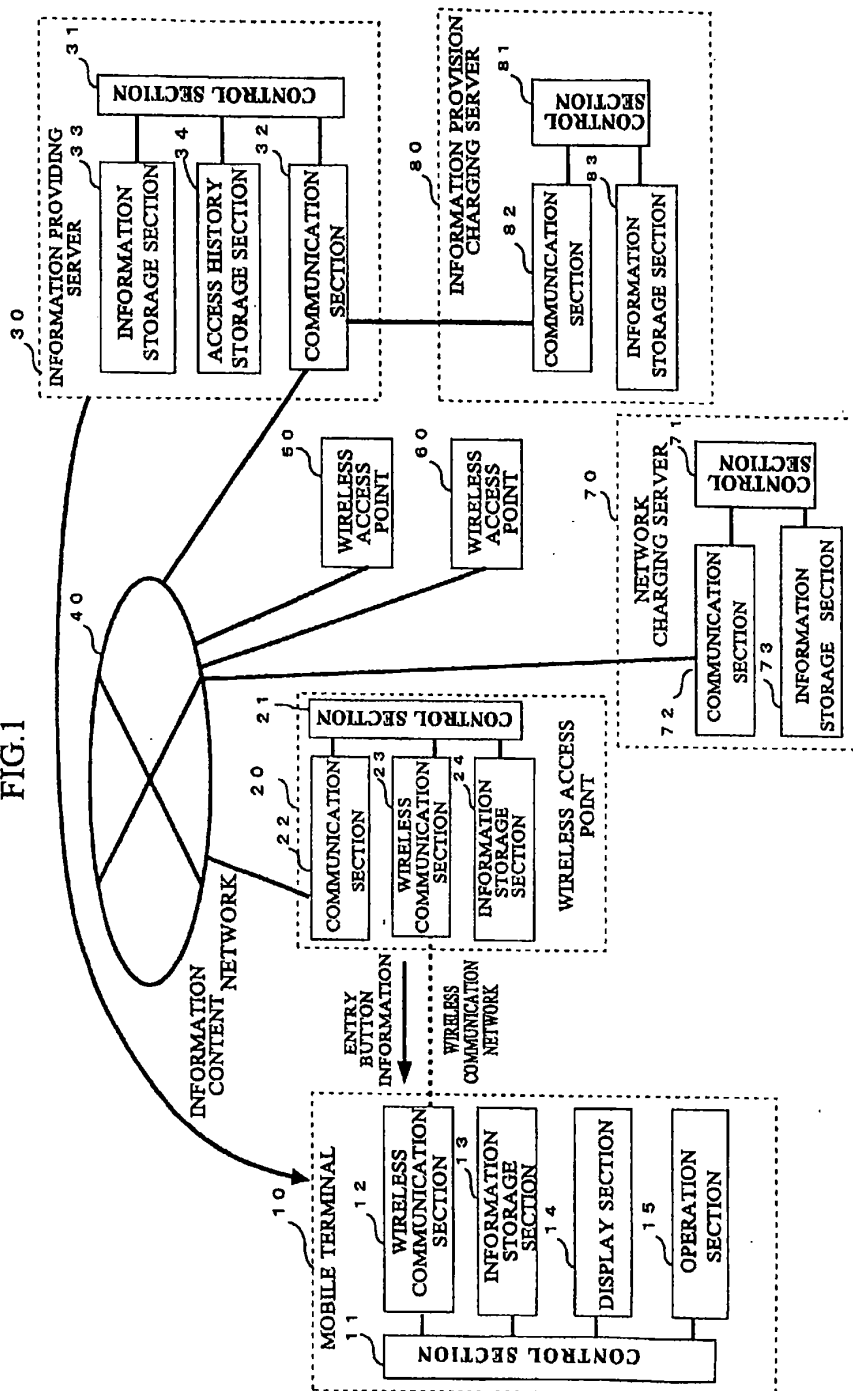
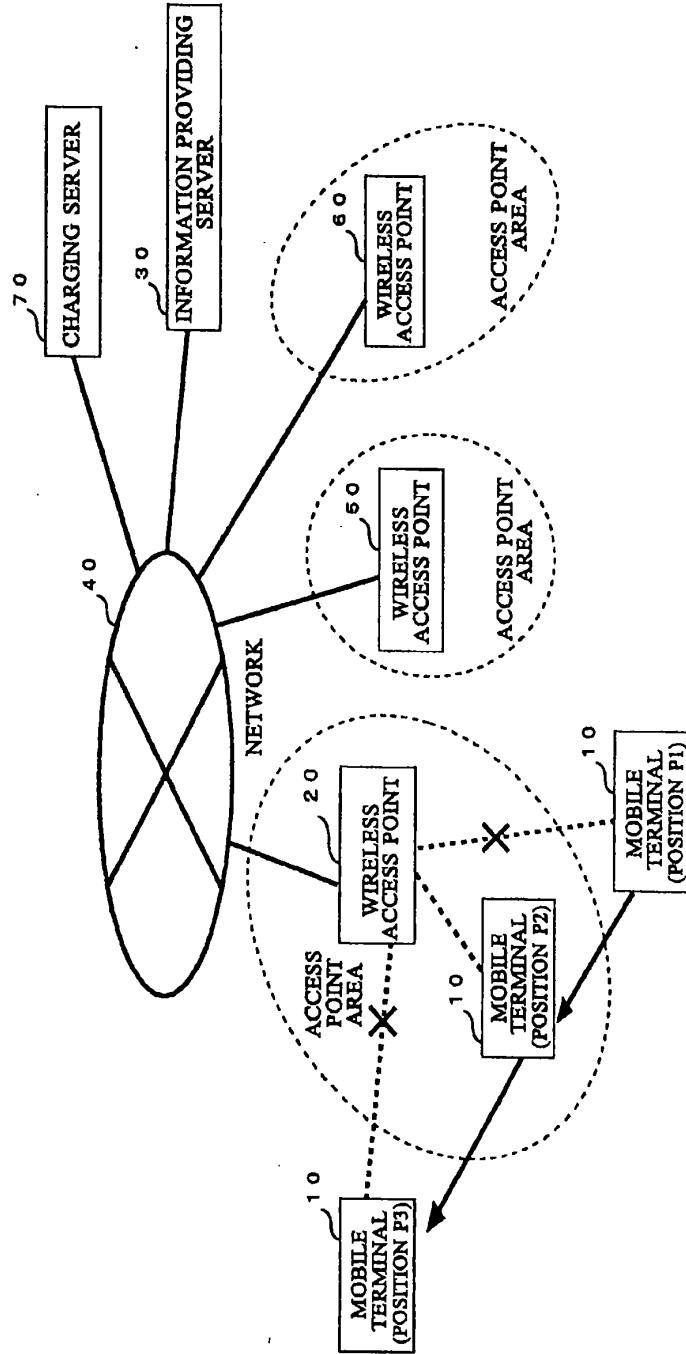

FIG.2



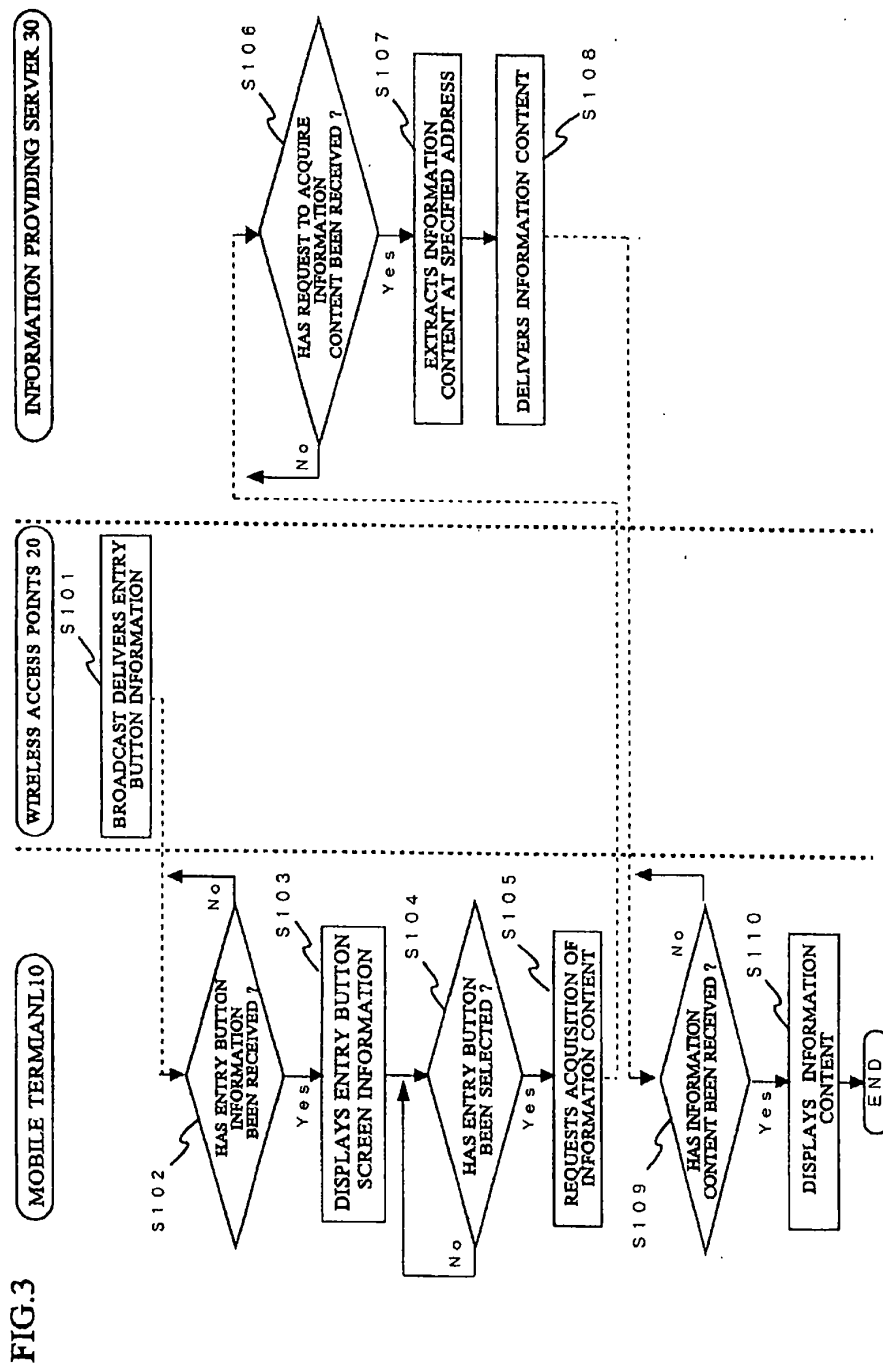

FIG. 4

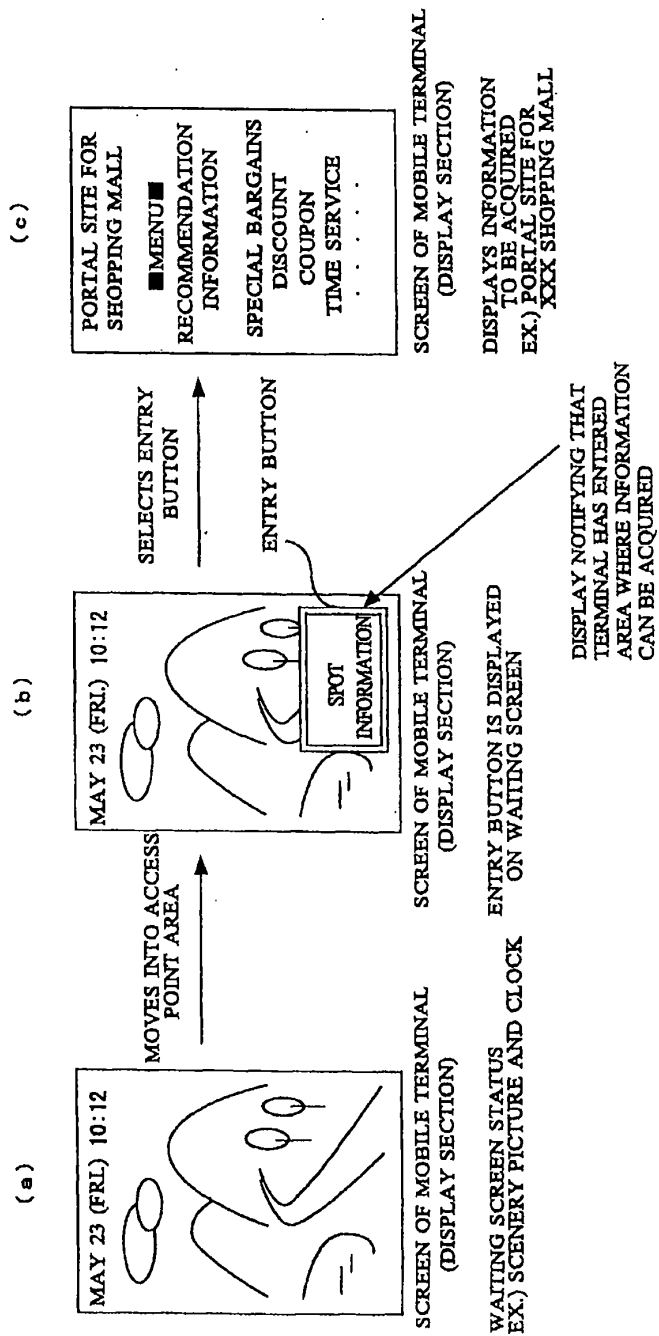

FIG.5

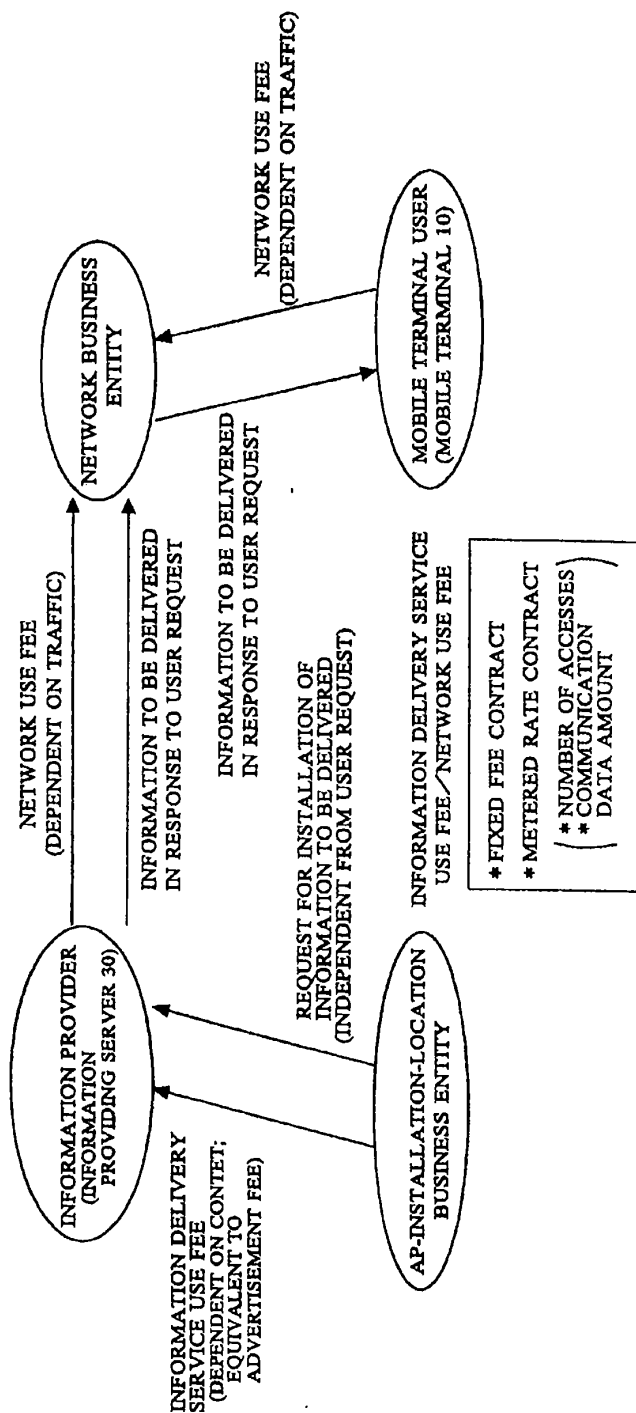

FIG.6

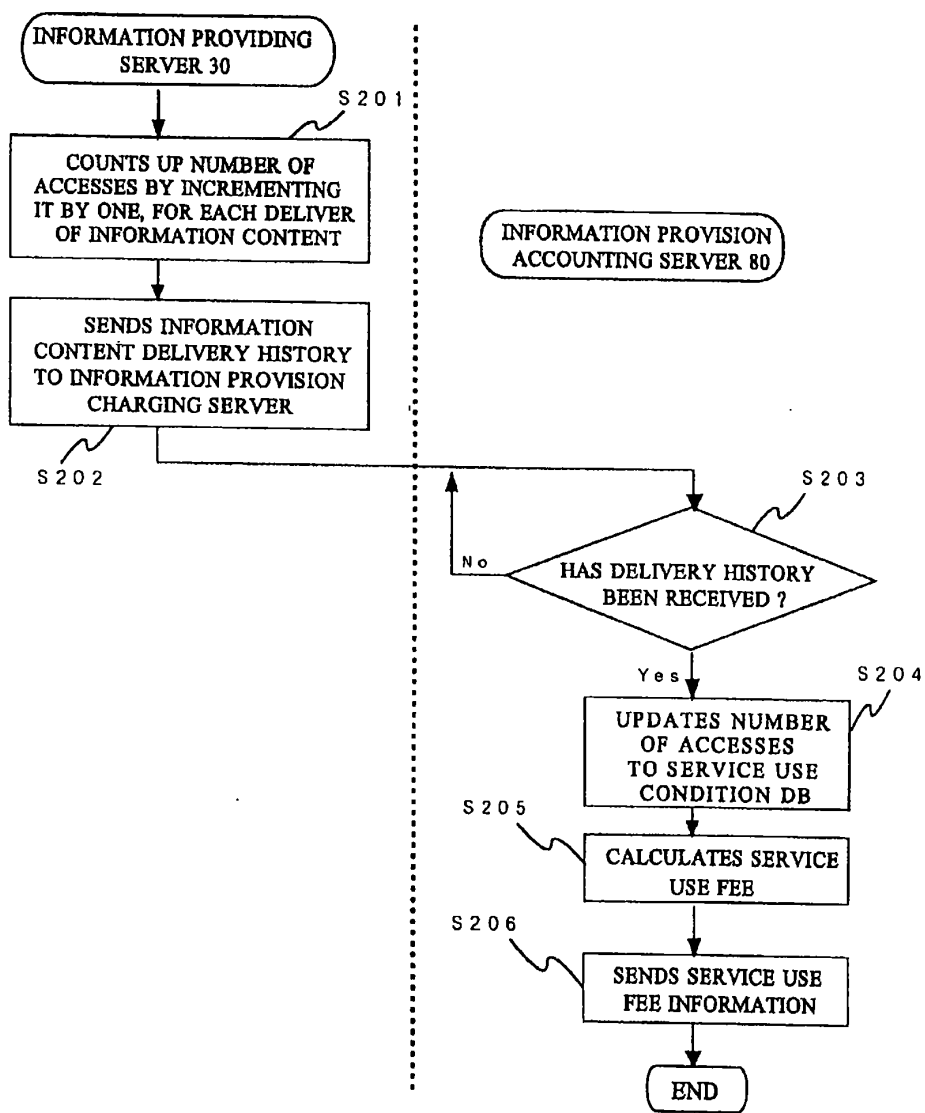

FIG.7

INFORMATION CONTENT ID	BUSINESS ENTITY ID	DATA AMOUNT	NUMBER OF ACCESSES
00001	0001	1Kbyte	121
00002	0002	2Kbyte	38
00003	0002	1.5Kbyte	5
00005	0005	5Kbyte	29
⋮	⋮	⋮	⋮
⋮	⋮	⋮	⋮
⋮	⋮	⋮	⋮

FIG.8

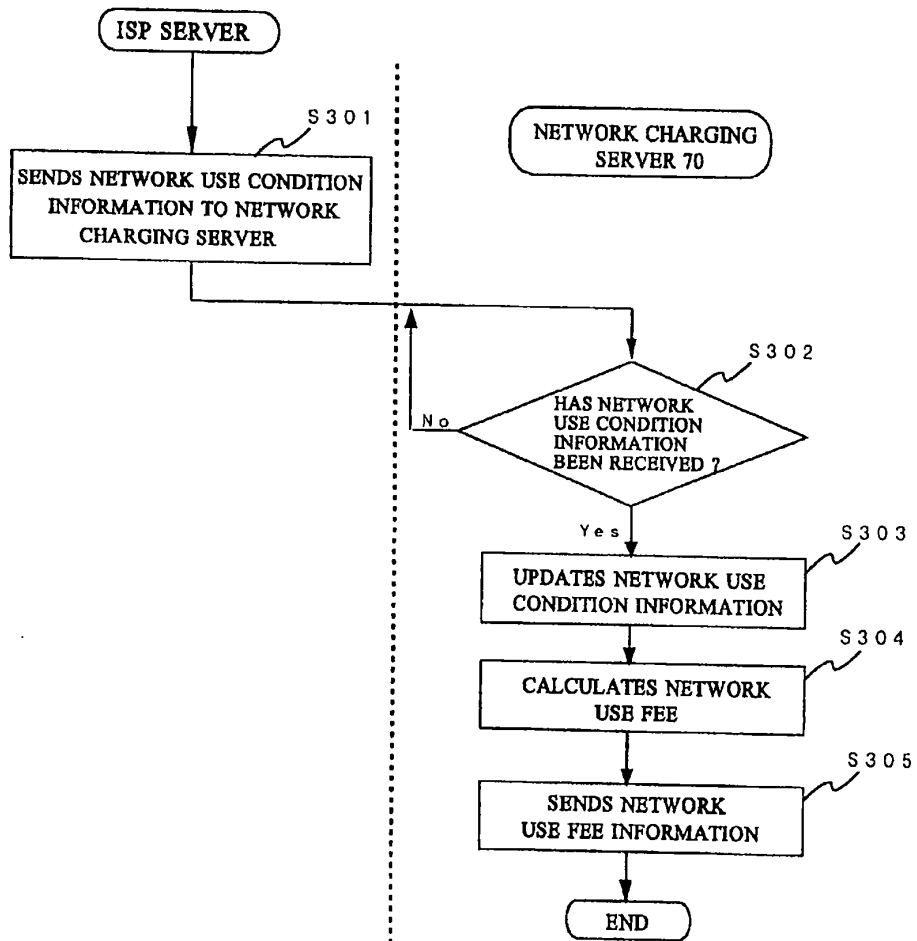

FIG. 9

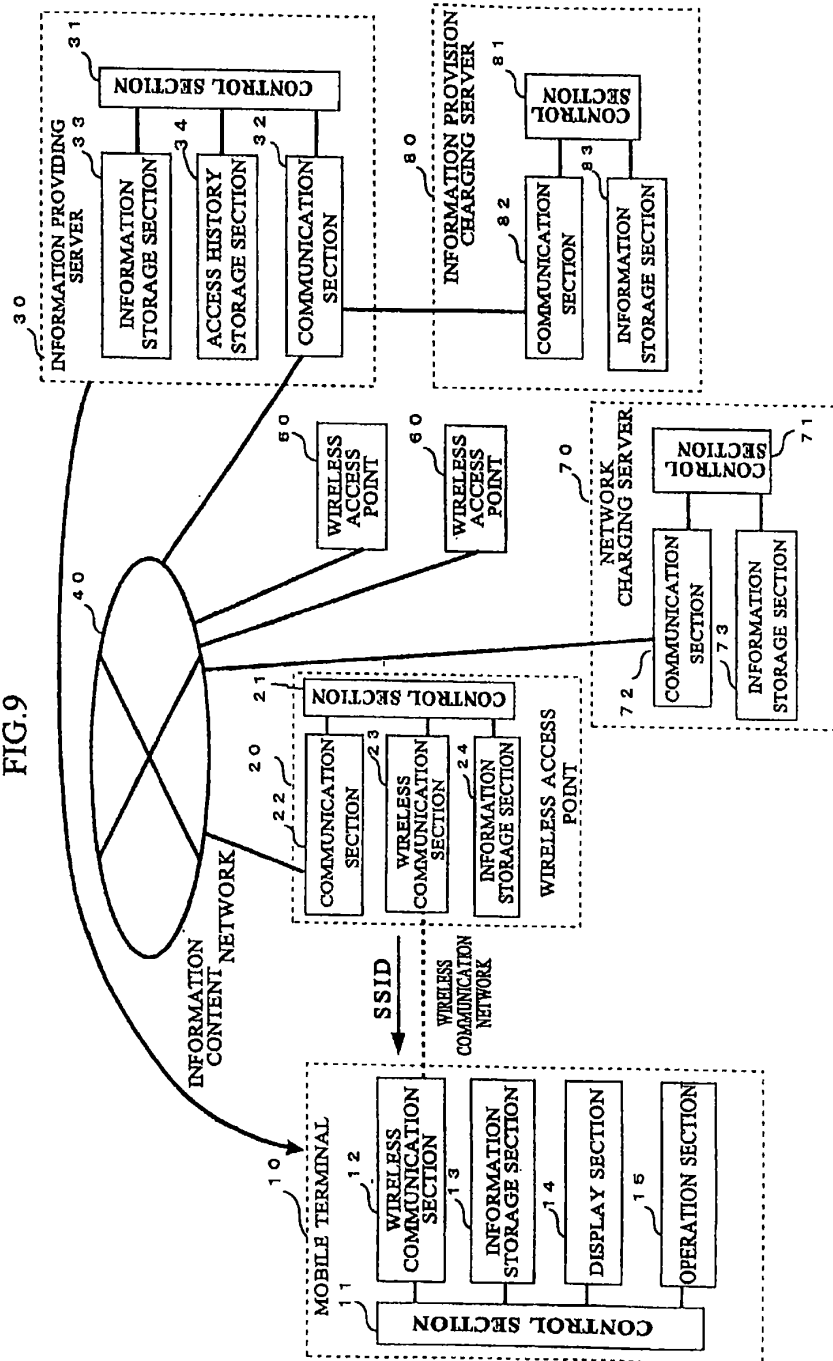

FIG.10

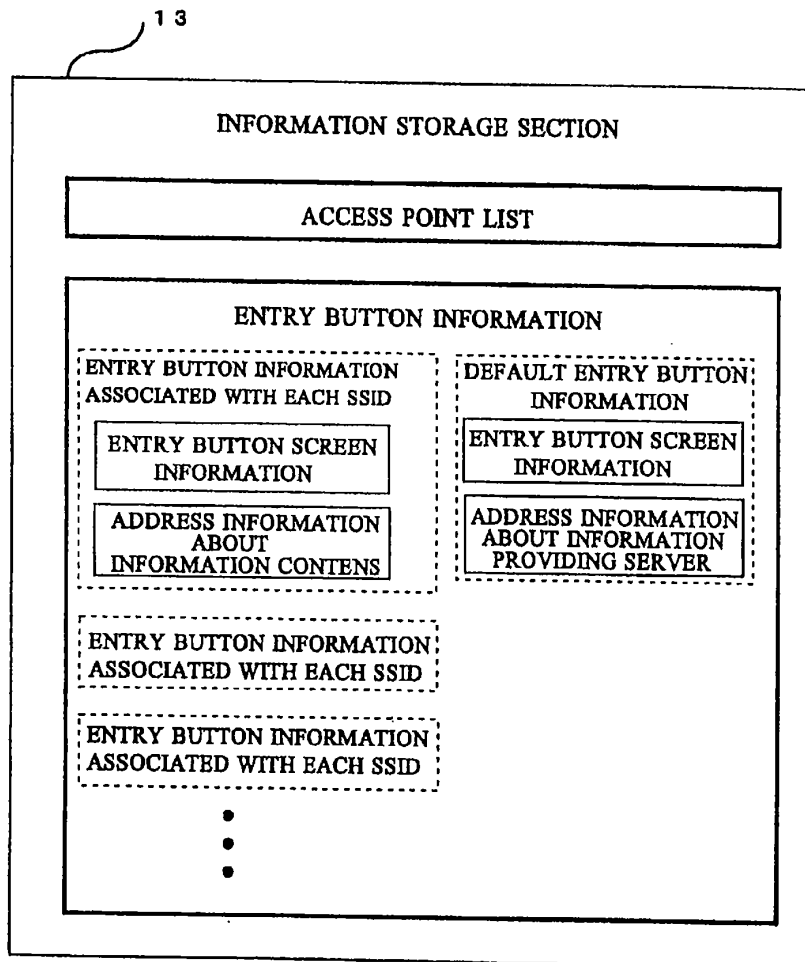

FIG.11

ACCESS POINT LIST

xxxxxxx1
xxxxxxx3
xxxxxxx4
xxxxxxx7
:
:

FIG.12

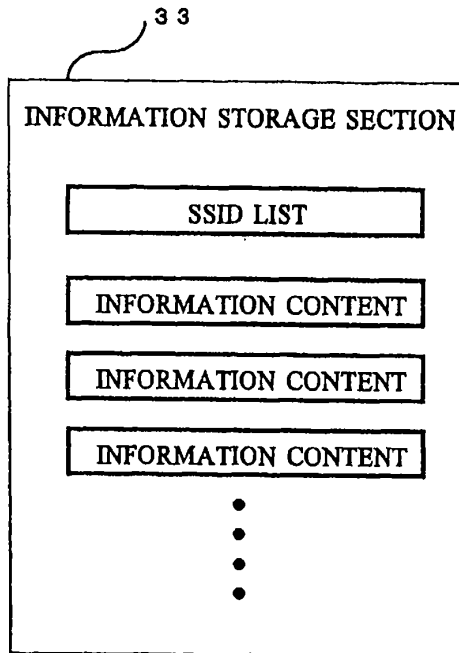

FIG.13

SSID LIST

SSID	ADDRESS OF INFORMATION CONTENT
xxxxxxx1	aaa/bb/11
xxxxxxx2	aaa/bb/12
xxxxxxx3	aaa/bb/13
xxxxxxx4	aaa/bb/20
xxxxxxx5	aaa/bb/22
xxxxxxx6	aaa/cc/11
:	:
:	:
:	:

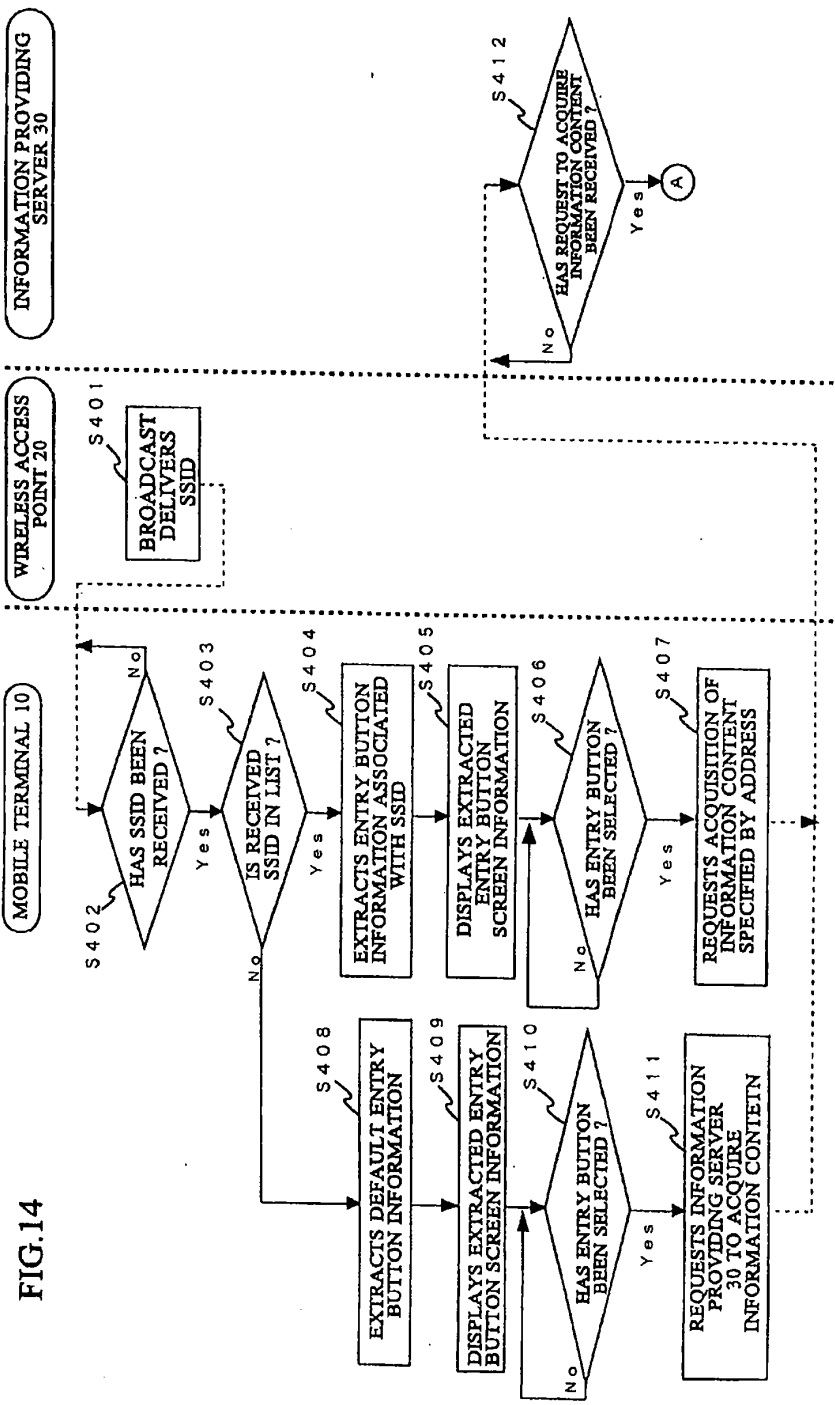

FIG. 14

FIG.15

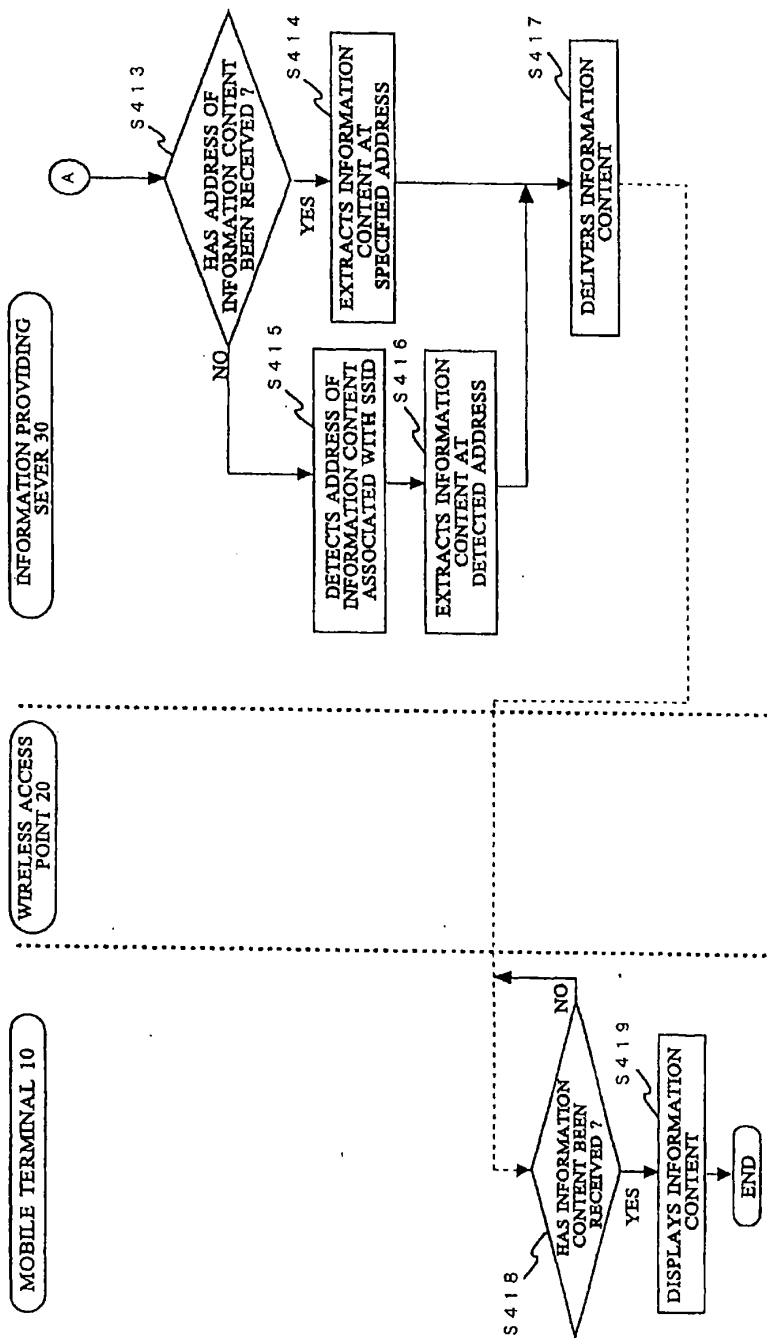

FIG.16

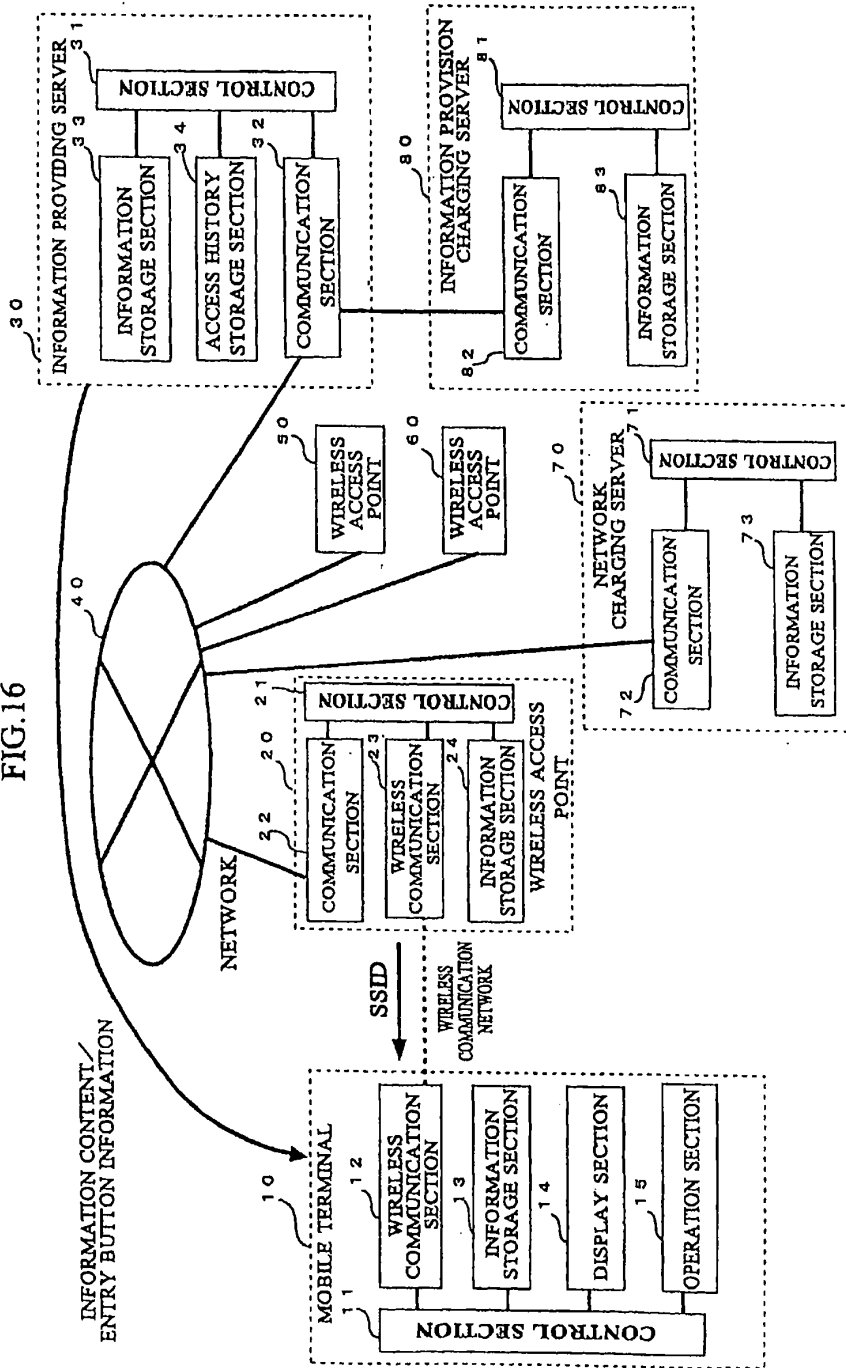

FIG.17

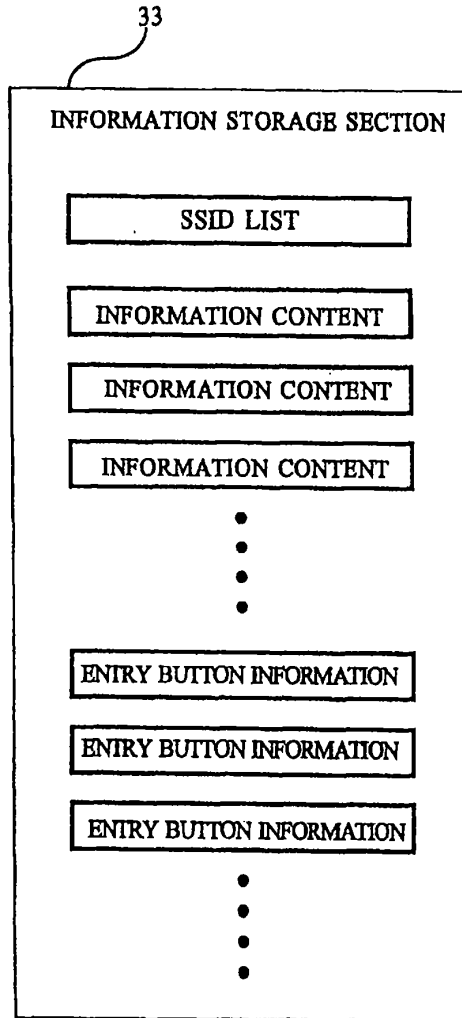

FIG.18

SSID LIST

SSID	ADDRESS OF INFORMATION CONTENT	ADDRESS OF ENTRY BUTTON INFORMATION
xxxxxxx1	aaa/bb/11	aaa/aa/30
xxxxxxx2	aaa/bb/12	aaa/aa/31
xxxxxxx3	aaa/bb/13	aaa/aa/39
xxxxxxx4	aaa/bb/20	aaa/dd/30
xxxxxxx5	aaa/bb/22	aaa/dd/13
xxxxxxx6	aaa/cc/11	aaa/dd/11
⋮	⋮	⋮
⋮	⋮	⋮
⋮	⋮	⋮

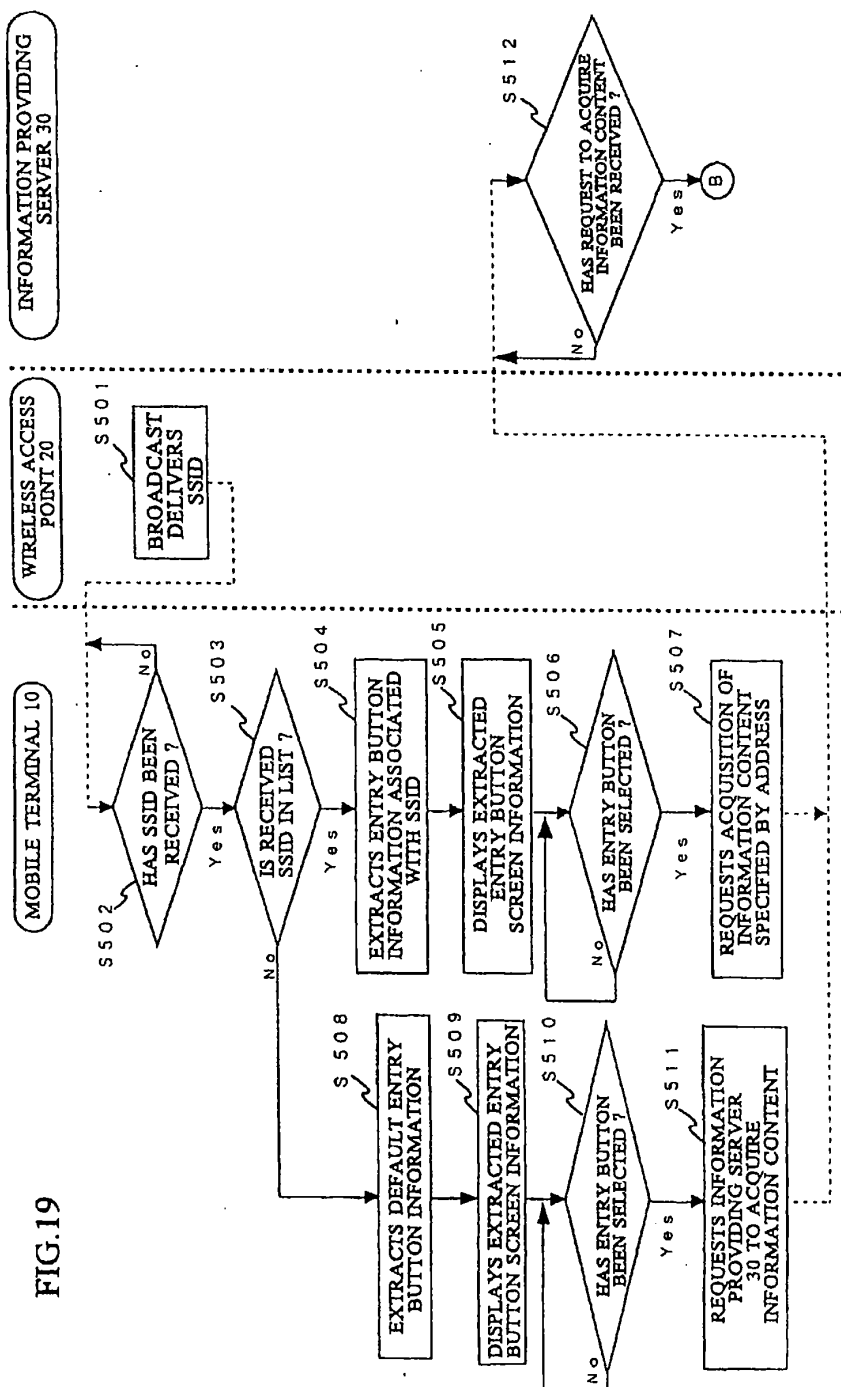

FIG. 19

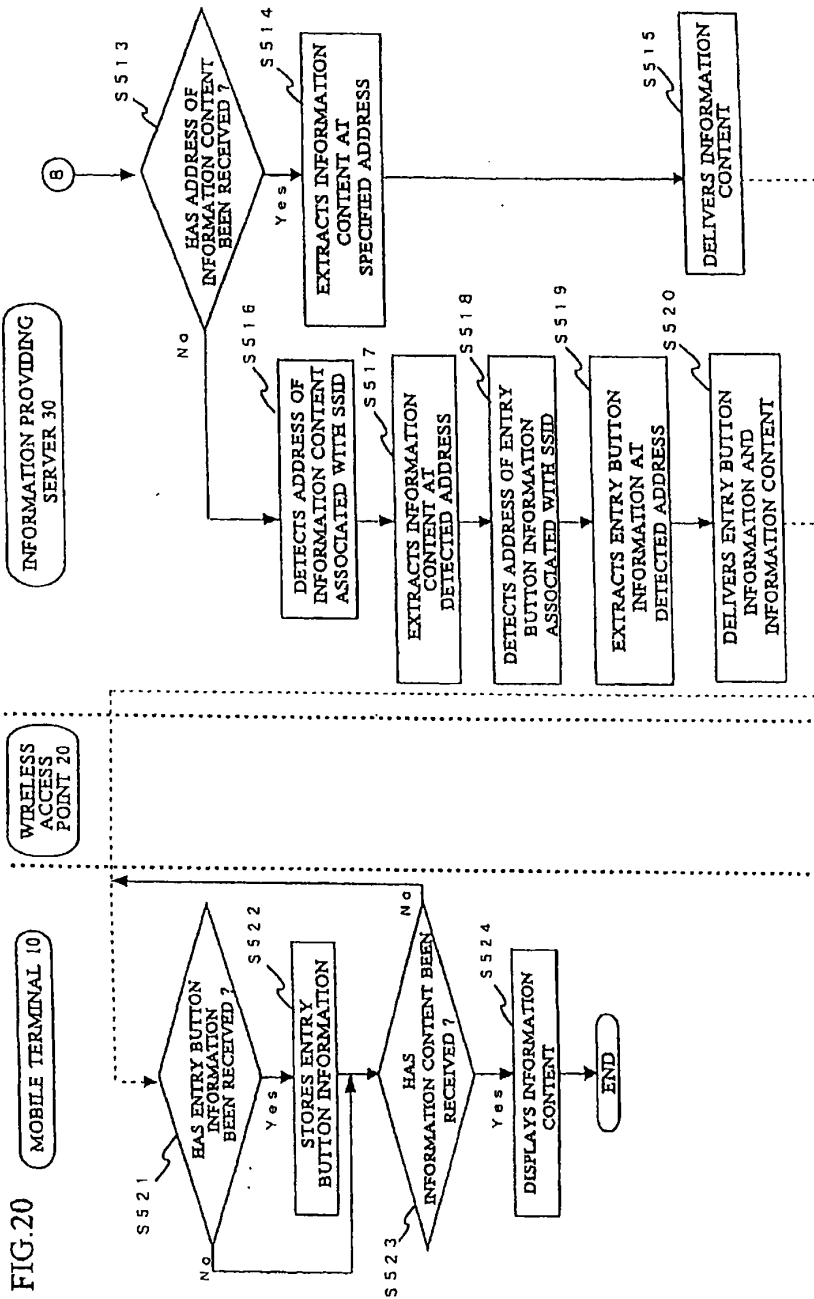

FIG. 20

PATENT COOPERATION TREATY

M

From the INTERNATIONAL SEARCHING AUTHORITY

To:
 BRYAN K. WHELOCK
 HARNESS, DICKEY & PIERCE, P.C.
 7700 BONHOMME AVENUE, SUITE 400
 ST. LOUIS, MO 63105

RECEIVED
 JUL 24 2006
 HARNESS, DICKEY & PIERCE
 ST. LOUIS, MISSOURI

PCT

NOTIFICATION OF TRANSMITTAL OF
 THE INTERNATIONAL SEARCH REPORT AND
 THE WRITTEN OPINION OF THE INTERNATIONAL
 SEARCHING AUTHORITY, OR THE DECLARATION
 (PCT Rule 44.1)

7362-000002/WO/POA

Date of mailing
 (day/month/year) 17 JUL 2006

Applicant's or agent's file reference 7362-000002/WO/POA	FOR FURTHER ACTION See paragraphs 1 and 4 below
International application No. PCT/US05/04897	International filing date (day/month/year) 14 February 2005 (14.02.2005)
Applicant WEISER, DOUGLAS D	

- The applicant is hereby notified that the international search report and the written opinion of the International Searching Authority have been established and are transmitted herewith.
Filing of amendments and statement under Article 19:
 The applicant is entitled, if he so wishes, to amend the claims of the international application (see Rule 46):
When? The time limit for filing such amendments is normally two months from the date of transmittal of the international search report.
Where? Directly to the International Bureau of WIPO, 34 chemin des Colombettes
 1211 Geneva 20, Switzerland, Facsimile No.: (41-22) 338.82.70.
For more detailed instructions, see the notes on the accompanying sheet.
- The applicant is hereby notified that no international search report will be established and that the declaration under Article 17(2)(a) to that effect and the written opinion of the International Searching Authority are transmitted herewith.
- With regard to the protest against payment of (an) additional fee(s) under Rule 40.2, the applicant is notified that:
 - the protest together with the decision thereon has been transmitted to the International Bureau together with the applicant's request to forward the texts of both the protest and the decision thereon to the designated Offices.
 - no decision has been made yet on the protest; the applicant will be notified as soon as a decision is made.
- 4. Reminders**
 Shortly after the expiration of **18 months** from the priority date, the international application will be published by the International Bureau. If the applicant wishes to avoid or postpone publication, a notice of withdrawal of the international application, or of the priority claim, must reach the International Bureau as provided in Rules 90bis.1 and 90bis.3, respectively, before the completion of the technical preparations for international publication.
 The applicant may submit comments on an informal basis on the written opinion of the International Searching Authority to the International Bureau. The International Bureau will send a copy of such comments to all designated Offices unless an international preliminary examination report has been or is to be established. These comments would also be made available to the public but not before the expiration of 30 months from the priority date.
 Within **19 months** from the priority date, but only in respect of some designated Offices, a demand for international preliminary examination must be filed if the applicant wishes to postpone the entry into the national phase **until 30 months** from the priority date (in some Offices even later); otherwise, the applicant must, within **20 months** from the priority date, perform the prescribed acts for entry into the national phase before those designated Offices.
 In respect of other designated Offices, the time limit of **30 months** (or later) will apply even if no demand is filed within 19 months.
 See the Annex to Form PCT/IB/301 and, for details about the applicable time limits, Office by Office, see the *PCT Applicant's Guide*, Volume II, National Chapters and the WIPO Internet site.

Name and mailing address of the ISA/ US Mail Stop PCT, Attn: ISA/US Commissioner for Patents P.O. Box 1450 Alexandria, Virginia 22313-1450 Facsimile No. (571) 273-3201	Authorized officer  Zarni Maung Telephone No. (571) 272-1400
--	---

Form PCT/ISA/220 (January 2004)

(See notes on accompanying sheet)

PATENT COOPERATION TREATY

PCT

INTERNATIONAL SEARCH REPORT

(PCT Article 18 and Rules 43 and 44)

Applicant's or agent's file reference 7362-000002/WO/POA	FOR FURTHER ACTION see Form PCT/ISA/220 as well as, where applicable, item 5 below.	
International application No. PCT/US05/04897	International filing date (<i>day/month/year</i>) 14 February 2005 (14.02.2005)	(Earliest) Priority Date (<i>day/month/year</i>) 13 February 2004 (13.02.2004)
Applicant WEISER, DOUGLAS D		

This international search report has been prepared by this International Searching Authority and is transmitted to the applicant according to Article 18. A copy is being transmitted to the International Bureau.

This international search report consists of a total of 9 sheets.

It is also accompanied by a copy of each prior art document cited in this report.

1. Basis of the Report

a. With regard to the language, the international search was carried out on the basis of:

- the international application in the language in which it was filed.
 a translation of the international application into _____, which is the language of a translation furnished for the purposes of international search (Rules 12.3(a) and 23.1(b))

b. With regard to any nucleotide and/or amino acid sequence disclosed in the international application, see Box No. I.

2. Certain claims were found unsearchable (See Box No. II)

3. Unity of invention is lacking (See Box No. III)

4. With regard to the title,

- the text is approved as submitted by the applicant.
 the text has been established by this Authority to read as follows:

5. With regard to the abstract,

- the text is approved as submitted by the applicant.
 the text has been established, according to Rule 38.2(b), by this Authority as it appears in Box No. IV. The applicant may, within one month from the date of mailing of this international search report, submit comments to this Authority.

6. With regard to the drawings,

- a. the figure of the drawings to be published with the abstract is Figure No. _____
 as suggested by the applicant.
 as selected by this Authority, because the applicant failed to suggest a figure.
 as selected by this Authority, because this figure better characterizes the invention.
- b. none of the figures is to be published with the abstract.

Form PCT/ISA/210 (first sheet) (April 2005)

INTERNATIONAL SEARCH REPORT

International application No.

PCT/US05/04897

A. CLASSIFICATION OF SUBJECT MATTER IPC: G06E 15/16 USPC: 709/206 According to International Patent Classification (IPC) or to both national classification and IPC		
B. FIELDS SEARCHED Minimum documentation searched (classification system followed by classification symbols) U.S. : 709/206 Documentation searched other than minimum documentation to the extent that such documents are included in the fields searched Electronic data base consulted during the international search (name of data base and, where practicable, search terms used)		
C. DOCUMENTS CONSIDERED TO BE RELEVANT		
Category *	Citation of document, with indication, where appropriate, of the relevant passages	Relevant to claim No.
Y	US 2002/0107016 A1 (HANLEY) 08 August 2002 (08.08.2002), figure 1, paragraphs 0025-0030	1-30
Y	US 6,219,696 B1 (WYNBLATT et al) 17 April 2001 (17.04.2001), column 2-4.	1-30
Y	US 6,240,360 B1 (PHELAN) 29 May 2001 (29.05.2001), figures 1-3, column 4-7	3, 7, 12, 14, 17-18, 24-25, 27-29
<input type="checkbox"/> Further documents are listed in the continuation of Box C. <input type="checkbox"/> See patent family annex.		
* Special categories of cited documents:		
"A"	document defining the general state of the art which is not considered to be of particular relevance	"T" later document published after the international filing date or priority date and not in conflict with the application but cited to understand the principle or theory underlying the invention
"E"	earlier application or patent published on or after the international filing date	"X" document of particular relevance; the claimed invention cannot be considered novel or cannot be considered to involve an inventive step when the document is taken alone
"L"	document which may throw doubts on priority claim(s) or which is cited to establish the publication date of another citation or other special reason (as specified)	"Y" document of particular relevance; the claimed invention cannot be considered to involve an inventive step when the document is combined with one or more other such documents, such combination being obvious to a person skilled in the art
"O"	document referring to an oral disclosure, use, exhibition or other means	"&" document member of the same patent family
"P"	document published prior to the international filing date but later than the priority date claimed	
Date of the actual completion of the international search 12 June 2006 (12.06.2006)	Date of mailing of the international search report 17 JUL 2006	
Name and mailing address of the ISA/US Mail Stop PCT, Attn: ISA/US Commissioner for Patents P.O. Box 1450 Alexandria, Virginia 22313-1450 Facsimile No. (571) 273-3201	Authorized officer <i>Zani Maung</i> Zani Maung Telephone No. (571) 272-1400	

Form PCT/ISA/210 (second sheet) (April 2005)

Electronic Patent Application Fee Transmittal

Application Number:					
Filing Date:					
Title of Invention:	BROADCAST ALERTING MESSAGE AGGREGATOR/GATEWAY SYSTEM AND METHOD				
First Named Inventor/Applicant Name:	Mark Andrew Wood				
Filer:	David L. Howard/Kim Adler				
Attorney Docket Number:	ENIT 9834C2				
Filed as Small Entity					
Utility under 35 USC 111(a) Filing Fees					
Description	Fee Code	Quantity	Amount	Sub-Total in USD(\$)	
Basic Filing:					
Utility filing Fee (Electronic filing)	4011	1	95	95	
Utility Search Fee	2111	1	310	310	
Utility Examination Fee	2311	1	125	125	
Pages:					
Claims:					
Miscellaneous-Filing:					
Petition:					
Patent-Appeals-and-Interference:					

Description	Fee Code	Quantity	Amount	Sub-Total in USD(\$)
Post-Allowance-and-Post-Issuance:				
Extension-of-Time:				
Miscellaneous:				
Total in USD (\$)				530

Electronic Acknowledgement Receipt

EFS ID:	11543717
Application Number:	13311448
International Application Number:	
Confirmation Number:	9039
Title of Invention:	BROADCAST ALERTING MESSAGE AGGREGATOR/GATEWAY SYSTEM AND METHOD
First Named Inventor/Applicant Name:	Mark Andrew Wood
Customer Number:	1688
Filer:	David L. Howard
Filer Authorized By:	
Attorney Docket Number:	ENIT 9834C2
Receipt Date:	05-DEC-2011
Filing Date:	
Time Stamp:	20:36:11
Application Type:	Utility under 35 USC 111(a)

Payment information:

Submitted with Payment	yes
Payment Type	Deposit Account
Payment was successfully received in RAM	\$530
RAM confirmation Number	4288
Deposit Account	162201
Authorized User	

File Listing:

Document Number	Document Description	File Name	File Size(Bytes)/ Message Digest	Multi Part /.zip	Pages (if appl.)
-----------------	----------------------	-----------	-------------------------------------	------------------	------------------

1	Application Data Sheet	ENIT_9834C2_ADS.pdf	1089690 348c2f513dc826a47a490b0ab84dbdd12490adcc	no	5
Warnings:					
Information:					
2		ENIT_9834C2_Broker_Con2_Pa ten_App.pdf	202363 4e98dc365fbf538694732d0d8e9636833264d42e	yes	47
Multipart Description/PDF files in .zip description					
Document Description		Start	End		
Specification		1	41		
Claims		42	46		
Abstract		47	47		
Warnings:					
Information:					
3	Drawings-only black and white line drawings	ENIT_9834C2_DRAWINGS.pdf	1171183 0c3857789fd50a771c40fc7e5127e1e8d531a0ac	no	11
Warnings:					
Information:					
4	Information Disclosure Statement (IDS) Form (SB08)	ENIT_9834C2_IDS.pdf	613777 c60061c8e98ebdcb9ca67e0bf3ab28f508283ebc	no	8
Warnings:					
Information:					
5	Foreign Reference	JP2000244427.pdf	691573 d173540e1bdfdb926f7727a019f29a2d620e3323	no	11
Warnings:					
Information:					
6	Foreign Reference	JP10336127.pdf	174436 9ecaa27987b15d51eaba20465816df251461c23	no	4
Warnings:					
Information:					
7	Foreign Reference	JP441719.pdf	547465 834265d9efe0a64fb2da3fd82676b0ff231e33f5	no	15
Warnings:					
Information:					

8	Foreign Reference	JP09098140.pdf	105542	no	3
			6e146bd08952dfadec1e8b91e1f8287164071148		
Warnings:					
Information:					
9	Foreign Reference	JP2000165826.pdf	111086	no	2
			31abb59b8ba2f86b2faf7e1ae5c830d704e5cad6		
Warnings:					
Information:					
10	Information Disclosure Statement (IDS) Form (SB08)	ENIT_9834C2_1A_IDS.pdf	615124	no	8
			9d0b3b377cf12db2ca8f563e00708b8e89c23726		
Warnings:					
Information:					
A U.S. Patent Number Citation or a U.S. Publication Number Citation is required in the Information Disclosure Statement (IDS) form for autoloading of data into USPTO systems. You may remove the form to add the required data in order to correct the Informational Message if you are citing U.S. References. If you chose not to include U.S. References, the image of the form will be processed and be made available within the Image File Wrapper (IFW) system. However, no data will be extracted from this form. Any additional data such as Foreign Patent Documents or Non Patent Literature will be manually reviewed and keyed into USPTO systems.					
11	Foreign Reference	JP441720.pdf	496619	no	11
			8110002f8faef10d8d57bab6c3163955f4017fd		
Warnings:					
Information:					
12	Foreign Reference	WO200030379.pdf	1000009	no	29
			619df3c7ee83878e149130ba4c0025c0956194c8		
Warnings:					
Information:					
13	Foreign Reference	WO199605678A1.pdf	656251	no	20
			6f423f923a8f9ca2b9dfa51353dfb134b24fd8bc		
Warnings:					
Information:					
14	Foreign Reference	WO1998049661.pdf	2309377	no	59
			4ffc875a7f9897736dfbe1e7e379e412e9db83b21		
Warnings:					
Information:					
15	Foreign Reference	WO200145061.pdf	1149531	no	37
			7d3dcd1bf993b81896d75000d9e4379710cac196		
Warnings:					
Information:					

16	Foreign Reference	WO200157724.pdf	3046342	no	76
			18d5beb5095e09cea3034176a2b0cacd795808d		
Warnings:					
Information:					
17	Foreign Reference	WO200189150.pdf	2773321	no	81
			da0c68c58c9e673e6ff654f0f18b4bec4527c00b		
Warnings:					
Information:					
18	Foreign Reference	WO2003071392.pdf	2862001	no	67
			0169bd9a77ce843d4c56cd13d6fb196ed72503ef		
Warnings:					
Information:					
19	Foreign Reference	WO2003077063.pdf	1153650	no	24
			2725b8f04a27c28f835b9288c6a080eac0cec43d		
Warnings:					
Information:					
20	Foreign Reference	WO2005079421.pdf	3081086	no	57
			513ff590b864bba83a01de050eb3bbe36cc2cab		
Warnings:					
Information:					
21	Foreign Reference	EP0915598.pdf	812482	no	17
			f66f426f8c524769821bfff1cd29072f3f6b10b0		
Warnings:					
Information:					
22	Foreign Reference	EP1032148.pdf	316838	no	6
			c9dd11f4e5d9df0bb3d3f37ec8e565df195486		
Warnings:					
Information:					
23	Foreign Reference	EP1071296.pdf	758509	no	13
			023c00ff06209fc4ee3af00f2ae8082bd156cf7		
Warnings:					
Information:					
24	Foreign Reference	EP1515512.pdf	1955384	no	41
			1aa096bfacc1db67bfbc52d7907238df65915c3		
Warnings:					
Information:					

25	Non Patent Literature	3rd_Generation.pdf	1978787 f9110a3b425aec6524edbe060880629ab0522640	no	42
Warnings:					
Information:					
26	Non Patent Literature	Bharat_Sanchar_Nigan_Limited.pdf	1331569 d2077a30a74721dd4875fd9c3eec61197a41950	no	21
Warnings:					
Information:					
27	Non Patent Literature	British_Parliament_Debates_CellAlert.pdf	292347 c8a22ba65f5e32ab1aacfc539959ee653f896434f	no	5
Warnings:					
Information:					
28	Non Patent Literature	Canadian_Contract_No5007441.pdf	2583996 6ee47ad69adf1613ee24065b6e1204c02aa96bc7	no	42
Warnings:					
Information:					
29	Non Patent Literature	Canadians_want_Emergency.pdf	41555 c3593024dd449be1a8b5c09d788a2c070503883e	no	1
Warnings:					
Information:					
30	Non Patent Literature	CEASA_Cell_Alert_System_Via_Cell_Broadcast.pdf	819368 1ed0689cf92c9ba37fd27f49a8572a134f644a1	no	24
Warnings:					
Information:					
31	Non Patent Literature	CEASA_News_and_Events_News.pdf	131097 f77fe12060be800db5de743fc88d41007f715795	no	3
Warnings:					
Information:					
32	Non Patent Literature	CEASA_Text_Message_Broadcasts.pdf	181279 88c08804821e60da22ed31813e15bc7030bc7697	no	2
Warnings:					
Information:					
33	Non Patent Literature	CEASA_International_Public_Warnings.pdf	280345 5ec7b4bce29a8d2e283688be08ad47f064aa96571	no	7
Warnings:					
Information:					

34	Non Patent Literature	CEASA_International_Welcome.pdf	53546 f65f061a9253e2eff0475873911133390311eb10	no	1
Warnings:					
Information:					
35	Non Patent Literature	Cellular_Emergency_Alert_Services_Association.pdf	42428 8f3f3b1e248d086101fe6ac72a2849b2f3cae5dda	no	1
Warnings:					
Information:					
36	Non Patent Literature	Chinese_search_report.pdf	56909 cfe396cc38e505d199890fe7c847b7733592b3c1	no	1
Warnings:					
Information:					
37	Non Patent Literature	CSEC_Wireless_Implementation_and_Maintenance.pdf	259457 7a31a27ec1ca0d3f30d74c5ea9a770bbae534b3	no	6
Warnings:					
Information:					
38	Non Patent Literature	Deaf_Today_Disability_Group.pdf	119260 039bb3820ac5f5d82c5831d7307a678d0b1d813	no	3
Warnings:					
Information:					
39	Non Patent Literature	Engadget_Dutch_Testing_Geo_Targeted.pdf	525863 f479c0923c82d22315a1a950b4f739d459197265	no	7
Warnings:					
Information:					
40	Non Patent Literature	ETSI_TS_123_246_UMTS.pdf	795645 50847a6262210f5ae0d21b558c75eb9139ea9463	no	16
Warnings:					
Information:					
41	Non Patent Literature	Global_Amateur_Radio_Emergency_Communications.pdf	615153 6306e5dc0a6efdb14c8c9411851a5776bc438d9e	no	15
Warnings:					
Information:					
42	Non Patent Literature	International_Search_Report.pdf	110439 4c78e52f7836fcd7ac78c74486cd185b93efd1e1	no	3
Warnings:					
Information:					

43	Non Patent Literature	Intl_Telecommunication_Unio n_Cell_Broadcast.pdf	704385 34598960bc6391052e01d392513506d58e b83b95	no	19
Warnings:					
Information:					
44	Non Patent Literature	Messaging_Network_Bercut_Li mited_Broadcast.pdf	441990 5b3e29f2dc9817e0f295c8a421635470819 028e	no	9
Warnings:					
Information:					
45	Non Patent Literature	MobileIN_com_Perspective_Ce ll_Broadcasting.pdf	150152 8840c456205c2b35e3464abbfe74973bef dddc4	no	3
Warnings:					
Information:					
46	Non Patent Literature	MobileIN_com_Perspective_Hi story_and_Importance.pdf	159083 4e8fd2dc8f48920a5adc7e0a5ba3ac829a6 2880	no	3
Warnings:					
Information:					
47	Non Patent Literature	News_from_Senator_John_Ed wards.pdf	32218 d5a6d137bc91548ef3e73853bd5bc87ddb 810f3a	no	1
Warnings:					
Information:					
48	Non Patent Literature	Newsientist_com_Text_Messa ge_Broadcast_Public.pdf	181279 1f630f95208708974d85e254b7a82cf7af0f3 ecd	no	2
Warnings:					
Information:					
49	Non Patent Literature	OCG_EMTEL_Archives_Cell_Bro adcast_Public_Demonstration. pdf	137562 4015edc5cac09a04514ea291e045447a0ad dd6f	no	3
Warnings:					
Information:					
50	Non Patent Literature	RCR_Cell_Broadcast_Service_G ets_Second_Look.pdf	218744 4b9463d4facd187a929e39864d02237f588 05fe0	no	4
Warnings:					
Information:					
51	Non Patent Literature	Recommendation_12_WTDC_0 2_Istanbul_2002.pdf	45461 ba0bc8b211adff0dc38e576d23f1773604a 7c1b2	no	2
Warnings:					
Information:					

52	Non Patent Literature	SMS_News_Text_Message_Broadcasts_Could_Provide.pdf	112688 a9b1373027525460bb8f333ce8e2ee0de405b749	no	2
Warnings:					
Information:					
53	Non Patent Literature	Stanford_University_EE179_Introduction_to_Communications.pdf	590978 3d3e48ca4ae86699248abf081699d970a1c6a45c	no	22
Warnings:					
Information:					
54	Non Patent Literature	TeliaSonera_Mobile_Broadcast_Multicast_Service_MBMS.pdf	466543 356230ae6594acd4f6bb2a23793a17ea1bae3a49	no	12
Warnings:					
Information:					
55	Non Patent Literature	Text_message_warn_of_killer_flu_hot_spots.pdf	32319 09bdb2e36ab9a37ebd1ca09c293f683bfd1a1f9b	no	1
Warnings:					
Information:					
56	Non Patent Literature	The_Cellular_Emergency_alert_Services.pdf	20188 a08e362e9ab5680bc9471429bce1d1a205e2a558	no	1
Warnings:					
Information:					
57	Non Patent Literature	The_Wall_Street_Journal_Local_govts.pdf	164676 7276d3b651e458097479ee40233e9239bb51986e	no	2
Warnings:					
Information:					
58	Fee Worksheet (SB06)	fee-info.pdf	33169 50695177d186e95054c97d808cef46b32dcf3613	no	2
Warnings:					
Information:					
Total Files Size (in bytes):			41404117		

This Acknowledgement Receipt evidences receipt on the noted date by the USPTO of the indicated documents, characterized by the applicant, and including page counts, where applicable. It serves as evidence of receipt similar to a Post Card, as described in MPEP 503.

New Applications Under 35 U.S.C. 111

If a new application is being filed and the application includes the necessary components for a filing date (see 37 CFR 1.53(b)-(d) and MPEP 506), a Filing Receipt (37 CFR 1.54) will be issued in due course and the date shown on this Acknowledgement Receipt will establish the filing date of the application.

National Stage of an International Application under 35 U.S.C. 371

If a timely submission to enter the national stage of an international application is compliant with the conditions of 35 U.S.C. 371 and other applicable requirements a Form PCT/DO/EO/903 indicating acceptance of the application as a national stage submission under 35 U.S.C. 371 will be issued in addition to the Filing Receipt, in due course.

New International Application Filed with the USPTO as a Receiving Office

If a new international application is being filed and the international application includes the necessary components for an international filing date (see PCT Article 11 and MPEP 1810), a Notification of the International Application Number and of the International Filing Date (Form PCT/RO/105) will be issued in due course, subject to prescriptions concerning national security, and the date shown on this Acknowledgement Receipt will establish the international filing date of the application.

Under the Paperwork Reduction Act of 1995, no persons are required to respond to a collection of information unless it contains a valid OMB control number.

Application Data Sheet 37 CFR 1.76	Attorney Docket Number	ENIT 9834C2
	Application Number	
Title of Invention	BROADCAST ALERTING MESSAGE AGGREGATOR/GATEWAY SYSTEM AND METHOD	
The application data sheet is part of the provisional or nonprovisional application for which it is being submitted. The following form contains the bibliographic data arranged in a format specified by the United States Patent and Trademark Office as outlined in 37 CFR 1.76. This document may be completed electronically and submitted to the Office in electronic format using the Electronic Filing System (EFS) or the document may be printed and included in a paper filed application.		

Secrecy Order 37 CFR 5.2

Portions or all of the application associated with this Application Data Sheet may fall under a Secrecy Order pursuant to 37 CFR 5.2 (Paper filers only. Applications that fall under Secrecy Order may not be filed electronically.)

Applicant Information:

Applicant 1					Remove
Applicant Authority		<input checked="" type="radio"/> Inventor		<input type="radio"/> Legal Representative under 35 U.S.C. 117	
				<input type="radio"/> Party of Interest under 35 U.S.C. 118	
Prefix	Given Name	Middle Name	Family Name	Suffix	
	Mark	Andrew	Wood		
Residence Information (Select One)					
<input type="radio"/> US Residency <input checked="" type="radio"/> Non US Residency <input type="radio"/> Active US Military Service					
City	Haslemere	Country Of Residence ⁱ	GB		
Citizenship under 37 CFR 1.41(b) i		GB			
Mailing Address of Applicant:					
Address 1	8 Lion Lane				
Address 2					
City	Haslemere, Surrey	State/Province	GB		
Postal Code	GU17 1JF	Country	GB		
Applicant 2					Remove
Applicant Authority		<input checked="" type="radio"/> Inventor		<input type="radio"/> Legal Representative under 35 U.S.C. 117	
				<input type="radio"/> Party of Interest under 35 U.S.C. 118	
Prefix	Given Name	Middle Name	Family Name	Suffix	
	Kevin	Russell	Preston		
Residence Information (Select One)					
<input type="radio"/> US Residency <input checked="" type="radio"/> Non US Residency <input type="radio"/> Active US Military Service					
City	Gwent	Country Of Residence ⁱ	GB		
Citizenship under 37 CFR 1.41(b) i		GB			
Mailing Address of Applicant:					
Address 1	Nant-y Celslad Farm				
Address 2	Pennilwyn Lane Machen				
City	Gwent	State/Province	GB		
Postal Code	Cf83 8RL	Country	GB		
Applicant 3					Remove
Applicant Authority		<input checked="" type="radio"/> Inventor		<input type="radio"/> Legal Representative under 35 U.S.C. 117	
				<input type="radio"/> Party of Interest under 35 U.S.C. 118	
Prefix	Given Name	Middle Name	Family Name	Suffix	
	Douglas		Weiser		
Residence Information (Select One)					
<input checked="" type="radio"/> US Residency <input type="radio"/> Non US Residency <input type="radio"/> Active US Military Service					
City	Port Richey	State/Province	FL	Country of Residence ⁱ	US

Application Data Sheet 37 CFR 1.76		Attorney Docket Number	ENIT 9834C2	
		Application Number		
Title of Invention	BROADCAST ALERTING MESSAGE AGGREGATOR/GATEWAY SYSTEM AND METHOD			
Citizenship under 37 CFR 1.41(b) i				
Mailing Address of Applicant:				
Address 1	5009 Galleo Ct.			
Address 2				
City	Port Richey	State/Province	FL	
Postal Code	34652	Country ⁱ	US	
All Inventors Must Be Listed - Additional Inventor Information blocks may be generated within this form by selecting the Add button.				<input type="button" value="Add"/>

Correspondence Information:

Enter either Customer Number or complete the Correspondence Information section below. For further information see 37 CFR 1.33(a).			
<input type="checkbox"/> An Address is being provided for the correspondence information of this application.			
Customer Number	01688		
Email Address	patents@polsterlieder.com	<input type="button" value="Add Email"/>	<input type="button" value="Remove Email"/>
Email Address	dhoward@polsterlieder.com	<input type="button" value="Add Email"/>	<input type="button" value="Remove Email"/>

Application Information:

Title of the Invention	BROADCAST ALERTING MESSAGE AGGREGATOR/GATEWAY SYSTEM AND METHOD		
Attorney Docket Number	ENIT 9834C2	Small Entity Status Claimed	<input checked="" type="checkbox"/>
Application Type	Nonprovisional		
Subject Matter	Utility		
Suggested Class (if any)		Sub Class (if any)	
Suggested Technology Center (if any)			
Total Number of Drawing Sheets (if any)	11	Suggested Figure for Publication (if any)	

Publication Information:

<input type="checkbox"/> Request Early Publication (Fee required at time of Request 37 CFR 1.219)
<input type="checkbox"/> Request Not to Publish. I hereby request that the attached application not be published under 35 U.S.C. 122(b) and certify that the invention disclosed in the attached application has not and will not be the subject of an application filed in another country, or under a multilateral international agreement, that requires publication at eighteen months after filing.

Representative Information:

Representative information should be provided for all practitioners having a power of attorney in the application. Providing this information in the Application Data Sheet does not constitute a power of attorney in the application (see 37 CFR 1.32). Enter either Customer Number or complete the Representative Name section below. If both sections are completed the Customer Number will be used for the Representative Information during processing.

Under the Paperwork Reduction Act of 1995, no persons are required to respond to a collection of information unless it contains a valid OMB control number.

Application Data Sheet 37 CFR 1.76		Attorney Docket Number	ENIT 9834C2	
		Application Number		
Title of Invention	BROADCAST ALERTING MESSAGE AGGREGATOR/GATEWAY SYSTEM AND METHOD			
Please Select One:	<input checked="" type="radio"/> Customer Number	<input type="radio"/> US Patent Practitioner	<input type="radio"/> Limited Recognition (37 CFR 11.9)	
Customer Number	01688			

Domestic Benefit/National Stage Information:

This section allows for the applicant to either claim benefit under 35 U.S.C. 119(e), 120, 121, or 365(c) or indicate National Stage entry from a PCT application. Providing this information in the application data sheet constitutes the specific reference required by 35 U.S.C. 119(e) or 120, and 37 CFR 1.78(a)(2) or CFR 1.78(a)(4), and need not otherwise be made part of the specification.

Prior Application Status	Patented		Remove		
Application Number	Continuity Type	Prior Application Number	Filing Date (YYYY-MM-DD)	Patent Number	Issue Date (YYYY-MM-DD)
	Continuation of	12559405	2009-09-14	8073903	2011-12-06
Prior Application Status	Patented		Remove		
Application Number	Continuity Type	Prior Application Number	Filing Date (YYYY-MM-DD)	Patent Number	Issue Date (YYYY-MM-DD)
12/559405	Continuation of	11/057704	2005-02-14	7752259	2010-07-06
Prior Application Status			Remove		
Application Number	Continuity Type	Prior Application Number	Filing Date (YYYY-MM-DD)	Patent Number	Issue Date (YYYY-MM-DD)
11/057704	non provisional of				
Additional Domestic Benefit/National Stage Data may be generated within this form by selecting the Add button.				Add	

Foreign Priority Information:

This section allows for the applicant to claim benefit of foreign priority and to identify any prior foreign application for which priority is not claimed. Providing this information in the application data sheet constitutes the claim for priority as required by 35 U.S.C. 119(b) and 37 CFR 1.55(a).

				Remove	
Application Number	Country ⁱ	Parent Filing Date (YYYY-MM-DD)	Priority Claimed		
			<input type="radio"/> Yes <input checked="" type="radio"/> No		
Additional Foreign Priority Data may be generated within this form by selecting the Add button.				Add	

Assignee Information:

Providing this information in the application data sheet does not substitute for compliance with any requirement of part 3 of Title 37 of the CFR to have an assignment recorded in the Office.

Assignee 1	Remove
If the Assignee is an Organization check here.	<input checked="" type="checkbox"/>
Organization Name	ENVISIONIT LLC

Under the Paperwork Reduction Act of 1995, no persons are required to respond to a collection of information unless it contains a valid OMB control number.

Application Data Sheet 37 CFR 1.76		Attorney Docket Number	ENIT 9834C2	
		Application Number		
Title of Invention	BROADCAST ALERTING MESSAGE AGGREGATOR/GATEWAY SYSTEM AND METHOD			

Mailing Address Information:			
Address 1	17 Research Park Drive, Suite 200		
Address 2			
City	St. Charles	State/Province	MO
Country		Postal Code	63304
Phone Number		Fax Number	
Email Address			
Additional Assignee Data may be generated within this form by selecting the Add button.			<input type="button" value="Add"/>

Signature:

A signature of the applicant or representative is required in accordance with 37 CFR 1.33 and 10.18. Please see 37 CFR 1.4(d) for the form of the signature.					
Signature	/David L. Howard/		Date (YYYY-MM-DD)	2011-12-05	
First Name	David	Last Name	Howard	Registration Number	41502

This collection of information is required by 37 CFR 1.76. The information is required to obtain or retain a benefit by the public which is to file (and by the USPTO to process) an application. Confidentiality is governed by 35 U.S.C. 122 and 37 CFR 1.14. This collection is estimated to take 23 minutes to complete, including gathering, preparing, and submitting the completed application data sheet form to the USPTO. Time will vary depending upon the individual case. Any comments on the amount of time you require to complete this form and/or suggestions for reducing this burden, should be sent to the Chief Information Officer, U.S. Patent and Trademark Office, U.S. Department of Commerce, P.O. Box 1450, Alexandria, VA 22313-1450. DO NOT SEND FEES OR COMPLETED FORMS TO THIS ADDRESS. **SEND TO: Commissioner for Patents, P.O. Box 1450, Alexandria, VA 22313-1450.**

Privacy Act Statement

The Privacy Act of 1974 (P.L. 93-579) requires that you be given certain information in connection with your submission of the attached form related to a patent application or patent. Accordingly, pursuant to the requirements of the Act, please be advised that: (1) the general authority for the collection of this information is 35 U.S.C. 2(b)(2); (2) furnishing of the information solicited is voluntary; and (3) the principal purpose for which the information is used by the U.S. Patent and Trademark Office is to process and/or examine your submission related to a patent application or patent. If you do not furnish the requested information, the U.S. Patent and Trademark Office may not be able to process and/or examine your submission, which may result in termination of proceedings or abandonment of the application or expiration of the patent.

The information provided by you in this form will be subject to the following routine uses:

1. The information on this form will be treated confidentially to the extent allowed under the Freedom of Information Act (5 U.S.C. 552) and the Privacy Act (5 U.S.C. 552a). Records from this system of records may be disclosed to the Department of Justice to determine whether the Freedom of Information Act requires disclosure of these records.
2. A record from this system of records may be disclosed, as a routine use, in the course of presenting evidence to a court, magistrate, or administrative tribunal, including disclosures to opposing counsel in the course of settlement negotiations.
3. A record in this system of records may be disclosed, as a routine use, to a Member of Congress submitting a request involving an individual, to whom the record pertains, when the individual has requested assistance from the Member with respect to the subject matter of the record.
4. A record in this system of records may be disclosed, as a routine use, to a contractor of the Agency having need for the information in order to perform a contract. Recipients of information shall be required to comply with the requirements of the Privacy Act of 1974, as amended, pursuant to 5 U.S.C. 552a(m).
5. A record related to an International Application filed under the Patent Cooperation Treaty in this system of records may be disclosed, as a routine use, to the International Bureau of the World Intellectual Property Organization, pursuant to the Patent Cooperation Treaty.
6. A record in this system of records may be disclosed, as a routine use, to another federal agency for purposes of National Security review (35 U.S.C. 181) and for review pursuant to the Atomic Energy Act (42 U.S.C. 218(c)).
7. A record from this system of records may be disclosed, as a routine use, to the Administrator, General Services, or his/her designee, during an inspection of records conducted by GSA as part of that agency's responsibility to recommend improvements in records management practices and programs, under authority of 44 U.S.C. 2904 and 2906. Such disclosure shall be made in accordance with the GSA regulations governing inspection of records for this purpose, and any other relevant (i.e., GSA or Commerce) directive. Such disclosure shall not be used to make determinations about individuals.
8. A record from this system of records may be disclosed, as a routine use, to the public after either publication of the application pursuant to 35 U.S.C. 122(b) or issuance of a patent pursuant to 35 U.S.C. 151. Further, a record may be disclosed, subject to the limitations of 37 CFR 1.14, as a routine use, to the public if the record was filed in an application which became abandoned or in which the proceedings were terminated and which application is referenced by either a published application, an application open to public inspections or an issued patent.
9. A record from this system of records may be disclosed, as a routine use, to a Federal, State, or local law enforcement agency, if the USPTO becomes aware of a violation or potential violation of law or regulation.

**BROADCAST ALERTING MESSAGE AGGREGATOR/GATEWAY
SYSTEM AND METHOD**

CROSS REFERENCE TO RELATED APPLICATIONS

[0001] This application is a continuation of U.S. Application Serial No. 12/559,405, filed September 14, 2009, which is now U.S. Patent 8,073,903; which was a continuation of U.S. Application Serial No. 11/057,704, filed February 14, 2005, which is now U.S. Patent No. 7,752,259 (issued on July 6, 2010); which was based on Provisional U.S. Application Serial No. 60/544,739, filed February 13, 2004, the entire disclosures of which are incorporated herein by reference.

FIELD

[0002] The present disclosure relates to message broadcast systems and in particular location-specific message broadcasting aggregator and gateways.

BACKGROUND

[0003] With the events of 9/11, there has been increased concern with the ability of present systems for providing public service broadcasting of messages and warnings to the public. Existing public service warning systems are antiquated and provide only limited access to the public who may be in need of knowing of potential emergencies or danger. Additionally, existing systems do not provide for location-based notification or broadcasting.

[0004] As such, there is a need for an improved method and system for providing timely information to the public related to potential hazards affecting them. One suggested solution is the utilization of the subscription-based Short Message Service (SMS) messaging capability for mass messaging using mobile telephones and compatible devices. However, SMS systems and technology have significant technical limitations and experience with such systems has been disappointing due to significant delays in the delivery of SMS messages and negative impacts to the networks due to congestion.

[0005] Short Message Service (SMS) is only offered or available on a limited basis. This is due to the limited technical and network support for the service and is also

due to the service being offered by Mobile Service Providers and wireless network providers on a subscription basis. As such, use of the SMS service capability for emergency broadcasting is very limited.

[0006] Additionally, the use of SMS technology for broadcasting requires enormous network infrastructure utilization. A telecommunication system can suffer from congestion, not only in its voice traffic channels, but also in its narrow-band data channels as are used for the SMS service. To send an SMS message, network components are utilized to provide an SMS message call set up for each individual SMS message recipient. In order to send a single SMS message, all SMS message call processing procedures have to be repeated for each and every message, one by one, for all intended recipients. A single SMS message requires signaling and processor capacity and utilization similar to that required to establish a voice call. As such, the impact on network resources for broadcasting SMS messages is the same as having thousands of phone users attempt to initiate a voice call at the same time. Telecommunication networks are not designed or deployed to handle such high levels of simultaneous call attempts.

[0007] When an SMS message is transmitted, the SMS message is signaled to an SMS center of the telecommunication service provider. The SMS center acknowledges each and every requested SMS message individually and attempts to deliver the SMS message through an interrogation of the Home Location Register (HLR) of the telecommunication service. An HLR is a data base which registers or keeps track of the presence of a mobile unit user within the HLR's defined serving network. The HLR queries the database and determines whether the intended SMS message recipient is currently attached to the network and if so, to which network switch the user is attached. The HLR is queried using the telecommunication signaling network.

[0008] If an intended user is located or attached to a switch in the telecommunication service provider's network, the particular network switch is signaled over the telecommunications signaling network to set up the SMS message call. That serving network switch of the mobile carrier initiates a query or message attempt to every cell in the location area where the intended user's mobile unit was last known to be operating. If the intended recipient is located in the particular cell area, the mobile unit is

paged. As such, potentially thousand of cells are queried in order to determine the presence of an intended mobile unit. Each queried cell requires paging and calling capacity resources for each mobile unit which is attempted to be paged. In some cases, if the mobile unit does not reply, the whole Mobile Service Carrier (MSC) area is paged which in many instances requires the paging of several thousands of cells.

[0009] When the mobile unit replies by sending an access burst to the cell transceiver currently serving the mobile unit, the cell site allocates a stand-alone dedicated control channel (SDCCH) to perform SMS call set up with the mobile unit. Next, a cipher key is sent by the Home Location Register (HLR)/Authentication Center (AUC) to the mobile unit, assuming that the mobile unit had previously activated the ciphering of the channel. Once the cipher key is successfully received and acknowledged, the SMS message is sent over the control channel to the mobile unit. The SMS message transmission utilizes about 5 seconds of control channel time per SMS message.

[0010] If, however, the intended recipient is not located in the home serving area of the HLR, then signaling message is sent to the serving mobile network's Visitor Location Register (VLR). The VLR registers and tracks mobile unit users who are outside of their home location. In that case, the VLR is queried via the signaling network to verify that the user is currently attached to the remote switch.

[0011] Each SMS message is a narrow-cast message in that each message is generated and transmitted via the SMS Center to a particular telecommunication user or unit. The SMS message is delivered, as discussed above, to the intended recipient by capable networks wherever the intended recipient is located, independent of geographic area or location.

[0012] As such, SMS messaging for emergency-based messaging requires that SMS messages be created and sent to each mobile unit even though the particular user phone is not located in the particular geographic area in which the emergency is located. SMS service is not capable of position-specific messaging.

[0013] Additionally, SMS messaging requires considerable call processing load on the telecommunication system and infrastructure considering that the above process is multiplied by the demand of thousands or tens of thousands of SMS call set up requests at

the same time. The potential initiation of broadcast SMS volumes will not only affect network resources for SMS messaging, but also negatively affect ability of the telecommunication networks to set up and support voice traffic during any period of message broadcasting as these resources are shared by both services.

[0014] As a further example of the limitation of existing solutions to message broadcasting, the well deployed Global Standard for Mobile Communications (GSM) system typically deploys in a single GSM cell several transceivers. A typical GSM cell configuration includes between 6 and 12 transceivers. Each such transceiver includes 8-timeslots. Each timeslot supports a single phone call.

[0015] In such an arrangement, one of the transceivers is selected to be the SMS carrier. The SMS carrier transceiver is arranged differently, having one timeslot dedicated to broadcast SMS messages and paging and another one which is utilized to from 8 control channels which are referred to as Stand-Alone Dedicated Control Channels (SDCCH). The SDCCH carry out control and call set-up functions and carry the SMS traffic which is not normally handled by the traffic channels on the other timeslots.

[0016] However, in this prior art system, SMS and Wireless Access Protocol (WAP) messaging utilize capacity on these channels making them unavailable for other purposes such as voice call set up. Additionally, each of the SDCCH channels can only handle a limited number of SMS and/or paging calls. As such, during heavy messaging, the related high volumes of messaging traffic may have a negative affect on other services including the set up of voice calls.

[0017] To compensate for these and other SMS messaging limitations, dynamic channel allocation was developed. Dynamic channel allocation utilizes an additional traffic channel which is converted into another 8 control channels for the duration of the peak SMS or paging loads. However, this results in the loss of the traffic channel for voice communications.

[0018] Further strategies have included the immediate assignment to a traffic channel. In this system, when a voice call is attempted, the voice call is sent to a traffic channel directly where signaling will be performed on the traffic channel. This, however, occupies the traffic channel for a longer time than would otherwise be the case. There is

a limit on the number of traffic channels that can utilize this feature. In most cases, only one traffic channel is converted thereby only limited the solution to 8 new SDCCH channels. The impact of call failure due to control channel depends on the traffic capacity of the cell. In high density cells, when a large quantity of SMS messaging traffic is offered, congestion occurs due to the each cell having over one hundred traffic channels within the cell.

[0019] In operation, the telecommunication service provider addresses this limitation by throttling the SMS messaging rate so that it is manageable and does not create congestion problems. However, such message load management negatively impacts the opportunity for using SMS messaging for broadcasting emergency messages to users of those networks. Throttling often significantly delays the delivery of the SMS message, even though it's timing delivery in an emergency is critical. Furthermore, if a message fails to be delivered, the SMS center repeatedly attempts to deliver the message, thereby causing further congestion and message backlog.

[0020] Additionally, as discussed SMS messaging is not location based and does not send messages to intended recipients located within a defined geographic location. Since many telecommunication users will be messages independent of their location, many of the generated SMS messages are sent to users who are not in the intended area.

[0021] In the alternative, some next-generation phone systems include a basic cell-based broadcasting capability, e.g., GSM, CDMA and UMTS. In such systems, the cell broadcasting capability allocates a portion of each timeslot bandwidth capacity in each cell as a reserved broadcast timeslot. While the cell broadcast capability is included in many new equipment being deployed, cell broadcasting systems and services have not been developed which effectively utilize the technology.

SUMMARY

[0022] The embodiments of the present disclosure provide one or more improvements over the prior art.

[0023] In one aspect, a message alert broadcast broker system for providing a broadcast message to a plurality of user devices located within a geographically defined broadcast target area, the system including a broadcast service bureau communicatively coupled for receiving from one of a plurality of coupled broadcast agent access systems providing a broadcast request from an originating broadcast agent associated one broadcast agent message origination systems. The received broadcast request includes a broadcast agent identification, the geographically defined broadcast target area, and a broadcast message, the broadcast service bureau configured for verifying the broadcast request as a function of the broadcast agent identification including an authority of the originating broadcast agent to send the broadcast message to the broadcast target area. The broadcast service bureau processing the verified broadcast request for transmission to one or more broadcast message networks providing broadcast message alerting service to at least a portion of the broadcast target area.

[0024] In another aspect, a method of public service broadcast messaging to a broadcast target area, the method including receiving over an input interface a broadcast request including a broadcast agent identification, a geographically defined broadcast target area, and a broadcast message from one of a plurality of coupled broadcast agent message origination systems. The method also includes verifying an authority of the broadcast agent identification including an authority of the originating broadcast agent to send the broadcast message to the broadcast target area. The method further includes transmitting the broadcast message over an output interface to one or more coupled broadcast message networks providing broadcast message alerting service to at least a portion of the broadcast target area.

[0025] Further aspects of the present disclosure will become apparent from the detailed description provided hereinafter. It should be understood that the detailed description and specific examples, while indicating the preferred embodiment of the disclosure, are intended for purposes of illustration only and are not intended to limit the scope of the disclosure.

BRIEF DESCRIPTION OF THE DRAWINGS

[0026] The present disclosure will become more fully understood from the detailed description and the accompanying drawings.

[0027] FIG. 1 is a functional block diagram of a public service message location broadcast system according to one embodiment.

[0028] FIG. 2 is a second functional block diagram of a public service message location broadcast system according to one embodiment.

[0029] FIG. 3 is a flow chart for an admission control process within the public service message location broadcast system service bureau according to one embodiment.

[0030] FIG. 4 is a screen shot of the Broadcast Agent Portal Webpage.

[0031] FIG. 5 is a screen shot of the Broadcast Agent Portal Webpage illustrating a Broadcast Agents initial designation of a target broadcast area.

[0032] FIG. 6 is a screen shot of the Broadcast Agent Portal Webpage illustrating use of a shape tool to refine the designation of a target broadcast area.

[0033] FIG. 7 is a screen shot of the Broadcast Agent Portal Webpage illustrating a library of foot print or predefined target broadcast areas.

[0034] FIG. 8 is a screen shot of the Broadcast Agent Portal Webpage illustrating a dialogue box enabling the Broadcast Agent to create a message and parameters of the Broadcast Request.

[0035] FIG. 9 a screen shot of the Broadcast Agent Portal Webpage illustrating a library of target broadcast areas and a library of messages.

[0036] FIG. 10 is a screen shot of the Broadcast Agent Portal Webpage illustrating a Broadcast Agent Confirmation Entry prompt/window.

[0037] FIG. 11 is a second flow chart for an admission control process within the public service message location broadcast system service bureau as shown in FIG. 3 according to another embodiment.

[0038] Corresponding reference characters indicate corresponding parts throughout the several views of the drawings.

DETAILED DESCRIPTION

[0039] The following description is merely exemplary in nature and is in no way intended to limit the disclosure, its application, or uses.

[0040] The public service message location broadcasting system (PLBS) according to one or more embodiments provide for an improved system and method for public service broadcast messaging. A public service message location broadcasting system (PLBS) operator provides a Broadcast Agent Web Portal or Webpage or other similar GUI interface, implementation and maintenance of the networks' cell-broadcast messaging components, networks and platforms, administration and operation of the public service message location broadcasting system, and interfaces to local telecommunication service providers including mobile unit service providers.

[0041] According to one embodiment in the event of a serious public emergency, a short text message is sent over the location broadcast channel. A mobile unit or Broadcast Agent phone that is configured to receive location broadcast messages, which is in the idle mode and which is located in the predefined cell receives the broadcast message and displays the message on its screen.

[0042] Location broadcasting is transmitted from the predefined cell in a downlink only mode and therefore does not require functionality or network resources from the mobile services provider or from their any portion of the mobile service provider's mobility management resources, e.g., HLR, VLR, etc.

[0043] Public service message location broadcasting system provides for the simultaneous sending of public service messages to millions of subscribers with less impact on the supporting networks than a single SMS-message. As such, minimal to no network congestion will result.

[0044] A public service message location broadcasting system (PLBS) receives emergency or public service messaging and identification of the target broadcast area from public service or government entities. The PLBS provides location broadcast message enablement, security and multi-carrier interoperability and connectivity to the telecommunication service providers offering services within the target broadcast area.

[0045] A public service message location broadcasting system and method according to one or more embodiments provides for the development, transmission,

delivery and display of a message that is an official government-to-citizen information broadcast to all compatible telecommunication receiving devices in, or entering, an predefined at-risk geographic location or area.

[0046] The PLBS system sends any public service or emergency information associated with any event, determined by authorized messaging entities that may affect public safety. These include utility outages, missing child alerts, severe weather warnings, flood warnings, and terrorist threat warnings. The messages are broadcast by public service message location broadcasting systems participating with local telecommunication networks.

[0047] Unlike other emergency messaging services that require the recipient's identity, a predetermined fixed delivery location, and usually the payment of a service fee, public service message location broadcasting system uses broadcast messaging technology to reach an unlimited number of people in real time, with no pre-event subscriber action required.

[0048] Public service message location broadcasting system uses cell-broadcast SMS (C-BSMS) technology to provide a message or alert to a single cell geographic location, a neighborhood, a city, or an entire nation with minimal impact to the hosting telecommunication networks.

[0049] Local telecommunications service providers such as mobile or cellular telephone service providers provide the local infrastructure and deployed technologies to enable the service message location broadcasting system to transmit public messages in a timely manner to the public that may be at risk using a standard and commonplace mobile telephone unit.

[0050] The public service message location broadcast system and methods described herein provide the functions and steps necessary to ensure that the Broadcast Agents are authorized to send the requested broadcast messages to the defined broadcast target area. The PLBS configuration described herein provide for internal controls for insuring that the network and components are secure and that messages are authorized prior to transmittal. The public service message location broadcast system provides the interface to the Broadcast Agents to ensure simple and timely definition of the broadcast target area, the message and the authentication of the Broadcast Agent. The public

service message location broadcast system also provides the interconnectivity and functionality for interface or the number telecommunication service providers which provide for the delivery of the broadcast message to the broadcast target area.

[0051] The public service message location broadcasting system consists of five parts:

- [0052]** 1. Public Service Location Broadcast Service Bureau
- [0053]** 2. Broadcast Agent Terminal/Web Portal/Web Page
- [0054]** 3. Public Service Broadcast Controller
- [0055]** 4. Carrier Broadcast Center
- [0056]** 5. Public Service Location Broadcast Reporter

[0057] The Public Service Location Broadcast Service Bureau (PLB-SB) is located at a PLBS Operators location which is preferably secure. The PLBS-SB ensures the authenticity of the message and the authority of the sender to create such a message. Administrative Operators establish the User Profile in the Administration Subsystem to control Broadcast Agent rights and privileges. The signal from the Broadcast Agent Terminal, for example, at the police station, to the PLBS-SB, would only indicate the geographical area to be covered, plus the message. PLBS-SB then sends the broadcast request signal to the Carrier Broadcast Center at the office of each local carrier concerned.

[0058] PLBS-SB may also perform a billing gateway administrative function as may be required to allocate costs. PLBS-SB can utilize stored location broadcast messaging data and may have access, in one embodiment, to the geographical coverage requested by the Public Service Broadcast Agent. PLBS-SB may be configured to determine or calculate population density of the broadcast area. PLBS-SB may also manage customer account data, authentication, security, and administration and application of restrictions on a customer, jurisdiction, or Broadcast Agent.

[0059] For each account, a Broadcast Agent Administrator is appointed. A person of whose authority is recognized, such as a police chief or city manager would be suitable for such a role, though he may likely delegate this to someone in the Information Technology services group. The Broadcast Agent Administrator (or his delegate) has

under his control several Broadcast Agent accounts, which have authority under him, but on no account greater. For example, the jurisdiction of a Broadcast Agent is within that of a Broadcast Agent Administrator.

[0060] Using the PLBS-SB, an Administrative Operator checks and/or verifies the authenticity of the Broadcast Agent Administrator and defines or validates the jurisdictional area of the Broadcast Agent's organization. The Administrative Operator administers customer and agent profiles within the PLBS Service Bureau System. The Administrative Operator has secure access for administering the operational and administrative data and profiles for operation of the PLBS-SB. Best practices and Memoranda of Understanding (MOU) are defined by government agencies and/or local carriers. For example, a Coast Guard commander may have access only to costal areas, though the area would be very large. In another example, a River Authority manager would have a guideline indicating that he could warn of imminent flooding, but not urge people to shower less. The river authority Jurisdiction may include only rivers, waterways and flood plains.

[0061] Any data and/or factor may be input to the PLBS-SB by the Administrative Operator and used by the PLBS-SB for system operation. Each Broadcast Agent Administrator has an account to which the Broadcast Agent belongs. The account is updated to indicate usage accumulated by the Broadcast Agent Administrator. Factors and data recorded include:

- [0062]** 1. Language or Languages for warnings
- [0063]** 2. Broadcast Agent Administrator account holder contact details
- [0064]** 3. Total number of messages broadcast
- [0065]** 4. Total Pops reached
- [0066]** 5. Mess-Pops figure (number of messages times the pops reached)
- [0067]** 6. Log, (Each broadcast is recorded on the account for later review)
- [0068]** 7. Date of expiry of contract
- [0069]** 8. Which networks are permitted for this Broadcast Agent

Administrator?

- [0070]** 9. Which channel numbers are allowed?
- [0071]** 10. Message, Footprint and Broadcast libraries

- [0072]** 11. Jurisdictional limits
- [0073]** 12. Pop limits
- [0074]** 13. Message length limits
- [0075]** 14. Language for web portal
- [0076]** 15. Report parameters and addresses
- [0077]** 16. Admissions rules and operational events such as denials of service.

[0078] In some circumstances a report in the form of an e-mail or web-page may be sent or made available to the Administrative Operator and/or the Broadcast Agent Administrator. Such a report may include a warning that the account credit is about to expire, or the status of an account or activity. Such reports may be defined or requested or provided one a regular or specified interval.

[0079] Service may be automatically denied to a Broadcast Agent or Broadcast Agent Administrator who has exceeded his quota.

[0080] In other cases information about account status may be signaled to the Broadcast Agent at log on and when proposing messages. This may cause the Broadcast Agent to think again about conserving his quota if near to his limit.

[0081] The PLBS-SB may also define broadcast message jurisdiction is a geographical area for a particular Broadcast Agent Administrator and associated Broadcast Agents. Broadcast Message Jurisdiction may define any number of factors, data, or services. A first is definition or allocation of geographic territory or areas to be accessed or displayed in map format to the Broadcast Agents of the Broadcast Agent Administrator. Additional, all or a portion of the Broadcast Message Jurisdiction may be enabled or disabled for defining one or more broadcast message target areas or "Broadcast Target Area/Footprints" in which a public service broadcast message is to be sent. A second is the identification and specification of carrier or telecommunication local carriers that will be included in the public service location broadcast message messages originated by the particular Broadcast Agent Administrator or Broadcast Agent. This may also include defining one or more networks, network components (such as Carrier Broadcast Center or network switching centers) or sub-networks to be provided the broadcast messages.

[0082] The Broadcast Agent Administrator is capable of setting further restrictions or rules related to its Broadcast Message Jurisdiction and one or more Broadcast Agents under its control or within its Broadcast Message Jurisdiction. For example, it may establish differ levels of authority for various personnel within a police department or fire department or allocation sub-areas or sub-jurisdictions based on police or fire department sub-boundaries.

[0083] For each Broadcast Agent Administrator, the Broadcast Target Area/Footprint Library is generated and shared among the Broadcast Agents. However in some cases, the Broadcast Agent Administrator may wish to pre-define Broadcast Target Area/Footprints on the basis of existing agreements. For example, these may include tornado watch boxes or mandated warning zones around a chemical plant.

[0084] In this case, the Broadcast Agent Administrator has the option to allow some Broadcast Agents only to access the Broadcast Target Area/Footprint library, or to be able to use the library and the map tool. Other Broadcast Agents may have the authority to create new Broadcast Target Area/Footprints and store them in the library.

[0085] In some cases, the Broadcast Target Area/Footprint area may be complex. An advanced Footprint Library feature will enable the Broadcast Agent to pre-define areas to be covered, and store them in a library of Broadcast Target Area/Footprints specific to that Broadcast Agent. For example, the flood plain area of a river may be complex to define with a simple mouse click. You would want to get that done ahead of time, then call it back quickly when an urgent message is imminent. In another case, a tornado warning box is pre-defined by political means and may be easier to refer to as such.

[0086] This feature may also be required if a particular Broadcast Agent only has authority to cover, for example, major highways or coastal areas such as beaches. These can be pre defined by an Administrative Operator and then locked so that the Broadcast Agent has limited authority as to the Broadcast Target Area/Footprint's area.

[0087] There is no limit on how many users one message can reach and in theory an authorized operator may send the message to everyone in the country at the same time. Since most authority is relatively limited, the account may be set established on a per Broadcast Agent basis thereby determining the area to be addressed by one message. An

Admission Control feature checks new message for a pop figure before agreeing to proceed. If not, the message is declined and the Broadcast Agent receives a message and report with an explanation. To continue, the Broadcast Agent can either set the area to one less ambitious, or request authorization from another Broadcast Agent with more pop authority. The pop figure may also be used to generate usage statistics which the administration system would record for each Broadcast Agent. If a Broadcast Agent has exceeded the agreed limit, the account can be closed and an e-mail sent to the Broadcast Agent Administrator explaining this.

[0088] Control of Pops is also provided for the local carriers because the spacing of Radio Base Stations when very closely to population density. A dense urban area may be covered by more cells than the same corresponding area in a rural environment. From a signaling point of view more cells are signaled for an area in the city than in the country. Therefore the relationship between pops and network load is a valid one. For example, the number of messages times the population they have targeted [Mess*Pops] is one possible strategy for working out billing, since we have pop figures directly from the reports generated by account administration.

[0089] A Broadcast message may consist of 15 82-character messages linked together. The standard default maximum size of a message may be that used by second generation GSM systems, which is 93 characters, or 82 octets of data. However, in practice each message should be less in order to support multiple language messages and for practical application reasons. The Broadcast Agent Administrator may set limits on the length of an individual message. The Broadcast Agent Administrator may also set a limit on how much in total has been sent by all of the Broadcast Agents within his control. An extended-message button on the advanced message dialogue box provides for setting further message contents as required. For future systems, messages may include multimedia messages such as photographs or maps. In such a case, a multimedia facility dialogue box is utilized.

[0090] The Broadcast Agent Administrator may also pre-define set messages in the message library, so that some accounts may broadcast only these messages. Others may be able to create their own and store them in the library. Past messages are also stored in the message library for later recall or repetition. Either from the advanced menu

or from an advanced button on the quick message box, the Broadcast Agent can select the advanced message panel. Here the Broadcast Agent has many more options to control messages. For example, a particular message may be used frequently, or the precise wording of a message may have been agreed at higher political level in advance and only this wording is agreed. In such a case, the Broadcast Agent selects from a Message Library of standard messages available to this Broadcast Agent. The system stores past messages and is capable of retrieving them for re-transmission.

[0091] The system provides for the ability to repeat a message if the emergency continues for a long time, as the location broadcast message will only last for a limited period and will need to be repeated. In other cases, the broadcast event may be triggered by an automatic machine such as a water level device. If so the event triggers the pre-defined message as set up by agreements ahead of time between the Broadcast Agent Administrator for that organization and the Administrative Operator who administers the accounts on the PLBS-SB in accordance with guidelines agreed with government authorities and local carriers.

[0092] A Broadcast Request includes both the message and the Broadcast Target Area/Footprint together. In some cases both the Broadcast Target Area/Footprint and the message may be pre defined by one group of Broadcast Agents giving other Broadcast Agents only the choice as to when to send the message. The Broadcast library also keeps copies of previously sent messages, and their Broadcast Target Area/Footprints, for fast recall and for internal management reasons within the Broadcast Agent organization.

[0093] The system also provides for the broadcasting of public messages that are in several languages. In this case the Broadcast Agent will not be allowed to proceed until messages in the other languages have been compiled. Alternatively the broadcast message may be sent in each language as each is entered. Otherwise translation servers can be signaled for a best effort translation. The account administration parameters will determine this.

[0094] In many cases, users may be travelers from an area where a different language is the primary language. If so, by keeping separate channels for warnings in each language, the user may receive a message in his own language. This may also be required in multilingual countries or portions of countries such as along a border. The

PLBS Operator or Broadcast Agent Administrator may also be required by government authorities to send messages in more than one language. If so, the Administration system reminds the Broadcast Agent to open up messages for all the languages required. It will then link them together so that when one is recalled, they are all recalled together and treated as if the same message.

[0095] The Broadcast Agent may not be able to read and write the message in the other language, for example, he may not read Chinese or Arabic. In this case, he can go to the library of messages, which will automatically match the other language message. However this restricts the message to those not containing any variables.

[0096] If the Broadcast Agent decides to recall a message from the network and order that its broadcast cease, the linkage will ensure that all languages are recalled at the same time.

[0097] The system also provides for the specification of how long a single broadcast continues to be broadcast. For example, for many situations a 20 minute broadcast may be long enough, after which a new command to send the message again is initiated. The PLBS system may provide for a default time to be set in the Broadcast Agent account. Additionally, in the advanced menu options, the Broadcast Agent may be enabled to set start and stop time.

[0098] In other cases, Carriers or their networks may require that the broadcast message have a start time and stop time specified to the cell. The message is held at the cell and transmitted only when the start time arises, then transmission will be at regular intervals until the stop time arises, unless a command is received by the cell to cease the message. As such, the PLBS includes a default start time that is set by the PLBS-SB to be NOW, and the stop time to be 20 minutes. In some situations, the Broadcast Agent may have authority to set up messages for delivery at a pre-determined time in advance, or to set the broadcast time for a longer or shorter time. For example, the Broadcast Agent may be planning a highway shutdown, and may pre-program the night's messages accordingly. This frees manpower at the busy command center at the very moment when attention may be needed on the radio and elsewhere.

[0099] In the advanced message window, a start and stop time box may appear which is set to the defaults. The Broadcast Agent has the option to change these, but as

usual the administration system will check that the Broadcast Agent has authority to do so before proceeding with the message.

[00100] Channel codes define the type of message sent, which in turn defines the type of people being broadcasted to. The subscriber who owns the terminal has to switch on or off the channels at his discretion. The account will define which channel codes are defaults for this Broadcast Agent and which are allowed.

[00101] The Broadcast message is preceded by a channel code. Users may be given the option to select the type of messages they want to receive by going through a menu on their phone. Some mobile phones are sold with the default state set to disable the receipt of messages. However, to enable mass distribution of broadcast message, the channel numbers are defined for the various message types.

[00102] In any case, the Broadcast Agent may have another special need in mind other than to address the public for warnings. The Broadcast Agent may, for example, want to address only police officers or neighborhood watch volunteers in the area. In other instances, there may be automatic equipment in the area which needs to be commanded to perform in a certain way in some conditions and locations, for example, sirens to sound. If so, a different channel number is defined.

[00103] If the Broadcast Agent has the authority, the channel number may be changed. In the simple version, the default is the standard code for public safety messaging. In any case this code is checked against the Broadcast Agent profile by the Broadcast Agent Administrator before the message is sent to verify the authority of the Broadcast Agent.

[00104] In many areas, more than one official language is used. In such regions, people speaking one language, can be regularly crossing borders into countries which in themselves have multiple official languages, with primacy in different order. In other cases, such as the maritime service, information should be on the same code, regardless of which country the ship is in range of. Therefore, the system provides for the ability to transmit alert messages in all major official languages for a region. The system provides a mechanism to give the networks and governmental authorities flexibility in addressing this requirement.

[00105] Users may be required to turn one or more functions of their phone. The user may be motivated to do that if he knows that he will get messages in his language. If the user can speak more than one language, he can enable more than one code at his discretion. In addition, if the user is a tourist or traveling businessman, he will get messages in his own language if that host country transmits them as such. For example, at airports, authorities may decide to transmit in English as well as the official languages, so as to warn passengers regardless if they speak the local language or not. Popular holiday resorts are another example.

[00106] Furthermore there may be politically sensitive positions regarding which language is the first and which the second. In one embodiment, pre-assigning codes according the internationally recognized order specified in ISO 639 may be implemented. The use of 145 codes covers most languages (plus some spare for special cases). However, a network may use the unused codes for another purpose. In any case since there are 1,000 codes available, this loss is a low price to pay in return for a good solution.

[00107] There are some cases where internationally agreed codes are required. One case in point is that of the maritime service channel. Many small pleasure craft and small coastal fishing vessels are not fitted with marine radio equipment. However in many cases one of the occupants of the boat does have a mobile unit in their possession. Certainly most large ships do have a GSM installation. If so the coastal authorities may decide to relay maritime safety information over a CB maritime service channel. If so, we could expect coastal shipping to switch on this channel. In that case, the channel number should be the same for every port the ship may visit, requiring an internationally assigned channel. In another example, the United Nations (UN) has the responsibility to care for the security concerns of all international relief workers working for them and any Non Governmental Organizations (NGOs). If the UN security - coordinator (UNSECORD) had a standard channel, then this highly mobile but very vulnerable group would be reachable on a geographically specific basis, but without having to change the channel number on their phone each time they change border. These two examples, while extreme, show the benefits of the current system for supporting multi-border Broadcast Agents.

ENIT 9834C2

[00108] One embodiment of a coding scheme consistent with the PLBS is provided in Appendix 1.

[00109] All broadcast messages are logged by the PLBS-SB in the logfile and cannot be tampered with by the Broadcast Agent or Administrative Operator. In the case of any dispute over a message, the Broadcast Agent Administrator, the Administrative Operator, and/or a government authority may view the log to establish what has occurred.

[00110] This file may also be used for off line statistics and account administration. The reporting system may send a copy by e-mail to the Broadcast Agent and/or Broadcast Agent Administrators if required. In some cases billing can be derived from the message log and an off line billing gateway program which would use agreed information to derive billing.

[00111] The Broadcast Agent requires the permission of the local carrier to use their network for this purpose. The administration of individual accounts is provided to the Administrative Operator to define network guidelines for each Broadcast Agent Administrator. For each Broadcast Agent Administrator, the carriers who have agreed to carry his traffic are signaled individually. Broadcast Agent Administrator is provided with the ability to customize the interface between the various carriers to match the protocols or business requirements of the carriers.

[00112] The message is transmitted to the carrier for broadcast transmission over their network. In most cases, the message is transmitted by every known operator offering coverage of the area and may include mobile carriers, digital private radio systems operators, private radio system operators, internet providers, wireline telecommunication service providers, satellite service providers, CATV operators, etc.

[00113] The PLBS-SB sends a copy of the message and geographical information about the Broadcast Target Area/Footprint required to each operator's network center for further processing by the Carrier Broadcast Center (CBC) to determine which cells are involved, then send the signals to the correct switching center or Gateway platform. Some messages may be intended only for the private digital radio system used by the organization such as a police radio network. In other cases, sending a

multimedia message such as a map or photo to a text-capable 2G network may not be applicable.

[00114] Carriers or telecommunications operators may decline to accept messages from a message source, or of a particular subject matter, context, or content. In each case, the networks which have been selected may be checked by an Administration Subsystem or Administrative Entity before the message is transmitted.

[00115] In some cases the sender may decide to recall the message before it has elapsed its time. In this case the Broadcast Agent will select the message from the message library and press the recall button. Administration sends the recall command to the concerned networks or carriers.

[00116] Emergency situations are very dynamic, and the situation may change shortly after sending the message and before the expiry of the message time. If so, the PLBS provides the Broadcast Agent with the ability to recall the message. The system also includes a recall button to recall the message as displayed in the window. Each message is given a daily number for fast recall purposes.

[00117] The User may wish to know that the broadcast has indeed been passed to the networks for broadcasting. This can be by an e-mail or a report box on the browser.

[00118] Since the actual broadcast is managed by the local carrier through his network of gateways and switches, PLBS-SB cannot have any further influence on the process after the handoff to the network has been done. Therefore any progress information we can pass back is only valid up to the moment of handoff.

[00119] The report system can send a pop up window back to the Broadcast Agent provided he has not logged off the server by then. This can show ticks indicating that the message was handed off to network. However it does not indicate that the message is actually being transmitted at this time.

[0100] Optionally the report system can send an e-mail to the Broadcast Agent Administrator to inform him that messages have been sent. Should any irregularities occur or other trigger events, such as the near exhaustion of agreed messages, then a report can be sent to the Broadcast Agent Administrators e-mail reporting this.

[0101] Reports may be automatically generated as plain text messages and sent to an electronic address or e-mail account defined by the Broadcast Agent Administrator and/or Administrative Operator.

[0102] The Web Portal, as hosted directly or indirectly by the PLBS Service Bureau communicates with a Web Browser at the Broadcast Agent's location, as discussed below. The objective of the Portal is the creation of a Broadcast Request, a file which holds the following information.

[0103] a. Broadcast Target Area/Footprint

[0104] b. Broadcast Message and related parameters

[0105] c. Broadcast Agent User ID and Password.

[0106] d. Status of the Broadcast Request, (times Proposed, Authenticated, Handed off) and status reports.

[0107] The Admission Control Subsystem ensures that the proposed Broadcast Request by the particular Broadcast Agent at this time is authentic before passing it to the networks.

[0108] For the Broadcast Agent and session, the Portal provides an environment for the Broadcast Agent consisting of the maps of his jurisdiction and the Broadcast Target Area/Footprint, message and broadcast libraries that apply. Portal gets this information from the Account data. When the Multi-Language feature is required, appropriate windows will be provided in the message window.

[0109] Broadcast Agent Web Portal creates a Broadcast Request record with the name of being the current system date and time from when the Create Message button was pressed.

[0110] When the Broadcast Agent presses the GO-button, the Admission system fetches the Broadcast Agent profile from the account database. It will now check all the parameters of the Broadcast Agent and message to see if the message will be admitted or declined.

[0111] When a message is declined, the Broadcast Record is marked as such by its status register and sent to reporting; a report is then generated and e-mailed as per the parameters in the account data. The broadcast record is then stored along with the reports in the broadcast log. The Broadcast Agent creates a new broadcast which has a new number.

[0112] The Broadcast Agent ID and password details are then checked against the profile to authenticate the Broadcast Agent. If not authentic then the message is declined. Admission will then check the Broadcast Target Area/Footprint against the profile, If not within the Jurisdiction, and then the message will be declined. Admission will then calculate the Pops figure for this message by multiplying the area derived from the Broadcast Target Area/Footprint, by the population density. Population density figure is fetched from Account data. The [total messages], [Pop density], and [total mess*pop] figure is then fetched from the account data, and the new figure is added in the broadcast record but not written into the account data. The total result is checked against the limits set in account data. If the limit is exceeded then the admission rules are checked to see if the broadcast may go ahead or not. If not then the message is declined. Alternatively a report may be generated according to the admission rules.

[0113] Multi language messaging checks may be performed to see if the Broadcast Agent has defined a message for each language as required by the government authorities. If not then the Broadcast may or may not be declined according to admission control rules.

[0114] The networks requested are checked against the Account Data. Portal may have defined networks that the account data has indicated, however in some cases some networks may accept some channels while others do not. If so, the broadcast may continue on the allowed networks and declined on others, or it may be declined altogether.

[0115] If Admission is satisfied that the Broadcast Request is valid, then it is sent to the distribution system.

[0116] The Admission control ensures that that any Broadcast Request meets with the approval based on preset guidelines. The parameters as to what is acceptable and what is not are set by the Administrative Operator in the Administration Data Base.

ENIT 9834C2

Each registered Broadcast Agent, that is everyone who is allowed to create Broadcasts, has a separate Profile recorded in the Administration Database. Only the Administrative Operator has access to this file and can create, edit and delete Broadcast Agents. All Broadcast Agents belong to a Broadcast Agent Administrator, and may on no account have authority exceeding their Broadcast Agent Administrator.

[0117] The parameters used in the Administration Data Base are reviewed in the PLBS-SB System description document. There are other parameters about the User ID, the Broadcast Agent Administrator to whom the Broadcast Agent reports, and the current password and authentication key for each Broadcast Agent that may also be included.

[0118] The Administration subsystem is responsible for creating an object called the Broadcast Request. This file details everything known about each proposal. It also contains a check list of flags which are used by the system to track the progress of each Broadcast Request. A Broadcast Request is known by a unique ID consisting of the PLBS-SB which accepted the proposal, and the date time group identifying when it was accepted as a valid proposal.

[0119] When the Broadcast Agent presses the "propose" or "GO" button, Administration will check that the Broadcast Request has been created with enough required information, and is formatted correctly. When the Proposal is correctly formatted, it is recorded in the logfile data base, in an area where pending proposals are kept. The Administration system then orders the Admission control system to run.

[0120] Referring to Figs. 3 and 11, the methods 300 and 1100 are admission control processes within the public service message location broadcast system service bureau and utilize the convention of having a yes answer coming out of the side, and a no answer from the bottom is applicable unless otherwise indicated.

[0121] Next Broadcast Agent - When activated, the Admission Control (admission) fetches the next Broadcast Agent from the logfile area where pending Broadcast Agents are waiting as shown in Process 302. The AC also copies all the parameters.

[0122] Fetch User Profile - The User ID is read and the Broadcast Agent profile is fetched from the Administration Data Base as shown in Process 304.

[0123] Security Fail - The User ID is checked against the password and authentication key entered in the database as shown in Process 306. (The Administration control system has validated the data link and network address of the originating terminal in the case of secure tunneling or Virtual Private Network or VPN access).

[0124] Security Report - If the security check fails, a short message explaining the reason for the failure is generated as shown in Process 308. The short message is appended to the report field for this Broadcast Request. In the case of a security offense or alert, additional data may be included such as details related to the attempted action.

[0125] All Decline Flags Set - To avoid a transmission of this Broadcast Agent, the Decline Flag is set for a Broadcast Request on all the network fields to restrict transmission as shown in Process 310.

[0126] Next Network - If there is no security problem, the Broadcast Request is examined to see which is the first network to be attempted. See Process 312. The Admission Parameters for this network will now be queried from the Administration Data Base and examined in Process 312. When this is performed for all networks, a copy of the Broadcast Request is sent to the distributor system that converts the Broadcast Request into a signal for sending to the Carrier Broadcast Center at the Network management center. A communication protocol is used which may be a standard protocol or an application specific protocol such as a Broadcast Message Submission Protocol (BMSP)).

[0127] All Nets Done - The end of file marker is checked and read to determine whether all required networks have been analyzed as shown in Process 314. When all networks will have been signaled, a copy is transmitted to the Broadcast Agent.

[0128] Copy To Reporting - A copy of all Broadcasts and Broadcast Requests are written to or stored to the Broadcast Request reporting field that is sent to the reporting subsystem for transmission to the Broadcast Agent Administrator and to the Carrier Broadcast Centers or their reporting subsystem.

[0129] Copy to Logfile - The Broadcast Request is stored in the Logfile and deleted from the pending area as shown in Process 214.

[0130] Admiss Done - An Admiss Done flag or notification is set on the Broadcast Request record along with a timestamp indicating completion of the

ENIT 9834C2

administration process as shown in Process 316. Furthermore, as shown in Process 318, the reporting flag is set, and the method returns to Process 302 for processing of the next Broadcast Record.

[0131] Next Broadcast Agent Parameter - The Next Broadcast Agent parameter is retrieved from the Administration Data Base and compared to the requesting Broadcast Agent as shown in Process 322.

[0132] All Parameters Done - The All Parameters Done process ensures that all parameters have been evaluated and the file processing is near completion as shown in Process 324.

[0133] Fail? - The Fail process determines if a parameter in the Broadcast Request does not meet predefined criteria for a Broadcast Message as defined by the PLBS and/or of the Broadcast Agent Administrator as shown in Process 326.

[0134] Pass Report - If the parameter is within the predefined criteria, the reporting system appends to the Broadcast Request report a short message indicating which parameter has been passed as shown in Process 328. This provides for trouble shooting and resolving disputes. After process 334, the method returns for processing of the next user parameter by Process 322.

[0135] Decline? - If the parameter under test does not fall within the predefined criteria, the parameter fails and special handling procedures are applied as shown in Process 330. Such procedures may enable a system override or an operator override such the Broadcast Request may continue even in light of the parameter within the predefined criteria. Such procedure may include checking the Decline parameter.

[0136] Warning Report - If the Decline Parameter is not met, a warning message is generated and appended to the Broadcast Request as shown in Process 332.

[0137] Warning Flag - A warning flag is set against the particular network as shown in Process 334. After Process 334, the method returns for processing of the next user parameter by Process 322.

[0138] Decline Report - If the Decline parameter indicates that the Broadcast Request is declined, a Decline Report is generated and appended to the Broadcast Request as shown in Process 336.

[0139] Decline Flag - A Decline Flag is set against that network upon indication of a Decline Parameter as shown in Process 338. A Decline Flag may apply to one or more networks as a function of the network facilities or arrangements. After setting this warning flag, the method returns for processing of the next network of Process 312.

[0140] Decline Flag set this Network - When all the parameters have been evaluated, the All Parameters Done message is returned. Prior to sending a Broadcast Request to a Broad Distributor for sending to the particular Carrier and Carrier's network or Carrier Broadcast Center (CBC), a determination of whether the Broadcast Request or message has been declined by the entity or system is determined. If the broadcast message has not been declined for the particular network, then the message is passed on as shown in Process 340.

[0141] Copy to Broadcast Request Distributor - A copy all or the relevant parts of the Broadcast Request is sent to the Broadcast Distributor or placed in a queue as shown in Process 342. The Broadcast Distributor may reformat the data according to one or more predefined parameters, formats or protocol associated with the transmission facility or link for communicating to the Carrier or the Carrier Broadcast Center (CBC).

[0142] Submission Report - A submission date and timestamp are appended to the report, and stored by the BLBS and/or Broadcast Agent Access Device as shown in Process 344. The process returns to the Next Network point so that the next network is evaluated since each network will have network specific criteria and parameters. After process 344, the method returns for processing of the next network by Process 312.

[0143] As shown in Fig. 11 prior to Process 302, using the Broadcast Agent Access Device, a Broadcast Agent defines the target area by drawing shapes or indicating areas on a map to where the broadcast message should be sent. As the target area will likely be served by two or more carriers or telecommunications service providers, the PLBS determines which carriers serve all or a portion of the target area. The PLBS may perform this function by a Broadcast Distributor which may be an integral system or module or a separate standalone system or module. It may be implemented in hardware or software. The Broadcast Distributor routes the broadcast message to the Carrier Broadcast Center (CBC) of the carriers providing service to all or a part of the target area

as defined in the Broadcast Request. This may be implemented in any possible arrangement including a table, chart, or map.

[0144] Operators may in turn have different models of Carrier Broadcast Center (CBC), for example, the GMG 1.5, CellTech, or the Logica 1100, so a different mode of signaling for each type may be provided. One known industry standard protocol is BMSP. Administration data includes routing or address information for the appropriate Carrier Broadcast Center (CBC) interface unit, so that the appropriate signaling protocol conversion occurs.

[0145] Signaling to the CBC may utilize an industry standard BMSP protocol that defines the area polygons in WGS84 co-ordinates, the message, and associated scheduling information. The CBC provides a check of the proposed broadcast message for validity and converts the polygons into a Cell Identification (CellID) list. In one embodiment, the CBC sends the CellID list to the broadcast switching centers (BSC) by standard communication protocol such as the GSM 03.49 protocol/list. Transmission between PLBS-SB and CBC may utilize commercially available systems and facilities that may include TCP/IP secure tunneling protocols, or X25 as demanded by the local carrier.

[0146] When a PLBS Location Selector is provided at the carriers or local carrier's location, the Broadcast Request file may be transmitted by FTP/TCP/IP to the Location Selector for local processing into a Cell ID list before sending to the CBC or the BSC.

[0147] The Administrative Operator utilizes the system to designate administrative and operating parameters and profiles, authorizations, and restrictions for each Broadcast Agent Administrator. These may be based on government regulations, negotiated agreements, standards or policies and practices. This may include establishing schedule of authorizations for various Broadcast Agent Administrators and/or Broadcast Agents.

[0148] The Administrative Operator also establishes within the system an Administration Database to set account parameters so that Broadcast Agent Administrators and their Broadcast Agents have defined authorization levels. The Administrative Operator also uses the system to establish and maintain an account for

each Broadcast Agent and Broadcast Agent Administrator for billing and administration purposes.

[0149] The system is configured to enable the Administrative Operator to resolve review Logfiles and Broadcast Requests. The system enables the Administrative Operator to read the logfiles, and to read and write to the Administration Data Base. The Administrative Operator Management Subsystem is configured to provide the Administrative Operator with a web control panel or GUI environment in which to administer the User account data and system. Additionally the system is configured to generate statistics for administration, management, reporting, and billing.

[0150] A Location Broadcast Reporter may be configured to store broadcast messaging data and to prepare and produce reports related to past, pending, and future broadcast messages in one or more areas. The Location Broadcast Report may be located at a disaster management office, a control room, or the PLBS-SB. Access to such reports and data is made available to authorized personnel of the PLBS operator or an administrative or government entity. Such reports may be made in real-time via a web-based interface such that immediate action may be taken or additional or related actions may be initiated.

[0151] When the Admission Control Subsystem does not accept the Proposed Broadcast Request for any reason, a status message may be sent to the Broadcast Agent Access Device and a Report Required flag may be set. In such a case, reporting obtains the profile from the account data to determine the appropriate procedure.

[0152] Additionally, a notice or dialogue box may be opened at the Broadcast Agent Access Device to report the situation to the Broadcast Agent. If the Broadcast Agent has logged off the Broadcast Agent Access Device, a notification such as an email report is sent to the Broadcast Agent Administrator and the Broadcast Agent according to predefined addresses and arrangements. A copy of the report is also appended to the Broadcast Request to provide a record of the action.

[0153] Reporting also provides for reporting of any activity on the account to the Administrative Operator and Broadcast Agent Administrator. This includes reporting of any warnings that the account may expire. Reporting also sends account information to the Broadcast Agent Administrator on a regular basis depending on parameters defined in

ENIT 9834C2

the account data. Reports are stored in the logfile which may be accessed by the Broadcast Administrative Operator.

[0154] A Broadcast Agent Terminal accessing the Broadcast Agent Portal or Webpage may be located at a Disaster Management Office such as a police control room. The authorized Broadcast Agent creates and proposes the message using a web or internet browser, with web access, public service message location broadcasting system Direct, or the Public Service Location Broadcast Controller (PLBC).

[0155] The Broadcast Agent interacts with the PLBS-SB over a web page, (via a Web Portal); loading of special client software is unnecessary. Almost any computer can use PLBS-SB without any modification at all.

[0156] The Broadcast Agent accesses the Public Service Location Broadcast System (PLBS) via a communication network including the Internet and/or the World Wide Web. The Broadcast Agent device may be any communication device and is preferably one that is configured to access the Internet and/or to host a webpage. This includes a personal computer, laptop computer, mobile phone, and personal administrative device and variations thereof.

[0157] The Broadcast Agent device access a webpage or portal hosted directly or indirectly by the public service message location broadcasting system. Any current or future web, internet, or similar and future services browser or access method may be used by the Broadcast Agent. A standard language such as in one embodiment a Hyper Text Mark-up Language, HTML, may be utilized using any existing or future hardware and/or software platform. Standard, proprietary, and/or commercially available communications systems and protocols may be utilized to provide the various communications facilities and interconnections.

[0158] When added security is desired, commercially available or proprietary effective security protocols and measures such as SSL with public key encryption may be employed along with private networking facilities, Virtual Private Network (VPN) facilities, and/or secure tunneling features.

[0159] A Broadcast Agent Web Portal is made available throughout a LAN or an Internet to provide each and every Broadcast Agent with the flexibility of accessing the Public Service Message Location Broadcast System (PLBS) via any workstation

wherever it may be located, including ones located at a home, remote office, or a portable computing computer, device or platform. The system may utilize wireless LANs such as the 802.11 technology and mobile Internet systems and networks.

[0160] The Broadcast Agent Web Portal is presented as a web page. The Broadcast Agent Webpage may be designed in a design configuration or pattern with an appearance of a control room or panel. Additionally, Broadcast Agent Webpage may be consistent a Geographical Information System (GIS) service portal or webpage.

[0161] The Broadcast Agent Web Portal or Webpage may include or be composed of one or more maps with scroll bars and zoom options for easy and quick map viewing. One or more tool bars provide for Broadcast Agent with the ability to select and define a broadcast target area in a map format. While currently web browsers do not process Geographical Information System (GIS) data, the map may be a jpeg format image or file with conversions for position being performed by the PLBS-SB to aid the browser. However, it is expected that in the future the Broadcast Agent Web Portal or Webpage will directly support GIS map data, displaying, and definitional inputs.

[0162] The Homepage of the Broadcast Agent Webpage may present a map of the demonstration zone and a city or location name associated with the particular geographic area and/or the particular Broad Agent. In an alternative embodiment, the Homepage may display general data available to all users.

[0163] When a Broadcast Agent logs in, a map of the jurisdiction of that Broadcast Agent is displayed. The map is established by the Administrative Operator and/or the Broad Agent Administrator to prevent accidentally sending messages to an unrelated or unauthorized area.

[0164] The Broadcast Agent Web Portal or Webpage are designed to enable the sending or requesting of a Broadcast Request or message within six enters or "clicks" from the Broadcast Agent accessing the Web Portal. Similarly, the system is designed so that such actions are in a timely manner and may be accomplished in 15 seconds.

[0165] The Broadcast Agent utilizing the Broadcast Agent Webpage uses a pointing device such as a mouse or touchpad to define an area for which the message will be broadcast, e.g., the broadcast target area or Broadcast Target Area/Footprint.

Preferably, the broadcast target area is defined by the Broadcast Agent through a graphical selection means such as clicking a mouse on the displayed map.

[0166] After the Broadcast Agent defines the broadcast target area, the Broadcast Agent initiates a message menu button on the menu bar and enters a message such as by typing a text message into a keyboard.

[0167] After this is complete, the Broadcast Agent authenticates the Broadcast Request through one or more authentication procedures. These may include entering a User ID and Password, speaking a voice authentication message, or otherwise. After the Broadcast Request has been authenticated, the Broadcast Request is forwarded to the Public Service Location Broadcast System (PLBS) Service Bureau.

[0168] Optional system features may also be made available to the Broadcast Agent via the Broadcast Agent Web Portal or Webpage. These may be implemented as additional options on an Advanced button or the toolbar. These optional features may include:

[0169] - Broadcast Target Area/Footprint library

[0170] - Message library

[0171] - Multiple language messages

[0172] - Long messages

[0173] - Start time, Stop time

[0174] - Channel codes

[0175] - Recall messages

[0176] - Select networks

[0177] - Progress windows

[0178] The Broadcast Agent Web Portal and Webpage may provide one or more progress windows.

[0179] Once the Broadcast Agent has pressed the GO-button, and accepted liability for the message by typing his User ID and password, the message is not transmitted directly. Instead it is sent to the PLBS-SB's administrations subsystem where the Broadcast Agent is checked out for authority for this message. For example, the message has been defined for transmission within his jurisdiction. There may be

restrictions on how many messages one individual or center may send in a period. This may be defined by the local carriers, government entities, or by the PLBS-SB operator.

[0180] Billing for the service may be done on the basis of the area that was defined for the message, or the population density assumed for the message. In each case the Broadcast Agent may want to know what the message is costing before deciding to proceed.

[0181] The Broadcast Agents request and message are checked over thoroughly by the administration subsystem to make sure of compliance to all agreements, with the Broadcast Agent, the government authorities and the local carriers. Only in the case of full compliance does the message proceed. If so, a dialogue box confirms when each local carrier has accepted the message.

[0182] If not, then the Broadcast Agent will get a dialogue box explaining why the message was declines and a suggestion as to what to do next to get the message sent off quickly. For example, a smaller less ambitious Broadcast Target Area/Footprint may be tried, or perhaps authorization from a higher ranking Broadcast Agent.

[0183] Alternatively, when a web-based interface cannot handle a particular application or situation, the Advanced Broadcast Controller (PLBC) may provide this functionality. This third party application, can call on more, perhaps confidential information to define the broadcast area. In this way the confidential information never leaves the building.

[0184] At the local carrier's office, there is a Carrier Broadcast Center (CBC) server collates the cell Latitude and Longitude data received from the PLBS-SB with the locally provided Cell ID data for that carrier's network. A cell serving area map or table is derived from local carrier planning tool, systems, and data. Typically a carrier's engineering group prepares similar information for planning, maintenance and administration purposes.

[0185] Location broadcast messages are broadcast by the Cellular Network Operators on a per-cell basis over a location broadcast channel. In order to send a location broadcast message, a signal is sent to the Carrier Broadcast Center. From here, to the Base Station Controllers (BSC), containing the message to be transmitted, and

crucially, the Global Cell IDs of the cells in which the broadcast is to be made, along with some other data such as how often and when the message is to be broadcast.

[0186] Cellular operators guard the information about their cells (the cell data) with great care, as the information can be useful to a competitor. They may find the prospect of having this information on multiple unsecured servers to be unacceptable.

[0187] According to one embodiment of the PLBS, each carrier maintains and controls access to their own proprietary network data including cell locations and cell serving areas. Each carrier receives geographic data defining the target area for the public service broadcast and determines which transmissions and transmitting locations relate to the target area. Once established, each carrier initiates message broadcasting to only those locations or areas which relate in whole or in part to the target area. As such, competing carriers do not have access to other carrier's networks or proprietary network or customer data.

[0188] Transmission between PLBS-SB and CBC is achieved with available telecommunication facilities and protocols which may include TCP/IP secure tunneling protocols, security, and authentication. Transmission may be by wireline, wireless, including satellite facilities.

[0189] In one embodiment, the BLBS system ensures that the Carrier's cell data is retained by the Carrier in a look up table in the Carrier Broadcast Center at the Local carrier's office. This includes the Cell Identification Codes of the cells, the Latitude and Longitude positions of their respective Radio Base Station sites and azimuth data for their sectors. This leads to per-cell resolution, but for the first application this may be good enough considering the small size of modern cells, which are typically 1-3 Km across (about 2 miles). The cell data never leaves the Network's office. The local carrier such as a mobile service provider provides the hosting of the cell-broadcast messaging technology, access to the local cell network, and transmission of the cell-broadcast messages to its subscribers. Additionally, the carriers or mobile unit service providers may provide cell-site geographic coverage data either internally or to the PLBS operator to enable the operator GUI interface.

[0190] Location broadcast messages may be employed in several ways when numerous operators or carriers in a particular geographical area require the same

information in a timely manner. Such information may include text messages relating to emergency situations, and, for 3G cells and phones, pictures of wanted or missing persons, graphical data, maps of problem areas including areas to avoid and escape routes.

[0191] Location broadcasting is a function of cellular networks and is defined by the official standardization bodies, such as GSM MoU, (GSM 03.41) UMTS, 3GPP/3GPP2 and IS95 CDMA. Many networks have location broadcast channels defined for their networks which are unused at present for lack of a suitable application.

[0192] There is typically more than one carrier or operator providing service in the same area. There is no co-ordination of cell planning between competing operators, and as such, the Cell layouts and Cell IDs of each are different. In addition, due to constant improvements in telecommunication and cell coverage and capacity, the network design, and size and layout of geographic network systems and cells covering a particular area can be dynamic, e.g., network reconfigurations, cell splits and switch cutovers.

[0193] Also, many networks have a hierarchical network or cell structure system, with overlapping patterns of networks or cells of different sizes, such as Umbrella Cells, Macro Cells, Overlaid cells, Micro Cells and Pico cells. They may also have multiple layers of sub-band structure in different frequency bands such as (850-1900 or 900-1800-2Ghz, with each having different Cell IDs and different base station spacing.

[0194] Multi-network configurations will continue to increase in complexity with the introduction of 3G General Packet Radio Service (GPRS), EDGE, CDMA2000, and UMTS. 3G location broadcast messages will be much more capable, so different Cell ID tables are entered for a plain text version of the broadcast than for a multi-media version.

[0195] A single signal of about 1KB may be used by the Carrier for each transmission area or cell. The transceiver then carries out the repetition of the message for the time required.

[0196] User receiving devices may include mobile or cellular phones, PDA's, PC's, etc. Receiving devices may provide a distinct alert ring-tone that continues until the message is acknowledged by a local user. Such features and functions are dependent on the features and functionality of the various receiving devices. Some receiving

devices may be configured to receive text messages, graphical data, images, and maps or may be capable of connecting to a designated website that provides additional information.

[0197] With one or more embodiments of the current system, special handsets or mobile unit units are not required. Global System for Mobile Communication (GSM) handsets may display a public service message location broadcasting system message as provided by a supporting GSM mobile service provider. Additionally, 3rd Generation mobile unit services providers and mobile unit or cellular devices will display location broadcast messages consistent with the public service message location broadcasting system.

[0198] A public service message location broadcasting service may also display a public service message location broadcasting system provider insignia or service mark.

[0199] Because public service message location broadcasting system is independent of the mobile unit service providers voice and SMS channels, cell-broadcasting will continue to operate during emergencies that result in high calling volume thereby enabling local authorities with a viable communications link for emergency instructions despite interruptions in voice and SMS service.

[0200] In operation, the public service message location broadcasting system may be provided, in one embodiment, by a method described herein. In the event of a need for a public service message broadcast, an authorized Broadcast Agent enters a password to access the public service message location broadcasting system via a Broadcast Agent System accessing a Broadcast Agent Web Portal from an Internet-attached device. The screen recognizes the Broadcast Agent and displays a map or illustration of his jurisdiction.

[0201] The Broadcast Agent defines or selects the target area which may be the entire authorized Broadcast Jurisdiction or may be a portion thereof. The Broadcast Agent constructs a text message indicating the nature of the emergency and/or required action. The Broadcast Agent specifies the length of time the message is to be broadcast and/or received by the receiving devices in the target area. The Broadcast Agent utilizing the Broadcast Agent System confirms and sends the data to the public service message location broadcasting system server.

[0202] The public service message location broadcasting system's Broadcast Data Management (BDM) server reformats the data and forwards it to the Carrier Broadcast Center for each of the telecommunication carriers providing service within the target area.

[0203] The Carriers Broadcast Center (CBC) selects one or more sub-networks and/or cell-sectors (such as transmission towers) that serve all or a portion of the target area so that the entire target area is covered by a broadcast. The CBC broadcast the message to all receiving devices within its serving area. The CBC broadcast transmission process is repeated for the duration of the alert to accommodate additional devices entering, becoming available, or being activated/powering-on within the target area. Receiving devices located within the broadcast sub-networks or cells receive the public service broadcast message, and may provide an alert and display of the message.

[0204] In practice, operation of one or more embodiments may be described by the following example.

[0205] It is late at night and a river level is rising to dangerous levels. The local police want to warn the population at risk, the people who live in the area likely to flood. However since it is night time, they are not watching their televisions or listening to the radio. The senior police officer, or disaster manager, in the position of a Broadcast Agent accesses the public service message location broadcasting system web site that is located at a central site. The officer selects a map of the area that is in danger. The officer defines or selects a geographic broadcast target area to be notified of the danger. The officer enters a message indicating the nature of the danger and suggested actions such as FLOOD WARNING in your area. The officer initiates the broadcast messaging by following a security procedure and presses a Go-button.

[0206] The PLBS-SB receives the messages, performs a check on the validity of the officer as a Broadcast Agent that is proposing the message for the particular notification or broadcast target area. Once validated, the PLBS-SB sends messages to each of the telecommunication service providers or carrier having networks, coverage, or receiving units within the defined coverage area.

[0207] Each local telecommunication service provider receives the message and broadcast target area definitions from the broadcast system and initiates transmission of

ENIT 9834C2

the broadcast message to the particular transmission networks serving the defined notification area. The local network of the telecommunication service provider broadcasts the message to every active compatible receiving unit active within the defined notification area. Each receiving unit receives the broadcast message and displays the message and may provide a common or unique alerting signal.

[0208] When introducing aspects of the disclosure or embodiments thereof, the articles "a", "an", "the", and "said" are intended to mean that there are one or more of the elements. The terms "comprising", "including", and "having" are intended to be inclusive and mean that there may be additional elements other than the listed elements.

[0209] In view of the above, it will be seen that several aspects of the disclosure are achieved and other advantageous results attained. As various changes could be made in the above exemplary constructions and methods without departing from the scope of the disclosure, it is intended that all matter contained in the above description or shown in the accompanying drawings shall be interpreted as illustrative and not in a limiting sense.

[0210] It is further to be understood that the steps described herein are not to be construed as necessarily requiring their performance in the particular order discussed or illustrated. It is also to be understood that additional or alternative steps may be employed.

[0211] Appendix 1: Code channel assignments

500 common training, exercise and test channel.
501-650 Languages listed in order according to ISO 639.
501 aa Afar
502 ab Abkhazian
503 af Afrikaans
504 am Amharic
505 ar Arabic
506 as Assamese
507 ay Aymara
508 az Azerbaijani
509 ba Bashkir
510 be Byelorussian
511 bg Bulgarian
512 bh Bihari
513 bi Bislama
514 bn Bengali, Bangla
515 bo Tibetan
516 br Breton
517 ca Catalan
518 co Corsican
519 cs Czech
520 cy Welsh
521 da Danish
522 de German
523 dz Bhutani
524 el Greek
525 en English
526 eo Esperanto
527 es Spanish
528 et Estonian
529 eu Basque
530 fa Persian
531 fi Finnish
532 fj Fiji
533 fo Faeroese
534 fr French
535 fy Frisian
536 ga Irish
537 gd Scots Gaelic
538 gl Galician
539 gn Guarani

ENIT 9834C2

540 gu Gujarati
541 ha Hausa
542 hi Hindi
543 hr Croatian
544 hu Hungarian
555 hy Armenian
556 ia Interlingua
557 ie Interlingue
558 ik Inupiak
559 in Indonesian
560 is Icelandic
561 it Italian
562 iw Hebrew
563 ja Japanese
564 ji Yiddish
565 jw Javanese
566 ka Georgian
567 kk Kazakh
568 kl Greenlandic
569 km Cambodian
570 kn Kannada
571 ko Korean
572 ks Kashmiri
573 ku Kurdish
574 ky Kirghiz
575 la Latin
576 ln Lingala
577 lo Laothian
578 lt Lithuanian
579 lv Latvian, Lettish
580 mg Malagasy
581 mi Maori
582 mk Macedonian
583 ml Malayalam
584 mn Mongolian
585 mo Moldavian
586 mr Marathi
587 ms Malay
588 mt Maltese
589 my Burmese
590 na Nauru
591 ne Nepali
592 nl Dutch
593 no Norwegian
594 oc Occitan

ENIT 9834C2

595 om (Afan) Oromo
596 or Oriya
597 pa Punjabi
598 pl Polish
599 ps Pashto, Pushto
600 pt Portuguese
601 qu Quechua
602 rm Rhaeto-Romance
603 rn Kirundi
604 ro Romanian
605 ru Russian
606 rw Kinyarwanda
607 sa Sanskrit
608 sd Sindhi
609 sg Sangro
610 sh Serbo-Croatian
611 si Singhalese
612 sk Slovak
613 sl Slovenian
614 sm Samoan
615 sn Shona
616 so Somali
617 sq Albanian
618 sr Serbian
619 ss Siswati
620 st Sesotho
621 su Sundanese
622 sv Swedish
623 sw Swahili
624 ta Tamil
625 te Tegulu
626 tg Tajik
627 th Thai
628 ti Tigrinya
629 tk Turkmen
630 tl Tagalog
631 tn Setswana
632 to Tonga
633 tr Turkish
634 ts Tsonga
635 tt Tatar
636 tw Twi
637 uk Ukrainian
638 ur Urdu
639 uz Uzbek

ENIT 9834C2

640 vi Vietnamese
641 vo Volapuk
642 wo Wolof
643 xh Xhosa
644 yo Yoruba
645 zh Chinese
646 zu Zulu
646-669 locally specified purpose or language.
670-699 International alert channels.
671 Maritime service channel.
672 Aeronautical service channels.
673 Amateur service channels.
674 Scientific services.
690-699 UN and International Organisations. E.G.
690 UNSECORD (UN Security Co-Ordinator.)
691 UNICEF (Child security)
692 WFP
693 WHO
694 UNHCR
695 OCHA
696 Red Cross/ Crescent Movement.

[0212] Other channels at the discretion of the networks, and in conjunction with the governmental authorities and other interested parties.

CLAIMS

What is claimed is:

1. A message alert broadcast broker system for providing a broadcast message to a plurality of user devices located within a geographically defined broadcast target area, the system comprising:

a broadcast service bureau communicatively coupled for receiving from one of a plurality of coupled broadcast agent access systems providing a broadcast request from an originating broadcast agent associated one broadcast agent message origination systems, the broadcast request including a broadcast agent identification, the geographically defined broadcast target area, and a broadcast message, the broadcast service bureau configured for verifying the broadcast request as a function of the broadcast agent identification including an authority of the originating broadcast agent to send the broadcast message to the broadcast target area,

the broadcast service bureau processing the verified broadcast request for transmission to one or more broadcast message networks providing broadcast message alerting service to at least a portion of the broadcast target area.

2. The system of claim 1 wherein the broadcast service bureau is configured for receiving the broadcast request, and identifying the one or more broadcast message networks providing message alerting service to at least a portion of the broadcast target area.

3. The system of claim 2 wherein the one or more message broadcast message networks includes at least one selected from the group consisting of wireless mobile carrier network, wireless Wi-Fi network, digital private radio systems operator network, private radio system network, internet service provider networks, wireline telecommunication network, satellite network, CATV network, radio system, and television system.

4. The system of claim 1 wherein the broadcast service bureau further includes a distributor receiving the broadcast message and broadcast target area and mapping the broadcast target area to determine which one or more of the broadcast message networks from among a plurality of broadcast message networks has a broadcast message distribution system serving at least a portion of the broadcast target area, and wherein the distributor identifies the one or more broadcast message networks.

5. The system of claim 4 wherein the one or more message broadcast message networks includes at least one selected from the group consisting of wireless mobile carrier network, wireless Wi-Fi network, digital private radio systems operator network, private radio system network, internet service provider networks, wireline telecommunication network, satellite network, CATV network, radio system, and television system.

6. The system of claim 1 wherein the broadcast service bureau includes an output interface for coupling to one of the one or more broadcast message networks providing message alerting service to at least a portion of the broadcast target area.

7. The system of claim 6 wherein the output interface is configured to interface with a message broadcast message network selected from the group consisting of wireless mobile carrier network, wireless Wi-Fi network, digital private radio systems operator network, private radio system network, internet service provider networks, wireline telecommunication network, satellite network, CATV network, radio system, and television system.

8. The system of claim 1 wherein the broadcast service bureau verifies an authority of the broadcast agent to transmit the broadcast message to the broadcast target area as a function of a broadcast message jurisdiction stored in the broadcast service bureau for the originating broadcast agent, the verifying ensuring that the broadcast message jurisdiction of the originating broadcast agent includes the broadcast target area.

9. The system of claim 6 wherein the output interface is configured for interfacing with a carrier broadcast center of a wireless mobile carrier network, the carrier broadcast center converting the broadcast target area to network addresses of wireless transmission devices serving the broadcast target area including determining particular wireless network transmission devices serving at least a portion of the broadcast target area, and identifying the network addresses for each determined particular wireless transmission device and transmitting the broadcast message to the network addresses of the particular wireless transmission devices for wireless transmission by the particular wireless transmission devices to user receiving devices.

10. The system of claim 9 wherein the wireless transmission devices serving the broadcast target area and the particular wireless transmission devices are wireless cellular network transmitters and each of the wireless cellular network transmitters has a cell id network address and the identified network addresses are cell id network addresses.

11. The system of claim 9 wherein the wireless transmission devices serving the broadcast target area and the particular wireless transmission devices are Wi-Fi network transmitters, each of the Wi-Fi network transmitters having a Wi-Fi id network address, wherein the identified network addresses are Wi-Fi id network addresses.

12. The system of claim 1 wherein the broadcast request includes a message type identifying the type of message of the broadcast message request.

13. The system of claim 1 wherein the broadcast request includes a broadcast message that is an alerting system administrative message selected from the group consisting of:
message recall, language identifier, network selector, and request for message progress status.

14. The system of claim 1 wherein the broadcast message of the broadcast request is a first broadcast message, the first broadcast message being in a first language, and wherein the broadcast request includes a second broadcast message in a second language, and wherein the broadcast service bureau is configured to transmit the broadcast request including at least one of the first broadcast message in the first language and the second broadcast message in the second language.

15. The system of claim 1 wherein the broadcast message is a multimedia message.

16. The system of claim 15 wherein the multimedia message includes at least one of a photograph and a map.

17. The system of claim 1 wherein the broadcast request includes a message type.

18. The system of claim 17 wherein the broadcast service bureau is coupled to a plurality of broadcast message networks, and is configured to select the one or more broadcast message networks from among the plurality of coupled broadcast message networks responsive to at least of the message type and the broadcast target area.

19. A method of public service broadcast messaging to a broadcast target area, the method comprising:

receiving over an input interface a broadcast request including a broadcast agent identification, a geographically defined broadcast target area, and a broadcast message from one of a plurality of coupled broadcast agent message origination systems;

verifying an authority of the broadcast agent identification including an authority of the originating broadcast agent to send the broadcast message to the broadcast target area; and

ENIT 9834C2

transmitting the broadcast message over an output interface to one or more coupled broadcast message networks providing broadcast message alerting service to at least a portion of the broadcast target area.

20. The method of claim 19 wherein the broadcast request includes a message type, further comprising:

selecting the one or more broadcast message networks from among the plurality of coupled broadcast message networks responsive to at least of the message type and the broadcast target area.

ABSTRACT

A message processing system and method for providing a broadcast message to a plurality of user devices located within a geographically defined broadcast target area, the system including a broadcast service bureau communicatively coupled for receiving from one of a plurality of coupled broadcast agent access systems providing a broadcast request from an originating broadcast agent associated one broadcast agent message origination systems. The received broadcast request includes a broadcast agent identification, the geographically defined broadcast target area, and a broadcast message, the broadcast service bureau configured for verifying the broadcast request as a function of the broadcast agent identification including an authority of the originating broadcast agent to send the broadcast message to the broadcast target area. The broadcast service bureau processing the verified broadcast request for transmission to one or more broadcast message networks providing broadcast message alerting service to at least a portion of the broadcast target area.

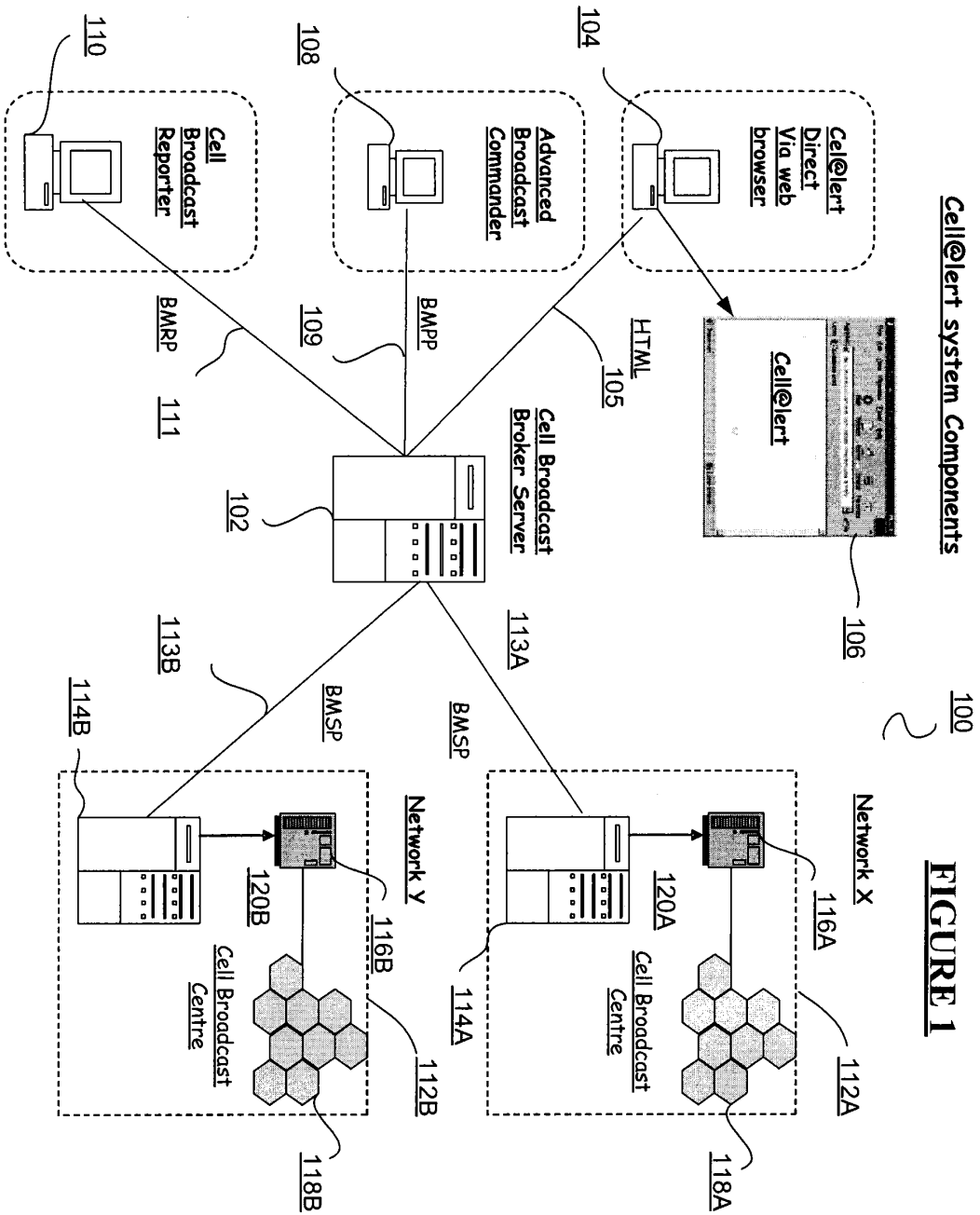

Cell@lert system Components

FIGURE 1

200

FIGURE 2

Cell Broadcast Broker V2, (CBE)

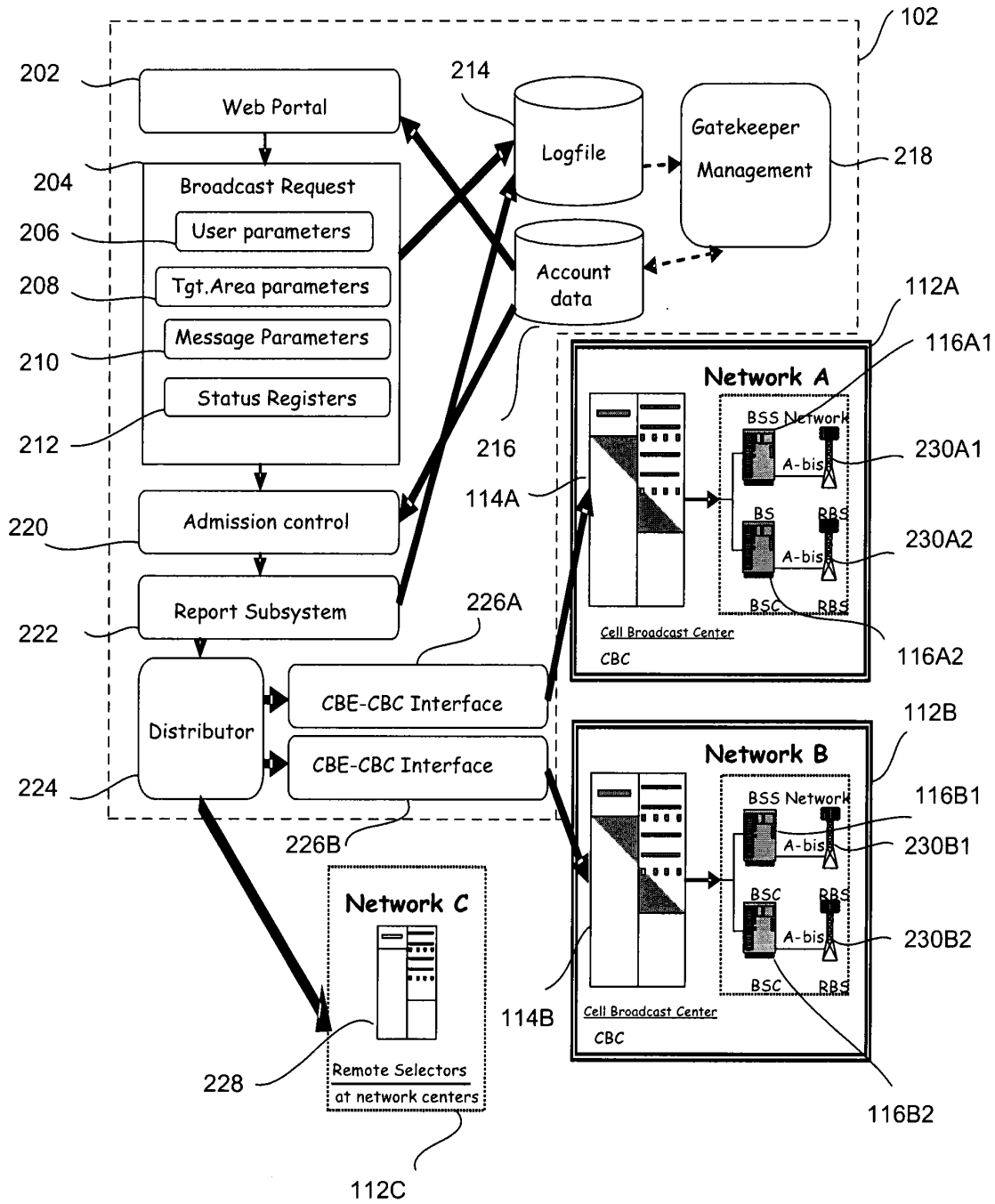

300

FIGURE 3

CBB Admission Control Algorithm

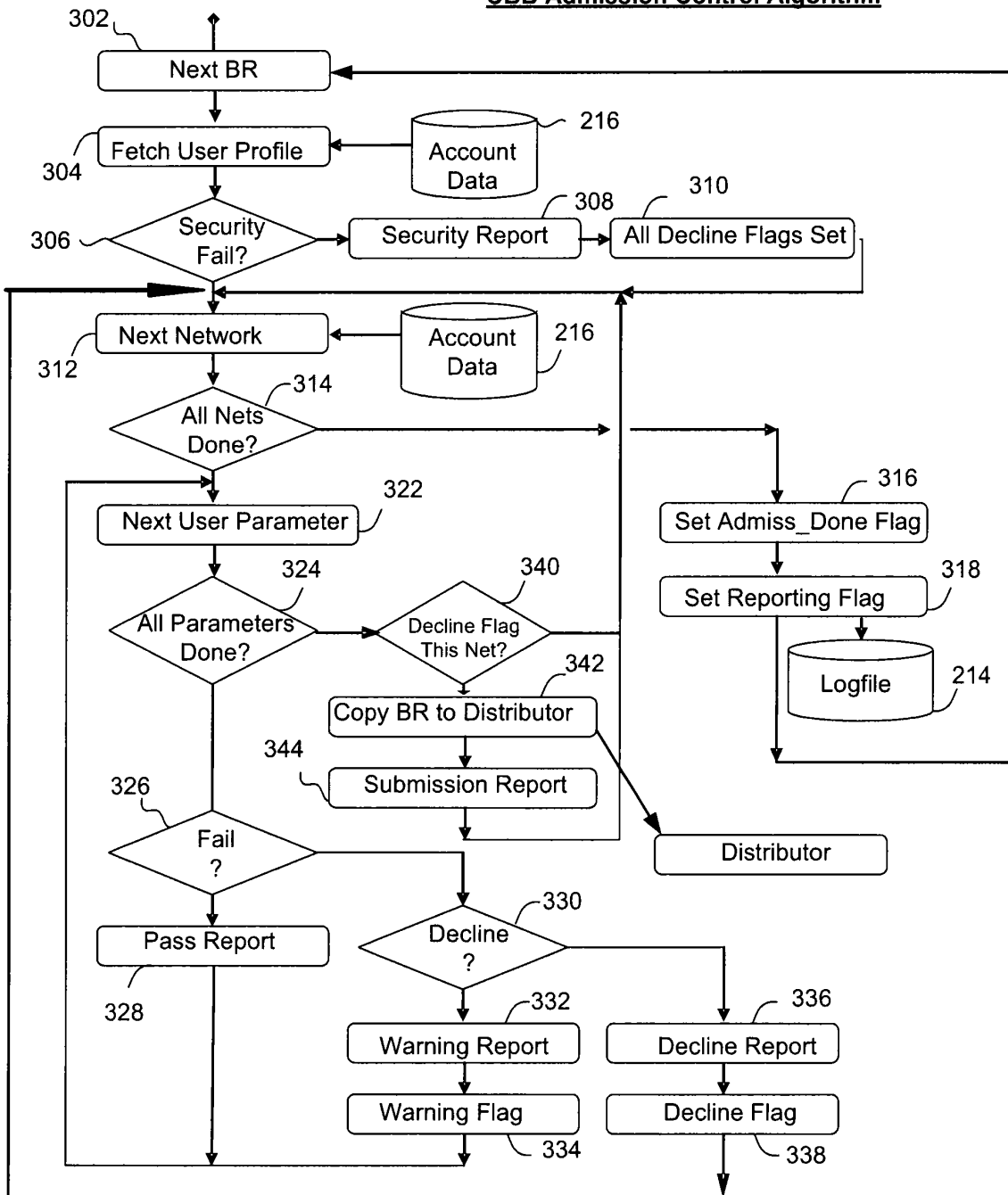

[EDIT TARGET](#)
[NEW TARGET](#)
[NEW MESSAGE](#)
[EDIT MESSAGE](#)
[MESSAGE STATUS](#)
[SEND](#)
[CANCEL](#)
[LOGIN](#)
[HELP](#)



FIGURE 4

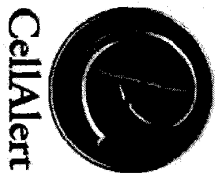
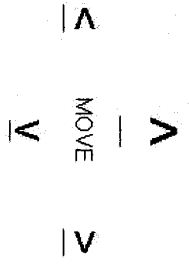
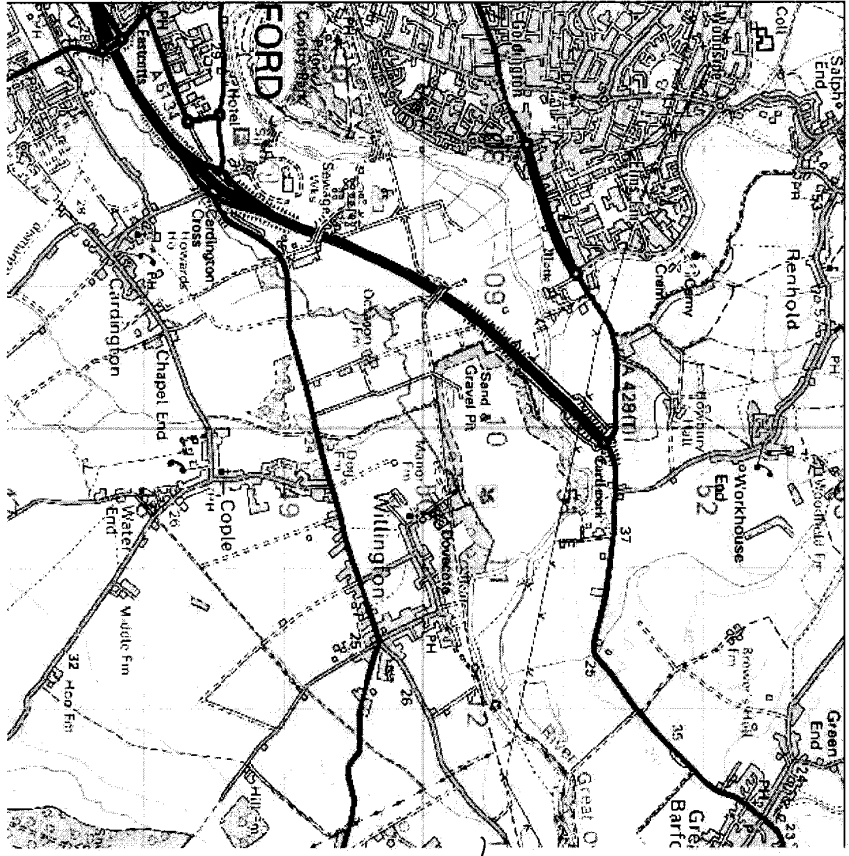

402

404

400

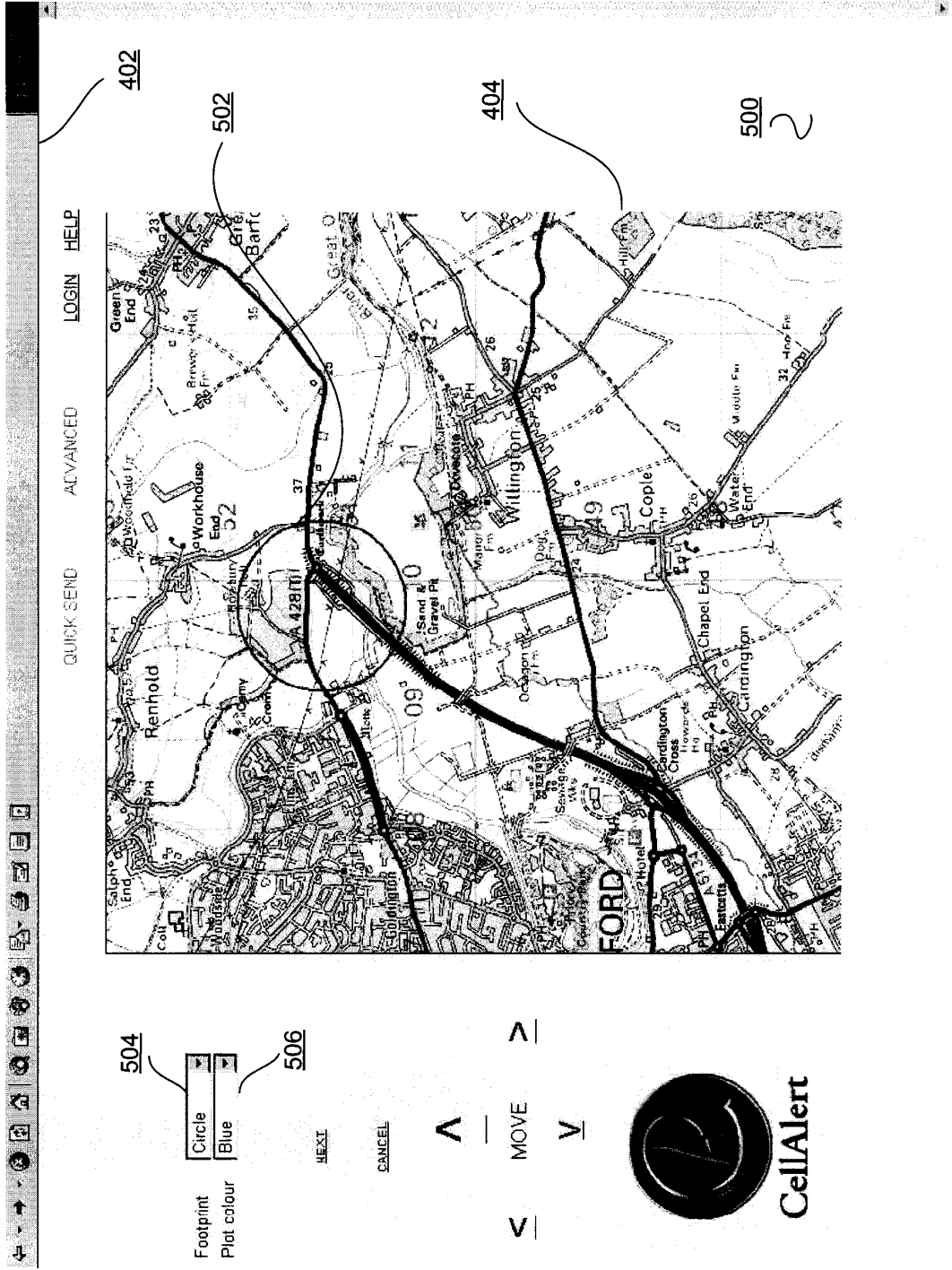

FIGURE 5

402

604

608

404

600

2

402

604

608

404

600

2

QUICK SEND ADVANCED LOGIN HELP

Salph End Renhold Workhouse End Green End Gt. Bartc

Willington Chapel End Carrington

FORD

602

506

Footprint

Plot colour

Shape

Blue

NEXT

CANCEL

^

MOVE

V

CellAlert

FIGURE 6

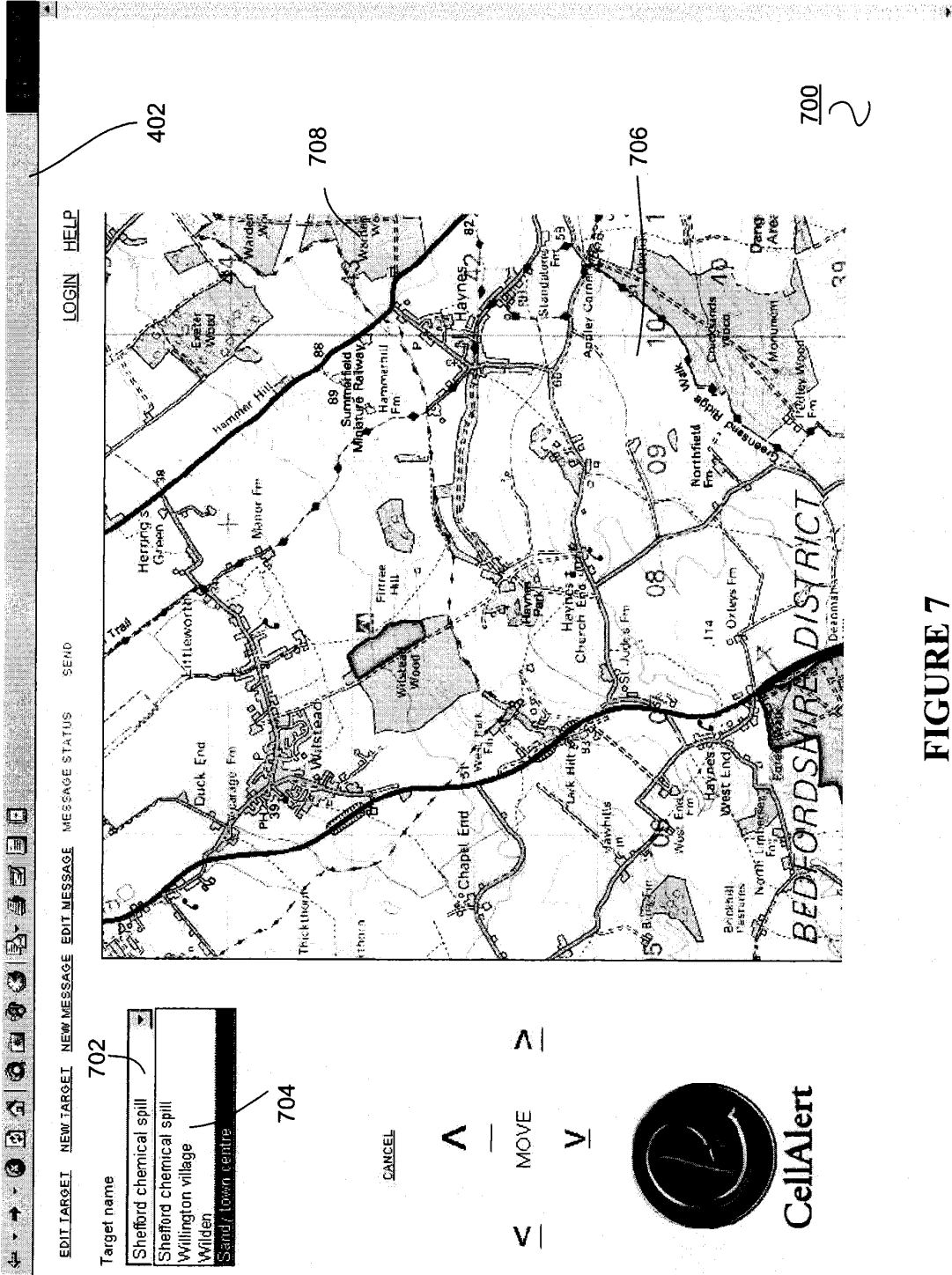

FIGURE 7

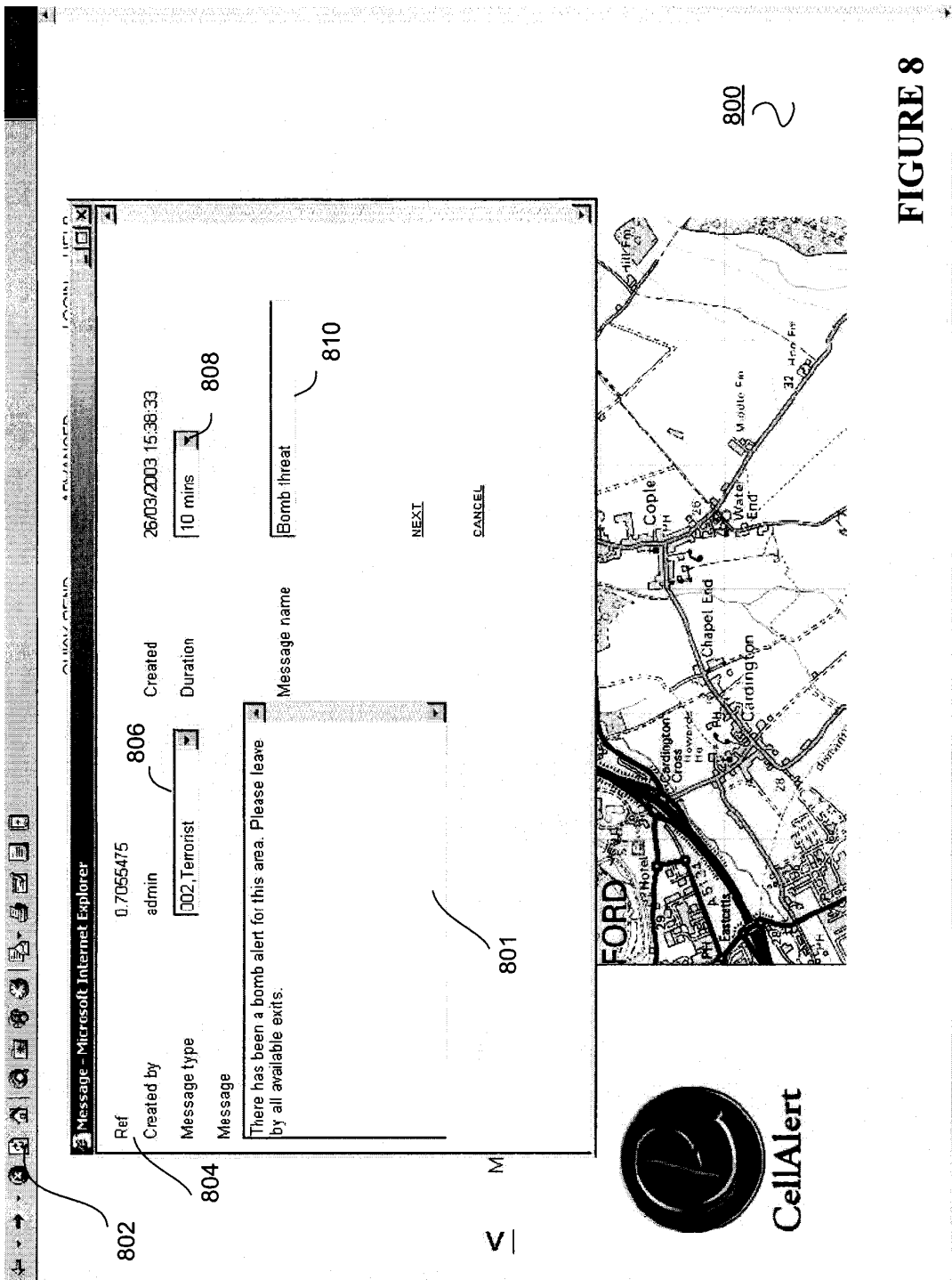

FIGURE 8

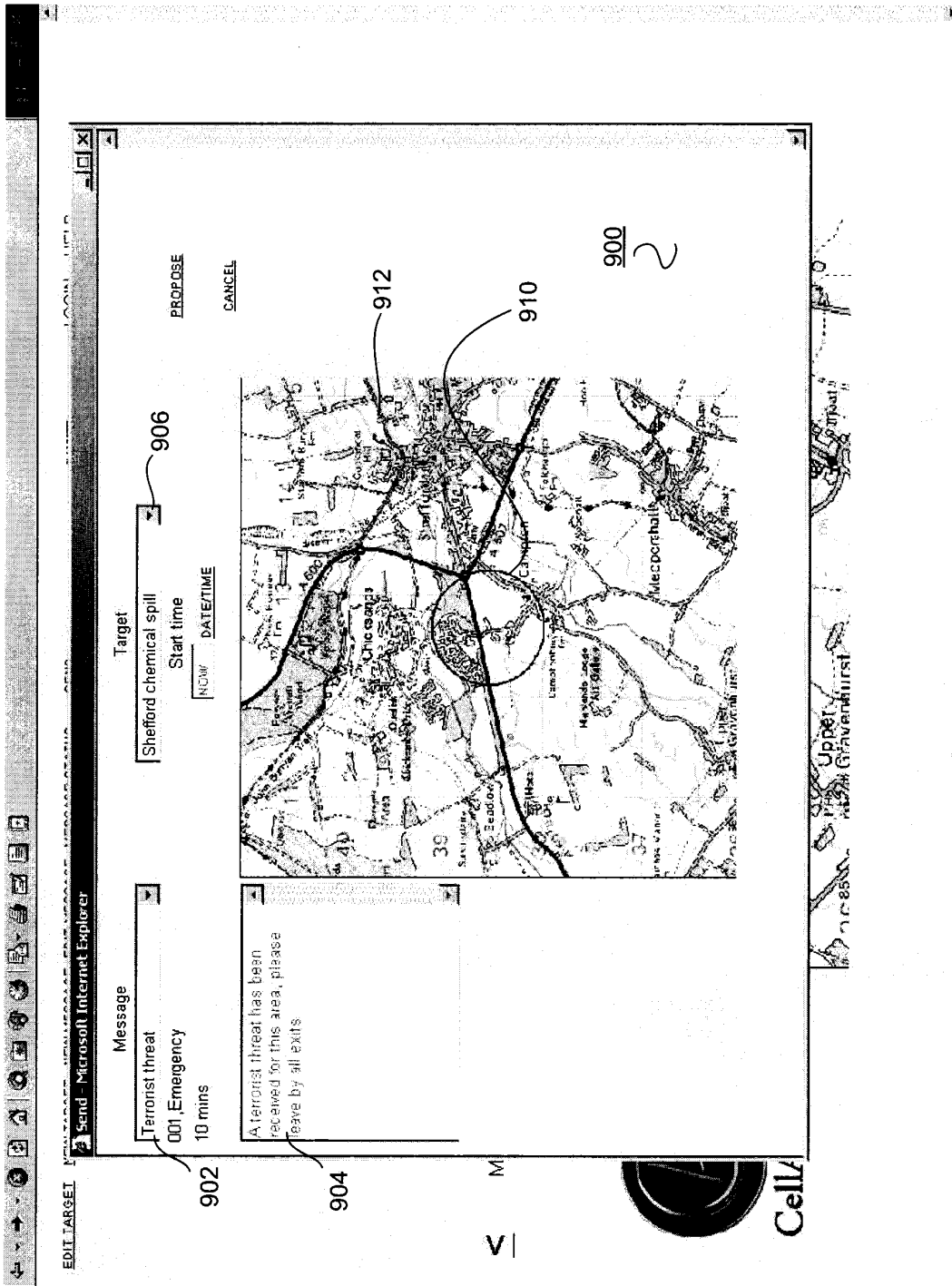

FIGURE 9

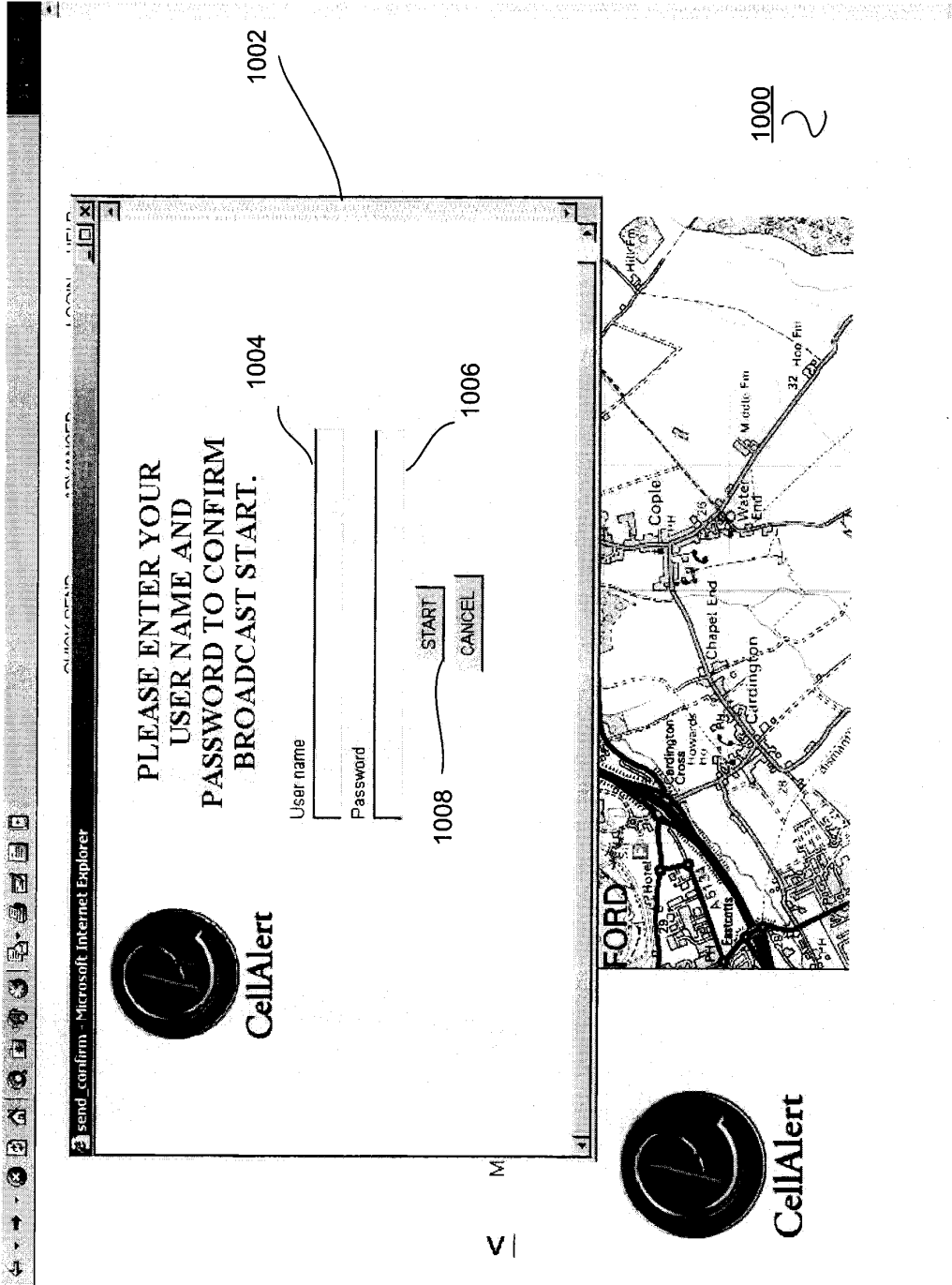
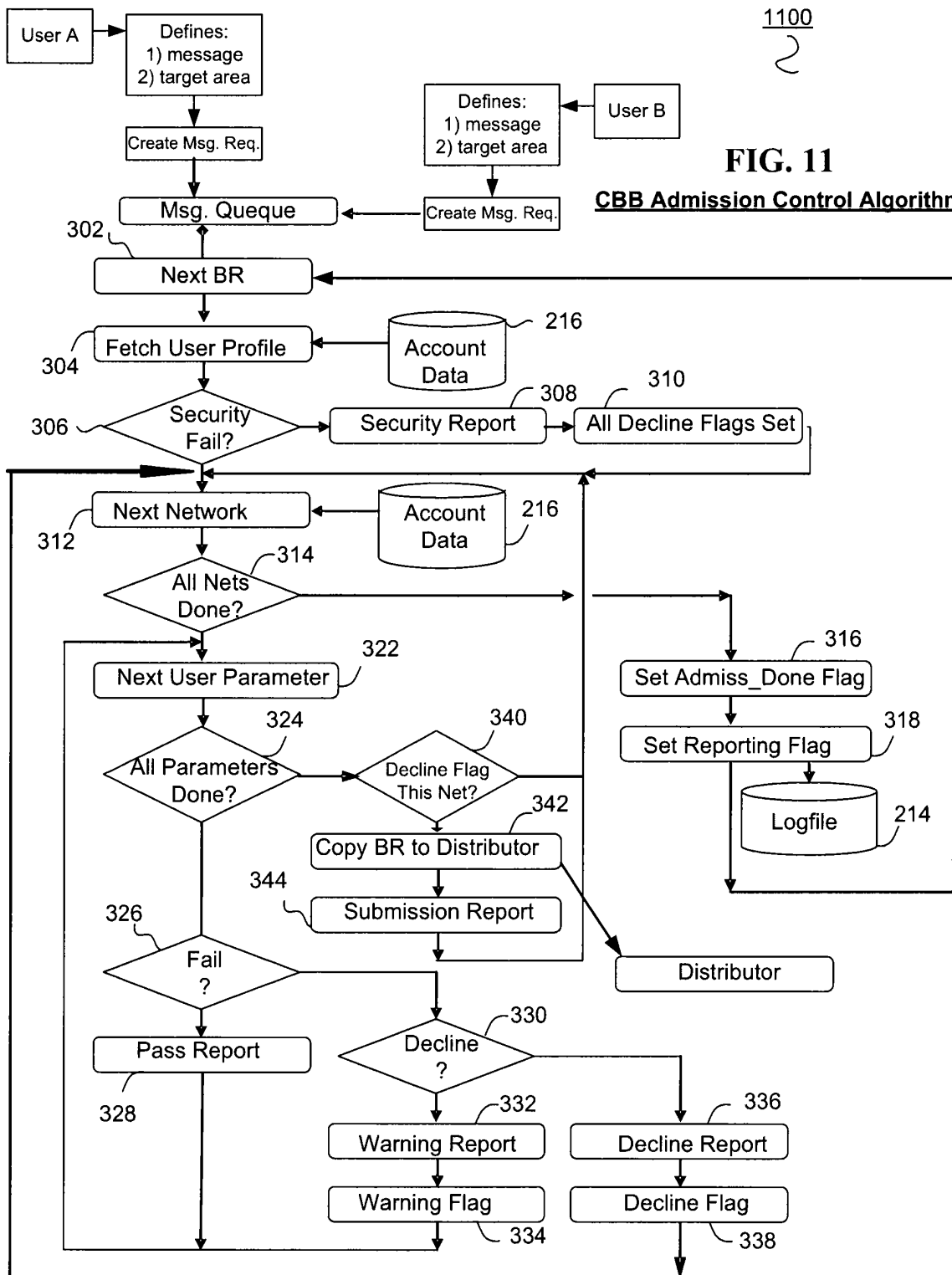

FIGURE 10



PATENT APPLICATION FEE DETERMINATION RECORD

Substitute for Form PTO-875

Application or Docket Number
13/311,448

APPLICATION AS FILED - PART I

(Column 1)		(Column 2)	SMALL ENTITY		OR	OTHER THAN SMALL ENTITY	
FOR	NUMBER FILED	NUMBER EXTRA	RATE(\$)	FEE(\$)		RATE(\$)	FEE(\$)
BASIC FEE (37 CFR 1.16(a), (b), or (c))	N/A	N/A	N/A	95		N/A	
SEARCH FEE (37 CFR 1.16(k), (l), or (m))	N/A	N/A	N/A	310		N/A	
EXAMINATION FEE (37 CFR 1.16(o), (p), or (q))	N/A	N/A	N/A	125		N/A	
TOTAL CLAIMS (37 CFR 1.16(i))	20 minus 20 =	*	x 30 =	0.00	OR		
INDEPENDENT CLAIMS (37 CFR 1.16(h))	2 minus 3 =	*	x 125 =	0.00			
APPLICATION SIZE FEE (37 CFR 1.16(s))	If the specification and drawings exceed 100 sheets of paper, the application size fee due is \$310 (\$155 for small entity) for each additional 50 sheets or fraction thereof. See 35 U.S.C. 41(a)(1)(G) and 37 CFR 1.16(s).			0.00			
MULTIPLE DEPENDENT CLAIM PRESENT (37 CFR 1.16(j))				0.00			
* If the difference in column 1 is less than zero, enter "0" in column 2.			TOTAL	530		TOTAL	

APPLICATION AS AMENDED - PART II

AMENDMENT A	(Column 1)		(Column 2)	(Column 3)	SMALL ENTITY		OR	OTHER THAN SMALL ENTITY	
	CLAIMS REMAINING AFTER AMENDMENT		HIGHEST NUMBER PREVIOUSLY PAID FOR	PRESENT EXTRA	RATE(\$)	ADDITIONAL FEE(\$)		RATE(\$)	ADDITIONAL FEE(\$)
Total (37 CFR 1.16(i))	*	Minus	**	=	x	=	OR	x	=
Independent (37 CFR 1.16(h))	*	Minus	***	=	x	=	OR	x	=
Application Size Fee (37 CFR 1.16(s))							OR		
FIRST PRESENTATION OF MULTIPLE DEPENDENT CLAIM (37 CFR 1.16(j))							OR		
					TOTAL ADD'L FEE		OR	TOTAL ADD'L FEE	

AMENDMENT B	(Column 1)		(Column 2)	(Column 3)	SMALL ENTITY		OR	OTHER THAN SMALL ENTITY	
	CLAIMS REMAINING AFTER AMENDMENT		HIGHEST NUMBER PREVIOUSLY PAID FOR	PRESENT EXTRA	RATE(\$)	ADDITIONAL FEE(\$)		RATE(\$)	ADDITIONAL FEE(\$)
Total (37 CFR 1.16(i))	*	Minus	**	=	x	=	OR	x	=
Independent (37 CFR 1.16(h))	*	Minus	***	=	x	=	OR	x	=
Application Size Fee (37 CFR 1.16(s))							OR		
FIRST PRESENTATION OF MULTIPLE DEPENDENT CLAIM (37 CFR 1.16(j))							OR		
					TOTAL ADD'L FEE		OR	TOTAL ADD'L FEE	

* If the entry in column 1 is less than the entry in column 2, write "0" in column 3.
 ** If the "Highest Number Previously Paid For" IN THIS SPACE is less than 20, enter "20".
 *** If the "Highest Number Previously Paid For" IN THIS SPACE is less than 3, enter "3".
 The "Highest Number Previously Paid For" (Total or Independent) is the highest found in the appropriate box in column 1.



UNITED STATES PATENT AND TRADEMARK OFFICE

UNITED STATES DEPARTMENT OF COMMERCE
United States Patent and Trademark Office
Address: COMMISSIONER FOR PATENTS
P.O. Box 1450
Alexandria, Virginia 22313-1450
www.uspto.gov

Table with 7 columns: APPLICATION NUMBER, FILING or 371(c) DATE, GRP ART UNIT, FIL FEE REC'D, ATTY.DOCKET.NO, TOT CLAIMS, IND CLAIMS. Row 1: 13/311,448, 12/05/2011, 2617, 530, ENIT 9834C2, 20, 2

CONFIRMATION NO. 9039

FILING RECEIPT

1688
Polster, Lieder, Woodruff & Lucchesi, L.C.
12412 Powerscourt Dr. Suite 200
St. Louis, MO 63131-3615



Date Mailed: 12/21/2011

Receipt is acknowledged of this non-provisional patent application. The application will be taken up for examination in due course. Applicant will be notified as to the results of the examination. Any correspondence concerning the application must include the following identification information: the U.S. APPLICATION NUMBER, FILING DATE, NAME OF APPLICANT, and TITLE OF INVENTION. Fees transmitted by check or draft are subject to collection. Please verify the accuracy of the data presented on this receipt. If an error is noted on this Filing Receipt, please submit a written request for a Filing Receipt Correction. Please provide a copy of this Filing Receipt with the changes noted thereon. If you received a "Notice to File Missing Parts" for this application, please submit any corrections to this Filing Receipt with your reply to the Notice. When the USPTO processes the reply to the Notice, the USPTO will generate another Filing Receipt incorporating the requested corrections

Applicant(s)

Mark Andrew Wood, Haslemere, UNITED KINGDOM;
Kevin Russell Preston, Gwent, UNITED KINGDOM;
Douglas Weiser, Port Richey, FL;

Assignment For Published Patent Application

ENVISIONIT LLC, St. Charles, MO

Power of Attorney: None

Domestic Priority data as claimed by applicant

This application is a CON of 12/559,405 09/14/2009 PAT 8073903
which is a CON of 11/057,704 02/14/2005 PAT 7752259
which claims benefit of 60/544,739 02/13/2004

Foreign Applications (You may be eligible to benefit from the Patent Prosecution Highway program at the USPTO. Please see http://www.uspto.gov for more information.)

If Required, Foreign Filing License Granted: 12/16/2011

The country code and number of your priority application, to be used for filing abroad under the Paris Convention, is US 13/311,448

Projected Publication Date: To Be Determined - pending completion of Missing Parts

Non-Publication Request: No

Early Publication Request: No

** SMALL ENTITY **

Title

BROADCAST ALERTING MESSAGE AGGREGATOR/GATEWAY SYSTEM AND METHOD

Preliminary Class

455

PROTECTING YOUR INVENTION OUTSIDE THE UNITED STATES

Since the rights granted by a U.S. patent extend only throughout the territory of the United States and have no effect in a foreign country, an inventor who wishes patent protection in another country must apply for a patent in a specific country or in regional patent offices. Applicants may wish to consider the filing of an international application under the Patent Cooperation Treaty (PCT). An international (PCT) application generally has the same effect as a regular national patent application in each PCT-member country. The PCT process **simplifies** the filing of patent applications on the same invention in member countries, but **does not result** in a grant of "an international patent" and does not eliminate the need of applicants to file additional documents and fees in countries where patent protection is desired.

Almost every country has its own patent law, and a person desiring a patent in a particular country must make an application for patent in that country in accordance with its particular laws. Since the laws of many countries differ in various respects from the patent law of the United States, applicants are advised to seek guidance from specific foreign countries to ensure that patent rights are not lost prematurely.

Applicants also are advised that in the case of inventions made in the United States, the Director of the USPTO must issue a license before applicants can apply for a patent in a foreign country. The filing of a U.S. patent application serves as a request for a foreign filing license. The application's filing receipt contains further information and guidance as to the status of applicant's license for foreign filing.

Applicants may wish to consult the USPTO booklet, "General Information Concerning Patents" (specifically, the section entitled "Treaties and Foreign Patents") for more information on timeframes and deadlines for filing foreign patent applications. The guide is available either by contacting the USPTO Contact Center at 800-786-9199, or it can be viewed on the USPTO website at <http://www.uspto.gov/web/offices/pac/doc/general/index.html>.

For information on preventing theft of your intellectual property (patents, trademarks and copyrights), you may wish to consult the U.S. Government website, <http://www.stopfakes.gov>. Part of a Department of Commerce initiative, this website includes self-help "toolkits" giving innovators guidance on how to protect intellectual property in specific countries such as China, Korea and Mexico. For questions regarding patent enforcement issues, applicants may call the U.S. Government hotline at 1-866-999-HALT (1-866-999-4158).

LICENSE FOR FOREIGN FILING UNDER**Title 35, United States Code, Section 184****Title 37, Code of Federal Regulations, 5.11 & 5.15****GRANTED**

The applicant has been granted a license under 35 U.S.C. 184, if the phrase "IF REQUIRED, FOREIGN FILING LICENSE GRANTED" followed by a date appears on this form. Such licenses are issued in all applications where the conditions for issuance of a license have been met, regardless of whether or not a license may be required as

page 2 of 3

set forth in 37 CFR 5.15. The scope and limitations of this license are set forth in 37 CFR 5.15(a) unless an earlier license has been issued under 37 CFR 5.15(b). The license is subject to revocation upon written notification. The date indicated is the effective date of the license, unless an earlier license of similar scope has been granted under 37 CFR 5.13 or 5.14.

This license is to be retained by the licensee and may be used at any time on or after the effective date thereof unless it is revoked. This license is automatically transferred to any related applications(s) filed under 37 CFR 1.53(d). This license is not retroactive.

The grant of a license does not in any way lessen the responsibility of a licensee for the security of the subject matter as imposed by any Government contract or the provisions of existing laws relating to espionage and the national security or the export of technical data. Licensees should apprise themselves of current regulations especially with respect to certain countries, of other agencies, particularly the Office of Defense Trade Controls, Department of State (with respect to Arms, Munitions and Implements of War (22 CFR 121-128)); the Bureau of Industry and Security, Department of Commerce (15 CFR parts 730-774); the Office of Foreign Assets Control, Department of Treasury (31 CFR Parts 500+) and the Department of Energy.

NOT GRANTED

No license under 35 U.S.C. 184 has been granted at this time, if the phrase "IF REQUIRED, FOREIGN FILING LICENSE GRANTED" DOES NOT appear on this form. Applicant may still petition for a license under 37 CFR 5.12, if a license is desired before the expiration of 6 months from the filing date of the application. If 6 months has lapsed from the filing date of this application and the licensee has not received any indication of a secrecy order under 35 U.S.C. 181, the licensee may foreign file the application pursuant to 37 CFR 5.15(b).

SelectUSA

The United States represents the largest, most dynamic marketplace in the world and is an unparalleled location for business investment, innovation and commercialization of new technologies. The USA offers tremendous resources and advantages for those who invest and manufacture goods here. Through SelectUSA, our nation works to encourage, facilitate, and accelerate business investment. To learn more about why the USA is the best country in the world to develop technology, manufacture products, and grow your business, visit SelectUSA.gov.



UNITED STATES PATENT AND TRADEMARK OFFICE

UNITED STATES DEPARTMENT OF COMMERCE
United States Patent and Trademark Office
Address: COMMISSIONER FOR PATENTS
P.O. Box 1450
Alexandria, Virginia 22313-1450
www.uspto.gov

Table with 4 columns: APPLICATION NUMBER (13/311,448), FILING OR 371(C) DATE (12/05/2011), FIRST NAMED APPLICANT (Mark Andrew Wood), ATTY. DOCKET NO./TITLE (ENIT 9834C2)

CONFIRMATION NO. 9039

FORMALITIES LETTER

1688
Polster, Lieder, Woodruff & Lucchesi, L.C.
12412 Powerscourt Dr. Suite 200
St. Louis, MO 63131-3615



Date Mailed: 12/21/2011

NOTICE TO FILE MISSING PARTS OF NONPROVISIONAL APPLICATION

FILED UNDER 37 CFR 1.53(b)

Filing Date Granted

Items Required To Avoid Abandonment:

An application number and filing date have been accorded to this application. The item(s) indicated below, however, are missing. Applicant is given TWO MONTHS from the date of this Notice within which to file all required items below to avoid abandonment. Extensions of time may be obtained by filing a petition accompanied by the extension fee under the provisions of 37 CFR 1.136(a).

- The oath or declaration is missing.
A properly signed oath or declaration in compliance with 37 CFR 1.63, identifying the application by the above Application Number and Filing Date, is required.
Note: If a petition under 37 CFR 1.47 is being filed, an oath or declaration in compliance with 37 CFR 1.63 signed by all available joint inventors, or if no inventor is available by a party with sufficient proprietary interest, is required.

The application is informal since it does not comply with the regulations for the reason(s) indicated below.

The required item(s) identified below must be timely submitted to avoid abandonment:

- A replacement abstract not exceeding 150 words in length and commencing on a separate sheet in compliance with 37 CFR 1.72(b) and 37 CFR 1.121 is required.

Applicant is cautioned that correction of the above items may cause the specification and drawings page count to exceed 100 pages. If the specification and drawings exceed 100 pages, applicant will need to submit the required application size fee.

The applicant needs to satisfy supplemental fees problems indicated below.

The required item(s) identified below must be timely submitted to avoid abandonment:

- A surcharge (for late submission of filing fee, search fee, examination fee or oath or declaration) as set forth in 37 CFR 1.16(f) of \$65 for a small entity in compliance with 37 CFR 1.27, must be submitted.

SUMMARY OF FEES DUE:

Total fee(s) required within TWO MONTHS from the date of this Notice is \$65 for a small entity

- \$65 Surcharge.

Replies should be mailed to:

Mail Stop Missing Parts
Commissioner for Patents
P.O. Box 1450
Alexandria VA 22313-1450

Registered users of EFS-Web may alternatively submit their reply to this notice via EFS-Web.
<https://sportal.uspto.gov/authenticate/AuthenticateUserLocalEPF.html>

For more information about EFS-Web please call the USPTO Electronic Business Center at **1-866-217-9197** or visit our website at <http://www.uspto.gov/ebc>.

If you are not using EFS-Web to submit your reply, you must include a copy of this notice.

/bmnnguyen/

Office of Data Management, Application Assistance Unit (571) 272-4000, or (571) 272-4200, or 1-888-786-0101

PATENT

IN THE UNITED STATES PATENT AND TRADEMARK OFFICE

Applicant: Wood, et al :
 : Art Unit: TBD
Application No: 13/311,448 :
 : Examiner: TBD
Filed: 12/05/11 :
 :
For: : Attorney Docket No: ENIT 9834C2
 BROADCAST ALERTING
 MESSAGE AGGREGATOR/
 GATEWAY SYSTEM AND
 METHOD

Mail Stop Amendment
Commissioner for Patents
P.O. Box 1450
Alexandria, Virginia 22313-1450

PRELIMINARY AMENDMENT RESPONSE TO MISSING PARTS

Sir:

In response to the Notice of Missing Part of December 21, 2011, please amend the application as follows and consider the remarks set forth below.

Amendments to the Specification begin on page 2 of this paper.

Remarks begin on page 3 of this paper.

AMENDMENTS TO THE SPECIFICATION

Please replace the Abstract with the following paragraph rewritten in amendment format:

A message processing system and method for providing a broadcast message to a plurality of user devices located within a geographically defined broadcast target area, the system including a broadcast service bureau communicatively coupled for receiving from ~~one of a plurality of coupled~~ broadcast agent access system ~~systems~~ providing a broadcast request from an originating broadcast agent associated one broadcast agent message origination ~~systems~~. ~~The systems;~~ the received broadcast request includes a broadcast agent identification, the geographically defined broadcast target area, and a broadcast message, the broadcast service bureau ~~configured for~~ verifying the broadcast request as a function of the broadcast agent identification including an authority of the originating broadcast agent to send the broadcast message to the broadcast target ~~area~~. ~~The area;~~ the broadcast service bureau processing the verified broadcast request for transmission to one or more broadcast message networks providing broadcast message alerting service to at least a portion of the broadcast target area.

CONCLUSION

It is believed that all items addressed in the Notice of Missing Parts have been properly accommodated. Applicants therefore respectfully request that the Office examine the application as filed.

Other than the Missing Part fee of \$65 for the delayed filed inventor Declarations, Applicants believe that he does not owe any other fee in connection with this filing. If, however, Applicants do owe any such other fee, the Commissioner is hereby authorized to charge the fee to Deposit Account No. 162201. In addition, if there is ever any other fee deficiency or overpayment under 37 C.F.R. §1.16 or 1.17 in connection with this patent application, the Commissioner is hereby authorized to charge such deficiency or overpayment to Deposit Account No. 162201.

Respectfully submitted,

Dated: 2/14/12 _____

s/David L. Howard/ _____

DAVID L. HOWARD
Reg. No. 41,502
POLSTER LIEDER WOODRUFF & LUCCHESI
Suite 200
12412 Powerscourt Drive
St. Louis, MO 63131
Tel: 314-238-2460
Fax: 314-238-2401

**DECLARATION AND POWER OF ATTORNEY
FOR PATENT APPLICATION**

I hereby declare that:

Each inventor's residence, mailing address, and citizenship are as stated below next to their name.

I believe the inventor(s) named below to be the original and first inventor(s) of the subject matter that is claimed and for which a patent is sought on the invention entitled **BROADCAST ALERTING MESSAGE AGGREGATOR/GATEWAY SYSTEM AND METHOD**, the specification of which was filed on December 5, 2011 as United States Application Number 13/311,448 and as attorney docket number ENIT 9834C2.

I hereby state that I have reviewed and understand the contents of the above-identified specification, including the claims, as amended by any amendment specifically referred to above.

I acknowledge the duty to disclose information which is material to patentability as defined in 37 CFR 1.56, including for continuation-in-part applications, material information which became available between the filing date of the prior application and the national or PCT international filing date of the continuation-in-part application.

If checked, the undersigned hereby grants the USPTO authority to provide the European Patent Office (EPO), the Japan Patent Office (JPO), and any other intellectual property offices in which a foreign application claiming priority to the above-identified application is filed access to the above-identified patent application. See 37 CFR 1.14(c) and (h). This box should not be checked if the applicant does not wish the EPO, JPO, or other intellectual property office in which a foreign application claiming priority to the above-identified application is filed to have access to the application.

In accordance with 37 CFR 1.14(h)(3), access will be provided to a copy of the application-as-filed with respect to: 1) the above-identified application, 2) any foreign application to which the above-identified application claims priority under 35 USC 119(a)-(d) if a copy of the foreign application that satisfies the certified copy requirement of 37 CFR 1.55 has been filed in the above-identified US application, and 3) any U.S. application form which benefit is sought in the above-identified application.

In accordance with 37 CFR 1.14(c), access may be provided to information concerning the date of filing the Authorization to Permit Access to Application by Participating Offices.

I hereby claim the benefit under Title 35, United States Code, §119(e) of any United States Provisional Applications listed below:

<u>60/544,739</u>	<u>2/13/04</u>
Application Number	Filing Date

I hereby claim the benefit under Title 35, United States Code, §120 of any United States applications listed below:

<u>12/559,405</u>	<u>9/14/09</u>	<u>Patented (Patent No. 8073903)</u>
(Application No.)	(Filing Date)	(Status - patented, pending, abandoned)

ENIT 9834C2

Page 1 of 2

11/057,704
(Application No.)

2/14/05
(Filing Date)

Patented (Patent No. 7752259)
(Status - patented, pending, abandoned)

I hereby appoint the registered attorneys associated with **Customer Number 001688** to prosecute this application and to transact all business in the Patent and Trademark Office connected therewith.

Address all correspondence to **Customer Number 001688**.

Direct all telephone calls to David Howard at Telephone No. (314) 238-2400.

I hereby declare that all statements made herein of my own knowledge are true and that all statements made on information and belief are believed to be true; and further that these statements were made with the knowledge that willful false statements and the like so made are punishable by fine or imprisonment, or both, under 18 U.S.C. 1001 and that such willful false statements may jeopardize the validity of the application or any patent issued thereon.

Full name of First Inventor: Mark Andrew Wood

Inventor's Signature:  Date: 14/FEB/2011
Residence: City of Haselmere, Surrey
Citizenship: Great Britain
Post Office Address: 8 Lion Lane, Haselmere, Surrey GB GU17 1JF

Full name of Second Inventor: Kevin Russell Preston

Inventor's Signature: _____ Date: _____
Residence: City of Gwent
Citizenship: Great Britain
Post Office Address: Nanty-Celstad Farm, Pennilwyn Lane Machen,
Gwent GB CF83 8RL

Full name of Third Inventor: Douglas Weiser

Inventor's Signature: _____ Date: _____
Residence: City of New Port Richey, State of Florida
Citizenship: US
Post Office Address: 4218 Rudder Way, New Port Richey, FL 34652

**DECLARATION AND POWER OF ATTORNEY
FOR PATENT APPLICATION**

I hereby declare that:

Each inventor's residence, mailing address, and citizenship are as stated below next to their name.

I believe the inventor(s) named below to be the original and first inventor(s) of the subject matter that is claimed and for which a patent is sought on the invention entitled **BROADCAST ALERTING MESSAGE AGGREGATOR/GATEWAY SYSTEM AND METHOD**, the specification of which was filed on December 5, 2011 as United States Application Number 13/311,448 and as attorney docket number ENIT 9834C2.

I hereby state that I have reviewed and understand the contents of the above-identified specification, including the claims, as amended by any amendment specifically referred to above.

I acknowledge the duty to disclose information which is material to patentability as defined in 37 CFR 1.56, including for continuation-in-part applications, material information which became available between the filing date of the prior application and the national or PCT international filing date of the continuation-in-part application.

If checked, the undersigned hereby grants the USPTO authority to provide the European Patent Office (EPO), the Japan Patent Office (JPO), and any other intellectual property offices in which a foreign application claiming priority to the above-identified application is filed access to the above-identified patent application. See 37 CFR 1.14(c) and (h). This box should not be checked if the applicant does not wish the EPO, JPO, or other intellectual property office in which a foreign application claiming priority to the above-identified application is filed to have access to the application.

In accordance with 37 CFR 1.14(h)(3), access will be provided to a copy of the application-as-filed with respect to: 1) the above-identified application, 2) any foreign application to which the above-identified application claims priority under 35 USC 119(a)-(d) if a copy of the foreign application that satisfies the certified copy requirement of 37 CFR 1.55 has been filed in the above-identified US application, and 3) any U.S. application form which benefit is sought in the above-identified application.

In accordance with 37 CFR 1.14(c), access may be provided to information concerning the date of filing the Authorization to Permit Access to Application by Participating Offices.

I hereby claim the benefit under Title 35, United States Code, §119(e) of any United States Provisional Applications listed below:

<u>60/544,739</u>	<u>2/13/04</u>
Application Number	Filing Date

I hereby claim the benefit under Title 35, United States Code, §120 of any United States applications listed below:

<u>12/559,405</u>	<u>9/14/09</u>	<u>Patented (Patent No. 8073903)</u>
(Application No.)	(Filing Date)	(Status - patented, pending, abandoned)

ENIT 9834C2

Page 1 of 2

11/057,704
(Application No.)

2/14/05
(Filing Date)

Patented (Patent No. 7752259)
(Status - patented, pending, abandoned)

I hereby appoint the registered attorneys associated with **Customer Number 001688** to prosecute this application and to transact all business in the Patent and Trademark Office connected therewith.

Address all correspondence to **Customer Number 001688**.

Direct all telephone calls to David Howard at Telephone No. (314) 238-2400.

I hereby declare that all statements made herein of my own knowledge are true and that all statements made on information and belief are believed to be true; and further that these statements were made with the knowledge that willful false statements and the like so made are punishable by fine or imprisonment, or both, under 18 U.S.C. 1001 and that such willful false statements may jeopardize the validity of the application or any patent issued thereon.

Full name of First Inventor: Mark Andrew Wood

Inventor's Signature: _____ Date: _____
Residence: City of Haselmere, Surrey
Citizenship: Great Britain
Post Office Address: 3 Lion Lane, Haselmere, Surrey GB GU17 1JF

Full name of Second Inventor: Kevin Russell Preston

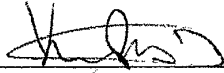
Inventor's Signature:  Date: 17/1/12
Residence: City of Newport
Citizenship: Great Britain
Post Office Address: Stonegate, Glasllwch Lane
Newport, NP20 3PR, UK

Full name of Third Inventor: Douglas Weiser

Inventor's Signature: _____ Date: _____
Residence: City of New Port Richey, State of Florida
Citizenship: US
Post Office Address: 4218 Rudder Way, New Port Richey, FL 34652

**DECLARATION AND POWER OF ATTORNEY
FOR PATENT APPLICATION**

I hereby declare that:

Each inventor's residence, mailing address, and citizenship are as stated below next to their name.

I believe the inventor(s) named below to be the original and first inventor(s) of the subject matter that is claimed and for which a patent is sought on the invention entitled **BROADCAST ALERTING MESSAGE AGGREGATOR/GATEWAY SYSTEM AND METHOD**, the specification of which was filed on December 5, 2011 as United States Application Number 13/311,448 and as attorney docket number ENIT 9834C2.

I hereby state that I have reviewed and understand the contents of the above-identified specification, including the claims, as amended by any amendment specifically referred to above.

I acknowledge the duty to disclose information which is material to patentability as defined in 37 CFR 1.56, including for continuation-in-part applications, material information which became available between the filing date of the prior application and the national or PCT international filing date of the continuation-in-part application.

If checked, the undersigned hereby grants the USPTO authority to provide the European Patent Office (EPO), the Japan Patent Office (JPO), and any other intellectual property offices in which a foreign application claiming priority to the above-identified application is filed access to the above-identified patent application. See 37 CFR 1.14(c) and (h). This box should not be checked if the applicant does not wish the EPO, JPO, or other intellectual property office in which a foreign application claiming priority to the above-identified application is filed to have access to the application.

In accordance with 37 CFR 1.14(h)(3), access will be provided to a copy of the application-as-filed with respect to: 1) the above-identified application, 2) any foreign application to which the above-identified application claims priority under 35 USC 119(a)-(d) if a copy of the foreign application that satisfies the certified copy requirement of 37 CFR 1.55 has been filed in the above-identified US application, and 3) any U.S. application form which benefit is sought in the above-identified application.

In accordance with 37 CFR 1.14(c), access may be provided to information concerning the date of filing the Authorization to Permit Access to Application by Participating Offices.

I hereby claim the benefit under Title 35, United States Code, §119(e) of any United States Provisional Applications listed below:

<u>60/544,739</u>	<u>2/13/04</u>
Application Number	Filing Date

I hereby claim the benefit under Title 35, United States Code, §120 of any United States applications listed below:

<u>12/559,405</u>	<u>9/14/09</u>	<u>Patented (Patent No. 8073903)</u>
(Application No.)	(Filing Date)	(Status - patented, pending, abandoned)

11/057,704
(Application No.)

2/14/05
(Filing Date)

Patented (Patent No. 7752259)
(Status - patented, pending, abandoned)

I hereby appoint the registered attorneys associated with **Customer Number 001688** to prosecute this application and to transact all business in the Patent and Trademark Office connected therewith.

Address all correspondence to **Customer Number 001688**.

Direct all telephone calls to David Howard at Telephone No. (314) 238-2400.

I hereby declare that all statements made herein of my own knowledge are true and that all statements made on information and belief are believed to be true; and further that these statements were made with the knowledge that willful false statements and the like so made are punishable by fine or imprisonment, or both, under 18 U.S.C. 1001 and that such willful false statements may jeopardize the validity of the application or any patent issued thereon.

Full name of First Inventor: Mark Andrew Wood

Inventor's Signature: _____ Date: _____
Residence: City of Haselmere, Surrey
Citizenship: Great Britain
Post Office Address: 3 Lion Lane, Haselmere, Surrey GB GU17 1JF

Full name of Second Inventor: Kevin Russell Preston

Inventor's Signature: _____ Date: _____
Residence: City of Gwent
Citizenship: Great Britain
Post Office Address: Nanty- Celslad Farm, Pennilwyn Lane Machen,
Gwent GB CF83 8RL

Full name of Third Inventor: Douglas Weiser

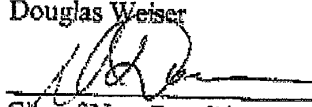
Inventor's Signature:  Date: 1/16/2012
Residence: City of New Port Richey, State of Florida
Citizenship: US
Post Office Address: 4218 Rudder Way, New Port Richey, FL 34652

Electronic Patent Application Fee Transmittal

Application Number:	13311448				
Filing Date:	05-Dec-2011				
Title of Invention:	BROADCAST ALERTING MESSAGE AGGREGATOR/GATEWAY SYSTEM AND METHOD				
First Named Inventor/Applicant Name:	Mark Andrew Wood				
Filer:	David L. Howard/Kim Adler				
Attorney Docket Number:	ENIT 9834C2				
Filed as Small Entity					
Utility under 35 USC 111(a) Filing Fees					
Description	Fee Code	Quantity	Amount	Sub-Total in USD(\$)	
Basic Filing:					
Pages:					
Claims:					
Miscellaneous-Filing:					
Late filing fee for oath or declaration	2051	1	65	65	
Petition:					
Patent-Appeals-and-Interference:					
Post-Allowance-and-Post-Issuance:					
Extension-of-Time:					

Description	Fee Code	Quantity	Amount	Sub-Total in USD(\$)
Miscellaneous:				
Total in USD (\$)				65

Electronic Acknowledgement Receipt

EFS ID:	12074365
Application Number:	13311448
International Application Number:	
Confirmation Number:	9039
Title of Invention:	BROADCAST ALERTING MESSAGE AGGREGATOR/GATEWAY SYSTEM AND METHOD
First Named Inventor/Applicant Name:	Mark Andrew Wood
Customer Number:	1688
Filer:	David L. Howard
Filer Authorized By:	
Attorney Docket Number:	ENIT 9834C2
Receipt Date:	14-FEB-2012
Filing Date:	05-DEC-2011
Time Stamp:	16:24:54
Application Type:	Utility under 35 USC 111(a)

Payment information:

Submitted with Payment	yes
Payment Type	Deposit Account
Payment was successfully received in RAM	\$65
RAM confirmation Number	3415
Deposit Account	162201
Authorized User	

File Listing:

Document Number	Document Description	File Name	File Size(Bytes)/ Message Digest	Multi Part /.zip	Pages (if appl.)
-----------------	----------------------	-----------	-------------------------------------	------------------	------------------

1		ENIT_9834C2_Preliminary_Amendment.pdf	23161 09e8a7f99b8c1a5fb022f1745a12d54164a05ea0	yes	3
Multipart Description/PDF files in .zip description					
		Document Description	Start	End	
		Preliminary Amendment	1	1	
		Abstract	2	2	
		Applicant Arguments/Remarks Made in an Amendment	3	3	
Warnings:					
Information:					
2	Oath or Declaration filed	ENIT_9834C2_Executed_Wood_Declaration.pdf	548673 3246e28fadd70836bb72efa379333664726cc1ae	no	2
Warnings:					
Information:					
3	Oath or Declaration filed	ENIT_9834C2_Executed_Preston_Declaration.pdf	116864 98540f9395f540914a79c3facd68481ca7a59e70	no	2
Warnings:					
Information:					
4	Oath or Declaration filed	ENIT_9834C2_Executed>Weiser_Declaration.pdf	124421 a890f0e1be374e42675d3a5f7fa580aab7b54	no	2
Warnings:					
Information:					
5	Fee Worksheet (SB06)	fee-info.pdf	30385 53a9d69e516b19b65958bc58c68577dc62562425	no	2
Warnings:					
Information:					
Total Files Size (in bytes):			843504		

This Acknowledgement Receipt evidences receipt on the noted date by the USPTO of the indicated documents, characterized by the applicant, and including page counts, where applicable. It serves as evidence of receipt similar to a Post Card, as described in MPEP 503.

New Applications Under 35 U.S.C. 111

If a new application is being filed and the application includes the necessary components for a filing date (see 37 CFR 1.53(b)-(d) and MPEP 506), a Filing Receipt (37 CFR 1.54) will be issued in due course and the date shown on this Acknowledgement Receipt will establish the filing date of the application.

National Stage of an International Application under 35 U.S.C. 371

If a timely submission to enter the national stage of an international application is compliant with the conditions of 35 U.S.C. 371 and other applicable requirements a Form PCT/DO/EO/903 indicating acceptance of the application as a national stage submission under 35 U.S.C. 371 will be issued in addition to the Filing Receipt, in due course.

New International Application Filed with the USPTO as a Receiving Office

If a new international application is being filed and the international application includes the necessary components for an international filing date (see PCT Article 11 and MPEP 1810), a Notification of the International Application Number and of the International Filing Date (Form PCT/RO/105) will be issued in due course, subject to prescriptions concerning national security, and the date shown on this Acknowledgement Receipt will establish the international filing date of the application.

PATENT APPLICATION FEE DETERMINATION RECORD						Application or Docket Number 13/311,448			
Substitute for Form PTO-875									
APPLICATION AS FILED - PART I				SMALL ENTITY		OTHER THAN SMALL ENTITY			
(Column 1)		(Column 2)							
FOR	NUMBER FILED	NUMBER EXTRA	RATE(\$)	FEE(\$)	RATE(\$)	FEE(\$)			
BASIC FEE (37 CFR 1.16(a), (b), or (c))	N/A	N/A	N/A	95	N/A				
SEARCH FEE (37 CFR 1.16(k), (l), or (m))	N/A	N/A	N/A	310	N/A				
EXAMINATION FEE (37 CFR 1.16(o), (p), or (q))	N/A	N/A	N/A	125	N/A				
TOTAL CLAIMS (37 CFR 1.16(i))	20	minus 20 = *	x 30 =	0.00	OR				
INDEPENDENT CLAIMS (37 CFR 1.16(h))	2	minus 3 = *	x 125 =	0.00	OR				
APPLICATION SIZE FEE (37 CFR 1.16(s))	If the specification and drawings exceed 100 sheets of paper, the application size fee due is \$310 (\$155 for small entity) for each additional 50 sheets or fraction thereof. See 35 U.S.C. 41(a)(1)(G) and 37 CFR 1.16(s).			0.00					
MULTIPLE DEPENDENT CLAIM PRESENT (37 CFR 1.16(j))				0.00					
* If the difference in column 1 is less than zero, enter "0" in column 2.				TOTAL	530	TOTAL			
APPLICATION AS AMENDED - PART II									
(Column 1)		(Column 2)		(Column 3)		SMALL ENTITY		OTHER THAN SMALL ENTITY	
AMENDMENT A	CLAIMS REMAINING AFTER AMENDMENT	HIGHEST NUMBER PREVIOUSLY PAID FOR	PRESENT EXTRA	RATE(\$)	ADDITIONAL FEE(\$)	RATE(\$)	ADDITIONAL FEE(\$)		
	Total (37 CFR 1.16(i))	*	Minus **	=	x	=	OR	x	=
	Independent (37 CFR 1.16(h))	*	Minus ***	=	x	=	OR	x	=
	Application Size Fee (37 CFR 1.16(s))						OR		
	FIRST PRESENTATION OF MULTIPLE DEPENDENT CLAIM (37 CFR 1.16(j))						OR		
				TOTAL ADD'L FEE		TOTAL ADD'L FEE			
AMENDMENT B	CLAIMS REMAINING AFTER AMENDMENT	HIGHEST NUMBER PREVIOUSLY PAID FOR	PRESENT EXTRA	RATE(\$)	ADDITIONAL FEE(\$)	RATE(\$)	ADDITIONAL FEE(\$)		
	Total (37 CFR 1.16(i))	*	Minus **	=	x	=	OR	x	=
	Independent (37 CFR 1.16(h))	*	Minus ***	=	x	=	OR	x	=
	Application Size Fee (37 CFR 1.16(s))						OR		
	FIRST PRESENTATION OF MULTIPLE DEPENDENT CLAIM (37 CFR 1.16(j))						OR		
				TOTAL ADD'L FEE		TOTAL ADD'L FEE			
<p>* If the entry in column 1 is less than the entry in column 2, write "0" in column 3.</p> <p>** If the "Highest Number Previously Paid For" IN THIS SPACE is less than 20, enter "20".</p> <p>*** If the "Highest Number Previously Paid For" IN THIS SPACE is less than 3, enter "3".</p> <p>The "Highest Number Previously Paid For" (Total or Independent) is the highest found in the appropriate box in column 1.</p>									



UNITED STATES PATENT AND TRADEMARK OFFICE

UNITED STATES DEPARTMENT OF COMMERCE
United States Patent and Trademark Office
Address: COMMISSIONER FOR PATENTS
P.O. Box 1450
Alexandria, Virginia 22313-1450
www.uspto.gov

Table with 7 columns: APPLICATION NUMBER, FILING or 371(c) DATE, GRP ART UNIT, FIL FEE REC'D, ATTY. DOCKET NO, TOT CLAIMS, IND CLAIMS. Row 1: 13/311,448, 12/05/2011, 2617, 595, ENIT 9834C2, 20, 2

CONFIRMATION NO. 9039

UPDATED FILING RECEIPT

1688
Polster, Lieder, Woodruff & Lucchesi, L.C.
12412 Powerscourt Dr. Suite 200
St. Louis, MO 63131-3615



Date Mailed: 02/24/2012

Receipt is acknowledged of this non-provisional patent application. The application will be taken up for examination in due course. Applicant will be notified as to the results of the examination. Any correspondence concerning the application must include the following identification information: the U.S. APPLICATION NUMBER, FILING DATE, NAME OF APPLICANT, and TITLE OF INVENTION. Fees transmitted by check or draft are subject to collection. Please verify the accuracy of the data presented on this receipt. If an error is noted on this Filing Receipt, please submit a written request for a Filing Receipt Correction. Please provide a copy of this Filing Receipt with the changes noted thereon. If you received a "Notice to File Missing Parts" for this application, please submit any corrections to this Filing Receipt with your reply to the Notice. When the USPTO processes the reply to the Notice, the USPTO will generate another Filing Receipt incorporating the requested corrections

Applicant(s)

Mark Andrew Wood, Haslemere, UNITED KINGDOM;
Kevin Russell Preston, Newport, UNITED KINGDOM;
Douglas Weiser, New Port Richey, FL;

Assignment For Published Patent Application

ENVISIONIT LLC, St. Charles, MO

Power of Attorney: The patent practitioners associated with Customer Number 001688

Domestic Priority data as claimed by applicant

This application is a CON of 12/559,405 09/14/2009 PAT 8073903
which is a CON of 11/057,704 02/14/2005 PAT 7752259
which claims benefit of 60/544,739 02/13/2004

Foreign Applications (You may be eligible to benefit from the Patent Prosecution Highway program at the USPTO. Please see http://www.uspto.gov for more information.)

Permission to Access - A proper Authorization to Permit Access to Application by Participating Offices (PTO/SB/39 or its equivalent) has been received by the USPTO.

If Required, Foreign Filing License Granted: 12/16/2011

The country code and number of your priority application, to be used for filing abroad under the Paris Convention, is US 13/311,448

Projected Publication Date: 06/07/2012

Non-Publication Request: No

Early Publication Request: No

**** SMALL ENTITY ****

Title

BROADCAST ALERTING MESSAGE AGGREGATOR/GATEWAY SYSTEM AND METHOD

Preliminary Class

455

PROTECTING YOUR INVENTION OUTSIDE THE UNITED STATES

Since the rights granted by a U.S. patent extend only throughout the territory of the United States and have no effect in a foreign country, an inventor who wishes patent protection in another country must apply for a patent in a specific country or in regional patent offices. Applicants may wish to consider the filing of an international application under the Patent Cooperation Treaty (PCT). An international (PCT) application generally has the same effect as a regular national patent application in each PCT-member country. The PCT process **simplifies** the filing of patent applications on the same invention in member countries, but **does not result** in a grant of "an international patent" and does not eliminate the need of applicants to file additional documents and fees in countries where patent protection is desired.

Almost every country has its own patent law, and a person desiring a patent in a particular country must make an application for patent in that country in accordance with its particular laws. Since the laws of many countries differ in various respects from the patent law of the United States, applicants are advised to seek guidance from specific foreign countries to ensure that patent rights are not lost prematurely.

Applicants also are advised that in the case of inventions made in the United States, the Director of the USPTO must issue a license before applicants can apply for a patent in a foreign country. The filing of a U.S. patent application serves as a request for a foreign filing license. The application's filing receipt contains further information and guidance as to the status of applicant's license for foreign filing.

Applicants may wish to consult the USPTO booklet, "General Information Concerning Patents" (specifically, the section entitled "Treaties and Foreign Patents") for more information on timeframes and deadlines for filing foreign patent applications. The guide is available either by contacting the USPTO Contact Center at 800-786-9199, or it can be viewed on the USPTO website at <http://www.uspto.gov/web/offices/pac/doc/general/index.html>.

For information on preventing theft of your intellectual property (patents, trademarks and copyrights), you may wish to consult the U.S. Government website, <http://www.stopfakes.gov>. Part of a Department of Commerce initiative, this website includes self-help "toolkits" giving innovators guidance on how to protect intellectual property in specific countries such as China, Korea and Mexico. For questions regarding patent enforcement issues, applicants may call the U.S. Government hotline at 1-866-999-HALT (1-866-999-4158).

LICENSE FOR FOREIGN FILING UNDER

Title 35, United States Code, Section 184

Title 37, Code of Federal Regulations, 5.11 & 5.15

GRANTED

The applicant has been granted a license under 35 U.S.C. 184, if the phrase "IF REQUIRED, FOREIGN FILING LICENSE GRANTED" followed by a date appears on this form. Such licenses are issued in all applications where

page 2 of 3

the conditions for issuance of a license have been met, regardless of whether or not a license may be required as set forth in 37 CFR 5.15. The scope and limitations of this license are set forth in 37 CFR 5.15(a) unless an earlier license has been issued under 37 CFR 5.15(b). The license is subject to revocation upon written notification. The date indicated is the effective date of the license, unless an earlier license of similar scope has been granted under 37 CFR 5.13 or 5.14.

This license is to be retained by the licensee and may be used at any time on or after the effective date thereof unless it is revoked. This license is automatically transferred to any related applications(s) filed under 37 CFR 1.53(d). This license is not retroactive.

The grant of a license does not in any way lessen the responsibility of a licensee for the security of the subject matter as imposed by any Government contract or the provisions of existing laws relating to espionage and the national security or the export of technical data. Licensees should apprise themselves of current regulations especially with respect to certain countries, of other agencies, particularly the Office of Defense Trade Controls, Department of State (with respect to Arms, Munitions and Implements of War (22 CFR 121-128)); the Bureau of Industry and Security, Department of Commerce (15 CFR parts 730-774); the Office of Foreign Assets Control, Department of Treasury (31 CFR Parts 500+) and the Department of Energy.

NOT GRANTED

No license under 35 U.S.C. 184 has been granted at this time, if the phrase "IF REQUIRED, FOREIGN FILING LICENSE GRANTED" DOES NOT appear on this form. Applicant may still petition for a license under 37 CFR 5.12, if a license is desired before the expiration of 6 months from the filing date of the application. If 6 months has lapsed from the filing date of this application and the licensee has not received any indication of a secrecy order under 35 U.S.C. 181, the licensee may foreign file the application pursuant to 37 CFR 5.15(b).

SelectUSA

The United States represents the largest, most dynamic marketplace in the world and is an unparalleled location for business investment, innovation and commercialization of new technologies. The USA offers tremendous resources and advantages for those who invest and manufacture goods here. Through SelectUSA, our nation works to encourage, facilitate, and accelerate business investment. To learn more about why the USA is the best country in the world to develop technology, manufacture products, and grow your business, visit SelectUSA.gov.



UNITED STATES PATENT AND TRADEMARK OFFICE

UNITED STATES DEPARTMENT OF COMMERCE
United States Patent and Trademark Office
Address: COMMISSIONER FOR PATENTS
P.O. Box 1450
Alexandria, Virginia 22313-1450
www.uspto.gov

Table with 5 columns: APPLICATION NO., FILING DATE, FIRST NAMED INVENTOR, ATTORNEY DOCKET NO., CONFIRMATION NO.
13/311,448 12/05/2011 Mark Andrew Wood ENIT 9834C2 9039

1688 7590 04/24/2012
Polster, Lieder, Woodruff & Lucchesi, L.C.
12412 Powerscourt Dr. Suite 200
St. Louis, MO 63131-3615

Table with 1 column: EXAMINER

JOO, JOSHUA

Table with 2 columns: ART UNIT, PAPER NUMBER

2445

Table with 2 columns: MAIL DATE, DELIVERY MODE

04/24/2012

PAPER

Please find below and/or attached an Office communication concerning this application or proceeding.

The time period for reply, if any, is set in the attached communication.

Office Action Summary	Application No. 13/311,448	Applicant(s) WOOD ET AL.	
	Examiner JOSHUA JOO	Art Unit 2445	

-- The MAILING DATE of this communication appears on the cover sheet with the correspondence address --
Period for Reply

A SHORTENED STATUTORY PERIOD FOR REPLY IS SET TO EXPIRE 3 MONTH(S) OR THIRTY (30) DAYS, WHICHEVER IS LONGER, FROM THE MAILING DATE OF THIS COMMUNICATION.

- Extensions of time may be available under the provisions of 37 CFR 1.136(a). In no event, however, may a reply be timely filed after SIX (6) MONTHS from the mailing date of this communication.
- If NO period for reply is specified above, the maximum statutory period will apply and will expire SIX (6) MONTHS from the mailing date of this communication.
- Failure to reply within the set or extended period for reply will, by statute, cause the application to become ABANDONED (35 U.S.C. § 133). Any reply received by the Office later than three months after the mailing date of this communication, even if timely filed, may reduce any earned patent term adjustment. See 37 CFR 1.704(b).

Status

- 1) Responsive to communication(s) filed on 05 December 2011.
- 2a) This action is **FINAL**.
- 2b) This action is non-final.
- 3) An election was made by the applicant in response to a restriction requirement set forth during the interview on _____; the restriction requirement and election have been incorporated into this action.
- 4) Since this application is in condition for allowance except for formal matters, prosecution as to the merits is closed in accordance with the practice under *Ex parte Quayle*, 1935 C.D. 11, 453 O.G. 213.

Disposition of Claims

- 5) Claim(s) 1-20 is/are pending in the application.
 - 5a) Of the above claim(s) _____ is/are withdrawn from consideration.
- 6) Claim(s) _____ is/are allowed.
- 7) Claim(s) 1-20 is/are rejected.
- 8) Claim(s) _____ is/are objected to.
- 9) Claim(s) _____ are subject to restriction and/or election requirement.

Application Papers

- 10) The specification is objected to by the Examiner.
- 11) The drawing(s) filed on 05 December 2011 is/are: a) accepted or b) objected to by the Examiner.
 - Applicant may not request that any objection to the drawing(s) be held in abeyance. See 37 CFR 1.85(a).
 - Replacement drawing sheet(s) including the correction is required if the drawing(s) is objected to. See 37 CFR 1.121(d).
- 12) The oath or declaration is objected to by the Examiner. Note the attached Office Action or form PTO-152.

Priority under 35 U.S.C. § 119

- 13) Acknowledgment is made of a claim for foreign priority under 35 U.S.C. § 119(a)-(d) or (f).
 - a) All b) Some * c) None of:
 - 1. Certified copies of the priority documents have been received.
 - 2. Certified copies of the priority documents have been received in Application No. _____.
 - 3. Copies of the certified copies of the priority documents have been received in this National Stage application from the International Bureau (PCT Rule 17.2(a)).
- * See the attached detailed Office action for a list of the certified copies not received.

Attachment(s)

- 1) Notice of References Cited (PTO-892)
- 2) Notice of Draftsperson's Patent Drawing Review (PTO-948)
- 3) Information Disclosure Statement(s) (PTO/SB/08)
Paper No(s)/Mail Date 12/5/11.
- 4) Interview Summary (PTO-413)
Paper No(s)/Mail Date. _____.
- 5) Notice of Informal Patent Application
- 6) Other: _____.

Detailed Action

Claims 1-20 are pending in the application.

Information Disclosure Statement

The information disclosure statements (IDS) submitted on December 5, 2011 are in compliance with the provisions of 37 CFR 1.97. Accordingly, the IDS are considered by the Examiner.

Double Patenting

The nonstatutory double patenting rejection is based on a judicially created doctrine grounded in public policy (a policy reflected in the statute) so as to prevent the unjustified or improper timewise extension of the "right to exclude" granted by a patent and to prevent possible harassment by multiple assignees. A nonstatutory obviousness-type double patenting rejection is appropriate where the conflicting claims are not identical, but at least one examined application claim is not patentably distinct from the reference claim(s) because the examined application claim is either anticipated by, or would have been obvious over, the reference claim(s). See, e.g., *In re Berg*, 140 F.3d 1428, 46 USPQ2d 1226 (Fed. Cir. 1998); *In re Goodman*, 11 F.3d 1046, 29 USPQ2d 2010 (Fed. Cir. 1993); *In re Longi*, 759 F.2d 887, 225 USPQ 645 (Fed. Cir. 1985); *In re Van Ornum*, 686 F.2d 937, 214 USPQ 761 (CCPA 1982); *In re Vogel*, 422 F.2d 438, 164 USPQ 619 (CCPA 1970); and *In re Thorington*, 418 F.2d 528, 163 USPQ 644 (CCPA 1969).

A timely filed terminal disclaimer in compliance with 37 CFR 1.321(c) or 1.321(d) may be used to overcome an actual or provisional rejection based on a nonstatutory double patenting ground provided the conflicting application or patent either is shown to be commonly owned with this application, or claims an invention made as a result of activities undertaken within the scope of a joint research agreement.

Effective January 1, 1994, a registered attorney or agent of record may sign a terminal disclaimer. A terminal disclaimer signed by the assignee must fully comply with 37 CFR 3.73(b).

Claims 1-13, 17-20 are rejected on the ground of nonstatutory obviousness-type double patenting as being unpatentable over claims 1-3, 5, 7, and 9 of U.S. Patent No. 8,073,903 (Patent '903 hereinafter).

Although the conflicting claims are not identical, they are not patentably distinct from each other because as shown below, claim 1 of Patent '903 anticipates claim 1 of the instant application and claims 12-13, 17-20 are unpatentable as the claims are anticipated or obvious over claims of Patent '903.

Instant Application	Patent '903
1. A message alert broadcast broker system for providing a broadcast message to a plurality of user devices located within a geographically defined broadcast target area, the system comprising:	1. A message alert broadcast broker system for providing a broadcast message to a plurality of user devices located within a geographically defined broadcast target area, the system comprising:
a broadcast service bureau communicatively coupled for receiving from one of a plurality of coupled broadcast agent access systems providing a broadcast request from an originating broadcast agent associated one broadcast agent message origination systems, the broadcast request including a broadcast agent identification, the geographically defined broadcast target area, and a broadcast message, the broadcast service bureau configured for verifying the broadcast request as a function of the broadcast agent identification including an authority of the originating broadcast agent to send the broadcast message to the broadcast target area,	a broadcast service bureau communicatively coupled for receiving from one of a plurality of coupled broadcast agent access systems providing a broadcast request from an originating broadcast agent associated one broadcast agent access system, the broadcast request including a broadcast agent identification, the geographically defined broadcast target area, a broadcast message, and a broadcast channel code, the broadcast service bureau configured for verifying the broadcast request as a function of the broadcast agent identification including an authority of the originating broadcast agent to send the broadcast message to the broadcast target area using the broadcast channel code,
the broadcast service bureau processing the verified broadcast request for transmission to one or more broadcast message networks providing broadcast message alerting service to at least a portion of the broadcast target area.	the broadcast service bureau processing the verified broadcast request for transmission to one or more mobile telephone networks providing service to at least a portion of the broadcast target area of the broadcast request.

Regarding claims 2, 4, 6, 8-10, 12, 17-18, and 20, the claims are rejected by claims 1-3, 5, 7, and 9 of Patent '903.

Regarding claims 3, 5, 7, and 11, claim 1 of Patent '903 discloses that the broadcast message networks includes a mobile wireless carrier network. Patent '903 does not disclose the other types of networks, wireless Wi-Fi network, digital private radio systems operator network, private radio system network, internet service provider networks, wireline telecommunication network, satellite network, CATV network, radio system, and television system, recited in claims 3, 5, 7, and 11. However, the

networks are well known in the art and it would have been obvious to one of ordinary skill in the art to enable selection from the networks to reach a greater a number of devices.

Regarding claim 13, claim 9 of Patent '903 discloses that the broadcast request includes one or more channel codes that identifies a language, i.e. language identifier, but does not recite selecting from message recall, network selector, and request for message progress status. However, it would have been obvious to one of ordinary skill in the art to select from message recall, network selector, and request for message progress status to provide different purposes for the broadcast message.

Regarding claim 19, the claim is a method that corresponds to the system of claim 1. Therefore, the claim is not rejected under a similar rational.

Claim 14 is rejected on the ground of nonstatutory obviousness-type double patenting as being unpatentable over claim 1 of Patent '903, in view of Atkin et al. US Publication No. 2004/0192258 (Atkin hereinafter).

As per claim 14, Patent '903 does not disclose the system of claim 1 wherein the broadcast message of the broadcast request is a first broadcast message, the first broadcast message being in a first language, and wherein the broadcast request includes a second broadcast message in a second language, and wherein the broadcast service bureau is configured to transmit the broadcast request including at least one of the first broadcast message in the first language and the second broadcast message in the second language.

Atkin discloses a broadcast message a the broadcast request that is a first broadcast message, the first broadcast message being in a first language, and wherein the broadcast request includes a second broadcast message in a second language, and wherein a broadcast service bureau is configured to transmit

Art Unit: 2445

the broadcast request including at least one of the first broadcast message in the first language and the second broadcast message in the second language (Paragraph 0032). It would have been obvious to one of ordinary skill in the art at the time the invention was made to include Aktin's teachings, which would have improved broadcasting by being able to communicate notifications to a greater audience

Claims 15-16 are rejected on the ground of nonstatutory obviousness-type double patenting as being unpatentable over claim 1 of Patent '903, in view of Vella et al. US Publication No. 2004/0103158.

Regarding claim 15-16, claims of patent '903 do not disclose that the broadcast message is a multimedia message and includes at least one of a photograph and a map. Vella discloses a broadcast message that is a multimedia message and includes at least one of a photograph and a map (Paragraphs 0052, 0063). it would have been obvious to one of ordinary skill in the art to include a photograph to enable different ways to present information to users.

Claims 1 and 19 are rejected on the ground of nonstatutory obviousness-type double patenting as being unpatentable over claims 1 and 10 of U.S. Patent No. 7,752,259 (Patent '903 hereinafter).

Instant Application	Patent '259
1. A message alert broadcast broker system for providing a broadcast message to a plurality of user devices located within a geographically defined broadcast target area, the system comprising:	1. A public service message broadcast system providing a broadcast message to a broadcast target area, the system comprising:
a broadcast service bureau communicatively coupled for receiving from one of a plurality of coupled broadcast agent access systems providing a broadcast request from an originating broadcast agent associated one broadcast agent message origination systems, the broadcast request including a broadcast agent identification, the geographically defined broadcast target area, and a broadcast message, the broadcast service bureau configured for verifying the broadcast request as a function of	a broadcast service bureau communicatively coupled to said carrier broadcast center and said broadcast agent access device, said broadcast service bureau configured for receiving the broadcast agent input including the geographically defined broadcast target area and the broadcast message from the broadcast agent access device and transmitting the broadcast message and the broadcast target area to the carrier broadcast server center,

the broadcast agent identification including an authority of the originating broadcast agent to send the broadcast message to the broadcast target area,	wherein the broadcast service bureau verifies an authority of the broadcast agent to transmit the broadcast message to the broadcast target area as a function of a broadcast message jurisdiction of the broadcast agent including the defined broadcast target area.
the broadcast service bureau processing the verified broadcast request for transmission to one or more broadcast message networks providing broadcast message alerting service to at least a portion of the broadcast target area.	10. The system of claim 1 wherein the carrier broadcast service bureau further includes a distributor receiving the broadcast message and broadcast target area and maps the broadcast target area to determine which one or more broadcast distribution networks from among a plurality of broadcast distribution networks provide broadcast distribution systems serving the broadcast target area, and wherein the distributor identifies the broadcast distribution networks for the broadcast target area and determines whether the broadcast distribution network has its own carrier broadcast center.

Regarding claim 19, the claim is a method that corresponds to the system of claim 1. Therefore, the claim is not rejected under a similar rational.

Claim Rejections - 35 USC § 103

The following is a quotation of 35 U.S.C. 103(a) which forms the basis for all obviousness rejections set forth in this Office action:

(a) A patent may not be obtained though the invention is not identically disclosed or described as set forth in section 102 of this title, if the differences between the subject matter sought to be patented and the prior art are such that the subject matter as a whole would have been obvious at the time the invention was made to a person having ordinary skill in the art to which said subject matter pertains. Patentability shall not be negated by the manner in which the invention was made.

Claims 1-8, 12, 15-17, and 19 are rejected under 35 U.S.C. 103(a) as being unpatentable over Vella et al. US Publication No. 2004/0103158 (Vella hereinafter), in view of Allport, US Patent No. 6,480,578 (Allport hereinafter).

As per claim 1, Vella teaches substantially the invention as claimed including a message alert broadcast broker system for providing a broadcast message to a plurality of user devices located within a geographically defined broadcast target area, the system comprising:

a broadcast service bureau communicatively coupled for receiving from one of a plurality of coupled broadcast agent access systems providing a broadcast request from an originating broadcast agent associated one broadcast agent message origination systems, the broadcast request including a broadcast agent identification, the geographically defined broadcast target area, and a broadcast message (Paragraphs 0049, 0051. Receive location and inputted text for alert message. Paragraphs 0055-0056. Select location and provide identification.).

the broadcast service bureau configured for verifying as a function of the broadcast agent identification including an authority of the originating broadcast agent (Paragraph 0056. Verify alert originator's authority.),

the broadcast service bureau processing the verified broadcast request for transmission to one or more broadcast message networks providing broadcast message alerting service to at least a portion of the broadcast target area (Paragraph 0079. Sends formatted messages to public network.).

Vella does not specifically teach the broadcast service bureau configured for verifying the broadcast request as a function of the broadcast agent identification including an authority of the originating broadcast agent to send the broadcast message to the broadcast target area.

Allport discloses a system for broadcasting messaging comprising a broadcast service bureau configured for verifying a broadcast request as a function of a broadcast agent identification including an authority of the originating broadcast agent to send the broadcast message to the broadcast target area (col. 13, lines 10-22; col. 14, lines 45-49).

It would have been obvious to one of ordinary skill in the art at the time the invention was made to combine the teachings for the broadcast service bureau of Vella to be configured for verifying a

broadcast request as a function of a broadcast agent identification including an authority of the originating broadcast agent to send the broadcast message to the broadcast target area as disclosed by Allport. One of ordinary skill in the art would have been motivated to combine the teachings as Vella discloses that changes made be made without departing from scope. Allport, which similarly deals with broadcasting messaging, would have improved security by allowing authorized parties to send certain notifications and provided the benefit of a timely and cost effective means to notify people within geographic regions (col. 2, lines 56-61). Furthermore, it would have been obvious to combine the teachings as all the claimed elements were known in the prior art and one skilled in the art could have combined the elements as claimed by known methods with no change in their respective functions, and the combination would have yielded nothing more than predictable results to one of ordinary skill in the art.

As per claim 19, Vella teaches substantially the invention as claimed including a method of public service broadcast messaging to a broadcast target area, the method comprising:

receiving over an input interface a broadcast request including a broadcast agent identification, a geographically defined broadcast target area, and a broadcast message from one of a plurality of coupled broadcast agent message origination systems (Paragraphs 0049, 0051. Select location and input text for alert message. Paragraphs 0055-0056. Select location and provide identification.);

verifying an authority of the broadcast agent identification including an authority of the originating broadcast agent (Paragraph 0056. Verify alert originator's authority.); and

transmitting the broadcast message over an output interface to one or more coupled broadcast message networks providing broadcast message alerting service to at least a portion of the broadcast target area (Paragraph 0079. Sends formatted messages to public network.).

Vella discloses verifying an authority of the broadcast agent identification including an authority of the originating broadcast agent but not specifically to send the broadcast message to the broadcast target area.

Allport discloses an invention for broadcasting messaging comprising verifying an authority of a broadcast agent identification including an authority of an originating broadcast agent to send a broadcast message to the broadcast target area (col. 13, lines 10-22; col. 14, lines 45-49).

It would have been obvious to one of ordinary skill in the art at the time the invention was made to combine the teachings to verify an authority of the broadcast agent identification including an authority of an originating broadcast agent to send a broadcast message to the broadcast target area as disclosed by Allport. One of ordinary skill in the art would have been motivated to combine the teachings as Vella discloses that changes made be made without departing from scope. Allport, which similarly deals with broadcasting messaging, would have improved security by allowing authorized parties to send certain notifications and provided the benefit of a timely and cost effective means to notify people within geographic regions (col. 2, lines 56-61). Furthermore, it would have been obvious to combine the teachings as all the claimed elements were known in the prior art and one skilled in the art could have combined the elements as claimed by known methods with no change in their respective functions, and the combination would have yielded nothing more than predictable results to one of ordinary skill in the art.

As per claim 2, Vella in view of Allport teach the system of claim 1 wherein the broadcast service bureau is configured for receiving the broadcast request, and identifying the one or more broadcast message networks providing message alerting service to at least a portion of the broadcast target area (Paragraph 0079. Send message to public network. Paragraph 0080. Send message to SMS server 355/357 of cellular carriers.).

As per claim 3, Vella in view of Allport teach the system of claim 2 wherein the one or more message broadcast message networks includes at least one selected from the group consisting of wireless mobile carrier network, wireless Wi-Fi network, digital private radio systems operator network, private radio system network, internet service provider networks, wireline telecommunication network, satellite network, CATV network, radio system, and television system (Paragraph 0079. Send message to public network, Internet. Paragraph 0080. Send message to SMS server 355/357 of cellular carriers.).

As per claim 4, Vella in view of Allport teaches the system of claim 1 wherein the broadcast service bureau further includes a distributor receiving the broadcast message and broadcast target area and mapping the broadcast target area to determine which one or more of the broadcast message networks from among a plurality of broadcast message networks has a broadcast message distribution system serving at least a portion of the broadcast target area, and wherein the distributor identifies the one or more broadcast message networks (Paragraphs 0053, 0066. Determine relevant cellular carriers servicing recipients in the location.).

As per claim 5, Vella in view of Allport teach the system of claim 4 wherein the one or more message broadcast message networks includes at least one selected from the group consisting of wireless mobile carrier network, wireless Wi-Fi network, digital private radio systems operator network, private radio system network, internet service provider networks, wireline telecommunication network, satellite network, CATV network, radio system, and television system (Paragraph 0079. Send message to public network, Internet. Paragraph 0080. Send message to SMS server 355/357 of cellular carriers.).

As per claim 6, Vella in view of Allport teach the system of claim 1 wherein the broadcast service bureau includes an output interface for coupling to one of the one or more broadcast message networks providing message alerting service to at least a portion of the broadcast target area (Fig. 3; Paragraph 0079. Send message to public network, Internet. Paragraph 0080. Send message to SMS server 355/357 of cellular carriers.).

As per claim 7, Vella in view of Allport teach the system of claim 6 wherein the output interface is configured to interface with a message broadcast message network selected from the group consisting of wireless mobile carrier network, wireless Wi-Fi network, digital private radio systems operator network, private radio system network, internet service provider networks, wireline telecommunication network, satellite network, CATV network, radio system, and television system (Paragraph 0079. Send message to public network, Internet. Paragraph 0080. Send message to SMS server 355/357 of cellular carriers.).

As per claim 8, Vella does not specifically teach the system of claim 1 wherein the broadcast service bureau verifies an authority of the broadcast agent to transmit the broadcast message to the broadcast target area as a function of a broadcast message jurisdiction stored in the broadcast service bureau for the originating broadcast agent, the verifying ensuring that the broadcast message jurisdiction of the originating broadcast agent includes the broadcast target area.

Allport discloses a system for broadcasting messaging comprising a broadcast service bureau that verifies an authority of the broadcast agent to transmit a broadcast message to a broadcast target area as a function of a broadcast message jurisdiction stored in the broadcast service bureau for the originating broadcast agent, the verifying ensuring that the broadcast message jurisdiction of the originating broadcast agent includes the broadcast target area (col. 13, lines 10-22; col. 14, lines 45-49).

It would have been obvious to one of ordinary skill in the art at the time the invention was made to combine the above teachings of Allport to the system of Vella. One of ordinary skill in the art would have been motivated to combine the teachings as Vella discloses that changes made be made without departing from scope. Allport, which similarly deals with broadcasting messaging, would have improved security by allowing authorized parties to send certain notifications and provided the benefit of a timely and cost effective means to notify people with geographic regions (col. 2, lines 56-61).

As per claim 12, Vella does not specifically teach the system of claim 1 wherein the broadcast request includes a message type identifying the type of message of the broadcast message request.

Allport discloses a system for broadcasting messaging wherein a broadcast request includes a message type identifying the type of message of the broadcast message request (col. 12, lines 40-51, 66- col. 13, line 10).

It would have been obvious to one of ordinary skill in the art at the time the invention was made to combine the teachings for the broadcast request includes a message type identifying the type of message of the broadcast message request as disclosed by Allport. One of ordinary skill in the art would have been motivated to combine the teachings as Vella discloses that changes made be made without departing from scope. Allport similarly deals with broadcasting messaging and would have improved security by providing timely and cost effective means to notify people of situations (col. 2, lines 56-61).

As per claim 15, Vella in view of Allport teach the system of claim 1 wherein the broadcast message is a multimedia message (Paragraphs 0052, 0063. Include image data.).

As per claim 16, Vella in view of Allport teach the system of claim 15 wherein the multimedia message includes at least one of a photograph and a map (Paragraphs 0052, 0063. Include image data.).

As per claim 17, Vella does not specifically teach the system of claim 1 wherein the broadcast request includes a message type.

Allport discloses a system for broadcasting messaging wherein a broadcast request includes a message type identifying the type of message of the broadcast message request (col. 12, lines 40-51, 66- col. 13, line 10).

It would have been obvious to one of ordinary skill in the art at the time the invention was made to combine the teachings for the broadcast request includes a message type identifying the type of message of the broadcast message request as disclosed by Allport. One of ordinary skill in the art would have been motivated to combine the teachings as Vella discloses that changes made be made without departing from scope. Allport similarly deals with broadcasting messaging and would have improved security by providing timely and cost effective means to notify people of situations (col. 2, lines 56-61).

Claims 9-11 are rejected under 35 U.S.C. 103(a) as being unpatentable over Vella, in view of Allport and Kolsrud, US Publication No. 2004/0203562 (Kolsrud hereinafter).

As per claim 9, Vella in view of Allport teach the system of claim 6 wherein the output interface is configured for interfacing with a carrier broadcast center of a wireless mobile carrier network (Vella: Fig. 3). Vella does not specifically teach the carrier broadcast center converting the broadcast target area to network addresses of wireless transmission devices serving the broadcast target area including determining particular wireless network transmission devices serving at least a portion of the broadcast target area, and identifying the network addresses for each determined particular wireless transmission device and transmitting the broadcast message to the network addresses of the particular wireless transmission devices for wireless transmission by the particular wireless transmission devices to user receiving devices.

Kolsrud discloses a system for broadcasting message comprising a carrier broadcast center converting a broadcast target area to network addresses of wireless transmission devices serving the broadcast target area including determining particular wireless network transmission devices serving at least a portion of the broadcast target area, and identifying the network addresses for each determined particular wireless transmission device and transmitting the broadcast message to the network addresses of the particular wireless transmission devices for wireless transmission by the particular wireless transmission devices to user receiving devices (Paragraphs 0017, 0020).

It would have been obvious to one of ordinary skill in the art at the time the invention was made to combine the above teachings of Kolsrud to the system of Vella. One of ordinary skill in the art would have been motivated to combine the teachings as Vella discloses that changes made be made without departing from scope. Kolsrud similarly deals with broadcasting messaging and would have similarly provided the benefit of efficiently distributing emergency messages to a mass number of people (Paragraph 0007). Furthermore, it would have been obvious to combine the teachings as all the claimed elements were known in the prior art and one skilled in the art could have combined the elements as claimed by known methods with no change in their respective functions, and the combination would have yielded nothing more than predictable results to one of ordinary skill in the art.

As per claim 10, Vella does not specifically teach the system of claim 9 wherein the wireless transmission devices serving the broadcast target area and the particular wireless transmission devices are wireless cellular network transmitters and each of the wireless cellular network transmitters has a cell id network address and the identified network addresses are cell id network addresses.

Kolsrud discloses a system for broadcasting message wherein wireless transmission devices serving a broadcast target area and particular wireless transmission devices are wireless cellular network

transmitters and each of the wireless cellular network transmitters has a cell id network address and the identified network addresses are cell id network addresses (Paragraphs 0017, 0020).

It would have been obvious to one of ordinary skill in the art at the time the invention was made to combine the above teachings of Kolsrud to the system of Vella. One of ordinary skill in the art would have been motivated to combine the teachings as Vella discloses that changes made be made without departing from scope. Kolsrud similarly deals with broadcasting messaging and would have similarly provided the benefit of efficiently distributing emergency messages to a mass number of people (Paragraph 0007). Furthermore, it would have been obvious to combine the teachings as all the claimed elements were known in the prior art and one skilled in the art could have combined the elements as claimed by known methods with no change in their respective functions, and the combination would have yielded nothing more than predictable results to one of ordinary skill in the art.

As per claim 11, Vella in view of Allport and Kolsrud teach the system of claim 9 wherein the wireless transmission devices serving the broadcast target area and the particular wireless transmission devices are Wi-Fi network transmitters, each of the Wi-Fi network transmitters having a Wi-Fi id network address, wherein the identified network addresses are Wi-Fi id network addresses (Paragraph 0079. Send message to public network, Internet. Paragraph 0080. Send message to SMS server 355/357 of cellular carriers.).

Claims 13-14 are rejected under 35 U.S.C. 103(a) as being unpatentable over Vella, in view of Allport and Atkin.

As per claim 13, Vella does not specifically teach the system of claim 1 wherein the broadcast request includes a broadcast message that is an alerting system administrative message selected from the

Art Unit: 2445

group consisting of: message recall, language identifier, network selector, and request for message progress status.

Atkin discloses a system for broadcasting messages, wherein a broadcast message is an alerting system administrative message selected from the group consisting of: message recall, language identifier, network selector, and request for message progress status (Paragraphs 0031, 0035, 0037).

It would have been obvious to one of ordinary skill in the art at the time the invention was made to combine the teachings to include in the request of Vella a broadcast message that is an alerting system administrative message selected from the group consisting of: message recall, language identifier, network selector, and request for message progress status as disclosed by Atkin. One of ordinary skill in the art would have been motivated to combine the teachings as Atkin similarly discloses a system for broadcast messaging and would have improved broadcasting notification in Atkin by providing messages that would enable recipients to understand emergency warning messages (Paragraphs 0002). Furthermore, it would have been obvious to combine the teachings as all the claimed elements were known in the prior art and one skilled in the art could have combined the elements as claimed by known methods with no change in their respective functions, and the combination would have yielded nothing more than predictable results to one of ordinary skill in the art.

As per claim 14, Vella does not specifically teach the system of claim 1 wherein the broadcast message of the broadcast request is a first broadcast message, the first broadcast message being in a first language, and wherein the broadcast request includes a second broadcast message in a second language, and wherein the broadcast service bureau is configured to transmit the broadcast request including at least one of the first broadcast message in the first language and the second broadcast message in the second language.

Atkin discloses a system for broadcasting messages, wherein a broadcast message of a broadcast request is a first broadcast message, the first broadcast message being in a first language, and wherein the broadcast request includes a second broadcast message in a second language, and wherein the broadcast service bureau is configured to transmit the broadcast request including at least one of the first broadcast message in the first language and the second broadcast message in the second language (Paragraphs 0032, 0038).

It would have been obvious to one of ordinary skill in the art at the time the invention was made to combine the teachings to include the above teachings of Atkin to the system of Vella. One of ordinary skill in the art would have been motivated to combine the teachings as Atkin similarly discloses a system for broadcast messaging and would have improved broadcasting notification in Atkin by providing messages that would enable recipients to understand emergency warning messages (Paragraphs 0002).

Claims 18 and 20 are rejected under 35 U.S.C. 103(a) as being unpatentable over Vella, in view of Allport and Zimmers et al. US Publication No. 2005/0013417 (Zimmers hereinafter).

As per claim 18, Vella teaches the system of claim 17 wherein the broadcast service bureau is coupled to a plurality of broadcast message networks, and is configured to select the one or more broadcast message networks from among the plurality of coupled broadcast message networks responsive to at least of the broadcast target area (Paragraphs 0053, 0066. Determine relevant cellular carriers servicing recipients in the location.) but not specifically responsive to at least of the message type.

Zimmers discloses of selecting one or more broadcast message networks from among the plurality of coupled broadcast message networks responsive to at least of a message type and target area (Paragraphs 0087, 0090-0091).

It would have been obvious to one of ordinary skill in the art at the time the invention was made to combine the teachings to select one or more broadcast message networks from among the plurality of

coupled broadcast message networks responsive to at least of a message type and target area as disclosed by Zimmers. One of ordinary skill in the art would have been motivated to combine the teachings as Zimmers similarly discloses a system for broadcast messaging and would have improved broadcasting notification in Atkin by similarly “intelligently” providing notifications and repeat notifications based on different factors such as responses by recipients or expiring of an emergency (Paragraph 0020). Furthermore, it would have been obvious to combine the teachings as all the claimed elements were known in the prior art and one skilled in the art could have combined the elements as claimed by known methods with no change in their respective functions, and the combination would have yielded nothing more than predictable results to one of ordinary skill in the art.

As per claim 20, Vella teaches the method of claim 19 wherein the broadcast request includes a message type, further comprising: selecting the one or more broadcast message networks from among the plurality of coupled broadcast message networks responsive to at least of the message type and the broadcast target area (Paragraphs 0053, 0066. Determine relevant cellular carriers servicing recipients in the location.). Vella does not specifically teach that the request includes a message type and selecting responsive to at least of the message type

Zimmers discloses of selecting one or more broadcast message networks from among the plurality of coupled broadcast message networks responsive to at least of a message type and target area (Paragraphs 0087, 0090-0091).

It would have been obvious to one of ordinary skill in the art at the time the invention was made to combine the teachings to select one or more broadcast message networks from among the plurality of coupled broadcast message networks responsive to at least of a message type and target area as disclosed by Zimmers. One of ordinary skill in the art would have been motivated to combine the teachings as Zimmers similarly discloses a system for broadcast messaging and would have improved broadcasting

notification in Atkin by similarly “intelligently” providing notifications and repeat notifications based on different factors such as responses by recipients or expiring of an emergency (Paragraph 0020).

Conclusion

Examiner has cited particular sections of the reference(s) that are applied to the claims. While the sections are cited for convenience and are representative of the teachings of the prior art, other sections of the reference(s) may be relevant and applicable to the claims. It is respectfully requested that Applicant fully consider the reference(s) in its entirety when responding to the Office action.

A shortened statutory period for reply to this Office action is set to expire **THREE MONTHS** from the mailing date of this action.

Any inquiry concerning this communication or earlier communications from the examiner should be directed to Joshua Joo whose telephone number is 571 272-3966. The examiner can normally be reached on Monday to Friday 7:30AM to 4:00PM EST.

If attempts to reach the examiner by telephone are unsuccessful, the examiner’s supervisor, Lynn Feild can be reached on 571 272-2092. The fax phone number for the organization where this application or proceeding is assigned is 571-273-8300.

Information regarding the status of an application may be obtained from the Patent Application Information Retrieval (PAIR) system. Status information for published applications may be obtained from either Private PAIR or Public PAIR. Status information for unpublished applications is available through Private PAIR only. For more information about the PAIR system, see <http://pair-direct.uspto.gov>. Should you have questions on access to the Private PAIR system, contact the Electronic Business Center (EBC) at 866-217-9197 (toll-free).

Application/Control Number: 13/311,448
Art Unit: 2445

Page 20

/Joshua Joo/
Primary Examiner, Art Unit 2445

Notice of References Cited	Application/Control No. 13/311,448	Applicant(s)/Patent Under Reexamination WOOD ET AL.	
	Examiner JOSHUA JOO	Art Unit 2445	Page 1 of 1

U.S. PATENT DOCUMENTS

*	Document Number Country Code-Number-Kind Code	Date MM-YYYY	Name	Classification
*	A US-6,480,578	11-2002	Allport, Douglas C.	379/48
*	B US-2004/0103158	05-2004	Vella et al.	709/206
*	C US-2004/0192258	09-2004	Atkin et al.	455/412.1
*	D US-2005/0013417	01-2005	Zimmers et al.	379/037
	E US-			
	F US-			
	G US-			
	H US-			
	I US-			
	J US-			
	K US-			
	L US-			
	M US-			

FOREIGN PATENT DOCUMENTS

*	Document Number Country Code-Number-Kind Code	Date MM-YYYY	Country	Name	Classification
	N				
	O				
	P				
	Q				
	R				
	S				
	T				

NON-PATENT DOCUMENTS

*	Document Number Country Code-Number-Kind Code	Date MM-YYYY	Country	Name	Classification
	U	Include as applicable: Author, Title Date, Publisher, Edition or Volume, Pertinent Pages)			
	V				
	W				
	X				

*A copy of this reference is not being furnished with this Office action. (See MPEP § 707.05(a).)
Dates in MM-YYYY format are publication dates. Classifications may be US or foreign.

<i>Index of Claims</i> 	Application/Control No. 13311448	Applicant(s)/Patent Under Reexamination WOOD ET AL.
	Examiner JOSHUA JOO	Art Unit 2445

✓	Rejected	-	Cancelled	N	Non-Elected	A	Appeal
=	Allowed	÷	Restricted	I	Interference	O	Objected

Claims renumbered in the same order as presented by applicant
 CPA
 T.D.
 R.1.47

CLAIM		DATE							
Final	Original	04/21/2012							
	1	✓							
	2	✓							
	3	✓							
	4	✓							
	5	✓							
	6	✓							
	7	✓							
	8	✓							
	9	✓							
	10	✓							
	11	✓							
	12	✓							
	13	✓							
	14	✓							
	15	✓							
	16	✓							
	17	✓							
	18	✓							
	19	✓							
	20	✓							

INFORMATION DISCLOSURE STATEMENT BY APPLICANT (Not for submission under 37 CFR 1.99)	Application Number			
	Filing Date		2011-12-05	
	First Named Inventor	Wood, et al.		
	Art Unit			
	Examiner Name			
	Attorney Docket Number		ENIT 9834C2	

U.S. PATENTS						Remove
Examiner Initial*	Cite No	Patent Number	Kind Code ¹	Issue Date	Name of Patentee or Applicant of cited Document	Pages, Columns, Lines where Relevant Passages or Relevant Figures Appear
	1					

If you wish to add additional U.S. Patent citation information please click the Add button. Add

U.S. PATENT APPLICATION PUBLICATIONS						Remove
Examiner Initial*	Cite No	Publication Number	Kind Code ¹	Publication Date	Name of Patentee or Applicant of cited Document	Pages, Columns, Lines where Relevant Passages or Relevant Figures Appear
	1					

If you wish to add additional U.S. Published Application citation information please click the Add button. Add

FOREIGN PATENT DOCUMENTS								Remove
Examiner Initial*	Cite No	Foreign Document Number ³	Country Code ² i	Kind Code ⁴	Publication Date	Name of Patentee or Applicant of cited Document	Pages, Columns, Lines where Relevant Passages or Relevant Figures Appear	T ⁵
	1	441720	JP		2000-08-18			<input type="checkbox"/>
	2	0030379	WO		2000-05-25			<input type="checkbox"/>
	3	9605678	WO		1996-02-22			<input type="checkbox"/>

INFORMATION DISCLOSURE STATEMENT BY APPLICANT (Not for submission under 37 CFR 1.99)	Application Number		13311448 - GAU: 2445	
	Filing Date		2011-12-05	
	First Named Inventor	Wood, et al.		
	Art Unit			
	Examiner Name			
	Attorney Docket Number		ENIT 9834C2	

4	9849661	WO		1998-11-05			<input type="checkbox"/>
5	0145061	WO		2001-06-21			<input type="checkbox"/>
6	0157724	WO		2001-08-09			<input type="checkbox"/>
7	0189150	WO		2001-11-22			<input type="checkbox"/>
8	0371392	WO		2003-08-28			<input type="checkbox"/>
9	0377063	WO		2003-09-18			<input type="checkbox"/>
10	0579421	WO		2005-09-01			<input type="checkbox"/>
11	0915598	EP		1999-09-12			<input type="checkbox"/>
12	1032148	EP		2000-08-30			<input type="checkbox"/>
13	1071296	EP		2001-01-24			<input type="checkbox"/>
14	1515512	EP		2005-03-16			<input type="checkbox"/>

INFORMATION DISCLOSURE STATEMENT BY APPLICANT (Not for submission under 37 CFR 1.99)	Application Number		13311448 - GAU: 2445
	Filing Date		2011-12-05
	First Named Inventor	Wood, et al.	
	Art Unit		
	Examiner Name		
	Attorney Docket Number		ENIT 9834C2

If you wish to add additional Foreign Patent Document citation information please click the Add button			Add
NON-PATENT LITERATURE DOCUMENTS			Remove
Examiner Initials*	Cite No	Include name of the author (in CAPITAL LETTERS), title of the article (when appropriate), title of the item (book, magazine, journal, serial, symposium, catalog, etc), date, pages(s), volume-issue number(s), publisher, city and/or country where published.	T ⁵
	1	3rd Generation Partnership Project TS 23.246, Release 6, September 2004	<input type="checkbox"/>
	2	Bharat Sanchar Nigam Limited, "Value Added Services in GSM", Engineering Instruction, 04 May 2005; http://www.bsnl.co.in/service/mobile voice based service.htm	<input type="checkbox"/>
	3	British Parliament Debates CellAlert Service for the UK, May 13, 2003, www.ceasa.us/news.htm	<input type="checkbox"/>
	4	Canadian Contract No. 5007441, 23 July 2003; http://72.14.203.104/search?q=cache:piSqEswBv74J:strategis.ic.gc.ca/epic/internet/inet-td	<input type="checkbox"/>
	5	Canadians want Emergency-Location Services, by Dave Ebner, April 11, 2003, www.ceasa.us/news.htm	<input type="checkbox"/>
	6	CEASA, "Cell Alert System Via Cell Broadcast, Wood, September 2005, www.eglobalconf.net/speeches/MarkWood.ppt	<input type="checkbox"/>
	7	CEASA; News and Events, "News", 14 January 2005-June 2005, http://www.ceasa-international.org/news.html	<input type="checkbox"/>
	8	CEASA, "Text Message Broadcasts Could Provide Disaster Alerts" 28 July 2005, http://ceasa-international.com/usa/index2.php?option=comcontent&task=view&id=1&Ite	<input type="checkbox"/>
	9	CEASA International, "Public Warnings Via Cell Broadcast". Wood and Weiser, 24 May 2005, http://www.ceasa-int.org	<input type="checkbox"/>

INFORMATION DISCLOSURE STATEMENT BY APPLICANT (Not for submission under 37 CFR 1.99)	Application Number	13311448 - GAU: 2445
	Filing Date	2011-12-05
	First Named Inventor	Wood, et al.
	Art Unit	
	Examiner Name	
	Attorney Docket Number	ENIT 9834C2

10	CEASA International, "Welcome to CEASa USA", Ceasa Admin, 12 June 2004, http://ceasa-international.com	<input type="checkbox"/>
11	Cellular Emergency Alert Services Association, Febraury 21, 2003, CellAlert Services Corporate Structure, www.ceasa.us/news.htm	<input type="checkbox"/>
12	Chinese Office Action (page 1 with cited reference EP 1032148) October 23, 2009	<input type="checkbox"/>
13	CSEC "wireless Implementation & Maintenance, Service Notification & Testing Notification Policies and Procedures", 19 April 2002, http://www.911.state.tx.us/files/pdfs/resources/call_take.xls	<input type="checkbox"/>
14	Deaf Today, "Disability Group Backs Cingular/AWS Merger, Silva, 04 June 2004, http://www.deaftoday.com/news/archives/004848.html	<input type="checkbox"/>
15	Engadget, "Dutch Testing Geo-Targeted SMS Emergency Broadcast System", Ricker, 08 October 2005, http://engadget.com/entry/12340005900692252	<input type="checkbox"/>
16	ETSI TS 123.246, Universal Mobile Telecommunications Systems (UMTS); Multimedia Broadcast/Multicast Service (MBMS); Architecture and functional description (3GPP TS 23.246 version 6.6.0 Release 6) (2005-03)	<input type="checkbox"/>
17	Global Amateur Radio Emergency Communications Conference, Tampere, Finland, 13-14 June 2005, "What is 'Cell Broadcasting' and Why do I care, as a HAM?", Wood, www.rientola.fi/oh3ag/garec/documents/Cellalert.ppt	<input type="checkbox"/>
18	International Search Report, date of mailing July 17, 2006 received from the International Searching Authority	<input type="checkbox"/>
19	International Telecommunication Union, "Cell Broadcast Broker System" M. Wood, Cell Alert Services Corp., 18 Feb 2003, http://www.itu.int/itudoc/itu-t/workshop/ets/isd3-001.html	<input type="checkbox"/>
20	Messaging Network, Bercut Limited, "Broadcast for the Masses", Sergey Ermilov, 2 March 2005, http://www.bercut.biz	<input type="checkbox"/>

INFORMATION DISCLOSURE STATEMENT BY APPLICANT (Not for submission under 37 CFR 1.99)	Application Number		13311448 - GAU: 2445
	Filing Date		2011-12-05
	First Named Inventor	Wood, et al.	
	Art Unit		
	Examiner Name		
	Attorney Docket Number		ENIT 9834C2

21	MobileIN.com Perspective, "Cell Broadcasting Technical Primer", Wood, September 2005, http://www.mobilein.com/Perspectives/Authors/CB_Primer.htm	<input type="checkbox"/>
22	MobileIN.com Perspective, "History and Importance of Cell Broadcast", Wood, September 2005, http://www.mobilein.com/Perspectives/Authors/CB_HistoryImportance.htm	<input type="checkbox"/>
23	News from Senator John Edwards, North Carolina, April 3, 2003, Senate Okays Edwards Emergency Warning Bill, www.ceasa.us/news.htm	<input type="checkbox"/>
24	Newscientist.com, "Text Message Broadcasts Could Provide Disaster Alerts", 06 January 2005, http://www.newscientist.com/article.ns?id=dn6852	<input type="checkbox"/>
25	OCG-EMTEL Archives, "Cell Broadcast Public Demonstration in USA Successful", Wood, 19 September 2004, http://list.etsi.fr/scripts/wa.exe?A2=ind0409&L=ocg_emptel&T=O&F=&S=&P=693	<input type="checkbox"/>
26	RCR, Cell-Broadcast Service Gets Second Look, Jeffrey Silva, November 10, 2003, www.ceasa.us/news.htm	<input type="checkbox"/>
27	Recommendation 12 (WTDC-02), The World Telecommunication Development Conference (Instabul 2002)	<input type="checkbox"/>
28	SMS News, "Text Message Broadcasts Could Provide Disaster Alerts", 07 January 2005, http://www.sendsmsnow.com/newspage.php?id=44	<input type="checkbox"/>
29	Stanford Univeristy, EE179 "Introduction to Communications, Professor Andrea Goldsmith, Winter 2005, http://www.stanford.edu/class/ee179	<input type="checkbox"/>
30	TeliaSonera, "Mobile Broadcast/Multicast Service (MBMS)", MediaLab, August 2004, www.medialab.sonera.fi	<input type="checkbox"/>
31	Text Message Warns of "killer flu" hot spots, April 20, 2003, www.ceasa.us/news.htm	<input type="checkbox"/>

INFORMATION DISCLOSURE STATEMENT BY APPLICANT (Not for submission under 37 CFR 1.99)	Application Number		13311448 - GAU: 2445
	Filing Date		2011-12-05
	First Named Inventor	Wood, et al.	
	Art Unit		
	Examiner Name		
	Attorney Docket Number		ENIT 9834C2

	32	The Cellular Emergency Alert Services Association Policy Statement, August 5, 2002, http://www.ceasa.us/news.htm	<input type="checkbox"/>
	33	The Wall Street Journal Online, Local Governments Look to Cellphone-Based Alerts, Carl Bialik, June 12, 2003, www.ceasa.us/news.htm	<input type="checkbox"/>

If you wish to add additional non-patent literature document citation information please click the Add button **Add**

EXAMINER SIGNATURE

Examiner Signature	/Joshua Joo/	Date Considered	04/23/2012
--------------------	--------------	-----------------	------------

*EXAMINER: Initial if reference considered, whether or not citation is in conformance with MPEP 609. Draw line through a citation if not in conformance and not considered. Include copy of this form with next communication to applicant.

¹ See Kind Codes of USPTO Patent Documents at www.USPTO.GOV or MPEP 901.04. ² Enter office that issued the document, by the two-letter code (WIPO Standard ST.3). ³ For Japanese patent documents, the indication of the year of the reign of the Emperor must precede the serial number of the patent document. ⁴ Kind of document by the appropriate symbols as indicated on the document under WIPO Standard ST.16 if possible. ⁵ Applicant is to place a check mark here if English language translation is attached.

INFORMATION DISCLOSURE STATEMENT BY APPLICANT (Not for submission under 37 CFR 1.99)	Application Number		13311448 - GAU: 2445
	Filing Date		2011-12-05
	First Named Inventor	Wood, et al.	
	Art Unit		
	Examiner Name		
	Attorney Docket Number		ENIT 9834C2

CERTIFICATION STATEMENT

Please see 37 CFR 1.97 and 1.98 to make the appropriate selection(s):

That each item of information contained in the information disclosure statement was first cited in any communication from a foreign patent office in a counterpart foreign application not more than three months prior to the filing of the information disclosure statement. See 37 CFR 1.97(e)(1).

OR

That no item of information contained in the information disclosure statement was cited in a communication from a foreign patent office in a counterpart foreign application, and, to the knowledge of the person signing the certification after making reasonable inquiry, no item of information contained in the information disclosure statement was known to any individual designated in 37 CFR 1.56(c) more than three months prior to the filing of the information disclosure statement. See 37 CFR 1.97(e)(2).

- See attached certification statement.
- The fee set forth in 37 CFR 1.17 (p) has been submitted herewith.
- A certification statement is not submitted herewith.

SIGNATURE

A signature of the applicant or representative is required in accordance with CFR 1.33, 10.18. Please see CFR 1.4(d) for the form of the signature.

Signature	/David L. Howard/	Date (YYYY-MM-DD)	2011-12-05
Name/Print	David L. Howard	Registration Number	41502

This collection of information is required by 37 CFR 1.97 and 1.98. The information is required to obtain or retain a benefit by the public which is to file (and by the USPTO to process) an application. Confidentiality is governed by 35 U.S.C. 122 and 37 CFR 1.14. This collection is estimated to take 1 hour to complete, including gathering, preparing and submitting the completed application form to the USPTO. Time will vary depending upon the individual case. Any comments on the amount of time you require to complete this form and/or suggestions for reducing this burden, should be sent to the Chief Information Officer, U.S. Patent and Trademark Office, U.S. Department of Commerce, P.O. Box 1450, Alexandria, VA 22313-1450. **DO NOT SEND FEES OR COMPLETED FORMS TO THIS ADDRESS. SEND TO: Commissioner for Patents, P.O. Box 1450, Alexandria, VA 22313-1450.**

Privacy Act Statement

The Privacy Act of 1974 (P.L. 93-579) requires that you be given certain information in connection with your submission of the attached form related to a patent application or patent. Accordingly, pursuant to the requirements of the Act, please be advised that: (1) the general authority for the collection of this information is 35 U.S.C. 2(b)(2); (2) furnishing of the information solicited is voluntary; and (3) the principal purpose for which the information is used by the U.S. Patent and Trademark Office is to process and/or examine your submission related to a patent application or patent. If you do not furnish the requested information, the U.S. Patent and Trademark Office may not be able to process and/or examine your submission, which may result in termination of proceedings or abandonment of the application or expiration of the patent.

The information provided by you in this form will be subject to the following routine uses:

1. The information on this form will be treated confidentially to the extent allowed under the Freedom of Information Act (5 U.S.C. 552) and the Privacy Act (5 U.S.C. 552a). Records from this system of records may be disclosed to the Department of Justice to determine whether the Freedom of Information Act requires disclosure of these records.
2. A record from this system of records may be disclosed, as a routine use, in the course of presenting evidence to a court, magistrate, or administrative tribunal, including disclosures to opposing counsel in the course of settlement negotiations.
3. A record in this system of records may be disclosed, as a routine use, to a Member of Congress submitting a request involving an individual, to whom the record pertains, when the individual has requested assistance from the Member with respect to the subject matter of the record.
4. A record in this system of records may be disclosed, as a routine use, to a contractor of the Agency having need for the information in order to perform a contract. Recipients of information shall be required to comply with the requirements of the Privacy Act of 1974, as amended, pursuant to 5 U.S.C. 552a(m).
5. A record related to an International Application filed under the Patent Cooperation Treaty in this system of records may be disclosed, as a routine use, to the International Bureau of the World Intellectual Property Organization, pursuant to the Patent Cooperation Treaty.
6. A record in this system of records may be disclosed, as a routine use, to another federal agency for purposes of National Security review (35 U.S.C. 181) and for review pursuant to the Atomic Energy Act (42 U.S.C. 218(c)).
7. A record from this system of records may be disclosed, as a routine use, to the Administrator, General Services, or his/her designee, during an inspection of records conducted by GSA as part of that agency's responsibility to recommend improvements in records management practices and programs, under authority of 44 U.S.C. 2904 and 2906. Such disclosure shall be made in accordance with the GSA regulations governing inspection of records for this purpose, and any other relevant (i.e., GSA or Commerce) directive. Such disclosure shall not be used to make determinations about individuals.
8. A record from this system of records may be disclosed, as a routine use, to the public after either publication of the application pursuant to 35 U.S.C. 122(b) or issuance of a patent pursuant to 35 U.S.C. 151. Further, a record may be disclosed, subject to the limitations of 37 CFR 1.14, as a routine use, to the public if the record was filed in an application which became abandoned or in which the proceedings were terminated and which application is referenced by either a published application, an application open to public inspections or an issued patent.
9. A record from this system of records may be disclosed, as a routine use, to a Federal, State, or local law enforcement agency, if the USPTO becomes aware of a violation or potential violation of law or regulation.

ALL REFERENCES CONSIDERED EXCEPT WHERE LINED THROUGH. /J.J./

UNITED STATES PATENT AND TRADEMARK OFFICE

 UNITED STATES DEPARTMENT OF COMMERCE
 United States Patent and Trademark Office
 Address: COMMISSIONER FOR PATENTS
 P.O. Box 1450
 Alexandria, Virginia 22313-1450
 www.uspto.gov

BIB DATA SHEET
CONFIRMATION NO. 9039

SERIAL NUMBER	FILING or 371(c) DATE	CLASS	GROUP ART UNIT	ATTORNEY DOCKET NO.		
13/311,448	12/05/2011	709	2445	ENIT 9834C2		
APPLICANTS Mark Andrew Wood, Haslemere, UNITED KINGDOM; Kevin Russell Preston, Newport, UNITED KINGDOM; Douglas Weiser, New Port Richey, FL;						
** CONTINUING DATA ***** This application is a CON of 12/559,405 09/14/2009 PAT 8,073,903 which is a CON of 11/057,704 02/14/2005 PAT 7,752,259 which claims benefit of 60/544,739 02/13/2004						
** FOREIGN APPLICATIONS *****						
** IF REQUIRED, FOREIGN FILING LICENSE GRANTED ** ** SMALL ENTITY ** 12/16/2011						
Foreign Priority claimed <input type="checkbox"/> Yes <input checked="" type="checkbox"/> No 35 USC 119(a-d) conditions met <input type="checkbox"/> Yes <input checked="" type="checkbox"/> No Verified and Acknowledged <u>/JOSHUA JOO/</u> <small>Examiner's Signature</small>		<input type="checkbox"/> Met after Allowance <small>Initials</small>	STATE OR COUNTRY UNITED KINGDOM	SHEETS DRAWINGS 11	TOTAL CLAIMS 20	INDEPENDENT CLAIMS 2
ADDRESS Polster, Lieder, Woodruff & Lucchesi, L.C. 12412 Powerscourt Dr. Suite 200 St. Louis, MO 63131-3615 UNITED STATES						
TITLE BROADCAST ALERTING MESSAGE AGGREGATOR/GATEWAY SYSTEM AND METHOD						
FILING FEE RECEIVED 595	FEES: Authority has been given in Paper No. _____ to charge/credit DEPOSIT ACCOUNT No. _____ for following:		<input type="checkbox"/> All Fees <input type="checkbox"/> 1.16 Fees (Filing) <input type="checkbox"/> 1.17 Fees (Processing Ext. of time) <input type="checkbox"/> 1.18 Fees (Issue) <input type="checkbox"/> Other _____ <input type="checkbox"/> Credit			

Doc code: IDS

Doc description: Information Disclosure Statement (IDS) Filed

13311448 - GAIL:2445

Approved for use through 07/31/2012. OMB 0851-0031

U.S. Patent and Trademark Office; U.S. DEPARTMENT OF COMMERCE

Under the Paperwork Reduction Act of 1995, no persons are required to respond to a collection of information unless it contains a valid OMB control number.

INFORMATION DISCLOSURE STATEMENT BY APPLICANT (Not for submission under 37 CFR 1.99)	Application Number		
	Filing Date		2011-12-05
	First Named Inventor	Wood, et al.	
	Art Unit		
	Examiner Name		
	Attorney Docket Number		ENIT 9834C2

U.S. PATENTS						Remove
Examiner Initial*	Cite No	Patent Number	Kind Code ¹	Issue Date	Name of Patentee or Applicant of cited Document	Pages, Columns, Lines where Relevant Passages or Relevant Figures Appear
	1	4415771		1983-11-15	Martinez	
	2	5278539		1994-01-11	Lauterbach, et al.	
	3	5592172		1997-01-07	Bailey, et al.	
	4	6021177		2000-02-01	Allport	
	5	6084510		2000-07-04	Lemelson, et al.	
	6	6112075		2000-08-29	Weiser	
	7	6169476	B1	2001-01-02	Flanagan	
	8	6219696	B1	2001-04-17	Wynblatt, et al.	

INFORMATION DISCLOSURE STATEMENT BY APPLICANT (Not for submission under 37 CFR 1.99)	Application Number		13311448 - GAU: 2445		
	Filing Date		2011-12-05		
	First Named Inventor	Wood, et al.			
	Art Unit				
	Examiner Name				
	Attorney Docket Number		ENIT 9834C2		

	9	6240360	B1	2001-05-29	Phelan	
	10	6346890	B1	2002-02-12	Belin	
	11	6463273	B1	2002-10-08	Day	
	12	6480578	B1	2002-11-12	Allport	
	13	6490525	B2	2002-12-03	Baron, Sr. et al.	
	14	6493633	B2	2002-12-10	Baron, Sr. et al.	
	15	6580916	B1	2003-06-17	Weisshaar, et al.	
	16	6650902	B1	2003-11-18	Richton	
	17	6683526	B2	2004-01-27	Bellin	
	18	6745021	B1	2004-06-01	Stevens	
	19	6751455	B1	2004-06-15	Acampora	

INFORMATION DISCLOSURE STATEMENT BY APPLICANT (Not for submission under 37 CFR 1.99)	Application Number		13311448 - GAU: 2445		
	Filing Date		2011-12-05		
	First Named Inventor	Wood, et al.			
	Art Unit				
	Examiner Name				
	Attorney Docket Number		ENIT 9834C2		

	20	6753784	B1	2004-06-22	Sznaider, et al.	
	21	6785551	B1	2004-08-31	Richard	
	22	6867688	B2	2005-03-15	Lamb	
	23	6882837	B2	2005-04-19	Fernandez, et al.	
	24	6947754	B2	2005-09-20	Ogasawara	
	25	4887308		1989-12-12	Dutton	
	26	6721542		2004-04-13	Anttila, et al.	
	27	6766163		2004-07-20	Sharma	

If you wish to add additional U.S. Patent citation information please click the Add button.

Add

U.S.PATENT APPLICATION PUBLICATIONS

Remove

Examiner Initial*	Cite No	Publication Number	Kind Code ¹	Publication Date	Name of Patentee or Applicant of cited Document	Pages, Columns, Lines where Relevant Passages or Relevant Figures Appear
	1	20020107016	A1	2002-08-08	Hanley	

INFORMATION DISCLOSURE STATEMENT BY APPLICANT (Not for submission under 37 CFR 1.99)	Application Number		13311448 - GAU: 2445	
	Filing Date		2011-12-05	
	First Named Inventor	Wood, et al.		
	Art Unit			
	Examiner Name			
	Attorney Docket Number		ENIT 9834C2	

	2	20020124252	A1	2002-09-05	Schafer, et al.	
	3	20020095333	A1	2002-07-18	Jokinen, et al.	
	4	20030026240	A1	2003-02-06	Eyuboglu, et al.	
	5	20030134622	A1	2003-07-17	Hsu, et al.	
	6	20030134651	A1	2003-07-17	Hsu	
	7	20030137415	A1	2003-07-24	Thomson	
	8	20030197615	A1	2003-10-23	Roche, et al.	
	9	20030145064	A1	2003-07-31	Hsu, et al.	
	10	20040150518	A1	2004-08-05	Phillips, et al.	
	11	20040152493	A1	2004-08-05	Phillips, et al.	
	12	20040247086	A1	2004-12-09	Menard, et al.	

INFORMATION DISCLOSURE STATEMENT BY APPLICANT (Not for submission under 37 CFR 1.99)	Application Number		13311448 - GAU: 2445		
	Filing Date		2011-12-05		
	First Named Inventor	Wood, et al.			
	Art Unit				
	Examiner Name				
	Attorney Docket Number		ENIT 9834C2		

	13	20050030977	A1	2005-02-10	Casey, et al.	
	14	20050162267	A1	2005-07-28	Khandelwal, et al.	
	15	20050096065	A1	2005-05-05	Fleischman	
	16	20050261012	A1	2005-11-24	Weiser	

If you wish to add additional U.S. Published Application citation information please click the Add button. **Add**

FOREIGN PATENT DOCUMENTS

Remove

Examiner Initial*	Cite No	Foreign Document Number ³	Country Code ² j	Kind Code ⁴	Publication Date	Name of Patentee or Applicant of cited Document	Pages, Columns, Lines where Relevant Passages or Relevant Figures Appear	T ⁵
	1	2000244427	JP		2000-09-08			<input type="checkbox"/>
	2	10336127	JP		1998-12-18			<input type="checkbox"/>
	3	441719	JP		1999-09-28			<input type="checkbox"/>
	4	09098140	JP		1997-04-08			<input type="checkbox"/>
	5	2000165826	JP		2000-06-16			<input type="checkbox"/>

If you wish to add additional Foreign Patent Document citation information please click the Add button **Add**

INFORMATION DISCLOSURE STATEMENT BY APPLICANT (Not for submission under 37 CFR 1.99)	Application Number		13311448 - GAU: 2445
	Filing Date		2011-12-05
	First Named Inventor	Wood, et al.	
	Art Unit		
	Examiner Name		
	Attorney Docket Number		ENIT 9834C2

NON-PATENT LITERATURE DOCUMENTS			Remove
Examiner Initials*	Cite No	Include name of the author (in CAPITAL LETTERS), title of the article (when appropriate), title of the item (book, magazine, journal, serial, symposium, catalog, etc), date, pages(s), volume-issue number(s), publisher, city and/or country where published.	T ⁵
	1		<input type="checkbox"/>
If you wish to add additional non-patent literature document citation information please click the Add button			Add
EXAMINER SIGNATURE			
Examiner Signature	/Joshua Joo/		Date Considered 04/23/2012
<p>*EXAMINER: Initial if reference considered, whether or not citation is in conformance with MPEP 609. Draw line through a citation if not in conformance and not considered. Include copy of this form with next communication to applicant.</p>			
<p>¹ See Kind Codes of USPTO Patent Documents at www.USPTO.GOV or MPEP 901.04. ² Enter office that issued the document, by the two-letter code (WIPO Standard ST.3). ³ For Japanese patent documents, the indication of the year of the reign of the Emperor must precede the serial number of the patent document. ⁴ Kind of document by the appropriate symbols as indicated on the document under WIPO Standard ST.16 if possible. ⁵ Applicant is to place a check mark here if English language translation is attached.</p>			

INFORMATION DISCLOSURE STATEMENT BY APPLICANT (Not for submission under 37 CFR 1.99)	Application Number		13311448 - GAU: 2445
	Filing Date		2011-12-05
	First Named Inventor	Wood, et al.	
	Art Unit		
	Examiner Name		
	Attorney Docket Number		ENIT 9834C2

CERTIFICATION STATEMENT

Please see 37 CFR 1.97 and 1.98 to make the appropriate selection(s):

That each item of information contained in the information disclosure statement was first cited in any communication from a foreign patent office in a counterpart foreign application not more than three months prior to the filing of the information disclosure statement. See 37 CFR 1.97(e)(1).

OR

That no item of information contained in the information disclosure statement was cited in a communication from a foreign patent office in a counterpart foreign application, and, to the knowledge of the person signing the certification after making reasonable inquiry, no item of information contained in the information disclosure statement was known to any individual designated in 37 CFR 1.56(c) more than three months prior to the filing of the information disclosure statement. See 37 CFR 1.97(e)(2).

See attached certification statement.

The fee set forth in 37 CFR 1.17 (p) has been submitted herewith.

A certification statement is not submitted herewith.

SIGNATURE

A signature of the applicant or representative is required in accordance with CFR 1.33, 10.18. Please see CFR 1.4(d) for the form of the signature.

Signature	/David L. Howard/	Date (YYYY-MM-DD)	2011-12-05
Name/Print	David L. Howard	Registration Number	41502

This collection of information is required by 37 CFR 1.97 and 1.98. The information is required to obtain or retain a benefit by the public which is to file (and by the USPTO to process) an application. Confidentiality is governed by 35 U.S.C. 122 and 37 CFR 1.14. This collection is estimated to take 1 hour to complete, including gathering, preparing and submitting the completed application form to the USPTO. Time will vary depending upon the individual case. Any comments on the amount of time you require to complete this form and/or suggestions for reducing this burden, should be sent to the Chief Information Officer, U.S. Patent and Trademark Office, U.S. Department of Commerce, P.O. Box 1450, Alexandria, VA 22313-1450. DO NOT SEND FEES OR COMPLETED FORMS TO THIS ADDRESS. **SEND TO: Commissioner for Patents, P.O. Box 1450, Alexandria, VA 22313-1450.**

Privacy Act Statement

The Privacy Act of 1974 (P.L. 93-579) requires that you be given certain information in connection with your submission of the attached form related to a patent application or patent. Accordingly, pursuant to the requirements of the Act, please be advised that: (1) the general authority for the collection of this information is 35 U.S.C. 2(b)(2); (2) furnishing of the information solicited is voluntary; and (3) the principal purpose for which the information is used by the U.S. Patent and Trademark Office is to process and/or examine your submission related to a patent application or patent. If you do not furnish the requested information, the U.S. Patent and Trademark Office may not be able to process and/or examine your submission, which may result in termination of proceedings or abandonment of the application or expiration of the patent.

The information provided by you in this form will be subject to the following routine uses:

1. The information on this form will be treated confidentially to the extent allowed under the Freedom of Information Act (5 U.S.C. 552) and the Privacy Act (5 U.S.C. 552a). Records from this system of records may be disclosed to the Department of Justice to determine whether the Freedom of Information Act requires disclosure of these records.
2. A record from this system of records may be disclosed, as a routine use, in the course of presenting evidence to a court, magistrate, or administrative tribunal, including disclosures to opposing counsel in the course of settlement negotiations.
3. A record in this system of records may be disclosed, as a routine use, to a Member of Congress submitting a request involving an individual, to whom the record pertains, when the individual has requested assistance from the Member with respect to the subject matter of the record.
4. A record in this system of records may be disclosed, as a routine use, to a contractor of the Agency having need for the information in order to perform a contract. Recipients of information shall be required to comply with the requirements of the Privacy Act of 1974, as amended, pursuant to 5 U.S.C. 552a(m).
5. A record related to an International Application filed under the Patent Cooperation Treaty in this system of records may be disclosed, as a routine use, to the International Bureau of the World Intellectual Property Organization, pursuant to the Patent Cooperation Treaty.
6. A record in this system of records may be disclosed, as a routine use, to another federal agency for purposes of National Security review (35 U.S.C. 181) and for review pursuant to the Atomic Energy Act (42 U.S.C. 218(c)).
7. A record from this system of records may be disclosed, as a routine use, to the Administrator, General Services, or his/her designee, during an inspection of records conducted by GSA as part of that agency's responsibility to recommend improvements in records management practices and programs, under authority of 44 U.S.C. 2904 and 2906. Such disclosure shall be made in accordance with the GSA regulations governing inspection of records for this purpose, and any other relevant (i.e., GSA or Commerce) directive. Such disclosure shall not be used to make determinations about individuals.
8. A record from this system of records may be disclosed, as a routine use, to the public after either publication of the application pursuant to 35 U.S.C. 122(b) or issuance of a patent pursuant to 35 U.S.C. 151. Further, a record may be disclosed, subject to the limitations of 37 CFR 1.14, as a routine use, to the public if the record was filed in an application which became abandoned or in which the proceedings were terminated and which application is referenced by either a published application, an application open to public inspections or an issued patent.
9. A record from this system of records may be disclosed, as a routine use, to a Federal, State, or local law enforcement agency, if the USPTO becomes aware of a violation or potential violation of law or regulation.

ALL REFERENCES CONSIDERED EXCEPT WHERE LINED THROUGH. /J.J./

Search Notes 	Application/Control No. 13311448	Applicant(s)/Patent Under Reexamination WOOD ET AL.
	Examiner JOSHUA JOO	Art Unit 2445

SEARCHED			
Class	Subclass	Date	Examiner
709	203-207	4/23/2012	/JJ/
455	403-404.1	4/23/2012	/JJ/

SEARCH NOTES		
Search Notes	Date	Examiner
Searched in EAST and searched classes/subclasses with keyword combinations. See attached search history.	4/23/2012	/JJ/
Performed Inventor search in PALM and EAST.	4/23/2012	/JJ/
Performed Assignee search in EAST.	4/23/2012	/JJ/

INTERFERENCE SEARCH			
Class	Subclass	Date	Examiner

	/J.J./ Primary Examiner. Art Unit 2445
--	---

EAST Search History

EAST Search History (Prior Art)

Ref #	Hits	Search Query	DBs	Default Operator	Plurals	Time Stamp
S4	11973	broadcast\$3 near10 (emergency alarm\$3 alert\$3 message\$1 notification\$1) same (area region location)	US-PGPUB; USPAT; EPO; JPO; IBM_TDB	OR	OFF	2012/04/19 11:53
S5	3043178	(authority authoriz\$3 authorization permit\$4 permission verif\$4 verification privileg\$4)	US-PGPUB; USPAT; EPO; JPO; IBM_TDB	OR	OFF	2012/04/19 11:54
S7	1156	S4 same S5	US-PGPUB; USPAT; EPO; JPO; IBM_TDB	OR	OFF	2012/04/19 11:54
S8	35689	709/203-207.ccls.	US-PGPUB; USPAT; EPO; JPO; IBM_TDB	OR	OFF	2012/04/19 11:54
S9	48	S7 and S8	US-PGPUB; USPAT; EPO; JPO; IBM_TDB	OR	OFF	2012/04/19 11:54
S10	116	"709"/\$.ccls. and S7	US-PGPUB; USPAT; EPO; JPO; IBM_TDB	OR	OFF	2012/04/19 11:55
S12	3828	455/403-404.1.ccls.	US-PGPUB; USPAT; EPO; JPO; IBM_TDB	OR	OFF	2012/04/19 11:55
S13	43	S7 and S12	US-PGPUB; USPAT; EPO; JPO; IBM_TDB	OR	OFF	2012/04/19 11:55
S14	362564	(authority authoriz\$3 authorization permit\$4 permission verif\$4 verification	US-PGPUB;	OR	OFF	2012/04/19 12:01

		privileg\$4) with (location\$1 area\$1 region\$1)	USPAT; EPO; JPO; IBM_TDB			
S15	426	S4 same S14	US- PGPUB; USPAT; EPO; JPO; IBM_TDB	OR	OFF	2012/04/19 12:01
S20	386	S7 and emergenc\$3 near5 (messag\$3 notification\$1 warn\$3 alert\$3)	US- PGPUB; USPAT; EPO; JPO; IBM_TDB	OR	OFF	2012/04/19 12:02
S21	50	S4 same jurisdiction	US- PGPUB; USPAT; EPO; JPO; IBM_TDB	OR	OFF	2012/04/19 12:22
S22	347198	(authority authoriz\$3 authorization permit\$4 permission verif\$4 verification privileg\$4) near10 (user requester official person agent)	US- PGPUB; USPAT; EPO; JPO; IBM_TDB	OR	OFF	2012/04/19 12:33
S23	189	S4 same S22	US- PGPUB; USPAT; EPO; JPO; IBM_TDB	OR	OFF	2012/04/19 12:33
S24	54	S23 and emergenc\$3 near5 (messag\$3 notification\$1 warn\$3 alert\$3)	US- PGPUB; USPAT; EPO; JPO; IBM_TDB	OR	OFF	2012/04/19 12:35
S25	283203	(authority authoriz\$3 authorization permit\$4 permission verif\$4 verification privileg\$4) near10 (area\$1 region\$1 location\$1)	US- PGPUB; USPAT; EPO; JPO; IBM_TDB	OR	OFF	2012/04/19 12:43
S26	285	S4 same S25	US- PGPUB; USPAT; EPO; JPO; IBM_TDB	OR	OFF	2012/04/19 12:43
S27	18178	emergenc\$3 near5 (messag\$3 notification\$1 warn\$3 alert\$3)	US- PGPUB; USPAT; EPO; JPO; IBM_TDB	OR	OFF	2012/04/19 12:43
S28	108	S26 and S27	US- PGPUB;	OR	OFF	2012/04/19 12:43

EAST Search History

			USPAT; EPO; JPO; IBM_TDB			
S29	5312	broadcast\$3 near10 (emergency alarm\$3 alert\$3 message\$1 notification\$1) near10 (area region location)	US-PGPUB; USPAT; EPO; JPO; IBM_TDB	OR	OFF	2012/04/19 13:18
S30	73574	(authority authoriz\$3 authorization permission verif\$4 verification privileg\$4) near10 (area\$1 region\$1 location\$1)	US-PGPUB; USPAT; EPO; JPO; IBM_TDB	OR	OFF	2012/04/19 13:18
S31	99	S29 same S30	US-PGPUB; USPAT; EPO; JPO; IBM_TDB	OR	OFF	2012/04/19 13:18
S32	41343	(authority authoriz\$3 authorization permission verif\$4 verification privileg\$4) near10 (city state country)	US-PGPUB; USPAT; EPO; JPO; IBM_TDB	OR	OFF	2012/04/19 13:29
S33	57910	broadcast\$3 near10 (emergency alarm\$3 alert\$3 message\$1 notification\$1)	US-PGPUB; USPAT; EPO; JPO; IBM_TDB	OR	OFF	2012/04/19 13:29
S34	106	S32 same S33	US-PGPUB; USPAT; EPO; JPO; IBM_TDB	OR	OFF	2012/04/19 13:29
S35	3433	(authority authoriz\$3 authorization permission verif\$4 verification privileg\$4) near10 (national regional)	US-PGPUB; USPAT; EPO; JPO; IBM_TDB	OR	OFF	2012/04/19 14:12
S36	21	S35 same S33	US-PGPUB; USPAT; EPO; JPO; IBM_TDB	OR	OFF	2012/04/19 14:12
S37	111077	(authority credential\$1 authoriz\$3 authorization permission verif\$4 verification privileg\$4) near10 (area\$1 region\$1 location\$1 city state national regional)	US-PGPUB; USPAT; EPO; JPO; IBM_TDB	OR	OFF	2012/04/19 14:31
S38	8957	broadcast\$3 near10 (emergency alarm\$3 alert\$3)	US-PGPUB;	OR	OFF	2012/04/19 14:31

			USPAT; EPO; JPO; IBM_TDB			
S39	1133	S37 and S38	US- PGPUB; USPAT; EPO; JPO; IBM_TDB	OR	OFF	2012/04/19 14:31
S40	98	"709"/\$.cls. and S39	US- PGPUB; USPAT; EPO; JPO; IBM_TDB	OR	OFF	2012/04/19 14:31
S41	221	"455"/\$.cls. and S39	US- PGPUB; USPAT; EPO; JPO; IBM_TDB	OR	OFF	2012/04/19 14:32
S42	306	S40 S41	US- PGPUB; USPAT; EPO; JPO; IBM_TDB	OR	OFF	2012/04/19 14:32
S52	271	broadcast\$3 near10 (messag\$3 notification\$1 emergency alarm\$3 alert\$3) same language\$1 and broadcast\$3 near10 (emergency alarm\$3 alert\$3 warn\$3)	US- PGPUB; USPAT; EPO; JPO; IBM_TDB	OR	OFF	2012/04/19 17:07
S54	82	broadcast\$3 near10 (messag\$3 notification\$1 emergency alarm\$3 alert\$3) same (different multiple plurality) near2 languages	US- PGPUB; USPAT; EPO; JPO; IBM_TDB	OR	OFF	2012/04/19 17:29
S57	815	(authority authoriz\$3 authorization permit\$4 permission authenticat\$4 verification privileg\$4) with (location\$1 area\$1 region\$1 geographic\$4) same (send\$3 transmit\$4) near10 (alert\$3 alarm\$3 message\$1 notification\$1) near10 (area region city country)	US- PGPUB; USPAT; EPO; JPO; IBM_TDB	OR	OFF	2012/04/20 14:10
S58	98	"709"/\$.cls. and S57	US- PGPUB; USPAT; EPO; JPO; IBM_TDB	OR	OFF	2012/04/20 14:10
S59	235	"455"/\$.cls. and S57	US- PGPUB; USPAT; EPO; JPO; IBM_TDB	OR	OFF	2012/04/20 14:16
S60	18178	emergenc\$3 near5 (messag\$3	US-	OR	OFF	2012/04/20

		notification\$1 warn\$3 alert\$3)	PGPUB; USPAT; EPO; JPO; IBM_TDB			14:50
S61	2206	(authority authoriz\$3 authorization permit\$4 permission authenticat\$4 verification privileg\$4) near10 (location\$1 area\$1 region\$1 geographic\$4) same (send\$3 transmit\$4) near10 (alert\$3 alarm\$3 message\$1 notification\$1) near10 (location\$1 area region geographic\$4 city country)	US- PGPUB; USPAT; EPO; JPO; IBM_TDB	OR	OFF	2012/04/20 14:51
S62	209	S60 and S61	US- PGPUB; USPAT; EPO; JPO; IBM_TDB	OR	OFF	2012/04/20 14:51
S68	50	("20020095333" "20020107016" "20020124252" "20030026240" "20030134622" "20030134651" "20030137415" "20030143974" "20030145064" "20030197615" "20040103158" "20040150518" "20040152493" "20040203562" "20040247086" "20040259568" "20050030977" "20050096065" "20050162267" "20050261012" "4415771" "5278539" "5592172" "5893091" "6021177" "6084510" "6112075" "6169476" "6219696" "6240360" "6346890" "6463273" "6480578" "6490525" "6493633" "6580916" "6650902" "6683526" "6745021" "6751455" "6753784" "6785551" "6867688" "6882837" "6947754" "7049971" "7184744" "7194249").PN. OR ("7752259").URPN.	US- PGPUB; USPAT; USOCR	OR	OFF	2012/04/20 15:19
S70	33	S68 and (authority authoriz\$3 authorization permit\$4 permission authenticat\$4 verification privileg\$4)	US- PGPUB; USPAT; EPO; JPO; IBM_TDB	OR	OFF	2012/04/20 15:19
S71	8	S68 and validat\$5	US- PGPUB; USPAT; EPO; JPO; IBM_TDB	OR	OFF	2012/04/20 15:33
S75	212	emergenc\$3 near5 (messag\$3 notification\$1 warn\$3 alert\$3) and (request\$3 message\$1) near10 channel near2 (type\$1 code\$1)	US- PGPUB; USPAT; EPO; JPO; IBM_TDB	OR	OFF	2012/04/21 12:46
S81	153	emergenc\$3 near5 (messag\$3 notification\$1 warn\$3 alert\$3) same (request\$3 message\$1) near5 (indicat\$4 specif\$4 identif\$4) near10 type\$1 near2	US- PGPUB; USPAT; EPO;	OR	OFF	2012/04/21 13:03

		(network message notification\$1)	JPO; IBM_TDB			
S82	119	broadcast\$3 same emergenc\$3 near5 (messag\$3 notification\$1 warn\$3 alert\$3) same (request\$3 message\$1) near10 type\$1 near2 (network message notification\$1)	US- PGPUB; USPAT; EPO; JPO; IBM_TDB	OR	OFF	2012/04/21 13:05
S84	143	broadcast\$3 same emergenc\$3 near10 (messag\$3 warn\$3 notification\$3 alert\$3) and request\$3 near10 (broadcast\$3 notification\$1 message\$1) same type near5 (alert\$3 broadcast\$3 notification\$1 messag\$3 warn\$3)	US- PGPUB; USPAT; EPO; JPO; IBM_TDB	OR	OFF	2012/04/23 08:41
S85	18	mark near2 andrew near2 wood.in.	US- PGPUB; USPAT; EPO; JPO; IBM_TDB	OR	OFF	2012/04/23 08:42
S86	18	kevin near2 russell near2 preston.in.	US- PGPUB; USPAT; EPO; JPO; IBM_TDB	OR	OFF	2012/04/23 08:42
S87	21	douglas near2 weiser.in.	US- PGPUB; USPAT; EPO; JPO; IBM_TDB	OR	OFF	2012/04/23 08:42
S88	18	envisionit.as.	US- PGPUB; USPAT; EPO; JPO; IBM_TDB	OR	OFF	2012/04/23 08:46
S89	27	("4415771" "5278539" "5592172" "6021177" "6084510" "6112075" "6169476" "6219696" "6240360" "6346890" "6463273" "6480578" "6490525" "6493633" "6580916" "6650902" "6683526" "6745021" "6751455" "6753784" "6785551" "6867688" "6882837" "6947754" "4887308" "6721542" "6766163").pn.	US- PGPUB; USPAT; EPO; JPO; IBM_TDB	OR	OFF	2012/04/23 09:13
S90	16	("20020107016" "20020124252" "20020095333" "20030026240" "20030134622" "20030134651" "20030137415" "20030197615" "20030145064" "20040150518" "20040152493" "20040247086" "20050030977" "20050162267" "20050096065" "20050261012").pn.	US- PGPUB; USPAT; EPO; JPO; IBM_TDB	OR	OFF	2012/04/23 09:23

4/ 23/ 2012 9:27:13 AM

C:\Users\jjoo\Documents\EAST\Workspaces\13311448.wsp



UNITED STATES PATENT AND TRADEMARK OFFICE

UNITED STATES DEPARTMENT OF COMMERCE
United States Patent and Trademark Office
Address: COMMISSIONER FOR PATENTS
P.O. Box 1450
Alexandria, Virginia 22313-1450
www.uspto.gov

Table with 4 columns: APPLICATION NUMBER (13/311,448), FILING OR 371(C) DATE (12/05/2011), FIRST NAMED APPLICANT (Mark Andrew Wood), ATTY. DOCKET NO./TITLE (ENIT 9834C2)

CONFIRMATION NO. 9039

1688
Polster, Lieder, Woodruff & Lucchesi, L.C.
12412 Powerscourt Dr. Suite 200
St. Louis, MO 63131-3615

PUBLICATION NOTICE



Title: BROADCAST ALERTING MESSAGE AGGREGATOR/GATEWAY SYSTEM AND METHOD

Publication No. US-2012-0142307-A1

Publication Date: 06/07/2012

NOTICE OF PUBLICATION OF APPLICATION

The above-identified application will be electronically published as a patent application publication pursuant to 37 CFR 1.211, et seq. The patent application publication number and publication date are set forth above.

The publication may be accessed through the USPTO's publically available Searchable Databases via the Internet at www.uspto.gov. The direct link to access the publication is currently http://www.uspto.gov/patft/.

The publication process established by the Office does not provide for mailing a copy of the publication to applicant. A copy of the publication may be obtained from the Office upon payment of the appropriate fee set forth in 37 CFR 1.19(a)(1). Orders for copies of patent application publications are handled by the USPTO's Office of Public Records. The Office of Public Records can be reached by telephone at (703) 308-9726 or (800) 972-6382, by facsimile at (703) 305-8759, by mail addressed to the United States Patent and Trademark Office, Office of Public Records, Alexandria, VA 22313-1450 or via the Internet.

In addition, information on the status of the application, including the mailing date of Office actions and the dates of receipt of correspondence filed in the Office, may also be accessed via the Internet through the Patent Electronic Business Center at www.uspto.gov using the public side of the Patent Application Information and Retrieval (PAIR) system. The direct link to access this status information is currently http://pair.uspto.gov/. Prior to publication, such status information is confidential and may only be obtained by applicant using the private side of PAIR.

Further assistance in electronically accessing the publication, or about PAIR, is available by calling the Patent Electronic Business Center at 1-866-217-9197.

Office of Data Management, Application Assistance Unit (571) 272-4000, or (571) 272-4200, or 1-888-786-0101

IN THE UNITED STATES PATENT AND TRADEMARK OFFICE

Applicant: Wood, Mark Andrew, et al :
Serial No: 13/311,448 : Art Unit: 2445
Filed: December 5, 2011 : Examiner: Joo, Joshua
For: Broadcasting Alerting Message : Attorney Docket No: ENIT 9834C2
Aggregator/Gateway System and
Method

Mail Stop Amendment
Commissioner for Patents
P.O. Box 1450
Alexandria, Virginia 22313-1450

AMENDMENT A - RESPONSE TO OFFICE ACTION

Sir:

In response to the Office Action mailed April 24, 2012, please amend the application as follows and consider the remarks set forth below. Applicant hereby petitions under the provisions of 37 C.F.R. § 1.136(a) for an extension of time in which to respond to the outstanding Office Action and includes a fee as set forth in 37 C.F.R. § 1.17(a) with this response for such extension of time.

Amendments to the Claims begin on page 2 of this paper.

Remarks begin on page 7 of this paper.

AMENDMENTS TO THE CLAIMS

The following listing of claims will replace all prior versions and listings of claims in the application.

LISTING OF CLAIMS

1. (Currently amended) A message alert broadcast broker system for providing a broadcast message to a plurality of user devices located within a geographically defined broadcast target area, the system comprising:

a broadcast service bureau communicatively coupled for receiving from one of a plurality of coupled broadcast agent access systems providing a broadcast request from an originating broadcast agent associated one broadcast agent message origination systems, the broadcast request including a broadcast agent identification, the geographically defined broadcast target area, and a broadcast message, the broadcast service bureau having a stored geographically defined broadcast message jurisdiction for the originating broadcast agent and configured for verifying the broadcast request as a function of the broadcast agent identification including an authority of the originating broadcast agent to send the broadcast message to the broadcast target area by comparing the stored geographically defined broadcast message jurisdiction for the originating broadcast agent with the broadcast target area associated with the broadcast message in the broadcast request,

the broadcast service bureau processing the verified broadcast request for transmission to one or more broadcast message networks providing broadcast message alerting service to at least a portion of the broadcast target area.

2. (Currently amended) The system of claim 1 wherein the broadcast service bureau is configured for receiving the broadcast request, and identifying the one or more broadcast message networks from among a plurality of coupled broadcast message networks, providing message alerting service to at least a portion of the broadcast target area.

3. (Currently amended) The system of claim 2 wherein the one or more message broadcast message networks includes at least one point-to-multipoint non-subscription wireless broadcast network selected from the group consisting of wireless mobile carrier network, and wireless Wi-Fi network, and at least one other broadcast message network selected from the group consisting of digital private radio systems operator network, private radio system network, internet service provider networks, wireline telecommunication network, satellite network, CATV network, radio system, and television system.

4. (Original) The system of claim 1 wherein the broadcast service bureau further includes a distributor receiving the broadcast message and broadcast target area and mapping the broadcast target area to determine which one or more of the broadcast message networks from among a plurality of broadcast message networks has a broadcast message distribution system serving at least a portion of the broadcast target area, and wherein the distributor identifies the one or more broadcast message networks.

5. (Currently amended) The system of claim 4 wherein the one or more message broadcast message networks includes at least one point-to-multipoint non-subscription wireless broadcast network selected from the group consisting of wireless mobile carrier network, and wireless Wi-Fi network, and at least one other broadcast message network selected from the group consisting of digital private radio systems operator network, private radio system network, internet service provider networks, wireline telecommunication network, satellite network, CATV network, radio system, and television system.

6. (Original) The system of claim 1 wherein the broadcast service bureau includes an output interface for coupling to one of the one or more broadcast message networks providing message alerting service to at least a portion of the broadcast target area.

7. (Currently amended) The system of claim 6 wherein the output interface is configured to interface ~~with a message~~ with at least one point-to-multipoint non-subscription broadcast message network selected from the group consisting of wireless mobile carrier network, and wireless Wi-Fi network, and at least one other broadcast message networks selected from the

group consisting of digital private radio systems operator network, private radio system network, internet service provider networks, wireline telecommunication network, satellite network, CATV network, radio system, and television system.

8. (Currently amended) The system of claim 1 wherein the broadcast service bureau includes a memory for storing a geographically defined broadcast message jurisdiction for each of a plurality of broadcast agents for each of the coupled broadcast agent access systems and identifies the originating broadcast agent from among the plurality of broadcast agents, verifies an the authority of the originating broadcast agent to transmit the broadcast message of the broadcast request to the broadcast target area of the broadcast request as a function of the comparing a broadcast message jurisdiction stored in the broadcast service bureau for the originating broadcast agent, the verifying ensuring that the geographically defined broadcast message jurisdiction of the originating broadcast agent includes the broadcast target area for the broadcast message of the broadcast request.

9. (Currently amended) The system of claim 6 wherein the output interface is configured for interfacing with a carrier broadcast center of a wireless mobile carrier network, the carrier broadcast center receiving the broadcast message and the broadcast target area from the broadcast service bureau and converting the broadcast target area to network addresses of point-to-multipoint wireless transmission devices serving the broadcast target area including determining particular point-to-multipoint wireless network transmission devices serving at least a portion of the broadcast target area, and identifying the network addresses for each determined particular wireless transmission device and transmitting the broadcast message to the network addresses of the particular point-to-multipoint wireless transmission devices for point-to-multipoint wireless transmission of the broadcast message by the particular point-to-multipoint wireless transmission devices to user receiving devices.

10. (Currently amended) The system of claim 9 wherein the point-to-multipoint wireless transmission devices serving the broadcast target area and the particular wireless transmission devices are wireless cellular network transmitters and each of the wireless cellular

network transmitters has a cell id network address and the identified network addresses are cell id network addresses.

11. (Currently amended) The system of claim 9 wherein the point-to-multipoint wireless transmission devices serving the broadcast target area and the particular wireless transmission devices are Wi-Fi network transmitters, each of the Wi-Fi network transmitters having a Wi-Fi id network address, wherein the identified network addresses are Wi-Fi id network addresses.

12. (Original) The system of claim 1 wherein the broadcast request includes a message type identifying the type of message of the broadcast message request.

13. (Original) The system of claim 1 wherein the broadcast request includes a broadcast message that is an alerting system administrative message selected from the group consisting of: message recall, language identifier, network selector, and request for message progress status.

14. (Currently amended) The system of claim 1 wherein the broadcast message of the broadcast request is a first broadcast message, the first broadcast message being in a first language, and wherein the broadcast request includes a second broadcast message in a second language, and wherein the broadcast service bureau is configured associate the first broadcast message with a first broadcast message channel identifier and the second broadcast message with a second broadcast message channel identifier that is different than the first broadcast message channel identifier to transmit ~~the broadcast request including at least one of the first~~ broadcast message in the first language with the first broadcast channel identifier and the second broadcast message in the second language with the second broadcast channel identifier.

15. (Original) The system of claim 1 wherein the broadcast message is a multimedia message.

16. (Original) The system of claim 15 wherein the multimedia message includes at least one of a photograph and a map.

17. (Original) The system of claim 1 wherein the broadcast request includes a message type.

18. (Currently amended) The system of claim 17 wherein the broadcast service bureau is coupled to a plurality of broadcast message networks, and is configured to select the one or more broadcast message networks from among the plurality of coupled broadcast message networks responsive to ~~at least of~~ the message type and the broadcast target area.

19. (Currently amended) A method of public service broadcast messaging to a broadcast target area, the method comprising:

receiving over an input interface a broadcast request including a broadcast agent identification, a geographically defined broadcast target area, and a broadcast message from one of a plurality of coupled broadcast agent message origination systems;

storing a geographically defined broadcast message jurisdiction for a broadcast agent;

verifying an authority of the broadcast agent identification including an authority of the originating broadcast agent to send the broadcast message to the broadcast target area by comparing the stored geographically defined broadcast message jurisdiction for the originating broadcast agent with the broadcast target area associated with the broadcast message in the broadcast request; and

transmitting the broadcast message over an output interface to one or more coupled broadcast message networks providing broadcast message alerting service to at least a portion of the broadcast target area.

20. (Currently amended) The method of claim 19 wherein the broadcast request includes a message type, further comprising:

selecting ~~the~~ one or more point-to-multipoint non-subscription wireless mobile device broadcast message networks from among the plurality of coupled broadcast message networks responsive to ~~at least of~~ the message type and the broadcast target area wherein transmitting includes at least one of the selected point-to-multipoint non-subscription wireless mobile device broadcast message networks.

REMARKS

Claims 1-20 are now pending in the application.

Claims 1, 2, 3, 5, 7-11, 14, and 18-20 have been amended by this Amendment.

The Examiner is respectfully requested to reconsider and withdraw the rejections in view of the amendments and remarks contained herein.

NONSTATUTORY OBVIOUSNESS-TYPE DOUBLE PATENTING

Claims 1-13 and 17-20 stand rejected under nonstatutory obviousness-type double patenting in view of claims 1-3, 5, 7 and 9 of co-owned U.S. Patent No. 8,073,903.

Applicants have submitted herewith a duly executed terminal disclaimer under 37 CFR 1.321(c) executed by the registered attorney of the Applicants as the cited '903 patent and the present patent application are commonly owned. As such, this rejection and the Obviousness rejections based in whole or in part on the '903 should be withdrawn.

Claims 1 and 19 stand rejected under nonstatutory obviousness-type double patenting in view of claims 1 and 10 of co-owned U.S. Patent No. 7,752,259. It is not clear as to what the Office has stated for the rejection of claim 19 in this regard as it is stated "Regarding claim 19, the claim is a method that corresponds to the system of claim 1. Therefore, the claim is is not rejected under a similar rational." (emphasis added). The Applicants are assuming that this was a type and that the word "not" was not intended to be included.

Applicants have submitted herewith a duly executed terminal disclaimer under 37 CFR 1.321(c) executed by the registered attorney of the Applicants as the cited '259 patent and the present patent application are commonly owned. As such, these rejections based on the '259 patent should be withdrawn.

AMENDMENTS TO THE CLAIMS

This Amendment further includes additional amendments to claims 1, 3, 5, 7-11, 14, and 18-20. Support for these amendments to the claims is provided as follows:

The Applicant have presented certain amendments to the claims as follows:

1. Service bureau stores geographically defined broadcast message jurisdiction for the broadcast agents that send it broadcast messages with message specific broadcast target areas. Claims 1 and 19. See Specification, Paras. 0061-0077, and in particular 0072.

2. the broadcast service bureau includes a memory for storing a geographically defined broadcast message jurisdiction for each of a plurality of broadcast agents for each of the coupled broadcast agent access systems and identifies the originating broadcast agent from among the plurality of broadcast agents. Claim 8.

3. verifying the broadcast request by comparing the stored geographically defined broadcast message jurisdiction for the originating broadcast agent with the broadcast target area associated with the broadcast message in the broadcast request. Claim 1 and 19. See Specification, Paras. 0131, as the jurisdictional area of the agent is a broadcast agent parameter, see 0072.

4. point-to-multipoint non-subscription wireless broadcast network. Claims 3, 5, 7, 9, 10, 11 and 20. These are generally described as cell broadcast technology which is contrasted in the specification as being point to multipoint as compared to the point to point messaging service of SMS as described in the Background. See Background as compared to Paras. 0191-193, 0041-045 as location broadcast channel technology.

5. the broadcast service bureau is configured associate the first broadcast message with a first broadcast message channel identifier and the second broadcast message with a second broadcast message channel identifier that is different than the first broadcast message channel identifier and to transmit the broadcast request including at least one of the first broadcast message in the first language with the first broadcast channel identifier and the second broadcast message in the second language with the second broadcast channel identifier. Claim 14. Specification, Paras. 0062, 0089, 0093-0095, 0106 (assignment of pre-assigned codes for each language), 0113, 0171, and Appendix 1, Para. 211, channel code assignments based on language channels 501-650).

Applicants do not believe that any new matter has been introduced and that all of these amendments are fully supported by the vast disclosure in the Specification to any person of ordinary skill in the art.

REJECTIONS UNDER 35 U.S.C. § 103

A. Claims 1-8, 12, 15-17 and 19 stand rejected under 35 U.S.C. § 103(a) as being unpatentable over U.S. Pub. No. 2004/0103158, issued to *Vella* et al (hereinafter *Vella*) in view of U.S. Pat. No. 6,480,578, issued to *Allport* (hereinafter *Allport*). This rejection is respectfully traversed.

As an initial matter, the *Vella* and the *Allport* references will be briefly reviewed, both alone for their individual disclosures and also their combination, e.g., the modification of *Vella* in view of *Allport*. The Applicants acknowledge that they cannot show nonobviousness by attacking these two references individually, however, a rejection based on 35 U.S.C. 103(a) must include a showing that in view of the combined references that all of the elements or limitations of the claim recitations are present in the combination such that the invention as a whole would have been obvious to one of ordinary skill in the art. As the combination of *Vella* and *Allport* fail to teach or disclose all of the recitations or elements recited by each of the claims as required by the first Graham factor for a finding of prima facie obviousness (See MPEP 2143.A(1) and 2143.03), the rejections based on the combination of *Vella* and *Allport* should be withdrawn.

As the Office actions base these rejections on *Vella* as a primary reference, the teachings and disclosure of *Vella* will first be reviewed. Then the teachings and disclosure of *Kolsrud* will be similarly reviewed. After this, the modification of *Vella* by *Allport*, *Kolsrud* and/or *Zimmers*, i.e., as suggested combination in of the Office, will be reviewed. As will be shown, *Vella* cannot be modified by *Allport* in support of a prima facie obviousness rejection. This being said, the Applicants will next review the claims of the present application in view of the suggested combination of *Vella* with *Allport* (hereinafter referred to as *Vella/Allport*).

Vella

Contrary to the description in the Office action, *Vella* does not teach or disclose substantially the invention as claimed in claims 1 and 19 as well as the specification generally.

In contrast to the present specification and claims, *Vella* discloses a cellular messaging alert method and system that is different than that recited by the claims in the present application. In fact, the present application describes in the Background Section (Specification, Paras. 0003-00021) a system and method that is similar to that disclosed by *Vella*. As noted, in the Background Section, the *Vella* based system has considerable limitations and problems, some of which are acknowledged in *Vella*. As identified in the present specification, those limitations are not present in the current claimed system. Specification, Paras. 0043 and 0044.

Vella's disclosed systems and methods use a web-based GUI interface that can include a basic rectangular mapping capability (*Vella*, Paras. 0042-0048), however, *Vella* discloses that the alert originator first selects a message target area or location, then the system determines the recipients of the alert based on the a query to a database that stores contact information including the telephone numbers of all of the subscribers or persons that have a home location within the defined message target area. *Vella*, Para. 0049 (emphasis added). The telephone numbers for each identified recipient having a home location in the message target area is determined by *Vella* from a database for use in transmitting the alert message to each individual recipient. *Vella*, Paras. 0058-0061. *Vella* also describes that the initial listing of recipients as identified by their telephone numbers can be added to or reduced based on information obtained from a mobile carriers Home Location Register (HLR) and/or Visitor Location Register (VLR) *Vella*, Para. 0065. *Vella* also teaches an alternative embodiment where the alert message is sent to the mobile carrier for transmission to each telephone number of a user within the HLR and VLR databases of the carrier. *Vella*, 0067.

Vella teaches that after the recipients of the message are determined by its system and method, an alert can be generated by the agent. *Vella*, Para. 0050, 0063-0064. The Alert message of *Vella* is generated, "launched" by a launch server by sending a file of all of the identified recipient telephone numbers to an short messaging service (SMS) system of a cellular carrier. *Vella*, Paras. 0069, 0078. The alert message, as taught by *Vella*, is individually transmitted on a point to point basis to each recipient by sending out individual SMS messages based on the individual recipient telephone numbers as required by SMS text messaging and as provided by the file sent from the *Vella* message server. *Vella*, Para. 0053, 0063-0064, 0079. As noted by *Vella*, this results in the mobile carrier having to process individual SMS text messages that can result, in an emergency situation, having hundreds of thousands or even millions of SMS

messages having to be processed by the SMS servers of the mobile carriers. See *Vella*, Para. 0079, and Specification, Paras. 0005-0021. Even in the alternative embodiment as described by *Vella*, the launch server merely transmits the file with all of the telephone numbers of the previously identified recipients to the mobile carrier for their internal processing using the SMS server's HLR/VLR databases to transmit the individual SMS messages to the telephone numbers as identified in the HLR/VLR databases of the carrier. *Vella*, Paras. 0080-0081.

In summary, *Vella* discloses identifying individual recipients by the 10-digit telephone number and then replicating the message for each and every recipient in the form of a point-to-point SMS text message sent via the 10-digit telephone number. *Vella* teaches that each recipient receives the alert message via the SMS text messaging capability of the handset.

Vella discloses an agent authorization process that is based on the alert originator entering a user name and password to verify the alert agent's authority. *Vella*, Para. 0056. *Vella* also discloses that this verification of each message can include a verbal identification code referred to as a "launch code" whereby once the user name, password and launch code are correctly entered, the alert message is transmitted to the phone numbers for each of the identified recipients. *Vella*, Paras 0056-0058. As correctly noted in the Office action, *Vella* does not provide any disclosure that validates or verifies that the originator of the message to be broadcast has authority to have the message broadcast to the target area for the particular message. *Vella* only discloses that the messaging agent has access authority to the messaging system such as a user login and a message launch code (user name, password and some additional code that is secret that is input to tell the system that the message can be transmitted. As such, it appears inherent in *Vella* that the messaging server must store user ids, passwords and also message launch codes.

Vella discloses a message broadcasting system (shown in Fig. 3 as 300) that uses a launch server with an apparent tie-in to a system database 335 "in order to determine the recipients for the alert within the defined area" *Id.*, Para. 0074. Only after determining the recipients does the *Vella* system web interface server 335 receive the message data from the alerting agency 305 or 310 to be included in the alert message. *Id.*, Para. 0075. Or in the alternative, the unformatted message is sent to the mobile carriers SMS point to point messaging server 355/357 to all cellular phones currently registered in the SMS server's HLR/VLR database 360. *Id.*, Para. 0080.

Allport

Allport discloses a communication system for notification of warnings. *Allport's* system monitors the telephone lines for specific codes that are sent out over the wireline network and upon receipt of a code, activates a visual or audio alerting notification. In other words, the wireless telephone network is configured to send alerting codes over the wirelines to activate the local notification device almost like a reverse home monitoring alarm system. To accomplish this, *Allport* discloses that the central office based system must identify each and every line that is located in the message or alert target area based on the telephone numbers and a storing of the location of the telephone devices based on their telephone numbers. As described, to anyone that knows anything about wireless telephone equipment, is very difficult if not impossible post number portability implementation as mandated by the FCC. A database of wireline numbers and their physical location has to be maintained, and are often complex back office systems used by telephone company maintenance and repair personnel. The telephone number has to be cross-referenced to a physical pair etc. Just like caller ID service, to generate a code over a telephone line, the local central office switch has to access the line via a modem or similar device to input or apply the code, just like the applying a ring tone power.

Allport does address to a limited degree the message creation and processing for alerting messages as identified, but really misidentified, by the Office. In Fig. 12, the *Allport* process includes entering postal codes and signal type in S120, and checking input authorization in S122 and authorization validation in S124. However, contrary to the reliance and misinterpretation in the Office action, *Allport* discloses that the authorized party must input some form of authorization (step S122) in order for processing to continue. *Allport*, Col. 13, lines 10-12. As taught, it is the agent that inputs authorization. *Allport* discloses that the authorization can depend on the system's intended scope, and use, and may include passwords, electronic or mechanical keys, magnetic cards, tokens or any other form of identification verification. *Id.*, lines 12-16. (emphasis added). In other words, *Allport* clearly discloses that its **verification is as to the identification of the party** inputting the message. *Id.* Only after the party is authenticated as to identification, does the authorized party communicate to the telephone company's switch equipment, those regions to be sent the coded message. *Id.* Lines 17-20. In other words, the identity of the party that is accessing the telephone central office switch, is

verified only for access to the CO switch. Once the CO switch is accessed, the party can enter the “target area” as the region for the alert coded signal to be sent as well as the type of signal to be sent. Id. Lines 10-24 and col. 14, lines 45-55. *Allport*, like *Vella*, merely includes a disclosure as to verifying that the accessing party is authorized to access the system or to send particular types of signals (*Allport*).

Vella/Allport

First, the Applicants note that the combination or modification of the SMS message broadcasting system of *Vella* by the alerting signal on a per-line basis of *Allport* is not a suitable combination in any manner. *Vella*'s discloses a messaging system that is based on sending SMS text or multimedia messages over a mobile network using the SMS messaging system. The alerting messages of *Vella* are used to query a database (HLR and VLR databases) to identify the telephone numbers of the mobile devices that happen to be in the target area at the particular time as they are mobile. The *Vella* system then transmits the identified telephone numbers to the SMS point to point messaging system so that the message is transmitted one at a time via the SMS messaging system to each provided telephone number. In contrast, the *Allport* system is a wireline based system that discloses that the manager or messaging agent has to access each central office switch, which inherently as known to anyone of any ordinary skill in the art, is already geographically allocated and defined and has been since the original telephone systems were implemented nearly 100 years ago. The *Allport* system requires that each central office switch be accessed and then each line serving a particular portion of the central office serving area is determined. Only then does a signal, not the message, but a coded signal, based on the type of message, is transmitted over the particular wireless lines, so as to activate the physical alerting device that is attached at the remote location. Anyone of any skill in the art would clearly understand that the wireless technologies of *Allport* are not compatible with or combinable with wireless mobile telephone systems and are clearly not combinable with SMS text messaging used with mobile carrier systems. When has the examiner been able to obtain and SMS message on a wireline telephone such as taught by *Allport*. These are two completely different technologies. That is why *Allport* merely sends an alert code over the wireline and one reason why implementation of calling number and calling name services were extremely difficult and costly in the wireline telephone systems, but were inherent in the mobile telephone systems.

They are completely different and not combinable technologies.

Second, contrary to the Office action, *Allport* does not teach any type of verification or authorization or validation as to whether a particular message as received from a particular broadcast agent, is verified that the particular sending or originating agent has the authority to send that particular message to the particular geographically defined target area. This capability is not taught by *Allport*, is not taught by *Vella* and is not taught by any other cited or known reference.

However, to be clear to the Office and this particular examiner, the Applicants have amended claims 1 and 19 to clarify the claimed verification process. As amended, claims 1 and 19 now recite that the message broadcast service bureau, which receives the broadcast request with the particular message to be broadcast and the geographically defined target area for that particular message to be broadcast into. This includes a comparison of a stored geographically defined broadcast message jurisdiction for the broadcast agent that originated the message against the target area for the particular message. As such, each broadcast request with each broadcast message and each associated target area, is compared against a predefined (stored) preauthorized geographical target area for the originated message agent. As described in the specification, each agent is preauthorized for sending messages only to his/her geographic area. See by way of example, Specification, Para. 0163. While the current system also include the identification verification of the agent as taught by *Vella* and *Allport* (See Specification, Para. 0200, for entering of a password, etc. The specification refers generally to this as the jurisdiction of the agent. *Id.* At 0029, 0060, 0072, 0081, 0082, 0112, 0163, 0179, and 0201. The Specification clearly and repeatedly describes this jurisdictional authorization of each agent based on each message to be sent to each particular target area for the message. This is not disclosed in *Vella/Allport* or any other references. None of the references or the combination of *Vella/Allport* disclose storing of a geographically defined broadcast message jurisdiction for an agent and then comparing the such stored agent jurisdiction to the target area of each message to ensure that that each message is being originated by an agent whom has authority to transmit and broadcast a message to the intended target area for the message.

For these reasons, claims 1 and 19, as originally submitted and also as amended herein, are not obvious in view of *Vella/Allport* or any other combination of any cited reference. As

such the rejections to claims 1 and 19 should be withdrawn and claims 1 and 19 placed in allowance. Further claims 2-18 depend from claim 1 and claim 20 depends from claim 19 and each of claims 2-18 and 20 are allowable due to their dependency from an allowable claim.

Claims 3, 5 and 7 as amended each recite 3. wherein the one or more message broadcast message networks to which the broadcast service bureau transmits the broadcast message includes at least one point-to-multipoint non-subscription wireless broadcast network selected from the group consisting of wireless mobile carrier network, and wireless Wi-Fi network, and at least one other broadcast message network selected from the group consisting of digital private radio systems operator network, private radio system network, internet service provider networks, wireline telecommunication network, satellite network, CATV network, radio system, and television system. This combination is not taught by any of the cited references. *Vella*, *Atkin* and *Kolsrud* address only an SMS messaging network for mobile carriers. *Zimmers* only address and IP internet systems but may also disclose a PSTN wireline system based on Fig. 1. And *Allport* addresses a wireline PSTN network. None of these references addresses a combination of a point to multipoint non-subscription messaging system that also includes a pure broadcast system as a secondary transmission network for the same message, all coordinated by the same broadcast service bureau. As such, claims 3, 5 and 7 are all allowable.

Claim 2 recites the broadcast service bureau is configured for receiving the broadcast request and identifying the one or more broadcast message networks providing message alerting service to at least a portion of the broadcast target area. The Office action states that *Vella* teaches this but such a reliance is not a correct or reasonable interpretation of *Vella* alone or in combination with *Allport*. The referenced paragraphs of *Vella* state in Para 0079 that the launch server 330 accesses the system database 335 in order to determine an address format that a particular cellular carrier 380 or 385 utilizes for receiving text messages. Thereafter, the launch server 330 formats the alert message to comply with an address format of a particular cellular carrier providing service to the recipients. The launch server 330 then sends the formatted messages to a public network (the Internet 320), for example via a Cisco router interface. With up to 40 Megs of burstable bandwidth, the launch server 330 can send up to 100,000 messages per minute. Para. 0080 discloses that in the alternative, instead of formatting the alert message

based on a particular cellular carrier 380 or 385, the launch server 330 simply sends the unformatted alert message to the SMS server 355/357 of the cellular carrier 380/385 with instructions for the SMS server 355/357 to launch a properly formatted message to all cellular phone currently registered in the SMS server's HLR/VLR database 360." Neither of these citations discloses that the message processing server identify the one or more broadcast message networks from among a plurality of coupled broadcast message networks providing message alerting service to at least a portion of the broadcast target area. For this reason, claim 2 is allowable over *Vella/Allport*.

As to claim 4, claim 4 recites the broadcast service bureau further includes a distributor receiving the broadcast message and broadcast target area and mapping the broadcast target area to determine which one or more of the broadcast message networks from among a plurality of broadcast message networks has a broadcast message distribution system serving at least a portion of the broadcast target area, and wherein the distributor identifies the one or more broadcast message networks. The Office action references Para. 0053 and 0066 of *Vella* for this teaching. Para. 0053 states: after an alert message is generated to include any data input by the alert originator (S120), the alert is delivered to the intended recipients (S130). For example, the alert message is sent to the recipients as a text message, such as an SMS message. The alert message can be sent over the Internet to the various communications service providers servicing the recipients, wherein the recipients receive the alert in a timely and simple manner. Para. 0066 states: prior to delivery of the alert message to the recipients via their cellular phones, the alert message is formatted to comply with the particular address format of each cellular carrier that provides service to one or more of the recipients (S260). The aforementioned OCNs, retrieved from the system database, indicate the identity of the relevant cellular carriers. An address format used by each of these relevant cellular carriers is determined and is used to format the alert message for delivery to those recipients serviced by each of the relevant cellular carriers. For example, if it is determined that a particular three digit exchange belongs to AT&T, those 10,000 alert messages would be formatted as 10DIGITS@mobile.att.net. Another exchange might belong to Verizon, such that an address format of 10DIGITS@vtext.com is used, and another exchange might belong to Cingular, such that a format of 10DIGITS@mobile.mycingular.com is used. The proper address format (e.g., e-mail address) for every cellular entity can be cataloged

and stored, for example in the system database. Neither of these reference discloses the recitation of claim 4 that a distributor receives the broadcast message and broadcast target area and maps the broadcast target area to determine which one or more of the broadcast message networks from among a plurality of broadcast message networks has a broadcast message distribution system serving at least a portion of the broadcast target area, and wherein the distributor identifies the one or more broadcast message networks. Rather *Vella* teaches: a) the alert is delivered to the intended recipient, b) the alert can be sent over the Internet to the recipients and c) formatted as required for delivery to the recipients. In all cases, *Vella* teaches, as fully addressed above, that *Vella* has to know the recipients first. It is a SMS messaging service that requires the identification of the recipient and his address, not whether the serving network maps to or provides service to a portion of the geographic area of the message target area. For these reasons, claim 4 is allowable over *Vella/Allport*.

B. Claims 9-11 stand rejected under 35 U.S.C. § 103(a) as being unpatentable over *Vella* in view of *Allport*, and further in view of U.S. Pub. No. 2004/0203562, issued to *Kolsrud* (hereinafter *Kolsrud*). This rejection is respectfully traversed.

The above review and differentiation of the present claims as to the suggestion combination of *Vella* with *Allport* is herein incorporated by reference and is not repeated. As above, Applicants will first review the teachings of the *Kolsrud* reference and then the suggested combination of *Kolsrud* with *Vella/Allport*. The Office relies on *Kolsrud* for the teaching that it discloses a system for message broadcasting using a carrier broadcast center that converts the broadcast target area to network addresses of wireless transmission devices serving the broadcast target area including determining particular wireless network transmission devices serving at least a portion of the broadcast target area and identifying the network addresses for each and transmitting the broadcast message to each network address. Referring to *Kolsrud*, Paras. 0017, 0020.

Kolsrud

Kolsrud discloses an alerting system that includes an Emergency Broadcast Station 105 that transmits an emergency alert to the base stations 115 of a mobile network for transmitting to mobile telephones 140 served by the receiving base stations 115. *Kolsrud* discloses "The

emergency broadcast station 105 knows which base stations to send signal 150a to because the national, state or local authorities have a database containing all local base stations' geographical locations and cellular coverage areas." *Kolsrud*, Para. 0020. The Applicants note that this statement is false as every mobile carrier closely guards its base station information and in particular the network addressing information for its base stations and the defined serving areas and network elements (transmitters and towers) are dynamic and change all of the time. *See* Applicant's Specification Paras. 0180-0181, 0183, 0186 and 0187 where the Applicant's address the realities of this situation and describe how their system provides a novel and non-obvious solution in view of real world systems, not the mythical system as suggested by *Kolsrud*. *Kolsrud* utilizes this false information and states that the national, state or local authorities' computer database selects the base station(s) to be used for receiving the warning/emergency signal, the emergency broadcast station 105 " *Kolsrud* discloses that the transmit signal is to one or more base stations within or near a projected disaster area (*Kolsrud*, S30); transmitting an alert signal from the base station to the network users (*Kolsrud*, S40); and then having the users tune their handsets to a frequency received in the alert signal to read or receive the emergency broadcast message (*Kolsrud*, S50).

As taught by *Kolsrud*, "The base stations do not transmit the emergency broadcast message itself, but send a signal representing the emergency broadcast message to users served by the base station. The signal contains information that classifies a priority level of the disaster situation, and contains the frequency at which the message is transmitted from an independent AM transmitter at the emergency broadcast station." *Kolsrud*, Para. 0014. The signal is not clearly identified but appears to include transmitting via a "downlink channel" or a paging channel (*Kolsrud*, Para. 0022), or like *Vella*, the system can use an SMS transmission capability of the base station (*Kolsrud*, Para 0027). However, the Applicants note that such an SMS capability at the base station is technically impossible since as described above, SMS messaging requires the identification of the individual telephone numbers of the subscribers.

The signal transmitted by the base station is one that "contains information that classifies a priority level of the disaster situation, and contains the frequency at which the message is transmitted from an independent AM transmitter at the emergency broadcast station. The user, which in one embodiment of the invention is the aforementioned cellular phone, then tunes to the channel in order to receive the information, which can either be voice or data." *Kolsrud*, Para.

0014. *Kolsrud* goes on to describe the modifications to the mobile handsets for enabling the handset to receive AM or FM signals wherein the AM or FM signals will include the broadcast message. *Kolsrud*, Paras. 0015, 0017, 0023. The alert of *Kolsrud* can also include a reference to an 800 number that the user can call to obtain the alert message. *Kolsrud*, Paras. 0019, 0023

Vella/Allport/Kolsrud

From these discussions of *Vella/Allport* and *Kolsrud*, we can now review the suggested modification of *Vella/Allport* by *Kolsrud*. First, contrary to the statements in the Office action, *Vella/Allport/Kolsrud* does not teach or disclose a system or method that can compare or convert a broadcast target area into network addresses for base stations. As addressed above, *Kolsrud* merely discloses, albeit erroneously, that "The emergency broadcast station 105 knows which base stations to send signal 150a to because the national, state or local authorities have a database containing all local base stations' geographical locations and cellular coverage areas." *Kolsrud*, Para. 0020. Contrary to the contention in the Office action, this does not teach or disclose a carrier broadcast server that converts the broadcast target area to network addresses of network transmission devices. *Kolsrud* never mentions or describes any conversion, or network address or the transmitting of a broadcast message to such address.

Secondly, while *Kolsrud* off-handedly mentions SMS text messaging service as a method of transmitting the alert received by the base station, such a capability is technically inaccurate or at would require considerable changes to the existing mobile networks in order to accomplish. As described by *Vella*, text messages do not originate at the base stations, but are received by the mobile carrier either with an existing telephone number or as obtained by querying the HLR/VLR databases. (The Applicants ignore the teaching or combination with *Allport* here as its wireline technology is completely different as discussed above.) As such, even assuming that "knowing" the base stations for a particular target market area is taught by *Kolsrud*, which it is not, *Vella* cannot be modified by *Kolsrud* as *Vella's* and *Allport's* systems require, an initial lookup of the recipients and their phone numbers either via a home database, or via an HLR/VLR and then processes all of the alerts, not the messages, by sending SMS messages to each and every telephone number of the identified recipients. This would be a significant change to the SMS messaging telephone number lookup system which is the fundamental basis of the entire *Vella* and *Allport* disclosures.

Further, *Kolsrud* discloses sending an alert signal that requires the receiving party to tune to another channel, or the handset to tune to an AM or FM channel for actually receiving the message. This is completely contrary to the teachings of *Vella* (as well as *Allport's* device based alerting system based on alert coded signal) and again would require a significant change to the operation of each of the *Vella* and *Allport* systems as well as their combination, without providing any advantages to *Vella*, or *Vella/Allport* as *Vella* actually transmits the actual broadcast message on a point to point basis to each telephone number (*Vella*) or transmits an alerting signal or code to each telephone line (*Allport*) and does not require that the recipients to which the message is transmitted based on their determined telephone numbers to tune to an AM or FM channel to obtain the actual broadcast message as taught by *Vella*, or simply provide a code that initiates an alarm based on a code as taught by *Allport*.

For each and all of these reasons, *Vella* cannot be combined or modified by *Kolsrud* as suggested by the Office action as *Kolsrud* is a completely different technology that cannot be combined, or if one could combine them, would require a substantial reconstruction and redesign of the operations and elements and the basic principles as disclosed by the primary reference *Vella*. See MPEP 2143.01.VI. Additionally, as these reference utilize a completely different technology, one of ordinary skill in the art could not have and would not attempt to combine them as suggested by the Office action. See MPEP 2141.01.V(A). The Office actions stated reasons or motivations to combine these two references, while theoretical ideal in nature, fall short as the teachings of *Kolsrud* cannot improve *Vella's* teachings for more efficient distribution of messages without a significant change to the fundamental teaching of *Vella*, and gutting most, if not all of the message processing functionality as taught by *Vella*. As noted, *Allport's* disclosure is ignored herein as its technology is not related in this regard.

For these reasons alone, all of the rejections to claims 9-11 based on a modification of *Vella/Allport* by *Kolsrud* should be withdrawn as their combination does not support a prima facie obvious rejection.

C. Claims 13 and 14 stand rejected under 35 U.S.C. § 103(a) as being unpatentable over *Vella* in view of *Allport*, and further in view of U.S. Pub. No. 2004/0192258, issued to *Atkin* (hereinafter *Atkin*). This rejection is respectfully traversed.

The above review and differentiation of the present claims as to the suggestion combination of *Vella* with *Allport* is herein incorporated by reference and is not repeated. As above, Applicants will first review the teachings of the *Atkin* reference and then the suggested combination of *Atkin* with *Vella/Allport*.

Atkin is relied upon in the Office action for the teaching that it supposedly discloses a broadcast message in a broadcast request that is a first broadcast message in a first language, and a second broadcast message in a second language. The Office action mistakenly interprets *Atkin* that the server in *Atkin* transmits a broadcast request including the first and second language messages. While the Applicants have amended claims 13 and 14, *Atkins* does not teach or disclose that which the Office relies.

Atkin

Atkins discloses a system for a wireless network that utilizes the mobile device registration process in a VLR (e.g., the traveling device will not be a home device and therefore the HLR does not come into play for the automated translation of messages in *Atkin*). The *Atkin* system retrieves the mobile device registration with the local transmission cellular tower via the BSC and transmits the telephone number which is unique to the assigned home location for the person, unless the traveling party uses an in country mobile device, in which the system of *Akin* will not work. The *Atkin* system presumes the traveler uses their home device and that the visiting cellular network registers the phone, uses the home mobile number or the EIN device number for the mobile device, and maps such against a table to determine a default language for the user. Based on this default home language, which may or may not be the actual language spoken by the person using the device, the messaging system looks to see if there are any alert warnings in the geographic area in which the mobile device just registered or is registered. If there is an alert for such geographic location of the mobile device, before the message is transmitted, the system checks the language for the registered telephone number, and then sends the broadcast message to the devices telephone number using the language identified therewith.

Atkin discloses that the alert messaging system determines or guesses at the language for a message based on the registration number or registration of the mobile device with the network and its current location in the network. The messaging and cellular network determine what language it believes the mobile device user is expecting to receive and then sends any SMS

messages it has to that mobile device in that language or translates it and then send it. It is a point to point message translation system.

Vella/Allport/Atkin

Atkin teaches a user device instigated or identified language registration system for SMS point to point messaging. This is a possible enhancement to *Vella* in that each use a HLR and VLR and sends messages out on a point to point (not broadcast) basis to a set of determined mobile devices that are determined to be within the geographic area of an alert message. For instance, it would appear possible to combine *Atkin* in Fig. 2A of *Vella*, between processes 220 and 240, or as part of process 230, e.g., use the determined phone number, then apply *Atkin* to determine the language for the inputting of the data for the alert in 240, then generate the message in 240 in the determined language for that particular mobile handset.

However, contrary to this potential combination, this is not what claims 13 and 14 recite. Claim 13 recites that the broadcast request that is received by the service bureau that includes the broadcast message to be sent and the target area from the broadcast agent includes a broadcast message that is an alerting system administrative message, and not an actual alert message for which the mobile device owner is to react. Rather, the broadcast request received from the broadcast agent originating the request to send the broadcast message, includes in the broadcast request, a message recall to recall a prior initialed message, an identifier for identifying the language in which the originator of the message wants the message sent, a selection of a particular network from among a plurality of broadcast networks, or a request for the progress status of a prior sent message. None of these are disclosed by *Vella*, *Allport*, or *Atkin*, alone or in combination. The Office relies on *Atkin* apparently as to the language, but as addressed above, *Atkin* teaches that the message is stored and the messaging system determines the language of the message to be sent to the mobile device based on the registration of the device with the VLR. This is completely different than recited by claim 13 wherein the agent that sends the broadcast message request tells the service bureau which language the message is to be sent. It is then pushed through the network, and broadcast based on the agents designated language. As such, claim 13 as to language is clearly not taught by *Atkin*. The other recited features are not

disclosed by any of the cited references. As such, claim 13 is allowable over the combination of *Vella/Allport/Atkin*.

Claim 14 has been amended to clarify its recitations. Claim 14 as amended recites that the broadcast request, as received from the broadcast agent includes is a first and second broadcast message, the first broadcast message being in a first language, and the second broadcast message in a second language. The broadcast service bureau associate the first broadcast message with a first broadcast message channel identifier and the second broadcast message with a second broadcast message channel identifier that is different than the first broadcast message channel identifier. The service bureau then transmits the first broadcast message in the first language with the first broadcast channel identifier and the second broadcast message in the second language with the second broadcast channel identifier. As noted above, claim 14 recites a system wherein the broadcast agent designates the languages and messages in the languages to be broadcast. The service bureau associates or determines a broadcast channel code for each language and each broadcast message is transmitted with the language channel code so that downstream systems will transmit the language in a channel code associated with the language. See specification, Paras. 0062, 0089, 0093-0095, 0106 (assignment of pre-assigned codes for each language), 0113, 0171, and Appendix 1, Para. 211, channel code assignments based on language channels 501-650).

This is completely different than taught by *Atkin* and is not taught or disclosed by the combination of *Vella* with *Atkin* (point to point SMS messaging based on language association with the registration of the particular mobile device).

For these reasons, claim 14 is allowable over the combination of *Vella/Allport/Atkin*.

Claims 18 and 20 stand rejected under 35 U.S.C. § 103(a) as being unpatentable over *Vella* in view of *Allport*, and further in view of U.S. Pub. No. 2005/0013417, issued to *Zimmers* (hereinafter *Zimmers*). This rejection is respectfully traversed.

The above review and differentiation of the present claims as to the suggestion combination of *Vella* with *Allport* is herein incorporated by reference and is not repeated. As above, Applicants will first review the teachings of the *Zimmers* reference and then the suggested combination of *Zimmers* with *Vella/Allport*.

The Office relies on *Zimmers* for the disclosure that Zimmer selects one or more broadcast message networks based on the type of the message and the target area. Referring to *Zimmers*, Para. 0087, 0090-0091.

Zimmers

Zimmers discloses a notification system that includes a plurality of different types of messages, all of which related to IP internet based technology and apparently the PSTN which is the wireline switched network of *Allport*.

As noted in Para. 0091, station identifiers are generated for which alert notifications are directed. Each selected station is evaluated to determine if the station identified is an email address, TCP/IP address or internet accessible pager. When this is done, a data packet is formed to conform with the format of such station identifier and is then sent to a web server for delivery via the internet in the correct format for the intended recipient.

As with *Vella*, *Zimmers* teaches a point to point system wherein the recipient and the recipients IP address must be known. The only difference with *Zimmers* is that it is internet technology that requires protocol formatting based on the knowledge of the station identifier format requirements. The reference in the Office action as to them message type is mistaken and taken out of context, probably due to simplistic key word searching. Para. 0087 of *Zimmers* as relied on in the Office action states that “the notification type is then evaluated . . . to determine if it is a type allowed by the server for the user. If so. . . . additional web based forms are used to prompt the user for relevant information for the notification, such as the geographic information, heading and speed information . . . a data packet is generated (using the format of Table I) reflecting the indicated notification type . . .” *Zimmers*, Para. 0087.

Vella/Allport/Zimmers

As noted, *Zimmers* is an IP internet based notification system. It is not adaptable for use with the SMS text messaging systems of *Vella*. If it were, *Zimmers* merely discloses that the message type that is received is verified “if it is a type allowed by the server for the user.” There is no disclosure or teaching in *Zimmers* or *Vella* or *Allport*, that the broadcast message transmission network is selected based on the message type. Additionally, there is no teaching in *Zimmers* that the broadcast message network is selected based on the broadcast target area. In

Zimmers, the location of the device in the IP network is determined based on user data such as credit card billing address, service subscription address, or is simply sent to the IP address or email address regardless of the location. *Id.* at Para. 0091. Zimmer does not provide any teaching as to a mobile device that happens to be located within the geographic area of the notification and is mobile and changes positions that could be in or out of the geographic area over time. Zimmer does not disclose selecting a different broadcast message network based on the geographic area or based on the message type, but only reformatting the message to meet the format requirements of the station identifiers.

For these reasons, claims 18 and 20 are allowable in view of *Zimmers*, in combination with *Vella* and *Allport*.

CONCLUSION

It is believed that all of the stated grounds of rejection have been properly traversed, accommodated, or rendered moot. Applicants therefore respectfully request that the Examiner reconsider and withdraw all presently outstanding rejections. It is believed that a full and complete response has been made to the outstanding Office Action, and as such, the present application is in condition for allowance. Thus, prompt and favorable consideration of this amendment is respectfully requested. If the Examiner believes that personal communication will expedite prosecution of this application, the Examiner is invited to telephone the undersigned.

Applicant hereby requests a three-month extension to respond to the Office action, and has charged against the Deposit Account to cover the fee for that extension simultaneous with filing of this Amendment. Other than associated with the Terminal Disclaimers, Applicants believe that they do not owe any additional fee in connection with this filing. If, however, Applicants do owe any such fee, the Commissioner is hereby authorized to charge the fee to Deposit Account No. 162201. In addition, if there is ever any other fee deficiency or overpayment under 37 C.F.R. §1.16 or 1.17 in connection with this patent application, the Commissioner is hereby authorized to charge such deficiency or overpayment to Deposit Account No. 162201.

Respectfully submitted,

Dated: October 24, 2012

s/David L. Howard/

DAVID L. HOWARD
Reg. No. 41,502
POLSTER LIEDER WOODRUFF & LUCCHESI
Suite 200
12412 Powerscourt Drive
St. Louis, MO 63131
Tel: 314-238-2460
Fax: 314-238-2401

**TERMINAL DISCLAIMER TO OBIATE A DOUBLE PATENTING
REJECTION OVER A "PRIOR" PATENT**

Docket Number (Optional)

ENIT 9834C2

In re Application of: Mark Wood, Kevin Russell Preston, Douglas Weiser

Application No.: 13/311,448

Filed: December 5, 2011

For: Broadcast Alerting Message Aggregator/Gateway System and Method

The owner*, Edvisioal LLC, of 100 percent interest in the instant application hereby disclaims, except as provided below, the terminal part of the statutory term of any patent granted on the instant application which would extend beyond the expiration date of the full statutory term of prior patent No. 7,752,259 as the term of said prior patent is presently shortened by any terminal disclaimer. The owner hereby agrees that any patent so granted on the instant application shall be enforceable only for and during such period that it and the prior patent are commonly owned. This agreement runs with any patent granted on the instant application and is binding upon the grantee, its successors or assigns.

In making the above disclaimer, the owner does not disclaim the terminal part of the term of any patent granted on the instant application that would extend to the expiration date of the full statutory term of the prior patent, "as the term of said prior patent is presently shortened by any terminal disclaimer," in the event that said prior patent later:

expires for failure to pay a maintenance fee;

is held unenforceable;

is found invalid by a court of competent jurisdiction;

is statutorily disclaimed in whole or terminally disclaimed under 37 CFR 1.321;

has all claims canceled by a reexamination certificate;

is reissued; or

is in any manner terminated prior to the expiration of its full statutory term as presently shortened by any terminal disclaimer.

Check either box 1 or 2 below, if appropriate.

1. For submissions on behalf of a business/organization (e.g., corporation, partnership, university, government agency, etc.), the undersigned is empowered to act on behalf of the business/organization.

I hereby declare that all statements made herein of my own knowledge are true and that all statements made on information and belief are believed to be true; and further that these statements were made with the knowledge that willful false statements and the like so made are punishable by fine or imprisonment, or both, under Section 1001 of Title 18 of the United States Code and that such willful false statements may jeopardize the validity of the application or any patent issued thereon.

2. The undersigned is an attorney or agent of record. Reg. No. 41,502

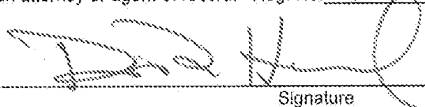
Signature

10/24/12

Date

David L. Howard

Typed or printed name

314-238-2400

Telephone Number

- Terminal disclaimer fee under 37 CFR 1.20(d) included.

WARNING: Information on this form may become public. Credit card information should not be included on this form. Provide credit card information and authorization on PTO-2038.

*Statement under 37 CFR 3.73(b) is required if terminal disclaimer is signed by the assignee (owner).
Form PTO/SB/96 may be used for making this certification. See MPEP § 324.

This collection of information is required by 37 CFR 1.321. The information is required to obtain or retain a benefit by the public which is to file (and by the USPTO to process) an application. Confidentiality is governed by 35 U.S.C. 122 and 37 CFR 1.11 and 1.14. This collection is estimated to take 12 minutes to complete, including gathering, preparing, and submitting the completed application form to the USPTO. Time will vary depending upon the individual case. Any comments on the amount of time you require to complete this form and/or suggestions for reducing this burden, should be sent to the Chief Information Officer, U.S. Patent and Trademark Office, U.S. Department of Commerce, P.O. Box 1450, Alexandria, VA 22313-1450. DO NOT SEND FEES OR COMPLETED FORMS TO THIS ADDRESS. SEND TO: Commissioner for Patents, P.O. Box 1450, Alexandria, VA 22313-1450.

If you need assistance in completing the form, call 1-800-PTO-8199 and select option 2.

Privacy Act Statement

The **Privacy Act of 1974 (P.L. 93-579)** requires that you be given certain information in connection with your submission of the attached form related to a patent application or patent. Accordingly, pursuant to the requirements of the Act, please be advised that: (1) the general authority for the collection of this information is 35 U.S.C. 2(b)(2); (2) furnishing of the information solicited is voluntary; and (3) the principal purpose for which the information is used by the U.S. Patent and Trademark Office is to process and/or examine your submission related to a patent application or patent. If you do not furnish the requested information, the U.S. Patent and Trademark Office may not be able to process and/or examine your submission, which may result in termination of proceedings or abandonment of the application or expiration of the patent.

The information provided by you in this form will be subject to the following routine uses:

1. The information on this form will be treated confidentially to the extent allowed under the Freedom of Information Act (5 U.S.C. 552) and the Privacy Act (5 U.S.C. 552a). Records from this system of records may be disclosed to the Department of Justice to determine whether disclosure of these records is required by the Freedom of Information Act.
2. A record from this system of records may be disclosed, as a routine use, in the course of presenting evidence to a court, magistrate, or administrative tribunal, including disclosures to opposing counsel in the course of settlement negotiations.
3. A record in this system of records may be disclosed, as a routine use, to a Member of Congress submitting a request involving an individual, to whom the record pertains, when the individual has requested assistance from the Member with respect to the subject matter of the record.
4. A record in this system of records may be disclosed, as a routine use, to a contractor of the Agency having need for the information in order to perform a contract. Recipients of information shall be required to comply with the requirements of the Privacy Act of 1974, as amended, pursuant to 5 U.S.C. 552a(m).
5. A record related to an International Application filed under the Patent Cooperation Treaty in this system of records may be disclosed, as a routine use, to the International Bureau of the World Intellectual Property Organization, pursuant to the Patent Cooperation Treaty.
6. A record in this system of records may be disclosed, as a routine use, to another federal agency for purposes of National Security review (35 U.S.C. 181) and for review pursuant to the Atomic Energy Act (42 U.S.C. 218(c)).
7. A record from this system of records may be disclosed, as a routine use, to the Administrator, General Services, or his/her designee, during an inspection of records conducted by GSA as part of that agency's responsibility to recommend improvements in records management practices and programs, under authority of 44 U.S.C. 2904 and 2906. Such disclosure shall be made in accordance with the GSA regulations governing inspection of records for this purpose, and any other relevant (*i.e.*, GSA or Commerce) directive. Such disclosure shall not be used to make determinations about individuals.
8. A record from this system of records may be disclosed, as a routine use, to the public after either publication of the application pursuant to 35 U.S.C. 122(b) or issuance of a patent pursuant to 35 U.S.C. 151. Further, a record may be disclosed, subject to the limitations of 37 CFR 1.14, as a routine use, to the public if the record was filed in an application which became abandoned or in which the proceedings were terminated and which application is referenced by either a published application, an application open to public inspection or an issued patent.
9. A record from this system of records may be disclosed, as a routine use, to a Federal, State, or local law enforcement agency, if the USPTO becomes aware of a violation or potential violation of law or regulation.

**TERMINAL DISCLAIMER TO OBVIATE A DOUBLE PATENTING
REJECTION OVER A "PRIOR" PATENT**Docket Number (Optional)
ENIT 9834C2

In re Application of: Mark Wood, Kevin Russell Preston, Douglas Weiser

Application No.: 13/311,448

Filed: December 5, 2011

For: Broadcast Alerting Message Aggregator/Gateway System and Method

The owner, EnvisionIT, LLC, of 100 percent interest in the instant application hereby disclaims, except as provided below, the terminal part of the statutory term of any patent granted on the instant application which would extend beyond the expiration date of the full statutory term of prior patent No. 8,073,903 as the term of said prior patent is presently shortened by any terminal disclaimer. The owner hereby agrees that any patent so granted on the instant application shall be enforceable only for and during such period that it and the prior patent are commonly owned. This agreement runs with any patent granted on the instant application and is binding upon the grantee, its successors or assigns.

In making the above disclaimer, the owner does not disclaim the terminal part of the term of any patent granted on the instant application that would extend to the expiration date of the full statutory term of the prior patent, "as the term of said prior patent is presently shortened by any terminal disclaimer," in the event that said prior patent later:

- expires for failure to pay a maintenance fee;
- is held unenforceable;
- is found invalid by a court of competent jurisdiction;
- is statutorily disclaimed in whole or terminally disclaimed under 37 CFR 1.321;
- has all claims canceled by a reexamination certificate;
- is reissued; or
- is in any manner terminated prior to the expiration of its full statutory term as presently shortened by any terminal disclaimer.

Check either box 1 or 2 below, if appropriate.

1. For submissions on behalf of a business/organization (e.g., corporation, partnership, university, government agency, etc.), the undersigned is empowered to act on behalf of the business/organization.

I hereby declare that all statements made herein of my own knowledge are true and that all statements made on information and belief are believed to be true; and further that these statements were made with the knowledge that willful false statements and the like so made are punishable by fine or imprisonment, or both, under Section 1001 of Title 18 of the United States Code and that such willful false statements may jeopardize the validity of the application or any patent issued thereon.

2. The undersigned is an attorney or agent of record. Reg. No. 41,502

Signature

10/24/12
Date

David L. Howard
Typed or printed name

314-238-2400
Telephone Number

- Terminal disclaimer fee under 37 CFR 1.20(d) included.

WARNING: Information on this form may become public. Credit card information should not be included on this form. Provide credit card information and authorization on PTO-2038.

*Statement under 37 CFR 3.73(b) is required if terminal disclaimer is signed by the assignee (owner).
Form PTO/SB/96 may be used for making this certification. See MPEP § 324.

This collection of information is required by 37 CFR 1.321. The information is required to obtain or retain a benefit by the public which is to file (and by the USPTO to process) an application. Confidentiality is governed by 35 U.S.C. 122 and 37 CFR 1.11 and 1.14. This collection is estimated to take 12 minutes to complete, including gathering, preparing, and submitting the completed application form to the USPTO. Time will vary depending upon the individual case. Any comments on the amount of time you require to complete this form and/or suggestions for reducing this burden, should be sent to the Chief Information Officer, U.S. Patent and Trademark Office, U.S. Department of Commerce, P.O. Box 1450, Alexandria, VA 22313-1450. DO NOT SEND FEES OR COMPLETED FORMS TO THIS ADDRESS. SEND TO: Commissioner for Patents, P.O. Box 1450, Alexandria, VA 22313-1450.

If you need assistance in completing the form, call 1-800-PTO-9199 and select option 2.

Privacy Act Statement

The **Privacy Act of 1974 (P.L. 93-579)** requires that you be given certain information in connection with your submission of the attached form related to a patent application or patent. Accordingly, pursuant to the requirements of the Act, please be advised that: (1) the general authority for the collection of this information is 35 U.S.C. 2(b)(2); (2) furnishing of the information solicited is voluntary; and (3) the principal purpose for which the information is used by the U.S. Patent and Trademark Office is to process and/or examine your submission related to a patent application or patent. If you do not furnish the requested information, the U.S. Patent and Trademark Office may not be able to process and/or examine your submission, which may result in termination of proceedings or abandonment of the application or expiration of the patent.

The information provided by you in this form will be subject to the following routine uses:

1. The information on this form will be treated confidentially to the extent allowed under the Freedom of Information Act (5 U.S.C. 552) and the Privacy Act (5 U.S.C. 552a). Records from this system of records may be disclosed to the Department of Justice to determine whether disclosure of these records is required by the Freedom of Information Act.
2. A record from this system of records may be disclosed, as a routine use, in the course of presenting evidence to a court, magistrate, or administrative tribunal, including disclosures to opposing counsel in the course of settlement negotiations.
3. A record in this system of records may be disclosed, as a routine use, to a Member of Congress submitting a request involving an individual, to whom the record pertains, when the individual has requested assistance from the Member with respect to the subject matter of the record.
4. A record in this system of records may be disclosed, as a routine use, to a contractor of the Agency having need for the information in order to perform a contract. Recipients of information shall be required to comply with the requirements of the Privacy Act of 1974, as amended, pursuant to 5 U.S.C. 552a(m).
5. A record related to an International Application filed under the Patent Cooperation Treaty in this system of records may be disclosed, as a routine use, to the International Bureau of the World Intellectual Property Organization, pursuant to the Patent Cooperation Treaty.
6. A record in this system of records may be disclosed, as a routine use, to another federal agency for purposes of National Security review (35 U.S.C. 181) and for review pursuant to the Atomic Energy Act (42 U.S.C. 218(c)).
7. A record from this system of records may be disclosed, as a routine use, to the Administrator, General Services, or his/her designee, during an inspection of records conducted by GSA as part of that agency's responsibility to recommend improvements in records management practices and programs, under authority of 44 U.S.C. 2904 and 2906. Such disclosure shall be made in accordance with the GSA regulations governing inspection of records for this purpose, and any other relevant (*i.e.*, GSA or Commerce) directive. Such disclosure shall not be used to make determinations about individuals.
8. A record from this system of records may be disclosed, as a routine use, to the public after either publication of the application pursuant to 35 U.S.C. 122(b) or issuance of a patent pursuant to 35 U.S.C. 151. Further, a record may be disclosed, subject to the limitations of 37 CFR 1.14, as a routine use, to the public if the record was filed in an application which became abandoned or in which the proceedings were terminated and which application is referenced by either a published application, an application open to public inspection or an issued patent.
9. A record from this system of records may be disclosed, as a routine use, to a Federal, State, or local law enforcement agency, if the USPTO becomes aware of a violation or potential violation of law or regulation.

Electronic Patent Application Fee Transmittal

Application Number:	13311448			
Filing Date:	05-Dec-2011			
Title of Invention:	BROADCAST ALERTING MESSAGE AGGREGATOR/GATEWAY SYSTEM AND METHOD			
First Named Inventor/Applicant Name:	Mark Andrew Wood			
Filer:	David L. Howard/Kim Adler			
Attorney Docket Number:	ENIT 9834C2			
Filed as Small Entity				
Utility under 35 USC 111(a) Filing Fees				
Description	Fee Code	Quantity	Amount	Sub-Total in USD(\$)
Basic Filing:				
Pages:				
Claims:				
Miscellaneous-Filing:				
Petition:				
Patent-Appeals-and-Interference:				
Post-Allowance-and-Post-Issuance:				
Statutory or terminal disclaimer	2814	2	80	160
Extension-of-Time:				

Description	Fee Code	Quantity	Amount	Sub-Total in USD(\$)
Extension - 3 months with \$0 paid	2253	1	645	645
Miscellaneous:				
Total in USD (\$)				805

Electronic Acknowledgement Receipt

EFS ID:	14064656
Application Number:	13311448
International Application Number:	
Confirmation Number:	9039
Title of Invention:	BROADCAST ALERTING MESSAGE AGGREGATOR/GATEWAY SYSTEM AND METHOD
First Named Inventor/Applicant Name:	Mark Andrew Wood
Customer Number:	1688
Filer:	David L. Howard
Filer Authorized By:	
Attorney Docket Number:	ENIT 9834C2
Receipt Date:	24-OCT-2012
Filing Date:	05-DEC-2011
Time Stamp:	16:02:17
Application Type:	Utility under 35 USC 111(a)

Payment information:

Submitted with Payment	yes
Payment Type	Deposit Account
Payment was successfully received in RAM	\$805
RAM confirmation Number	2938
Deposit Account	162201
Authorized User	

File Listing:

Document Number	Document Description	File Name	File Size(Bytes)/ Message Digest	Multi Part /.zip	Pages (if appl.)
-----------------	----------------------	-----------	-------------------------------------	------------------	------------------

1		ENIT_9834C2_Am_A_RTOA_4-24-12.pdf	139668 45e4244fb7bdd234416a590bc13ccc8f43bf66e	yes	26
Multipart Description/PDF files in .zip description					
		Document Description	Start	End	
		Amendment/Req. Reconsideration-After Non-Final Reject	1	1	
		Claims	2	6	
		Applicant Arguments/Remarks Made in an Amendment	7	26	
Warnings:					
Information:					
2	Terminal Disclaimer Filed	ENIT_9834C2_Terminal_Disclaimer_7752259.pdf	695730 0d3889aaabcb92854b61c4d09b83603332655c80	no	2
Warnings:					
The page size in the PDF is too large. The pages should be 8.5 x 11 or A4. If this PDF is submitted, the pages will be resized upon entry into the Image File Wrapper and may affect subsequent processing					
Information:					
3	Terminal Disclaimer Filed	ENIT_9834C2_Terminal_Disclaimer_8073903.pdf	693457 ea2190c786b6e576df3ac3eea33d4ab5c5b4d4c1	no	2
Warnings:					
The page size in the PDF is too large. The pages should be 8.5 x 11 or A4. If this PDF is submitted, the pages will be resized upon entry into the Image File Wrapper and may affect subsequent processing					
Information:					
4	Fee Worksheet (SB06)	fee-info.pdf	32343 c7c0abca767586d16fcc497e3d10619e1a8dde79	no	2
Warnings:					
Information:					
Total Files Size (in bytes):			1561198		

This Acknowledgement Receipt evidences receipt on the noted date by the USPTO of the indicated documents, characterized by the applicant, and including page counts, where applicable. It serves as evidence of receipt similar to a Post Card, as described in MPEP 503.

New Applications Under 35 U.S.C. 111

If a new application is being filed and the application includes the necessary components for a filing date (see 37 CFR 1.53(b)-(d) and MPEP 506), a Filing Receipt (37 CFR 1.54) will be issued in due course and the date shown on this Acknowledgement Receipt will establish the filing date of the application.

National Stage of an International Application under 35 U.S.C. 371

If a timely submission to enter the national stage of an international application is compliant with the conditions of 35 U.S.C. 371 and other applicable requirements a Form PCT/DO/EO/903 indicating acceptance of the application as a national stage submission under 35 U.S.C. 371 will be issued in addition to the Filing Receipt, in due course.

New International Application Filed with the USPTO as a Receiving Office

If a new international application is being filed and the international application includes the necessary components for an international filing date (see PCT Article 11 and MPEP 1810), a Notification of the International Application Number and of the International Filing Date (Form PCT/RO/105) will be issued in due course, subject to prescriptions concerning national security, and the date shown on this Acknowledgement Receipt will establish the international filing date of the application.

Under the Paperwork Reduction Act of 1995, no persons are required to respond to a collection of information unless it displays a valid OMB control number.

PATENT APPLICATION FEE DETERMINATION RECORD Substitute for Form PTO-875					Application or Docket Number 13/311,448	Filing Date 12/05/2011	<input type="checkbox"/> To be Mailed		
APPLICATION AS FILED – PART I					SMALL ENTITY <input checked="" type="checkbox"/> OR		OTHER THAN SMALL ENTITY		
(Column 1)		(Column 2)							
FOR	NUMBER FILED	NUMBER EXTRA	RATE (\$)	FEE (\$)	OR	RATE (\$)	FEE (\$)		
<input type="checkbox"/> BASIC FEE <small>(37 CFR 1.16(a), (b), or (c))</small>	N/A	N/A	N/A			N/A			
<input type="checkbox"/> SEARCH FEE <small>(37 CFR 1.16(k), (l), or (m))</small>	N/A	N/A	N/A			N/A			
<input type="checkbox"/> EXAMINATION FEE <small>(37 CFR 1.16(o), (p), or (q))</small>	N/A	N/A	N/A			N/A			
TOTAL CLAIMS <small>(37 CFR 1.16(i))</small>	minus 20 =	*	X \$ =		OR	X \$ =			
INDEPENDENT CLAIMS <small>(37 CFR 1.16(h))</small>	minus 3 =	*	X \$ =			X \$ =			
<input type="checkbox"/> APPLICATION SIZE FEE <small>(37 CFR 1.16(s))</small>		If the specification and drawings exceed 100 sheets of paper, the application size fee due is \$250 (\$125 for small entity) for each additional 50 sheets or fraction thereof. See 35 U.S.C. 41(a)(1)(G) and 37 CFR 1.16(s).							
<input type="checkbox"/> MULTIPLE DEPENDENT CLAIM PRESENT <small>(37 CFR 1.16(j))</small>									
					TOTAL	TOTAL			
					* If the difference in column 1 is less than zero, enter "0" in column 2.				
APPLICATION AS AMENDED – PART II					SMALL ENTITY		OTHER THAN SMALL ENTITY		
(Column 1)		(Column 2)		(Column 3)					
AMENDMENT	10/24/2012	CLAIMS REMAINING AFTER AMENDMENT	HIGHEST NUMBER PREVIOUSLY PAID FOR	PRESENT EXTRA	RATE (\$)	ADDITIONAL FEE (\$)	OR	RATE (\$)	ADDITIONAL FEE (\$)
	Total <small>(37 CFR 1.16(i))</small>	* 20	Minus	** 20	= 0	X \$31 =	0	OR	X \$ =
	Independent <small>(37 CFR 1.16(h))</small>	* 2	Minus	***3	= 0	X \$125 =	0	OR	X \$ =
	<input type="checkbox"/> Application Size Fee <small>(37 CFR 1.16(s))</small>								
	<input type="checkbox"/> FIRST PRESENTATION OF MULTIPLE DEPENDENT CLAIM <small>(37 CFR 1.16(j))</small>								
					TOTAL ADD'L FEE	0	OR	TOTAL ADD'L FEE	
(Column 1)		(Column 2)		(Column 3)					
AMENDMENT		CLAIMS REMAINING AFTER AMENDMENT	HIGHEST NUMBER PREVIOUSLY PAID FOR	PRESENT EXTRA	RATE (\$)	ADDITIONAL FEE (\$)	OR	RATE (\$)	ADDITIONAL FEE (\$)
	Total <small>(37 CFR 1.16(i))</small>	*	Minus	**	=	X \$ =		OR	X \$ =
	Independent <small>(37 CFR 1.16(h))</small>	*	Minus	***	=	X \$ =		OR	X \$ =
	<input type="checkbox"/> Application Size Fee <small>(37 CFR 1.16(s))</small>								
	<input type="checkbox"/> FIRST PRESENTATION OF MULTIPLE DEPENDENT CLAIM <small>(37 CFR 1.16(j))</small>								
					TOTAL ADD'L FEE		OR	TOTAL ADD'L FEE	
					* If the entry in column 1 is less than the entry in column 2, write "0" in column 3. ** If the "Highest Number Previously Paid For" IN THIS SPACE is less than 20, enter "20". *** If the "Highest Number Previously Paid For" IN THIS SPACE is less than 3, enter "3". The "Highest Number Previously Paid For" (Total or Independent) is the highest number found in the appropriate box in column 1.				

Legal Instrument Examiner:
/TRACIE HARGROVE/

This collection of information is required by 37 CFR 1.16. The information is required to obtain or retain a benefit by the public which is to file (and by the USPTO to process) an application. Confidentiality is governed by 35 U.S.C. 122 and 37 CFR 1.14. This collection is estimated to take 12 minutes to complete, including gathering, preparing, and submitting the completed application form to the USPTO. Time will vary depending upon the individual case. Any comments on the amount of time you require to complete this form and/or suggestions for reducing this burden, should be sent to the Chief Information Officer, U.S. Patent and Trademark Office, U.S. Department of Commerce, P.O. Box 1450, Alexandria, VA 22313-1450. DO NOT SEND FEES OR COMPLETED FORMS TO THIS ADDRESS. **SEND TO: Commissioner for Patents, P.O. Box 1450, Alexandria, VA 22313-1450.**

If you need assistance in completing the form, call 1-800-PTO-9199 and select option 2.

Application Number 	Application/Control No. 13/311,448	Applicant(s)/Patent under Reexamination WOOD ET AL.	

Document Code - DISQ	Internal Document – DO NOT MAIL
-----------------------------	--

TERMINAL DISCLAIMER	<input checked="" type="checkbox"/> APPROVED	<input type="checkbox"/> DISAPPROVED
Date Filed : Both tds 10-24-2012	This patent is subject to a Terminal Disclaimer	

Approved/Disapproved by:

Dorethea Lawrence



UNITED STATES PATENT AND TRADEMARK OFFICE

UNITED STATES DEPARTMENT OF COMMERCE
United States Patent and Trademark Office
Address: COMMISSIONER FOR PATENTS
P.O. Box 1450
Alexandria, Virginia 22313-1450
www.uspto.gov

NOTICE OF ALLOWANCE AND FEE(S) DUE

1688 7590 12/11/2012
Polster, Lieder, Woodruff & Lucchesi, L.C.
12412 Powerscourt Dr. Suite 200
St. Louis, MO 63131-3615

EXAMINER
JOO, JOSHUA

ART UNIT PAPER NUMBER
2445

DATE MAILED: 12/11/2012

Table with 5 columns: APPLICATION NO., FILING DATE, FIRST NAMED INVENTOR, ATTORNEY DOCKET NO., CONFIRMATION NO.
13/311,448 12/05/2011 Mark Andrew Wood ENIT 9834C2 9039

TITLE OF INVENTION: BROADCAST ALERTING MESSAGE AGGREGATOR/GATEWAY SYSTEM AND METHOD

Table with 7 columns: APPLN. TYPE, SMALL ENTITY, ISSUE FEE DUE, PUBLICATION FEE DUE, PREV. PAID ISSUE FEE, TOTAL FEE(S) DUE, DATE DUE
nonprovisional YES \$885 \$300 \$0 \$1185 03/11/2013

THE APPLICATION IDENTIFIED ABOVE HAS BEEN EXAMINED AND IS ALLOWED FOR ISSUANCE AS A PATENT. PROSECUTION ON THE MERITS IS CLOSED. THIS NOTICE OF ALLOWANCE IS NOT A GRANT OF PATENT RIGHTS. THIS APPLICATION IS SUBJECT TO WITHDRAWAL FROM ISSUE AT THE INITIATIVE OF THE OFFICE OR UPON PETITION BY THE APPLICANT. SEE 37 CFR 1.313 AND MPEP 1308.

THE ISSUE FEE AND PUBLICATION FEE (IF REQUIRED) MUST BE PAID WITHIN THREE MONTHS FROM THE MAILING DATE OF THIS NOTICE OR THIS APPLICATION SHALL BE REGARDED AS ABANDONED. THIS STATUTORY PERIOD CANNOT BE EXTENDED. SEE 35 U.S.C. 151. THE ISSUE FEE DUE INDICATED ABOVE DOES NOT REFLECT A CREDIT FOR ANY PREVIOUSLY PAID ISSUE FEE IN THIS APPLICATION. IF AN ISSUE FEE HAS PREVIOUSLY BEEN PAID IN THIS APPLICATION (AS SHOWN ABOVE), THE RETURN OF PART B OF THIS FORM WILL BE CONSIDERED A REQUEST TO REAPPLY THE PREVIOUSLY PAID ISSUE FEE TOWARD THE ISSUE FEE NOW DUE.

HOW TO REPLY TO THIS NOTICE:

I. Review the SMALL ENTITY status shown above.

If the SMALL ENTITY is shown as YES, verify your current SMALL ENTITY status:

A. If the status is the same, pay the TOTAL FEE(S) DUE shown above.

B. If the status above is to be removed, check box 5b on Part B - Fee(s) Transmittal and pay the PUBLICATION FEE (if required) and twice the amount of the ISSUE FEE shown above, or

If the SMALL ENTITY is shown as NO:

A. Pay TOTAL FEE(S) DUE shown above, or

B. If applicant claimed SMALL ENTITY status before, or is now claiming SMALL ENTITY status, check box 5a on Part B - Fee(s) Transmittal and pay the PUBLICATION FEE (if required) and 1/2 the ISSUE FEE shown above.

II. PART B - FEE(S) TRANSMITTAL, or its equivalent, must be completed and returned to the United States Patent and Trademark Office (USPTO) with your ISSUE FEE and PUBLICATION FEE (if required). If you are charging the fee(s) to your deposit account, section "4b" of Part B - Fee(s) Transmittal should be completed and an extra copy of the form should be submitted. If an equivalent of Part B is filed, a request to reapply a previously paid issue fee must be clearly made, and delays in processing may occur due to the difficulty in recognizing the paper as an equivalent of Part B.

III. All communications regarding this application must give the application number. Please direct all communications prior to issuance to Mail Stop ISSUE FEE unless advised to the contrary.

IMPORTANT REMINDER: Utility patents issuing on applications filed on or after Dec. 12, 1980 may require payment of maintenance fees. It is patentee's responsibility to ensure timely payment of maintenance fees when due.

PART B - FEE(S) TRANSMITTAL

**Complete and send this form, together with applicable fee(s), to: Mail Mail Stop ISSUE FEE
 Commissioner for Patents
 P.O. Box 1450
 Alexandria, Virginia 22313-1450
 or Fax (571)-273-2885**

INSTRUCTIONS: This form should be used for transmitting the ISSUE FEE and PUBLICATION FEE (if required). Blocks 1 through 5 should be completed where appropriate. All further correspondence including the Patent, advance orders and notification of maintenance fees will be mailed to the current correspondence address as indicated unless corrected below or directed otherwise in Block 1, by (a) specifying a new correspondence address; and/or (b) indicating a separate "FEE ADDRESS" for maintenance fee notifications.

CURRENT CORRESPONDENCE ADDRESS (Note: Use Block 1 for any change of address)

1688 7590 12/11/2012
 Polster, Lieder, Woodruff & Lucchesi, L.C.
 12412 Powerscourt Dr. Suite 200
 St. Louis, MO 63131-3615

Note: A certificate of mailing can only be used for domestic mailings of the Fee(s) Transmittal. This certificate cannot be used for any other accompanying papers. Each additional paper, such as an assignment or formal drawing, must have its own certificate of mailing or transmission.

Certificate of Mailing or Transmission

I hereby certify that this Fee(s) Transmittal is being deposited with the United States Postal Service with sufficient postage for first class mail in an envelope addressed to the Mail Stop ISSUE FEE address above, or being facsimile transmitted to the USPTO (571) 273-2885, on the date indicated below.

(Depositor's name)
(Signature)
(Date)

APPLICATION NO.	FILING DATE	FIRST NAMED INVENTOR	ATTORNEY DOCKET NO.	CONFIRMATION NO.
13/311,448	12/05/2011	Mark Andrew Wood	ENIT 9834C2	9039

TITLE OF INVENTION: BROADCAST ALERTING MESSAGE AGGREGATOR/GATEWAY SYSTEM AND METHOD

APPLN. TYPE	SMALL ENTITY	ISSUE FEE DUE	PUBLICATION FEE DUE	PREV. PAID ISSUE FEE	TOTAL FEE(S) DUE	DATE DUE
nonprovisional	YES	\$885	\$300	\$0	\$1185	03/11/2013

EXAMINER	ART UNIT	CLASS-SUBCLASS
JOO, JOSHUA	2445	709-203000

<p>1. Change of correspondence address or indication of "Fee Address" (37 CFR 1.363).</p> <p><input type="checkbox"/> Change of correspondence address (or Change of Correspondence Address form PTO/SB/122) attached.</p> <p><input type="checkbox"/> "Fee Address" indication (or "Fee Address" Indication form PTO/SB/47; Rev 03-02 or more recent) attached. Use of a Customer Number is required.</p>	<p>2. For printing on the patent front page, list</p> <p>(1) the names of up to 3 registered patent attorneys or agents OR, alternatively, _____ 1 _____</p> <p>(2) the name of a single firm (having as a member a registered attorney or agent) and the names of up to 2 registered patent attorneys or agents. If no name is listed, no name will be printed. _____ 2 _____</p> <p>_____ 3 _____</p>
---	---

3. ASSIGNEE NAME AND RESIDENCE DATA TO BE PRINTED ON THE PATENT (print or type)

PLEASE NOTE: Unless an assignee is identified below, no assignee data will appear on the patent. If an assignee is identified below, the document has been filed for recordation as set forth in 37 CFR 3.11. Completion of this form is NOT a substitute for filing an assignment.

(A) NAME OF ASSIGNEE _____ (B) RESIDENCE: (CITY and STATE OR COUNTRY) _____

Please check the appropriate assignee category or categories (will not be printed on the patent) : Individual Corporation or other private group entity Government

<p>4a. The following fee(s) are submitted:</p> <p><input type="checkbox"/> Issue Fee</p> <p><input type="checkbox"/> Publication Fee (No small entity discount permitted)</p> <p><input type="checkbox"/> Advance Order - # of Copies _____</p>	<p>4b. Payment of Fee(s): (Please first reapply any previously paid issue fee shown above)</p> <p><input type="checkbox"/> A check is enclosed.</p> <p><input type="checkbox"/> Payment by credit card. Form PTO-2038 is attached.</p> <p><input type="checkbox"/> The Director is hereby authorized to charge the required fee(s), any deficiency, or credit any overpayment, to Deposit Account Number _____ (enclose an extra copy of this form).</p>
---	---

5. **Change in Entity Status** (from status indicated above)

a. Applicant claims SMALL ENTITY status. See 37 CFR 1.27. b. Applicant is no longer claiming SMALL ENTITY status. See 37 CFR 1.27(g)(2).

NOTE: The Issue Fee and Publication Fee (if required) will not be accepted from anyone other than the applicant; a registered attorney or agent; or the assignee or other party in interest as shown by the records of the United States Patent and Trademark Office.

Authorized Signature _____ Date _____

Typed or printed name _____ Registration No. _____

This collection of information is required by 37 CFR 1.311. The information is required to obtain or retain a benefit by the public which is to file (and by the USPTO to process) an application. Confidentiality is governed by 35 U.S.C. 122 and 37 CFR 1.14. This collection is estimated to take 12 minutes to complete, including gathering, preparing, and submitting the completed application form to the USPTO. Time will vary depending upon the individual case. Any comments on the amount of time you require to complete this form and/or suggestions for reducing this burden, should be sent to the Chief Information Officer, U.S. Patent and Trademark Office, U.S. Department of Commerce, P.O. Box 1450, Alexandria, Virginia 22313-1450. **DO NOT SEND FEES OR COMPLETED FORMS TO THIS ADDRESS. SEND TO: Commissioner for Patents, P.O. Box 1450, Alexandria, Virginia 22313-1450.**

Under the Paperwork Reduction Act of 1995, no persons are required to respond to a collection of information unless it displays a valid OMB control number.



UNITED STATES PATENT AND TRADEMARK OFFICE

UNITED STATES DEPARTMENT OF COMMERCE
United States Patent and Trademark Office
Address: COMMISSIONER FOR PATENTS
P.O. Box 1450
Alexandria, Virginia 22313-1450
www.uspto.gov

Table with 5 columns: APPLICATION NO., FILING DATE, FIRST NAMED INVENTOR, ATTORNEY DOCKET NO., CONFIRMATION NO.
13/311,448 12/05/2011 Mark Andrew Wood ENIT 9834C2 9039
1688 7590 12/11/2012
Polster, Lieder, Woodruff & Lucchesi, L.C.
12412 Powerscourt Dr. Suite 200
St. Louis, MO 63131-3615
EXAMINER
JOO, JOSHUA
ART UNIT PAPER NUMBER
2445

DATE MAILED: 12/11/2012

Determination of Patent Term Adjustment under 35 U.S.C. 154 (b)
(application filed on or after May 29, 2000)

The Patent Term Adjustment to date is 0 day(s). If the issue fee is paid on the date that is three months after the mailing date of this notice and the patent issues on the Tuesday before the date that is 28 weeks (six and a half months) after the mailing date of this notice, the Patent Term Adjustment will be 0 day(s).

If a Continued Prosecution Application (CPA) was filed in the above-identified application, the filing date that determines Patent Term Adjustment is the filing date of the most recent CPA.

Applicant will be able to obtain more detailed information by accessing the Patent Application Information Retrieval (PAIR) WEB site (http://pair.uspto.gov).

Any questions regarding the Patent Term Extension or Adjustment determination should be directed to the Office of Patent Legal Administration at (571)-272-7702. Questions relating to issue and publication fee payments should be directed to the Customer Service Center of the Office of Patent Publication at 1-(888)-786-0101 or (571)-272-4200.

Privacy Act Statement

The Privacy Act of 1974 (P.L. 93-579) requires that you be given certain information in connection with your submission of the attached form related to a patent application or patent. Accordingly, pursuant to the requirements of the Act, please be advised that: (1) the general authority for the collection of this information is 35 U.S.C. 2(b)(2); (2) furnishing of the information solicited is voluntary; and (3) the principal purpose for which the information is used by the U.S. Patent and Trademark Office is to process and/or examine your submission related to a patent application or patent. If you do not furnish the requested information, the U.S. Patent and Trademark Office may not be able to process and/or examine your submission, which may result in termination of proceedings or abandonment of the application or expiration of the patent.

The information provided by you in this form will be subject to the following routine uses:

1. The information on this form will be treated confidentially to the extent allowed under the Freedom of Information Act (5 U.S.C. 552) and the Privacy Act (5 U.S.C. 552a). Records from this system of records may be disclosed to the Department of Justice to determine whether disclosure of these records is required by the Freedom of Information Act.
2. A record from this system of records may be disclosed, as a routine use, in the course of presenting evidence to a court, magistrate, or administrative tribunal, including disclosures to opposing counsel in the course of settlement negotiations.
3. A record in this system of records may be disclosed, as a routine use, to a Member of Congress submitting a request involving an individual, to whom the record pertains, when the individual has requested assistance from the Member with respect to the subject matter of the record.
4. A record in this system of records may be disclosed, as a routine use, to a contractor of the Agency having need for the information in order to perform a contract. Recipients of information shall be required to comply with the requirements of the Privacy Act of 1974, as amended, pursuant to 5 U.S.C. 552a(m).
5. A record related to an International Application filed under the Patent Cooperation Treaty in this system of records may be disclosed, as a routine use, to the International Bureau of the World Intellectual Property Organization, pursuant to the Patent Cooperation Treaty.
6. A record in this system of records may be disclosed, as a routine use, to another federal agency for purposes of National Security review (35 U.S.C. 181) and for review pursuant to the Atomic Energy Act (42 U.S.C. 218(c)).
7. A record from this system of records may be disclosed, as a routine use, to the Administrator, General Services, or his/her designee, during an inspection of records conducted by GSA as part of that agency's responsibility to recommend improvements in records management practices and programs, under authority of 44 U.S.C. 2904 and 2906. Such disclosure shall be made in accordance with the GSA regulations governing inspection of records for this purpose, and any other relevant (i.e., GSA or Commerce) directive. Such disclosure shall not be used to make determinations about individuals.
8. A record from this system of records may be disclosed, as a routine use, to the public after either publication of the application pursuant to 35 U.S.C. 122(b) or issuance of a patent pursuant to 35 U.S.C. 151. Further, a record may be disclosed, subject to the limitations of 37 CFR 1.14, as a routine use, to the public if the record was filed in an application which became abandoned or in which the proceedings were terminated and which application is referenced by either a published application, an application open to public inspection or an issued patent.
9. A record from this system of records may be disclosed, as a routine use, to a Federal, State, or local law enforcement agency, if the USPTO becomes aware of a violation or potential violation of law or regulation.

Notice of Allowability	Application No.	Applicant(s)	
	13/311,448	WOOD ET AL.	
	Examiner	Art Unit	
	JOSHUA JOO	2445	

-- The MAILING DATE of this communication appears on the cover sheet with the correspondence address--

All claims being allowable, PROSECUTION ON THE MERITS IS (OR REMAINS) CLOSED in this application. If not included herewith (or previously mailed), a Notice of Allowance (PTOL-85) or other appropriate communication will be mailed in due course. **THIS NOTICE OF ALLOWABILITY IS NOT A GRANT OF PATENT RIGHTS.** This application is subject to withdrawal from issue at the initiative of the Office or upon petition by the applicant. See 37 CFR 1.313 and MPEP 1308.

1. This communication is responsive to Applicant's response filed on October 24, 2012.
2. An election was made by the applicant in response to a restriction requirement set forth during the interview on ____; the restriction requirement and election have been incorporated into this action.
3. The allowed claim(s) is/are 1-20. As a result of the allowed claim(s), you may be eligible to benefit from the **Patent Prosecution Highway** program at a participating intellectual property office for the corresponding application. For more information, please see http://www.uspto.gov/patents/init_events/pph/index.jsp or send an inquiry to PPHfeedback@uspto.gov.
4. Acknowledgment is made of a claim for foreign priority under 35 U.S.C. § 119(a)-(d) or (f).
 - a) All b) Some* c) None of the:
 1. Certified copies of the priority documents have been received.
 2. Certified copies of the priority documents have been received in Application No. ____ .
 3. Copies of the certified copies of the priority documents have been received in this national stage application from the International Bureau (PCT Rule 17.2(a)).

* Certified copies not received: ____.

Applicant has **THREE MONTHS FROM THE "MAILING DATE"** of this communication to file a reply complying with the requirements noted below. Failure to timely comply will result in **ABANDONMENT** of this application.
THIS THREE-MONTH PERIOD IS NOT EXTENDABLE.

5. CORRECTED DRAWINGS (as "replacement sheets") must be submitted.
 - including changes required by the attached Examiner's Amendment / Comment or in the Office action of Paper No./Mail Date ____.

Identifying indicia such as the application number (see 37 CFR 1.84(c)) should be written on the drawings in the front (not the back) of each sheet. Replacement sheet(s) should be labeled as such in the header according to 37 CFR 1.121(d).
6. DEPOSIT OF and/or INFORMATION about the deposit of BIOLOGICAL MATERIAL must be submitted. Note the attached Examiner's comment regarding REQUIREMENT FOR THE DEPOSIT OF BIOLOGICAL MATERIAL.

Attachment(s)

- | | |
|---|---|
| <ol style="list-style-type: none"> 1. <input type="checkbox"/> Notice of References Cited (PTO-892) 2. <input type="checkbox"/> Information Disclosure Statements (PTO/SB/08), Paper No./Mail Date ____ 3. <input type="checkbox"/> Examiner's Comment Regarding Requirement for Deposit of Biological Material 4. <input type="checkbox"/> Interview Summary (PTO-413), Paper No./Mail Date ____ . | <ol style="list-style-type: none"> 5. <input type="checkbox"/> Examiner's Amendment/Comment 6. <input checked="" type="checkbox"/> Examiner's Statement of Reasons for Allowance 7. <input type="checkbox"/> Other ____. |
|---|---|

/Joshua Joo/
 Primary Examiner, Art Unit 2445

Notice of Allowability

Claims 1-20 are allowed.

Reasons for Allowance

The following is an examiner's statement of reasons for allowance:

Terminal Disclaimers filed on October 24, 2012 were approved.

Prior art of record discloses verifying an authority of a broadcast agent identification including an authority of an originating broadcast agent to send a broadcast message to a broadcast target area.

However, the prior art of record does not teach: storing a geographically defined broadcast message jurisdiction for a broadcast agent; verifying an authority of a broadcast agent identification including an authority of an originating broadcast agent to send a broadcast message to a broadcast target area by comparing the stored geographically defined broadcast message jurisdiction for the originating broadcast agent with the broadcast target area associated with the broadcast message in the broadcast request.

Any comments considered necessary by applicant must be submitted no later than the payment of the issue fee and, to avoid processing delays, should preferably accompany the issue fee. Such submissions should be clearly labeled "Comments on Statement of Reasons for Allowance."

Conclusion

Any inquiry concerning this communication or earlier communications from the examiner should be directed to Joshua Joo whose telephone number is 571 272-3966. The examiner can normally be reached on Monday to Friday 7:30AM to 4:00PM EST.

Application/Control Number: 13/311,448
Art Unit: 2445

Page 3

If attempts to reach the examiner by telephone are unsuccessful, the examiner's supervisor, Lynn Feild can be reached on 571 272-2092. The fax phone number for the organization where this application or proceeding is assigned is 571-273-8300.

Information regarding the status of an application may be obtained from the Patent Application Information Retrieval (PAIR) system. Status information for published applications may be obtained from either Private PAIR or Public PAIR. Status information for unpublished applications is available through Private PAIR only. For more information about the PAIR system, see <http://pair-direct.uspto.gov>. Should you have questions on access to the Private PAIR system, contact the Electronic Business Center (EBC) at 866-217-9197 (toll-free).

/Joshua Joo/
Primary Examiner, Art Unit 2445

Index of Claims 	Application/Control No. 13311448	Applicant(s)/Patent Under Reexamination WOOD ET AL.
	Examiner JOSHUA JOO	Art Unit 2445

✓	Rejected	-	Cancelled	N	Non-Elected	A	Appeal
=	Allowed	÷	Restricted	I	Interference	O	Objected

Claims renumbered in the same order as presented by applicant
 CPA
 T.D.
 R.1.47

CLAIM		DATE							
Final	Original	04/21/2012	12/07/2012						
1	1	✓	=						
2	2	✓	=						
3	3	✓	=						
4	4	✓	=						
5	5	✓	=						
6	6	✓	=						
7	7	✓	=						
8	8	✓	=						
9	9	✓	=						
10	10	✓	=						
11	11	✓	=						
12	12	✓	=						
13	13	✓	=						
14	14	✓	=						
15	15	✓	=						
16	16	✓	=						
17	17	✓	=						
18	18	✓	=						
19	19	✓	=						
20	20	✓	=						

EAST Search History

EAST Search History (Prior Art)

Ref #	Hits	Search Query	DBs	Default Operator	Plurals	Time Stamp
S1	63	broadcast\$3 near10 (message\$1 alert\$1 notification\$1) same jurisdiction	US-PGPUB; USPAT; EPO; JPO; IBM_TDB	OR	OFF	2012/12/07 13:13
S3	30	broadcast\$3 near10 (message\$1 alert\$1 notification\$1) and (verif\$4 verification authority authoriz\$3 authorization) near10 jurisdiction same (send\$3 transmit\$4 broadcast\$3) near10 (message\$1 alert\$1 notification\$1)	US-PGPUB; USPAT; EPO; JPO; IBM_TDB	OR	OFF	2012/12/07 13:56
S5	72	broadcast\$3 near10 (message\$1 alert\$1 notification\$1) and (verif\$4 verification authority authoriz\$3 authorization) near10 (broadcast target geographic\$3) near2 (location area) same (send\$3 transmit\$4 broadcast\$3) near10 (message\$1 alert\$1 notification\$1)	US-PGPUB; USPAT; EPO; JPO; IBM_TDB	OR	OFF	2012/12/07 13:57
S7	94	broadcast\$3 near10 (message\$1 alert\$1 notification\$1) and compar\$3 near10 (broadcast target geographic\$3) near2 (location area) same (send\$3 transmit\$4 broadcast\$3) near10 (message\$1 alert\$1 notification\$1)	US-PGPUB; USPAT; EPO; JPO; IBM_TDB	OR	OFF	2012/12/07 14:13
S9	75	(send\$3 transmit\$4) near10 (message\$1 alert\$1 notification\$1) same (verif\$4 verification authority authoriz\$3 authorization determin\$3) near10 jurisdiction	US-PGPUB; USPAT; EPO; JPO; IBM_TDB	OR	OFF	2012/12/07 14:27
S11	22	mark near2 andrew near2 wood.in.	US-PGPUB; USPAT; EPO; JPO; IBM_TDB	OR	OFF	2012/12/07 14:43
S12	22	kevin near2 russell near2 preston.in.	US-PGPUB; USPAT; EPO; JPO; IBM_TDB	OR	OFF	2012/12/07 14:43
S13	25	douglas near2 weiser.in.	US-PGPUB; USPAT; EPO; JPO; IBM_TDB	OR	OFF	2012/12/07 14:43
S15	26	S11 S12 S13	US-	OR	OFF	2012/12/07

EAST Search History

			PGPUB; USPAT; EPO; JPO; IBM_TDB			14:44
S17	58351	709/203-207,224-225.ccls.	US- PGPUB; USPAT; EPO; JPO; IBM_TDB	OR	OFF	2012/12/07 15:02
S18	76	(verif\$4 verification authority authoriz\$3 authorization) near10 (send\$3 transmit\$4) near10 (message\$1 alert\$1 notification\$1) near10 (broadcast target geographic\$3) near2 (location area)	US- PGPUB; USPAT; EPO; JPO; IBM_TDB	OR	OFF	2012/12/07 15:02
S19	54	(verif\$4 verification authority authoriz\$3 authorization) near10 (sender\$1 agent\$1 user\$1 originator) same (send\$3 transmit\$4) near10 (message\$1 alert\$1 notification\$1) near10 (broadcast target geographic\$3) near2 (location area)	US- PGPUB; USPAT; EPO; JPO; IBM_TDB	OR	OFF	2012/12/07 15:04
S21	661	(verif\$4 verification authority authoriz\$3 authorization) near10 (sender\$1 agent\$1 user\$1 originator) same (send\$3 transmit\$4 broadcast\$3) near10 (message\$1 alert\$1 notification\$1) near10 (location area)	US- PGPUB; USPAT; EPO; JPO; IBM_TDB	OR	OFF	2012/12/07 15:07
S22	81	S17 and S21	US- PGPUB; USPAT; EPO; JPO; IBM_TDB	OR	OFF	2012/12/07 15:08
S23	22	envisionit.as.	US- PGPUB; USPAT; EPO; JPO; IBM_TDB	OR	OFF	2012/12/07 15:21
S25	4146	455/403-404.1.ccls.	US- PGPUB; USPAT; EPO; JPO; IBM_TDB	OR	OFF	2012/12/07 15:21
S26	14	S25 and S21	US- PGPUB; USPAT; EPO; JPO; IBM_TDB	OR	OFF	2012/12/07 15:21
S29	58351	709/203-207,224-225.ccls.	US- PGPUB; USPAT; EPO; JPO; IBM_TDB	OR	OFF	2012/12/10 08:34
S31	544	(verif\$4 verification authority authoriz\$3	US-	OR	OFF	2012/12/10

EAST Search History

		authorization) same (send\$3 transmit\$4 broadcast\$3) near10 (emergency message\$1 alert\$1 notification\$1) same (geographic geographical\$2) near4 (jurisdiction\$1 location\$1 area\$1 region\$1)	PGPUB; USPAT; EPO; JPO; IBM_TDB			08:35
S33	41	S29 and S31	US- PGPUB; USPAT; EPO; JPO; IBM_TDB	OR	OFF	2012/12/10 08:35

12/ 10/ 2012 8:56:44 AM

C:\Users\jjoo\Documents\EAST\Workspaces\13311448b.wsp

Issue Classification 	Application/Control No. 13311448	Applicant(s)/Patent Under Reexamination WOOD ET AL.
	Examiner JOSHUA JOO	Art Unit 2445

ORIGINAL						INTERNATIONAL CLASSIFICATION												
CLASS		SUBCLASS				CLAIMED					NON-CLAIMED							
709		203				G	0	6	F	15 / 16 (2006.0)								
CROSS REFERENCE(S)						G	0	6	F	15 / 173 (2006.0)								
CLASS	SUBCLASS (ONE SUBCLASS PER BLOCK)																	
709	206	225																

<input checked="" type="checkbox"/> Claims renumbered in the same order as presented by applicant <input type="checkbox"/> CPA <input checked="" type="checkbox"/> T.D. <input type="checkbox"/> R.1.47															
Final	Original	Final	Original	Final	Original	Final	Original	Final	Original	Final	Original	Final	Original	Final	Original
1	1	17	17												
2	2	18	18												
3	3	19	19												
4	4	20	20												
5	5														
6	6														
7	7														
8	8														
9	9														
10	10														
11	11														
12	12														
13	13														
14	14														
15	15														
16	16														

NONE	Total Claims Allowed:	
(Assistant Examiner)	(Date)	20
/JOSHUA JOO/ Primary Examiner. Art Unit 2445	12/07/2012	O.G. Print Claim(s) O.G. Print Figure
(Primary Examiner)	(Date)	1 1



UNITED STATES PATENT AND TRADEMARK OFFICE

UNITED STATES DEPARTMENT OF COMMERCE
 United States Patent and Trademark Office
 Address: COMMISSIONER FOR PATENTS
 P.O. Box 1450
 Alexandria, Virginia 22313-1450
 www.uspto.gov

BIB DATA SHEET

CONFIRMATION NO. 9039

SERIAL NUMBER 13/311,448	FILING or 371(c) DATE 12/05/2011	CLASS 709	GROUP ART UNIT 2445	ATTORNEY DOCKET NO. ENIT 9834C2	
APPLICANTS Mark Andrew Wood, Haslemere, UNITED KINGDOM; Kevin Russell Preston, Newport, UNITED KINGDOM; Douglas Weiser, New Port Richey, FL; ** CONTINUING DATA ***** This application is a CON of 12/559,405 09/14/2009 PAT 8,073,903 which is a CON of 11/057,704 02/14/2005 PAT 7,752,259 which claims benefit of 60/544,739 02/13/2004 ** FOREIGN APPLICATIONS ***** ** IF REQUIRED, FOREIGN FILING LICENSE GRANTED ** ** SMALL ENTITY ** 12/16/2011					
Foreign Priority claimed <input type="checkbox"/> Yes <input checked="" type="checkbox"/> No 35 USC 119(a-d) conditions met <input type="checkbox"/> Yes <input checked="" type="checkbox"/> No Verified and Acknowledged <u>/JOSHUA JOO/</u> Examiner's Signature	<input type="checkbox"/> Met after Allowance Initials _____	STATE OR COUNTRY UNITED KINGDOM	SHEETS DRAWINGS 11	TOTAL CLAIMS 20	INDEPENDENT CLAIMS 2
ADDRESS Polster, Lieder, Woodruff & Lucchesi, L.C. 12412 Powerscourt Dr. Suite 200 St. Louis, MO 63131-3615 UNITED STATES					
TITLE BROADCAST ALERTING MESSAGE AGGREGATOR/GATEWAY SYSTEM AND METHOD					
FILING FEE RECEIVED 595	FEES: Authority has been given in Paper No. _____ to charge/credit DEPOSIT ACCOUNT No. _____ for following:		<input type="checkbox"/> All Fees <input type="checkbox"/> 1.16 Fees (Filing) <input type="checkbox"/> 1.17 Fees (Processing Ext. of time) <input type="checkbox"/> 1.18 Fees (Issue) <input type="checkbox"/> Other _____ <input type="checkbox"/> Credit		

EAST Search History

EAST Search History (Interference)

Ref #	Hits	Search Query	DBs	Default Operator	Plurals	Time Stamp
S2	12	broadcast\$3 near5 (message\$1 notification\$1 alert\$1) same jurisdiction.clm.	US-PGPUB; USPAT; UPAD	OR	OFF	2012/12/07 15:39
S3	37	(send\$3 transmit\$4) near5 (message\$1 notification\$1 alert\$1) same jurisdiction.clm.	US-PGPUB; USPAT; UPAD	OR	OFF	2012/12/07 15:41
S6	8	(verif\$4 verification authority authenticat\$5 authoriz\$3 jurisdiction) near10 (agent\$1 sender\$1 user\$1 person\$1) same broadcast\$3 near5 (message\$1 notification\$1 alert\$1) near10 (area location city state region).clm.	US-PGPUB; USPAT; UPAD	OR	OFF	2012/12/07 15:45
S7	197	(verif\$4 verification authority authenticat\$5 authoriz\$3 jurisdiction) near10 (agent\$1 sender\$1 user\$1 person\$1) same (send\$3 transmit\$4) near5 (message\$1 notification\$1 alert\$1) near10 (area location city state region).clm.	US-PGPUB; USPAT; UPAD	OR	OFF	2012/12/07 15:50
S8	10	jurisdiction same broadcast\$3 near10 (target area location).clm.	US-PGPUB; USPAT; UPAD	OR	OFF	2012/12/07 15:55
S9	17	(verif\$4 verification authority authenticat\$5 authoriz\$3 jurisdiction) same (send\$3 transmit\$4) near5 (message\$1 notification\$1 alert\$1) near10 geographic\$3 near3 (area\$1 location\$1 region\$1).clm.	US-PGPUB; USPAT; UPAD	OR	OFF	2012/12/10 08:26

12/ 10/ 2012 8:31:46 AM

C:\Users\jjoo\Documents\EAST\Workspaces\13311448_Interference.wsp

Search Notes 	Application/Control No. 13311448	Applicant(s)/Patent Under Reexamination WOOD ET AL.
	Examiner JOSHUA JOO	Art Unit 2445

SEARCHED			
Class	Subclass	Date	Examiner
709	203-204,224-225	12/7/2012	/JJ/
455	403-404.1	12/7/2012	/JJ/

SEARCH NOTES		
Search Notes	Date	Examiner
Searched in EAST and searched classes/subclasses with keyword combinations. See attached search history.	12/7/2012	/JJ/
Performed Inventor search in PALM and EAST.	12/7/2012	/JJ/
Performed Assignee search in EAST.	12/7/2012	/JJ/

INTERFERENCE SEARCH			
Class	Subclass	Date	Examiner
	Interference search in EAST. See attached Interference search history.	12/7/2012	/JJ/

	/J.J./ Primary Examiner. Art Unit 2445
--	---

PART B - FEE(S) TRANSMITTAL

Complete and send this form, together with applicable fee(s), to: **Mail** **Mail Stop ISSUE FEE**
Commissioner for Patents
P.O. Box 1450
Alexandria, Virginia 22313-1450
 or **Fax** **(571)-273-2885**

INSTRUCTIONS: This form should be used for transmitting the ISSUE FEE and PUBLICATION FEE (if required). Blocks 1 through 5 should be completed where appropriate. All further correspondence including the Patent, advance orders and notification of maintenance fees will be mailed to the current correspondence address as indicated unless corrected below or directed otherwise in Block 1, by (a) specifying a new correspondence address; and/or (b) indicating a separate "FEE ADDRESS" for maintenance fee notifications.

CURRENT CORRESPONDENCE ADDRESS (Note: Use Block 1 for any change of address)

1688 7590 12/11/2012
 Polster, Lieder, Woodruff & Lucchesi, L.C.
 12412 Powerscourt Dr. Suite 200
 St. Louis, MO 63131-3615

Note: A certificate of mailing can only be used for domestic mailings of the Fee(s) Transmittal. This certificate cannot be used for any other accompanying papers. Each additional paper, such as an assignment or formal drawing, must have its own certificate of mailing or transmission.

Certificate of Mailing or Transmission

I hereby certify that this Fee(s) Transmittal is being deposited with the United States Postal Service with sufficient postage for first class mail in an envelope addressed to the Mail Stop ISSUE FEE address above, or being facsimile transmitted to the USPTO (571) 273-2885, on the date indicated below.

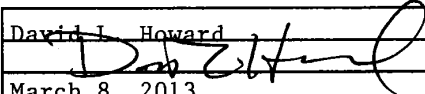
David L. Howard (Depositor's name)
 (Signature)
 March 8, 2013 (Date)

APPLICATION NO.	FILING DATE	FIRST NAMED INVENTOR	ATTORNEY DOCKET NO.	CONFIRMATION NO.
13/311,448	12/05/2011	Mark Andrew Wood	ENIT 9834C2	9039

TITLE OF INVENTION: BROADCAST ALERTING MESSAGE AGGREGATOR/GATEWAY SYSTEM AND METHOD

APPLN. TYPE	SMALL ENTITY	ISSUE FEE DUE	PUBLICATION FEE DUE	PREV. PAID ISSUE FEE	TOTAL FEE(S) DUE	DATE DUE
nonprovisional	YES	\$885	\$300	\$0	\$1185	03/11/2013

EXAMINER	ART UNIT	CLASS-SUBCLASS
JOO, JOSHUA	2445	709-203000

1. Change of correspondence address or indication of "Fee Address" (37 CFR 1.363).
 Change of correspondence address (or Change of Correspondence Address form PTO/SB/122) attached.
 "Fee Address" indication (or "Fee Address" Indication form PTO/SB/47; Rev 03-02 or more recent) attached. **Use of a Customer Number is required.**

2. For printing on the patent front page, list
 (1) the names of up to 3 registered patent attorneys or agents OR, alternatively,
 (2) the name of a single firm (having as a member a registered attorney or agent) and the names of up to 2 registered patent attorneys or agents. If no name is listed, no name will be printed.

1 Polster, Lieder, Woodruff
 & Lucchesi, L.C.
 2 _____
 3 _____

3. ASSIGNEE NAME AND RESIDENCE DATA TO BE PRINTED ON THE PATENT (print or type)

PLEASE NOTE: Unless an assignee is identified below, no assignee data will appear on the patent. If an assignee is identified below, the document has been filed for recordation as set forth in 37 CFR 3.11. Completion of this form is NOT a substitute for filing an assignment.

(A) NAME OF ASSIGNEE

EnvisionIT, LLC

(B) RESIDENCE: (CITY and STATE OR COUNTRY)

St. Charles, MO

Please check the appropriate assignee category or categories (will not be printed on the patent) : Individual Corporation or other private group entity Government

4a. The following fee(s) are submitted:

Issue Fee
 Publication Fee (No small entity discount permitted)
 Advance Order - # of Copies _____

4b. Payment of Fee(s): (Please first reapply any previously paid issue fee shown above)

A check is enclosed.
 Payment by credit card. Form PTO-2038 is attached.
 The Director is hereby authorized to charge the required fee(s), any deficiency, or credit any overpayment, to Deposit Account Number 162201 (enclose an extra copy of this form).

5. Change in Entity Status (from status indicated above)

a. Applicant claims SMALL ENTITY status. See 37 CFR 1.27. b. Applicant is no longer claiming SMALL ENTITY status. See 37 CFR 1.27(g)(2).

NOTE: The Issue Fee and Publication Fee (if required) will not be accepted from anyone other than the applicant; a registered attorney or agent; or the assignee or other party in interest as shown by the records of the United States Patent and Trademark Office.

Authorized Signature

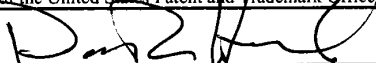

Date March 8, 2013

Typed or printed name David L. Howard

Registration No. 41,502

This collection of information is required by 37 CFR 1.311. The information is required to obtain or retain a benefit by the public which is to file (and by the USPTO to process) an application. Confidentiality is governed by 35 U.S.C. 122 and 37 CFR 1.14. This collection is estimated to take 12 minutes to complete, including gathering, preparing, and submitting the completed application form to the USPTO. Time will vary depending upon the individual case. Any comments on the amount of time you require to complete this form and/or suggestions for reducing this burden, should be sent to the Chief Information Officer, U.S. Patent and Trademark Office, U.S. Department of Commerce, P.O. Box 1450, Alexandria, Virginia 22313-1450. DO NOT SEND FEES OR COMPLETED FORMS TO THIS ADDRESS. SEND TO: Commissioner for Patents, P.O. Box 1450, Alexandria, Virginia 22313-1450.

Under the Paperwork Reduction Act of 1995, no persons are required to respond to a collection of information unless it displays a valid OMB control number.

Electronic Patent Application Fee Transmittal

Application Number:	13311448			
Filing Date:	05-Dec-2011			
Title of Invention:	BROADCAST ALERTING MESSAGE AGGREGATOR/GATEWAY SYSTEM AND METHOD			
First Named Inventor/Applicant Name:	Mark Andrew Wood			
Filer:	David L. Howard/Kim Adler			
Attorney Docket Number:	ENIT 9834C2			
Filed as Small Entity				
Utility under 35 USC 111(a) Filing Fees				
Description	Fee Code	Quantity	Amount	Sub-Total in USD(\$)
Basic Filing:				
Pages:				
Claims:				
Miscellaneous-Filing:				
Petition:				
Patent-Appeals-and-Interference:				
Post-Allowance-and-Post-Issuance:				
Utility Appl Issue Fee	2501	1	885	885
Publ. Fee- Early, Voluntary, or Normal	1504	1	300	300

Description	Fee Code	Quantity	Amount	Sub-Total in USD(\$)
Extension-of-Time:				
Miscellaneous:				
Total in USD (\$)				1185

Electronic Acknowledgement Receipt

EFS ID:	15158752
Application Number:	13311448
International Application Number:	
Confirmation Number:	9039
Title of Invention:	BROADCAST ALERTING MESSAGE AGGREGATOR/GATEWAY SYSTEM AND METHOD
First Named Inventor/Applicant Name:	Mark Andrew Wood
Customer Number:	1688
Filer:	David L. Howard
Filer Authorized By:	
Attorney Docket Number:	ENIT 9834C2
Receipt Date:	08-MAR-2013
Filing Date:	05-DEC-2011
Time Stamp:	15:42:22
Application Type:	Utility under 35 USC 111(a)

Payment information:

Submitted with Payment	yes
Payment Type	Deposit Account
Payment was successfully received in RAM	\$1185
RAM confirmation Number	2994
Deposit Account	162201
Authorized User	

File Listing:

Document Number	Document Description	File Name	File Size(Bytes)/ Message Digest	Multi Part /.zip	Pages (if appl.)
-----------------	----------------------	-----------	-------------------------------------	------------------	------------------

1	Issue Fee Payment (PTO-85B)	ENIT_9834C2_Issue_Fee.pdf	101513 cb9924a1d649f14d305997eb8647439d7b53575	no	1
Warnings:					
Information:					
2	Fee Worksheet (SB06)	fee-info.pdf	32003 f088b891b4da28b0c8435aea664d07dee54a3b18	no	2
Warnings:					
Information:					
Total Files Size (in bytes):			133516		
<p>This Acknowledgement Receipt evidences receipt on the noted date by the USPTO of the indicated documents, characterized by the applicant, and including page counts, where applicable. It serves as evidence of receipt similar to a Post Card, as described in MPEP 503.</p> <p><u>New Applications Under 35 U.S.C. 111</u> If a new application is being filed and the application includes the necessary components for a filing date (see 37 CFR 1.53(b)-(d) and MPEP 506), a Filing Receipt (37 CFR 1.54) will be issued in due course and the date shown on this Acknowledgement Receipt will establish the filing date of the application.</p> <p><u>National Stage of an International Application under 35 U.S.C. 371</u> If a timely submission to enter the national stage of an international application is compliant with the conditions of 35 U.S.C. 371 and other applicable requirements a Form PCT/DO/EO/903 indicating acceptance of the application as a national stage submission under 35 U.S.C. 371 will be issued in addition to the Filing Receipt, in due course.</p> <p><u>New International Application Filed with the USPTO as a Receiving Office</u> If a new international application is being filed and the international application includes the necessary components for an international filing date (see PCT Article 11 and MPEP 1810), a Notification of the International Application Number and of the International Filing Date (Form PCT/RO/105) will be issued in due course, subject to prescriptions concerning national security, and the date shown on this Acknowledgement Receipt will establish the international filing date of the application.</p>					



UNITED STATES PATENT AND TRADEMARK OFFICE

UNITED STATES DEPARTMENT OF COMMERCE
United States Patent and Trademark Office
Address: COMMISSIONER FOR PATENTS
P.O. Box 1450
Alexandria, Virginia 22313-1450
www.uspto.gov

APPLICATION NO.	ISSUE DATE	PATENT NO.	ATTORNEY DOCKET NO.	CONFIRMATION NO.
13/311,448	05/07/2013	8438221	ENTT 9834C2	9039

1688 7590 04/17/2013
Polster, Lieder, Woodruff & Lucchesi, L.C.
12412 Powerscourt Dr. Suite 200
St. Louis, MO 63131-3615

ISSUE NOTIFICATION

The projected patent number and issue date are specified above.

Determination of Patent Term Adjustment under 35 U.S.C. 154 (b)
(application filed on or after May 29, 2000)

The Patent Term Adjustment is 0 day(s). Any patent to issue from the above-identified application will include an indication of the adjustment on the front page.

If a Continued Prosecution Application (CPA) was filed in the above-identified application, the filing date that determines Patent Term Adjustment is the filing date of the most recent CPA.

Applicant will be able to obtain more detailed information by accessing the Patent Application Information Retrieval (PAIR) WEB site (<http://pair.uspto.gov>).

Any questions regarding the Patent Term Extension or Adjustment determination should be directed to the Office of Patent Legal Administration at (571)-272-7702. Questions relating to issue and publication fee payments should be directed to the Application Assistance Unit (AAU) of the Office of Data Management (ODM) at (571)-272-4200.

APPLICANT(s) (Please see PAIR WEB site <http://pair.uspto.gov> for additional applicants):

Mark Andrew Wood, Haslemere, UNITED KINGDOM;
Kevin Russell Preston, Newport, UNITED KINGDOM;
Douglas Weiser, New Port Richey, FL;

The United States represents the largest, most dynamic marketplace in the world and is an unparalleled location for business investment, innovation, and commercialization of new technologies. The USA offers tremendous resources and advantages for those who invest and manufacture goods here. Through SelectUSA, our nation works to encourage and facilitate business investment. To learn more about why the USA is the best country in the world to develop technology, manufacture products, and grow your business, visit SelectUSA.gov.