



**Library of Congress Cataloging-in-Publication Data**

Heine, Gunnar.

GPRS: gateway to third generation mobile networks / Gunnar Heine, Holger Sagkob.

p. cm. — (Artech House mobile communications series)

Includes bibliographical references and index.

ISBN 1-58053-159-8 (alk. paper)

1. Mobile computing. 2. Mobile communication systems. I. Sagkob, Holger. II. Title. III. Series.

QA76.59 .H45 2003  
004.6—dc21

2002043670

**British Library Cataloguing in Publication Data**

Heine, Gunnar

GPRS: gateway to third generation mobile networks. — (Artech House mobile communications series)

1. General Packet Radio Service 2. Global system for mobile communications

I. Title II. Sagkob, Holger

621.3'8456

ISBN 1-58053-159-8

**Cover design by Igor Valdman**

© 2003 ARTECH HOUSE, INC.

685 Canton Street

Norwood, MA 02062

All rights reserved. Printed and bound in the United States of America. No part of this book may be reproduced or utilized in any form or by any means, electronic or mechanical, including photocopying, recording, or by any information storage and retrieval system, without permission in writing from the publisher.

All terms mentioned in this book that are known to be trademarks or service marks have been appropriately capitalized. Artech House cannot attest to the accuracy of this information. Use of a term in this book should not be regarded as affecting the validity of any trademark or service mark.

International Standard Book Number: 1-58053-159-8

Library of Congress Catalog Card Number: 2002043670

10 9 8 7 6 5 4 3 2 1

# 1

## The Basics: Principles of GSM and Influences on GPRS

### 1.1 The Network Architecture of GSM

As an overview, each GSM network can be subdivided into the base station subsystem (BSS) and the network switching subsystem (NSS), as well as the mobile station. Please note that the introduction of GPRS can only expand, but must not change, the existing structure as presented in Figure 1.1, since both types of application—circuit switched and packet switched—should run via the mutual GSM/GPRS network.

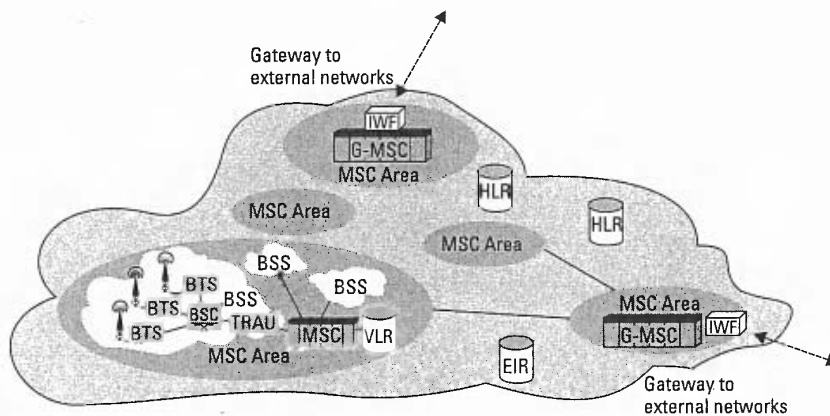

Figure 1.1 GSM network architecture.

## 1.1.1 The BSS

### 1.1.1.1 The Base Transceiver Station

The BSS consists primarily of a larger number of base transceiver stations (BTSs) that enable wireless connection of the mobile stations to the network via the  $U_m$  or air interface (Figure 1.2). Apart from transcoding rate and adaption unit (TRAU) framing, the BTS assumes all layer 1 functions in communications between the network and the mobile station. These include, amongst others, channel coding, interleaving, ciphering (only GSM, not GPRS), and burst generating. Other functions include Gaussian minimum shift keying (GMSK) modulation and demodulation, which are carried out by the base station and will be discussed in detail later.

### 1.1.1.2 The Base Station Controller

All BTSs of a BSS are connected to the base station controller (BSC) via the Abis interface (Figure 1.3). The BSC is, by definition, a circuit switching exchange in addition to the mobile services switching center (MSC), which will be discussed later. The BSC was basically viewed as a further exchange in order to relieve the MSC from all wireless-related tasks. These include, in particular, the evaluation of the measurement results from the BTS and mobile station during a live connection and the handover and power control adjustments resulting from this.

These regulatory functions are generally performed in their entirety by the BSC, although the GSM standard expressly allows preliminary prepar-

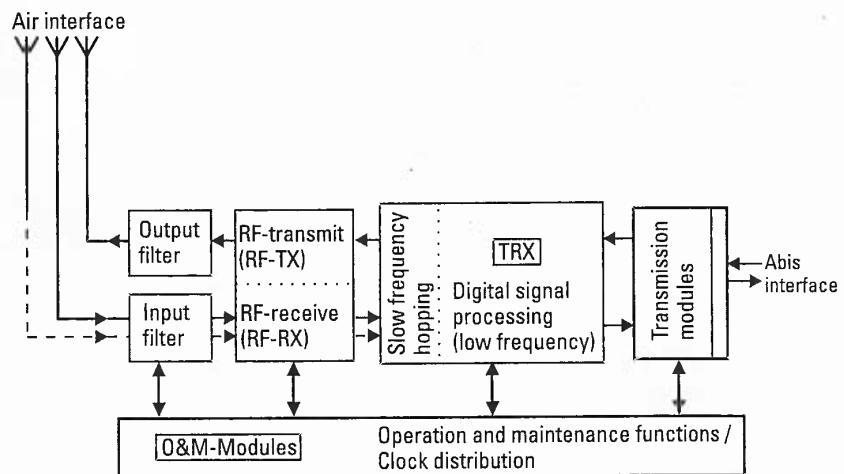
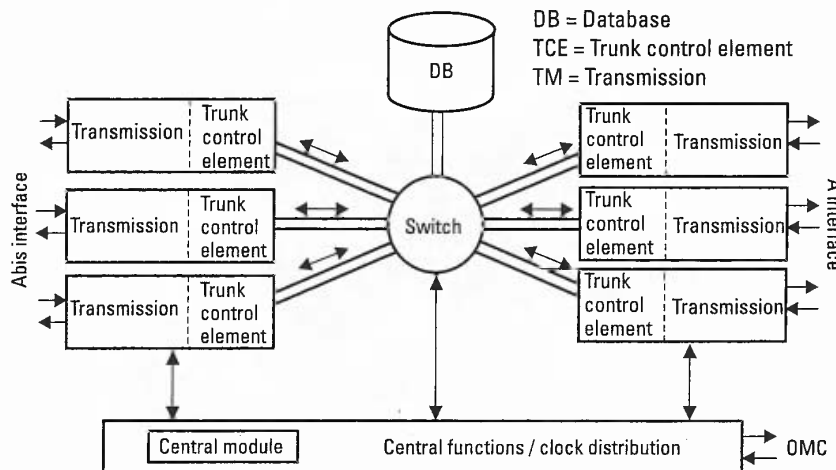

Figure 1.2 Principal schematic diagram of the base transceiver station.



**Figure 1.3** Principal circuit diagram of the BSC.

tion of the measuring results in the BTS. Additional BSC functions are the *Peer* function of the mobile station for the Radio Resource Management protocol (RR) and the resource administration on the Abis and air interface.

The BSC, as a circuit switching network element, is a considerable hindrance to packet switched services (GPRS). Its exchange functions are almost unusable for packet switched services, and the RR protocol is extremely difficult to adjust to the requirements of packet switched services. Hence, if the BSS is to be used at all for GPRS, the BSC must either be modified accordingly or a new network element or an extension of the BSC will be necessary.

#### 1.1.1.3 The Transcoding Rate and Adaptation Unit

The TRAU is the third BSS network element. The best-known task of the TRAU is speech compression from 64 Kbps to 16 Kbps (full-rate) or 8 Kbps (half-rate). The TRAU also carries out comfort noise generation while discontinuous transmission (DTX) is in operation.

What is considerably more important for a basic understanding of signal processing within GSM is another TRAU function: the conversion of all information coming from the MSC into so-called TRAU frames. This conversion is carried out for fax, data, and speech. In other words, all payload transfer between mobile station and TRAU takes place on the basis of TRAU frames. TRAU frames have a length of 320 bits. Every 20 ms a TRAU frame is transmitted or received. Consequently, there are channels of 16 Kbps.

# Explore Litigation Insights

Docket Alarm provides insights to develop a more informed litigation strategy and the peace of mind of knowing you're on top of things.

## Real-Time Litigation Alerts



Keep your litigation team up-to-date with **real-time alerts** and advanced team management tools built for the enterprise, all while greatly reducing PACER spend.

Our comprehensive service means we can handle Federal, State, and Administrative courts across the country.

## Advanced Docket Research



With over 230 million records, Docket Alarm's cloud-native docket research platform finds what other services can't. Coverage includes Federal, State, plus PTAB, TTAB, ITC and NLRB decisions, all in one place.

Identify arguments that have been successful in the past with full text, pinpoint searching. Link to case law cited within any court document via Fastcase.

## Analytics At Your Fingertips



Learn what happened the last time a particular judge, opposing counsel or company faced cases similar to yours.

Advanced out-of-the-box PTAB and TTAB analytics are always at your fingertips.

## API

Docket Alarm offers a powerful API (application programming interface) to developers that want to integrate case filings into their apps.

## LAW FIRMS

Build custom dashboards for your attorneys and clients with live data direct from the court.

Automate many repetitive legal tasks like conflict checks, document management, and marketing.

## FINANCIAL INSTITUTIONS

Litigation and bankruptcy checks for companies and debtors.

## E-DISCOVERY AND LEGAL VENDORS

Sync your system to PACER to automate legal marketing.