



US007584095B2

(12) **United States Patent**  
**Gottesman et al.**

(10) **Patent No.:** **US 7,584,095 B2**  
(45) **Date of Patent:** **\*Sep. 1, 2009**

(54) **REW PARAMETRIC VECTOR  
QUANTIZATION AND DUAL-PREDICTIVE  
SEW VECTOR QUANTIZATION FOR  
WAVEFORM INTERPOLATIVE CODING**

6,418,408 B1 \* 7/2002 Udaya Bhaskar et al. ... 704/219  
6,493,664 B1 \* 12/2002 Udaya Bhaskar et al. ... 704/222  
6,691,092 B1 \* 2/2004 Udaya Bhaskar et al. ... 704/265

(75) Inventors: **Oded Gottesman**, Goleta, CA (US);  
**Allen Gersho**, Goleta, CA (US)

**OTHER PUBLICATIONS**

(73) Assignee: **The Regents of the University of  
California**, Oakland, CA (US)

Oded Gottesman et al., "Enhancing Waveform Interpolative Coding With Weighted REW Parametric Quantization," IEEE Workshop on Speech Coding (2000), pp. 1-3.

(\* ) Notice: Subject to any disclaimer, the term of this patent is extended or adjusted under 35 U.S.C. 154(b) by 98 days.

I.S. Burnett et al., "Multi-Prototype Waveform Coding Using Frame-By-Frame Analysis-By-Synthesis," Department of Electrical and Computer Engineering, University of Wollongong, NSW, Australia (1997), pp. 1567-1570.

This patent is subject to a terminal disclaimer.

I.S. Burnett et al., "New Techniques for Multi-Prototype Waveform Coding at 2.84kb/s," Department of Electrical and Computer Engineering, University of Wollongong, NSW, Australia (1995), pp. 261-264.

(21) Appl. No.: **11/234,631**

I.S. Burnett et al., "Low Complexity Decomposition and Coding of Prototype Waveforms," Dept. of Electrical and Computer Eng., University of Wollongong, NSW, 2522, Australia, pp. 23-24.

(22) Filed: **Sep. 23, 2005**

(Continued)

(65) **Prior Publication Data**

US 2006/0069554 A1 Mar. 30, 2006

*Primary Examiner*—Susan McFadden

(74) *Attorney, Agent, or Firm*—Berliner & Associates

**Related U.S. Application Data**

(62) Division of application No. 09/811,187, filed on Mar. 16, 2001, now Pat. No. 7,010,482.

(60) Provisional application No. 60/190,371, filed on Mar. 17, 2000.

(57) **ABSTRACT**

An enhanced analysis-by-synthesis waveform interpolative speech coder able to operate at 2.8 kbps. Novel features include dual-predictive analysis-by-synthesis quantization of the slowly-evolving waveform, efficient parametrization of the rapidly-evolving waveform magnitude, and analysis-by-synthesis vector quantization of the rapidly evolving waveform parameter. Subjective quality tests indicate that it exceeds G.723.1 at 5.3 kbps, and of G.723.1 at 6.3 kbps.

(51) **Int. Cl.**  
**G10L 19/14** (2006.01)

(52) **U.S. Cl.** ..... **704/222**

(58) **Field of Classification Search** ..... 704/222  
See application file for complete search history.

(56) **References Cited**

**U.S. PATENT DOCUMENTS**

5,924,061 A \* 7/1999 Shoham ..... 704/218

**18 Claims, 6 Drawing Sheets**

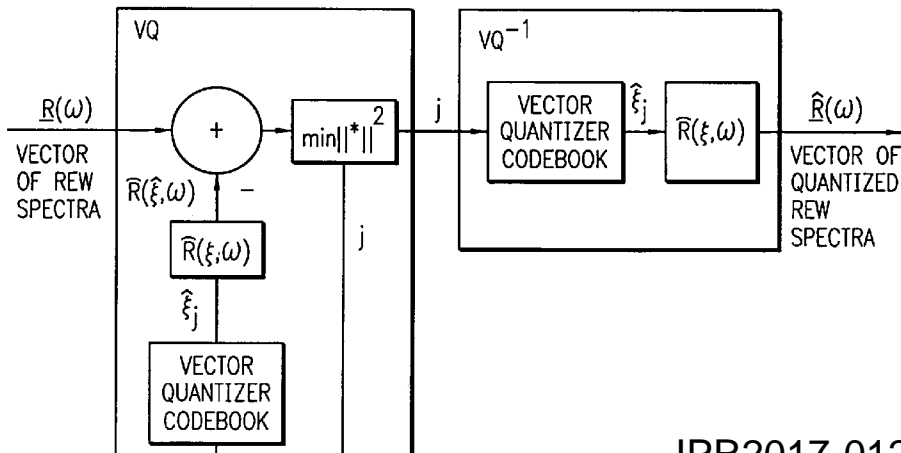

IDR2017-01244

## OTHER PUBLICATIONS

- I.S. Burnett et al., "A Mixed Prototype Waveform/CELP Coder for Sub 3KB/S," School of Electronic and Electrical Engineering, University of Bath, U.K. BA2 7AY (1993), pp. II-175-II-178.
- Oded Gottesman, "Dispersion Phase Vector Quantization for Enhancement of Waveform Interpolative Coder," Signal Compression Laboratory, Department of Electrical and Computer Engineering, University of California, Santa Barbara, California 93106, USA, pp. 1-4.
- Oded Gottesman et al., "Enhanced Waveform Interpolative Coding at 4 KBPS," Signal Compression Laboratory, Department of Electrical and Computer Engineering, University of California, Santa Barbara, California 93106, USA, pp. 1-3.
- Oded Gottesman et al., "High Quality Enhanced Waveform Interpolative Coding at 2.8 KBPS," IEEE International Conference on Acoustics, Speech, and Signal Processing, 2000, pp. 1-4.
- Oded Gottesman et al., "Enhanced Analysis-by-Synthesis Waveform Interpolative Coding at 4 KBPS," Signal Compression Laboratory, Department of Electrical and Computer Engineering, University of California, Santa Barbara, California 93106, USA, pp. 1-4.
- Daniel W. Griffin et al., "Multiband Excitation Vocoder," IEEE Transactions on Acoustics, Speech, and Signal Processing (1988) 36(8):1223-1235.
- W. Bastiaan Kleijn et al., "A Speech Coder Based on Decomposition of Characteristic Waveforms," IEEE (1995), p. 508-511.
- W. Bastiaan Kleijn et al., "Waveform Interpolation for Coding and Synthesis," Speech Coding and Synthesis (1995), pp. 175-207.
- W. Bastiaan Kleijn et al., "Transformation and Decomposition of the Speech Signal for Coding," IEEE Signal Processing Letters 1(9):136-138 (1994).
- W. Bastiaan Kleijn, "Encoding Speech Using Prototype Waveforms," IEEE Transactions on Speech and Audio Processing 1(4):386-399 (1993).
- W. Bastiaan Kleijn, "Continuous Representations in Linear Predictive Coding," Speech Research Department, AT&T Bell Laboratories, Murray Hill, NJ 07974 (1991), pp. 201-204.
- W. Bastiaan Kleijn et al., "A Low-Complexity Waveform Interpolation Coder," Speech Coding Research Department, AT&T Bell Laboratories, 600 Mountain Avenue, Murray Hill, NJ 07974, USA (1996), pp. 212-215.
- R.J. McAulay et al., "Sinusoidal Coding," Speech Coding and Synthesis 4:121-173 (1995).
- Yair Shoham, "High-Quality Speech Coding at 2.4 to 4.0 KBPS Based on Time-Frequency Interpolation," IEEE, pp. II-167-II-170 (1993).
- Yair Shoham, "Very Low Complexity Interpolative Speech Coding at 1.2 to 2.4 KBPS," IEEE, pp. 1599-1602 (1997).
- Yair Shoham, "Low Complexity Speech Coding at 1.2 to 2.4 kbps Based on Waveform Interpolation," International Journal of Speech Technology 2:329-341 (1999).

\* cited by examiner

FIG. 1

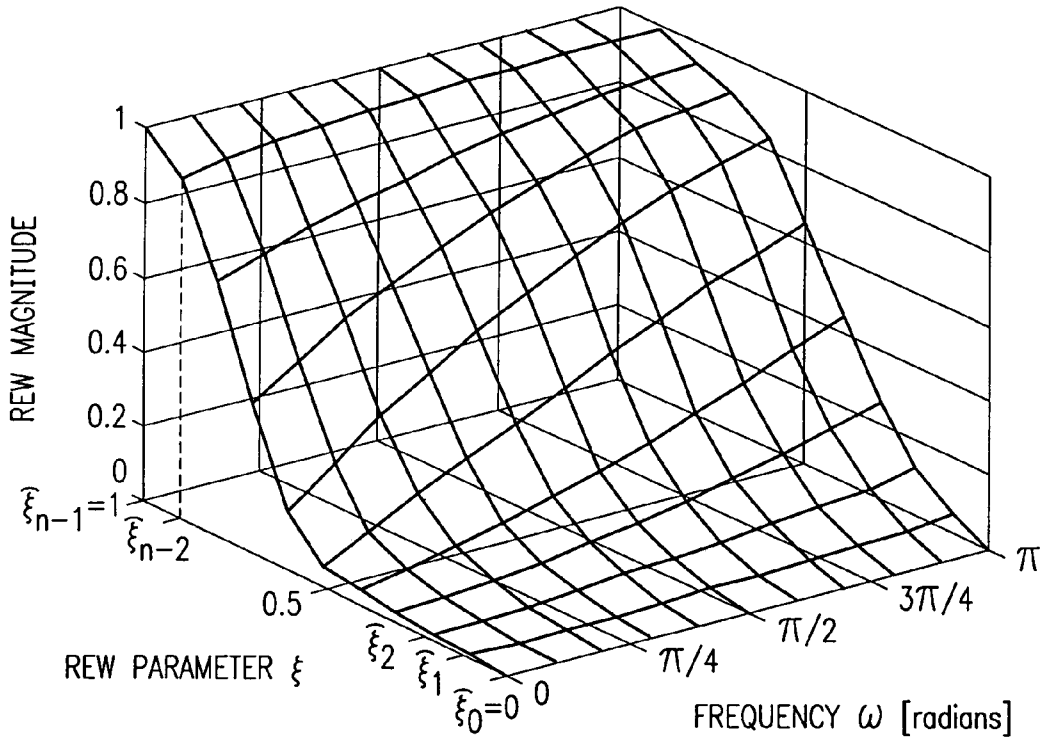

FIG. 2

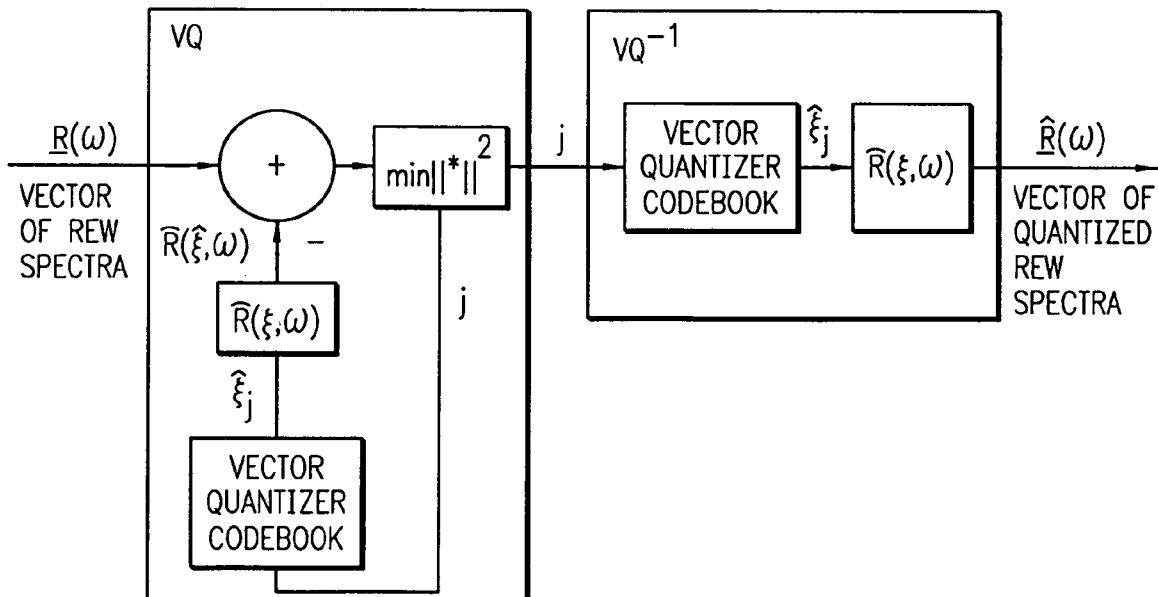
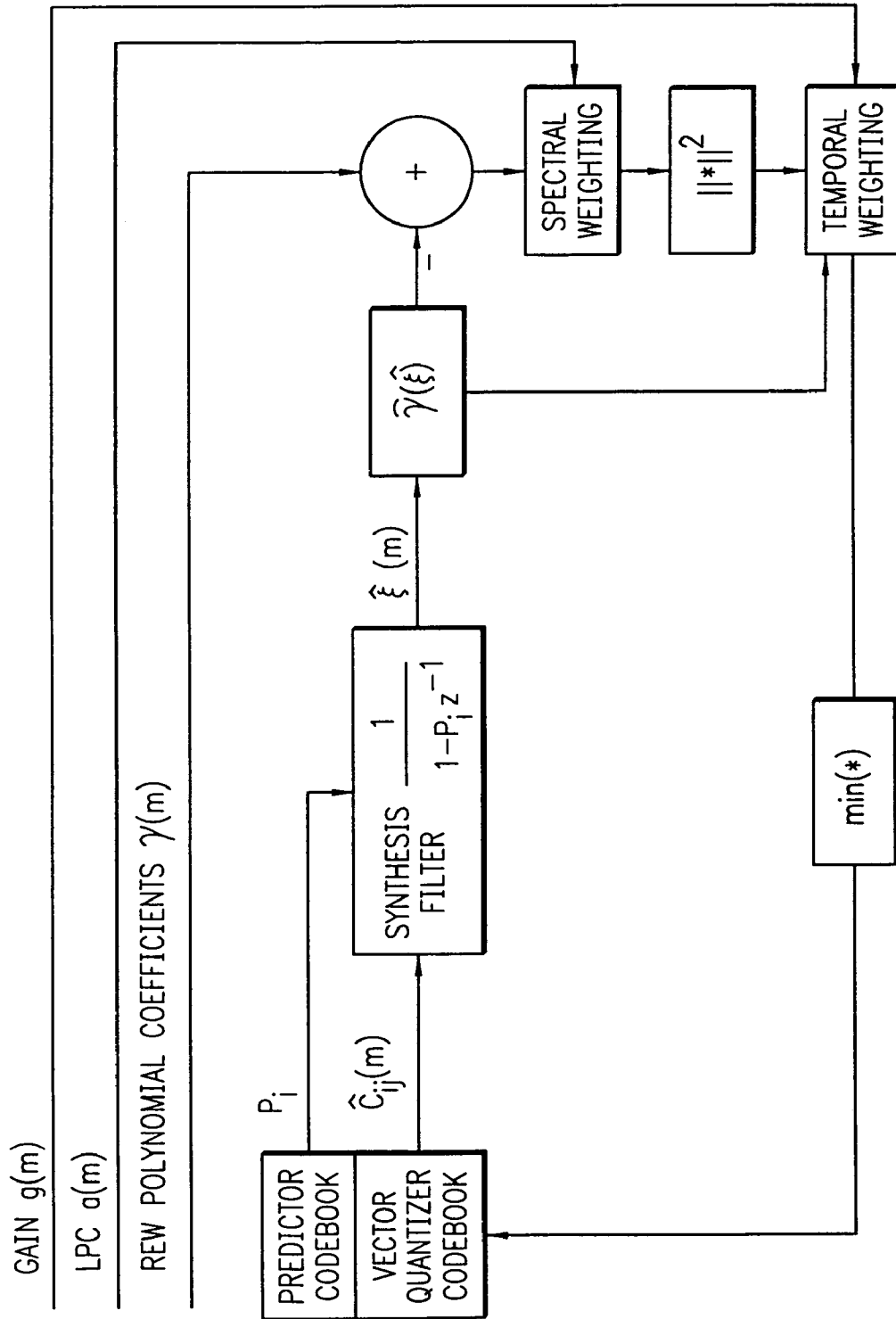
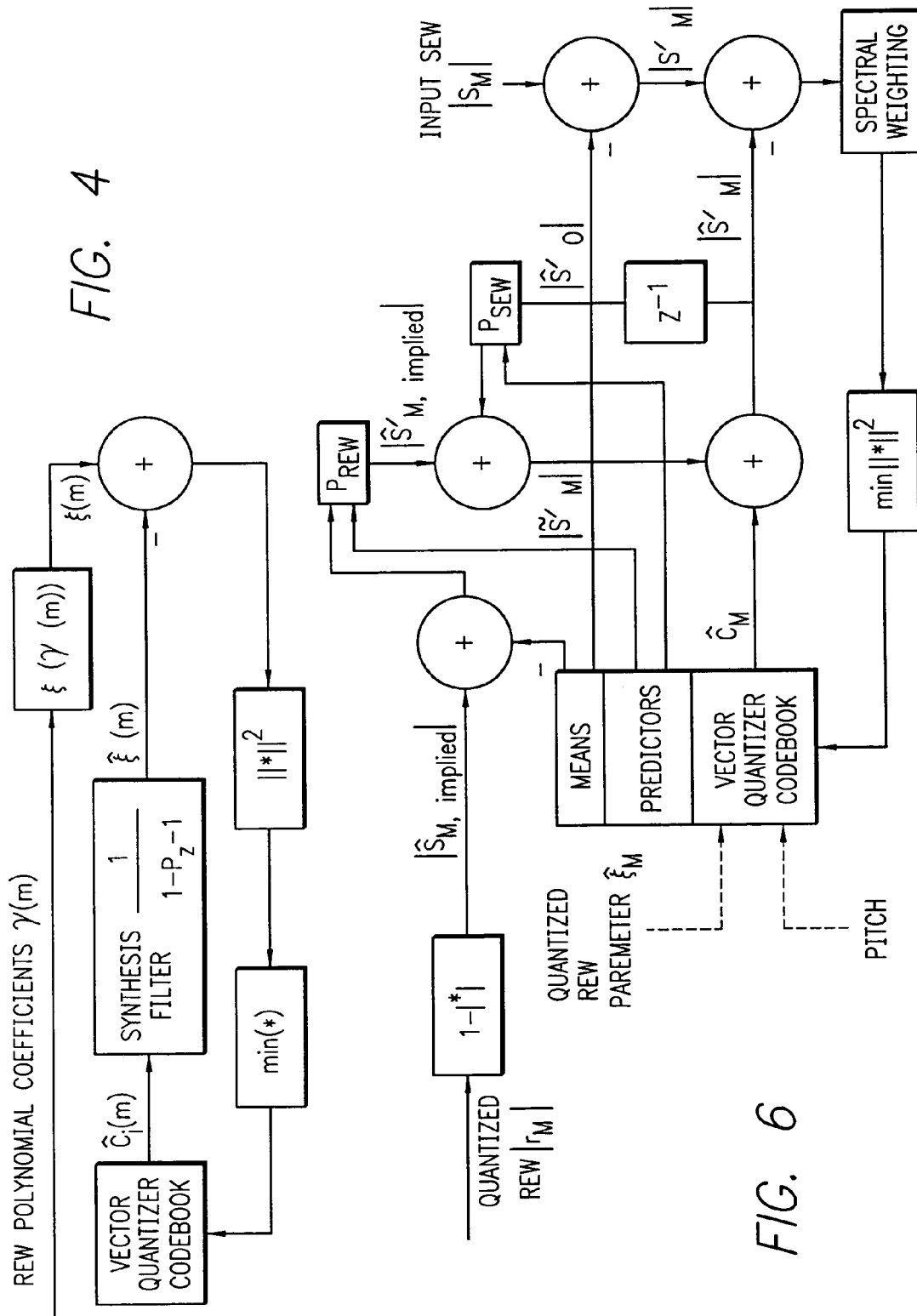

FIG. 3





# Explore Litigation Insights

Docket Alarm provides insights to develop a more informed litigation strategy and the peace of mind of knowing you're on top of things.

## Real-Time Litigation Alerts



Keep your litigation team up-to-date with **real-time alerts** and advanced team management tools built for the enterprise, all while greatly reducing PACER spend.

Our comprehensive service means we can handle Federal, State, and Administrative courts across the country.

## Advanced Docket Research



With over 230 million records, Docket Alarm's cloud-native docket research platform finds what other services can't. Coverage includes Federal, State, plus PTAB, TTAB, ITC and NLRB decisions, all in one place.

Identify arguments that have been successful in the past with full text, pinpoint searching. Link to case law cited within any court document via Fastcase.

## Analytics At Your Fingertips



Learn what happened the last time a particular judge, opposing counsel or company faced cases similar to yours.

Advanced out-of-the-box PTAB and TTAB analytics are always at your fingertips.

## API

Docket Alarm offers a powerful API (application programming interface) to developers that want to integrate case filings into their apps.

## LAW FIRMS

Build custom dashboards for your attorneys and clients with live data direct from the court.

Automate many repetitive legal tasks like conflict checks, document management, and marketing.

## FINANCIAL INSTITUTIONS

Litigation and bankruptcy checks for companies and debtors.

## E-DISCOVERY AND LEGAL VENDORS

Sync your system to PACER to automate legal marketing.