



[54] LINEAR PREDICTION SPEECH CODING WITH HIGH-FREQUENCY PREEMPHASIS

[75] Inventors: Makio Makamura; Yoshihiro Unno, both of Tokyo, Japan

[73] Assignee: NEC Corporation, Tokyo, Japan

[21] Appl. No.: 765,737

[22] Filed: Sep. 26, 1991

[30] Foreign Application Priority Data

Sep. 26, 1990 [JP] Japan 2-256493

[51] Int. Cl.⁵ G10L 3/02; H04B 1/66

[52] U.S. Cl. 315/2.32; 395/2.28; 395/2.29

[58] Field of Search 395/2; 381/29-36, 381/46, 47

[56] References Cited

U.S. PATENT DOCUMENTS

4,899,385	2/1990	Ketchum et al.	395/2
4,933,957	6/1990	Bottau et al.	395/2
4,965,789	10/1990	Bottau et al.	381/31
5,007,092	4/1991	Galand et al.	381/36
5,142,583	8/1992	Galand et al.	381/38

FOREIGN PATENT DOCUMENTS

0331858	8/1988	Japan	G10L 9/14
WO86/02726	5/1986	World Int. Prop. O.	G10L 5/00

OTHER PUBLICATIONS

"Code-excited linear prediction: High quality speech at very low bit rates", ICASSP, vol. 3, pp. 937-940, Mar. 1985.

Signal Processing IV: Theories and Applications (Proceedings of EUSIPCO-88, 4th European Signal Processing Conference, Grenoble, Sep. 5-8, 1988), vol. II, pp. 871-874, F. Bottau et al: "On different vector predictive coding schemes and their application to low bit rates speech coding."

ICASSP'89 (1989 Intl. Conf. on Acoustics, Speech, and Signal Processing, Glasgow, May 23-26, 1989) vol. 1, pp. 132-135, IEEE, J. Menez et al.: "Adaptive code excited linear predictive coder."

IEEE Journal on Selected Areas in Communications,

vol. 6, No. 2, Feb. 1988, pp. 353-363, P. Kroon et al.: "A class of analysis-by-synthesis predictive coders for high quality speech coding at rates between 4.8 and 16 kbits/s."

ICASSP'86 (IEEE-IECEJ-ASJ Int. Conf. on Acoustics, Speech, and Signal Processing, Apr. 7-11, 1986), vol. 4, pp. 3055-3057, IEEE, G. Davidson et al.: "Complexity reduction methods for vector excitation coding."

ICASSP'89 (1989 Intl. Conf. on Acoustics, Speech and Signal Processing, Glasgow, May 23-26, 1989) vol. 1, pp. 53-56, IEEE, A Bergstrom et al: "Codebook driven glottal pulse analysis."

ICASSP'90 (1990 Int. Conf. on Acoustics, Speech, and Signal Processing, Albuquerque, N.M., Apr. 3-6, 1990) vol. 1, pp. 241-244, T. Taniguchi et al: "Principal axis extracting vector excitation coding: high quality speech at 8 kb.s."

Primary Examiner—David D. Knepper
Attorney, Agent, or Firm—Sughrue, Mion, Zinn, Macpeak & Seas

[57] ABSTRACT

High frequency components of input digital speech samples are emphasized by a preemphasis filter (11). From the preemphasized samples a spectral parameter (a_i) is derived at frame intervals. The input digital samples are weighted by a weighting filter (13) according to a characteristic that is inverse to the characteristic of the preemphasis filter (11) and is a function of the spectral parameter (a_i). A codebook (18, 19) is searched for an optimum fricative value in response to a pitch parameter that is derived by an adaptive codebook (16) from a previous fricative value (v(n)) and a difference between the weighted speech samples and synthesized speech samples which are, in turn, derived from past pitch parameters and optimum fricative values, whereby the difference is reduced to a minimum. Index signals representing the spectral parameter, pitch parameter and optimum fricative value are multiplexed into a single data stream.

4 Claims, 4 Drawing Sheets

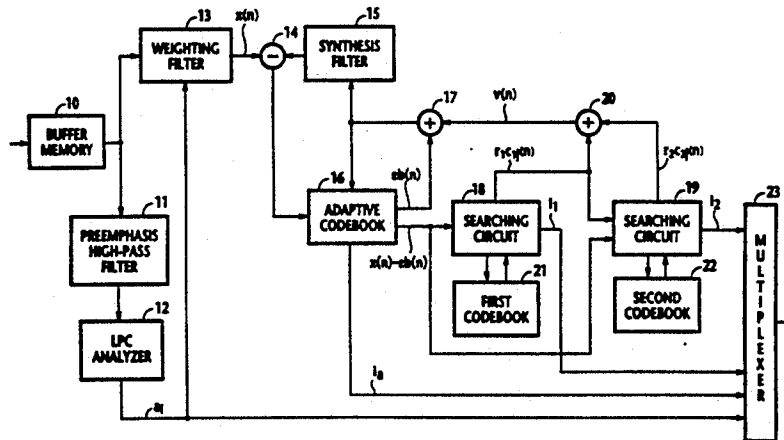

FIG. 1

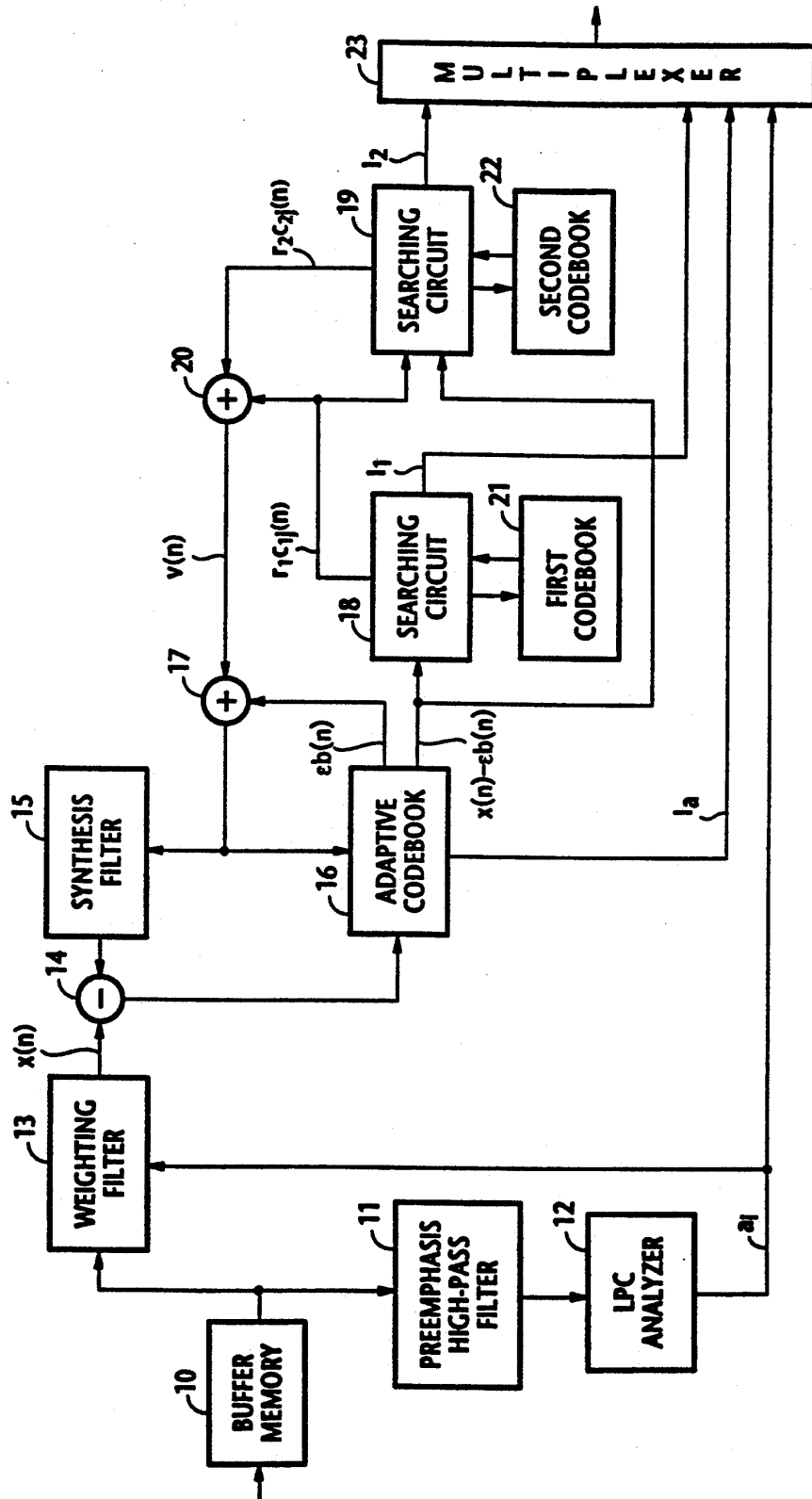

FIG. 2

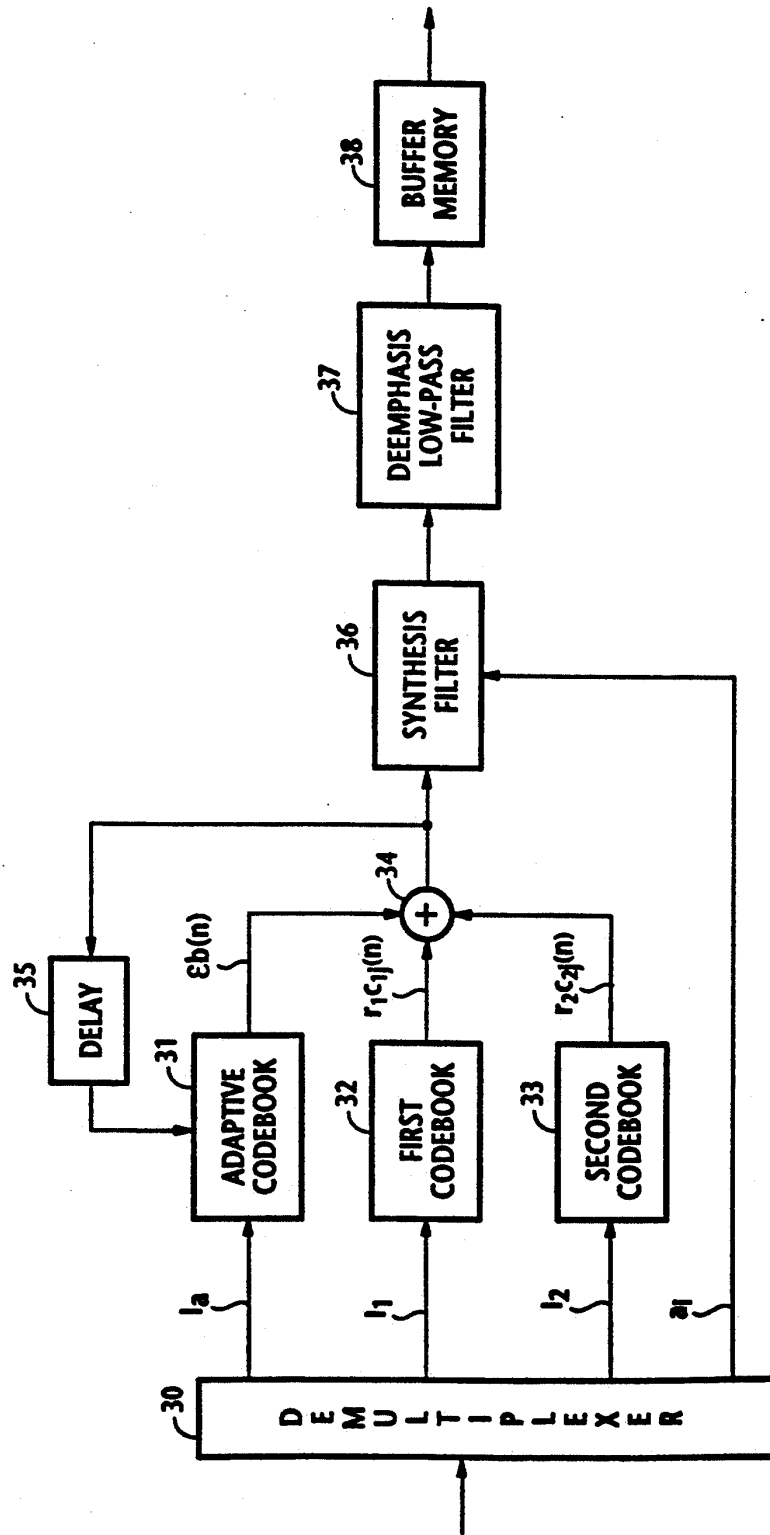

FIG. 3

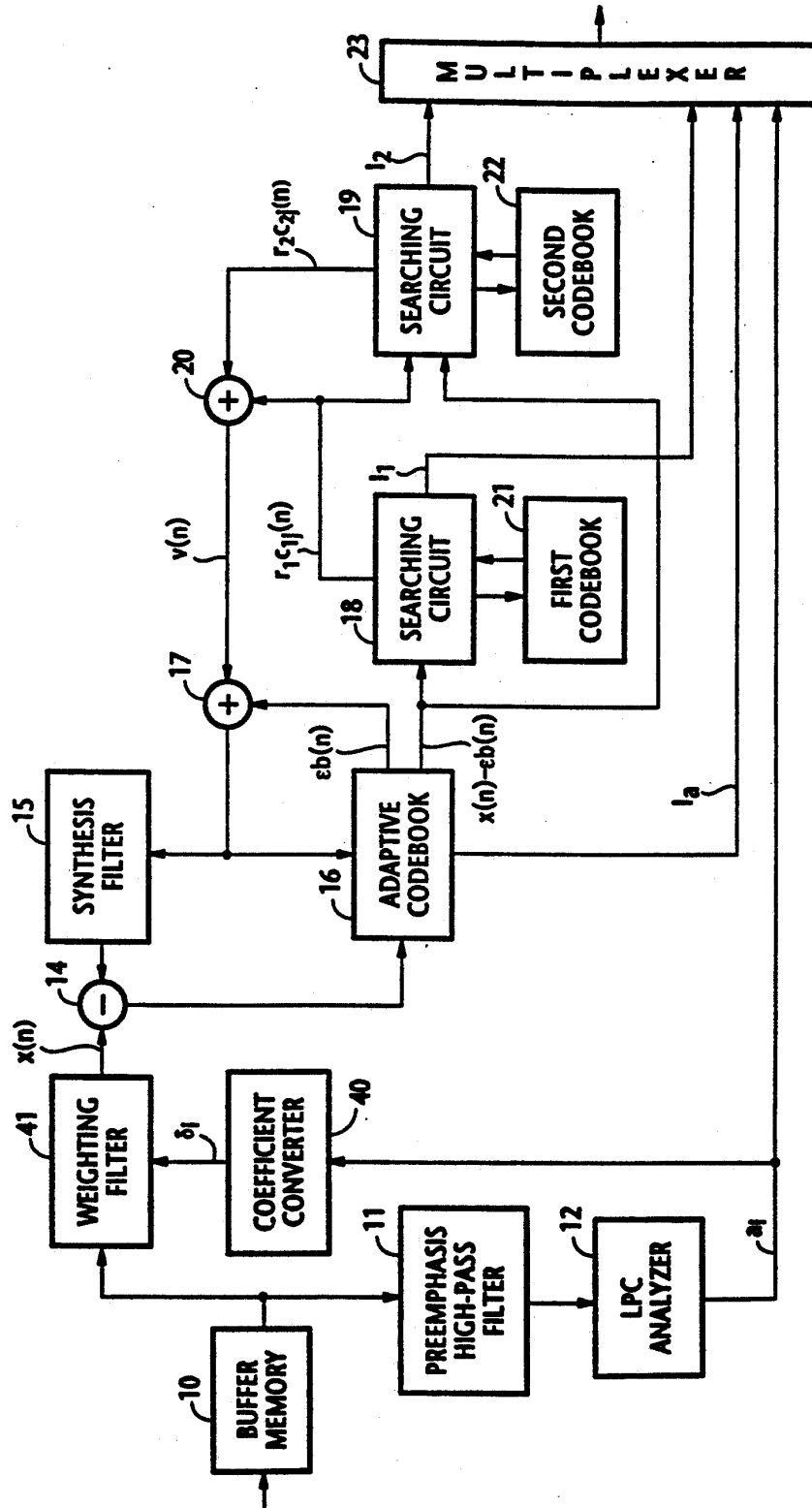
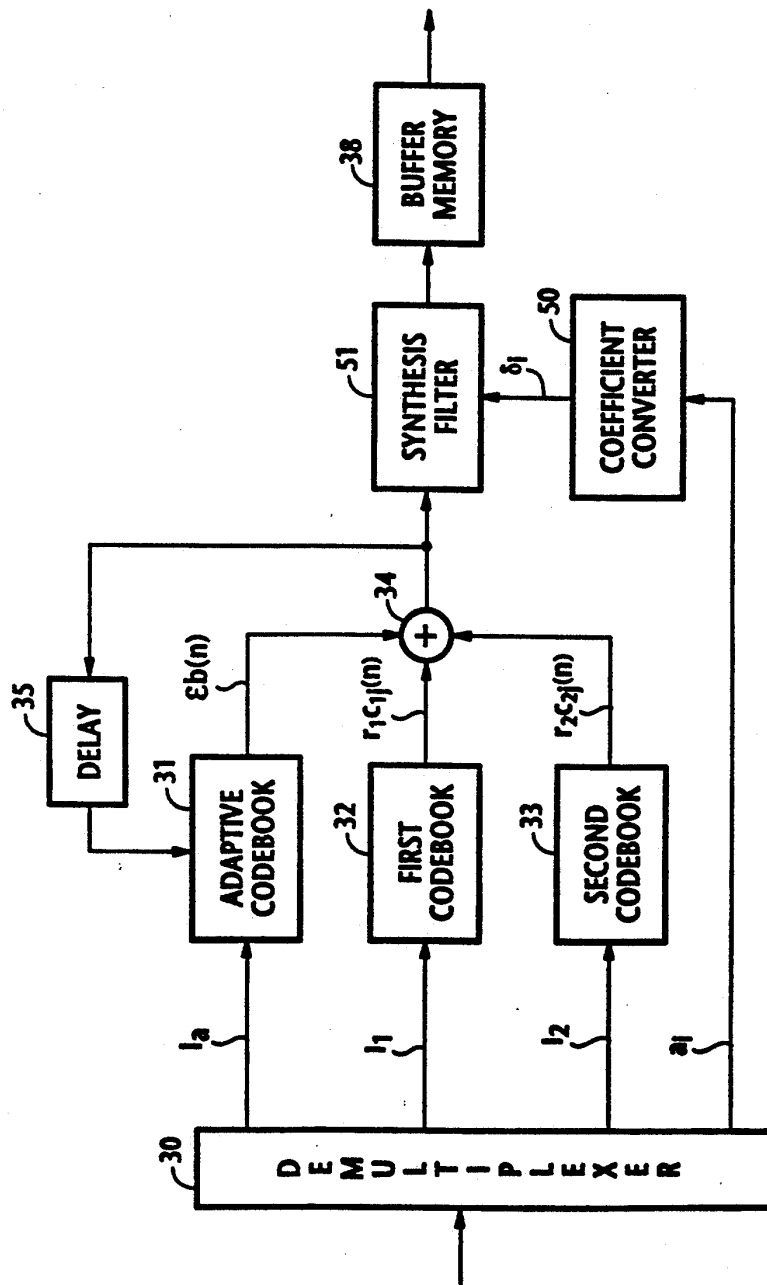

FIG. 4



Explore Litigation Insights

Docket Alarm provides insights to develop a more informed litigation strategy and the peace of mind of knowing you're on top of things.

Real-Time Litigation Alerts



Keep your litigation team up-to-date with **real-time alerts** and advanced team management tools built for the enterprise, all while greatly reducing PACER spend.

Our comprehensive service means we can handle Federal, State, and Administrative courts across the country.

Advanced Docket Research



With over 230 million records, Docket Alarm's cloud-native docket research platform finds what other services can't. Coverage includes Federal, State, plus PTAB, TTAB, ITC and NLRB decisions, all in one place.

Identify arguments that have been successful in the past with full text, pinpoint searching. Link to case law cited within any court document via Fastcase.

Analytics At Your Fingertips



Learn what happened the last time a particular judge, opposing counsel or company faced cases similar to yours.

Advanced out-of-the-box PTAB and TTAB analytics are always at your fingertips.

API

Docket Alarm offers a powerful API (application programming interface) to developers that want to integrate case filings into their apps.

LAW FIRMS

Build custom dashboards for your attorneys and clients with live data direct from the court.

Automate many repetitive legal tasks like conflict checks, document management, and marketing.

FINANCIAL INSTITUTIONS

Litigation and bankruptcy checks for companies and debtors.

E-DISCOVERY AND LEGAL VENDORS

Sync your system to PACER to automate legal marketing.