

electronics

A McGRÁW-HILL PUBLICATION

FEBRUARY • 1956

FEB 3 1956

CHECKING SHOES FOR MISPLACED TACKS—Inspection of shoe insoles for protruding metal is speeded at E. W. Wright & Co. factory by using detector developed by United Shoe Machinery engineers (see p 144) . COVER

H. W. MATEER, *Publisher*

W. W. MacDONALD, *Editor*

VIN ZELUFF, *Managing Editor*

JOHN MARKUS, *Associate Editor*

ALEXANDER A. MCKENZIE, *Associate Editor*

JOHN M. CARROLL, *Associate Editor*

WILLIAM P. O'BRIEN, *Assistant Editor*

WILLIAM G. ARNOLD, *Assistant Editor*

DAVID A. FINDLAY, *Assistant Editor*

HAIG A. MANOOGIAN, *Assistant Editor*

GLORIA J. FILIPPONE, *Editorial Assistant*

ARLENE SCHILP, *Editorial Assistant*

FRANCES SULLIVAN, *Editorial Assistant*

CAROLE A. MORRIS, *Editorial Assistant*

GLADYS T. MONTGOMERY, *Washington Editor*

HARRY PHILLIPS, *Art Director*

SHOPTALK 2

FIGURES OF THE MONTH 6

INDUSTRY REPORT 7

Government Outlines Spending....	7	New Models Ready For '56.....	20
SAGE Readies Sunday Punch.....	7	Will Sun Spots Boost Sales?.....	20
Shield Receivers, FCC Warns.....	8	TV Stations Equip For Color.....	22
Industry's Future Grows Brighter..	8	Small-Boat Electronics.....	22
Transistors Progress.....	10	Equipment Emphasizes Batteries..	22
Scatter Circuit Authorized.....	12	Transmitter Antenna Sales Up.....	24
Research And Development Gains..	12	Conelrad Extends Radio Blackout..	24
F-M Stations Take On New Business	12	Selenium Shortage May Be Eased..	24
Magnetic Recording Sales Rise....	14	Financial Roundup.....	26
TV Networks Swing To Microwave..	14	Marines Land Radar.....	26
Germanium Rectifiers Save Space..	16	Future Meetings.....	26
Automatic Production Makes Jobs..	16	Industry Shorts.....	26
Finance Firms Take To Electronics	20		

CROSSTALK 121

FEATURES

Electronic Controls for Machine Tools.....	122
By David A. Findlay	
Broadband Antenna for Field-Intensity Meters.....	130
By Edward N. Singer and Herschel R. Caler	
Character Recognition for Business Machines.....	132
By M. H. Glauberman	
Diffusion Transistors Raise Frequency Limits.....	137
By John M. Carroll	
Magnetic Amplifier Two-Speed Servo System.....	140
By Joseph John Suozzi	
Tack Detector for Shoe Production.....	144
By Robert W. Bradley	
Airborne Weather Radar Uses Isoecho Circuit.....	147
By F. W. Ruppert and J. M. Smith	
Automatic Measurement of Voltage Tolerances.....	150
By A. J. Strassman	

WALLACE B. BLOOD, *Manager*

R. S. QUINT, *Buyers' Guide Manager*

FRANK H. WARD, *Business Manager*

GEORGE E. POMEROY, *Classified Manager*

DONALD H. MILLER, *New York*

JAMES GIRDWOOD, *New York*

WM. S. HODGKINSON, *New England*

JAMES T. HAUPTLI, *Philadelphia*

CHARLES WARDNER, *Chicago*

BRUCE WINNER, *Chicago*

HENRY M. SHAW, *Cleveland*

T. H. CARMODY, *San Francisco*

R. C. ALCORN, *San Francisco*

CARL W. DYSINGER, *Los Angeles*

WM. D. LANIER, *Atlanta*

JAMES H. CASH, *Dallas*

KEITH HENNEY, *Consultant*

Character Recognition

SUMMARY — Photoelectric scanner analyzes printed numerals and provides electrical output usable in computers and other business machines. Reader recognizes 400 characters per second. Operation is independent of type style or size of number above minimum width

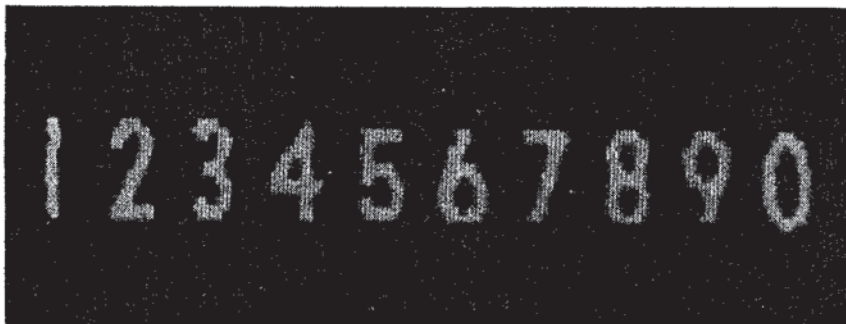

Numerals printed by character reader

By M. H. GLAUBERMAN

Senior Engineer
Laboratory for Electronics, Inc.
Boston, Massachusetts

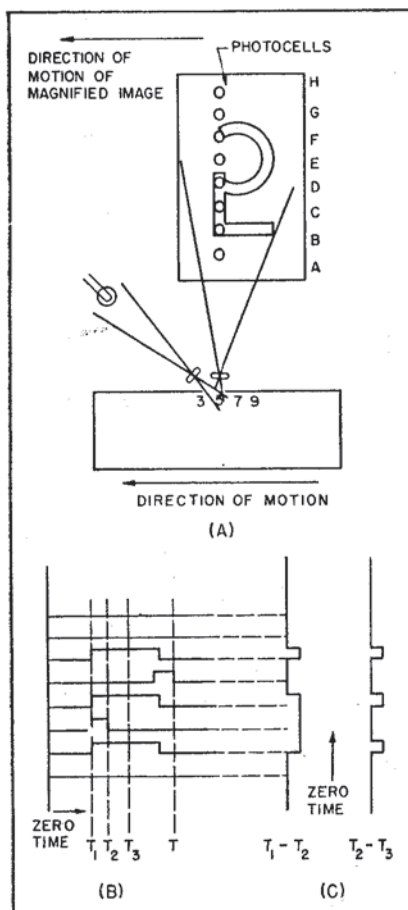

THIS READER recognizes Arabic numerals as printed matter passes through it.

Paper is not restricted as to color, thickness, opacity, roughness or quality. Ink need have no special qualities. The depth of the impression on the paper is of no significance, and at no time does the reader come into contact with the paper.

The character reader cannot read all type styles, but is not dependent on any one style. Minimum type width is approximately $\frac{1}{8}$ in. for the widest digit. There is no restriction on maximum type width. The reader is not dependent on the height of the type providing the size is not larger than the aperture of the reading station. A common type height is about $\frac{1}{8}$ inch. Most print imperfections will not impair recognition.

With checks moving into the reader at 16 per second, it recognizes 400 characters per second. The reader is able to read 1,600 characters per second, however, and could be made to operate at twice

serially and sorts by successive passes.

Photoelectric Scanner

The scanner consists of a column of photocells whose outputs are modulated by the black portions of characters. The photocells are sequentially gated into a common buffer. Figure 1A shows how a magnified image of a number is projected on the photocells. Figure 2 shows the scanner circuits.

Figure 1B shows the photocell outputs. The effect of sequentially gating the outputs into a common buffer is shown in Fig. 1C.

Table I—Pulse-Code Combination

Total Pulses Per Scan	Long-Black Pulses Per Scan	Coded Combination
1	0	10
1	1	11
2	0	20
2	1	21\21'
2	2	22
3	0	30\30'
3	1	31

Note that the first digit of the coded combination represents the total number of black pulses per scan and the second digit represents

for Business Machines

There are photocells above and below those required to cover the number to accommodate changes in the vertical registry. See Fig. 3. Each photocell is an input to a gate whose other input is connected to a tap of a multiple-tapped delay line. The outputs of the gates are combined in the common buffer *B*.

Each photocell is individually connected to network *B* by sending a pulse down the multiple-tapped delay line. A pulse sent down the delay line corresponds to a scan. No attempt is made to synchronize the start of a scan with the entry of a character under the column of photocells.

The uncertainty of the start of the scan with respect to the edge of the character to be scanned is called horizontal registry. The character reader overcomes this registry problem by utilizing the first scan not to recognize the character but to tell the recognition circuit to look for recognition on the second scan.

Pulse Generator

The waveforms at the output of combining network *B* appear as in Fig. 1C. The total pulse generator produces one pulse for each black region of the number and serves as a noise filter in that an input pulse must exceed a certain width for an output pulse to be generated.

The long-black pulse generator (see Fig. 4) is also a pulse-width detector. In this case a pulse must exceed a predetermined length for a long-black pulse to be generated. For example, a pulse must equal or exceed the length shown in Fig. 1C.

The output of the total pulse generator and of the long-black pulse generator, along with the system trigger, are next sent to the encoder unit. Three pulses, each appearing once during every scan period, are derived from the tapped delay line and also sent to the encoder. These pulses, in the order of their time sequence, are the comparison pulse, the read-out pulse and the reset pulse.

Six instructions constitute the

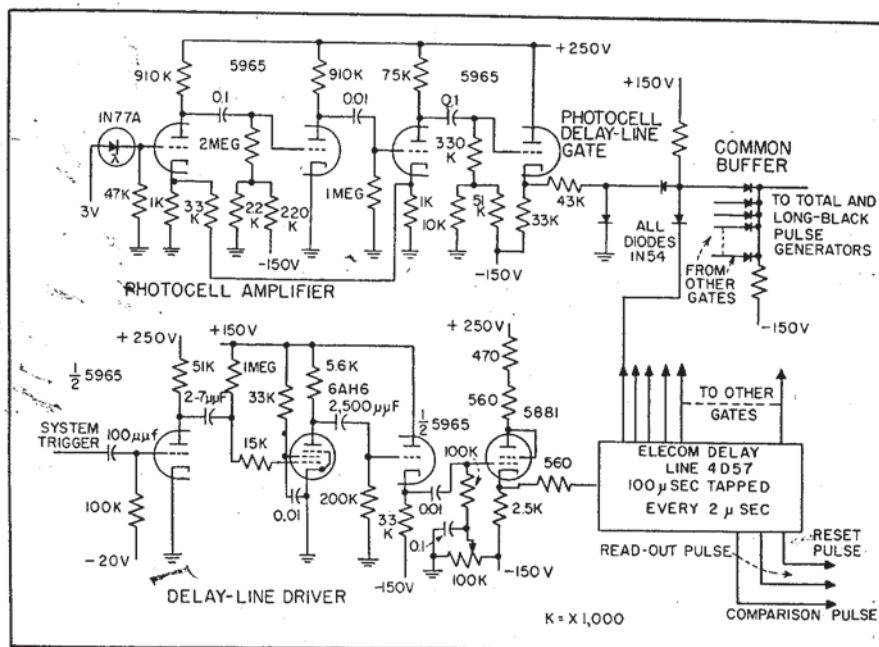

FIG. 2—Input section showing photodiode and delay line

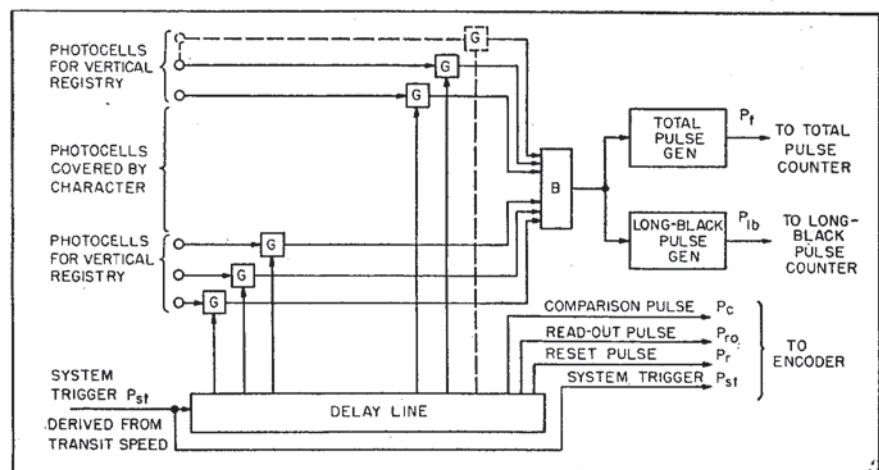

FIG. 3—Scanning station of character reader

program of the character reader.

(1) Count the total number of black pulses per scan.

(2) Count the number of long-black pulses per scan.

(3) Combine the results into discrete combinations as shown in Table I.

(4) If adjacent scans are not identical, put the most recent scan into shift-register storage and shift the register.

(5) If adjacent scans are identical, put nothing into storage and do not shift the register.

(6) When there is no character under the reading station advance

the register but put nothing into storage.

A block diagram of the encoding unit shown in Fig. 5. The system trigger P_{st} operates an electronic switch which routes the total pulses P_t alternately into total-pulse counter *A* and total pulse counter *B* through gates G_a . The electronic switch also routes the long-black pulses P_{lb} into long-black counter *A* and long-black counter *B*, alternately, through gates G_b .

Scan Comparison

Alternately switching input information P_t and P_{lb} into pairs of

Table II—Shift Register Storage (Numeral Three)

1 Scan	2 Total	3 Long	4 Code	5 Identity	6 Read-in	7 Shift	8 Interrogate	9 1st read-in in core row	10 2nd read-in in core row	11 3rd read-in in core row	12 4th read-in in core row
1	1	0	10	no	yes	yes	no	1	—	—	—
2	2	0	20	no	yes	yes	no	2	1	—	—
3	2	0	20	yes	no	yes	no	2	1	—	—
4	2	0	20	yes	no	no	no	2	1	—	—
5	2	0	20	yes	no	no	no	2	1	—	—
6	3	0	30 ¹	no	yes	no	no	2	1	—	—
7	3	0	30 ¹	yes	yes	yes	no	3	2	1	—
8	1	1	11	no	no	no	no	3	2	2	—
9	0	0	—	no	yes	yes	no	4	3	1	—
10	0	0	—	no	yes	yes	no	5	4	2	1
11	0	0	—	no	—	yes	—	6	5	3	2
12	0	0	—	no	—	yes	next shift pulse yes	7	6	4	3
								x	7	6	5

identical counters provides for comparing adjacent scans for identity. The counters hold the input information until they are reset by reset pulse P_r , which is electronically switched through gates G_s once each scan alternately to reset both B counters and both A counters.

The comparison is accomplished in gates G_s once each scan after the counters have received their input information and at a time determined by the comparison pulse P_c . One of the six comparison gates will respond only when the input data P_i and P_{i+1} have remained constant from one scan to the next.

Scan-to-scan identity in the long-black counter allows the comparison pulse to appear at the output of buffer B_{di} . Scan-to-scan identity in the total-pulse counter allows the comparison pulse to appear in the

output of buffer stage B_{di} . A pulse appears at the output of both of the buffer stages only when scan-to-scan identity is indicated by both the total-pulse and the long-black counters. This is the necessary condition to pass the signal through gate G_s to the identity-gate generator.

After the A and B counters have been compared for identity they are read out by read-out pulse P_{ro} . If there has been no identity the read-out pulse appears at the output of gate G_n . The electronic switch then allows the read-out pulse to appear alternately at the input of the G_s gates. It enables the outputs of either the A or the B counters to appear at the outputs of the appropriate G_i gates.

The B_i buffers then show the accumulated count per scan inde-

pendently of whether the counts appear in the A counters or the B counters. The first scan of the character is detected in buffer B_s and used to generate an inhibiting signal whose duration is $1\frac{1}{2}$ scan periods. This inhibiting signal, applied to gate G_s , prevents the recognition of an identity on the first two scans of the character. Subsequent scans of the character are prevented from generating additional inhibiting gates by the $1\frac{1}{2}$ -character-period gate generator applied to gate G_i to disable it for the duration of the number.

Coding

The coded combination (Table I) of total-pulse and long-black counters is formed by the G_m gates. Only one or none of these five combinations can appear during one scan. The prime combinations are obtained in the B_m buffers.

The instruction to put into storage is accomplished implicitly whenever a signal appears on one of the five code-combination lines. The storage register is shifted or advanced by the system trigger P_s , when the trigger is enabled to appear at the output of gate G_n . System trigger P_s appears and the register is enabled to advance when a permissive signal appears on either one of the two inputs to the B_n buffer. One input is connected to the identity-gate generator and allows the register to shift unless there is an identity.

Between characters, the outputs of both the total-pulse counter and the long-black counter are zero. This combination of 00 is not sensed for identity in the G_s gates; therefore no identity signal can be generated. Also, since the code combination 00 has not been

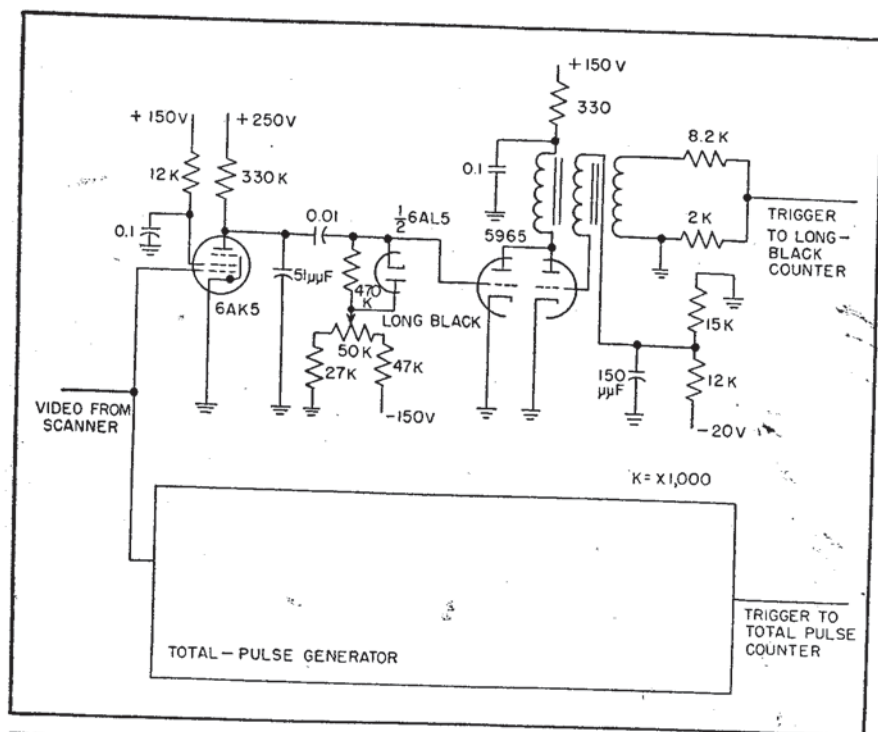

FIG. 4—Long-black pulse generator is pulse-width detector

formed in the G_m gates, there is nothing to put into storage.

Readiness for interrogation is detected in buffer B , which is connected to the seventh and last stage of storage. The first signal at the output of B , passes through gate G , and generates a gate whose duration is $1\frac{1}{2}$ scan periods. This gate connected to B_n enables the register to advance on the next system trigger.

Subsequent signals at the output of B , during the character storage time are prevented from passing through gate G , by the $1\frac{1}{2}$ -character-period gate generator, the latter

being energized by the system trigger that occurs after the first output signal at B_n . This particular system trigger is broadened in the matrix interrogation-pulse generator and is then used in the diode matrix.

Shift Register Storage

Each block in Fig. 6A represents one magnetic core. There are thirty-five cores arranged in five columns of seven each. Each of the five columns is used to store one of the five discrete code combinations.

Information is always read into row 1 and remains in row 1 until

a shift signal is applied whereupon the content of row 1 is advanced to row 2.

Access to the information in the cores is available only during the shift-pulse time. As indicated in Fig. 6A, a single shift signal suffices to advance all thirty-five cores.

Figure 6B shows the scanned character THREE. The total number of pulses T in scan one is one. There are no long pulses L (code 10). For scan two: $T = 2, L = 0$ for code 20. Scans three, four and five also yield code 20. In scans six and seven, $T = 3, L = 0$ for code 30. Scan eight contains only one long pulse

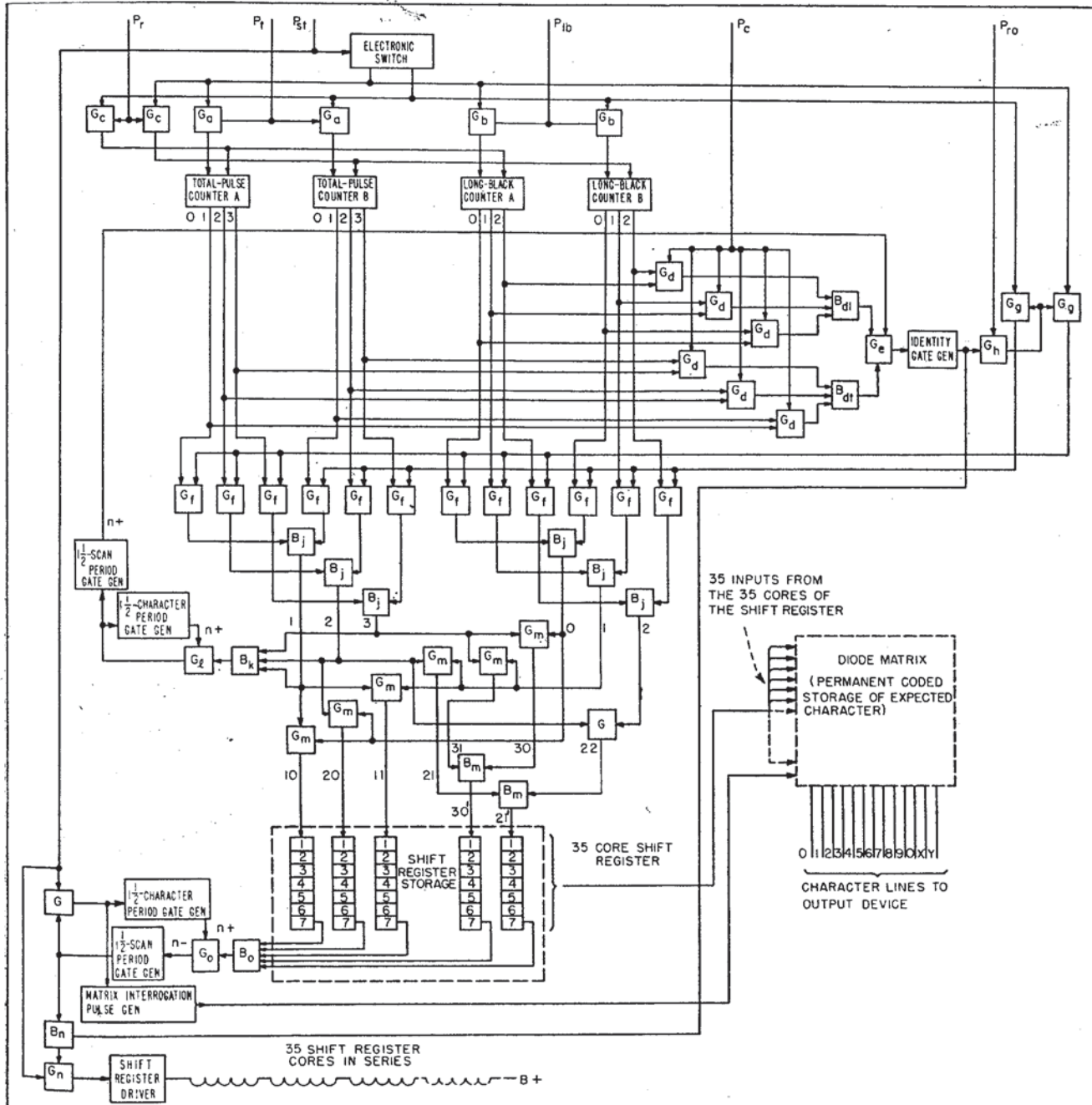

Explore Litigation Insights

Docket Alarm provides insights to develop a more informed litigation strategy and the peace of mind of knowing you're on top of things.

Real-Time Litigation Alerts



Keep your litigation team up-to-date with **real-time alerts** and advanced team management tools built for the enterprise, all while greatly reducing PACER spend.

Our comprehensive service means we can handle Federal, State, and Administrative courts across the country.

Advanced Docket Research



With over 230 million records, Docket Alarm's cloud-native docket research platform finds what other services can't. Coverage includes Federal, State, plus PTAB, TTAB, ITC and NLRB decisions, all in one place.

Identify arguments that have been successful in the past with full text, pinpoint searching. Link to case law cited within any court document via Fastcase.

Analytics At Your Fingertips



Learn what happened the last time a particular judge, opposing counsel or company faced cases similar to yours.

Advanced out-of-the-box PTAB and TTAB analytics are always at your fingertips.

API

Docket Alarm offers a powerful API (application programming interface) to developers that want to integrate case filings into their apps.

LAW FIRMS

Build custom dashboards for your attorneys and clients with live data direct from the court.

Automate many repetitive legal tasks like conflict checks, document management, and marketing.

FINANCIAL INSTITUTIONS

Litigation and bankruptcy checks for companies and debtors.

E-DISCOVERY AND LEGAL VENDORS

Sync your system to PACER to automate legal marketing.