

# The Metabolic & Molecular Bases of Inherited Disease

eighth edition

VOLUME III

EDITORS

Charles R. Scriver, M.D.C.M.  
Arthur L. Beaudet, M.D.  
William S. Sly, M.D.  
David Valle, M.D.

ASSOCIATE EDITORS

Barton Childs, M.D.  
Kenneth W. Kinzler, Ph.D.  
Bert Vogelstein, M.D.

McGraw-Hill  
Medical Publishing Division

New York St. Louis San Francisco Auckland Bogotá Caracas Lisbon London Madrid Mexico City  
Milan Montreal New Delhi San Juan Singapore Sydney Tokyo Toronto

M



**The Metabolic and Molecular Bases of Inherited Disease, 8th Edition**

Copyright © 2001, 1995, 1989, 1983, 1978, 1972, 1966, 1960 by The McGraw-Hill Companies, Inc. Formerly published as *The Metabolic Basis of Inherited Disease*. All rights reserved. Printed in the United States of America. Except as permitted under the United States Copyright Act of 1976, no part of this publication may be reproduced or distributed in any form or by any means, or stored in a database or retrieval system, without the prior written permission of the publisher.

1234567890 KGPKGP 09876543210

ISBNs

- 0-07-913035-6
- 0-07-136319-X (vol. 1)
- 0-07-136320-3 (vol. 2)
- 0-07-136321-1 (vol. 3)
- 0-07-136322-X (vol. 4)

This book was set in Times Roman by Progressive Information Technologies, Inc. The editors were Martin J. Wonsiewicz, Susan R. Noujaim, and Peter J. Boyle; the production supervisor was Richard Ruzicka; the text designer was José R. Fonfrias; the cover designer was Elizabeth Schmitz; Barbara Littlewood prepared the index. Quebecor Printing/Kingsport was printer and binder. This book is printed on acid-free paper.

**Library of Congress Cataloging-in-Publication Data**

The metabolic and molecular bases of inherited disease / editors,  
Charles R. Scriver ... [et al.].—8th ed.  
p.; cm.  
Includes bibliographical references and index.  
ISBN 0-07-913035-6 (set)  
1. Metabolism, Inborn errors of 2. Medical genetics. 3. Pathology, Molecular. I.  
Scriver, Charles R.  
[DNLM: 1. Hereditary Diseases. 2. Metabolic Diseases. 3. Metabolism, Inborn Errors.  
WD 200 M5865 2001]  
RC627.8 . M47 2001  
616'.042—dc21

00-060957

INTERNATIONAL EDITION

- ISBNs 0-07-116336-0
- 0-07-118833-9 (vol. 1)
- 0-07-118834-7 (vol. 2)
- 0-07-118835-5 (vol. 3)
- 0-07-118836-3 (vol. 4)

Copyright © 2001. Exclusive rights by The McGraw-Hill Companies, Inc. for manufacture and export. This book cannot be exported from the country to which it is consigned by McGraw-Hill. The International Edition is not available in North America.

# Lysinuric Protein Intolerance and Other Cationic Aminoacidurias

Olli Simell

1. Membrane transport of cationic amino acids lysine, arginine, and ornithine is abnormal in four disease entities: classic cystinuria; lysinuric protein intolerance (hyperdibasic aminoaciduria type 2, or familial protein intolerance); hyperdibasic aminoaciduria type 1; and isolated lysinuria (lysine malabsorption syndrome). Cystinuria, the most common of these, is dealt with in Chap. 191. About 100 patients with lysinuric protein intolerance (LPI) have been reported or are known to me. Almost half of them are from Finland, where the prevalence of this autosomal recessive disease is 1 in 60,000. Autosomal dominant hyperdibasic aminoaciduria type 1 has been described in 13 of 33 members in a French Canadian pedigree, and isolated lysinuria has been described in one Japanese patient.

Arginine and ornithine are intermediates in the urea cycle; lysine is an essential amino acid. In lysinuric protein intolerance (LPI) (MIM 222700), urinary excretion and clearance of all cationic amino acids, especially of lysine, are increased, and these amino acids are poorly absorbed from the intestine. Their plasma concentrations are low, and their body pools become depleted. The patients have periods of hyperammonemia caused by "functional" deficiency of ornithine, which provides the carbon skeleton of the urea cycle. Consequently, nausea and vomiting occur, and aversion to protein-rich food develops. The patients fail to thrive, and symptoms of protein malnutrition are further aggravated by lysine deficiency.

2. Patients with LPI are usually symptom-free when breast-fed but have vomiting and diarrhea after weaning. The appetite is poor, they fail to thrive, and if force-fed high-protein milk or formulas, they may go into coma. After infancy, they reject high-protein foods, grow poorly, and have enlarged liver and spleen, muscle hypotonia, and sparse hair. Osteoporosis is prominent, and fractures are not uncommon; bone age is delayed. The mental prognosis varies from normal development to moderate retardation; most patients are normal. Four patients have had psychotic periods. The final height in treated patients has been slightly subnormal or low-normal. Pregnancies are risky: Profound anemia develops, platelet count decreases, and severe hemorrhages during labor and a toxemic crisis have occurred, but the offspring are normal if not damaged by delivery-related complications. Acute exacerbations of

hyperammonemia have not been a frequent problem in treated patients, but may have been the cause of the sudden death in one adult male after moderate alcohol ingestion. About two thirds of the patients have interstitial changes in chest radiographs. Some patients have developed acute or chronic respiratory insufficiency, which in a few has led to fatal pulmonary alveolar proteinosis and to multiple organ dysfunction syndrome. Patients present with fatigue, cough, dyspnea during exercise, fever, and, rarely, hemoptysis, and may also show signs of nephritis and renal insufficiency. One adult patient with pulmonary symptoms has been treated with high-dose prednisolone and is in remission over 6 years after the occurrence of the symptoms. In another patient, bronchoalveolar lavages have produced immediate relief during several subacute exacerbations.

3. In LPI, the concentrations of the cationic amino acids in plasma are subnormal or low-normal, and the amounts of glutamine, alanine, serine, proline, citrulline, and glycine are increased. Lysine is excreted in urine in massive excess, and arginine and ornithine in moderate excess. Daily urine contains a mean amount of 4.13 mmol lysine (range 1.02 to 7.00), 0.36 mmol arginine (0.08 to 0.69) and 0.11 mmol ornithine (0.09 to 0.13) per 1.73 m<sup>2</sup> body surface area. The mean renal clearances are 25.7, 11.5, and 3.3 ml/min/1.73 m<sup>2</sup>, respectively; occasional values suggest net tubular secretion of lysine. Cystine excretion may be slightly increased. Blood ammonia and urinary orotic acid excretion are normal during fasting but are increased after protein meals. The serum urea level is low to normal, and lactate dehydrogenase, ferritin, and thyroid-binding globulin levels are elevated.

4. The transport abnormality is expressed in the kidney tubules, intestine, cultured fibroblasts, and probably in the hepatocytes, but not in mature erythrocytes. In vivo and in vitro studies of the handling of cationic amino acids in the intestine and kidney strongly suggest that the transport defect is localized at the basolateral (antiluminal) membrane of the epithelial cells. In vivo, plasma concentrations increase poorly after oral loading with the cationic amino acids, but also if lysine is given as a lysine-containing dipeptide. Dipeptides and other oligopeptides use a different transport mechanism not shared with that of free amino acids. The dipeptide thus crosses the luminal membrane normally, and is hydrolyzed to free amino acids in the cytoplasm of the enterocyte. An efflux defect at the basolateral membrane explains why the dipeptide-derived lysine is unable to enter the plasma compartment in LPI. Direct measurements and calculations of unidirectional

A list of standard abbreviations is located immediately preceding the index in each volume. Additional abbreviations used in this chapter include: HHH = hyperornithinemia-hyperammonemia-homocitrullinuria; LDH = lactate dehydrogenase; LPI = lysinuric protein intolerance; MCAT-1 and MCAT-2 = mouse cationic amino acid transporter-1 and transporter-2, respectively; TBG = thyroxine-binding globulin.



fluxes of lysine in intestinal biopsy specimens have confirmed that the defect indeed localizes to the basolateral cell surface. Similar cellular localization of the defect in the kidney tubules is suggested by infusions of citrulline, which cause not only citrullinuria but also significant argininuria and ornithinuria. Because citrulline and the cationic amino acids do not share transport mechanisms in the tubules, part of the citrulline is converted to arginine and then to ornithine in the tubule cells during reabsorption. A basolateral transport defect prohibits antiluminal efflux of arginine and ornithine, which accumulate and escape through the luminal membrane into the urine. The genetic mutations in LPI and possibly in all cationic aminoacidurias apparently lead to kinetic abnormalities in the transport protein(s) of the cationic amino acids. This is suggested by the fact that increasing the tubular load of a single cationic amino acid by intravenous infusion increases its tubular reabsorption, but reabsorption remains subnormal even at high loads. The other cationic amino acids are able to compete for the same transport site(s) also in LPI, but an increase in the load of one cationic amino acid frequently leads to net secretion of the others.

The plasma membrane of cultured fibroblasts shows a defect in the trans-stimulated efflux of the cationic amino acids; i.e., their flux out of the cell is not stimulated by cationic amino acids present on the outside of the cell as efficiently as it is in the control fibroblasts. The percent of trans-stimulation of homoarginine efflux in the fibroblasts of the heterozygotes is midway between that of the patients and the control subjects.

5. The exact cause of hyperammonemia in LPI remains unknown. The enzymes of the urea cycle have normal activities in the liver, and the brisk excretion of orotic acid during hyperammonemia supports the view that N-acetylglutamate and carbamyl phosphate are formed in sufficient quantities. Low plasma concentrations of arginine and ornithine suggest that the malfunctioning of the cycle is caused by a deficiency of intramitochondrial ornithine. This hypothesis is supported by experiments in which hyperammonemia after protein or amino nitrogen loading is prevented by intravenous infusion of arginine or ornithine. Citrulline, a third urea cycle intermediate, also abolishes hyperammonemia if given orally, because, as a neutral amino acid, it is well-absorbed from the intestine. Ornithine deficiency in LPI has recently been questioned because cationic amino acids and their nonmetabolized analogues accumulate in higher-than-normal amounts in intestinal biopsy specimens and cultured fibroblasts from LPI patients in vitro and the concentrations of the cationic amino acids in liver biopsy samples are similar or higher in the patients when compared to these concentrations in the control subjects. If hyperammonemia is not due to simple deficiency of ornithine, it could be caused by inhibition of the urea cycle enzymes by the intracellularly accumulated lysine; by a coexisting defect in the mitochondrial ornithine transport necessary for the function of the urea cycle; or by actual deficiency of ornithine in the cytoplasm caused by abnormal pooling of the cationic amino acids into some cell organelle(s), most likely lysosomes. The latter two explanations imply that the transport defect is expressed also in the organelle(s).
6. Lysine is present in practically all proteins, including collagen. Lysine deficiency may cause many of the features of the disease that are not corrected by prevention of hyperammonemia, including enlargement of the liver and spleen, poor growth and delayed bone age, and osteoporosis. Oral lysine supplements are poorly tolerated by the patients

because of their poor intestinal absorption. *ε-N*-acetyl-L-lysine, but not homocitrulline, efficiently increases plasma concentration of lysine in the patients, but acetyllysine or other neutral lysine analogues have not been used for supplementation.

7. Recently, a 622-amino-acid retroviral receptor (murine leukemia viral receptor REC1) with 12 to 14 potential membrane-spanning domains has been cloned. The physiological role of the receptor was soon found to be that of a cationic amino acid transporter at the cell membrane; the protein was hence renamed MCAT-1, mouse cationic amino acid transporter-1. The functional characteristics of the transporter are similar to those of system  $y^+$ , a widely expressed  $Na^+$ -independent transport system for cationic amino acids. The human counterpart of the mouse REC1 gene, encoding the retroviral receptor-transport protein, has been assigned to chromosome 13q12-q14 and named ATRC1. MCAT-1 (and  $y^+$ ) activity is not expressed in rodent liver, but two other related cationic amino acid transport proteins, formed presumably as a result of alternative splicing—Tea (T cell early activation; expressed also in activated T and B lymphocytes) and MCAT-2—are probably responsible for the low-affinity transport of cationic amino acids that is characteristic of (mouse) liver. Studies addressing the ATRC1 gene as well as the Tea and MCAT-2 genes as candidate genes for LPI are under way.
8. Treatment in lysinuric protein intolerance consists of protein restriction and supplementation with oral citrulline, 3 to 8 g daily during meals. Patients are encouraged to increase their protein intake modestly during citrulline supplementation, but aversion to protein in most patients effectively inhibits them from accepting more than the minimal requirement. The treatment clearly improves the growth and well-being of the patients. Pulmonary complications (interstitial pneumonia, pulmonary alveolar proteinosis, cholesterol granulomas, and respiratory insufficiency) have occasionally responded to early treatment with high-dose prednisolone, or to bronchoalveolar lavages. No therapy is known for the associated renal disease and renal failure.
9. The clinical and biochemical findings in other cationic aminoacidurias differ slightly from those in lysinuric protein intolerance. The symptoms of the index case with hyperdibasic aminoaciduria type 1 resemble those of LPI, but the other affected members of the pedigree are clinically healthy. The Japanese patient with isolated lysinuria has severe growth failure, seizures, and mental retardation. Her transport defect is apparently limited to lysine, and hyperammonemia is not a feature of the disease.

Perheentupa and Visakorpi described the first three patients with "familial protein intolerance with deficient transport of basic amino acids" in 1965.<sup>1</sup> The disease is now called lysinuric protein intolerance (LPI) (MIM 222700) or "hyperdibasic aminoaciduria type 2."<sup>2-5</sup> Over 100 patients with this autosomal recessive disease have been described or are known to me; 41 of them are Finns or Finnish Lapps.<sup>6-52</sup> The incidence in Finland is 1 in 60,000 births but varies considerably within the country.<sup>2,53</sup> Patients of black and white American, Japanese, Turkish, Moroccan, Arab, Jewish, Italian, French, Dutch, Irish, Norwegian, Swedish, and Russian origin have also been described. The fascinating combination in the disease of urea cycle failure, expressed as postprandial hyperammonemia, and a defect in the transport of the cationic amino acids lysine, arginine, and ornithine in the intestine and kidney tubules has led to extensive studies of the mechanisms that link these two phenomena. The mechanisms are still partly unresolved, and the sequence of events leading to hyperammonemia is unclear. We can simplify our knowledge by



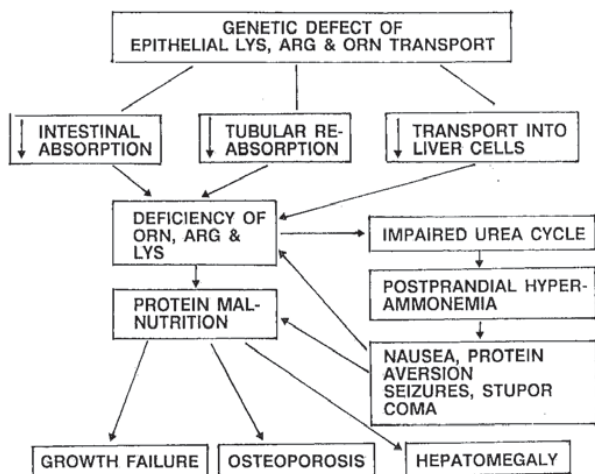

Fig. 192-1 The suggested pathogenesis of lysine, arginine, and ornithine deficiency, hyperammonemia, and aversion to protein in LPI.

saying that hyperammonemia is caused by “functional deficiency” of the urea cycle intermediates arginine and ornithine in the urea cycle<sup>4,11,14,54</sup> (Fig. 192-1). LPI has also been a productive model for studies of cellular transport: It is the first human disease where the transport defect has been localized to the basolateral (antiluminal) membrane of the epithelial cells.<sup>55–57</sup> Further, in LPI the parenchymal cells show a defect in the trans-stimulated efflux of the cationic amino acids, suggesting that the basolateral membrane of the epithelial cells and the plasma membrane of the parenchymal cells have analogous functions.<sup>58,59</sup>

Recently, the first candidate gene for LPI, *ATRC1*, encoding a human cationic amino acid transporter, has been mapped to the long arm of chromosome 13 (13q12-q14).<sup>60</sup> Without further proof, it is intriguing to hypothesize how a mutation in this or in a functionally similar gene or in genes encoding regulatory proteins of these transporters might lead to the membrane-selective cationic amino acid transport defect of LPI and to the complicated clinical features of the disease.

Several patients with variant forms of cationic aminoaciduria have been described in which the protein tolerance often is better than in LPI and the selectivity and severity of cationic aminoaciduria differs.<sup>23,25,33,61,62</sup> In the report by Whelan and Scriver<sup>61</sup> only the history of the index case suggested hyperammonemia, but other members of the pedigree have been symptom-free. The inheritance of this hyperdibasic aminoaciduria type 1 is autosomal dominant, implying that the patients are heterozygous for LPI or another type of hyperdibasic aminoaciduria.

## CLINICAL ASPECTS

### Lysinuric Protein Intolerance

**Natural Course of the Disease.** The gestation and delivery of infants with LPI has been uneventful.<sup>4–6,9–11,35</sup> Breast-fed infants usually thrive because of the low protein concentration in human milk, but symptoms of hyperammonemia may appear during the neonatal period and reflect exceptionally low protein tolerance or a high protein content in the breast milk. Nausea, vomiting, and mild diarrhea appear usually within 1 week of weaning or another increase in the protein content of the meals. Soy-based formulas are perhaps slightly better tolerated than cow’s milk. The infants are poor feeders, cease to thrive, and have marked muscular hypotonia. The patient’s liver and spleen are enlarged from the neonatal period onward. The association of episodes of vomiting with high protein feeds is not always apparent to the parents and may remain unnoticed even by trained physicians for years. Thus,

the diagnosis frequently has been delayed until the school age or even adulthood.<sup>35,47,63</sup>

Around the age of 1 year, most patients begin to reject cow’s milk, meat, fish, and eggs. The diet then mainly contains cereals cooked in water, potatoes, rice and vegetables, fruits and juices, bread, butter, and candies. The frequency of vomiting decreases on this diet, but accidental increases in protein intake lead to dizziness, nausea, and vomiting. A few patients have lapsed into coma, to the point where the EEG became isoelectric when the children were tube-fed with high-protein foods.<sup>27,35,40,41,47</sup> Enteral alimentation and total parenteral nutrition may cause symptoms in patients who have remained undiagnosed, because the protein or amino acid loads often exceed patient’s tolerance. Prolonged, moderately increased protein intake may lead to dizziness, psychotic periods, chronic abdominal pains, or suspicion of abdominal emergencies.

Bone fractures occur frequently, often after minor trauma.<sup>4,14,30,35,63–66</sup> In a Finnish series, 20 of 29 patients (69 percent) had suffered from fractures of the long bones or of compression fractures of the lumbar spine; 10 (34 percent) had had more than 2 fractures during the 18-year follow-up.<sup>63–65</sup> Most fractures occurred before the age of 5 years. Symptoms of osteoarthritis often begin at the age of 30 to 40 years. The radiologic signs of osteoporosis are usually severe before puberty but decrease with advancing age. The effect of citrulline therapy on osteoporosis is minimal.

Our accumulating experience with the late complications associated with the disease, together with recent reports of patients from outside Finland, suggest that in a sizable proportion of the patients the classic symptoms of protein intolerance may remain unnoticed. Instead, the patients may present with interstitial lung disease or respiratory insufficiency, or have renal glomerular or glomerulotubular disease with or without renal insufficiency as the first clinical finding (see “Complications and Autopsy Findings” below).

**Physical Findings.** Muscular hypotonia and hypotrophy are usually noticeable from early infancy but improve with advancing age.<sup>35</sup> Most patients are unable to perform prolonged physical exercises, but acute performance is relatively good. The body proportions of patients after the first couple of years of life are characteristic: the extremities are thin, but the front view of the body is squarelike with abundant centripetal subcutaneous fat. The hair is thin and sparse, the skin may be slightly hyperelastic, and the nails are normal. The liver is variably enlarged, and the spleen is often palpable and is large by ultrasound.

Patients who have remained undiagnosed until the age of several years have had characteristics typical of protein-calorie malnutrition and frequently resemble patients with advanced celiac disease. The subcutaneous fat may be reduced and the skin “loose” and “too large for the body” (Fig. 192-2).

The ocular fundi have been normal by ophthalmoscopy.<sup>35</sup> Of 20 patients studied, 14 had minute opacities in the anterior fetal Y suture of both lenses. In 10 patients, the opacities were surrounded by minute satellites. The opacities were never large enough to cause visual impairment and have remained stable, in some patients now for over 25 years. The mechanism underlying the lens abnormalities is unknown.<sup>67</sup>

The dentition of the patients has been normal, and the patients do not appear to be especially prone to caries, despite the high carbohydrate content of the diet.

**Growth.** Birth weights and lengths have been normal for gestational age, and postnatal growth is normal before weaning. The growth curves then begin to deviate progressively from the normal mean, and, at the time of diagnosis, 16 of 20 Finnish patients were more than 2 SD below the mean height, 12 patients were more than 3 SD, 6 patients more than 4 SD, 2 patients more than 5 SD, and 1 patient 6 SD below the mean.<sup>35</sup> Skeletal maturation is considerably delayed.<sup>63,64</sup> The bones usually mature



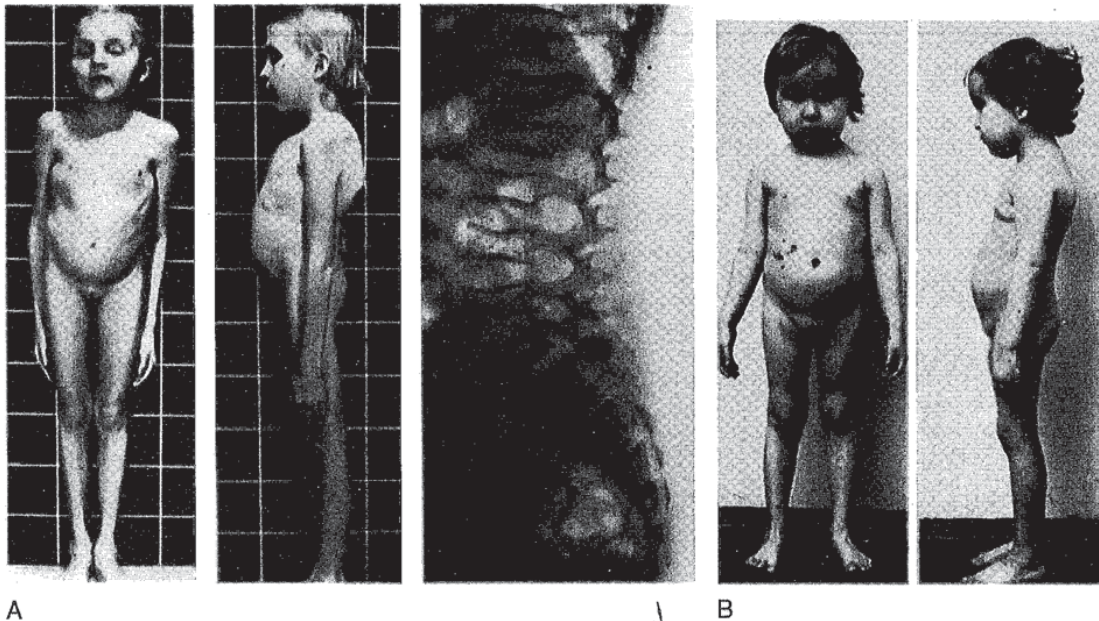

Fig. 192-2 Two children with LPI. The pictures were taken at the time of diagnosis. *A*, Child 12 years old. *B*, Child 6 years old. Note the prominent abdomen, hypotrophic muscles, and "loose" skin. The

thorax of the child in *A* is deformed and her trunk shortened because of osteoporosis and pathologic fractures of the vertebrae.

slowly and linearly without a pubertal catch-up spurt, and most patients have not reached skeletal maturity by the age of 20 years. The final height of the patients has almost invariably been closer to the normal than the height measured at the time of diagnosis, because of therapy and the late cessation of growth. The head circumferences have been normal for age.

The body proportions are normal, but with advancing age the moderate centripetal obesity, which is present from early childhood, becomes more obvious.

**Skeletal Manifestations and Bone Metabolism.** Osteoporosis is often recognizable in skeletal radiographs and has occasionally been the leading sign of LPI.<sup>30,63-65</sup> Two-thirds of the patients have had fractures, half of which have occurred after insignificant trauma. All fractures have healed properly within a normal time. The skull and sella turcica have been normal in roentgenograms.

Over 70 percent of the patients have some skeletal abnormalities, either osteoporosis, deformations, or early osteoarthritis.<sup>63-65</sup> In radiographs of 29 Finnish patients, osteoporosis was present in 13; the cortices of the long bones were abnormally thin in 5; the vertebrae had endplate impressions in 8; metaphyses were rickets-like in 2; and cartilage showed early destruction in 3. The cortex of the metacarpal bones was characteristically thickened in 7.<sup>64</sup> Morphometric analyses of bone biopsy samples showed moderate to severe osteoporosis in eight of nine patients studied; trabecular bone and osteoid volume were markedly reduced.<sup>65</sup> After double-labeling of bones with tetracycline *in vivo*, barely identifiable single lines were detected, suggesting poor bone deposition; the findings resembled those in severe malnutrition.<sup>68-74</sup> The number of osteoblasts and osteoclasts was low, and the extent of osteoid along the bone surfaces was low or normal in all specimens studied.

Laboratory tests for evaluation of calcium and phosphate metabolism have given unremarkable results.<sup>35,63-65</sup> Serum calcium and phosphate concentration, urinary excretion of calcium and phosphate, serum magnesium, estradiol, testosterone, thyroid-stimulating hormone, cortisol, vitamin D metabolites [25-(OH)<sub>2</sub>-D, 1,25-(OH)<sub>2</sub>-D and 24,25-(OH)<sub>2</sub>-D], parathyroid hormone, calcitonin, and osteocalcin concentrations have all been within the reference range.

The daily urinary excretion of hydroxyproline is significantly increased during pubertal growth, but half of the adult patients also have supranormal excretion rates (mean of all adults  $212 \pm 103 \mu\text{mol}/\text{m}^2$ ; adult reference range, 60 to  $180 \mu\text{mol}/\text{m}^2$ ).<sup>65</sup> The serum hydroxyproline concentration is increased in almost all patients irrespective of age. Serum concentrations of the C-terminal propeptide of type I procollagen and of the N-terminal propeptide of type III procollagen have been normal in all pediatric patients, but the concentration of the latter increases during puberty and remains elevated in adult patients.

The incorporation of labeled hydroxyproline into collagen was significantly decreased in cultured LPI fibroblasts as compared with age-matched controls at the ages of 5, 14, and 30 years, but there was no difference at the age of 44 years.<sup>65</sup> Morphometry of the collagen fibrils in electron microscopy showed no differences between patients and controls.

**Liver Pathology.** In the youngest patients, the histologic findings in liver biopsy specimens have been normal, with only occasional fat droplets in the hepatocytes.<sup>8,35,63,75</sup> In older patients, delimited areas in periportal or central parts of the liver lobules contained hepatocytes with ample pale cytoplasm and small pyknotic nuclei. In these cells, the glycogen content is decreased, and glycogen appears in coarse particles. At the borders of the abnormal areas, many nuclei are ghostlike and have central inclusion bodies staining positively with periodic acid-Schiff. Cytoplasmic fat droplets occur especially in the periportal areas. Children who died of alveolar proteinosis with multiple organ dysfunction syndrome have mostly shown extensive fatty degeneration of the liver but minimal or moderate cirrhosis. Inflammatory cells have always been absent in the liver biopsy samples.

Liver changes in LPI may reflect generalized protein malnutrition, because in kwashiorkor liver fat synthesis is increased, apolipoprotein synthesis is decreased, and lipoprotein lipases are inhibited.<sup>76</sup> Similar liver changes have also been induced in rats by lysine and arginine deprivation.<sup>77</sup>

**Performance in Adult Life.** Mental development is normal in most subjects. Performance is decreased, particularly in patients with known histories of prolonged hyperammonemia. Altogether,



about 20 percent of the patients with LPI reported in the literature or otherwise known to me are mentally retarded. Convulsions are uncommon, but periods of stupor have occasionally been misinterpreted as psychomotor seizures.<sup>18</sup> Four patients have had psychotic periods, which have clearly been precipitated by prolonged moderate hyperammonemia.<sup>35</sup>

Neuropsychologic evaluation of the patients suggests that mathematical and other abstract skills are particularly vulnerable to hyperammonemia. Treatment with a low-protein diet and citrulline supplementation<sup>11,14,63</sup> (see "Treatment" below) has significantly improved the life quality of the patients. Episodes of vomiting and other signs of hyperammonemia have become a rare exception. The patients who underwent prolonged periods of hyperammonemia in early infancy and childhood and who appeared severely retarded at the first presentation have considerably and continuously improved their performance during therapy. All Finnish patients are now able to take care of the activities of daily life, and none of them is institutionalized. The most severely retarded patient, who had an IQ of 40 at the age of 12 years, lives now at the age of 40 in the custody of another family and is capable of taking care of her daily activities; she also works in a protected environment outside the home for a few hours a day and helps routinely in the household. She is talkative, happy, and socially active. At the other end of the spectrum, one patient has graduated from a medical school, works successfully as an internist, is married, and is a mother of one. Several other patients have also graduated from high school or other secondary schools and are permanently employed. The physical fitness of the patients is fair, but their capacity for prolonged heavy work and physical endurance is clearly limited. One patient worked as a construction worker in a building company for a few years, but found the job too heavy; another has been an active jogger for years and is capable of running 15 km without problems. The oldest patient in Finland is now 49 years of age and retired 7 years ago because of back problems. He is mentally and physically active and takes care of the household duties of a small farmhouse. A Finnish-born patient in Sweden is now 58 years old.<sup>16,21,29</sup> One male and seven female patients are married.

**Pregnancies of the Patients.** The seven married women have had fifteen pregnancies. One of the mothers was treated during the pregnancy only with protein restriction; the other received citrulline supplementation (8 to 14 pills containing 0.414 g L-citrulline daily during meals). Anemia (hemoglobin <8.5 g/dl) occurred in all, and the platelet count decreased to less than  $50 \times 10^3/\text{mm}^3$ . A severe hemorrhage complicated two deliveries in one patient. Another patient had severe toxemia in her second pregnancy. The blood pressure increased to crisis values and she had prolonged convulsions and unconsciousness, but she recovered totally. In a third patient, an ultrasound-guided amniotic fluid puncture led to a bleed and loss of the fetus at 35 gestational weeks. Despite the mothers' anemia and severely decreased platelet count, other pregnancies and deliveries have been uneventful.

Of the 14 living children born to the patients, 13 are well at the age of 0.5 to 14 years. One child, whose delivery was complicated by a severe maternal hemorrhage, has hemiplegia and slightly delayed mental development, and another one was late in learning to speak but has later developed well.

One male patient has a healthy son.

**Complications and Autopsy Findings.** Since the first description of LPI in 1965,<sup>1</sup> 4 children and 1 adult of the 39 known Finnish patients have died, and a few pediatric LPI patients have died in other countries. A Moroccan patient died with pulmonary symptoms and autopsy findings similar to those of the four Finnish children (see below),<sup>37</sup> and a Japanese patient has had long-lasting, slowly progressive interstitial changes in the lungs.<sup>36</sup> An American child with LPI presented with interstitial pneumonia at the age of 27 months and later died of pulmonary alveolar

proteinosis.<sup>38</sup> More recently, three Italian patients with severe interstitial lung disease have been described.<sup>51</sup> One of them died at the age of 18 months; two others had an accompanying renal glomerular or glomerulotubular disease. One Arab child had severe respiratory insufficiency as the presenting sign at the age of 11 years, and had had clubbing of the fingers for 5 years.<sup>52</sup> An open lung biopsy showed cholesterol casts surrounded by a granulomatous process and giant cells; there was a small amount of interstitial inflammation and a moderate degree of scarring. Electron microscopy demonstrated cholesterol casts around and within macrophages and within alveolar cells in the alveolar spaces, but no hemorrhage.

Two of the four Finnish children who died had another systemic disease in addition to LPI (SLE; hypothyreosis). In all four, the fatal courses began as acute or subacute respiratory insufficiency, which progressed to multiorgan failure;<sup>63,75,78-80</sup> the symptoms fulfilled the criteria of the multiple organ dysfunction syndrome.<sup>81,82</sup> Progressive fatigue, cough, and mild to high fever were typical, and some children had blood in the sputum.<sup>78-80</sup> Dyspnea with marked air hunger during minimal exercise developed. Hemoglobin and platelet values fell, and the values of serum ferritin and lactate dehydrogenase, which are high in normal circumstances in these patients, increased even further. The sedimentation rate was elevated. Arterial oxygen tension was decreased, and the children had a severe bleeding tendency. The severity of liver, kidney, and pancreas involvement in the multiorgan failure varied. The pulmonary symptoms lasted from 2 weeks to 6 months before death.

The radiologic findings during the acute phase were similar in all patients with a fatal course.<sup>78</sup> Diffuse, reticulonodular densities and, later, signs of rapidly progressing airspace disease appeared in the chest radiographs at the mean age of 5 years (range 1.2 to 10.2 years) (Fig. 192-3). Two children developed acute respiratory insufficiency 2 months after the first radiologic signs of lung involvement, but one patient had densities for over 2 years and another for 12 years before acute exacerbation.

In one patient, a lung biopsy specimen taken at the time of appearance of the reticulonodular densities showed pulmonary alveolar proteinosis (Fig. 192-3C). At autopsy, three of the patients showed pulmonary alveolar proteinosis, and one had pulmonary hemorrhage with cholesterol granulomas. The specimens showed accumulations of myelin-like multilamellar structures, simple vesicles, granules, amorphous material, and crystals in transmission electron microscopy (Fig. 192-4).<sup>79</sup> Samples from the patient with pulmonary cholesterol granulomas contained interstitial and intra-alveolar cholesterol crystals and some multilamellar structures. It is interesting that similar pulmonary cholesterol granulomas were described in the lung biopsy sample of the Saudi Arabian child from Israel.<sup>52</sup>

One adult patient developed acute respiratory insufficiency with cough, fever, dyspnea, and hemoptysis at the age of 23 years.<sup>78-80</sup> Chest radiographs showed interstitial densities and airspace disease. Pulmonary function tests showed minimal obstruction of the distal airways but normal diffusing capacity. Extensive microbiologic investigations showed no evidence of infection. An open lung biopsy specimen showed bronchiolitis obliterans with signs of interstitial pneumonia. Granulation tissue polyps obstructed bronchiolar lumina, alveolar septa were thickened, and the sample contained a number of infiltrating lymphocytes and macrophages as well as signs of alveolar hemorrhages; no vasculitis nor full-blown alveolar proteinosis were found. The cytocentrifuge preparation made from the lung biopsy specimen showed 57 percent macrophages, 15 percent neutrophils, and 26 percent lymphocytes of the total cell count. The T-helper to T-suppressor cell ratio was 0.81. Symptoms disappeared rapidly and radiologic findings normalized within two months during high-dose prednisolone treatment. Eight months later, the patient relapsed with hemoptysis, but he responded well again to an increased corticosteroid dose. Now, 5 years later, he is symptom-free; the results of pulmonary function tests,



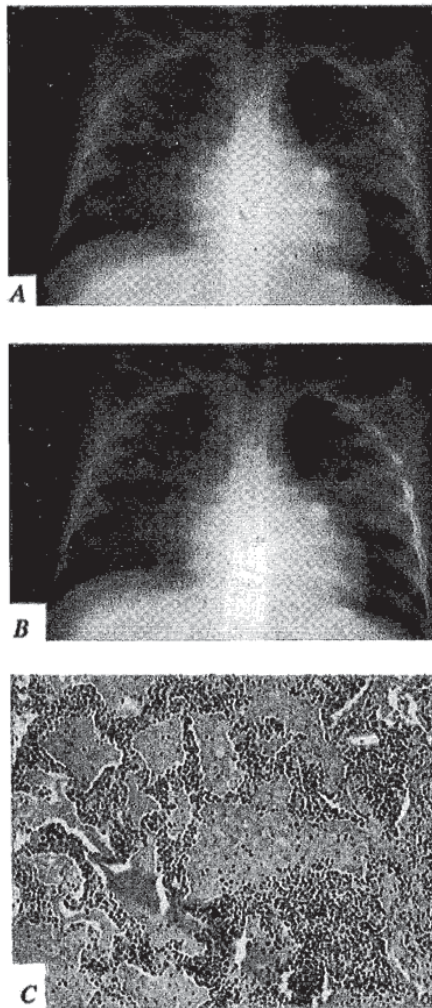
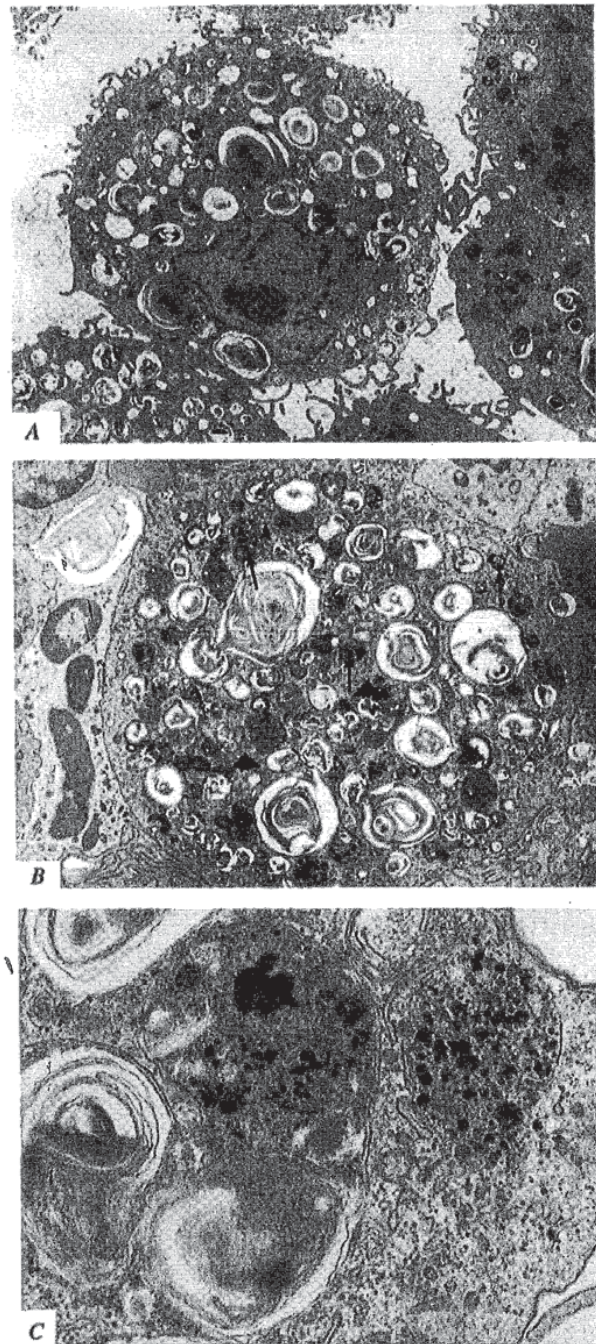

**Fig. 192-3** A 13-year-old girl with LPI who developed fatal respiratory insufficiency after a mild respiratory infection. **A**, Chest radiograph at the time of the first respiratory symptoms showed reticulonodular interstitial densities. **B**, Chest radiograph taken two weeks later shows interstitial and alveolar densities. **C**, Pulmonary biopsy specimen shows signs of alveolar proteinosis (hematoxylin-eosin, original magnification  $\times 115$ ). (From Parto et al.<sup>78</sup> Used by permission.)

high-resolution computed tomography, and radionuclide imaging are normal, but the proportion of erythrocytes in the bronchoalveolar lavage fluid is increased.

Another patient developed chronic, slowly progressive pulmonary insufficiency with dyspnea, cough, chest pain, and hypoxia at the age of 42 years.<sup>78-80</sup> A bronchoalveolar lavage cured clinical symptoms in hours, and the response has been as good in all of the six relapses that have occurred during the 7 years of follow-up. His chest radiographs show increasing interstitial linear and nodular densities. Six years after the initial symptoms, radionuclide perfusion imaging showed a segmental defect and uneven perfusion, and pulmonary function tests suggested slight restriction but normal diffusing capacity. Bronchoscopy showed signs of chronic bronchitis. The relative proportions of cells in the bronchoalveolar lavage fluid were normal.

It is interesting that one-third of the symptom-free patients studied (8 of 25) had findings in chest radiographs that suggested pulmonary fibrosis, and high-resolution computed tomography suggested pulmonary fibrosis in two-thirds of the patients studied



**Fig. 192-4** Pulmonary macrophages of patients with LPI. **A**, An electron micrograph shows macrophage containing multilamellar structures and electron-dense bodies that contain iron (magnification  $\times 3100$ ). **B**, The same cell at a greater magnification shows characteristic electron-dense areas which, according to the x-ray spectrum, contained mainly iron ( $\times 4600$ ). **C**, Another pulmonary macrophage containing a number of black-staining, iron-containing precipitations ( $\times 27,200$ ). (From Parto et al.<sup>79</sup> Used by permission.)

(8 of 14).<sup>78</sup> Most of the symptom-free patients (9 of 12) also showed mild abnormalities in perfusion imaging or in pulmonary function tests (8 of 12).

The total cell count in the bronchoalveolar lavage fluid of three adult LPI patients was normal, but two showed markedly increased lymphocyte and decreased macrophage percentages, suggesting



alveolar immunoactivation and subclinical alveolitis, as is common in many systemic diseases (Table 192-1).<sup>83</sup> Similar alterations have also been found in lavage fluid of patients with isolated pulmonary alveolar proteinosis.<sup>84</sup> Furthermore, the LPI lavage fluid also contained multilamellar structures of various sizes and shapes, which were absent in control samples. In one patient, the size of macrophages in the lavage fluid was markedly increased, but the size was normal in the others. Macrophages in all patients were filled with multilamellar structures similar to those in type II pneumocytes (Fig. 192-4). The estimated proportional volume of multilamellar structures in pulmonary macrophages was significantly increased, macrophages contained dense inclusions with iron-like material, and the iron content of the cells was elevated (Table 192-1).<sup>63,79</sup> Whether these changes in alveolar macrophages reflect altered iron or phospholipid metabolism in LPI or are a consequence of repeated subclinical pulmonary hemorrhages is unknown. It is possible that increased concentrations of cationic amino acids in the alveolar lining of LPI patients<sup>85,86</sup> may interfere with phospholipid metabolism, change the composition of the surfactant, and lead to the clinical symptoms. Because of their phagocytic nature, normal pulmonary macrophages contain a multitude of inclusions, including round, dense bodies, lamellae, myelin-like figures, and homogeneous lipid-like bodies.<sup>87,88</sup> Multilamellar structures closely resembling those of alveolar macrophages in LPI have been reported in pulmonary alveolar proteinosis associated with other diseases; in abnormalities of phospholipid metabolism; in a silica-induced animal model of alveolar proteinosis; and after experimental use of amphiphilic cationic drugs.<sup>88-91</sup>

Alveolar proteinosis is less common in children than in adults, but the course is usually more aggressive in childhood. Almost 60 pediatric patients with pulmonary alveolar proteinosis have been described, associated in some with alymphoplasia,<sup>92</sup> decreased IgA levels,<sup>93</sup> or various autoimmune diseases.<sup>94,95</sup> It is interesting that there are 10 pairs of siblings with alveolar proteinosis,<sup>93,96-102</sup> suggesting that genetic factors are important or that some of these patients with pulmonary alveolar proteinosis may also have had LPI.

It is apparent that the cascade leading to pulmonary alveolar proteinosis or cholesterol granulomas is part of the symptomatology of LPI. The pathophysiology remains unknown, but the abnormal content of cationic amino acids in the bronchoalveolar lavage fluid of these patients suggests that the transport of cationic amino acids may be abnormal also in the pulmonary alveolar epithelium (Table 192-1).<sup>63,85,86</sup> The transport defect might influence gas exchange or alter the production, composition, or function of surfactant in the alveoli. High-dose prednisolone treatment and bronchoalveolar lavages may slow or prevent disease progression if started early. Thus, all patients and their guardians should be warned of the symptoms.

Two of the patients who died had increased serum creatinine or decreased creatinine clearance values during exacerbation of the symptoms. At autopsy, kidney histology and immunohistochemistry unexpectedly showed immune-mediated glomerulonephritis in all four patients.<sup>63,75</sup> The disease was morphologically classified as diffuse, membranous or mesangial proliferative glomerulonephritis. Histologic findings were similar to those commonly seen in systemic lupus erythematosus. It is interesting that two patients also had onion-skin arteries in spleen tissue, another finding often associated with lupus. The glomeruli were hypercellular, the capillaries were narrowed, and the basement membranes were thickened. The tubules contained granular or homogenous periodic acid-Schiff (PAS)-positive material and, occasionally, calcium crystals. Indirect immunofluorescence studies revealed heavy membranous deposits of IgG, IgM, IgA, complement components C3 and C1q, and immunoglobulin  $\kappa$  and  $\lambda$  light chains in the glomeruli, and electron microscopy revealed large subepithelial and mesangial electron-dense deposits, proliferation of Bowman's epithelium, and tubuloreticular structures in the glomerular endothelial cells. The absence of linear deposition of IgG in

glomerular and pulmonary capillaries in all patients and the lack of anti-glomerular basement membrane (anti-GBM) antibodies in the only patient so studied excluded the anti-GBM disease.<sup>103</sup> Other diseases without anti-GBM antibody in which pulmonary hemorrhage and glomerulonephritis have occurred include SLE, Wegener granulomatosis, systemic necrotizing vasculitis, cryoglobulinemia, immune complex-mediated glomerulonephritis, and idiopathic crescentic glomerulonephritis with negative immunofluorescence.<sup>104-107</sup> The recent report by DiRocco and co-workers<sup>51</sup> confirms that renal glomerular involvement in LPI is not uncommon. In their patients, progression of the renal changes (as well as of the pulmonary changes) occurred despite treatment with high-dose prednisone. At this time, there is no known effective treatment of the renal glomerular disease in LPI.

The pediatric patients who died developed symptoms and signs of hepatic insufficiency in the terminal phase of their disease; the liver showed fatty degeneration and mild to severe cirrhosis at autopsy. Excessive amyloid was found in the lymph nodes and spleen. The pancreas showed acinar atrophy and fibrosis, resembling findings in kwashiorkor, and deficiency of cationic amino acids.<sup>77,108</sup> One patient at autopsy had pancreatic necrotizing inflammation, possibly due to shock, terminal pancreatitis,<sup>109</sup> or plugs in pancreatic ducts. However, the possible association of LPI with familial pancreatitis cases is intriguing, as some patients with familial pancreatitis excrete excessive lysine in the urine.<sup>110</sup> Bone marrow was hypercellular at autopsy, but the amount of megakaryocytes was decreased. None of the Finnish patients showed erythroautophagocytosis or erythroblastophagocytosis in the marrow.<sup>20,32,75</sup> Bone specimens showed osteoporosis.

Five adult Finnish patients (age 27 to 49 years) have developed arterial hypertension, and three have hypercholesterolemia (serum cholesterol >9.0 mM), which may represent heterozygous familial hypercholesterolemia. The one adult Finnish patient who died, died of a cause unrelated to the pulmonary disease.

**Other LPI-Associated Features.** A few patients with biochemical LPI have had uncommon associated features, which may point to heterogeneity of the syndrome or may be random associations; I have included these patients in the LPI group because of their biochemical identity. A mentally retarded boy with biochemical features typical of LPI showed a peculiar response to phenothiazines, which were prescribed to relieve his hyperactivity.<sup>33</sup> A Japanese 8-year-old girl had a prestage of systemic lupus erythematosus and showed multiple immunologic abnormalities, including impaired function of lymphocyte functioning and the presence of lupus erythematosus cells, antinuclear antibodies, and hypergammaglobulinemia.<sup>31</sup> Interestingly, also, one Finnish patient had systemic lupus erythematosus (see "Complications and Autopsy Findings" above), and another patient had antinuclear antibody-positive rheumatoid arthritis. Two Italian boys with LPI had striking joint hyperextensibility, and three had prominent autophagy of erythroblasts by granulocytes as well as clusters of degenerated erythroblast nuclei in the bone marrow;<sup>20,32,51</sup> autophagy was found also in a patient of Turkish ancestry.<sup>22</sup> The findings in the bone marrow aspirates are interesting and may be a common phenomenon in the disease, but were not found in several Finnish patients studied so far.<sup>35,63,75</sup> The autophagocytosis might be linked with abnormalities in the peripheral red cells of the patients.<sup>35,111</sup> Two Japanese patients with typical LPI findings also had decreased argininosuccinate synthase activity,<sup>45,50</sup> and one patient had glucose 6-phosphate dehydrogenase deficiency.<sup>49</sup>

#### Other Cationic Aminoacidurias

The proband described by Whelan and Scriver<sup>61</sup> has many clinical features of LPI, including recurrent vomiting during infancy, poor growth, and delayed bone age. The other affected members of the kindred with the dominantly inherited trait were also below the third percentile in height for normals individuals, but they were otherwise healthy. Whelan and Scriver discuss the possibility that

Table 192-1 Cell and Amino Acid Content of Bronchoalveolar Lavage Fluid in Four Adult Patients with Lysinuric Protein Intolerance and in Control Subjects

Case No.	Cell Count × 10 <sup>6</sup> /liter	Lymphs (%)	Baso (%)	Eos (%)	Polys (%)	Macroph (%)	Eryth (per view)	T <sub>H</sub> /T <sub>S</sub>	Total Amino Acid Concentration (μM)	Lysine/Total Amino Acids (μmol/μmol)	Arginine/Total Amino Acids (μmol/μmol)	Ornithine/Total Amino Acids (μmol/μmol)	Cross-Sectional Area of Macrophages (mean ± SD)	Volume of Multilamellar Structures/Macrophage Volume	Fe/Ci in Intramacrophage Inclusions
<b>Patients with LPI</b>															
1	77	6	0	3	0	89	>20	1.16	950	55.7	31.8	6.0	128.0 ± 39.9	0.27 ± 0.15	1.63 ± 0.95
2	205	46	1	0	1	52	10	0.96	667	11.7	7.8	3.6			
3	96	59	1	1	0	38	5	0.72	1088	60.8	25.7	9.8	215.4 ± 53.1	0.36 ± 0.10	2.88 ± 5.36
4*	237	3	0	0	0	97	0	1.80	1370	28.5	16.7	5.4	162.8 ± 40.1	0.36 ± 0.11	3.86 ± 2.30
4*	113	18	0	0	0	82	0	1.34	1122	67.6	43.9	4.4			
4*	178	22	0	2	5	71	0	0.65	728	7.8	13.9	5.8	166.0 ± 57.1	0.32 ± 0.18	2.79 ± 3.48
Mean									905	39.7	14.3	5.8			
<b>Control Subjects</b>															
1	821	77	0	0	7	16	0		1370	27.0	17.3	11.8	115.2 ± 32.5	0.09 ± 0.07	0.69 ± 0.98
2	70	5	0	3	3	78	0		761	9.1	0	4.6	112.3 ± 24.7	0.06 ± 0.06	0.27 ± 0.31
3	129	1	0	0	5	93	0		1231	15.4	5.9	5.8	160.3 ± 37.8	0.09 ± 0.05	0.19 ± 0.06
4	165	17	0	3	2	78	0		1232	27.7	15.9	7.2	168.1 ± 35.5	0.02 ± 0.03	0.40 ± 0.15
5	NT	16	0	0	3	81	0		867	10.1	7.2	4.0	138.6 ± 41.9	0.05 ± 0.06	0.48 ± 0.42
Mean									1092	17.9	9.3	6.7	141.1 ± 41.7	0.06 ± 0.06	0.41 ± 0.53

\*Bronchoalveolar lavage was performed on one patient with LPI on three separate occasions.

NOTE: NT = not tested; T<sub>H</sub> = helper T cells; T<sub>S</sub> = suppressor T cells.

SOURCE: From Parto<sup>63</sup> and Parto et al.<sup>78</sup> Used by permission.



the trait was a heterozygous manifestation of the LPI gene or of some other recessive transport disorder. It is interesting that the obligate heterozygotes in the pedigree of Kihara et al.<sup>33</sup> had urinary excretion values similar to those of the subjects with the dominant trait described by Whelan and Scriver,<sup>61</sup> suggesting that the index case might be homozygous for hyperdibasic aminoaciduria type 1. Further pedigrees with the trait of hyperdibasic-aminoaciduria type 1 are needed before firm conclusions concerning this relationship are possible.

In my opinion, the patients described by Kihara et al.,<sup>33</sup> Oyanagi et al.,<sup>24,25</sup> Brown et al.,<sup>23</sup> and others<sup>13,18,20,22,28</sup> have sufficient clinical and biochemical features to be regarded as patients with LPI. The only significant clinical differences are the less marked protein intolerance,<sup>25,28</sup> less significant growth failure,<sup>18,28</sup> and some peculiar features (see below).<sup>20,31-33</sup> We now know that clinical protein tolerance may vary also in LPI, and that vomiting and aversion to high-protein foods are not always prominent in confirmed patients. This variability may depend on the subject's capacity to handle waste nitrogen via other metabolic routes.<sup>112-120</sup> Omura and coworkers<sup>62</sup> described a Japanese 21-month-old girl with severe mental retardation, convulsions, marked growth failure, and clear signs of malnutrition. She excreted excessive lysine in the urine, "but arginine excretion was at the upper limit of normal while ornithine excretion was only slightly increased." Her intestinal absorption of lysine was decreased, but arginine, ornithine, and cystine absorption did not differ from that of control subjects. Fasting blood ammonia and values after loading with cow's milk were normal. LPI cannot with certainty be excluded in this patient, but she likely represents another mutation affecting the transport of the cationic amino

acids, and the disease should tentatively be regarded as an entity of its own, best called "isolated lysinuria."

## BIOCHEMICAL INVESTIGATIONS

### Plasma and Urine Amino Acids

Plasma and urinary amino acid concentrations and the renal clearances of plasma amino acids are given in Table 192-2. Plasma concentrations of lysine, arginine, and ornithine are typically one-third to one-half the normal means values, but occasionally may be well within the normal range.<sup>8,14,19,25,33,35,121</sup> The concentrations of serine, glycine, citrulline, proline, and, especially, alanine and glutamine are increased. The accumulation of amino nitrogen in these pools seems to be a regular feature of LPI. The increase in plasma citrulline is noteworthy.

Urinary excretion and renal clearance of lysine is massively increased, and that of arginine and ornithine is moderately increased. Because of the high plasma concentrations of serine, glycine, citrulline, proline, alanine, and glutamine, they are also found in excess in the urine, but their renal clearances are within the normal range.

In some patients, lysinuria and arginine-ornithinuria have been missed in the thin-layer or paper chromatograms used for screening of inborn errors of metabolism. The reason for the low excretion in these patients has always been that the plasma concentration of the cationic amino acids has been exceptionally low. In such a situation, the molar and relative excretion of the cationic amino acids can be minimal, even though the clearances are high. I have seen this phenomenon a few times in older,

**Table 192-2 Plasma Concentration, Urinary Excretion, and Renal Clearance of Free Amino Acids in Patients with Lysinuric Protein Intolerance\***

Amino Acid	Plasma Concentration, mM		Urinary excretion (mmol/24 h/1.73 m <sup>2</sup> )		Renal clearance (ml/min/1.73 m <sup>2</sup> )		
	Range in Normal Children†	Patients with LPI		Mean	Range	Mean	Range
		Mean	Range				
Alanine	0.173-0.305	0.772	0.417-1.017	1.068	0.465-1.586	0.953	0.698-1.324
α-amino-adipic acid	0.002	n.m.		0.609	0.405-0.821		
Arginine	0.023-0.086	0.027	0.012-0.058	0.356	0.076-0.687	11.508	3.175-22.300
Aspartic acid	0.004-0.023	n.m.		n.m.			n.m.
Asparagine and glutamine	0.057-0.467	5.583	3.644-7.161	6.491	4.365-8.542	0.891	0.595-1.628
Citrulline	0.012-0.055‡	0.232	0.141-0.530	0.519	0.155-0.988	1.440	0.762-2.425
Cystine	0.048-0.140‡	0.080	0.057-0.105	0.120	0.059-0.209	0.175	0.050-0.324
Glutamic acid	0.023-0.250	0.049	0.021-0.081	0.047	0.040-0.051	0.853	0.427-0.839
Glycine	0.117-0.223	0.467	0.385-0.530	2.058	1.595-2.808	3.062	2.538-4.067
Histidine	0.024-0.085	0.110	0.084-0.139	0.637	0.155-1.232	4.374	1.184-10.221
Isoleucine	0.028-0.084	0.059	0.029-0.082	0.099	0.071-0.158	1.306	0.598-2.076
Leucine	0.056-0.178	0.090	0.050-0.126	0.101	0.067-0.142	0.830	0.596-1.184
Lysine	0.071-0.151	0.070	0.032-0.179	4.126	1.022-7.000	25.655	11.116-45.877
Methionine	0.011-0.016	0.032	0.021-0.048	0.050	0.038-0.063	1.356	0.976-2.044
Ornithine	0.027-0.086	0.021	0.002-0.083	0.106	0.091-0.134	3.268	2.709-5.357
Phenylalanine	0.026-0.061	0.049	0.033-0.084	0.078	0.056-0.094	1.268	0.574-1.966
Proline	0.068-0.148	0.189	0.158-0.268	n.m.			n.m.
Serine	0.079-0.112	0.251	0.199-0.246	0.607	0.398-0.878	1.900	1.257-2.628
Threonine	0.042-0.095	0.113	0.030-0.172	0.277	0.111-0.554	1.825	1.235-2.578
Tyrosine	0.031-0.071	0.047	0.030-0.072	0.142	0.125-0.158	2.361	1.202-3.688
Valine	0.128-0.283	0.182	0.132-0.244	0.047	0.035-0.059	0.177	0.167-0.186

\*The plasma concentrations were measured after an overnight fast, and the respective 24-h urines were collected when the patients were on a self-chosen hospital diet. The clearance values are calculated from the 24-h urinary excretion and from the fasting plasma concentration. Plasma lysine, arginine, and ornithine concentrations were measured on 33 occasions in 20 patients; the other values are from four patients.

†From Dickenson et al.<sup>278</sup>

‡From Scriver and Davies<sup>279</sup>

NOTE: n.m. = not measurable

SOURCE: From Simell et al.<sup>35</sup> Used by permission.

undiagnosed patients who have spontaneously restricted their protein intake to the extreme, and who also have had clear signs of protein malnutrition. When protein intake has been increased, cationic aminoaciduria has become as prominent as in other patients.

The reabsorption defect in kidney tubules is most marked for lysine; arginine is less affected; and ornithine is absorbed best.<sup>121</sup> The measurements of tubular reabsorption of lysine have in some urine collections suggested net secretion. The reabsorption defect for arginine and ornithine and presumably for lysine remains significant also when plasma concentrations of these amino acids are increased, but at extremely high filtered loads, when plasma concentrations are several millimolar, the tubular reabsorption of arginine and ornithine reabsorption resembles normal. At these very high filtered loads, selective transport probably becomes unimportant and physical diffusion phenomena determine the rate of absorption. A significant increase in plasma concentration and, consequently, in the filtered load of one cationic amino acid leads easily to net tubular secretion of the other two cationic amino acids.

### Blood Ammonia, Urinary Orotic Acid Excretion, and Serum Urea

Blood ammonium concentration is normal (<70  $\mu\text{M}$ ) during fasting, but is elevated (100 to 560  $\mu\text{M}$ ) after regular meals.<sup>8,35</sup> The extent of postprandial hyperammonemia depends on the protein content of the meal. The ammonia values usually return to the normal range 2 to 6 h later. Frequent ingestion of high-protein foods, extensive fasting, acute infections (especially gastroenteritis), and severe physical or psychologic stress increase blood ammonia in the patients and easily cause persisting hyperammonemia, which does not disappear during fasting.

Urinary orotic acid is increased more frequently than blood ammonia, suggesting that orotic acid is a better indicator of urea cycle failure in these patients than hyperammonemia.<sup>13,46,122-125</sup> Urine samples collected during fasting frequently contain normal amounts of orotic acid (<0.03  $\mu\text{mol/kg/h}$ , or <11  $\mu\text{mol/mmol creatinine}$ ), but values are increased even during a self-chosen low-protein diet (geometric mean, 0.52; range 0.05 to 3.77  $\mu\text{mol/kg/h}$  in 24-h pooled urine samples) and increase massively if the protein intake is increased.<sup>122</sup> Nitrogen loads given in the form of cow's milk protein (0.5 g/kg), ammonium lactate (2.5 mmol/kg) or intravenous alanine (6.6 mmol/kg during 90 min) can be given without clinical risk to the patients. In healthy subjects, blood ammonia is stable after such loads, but blood ammonia and certainly urinary orotic acid excretion increase in the patients (geometric mean and range in the patients: 4.93; 1.61 to 11.19  $\mu\text{mol/kg/h}$  in 4- to 6-h pooled urine; 0.61; 0.10 to 7.22 in 1.5-h urine; and 3.32; 0.30 to 11.73 in 6-h urine after the three loads, respectively). Another advantage in orotic acid measurement is the stability of the compound: Urine samples can be sent via post at room temperature for orotic acid measurement, but blood ammonia has to be measured immediately.<sup>46,122</sup>

Serum urea concentration has been high-normal or even slightly elevated during the first few months of life, but later it has been consistently below the normal mean and often subnormal, the mean of 126 determinations in the patients being 3.7  $\mu\text{M}$  (range, 1.5 to 8.5  $\mu\text{M}$ ; normal, 2 to 7  $\mu\text{M}$ ).<sup>35</sup> Serum urea increases slowly after nitrogen loading in the patients.<sup>8,35</sup>

### Other Laboratory Tests

Slight normochromic or hypochromic anemia with anisocytosis and poikilocytosis is common.<sup>8,35,63,75,111</sup> Most patients have leukopenia, and the platelet count is decreased, in some young patients not uncommonly to less than  $30 \times 10^3/\text{m}^3$ . Reticulocyte count is often slightly elevated, and the osmotic resistance of the erythrocytes, the red cell indexes, and the serum iron level and iron binding capacity are normal. In some patients, autoerythrophagocytosis or erythroblastophagocytosis has been observed in the bone marrow,<sup>20,22,32,51</sup> and the number of megakaryocytes may be

increased; in one patient the marrow was hypoplastic with pathologic megaloblastic erythrocyte precursor forms, and in another the marrow was dyserythropoetic, suggesting ineffective erythropoiesis.<sup>75</sup> It is interesting that the changes in the peripheral blood cells decrease in intensity during and after puberty, and values in adults are usually within the range of healthy subjects.

The blood pH and the serum concentrations of sodium, potassium, chloride, calcium, and phosphate are normal. Serum low-density lipoprotein (LDL) and high-density lipoprotein (HDL) cholesterol values are often high in older children and adults, probably because the patients replace a large part of their protein calories by fat in the diet. In animals, high orotic acid concentrations influence lipoprotein metabolism,<sup>126</sup> but the possible link between orotic acidemia and hyperlipidemia in LPI is unclear. The triglycerides are usually slightly elevated in the patients. No constant abnormal peaks have been found in analyses of organic acids in the urine.

Interestingly, several of the patients with different ethnic backgrounds and all the Finnish patients have consistently had significantly increased concentrations of lactate dehydrogenase (LDH) and ferritin in serum.<sup>22,35,127</sup> All LDH isoenzymes, but most significantly the liver isoenzyme, are affected; the values are usually two to five times higher than the upper limit of normal. The LDH and ferritin values increase further during complications of the disease, including pulmonary alveolar proteinosis (see "Complications and Autopsy Findings" above). Thyroxine-binding globulin (TBG) is also elevated in the patients, and, consequently, measurements of total  $T_4$  give high values; free  $T_4$  is normal, and the patients are clinically euthyroid.<sup>34,35,128,129</sup> Whether there is a general increase in hormone carrier proteins or only a specific increase in TBG is not known.

In two Japanese patients, growth hormone responsiveness to glucagon, propranolol, arginine, and insulin was studied as a possible cause for the delayed growth and bone age of the patients.<sup>34</sup> The response to insulin was moderately decreased in the one patient studied before arginine supplementation was started, but all responses were normal when the patients had been on arginine supplementation for 8 months.

Kekomäki and coworkers<sup>130</sup> confirmed that the activities of the urea cycle enzymes in liver biopsy samples of the patients were normal. Glutaminase I activity, once suggested to be the basic defect in patients with LPI,<sup>16,21,29</sup> has since been proven to be normal in both leukocytes and liver.<sup>131</sup> Likewise, the activity of ornithine aminotransferase, the enzyme responsible for the main catabolic pathway of ornithine, has been normal or slightly elevated in the liver and cultured fibroblasts of the patients.<sup>57,132,133</sup> The concentration of *N*-acetylglutamine and the rate of its synthesis have not been measured in the patients, but the efficient production of orotic acid by the patients<sup>13,22,122,134</sup> strongly suggests that this cofactor and regulator of the carbamyl phosphate synthase activity<sup>135</sup> is available in sufficient quantities.

## PATHOPHYSIOLOGY

### Normal Cellular Transport of Cationic Amino Acids

In normal physiology, cationic and other amino acids reach the body only by passing through the intestinal wall in the process of absorption. They do this mainly as free amino acids but also partly as dipeptides and other small peptides, which then are hydrolyzed to free amino acids at the luminal brush border and, predominantly, in the cytoplasm of the epithelial cells.<sup>136-141</sup> During absorption, the amino acids first cross the luminal membrane of the epithelial cell. A fraction of the amino acids is used in cellular metabolism in the cytoplasm ("metabolic runoff"),<sup>142,143</sup> and the remainder must cross the basolateral (antiluminal) membrane of the cell to reach the body. In the cytoplasm, the amino acids may also enter the subcellular organelles (mitochondria, lysosomes, other vesicles, etc.), where some amino acids are metabolized. In



adult intestine, only free amino acids, not peptides, are able to cross the whole cell in absorption.

Absorption of the cationic amino acids lysine, arginine, and ornithine has been extensively studied in the kidneys, <sup>136,144-157</sup> intestine, <sup>158-160</sup> and some parenchymal tissues <sup>161-163</sup> of animals and human beings. Most studies have included cyst(e)ine, because in cystinuria the transport of all four amino acids is affected. <sup>148,158,164-179</sup> In the kidney, reabsorption occurs along the full length of the nephron. The proximal segment of the tubule receives the highest load of filtered amino acids and, consequently, has to absorb a significant load quickly and efficiently, whereas further down in the tubule a more selective reabsorption system would be more profitable. Such axial heterogeneity <sup>143,180</sup> in absorption has indeed been demonstrated for several amino acids, including the cationic amino acids. The net handling of the cationic amino acids in the kidney and their mutual interactions have been studied by administering amino acid loads and then measuring the urinary excretion and renal clearances of the amino acids. <sup>170,171,174,181-183</sup> Microperfusions of animal nephrons <sup>149,153,177,178</sup> and flux measurements in nephron segments or tubule fragments, <sup>149,150,166,184</sup> in renal cortical slices, <sup>148,151,152,166</sup> in cultured tubule-cells, <sup>185</sup> and in isolated vesicles prepared from the brush border <sup>146,155,172,186,187</sup> or basolateral cell membrane <sup>157</sup> have been performed. The transport of the cationic amino acids across the luminal membrane occurs via a shared,  $\text{Na}^+$ -dependent system. The system selective for the cationic amino acids in the proximal convoluted tubule has high capacity and low affinity, <sup>150</sup> whereas the system in the proximal straight segment has low capacity and high affinity and is shared with cystine. <sup>149</sup>

At the basolateral membrane in the kidney tubules, the transport of the cationic amino acids is not shared with cystine, and both high- and low-affinity systems are used. The transport from the cell to the pericellular space (efflux) occurs via  $\text{Na}^+$ -independent exchange diffusion, which may be shared with cystine on the cytoplasmic surface. <sup>143,157,166</sup>

At the brush border of the intestinal epithelium, the cationic amino acids are transported by a single  $\text{Na}^+$ -dependent system, which has high affinity and is shared by all cationic amino acids and cystine. <sup>188,189</sup>

White and Christensen <sup>162</sup> and others <sup>161,168,185,190</sup> have carefully characterized transport of cationic amino acids in cultured or isolated cells using human fibroblasts, <sup>161,168,191</sup> permanent hepatoma cell lines, rat hepatocytes, <sup>162</sup> and other cells. <sup>185,190</sup> Transport of cationic amino acid into human fibroblasts occurs by a saturable mediation, which they designated "system  $y^+$ " (earlier called  $\text{Ly}^+$ ). The system serves the flow of  $\omega$ -guanidino amino acids and  $\omega$ ,  $\alpha$ -diamino acids. The uptake of cationic substrates by system  $y^+$  is  $\text{Na}^+$ -independent, pH-insensitive, stereoselective, and inhibitable by neutral amino acids in the presence of  $\text{Na}^+$  ion. This system is not shared with cystine. <sup>164,168</sup> The uptake and efflux of the substrates are strongly stimulated by cationic amino acids inside and outside the cell, respectively. Arginine and homo-arginine accumulate in human fibroblasts and can reach distribution ratios of more than 20 at physiological external amino acid concentrations. <sup>161</sup> The driving force appears to be the transmembrane voltage.

In hepatoma cell lines, the transport of cationic amino acids occurs by the saturable mediation of the system  $y^+$ . <sup>162</sup> The influx into hepatoma cells has all the characteristics seen also in the system  $y^+$  of the fibroblasts, including strong stimulation by cationic amino acids inside the cell, that is *trans*-stimulation. In normal hepatocytes, no significant *trans*-stimulation was observed, suggesting that the  $y^+$  system is absent in these cells. The rate at which arginine is transported at the hepatocyte plasma membrane suggests that transport is the rate-limiting step in hydrolysis of arginine by arginase.

Recently, a more detailed analysis of amino acid transport at diverse cellular membranes has led to the discovery of at least three separate transport systems for the cationic amino acids.

Furthermore, direct studies of some cationic amino acid transport proteins has become possible after cloning of the respective genes (see "Genetics" below).

### Mutations in the Transport of Cationic Amino Acids

In a long series of studies, Segal and coworkers, <sup>176</sup> States and coworkers, <sup>185</sup> and others <sup>160,164,165,169-175,192</sup> have analyzed the interactions of the cationic amino acids and cystine in transport mutations, especially in the cystinuric kidney (see Chap. 191). Scriver and coworkers have provided a detailed review of current knowledge of the transport mutations in cystinuria and other cationic aminoacidurias. <sup>143</sup>

In classic cystinuria, reabsorption of cystine and the cationic amino acids in the kidney tubules is selectively impaired, occasionally to the extent that measurements show net tubular secretion of cystine or lysine. <sup>154,193</sup> In normal tubules, cystine, lysine, arginine, and ornithine mutually compete for transport. Intravenous loading studies in cystinuria suggest that the residual reclamation of cationic amino acids and cystine follows rules of competition similar to those in the normal tubules. <sup>169,174</sup> An absorption defect has also been found in the intestinal epithelium *in vivo* <sup>175</sup> and in biopsy samples of the jejunum. <sup>158,160</sup> Measurement of unidirectional and net fluxes of cationic amino acids in intestinal biopsy samples of patients with cystinuria clearly shows that the transport defect is localized at the luminal membrane of the epithelial cells. <sup>188</sup> Most likely, the efflux permeability of the luminal membrane is increased, but the influx is normal. <sup>189</sup>

Is the transport defect in patients with LPI similar to that in cystinuria? In their first report on LPI, Perheentupa and Visakorpi <sup>1</sup> had access only to semiquantitative measurement of plasma and urinary amino acids, and they regarded the urinary amino acid excretion as identical to that in cystinuria. It soon became apparent that cystine was excreted in significantly smaller quantities than in cystinuria, and Kekomäki and coworkers <sup>6,8</sup> suggested that the mechanisms of the transport defects differ in the two diseases. Absorption of the cationic amino acids by the kidneys <sup>10,15,25,121,156</sup> and small intestine <sup>9,23,24,33,55,194-196</sup> in LPI has later been carefully characterized. In both organs, absorption of lysine, arginine, and ornithine is defective. The slight increase in renal cystine losses could be explained by the excessive tubular lysine load and normal competition for absorption in the kidney tubules. Oral loading with the dipeptide lysylglycine increased plasma glycine concentrations properly, but plasma lysine remained almost unchanged in the patients <sup>55</sup> (Fig. 192-5). This was in striking contrast to the control subjects, in whom concentrations of both amino acids of the dipeptide increased in plasma. LPI was thus the first human disease in which a defect in peptide absorption was recognized. Because the transport of

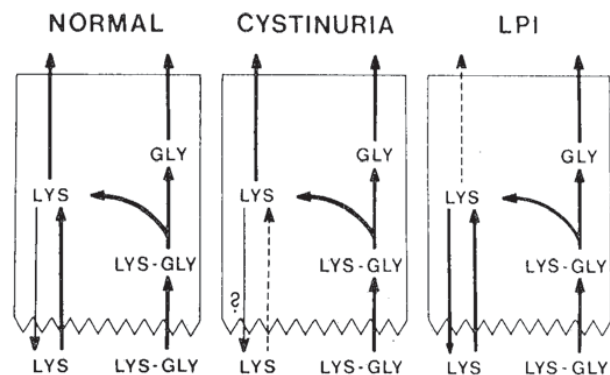

Fig. 192-5 Representation of brush border cells of jejunal mucosa, showing absorption of diamino acids (here lysine, in free and dipeptide form) and suggested sites of defect in cystinuria and LPI. Defective fluxes are indicated by dashed arrows. LYS = lysine. (From Rajantie et al. <sup>55</sup> Used by permission.)



oligopeptides is not shared with transport of free amino acids at the luminal membrane of the enterocyte, the lysine-containing dipeptide enters the cell normally in LPI. The absorbed peptides are hydrolyzed to free amino acids mainly in the cytoplasm of the enterocyte,<sup>137,138,197</sup> and they are able to cross the basolateral membrane only as free amino acids. The missing increase in plasma lysine after the lysylglycine load but normal increase in plasma glycine shows that the intracellularly released dipeptide-derived lysine is unable to cross the basolateral (antiluminal) membrane of the enterocyte and strongly suggests that the transport defect in LPI is localized at this membrane in the epithelial cells.

In vitro studies of unidirectional and net transport of cationic amino acids in jejunal biopsy samples of the patients soon proved even more directly that the transport defect is situated at the basolateral (antiluminal) membrane of the epithelial cell.<sup>57</sup> These in vitro results differed clearly from identical experiments in cystinuria,<sup>189</sup> where the abnormality in lysine transport was located at the luminal membrane, and the defect in cystine absorption could perhaps best be explained by increased efflux permeability at the luminal membrane of the epithelium. Interestingly, in an earlier study of cationic amino acid accumulation in jejunal biopsy samples and uptake during intestinal perfusion in LPI, no defects could be found.<sup>194</sup> This failure is understandable now, when the defect in LPI has been localized at the antiluminal membrane, and we know that the epithelial cells in LPI accumulate higher-than-normal concentrations of the cationic amino acids (see below).

Rajantie and coworkers<sup>56</sup> gave patients with LPI prolonged intravenous infusions of citrulline and measured plasma and urinary amino acids during the loading. Compared with controls, the plasma citrulline concentration of the patients increased normally, but urinary citrulline excretion increased excessively. Rises in plasma arginine and ornithine during the loading were subnormal, but massive argininuria and moderate ornithinuria appeared (Fig. 192-6). The excretion rates of lysine and other amino acids remained practically unaltered, thus excluding mutual competition as the cause for the increases. This finding is compatible with a transport defect at the basolateral membrane of the renal tubule cells and can be explained as follows: Citrulline as a neutral amino acid does not use the cationic amino acid transport system; citrulline is partly converted to arginine and further to ornithine in the tubule cell as an integral part of the

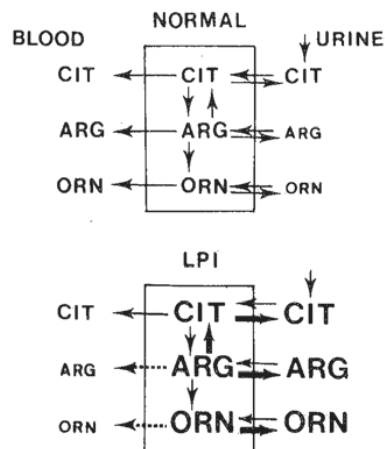

Fig. 192-6 Suggested mechanism of tubular reabsorption of citrulline in human beings and of the pathophysiology of the massive argininuria and moderate citrullinuria and ornithinuria in LPI. Bold type and arrows indicate increased concentrations and fluxes; thin type and dotted arrows indicate decreased concentrations and impaired fluxes. (From Rajantie et al.<sup>56</sup> Used by permission.)

Table 192-3 Steady State Amino Acid Concentrations in Intact Cultured Fibroblasts of a Control Subject and a Patient with Lysinuric Protein Intolerance

Amino Acid	Concentration Ratio	
	Control	LPI
Lysine/alanine	0.23 ± 0.007	0.35 ± 0.014
Ornithine/alanine	0.11 ± 0.009	0.19 ± 0.008
Arginine/alanine	0.40 ± 0.024	0.54 ± 0.012
Leucine/alanine	0.30 ± 0.016	0.31 ± 0.015

NOTE: Human skin fibroblasts were maintained in culture medium 24 h prior to harvest with a rubber policeman. Cells were resuspended in 1 ml phosphate-buffered saline, sonicated, and deproteinized. The supernatants were assayed for amino acid content with a Durrum D-500 amino acid analyzer. Values are the mean ± SEM,  $n = 4$ . Amino acid values were normalized to fibroblast alanine concentrations, which were  $18 \pm 1.3$  and  $17 \pm 1.2$  pmol/mg protein in control and LPI cells, respectively.

reabsorption process; in LPI, formed arginine and ornithine are unable to exit at the antiluminal membrane, their intracellular concentrations increase, and backflux (argininuria and ornithinuria) into the lumen occurs; high intracellular arginine and ornithine concentrations inhibit citrulline metabolism in the tubule cell; intracellular citrulline concentration increases, and leads to citrullinuria.

Reabsorption curves for arginine and ornithine have been produced in patients with LPI by increasing the plasma concentration of arginine or ornithine in a stepwise manner and simultaneously measuring tubular filtration rate and plasma concentration and urinary excretion of the two amino acids.<sup>121</sup> The curves were clearly below those of healthy control subjects at all loads except at values close to the tubular reabsorption maxima of the controls, where the patients' curves approached those of the control subjects. It is possible that at such filtered loads (at plasma concentrations of several millimolars), active transport plays a minor part, and physical factors regulate the amount of reabsorption. The extrarenal metabolic clearances of arginine and ornithine by tissues, calculated from the same infusion experiments, were significantly decreased in the patients.<sup>198</sup> This finding suggests that besides the defect in epithelial transport, transport in LPI is abnormal in other tissues as well.<sup>190</sup>

A direct proof of such an extraepithelial transport defect was obtained in studies of Smith and coworkers,<sup>58</sup> who investigated steady-state amino acid concentrations in intact fibroblasts (Table 192-3), and influx (Figs. 192-7 and 192-8), efflux, and transstimulation of the transport of lysine and other cationic amino acids and their nonmetabolized analogues<sup>199</sup> in cultured fibroblasts of the patients (Fig. 192-9). In *trans*-stimulation experiments, the amino acid in question, or another amino acid which uses the same transport system, is present on the other side of the membrane than the labeled amino acid studied. The influx at the plasma membrane was not different from controls in LPI; *trans*-stimulated efflux was. A defect in *trans*-stimulation was found also in fibroblasts of the heterozygotes with values about 50 percent of that in homozygotes suggesting gene-dosage effect (Fig. 192-10). The results also imply that the basolateral membrane of epithelial cells and the plasma membrane of parenchymal cells are functionally analogous at least in transport of cationic amino acids, but it may well be that this analogy is a general physiological principle. Vesicles prepared from LPI fibroblast plasma membranes failed to show a transport defect for cationic amino acids.<sup>200</sup> This finding possibly is explained by the fact that the preparation of the vesicles favored equally formation of inside-out and right-side-out vesicles. If both forms are present in equal quantities, and the defect is only expressed in efflux, the sum effect in the mixture of the vesicles will be the same as in controls.

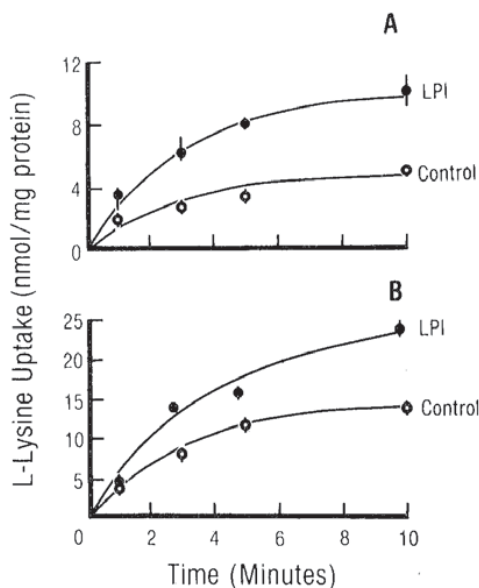

Fig. 192-7 L-Lysine uptake by cultured fibroblasts from a control subject (open circles) and a patient with LPI (solid circles). The cells were incubated for 90 min at 37°C in buffer without arginine (A) or in buffer containing 1 mM arginine (B), washed twice with PBS (37°C), and then incubated for 1, 3, 5, or 10 min at 37°C in PBS containing 0.1 mM L-[<sup>3</sup>H]lysine. Data are means and ranges of two or three measurements. (From Smith et al.<sup>58</sup> Used by permission.)

Smith and others<sup>201</sup> measured transport of the cationic amino acids and their nonmetabolized analogues in isolated erythrocytes of the patients. The mutant erythrocytes had identical transport characteristics with the controls, and the authors concluded that the mutant transporter is not expressed on the surface of mature human erythrocytes. The findings are in agreement with those of

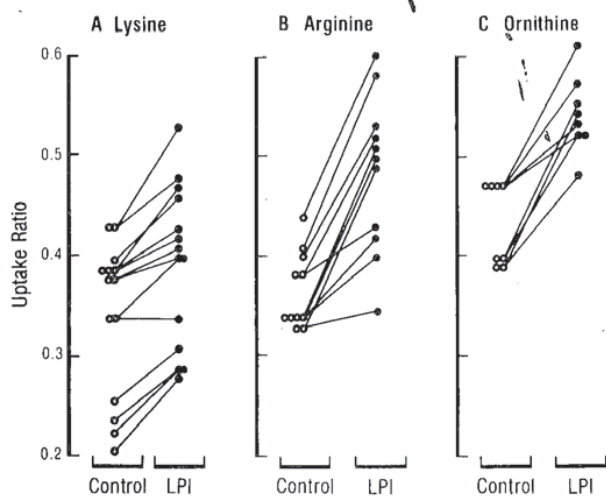

Fig. 192-8 Uptake ratios of the cationic amino acids versus L-leucine at steady state in cultured fibroblasts of control subjects and patients with lysinuric protein intolerance. The cells were incubated for 10 min at 37°C in PBS containing 0.1 mM L-[<sup>3</sup>H]leucine and (A) 0.1 mM L-[<sup>14</sup>C]lysine, (B) L-[<sup>14</sup>C]arginine, or (C) L-[<sup>14</sup>C]ornithine. Each point represents a single measurement of the net isotopic molar uptake ratio (cationic amino acid/leucine) in paired control and LPI cell strains. The differences between control and LPI cells for uptake of L-lysine ( $n = 13$ ,  $p < 0.02$ ), L-arginine ( $n = 16$ ,  $p < 0.01$ ), and L-ornithine ( $n = 8$ ,  $p < 0.01$ ) are significant by the Wilcoxon signed rank tests. (From Smith et al.<sup>58</sup> Used by permission.)

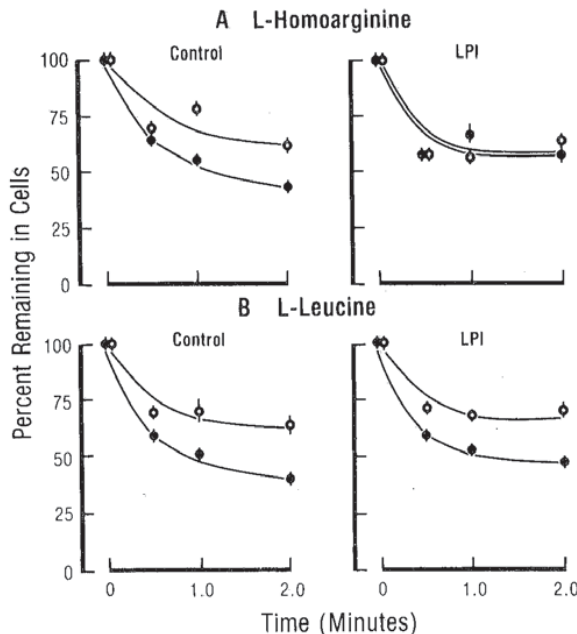

Fig. 192-9 Efflux of L-homoarginine from cultured skin fibroblasts of a control and LPI cell line. The cells were incubated for 40 min at 37°C in buffer containing (A) 0.1 mM L-[<sup>3</sup>H]homoarginine and (B) 0.1 mM L-[<sup>14</sup>C]leucine. The time course of efflux was measured into unlabeled incubation buffer (*trans*-zero condition, open circles) or into buffer containing 1 mM unlabeled amino acid (*trans*-stimulated condition, solid circles). Time course for efflux from the cellular pool is shown. Zero-time homoarginine content (100 percent value) was  $2.8 \pm 0.16$  (control) and  $2.9 \pm 0.29$  (LPI) nmol/mg protein; zero-time leucine content was  $8.5 \pm 0.37$  (control) and  $9.8 \pm 0.59$  (LPI) nmol/mg protein. The difference in the zero-time leucine content for LPI and control cells was not significant. Each point represents the mean and SEM of four determinations. (From Smith et al.<sup>58</sup> Used by permission.)

Gardner and Levy,<sup>202</sup> who noticed that the transport of dibasic amino acids in human erythrocytes is temperature-dependent, incapable of uphill transport, and not dependent on extracellular sodium or potassium concentrations or on energy derived from cellular metabolism. They further stated that lysine transport in human erythrocytes comprises two saturable, carrier-mediated processes operating in parallel: One is a high-affinity, low-capacity process that predominates at low lysine concentrations; the other is a low-affinity, high-capacity process that predominates at higher lysine concentrations. Further studies on cationic amino acid

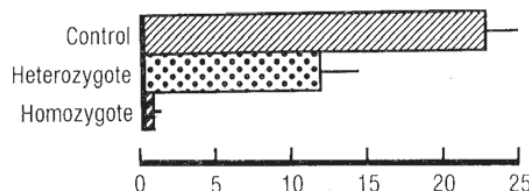

Fig. 192-10 Percent *trans*-stimulation of homoarginine efflux from cultured skin fibroblasts of control cells and cells from homozygotes and heterozygotes for LPI. The cells were preincubated for 40 min at 37°C in buffer containing 0.1 mM L-[<sup>3</sup>H]homoarginine and 0.1 mM L-[<sup>14</sup>C]leucine. The 1-min efflux of label was measured as described in Fig. 192-9. "*Trans*-stimulation" refers to the difference (increase) between *trans*-zero and *trans*-stimulated efflux, normalized to zero-time cellular isotope. Each value represents the mean of three or four determinations on one cell line; error bars indicate the range. (From Smith et al.<sup>58</sup> Used by permission.)



transport in rabbit reticulocytes<sup>203</sup> and human erythrocytes<sup>204</sup> have clarified details of the transport phenomena in these specialized cells.

### Subcellular Transport of Cationic Amino Acids

In the urea cycle, the urea molecule is assembled on an ornithine backbone; cleavage of the urea from arginine regenerates free ornithine. During the cycle, ornithine has to pass from the cytoplasm into the mitochondrial matrix to be carbamylated, and the formed citrulline has to be exported back to the cytoplasm to be further exposed by the enzyme argininosuccinic acid synthase. Whether or not mitochondrial transport processes are involved in the pathophysiology of LPI remains an open question.<sup>205</sup> In rat liver mitochondria and in mitochondria of human cultured fibroblasts, ornithine and citrulline transport has been relatively well characterized. In the classic study of Gamble and Lehninger,<sup>206</sup> the entry of ornithine into the mitochondria of rat liver was mediated by a carrier that was respiratory-dependent and required permeant proton-yielding anions for function.

Ornithine fluxes in mitochondria were earlier measured in the absence of active citrulline synthesis.<sup>207–218</sup> The study of Cohen and coworkers<sup>213</sup> avoided this pitfall: They analyzed the transport phenomena during and without citrulline synthesis in respiring rat liver mitochondria. They were able to characterize both influx of ornithine and efflux of citrulline in the mitochondria. When respiring mitochondria were preloaded with cold ornithine and then incubated in [<sup>3</sup>H]ornithine, the mitochondria produced citrulline of the same specific activity as that of external ornithine, but ornithine in mitochondrial matrix remained unlabeled. The concentration of ornithine in the matrix was also extremely low when the ornithine concentration in the incubation medium was less than 1 mM. Both findings imply that the ornithine molecule is not transported into the matrix randomly, but is channeled to the intramitochondrial enzymes for further processing to citrulline. The importance of ornithine catabolism by the matrix enzyme ornithine aminotransferase for the net movement of ornithine has remained unclear, but the activity in liver mitochondria is such that all ornithine not immediately used in the urea cycle is transaminated (see Chap. 85).

Studies of citrulline transport in rat liver mitochondria have suggested that the transport mechanisms do not depend on respiratory energy or the presence of permeant cations or anions.<sup>206,212,213</sup> Citrulline transport occurs in liver mitochondria but not in mitochondria of the heart.<sup>206</sup> Some studies have also implied that an ornithine-citrulline antiporter exists in the mitochondrial membrane,<sup>210</sup> but this finding may have been an artifact caused by experimental circumstances in which citrulline was not formed.<sup>211,213</sup>

Recently, increasing evidence has accumulated suggesting that mitochondrial ornithine transport is genetically altered in another human urea cycle disease, the hyperornithinemia-hyperammonemia-homocitrullinuria (HHH) syndrome.<sup>112,215,216,218–226</sup> (see Chap. 83). If the plasma membranes of cultured fibroblasts are made permeable to amino acids by digitonin, accumulation of labeled ornithine can be measured in the particulate fraction of the cells, which mainly contains mitochondria.<sup>223,224</sup> Such studies have suggested that ornithine accumulation in mitochondria is decreased in fibroblasts and liver of patients with the HHH syndrome.<sup>220,221,223,224,227</sup> If cultured HHH fibroblasts are incubated with labeled ornithine, a subnormal fraction of label is found in CO<sub>2</sub>, implying that ornithine is unable to enter the mitochondria to be further metabolized.<sup>215,216,218–221,225,227</sup>

A mitochondrial transport defect also has been proposed to have a part in the pathophysiology of LPI.<sup>205</sup> This theory has been based on biochemical results that speak against cytoplasmic ornithine deficiency in this disease. First, biopsy samples from the intestinal epithelium accumulate higher-than-normal concentrations of the cationic amino acids *in vitro*.<sup>57</sup> Second, LPI fibroblasts also accumulate higher-than-normal concentrations of cationic amino acids.<sup>58,59</sup> Third, direct measurements of concentrations

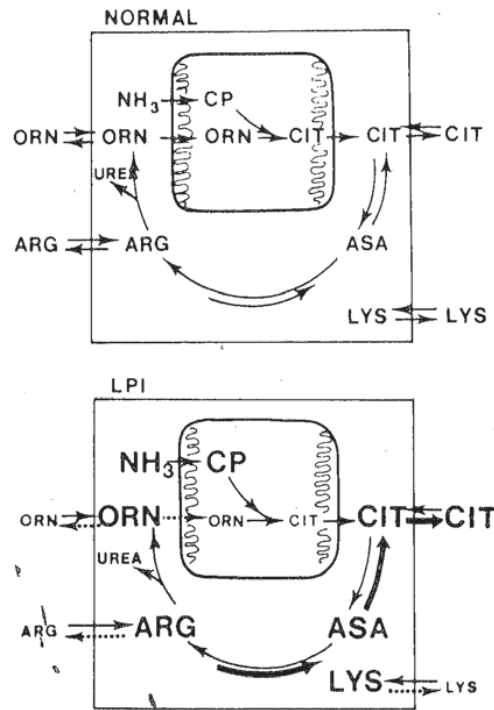

Fig. 192-11 Hypothetical mechanism of the elevated plasma citrulline concentration and the urea cycle failure in LPI. Bold type and arrows indicate supranormal concentrations and fluxes; thin type and dotted arrows, subnormal concentrations and impaired fluxes. For simplicity, only those fluxes are shown that are present at the "basolateral" and mitochondrial membranes of the liver cells. (From Rajantie *et al.*<sup>205</sup> Used by permission.)

of the cationic amino acids in liver biopsy samples of the patients contain normal or elevated concentrations of the cationic amino acids, even though their plasma concentrations are decreased.<sup>24,205</sup> Fourth, there is evidence that citrulline formation is not impaired: Plasma concentration of citrulline is constantly high-normal or elevated in the patients;<sup>8,30,31,34,35</sup> citrulline concentration is high-normal or increased in liver biopsy samples of the patients;<sup>24,205</sup> and the extrarenal metabolic clearance of citrulline and conversion of citrulline to arginine and ornithine are retarded<sup>54,205</sup> (Fig. 192-11).

These conflicting findings have been reconciled in a hypothesis which suggests that in LPI a defect in the efflux of the cationic amino acids exists at the plasma membrane of the liver cells or, if the cells retain polarity, at the basolateral membrane, and that the transport defect is expressed also in the mitochondria.<sup>205</sup> Such a mitochondrial defect would further increase cytoplasmic concentrations of arginine and ornithine. Depletion of ornithine in the mitochondria would lead to accumulation of carbamyl phosphate and to hyperammonemia. This theory, though interesting, has recently been questioned because the oxidation of ornithine in cultured LPI fibroblasts proceeds normally.<sup>59</sup>

System  $y^+$  for the cationic amino acids is expressed on the lysosomal membranes and used at least for influx of the cationic amino acids.<sup>228</sup> Normal lysosomes have active and selective efflux mechanisms for cystine, sialic acid, and probably other substances<sup>229–234</sup> (see Chap. 199). Efflux of other amino acids from the lysosomes is strictly limited as is suggested by the disruption of rat liver lysosomes if they are filled by passive diffusion with amino acid methyl esters.<sup>234</sup> These esters are hydrolyzed by lysosomal enzymes, but the liberated amino acids cannot readily escape from the lysosomes, possibly because of their high polarity. They accumulate in the lysosomes and may cause osmotic lysis of the organelles. In LPI, the lysosomes or other vesicular organelles



might function as a metabolically excluded pool of lysine and other cationic amino acids, so that the actual cytoplasmic lysine concentration would be relatively normal or even low. No direct proof of such a transport defect has been obtained, but the hypothesis is attractive.

### Malfunction of the Urea Cycle

Patients with LPI have decreased nitrogen tolerance and exhibit hyperammonemia after ingestion of even moderate amounts of protein.<sup>8,11,14,35,75,122</sup> The urea cycle failure is clearly less severe than in the "first" enzyme defects of the cycle, that is, in deficiencies of carbamyl phosphate synthase, ornithine transcarbamylase, and *N*-acetylglutamate synthase, or even in a deficiency of argininosuccinate synthase or lyase (see Chap. 85). The clinical impression is that the tendency to hyperammonemia in LPI closely resembles that seen in patients with the HHH syndrome.<sup>112,219,221–223,226</sup>

Already in the first description of the disease, Perheentupa and Visakorpi<sup>1</sup> noticed that intravenous infusion of ornithine during a loading with protein or intravenous L-alanine prevented the hyperammonemia that otherwise followed the loadings.<sup>1</sup> An identical effect has since been shown with arginine and citrulline when given intravenously.<sup>8,11,14,35,123,195</sup>

Oral supplementation with arginine and ornithine has been only minimally effective in these patients, because both amino acids are poorly absorbed from the intestine and easily produce diarrhea.<sup>10,57,196,235</sup> Obviously the absorption defect is not total because a low-protein diet and arginine or ornithine supplementation have improved growth and decreased hyperammonemia in patients with LPI.<sup>6–8,13,17,28,32,63</sup> A few variant patients tolerate arginine or ornithine supplementation well.<sup>13,17,28,32</sup> Awrich et al.<sup>14</sup> showed that the neutral amino acid citrulline, also an intermediate in the urea cycle, when taken as an oral supplement prevents hyperammonemia. It is well tolerated by LPI patients,<sup>11,30</sup> and its effect of preventing hyperammonemia in LPI has now been well documented.<sup>61,122</sup> As a neutral amino acid, it passes the cell membranes normally in LPI and is rapidly converted in the body to arginine and then to ornithine.

Poor intestinal absorption, excessive loss in the urine, and low plasma concentrations of the cationic amino acids arginine and ornithine strongly suggest that the malfunctioning of the urea cycle is caused by deficiencies of these urea cycle intermediates (Fig. 192-1). The finding that hyperammonemia produced by amino nitrogen or protein loads could effectively be prevented by simultaneous intravenous infusion of arginine or ornithine led to the hypothesis that the malfunctioning of the cycle was caused by a deficiency of ornithine in the liver cell.<sup>1,4,236</sup> Even now, when increasing evidence supports the view that the intracellular concentration of the cationic amino acids is increased in these patients in both epithelial and parenchymal cells,<sup>24,205</sup> the malfunction is best explained as a "functional deficiency" of the intermediates. In reality, it is possible that enzymes of the urea cycle are inhibited by an increased intracellular concentration of lysine (see Chap. 85) or that a transport defect at the inner mitochondrial membrane prevents the entry of ornithine into the mitochondria, just as hypothesized in the HHH syndrome (see Chap. 83). Such a defect would decrease the ornithine concentration in the mitochondrial matrix, decrease transcarbamylation, and slow urea production. It is also possible that cytoplasmic concentrations of the cationic amino acids actually are diminished because of accumulation of these substances in lysosomes or some other vesicular organelles. In such a case, cytoplasmic ornithine concentration could be temporarily increased by supplementation with arginine or ornithine. Similar genetic defects are known for transporters in lysosomal membranes (see Chap. 199). These defects all cause reduced efflux from the lysosomes; this is the case at least in cystinosis and Salla disease. An efflux defect could theoretically explain pooling and cytoplasmic depletion of the cationic amino acids in LPI, but our knowledge of amino acid movements into and out of the lysosomes is too sparse, and no

direct data to confirm the hypothesis of a lysosomal or vesicular efflux defect exist.

Half of the urea nitrogen originates as free ammonium, which enters the urea cycle by way of carbamyl phosphate synthesis, but this nitrogen does not gain access to the liver cell as free ammonium.<sup>237,238</sup> Animal experiments have suggested that the amide nitrogen of glutamine is an important precursor of urea nitrogen; glutamine functions as a transport and storage form of ammonium ion to keep its tissue levels within tolerable ranges via glutamine synthetase.<sup>16</sup> The ammonium for carbamyl phosphate synthesis is released from glutamine by intramitochondrial glutaminase, which was found to be defective in the leukocytes of one patient.<sup>16,21</sup> The suspected defect in glutaminase led to an interesting hypothesis of the mechanism of the transport disorder in LPI,<sup>16</sup> but later studies did not confirm the deficiency of glutaminase in leukocytes or liver biopsy samples of other patients.<sup>131</sup>

It is possible that during large nitrogen inflow—that is, after protein meals—intrahepatic glutamine synthesis serves to trap free ammonium and amino groups from other amino acids. Plasma glutamine is constantly high in LPI, and its fluctuations seem to be related to the previous nitrogen loading. Exact knowledge of the nitrogen flow in the liver during protein absorption is lacking, and the rate-limiting step in urea formation is not known. It may well be that the rate-limiting step varies and depends on several other factors, including the availability of the substrates.<sup>206,208,213,214,217,239–241</sup>

Patients with LPI efficiently produce orotic acid after nitrogen loading.<sup>22,46,122</sup> This cytoplasmic pathway could theoretically serve as a means to excrete excessive nitrogen from the body via carbamyl phosphate and aspartate, that is, the same substrates as in the urea cycle.<sup>242,243</sup> The level of renal clearance and urinary excretion of orotic acid is high, but the overall capacity of the pathway is limited, and only relatively small amounts of excess nitrogen can be excreted as orotate even during loading conditions.<sup>134</sup> It is interesting that uracil is also excreted in excess in LPI.<sup>22</sup>

### Lysine Deficiency

Despite prevention of hyperammonemia by citrulline supplementation and a low-protein diet, several features of the disease have remained unaltered in treated patients. Growth has not totally normalized, bone age is delayed, liver and spleen are enlarged, and liver pathology is unaltered.<sup>11,35</sup> The hematologic abnormalities have also persisted during therapy, osteoporosis persists, and the patients are prone to develop life-threatening pulmonary alveolar proteinosis or pulmonary cholesterol granulomas. These are possibly signs of a continuing deficiency of lysine, whose bioavailability is significantly reduced by the poor intestinal absorption and heavy renal losses.<sup>4,55,121,196</sup> In addition to the transport defects in the epithelial cells, which lead to poor net reclamation of lysine in the body, the transport defect at the plasma membrane of the parenchymal cells and the proposed transport defects in cell organelles also may contribute to the suspected lysine deficiency.<sup>58,205</sup>

Lysine is an integral part of practically all proteins. Relatively speaking, collagen is especially rich in lysine. The pathophysiological mechanisms of the often prominent osteoporosis in patients with LPI have remained uncertain.<sup>63–65</sup> It may well be that the osteoporosis is caused by lysine deficiency, which delays formation of the bone matrix and is an important factor in poor formation of other essential structural proteins and additional proteins.<sup>244–248</sup> Nothing is known of the acute or long-term effects of intravenous lysine infusions or oral supplementation with absorbable lysine derivatives in osteoporosis in LPI. Rajantie and coworkers found that *ε*-*N*-acetyllysine but not homocitrulline efficiently increases plasma lysine in patients with LPI.<sup>249</sup> Acetyllysine uses a transport system different from that of the cationic amino acids, making it suitable for oral use. Despite the apparently fast metabolism of acetyllysine to lysine in human



beings, its suitability for lysine replacement may be limited. In mice fed synthetic amino acid diets, replacement of L-lysine with  $\epsilon$ -N-methyl-L-lysine,  $\epsilon$ -N-dimethyl-L-lysine, or  $\epsilon$ -N-trimethyl-L-lysine resulted in relative replacement values of about  $\frac{1}{12}$ ,  $\frac{1}{20}$ , and  $\frac{1}{25}$ , respectively, of the value obtained with the standard lysine diet.<sup>250</sup>  $\alpha$ -N-acetyl-L-lysine was not used by mice, and the replacement value of the  $\epsilon$ -N-acetyllysine was about 3 percent that of lysine. Replacement of the charged  $\epsilon$ -amino group in lysine with a sulfur-containing group led to weight reduction. N-phosphorylated lysine has not been tested in this system.<sup>251</sup>

Arginine is an essential amino acid in inborn errors of the urea cycle and probably in growing children<sup>114,115</sup> and some animals, at least the cat.<sup>252,253</sup> However, arginine deficiency is unlikely to play a role in the symptoms in LPI because ample amounts of arginine should be available during citrulline supplementation.<sup>11,14,63,195</sup>

**Serum Ferritin, LDH, and TBG.** Serum concentrations of ferritin, LDH, and TBG have been consistently elevated in these patients.<sup>22,35,75</sup> The cause of the high concentration of ferritin is its decreased catabolism in the liver,<sup>111,127</sup> but the reason for this decrease is not known. High ferritin and LDH values have increased further during acute illnesses (see "Complications and Autopsy Findings" above). The increase in TBG and the associated increase in total T4 has in some occasions led to suspicion of hyperthyroidism in these patients.

## GENETICS

The inheritance of LPI follows a pattern typical for an autosomal recessive disease.<sup>2,53</sup> The incidence of the disease is 1 in 60,000 in Finland, but the birthplaces of the patients' grandparents are unevenly distributed in the country, and at least three large clusters of families can be recognized.<sup>2,4,35,53</sup> Most patients in other countries have been isolated cases<sup>13-15,18,19,22,23,27,28,30,31,33,44-46,48-52</sup> or multiple affected members of one family.<sup>17,20,25,26,32,34,47,51</sup>

Extensive functional studies have suggested that transport of amino acids into mammalian cells is mediated in different cell lines or tissues by a number of carrier proteins with differing characteristics.<sup>161-163,208,254-259</sup> Competition assays have shown that the cationic amino acids lysine, arginine, and ornithine share the same carrier(s), and that the kinetics of cationic amino acid uptake are similar in many tissues.<sup>161-163,258,260</sup> A widely expressed sodium-independent carrier system designated  $y^+$  has been extensively studied.<sup>161-163,258,260</sup> Another carrier, system  $b^{0,+}$  is also  $Na^+$ -independent and accepts both cationic and neutral amino acids.<sup>256,258</sup> Some mammalian cells express a third,  $Na^+$ -dependent transport process, designated  $B^{0,+}$ .<sup>257,258</sup> The degree to which each of these three systems is expressed varies widely among cell types.<sup>258</sup>

Recently, a cDNA encoding a retroviral receptor (murine leukemia viral receptor RECI) was cloned from NIH 3T3 fibroblasts by expression in human bladder carcinoma cells, which are normally resistant to the virus owing to absence of receptor.<sup>261</sup> The cDNA encoded a 622-amino-acid protein with 12 to 14 potential membrane-spanning domains. The extent of homology between the retroviral receptor and the arginine-histidine transporters of *Saccharomyces cerevisiae* (permeases CAN-1 and HIP-1)<sup>262-264</sup> raised the possibility that the physiological role of the receptor might be mediating cationic amino acid transport at the cell membrane.<sup>265,266</sup> Indeed, this hypothesis was confirmed by expression in *Xenopus* oocytes,<sup>265,266</sup> where the functional characteristics of the transporter were similar to those of the system  $y^+$ . Studies using northern blotting showed expression of mouse transporter RNA in a variety of tissues but not in the liver, again supporting the identity with system  $y^+$ .<sup>161,258</sup> This transport protein has now been renamed MCAT-1 (mouse cationic amino acid transporter-1) to better represent its physiological function.<sup>267</sup> Using mouse-human somatic cell hybrids, the human version of the mouse RBC-1 gene, ATRC1, was soon assigned to chromosome 13, and *in situ* hybridization localized the gene to 13q12-

q14.60 The locus shows restriction fragment length polymorphism with *TaqI*. Pairwise and multilocus linkage analyses have shown that the ATRC1 locus is close to the locus ATP1AL1 (ATPase,  $Na^+K^+$ ,  $\alpha$ -polypeptide-like 1) on one side and to the locus D13S6 on the other side.<sup>60</sup>

MCAT-1 is not expressed in freshly isolated rat hepatocytes or in normal rodent liver.<sup>162,258,259</sup> Furthermore, there are data suggesting that murine hepatocytes are resistant to ecotropic retrovirus infection, further suggesting that system  $y^+$  is not expressed in hepatic tissues.<sup>265,268</sup> However, the liver plays a central role in balancing the peripheral amino acid supply after and between meals, and the flux of amino acids between the liver and other tissues is determined, in part, by the activity of specific transport proteins. Recently, a cDNA was isolated from a murine T cell lymphoma cell line that encoded a protein related to MCAT-1, named Tea (T cell early activation).<sup>269</sup> Interestingly, the gene encoding Tea was expressed not only in activated T and B lymphocytes but also in liver. Hypothesizing that the Tea-encoded protein might be the hepatic cationic amino acid transporter, Cross and coworkers<sup>267</sup> found another cationic amino acid carrier (MCAT-2), which was closely related to Tea, was expressed in mouse liver, and had the same substrate specificity as the carrier in extrahepatic tissues. Furthermore, the MCAT-2 protein was encoded by the same gene as Tea, but differed in part of its sequence, presumably as a result of alternative splicing. Functional comparisons of the two transporters (the hepatic MCAT-2 and the more widely expressed MCAT-1 or  $y^+$ ) in *Xenopus* oocytes showed that, unlike in the extrahepatic transporter, arginine uptake mediated by the MCAT-2 transporter is significant only at substrate concentrations that exceed systemic levels in plasma; its function is also less dependent on the intracellular concentration of the cationic amino acids. Thus, the properties of MCAT-2 suggest that it is the low-affinity transporter of cationic amino acids known to be expressed in the rodent (and human)<sup>190</sup> liver. These properties enable hepatocytes expressing this carrier to remove excess cationic amino acids from the blood without interfering with their uptake by extrahepatic tissues.<sup>267</sup>

Cloning by expression in *Xenopus* oocytes has recently resulted in the isolation of kidney and intestine-specific cDNA clones called rat D2,<sup>270</sup> rat NAA-Tr,<sup>271</sup> and rabbit rBAT.<sup>272</sup> These clones have about 80 percent amino acid sequence identity and induce high-affinity uptake into *Xenopus* oocytes of a broad spectrum of amino acids including cystine, and dibasic and neutral amino acids. These transporters are type II membrane glycoproteins and exhibit similarity to  $\alpha$ -glucosidases and to 4F2 cell surface antigen heavy chain. The 4F2 protein also induces amino acid uptake into oocytes, but its substrate specificity is different.<sup>270,273-275</sup> It may well be that D2, rBAT, and the 4F2 heavy chain are not transporters as such but belong to a group of regulatory subunits of heterooligomeric transporters or are independent transport regulators.<sup>270,272-274</sup> Isolation of D2H, the human cDNA counterpart of the rat D2, from a human kidney library, and expression of D2H in *Xenopus* oocytes, showed that D2H induces uptake of cystine as well as dibasic and neutral amino acids. Furthermore, northern blot analysis demonstrated strong expression of D2H in human kidney and intestine. Mouse-human somatic cell hybrids showed that the human gene for D2H resides on chromosome 2.<sup>273</sup>

The genes for MCAT-1, MCAT-2, and the transporter regulatory units are strong candidate genes for the LPI mutation(s). Our increasing knowledge of the multiplicity and functional diversity of the cationic amino acid transporter proteins and transport regulatory proteins in mammalian tissues allows me to predict that the LPI phenotype will be split into subgroups based on different mutations in one or several transporters; furthermore, mutations in genes encoding transport regulatory proteins may also be involved in some families.

The hyperdibasic aminoaciduria type 1 described by Whelan and Scriver<sup>61</sup> showed autosomal dominant inheritance. Of the 33 subjects in the kindred, 13 had the trait. The suggestion that the affected members of the kindred are heterozygotes of an



autosomal recessive disease seems likely, even though no confirmed homozygotes are known. The possibility exists that the patient of Kihara et al.<sup>33</sup> is a homozygote for the trait, as has been suggested by Bergeron and Scriver,<sup>143</sup> but this remains a hypothesis. The original proposal by the authors that the carriers of the trait could be heterozygous for LPI is at least equally attractive.

The expression of the mutant gene in heterozygotes for LPI has been only partially characterized.<sup>2,53,58</sup> The constant finding of decreased epithelial transport of the cationic amino acids in the homozygotes and, especially, the direct measurement of defective cationic amino acid transport in cultured fibroblasts of homozygotes and heterozygotes for LPI,<sup>58</sup> strongly support the view that the mutation affects the transport protein at the basolateral cell membrane of the epithelial cells and at the plasma membrane of the parenchymal cells. Many LPI heterozygotes excrete slightly increased amounts of the cationic amino acids in the urine, but this has not been a constant finding.<sup>2,53</sup> The fact that the heterozygotes have not shown signs and symptoms of protein intolerance suggests that the urea cycle failure is a secondary consequence of the primary defect.<sup>276</sup>

## TREATMENT

Hyperammonemia, which occurs in the patients after high-protein meals, during prolonged fasting, or during severe infections, can now be effectively prevented and treated. A diet in which the protein content has been moderately decreased—in children, to 1.0 to 1.5 g/kg/day and, in adults, to 0.5 to 0.7 g/kg/day—forms the basis of successful treatment.<sup>11,14,35</sup> Acute symptoms disappear when the patients are on this diet, but, in many infants, severe protein aversion leads to minimal energy intake as well, and even though nausea and vomiting can be avoided, pediatric patients usually eat very poorly during the first years of life. Supplementation with arginine or ornithine has been moderately helpful in some patients,<sup>6–8,13,17,28,32</sup> but the decreased intestinal absorption of cationic amino acids limits their usefulness, and supplementation often leads to osmotic diarrhea.<sup>55,195,196</sup> Citrulline is a neutral amino acid and uses another transport mechanism at the cell membrane. It is readily absorbed from the intestine and converted to arginine and then to ornithine in the body, especially in the liver. Citrulline supplementation guarantees an adequate supply of urea cycle intermediates at the site of urea synthesis, and, indeed, oral citrulline supplementation has proved clinically to prevent hyperammonemia as efficiently as intravenous arginine or ornithine.<sup>11,14,122</sup> The dose of citrulline supplementation has been 2.5 to 8.5 g (14 to 48 mmol) daily, divided into three to five doses and taken with meals. The individual doses are first calculated according to the protein content of the meals and then adjusted according to the clinical and biochemical responses of the patients. Most patients quickly learn to know how much citrulline they need for a specific portion of each high-protein food. Citrulline can be given as powder dissolved in juice or as pills (ours have 0.414 g L-citrulline) or capsules.

In acute hyperammonemic crisis in LPI, the best treatment has been total removal of protein and nitrogen from the nutrition. Intravenous glucose should be given to supply as much energy as possible. In hyperammonemia, we have also infused ornithine, arginine, or citrulline intravenously, starting with a priming dose of 1 mmol/kg in 5 to 10 min and then infusing at a rate of about 0.5 to 1 mmol/kg/h until the symptoms have subsided. Sodium benzoate and sodium phenylacetate given intravenously or orally<sup>113,116,118,119</sup> appear clinically effective even though they only minimally correct alanine-induced hyperammonemia.<sup>134</sup>

Lysine has been given orally to these patients, but its intestinal absorption is poor and it causes diarrhea and abdominal pains.<sup>11</sup> A few patients have received lysine supplementation for longer periods, but the evidence that lysine can correct signs of protein malnutrition has not been convincing. It is interesting that acute loads of  $\epsilon$ -N-acetyllysine, a neutral analogue of lysine and a readily absorbed substance, increased plasma lysine concentra-

tions in the patients as well as in the control subjects.<sup>249</sup> Homocitrulline had no effect on plasma lysine. Because of the limited availability and high price of acetyllysine, it has not been used as a long-term supplement in patients.<sup>277</sup> Its usefulness as a replacement for lysine has recently been questioned.<sup>250</sup>

A potentially life-threatening complication of LPI is acute or chronic pulmonary involvement, which may present as interstitial changes on radiographs or as respiratory insufficiency and may progress to pulmonary alveolar proteinosis or cholesterol granulomas<sup>51,52,63,75,78–80</sup> (see “Complications and Autopsy Findings” above). Occasionally, lung involvement may be the presenting sign of the disease.<sup>38,51,52</sup> One adult patient with acute respiratory insufficiency was treated efficiently with high-dose prednisolone immediately after the onset of pulmonary symptoms; the symptoms subsided rapidly after initiation of the therapy. The dose was soon tapered, but a 2.5-mg intermittent-day dose was continued. A relapse 8 months later was again successfully treated by increasing the prednisolone dose. The patient received intermittent-day prednisolone for over 2 years, and has since been symptom-free for over 5 years. However, several pediatric deaths from pulmonary complications suggest either that it is necessary to start the treatment early, or that the response may be variable.<sup>51,52,75,80</sup> Indeed, in two Italian patients aged 5 and 24 years, treatment with prednisolone had no effect on the progression of the pulmonary changes, and the effect was minimal or absent also in an 11-year-old Arab girl.<sup>51,52</sup>

Glomerulonephritis and renal insufficiency, amyloid deposition in the spleen and lymph nodes, and occasionally severe fatty degeneration and cirrhosis of the liver appear to be not uncommon in association with the pulmonary symptoms of LPI; the potentially fatal syndrome fits the criteria of the multiple organ dysfunction syndrome.<sup>81,82</sup> Currently, I have no suggestions for specific treatment of this syndrome in patients with LPI.

## ACKNOWLEDGMENTS

This study was supported in part by grants from the Sigrid Juselius Foundation, the Academy of Finland, the Signe and Ane Gyllenberg Foundation, and the University Foundation, Turku, Finland. I am grateful to Dr. Katriina Parto, M.D., Dr. Ilkka Sipilä, M.D., Dr. Jukka Rajantie, M.D., Dr. Martti Kekomäki, M.D., and Prof. Jaakko Perheentupa, M.D., for collaboration, fruitful discussions and help in treating the Finnish patients during a quarter of a century. I want to thank Mrs. Marja Piippo, Mrs. Anneli Enlund, and my wife, Tuula, for help in the processing of the manuscript.

## ADDENDUM

### David Valle

In the interval since the appearance of this chapter in the seventh edition of this book, the subject of amino acid transport has been the subject of several reviews.<sup>280–282</sup> Additionally, many advances have been made in our understanding of LPI, particularly in the areas of the biochemistry and molecular biology of amino acid transport and in delineation of the molecular basis of LPI. These advances are summarized here.

### Clinical Aspects

Additional cases of hemophagocytic lymphohistiocytosis complicating LPI have been described.<sup>283,284</sup> Some have improved in association with immunosuppressive treatment<sup>284</sup> but other regress spontaneously.<sup>285</sup> Thus, the role of immunosuppression for treatment of this complication is uncertain.

### Molecular Biology of Amino Acid Transporters

Utilizing the *Xenopus* oocyte expression system to assay amino acid transport, investigators have for some time known that two homologous surface glycoproteins, rBAT and 4F2hc, induce amino



acid transport when expressed in oocytes.<sup>280–282</sup> These proteins are only slightly hydrophobic, prompting the hypothesis that they were subunits or modulators of amino acid transporters. This hypothesis was supported by several observations including (a) expression of rBAT or 4Fhc induces transport of several classes of amino acids;<sup>280–282</sup> (b) either rBAT or 4Fhc can be immunoprecipitated as a complex of  $\approx 125$  kDa in the absence of reducing agents and as monomers of  $\approx 85$  kDa (rBAT or 4F2hc) and  $\approx 40$  kDa (unknown subunit) in the presence of reducing agents;<sup>282,286</sup> and (c) in oocytes, the transport activity is less than predicted by the level of either rBAT or 4F2hc expression as if activity is limited by an endogenous factor.<sup>287,288</sup>

A major advance in identification of the partners of rBAT or 4F2hc in the heteromeric complex, came from the isolation by Verrey and colleagues of a *Xenopus* cDNA, designated ASUR4, that encodes a hydrophobic 12-transmembrane-domain protein with homology to yeast and worm amino acid transport proteins and to a partial length human cDNA known as E16.<sup>289</sup> AZUR4 or full-length E16 had no activity when expressed alone in *Xenopus* oocytes. But, when co-expressed with 4F2hc, they induced amino acid transport to a much greater extent than that produced by expression of 4F2hc alone. The substrate specificity and Na<sup>+</sup> dependence of the transport activity induced by co-expression of ASUR4 or E16 with 4F2hc corresponded functionally to the human system.<sup>280</sup> These observations suggested that ASUR4 and E16 encoded members of a family of peptides that formed the small subunit (referred to as the light chain) of the heteromeric complex with 4F2hc. Immunoprecipitation experiments confirmed that the E16 (or AZUR4) peptide was covalently linked to 4F2hc and immunohistochemistry showed this association was required for localization of the light chain in the plasma membrane. Based on these observations, Verrey and colleagues proposed that AZUR4 and E16 were members of a family of light chains that heterodimerize with 4F2hc to form amino acid transporters.<sup>289</sup>

Using a combination of degenerate primer PCR and homology probing of the EST database, Palacin and colleagues identified two newly recognized human cDNAs with homology to AZUR4.<sup>290</sup> Co-expression of either of these with 4F2hc in *Xenopus* oocytes induced amino acid transport with characteristics of the y<sup>+</sup>L system (exchanger activity mediating efflux of cationic amino acids and influx of neutral amino acids plus Na<sup>+</sup>) and on this basis the cDNAs were designated y<sup>+</sup>LAT-1 and y<sup>+</sup>LAT-2. The y<sup>+</sup>LAT-1 protein has 511 amino acids with 75 percent identity to the 515 amino acid protein encoded by y<sup>+</sup>LAT-2 and 51 percent identity to E16, the third member of this family in humans. All three are predicted to have 12 transmembrane domains. These investigators showed y<sup>+</sup>LAT-1 associates covalently with 4F2hc to form a 135-kDa complex that could be dissociated by reduction to yield a 40-kDa protein specific for y<sup>+</sup>LAT-1.<sup>290,291</sup> They suggest that y<sup>+</sup>LAT-1, y<sup>+</sup>LAT-2 and E16 can each associate with 4F2hc to form heterodimeric amino acid transporters and that the variable light chain confers the specificity of the transporter. The covalent link between the light chain and 4F2hc occurs in segments of the peptides facing the extracellular space. These correspond to a cysteine between the third and fourth transmembrane domains of the light chain (C152 for y<sup>+</sup>LAT-1) and C109 of human 4F2hc.<sup>290,291</sup> Interestingly, two additional features of y<sup>+</sup>LAT-1 suggested it could be responsible for LPI: the y<sup>+</sup>LAT-1 structural gene mapped to 14q11.2, the region implicated for LPI (see below); and northern blot analysis showed high expression in tissues involved in LPI (kidney, peripheral leukocytes, and lung).

### Molecular Basis of LPI

The key first step in this success story was localization of the gene responsible for LPI in the Finnish population to 14q11.2 in a linkage study of 20 Finn LPI pedigrees.<sup>292</sup> A second study confirmed the same location for non-Finnish LPI.<sup>293</sup> This mapping result provided a molecular signpost against which all candidates could be tested.

Recognition that the y<sup>+</sup>LAT-1 structural gene (designated *SLC7A7* for solute carrier family 7, member 7) maps to the correct location and encodes a subunit of a transporter with the expected functional characteristics, made it an excellent candidate for LPI. Torrents et al. surveyed *SLC7A* in 31 Finnish and 1 Spanish LPI patients.<sup>294</sup> They found a single Finnish mutant allele (1181-2A > T) with an A > T transversion at position -2 of the acceptor splice site in intron 6 of the *SLC7A* gene. This inactivates the normal splice acceptor and activates a cryptic acceptor 10 bp downstream with the result that 10 bp of the ORF are deleted and the reading frame is shifted. All 31 Finnish patients and 10 obligate heterozygotes had this allele. In all but one instance, this was on a common haplotype consistent with the expectation of a founder mutation in the Finnish population. The one exception appeared to result from a recombination between the haplotype markers and the LPI locus. In contrast to the Finnish patients, the Spanish LPI subject was a genetic compound for two *SLC7A* mutations: a missense mutation, L334R (1287T > G); and a 4-bp deletion (1291delCTTT). Expression studies in the oocyte system confirmed that L334R inactivated transporter function.

Simultaneously, Borsani and colleagues used homology probing with the E16 sequence to identify *SLC7A7*<sup>295</sup> independently. They performed mutation analysis in four Finn and five Italian LPI probands. They found 4 of the Italian probands were homozygous for a 4 bp insertion (1625insATAC) that frameshifts the reading frame at codon 462 and predicts translation termination 13 bp downstream. The remaining Italian proband was homozygous for a 543-bp deletion (197del543) that removes the first 168 codons of the reading frame. They also identified the 1181-2A > T mutation in their four Finnish LPI probands.

Together, the reports from these two groups confirmed *SLC7A7* as the gene responsible for LPI. Subsequent studies have delineated the organization of the *SLC7A7* structural gene. The Finnish group finds 11 exons distributed over 18 kb of genomic DNA, with the first two exons encoding 5' untranslated sequence and the open reading frame beginning in exon 3.<sup>296</sup> The Italian group did not identify the most 5' exon and therefore reports 10 exons with translation beginning in exon 2.<sup>297</sup> Together, the two groups surveyed 36 non-Finnish LPI probands for *SLC7A7* mutations, including patients of Japanese, Tunisian, Italian, Spanish, Turkish, German, Canadian, Dutch, Norwegian, and Swedish origin. The results are confused by differences in numbering exons and cDNA residues but, in toto, there are at least 5 missense alleles (M1L, G54V, L334R, G338D, S386R), 3 nonsense alleles (W242X, Y384X, R473X), 8 small insertions or deletions, and 4 splice site changes for a total of 20 alleles.<sup>296,297</sup> Five of these alleles were expressed in oocytes to determine their functional consequences. Three of these (1291delCTTT, 1548delC, and the Finnish allele, 1181-2A > T) produced an abnormal protein that did not localize to the plasma membrane. By contrast, two missense alleles (G54V and L334R) produced an abnormal protein that correctly localized to the plasma membrane but was functionally inactive.<sup>296</sup> Interestingly, both groups note that patients with the same genotype at the *SLC7A7* locus may have quite different phenotypic severity. For example, in the Finnish LPI patients, all with the same *SLC7A7* genotype, the severity ranges from nearly normal growth with minimal protein intolerance to severe cases with organomegaly, osteoporosis, alveolar proteinosis, and severe protein intolerance. Thus, there is much work to be done to understand the pathophysiology of the protean manifestations of LPI.

### REFERENCES

1. Perheentupa J, Visakorpi JK: Protein intolerance with deficient transport of basic amino acids. *Lancet* 2:813, 1965.
2. Norio R, Perheentupa J, Kekomaki M, Visakorpi JK: Lysinuric protein intolerance, an autosomal recessive disease. *Clin Genet* 2:214, 1971.
3. McKusick VA, Francomano CA, Antonarakis SE: *Mendelian Inheritance in Man. Catalogs of Autosomal Dominant, Autosomal Recessive*



- and X-linked Phenotypes, 10th ed. Baltimore, Johns Hopkins University Press, 1992, p 1336.
4. Simell O, Rajantie J, Perheentupa J: Lysinuric protein intolerance, in Eriksson AW, Forsius H, Nevanlinna HR, Workman PL, Norio RK (eds): *Population Structure and Genetic Disorders*, London, Academic Press, 1980, p 633.
  5. Scriver CR, Simell O: Hyperdibasic-aminoaciduria, in Buyse ML (ed): *Birth Defects Encyclopedia*. Dover, MA, Center for Birth Defects Information Services/Blackwell Scientific, 1990, p 900.
  6. Kekomaki M: *Familial protein intolerance. Studies on an inborn error of metabolism and related biochemical problems*. Thesis, Helsinki, 1969.
  7. Kekomaki M, Toivakka E, Hakkinen V, Salaspuro M: Familial protein intolerance with deficient transport of basic amino acids. Report on an adult patient with chronic hyperammonemia. *Acta Med Scand* 183:357, 1968.
  8. Kekomaki M, Visakorpi JK, Perheentupa J, Saxen L: Familial protein intolerance with deficient transport of basic amino acids. An analysis of 10 patients. *Acta Paediatr Scand* 56:617, 1967.
  9. Rajantie J: *Lysinuric protein intolerance: Intestinal transport defect and treatment*. Thesis, Helsinki, 1980.
  10. Simell O: *Lysinuric protein intolerance*. Thesis. Helsinki, Yliopisto-kirjapaino, 1975.
  11. Rajantie J, Simell O, Rapola J, Perheentupa J: Lysinuric protein intolerance: A two-year trial of dietary supplementation therapy with citrulline and lysine. *J Pediatr* 97:927, 1980.
  12. Perheentupa J, Simell O: Lysinuric protein intolerance. *Birth Defects* 10(4):201, 1974.
  13. Russell A, Slatter M, Ben-Zvi A: Ornithine administration as a therapeutic tool in dibasic aminoaciduric protein intolerance. *Hum Hered* 27:206, 1977.
  14. Awrich AE, Stackhouse J, Cantrell JE, Patterson JH, Rudman D: Hyperdibasicaminoaciduria, hyperammonemia, and growth retardation: Treatment with arginine, lysine, and citrulline. *J Pediatr* 87:731, 1975.
  15. Kato T, Tanaka E, Horisawa S: Hyperdibasicaminoaciduria and hyperammonemia in familial protein intolerance. *Am J Dis Child* 130:1340, 1976.
  16. Malmquist J, Jagenburg R, Lindstedt G: Familial protein intolerance: Possible nature of enzyme defect. *N Engl J Med* 284:997, 1971.
  17. Yoshimura T, Kato M, Goto I, Kuroiwa Y: Lysinuric protein intolerance—Two patients in a family with loss of consciousness and growth retardation. *Rinsho Shinkeigaku* 23:140, 1983.
  18. Kitajima I, Goto K, Umehara F, Nagamatsu K, Kanehisa Y: A case of lysinuric protein intolerance with intermittent stupor looking like psychomotor seizure in adulthood. *Rinsho Shinkeigaku* 26:592, 1986.
  19. Carson NAJ, Redmond OAB: Lysinuric protein intolerance. *Ann Clin Biochem* 14:135, 1977.
  20. Andria G, Battaglia A, Sebastio G, Strisciuglio P, Auricchio S: Lysinuric protein intolerance. *Rev Ital Pediatr* 2:386, 1977.
  21. Malmquist J, Hetter B: Leucocyte glutaminase in familial protein intolerance. *Lancet* 2:129, 1970.
  22. Behbehani AW, Gahr M, Schroter W: Lysinuric protein intolerance. *Monatsschr Kinderheilkd* 131:784, 1983.
  23. Brown JH, Fabre LF Jr, Farrell GL, Adams ED: Hyperlysinuria with hyperammonemia. *Am J Dis Child* 124:127, 1972.
  24. Oyanagi K, Sogawa H, Minami R, Nakao T, Chiba T: The mechanism of hyperammonemia in congenital lysinuria. *J Pediatr* 94:255, 1979.
  25. Oyanagi K, Miura R, Yamanouchi T: Congenital lysinuria: A new inherited transport disorder of dibasic amino acids. *J Pediatr* 77:259, 1970.
  26. Kato T, Mizutani N, Ban M: Hyperammonemia in lysinuric protein intolerance. *Pediatrics* 73:489, 1984.
  27. Chan H, Billmeier GJ Jr, Molinary SV, Tucker HN, Shin B-C, Schaffer A, Cavallo K: Prolonged coma and isoelectric electroencephalogram in a child with lysinuric protein intolerance. *J Pediatr* 91:79, 1977.
  28. Endres W, Zoulek G, Schaub J: Hyperdibasicaminoaciduria in a Turkish infant without evident protein intolerance. *Eur J Pediatr* 131:33, 1979.
  29. Jagenburg R, Lindstedt G, Malmquist J: Familjar [?] proteinintolerans med hyperammoniem. *Lakartidningen* 67:5255, 1970.
  30. Carpenter TO, Levy HL, Holtrop ME, Shih VE, Anast CS: Lysinuric protein intolerance presenting as childhood osteoporosis. Clinical and skeletal response to citrulline therapy. *N Engl J Med* 312:290, 1985.
  31. Nagata M, Suzuki M, Kawamura G, Kono S, Koda N, Yamaguchi S, Aoki K: Immunological abnormalities in a patient with lysinuric protein intolerance. *Eur J Pediatr* 146:427, 1987.
  32. Andria G, Sebastio G, Strisciuglio P, Del Giudice E: Lysinuric protein intolerance: Possible genetic heterogeneity? *J Inher Metab Dis* 4:151, 1981.
  33. Kihara H, Valente M, Porter MT, Fluharty AL: Hyperdibasicaminoaciduria in a mentally retarded homozygote with a peculiar response to phenothiazines. *Pediatrics* 51:223, 1973.
  34. Goto I, Yoshimura T, Kuroiwa Y: Growth hormone studies in lysinuric protein intolerance. *Eur J Pediatr* 141:240, 1984.
  35. Simell O, Perheentupa J, Rapola J, Visakorpi JK, Eskelin L-E: Lysinuric protein intolerance. *Am J Med* 59:229, 1975.
  36. Yamaguchi S: Personal communication, 1987.
  37. Saudubray JM: Personal communication, 1987.
  38. Fisher M, Roggli V, Merten D, Mulvihill D, Spock A: Coexisting endogenous lipoid pneumonia, cholesterol granulomas, and pulmonary alveolar proteinosis in a pediatric population: A clinical, radiographic, and pathologic correlation. *Pediatr Pathol* 12:365, 1992.
  39. Krasnopolskaia KD, Iakovenko LP, Mazaeva IV, Lebedev BV: Lysinuric protein intolerance, a hereditary defect of amino acid transport. *Pediatriia* 6:78, 1978.
  40. Coude FX, Ogier H, Charpentier C, Cathelineau L, Grimber G, Parvy P, Saudubray JM, Frezal J: Lysinuric protein intolerance: A severe hyperammonemia secondary to L-arginine deficiency. *Arch Fr Pediatr* 38(Suppl 1):829, 1981.
  41. Mori H, Kimura M, Fukuda S: A case of lysinuric protein intolerance with mental-physical retardation, intermittent stupor and hemiparesis. *Rinsho Shinkeigaku* 22:42, 1982.
  42. Mizutani N, Kato T, Maehara M, Watanabe K, Ban M: Oral administration of arginine and citrulline in the treatment of lysinuric protein intolerance. *Tohoku J Exp Med* 142:15, 1984.
  43. Rottlem M, Statter M, Amit R, Brand N, Bujanover Y, Yatziv S: Clinical and laboratory study in 22 patients with inherited hyperammonemic syndromes. *Isr J Med Sci* 22:833, 1986.
  44. Takada G, Goto A, Komatsu K, Goto R: Carnitine deficiency in lysinuric protein intolerance: Lysine sparing effect of carnitine. *Tohoku J Exp Med* 153:331, 1987.
  45. Shioya K, Yamamura Y, Kurihara T, Matsukura S: A case of combined lysinuric protein intolerance and hypoactivity of argininosuccinate synthetase (citrullinemia). *Nippon Naika Gakkai Zasshi* 77:667, 1988.
  46. De Parshau L, Vianey-Liaud C, Hermier M, Divry P, Guibaud P: Protein intolerance with lysinuria. Value of orotic aciduria in adjusting treatment with citrulline. *Arch Fr Pediatr* 45:809, 1988.
  47. Shaw PJ, Dale G, Bbates D: Familial lysinuric protein intolerance presenting as coma in two adult sblings. *J Neurol Neurosurg Psychiatry* 52:648, 1989.
  48. Kato T, Sano M, Mizutani N: Homocitrullinuria and homoargininuria in lysinuric protein intolerance. *J Inher Metab Dis* 12:157, 1989.
  49. Parini R, Vegni M, Pontiggia M, Melotti D, Corbetta C, Rossi A, Piceni-Sereni L: A difficult diagnosis of lysinuric protein intolerance: Association with glucose-6-phosphate dehydrogenase deficiency. *J Inher Metab Dis* 14:833, 1991.
  50. Ono N, Kishida K, Tokumoto K, Watanabe M, Shimada Y, Yoshinaga J, Fujii M: Lysinuric protein intolerance presenting deficiency of argininosuccinate synthetase. *Intern Med* 31:55, 1992.
  51. DiRocco M, Garibotto G, Rossi GA, Caruso U, Taccone A, Picco P, Borroni C: Role of haematological, pulmonary and renal complications in the long-term prognosis of patients with lysinuric protein intolerance. *Eur J Pediatr* 152:437, 1993.
  52. Kerem E, Elpelg ON, Shalev RS, Rosenman E, Bar Ziv Y, Branski D: Lysinuric protein intolerance with chronic interstitial lung disease and pulmonary cholesterol granulomas at onset. *J Pediatr* 123:275, 1993.
  53. Salonen T: *Lysinuric protein intolerance: Finnish pedigrees and the diagnosis of heterozygotes*. Master's thesis. Turku, University of Turku, 1991.
  54. Sogowa H: Studies on the etiology of hyperammonemia associated with inborn errors of amino acid metabolism, part 2: Etiology of hyperammonemia associated with hyperdibasic aminoaciduria. *Sapporo Med J* 47:215, 1978.
  55. Rajantie J, Simell O, Perheentupa J: Basolateral-membrane transport defect for lysine in lysinuric protein intolerance. *Lancet* 1:1219, 1980.
  56. Rajantie J, Simell O, Perheentupa J: Lysinuric protein intolerance. Basolateral transport defect in renal tubuli. *J Clin Invest* 67:1078, 1981.



57. Desjeux J-F, Rajantie J, Simell O, Dumontier A-M, Perheentupa J: Lysine fluxes across the jejunal epithelium in lysinuric protein intolerance. *J Clin Invest* 65:1382, 1980.
58. Smith DW, Scriver CR, Tenenhouse HS, Simell O: Lysinuric protein intolerance mutation is expressed in the plasma membrane of cultured skin fibroblasts. *Proc Natl Acad Sci U S A* 84:7711, 1987.
59. Botschner J, Smith DW, Simell O, Scriver CR: Comparison of ornithine metabolism in hyperornithinemia-hyperammonemia-homocitrullinuria syndrome, lysinuric protein intolerance, and gyrate atrophy fibroblasts. *J Inher Metab Dis* 12:33, 1989.
60. Albritton LM, Bowcock AM, Eddy RL, Morton CC, Tseng L, Farrer LA, Cavalli-Sforza LL, Shows TB, Cunningham JM: The human cationic amino acid transporter [ATRC1]: Physical and genetic mapping to 13q12-q14. *Genomics* 12:430, 1992.
61. Whelan DT, Scriver CR: Hyperbasicaminoaciduria: An inherited disorder of amino acid transport. *Pediatr Res* 2:525, 1968.
62. Omura K, Yamanaka N, Higami S, Matsuoka O, Fujimoto A, Issiki G, Tada K: Lysine malabsorption syndrome: A new type of transport defect. *Pediatrics* 57:102, 1976.
63. Parto K: *Skeletal and visceral findings in lysinuric protein intolerance*. Thesis. Turku, Grafia, 1993.
64. Svedstrom E, Parto K, Marttinen M, Virtama P, Simell O: Skeletal manifestations of lysinuric protein intolerance. *Skeletal Radiol* 22:11, 1993.
65. Parto K, Penttinen R, Paronen I, Pelliniemi L, Simell O: Osteoporosis in lysinuric protein intolerance. *J Inher Metab Dis* 16:441, 1993.
66. Lysinuric protein intolerance: A rare cause of childhood osteoporosis. *Nutr Rev* 44:110, 1986. (no author)
67. Moschos M, Andreanos D: Lysinuria and changes in the crystalline lens. *Bull Mem Soc Fr Ophthalmol* 96:322, 1985.
68. Neuberger A, Webster TA: The lysine requirements of adult rat. *J Biochem* 39:200, 1945.
69. Likens R, Bavetta L, Posner A: Calcification in lysine deficiency. *Arch Biochem Biophys* 70:401, 1957.
70. Jha G, Deo MG, Ramalingaswami V: Bone growth in protein deficiency, a study in rhesus monkeys. *Am J Pathol* 53:1111, 1968.
71. Garn SM, Guzman MA, Wagner B: Subperiosteal gain and endosteal loss in protein-calorie malnutrition. *Am J Phys Anthropol* 30:153, 1969.
72. Shieres R, Avioli LV, Bergfeld MA, Fallon MD, Slatopolsky E, Teitelbaum SL: Effects of semistarvation on skeletal homeostasis. *Endocrinology* 107:1530, 1980.
73. Orwoll E, Ware M, Sstribrska L, Bikle D, Sanchez T, Andon M, Li H: Effects of dietary protein deficiency on mineral metabolism and bone mineral density. *Am J Clin Nutr* 56:314, 1992.
74. Branca F, Robin SP, Ferro-Luzzi A, Golden MHN: Bone turnover in malnourished children. *Lancet* 340:1493, 1992.
75. Parto K, Kallajoki M, Aho H, Simell O: Pulmonary alveolar proteinosis and glomerulonephritis in lysinuric protein intolerance: Case reports and autopsy findings of four pediatric patients. *Hum Pathol* (In press).
76. Dhansay MA, Benade AJ, Donald PR: Plasma lecithin-cholesterol acyltransferase activity and plasma lipoprotein composition and concentrations in kwashiorkor. *Am J Clin Nutr* 53:512, 1991.
77. Sidransky H, Verney E: Chemical pathology of diamino acid deficiency: Considerations in relation to lysinuric protein intolerance. *J Exp Pathol* 2:47, 1985.
78. Parto K, Svedstrom E, Majurin ML, Harkonen R, Simell O: Pulmonary manifestations in lysinuric protein intolerance. *Chest* 104:1176, 1993.
79. Parto K, Maki J, Pelliniemi L, Simell O: Abnormal pulmonary macrophages in lysinuric protein intolerance. Ultrastructural, morphometric and x-ray microanalytical study. *Arch Pathol Lab Med* (In press).
80. Simell OG, Sipila I, Perheentupa J, Rapola J: *Lysinuric protein intolerance: Undefined interstitial pneumonia, a lethal or life-threatening complication* [Abstract]. Sendai, Japan, The Fourth International Congress of Inborn Errors of Metabolism, 1987, p 38.
81. Bone RC, Balk RA, Cerra FB, Dellinger RP, Fein AM, Knaus WA, Schein RMH, Sibbald WJ: Definitions for sepsis and organ failure and guidelines for the use of innovative therapies in sepsis. *Chest* 101:1644, 1992.
82. Cohen IL: Definitions for sepsis and organ failure—The ACCP/SCCM consensus conference report. *Chest* 103:656, 1993.
83. Wallaert B: Subclinical alveolitis in immunologic systemic disorders. *Lung* 168(Suppl):974, 1990.
84. Milleron BJ, Costabel U, Teschler H, Ziesche R, Cadranel JL, Matthys H, Akoun GM: Bronchoalveolar lavage cell data in alveolar proteinosis. *Am Rev Respir Dis* 144:1330, 1991.
85. Hallman M, Sipila I: *Lysinuric protein intolerance (LPI): A possible defect in diamino acid transport in pulmonary alveolar epithelium* [Abstract]. Oslo, Norway, European Society for Pediatric Research, Annual Meeting, 1988.
86. Hallman M, Maasilta P, Sipila I, Tahvanainen J: Composition and function of pulmonary surfactant in adult respiratory distress syndrome. *Eur Respir J* 2(Suppl 3):104, 1989.
87. Pratt SA, Smith MH, Ladman AJ, Finley TN: The ultrastructure of alveolar macrophages from human cigarette smokers and nonsmokers. *Lab Invest* 24:331, 1971.
88. Hocking WG, Golde DW: The pulmonary alveolar macrophage. *N Engl J Med* 301:639, 1979.
89. Heppleston AG: Animal model of human disease. Silica induced pulmonary alveolar lipoproteinosis. *Am J Pathol* 78:171, 1975.
90. Lullmann H, Lullmann-Rauch R, Wasserman O: Lipidosis induced by amphiphilic cationic drugs. *Biochem Pharmacol* 27:1103, 1978.
91. Hook GER: Alveolar proteinosis and phospholipidoses of the lung. *Toxicol Pathol* 19:482, 1991.
92. Colon AR Jr, Lawrence RD, Mills SD, O'Connell EJ: Childhood pulmonary alveolar proteinosis [PAP]. Report of a case and review of the literature. *Am J Dis Child* 121:481, 1971.
93. Webster JR Jr, Battifora H, Fureay C, Harrison RA, Shapiro B: Pulmonary alveolar proteinosis in two siblings with decreased immunoglobulin A. *Am J Med* 69:786, 1980.
94. Gray ES: Autoimmunity in childhood pulmonary alveolar proteinosis. *Br Med J* 887:296, 1973.
95. Samuels MP, Warner JO: Pulmonary alveolar lipoproteinosis complicating juvenile dermatomyositis. *Thorax* 43:939, 1988.
96. Haworth JC, Hoogstraten J, Taylor H: Thymic aplasia. *Arch Dis Child* 42:40, 1967.
97. Wilkinson RH, Blanc WA, Hagstrom JWC: Pulmonary alveolar proteinosis in three infants. *Pediatrics* 41:510, 1968.
98. Danigelis JA, Markarian B: Pulmonary alveolar proteinosis. Including pulmonary electron microscopy. *Am J Dis Child* 118:871, 1969.
99. Lippman M, Mok MS, Wasserman K: Anesthetic management for children with alveolar proteinosis using extracorporeal circulation. Report of two cases. *Br J Anaesthesiol* 49:173, 1977.
100. Teja K, Cooper PH, Shires JE, Schnatterly PT: Pulmonary alveolar proteinosis in four siblings. *N Engl J Med* 305:1390, 1981.
101. Schumacher RE, Marrogi AJ, Heidelberger KP: Pulmonary alveolar proteinosis in a newborn. *Pediatr Pulmonology* 7:178, 1989.
102. Moulton SL, Krous HF, Merritt TA, Odell RM, Gangitano E, Cornish JD: Congenital pulmonary alveolar proteinosis: Failure of treatment with extracorporeal life support. *J Pediatr* 120:297, 1992.
103. Porter KA: The kidneys, in Symmers WS (ed): *Systemic Pathology*. Edinburgh, Churchill Livingstone, 1992, p 217.
104. Marino CT, Pertschuk LP: Pulmonary hemorrhage in systemic lupus erythematosus. *Arch Intern Med* 141:201, 1981.
105. Hensley MJ, Feldman NT, Lazarus JM, Galvanek EG: Diffuse pulmonary hemorrhage and rapidly progressive renal failure: An uncommon presentation of Wegener's granulomatosis. *Am J Med* 66:894, 1979.
106. Thomashow BM, Felton CP, Navarro C: Diffuse intrapulmonary hemorrhage, renal failure, and a systemic vasculitis. *Am J Med* 68:299, 1980.
107. Loughlin GM, Taussig LM, Murphy SA, Strunk RC, Kohlen PW: Immune complex-mediated glomerulonephritis and pulmonary hemorrhage simulating Goodpasture's syndrome. *J Pediatr* 93:181, 1978.
108. Davies JNP: The essential pathology of kwashiorkor. *Lancet* 1:317, 1948.
109. Gmaz-Nikulina E, Nikulina A, Plamenac P, Hegenwald G, Gaon D: Pancreatic lesions in shock and their significance. *J Pathol* 135:223, 1981.
110. Klujber V, Klujber L: Hereditary pancreatitis. *Orv Hetil* 130:1777, 1989.
111. Rajantie J, Simell O, Perheentupa J, Siimes M: Changes in peripheral blood cells and serum ferritin in lysinuric protein intolerance. *Acta Paediatr Scand* 69:741, 1980.
112. Simell O, MacKenzie S, Clow CL, Scriver CR: Ornithine loading did not prevent induced hyperammonemia in a patient with HHH syndrome. *Pediatr Res* 19:1283, 1985.
113. Coude FX, Coude M, Grimber G, Pelet A, Charpentier C: Potentiation by piridoxilate of the synthesis of hippurate from benzoate in isolated rat hepatocytes. An approach to the determination of new pathways of



- nitrogen excretion in inborn errors of urea synthesis. *Clin Chim Acta* **136**:211, 1984.
114. Brusilow SW: Arginine, an indispensable amino acid for patients with inborn errors of urea synthesis. *J Clin Invest* **74**:2144, 1984.
  115. Vissek WJ: Arginine needs, physiological state and usual diets. A reevaluation. *J Nutr* **116**:36, 1986.
  116. Brusilow SW, Danney M, Waber LJ, Batshaw M, Burton B, Levitsky L, Roth K, McKeethren C, Ward J: Treatment of episodic hyperammonemia in children with inborn errors of urea synthesis. *N Engl J Med* **310**:1630, 1984.
  117. Batshaw ML, Painter MJ, Sproul GT, Schafer IA, Thomas GH, Brusilow S: Therapy of urea cycle enzymopathies: Three case studies. *Johns Hopkins Med* **148**:34, 1981.
  118. Brusilow S, Tinker J, Batshaw ML: Amino acid acylation: A mechanism of nitrogen excretion in inborn errors of urea synthesis. *Science* **207**:659, 1980.
  119. Smith I: The treatment of inborn errors of the urea cycle. *Nature* **291**:378, 1981.
  120. McCormick K, Viscardi RM, Robinson B, Heininger J: Partial pyruvate decarboxylase deficiency with profound lactic acidosis and hyperammonemia: Responses to dichloroacetate and benzoate. *Am J Med Genet* **22**:291, 1985.
  121. Simell O, Perheentupa J: Renal handling of diamino acids in lysinuric protein intolerance. *J Clin Invest* **54**:9, 1974.
  122. Rajantie J: Orotic aciduria in lysinuric protein intolerance: Dependence on the urea cycle intermediates. *Pediatr Res* **15**:115, 1981.
  123. Wendler PA, Blanding JH, Tremblay GC: Interaction between the urea cycle and the orotate pathway: Studies with isolated hepatocytes. *Arch Biochem Biophys* **224**:36, 1983.
  124. Milner JA, Prior RL, Vissek WJ: Arginine deficiency and orotic aciduria in mammals. *Proc Soc Exp Biol Med* **150**:282, 1975.
  125. Milner JA, Vissek WJ: Urinary metabolites characteristic of urea-cycle amino acid deficiency. *Metabolism* **24**:643, 1975.
  126. Kelley WN, Greene ML, Fox IH, Rosenbloom FM, Levy RI, Seegmiller JE: Effects of orotic acid on purine and lipoprotein metabolism in man. *Metabolism* **19**:1025, 1970.
  127. Rajantie J, Rapola J, Siimes MA: Ferritinemia with subnormal iron stores in lysinuric protein intolerance. *Metabolism* **30**:3, 1981.
  128. Lamberg B-A, Simell O, Perheentupa J, Saarinen P: Increase in TBG, T4, FT4 and T3 in the lysinuric protein intolerance. *Excerpta Medica Int Congress Series* **378**:232, 1975.
  129. Lamberg BA, Perheentupa J, Rajantie J, Simell O, Saarinen P, Ebeling P, Welin M-G: Increase in thyroxine-binding globulin [TBG] in lysinuric protein intolerance. *Acta Endocrinol* **97**:67, 1981.
  130. Kekomaki M, Raiha NCR, Perheentupa J: Enzymes of urea synthesis in familial protein intolerance with deficient transport of basic amino acids. *Acta Paediatr Scand* **56**:631, 1967.
  131. Simell O, Perheentupa J, Visakorpi JF: Leukocyte and liver glutaminase in lysinuric protein intolerance. *Pediatr Res* **6**:797, 1972.
  132. Kekomaki MP, Raiha NCR, Bickel H: Ornithine-ketoacid aminotransferase in human liver with reference to patients with hyperornithinaemia and familial protein intolerance. *Clin Chim Acta* **23**:203, 1969.
  133. Valle D: Personal communication, 1988.
  134. Simell O, Sipilä I, Rajantie J, Valle DL, Brusilow SW: Waste nitrogen excretion via amino acid acylation: Benzoate and phenylacetate in lysinuric protein intolerance. *Pediatr Res* **20**:1117, 1986.
  135. Bachmann C, Krahenbuhl S, Colombo JP, Schubiger G, Jaggi KH, Tonz O: N-acetylglutamate synthetase deficiency: A disorder of ammonia detoxication. *N Engl J Med* **304**:543, 1981.
  136. Hammerman MR: Na<sup>+</sup>-independent L-arginine transport in rabbit renal brush border membrane vesicles. *Biochim Biophys Acta* **685**:71, 1982.
  137. Adibi SA: Intestinal transport of dipeptides in man: Relative importance of hydrolysis and intact absorption. *J Clin Invest* **50**:2266, 1971.
  138. Matthews DM, Adibi SA: Peptide absorption. *Gastroenterology* **71**:151, 1976.
  139. Asatoor AM, Groughman MR, Harrison AR, Light FW, Loughridge LW, Milne MD, Richards AJ: Intestinal absorption of oligopeptides in cystinuria. *Clin Sci* **41**:23, 1971.
  140. Ganapathy V, Mendicino JF, Leibach FH: Transport of glycyl-L-proline into intestinal and renal brush border vesicles from rabbit. *J Biol Chem* **256**:118, 1981.
  141. Ganapathy V, Mendicino J, Pashley DH, Leibach FH: Carrier-mediated transport of glycyl-L-proline in renal brush-border vesicles. *Biochem Biophys Res Commun* **97**:1133, 1980.
  142. Scriver CR, McInnes RR, Mohyuddin F: Role of epithelial architecture and intracellular metabolism in proline uptake and transtubular reclamation in PRO/Re mouse kidney. *Proc Natl Acad Sci U S A* **72**:1431, 1975.
  143. Bergeron M, Scriver CR: Pathophysiology of renal hyperaminoacidurias and glucosuria, in Seldin DW, Giebisch G (eds): *The Kidney. Physiology and Pathophysiology*, 2nd ed. New York, Raven, 1992, p 2947.
  144. Wilson OH, Scriver CR: Specificity of transport of neutral and basic amino acids in rat kidney. *Am J Physiol* **213**:185, 1967.
  145. Webber WA, Brown JL, Pitts RF: Interactions of amino acids in renal tubular transport. *Am J Physiol* **200**:380, 1961.
  146. Steiger B, Stange G, Biber J, Murer H: Transport of L-lysine by rat renal brush border membrane vesicles. *Pflugers Arch* **397**:106, 1983.
  147. Scriver CR, Clow CL, Reade TM, Goodyer P, Auray-Blais C, Giguere R, Lemieux B: Ontogeny modifies manifestations of cystinuria genes. Implications for counseling. *J Pediatr* **106**:411, 1985.
  148. Schwartzman L, Blair A, Segal S: A common renal transport system for lysine, ornithine, arginine and cysteine. *Biochem Biophys Res Commun* **23**:220, 1966.
  149. Schafer JA, Watkins ML: Transport of L-cystine in isolated perfused proximal straight tubules. *Pflugers Arch* **401**:143, 1984.
  150. Samarzija I, Fromter E: Electrophysiological analysis of rat renal sugar and amino acid transport. IV. Basic amino acids. *Pflugers Arch* **393**:199, 1982.
  151. Rosenberg LE, Downing SJ, Segal S: Competitive inhibition of dibasic amino acid transport in rat kidney. *J Biol Chem* **237**:2265, 1962.
  152. Rosenberg LE, Albrecht I, Segal S: Lysine transport in human kidney: Evidence for two systems. *Science* **155**:1426, 1967.
  153. Bergeron M, Morel F: Amino acid transport in rat renal tubules. *Am J Physiol* **216**:1139, 1969.
  154. Crawhall JC, Scowen EF, Thompson CJ, Watts RWE: The renal clearance of amino acids in cystinuria. *J Clin Invest* **46**:1162, 1967.
  155. Hilden SA, Sacktor B: L-Arginine uptake into renal brush membrane vesicles. *Arch Biochem Biophys* **210**:289, 1981.
  156. Kato T, Mizutani N, Ban M: Renal transport of lysine and arginine in lysinuric protein intolerance. *Eur J Pediatr* **139**:181, 1982.
  157. Leopolder A, Burchhardt G, Murer H: Transport of L-ornithine across isolated brush border membrane vesicles from proximal tubule. *Renal Physiol* **2**:157, 1980.
  158. McCarthy CF, Borland JL Jr, Lynch HJ Jr, Owen EE, Tyor MP: Defective uptake of basic amino acids and L-cystine by intestinal mucosa of patients with cystinuria. *J Clin Invest* **43**:1518, 1964.
  159. Ozegovic B, McNamara D, Segal S: Cystine uptake by rat jejunal brush border membrane vesicles. *Biosci Rep* **2**:913, 1982.
  160. Thier SO, Segal S, Fox M, Blair A, Rosenberg LE: Cystinuria: Defective intestinal transport of dibasic amino acids and cystine. *J Clin Invest* **44**:442, 1965.
  161. White MF: The transport of cationic amino acids across the plasma membrane of mammalian cells. *Biochim Biophys Acta* **822**:355, 1985.
  162. White MF, Christensen HN: Cationic amino acid transport into cultured animal cells. II. Transport system barely perceptible in ordinary hepatocytes, but active in hepatoma cell lines. *J Biol Chem* **257**:4450, 1982.
  163. White MF, Gazzola GC, Christensen HN: Cationic amino acid transport into cultured animal cells. I. Influx into cultured human fibroblasts. *J Biol Chem* **257**:4443, 1982.
  164. Bannai S: Transport of cystine and cysteine in mammalian cells. *Biochim Biophys Acta* **779**:289, 1984.
  165. Dent CE, Rose GA: Aminoacid metabolism in cystinuria. *Q J Med* **79**:205, 1951.
  166. Foreman JW, Hwang S-M, Segal S: Transport interactions of cystine and dibasic amino acids in isolated rat renal tubules. *Metabolism* **29**:53, 1980.
  167. Foreman JW, Medow MS, Bovee KC, Segal S: Developmental aspects of cystine transport in the dog. *Pediatr Res* **20**:593, 1986.
  168. Groth U, Rosenberg LE: Transport of dibasic amino acids, cystine, and tryptophan by cultured human fibroblast: Absence of a defect in cystinuria and Hartnup disease. *J Clin Invest* **51**:2130, 1972.
  169. Kato T: Renal handling of dibasic amino acids and cystine in cystinuria. *Clin Sci Mol Med* **53**:9, 1977.
  170. Kato T: Renal transport of lysine and arginine in cystinuria. *Tohoku J Exp Med* **139**:9, 1983.
  171. Lester FT, Cusworth DC: Lysine infusion in cystinuria: Theoretical renal thresholds for lysine. *Clin Sci* **44**:99, 1973.
  172. McNamara D, Pepe M, Segal S: Cystine uptake by rat renal brush border vesicles. *Biochem J* **194**:443, 1981.



173. Morin CL, Thompson MW, Jackson SH, Sass-Kortsak A: Biochemical and genetic studies in cystinuria: Observations on double heterozygotes of genotype I/II. *J Clin Invest* 50:1961, 1971.
174. Robson EB, Rose GA: The effect of intravenous lysine of the renal clearances of cystine, arginine and ornithine in normal subjects, in patients with cystinuria and Fanconi syndrome and in their relatives. *Clin Sci* 16:75, 1957.
175. Rosenberg LE: Cystinuria: Genetic heterogeneity and allelism. *Science* 154:1341, 1966.
176. Segal S, McNamara PD, Pepe CM: Transport interaction of cystine and dibasic amino acids in renal brush border vesicles. *Science* 197:169, 1977.
177. Volkl H, Silbernagl S: Mutual inhibition of L-cystine/cysteine and other neutral amino acids during tubular reabsorption. A microperfusion study in rat kidney. *Pflugers Arch* 395:190, 1982.
178. Volkl H, Silbernagl S: Reexamination of the interplay between dibasic amino acids and L-cystine/L-cysteine during tubular reabsorption. *Pflugers Arch* 395:196, 1982.
179. Thier S, Foc M, Segal S: Cystinuria: In vitro demonstration of an intestinal transport defect. *Science* 143:482, 1964.
180. Scriver CR, Chesney RW, McInnes RR: Genetic aspects of renal tubular transport. Diversity and topology of carriers. *Kidney Int* 9:149, 1976.
181. Strauven T, Mardens Y, Clara R, Terheggen H: Intravenous loading with arginine-hydrochloride and ornithine-aspartate in sibs of two families, presenting a familial neurological syndrome associated with cystinuria. *Biomedicine* 24:191, 1976.
182. Frimpter GW, Horwith M, Furth E, Fellows RE, Thompson DD: Inulin and endogenous amino acid renal clearances in cystinuria: Evidence for tubular secretion. *J Clin Invest* 41:281, 1962.
183. Bovee KC, Segal S: Renal tubule reabsorption of amino acids after lysine loading of cystinuric dogs. *Metabolism* 33:602, 1984.
184. Bowring MA, Foreman JW, Lee J, Segal S: Characteristics of lysine transport by isolated rat renal cortical tubule fragments. *Biochim Biophys Acta* 901:23, 1987.
185. States B, Foreman J, Lee J, Harris D, Segal S: Cystine and lysine transport in cultured human renal epithelial cells. *Metabolism* 36:356, 1987.
186. Stevens BR, Ross HJ, Wright EM: Multiple transport pathways for neutral amino acids in rabbit jejunal brush border vesicles. *J Membr Biol* 66:213, 1982.
187. Busse D: Transport of L-arginine in brush border vesicles derived from rabbit kidney cortex. *Arch Biochem Biophys* 191:551, 1978.
188. Coicadan L, Heyman M, Grasset E, Desjeux J-F: Cystinuria: Reduced lysine permeability at the brush border of intestinal membrane cells. *Pediatr Res* 14:109, 1980.
189. Desjeux JF, Volanthen M, Dumontier AM, Simell O, Legrain M: Cystine fluxes across the isolated jejunal epithelium in cystinuria: Increased efflux permeability at the luminal membrane. *Pediatr Res* 21:477, 1987.
190. Simell O: Diamino acid transport into granulocytes and liver slices of patients with lysinuric protein intolerance. *Pediatr Res* 9:504, 1975.
191. Metoki K, Hommes FA: The uptake of ornithine and lysine by isolated hepatocytes and fibroblasts. *Int J Biochem* 16:833, 1984.
192. Scriver CR: Cystinuria. *N Engl J Med* 315:1155, 1986.
193. Frimpter GW: Cystinuria: Metabolism of the disulfide of cysteine and homocysteine. *J Clin Invest* 42:1956, 1963.
194. Kekomaki M: Intestinal absorption of L-arginine and L-lysine in familial protein intolerance. *Ann Paediatr Fenn* 14:18, 1968.
195. Rajantie J, Simell O, Perheentupa J: Oral administration of urea cycle intermediates in lysinuric protein intolerance: Effect on plasma and urinary arginine and ornithine. *Metabolism* 32:49, 1983.
196. Rajantie J, Simell O, Perheentupa J: Intestinal absorption in lysinuric protein intolerance: Impaired for diamino acids, normal for citrulline. *Gut* 21:519, 1980.
197. Silk DBA: Peptide absorption in man. *Gut* 15:494, 1974.
198. Simell O, Perheentupa J: Defective metabolic clearance of plasma arginine and ornithine in lysinuric protein intolerance. *Metabolism* 23:691, 1974.
199. Christensen HN, Cullen AM: Synthesis of metabolism-resistant substrates for the transport system for cationic amino acids; their stimulation of the release of insulin and glucagon, and of the urinary loss of amino acids related to cystinuria. *Biochim Biophys Acta* 298:932, 1973.
200. Buchanan JA, Rosenblatt DS, Scriver CR: Cultured human fibroblasts and plasma membrane vesicles to investigate transport function and the effects of genetic mutation. *Ann NY Acad Sci* 456:401, 1985.
201. Smith DW, Scriver CR, Simell O: Lysinuric protein intolerance mutation is not expressed in the plasma membrane of erythrocytes. *Hum Genet* 80:395, 1988.
202. Gardner JD, Levy AG: Transport of dibasic amino acids by human erythrocytes. *Metabolism* 21:413, 1972.
203. Christensen HN, Antonoli JA: Cationic amino acid transport in the rabbit reticulocyte. *J Biol Chem* 244:1497, 1969.
204. Vadgama JV, Christensen HN: Discrimination of Na<sup>+</sup>-independent transport systems L, T, and ASC in erythrocytes. Na<sup>+</sup> independence of the latter a consequence of cell maturation? *J Biol Chem* 260:2912, 1985.
205. Rajantie J, Simell O, Perheentupa J: "Basolateral" and mitochondrial membrane transport defect in the hepatocytes in lysinuric protein intolerance. *Acta Paediatr Scand* 72:65, 1983.
206. Gamble JG, Lehninger AL: Transport of ornithine and citrulline across the mitochondrial membrane. *J Biol Chem* 248:610, 1973.
207. Aronson DL, Diwan JJ: Uptake of ornithine by rat liver mitochondria. *Biochemistry* 20:7064, 1981.
208. Metoki K, Hommes FA: A possible rate limiting factor in urea synthesis by isolated hepatocytes: The transport of ornithine into hepatocytes and mitochondria. *Int J Biochem* 16:1155, 1984.
209. Hommes FA, Kitchings L, Eller AG: The uptake of ornithine and lysine by rat liver mitochondria. *Biochem Med* 30:313, 1983.
210. Bradford NM, McGivan JD: Evidence for the existence of an ornithine/citrulline antiporter in rat liver mitochondria. *FEBS Lett* 113:294, 1980.
211. Rajman L: Citrulline synthesis in rat tissues and liver content of carbamoyl phosphate and ornithine. *Biochem J* 138:225, 1974.
212. Bryla J, Harris EJ: Accumulation of ornithine and citrulline in rat liver mitochondria in relation to citrulline formation. *FEBS Lett* 72:331, 1976.
213. Cohen NS, Cheung C-W, Rajman L: Channeling of extramitochondrial ornithine to matrix ornithine transcarbamylase. *J Biol Chem* 262:203, 1987.
214. Cohen NS, Cheung C-W, Rajman L: The effects of ornithine on mitochondrial carbamoyl phosphate synthesis. *J Biol Chem* 255:10248, 1980.
215. Grays RGF, Hill SE, Pollitt RJ: Studies on the pathway from ornithine to proline in cultured skin fibroblasts with reference to the defect in hyperornithinaemia with hyperammonaemia and homocitrullinuria. *J Inher Metab Dis* 6:143, 1983.
216. Grays RGF, Hill SE, Pollitt RJ: Reduced ornithine catabolism in culture fibroblasts and phytohaemagglutinin-stimulated lymphocytes from a patient with hyperornithinaemia, hyperammonaemia and homocitrullinuria. *Clin Chim Acta* 118:141, 1982.
217. Shih VE: Regulation of ornithine metabolism. *Enzyme* 26:254, 1981.
218. Shih VE, Mandell R: Defective ornithine metabolism in the syndrome of hyperornithinaemia, hyperammonaemia and homocitrullinuria. *J Inher Metab Dis* 4:95, 1981.
219. Vici CD, Bachmann C, Gambarara M, Colombo JP, Sabetta G: Hyperornithinemia-hyperammonemia-homocitrullinuria syndrome: Low creatine excretion and effect of citrulline, arginine, or ornithine supplement. *Pediatr Res* 22:364, 1987.
220. Inoue I, Saheki T, Kayanuma K, Uono M, Nakajima M, Takeshita K, Koike R, Yuasa T, Miyatake T, Sakoda K: Biochemical analysis of decreased ornithine transport activity in the liver mitochondria from patients with hyperornithinemia, hyperammonemia and homocitrullinuria. *Biochim Biophys Acta* 964:90, 1988.
221. Inoue I, Koura M, Saheki T, Kayanuma K, Uono M, Nakajima M, Takeshita K, Koike R, Yuasa T, Miyatake T, Sakoda K: Abnormality of citrulline synthesis in liver mitochondria from patients with hyperornithinaemia, hyperammonaemia and homocitrullinuria. *J Inher Metab Dis* 10:277, 1987.
222. Gatfield PD, Tallor E, Wolfe DM, Haust DM: Hyperornithinemia, hyperammonemia, and homocitrullinuria associated with decreased carbamyl phosphate synthetase I activity. *Pediatr Res* 9:488, 1975.
223. Hommes FA, Roesel RA, Metoki K, Hartlage PL, Dyken PR: Studies on a case of HHH-syndrome (hyperammonemia, hyperornithinemia, homocitrullinuria). *Neuropediatrics* 17:48, 1986.
224. Hommes FA, Ho CK, Roesel RA, Coryell ME: Decreased transport of ornithine across the inner mitochondrial membrane as a cause of hyperornithinemia. *J Inher Metab Dis* 5:41, 1982.
225. Oyanagi K, Tsuchiyama A, Itakura Y, Sogawa H, Wagatsuma K, Nakao T: The mechanism of hyperammonaemia and hyperornithinaemia in the syndrome of hyperornithinaemia, hyperammonaemia and homocitrullinuria. *J Inher Metab Dis* 6:133, 1983.



226. Shih VE, Efron ML, Moser HW: Hyperornithinemia, hyperammonemia, and homocitrullinuria. A new disorder of amino acid metabolism associated with myoclonic seizures and mental retardation. *Am J Dis Child* 117:83, 1969.
227. Koike R, Fujimori K, Yuasa T, Miyatake T, Inoue I, Saheki T: Hyperornithinemia, hyperammonemia, and homocitrullinuria: Case report and biochemical study. *Neurology* 37:1813, 1987.
228. Pisoni RL, Thoene JG, Christensen HN: Detection and characterization of carrier-mediated cationic amino acid transport in lysosomes of normal and cystinotic human fibroblasts. *J Biol Chem* 260:4791, 1985.
229. Aula P, Autio S, Raivio KO, Rapola J, Thoden C-J, Koskela S-L, Yamashina I: "Salla Disease." A new lysosomal storage disorder. *Arch Neurol* 36:88, 1979.
230. Gahl WA, Bashan N, Iteze F, Bernardini I, Schulman JD: Cystine transport is defective in isolated leukocyte lysosomes from patients with cystinosis. *Science* 217:1263, 1982.
231. Renlund M, Aula P, Raivio KO, Autio S, Sainio K, Rapola J, Koskela S-L: Salla disease: A new lysosomal storage disorder with disturbed sialic acid metabolism. *Neurology* 33:57, 1983.
232. Renlund M, Kovanen PT, Raivio KO, Aula P, Gahmberg CG, Ehnholm C: Studies on the defect underlying the lysosomal storage of sialic acid in Salla disease. Lysosomal accumulation of sialic acid formed from N-acetyl-mannosamine or derived from low-density lipoprotein in cultured mutant fibroblasts. *J Clin Invest* 77:568, 1986.
233. Renlund M, Tietze F, Gahl WA: Defective sialic acid egress from isolated fibroblast lysosomes of patients with Salla disease. *Science* 232:759, 1986.
234. Reeves JP: Accumulation of amino acids by lysosomes incubated with amino acid methyl esters. *J Biol Chem* 254:8914, 1979.
235. Desjeux JF, Rajantie J, Simell O, Dumontier AM, Perheentupa J: Flux de lysine a travers l'epithelium du jejunum dans l'intolerance aux proteines avec lysinurie. *Gastroenterol Clin Biol* 4:31A, 1980.
236. Perheentupa J, Kekomaki M, Visakorpi JK: Studies on amino nitrogen metabolism in familial protein intolerance. *Pediatr Res* 4:209, 1970.
237. Ratner S: Urea synthesis and metabolism of arginine and citrulline. *Adv Enzymol* 15:319, 1954.
238. Meister A: Metabolism of glutamine. *Physiol Rev* 36:103, 1956.
239. Bachmann C, Colombo JP: Computer simulation of the urea cycle: Trials for an appropriate mode. *Enzyme* 26:259, 1981.
240. Krebs HA, Hems R, Lund P, Halliday D, Read WWC: Sources of ammonia for mammalian urea synthesis. *Biochem J* 176:733, 1978.
241. Stumph DA, Parks JK: Urea cycle regulation: I. Coupling of ornithine metabolism to mitochondrial oxidative phosphorylation. *Neurology* 30:178, 1980.
242. Natale PJ, Tremblay GC: On the availability of intramitochondrial carbamylphosphate for the extramitochondrial biosyntheses of pyrimidines. *Biochem Biophys Res Commun* 37:512, 1969.
243. Pausch J, Rasenack J, Haussinger D, Gerok W: Hepatic carbamoyl phosphate in de novo pyrimidine synthesis. *Eur J Biochem* 150:189, 1985.
244. Graham GG, MacLean WC Jr, Placko RP: Plasma free amino acids of infants and children consuming wheat-based diets, with and without supplemental casein or lysine. *J Nutr* 111:1446, 1981.
245. Cree TC, Schalch DS: Protein utilization in growth: Effect of lysine deficiency on serum growth hormone, somatomedins, insulin, total thyroxine [ $T_4$ ] and triiodothyronine, free  $T_4$  index, and total corticosterone. *Endocrinology* 117:667, 1985.
246. Borum PR, Broquist HP: Lysine deficiency and carnitine in male and female rats. *J Nutr* 107:1209, 1977.
247. Jansen GR: Lysine in human nutrition. *J Nutr* 76:1, 1962.
248. Hwang S-M, Segal S: Developmental and other characteristics of lysine uptake by rat brain synaptosomes. *Biochim Biophys Acta* 557:436, 1979.
249. Rajantie J, Simell O, Perheentupa J: Oral administration of  $\epsilon$ -N-acetyllysine and homocitrulline for lysinuric protein intolerance. *J Pediatr* 102:388, 1983.
250. Friedman M, Gumbmann MR: Bioavailability of some lysine derivatives in mice. *J Nutr* 111:1362, 1981.
251. Fujitaki JM, Steiner AW, Nichols SE, Helander ER, Lin YC, Smith RA: A simple preparation of N-phosphorylated lysine and arginine. *Prep Biochem* 10(2):205, 1980.
252. Morris JG, Rogers QR: Ammonia intoxication in the near-adult cat as a result of a dietary deficiency of arginine. *Science* 199:431, 1978.
253. Morris JG, Rogers QR: Arginine: An essential amino acid for the cat. *J Nutr* 108:1944, 1978.
254. Christensen HN: A transport system serving mono- and diamino acids. *Proc Natl Acad Sci U S A* 51:337, 1964.
255. Christensen HN, Handlogten M, Thomas EL:  $Na^+$  facilitated reactions of neutral amino acids with a cationic amino acid transport system. *Proc Natl Acad Sci U S A* 63:948, 1969.
256. Van Winkle LJ, Christensen HN, Campione AL:  $Na^+$ -dependent transport of basic, zwitterionic, and bicyclic amino acids by a broad-scope system in mouse blastocysts. *J Biol Chem* 260:12118, 1985.
257. Van Winkle LJ, Campione AL, Gorman JM:  $Na^+$ -independent transport of basic and zwitterionic amino acids in mouse blastocysts by a shared system and by processes which distinguish between these substrates. *J Biol Chem* 263:3150, 1988.
258. Kilberg MS, Stevens BR, Novak DA: Recent advances in mammalian amino acid transport. *Ann Rev Nutr* 13:137, 1993.
259. Metoki K, Hommes FA: The uptake of ornithine and lysine by isolated hepatocytes and fibroblasts. *Int J Biochem* 16:833, 1984.
260. Christensen HN: Role of amino acid transport and countertransport in nutrition and metabolism. *Physiol Rev* 70:43, 1990.
261. Albritton LM, Tseng L, Scadden D, Cunningham JM: A putative murine ecotropic retrovirus receptor gene encodes a multiple membrane-spanning protein and confers susceptibility to virus infection. *Cell* 57:659, 1989.
262. Hoffman W: Molecular characterization of the CAN1 locus in *Saccharomyces cerevisiae*. A transmembrane protein without N-terminal hydrophobic signal sequence. *J Biol Chem* 260:11831, 1985.
263. Tanaka J, Fink GR: The histidine permease gene (HIP1) of *Saccharomyces cerevisiae*. *Gene* 38:205, 1985.
264. Weber E, Chevallier M-R, Jund R: Evolutionary relationship and secondary structure predictions in four transport proteins of *Saccharomyces cerevisiae*. *J Mol Evol* 27:341, 1988.
265. Kim JW, Closs EI, Albritton LM, Cunningham JM: Transport of cationic amino acids by the mouse ecotropic retrovirus receptor. *Nature* 352:725, 1991.
266. Wang H, Kavanaugh MP, North RA, Kabat D: Cell-surface receptor for ecotropic murine retroviruses is a basic amino-acid transporter. *Nature* 352:729, 1991.
267. Closs EI, Albritton LM, Kim JW, Cunningham JM: Identification of a low affinity, high capacity transporter of cationic amino acids in mouse liver. *J Biol Chem* 268:7538, 1993.
268. Jaenisch R, Hoffman E: Transcription of endogenous C-type viruses in resting and proliferating tissues of BALB/Mo mouse. *Virology* 98:289, 1979.
269. MacLeod CL, Finley K, Kakuda D, Kozak CA, Wilkinson MF: Activated T cells express a novel gene on chromosome 8 that is closely related to the murine ecotropic retroviral receptor. *Mol Cell Biol* 10:3663, 1990.
270. Wells RG, Hediger MA: Cloning of a rat kidney cDNA that stimulates dibasic and neutral amino acid transport and has sequence similarity to glucosidases. *Proc Natl Acad Sci U S A* 89:5596, 1992.
271. Tate SS, Yan N, Udenfriend S: Expression cloning of a  $Na^+$ -independent neutral amino acid transporter from rat kidney. *Proc Natl Acad Sci U S A* 89:1, 1992.
272. Bertran J, Werner A, Moore ML, Stange G, Markovich D, Biber J, Testar X, Zorzano A, Palacin M, Murer H: Expression-cloning of a cDNA from rabbit kidney cortex that induces a single transport system for cysteine, dibasic, and neutral amino acids. *Proc Natl Acad Sci U S A* 89:5601, 1992.
273. Lee W-S, Wells RG, Sabbag RV, Mohandas TK, Hediger MA: Cloning and chromosomal localization of a human kidney cDNA involved in cystine, dibasic, and neutral amino acids transport. *J Clin Invest* 91:1959, 1993.
274. Bertran J, Magagnin S, Werner A, Markovich D, Biber J, Testar X, Zorzano A, Kuhn LC, Palacin M, Murer H: Stimulation of system  $y^+$ -like amino acid transport by the heavy chain of human 4F2 surface antigen in *Xenopus laevis* oocytes. *Proc Natl Acad Sci U S A* 89:5606, 1992.
275. Wells RG, Lee W-S, Kanai Y, Leiden JM, Hediger MA: The 4F2 antigen heavy chain induces uptake of neutral and dibasic amino acids in *Xenopus* oocytes. *J Biol Chem* 267:15285, 1992.
276. Kacser H, Burns JA: The molecular basis of dominance. *Genetics* 97:639, 1981.
277. Li-Chan E, Nakai S: Covalent attachment of N<sup>ε</sup>-acetyl lysine, N<sup>ε</sup>-benzylidene lysine, and threonine to wheat gluten for nutritional improvement. *J Food Sci* 45(3):514, 1980.
278. Dickinson JC, Rosenblom H, Hamilton PB: Ion exchange chromatography of the free amino acids in the plasma of the newborn infant. *Pediatrics* 36:2, 1965.

279. Scriver CR, Davies E: Endogenous renal clearance rates of free amino acids in prepubertal children. *Pediatrics* **36**:592, 1965.
280. Palacín M, Estévez R, Bertran J, Zorzano A: Molecular biology of mammalian plasma membrane amino acid transporters. *Physiol Rev* **78**:969, 1998.
281. Deves R, Boyd CA: Transporters for cationic amino acids in animal cells: Discovery, structure and function. *Physiol Rev* **78**:487, 1998.
282. Verrey F, Jack DL, Paulsen IT, Saier MH Jr, Pfeiffer R: New glycoprotein-associated amino acid transporters. *J Membr Biol* **172**:181, 1999.
283. Duval M, Fenneteau O, Doireau V, Faye A, Yotnda P, Drapier JC, Schlegel N, Sterkers G, de Baulny HO, Vilmer E: Intermittent hemophagocytic lymphohistiocytosis is a regular feature of lysinuric protein intolerance. *J Pediatr* **134**:236, 1999.
284. Bader-Meunier B, Perez N, Muller S: Treatment of hemophagocytic lymphohistiocytosis with cyclosporin A and steroids in a boy with lysinuria protein intolerance. *J Pediatr* **136**:134, 2000.
285. Duval M, de Baulny HO, Vilmer E: Reply. *J Pediatr* **136**:134, 2000.
286. Palacín M, Estévez R, Zorzano A: Cystinuria calls for heteromultimeric amino acid transporters. *Curr Opin Cell Biol* **10**:455, 1998.
287. Chillaron J, Estévez R, Samarzija I, Waldegger S, Testar X, Lang F, Zorzano A, Busch A, Palacín M: An intracellular trafficking defect in type I cystinuria rBAT mutants M467T and M467K. *J Biol Chem* **272**:9543, 1997.
288. Estévez R, Camps M, Rojas AM, Testar X, Deves R, Hediger MA, Zorzano A, Palacín M: The amino acid transport system  $y^+L/4F2hc$  is a heteromultimeric complex. *FASEB J* **12**:1319, 1998.
289. Mastrobardino L, Spindler B, Pfeiffer R, Skelly PJ, Loffing J, Shoemaker BC, Verrey F: Amino acid transport by heterodimers of 4F2hc/CD98 and members of a permease family. *Nature* **395**:288, 1998.
290. Torrents D, Estévez R, Pineda M, Fernández E, Lloberas J, Shi Y-B, Zorzano A, Palacín M: Identification and characterization of a membrane protein ( $y^+L$  amino acid transporter-1) that associates with 4F2hc to encode the amino acid transport activity  $y^+L$ . *J Biol Chem* **273**:32437, 1998.
291. Pfeiffer R, Rossier G, Spindler B, Meier C, Kühn L, Verrey F: Amino acid transport of  $y^+L$ -type by heterodimers of 4F2hc/CD98 and members of the glycoprotein-associated amino acid transporter family. *EMBO J* **18**:49, 1999.
292. Lauteala T, Sistonen P, Savontaus M-L, Mykkänen J, Simell J, Lukkarinen M, Simell O, Aula P: Lysinuric protein intolerance (LPI) gene maps to the long arm of chromosome 14. *Am J Hum Genet* **60**:1479, 1997.
293. Lauteala T, Mykkänen J, Sperandio MP, Gasparini P, Savontaus ML, Simell O, Andria G, Sebastio G, Aula P: Genetic homogeneity of lysinuric protein intolerance. *Eur J Hum Genet* **6**:612, 1998.
294. Torrents D, Mykkänen J, Pineda M, Feliubadaló L, Estévez R, de Cid R, Sanjurjo P, Zorzano A, Nunes V, Huoponen K, Reinikainen A, Simell O, Savontaus M-L, Aula P, Palacín M: Identification of SLC7A7, encoding  $y^+LAT-1$ , as the lysinuric protein intolerance gene. *Nat Genet* **21**:293, 1999.
295. Borsani G, Bassi MT, Sperandio MP, De Grandi A, Buoninconti A, Riboni M, Manzoni M, Incerti B, Pepe A, Andria G, Ballabio A, Sebastio G: SLC7A7, encoding a putative permease-related protein, is mutated in patients with lysinuric protein intolerance. *Nat Genet* **21**:297, 1999.
296. Mykkänen J, Torrents D, Pineda M, Camps M, Yoldi ME, Horelli-Kuitunen N, Huoponen K, Heinonen M, Oksanen J, Simell O, Savontaus M-L, Zorzano A, Palacín M, Aula P: Functional analysis of novel mutations in  $y^+LAT-1$  amino acid transporter gene causing lysinuric protein intolerance (LPI). *Hum Mol Genet* **9**:431, 2000.
297. Sperandio MP, Bassi MT, Riboni M, Parenti G, Buoninconti A, Manzoni M, Incerti B, Larocca MR, Di Rocco M, Strisciuglio P, Dianzani U, Parini R, Candito M, Endo F, Ballabio A, Andria G, Sebastio G, Borsani G: Structure of the SLC7A7 gene and mutational analysis of patients affected by lysinuric protein intolerance. *Am J Hum Genet* **66**:92, 2000.