

UNITED STATES PATENT AND TRADEMARK OFFICE

BEFORE THE PATENT TRIAL AND APPEAL BOARD

TWITTER, INC.
Petitioner

v.

YOUTOO TECHNOLOGIES, LLC
Patent Owner

U.S. Patent No. 8,601,506
Issued: Dec. 3, 2013
Application No.: 13/571,476
Filed: Aug. 10, 2012
Title: Content Creation and Distribution System

DECLARATION OF SCOTT BENNETT, Ph.D.

TWITTER, INC.
EXHIBIT 1012

TABLE OF CONTENTS

	Page
I. INTRODUCTION.....	3
II. BACKGROUND AND QUALIFICATIONS.....	3
III. PRELIMINARIES.....	5
IV. OPINIONS REGARDING INDIVIDUAL DOCUMENTS.....	11
V. ATTACHMENTS	15
VI. CONCLUSION	16

I, Scott Bennett, hereby declare under penalty of perjury:

I. INTRODUCTION

1. I have personal knowledge of the facts and opinions set forth in this declaration, I believe them to be true, and if called upon to do so, I would testify competently to them. I have been warned that willful false statements and the like are punishable by fine or imprisonment, or both.

2. I am a retired academic librarian working as a Managing Partner of the firm Prior Art Documentation LLC at 711 South Race Street, Urbana, IL, 61801-4132. Attached as Appendix A is a true and correct copy of my Curriculum Vitae describing my background and experience. Further information about my firm is available at www.priorartdocumentation.com.

3. I have been retained by Klarquist Sparkman LLP. to authenticate and establish the dates of public accessibility of certain documents in an *inter partes* review proceedings for U.S. Patent Nos. 8,464,304 and 8,601,506. For this service, I am being paid my usual hourly fee of \$88/hour. My compensation in no way depends on the substance of my testimony or the outcome of this proceeding.

II. BACKGROUND AND QUALIFICATIONS

4. I was previously employed as follows:
- University Librarian, Yale University, New Haven, CT., 1994-2001;

- Director, The Milton S. Eisenhower Library, The Johns Hopkins University, Baltimore, MD, 1989-1994;
- Assistant University Librarian for Collection Management, Northwestern University, Evanston, IL, 1981-1989;
- Instructor, Assistant, and Associate Professor of Library Administration, University of Illinois at Urbana-Champaign, Urbana, IL, 1974-1981; and
- Assistant Professor of English, University of Illinois at Urbana-Champaign, 1967-1974.

5. Over the course of my work as a librarian, professor of English, researcher, and author of nearly fifty scholarly papers and other publications, I have had extensive experience with cataloging records and online library management systems built around Machine-Readable Cataloging (MARC) standards. I also have substantial experience in authenticating printed documents and establishing the date when they were accessible to researchers.

6. In the course of more than fifty years of academic life, I have myself been an active researcher. I have collaborated with many individual researchers and, as a librarian, worked in the services of thousands of researchers at four prominent research universities. Members of my family are university researchers. Over the years, I have read some of the voluminous professional

literature on the information seeking behaviors of academic researchers. And as an educator, I have a broad knowledge of the ways in which students in a variety of disciplines learn to master the bibliographic resources used in their disciplines. In all of these ways, I have a general knowledge of how researchers work.

III. PRELIMINARIES

7. *Scope of this declaration.* I am not a lawyer and I am not rendering an opinion on the legal question of whether any particular document is, or is not, a “printed publication” under the law.

8. I am, however, rendering my expert opinion on the authenticity of the documents referenced herein and on when and how each of these documents was disseminated or otherwise made available to the extent that persons interested and ordinarily skilled in the subject matter or art, exercising reasonable diligence, could have located the documents before 25 January 2010.

9. *Materials considered.* In forming the opinions expressed in this declaration, I have reviewed the documents and attachments referenced herein. These materials are records created in the ordinary course of business by publishers, libraries, indexing services, and others. From my years of experience, I am familiar with the process for creating many of these records, and I know these records are created by people with knowledge of the information in the record. Further, these records are created with the expectation that researchers

and other members of the public will use them. All materials cited in this declaration and its attachments are of a type that experts in my field would reasonably rely upon and refer to in forming their opinions.

10. *Persons of ordinary skill in the art.* I am informed that the subject matter of this proceeding relates generally to network architecture and multimedia systems, including creating and distributing multimedia.

11. I have been informed by counsel that a “person of ordinary skill in the art at the time of the invention” is a hypothetical person who is presumed to be familiar with the relevant field and its literature at the time of the inventions. This hypothetical person is also a person of ordinary creativity, capable of understanding the scientific principles applicable to the pertinent field.

12. I am informed that persons of ordinary skill in this subject matter or art would have possessed a Bachelor’s degree in Computer Science, Electrical and/or Computer Engineering, or equivalent training, and (ii) approximately two years of experience in network architecture and multimedia systems, including creating and distributing multimedia. Lack of work experience would have been remedied by additional education, and vice versa..

13. It is my opinion that by at least the 1990s, such a person would have had access to a vast array of long-established print resources in electrical/computer engineering and computer science as well as to a rich and fast-

changing set of online resources providing indexing information, abstracts, and full text services for electrical/computer engineering and computer science.

14. *Library catalog records.* Some background on MARC formatted records, OCLC, WorldCat, and OCLC's Connexion is needed to understand the library catalog records discussed in this declaration.

15. Libraries world-wide use the MARC format for catalog records; this machine readable format was developed at the Library of Congress in the 1960s.

16. MARC formatted records provide a variety of subject access points based on the content of the document being cataloged. All may be found in the MARC Fields 6XX. For example, MARC Field 600 identifies personal names used as subjects and the MARC Field 650 identifies topical terms. A researcher might discover material relevant to his or her topic by a search using the terms employed in the MARC Fields 6XX.

17. The MARC Field 040, subfield a, identifies the library or other entity that created the original catalog record for a given document and transcribed it into machine readable form. The MARC Field 008 identifies the date when this first catalog record was entered on the file. This date persists in all subsequent uses of the first catalog record, although newly-created records for the same document, separate from the original record, will show a new date. It is not unusual to find multiple catalog records for the same document.

18. WorldCat is the world's largest public online catalog, maintained by the Online Computer Library Center, Inc., or OCLC, and built with the records created by the thousands of libraries that are members of OCLC. WorldCat provides a user-friendly interface for the public to use MARC records; it requires no knowledge of MARC tags and codes. WorldCat records appear in many different catalogs, including the Statewide Illinois Library Catalog. The date a given catalog record was created (corresponding to the MARC Field 008) appears in some detailed WorldCat records as the Date of Entry.

19. Whereas WorldCat records are very widely available, the availability of MARC formatted records varies from library to library.

20. When an OCLC participating institution acquires a document for which it finds no previously created record in OCLC, or when the institution chooses not to use an existing record, it creates a record for the document using OCLC's Connexion, the bibliographic system used by catalogers to create MARC records. Connexion automatically supplies the date of record creation in the MARC Field 008.

21. Once the MARC record is created by a cataloger at an OCLC participating member institution, it becomes available to other OCLC participating members in Connexion and also in WorldCat, where persons interested and

ordinarily skilled in the subject matter or art, exercising reasonable diligence, can locate it.

22. When a book has been cataloged, it will normally be made available to readers soon thereafter—normally within a few days or (at most) within a few weeks of cataloging.

23. *Internet Archive*. The Internet Archive is a non-profit digital library founded in 1996.

24. The Internet Archive maintains an archive of webpages collected from the Internet using software called a crawler. Crawlers automatically create a snapshot of webpages as they existed at a certain point in time. The WayBack Machine is an application created by the Internet Archive to search its archive of Web page URLs and to represent, graphically, the date of each crawler capture.

25. The Internet Archive, now with about 50 petabytes of data, collects only Web material that is publicly available. Some sites are “not archived because they were password protected, blocked by robots.txt, or otherwise inaccessible to our automated systems. Site owners might have also requested that their sites be excluded from the WayBack Machine” (see the WayBack Machine FAQ, https://archive.org/about/faqs.php#The_Wayback_Machine).

26. Many Internet Archive captures made by the WayBack Machine have a banner at the top with the capture date prominently displayed. Other dates when

captures of the same URL have been made are indicated to the right and left of the date provided in the banner. Some captures may lack this banner. In these latter cases, the URL for the capture begins with the identification of the Internet Archive page (e.g., <http://web.archive.org/web/>) followed by information that dates and time stamps the capture as follows: year in yyyy, month in mm, day in dd, time code in hh:mm:ss (e.g., 20041208081749, or 8 December 2004 at 8:17:49 a.m.). These elements are then followed by the URL of the original capture site.

27. *Indexing.* A researcher may discover material relevant to his or her topic in a variety of ways. One common means of discovery is to search for relevant information in an index of periodical and other publications. Having found relevant material, the researcher will then normally obtain it online, look for it in libraries, or purchase it from the publisher, a bookstore, a document delivery service, or other provider. Sometimes, the date of a document's public accessibility will involve both indexing and library date information. Date information for indexing entries is, however, often unavailable. This is especially true for online indices.

28. Indexing services use a wide variety of controlled vocabularies to provide subject access and other means of discovering the content of documents. The formats in which these access terms are presented vary from service to service.

29. Online indexing services commonly provide bibliographic information, abstracts, and full-text copies of the indexed publications, along with a list of the documents cited in the indexed publication. These services also often provide lists of publications that cite a given document. A citation of a document is evidence that the document was publicly available and in use by researchers no later than the publication date of the citing document.

30. Prominent indexing services include:

31. SPIE Digital Library. Produced by the International Society for Optical Engineering (originally the Society of Photographic Instrumentation Engineers), this data base includes the newsletters, journals, and conference proceedings of the organization. More than 400,000 articles make up the database with 18,000 new research papers added each year.

IV. OPINIONS REGARDING INDIVIDUAL DOCUMENTS

DOCUMENT 1. Janne Lahti et al., “A Mobile Phone-based Context-aware Video Management Application,” in Proceedings of SPIE 6074, Multimedia on Mobile Devices II, San Jose, CA., 15-19 January 2006, SPIE-IS&T, Vol. 6074, pp. 60740O-1 – 60740O-11.

1. Authentication

32. Document 1 is a conference paper by Janne Lahti and others presented at a conference on multimedia on mobile devices sponsored by the Society for Imaging Science and Technology (IS&T) and the International Society for Optical Engineering (SPIE). The conference was held on 15-19 January 2006 in San Jose,

CA. Conference proceedings, including Document 1, were published as the Proceedings of SPIE 6074, Multimedia on Mobile Devices II.

33. Attachment 1a is a true and correct copy of Document 1 (along with the Multimedia on Mobile Devices II title page, title page verso, and contents pages) from the Linda Hall Library. Attachment 1b is a true and correct copy of the Linda Hall Library catalog record, in MARC format, for Multimedia on Mobile Devices II.

34. Attachment 1a is in a condition that creates no suspicion about its authenticity. Specifically Document 1 (starting on p. 607400-1 of Document 1 copied Attachment 1a) is not missing any intermediate pages, the text on each page appears to flow seamlessly from one page to the next, and there are no visible alterations to the document. Attachment 1a was found within the custody of a library – a place where, if authentic, it would likely be found.

35. Document 1 is also readily available online. Attachment 1c is a true and correct copy of the SPIE Digital Library index record for Document 1. Attachment 1d is a true and accurate copy of Document 1 downloaded from the item record copied in Attachment 1c.

36. Based on finding copies of Document 1 both in a library and online, and on finding library catalog and online index records for Document 1, I conclude that Attachment 1a is an authentic copy of Document 1.

2. Public Accessibility

37. Attachment 1e is a true and correct copy of an Internet Archive capture, of 6 January 2006, of parts of the program for the 15-19 January 2006 SPIE/IS&T conference in San Jose, CA, available at http://web.archive.org/web/20060106073559/http://electronicimaging.org/program/06/EI06_final.pdf .

38. Document 1 entered the realm of public discourse on Tuesday 17 January 2006 when it was presented (as indicated on p. 59 of the program copied in Attachment 1e) at January 2006 SPIE/IS&T conference in San Jose. The scope of the conference is suggested by list of conference sessions (starting on p. 10 of the program copied in Attachment 1e) and the list of over 2,500 attendees (starting on p. 268 of the program copied in Attachment 1e).

39. I am informed by counsel that the January 2006 SPIE/IS&T conference in San Jose was a well know conference among the multimedia on mobile device community. Thus, it is my understanding that a person of ordinary skill interested in multimedia on mobile devices would have been independently aware of the January 2006 SPIE/IS&T conference in San Jose as a prominent forum for discussing such technologies.

40. Attachment 1f is a true and correct copy of the Statewide Illinois Library Catalog record for the proceedings of the January 2006 SPIE/IS&T

conference in San Jose, showing this publication is held by 24 libraries world-wide.

41. The verso of the title page for the proceedings of January 2006 SPIE/IS&T conference in San Jose (Attachment 1a) carries the information that “as of July 2006, papers in the Proceedings of SPIE are first published electronically in the SPIE Digital Library (www.spiedl.org) and subsequently in print and CD-ROM.”

42. Attachment 1c, the SPIE Digital Library index record for Document 1, indicates that the proceedings of the January 2006 SPIE/IS&T conference in San Jose was published on 10 February 2006.

43. Attachment 1b, the Linda Hall Library catalog record for the proceedings of the January 2006 SPIE/IS&T conference in San Jose, indicates in the MARC Field 040 that this record was first created at the Linda Hall Library (OCLC code = LHL). The MARC Field 008 indicates this catalog record was created on 28 March 2006.

44. Attachment 1g is a true and correct copy of an Internet Archive capture, dated 18 June 2006, of an IS&T and SPIE pre-publication notice of the availability of the proceedings of the January 2006 SPIE/IS&T conference in San Jose on CD-ROM. This announced publication includes SPIE Volumes 6055-6077, including Volume 6074 in which Document 1 was published.

45. I conclude that the proceedings of the January 2006 SPIE/IS&T conference in San Jose, including Document 1, was available online from its publisher on or about 10 February, shortly after the conference concluded. I conclude further that a print version of the January 2006 SPIE/IS&T conference in San Jose, including Document 1, was available in at least one library by mid-April 2006, while the CD-ROM publication of the proceedings of the January 2006 SPIE/IS&T conference in San Jose was publicly offered for sale by its publisher by no later than 18 June 2006..

3. Conclusion

46. Based on the evidence presented here—presentation at and publication in the proceedings of a prominent conference, library cataloging, and online indexing—it is my opinion that **Document 1 was publicly accessible online on or about 10 February 2006, was publicly accessible in print form in at least one library by mid-April 2006, and was publicly offered for sale by its publisher in CD-ROM form by no later than 18 June 2006.**

V. ATTACHMENTS

47. The attachments attached hereto are true and correct copies of the materials identified above. Helen Sullivan is a Managing Partner in Prior Art Documentation Services LLC (see <http://www.priorartdocumentation.com/hellen->

[sullivan/](#)). One of her primary responsibilities in our partnership is to secure the bibliographic documentation used in attachments to our declarations.

48. Ms. Sullivan and I work in close collaboration on the bibliographic documentation needed in each declaration. I will sometimes request specific bibliographic documents or, more rarely, secure them myself. In all cases, I have carefully reviewed the bibliographic documentation used in my declaration. My signature on the declaration indicates my full confidence in the authenticity, accuracy, and reliability of the bibliographic documentation used.

49. Each Attachment has been marked with an identifying label on the top of each page. However, no alterations other than these noted labels appear in these attachments, unless otherwise noted. All attachments were created on 28 February – 3 March 2017 and all URLs referenced in this declaration were available 3 March 2017.

VI. CONCLUSION

50. I reserve the right to supplement my opinions in the future to respond to any arguments that Patent Owner or its expert(s) may raise and to take into account new information as it becomes available to me.

51. I declare that all statements made herein of my knowledge are true, and that all statements made on information and belief are believed to be true, and that these statements were made with the knowledge that willful false statements

and the like so made are punishable by fine or imprisonment, or both, under
Section 1001 of Title 18 of the United States Code.

Executed this 20th day of March, 2017, in Urbana, Illinois.

A handwritten signature in blue ink that reads "Scott Bennett". The signature is written in a cursive style and is positioned above a horizontal line.

Scott Bennett

Appendix A

SCOTT BENNETT
Yale University Librarian Emeritus

711 South Race
Urbana, Illinois 61801-4132
2scottbb@gmail.com
217-367-9896

EMPLOYMENT

Retired, 2001. Retirement activities include:

- Managing Partner in Prior Art Documentation Services, LLC, 2015-. This firm provides documentation services to patent attorneys; more information is available at <http://www.priorartdocumentation.com>
- Consultant on library space design, 2004-. This consulting practice is rooted in a research, publication, and public speaking program conducted since I retired from Yale University in 2001. I have served more than 50 colleges and universities in the United States and abroad with projects ranging in likely cost from under \$50,000 to over \$100 million. More information is available at <http://www.libraryspaceplanning.com/>
- Senior Advisor for the library program of the **Council of Independent Colleges**, 2001-2009
- Member of the Wartburg College Library Advisory Board, 2004-
- Visiting Professor, Graduate School of Library and Information Science, **University of Illinois at Urbana-Champaign**, Fall 2003

University Librarian, **Yale University**, 1994-2001

Director, The Milton S. Eisenhower Library, **The Johns Hopkins University**, Baltimore, Maryland, 1989-1994

Assistant University Librarian for Collection Management, **Northwestern University**, Evanston, Illinois, 1981-1989

Instructor, Assistant and Associate Professor of Library Administration, **University of Illinois at Urbana-Champaign**, 1974-1981

Assistant Professor of English, **University of Illinois at Urbana-Champaign**, 1967-1974

Woodrow Wilson Teaching Intern, **St. Paul's College**, Lawrenceville, Virginia, 1964-1965

EDUCATION

University of Illinois, M.S., 1976 (Library Science)
Indiana University, M.A., 1966; Ph.D., 1967 (English)
Oberlin College, A.B. magna cum laude, 1960 (English)

HONORS AND AWARDS

Morningside College (Sioux City, IA) Doctor of Humane Letters, 2010

American Council of Learned Societies Fellowship, 1978-1979; Honorary Visiting Research Fellow, Victorian Studies Centre, **University of Leicester**, 1979; **University of Illinois** Summer Faculty Fellowship, 1969

Indiana University Dissertation Year Fellowship and an **Oberlin College** Haskell Fellowship, 1966-1967; **Woodrow Wilson** National Fellow, 1960-1961

PROFESSIONAL ACTIVITIES

American Association for the Advancement of Science: Project on Intellectual Property and Electronic Publishing in Science, 1999-2001

American Association of University Professors: University of Illinois at Urbana-Champaign Chapter Secretary and President, 1975-1978; Illinois Conference Vice President and President, 1978-1984; national Council, 1982-1985, Committee F, 1982-1986, Assembly of State Conferences Executive Committee, 1983-1986, and Committee H, 1997-2001 ; Northwestern University Chapter Secretary/Treasurer, 1985-1986

Association of American Universities: Member of the Research Libraries Task Force on Intellectual Property Rights in an Electronic Environment, 1993-1994, 1995-1996

Association of Research Libraries: Member of the Preservation Committee, 1990-1993; member of the Information Policy Committee, 1993-1995; member of the Working Group on Copyright, 1994-2001; member of the Research Library Leadership and Management Committee, 1999-2001; member of the Board of Directors, 1998-2000

Carnegie Mellon University: Member of the University Libraries Advisory Board, 1994

Center for Research Libraries: Program Committee, 1998-2000

Johns Hopkins University Press: Ex-officio member of the Editorial Board, 1990-1994; Co-director of Project Muse, 1994

Library Administration and Management Association, Public Relations Section, Friends of the Library Committee, 1977-1978

Oberlin College: Member of the Library Visiting Committee, 1990, and of the Steering Committee for the library's capital campaign, 1992-1993; President of the Library Friends, 1992-1993, 2004-2005; member, Friends of the Library Council, 2003-

Research Society for Victorian Periodicals: Executive Board, 1971-1983; Co-chairperson of the Executive Committee on Serials Bibliography, 1976-1982; President, 1977-1982

A Selected Edition of W.D. Howells (one of several editions sponsored by the MLA Center for Editions of American Authors): Associate Textual Editor, 1965-1970; Center for Editions of American Authors panel of textual experts, 1968-1970

Victorian Studies: Editorial Assistant and Managing Editor, 1962-1964

Wartburg College: member, National Advisory Board for the Vogel Library, 2004-

Some other activities: Member of the **Illinois State Library** Statewide Library and Archival Preservation Advisory Panel; member of the **Illinois State Archives** Advisory Board; member of a committee advising the **Illinois Board of Higher Education** on the cooperative management of research collections; chair of a major collaborative research project conducted by the **Research Libraries Group** with support from Conoco, Inc.; active advisor on behalf of the **Illinois Conference AAUP** to faculty and administrators on academic freedom and tenure matters in northern Illinois.

Delegate to **Maryland Governor's Conference on Libraries and Information Service**; principal in initiating state-wide preservation planning in Maryland; principal in an effort to widen the use of mass deacidification for the preservation of library materials through cooperative action by the **Association of Research Libraries** and the **Committee on Institutional Cooperation**; co-instigator of a campus-wide information service for **Johns Hopkins University**; initiated efforts with the **Enoch Pratt Free Library** to provide information services to Baltimore's Empowerment Zones; speaker or panelist on academic publishing, copyright, scholarly communication, national and regional preservation planning, mass deacidification.

Consultant for the **University of British Columbia** (1995), **Princeton University** (1996), **Modern Language Association**, (1995, 1996), **Library of Congress** (1997), **Center for Jewish History** (1998, 2000-), **National Research Council** (1998); Board of Directors for the **Digital Library Federation**, 1996-2001; accreditation visiting team at **Brandeis University** (1997); mentor for **Northern Exposure to Leadership** (1997); instructor and mentor for ARL's **Leadership and Career Development Program** (1999-2000)

At the **Northwestern University Library**, led in the creation of a preservation department and in the renovation of the renovation, for preservation purposes, of the Deering Library book stacks.

At the **Milton S. Eisenhower Library**, led the refocusing and vitalization of client-centered services; strategic planning and organizational restructuring for the library; building renovation planning. Successfully completed a \$5 million endowment campaign for the humanities collections and launched a \$27 million capital campaign for the library.

At the **Yale University Library**, participated widely in campus-space planning, university budget planning, information technology development, and the promotion of effective teaching and learning; for the library has exercised leadership in space planning and renovation, retrospective conversion of the card catalog, preservation, organizational development, recruitment of minority librarians, intellectual property and copyright issues, scholarly communication, document delivery services among libraries, and instruction in the use of information resources. Oversaw approximately \$70 million of library space renovation and construction. Was co-principal investigator for a grant to plan a digital archive for Elsevier Science.

Numerous to invitations speak at regional, national, and other professional meetings and at alumni meetings. Lectured and presented a series of seminars on library management at the **Yunnan University Library**, 2002. Participated in the 2005 International Roundtable for Library and Information Science sponsored by the **Kanazawa Institute of Technology** Library Center and the Council on Library and Information Resources.

PUBLICATIONS

“Putting Learning into Library Planning,” *portal: Libraries and the Academy*, 15, 2 (April 2015), 215-231.

“How librarians (and others!) love silos: Three stories from the field “ available at the Learning Spaces Collaboratory Web site, <http://www.pkallsc.org/>

“Learning Behaviors and Learning Spaces,” *portal: Libraries and the Academy*, 11, 3 (July 2011), 765-789.

“Libraries and Learning: A History of Paradigm Change,” *portal: Libraries and the Academy*, 9, 2 (April 2009), 181-197. Judged as the best article published in the 2009 volume of *portal*.

“The Information or the Learning Commons: Which Will We Have?” *Journal of Academic Librarianship*, 34 (May 2008), 183-185. One of the ten most-cited articles published in JAL, 2007-2011.

“Designing for Uncertainty: Three Approaches,” *Journal of Academic Librarianship*, 33 (2007), 165–179.

“Campus Cultures Fostering Information Literacy,” *portal: Libraries and the Academy*, 7 (2007), 147-167. Included in Library Instruction Round Table Top Twenty library instruction articles published in 2007

“Designing for Uncertainty: Three Approaches,” *Journal of Academic Librarianship*, 33 (2007), 165–179.

“First Questions for Designing Higher Education Learning Spaces,” *Journal of Academic Librarianship*, 33 (2007), 14-26.

“The Choice for Learning,” *Journal of Academic Librarianship*, 32 (2006), 3-13.

With Richard A. O’Connor, “The Power of Place in Learning,” *Planning for Higher Education*, 33 (June-August 2005), 28-30

“Righting the Balance,” in *Library as Place: Rethinking Roles, Rethinking Space* (Washington, DC: Council on Library and Information Resources, 2005), pp. 10-24

Libraries Designed for Learning (Washington, DC: Council on Library and Information Resources, 2003)

“The Golden Age of Libraries,” in *Proceedings of the International Conference on Academic Librarianship in the New Millennium: Roles, Trends, and Global Collaboration*, ed. Haipeng Li (Kunming: Yunnan University Press, 2002), pp. 13-21. This is a slightly different version of the following item.

“The Golden Age of Libraries,” *Journal of Academic Librarianship*, 24 (2001), 256-258

“Second Chances. An address . . . at the annual dinner of the Friends of the Oberlin College Library November 13 1999,” Friends of the Oberlin College Library, February 2000

“Authors’ Rights,” *The Journal of Electronic Publishing* (December 1999), <http://www.press.umich.edu/jep/05-02/bennett.html>

“Information-Based Productivity,” in *Technology and Scholarly Communication*, ed. Richard Ekman and Richard E. Quandt (Berkeley, 1999), pp. 73-94

“Just-In-Time Scholarly Monographs: or, Is There a Cavalry Bugle Call for Beleaguered Authors and Publishers?” *The Journal of Electronic Publishing* (September 1998), <http://www.press.umich.edu/jep/04-01/bennett.html>

“Re-engineering Scholarly Communication: Thoughts Addressed to Authors,” *Scholarly Publishing*, 27 (1996), 185-196

“The Copyright Challenge: Strengthening the Public Interest in the Digital Age,” *Library Journal*, 15 November 1994, pp. 34-37

“The Management of Intellectual Property,” *Computers in Libraries*, 14 (May 1994), 18-20

“Repositioning University Presses in Scholarly Communication,” *Journal of Scholarly Publishing*, 25 (1994), 243-248. Reprinted in *The Essential JSP. Critical Insights into the World of Scholarly Publishing. Volume 1: University Presses* (Toronto: University of Toronto Press, 2011), pp. 147-153

“Preservation and the Economic Investment Model,” in *Preservation Research and Development. Round Table Proceedings, September 28-29, 1992*, ed. Carrie Beyer (Washington, D.C.: Library of Congress, 1993), pp. 17-18

“Copyright and Innovation in Electronic Publishing: A Commentary,” *Journal of Academic Librarianship*, 19 (1993), 87-91; reprinted in condensed form in *Library Issues: Briefings for Faculty and Administrators*, 14 (September 1993)

with Nina Matheson, “Scholarly Articles: Valuable Commodities for Universities,” *Chronicle of Higher Education*, 27 May 1992, pp. B1-B3

“Strategies for Increasing [Preservation] Productivity,” *Minutes of the [119th] Meeting [of the Association of Research Libraries]* (Washington, D.C., 1992), pp. 39-40

“Management Issues: The Director’s Perspective,” and “Cooperative Approaches to Mass Deacidification: Mid-Atlantic Region,” in *A Roundtable on Mass Deacidification*, ed. Peter G. Sparks (Washington, D.C.: Association of Research Libraries, 1992), pp. 15-18, 54-55

“The Boat that Must Stay Afloat: Academic Libraries in Hard Times,” *Scholarly Publishing*, 23 (1992), 131-137

“Buying Time: An Alternative for the Preservation of Library Material,” *ACLS Newsletter*, Second Series 3 (Summer, 1991), 10-11

“The Golden Stain of Time: Preserving Victorian Periodicals” in *Investigating Victorian Journalism*, ed. Laurel Brake, Alex Jones, and Lionel Madden (London: Macmillan, 1990), pp. 166-183

“Commentary on the Stephens and Haley Papers” in *Coordinating Cooperative Collection Development: A National Perspective*, an issue of *Resource Sharing and Information Networks*, 2 (1985), 199-201

“The Editorial Character and Readership of *The Penny Magazine*: An Analysis,” *Victorian Periodicals Review*, 17 (1984), 127-141

“Current Initiatives and Issues in Collection Management,” *Journal of Academic Librarianship*, 10 (1984), 257-261; reprinted in *Library Lit: The Best of 85*

“Revolutions in Thought: Serial Publication and the Mass Market for Reading” in *The Victorian Periodical Press: Samplings and Soundings*, ed. Joanne Shattock and Michael Wolff (Leicester: Leicester University Press, 1982), pp. 225-257

“Victorian Newspaper Advertising: Counting What Counts,” *Publishing History*, 8 (1980), 5-18

“Library Friends: A Theoretical History” in *Organizing the Library’s Support: Donors, Volunteers, Friends*, ed. D.W. Krummel, Allerton Park Institute Number 25 (Urbana: University of Illinois Graduate School of Library Science, 1980), pp. 23-32

“The Learned Professor: being a brief account of a scholar [Harris Francis Fletcher] who asked for the Moon, and got it,” *Non Solus*, 7 (1980), 5-12

“Prolegomenon to Serials Bibliography: A Report to the [Research] Society [for Victorian Periodicals],” *Victorian Periodicals Review*, 12 (1979), 3-15

“The Bibliographic Control of Victorian Periodicals” in *Victorian Periodicals: A Guide to Research*, ed. J. Don Vann and Rosemary T. VanArsdel (New York: Modern Language Association, 1978), pp. 21-51

“John Murray’s Family Library and the Cheapening of Books in Early Nineteenth Century Britain,” *Studies in Bibliography*, 29 (1976), 139-166. Reprinted in Stephen Colclough and Alexis Weedon, eds., *The History of the Book in the West: 1800-1914*, Vol. 4 (Farnham, Surrey: Ashgate, 2010), pp. 307-334.

with Robert Carringer, “Dreiser to Sandburg: Three Unpublished Letters,” *Library Chronicle*, 40 (1976), 252-256

“David Douglas and the British Publication of W. D. Howells’ Works,” *Studies in Bibliography*, 25 (1972), 107-124

as primary editor, W. D. Howells, *Indian Summer* (Bloomington: Indiana University Press, 1971)

“The Profession of Authorship: Some Problems for Descriptive Bibliography” in *Research Methods in Librarianship: Historical and Bibliographic Methods in Library Research*, ed. Rolland E. Stevens (Urbana: University of Illinois Graduate School of Library Science, 1971), pp. 74-85

edited with Ronald Gottesman, *Art and Error: Modern Textual Editing* (Bloomington: Indiana University Press, 1970)--also published in London by Methuen, 1970

“Catholic Emancipation, the *Quarterly Review*, and Britain’s Constitutional Revolution,” *Victorian Studies*, 12 (1969), 283-304

as textual editor, W. D. Howells, *The Altrurian Romances* (Bloomington: Indiana University Press, 1968); introduction and annotation by Clara and Rudolf Kirk

as associate textual editor, W. D. Howells, *Their Wedding Journey* (Bloomington: Indiana University Press, 1968); introduction by John Reeves

“A Concealed Printing in W. D. Howells,” *Papers of the Bibliographic Society of America*, 61 (1967), 56-60

editor, *Non Solus*, A Publication of the University of Illinois Library Friends, 1974-1981

editor, Robert B. Downs Publication Fund, University of Illinois Library, 1975-1981

Reviews, short articles, etc. in *Victorian Studies*, *Journal of English and German Philology*, *Victorian Periodicals Newsletter*, *Collection Management*, *Nineteenth-Century Literature*, *College & Research Libraries*, *Scholarly Publishing Today*, *ARL Newsletter*, *Serials Review*, *Library Issues*, *S[ociety for] S[cholarly] P[ublishing] Newsletter*, and *Victorian Britain: An Encyclopedia*

LINDA HALL LIBRARY

5109 CHERRY STREET
KANSAS CITY, MISSOURI
64110-2498

PHONE (816) 363-4600
FAX: (816) 926-8785



C

2/27/17 DocServ #: 780826

9:04

Shelved as: QA76.575 .M846 2006

Location:

Title: Multimedia on Mobile Devices II,

Volume:

Issue:

Date:

Author: Lahti, J., et al

Article Title: A mobile-phone based context-aware video management application

Pages: 607401-12
Accept Non English? Yes

RUSH

SHIP TO:

049051
Attn: Helen Sullivan
Prior Art Documentation Services
711 So. Race Street
Urbana IL II 61801-4135
US

Fax: 2174465370
Phone: 2174465370
Ariel:
Email: helen@priorartdocs.com

Rush

ElecDel

LHL

This request complies with "Fair Use"

X #19.50
C

Max Cost:

Reference Number:

Account Number:

FEDEX Account Number:

Notes: Please copy from print only, cover, title page, verso, table of contents and article and any library date stamp available.

WEB

12

A Mobile Phone-based Context-aware Video Management Application

Janne Lahti, Marko Palola, Jari Korva, Utz Westermann*, Kostas Pentikousis and Paavo Pietarila

VTT Technical Research Centre of Finland, FI-90571 Oulu, Finland

e-mail: firstname.lastname@vtt.fi

* University of California, Irvine, CA 92697-3425, USA

e-mail: westermann@acm.org

ABSTRACT

We present a video management system comprising a video server and a mobile camera-phone application called MobiCon, which allows users to capture videos, annotate them with metadata, specify digital rights management (DRM) settings, upload the videos over the cellular network, and share them with others. Once stored in the video server, users can then search their personal video collection via a web interface, and watch the video clips using a wide range of terminals. We describe the MobiCon architecture, compare it with related work, provide an overview of the video server, and illustrate a typical user scenario from the point of capture to video sharing and video searching. Our work takes steps forward in advancing the mobile camera-phone from a video playback device to a video production tool. We summarize field trial results conducted in the area of Oulu, Finland, which demonstrate that users can master the application quickly, but are unwilling to perform extensive manual annotations. Based on the user trial results and our own experience, we present future development directions for MobiCon, in particular, and the video management architecture, in general.

Keywords: mobile camera phone application, mobile video management, video metadata and digital rights management

1. INTRODUCTION

Mobile phone manufacturers are increasingly adding new models with multimedia support and most modern medium- to high-end cell phones come with an integrated audio/video player, a camera to capture still and moving pictures, and some media editing software. The "coolness factor" fuels the popularity of mobile camera phones (MCP) and increases the volume of user-created media content. MCPs can record videos of up to several minutes, depending on the amount of memory available. Videos cannot be reasonably stored permanently on the mobile device due to the limited memory capacity available. Thus, users are in need of services that allow them to store their videos somewhere else, also because users want to create collections of their clips and share them with friends and relatives. Some will even opt for making part of their digital content available from a web site, or add it to their blog entries. Although none of these is news, nevertheless, there is very little automation in this process, and mobile applications for video management are not as commonplace as one might think despite the fact that MCPs have been on the market for quite some time.

The main problem of mobile content management is two-fold: how to automate permanent video clip storage, and how to do so in a way that is user-friendly, allows for easy clip lookups, and enables the user to share videos with others. Even though there are standardized ways to share videos over the cellular network, including the Multimedia Messaging Service (MMS) [1] and the upcoming IP Multimedia Subsystem (IMS) [2, 3], they must all be supported by the mobile operator, require infrastructure expenditures, and allow mainly for point-to-point video sharing. Moreover, a common characteristic of these services is that they do not include a solution for video management, and do not take full advantage of the context information available at the point of video capture. Our development effort takes a different approach and attempts to (a) enable the MCP to serve as an valuable video production tool in addition to being a video consumption channel, and (b) permit users to share videos with others irrespective of the level of network operator support for multimedia services.

Of course, one can argue that an MCP is not the ideal device for video management because of the limited CPU, memory and input/output capabilities, battery power consumptions considerations, and the diverse video formats and

other technologies supported by the operating system. On the other hand, a MCP application can assist users to describe a video by associating it with annotations about, for example, where and when a video clip was shot, and who should be able to access it. The MCP application may have at its disposal different kinds of context information including sensors, a GPS device, a calendar service, and other Internet resources. All these are valuable sources for metadata that can be used to characterize the digital object and possibly uniquely identify it. Metadata plays a critical role in managing video content to the extent that Sarvas *et al.* [4] argue that it is not possible to manage media content effectively without them. The value of the metadata is illustrated in the following section, which presents a typical scenario where the user captures a video clip, associates it with metadata, and later searches for this particular video within her collection using an Internet-connected desktop PC. This paper details a solution to the problems related to user-created media content and annotation, and addresses some issues pertaining to sharing and storing videos using MCPs, and the challenges presented to the mobile video management system. The rest of this paper is organized as follows. Sections 3 and 4 discuss the implementation objectives of such video management system, and its architecture, respectively. Section 5 summarizes the results of a real user field trial evaluation, and Section 6 presents our current work in progress along with some future directions, which address certain shortcomings found in the first generation of the system. Finally, Section 7 reviews related work, and Section 8 concludes the paper.

2. A TYPICAL USER SCENARIO

We exemplify the use of the mobile video management system with a scenario involving a tourist in a sightseeing tour. The aim in this section is to provide an overall understanding of how the system works, essentially a high-level user-centered view of the requirements, before presenting, in the following section, the main objectives.

Figure 1 portrays Alice while on vacation in Oulu, Finland. Alice spends some time walking around the city center area, visiting several attractions, when she notices the Oulu cathedral clock tower from a distance. After approaching the church, she uses her MCP to record a short video of the cathedral, its clock tower, and the surrounding area. Alice uses *MobiCon*, an MCP application, which allows her not only to capture the video, but also to upload it to a server and notify her friends about recent findings during her tour of Oulu.

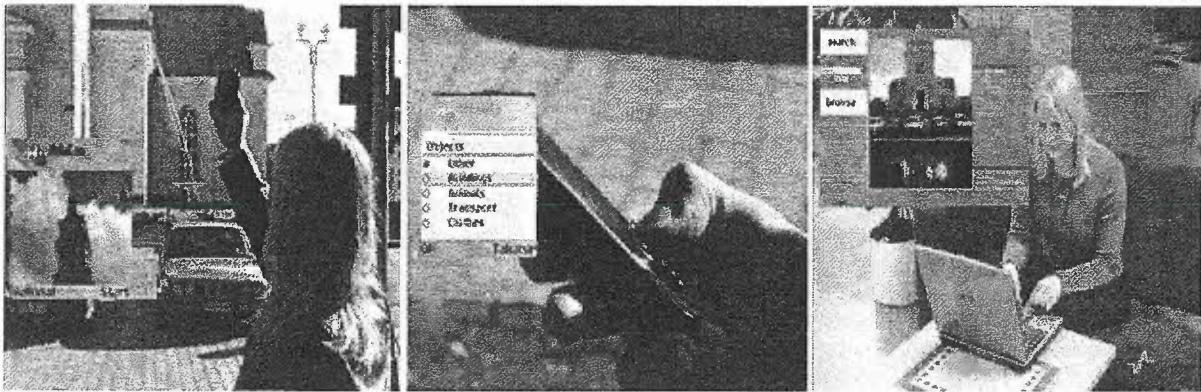

Figure 1: Alice records a video of the Oulu cathedral (left), annotates it with the term "Object > Buildings" (center), and later is able to search for it using the web interface of the Candela video management server (right).

After recording the video, Alice annotates it by selecting the predefined concepts "Holiday" and "Buildings" from the application metadata menu, and enters two keywords ("Church" and "Oulu") to describe the video clip more accurately. Alice saves the clip locally on the mobile phone memory card. Shortly afterwards, Alice decides to share the video with Bob, a friend of hers who is very interested in church architecture. With *MobiCon*, this is a simple process: Alice selects the video clip using a menu, chooses Bob from her contact list, and grants him the rights to watch the clip. She can subsequently upload the clip to the video server and *MobiCon* will automatically send a text message using the Short Message Service (SMS) to Bob with information on how to access the video. After receiving the text message, Bob can watch the video by opening its URL straight from his mobile phone.

After returning from her holidays, Alice can login to the video server using a web interface and access her large clip collection. Mobile videos tend to be short in length and relatively "focused" on a single theme. Unfortunately, Alice quickly finds herself having to deal with hundreds of videos with not-so-descriptive file names. Trying to locate the

“church video” in the entire collection can quickly become tiresome and this is where video metadata annotation proves helpful. Although Alice is not likely to remember the exact time or date that the video was captured or uploaded to the video server, she does remember where she was and what the main theme of the video was. Searching for “Oulu” limits the set of possible videos and searching for “church” narrows the size of the search result set to a handful of clips. Once located, Alice can watch the movie clip delivered by the video management server in the most appropriate format for her platform.

3. IMPLEMENTATION OBJECTIVES

A mobile video management application has five main functions: video recording, metadata annotation, video storage, video sharing, and locating video clips in a collection. Any MCP application, such as MobiCon, should be robust and rich in functionality, yet easy to use and engaging, despite the restrictions imposed by the small display size and minimal keyboard. Moreover, application developers must pay attention to the way resources are used: network traffic should be minimized, battery power should be conserved when possible, and CPU and memory ought to be utilized with frugality. These restrictions come on top of the classic mobile phone application development nightmares (device incompatibilities, network application debugging, immature SDKs, and different operating system versions with undocumented bugs) making the development of an application like MobiCon challenging.

Video *recording*, the first function, is relatively straightforward to implement with vendor provided SDKs. However, the application should be robust during this phase and capable of handling critical events (including incoming phone calls and text messages). As illustrated in the previous section, video *metadata annotation* is necessary for searching stored clips in an efficient manner and is a central part of the design of MobiCon. We can identify three main issues that need to be addressed: (a) when shall the application collect the metadata, (b) which types of metadata should be stored so that locating the video will be easier later, and (c) how can the application acquire all this information in an elegant and robust manner. Practice indicates that, at least for home videos, the best time to annotate video clips is right after capturing them. However, at this point it is difficult to predict which information will be most valuable in locating the video later on. For example, for a resident of Oulu using MobiCon frequently while in town, the term “Oulu” will not be a good choice in order to discriminate between a large set of videos. For Alice, though, the same term will allow her to easily select all videos from her last visit to Northern Finland. Thus, one can argue that the best choice is to collect as much information as possible, and preferably do so in an automated way. On the other hand, this may lead to generating mostly low-level data or content features, such as exact dates and color histograms, which are neither easily recollected by most humans nor convey a direct meaning to them. Therefore, the application must allow the user to provide additional high-level information, and assist him in this by making the process as easy as possible.

The limited phone resources make *video storage* and *video sharing* particularly interesting problems to address. Permanent storage cannot be provided by the phone in a scalable manner: compared to other kinds of mass storage devices, such as hard drives, memory cards for mobile phones are still expensive and very limited in capacity. Users typically end up transferring their videos to their PC and then share them with others. This, of course, is not a truly mobile video management solution. An MCP application should use the network to store the videos and allow others to view them in an asynchronous manner. For video sharing, there are no universally supported media formats, and the device capabilities and the capacity of the access networks vary greatly. Because of this, the original video ought to be provided in several alternative formats using different encoding parameters. However, video transcoding is a computationally demanding process which cannot be performed in real time. Thus, alternative versions should be generated before the video can be retrieved, typically soon after a clip is uploaded. Furthermore, an important aspect in video sharing is the ability to control how the receivers use the shared video clips and limit redistribution, if necessary. One way of handling the video storage and sharing is to place the videos on a server. This way the MCP application needs to upload the video only once while remaining able to share it with an arbitrary number of recipients. The server can also take care of all security and computational intensive aspects of video storage, and enable the user to *search* for video clips later. In short, by making an MCP application directly pluggable to a searchable repository that takes advantage of the captured metadata leads to avoiding time-consuming and inefficient lookups of video clips based on filenames and file dates alone.

To sum up these requirements, MobiCon should be able to capture video clips using the internal mobile phone camera, assist the user to annotate each clip with metadata, store the clip to a remote video management server, permit him to share video clips with others and, last but not least, enable him to search large collections of video clips using a mobile phone, PC, or any other device with web access. Users should maintain full control of the entire video management chain, from source to destination, by tapping on a standards-compliant digital rights management (DRM) framework.

4. SYSTEM ARCHITECTURE

The VTT Candela system, named after the European ITEA project CANDELA (Content Analysis, Networked Delivery and Architectures) was developed as a solution for general video management. It includes tools for video creation, analysis, annotation, storage, search and delivery phases. The Candela system was originally developed for the personal home video domain but, due to its modular and tiered architecture, it can be used as a basis for different video management applications by reusing some of the generic components and adding domain-specific ones. An important part of the entire architecture is the MCP application MobiCon, which can be used both on a standalone basis and as part of the entire system, as shown in Figure 2. Before delving in the details of the MobiCon architecture, we briefly introduce the Candela system; more details about the Candela architecture are given in [5, 6].

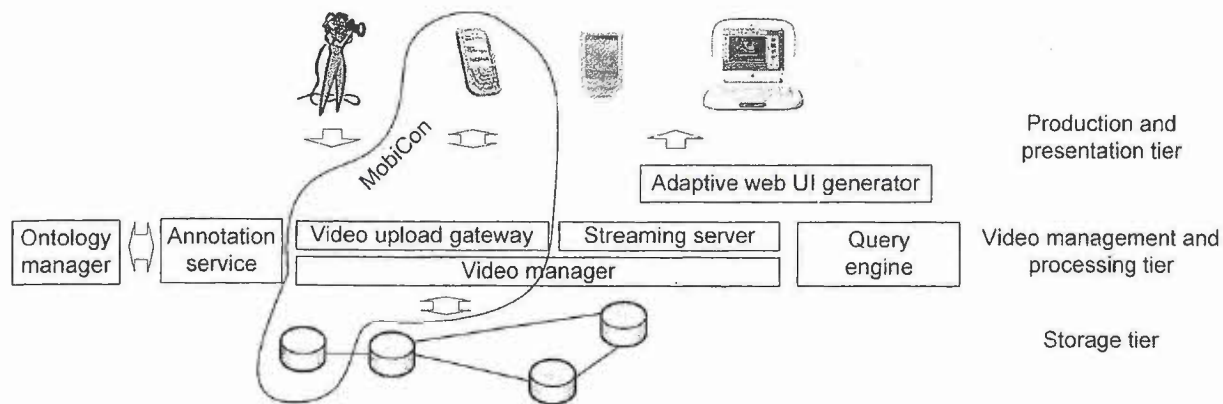

Figure 2: Candela and MobiCon system architecture.

4.1. Candela

Users can add video content to the Candela system produced by several different types of sources. The traditional method for home video content is to digitize analog content from a camcorder, or to use a digital one and upload the content to the system. Besides the home video domain, the Candela system can be a part of an enterprise-centered application such as, for example, an automatic security system handling the video content generated by a set of surveillance cameras. In the domain of personal mobile multimedia, the content is created in a mobile phone with video capture capabilities. In all application domains, the content is annotated automatically or semi-automatically, utilizing content analysis methods and input from sensors such as GPS positioning devices or context information which is available for example in a user's calendar. This information is captured in MPEG-7 metadata descriptions [7], which are stored along with the actual video data to support searching and managing video storage.

Candela uses the commercial Solid FlowEngine relational database system which provides scalability from a single in-memory database on a miniature embedded device to complex distributed and duplicated fault tolerant settings, which allows us to deploy more advanced configurations in the future. When storing, MPEG-7 descriptions are mapped to a relational schema so that SQL can be used for querying. In order to provide better results, the Candela query engine broadens user queries by suggesting additional search terms, which are, based on a domain ontology, closely related to the ones specified by the user or more descriptive. On the other hand, user profiles are used to restrict the amount of found matches to those that are the most relevant to the user.

Candela supports a very broad set of end user terminals ranging from cellular phones to high-end desktop computers. In order to provide a user friendly experience, the web-based interface dialogs are generated dynamically by using open source Apache Cocoon framework for XML transformations. This allows us to customize the amount of information presented to the user and the dialog between the user and the system to the capabilities of the used access device. Once the user has found an interesting video, a streaming video player is launched. This is either one of the off-the-self video players or Candela video browser which shows visualized metadata in addition to the video itself. The visualization allows the user to navigate through the video and find the relevant parts of it easily [5].

Providing optimal video quality for the end-user given the diversity of the source material, differences in user terminal capabilities and characteristics of networks, especially in the mobile domain, is a challenging task. MPEG-4

standard offers some scalable video coding solutions, where the changing network capabilities for video delivery can be taken into account in real-time by inserting enhancement layers to the video stream in case of more available bandwidth. However, it was concluded in the project that the state-of-the art in scalable video coding does not offer reasonable quality as compared to the non-scalable stream at the same bitrate [8].

If the media source is a mobile phone with a low resolution camera, the need for transcoding is not as obvious as for more bandwidth consuming content, but overall we want media to be accessible across platforms and at the moment there are no uniformly supported video formats. Thus the solution was, at the expense of storage, to transcode the material to a representative set of formats and bitrates and develop a content negotiation plug-in for Helix streaming server in order to choose from those.

4.2. MobiCon

The MobiCon client-server architecture is shown in Figure 3. MobiCon consists of two different software components: the UploadClient, which is a mobile Java (J2ME) application running on a mobile phone and UploadGateway, which is implemented as a Java servlet in the Candela server. Architecture is based on the need to provide wireless access over a mobile phone network to enable storing video clips on the server where it is also possible to run more computation-intensive operations such as video transcoding.

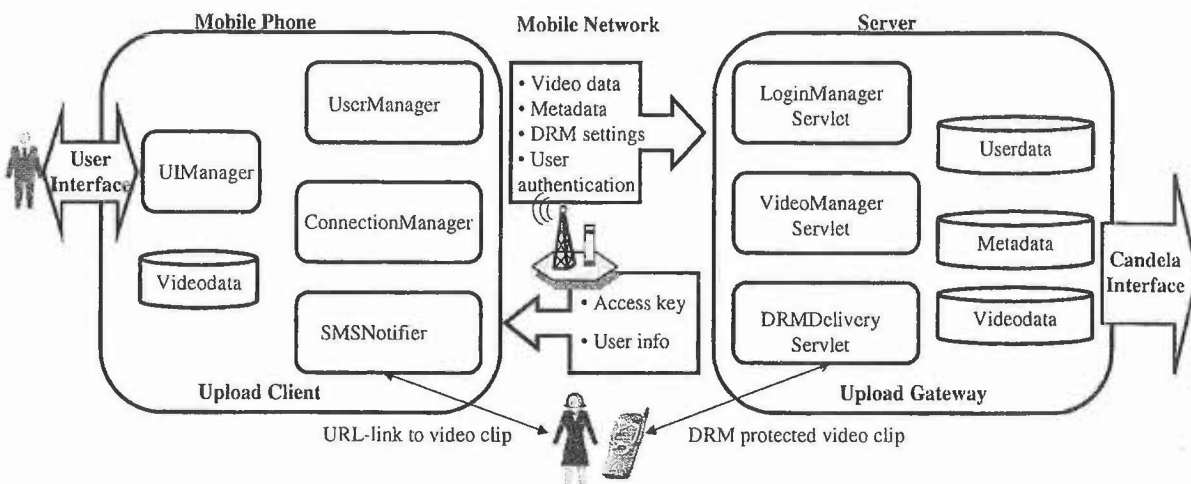

Figure 3: High-level description of MobiCon.

MobiCon naturally needs to be easily installed without any extra tools or additional instructions. The server allows distribution of MobiCon application easily to mobile phone users by using Over-The-Air (OTA) specification from the Open Mobile Alliance, which enables mobile applications to be downloaded and installed over the cellular network. After installation, the user is authenticated by the server using a username and password to log on the Candela system. The username and password are transferred to the UploadGateway and as a reply to successful authentication user profile information is transferred back to the UploadClient where UserManager stores user information (name, address, etc.), which are also used as metadata of captured video clips. The UploadClient no longer asks for username and password after the first time: for user convenience, it is assumed that the user stays the same after the first. Mobile phones are personal devices which are rarely lent to other people or left unguarded, the decision was made that the risk is not too large compared to the benefits achieved.

The UserManager is a controller component which is loaded first when the application is started. The UserManager coordinates the video capture using the mobile phone's camera, the saving of the video data to the Java Record Store system, and the sending of video sharing SMS messages to the other users. UserManager also provides user interfaces that are presented in the next Section. The ConnectionManager handles the connection between the UploadClient and UploadGateway providing data transfer using HTTP-protocol over the packet networks such as GPRS/EDGE/WCDMA. ConnectionManager delivers the captured video data, its metadata, user name, and DRM options to the Upload Gateway. If the user had chosen DRM protection for content sharing, the UploadGateway reply contains the identification keys to

be shared with another user. The ConnectionManager creates a URL containing the received identification keys and returns them to the UIManager, which sends them to the other users via the SMSNotifier.

The UploadGateway serves multiple MobiCon users and provides access to the Candela system. Figure 3 presents an architectural overview of the UploadGateway. The LoginManager servlet handles all the tasks needed for user authentication on the server side. The VideoManager servlet takes care of all the functionalities receiving video data from the UploadClient to the UploadGateway. The received video and metadata descriptions are stored temporarily, the video clip is transcoded, a key frame picture is extracted from the video, and metadata is finally formatted to the MPEG-7 XML format. All data including video clips, keyframes, and MPEG-7 are added to the database via Candela Interface.

The DRMDelivery servlet handles DRM video packaging and sharing. It is based on the Nokia Content Publishing Toolkit (NCPT) that allows creation of a DRM-protected video file package called Download Descriptor (DD), which holds the author, video name, size, and description. The DRMDelivery servlet creates a random number for DRM package name, which is delivered to other users in a URL address pointing to DRMDelivery servlet by SMS Notifier. The receiver of the shared video file needs only to open the URL link and to connect to DRMDelivery servlet using web browser in mobile phone and access the video clip if the DRM system in the mobile phone allows the access. The receiver can also see who the sender was and what kind of content is shared.

The MobiCon shared videos can be played directly via RealVideo player on mobile phone. With the DRM delivery channel a user can share video clips with other users who have a mobile phone supporting the OMA DRM standard and have a video player. DRM is an umbrella term for a set of technologies developed to protect against unauthorized copying and distribution of copyrighted material [9]. MobiCon is using DRM v1, although all mobile phones might not handle DRM protected content in standardized style [10].

4.3. MobiCon Interface Flow Diagrams

This section presents the MobiCon functionality from the user perspective with a walkthrough of typical usage scenarios. The user authentication and video capture is shown in Figure 4. The editing/uploading video clip is presented in Figure 5, which is expanded on Figure 6 and Figure 7 showing metadata annotation and DRM parameterization flows. Each figure comprises two parts: on the left side an Interface Flow Diagram [11] is given, while the right side presents the actual MCP screenshots.

User authentication and video capturing (Figure 4) starts with entering username and password for authentication with the server (Screenshots 1-2). If the username and password are valid, MobiCon receives the user's personal profile information and stores it in the phone memory. Then, MobiCon's main screen is displayed (Screenshot 3), where the user can choose to view and edit personal information, to load video clips, or to capture a new clip (Screenshot 4). A new video clip is captured in Capture Screen using Mobile Media API and it is recorded according to 3GPP specification using AMR coding for audio and H.263 at 176x144 pixels size at 15 frames per second for video. After a video is captured or loaded (Screenshot 5), the user is presented the Edit Screen (Screenshot 6) that ends the user authentication and video capturing scene.

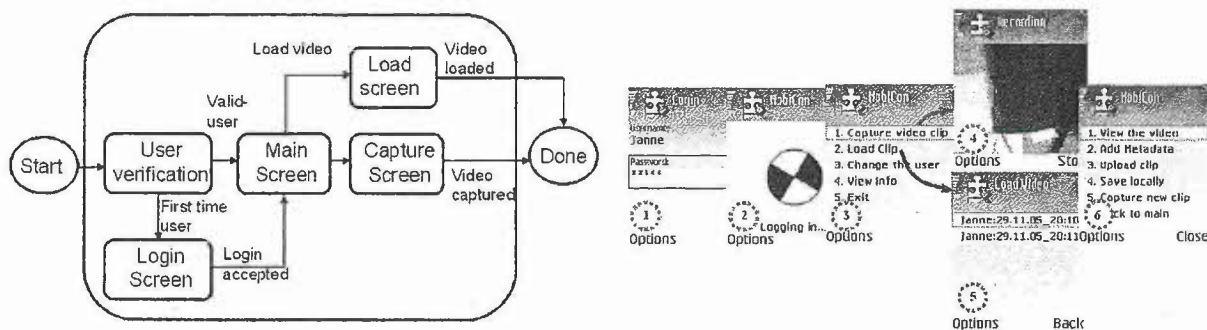

Figure 4: User authentication and video capturing: UI Flow Diagram (left) and UI screenshots (right).

Figure 5 presents the editing and uploading phase starting from the Edit Screen (Screenshot 1), which displays different editing options for the video clip. The user can choose to view the video clip in the Video View Screen (Screenshot 2), enter metadata annotations in the Metadata Screen (Screenshot 3), upload video clip (Screenshots 4, 5 and 6) either through the Access Screen or the DRM Screen, save, and capture a new video clip.

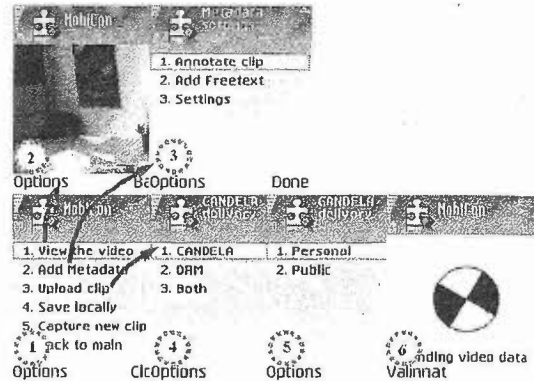
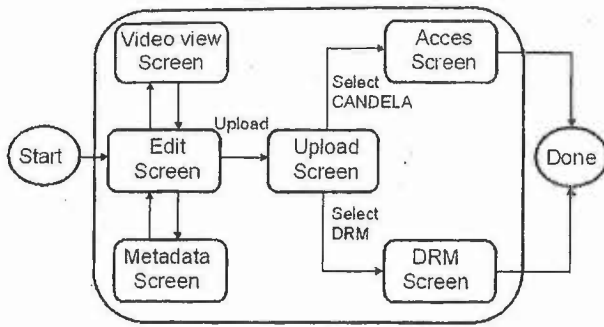

Figure 5: Editing and uploading the captured/loaded video clip: UI Flow Diagram (left) and UI screenshots (right).

In the Edit Screen, the user may choose to upload the clip to the Candela server. The Upload Screen (Screenshot 4) prompts the user to choose the Candela or the DRM delivery channel or both. If the user chooses Candela delivery channel the video clip is uploaded to Candela server over mobile phone network and added to the Candela video database, from where the user can later search and access the video clip. A user must also choose whether the video clip is only for personal use or whether other Candela users can also find the clip via search. This is selected in the Access Screen (Screenshot 5). Then the video clip is uploaded via the Upload Gateway to the user video collection on the Candela server (Screenshot 6). In the server the video clip is handed over to the Video Manager Servlet, which transcodes the video clip into different formats and bit rates in order to provide a scalable service quality for different devices and network connections. Currently, the Video Manager Servlet prepares Real Video, H.264, and H.263 encodings for delivering the captured video content to mobile devices and MPEG-4 file format for desktop computers. In the future, scalable video codecs will remove the need of transcoding [12]. The DRM delivery channel (Screenshot 4), to prepare video clip for DRM protected sharing, is presented in details in Figure 7. The functionalities under the Metadata screen (Screenshot 3) are presented in Figure 6, which illustrates the flow diagram for the metadata annotation phase.

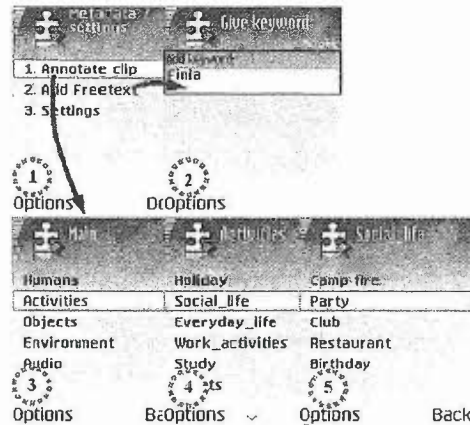
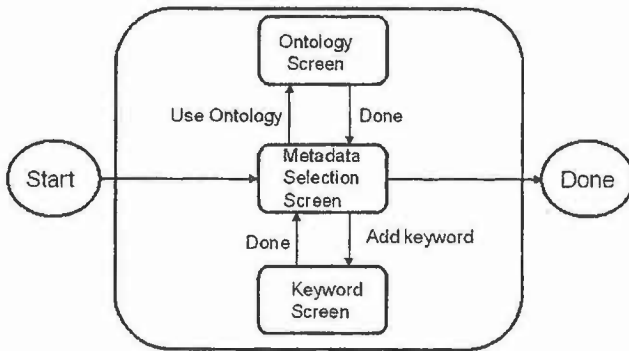

Figure 6: Giving metadata annotations: UI Flow Diagram (left) and UI screenshots (right).

The clip annotation starts from the Metadata Selection Screen (Screenshot 1) where the user has options to annotate clip using terms in a predefined domain ontology stored in the user's personal profile (Screenshots 3-5), add text descriptions by typing the nine-button keypad (Screenshot 2), and edit settings to update personal profile information, which is automatically added to the video clip metadata. When annotating via the Ontology Screen, the domain ontology can be accessed along a three-level hierarchical structure: the main level view (3) contains top-level concepts, which are then expanded in the sub-level menus (4, 5). All three levels are recorded to the clip. MobiCon also gathers context data that is available at the time of capture on the mobile phone such as user name, capture time, and duration of the clip. Additionally, MobiCon is able to connect to a GPS receiver supporting the NMEA protocol via Bluetooth. GPS provides

longitude and latitude coordinates and a timestamp for the metadata. All the video clip metadata is uploaded with the video clip. In the final MPEG-7 file the context data includes the creator's name, region and country, date and time of day, GPS information, and length of the video clip as well as terms given by user and from the ontology tree are embedded in free text annotation elements the MPEG-7 provides.

Figure 7 presents the flow diagram for the DRM protected sharing phase. The starting point is the Delivery Method Screen (Screenshot 1) where the user adds the DRM option. The user is prompted by possible recipients from the mobile phone's contacts list (Screenshot 2). After selecting a receiver, the user can select between two DRM protection methods: Forward-Lock and Combined-Delivery (Screenshot 3). The Forward-Lock method prevents the receiver from resending the shared video clip from their mobile phones and it does not require additional configuration. The Combined-Delivery method (Screenshot 4) is used to specify access rights for the shared video clip. With the Combined-Delivery method, the user can set the dates the receiver can watch the video and how many times the video can be played by the receiver (Screenshot 5). After completing the Rights Selection Screen, the UploadClient sends the video, metadata and DRM information to the UploadGateway, which creates a DRM package at the server side and returns one identification key for each receiver. As soon as Upload Client receives the key(s) it generates and sends SMS messages to the receivers, who can download and play the video clip without MobiCon client software.

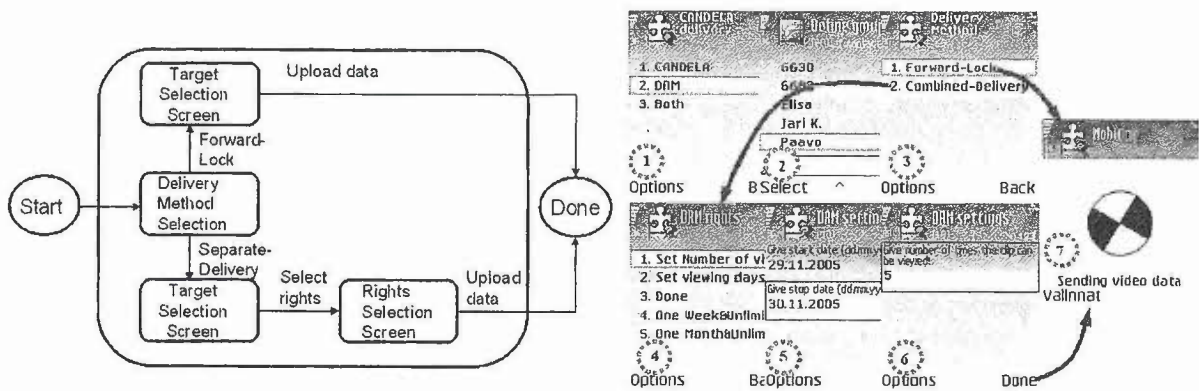

Figure 7: Sharing video DRM protected video clip: UI Flow Diagram (left) and UI screenshots (right).

5. FIELD TRIAL EVALUATION

Before initiating the field trial, MobiCon was tested extensively by a small group of developers/researchers from the Wireless Services group at VTT. Several issues were identified and fixed in the process, and we felt that both the application and the underlying video management service were ready for a field trial with real users. Due to space limitations, we will only summarize the results here; further details about the field trial are given in [13].

The main goal of the MobiCon field trial was to quantify application usability and assess its overall appeal to everyday users. The field trial lasted four weeks, starting on 14 February 2005. We lent each of the ten trial participants a Nokia 6630 MCP with MobiCon preinstalled. The primary author spent some time with each user introducing the application and explaining the main goals of the trial. At the end of the short tutorial, each participant had to take MobiCon for a "test ride" and continue using it for two weeks. Users were instructed to use the application as much as they would "in the real world". In other words, the aim of the trial was neither to stress- nor to beta-test MobiCon, but to replicate typical user behavior in a realistic environment; accordingly, participants were not forced to record, annotate, and upload as many videos as possible. During the trial period, we gathered data about the performance of the application and other context-related data, including user details, time and date; number of user interface (UI) selections made; session duration; type and number of metadata descriptions provided; and captured video duration, size, and upload bit rate. After the end of the trial period, users had to return the MCP and fill out an evaluation questionnaire.

The field trial results showed that MobiCon did overall meet all implementation objectives as specified in Section 3: users were able to capture video clips, annotate them with metadata, upload some of the clips to the video management server, and share clips with others. Both the application logs and the post-trial questionnaires indicated that MobiCon was relatively easy to use, even for inexperienced users. With regard to metadata annotation, most users agreed that an ontology-based term selection is a convenient way to add metadata to a clip, and it is preferred over free-text entries. Nevertheless, many users reported that the ontology tree structure and its size were far from ideal: some complained that

the ontology tree structure was “too large”, and that most terms were of little or no use; others wished the tree included more terms.

Despite the fact that most of the Oulu metropolitan area is covered by a fast 3G/UMTS network, seven out of ten users complained that the network was “slow”. Moreover, the field trial revealed other issues including a couple of bugs which led to application crashes, and the concerns raised by some of the less technologically savvy participants about the security-related questions frequently asked by the MCP operating systems. The latter was due to the fact that MobiCon was not a signed application at the time of the field trial; the former were fixed before the time of this writing.

By and large, the participants were very satisfied with MobiCon (as an MCP application) and are looking forward to using such a service when it becomes commercially available. Even so, the field trial participants suggested several improvements, which, along with our own experiences, guide the evolution to the next phase of development.

6. SYSTEM IMPROVEMENTS AND NEW DIRECTIONS

Given the outcome of the field trial evaluation, we saw the imperative need to ease the annotation process by automation. One approach towards this problem would be to apply content analysis techniques on the video clips. Extracting high-level annotations out of video content is already a challenging task in specialized domains with static and regular content such as sports or news [14, 15]. With home video clips shot with today's camera phones, however, the task is even more daunting: home video content is highly irregular and diverse reflecting the varying interests of people; the technical skills of home videographers are rather limited resulting in shaky and blurry content; the still limited resolutions of phone cameras as well as high compression losses contribute to the bad content quality.

These problems led us to the different and much simpler approach of inferring reasonable annotation suggestions out of the rich context data about the clip capture that is available on mobile phones, as recently also suggested by [16]. For example, suggestions about the time of day, month, and season can be easily derived out of the system time on the phone; information about location of a clip capture can be obtained from the current cell ID or – with more modern phones or a GPS receiver accessible via Bluetooth – even the GPS position; given the location, one may access the user's address book to find out whether the clip was captured at a known location; given the time, one can look up possibly documented events in a calendar; etc.

Following this idea, we created an annotation web service for the creation of context-based annotation suggestions [6] and integrated it into the Candela system as outlined by Figure 8. With the creation of this web service, we pursued several goals:

Firstly, an annotation web service was painless to integrate with the already existing MobiCon application. After video capture, MobiCon merely needs to create an HTTP request with the context data and add the returned suggestions to the list of annotation keywords.

The second goal is extensibility. As it is easy to come up with further ideas of how to generate reasonable suggestions out of context, we want to be able to flexibly integrate new annotation methods as they become available. Therefore, we implemented the annotation web service on top of a plug-n-play bus architecture, which facilitates rapid integration of new methods for the generation of annotation suggestions. In addition, a centralized web service eliminates the logistic problem of deploying new annotation methods on the mobile clients.

Thirdly, the generation of annotation suggestions on a server relieved us from concerns with regard to the computational complexity of the generation of annotation suggestions. The highly parallelized architecture of the annotation bus further contributes to that aspect: all annotation suggestions are generated in parallel threads minimizing response times for each request and maximizing server utilization.

Figure 8 illustrates overview to the bus architecture of the annotation web service with the different modules currently implemented for the generation of annotation suggestions based on initial annotation.

In addition to adding the context-aware annotation web service, we also improved manual annotation of video clips. Because of the user complaints in the field trial with regard to the suitability of the predefined domain ontology for annotation to their personal situation and interests, we re-designed the system such that every user – excluding some general concepts forming the upper level of the hierarchy – can modify the ontology concepts and structure. Users can thus optimize their ontologies to their individual annotation needs, such that they can reach the concepts important to them in few navigation steps and without having to scroll through many irrelevant concepts on a small phone display on the way.

The individual ontologies of users are managed by an ontology manager on the Candela server. When a user logs in to MobiCon, the application receives the personal ontology of the user from the ontology manager in RDF format and caches it for successive use along with the user's other profile data in the phone memory.

We also have made other minor improvements to annotations. Now, MobiCon memorizes that last five keyword entries of the user and offers them for fast selection.

We believe that all these improvements will enhance the Mobicon user experience, making it easier, for the user, to annotate the videos with metadata. But we also see it is necessary to verify these improvements with a new field trial in a near future.

We have also further improvement ideas to the annotation process, which we are planning to integrate to MobiCon; for example, an even better metadata collection method suiting the nature of phone device could be audio annotation, so the user could add metadata descriptions to the videos just by speaking. Also typing metadata annotations, with nine-button keypad, could be made easier by using dictionary assisted predictions for typed words.

With regard to the sharing of clips, MobiCon's current functionality is still limited, allowing the sharing of clips only right after capture. We are currently investigating the integration of a user interface into MobiCon that allows users to share any clip existing in their collections. In addition, the possibility of using other network connections, besides mobile networks, will be studied. Moreover, the remarks about slow cellular upload links, especially over GPRS, and the potential of high transfer fees in a public 3G network, prompted us to consider adding a peer-to-peer delivery channel as well. For example, users could connect to fixed networks by using network technologies like Bluetooth and WLAN, which can already be found on new mobile devices or they could use Bluetooth to share videos with user nearby. This is expected to satisfy a number of users who would prefer to capture several videos, annotate them on the spot, but upload them later.

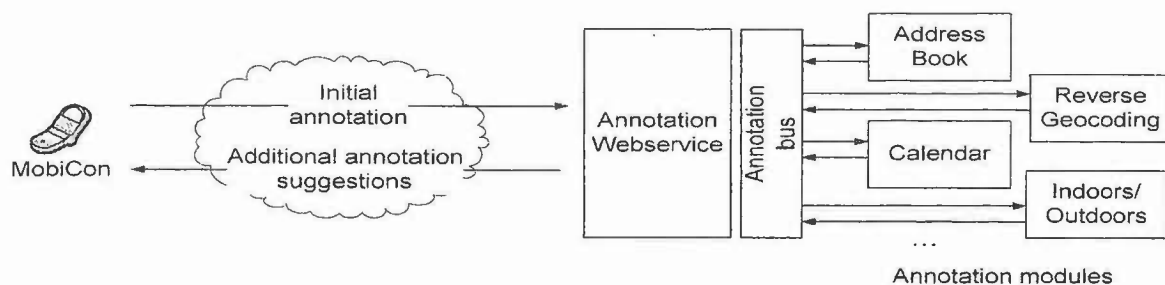

Figure 8: The Candela Annotation Web Service

7. RELATED WORK

Most of the existing mobile phone-based content management systems provide only capturing, annotating, and sharing of still photos, for example [4, 17]. Similar commercial applications as MobiCon exists such as Kodak Mobile (kodakmobile.com), Nokia's Movie Director (nokia.com), Nokia Album (nokia.com), and Nokia Lifeblog (nokia.com/lifeblog) and PhotoBlog (<http://www.futurice.fi/PhotoBlog.html>), but there is currently no similar mobile application that combines all video management features, i.e., video capturing, annotation using different context sources, sharing and storing videos for searching, into one [6, 13]. In general, existing commercial content sharing applications use different sharing methods such as MMS, email, blogs and even PC based tools for home personal video management [18].

Mobile video authoring applications exist for mobile phones without video sharing and DRM support, but they provide more advanced video editing tools in mobile device. For example, mProducer [19] provides video recording and editing in a mobile device, but it focuses on maximizing content capture space in a device and assisting the user in video editing, for example, by supporting shot detection and removing blurred frames. Video blogging using mobile devices is also becoming popular. FrameDrops [20] allows commenting captured video clips and provides video sharing via interactive web pages that align video clips over a map based on capture position. FrameDrops is targeted for work groups and online communities and they use Flash video format. MobiCon and Candela system targets personal video management by supporting video search in both mobile and desktop environments allowing sharing in different video formats.

Recent video annotation research is more focused on automatically summarizing video data from existing MPEG-7 video descriptions [21, 22] and enhancing the results using a query-based video personalization and summarization to show a shortened video summary of a large video content [23]. Also, some applications exist that automatically gather

video metadata from a specific type of video content, for example news broadcasts. IBM [23] has also developed system for creating personalized video content from video databases for PDA and PC users. We used similar technologies for example, MPEG-7 metadata files, but the main differences to MobiCon and video server are that we support DRM to control video redistribution, we only use high-level features (objects, person names, situation, address and town names) to annotate the video clips in MPEG-7 file and we need to transcode video clips for streaming both PC and mobile devices. We also did not implement shot boundary detection in MobiCon because mobile videos are short and they typically consist of a single shot. More about mobile video streaming can be found in [21].

A mobile network-based video sharing service is already commercially launching by mobile operators such as Telecom Italia Mobile and TLC in Hong Kong. In telecommunication networks, a video sharing service is based on IMS and it allows sharing real-time or pre-recorded video clips during normal voice calls using a separate data call. Both parties hear each other and watch the same video until they end the video sharing call [3]. MobiCon type of tools will benefit of IMS system, since IMS allows point-to-point access between mobile phones and it can replace SMS-based content delivery. MobiCon only uses a GPRS packet connection to transmit video data to video server and users are not point-to-point connected and sharing is not real-time. We expect that similar applications as MobiCon will be available also as IMS services managed by mobile operators.

Finally, other technologies such as sensors in mobile phone [19] and RFID tags and readers [24] will be available to provide alternative ways to users to access shared content.

8. CONCLUDING REMARKS

This paper introduced a video management solution, which has at its core MobiCon, a mobile camera phone application. We illustrated a typical scenario involving a tourist creating short videos while on a sightseeing tour, laid out our original implementation objectives, described the overall system architecture, and detailed the main features of the application using Interface Flow Diagrams and application screenshots. After summarizing the results of the first MobiCon field trial, we presented a set of improvements to the original implementation of the application, and gave a short account of our latest development efforts. Finally, this paper compared MobiCon with other related research and development efforts and pointed out significant differences, stating possible future directions.

Although MobiCon has reached a certain level of maturity, there are many issues that still remain to be tackled. Certain security concerns regarding video clip access for invited receivers, along with improvements on the digital rights management component, top the list. Once these have been addressed, the next step should be to open up the video management server to a larger group of users and allow them to use it in combination with MobiCon. This will permit us to evaluate the complete service under a much larger and diverse set of configurations, which ideally should include users in other countries and, hopefully, in other continents as well. Porting MobiCon to more platforms is also in our current plans, as is pursuing business development opportunities for we seek closer cooperation with mobile network operators and startup video management service providers in order to create a commercially-available turnkey solution. To that end, we are exploring alternative user scenarios, which are not restricted to the home video market segment. Finally, depending on user interest, we are considering adding support for short-range, peer-to-peer communication using Bluetooth and WiFi.

On the research front, we are exploring how content analysis methods can be integrated with the annotation web service. Although the system architecture has been designed to be extensible from the ground up, it is still not meaningful to implement annotation suggestion modules based on content analysis methods, because the video would have first to be uploaded and analyzed by the server in order for the annotation web service to provide suggestions. The resulting delay in the annotation process may be prohibitive. Perhaps the solution can come from a distributed version of the annotation bus, which allows us to keep annotation suggestion modules on the MCP. This will also address some privacy concerns arising from the need to have certain personal context data, such as address book contacts and calendar entries, transferred over the cellular network to the web service.

ACKNOWLEDGEMENTS

MobiCon and Candela were developed as part of the EUREKA/ITEA CANDELA (Content Analysis, Networked Delivery and Architectures) project during 2004-2005. Funding provided by TEKES National Technology Agency of Finland, and VTT Technical Research Centre of Finland is gratefully acknowledged.

REFERENCES

1. L. Novak and M. Svensson, "MMS - Building on the success of SMS", *Ericsson Review*, **78**(3), pp. 102–109, 2001.
2. J.F. Huber, "Toward the mobile Internet", *Computer*, **35**(10), pp. 100–102, 2002.
3. Nokia, "White Paper: Video Sharing v1.0", Forum Nokia, 2005.
4. R. Sarvas, E. Herrarte, A. Wilhelm, and M. Davis, "Metadata creation system for mobile images", *Proceedings of International Conference on Mobile Systems, Applications, and Services (ACM MobiSys)*, pp. 36–48, ACM Press, Boston, Massachusetts, USA, 2004.
5. A. Sachinopoulou, S.-M. Mäkelä, S. Järvinen, P. Pietarila, J. Peltola, and M. Jurvansuu, "Personal Video Retrieval and Browsing for Mobile Users", *Multimedia on Mobile Devices, Proceedings of SPIE-IS&T Electronic Imaging*, **5684**, pp. 219–230, 2005.
6. J. Lahti, U. Westermann, M. Palola, J. Peltola, and E. Vildjiounaite, "Context-Aware Mobile Capture and Sharing of Video Clips", *Handbook of Research on Mobile Multimedia*, I. K. Ibrahim & J. Kepler (eds.), Idea Group, Hershey, Pennsylvania, USA, 2006, to appear.
7. B. S. Manjunath, P. Salembier, and T. Sikora (Eds.), *Introduction to MPEG-7: Multimedia Content Description Language*, John Wiley & Sons, New York, New York, USA, 2002.
8. J. Vehkaperä and J. Peltola, "Optimized Decoding Scheme for Erroneous MPEG-4 FGS Bitstream", *Proc. of IEEE International Symposium on Circuits and Systems 2005 (ISCAS2005)*, Kobe, Japan, 2005.
9. W. Jonker and J.-P. Linnartz, "Digital Rights Management in Consumer Electronics Products", *IEEE Signal Processing Magazine*, **21**(2), pp. 82–91, 2004.
10. J. Irwin, "Digital Rights Management: The Open Mobile Alliance DRM specifications", *Information Security Technical Report*, **9**(4), pp. 22–31, 2004.
11. S. Ambler, *The Object Prime 3rd Edition, Agile Model Driven Development with UML 2*, Cambridge University Press, 2004.
12. A. Vetro, C. Christopoulos, and H. Sun, "Video transcoding architectures and techniques: An overview", *IEEE Signal Processing Magazine*, **20**(2), pp. 18–29, 2003.
13. J. Lahti, K. Pentikousis, and M. Palola, "MobiCon: Mobile video recording with integrated annotations and DRM", *Proceedings of IEEE Consumer Communications and Networking Conference (IEEE CCNC 2006)*, Las Vegas, Nevada, USA, 2006, to appear.
14. P. Duygulu, J. Pan, and D.A. Forsyth, "Towards Auto-Documentary: Tracking the Evolution of News Stories", *Proceedings of ACM Multimedia*, pp. 820–827, New York, New York, USA, 2004.
15. H. Xu and T. -S. Chua, "The Fusion of Audio-Visual Features and External Knowledge for Event Detection in Team Sports Video", *Proceedings of the 6th ACM SIGMM International Workshop on Multimedia Information Retrieval (MIR)*, pp. 127–134, New York, New York, USA, 2004.
16. M. Davis, S. King, N. Good, and R. Sarvas, "From Context to Content: Leveraging Context to Infer Multimedia Metadata", *Proceedings of ACM Multimedia*, pp. 188–195, New York, New York, USA, 2004.
17. M. Davis, "Mobile Media Metadata: Metadata Creation System for Mobile Images", *Proceedings of ACM Multimedia*, pp. 425–445, New York, New York, USA, 2004.
18. Y. Wang, P. Zhao, D. Zhang, M. Li, and H. Zhang, "MyVideos – A System for Home Video Management", *Proceedings of ACM Multimedia*, pp. 412–413, Juan Les Pins, France, 2002.
19. C.-M. Teng, C.-I. Wu, Y.-C. Chen, H. Chu, and J. Y. Hsu, "Design and Evaluation of mProducer: A mobile authoring tool for personal experience computing", *Proceedings of the third International Conference on Mobile and Ubiquitous Multimedia (MUM)*, pp. 141–148, College Park, Maryland, USA, 2004.
20. T. Gross and M. Kleppe, "FrameDrops: a mobile VideoBlog for workgroups and virtual communities", *Proceedings of International Conference on Supporting Group Work*, pp. 128–131, Sanibel Island, Florida, USA, 2005.
21. M. Etoh and S. Sekiguchi, "MPEG-7 enabled digest video streaming over 3G mobile network", *Proceedings of the 12th International PacketVideo Workshop*, Pittsburgh, Pennsylvania, USA, 2002.
22. P. M. Fonseca and F. Pereira, "Automatic video summarization based on MPEG-7", *Signal Processing: Image Communication*, **19**(8), pp. 685–699, 2004.
23. B. L. Tseng, C.-Y. Lin, and J. R. Smith, "Video personalization and summarization system for usage environment", *Journal of Visual Communication and Image Representation*, **15**(3), pp. 370–392, 2004.
24. Y.-M. Cheng, W. Yu, and T.-C. Chou, "Capturing context: Life is sharable: blogging life experience with RFID embedded mobile phones", *Proceedings of the 7th International Conference on Human Computer Interaction with Mobile Devices and Services (MobileHCI)*, pp. 295–298, Salzburg, Austria, 2005.

PROCEEDINGS OF
**Electronic
Imaging**
Science and Technology

Multimedia on Mobile Devices II

Reiner Creutzburg
Jarmo H. Takala
Chang Wen Chen
Chairs/Editors

16–17 January 2006
San Jose, California, USA

Sponsored by
IS&T—The Society for Imaging Science and Technology
SPIE—The International Society for Optical Engineering

SPIE Vol. 6074

0110.511

M846

2006

The papers included in this volume were part of the technical conference cited on the cover and title page. Papers were selected and subject to review by the editors and conference program committee. Some conference presentations may not be available for publication. The papers published in these proceedings reflect the work and thoughts of the authors and are published herein as submitted. The publishers are not responsible for the validity of the information or for any outcomes resulting from reliance thereon.

e-First Publication for Proceedings: As of July 2005, papers in the Proceedings of SPIE are first published electronically in the SPIE Digital Library (www.spiedl.org), and subsequently in print and CD-ROM.

Pagination system: The new citation format uses six-digit article identifier numbers (CIDs). Utilization of article CIDs allows proceedings articles to be fully citable as soon as they are published online, using the same identifier for both online and print versions.

The structure of the six-digit article CID number for Proceedings of SPIE is:

- The first four digits indicate the SPIE volume number.
- The last two digits indicate publication order within the volume using a Base 36 numbering system employing both numerals and letters. The CID number appears on each page, followed by the page number within the actual article.

Please use the following format to cite material from this book:

Author(s), "Title of Paper," in *Multimedia on Mobile Devices II*, edited by Reiner Creutzburg, Jarmo H. Takala, Chang Wen Chen, Proceedings of SPIE-IS&T Electronic Imaging, SPIE Vol. 6074, Article CID Number (2006).

ISSN 0277-786X
ISBN 0-8194-6114-8

Copublished by
SPIE—The International Society for Optical Engineering
P.O. Box 10, Bellingham, Washington 98227-0010 USA
Telephone 1 360/676-3290 (Pacific Time) · Fax 1 360/647-1445
<http://www.spie.org>

and
IS&T—The Society for Imaging Science and Technology
7003 Kilworth Lane, Springfield, Virginia, 22151 USA
Telephone 1 703/642-9090 (Eastern Time) · Fax 1 703/642-9094
<http://www.imaging.org>

Copyright © 2006, The Society of Photo-Optical Instrumentation Engineers and The Society for Imaging Science and Technology.

Copying of material in this book for internal or personal use, or for the internal or personal use of specific clients, beyond the fair use provisions granted by the U.S. Copyright Law is authorized by SPIE and IS&T subject to payment of copying fees. The Transactional Reporting Service base fee for this volume is \$15.00 per article (or portion thereof), which should be paid directly to the Copyright Clearance Center (CCC), 222 Rosewood Drive, Danvers, MA 01923. Payment may also be made electronically through CCC Online at <http://www.copyright.com>. Other copying for republication, resale, advertising or promotion, or any form of systematic or multiple reproduction of any material in this book is prohibited except with permission in writing from the publisher. The CCC fee code is 0277-786X/06/\$15.00.

Printed in the United States of America.

Contents

vii *Conference Committee*

INVITED PAPER I

- 607401 **New APIs for mobile graphics (Invited Paper) [6074-01]**
K. A. Pulli, Nokia Research Ctr. (USA) and Massachusetts Institute of Technology (USA)

MULTIMEDIA CODING I

- 607402 **A novel fast inter-prediction mode decision for H.264/AVC [6074-02]**
Y. Guo, H. Li, S. Pei, Univ. of Science and Technology of China (China); C. Chen, Florida Institute of Technology (USA)

MULTIMEDIA CODING II

- 607403 **Concealment driven bit rate reduction using the H.264 video coding standard [6074-03]**
S. T. C. Beesley, A. J. Armstrong, C. Grecos, D. J. Parish, Loughborough Univ. (United Kingdom)
- 607404 **Image embedded coding with edge preservation based on local variance analysis for mobile applications [6074-04]**
G. Luo, D. Osypiw, Buckinghamshire Chilterns Univ. College (United Kingdom)
- 607405 **Image coding using adaptive resizing in the block-DCT domain [6074-05]**
J. J. Koivusaari, J. H. Takala, M. Gabbouj, Tampere Univ. of Technology (Finland)
- 607406 **Spatial scalability of multiple ROIs in scalable video coding [6074-06]**
T. M. Bae, T. C. Thang, D. Y. Kim, Y. M. Ro, Information and Communications Univ. (South Korea); J.-G. Kim, Electronics and Telecommunications Research Institute (South Korea)

INVITED PAPER II

- 607407 **Implementing energy efficient embedded multimedia (Invited Paper) [6074-07]**
O. Silven, Univ. of Oulu (Finland); T. Rintaluoma, Hantro Products (Finland); K. Jyrkkä, Nokia Corp. (Finland)

MOBILE MULTIMEDIA RETRIEVAL AND CLASSIFICATION

- 607408 **A study of low-complexity tools for semantic classification of mobile video [6074-08]**
A. Mariappan, M. Igarfa, Purdue Univ. (USA); C. Taskiran, B. Gandhi, Motorola Labs. (USA); E. J. Delp, Purdue Univ. (USA)

iii

- 607409 **Audio-based queries for video retrieval over Java enabled mobile devices** [6074-09]
I. Ahmad, Nokia Corp. (Finland); F. A. Cheikh, S. Kiranyaz, M. Gabbouj, Tampere Univ. of Technology (Finland)

PROCESSORS FOR MULTIMEDIA

- 60740A **Parallel implementation of MPEG-2 video decoder** [6074-11]
A. Sarkar, North Carolina State Univ. (USA); K. Saha, S. Maiti, STMicroelectronics Pvt. Ltd. (India)
- 60740B **Software-based geometry operations for 3D computer graphics** [6074-12]
M. Sima, Univ. of Victoria (Canada); D. Iancu, Sandbridge Technologies, Inc. (USA); J. Glossner, Sandbridge Technologies, Inc. (USA) and Delft Univ. of Technology (Netherlands); M. Schulte, S. Mamidi, Univ. of Wisconsin/Madison (USA)
- 60740C **MVSP: multithreaded VLIW stream processor** [6074-13]
S. Sardashti, H. R. Ghasemi, O. Fatemi, Univ. of Tehran (Iran)
- 60740D **System-on-chip architecture with media DSP and RISC core for media application** [6074-14]
P. Liu, Zhejiang Univ. (China)
- 60740E **IIA: a novel method to optimize media instruction set of embedded processor** [6074-15]
K. Chen, G. Yu, P. Liu, Q. Yao, Zhejiang Univ. (China)

MULTIMEDIA APPLICATIONS I

- 60740G **Wireless steganography** [6074-18]
S. S. Agaian, D. Akopian, S. D'Souza, Univ. of Texas at San Antonio (USA)

MULTIMEDIA APPLICATIONS II

- 60740H **Image processing for navigation on a mobile embedded platform: Design of an autonomous mobile robot** [6074-19]
H. Loose, C. Lemke, C. Papazov, Brandenburg Univ. of Applied Sciences (Germany)
- 60740I **Image processing for navigation on a mobile embedded platform** [6074-20]
T. Preuss, L. Gentsch, M. Rambow, Univ. of Applied Sciences Brandenburg (Germany)
- 60740J **The future is ambient** [6074-21]
A. Lugmayr, Tampere Univ. of Technology (Finland)

MULTIMEDIA DATA MANAGEMENT

- 60740L **Performance analysis of MPEG-21 technologies on mobile devices** [6074-23]
S. De Zutter, F. De Keukeldere, C. Poppe, R. Van de Walle, Ghent Univ. (Belgium)

- 60740M **TV anytime and MPEG-21 DIA based seamless content mobility prototype system for digital home applications** [6074-24]
M. Kim, C. Yang, J. Lim, M. Kim, Information and Communications Univ. (South Korea);
S. Park, K. Kim, Y. Oh, Samsung Electronics Co., Ltd. (South Korea)
- 60740O **A mobile phone-based context-aware video management application** [6074-26]
J. Lahti, M. Palola, J. Korva, VTT Technical Research Ctr. of Finland (Finland);
U. Westermann, Univ. of California, Irvine (USA); K. Pentikousis, P. Pietarila, VTT Technical
Research Ctr. of Finland (Finland)

HCI ISSUES FOR MOBILE DEVICES

- 60740P **MIKE's PET: A participant-based experiment tracking tool for HCI practitioners using mobile devices** [6074-27]
D. Mohamedally, City Univ. London (United Kingdom); S. Edlich, E. Klaus, TFH-Berlin
(Germany); P. Zaphiris, City Univ. London (United Kingdom)
- 60740Q **Maintenance support: case study for a multimodal mobile user interface** [6074-28]
G. Fuchs, D. Reichart, H. Schumann, P. Forbrig, Univ. of Rostock (Germany)
- 60740R **Breaking the news on mobile TV: user requirements of a popular mobile content** [6074-29]
H. O. Knoche, M. A. Sasse, Univ. College London (United Kingdom)
- 60740S **Multimodal audio guide for museums and exhibitions** [6074-30]
S. Gebbensleben, J. Dittmann, C. Vielhauer, Otto-von-Guericke Univ. of Magdeburg
(Germany)
- 60740T **Human sound detection on experience movies** [6074-31]
S. Shimura, Y. Hirano, S. Kajita, K. Mase, Nagoya Univ. (Japan)

POSTER SESSION

- 60740U **A FGS coding method based on CI multiwavelet transform** [6074-34]
W. Liu, South China Normal Univ. (China)
- 60740V **A context-aware video display scheme for mobile devices** [6074-35]
K. Seo, C. Kim, Information and Communications Univ. (South Korea)
- 60740W **Verification of WIPI-based T-DMB platform for interactive mobile multimedia services**
[6074-36]
B. Bae, W. Kim, J. Yun, C. Ahn, S. I. Lee, Electronics and Telecommunications Research
Institute (South Korea); K.-I. Sohng, Kyungpook National Univ. (South Korea)
- 60740X **New TPEG applications based on digital multimedia broadcasting** [6074-37]
Y. Jeong, Electronics and Telecommunications Research Institute (South Korea) and
Chungnam National Univ. (South Korea); S. Cho, G. Kim, C. Ahn, S. Lee, Electronics and
Telecommunications Research Institute (South Korea); W. Kim, Chungnam National Univ.
(South Korea)

- 60740Z **An effective method and its implementation for splicing in terrestrial DMB** [6074-40]
Y. Lee, J. Lee, G. Lee, C. Ahn, S. I. Lee, Electronics and Telecommunications Research
Institute (South Korea); N. Kim, Chungbuk National Univ. (South Korea)
- 607410 **Media digital signal processor core design for multimedia application** [6074-42]
P. Liu, G. Yu, W. Cai, Q. Yao, Zhejiang Univ. (China)

Author Index



New Search:

Search

Search History

Multimedia on mobile devices II : 16-17 January, 2006, San Jose, California, USA /

- 000 01675nam a22003851a 4500
- 001 475357
- 005 20070521140600.0
- 008 060328s2006 waua b 101 0 eng d
- 020 _ |a 9780819461148
- 020 _ |a 0819461148
- 035 _ |a (OCoLC)65219184
- 035 _ |9 637336
- 040 _ |a LHL |c LHL
- 049 _ |a LHLA
- 090 _ |a QA76.575 |b .M646 2006
- 245 00 |a Multimedia on mobile devices II : |b 16-17 January, 2006, San Jose, California, USA / |c Reiner Creutzburg, Jarmo H. Takala, Chang Wen Chen, chairs/editors ; sponsored by IS & T--the Society for Imaging Science and Technology [and] SPIE--the International Society for Optical Engineering.
- 246 3_ |a Electronic imaging science and technology
- 260 _ |a Bellingham, Washington : |b SPIE ; |a Springfield, Virginia : |b IS&T, |c c2006.
- 300 _ |a 1 v. (various pagings) : |b ill. ; |c 28 cm.
- 490 1_ |a SPIE ; |v vol. 5684
- 500 _ |a At head of title: Proceedings of electronic imaging science and technology
- 504 _ |a Includes bibliographic references and author index.
- 650 _0 |a Multimedia systems |v Congresses
- 650 _0 |a Multimedia communications |v Congresses
- 650 _0 |a Multiprocessors |v Congresses
- 650 _0 |a Wireless communication systems |v Congresses
- 650 _0 |a Wireless communication systems
- 700 1_ |a Creutzburg, Reiner, |d 1953-
- 700 1_ |a Takala, Jarmo
- 700 1_ |a Chen, Chang Wen, |d 1959-
- 710 2_ |a IS & T--the Society for Imaging Science and Technology
- 710 2_ |a Society of Photo-optical Instrumentation Engineers
- 830 _0 |a Proceedings of SPIE--the International Society for Optical Engineering. |v v. 5684.
- 948 _ |a LTI 09/01/2008
- 994 _ |a C0 |b LHL

This Item
• [Record view](#)
• [Staff view](#)

Actions
• [Print](#)
• [Export](#)
• [E-mail](#)
• [Add to My List](#)

Google Books
["About This Book"](#)

A mobile phone-based context-aware video management application

Janne Lahti ; Marko Palola ; Jari Korva ; Utz Westermann ; Kostas Pentikousis ; Paavo Pietarila

[+] Author Affiliations

Proc. SPIE 6074, Multimedia on Mobile Devices II, 607400 (February 10, 2006); doi:10.1117/12.642204

Text Size: A 4 A

From Conference Volume 6074

Multimedia on Mobile Devices II
Reiner Creutzburg; Jarmo H. Takala; Chang Wen Chen
San Jose, CA | January 15, 2006

Abstract

abstract

We present a video management system comprising a video server and a mobile camera-phone application called MobiCon, which allows users to capture videos, annotate them with metadata, specify digital rights management (DRM) settings, upload the videos over the cellular network, and share them with others. Once stored in the video server, users can then search their personal video collection via a web interface, and watch the video clips using a wide range of terminals. We describe the MobiCon architecture, compare it with related work, provide an overview of the video server, and illustrate a typical user scenario from the point of capture to video sharing and video searching. Our work takes steps forward in advancing the mobile camera-phone from a video playback device to a video production tool. We summarize field trial results conducted in the area of Oulu, Finland, which demonstrate that users can master the application quickly, but are unwilling to perform extensive manual annotations. Based on the user trial results and our own experience, we present future development directions for MobiCon, in particular, and the video management architecture, in general.

© (2006) COPYRIGHT SPIE--The International Society for Optical Engineering. Downloading of the abstract is permitted for personal use only.

Full text of this article.

 Download pdf

Citation Janne Lahti ; Marko Palola ; Jari Korva ; Utz Westermann ; Kostas Pentikousis and Paavo Pietarila

"A mobile phone-based context-aware video management application", Proc. SPIE 6074, Multimedia on Mobile Devices II, 607400 (February 10, 2006); doi:10.1117/12.642204, <http://dx.doi.org.proxy2.library.illinois.edu/10.1117/12.642204>

Some tools below are only available to our subscribers or users with an online account.

 PDF  Email
 Share  Get Citation
 Article Alerts

Related Content

Customize your page view by dragging & repositioning the boxes below.

Related Proceedings Articles  11

Related Book Chapters  11

Topic Collections  11

Advertisement



Linear Stages
Fast voice coil

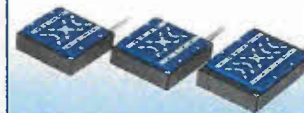

PI



Details 

SPIE CAREER CENTER

LAND THE
PERFECT JOB
IN OPTICS AND PHOTONICS





Site Map HOME PROCEEDINGS JOURNALS BOOKS TOPIC COLLECTION	Services Subscribe Work Information for Librarians Privacy Policy Terms of Use Contact Us About the Digital Library Help	Other Resources SPIE.org SPIE Membership SPIE Career Center	Information for Authors Books Journals Proceedings Resolving Permissions What's New in SPIE  
---	---	---	--



SPIE © 1962 - 2017 All Rights Reserved



A Mobile Phone-based Context-aware Video Management Application

Janne Lahti, Marko Palola, Jari Korva, Utz Westermann*, Kostas Pentikousis and Paavo Pietarila

VTT Technical Research Centre of Finland, FI-90571 Oulu, Finland
e-mail: firstname.lastname@vtt.fi

* University of California, Irvine, CA 92697-3425, USA
e-mail: westermann@acm.org

ABSTRACT

We present a video management system comprising a video server and a mobile camera-phone application called MobiCon, which allows users to capture videos, annotate them with metadata, specify digital rights management (DRM) settings, upload the videos over the cellular network, and share them with others. Once stored in the video server, users can then search their personal video collection via a web interface, and watch the video clips using a wide range of terminals. We describe the MobiCon architecture, compare it with related work, provide an overview of the video server, and illustrate a typical user scenario from the point of capture to video sharing and video searching. Our work takes steps forward in advancing the mobile camera-phone from a video playback device to a video production tool. We summarize field trial results conducted in the area of Oulu, Finland, which demonstrate that users can master the application quickly, but are unwilling to perform extensive manual annotations. Based on the user trial results and our own experience, we present future development directions for MobiCon, in particular, and the video management architecture, in general.

Keywords: mobile camera phone application, mobile video management, video metadata and digital rights management

1. INTRODUCTION

Mobile phone manufacturers are increasingly adding new models with multimedia support and most modern medium- to high-end cell phones come with an integrated audio/video player, a camera to capture still and moving pictures, and some media editing software. The “coolness factor” fuels the popularity of mobile camera phones (MCP) and increases the volume of user-created media content. MCPs can record videos of up to several minutes, depending on the amount of memory available. Videos cannot be reasonably stored permanently on the mobile device due to the limited memory capacity available. Thus, users are in need of services that allow them to store their videos somewhere else, also because users want to create collections of their clips and share them with friends and relatives. Some will even opt for making part of their digital content available from a web site, or add it to their blog entries. Although none of these is news, nevertheless, there is very little automation in this process, and mobile applications for video management are not as commonplace as one might think despite the fact that MCPs have been on the market for quite some time.

The main problem of mobile content management is two-fold: how to automate permanent video clip storage, and how to do so in a way that is user-friendly, allows for easy clip lookups, and enables the user to share videos with others. Even though there are standardized ways to share videos over the cellular network, including the Multimedia Messaging Service (MMS) [1] and the upcoming IP Multimedia Subsystem (IMS) [2, 3], they must all be supported by the mobile operator, require infrastructure expenditures, and allow mainly for point-to-point video sharing. Moreover, a common characteristic of these services is that they do not include a solution for video management, and do not take full advantage of the context information available at the point of video capture. Our development effort takes a different approach and attempts to (a) enable the MCP to serve as a valuable video production tool in addition to being a video consumption channel, and (b) permit users to share videos with others irrespective of the level of network operator support for multimedia services.

Of course, one can argue that an MCP is not the ideal device for video management because of the limited CPU, memory and input/output capabilities, battery power consumptions considerations, and the diverse video formats and

other technologies supported by the operating system. On the other hand, a MCP application can assist users to describe a video by associating it with annotations about, for example, where and when a video clip was shot, and who should be able to access it. The MCP application may have at its disposal different kinds of context information including sensors, a GPS device, a calendar service, and other Internet resources. All these are valuable sources for metadata that can be used to characterize the digital object and possibly uniquely identify it. Metadata plays a critical role in managing video content to the extent that Sarvas *et al.* [4] argue that it is not possible to manage media content effectively without them. The value of the metadata is illustrated in the following section, which presents a typical scenario where the user captures a video clip, associates it with metadata, and later searches for this particular video within her collection using an Internet-connected desktop PC. This paper details a solution to the problems related to user-created media content and annotation, and addresses some issues pertaining to sharing and storing videos using MCPs, and the challenges presented to the mobile video management system. The rest of this paper is organized as follows. Sections 3 and 4 discuss the implementation objectives of such video management system, and its architecture, respectively. Section 5 summarizes the results of a real user field trial evaluation, and Section 6 presents our current work in progress along with some future directions, which address certain shortcomings found in the first generation of the system. Finally, Section 7 reviews related work, and Section 8 concludes the paper.

2. A TYPICAL USER SCENARIO

We exemplify the use of the mobile video management system with a scenario involving a tourist in a sightseeing tour. The aim in this section is to provide an overall understanding of how the system works, essentially a high-level user-centered view of the requirements, before presenting, in the following section, the main objectives.

Figure 1 portrays Alice while on vacation in Oulu, Finland. Alice spends some time walking around the city center area, visiting several attractions, when she notices the Oulu cathedral clock tower from a distance. After approaching the church, she uses her MCP to record a short video of the cathedral, its clock tower, and the surrounding area. Alice uses MobiCon, an MCP application, which allows her not only to capture the video, but also to upload it to a server and notify her friends about recent findings during her tour of Oulu.



Figure 1: Alice records a video of the Oulu cathedral (left), annotates it with the term “Object > Buildings” (center), and later is able to search for it using the web interface of the Candela video management server (right).

After recording the video, Alice annotates it by selecting the predefined concepts “Holiday” and “Buildings” from the application metadata menu, and enters two keywords (“Church” and “Oulu”) to describe the video clip more accurately. Alice saves the clip locally on the mobile phone memory card. Shortly afterwards, Alice decides to share the video with Bob, a friend of hers who is very interested in church architecture. With MobiCon, this is a simple process: Alice selects the video clip using a menu, chooses Bob from her contact list, and grants him the rights to watch the clip. She can subsequently upload the clip to the video server and MobiCon will automatically send a text message using the Short Message Service (SMS) to Bob with information on how to access the video. After receiving the text message, Bob can watch the video by opening its URL straight from his mobile phone.

After returning from her holidays, Alice can login to the video server using a web interface and access her large clip collection. Mobile videos tend to be short in length and relatively “focused” on a single theme. Unfortunately, Alice quickly finds herself having to deal with hundreds of videos with not-so-descriptive file names. Trying to locate the

“church video” in the entire collection can quickly become tiresome and this is where video metadata annotation proves helpful. Although Alice is not likely to remember the exact time or date that the video was captured or uploaded to the video server, she does remember where she was and what the main theme of the video was. Searching for “Oulu” limits the set of possible videos and searching for “church” narrows the size of the search result set to a handful of clips. Once located, Alice can watch the movie clip delivered by the video management server in the most appropriate format for her platform.

3. IMPLEMENTATION OBJECTIVES

A mobile video management application has five main functions: video recording, metadata annotation, video storage, video sharing, and locating video clips in a collection. Any MCP application, such as MobiCon, should be robust and rich in functionality, yet easy to use and engaging, despite the restrictions imposed by the small display size and minimal keyboard. Moreover, application developers must pay attention to the way resources are used: network traffic should be minimized, battery power should be conserved when possible, and CPU and memory ought to be utilized with frugality. These restrictions come on top of the classic mobile phone application development nightmares (device incompatibilities, network application debugging, immature SDKs, and different operating system versions with undocumented bugs) making the development of an application like MobiCon challenging.

Video *recording*, the first function, is relatively straightforward to implement with vendor provided SDKs. However, the application should be robust during this phase and capable of handling critical events (including incoming phone calls and text messages). As illustrated in the previous section, video *metadata annotation* is necessary for searching stored clips in an efficient manner and is a central part of the design of MobiCon. We can identify three main issues that need to be addressed: (a) when shall the application collect the metadata, (b) which types of metadata should be stored so that locating the video will be easier later, and (c) how can the application acquire all this information in an elegant and robust manner. Practice indicates that, at least for home videos, the best time to annotate video clips is right after capturing them. However, at this point it is difficult to predict which information will be most valuable in locating the video later on. For example, for a resident of Oulu using MobiCon frequently while in town, the term “Oulu” will not be a good choice in order to discriminate between a large set of videos. For Alice, though, the same term will allow her to easily select all videos from her last visit to Northern Finland. Thus, one can argue that the best choice is to collect as much information as possible, and preferably do so in an automated way. On the other hand, this may lead to generating mostly low-level data or content features, such as exact dates and color histograms, which are neither easily recollected by most humans nor convey a direct meaning to them. Therefore, the application must allow the user to provide additional high-level information, and assist him in this by making the process as easy as possible.

The limited phone resources make *video storage* and *video sharing* particularly interesting problems to address. Permanent storage cannot be provided by the phone in a scalable manner: compared to other kinds of mass storage devices, such as hard drives, memory cards for mobile phones are still expensive and very limited in capacity. Users typically end up transferring their videos to their PC and then share them with others. This, of course, is not a truly mobile video management solution. An MCP application should use the network to store the videos and allow others to view them in an asynchronous manner. For video sharing, there are no universally supported media formats, and the device capabilities and the capacity of the access networks vary greatly. Because of this, the original video ought to be provided in several alternative formats using different encoding parameters. However, video transcoding is a computationally demanding process which cannot be performed in real time. Thus, alternative versions should be generated before the video can be retrieved, typically soon after a clip is uploaded. Furthermore, an important aspect in video sharing is the ability to control how the receivers use the shared video clips and limit redistribution, if necessary. One way of handling the video storage and sharing is to place the videos on a server. This way the MCP application needs to upload the video only once while remaining able to share it with an arbitrary number of recipients. The server can also take care of all security and computational intensive aspects of video storage, and enable the user to *search* for video clips later. In short, by making an MCP application directly pluggable to a searchable repository that takes advantage of the captured metadata leads to avoiding time-consuming and inefficient lookups of video clips based on filenames and file dates alone.

To sum up these requirements, MobiCon should be able to capture video clips using the internal mobile phone camera, assist the user to annotate each clip with metadata, store the clip to a remote video management server, permit him to share video clips with others and, last but not least, enable him to search large collections of video clips using a mobile phone, PC, or any other device with web access. Users should maintain full control of the entire video management chain, from source to destination, by tapping on a standards-compliant digital rights management (DRM) framework.

4. SYSTEM ARCHITECTURE

The VTT Candela system, named after the European ITEA project CANDELA (Content Analysis, Networked Delivery and Architectures) was developed as a solution for general video management. It includes tools for video creation, analysis, annotation, storage, search and delivery phases. The Candela system was originally developed for the personal home video domain but, due to its modular and tiered architecture, it can be used as a basis for different video management applications by reusing some of the generic components and adding domain-specific ones. An important part of the entire architecture is the MCP application MobiCon, which can be used both on a standalone basis and as part of the entire system, as shown in Figure 2. Before delving in the details of the MobiCon architecture, we briefly introduce the Candela system; more details about the Candela architecture are given in [5, 6].

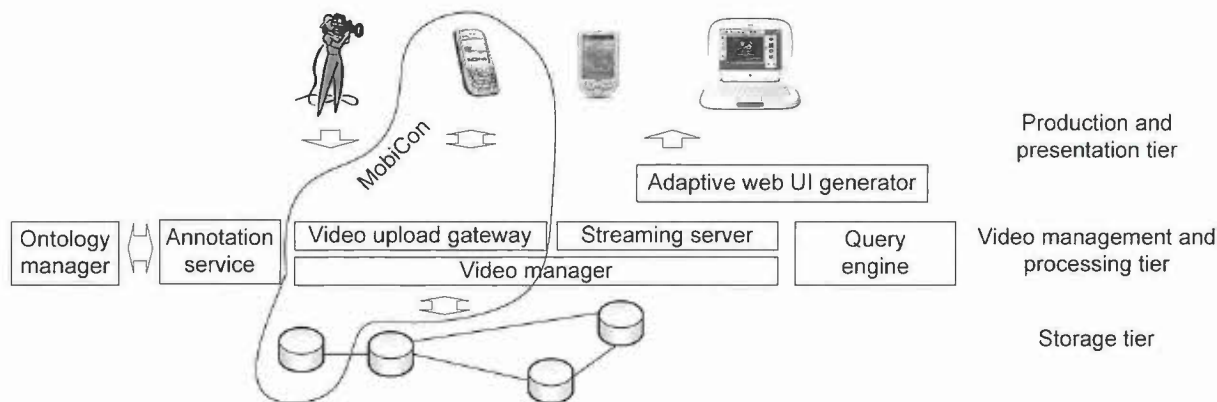

Figure 2: Candela and MobiCon system architecture.

4.1. Candela

Users can add video content to the Candela system produced by several different types of sources. The traditional method for home video content is to digitize analog content from a camcorder, or to use a digital one and upload the content to the system. Besides the home video domain, the Candela system can be a part of an enterprise-centered application such as, for example, an automatic security system handling the video content generated by a set of surveillance cameras. In the domain of personal mobile multimedia, the content is created in a mobile phone with video capture capabilities. In all application domains, the content is annotated automatically or semi-automatically, utilizing content analysis methods and input from sensors such as GPS positioning devices or context information which is available for example in a user's calendar. This information is captured in MPEG-7 metadata descriptions [7], which are stored along with the actual video data to support searching and managing video storage.

Candela uses the commercial Solid FlowEngine relational database system which provides scalability from a single in-memory database on a miniature embedded device to complex distributed and duplicated fault tolerant settings, which allows us to deploy more advanced configurations in the future. When storing, MPEG-7 descriptions are mapped to a relational schema so that SQL can be used for querying. In order to provide better results, the Candela query engine broadens user queries by suggesting additional search terms, which are, based on a domain ontology, closely related to the ones specified by the user or more descriptive. On the other hand, user profiles are used to restrict the amount of found matches to those that are the most relevant to the user.

Candela supports a very broad set of end user terminals ranging from cellular phones to high-end desktop computers. In order to provide a user friendly experience, the web-based interface dialogs are generated dynamically by using open source Apache Cocoon framework for XML transformations. This allows us to customize the amount of information presented to the user and the dialog between the user and the system to the capabilities of the used access device. Once the user has found an interesting video, a streaming video player is launched. This is either one of the off-the-self video players or Candela video browser which shows visualized metadata in addition to the video itself. The visualization allows the user to navigate through the video and find the relevant parts of it easily [5].

Providing optimal video quality for the end-user given the diversity of the source material, differences in user terminal capabilities and characteristics of networks, especially in the mobile domain, is a challenging task. MPEG-4

standard offers some scalable video coding solutions, where the changing network capabilities for video delivery can be taken into account in real-time by inserting enhancement layers to the video stream in case of more available bandwidth. However, it was concluded in the project that the state-of-the art in scalable video coding does not offer reasonable quality as compared to the non-scalable stream at the same bitrate [8].

If the media source is a mobile phone with a low resolution camera, the need for transcoding is not as obvious as for more bandwidth consuming content, but overall we want media to be accessible across platforms and at the moment there are no uniformly supported video formats. Thus the solution was, at the expense of storage, to transcode the material to a representative set of formats and bitrates and develop a content negotiation plug-in for Helix streaming server in order to choose from those.

4.2. MobiCon

The MobiCon client-server architecture is shown in Figure 3. MobiCon consists of two different software components: the UploadClient, which is a mobile Java (J2ME) application running on a mobile phone and UploadGateway, which is implemented as a Java servlet in the Candela server. Architecture is based on the need to provide wireless access over a mobile phone network to enable storing video clips on the server where it is also possible to run more computation-intensive operations such as video transcoding.

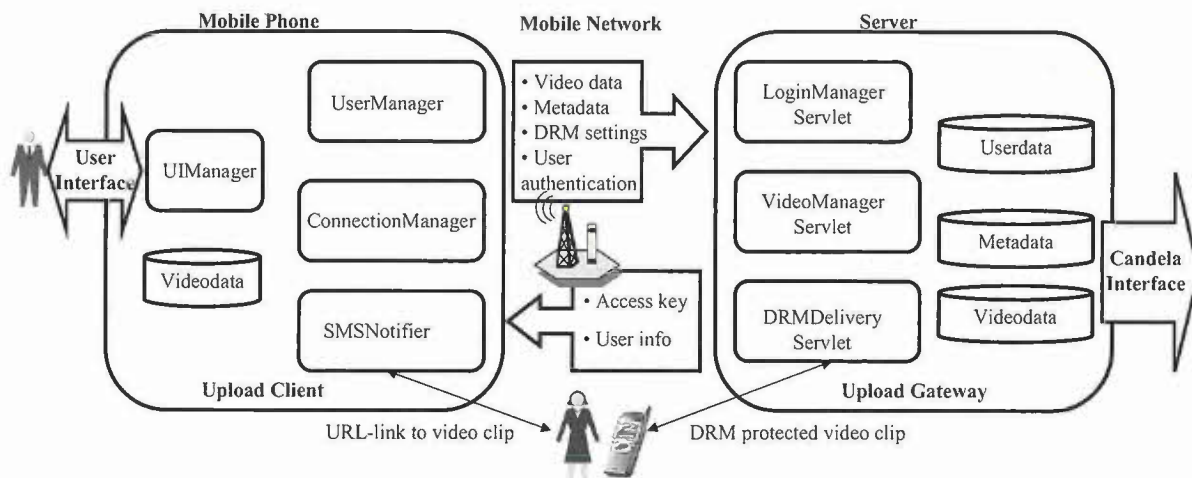

Figure 3: High-level description of MobiCon.

MobiCon naturally needs to be easily installed without any extra tools or additional instructions. The server allows distribution of MobiCon application easily to mobile phone users by using Over-The-Air (OTA) specification from the Open Mobile Alliance, which enables mobile applications to be downloaded and installed over the cellular network. After installation, the user is authenticated by the server using a username and password to log on the Candela system. The username and password are transferred to the UploadGateway and as a reply to successful authentication user profile information is transferred back to the UploadClient where UserManager stores user information (name, address, etc.), which are also used as metadata of captured video clips. The UploadClient no longer asks for username and password after the first time: for user convenience, it is assumed that the user stays the same after the first. Mobile phones are personal devices which are rarely lent to other people or left unguarded, the decision was made that the risk is not too large compared to the benefits achieved.

The UserManager is a controller component which is loaded first when the application is started. The UserManager coordinates the video capture using the mobile phone's camera, the saving of the video data to the Java Record Store system, and the sending of video sharing SMS messages to the other users. UserManager also provides user interfaces that are presented in the next Section. The ConnectionManager handles the connection between the UploadClient and UploadGateway providing data transfer using HTTP-protocol over the packet networks such as GPRS/EDGE/WCDMA. ConnectionManager delivers the captured video data, its metadata, user name, and DRM options to the Upload Gateway. If the user had chosen DRM protection for content sharing, the UploadGateway reply contains the identification keys to

be shared with another user. The ConnectionManager creates a URL containing the received identification keys and returns them to the UIManager, which sends them to the other users via the SMSNotifier.

The UploadGateway serves multiple MobiCon users and provides access to the Candela system. Figure 3 presents an architectural overview of the UploadGateway. The LoginManager servlet handles all the tasks needed for user authentication on the server side. The VideoManager servlet takes care of all the functionalities receiving video data from the UploadClient to the UploadGateway. The received video and metadata descriptions are stored temporarily, the video clip is transcoded, a key frame picture is extracted from the video, and metadata is finally formatted to the MPEG-7 XML format. All data including video clips, keyframes, and MPEG-7 are added to the database via Candela Interface.

The DRMDelivery servlet handles DRM video packaging and sharing. It is based on the Nokia Content Publishing Toolkit (NCPT) that allows creation of a DRM-protected video file package called Download Descriptor (DD), which holds the author, video name, size, and description. The DRMDelivery servlet creates a random number for DRM package name, which is delivered to other users in a URL address pointing to DRMDelivery servlet by SMS Notifier. The receiver of the shared video file needs only to open the URL link and to connect to DRMDelivery servlet using web browser in mobile phone and access the video clip if the DRM system in the mobile phone allows the access. The receiver can also see who the sender was and what kind of content is shared.

The MobiCon shared videos can be played directly via RealVideo player on mobile phone. With the DRM delivery channel a user can share video clips with other users who have a mobile phone supporting the OMA DRM standard and have a video player. DRM is an umbrella term for a set of technologies developed to protect against unauthorized copying and distribution of copyrighted material [9]. MobiCon is using DRM v1, although all mobile phones might not handle DRM protected content in standardized style [10].

4.3. MobiCon Interface Flow Diagrams

This section presents the MobiCon functionality from the user perspective with a walkthrough of typical usage scenarios. The user authentication and video capture is shown in Figure 4. The editing/uploading video clip is presented in Figure 5, which is expanded on Figure 6 and Figure 7 showing metadata annotation and DRM parameterization flows. Each figure comprises two parts: on the left side an Interface Flow Diagram [11] is given, while the right side presents the actual MCP screenshots.

User authentication and video capturing (Figure 4) starts with entering username and password for authentication with the server (Screenshots 1-2). If the username and password are valid, MobiCon receives the user's personal profile information and stores it in the phone memory. Then, MobiCon's main screen is displayed (Screenshot 3), where the user can choose to view and edit personal information, to load video clips, or to capture a new clip (Screenshot 4). A new video clip is captured in Capture Screen using Mobile Media API and it is recorded according to 3GPP specification using AMR coding for audio and H.263 at 176x144 pixels size at 15 frames per second for video. After a video is captured or loaded (Screenshot 5), the user is presented the Edit Screen (Screenshot 6) that ends the user authentication and video capturing scene.

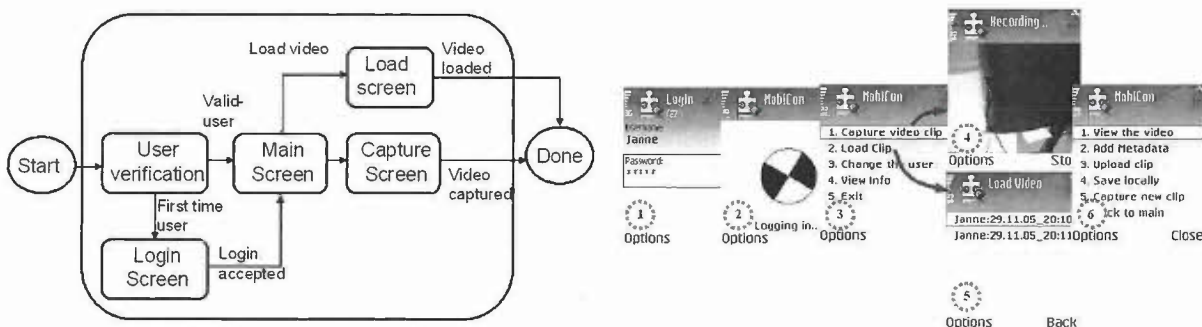

Figure 4: User authentication and video capturing: UI Flow Diagram (left) and UI screenshots (right).

Figure 5 presents the editing and uploading phase starting from the Edit Screen (Screenshot 1), which displays different editing options for the video clip. The user can choose to view the video clip in the Video View Screen (Screenshot 2), enter metadata annotations in the Metadata Screen (Screenshot 3), upload video clip (Screenshots 4, 5 and 6) either through the Access Screen or the DRM Screen, save, and capture a new video clip.

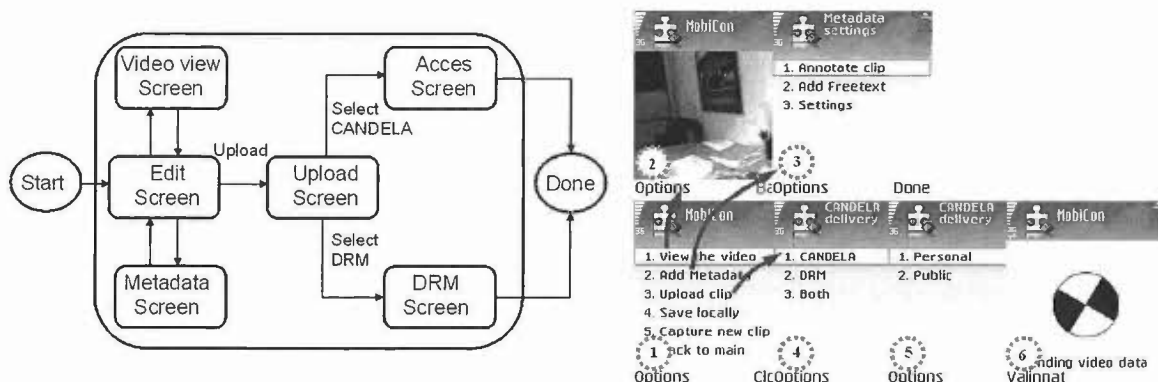

Figure 5: Editing and uploading the captured/loaded video clip: UI Flow Diagram (left) and UI screenshots (right).

In the Edit Screen, the user may choose to upload the clip to the Candela server. The Upload Screen (Screenshot 4) prompts the user to choose the Candela or the DRM delivery channel or both. If the user chooses Candela delivery channel the video clip is uploaded to Candela server over mobile phone network and added to the Candela video database, from where the user can later search and access the video clip. A user must also choose whether the video clip is only for personal use or whether other Candela users can also find the clip via search. This is selected in the Access Screen (Screenshot 5). Then the video clip is uploaded via the Upload Gateway to the user video collection on the Candela server (Screenshot 6). In the server the video clip is handed over to the Video Manager Servlet, which transcodes the video clip into different formats and bit rates in order to provide a scalable service quality for different devices and network connections. Currently, the Video Manager Servlet prepares Real Video, H.264, and H.263 encodings for delivering the captured video content to mobile devices and MPEG-4 file format for desktop computers. In the future, scalable video codecs will remove the need of transcoding [12]. The DRM delivery channel (Screenshot 4), to prepare video clip for DRM protected sharing, is presented in details in Figure 7. The functionalities under the Metadata screen (Screenshot 3) are presented in Figure 6, which illustrates the flow diagram for the metadata annotation phase.

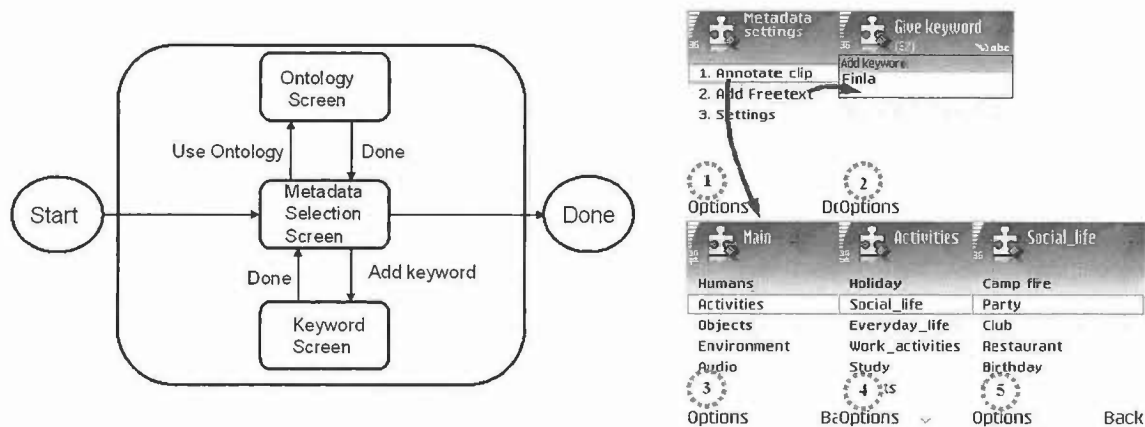

Figure 6: Giving metadata annotations: UI Flow Diagram (left) and UI screenshots (right).

The clip annotation starts from the Metadata Selection Screen (Screenshot 1) where the user has options to annotate clip using terms in a predefined domain ontology stored in the user's personal profile (Screenshots 3-5), add text descriptions by typing the nine-button keypad (Screenshot 2), and edit settings to update personal profile information, which is automatically added to the video clip metadata. When annotating via the Ontology Screen, the domain ontology can be accessed along a three-level hierarchical structure: the main level view (3) contains top-level concepts, which are then expanded in the sub-level menus (4, 5). All three levels are recorded to the clip. MobiCon also gathers context data that is available at the time of capture on the mobile phone such as user name, capture time, and duration of the clip. Additionally, MobiCon is able to connect to a GPS receiver supporting the NMEA protocol via Bluetooth. GPS provides

longitude and latitude coordinates and a timestamp for the metadata. All the video clip metadata is uploaded with the video clip. In the final MPEG-7 file the context data includes the creator's name, region and country, date and time of day, GPS information, and length of the video clip as well as terms given by user and from the ontology tree are embedded in free text annotation elements the MPEG-7 provides.

Figure 7 presents the flow diagram for the DRM protected sharing phase. The starting point is the Delivery Method Screen (Screenshot 1) where the user adds the DRM option. The user is prompted by possible recipients from the mobile phone's contacts list (Screenshot 2). After selecting a receiver, the user can select between two DRM protection methods: Forward-Lock and Combined-Delivery (Screenshot 3). The Forward-Lock method prevents the receiver from resending the shared video clip from their mobile phones and it does not require additional configuration. The Combined-Delivery method (Screenshot 4) is used to specify access rights for the shared video clip. With the Combined-Delivery method, the user can set the dates the receiver can watch the video and how many times the video can be played by the receiver (Screenshot 5). After completing the Rights Selection Screen, the UploadClient sends the video, metadata and DRM information to the UploadGateway, which creates a DRM package at the server side and returns one identification key for each receiver. As soon as Upload Client receives the key(s) it generates and sends SMS messages to the receivers, who can download and play the video clip without MobiCon client software.

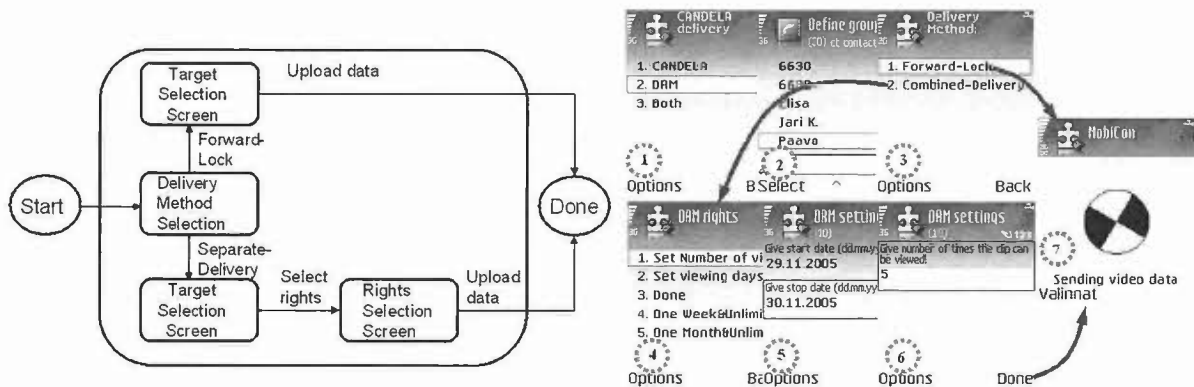

Figure 7: Sharing video DRM protected video clip: UI Flow Diagram (left) and UI screenshots (right).

5. FIELD TRIAL EVALUATION

Before initiating the field trial, MobiCon was tested extensively by a small group of developers/researchers from the Wireless Services group at VTT. Several issues were identified and fixed in the process, and we felt that both the application and the underlying video management service were ready for a field trial with real users. Due to space limitations, we will only summarize the results here; further details about the field trial are given in [13].

The main goal of the MobiCon field trial was to quantify application usability and assess its overall appeal to everyday users. The field trial lasted four weeks, starting on 14 February 2005. We lent each of the ten trial participants a Nokia 6630 MCP with MobiCon preinstalled. The primary author spent some time with each user introducing the application and explaining the main goals of the trial. At the end of the short tutorial, each participant had to take MobiCon for a "test ride" and continue using it for two weeks. Users were instructed to use the application as much as they would "in the real world". In other words, the aim of the trial was neither to stress- nor to beta-test MobiCon, but to replicate typical user behavior in a realistic environment; accordingly, participants were not forced to record, annotate, and upload as many videos as possible. During the trial period, we gathered data about the performance of the application and other context-related data, including user details, time and date; number of user interface (UI) selections made; session duration; type and number of metadata descriptions provided; and captured video duration, size, and upload bit rate. After the end of the trial period, users had to return the MCP and fill out an evaluation questionnaire.

The field trial results showed that MobiCon did overall meet all implementation objectives as specified in Section 3: users were able to capture video clips, annotate them with metadata, upload some of the clips to the video management server, and share clips with others. Both the application logs and the post-trial questionnaires indicated that MobiCon was relatively easy to use, even for inexperienced users. With regard to metadata annotation, most users agreed that an ontology-based term selection is a convenient way to add metadata to a clip, and it is preferred over free-text entries. Nevertheless, many users reported that the ontology tree structure and its size were far from ideal: some complained that

the ontology tree structure was “too large”, and that most terms were of little or no use; others wished the tree included more terms.

Despite the fact that most of the Oulu metropolitan area is covered by a fast 3G/UMTS network, seven out of ten users complained that the network was “slow”. Moreover, the field trial revealed other issues including a couple of bugs which led to application crashes, and the concerns raised by some of the less technologically savvy participants about the security-related questions frequently asked by the MCP operating systems. The latter was due to the fact that MobiCon was not a signed application at the time of the field trial; the former were fixed before the time of this writing.

By and large, the participants were very satisfied with MobiCon (as an MCP application) and are looking forward to using such a service when it becomes commercially available. Even so, the field trial participants suggested several improvements, which, along with our own experiences, guide the evolution to the next phase of development.

6. SYSTEM IMPROVEMENTS AND NEW DIRECTIONS

Given the outcome of the field trial evaluation, we saw the imperative need to ease the annotation process by automation. One approach towards this problem would be to apply content analysis techniques on the video clips. Extracting high-level annotations out of video content is already a challenging task in specialized domains with static and regular content such as sports or news [14, 15]. With home video clips shot with today's camera phones, however, the task is even more daunting: home video content is highly irregular and diverse reflecting the varying interests of people; the technical skills of home videographers are rather limited resulting in shaky and blurry content; the still limited resolutions of phone cameras as well as high compression losses contribute to the bad content quality.

These problems led us to the different and much simpler approach of inferring reasonable annotation suggestions out of the rich context data about the clip capture that is available on mobile phones, as recently also suggested by [16]. For example, suggestions about the time of day, month, and season can be easily derived out of the system time on the phone; information about location of a clip capture can be obtained from the current cell ID or – with more modern phones or a GPS receiver accessible via Bluetooth – even the GPS position; given the location, one may access the user's address book to find out whether the clip was captured at a known location; given the time, one can look up possibly documented events in a calendar; etc.

Following this idea, we created an annotation web service for the creation of context-based annotation suggestions [6] and integrated it into the Candela system as outlined by Figure 8. With the creation of this web service, we pursued several goals:

Firstly, an annotation web service was painless to integrate with the already existing MobiCon application. After video capture, MobiCon merely needs to create an HTTP request with the context data and add the returned suggestions to the list of annotation keywords.

The second goal is extensibility. As it is easy to come up with further ideas of how to generate reasonable suggestions out of context, we want to be able to flexibly integrate new annotation methods as they become available. Therefore, we implemented the annotation web service on top of a plug-n-play bus architecture, which facilitates rapid integration of new methods for the generation of annotation suggestions. In addition, a centralized web service eliminates the logistic problem of deploying new annotation methods on the mobile clients.

Thirdly, the generation of annotation suggestions on a server relieved us from concerns with regard to the computational complexity of the generation of annotation suggestions. The highly parallelized architecture of the annotation bus further contributes to that aspect: all annotation suggestions are generated in parallel threads minimizing response times for each request and maximizing server utilization.

Figure 8 illustrates overview to the bus architecture of the annotation web service with the different modules currently implemented for the generation of annotation suggestions based on initial annotation.

In addition to adding the context-aware annotation web service, we also improved manual annotation of video clips. Because of the user complaints in the field trial with regard to the suitability of the predefined domain ontology for annotation to their personal situation and interests, we re-designed the system such that every user – excluding some general concepts forming the upper level of the hierarchy – can modify the ontology concepts and structure. Users can thus optimize their ontologies to their individual annotation needs, such that they can reach the concepts important to them in few navigation steps and without having to scroll through many irrelevant concepts on a small phone display on the way.

The individual ontologies of users are managed by an ontology manager on the Candela server. When a user logs in to MobiCon, the application receives the personal ontology of the user from the ontology manager in RDF format and caches it for successive use along with the user's other profile data in the phone memory.

We also have made other minor improvements to annotations. Now, MobiCon memorizes that last five keyword entries of the user and offers them for fast selection.

We believe that all these improvements will enhance the Mobicon user experience, making it easier, for the user, to annotate the videos with metadata. But we also see it is necessary to verify these improvements with a new field trial in a near future.

We have also further improvement ideas to the annotation process, which we are planning to integrate to MobiCon; for example, an even better metadata collection method suiting the nature of phone device could be audio annotation, so the user could add metadata descriptions to the videos just by speaking. Also typing metadata annotations, with nine-button keypad, could be made easier by using dictionary assisted predictions for typed words.

With regard to the sharing of clips, MobiCon's current functionality is still limited, allowing the sharing of clips only right after capture. We are currently investigating the integration of a user interface into MobiCon that allows users to share any clip existing in their collections. In addition, the possibility of using other network connections, besides mobile networks, will be studied. Moreover, the remarks about slow cellular upload links, especially over GPRS, and the potential of high transfer fees in a public 3G network, prompted us to consider adding a peer-to-peer delivery channel as well. For example, users could connect to fixed networks by using network technologies like Bluetooth and WLAN, which can already be found on new mobile devices or they could use Bluetooth to share videos with user nearby. This is expected to satisfy a number of users who would prefer to capture several videos, annotate them on the spot, but upload them later.

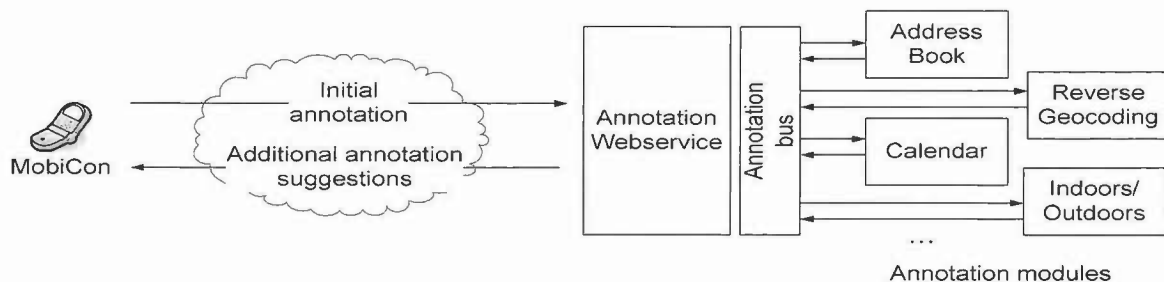

Figure 8: The Candela Annotation Web Service

7. RELATED WORK

Most of the existing mobile phone-based content management systems provide only capturing, annotating, and sharing of still photos, for example [4, 17]. Similar commercial applications as MobiCon exists such as Kodak Mobile (kodakmobile.com), Nokia's Movie Director (nokia.com), Nokia Album (nokia.com), and Nokia Lifeblog (nokia.com/lifeblog) and PhotoBlog (<http://www.futurice.fi/PhotoBlog.html>), but there is currently no similar mobile application that combines all video management features, i.e., video capturing, annotation using different context sources, sharing and storing videos for searching, into one [6, 13]. In general, existing commercial content sharing applications use different sharing methods such as MMS, email, blogs and even PC based tools for home personal video management [18].

Mobile video authoring applications exist for mobile phones without video sharing and DRM support, but they provide more advanced video editing tools in mobile device. For example, mProducer [19] provides video recording and editing in a mobile device, but it focuses on maximizing content capture space in a device and assisting the user in video editing, for example, by supporting shot detection and removing blurred frames. Video blogging using mobile devices is also becoming popular. FrameDrops [20] allows commenting captured video clips and provides video sharing via interactive web pages that align video clips over a map based on capture position. FrameDrops is targeted for work groups and online communities and they use Flash video format. MobiCon and Candela system targets personal video management by supporting video search in both mobile and desktop environments allowing sharing in different video formats.

Recent video annotation research is more focused on automatically summarizing video data from existing MPEG-7 video descriptions [21, 22] and enhancing the results using a query-based video personalization and summarization to show a shortened video summary of a large video content [23]. Also, some applications exist that automatically gather

video metadata from a specific type of video content, for example news broadcasts. IBM [23] has also developed system for creating personalized video content from video databases for PDA and PC users. We used similar technologies for example, MPEG-7 metadata files, but the main differences to MobiCon and video server are that we support DRM to control video redistribution, we only use high-level features (objects, person names, situation, address and town names) to annotate the video clips in MPEG-7 file and we need to transcode video clips for streaming both PC and mobile devices. We also did not implement shot boundary detection in MobiCon because mobile videos are short and they typically consist of a single shot. More about mobile video streaming can be found in [21].

A mobile network-based video sharing service is already commercially launching by mobile operators such as Telecom Italia Mobile and TLC in Hong Kong. In telecommunication networks, a video sharing service is based on IMS and it allows sharing real-time or pre-recorded video clips during normal voice calls using a separate data call. Both parties hear each other and watch the same video until they end the video sharing call [3]. MobiCon type of tools will benefit of IMS system, since IMS allows point-to-point access between mobile phones and it can replace SMS-based content delivery. MobiCon only uses a GPRS packet connection to transmit video data to video server and users are not point-to-point connected and sharing is not real-time. We expect that similar applications as MobiCon will be available also as IMS services managed by mobile operators.

Finally, other technologies such as sensors in mobile phone [19] and RFID tags and readers [24] will be available to provide alternative ways to users to access shared content.

8. CONCLUDING REMARKS

This paper introduced a video management solution, which has at its core MobiCon, a mobile camera phone application. We illustrated a typical scenario involving a tourist creating short videos while on a sightseeing tour, laid out our original implementation objectives, described the overall system architecture, and detailed the main features of the application using Interface Flow Diagrams and application screenshots. After summarizing the results of the first MobiCon field trial, we presented a set of improvements to the original implementation of the application, and gave a short account of our latest development efforts. Finally, this paper compared MobiCon with other related research and development efforts and pointed out significant differences, stating possible future directions.

Although MobiCon has reached a certain level of maturity, there are many issues that still remain to be tackled. Certain security concerns regarding video clip access for invited receivers, along with improvements on the digital rights management component, top the list. Once these have been addressed, the next step should be to open up the video management server to a larger group of users and allow them to use it in combination with MobiCon. This will permit us to evaluate the complete service under a much larger and diverse set of configurations, which ideally should include users in other countries and, hopefully, in other continents as well. Porting MobiCon to more platforms is also in our current plans, as is pursuing business development opportunities for we seek closer cooperation with mobile network operators and startup video management service providers in order to create a commercially-available turnkey solution. To that end, we are exploring alternative user scenarios, which are not restricted to the home video market segment. Finally, depending on user interest, we are considering adding support for short-range, peer-to-peer communication using Bluetooth and WiFi.

On the research front, we are exploring how content analysis methods can be integrated with the annotation web service. Although the system architecture has been designed to be extensible from the ground up, it is still not meaningful to implement annotation suggestion modules based on content analysis methods, because the video would have first to be uploaded and analyzed by the server in order for the annotation web service to provide suggestions. The resulting delay in the annotation process may be prohibitive. Perhaps the solution can come from a distributed version of the annotation bus, which allows us to keep annotation suggestion modules on the MCP. This will also address some privacy concerns arising from the need to have certain personal context data, such as address book contacts and calendar entries, transferred over the cellular network to the web service.

ACKNOWLEDGEMENTS

MobiCon and Candela were developed as part of the EUREKA/ITEA CANDELA (Content Analysis, Networked Delivery and Architectures) project during 2004-2005. Funding provided by TEKES National Technology Agency of Finland, and VTT Technical Research Centre of Finland is gratefully acknowledged.

REFERENCES

1. L. Novak and M. Svensson, "MMS - Building on the success of SMS", *Ericsson Review*, **78**(3), pp. 102–109, 2001.
2. J.F. Huber, "Toward the mobile Internet", *Computer*, **35**(10), pp. 100–102, 2002.
3. Nokia, "White Paper: Video Sharing v1.0", Forum Nokia, 2005.
4. R. Sarvas, E. Herrarte, A. Wilhelm, and M. Davis, "Metadata creation system for mobile images", *Proceedings of International Conference on Mobile Systems, Applications, and Services (ACM MobiSys)*, pp. 36–48, ACM Press, Boston, Massachusetts, USA, 2004.
5. A. Sachinopoulou, S.-M. Mäkelä, S. Järvinen, P. Pietarila, J. Peltola, and M. Jurvansuu, "Personal Video Retrieval and Browsing for Mobile Users", *Multimedia on Mobile Devices, Proceedings of SPIE-IS&T Electronic Imaging*, **5684**, pp. 219–230, 2005.
6. J. Lahti, U. Westermann, M. Palola, J. Peltola, and E. Vildjiounaite, "Context-Aware Mobile Capture and Sharing of Video Clips", *Handbook of Research on Mobile Multimedia*, I. K. Ibrahim & J. Kepler (eds.), Idea Group, Hershey, Pennsylvania, USA, 2006, to appear.
7. B. S. Manjunath, P. Salembier, and T. Sikora (Eds.), *Introduction to MPEG-7: Multimedia Content Description Language*, John Wiley & Sons, New York, New York, USA, 2002.
8. J. Vehkaperä and J. Peltola, "Optimized Decoding Scheme for Erroneous MPEG-4 FGS Bitstream", *Proc. of IEEE International Symposium on Circuits and Systems 2005 (ISCAS2005)*, Kobe, Japan, 2005.
9. W. Jonker and J.-P. Linnartz, "Digital Rights Management in Consumer Electronics Products", *IEEE Signal Processing Magazine*, **21**(2), pp. 82–91, 2004.
10. J. Irwin, "Digital Rights Management: The Open Mobile Alliance DRM specifications", *Information Security Technical Report*, **9**(4), pp. 22–31, 2004.
11. S. Ambler, *The Object Prime 3rd Edition, Agile Model Driven Development with UML 2*, Cambridge University Press, 2004.
12. A. Vetro, C. Christopoulos, and H. Sun, "Video transcoding architectures and techniques: An overview", *IEEE Signal Processing Magazine*, **20**(2), pp. 18–29, 2003.
13. J. Lahti, K. Pentikousis, and M. Palola, "MobiCon: Mobile video recording with integrated annotations and DRM", *Proceedings of IEEE Consumer Communications and Networking Conference (IEEE CCNC 2006)*, Las Vegas, Nevada, USA, 2006, to appear.
14. P. Duygulu, J. Pan, and D.A. Forsyth, "Towards Auto-Documentary: Tracking the Evolution of News Stories", *Proceedings of ACM Multimedia*, pp. 820–827, New York, New York, USA, 2004.
15. H. Xu and T. -S. Chua, "The Fusion of Audio-Visual Features and External Knowledge for Event Detection in Team Sports Video", *Proceedings of the 6th ACM SIGMM International Workshop on Multimedia Information Retrieval (MIR)*, pp. 127–134, New York, New York, USA, 2004.
16. M. Davis, S. King, N. Good, and R. Sarvas, "From Context to Content: Leveraging Context to Infer Multimedia Metadata", *Proceedings of ACM Multimedia*, pp. 188–195, New York, New York, USA, 2004.
17. M. Davis, "Mobile Media Metadata: Metadata Creation System for Mobile Images", *Proceedings of ACM Multimedia*, pp. 425–445, New York, New York, USA, 2004.
18. Y. Wang, P. Zhao, D. Zhang, M. Li, and H. Zhang, "MyVideos – A System for Home Video Management", *Proceedings of ACM Multimedia*, pp. 412–413, Juan Les Pins, France, 2002.
19. C.-M. Teng, C.-I. Wu, Y.-C. Chen, H. Chu, and J. Y. Hsu, "Design and Evaluation of mProducer: A mobile authoring tool for personal experience computing", *Proceedings of the third International Conference on Mobile and Ubiquitous Multimedia (MUM)*, pp. 141–148, College Park, Maryland, USA, 2004.
20. T. Gross and M. Kleppe, "FrameDrops: a mobile VideoBlog for workgroups and virtual communities", *Proceedings of International Conference on Supporting Group Work*, pp. 128–131, Sanibel Island, Florida, USA, 2005.
21. M. Etoh and S. Sekiguchi, "MPEG-7 enabled digest video streaming over 3G mobile network", *Proceedings of the 12th International PacketVideo Workshop*, Pittsburgh, Pennsylvania, USA, 2002.
22. P. M. Fonseca and F. Pereira, "Automatic video summarization based on MPEG-7", *Signal Processing: Image Communication*, **19**(8), pp. 685–699, 2004.
23. B. L. Tseng, C.-Y. Lin, and J. R. Smith, "Video personalization and summarization system for usage environment", *Journal of Visual Communication and Image Representation*, **15**(3), pp. 370–392, 2004.
24. Y.-M. Cheng, W. Yu, and T.-C. Chou, "Capturing context: Life is sharable: blogging life experience with RFID embedded mobile phones", *Proceedings of the 7th International Conference on Human Computer Interaction with Mobile Devices and Services (MobileHCI)*, pp. 295–298, Salzburg, Austria, 2005.

Technical Program

IS&T/SPIE 18th Annual Symposium

Electronic Imaging

Science and Technology

15-19 January 2006 San Jose Marriott and San Jose Convention Center • San Jose, California USA

Sponsored by:

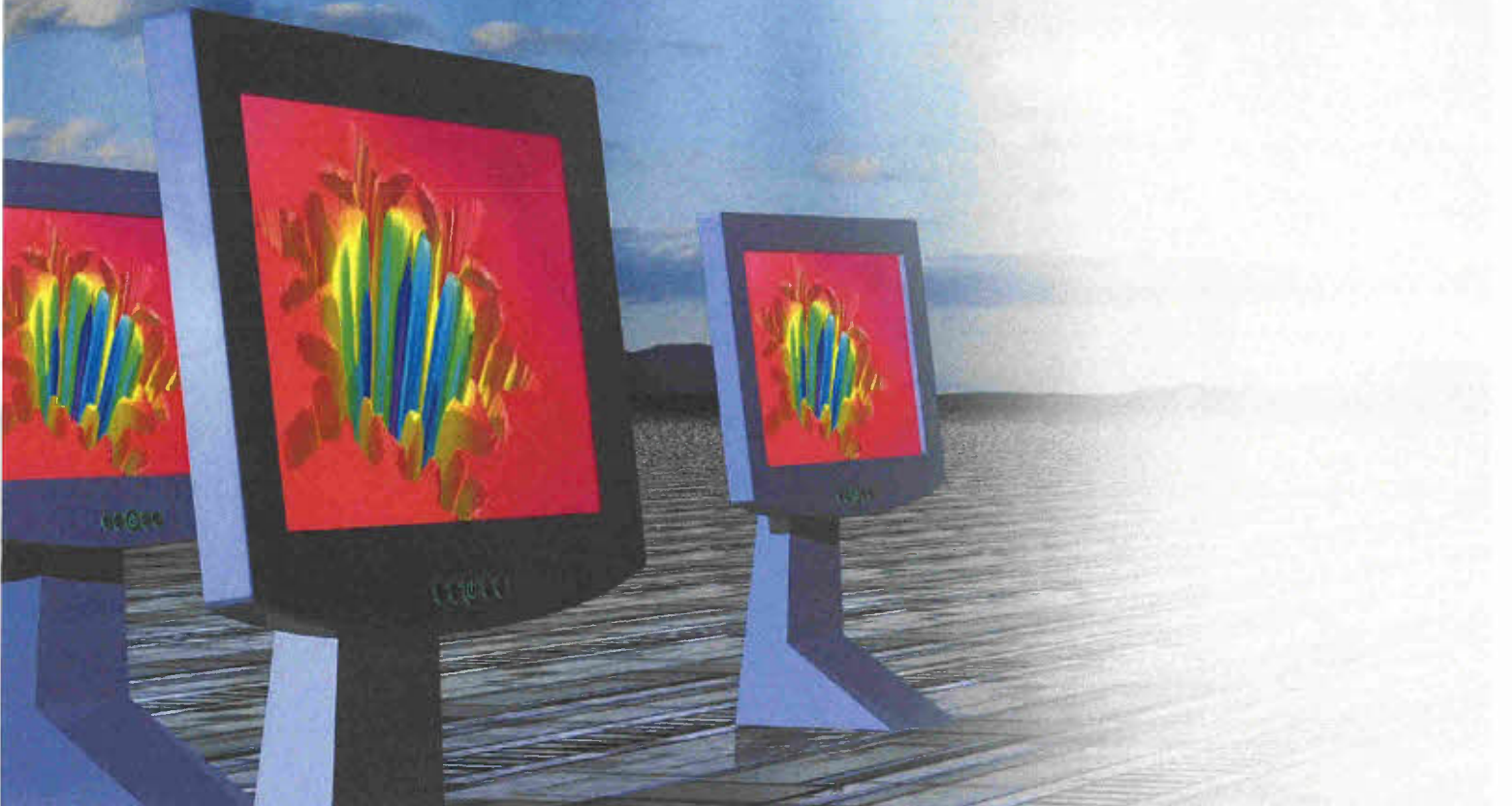
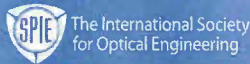

Technical Program

IS&T/SPIE 18th Annual Symposium

Electronic Imaging

Science and Technology

15–19 January 2006 San Jose Marriott and San Jose Convention Center • San Jose, California USA

Conferences • Continuing Education • Technical Exhibition • Demonstrations

Welcome

We are all too busy. If your jobs are like ours, then you are expected to produce more innovation, more products, more research, more students, more money, but all with less time. So how does participating in EI 2006 fit into this picture?

Well, here is the straight answer as to why the Electronic Imaging Symposium is a great investment of your time and resources.

- **Defines the cutting edge in imaging research** - The EI symposium, and its associated publication the *Journal of Electronic Imaging*, have been defining the envelope of high impact digital imaging research since their inception. Because of its leading role, EI is where the innovation leaders in imaging research go to find out about the newest imaging systems, methods, instrumentation, and algorithms.
- **Provides broad coverage with tremendous technical depth** - The unique structure of EI leads to a rich marketplace of ideas where a broad range of topics are discussed in great technical depth. Each year, the EI symposium starts new conferences on important new topics and reinvigorates highly respected existing conferences through the incorporation of new research and participants.
- **Promotes an atmosphere for professional networking** - Because of its organization into primarily single-tracked conferences, the symposium has a very personal and friendly atmosphere that gives technical experts and researchers an opportunity to learn what they need and also, to efficiently network on a professional level.
- **Enhances your professional value** - EI gives you great opportunities to publish high-quality research, meet widely recognized experts in your field, and keep up on "hot" technical trends. All these things enhance the value of both you and your organization.
- **Provides opportunities for professional participation** - Each year new people get involved and infuse EI with fresh new ideas. There are numerous opportunities to participate, and we want both your input and your participation! If you have ideas, feel free to speak to your conference chair, or other EI representatives about getting involved.
- **Leverages the Silicon Valley community** - Every year EI is held in San Jose, the heart of Silicon Valley and the hub of the international information technology industry. Each year we look forward to visiting the institutions that are shaping the future of the imaging industry, and we also don't mind the warm weather!

We look forward to seeing you both this year and for years to come.

IS&T/SPIE would like to express their deepest appreciation to the symposium chairs, conference chairs, and program committees who have so generously given of their time and advice to make this symposium possible. The symposium, like our other conferences and activities, would not be possible without the dedicated contribution of our participants and members.

2006 Symposium Chairs



Charles A. Bouman,
Purdue Univ.



Gabriel G. Marcu,
Apple Computer, Inc.

Contents

Special Events 6

Plenaries 7

Conferences:

Conference Index 3

Daily Overview 4

Technical Conferences . 10-67

Course Daily Overview 5

General Information 8-9

Technical Abstract

Summaries 68-267

Participants 268-278

Publication Order form 279

Proceedings 280

Electronic Imaging

Symposium Chairs

Charles A. Bouman, Purdue Univ.
Gabriel G. Marcu, Apple Computer, Inc.

Symposium Organizing Committee

Thrasylvoulos N. Pappas, Northwestern Univ.
Andrew J. Woods, Ctr. for Marine Science and Technology/Curtin Univ. of Technology (Australia)

Short Course Chairs

Edward J. Delp III, Purdue Univ.
Michael A. Kriss, Consultant

Exhibition Chair

A. Ufuk Agar, Garanti Technologies (Turkey)

Demonstration Chair

Neil A. Dodgson, Univ. of Cambridge (United Kingdom)

Technical Organizing Committee

Jan P. Allebach, Purdue Univ.
John G. Apostolopoulos, Hewlett-Packard Labs.
Jaakko T. Astola, Tampereen Teknillinen Yliopisto (Finland)
Morley M. Blouke, Ball Aerospace & Technologies Corp.
Mark T. Bolas, Univ. of Southern California
Katy Börner, Indiana Univ.
Charles A. Bouman, Purdue Univ.
Surendar Chandra, Univ. of Notre Dame
Edward Y. Chang, Univ. of California/Santa Barbara
Hui Chao, Hewlett-Packard Co.
Chang Wen Chen, Florida Institute of Technology
Brian D. Corner, U.S. Army Natick Soldier Ctr.
Reiner Creutzburg, Fachhochschule Brandenburg (Germany)
Luke C. Cui, Lexmark International, Inc.
Scott J. Daly, Sharp Labs. of America, Inc.
Edward J. Delp III, Purdue Univ.
Jeffrey M. DiCarlo, Hewlett-Packard Labs.
Neil A. Dodgson, Univ. of Cambridge (United Kingdom)
Edward R. Dougherty, Texas A&M Univ.
Karen O. Egiazarian, Tampereen Teknillinen Yliopisto (Finland)
Robert F. Erbacher, Utah State Univ.
Reiner Eschbach, Xerox Corp.
Theo Gevers, Univ. van Amsterdam (Netherlands)
Carsten Griwodz, Univ. of Oslo (Norway)
Matti T. Gröhn, CSC-Scientific Computing Ltd. (Finland)
Alan Hanjalic, Technische Univ. Delft (Netherlands)
Francisco Hideki Imai, Rochester Institute of Technology
Nasser Kehtarnavaz, The Univ. of Texas at Dallas
Phillip A. Laplante, The Pennsylvania State Univ.
Longin Jan Latecki, Temple Univ.
Peng Li, GEO-Centers, Inc.

Xiaofan Lin, Hewlett-Packard Labs.
Gabriel G. Marcu, Apple Computer, Inc.
Russel A. Martin, Foveon USA
Ian E. McDowall, Fakespace Labs., Inc.
Fabrice Meriaudeau, Univ. de Bourgogne (France)
John O. Merritt, The Merritt Group
Eric L. Miller, Northeastern Univ.
Yoichi Miyake, Chiba Univ. (Japan)
David M. Mount, Univ. of Maryland/College Park
Nasser M. Nasrabadi, Army Research Lab.
Kurt Niel, Fachhochschule Wels (Austria)
Thrasylvoulos N. Pappas, Northwestern Univ.
Syed A. Rizvi, CUNY/College of Staten Island
Jonathan C. Roberts, Univ. of Kent (United Kingdom)
Bernice E. Rogowitz, IBM Thomas J. Watson Research Ctr.
Mitchell Rosen, Rochester Institute of Technology
Amir Said, Hewlett-Packard Labs.
Nitin Sampat, Rochester Institute of Technology
Simone Santini, Univ. of California/San Diego
Raimondo Schettini, DISCo/Univ. degli Studi di Milano-Bicocca (Italy)
Nicu Sebe, Univ. van Amsterdam (Netherlands)
Kazem Taghva, Univ. of Nevada/Las Vegas
Jarmo H. Takala, Tampereen Teknillinen Yliopisto (Finland)
Matthew Tocheri, Arizona State Univ.
Shoji Tominaga, Osaka Electro-Communication Univ. (Japan)
Rudolf L. van Renesse, VanRenesse Consulting (Netherlands)
Ping Wah Wong, IDzap LLC
Andrew J. Woods, Ctr. for Marine Science and Technology/Curtin Univ. of Technology (Australia)
Angela Y. Wu, American Univ.

Program on

3D Imaging, Interaction, and Measurement

Mon-Weds 6055A **Stereoscopic Displays and Applications XVII**
(*Woods, Dodgson, Merritt*) p. 10

Thurs 6055B **The Engineering Reality of Virtual Reality 2006**
(*Bolas, McDowall*) p. 14

Mon-Tues 6056 **Three-Dimensional Image Capture and Applications VI**
(*Corner, Li, Tocheri*) p. 15

Program on

Imaging, Visualization, and Perception

Mon-Wed 6057 **Human Vision and Electronic Imaging XI**
(*Rogowitz, Pappas, Daly*) p. 17

Tues-Thurs 6058 **Color Imaging XI: Processing, Hardcopy, and Applications**
(*Eschbach, Marcu*) p. 20

Tues-Thurs 6059 **Image Quality and System Performance III**
(*Cui, Miyake*) p. 22

Mon-Tues 6060 **Visualization and Data Analysis 2006**
(*Erbacher, Roberts, Gröhn, Börner*) p. 24

Tues-Thurs 6061 **Internet Imaging VII**
(*Gevers, Santini, Schettini*) p. 26

Mon-Tues 6062 **Spectral Imaging: Eighth International Symposium on Multispectral Color Science**
(*Rosen, Imai, Tominaga*) p. 28

Program on

Image Processing

Mon-Tues 6063 **Real-Time Image Processing III**
(*Kehtarnavaz, Laplante*) p. 30

Mon-Tues 6064A **Image Processing: Algorithms and Systems V**
(*Dougherty, Astola, Egiazarian*) p. 32

Tues-Weds 6064B **Applications of Neural Networks and Machine Learning in Image Processing X**
(*Nasrabadi, Rizvi*) p. 34

Mon-Weds 6065 **Computational Imaging IV**
(*Bouman, Miller, Pollak*) p. 36

Tues-Weds 6066 **Vision Geometry XIV**
(*Latecki, Mount, Wu*) p. 39

Weds-Thurs 6067 **Document Recognition and Retrieval XIII**
(*Taghva, Lin*) p. 41

Program on

Digital Imaging Sensors and Applications

Tues-Thurs 6068 **Sensors, Cameras, and Systems for Scientific/Industrial Applications VIII**
(*Blouke*) p. 43

Mon-Tues 6069 **Digital Photography II**
(*Sampat, DiCarlo, Martin*) p. 45

Mon-Tues 6070 **Machine Vision Applications in Industrial Inspection XIV**
(*Meriaudeau, Niel*) p. 47

Program on

Multimedia Processing and Applications

Weds-Thurs 6071 **Multimedia Computing and Networking 2006**
(*Chandra, Griwodz*) p. 49

Mon-Thurs 6072 **Security, Steganography, and Watermarking of Multimedia Contents VIII**
(*Delp, Wong*) p. 51

Tues-Thurs 6073 **Multimedia Content Analysis, Management, and Retrieval 2006**
(*Chang, Hanjalic, Sebe*) p. 55

Mon-Tues 6074 **Multimedia on Mobile Devices II**
(*Creutzburg, Takala, Chen*) p. 58

Mon-Tues 6076 **Digital Publishing**
(*Allebach, Chao*) p. 62

Program on

Optical Security and Anti-Counterfeiting

Tues-Thurs 6075 **Optical Security and Counterfeit Deterrence Techniques VI**
(*van Renesse*) p. 60

Program on

Visual Communications and Image Processing

Tues-Thurs 6077 **Visual Communications and Image Processing 2006**
(*Apostolopoulos, Said*) p. 64

Conference Daily Overview

Monday Tuesday Wednesday Thursday

Program on

3D Imaging, Interaction, and Measurement

Conf. 6055A **Stereoscopic Displays and Applications XVII** (Woods, Dodgson, Merritt), p. 10

Conf. 6056 **Three-Dimensional Image Capture and Applications VI** (Corner, Li, Tocheri), p. 15

Conf. 6055B **The Engineering Reality of Virtual Reality 2006** (Bolas, McDowall), p. 14

Program on

Imaging, Visualization, and Perception

Conf. 6057 **Human Vision and Electronic Imaging XI** (Rogowitz, Pappas, Daly), p. 17

Conf. 6058 **Color Imaging XI: Processing, Hardcopy, and Applications** (Eschbach, Marcu), p. 20

Conf. 6059 **Image Quality and System Performance III** (Cui, Miyake), p. 22

Conf. 6061 **Internet Imaging VII** (Gevers, Santini, Schettini), p. 26

Conf. 6060 **Visualization and Data Analysis 2006** (Erbacher, Roberts, Gröhn, Börner), p. 24

Conf. 6062 **Spectral Imaging: Eighth International Symposium on Multispectral Color Science** (Rosen, Imai, Tominaga), p. 28

Program on

Image Processing

Conf. 6063 **Real-Time Image Processing III** (Kehtarnavaz, Laplante), p. 30

Conf. 6064A **Image Processing: Algorithms and Systems V** (Dougherty, Astola, Egiazarian), p. 32

Conf. 6064B **Applications of Neural Networks and Machine Learning in Image Processing X** (Nasrabadi, Rizvi), p. 34

Conf. 6065 **Computational Imaging IV** (Bouman, Miller, Pollak), p. 36

Conf. 6066 **Vision Geometry XIV** (Latecki, Mount, Wu), p. 39

Conf. 6067 **Document Recognition and Retrieval XIII** (Taghva, Lin), p. 41

Program on

Digital Imaging, Sensors, and Applications

Conf. 6068 **Sensors, Cameras, and Systems for Scientific/Industrial Applications VIII** (Blouke), p. 43

Conf. 6069 **Digital Photography II** (Sampat, DiCarlo, Martin), p. 45

Conf. 6070 **Machine Vision Applications in Industrial Inspection XIV** (Meriaudeau, Niel), p. 47

Program on

Multimedia Processing and Applications

Conf. 6071 **Multimedia Computing and Networking 2006** (Chandra, Griwodz), p.49

Conf. 6072 **Security, Steganography, and Watermarking of Multimedia Contents VIII** (Delp, Wong), p. 51

Conf. 6073 **Multimedia Content Analysis, Management, and Retrieval 2006** (Chang, Hanjalic, Sebe), p. 55

Conf. 6074 **Multimedia on Mobile Devices II** (Creutzburg, Takala, Chen), p. 58

Conf. 6076 **Digital Publishing** (Allebach, Chao), p. 62

Program on

Optical Security and Anti-Counterfeiting

Conf. 6075 **Optical Security and Counterfeit Deterrence Techniques VI** (van Renesse), p. 60

Program on

Visual Communications and Image Processing

Conf. 6077 **Visual Communications and Image Processing 2006** (Apostolopoulos, Said), p. 64

Sunday	Monday	Tuesday	Wednesday	Thursday
--------	--------	---------	-----------	----------

Digital Imaging

SC753 **Image Quality Evaluation for Digital Cameras Based on Existing ISO Standards** (Wueller, Matherson) 8:30 am to 5:30 pm

SC504 **Introduction to CCD and CMOS Imaging Sensors and Applications** (Janesick) 8:30 am to 5:30 pm

SC760 **CCD Technology/ Digital Photographic Systems Technology** (Theuwissen) 8:30 am to 5:30 pm

SC762 **Device Simulation for Image Quality Evaluation** (Farrell) 8:30 am to 5:30 pm

SC772 **High Dynamic Range Techniques: From Acquisition to Display** (Heidrich, Hoefflinger, Myszkowski) 8:30 am to 5:30 pm

SC513 **Practical MTF and Noise Performance Measurement for Digital Cameras and Scanners** (Burns, Williams) 8:30 am to 5:30 pm

Students: Save 50% on course registrations!

Register for Courses at the registration desk.

Electronic Imaging Technology

SC066 **Fundamentals of Electronic Image Processing** (Weeks) 8:30 am to 5:30 pm, \$450 / \$53

SC589 **Video Compression: Standards and Trends** (Rabbani) 8:30 am to 5:30 pm

SC590 **Advanced Digital Image and Video Enhancement Algorithms** (Rabbani) 8:30 am to 5:30 pm

SC763 **Subband/Wavelet Scalable Video Coding** (Woods) 8:30 am to 12:30 pm, \$220 / \$260

SC761 **Novel Spatially Adaptive Anisotropic Local Approximation Techniques in Image Processing** (Katkovnik, Egiazarian, Astola) 8:30 am to 12:30 pm

SC685 **Content-based Image and Video Retrieval** (Gevers, Sebe) 1:30 to 5:30 pm

SC491 **Neural Networks Applications in Image Processing** (Nasrabadi) 8:30 am to 5:30 pm

Electronic Imaging Applications

SC084 **An Introduction to Cryptography and Digital Watermarking with Applications to Multimedia Systems and Forensics** (Delp, Dittmann) 8:30 am to 5:30 pm

SC060 **Stereoscopic Display Application Issues** (Merritt, Woods) 8:30 am to 5:30 pm

SC766 **Video Surveillance** (Ebrahimi, Dufaux) 8:30 am to 5:30 pm

SC764 **Filter Banks and Wavelets: Design and Use in Perceptual Coding** (Schuller) 1:30 to 5:30 pm

SC767 **Practical Implementations of Machine Vision Systems within Technical Processes** (Niel) 8:30 am to 12:30 pm

Biometrics and Security

SC686 **Biometrics: Applications, Technologies, Standards and Evaluation** (Vielhauer) 8:30 am to 5:30 pm

SC759 **Ownership of the Electronic Image: Overview of Copyright, Privacy, and Liability Issues** (Williams) 1:30 to 5:30 pm

SC087 **Optical Document Security** (van Renesse) 8:30 am to 12:30 pm

Color and Perception

SC754 **Human Shape Perception** (Pizlo, Latecki) 8:30 am to 5:30 pm

SC765 **The Biology, Physics, and Metrology of Color Perception** (Appell) 8:30 am to 5:30 pm

SC516 **Color Considerations for Liquid Crystal Displays** (Marcu) 8:30 am to 12:30 pm

SC075 **Effective Color Computing** (Marcu) 1:30 to 5:30 pm

Special Events

Technical Group Meeting

Members and nonmembers alike are invited to attend this informative meeting that provides excellent networking opportunities.

Electronic Imaging

Marriott Ballroom 3

Monday 16 January 7:30 to 9:30 pm

Chair: **Gabriel Marcu**, Apple Computer, Inc.

This group addresses diverse research, engineering, and specialized applications of electronic imaging devices or systems. Because of the diverse topical areas within electronic imaging, the technical group covers image processing, image capture, display and hardcopy, system integration and visualization. Application areas are just as far-reaching. They include industrial automation, graphic arts, aerospace sensing, remote sensing, document processing, high-resolution television, medical imaging, and all areas of digital image processing, including analysis, compression and restoration. The group members are strongly encouraged to propose topics of interest for the next meeting and to submit short articles for publications in the Electronic Imaging Newsletter which serves to promote the topics of interest to the Group.

About the IS&T/SPIE Electronic Imaging Technical Group

Joint sponsorship by the IS&T and SPIE provides even more benefits and contacts for members of the technical group through the close partnership of the two societies. Both IS&T and SPIE members may join the technical group at the member rate of just \$15 per year.

Technical group benefits include:

- a twice-yearly newsletter covering events in the field
- an annual directory of members
- discounts on selected publications, including the SPIE/IS&T copublished quarterly *Journal of Electronic Imaging*.

Poster Session

San Jose Convention Center, Exhibit Hall 1

Tuesday, 17 January 5:30 to 7:00 pm

Conference attendees are invited to the poster session. Authors of poster papers will be on hand during this session to answer questions and provide in-depth discussion concerning their papers. Attendees are requested to wear their conference registration badges to the poster session.

Authors can set up posters after 10:00 am on Tuesday. Poster supplies (pushpins) will be available. Other supplies can be obtained from the Speakers' Audio Visual Desk.

Posters can be previewed during the day of the event before the formal poster session begins at 5:30 pm.

Authors must remove their papers at the conclusion of the poster reception. It is the author's responsibility to remove their posters immediately after the session. Papers not removed will be considered unwanted and will be discarded. The Societies assume no responsibility for posters left up after the end of the poster reception.

All-Conference Reception

Marriott Ballroom 4-6

Wednesday 18 January 7:30 pm to 9:30 pm

Plan to join us for this great opportunity to get to know your Electronic Imaging colleagues. All attendees are invited to relax and enjoy a pleasant evening with friends old and new!

Symposium Demonstration Session

San Jose Convention Center, Exhibit Hall 1

Tuesday 17 January 5:30 to 8:30 pm

Conference Chair: **Neil A. Dodgson**, Univ. of Cambridge (United Kingdom)

The highly-successful, interactive, hands-on demonstration of stereoscopic hardware, software, and display—traditionally a component of the Stereoscopic Display and Applications Conference—will be expanded this year to include research demonstrations and products related to the entire Electronic Imaging Symposium.

3D Phantogram Exhibit

San Jose Convention Center, Concourse 1 Lobby

Tuesday 17 January 10:00 am to 8:30 pm

Wednesday 18 January 10:00 am to 4:00 pm

Phantograms are a relatively new "3D art form" which place realistic three-dimensional images within hand's reach of the observer. In some ways like a hologram, but in other ways not, phantograms use conventional stereoscopic display technology in a special way to present images that are enchanting. Be prepared to experience a new reality with this innovative combination of art and technology.

Exhibition and Bookfair Hours

Tuesday 17 January 10:00 am to 5:00 pm

Select exhibitors may choose to stay open to 8:30 pm during the Demonstration and Poster Sessions

Wednesday 18 January 10:00 am to 4:00 pm

2006 Exhibitors

Ukrainian Chapter of SPIE—The International Society for Optical Engineering

3D Consortium

Photron USA

Institute for Microelectronics Stuttgart

ABBYY USA Software House

Photonics Spectra

Vision Systems Design

Wiley

Morgan Kaufman/Elsevier

Vision Gates 360°

Plenaries

Marriott Ballroom 1-6

Tuesday 17 January 8:30 to 9:15 am

Image Processing: Interconnections



Thomas S. Huang, Beckman Institute for Advanced Science and Technology, Univ. of Illinois at Urbana-Champaign, Recipient of the 2006 Electronic Imaging Scientist of the Year Award

We live in a complex world. To solve complex problems, we need to combine knowledge and technologies from diverse fields. Image processing often plays a key role in these interdisciplinary problems. In a narrow sense, image processing

comprises three areas: coding, enhancement/restoration/reconstruction, and analysis (mensuration/detection/recognition). These three areas are, of course, intimately related to each other. Many 2D images are perspective views of 3D objects and scenes. When we try to relate a 2D image to its originating 3D objects/scene, we enter the realm of computer vision. Computer vision techniques are increasingly being used in computer graphics and animation. One may take the position that in a broad sense, image processing subsumes computer vision and computer graphics. Finally, to solve many important problems, it may be advantageous, or necessary to use multimodal (especially, audio and visual) information. In this talk, we shall give two examples of interconnections. First: very low bitrate video coding using a 3D model-based approach, which combines computer vision and computer graphics. Second: audio-visual speech recognition, which combines the audio and the visual modalities.

Biography: **Thomas S. Huang** received his BS from National Taiwan University, and SM and SC.D. from the Massachusetts Institute of Technology, all in Electrical Engineering. He was on the Faculties of MIT and Purdue University before joining the University of Illinois at Urbana-Champaign in 1980, where he is currently William L. Everitt Distinguished Professor of Electrical and Computer Engineering, Professor of the Center for Advanced Study, Research Professor at Coordinated Science Laboratories, and Cochair of the Human Computer Intelligent Interaction major research theme at the Beckman Institute for Advanced Science and Technology. Huang's research interests lie in the broad area of Information Technology, but especially Multidimensional and Multimodal Signal Processing, with applications to human computer interaction, and multimedia data indexing, retrieval, and mining. He has published 21 books and more than 600 journal and conference papers in 2D digital filtering, digital holography, image and video compression, multimodal human computer interfaces, and multimedia data retrieval. He is a member of the National Academy of Engineering, a Fellow of SPIE, OSA, IAPR, and IEEE; and has received numerous awards, including: IEEE Jack S. Kilby Signal Processing Medal (co-recipient with Arun Netravali), and the King-Sun Fu Prize of the Int'l. Association of Pattern Recognition.

Wednesday 18 January 8:30 to 9:15 am

Computational Imaging Methods for Functional Brain Mapping and Molecular Imaging



Richard M. Leahy, Univ. of Southern California

The combined revolutionary advances in recent years in molecular biology, imaging science and computing power make this a golden age for biomedical imaging. Central to modern biomedical imaging is the requirement for new computational imaging methods for noninvasive studies of human and animal anatomy and function. Computational tools are needed both for optimizing resolution and noise properties in

reconstructed images and for the interpretation and statistical analysis of these images across modalities, subjects, and populations. I will describe some recent work on image formation and analysis in functional brain mapping and molecular imaging, and attempt to highlight common themes and open research questions relevant to computational imaging.

Biography: **Richard M. Leahy** received the B.Sc. and Ph.D. degrees in Electrical Engineering from the University of Newcastle upon Tyne, England. In 1985 he joined the University of Southern California where he is a Professor of Electrical Engineering, Radiology and Biomedical Engineering and was Director of the Signal and Image Processing Institute from 1997 until 2003. He was General Chair of the 2004 IEEE International Symposium on Biomedical Imaging and is a Fellow of the IEEE. His research interests lie in the application of signal and image processing theory to anatomical and functional imaging with applications in neuroimaging, oncology, and gene expression.

General Information

Electronic Imaging 2006

San Jose Convention Center
408 S. Almaden Boulevard, San Jose, CA 95110

San Jose Marriott Hotel
301 S. Market Street, San Jose, CA 95113

Registration Location and Information Hours

San Jose Convention Center, Concourse 1 Lobby

Courses Only:

Sunday 15 January 7:00 am to 10:00 am

Conference Registration:

Sunday 15 January 10:00 am to 4:00 pm

Monday-Wednesday 16-18 January 7:00 am to 4:00 pm

Thursday 19 January 7:00 am to Noon

Speakers Audiovisual Desk Hours

San Jose Convention Center, Room E

Monday-Thursday 16-19 January 7:30 am to 4:30 pm

Speakers who have requested to use LCD projection from their laptop, 35mm slide projection, a VHS video player, or an overhead projector are encouraged to preview their materials at the Audiovisual Desk prior to their presentation. Speakers who have requested special equipment beyond the standard equipment noted here are asked to report to the EI '06 Audiovisual Desk upon arrival at the meeting to confirm equipment requests. Speakers will be responsible for delivering visual materials to the conference room and may retrieve their presentation materials from the room monitor in the conference room immediately following the session.

Course Notes

Courses will take place in various meeting rooms at the San Jose Marriott Hotel and the San Jose Convention Center. Your room assignment will be given to you with a ticket in your registration materials. Registrants for courses must exchange each course ticket received for their course notes in the course meeting room at the beginning of your class.

Video/Digital Recording Policy

For copyright reasons, video or digital recording of any conference session, short course, or poster session is strictly prohibited without written prior consent from each specific presenter to be recorded. Individuals not complying with this policy will be asked to leave a given session and to surrender their film or disc. It is the responsibility of the presenter to notify the conference sponsors if such consent is given.

Messages for Attendees

Messages for attendees at Electronic Imaging 2006 Symposium can be left by calling the IS&T/SPIE Message Center at 408-271-6100. Messages will be taken during registration hours Sunday through Thursday.

Attendees should check the message boards at the message center daily to receive their messages.

Complimentary Internet Wireless Access

IS&T/SPIE are pleased to provide complimentary wireless access to the Internet for all conference attendees bringing 802.11b wireless-enabled laptops or PDAs.

Properly secure your computer before accessing the public wireless network. Failure to do so may allow unauthorized access to your laptop.

Coverage locations and connection settings will be posted at the Registration desk.

Please configure your wireless settings as follows:

SSID: EI2006 (case-sensitive - all capital letters)

WEP: Disabled

Network Card Settings: DHCP

SPIE Bookstore and Membership Booth

Monday through Thursday, Open during registration hours.

SPIE publishes a variety of technical books designed to meet diverse research, reference, and educational needs. Proceedings of SPIE technical conferences from this and related meetings may be purchased at the bookstore. Also available are related books in the SPIE PRESS Series, including Tutorial Texts, Milestone Series of Selected Reprints, Critical Reviews in Science & Technology, and Monographs & Handbooks.

IS&T Bookstore and Membership Booth

Monday through Thursday, Open during registration hours.

IS&T publishes a variety of books to meet your needs. Proceedings of past IS&T conferences including Digital Printing Technologies, Color Imaging as well as Recent Progress series books will be available. IS&T also distributes selected titles from cooperating publishers of science and technology books in the imaging field. Information about upcoming IS&T conferences and IS&T membership benefits, sample journals, and newsletters are available.

Cash Cart: Breakfast Breads, Snacks and Quick Lunch

San Jose Convention Center, Concourse 1 Lobby

Monday-Thursday 16-19 January 7:30 am to 2:30 pm

The Cash Cart will offer breakfast breads, yogurt, fruit, coffee, juice and other beverages each morning of the conference. Luncheon and snack service will include deli-style sandwiches, salads, snacks and pastries, and beverage.

Attendees will need to make their own breakfast arrangements for Monday.

Copy & Computer Services

Marriott San Jose Hotel - Business Center. Self-service computers/printers, fax, copiers and internet access is available on 24 hr basis. Access is by your sleeping room key. All Marriott guest rooms include T-1 internet connections.

San Jose Convention Center - Business Center at the administration office. Open 8:00 am to 5:00 pm daily. Services available include computers/printers, fax, and copiers.

Child Care

A few child sitting services available in San Jose are as follows.

1. Bay Area 2nd MOM Inc.

Hotel Nanny Service

Toll Free Phone: 1-888-926-3666, or (650) 858-2469, ext. 109.,

Monday-Friday 9:00 am to 5:00 pm.

At other times phone (650) 858-4984

Fax: (650) 493-6598

E-mail: info@2ndmom.com or oncall@2ndmom.com

Website: www.2ndmom.com

2. Sitters Unlimited

Phone: (408) 452-0225

E-mail: rforosorio@peoplepc.com or www.sittersunlimited.com

Note: IS&T/SPIE does not imply an endorsement or recommendation of these services. They are provided on an "information-only" basis for your further analysis and decision. Other services may be available.

Car Rental



Hertz Car Rental has been selected as the official car rental agency for this Symposium. To reserve a car, identify yourself as an Electronic Imaging Conference attendee using the Hertz Meeting Code CV# 029B0009. Call 1-800-654-2240.

Conference 6055A • Conv. Ctr. Room A8

Monday-Wednesday 16-18 January 2006 • Part of Proceedings of SPIE Vol. 6055
Stereoscopic Displays and Virtual Reality Systems XIII

Stereoscopic Displays and Applications XVII

Conference Chairs: **Andrew J. Woods**, Ctr. for Marine Science and Technology/Curtin Univ. of Technology (Australia); **Neil A. Dodgson**, Univ. of Cambridge (United Kingdom); **John O. Merritt**, The Merritt Group

Program Committee: **Gregg E. Favalora**, Actuality Systems, Inc.; **Nicolas S. Holliman**, Univ. of Durham (United Kingdom); **Janusz Konrad**, Boston Univ.; **Shojiro Nagata**, InterVision (Japan); **Steven L. Smith**, Consultant; **Vivian K. Walworth**, Jasper Associates; **Michael A. Weissman**, Micro Vision Systems Inc.

Monday 16 January

SESSION 1

Conv. Ctr. Room A8 Mon. 8:30 to 10:10 am

Entertainment, Visualization, and Training: Applications of Stereoscopy

Chair: **Andrew J. Woods**, Curtin Univ. of Technology (Australia)

8:30 am: **The use of stereoscopic visualization in chemistry and structural biology**, M. Hušák, Institute of Chemical Technology Prague (Czech Republic) [6055A-01]

8:50 am: **Using stereoscopic real-time graphics to shorten training time for complex mechanical tasks**, F. Tecchia, M. Carrozzino, F. Rossi, M. Bergamasco, Scuola Superiore Sant'Anna (Italy); M. Vescovi, SIG Simonazzi (Italy) [6055A-02]

9:10 am: **Stereoscopic display of 3D models for design visualization**, K. J. Gilson, Parsons Brinckerhoff [6055A-03]

9:30 am: **Stereoscopic image production: live, CGI, and integration**, E. Criado, Enxebre Entertainment (Spain) [6055A-04]

9:50 am: **Cosmic cookery: making a stereoscopic 3D animated movie**, N. S. Holliman, C. Baugh, C. Frenk, A. Jenkins, B. Froner, D. Hassaine, J. Helly, N. Metcalfe, T. Okamoto, Univ. of Durham (United Kingdom) [6055A-05]

Coffee Break 10:10 to 10:40 am

SESSION 2

Conv. Ctr. Room A8 Mon. 10:40 am to 12:00 pm

Medical Applications of Stereoscopy

Chair: **Michael A. Weissman**, Micro Vision Systems, Inc.

10:40 am: **Evaluation of stereoscopic medical video content on an autostereoscopic display for undergraduate medical education**, J. F. R. Ilgner, Univ. Hospital Aachen (Germany); T. Kawai, T. Shibata, T. Yamazoe, Waseda Univ. (Japan); M. Westhofen, Univ. Hospital Aachen (Germany) [6055A-06]

11:00 am: **Stereoscopic visualization and editing of automatic abdominal aortic aneurysms (AAA) measurements for stent graft planning**, L. Zhou, Y. P. Wang, C. Goh, R. Kockro, L. Serra, Volume Interactions Pte. Ltd. (Singapore) [6055A-07]

11:20 am: **A hybrid virtual environment for training of radiotherapy treatment of cancer.**, R. Phillips, The Univ. of Hull (United Kingdom) [6055A-08]

11:40 am: **Blur spot limitations in distal endoscope sensors**, A. Yaron, Visionsense Inc.; M. Shechterman, N. Horesh, U. Ronen, Visionsense Ltd. (Israel) [6055A-09]

Lunch Break 12:00 to 1:30 pm

SESSION 3

Conv. Ctr. Room A8 Mon. 1:30 to 3:10 pm

Perception and Performance: Stereoscopic Human Factors

Chair: **John O. Merritt**, The Merritt Group

1:30 pm: **Visual comfort with mobile stereoscopic gaming**, J. P. Häkkinen, Nokia Research Ctr. (Finland) and Univ. of Helsinki (Finland); M. Liinasuo, Nokia Research Ctr. (Finland); J. Takatalo, G. S. Nyman, Univ. of Helsinki (Finland) [6055A-10]

1:50 pm: **Effect of disparity and motion on visual comfort of stereoscopic images**, F. Speranza, J. W. Tam, R. Renaud, Communications Research Ctr. Canada (Canada); N. Hur, Electronics and Telecommunications Research Institute (South Korea) [6055A-11]

2:10 pm: **Analysis of an autostereoscopic display: the perceptual range of the three-dimensional visual fields and saliency of static depth cues**, P. R. Havig, Air Force Research Lab.; J. P. McIntire, Consortium Research Fellows Program; R. McGruder, U.S. Air Force Academy [6055A-12]

2:30 pm: **Effects of gender, application, experience, and constraints on interaction performance using autostereoscopic displays**, Z. Y. Alpaslan, S. Yeh, A. A. Rizzo III, A. A. Sawchuk, Univ. of Southern California [6055A-13]

2:50 pm: **Examination of asthenopia recovery using stereoscopic 3D display with dynamic optical correction**, T. Shibata, T. Kawai, K. Ohta, L. Jae Lin, Waseda Univ. (Japan); M. Otsuki, N. Miyake, Nikon Corp. (Japan); Y. Yoshihara, Arisawa Manufacturing Co., Ltd. (Japan); T. Iwasaki, Univ. of Occupational and Environmental Health (Japan) [6055A-14]

Coffee Break 3:10 to 3:40 pm

SESSION 4

Conv. Ctr. Room A8 Mon. 3:40 to 5:00 pm

Stereoscopic Projection and Stereoscopic Cinema

Chair: **Vivian K. Walworth**, Jasper Associates

3:40 pm: **High-resolution insets in projector-based stereoscopic displays: principles and techniques**, G. Godin, P. Massicotte, L. Borgeat, National Research Council Canada (Canada) [6055A-15]

4:00 pm: **Stereo projection using interference filters**, H. Jorke, M. Fritz, Infitec GmbH (Germany) [6055A-16]

4:20 pm: **Development of the real-time stereoscopic error corrector and convergence controller**, S. Nam, C. Park, Korean Broadcasting System (South Korea); Y. S. Yu, K. Lee, TVLogic Co. Ltd. (South Korea) [6055A-55]

4:40 pm: **3D in digital cinema**, W. J. Husak, Dolby Labs. [6055A-18]

Conference 6055A • Co nv. Ctr. Room A8

3D Theatre 5:20 to 7:20 pm

*Chairs: Andrew J. Woods, Curtin Univ. of Technology (Australia);
Chris Ward, Lightspeed Design, Inc.*

See large-screen examples of how 3D video is being used and produced around the world.

SD&A Dinner 7:30 pm to Late

A no-host informal dinner open to all SD&A attendees will be held at a local San Jose restaurant. Details will be available at the conference.

Tuesday 17 January

Plenary Speaker Tues. 8:30 to 9:15 am

Marriott Ballroom 1-6

Image Processing: Interconnections

Thomas S. Huang, Beckman Institute for Advanced Science and Technology, Univ. of Illinois at Urbana-Champaign

See p. 7 for details.

SESSION 5

Conv. Ctr. Room A8 Tues. 9:30 to 10:30 am

Stereoscopic Image Processing

Chair: Janusz Konrad, Boston Univ.

9:30 am: **Platelet-based coding of depth maps for the transmission of multiview images**, Y. Morvan, D. Farin, P. H. N. de With, Technische Univ. Eindhoven (Netherlands) [6055A-19]

9:50 am: **Efficient view synthesis from uncalibrated stereo**, R. A. C. Braspenning, M. Op de Beeck, Philips Research Labs. (Netherlands) [6055A-20]

10:10 am: **A fast image multiplexing method robust to viewer's position and lens misalignment in lenticular 3D displays**, Y. Lee, J. B. Ra, Korea Advanced Institute of Science and Technology (South Korea) [6055A-21]

Coffee Break 10:30 to 11:00 am

SESSION 6

Conv. Ctr. Room A8 Tues. 11:00 am to 12:00 pm

Making Pictures: Stereoscopic Rendering

Chair: Neil A. Dodgson, Univ. of Cambridge (United Kingdom)

11:00 am: **Real-time rendering for multiview displays**, R. M. Berretty, F. J. Peters, Philips Research Labs. (Netherlands); G. Volleberg, Philips Applied Technologies (Netherlands) [6055A-22]

11:20 am: **Anisotropic scene geometry resampling with occlusion filling for 3DTV applications**, J. Kim, T. Sikora, Technische Univ. Berlin (Germany) [6055A-23]

11:40 am: **Distributed rendering for multiview parallax displays**, T. Annen, Max-Planck-Institut für Informatik (Germany); W. Matusik, H. Pfister, Mitsubishi Electric Research Labs.; H. Seidel, Max-Planck-Institut für Informatik (Germany); M. Zwicker, Massachusetts Institute of Technology [6055A-24]

Lunch/Exhibition Break 12:00 to 1:30 pm

SESSION 7

Conv. Ctr. Room A8 Tues. 1:30 to 3:10 pm

Autostereoscopic Displays I

Chair: Gregg E. Favalora, Actuality Systems, Inc.

1:30 pm: **On the number of viewing zones required for head-tracked autostereoscopic display**, N. A. Dodgson, Univ. of Cambridge (United Kingdom) [6055A-25]

1:50 pm: **Multiview LCD wall system**, I. Relke, Opticality GmbH (Germany) [6055A-26]

2:10 pm: **Flatbed-type autostereoscopic display system and its image format for encoding**, T. Saishu, S. Numazaki, K. Taira, R. Fukushima, A. Morishita, Y. Hirayama, Toshiba Corp. (Japan) [6055A-27]

2:30 pm: **Autostereoscopic 3D display**, A. Schwerdtner, SeeReal Technologies GmbH (Germany) [6055A-28]

2:50 pm: **The HoloVizio system**, T. Balogh, Holografika Kft. (Hungary) [6055A-29]

Coffee Break 3:10 to 3:40 pm

SESSION 8

Conv. Ctr. Room A8 Tues. 3:40 to 5:20 pm

Autostereoscopic Displays II

Chair: Shojiro Nagata, InterVision (Japan)

3:40 pm: **Development of autostereoscopic display system for remote manipulation**, T. Honda, Y. Kuboshima, K. Iwane, T. Shiina, Chiba Univ. (Japan) [6055A-30]

4:00 pm: **Ray-space acquisition and reconstruction within cylindrical objective space**, T. Yendo, T. Fujii, M. Tanimoto, Nagoya Univ. (Japan) [6055A-31]

4:20 pm: **72-directional display having VGA resolution for high-appearance image generation**, Y. Takaki, T. Dairiki, Tokyo Univ. of Agriculture and Technology (Japan) [6055A-32]

4:40 pm: **Combining volumetric edge display and multiview display for expression of natural 3D images**, R. Yasui, I. Matsuda, H. Kakeya, Univ. of Tsukuba (Japan) [6055A-33]

5:00 pm: **Adaptive parallax control for multiview stereo panoramas**, C. Wang, A. A. Sawchuk, Univ. of Southern California [6055A-34]

✓ Posters and Demonstrations-Tuesday

*Chairs: Neil A. Dodgson, Univ. of Cambridge (United Kingdom);
Andrew J. Woods, Curtin Univ. of Technology (Australia)*

Demonstrations 5:30 to 8:30 pm

A symposium-wide demonstration session will be open to attendees 5:30 to 8:30 pm Tuesday evening in Conv. Ctr. Exhibit Hall 1.

Demonstrators will provide interactive, hands-on demonstrations of a wide-range of products related to Electronic Imaging.

Posters 5:30 to 7:00 pm

Posters will be placed on display after 10:00 am in Exhibit Hall 1. A poster session, with authors present at their posters, will be held Tuesday evening, 5:30 to 7:00 pm.

✓ **Real-time stereographic display of volumetric datasets in radiology**, X. H. Wang, G. S. Maitz, J. K. Leader, W. F. Good, Univ. of Pittsburgh [6055A-46]

✓ **Ergonomic evaluation system for stereoscopic video production**, T. Kawai, S. Kishi, T. Yamazoe, T. Shibata, Waseda Univ. (Japan); T. Inoue, Kanagawa Institute of Technology (Japan); Y. Sakaguchi, K. Okabe, Y. Kuno, Let's Corp. (Japan); T. Kawamoto, Chukyo TV Broadcasting Corp. (Japan) [6055A-47]

✓ **Wide-viewing-angle three-dimensional display system using HOE lens array**, H. Takahashi, H. Fujinami, Osaka City Univ. (Japan); K. Yamada, Hiroshima Institute of Technology (Japan) [6055A-48]

Conference 6055A • Conv. Ctr. Room A8

- ✓ **Depth map-based disparity estimation technique using multiview and depth camera**, G. Um, Electronics and Telecommunications Research Institute (South Korea); S. Kim, K. Kim, Gwangju Institute of Science and Technology (South Korea); N. Hur, Electronics and Telecommunications Research Institute (South Korea); K. Lee, Gwangju Institute of Science and Technology (South Korea) [6055A-50]
- ✓ **A uniform metric for anaglyph calculation**, Z. Zhang, D. F. McAllister, North Carolina State Univ. [6055A-51]
- ✓ **Multiview autostereoscopic display with double-sided reflecting scanning micromirrors**, A. Nakai, K. Hoshino, K. Matsumoto, I. Shimoyama, The Univ. of Tokyo (Japan) [6055A-53]
- ✓ **Depth-enhanced floating display system based on integral imaging**, J. Kim, Seoul National Univ. (South Korea); S. Min, Information and Communications Univ. (South Korea); Y. Kim, S. Cho, H. Choi, B. Lee, Seoul National Univ. (South Korea) [6055A-54]
- ✓ **Three-dimensional sprites for lenticular-type three-dimensional display**, T. Dairiki, Y. Takaki, Tokyo Univ. of Agriculture and Technology (Japan) [6055A-56]
- ✓ **Optical design considerations for a beam combiner in a StereoMirror (TM) 3D display**, A. Hochbaum, VAV Consulting; J. L. Ferguson, Ferguson Patent Properties [6055A-57]
- ✓ **Horizontal parallax distortion in toe-in camera systems with fisheye lens**, H. Kang, D. Kim, N. Hur, Electronics and Telecommunications Research Institute (South Korea) [6055A-58]
- ✓ **Implementation of 3DTV broadcasting system for realistic broadcasting services**, B. Bae, S. Cho, K. Yun, H. Kang, N. Hur, C. Ahn, Electronics and Telecommunications Research Institute (South Korea) [6055A-59]
- ✓ **Performance analysis of a compact electro-optical 3D adapter with a wide capturing angle**, S. Kim, J. Lee, E. Kim, Kwangwoon Univ. (South Korea) [6055A-61]
- ✓ **New method of zoom-convergence interlocked control in the moving parallel-axes style stereoscopic camera**, J. Lee, S. Nam, J. Lee, C. Park, S. Chung, Korean Broadcasting System (South Korea) [6055A-62]

Wednesday 18 January

Plenary Speaker **Wed. 8:30 to 9:15 am**

Marriott Ballroom 1-6

Computational Imaging Methods for Functional Brain Mapping and Molecular Imaging

Richard Leahy, Univ. of Southern California

See p. 7 for details.

SESSION 9

Conv. Ctr. Room A8 **Wed. 9:30 to 10:30 am**

Integral 3D Imaging

Chair: Shojiro Nagata, InterVision (Japan)

9:30 am: **Integral videography of high-density light field with spherical layout camera array**, T. Koike, M. Oikawa, N. Kimura, F. Beniyama, T. Moriya, M. Yamasaki, Hitachi, Ltd. (Japan) [6055A-35]

9:50 am: **Imaging properties of microlens arrays for integral imaging system**, J. Arai, M. Okui, Y. Nojiri, F. Okano, NHK Science & Technical Research Labs. (Japan) [6055A-36]

10:10 am: **Comparative study on 3D-2D convertible integral imaging systems**, B. Lee, H. Choi, J. Kim, Y. Kim, Seoul National Univ. (South Korea) [6055A-37]

Coffee Break 10:30 to 11:00 am

Discussion Forum: Stereoscopic Digital Cinema: The Way of the Future or a 9-Day Wonder?

Moderator: Charles Swartz, Entertainment Technology Ctr./Univ. of Southern California

Panel Members: Lenny Lipton, CTO, REAL D; Ray Zone, The 3-D Zone; John Rupkalvis, StereoScope International; Walter Husak, Dolby Labs Inc.; Neil Feldman, In-Three, Inc.

Lunch/Exhibition Break 12:00 to 1:50 pm

SESSION 10

Conv. Ctr. Room A8 **Wed. 1:50 to 2:10 pm**

Stereoscopic Software

Chair: Nicolas S. Holliman, Univ. of Durham (United Kingdom)

1:50 pm: **Application of 3DHivision: a system with a new 3D HD renderer**, P. Sun, Sun Advanced Engineering, Inc. (Japan); S. Nagata, InterVision (Japan) [6055A-39]

SESSION 11

Conv. Ctr. Room A8 Wed. 2:20 to 3:20 pm

Keynote Presentation

Chair: Andrew J. Woods, Curtin Univ. of Technology (Australia)

Keynote

3D animation in three dimensions: the rocky road to the obvious, Hugh Murray, IMAX Corp. (Canada) [6055A-40]

That animation created using CG modeling and animation tools is inherently three-dimensional is well known. In the middle to late nineties IMAX Corporation began actively exploring CG animated features as a possible source of economically viable content for its rapidly growing network of stereoscopic IMAX(r) 3D theatres. The journey from there to the spectacular success of the IMAX(r) 3D version of The Polar Express is an interesting mix of technical, creative and production challenges. For example 3D animations often have 2D elements and include many sequences that have framing, composition and lens choices that a stereographer would have avoided had 3D been part of the recipe at the outset. And of course the decision to ask for a second set of deliverables from an already stressed production takes nerve. The talk will cover several of these issues and explain why the unique viewing experience enabled by the wide-angle geometry of IMAX(r) 3D theatres makes it worth all the pain.

Biography: **Hugh Murray** is Vice President, Technical Production at IMAX Corporation and for the past 10 years he has worked on most of IMAX Corporation's film productions as a technical expert, particularly in 3D and special effects. Hugh was the instigator and producer, with Steve Hoban, of the computer animated film Cyberworld 3D. Hugh led the team that identified the key technologies for the IMAX DMR(r) process and was IMAX(r) Producer on Apollo 13 (with Lorne Orleans), Star Wars Episode II: Attack of the Clones (with Lorne Orleans), Matrix Reloaded, Matrix Revolutions, and the IMAX(r) 3D version of The Polar Express. He was most recently an Executive Producer on Magnificent Desolation: Walking On The Moon 3D and is currently working on the 3D versions of two animated features for release in 2006.

Coffee Break 3:20 to 3:50 pm

SESSION 12

Conv. Ctr. Room A8 Wed. 3:50 to 5:30 pm

Stereoscopic Developments

Chair: Steven L. Smith, Consultant

3:50 pm: **A method of real-time construction of full parallax light field**, K. Tanaka, S. Aoki, Sony Corp. (Japan) [6055A-41]

4:10 pm: **Depth maps created from blur information using images with focus at near and at far**, S. Cho, Electronics and Telecommunications Research Institute (South Korea); J. W. Tam, F. Speranza, R. Renaud, Communications Research Ctr. Canada (Canada); N. Hur, S. Lee, Electronics and Telecommunications Research Institute (South Korea) [6055A-49]

4:30 pm: **Simulation of 3D image depth perception in a 3D display using two stereoscopic displays at different depths**, K. Uehira, Kanagawa Institute of Technology (Japan) [6055A-43]

4:50 pm: **Innovative stereoscopic display using variable polarized angle**, J. E. Gaudreau, PolarScreens, Inc. (Canada) and MacNaughton, Inc.; M. Bechamp, PolarScreens, Inc. (Canada); B. MacNaughton, V. S. Power, MacNaughton, Inc. [6055A-44]

5:10 pm: **A novel walk-through 3D display**, S. DiVerdi, A. Olwal, I. K. Rakkolainen, T. Höllerer, Univ. of California/Santa Barbara ... [6055A-45]

Conference 6055B • Conv. Ctr. Room B3

Thursday 19 January 2006 • Part of Proceedings of SPIE Vol. 6055
Stereoscopic Displays and Virtual Reality Systems XIII

The Engineering Reality of Virtual Reality 2006

Conference Chairs: **Mark T. Bolas**, Univ. of Southern California; **Ian E. McDowall**, Fakespace Labs., Inc.

Program Committee: **Nick England**, 3rdTech, Inc.; **Guillaume Moreau**, CNRS Aeronmie (France); **Shojiro Nagata**, InterVision (Japan); **Daniel J. Sandin**, Univ. of Illinois/Chicago; **Andreas Simon**, Fraunhofer Institute for Media Communication (Germany); **Henry A. Sowizral**, Sun Microsystems, Inc.

Thursday 19 January

SESSION 13

Conv. Ctr. Room B3 Thurs. 8:30 to 9:50 am

Procedures

Chair: **Ian E. McDowall**, Fakespace Labs., Inc.

- 8:30 am: **Texturing of continuous LoD meshes with the hierarchical texture atlas**, H. Birkholz, Univ. Rostock (Germany) [6055B-63]
- 8:50 am: **Optimal approximation of head-related transfer function's zero-pole model based on genetic algorithm**, J. Zhang, Southeast Univ. (China) [6055B-64]
- 9:10 am: **Multiprojector image distortion correction scheme for curved screens on the example of the Cybersphere**, B. V. Shulgin, J. Ye, V. H. Raja, Univ. of Warwick (United Kingdom) [6055B-65]
- 9:30 am: **3D workflow for HDR image capture of projection systems and objects for CAVE virtual environments authoring with wireless touch-sensitive devices**, M. J. Prusten, Optical Design Labs.; M. K. McIntyre, Total Eclipse Studios; M. Landis, The Univ. of Arizona [6055B-66]
- Coffee Break 9:50 to 10:20 am

SESSION 14

Conv. Ctr. Room B3 Thurs. 10:20 to 11:40 am

Applications

Chair: **Ian E. McDowall**, Fakespace Labs., Inc.

- 10:20 am: **Examination of corner vane estrangement evaluation method for a circular tunnel**, H. Yokoyama, O. Fujishima, Hitachi, Ltd. (Japan) [6055B-67]
- 10:40 am: **Virtual technical support for field engineers in the water and ventilation hygiene industry**, I. A. Nicholas, Cardiff Univ. (United Kingdom); D. Kim, Aqua Marc Ltd. (United Kingdom) [6055B-68]
- 11:00 am: **Virtual reality in construction industry: a requirement compatibility analysis approach**, J. Ye, B. V. Shulgin, V. H. Raja, Univ. of Warwick (United Kingdom) [6055B-69]
- 11:20 am: **Adding tactile realism to a virtual reality laparoscopic surgical simulator with a cost-effective human interface device**, I. W. Mack, Queen's Univ. Belfast (United Kingdom); S. Potts, The Royal Group of Hospitals (United Kingdom); K. R. McMenemy, R. S. Ferguson, Queen's Univ. Belfast (United Kingdom) [6055B-70]
- Lunch Break 11:40 am to 1:10 pm

SESSION 15

Conv. Ctr. Room B3 Thurs. 1:10 to 2:30 pm

The Medium

Chair: **Mark T. Bolas**, Fakespace Labs., Inc.

- 1:10 pm: **Inverse perspective**, M. Dolinsky, Indiana Univ. [6055B-71]
- 1:30 pm: **Virtual reality and the unfolding of higher dimensions**, J. C. Aguilera, Univ. of Illinois at Chicago [6055B-72]
- 1:50 pm: **Framing the magic**, D. Tsoupikova, Univ. of Illinois at Chicago [6055B-73]
- 2:10 pm: **Virtual reality, immersion, and the unforgettable experience**, J. F. Morie, Univ. of Southern California [6055B-74]

SESSION 16

Conv. Ctr. Room B3 Thurs. 2:30 to 4:40 pm

Viewpoints

Chair: **Mark T. Bolas**, Fakespace Labs., Inc.

- 2:30 pm: **Teleoperation interface for mobile robot with perspective-transformed virtual 3D screen on PC display**, T. Kimura, H. Kakeya, Univ. of Tsukuba (Japan) [6055B-75]
- 2:50 pm: **An orientation sensing interface for portable situation awareness displays**, J. Bleecker, Univ. of Southern California [6055B-76]
- Coffee Break 3:10 to 3:40 pm
- 3:40 pm: **An interactive camera placement and visibility simulator for image-based VR applications**, A. State, G. Welch, A. Ilie, The Univ. of North Carolina at Chapel Hill [6055B-77]
- 4:00 pm: **Overview of virtual camera mechanisms for collaborative virtual environments: an application to the VRIMOR project**, E. E. Alvarez, A. A. De Antonio, Univ. Politécnic de Madrid (Spain) [6055B-78]
- 4:20 pm: **Syntheticology: 'sound' use of audio in teleimmersion**, G. A. Baum, SUNY/Univ. at Buffalo; M. Gotsis, Univ. of Southern California; B. Chang, R. Drinkwater, D. St. Clair, Art Institute of Chicago ... [6055B-79]

Panel Discussion 4:40 to 5:40 pm

Conference 6056 • Conv. Ctr. Room C1

Monday-Tuesday 16-17 January 2006 • Proceedings of SPIE Vol. 6056

Three-Dimensional Image Capture and Applications VI

Conference Chairs: **Brian D. Corner**, U.S. Army Natick Soldier Ctr.; **Peng Li**, GEO-Centers, Inc.; **Matthew Tocheri**, Arizona State Univ.

Monday 16 January

SESSION 1

Conv. Ctr. Room C1 Mon. 8:40 to 10:00 am

3D Scanning Hardware

Chair: **Brian D. Corner**, U.S. Army Natick Soldier Ctr.

8:40 am: **A novel design of grating projecting system for 3D reconstruction of wafer bumps**, Y. Shu, Xi'an Jiaotong Univ. (China); R. C. Chung, J. Cheng, The Chinese Univ. of Hong Kong (Hong Kong China); E. Y. Lam, The Univ. of Hong Kong (Hong Kong China); K. S. M. Fung, F. Wang, ASM Assembly Automation Ltd. (Hong Kong China) [6056-01]

9:00 am: **Measurement of discontinuities on 3D objects using digital moiré**, J. Liao, L. Cai, The Hong Kong Univ. of Science and Technology (Hong Kong China) [6056-02]

9:20 am: **High-speed and high-sensitive demodulation pixel for 3D imaging**, B. Büttgen, T. Oggier, Ctr. Suisse d'Electronique et de Microtechnique SA (Switzerland); P. Seitz, Swissnex; F. Lustenberger, Ctr. Suisse d'Electronique et de Microtechnique SA (Switzerland) ... [6056-03]

9:40 am: **A QVGA-size CMOS time-of-flight range image sensor with background light charge draining structure**, T. Ushinaga, I. Abdul Halin, T. Sawada, S. Kawahito, Shizuoka Univ. (Japan); M. Homma, Sharp Corp. (Japan); Y. Maeda, Suzuki Motor Corp. (Japan) [6056-04]

Coffee Break 10:00 to 10:30 am

SESSION 2

Conv. Ctr. Room C1 Mon. 10:30 am to 12:00 pm

3D Object Capture from Static Scans and Video I

Chair: **Brian D. Corner**, U.S. Army Natick Soldier Ctr.

10:30 am: **Overview of 3D surface digitization technologies in Europe (Invited Paper)**, N. D'Apuzzo, Homometrica Consulting (Switzerland) [6056-05]

11:00 am: **Automatic 3D real world surface texture mapping using perspective projection methods**, C. Shih, MingDao Univ. (Taiwan) [6056-06]

11:20 am: **Virtual confocal macroscopy**, P. M. Hanna, U.S. Air Force; B. D. Rigling, Wright State Univ. [6056-07]

11:40 am: **A robust algorithm for estimation of depth map for 3D shape recovery**, A. Malik, T. Choi, Gwangju Institute of Science and Technology (South Korea) [6056-08]

Lunch Break 12:00 to 1:30 pm

SESSION 3

Conv. Ctr. Room C1 Mon. 1:30 to 5:00 pm

3D Object Capture from Static Scans and Video II

Chair: **Peng Li**, GEO-Centers, Inc.

1:30 pm: **Formation of stereoscopic image pairs from a sequence of frames**, M. A. Wessels, Dimensional Imaging, LLC [6056-09]

1:50 pm: **3D model generation using unconstrained motion of a handheld video camera**, C. Baker, C. H. Debrunner, M. Whitehorn, PercepTek, Inc. [6056-10]

2:10 pm: **3D from arbitrary 2D video**, I. A. Ideses, L. P. Yaroslavsky, Tel-Aviv Univ. (Israel) [6056-11]

2:30 pm: **Nonintrusive viewpoint tracking for 3D for perception in smart video conference**, X. Desurmont, I. Ponte, J. Meessen, J. Delaigle, Multitel A.S.B.L. (Belgium) [6056-12]

2:50 pm: **Internal shape-deformation invariant 3D surface matching using 2D principal component analysis**, M. Celenk, I. Al-Jarrah, Ohio Univ. [6056-13]

Coffee Break 3:10 to 3:40 pm

3:40 pm: **Digital Hammurabi: design and development of a 3D scanner for cuneiform tablets**, D. V. Hahn, D. Duncan, K. Baldwin, J. Cohen, B. Purnomo, Johns Hopkins Univ. [6056-14]

4:00 pm: **Three-dimensional surface reconstruction for evaluation of the abrasion effects on textile fabrics**, A. O. Mendes, P. T. Fiadeiro, R. A. Miguel, Univ. da Beira Interior (Portugal) [6056-15]

4:20 pm: **3D environment capture from monocular video and inertial data**, R. Clark, M. Lin, C. J. Taylor, Acuity Technology [6056-16]

4:40 pm: **The effects of different shape-based metrics on identification of military targets from 3D lidar data**, G. J. Meyer, J. Weber, Air Force Research Lab. [6056-18]

Tuesday 17 January

Plenary Speaker Tues. 8:30 to 9:15 am

Marriott Ballroom 1-6

Image Processing: Interconnections

Thomas S. Huang, Beckman Institute for Advanced Science and Technology, Univ. of Illinois at Urbana-Champaign

See p. 7 for details.

SESSION 4

Conv. Ctr. Room C1 Tues. 9:30 am to 12:10 pm

3D Scans of the Human I

Chair: **Matthew Tocheri**, Arizona State Univ.

9:30 am: **Digital 3D reconstruction of George Washington (Invited Paper)**, A. Razdan, Arizona State Univ. [6056-19]

10:00 am: **The study of craniofacial growth patterns using 3D laser scanning and geometric morphometrics**, M. Friess, Anthrotech Inc. [6056-20]

Coffee Break 10:20 to 10:50 am

Conference 6056 • Conv. Ctr. Room C1

10:50 am: **A three-dimensional analysis of the geometry and curvature of the proximal tibial articular surface of hominoids**, E. K. Landis, P. A. Karnick, Arizona State Univ.[6056-21]
11:10 am: **New approach in curve matching technique and its implications on human evolution research**, H. Vahdati, P. A. Karnick, Arizona State Univ.[6056-22]
11:30 am: **Point cloud-based 3D head model classification using optimized EGI**, X. Tong, H. Wong, B. Ma, City Univ. of Hong Kong (Hong Kong China)[6056-23]
11:50 am: **3D face structure extraction using shape matching morphing model**, F. Xue, X. Ding, Tsinghua Univ. (China)[6056-24]
Lunch/Exhibition Break 12:10 to 1:40 pm

SESSION 5

Conv. Ctr. Room C1 Tues. 1:40 to 2:40 pm

3D Scans of the Human II

Chair: Brian D. Corner, U.S. Army Natick Soldier Ctr.

1:40 pm: **Posture and re-positioning considerations of a torso imaging system for assessing scoliosis**, P. O. Ajemba, N. G. Durdle, Univ. of Alberta (Canada); D. L. Hill, J. V. Raso, Glenrose Rehabilitation Hospital (Canada)[6056-25]
2:00 pm: **Reverse engineering and rapid prototyping techniques to innovate prosthesis socket design**, G. Magrassi, G. Colombo, M. Bertetti, D. Bonacini, Politecnico di Milano (Italy)[6056-26]
2:20 pm: **Measuring human movement for biomechanical applications using markerless motion capture**, L. Mündermann, S. Corazza, A. M. Chaudhari, T. P. Andriacchi, Stanford Univ.; A. Sundaresan, R. Chellappa, Univ. of Maryland/College Park[6056-28]

Posters and Demonstrations-Tuesday

Chair: Peng Li, GEO-Centers, Inc.

Demonstrations 5:30 to 8:30 pm

A symposium-wide demonstration session will be open to attendees 5:30 to 8:30 pm Tuesday evening in Conv. Ctr. Exhibit Hall 1. Demonstrators will provide interactive, hands-on demonstrations of a wide-range of products related to Electronic Imaging.

Posters 5:30 to 7:00 pm

Posters will be placed on display after 10:00 am in Exhibit Hall 1. A poster session, with authors present at their posters, will be held Tuesday evening, 5:30 to 7:00 pm.

- ✓ **Development of measurement system of three-dimensional shape and surface reflectance**, T. Miyasaka, K. Araki, Chukyo Univ. (Japan)[6056-29]
- ✓ **Use of laser 3D digitizer in data collection and 3D modeling of anatomical structures**, K. Tse, Univ. of New South Wales (Australia); H. Van Der Wall, Concord Repatriation General Hospital (Australia); D. H. Vu, Univ. of New South Wales (Australia)[6056-30]
- ✓ **Volume intersection with imprecise camera parameters**, S. Sakamoto, K. Shoji, H. Iwase, F. Toyama, J. Miyamichi, Utsunomiya Univ. (Japan)[6056-31]
- ✓ **Development of ultrathin three-dimensional image capturing system**, K. Yamada, H. Mitsui, T. Asano, Hiroshima Institute of Technology (Japan); H. Takahashi, Osaka City Univ. (Japan); J. Tanida, Osaka Univ. (Japan)[6056-32]

- ✓ **Run-based volume intersection for shape recovery of objects from their silhouettes**, K. Shoji, S. Sakamoto, H. Iwase, F. Toyama, J. Miyamichi, Utsunomiya Univ. (Japan)[6056-33]
- ✓ **A prototype system for 3D measurement using flexible calibration method**, M. Fukuda, T. Miyasaka, K. Araki, Chukyo Univ. (Japan)[6056-34]
- ✓ **Estimation of object motion with known structure in moving camera**, H. J. Kwon, N. Hur, S. Lee, Electronics and Telecommunications Research Institute (South Korea)[6056-35]
- ✓ **Synthesizing wide-angle and arbitrary view-point images from a circular camera array**, N. Fukushima, T. Yendo, T. Fujii, M. Tanimoto, Nagoya Univ. (Japan)[6056-36]
- ✓ **3D urban scene reconstruction from high-resolution IKONOS stereo images**, M. Fedi, T. Riadh, B. Ziad, SUPCOM (Tunisia)[6056-37]
- ✓ **Procedure and algorithm of 3D reconstruction of large-scale ancient architecture**, S. Xia, Y. Zhu, X. Li, Wuhan Univ. (China)[6056-38]
- ✓ **Real-time 3D image-guided patient positioning in radiation therapy**, D. Liu, Henry Ford Health System; G. Yin, Genex Technologies, Inc. (China); S. Li, Henry Ford Health System[6056-41]

Conference 6057 • Conv. Ctr. Room A3

Monday-Thursday 16-19 January 2006 • Proceedings of SPIE Vol. 6057

Human Vision and Electronic Imaging XI

Conference Chairs: **Bernice E. Rogowitz**, IBM Thomas J. Watson Research Ctr.; **Thrasylvoulos N. Pappas**, Northwestern Univ.; **Scott J. Daly**, Sharp Labs. of America, Inc.

Program Committee: **Albert J. Ahumada, Jr.**, NASA Ames Research Ctr.; **Jan P. Allebach**, Purdue Univ.; **Walter R. Bender**, MIT Media Lab.; **Michael H. Brill**, Datacolor; **John C. Dalton**, Synthetik Software; **Huib de Ridder**, Technische Univ. Delft (Netherlands); **Gunilla A. M. Derefeldt**, Swedish Defence Research Agency (Sweden); **Miguel P. Eckstein**, Univ. of California/Santa Barbara; **Elena A. Fedorovskaya**, Eastman Kodak Co.; **Jennifer Gille**, Raytheon Co.; **Laurent Itti**, Univ. of Southern California; **Stanley A. Klein**, Univ. of California/Berkeley; **Jan J. Koenderink**, Univ. Utrecht (Netherlands); **John J. McCann**, McCann Imaging; **Jeffrey B. Mulligan**, NASA Ames Research Ctr.; **Karol Myszkowski**, Max-Planck-Institut für Informatik (Germany); **Adar Pelah**, The Univ. of York (United Kingdom); **Hawley K. Rising III**, Sony Electronics; **Robert J. Safraneck**, Benevue, Inc.; **Christopher W. Tyler**, Smith-Kettlewell Institute; **Andrew B. Watson**, NASA Ames Research Ctr.

Note: Please see room sign for papers added after program was printed.

Monday 16 January

SESSION 1

Conv. Ctr. Room A3 Mon. 9:00 am to 12:00 pm

Keynote Session

10:00 am: **Computational Neuroimaging: maps and Tracks in the Human Brain**, B. Wandell, Stanford University

11:00 am: **Learning where to look**, Mary Hayhoe, University of Rochester

Lunch Break 12:00 to 1:30 pm

SESSION 2

Conv. Ctr. Room A3 Mon. 1:30 to 3:30 pm

Mechanisms of Luminance, Color, and Temporal Sensitivity

1:30 pm: **Local luminance effect on spatial summation in the foveal vision and its implication on image artifact classification**, C. Chen, S. Y. Lin, H. G. Han, National Taiwan Univ. (Taiwan) [6057-01]

1:50 pm: **Evaluating contrast sensitivity**, S. Kitagura, L. W. MacDonald, London College of Communication (United Kingdom) [6057-02]

2:10 pm: **Spatio-velocity CSF as a function of retinal velocity using unstabilized stimuli**, J. L. Laird, M. R. Rosen, J. B. Pelz, E. D. Montag, Rochester Institute of Technology; S. J. Daly, Sharp Labs. of America, Inc. [6057-03]

2:30 pm: **A basis for cones**, B. V. Funt, W. Xiong, Simon Fraser Univ. (Canada) [6057-04]

2:50 pm: **High-dynamic range scene compression in humans**, J. J. McCann, McCann Imaging [6057-47]

3:10 pm: **Computational model of lightness perception in HDR imaging**, G. Krawczyk, K. Myszkowski, H. Seidel, Max-Planck-Institut für Informatik (Germany) [6057-05]

Coffee Break 3:30 to 4:00 pm

SESSION 3

Conv. Ctr. Room A3 Mon. 4:00 to 6:00 pm

Eye Movements, Visual Search, and Attention: A Tribute to Larry Stark

4:00 pm: **Larry Stark and scan path**, S. R. Ellis, NASA Ames Research Ctr. [6057-46]

4:20 pm: **A new metrics for definition of gaze area from the geometrical structures of picture composition**, M. Yamazaki, M. Kameda, Iwate Prefectural Univ. (Japan) [6057-06]

4:40 pm: **Target salience and visual search on novel and familiar backgrounds**, K. McDermott, Univ. of Nevada/Reno; J. Mulligan, NASA Ames Research Ctr.; G. Bebis, M. Webster, Univ. of Nevada/Reno [6057-43]

HVEI Banquet 7:30 to 10:30 pm

The annual Human Vision and Electronic Imaging Banquet will be held Monday evening, 16 January, 7:30 to 10:30 pm. The banquet will take place in a local restaurant or wine cellar. For tickets and more information, please visit the Electronic Imaging Registration Desk.

Banquet Speaker: **Jack Tumblin**, Northwestern Univ.

Rethinking Photography: Digital Devices to Capture Appearance

Conference 6057 • Conv. Ctr. Room A3

Tuesday 17 January

Plenary Speaker Tues. 8:30 to 9:15 am

Marriott Ballroom 1-6

Image Processing: Interconnections

Thomas S. Huang, Beckman Institute for Advanced Science and Technology, Univ. of Illinois at Urbana-Champaign

See p. 7 for details.

SESSION 4

Conv. Ctr. Room A3 Tues. 9:30 am to 12:00 pm

Perceptual Image Quality and Applications

- 9:30 am: **Effects of spatial correlations and global precedence on the visual fidelity of distorted images**, D. M. Chandler, K. H. S. Lim, S. S. Hemami, Cornell Univ. [6057-07]
- 9:50 am: **Pseudo no reference image quality metric using perceptual data hiding**, A. Ninassi, P. Le Callet, F. Atrousseau, Univ. de Nantes (France) [6057-08]
- 10:10 am: **Attention-based color correction**, F. W. M. Stentiford, Univ. College London (United Kingdom) [6057-09]
- Coffee Break 10:30 to 11:00 am
- 11:00 am: **Contrast enhancement of medical images using multiscale decomposition**, M. A. Trifas, J. M. Tyler, O. S. Pinykh, Louisiana State Univ. [6057-10]
- 11:20 am: **Human visual alpha stable models for digital halftoning**, A. J. González, J. Bacca Rodríguez, G. R. Arce, Univ. of Delaware; D. L. Lau, Univ. of Kentucky [6057-11]
- 11:40 am: **Study of asthenopia caused by the viewing of stereoscopic images**, H. Hagura, Tokyo Institute of Technology (Japan) [6057-12]
- Lunch Break 12:00 to 1:30 pm

SESSION 5

Conv. Ctr. Room A3 Tues. 1:30 to 2:50 pm

Visually Tuned Algorithms for the Design and Analysis of Flat-Panel Displays

- 1:30 pm: **Perceptual image quality improvement for large screen displays**, F. Lebowsky, Y. Huang, H. Wang, STMicroelectronics (France) [6057-13]
- 1:50 pm: **LCD motion-blur analysis, perception, and reduction using synchronized backlight flashing**, X. Feng, Sharp Labs. of America, Inc. [6057-14]
- 2:10 pm: **Human vision-based algorithm to hide defective pixels in LCDs**, T. R. Kimpe, S. Coulier, Barco N.V. (Belgium) [6057-15]
- 2:30 pm: **Using optimal rendering to visually mask defective subpixels**, D. S. Messing, L. J. Kerofsky, Sharp Labs. of America, Inc. [6057-16]
- Coffee Break 2:50 to 3:20 pm

SESSION 6

Conv. Ctr. Room A3 Tues. 3:20 to 5:40 pm

Perceptual Issues in Video Quality

- 3:20 pm: **Perceptual study of the impact of varying frame rate on motion imagery interpretability quality**, C. P. Fenimore, National Institute of Standards and Technology; J. M. Irvine, Science Applications International Corp.; D. Cannon, National Geospatial-Intelligence Agency; J. W. Roberts, I. Aviles, National Institute of Standards and Technology; S. A. Israel, Science Applications International Corp.; M. Brennan, The Boeing Co.; L. Simon, J. R. Miller, D. S. Haverkamp, Science Applications International Corp.; P. F. Tighe, M. Gross, Booz Allen Hamilton Inc. [6057-17]
- 3:40 pm: **Color preference and perceived color naturalness of digital videos**, C. C. Koh, J. M. Foley, S. K. Mitra, Univ. of California/Santa Barbara [6057-18]
- 4:00 pm: **Stabilizing viewing distances in subjective assessments of mobile video**, M. D. Brotherton, British Telecommunications plc (United Kingdom); K. Brunnström, Acreo AB (Sweden); D. Hands, British Telecommunications plc (United Kingdom) [6057-19]
- 4:20 pm: **Predicting subjective video quality from separated spatial and temporal assessment**, R. R. Pastrana-Vidal, J. Gicquel, J. Blin, France Telecom R&D (France); H. Cherifi, Univ. de Bourgogne (France) [6057-20]
- 4:40 pm: **Handling of annoying variations of performances in video algorithm optimization**, M. M. Nicolas, STMicroelectronics (France) [6057-21]
- 5:00 pm: **Structural similarity quality metrics in a coding context: exploring the space of realistic distortions**, A. Brooks, T. N. Pappas, Northwestern Univ. [6057-22]
- 5:20 pm: **Lossy compression of high dynamic range images and video**, R. Mantiuk, K. Myszkowski, H. Seidel, Max-Planck-Institut für Informatik (Germany) [6057-23]

✓ **Posters and Demonstrations-Tuesday**

Demonstrations 5:30 to 8:30 pm

A symposium-wide demonstration session will be open to attendees 5:30 to 8:30 pm Tuesday evening in Conv. Ctr. Exhibit Hall 1. Demonstrators will provide interactive, hands-on demonstrations of a wide-range of products related to Electronic Imaging.

Posters 5:30 to 7:00 pm

Posters will be placed on display after 10:00 am in Exhibit Hall 1. A poster session, with authors present at their posters, will be held Tuesday evening, 5:30 to 7:00 pm.

- ✓ **Psychophysical measurement for perceptual image brightness enhancement based on image classification**, I. Kim, W. Choe, S. Lee, SAMSUNG Advanced Institute of Technology (South Korea) . [6057-34]
- ✓ **Visual deficiency and image recognition: an image semantic cartography related to visual performance**, A. Scherlen, J. Da Rugna, Univ. Jean Monnet Saint-Etienne (France) [6057-35]
- ✓ **Simple color conversion method to perceptible images for color vision deficiencies**, M. Meguro, C. Takahashi, T. Koga, Yamagata Univ. (Japan) [6057-36]
- ✓ **Toward a taxonomy of textures for image retrieval**, J. S. Payne, Buckinghamshire Chilterns Univ. College (United Kingdom); T. J. Stonham, Brunel Univ. (United Kingdom) [6057-38]

Conference 6057 • Conv. Ctr. Room A3

- ✓ **Using words as lexical basis functions for automatically indexing face images in a manner that correlates with human perception of similarity**, M. Phielipp, J. A. Black, Jr., S. Panchanathan, Arizona State Univ.[6057-39]
- ✓ **Subjective video quality evaluation for multimedia applications**, Q. Huynh-Thu, Psytechnics Ltd. (United Kingdom); M. Ghanbari, Univ. of Essex (United Kingdom); D. Hands, M. D. Brotherton, British Telecommunications plc (United Kingdom)[6057-40]
- ✓ **Texture segmentation using adaptive Gabor filters based on HVS**, S. Bi, D. Liang, Dalian Maritime Univ. (China)[6057-41]
- ✓ **Image stability analysis on the human retina**, M. I. Baritz, Univ. Transilvania din Brasov (Romania)[6057-42]

Wednesday 18 January

Plenary Speaker Wed. 8:30 to 9:15 am
Marriott Ballroom 1-6
Computational Imaging Methods for Functional Brain Mapping and Molecular Imaging
Richard Leahy, Univ. of Southern California
See p. 7 for details.

SESSION 7

Conv. Ctr. Room A3 Wed. 9:30 am to 12:00 pm

Perceptual Approaches to Image Analysis

- 9:30 am: **A closer look at texture metrics**, H. H. Shenav, V. Interrante, Univ. of Minnesota[6057-24]
- 9:50 am: **M-HinTS: mimicking humans in texture sorting**, E. L. van den Broek, Vrije Univ. Amsterdam (Netherlands); T. Kok, T. E. Schouten, Radboud Univ. Nijmegen (Netherlands); E. M. van Rikxoort, Univ. Medisch Ctr. Utrecht (Netherlands)[6057-25]
- 10:10 am: **Inference and segmentation in cortical processing**, Y. Liu, G. A. Cecchi, A. R. Rao, J. Kozloski, C. Peck, IBM Thomas J. Watson Research Ctr.[6057-26]
- Coffee Break 10:30 to 11:00 am
- 11:00 am: **Subjective segmentation evaluation methods: a survey**, E. Drelie Gelasca, T. Ebrahimi, École Polytechnique Fédérale de Lausanne (Switzerland)[6057-27]
- 11:20 am: **Perceptually based techniques for semantic image classification and retrieval**, D. Depalov, T. N. Pappas, Northwestern Univ.[6057-28]
- 11:40 am: **Is Wöflin's system for characterizing art possible to validate by methods used in cognitive-based image-retrieval (CBIR)?**, G. A. M. Derefeldt, S. Nyberg, J. Alfredson, H. U. Allberg, Swedish Defence Research Agency (Sweden)[6057-29]
- Lunch/Exhibition Break 12:00 to 1:40 pm

SESSION 8

Conv. Ctr. Room A3 Wed. 1:40 to 2:40 pm

Detection, Recognition, and Navigation in Complex Environments

- 1:40 pm: **Symbol discriminability models for improved flight displays**, A. J. Ahumada, Jr., M. Trujillo San-Martin, J. Gille, NASA Ames Research Ctr.[6057-30]
- 2:00 pm: **Is haptic watermarking worth it?**, M. Barni, D. Prattichizzo, G. Menegaz, A. Formaglio, M. Franzini, Univ. degli Studi di Siena (Italy); H. Z. Tan, Purdue Univ.[6057-32]
- 2:20 pm: **Display conditions that influence wayfinding in virtual environments**, R. A. Browse, D. W. S. Gray, Queen's Univ. (Canada)[6057-33]

Natural Image Statistics

Conv. Ctr. Room A3 Wed. 2:40 to 4:30 pm

Conference 6058 • Conv. Ctr. Room A2

Tuesday-Thursday 17-19 January 2006 • Proceedings of SPIE Vol. 6058

Color Imaging XI: Processing, Hardcopy, and Applications

Conference Chairs: **Reiner Eschbach**, Xerox Corp.; **Gabriel G. Marcu**, Apple Computer, Inc.

Program Committee: **A. Ufuk Agar**, Garanti Technology (Turkey); **Jan P. Allebach**, Purdue Univ.; **Jan Bares**, NexPress Solutions, LLC; **Phil J. Green**, London College of Communication (United Kingdom); **Roger David Hersch**, École Polytechnique Fédérale de Lausanne (Switzerland); **Patrick G. Herzog**, GretagMachbeth (Germany); **Choon-Woo Kim**, Inha Univ. (South Korea); **Michael A. Kriss**, Consultant; **Shaun T. Love**, Lexmark International, Inc.; **Alessandro Rizzi**, Univ. Degli Studi di Milano (Italy); **Shoji Tominaga**, Osaka Electro-Communication Univ. (Japan); **Chris Tuijn**, Agfa-Gevaert NV (Belgium)

Tuesday 17 January

Plenary Speaker **Tues. 8:30 to 9:15 am**

Marriott Ballroom 1-6

Image Processing: Interconnections

Thomas S. Huang, Beckman Institute for Advanced Science and Technology, Univ. of Illinois at Urbana-Champaign

See p. 7 for details.

SESSION 1

Conv. Ctr. Room A2 **Tues. 3:30 to 6:00 pm**

Color and Color Transforms

Chair: Reiner Eschbach, Xerox Corp.

3:30 pm: **Ideal illuminants for rod/L-cone color**, J. J. McCann, McCann Imaging [6058-01]

4:00 pm: **Accuracy of color transforms**, P. J. Green, London College of Communication (United Kingdom) [6058-02]

4:20 pm: **Color image dequantization by constrained diffusion**, D. Keyzers, T. M. Breuel, DFKI GmbH (Germany) and Univ. of Kaiserslautern (Germany) [6058-03]

4:40 pm: **Spring-primary mapping: a fast color mapping method for primary adjustment and gamut mapping**, H. Zeng, Hewlett-Packard Co. [6058-04]

5:00 pm: **A framework for image-dependent gamut mapping**, J. Giesen, E. Schuberth, ETH Zürich (Switzerland); K. Simon, EMPA (Switzerland); D. Zeiter, ETH Zürich (Switzerland); P. Zolliker, EMPA (Switzerland) . [6058-05]

5:20 pm: **Perceptual gamut mapping algorithm development based upon image quality and preference factors**, B. Kang, M. Cho, H. Choh, C. Kim, SAMSUNG Advanced Institute of Technology (South Korea) [6058-06]

5:40 pm: **Gamut estimation using 2D surface splines**, M. Q. Shaw, Hewlett-Packard Co. [6058-07]

✓ Posters and Demonstrations-Tuesday

Demonstrations **5:30 to 8:30 pm**

A symposium-wide demonstration session will be open to attendees 5:30 to 8:30 pm Tuesday evening in Conv. Ctr. Exhibit Hall 1. Demonstrators will provide interactive, hands-on demonstrations of a wide-range of products related to Electronic Imaging.

Posters **5:30 to 7:00 pm**

Posters will be placed on display after 10:00 am in Exhibit Hall 1. A poster session, with authors present at their posters, will be held Tuesday evening, 5:30 to 7:00 pm.

✓ **High-resolution image viewing on multiprojector distributed parallel rendering display wall**, J. Meng, H. Lin, J. Shi, Zhejiang Univ. (China) [6058-40]

✓ **The application of wavelet transforms and mathematics morphology on the processing of infrared satellite cloud image**, J. Xue, Z. Liu, P. Wang, Tianjin Univ. (China) [6058-41]

✓ **Simulation and parameter optimizing of multielectrode capacitive transducers based on finite element method**, D. Chen, Harbin Univ. of Science and Technology (China) [6058-42]

✓ **Digital watermarking of color image**, S. C. Chao, Ta Hwa Institute of Technology (Taiwan); H. M. Huang, Tung Nan Institute of Technology (Taiwan); C. Y. Chen, Institute of Nuclear Energy Research (Taiwan) [6058-43]

✓ **Subjective assessment of printed color image quality as saturation of the primary colors RGB decreases**, W. Song, H. Seki, Naltec Inc. (Japan); G. Ohashi, Y. Shimodaira, Shizuoka Univ. (Japan) . . . [6058-45]

Wednesday 18 January

Plenary Speaker **Wed. 8:30 to 9:15 am**

Marriott Ballroom 1-6

Computational Imaging Methods for Functional Brain Mapping and Molecular Imaging

Richard Leahy, Univ. of Southern California

See p. 7 for details.

SESSION 2

Conv. Ctr. Room A2 **Wed. 9:30 to 10:20 am**

Color Adjustment

Chair: Phil J. Green, London College of Communication (United Kingdom)

9:30 am: **Uncalibrated color (Invited Paper)**, N. Moroney, Hewlett-Packard Co. [6058-08]

10:00 am: **Geometrical methods for lightness adjustment in YCC color spaces**, R. Samadani, G. Li, Hewlett-Packard Labs. [6058-09]

Coffee Break 10:20 to 10:50 am

Conference 6058 • Conv. Ctr. Room A2

SESSION 3

Conv. Ctr. Room A2 Wed. 10:50 am to 12:10 pm

Digital Photography and Applications

Chair: Michael A. Kriss, Consultant

- 10:50 am: **Measuring gloss by digital photography**, P. Kumar, L. W. MacDonald, London College of Communication (United Kingdom) [6058-10]
- 11:10 am: **Ubiquitous image processing: a novel image-enhancement facility for consumers**, R. Shaw, P. Johnson, White Rose Digital [6058-11]
- 11:30 am: **Color constancy on Japanese animation**, Y. G. Ichihara, Hosen-Gakuen College (Japan) [6058-12]
- 11:50 am: **Convincing non-printers to become future customers**, R. Fageth, W. Schmidt-Sacht, CeWe Color AG & Co. OHG (Germany) [6058-13]
- Lunch/Exhibition Break 12:10 to 1:30 pm

SESSION 4

Conv. Ctr. Room A2 Wed. 1:30 to 3:00 pm

Displays I

Chair: Choon-Woo Kim, Inha Univ. (South Korea)

- 1:30 pm: **DTV color and image processing: past, present, and future (Invited Paper)**, C. Kim, SAMSUNG Advanced Institute of Technology (South Korea) [6058-14]
- 2:00 pm: **Subpixel rendering method for color error minimization on subpixel structured display**, W. Choe, S. Lee, C. Kim, SAMSUNG Advanced Institute of Technology (South Korea) [6058-15]
- 2:20 pm: **Compensation method for color defects in PDP due to different time responses of phosphors**, H. Oh, H. Lee, D. Park, S. Kim, C. Kim, SAMSUNG Advanced Institute of Technology (South Korea) [6058-16]
- 2:40 pm: **Six-primary-color LCD monitor using six-color LEDs with an accurate calibration system**, H. Sugiura, H. Kaneko, S. Kagawa, J. Someya, H. Tanizoe, Mitsubishi Electric Corp. (Japan) [6058-17]
- Coffee Break 3:00 to 3:30 pm

SESSION 5

Conv. Ctr. Room A2 Wed. 3:30 to 5:30 pm

Displays II

Chair: Gabriel G. Marcu, Apple Computer, Inc.

- 3:30 pm: **A color control method for image output with projection displays**, S. Tominaga, K. Kumamoto, Osaka Electro-Communication Univ. (Japan) [6058-18]
- 3:50 pm: **Illuminant-adaptive color reproduction for a mobile display**, J. M. Kim, K. Park, M. Lee, Y. Cho, Y. Ha, Kyungpook National Univ. (South Korea) [6058-19]
- 4:10 pm: **Skin color reproduction algorithm for portrait images shown on the mobile display**, Y. Kwak, S. Lee, D. Park, C. Kim, SAMSUNG Advanced Institute of Technology (South Korea) [6058-20]
- 4:30 pm: **Estimating displays' color fidelity based on classified image statistics**, P. Sun, C. Lee, Shih Hsin Univ. (Taiwan) [6058-21]
- 4:50 pm: **End-user display calibration via support vector regression**, B. Bastani, Hewlett-Packard Co.; B. V. Funt, W. Xiong, Simon Fraser Univ. (Canada) [6058-22]
- 5:10 pm: **The calibration accuracy of display white point by visual calibrator under various illuminations**, T. Sugiyama, Y. Kudo, Dai Nippon Printing Co., Ltd. (Japan) [6058-23]

Thursday 19 January

SESSION 6

Conv. Ctr. Room A2 Thurs. 8:40 to 10:00 am

Printing

Chair: A. Ufuk Agar, Garanti Technology (Turkey)

- 8:40 am: **Black extraction method using gamut boundary descriptors**, M. Cho, B. Kang, H. Choh, SAMSUNG Advanced Institute of Technology (South Korea) [6058-24]
- 9:00 am: **Colorimetric characterization based on color correlation in CMYKGO printer**, I. Jang, C. Son, T. Park, K. Ko, Y. Ha, Kyungpook National Univ. (South Korea) [6058-25]
- 9:20 am: **Hardcopy global color correction**, Y. Bang, Y. Kim, H. Choh, Samsung Advanced Institute of Technology (South Korea) [6058-26]
- 9:40 am: **Efficient document rendering with enhanced run length encoding**, G. Feng, Ricoh Innovations, Inc.; C. A. Bouman, Purdue Univ. [6058-28]
- Coffee Break 10:00 to 10:30 am

SESSION 7

Conv. Ctr. Room A2 Thurs. 10:30 to 11:50 am

Halftoning I

Chair: Jan P. Allebach, Purdue Univ.

- 10:30 am: **Model-based clustered-dot screening**, S. H. Kim, SAMSUNG Electronics Co., Ltd. (South Korea) [6058-29]
- 10:50 am: **AM-FM hybrid color screen design to reduce brightness variation**, B. M. Kang, B. T. Ryu, C. Kim, Inha Univ. (South Korea); S. H. Kim, SAMSUNG Electronics Co., Ltd. (South Korea) [6058-30]
- 11:10 am: **Frequency domain design of cluster dot screens**, M. Fischer, D. Shaked, Hewlett-Packard Labs. (Israel) [6058-31]
- 11:30 am: **A spatial domain optimization method to generate plan-dependent masks**, Y. Wu, Hewlett-Packard Co. [6058-32]
- Lunch Break 11:50 am to 1:30 pm

SESSION 8

Conv. Ctr. Room A2 Thurs. 1:30 to 3:30 pm

Halftoning II

Chair: Reiner Eschbach, Xerox Corp.

- 1:30 pm: **Using errors in halftoning to increase reproduction accuracy**, S. Herron, Global Graphics Software Inc. [6058-33]
- 1:50 pm: **Analysis of misregistration-induced color shifts in the superposition of periodic screens**, B. Oztan, G. Sharma, Univ. of Rochester; R. P. Loce, Xerox Corp. [6058-35]
- 2:10 pm: **Analysis of color error diffusion with vector error filters**, Z. Z. Fan, Xerox Corp. [6058-36]
- 2:30 pm: **New halftoning method combining the best of masking and error diffusion algorithms**, F. Cittadini, Océ Print Logic Technologies (France) and Univ. Pierre et Marie Curie (France); J. Pervillé, S. Berche, Océ Print Logic Technologies (France); M. Ben Chouikha, G. Alquié, Univ. Pierre et Marie Curie (France) [6058-37]
- 2:50 pm: **Graph order dither**, A. Hausner, Univ. of New Hampshire [6058-38]
- 3:10 pm: **Optimal halftoning over hexagonal grids**, J. Bacca Rodriguez, A. J. Gonzalez Lozano, G. R. Arce, Univ. of Delaware; D. L. Lau, Univ. of Kentucky [6058-39]

Conference 6059 • Marriott San Carlos Room

Tuesday-Thursday 17-19 January 2006 • Proceedings of SPIE Vol. 6059

Image Quality and System Performance III

Conference Chairs: **Luke C. Cui**, Lexmark International, Inc.; **Yoichi Miyake**, Chiba Univ. (Japan)

Program Committee: **Peter D. Burns**, Eastman Kodak Co.; **Mark D. Fairchild**, Rochester Institute of Technology; **Susan Farnand**, Eastman Kodak Co.; **Frans Gaykema**, OCE Technologies BV (Netherlands); **Dirk W. Hertel**, Polaroid Corp.; **Robin B. Jenkin**, Cranfield Univ. (United Kingdom); **Nathan Moroney**, Hewlett-Packard Co.; **Rene Rasmussen**, Xerox Corp.; **Eric K. Zeise**, NexPress Solutions, Inc.

Tuesday 17 January

<p>Plenary Speaker Tues. 8:30 to 9:15 am <i>Marriott Ballroom 1-6</i> Image Processing: Interconnections Thomas S. Huang, Beckman Institute for Advanced Science and Technology, Univ. of Illinois at Urbana-Champaign <i>See p. 7 for details.</i></p>
--

✓ Posters and Demonstrations-Tuesday

Demonstrations 5:30 to 8:30 pm

A symposium-wide demonstration session will be open to attendees 5:30 to 8:30 pm Tuesday evening in Conv. Ctr. Exhibit Hall 1. Demonstrators will provide interactive, hands-on demonstrations of a wide-range of products related to Electronic Imaging.

Posters. 5:30 to 7:00 pm

Posters will be placed on display after 10:00 am in Exhibit Hall 1. A poster session, with authors present at their posters, will be held Tuesday evening, 5:30 to 7:00 pm.

- ✓ **Image quality assessment based on textual structure and noise normalization**, C. Zhang, Z. Qiu, Beijing Jiaotong Univ. (China)[6059-36]
- ✓ **Quality models for audiovisual streaming**, T. C. Thang, Y. S. Kim, C. S. Kim, Y. M. Ro, Information and Communications Univ. (South Korea) [6059-37]
- ✓ **Research on the analysis and measurement of MTF of staring imaging system**, D. Lu, Q. Chen, G. Gu, Nanjing Univ. of Science & Technology (China) [6059-38]
- ✓ **Quantification method of the color break-up phenomena: evaluation of next-generation color wheels for field sequential color displays**, J. Thollot, K. Sarayeddine, Thomson R&D France (France); A. Trémeau, Univ. Jean Monnet Saint-Etienne (France) [6059-39]
- ✓ **No-reference jerkiness evaluation method for multimedia communications**, M. Carli, D. Guida, A. Neri, Univ. degli Studi di Roma Tre (Italy) [6059-40]

Wednesday 18 January

<p>Plenary Speaker Wed. 8:30 to 9:15 am <i>Marriott Ballroom 1-6</i> Computational Imaging Methods for Functional Brain Mapping and Molecular Imaging Richard Leahy, Univ. of Southern California <i>See p. 7 for details.</i></p>

SESSION 1

Marriott San Carlos Room Wed. 9:30 to 10:10 am

Image Quality Understanding

Chair: Luke C. Cui, Lexmark International, Inc.

- 9:30 am: **Fundamental questions related to print quality**, P. J. Mangin, M. Dubé, Univ. du Québec à Trois-Rivières (Canada) [6059-01]
- 9:50 am: **What do users really perceive: probing the subjective image quality**, G. S. Nyman, J. Radun, T. Leisti, Univ. of Helsinki (Finland); J. Oja, H. J. Ojanen, J. Olives, T. Vuori, Nokia Research Ctr. (Finland); J. P. Häkkinen, Univ. of Helsinki (Finland) and Nokia Research Ctr. (Finland) [6059-02]
- Coffee Break 10:10 to 10:40 am

SESSION 2

Marriott San Carlos Room ... Wed. 10:40 am to 12:00 pm

Perceptual Attributes and Psychometrics

Chair: Nathan Moroney, Hewlett-Packard Co.

- 10:40 am: **The effect of image sharpness on quantitative eye-movement data and on image quality evaluation while viewing natural images**, T. Vuori, M. Olkkonen, Nokia Corp. (Finland) [6059-03]
- 11:00 am: **Assessing the enhancement of image sharpness**, S. Bouzit, Univ. of St. Andrews (United Kingdom); L. W. MacDonald, London College of Communication (United Kingdom) [6059-04]
- 11:20 am: **Reference-free quality metric using a region-based attention model for JPEG2000 compressed images**, R. Barland, A. Saadane, Univ. de Nantes (France) [6059-05]
- 11:40 am: **Comparison of various subjective video quality assessment methods**, C. Lee, H. Choi, E. Lee, S. Lee, J. Choe, Yonsei Univ. (South Korea) [6059-06]
- Lunch/Exhibition Break 12:00 to 1:20 pm

Conference 6059 • Marriott San Carlos Room

SESSION 3

Marriott San Carlos Room Wed. 1:20 to 2:20 pm

Perceptual Image Quality Modeling

Chair: Susan Farnand, Eastman Kodak Co.

- 1:20 pm: **Selecting significant colors from a complex image for image quality modeling**, K. J. Leeming, P. J. Green, London College of Communication (United Kingdom) [6059-07]
- 1:40 pm: **Comparison of three full-reference color image quality measures**, E. GirshTel, V. Slobodyan, J. S. Weissman, A. M. Eskicioglu, The City Univ. of New York [6059-08]
- 2:00 pm: **Influence of ambient illumination on adapted and optimal white point**, I. Vogels, J. Berentsen, Philips Research Labs. (Netherlands) [6059-09]
- Session Break 2:20 to 2:30 pm

SESSION 4

Marriott San Carlos Room Wed. 2:30 to 3:30 pm

Objective Attributes Characterization I

Chair: Rene S. Rasmussen, Xerox Corp.

- 2:30 pm: **Characterization of digital image noise properties based on RAW data**, H. H. Hytti, Tampereen Teknillinen Yliopisto (Finland) [6059-10]
- 3:00 pm: **An evaluation of sharpness in different image displays used for medical imaging**, M. Ukishima, T. Nakaguchi, Chiba Univ. (Japan); K. Kato, Canon Inc. (Japan); Y. Fukuchi, Chiba Univ. Hospital (Japan); N. Tsumura, Chiba Univ. (Japan); K. Matsumoto, Canon, Inc.; N. Yanagawa, H. Morita, Chiba Univ. Hospital (Japan); Y. Miyake, Chiba Univ. (Japan) [6059-12]
- Coffee Break 3:30 to 4:00 pm

SESSION 5

Marriott San Carlos Room Wed. 4:00 to 5:20 pm

Objective Attributes Characterization II

Chair: Peter D. Burns, Eastman Kodak Co.

- 4:00 pm: **Characterization of printer MTF**, W. Jang, Hewlett-Packard Co.; J. P. Allebach, Purdue Univ. [6059-13]
- 4:20 pm: **PSF estimation by gradient descent fit to the ESF**, E. H. Barney Smith, Boise State Univ. [6059-14]
- 4:40 pm: **Printer banding estimation using the generalized spectrum**, N. A. Rawashdeh, I. Shin, K. D. Donohue, Univ. of Kentucky; S. T. Love, Lexmark International, Inc. [6059-15]
- 5:00 pm: **Scanner-based macroscopic color variation estimation**, C. Kuo, L. Di, E. K. Zeise, NexPress Solutions, Inc. [6059-16]

Thursday 19 January

SESSION 6

Marriott San Carlos Room Thurs. 8:20 to 10:00 am

Standardization I: Progress

Chair: Eric K. Zeise, NexPress Solutions, Inc.

- 8:20 am: **Viewing conditions, colorimetric measurements, and profile making: the conundrum of standards vs. practical realities**, D. Q. McDowell, Standards Consultant [6059-17]
- 8:40 am: **Progress in digital color workflow understanding in the ICC workflow WG**, A. L. McCarthy, Lexmark International, Inc. and International Color Consortium [6059-18]
- 9:00 am: **Recent progress in the development of ISO 19751**, S. Farnand, Eastman Kodak Co.; E. N. Dalal, Xerox Corp.; Y. S. Ng, NexPress Solutions, Inc. [6059-19]

- 9:40 am: **ISO 19751 macro-uniformity**, R. S. Rasmussen, Xerox Corp.; K. D. Donohue, Univ. of Kentucky; Y. S. Ng, NexPress Solutions, Inc.; W. C. Kress, Toshiba America DSE; S. Zoltner, Xerox Corp.; F. Gaykema, OCE Technologies BV (Netherlands) [6059-20]
- Coffee Break 10:00 to 10:30 am

SESSION 7

Marriott San Carlos Room Thurs. 10:30 to 11:30 am

Standardization II: Breakthroughs

Chair: Robin B. Jenkin, Cranfield Univ. (United Kingdom)

- 10:30 am: **Edge-raggedness evaluation using slanted-edge analysis**, P. D. Burns, Eastman Kodak Co. [6059-21]
- 11:00 am: **Statistical interpretation of ISO TC42 dynamic range: risky business**, D. R. Williams, P. D. Burns, Eastman Kodak Co. [6059-22]
- Lunch Break 11:30 am to 1:10 pm

SESSION 8

Marriott San Carlos Room Thurs. 1:10 to 2:10 pm

System Image Quality Characterization and Modeling I

Chair: Dirk W. Hertel, Consultant

- 1:10 pm: **The influence of statistical variations on image quality**, B. O. Hultgren, D. W. Hertel, Consultant; J. Bullitt, Polaroid Corp. [6059-25]
- 1:30 pm: **The use of a virtual printer model for the simulation of imaging systems**, B. O. Hultgren, Consultant [6059-26]
- 1:50 pm: **Improved pen alignment for bidirectional printing**, E. Bernal, J. P. Allebach, Z. Pizlo, Purdue Univ. [6059-27]
- Session Break 2:10 to 2:20 pm

SESSION 9

Marriott San Carlos Room Thurs. 2:20 to 3:30 pm

System Image Quality Characterization and Modeling II

Chair: Frans Gaykema, OCE Technologies BV (Netherlands)

- 2:20 pm: **Further image quality assessment in digital film restoration**, M. Chambah, Univ. de Reims Champagne-Ardenne (France); C. Saint Jean, Univ. de La Rochelle (France); F. Helt, Independent Consultant (France) [6059-28]
- 2:50 pm: **Development of picture quality monitoring system for IPTV service based on the reduced reference framework**, O. Sugimoto, R. Kawada, A. Koike, KDDI R&D Labs. (Japan) [6059-29]
- 3:10 pm: **An image quality evaluation method for DOE-based camera lenses**, S. Lee, Y. Jin, H. Jeong, Samsung Electro-Mechanics Co., Ltd. (South Korea); S. Song, Hanyang Univ. (South Korea) [6059-30]
- Coffee Break 3:30 to 4:00 pm

SESSION 10

Marriott San Carlos Room Thurs. 4:00 to 5:20 pm

Image Defects Characterization and Modeling

Chair: Yoichi Miyake, Chiba Univ. (Japan)

- 4:00 pm: **Visibility and annoyance of LCD defective subpixels of different colors and surrounds at different positions**, H. Ho, J. M. Foley, S. K. Mitra, Univ. of California/Santa Barbara [6059-32]
- 4:20 pm: **Robust detection of defects in imaging arrays**, J. Dudas, C. G. Jung, G. H. Chapman, Simon Fraser Univ. (Canada); Z. Koren, I. Koren, Univ. of Massachusetts/Amherst [6059-33]
- 4:40 pm: **Objective video quality assessment method for freeze distortion based on freeze aggregation**, K. Watanabe, J. Okamoto, T. Kurita, NTT Service Integration Labs. (Japan) [6059-34]
- 5:00 pm: **Film grain synthesis and its applications for re-graining**, P. Schallauer, R. Mörzinger, JOANNEUM RESEARCH GmbH (Austria) [6059-35]

Conference 6060 • Conv. Ctr. Room B1

Monday-Tuesday 16-17 January 2006 • Proceedings of SPIE Vol. 6060

Visualization and Data Analysis 2006

Conference Chairs: **Robert F. Erbacher**, Utah State Univ.; **Jonathan C. Roberts**, Univ. of Kent (United Kingdom); **Matti T. Gröhn**, CSC-Scientific Computing Ltd. (Finland); **Katy Börner**, Indiana Univ.

Cochairs: **Ming C. Hao**, Hewlett-Packard Labs.; **Pak C. Wong**, Pacific Northwest National Lab.

Program Committee: **Uwe Brinkschulte**, Univ. Karlsruhe (Germany); **Philip C. Chen**, Future, Inc.; **L. E. Greenwade**, Idaho National Engineering and Environmental Lab.; **Hans-Georg Pagendarm**, German Aerospace Research Establishment DLR (Germany); **Alex T. Pang**, Univ. of California/Santa Cruz; **Christopher D. Shaw**, Georgia Institute of Technology; **Kalpathi R. Subramanian**, Univ. of North Carolina/Charlotte; **Yinlong Sun**, Purdue Univ.; **J. E. Swan II**, Naval Research Lab.; **Craig M. Wittenbrink**, NVIDIA; **Yingcai Xiao**, Univ. of Akron; **William J. Yurcik**, Univ. of Illinois at Urbana-Champaign

Monday 16 January

SESSION 1

Conv. Ctr. Room B1 Mon. 8:30 to 9:30 am

Flow Visualization

Chair: **Robert F. Erbacher**, Utah State Univ.

- 8:30 am: **Multiscale image based flow visualization**, A. C. Telea, Technische Univ. Eindhoven (Netherlands); R. Strzodka, Research Ctr. Caesar (Germany) [6060-01]
- 8:50 am: **Visualizing oceanic and atmospheric flows with streamline splatting**, Y. Sun, E. Ess, D. Sapirstein, M. Huber, Purdue Univ. [6060-02]
- 9:10 am: **View-dependent multiresolutional flow texture advection**, L. Li, H. Shen, The Ohio State Univ. [6060-03]
- Session Break 9:30 to 9:40 am

SESSION 2

Conv. Ctr. Room B1 Mon. 9:40 to 11:10 am

Volume Visualization

Chair: **Matti T. Gröhn**, Ctr. for Scientific Computing (Finland)

- 9:40 am: **Volumetric depth peeling for medical image display**, D. M. Borland, J. P. Clarke, J. R. Fielding, R. M. Taylor II, The Univ. of North Carolina at Chapel Hill [6060-04]
- Coffee Break 10:00 to 10:30 am
- 10:30 am: **Adaptive border sampling for hardware texture-based volume visualization**, E. C. LaMar, Institute for Scientific Research, Inc. [6060-05]
- 10:50 am: **Ray-casting time-varying volume data sets with frame-to-frame coherence**, D. Tost, S. Grau, Univ. Politècnica de Catalunya (Spain); M. Ferre, Univ. Rovira i Virgili (Spain); A. Puig, Univ. de Barcelona (Spain) [6060-06]
- Session Break 11:10 to 11:20 am

SESSION 3

Conv. Ctr. Room B1 Mon. 11:20 am to 12:00 pm

Visualization Theory

Chair: **Pak C. Wong**, Pacific Northwest National Lab.

- 11:20 am: **Theoretical analysis of uncertainty visualizations**, T. D. Zuk, M. S. T. Carpendale, Univ. of Calgary (Canada) [6060-07]
- 11:40 am: **A visualization framework for design and evaluation**, B. J. Blundell, S. Pettifer, The Univ. of Manchester (United Kingdom); G. Ng, Cerebra, Inc. [6060-08]
- Lunch Break 12:00 to 1:30 pm

SESSION 4

Conv. Ctr. Room B1 Mon. 1:30 to 2:00 pm

Invited Paper I

Chair: **Robert F. Erbacher**, Utah State Univ.

- 1:30 pm: **Visual analytics and the NVAC (Invited Paper, Presentation Only)**, P. C. Wong, Pacific Northwest National Lab. [6060-09]
- Session Break 2:00 to 2:10 pm

SESSION 5

Conv. Ctr. Room B1 Mon. 2:10 to 3:10 pm

Lighting

Chair: **Matti T. Gröhn**, Ctr. for Scientific Computing (Finland)

- 2:10 pm: **Maximum entropy lighting for physical objects**, T. Malzbender, E. Ordentlich, Hewlett-Packard Labs. [6060-10]
- 2:30 pm: **Pre-computed illumination for isosurfaces**, K. M. Beason, Florida State Univ.; J. Grant, Pixar Animation Studios; D. C. Banks, B. Futch, M. Y. Hussaini, Florida State Univ. [6060-11]
- 2:50 pm: **Retro-rendering with vector-valued light: producing local illumination from the transport equation**, D. C. Banks, K. M. Beason, Florida State Univ. [6060-12]
- Coffee Break 3:10 to 3:40 pm

SESSION 6

Conv. Ctr. Room B1 Mon. 3:40 to 4:20 pm

Image Processing

Chair: **Ming C. Hao**, Hewlett-Packard Labs.

- 3:40 pm: **Bit-plane based analysis of integer wavelet coefficients for image compression**, A. F. Abu-Hajar, Digitavid, Inc. [6060-13]
- 4:00 pm: **Two-dimensional reduction PCA: a novel approach for feature extraction, representation, and recognition**, R. M. Mutelo, W. L. Woo, S. S. Dlay, Univ. of Newcastle Upon Tyne (United Kingdom) [6060-14]
- Session Break 4:20 to 4:30 pm

SESSION 7

Conv. Ctr. Room B1 Mon. 4:30 to 5:10 pm

Terrain/GIS Visualization

Chair: **Edward Suvanaphen**, Univ. of Kent (United Kingdom)

- 4:30 pm: **Energetically optimal travel across terrain: visualizations and a new metric of geographic distance with archaeological applications**, B. Wood, Harvard Univ.; Z. Wood, California Polytechnic State Univ. [6060-15]
- 4:50 pm: **Real-time 3D visualization of DEM combined with a robust DCT-based data-hiding method**, A. Martin, Univ. Montpellier II (France); G. Gesquiere, Univ. de Provence (France); W. Puech, Univ. Montpellier II (France); S. Thon, Univ. de Provence (France) [6060-16]
- Session Break 5:10 to 5:20 pm

Conference 6060 • Conv. Ctr. Room B1

SESSION 8

Conv. Ctr. Room B1 Mon. 5:20 to 6:00 pm

Applications

Chair: Katy Börner, Indiana Univ.

- 5:20 pm: **Hierarchical causality explorer: making complementary use of 3D/2D visualizations**, S. Azuma, Ochanomizu Univ. (Japan); I. Fujishiro, Tohoku Univ. (Japan); H. Horii, The Univ. of Tokyo (Japan) [6060-17]
- 5:40 pm: **InvIncements: incremental software to support visual simulation**, D. C. Banks, W. Blanco, Florida State Univ. [6060-18]

Tuesday 17 January

<p>Plenary Speaker Tues. 8:30 to 9:15 am</p> <p><i>Marriott Ballroom 1-6</i></p> <p>Image Processing: Interconnections</p> <p>Thomas S. Huang, Beckman Institute for Advanced Science and Technology, Univ. of Illinois at Urbana-Champaign</p> <p><i>See p. 7 for details.</i></p>
--

SESSION 9

Conv. Ctr. Room B1 Tues. 9:40 to 10:20 am

Interaction Techniques

Chair: Ming C. Hao, Hewlett-Packard Labs.

- 9:40 am: **Plot of plots and selection glass**, H. Chen, SAS Institute Inc. [6060-19]
- 10:00 am: **Navigation techniques for large-scale astronomical exploration**, C. Fu, The Hong Kong Univ. of Science and Technology (Hong Kong China); A. J. Hanson, E. A. Wernert, Indiana Univ. ... [6060-20]
- Coffee Break 10:20 to 10:50 am

SESSION 10

Conv. Ctr. Room B1 Tues. 10:50 to 11:50 am

InfoVis

Chair: Ketan K. Mane, Indiana Univ.

- 10:50 am: **Reducing InfoVis cluttering through non uniform sampling, displacement, and user perception**, E. Bertini, G. Santucci, L. Dell'Aquila, Univ. degli Studi di Roma/La Sapienza (Italy) [6060-21]
- 11:10 am: **Diverse information integration and visualization**, S. L. Havre, A. R. Shah, C. Posse, B. M. Webb-Robertson, Pacific Northwest National Lab. [6060-22]
- 11:30 am: **WordSpace: visual summary of text corpora**, U. Brandes, M. Hofer, J. Lerner, Univ. of Konstanz (Germany) [6060-23]
- Lunch/Exhibition Break 11:50 am to 1:40 pm

SESSION 11

Conv. Ctr. Room B1 Tues. 1:40 to 2:10 pm

Invited Paper II

Chair: Ketan K. Mane, Indiana Univ.

- 1:40 pm: **Information architecture: why design matters (Invited Paper, Presentation Only)**, J. Agutter, Univ. of Utah [6060-24]
- Session Break 2:10 to 2:20 pm

SESSION 12

Conv. Ctr. Room B1 Tues. 2:20 to 3:20 pm

Visualization Techniques I

Chair: Matti T. Gröhn, Ctr. for Scientific Computing (Finland)

- 2:20 pm: **Trees in a treemap: visualizing multiple hierarchies**, M. Burch, S. Diehl, Katholische Univ. Eichstätt (Germany) [6060-25]

- 2:40 pm: **Focus-based filtering + clustering technique for power-law networks with small world phenomenon**, F. Boutin, J. Thièvre, M. Hascoët, Univ. Montpellier II (France) and CNRS (France) [6060-26]
- 3:00 pm: **Enhancing scatterplot matrices for data with ordering or spatial attributes**, Q. Cui, M. O. Ward, E. A. Rundensteiner, Worcester Polytechnic Institute [6060-27]
- Coffee Break 3:20 to 3:50 pm

SESSION 13

Conv. Ctr. Room B1 Tues. 3:50 to 4:30 pm

Visualization Techniques II

Chair: Edward Suvanaphen, Univ. of Kent (United Kingdom)

- 3:50 pm: **Content-based text mapping using multidimensional projections for exploration of document collections**, R. Minghim, F. V. Paulovich, A. de Andrade Lopes, Univ. de São Paulo (Brazil) ... [6060-28]
- 4:10 pm: **Mapping texts through dimensionality reduction and visualization techniques for interactive exploration of document collections**, A. d. A. de Andrade Lopes, R. Minghim, V. Melo, F. V. Paulovich, Univ. de São Paulo (Brazil) [6060-29]
- Session Break 4:30 to 4:40 pm

SESSION 14

Conv. Ctr. Room B1 Tues. 4:40 to 5:20 pm

Bioinformatics

Chair: Robert F. Erbacher, Utah State Univ.

- 4:40 pm: **Visualizing brain rhythms and synchrony**, K. A. Robbins, D. Veljkovic, E. Pilipaviciute, The Univ. of Texas at San Antonio ... [6060-30]
- 5:00 pm: **Automatic feature-based surface mapping for brain cortices**, L. Linsen, Ernst Moritz Arndt Univ. Greifswald (Germany) [6060-31]

✓ Posters and Demonstrations-Tuesday

Demonstrations 5:30 to 8:30 pm

A symposium-wide demonstration session will be open to attendees 5:30 to 8:30 pm Tuesday evening in Conv. Ctr. Exhibit Hall 1. Demonstrators will provide interactive, hands-on demonstrations of a wide-range of products related to Electronic Imaging.

Posters 5:30 to 7:00 pm

Posters will be placed on display after 10:00 am in Exhibit Hall 1. A poster session, with authors present at their posters, will be held Tuesday evening, 5:30 to 7:00 pm.

- ✓ **Blogviz: mapping the dynamics of information diffusion in blogspace**, M. S. Lima, Parsons School of Design [6060-32]
- ✓ **Organizing and visualizing database data using parallel coordinates**, C. G. Presser, Gettysburg College [6060-33]
- ✓ **Visualizing 3D vector fields with splatted streamlines**, E. Ess, Y. Sun, Purdue Univ. [6060-35]
- ✓ **SRS browser: a visual interface to the sequence retrieval system**, K. K. Mane, K. Borner, Indiana Univ. [6060-36]
- ✓ **Tracing parallel vectors**, J. Sukharev, Univ. of California/Santa Cruz [6060-39]
- ✓ **Output-sensitive volume tracking**, L. Jiang, Rutgers Univ. ... [6060-40]
- ✓ **Visualization of force fields in protein structure prediction**, S. N. Crivelli, Lawrence Berkeley National Lab. and California Institute for Quantitative Biomedical Research; C. Crawford, O. Kreylos, B. Hamann, Univ. of California/Davis [6060-41]
- ✓ **Correspondence-based visualization techniques**, M. J. Gerald-Yamasaki, NASA Ames Research Ctr. [6060-42]

Conference 6061 • Conv. Ctr. Room B4

Wednesday-Thursday 18-19 January 2006 • Proceedings of SPIE Vol. 6061

Internet Imaging VII

Conference Chairs: **Simone Santini**, Univ. of California/San Diego; **Raimondo Schettini**, DISCo/Univ. degli Studi di Milano-Bicocca (Italy); **Theo Gevers**, Univ. van Amsterdam (Netherlands)

Program Committee: **Jeffrey E. Boyd**, Univ. of Calgary (Canada); **Alberto Del Bimbo**, Univ. degli Studi di Firenze (Italy); **Jennifer Gille**, Raytheon Co.; **Hagit Z. Hel-Or**, Univ. of Haifa (Israel); **Roger David Hersch**, École Polytechnique Fédérale de Lausanne (Switzerland); **Yasuyo G. Ichihara**, Hosen-Gakuen College (Japan); **Reiner Lenz**, Linköpings Univ. (Sweden); **Clement H. C. Leung**, Victoria Univ. of Technology (Australia); **Yong Rui**, Microsoft Research; **Simon Shim**, San José State Univ.; **Alain Trémeau**, Univ. Jean Monnet (France); **Luc J. Van Gool**, Katholieke Univ. Leuven (Belgium)

Tuesday 17 January

Plenary Speaker **Tues. 8:30 to 9:15 am**
Marriott Ballroom 1-6
Image Processing: Interconnections
Thomas S. Huang, Beckman Institute for Advanced Science and Technology, Univ. of Illinois at Urbana-Champaign
See p. 7 for details.

✓ Posters and Demonstrations-Tuesday

Demonstrations **5:30 to 8:30 pm**

A symposium-wide demonstration session will be open to attendees 5:30 to 8:30 pm Tuesday evening in Conv. Ctr. Exhibit Hall 1. Demonstrators will provide interactive, hands-on demonstrations of a wide-range of products related to Electronic Imaging.

Posters **5:30 to 7:00 pm**

Posters will be placed on display after 10:00 am in Exhibit Hall 1. A poster session, with authors present at their posters, will be held Tuesday evening, 5:30 to 7:00 pm.

- ✓ **Subjective trajectory characterization: acquisition, matching, and retrieval**, M. Y. Zhang, L. Olsen, J. E. Boyd, Univ. of Calgary [6061-30]
- ✓ **Archiving of meaningful scenes for personal TV terminals**, S. H. Jin, J. H. Cho, Y. M. Ro, Information and Communications Univ. (South Korea); J. Kim, Electronics and Telecommunications Research Institute (South Korea) [6061-32]
- ✓ **AVIR: a spoken document retrieval system in e-learning environment**, I. Gagliardi, M. Padula, P. Pagliarulo, Consiglio Nazionale delle Ricerche (Italy) [6061-33]
- ✓ **Internet-based remote counseling to support stress management: preventing interruptions to regular exercise in elderly people**, S. Hashimoto, Univ. of Tsukuba (Japan) and National Institute of Information and Communications Technology (Japan); T. Munakata, Univ. of Tsukuba (Japan); N. Hashimoto, Citizen Watch Co., Ltd. (Japan); J. Okunaka, T. Koga, National Institute of Information and Communications Technology (Japan) [6061-34]
- ✓ **Vertex and face permutation order compression for efficient animation support**, E. Chang, Electronics and Telecommunications Research Institute (South Korea); D. Kim, B. Min, S. Lee, Hanyang Univ. (South Korea); N. Hur, S. Lee, Electronics and Telecommunications Research Institute (South Korea); E. S. Jang, Hanyang Univ. (South Korea) [6061-35]

Wednesday 18 January

Plenary Speaker **Wed. 8:30 to 9:15 am**
Marriott Ballroom 1-6
Computational Imaging Methods for Functional Brain Mapping and Molecular Imaging
Richard Leahy, Univ. of Southern California
See p. 7 for details.

SESSION 1

Conv. Ctr. Room B4 **Wed. 9:30 to 10:20 am**

Special Session: Benchmarking I

9:30 am: **Requirements for benchmarking personal image retrieval systems (Invited Paper)**, J. Bouguet, C. Dulong, I. V. Kozintsev, Intel Corp. [6061-01]
10:00 am: **On usage models of content-based image search, filtering, and annotation**, D. Telleen-Lawton, C. B. Chang, VIMA Technologies, Inc.; E. Y. Chang, Univ. of California/Santa Barbara [6061-02]
Coffee Break 10:20 to 10:50 am

SESSION 2

Conv. Ctr. Room B4 **Wed. 10:50 to 11:50 am**

Special Session: Benchmarking II

10:50 am: **Human factors in automatic image retrieval system design and evaluation**, A. Jaimes, Fuji Xerox Co., Ltd. (Japan) [6061-03]
11:10 am: **Lessons from TRECVID: lexicon design for semantic indexing in media databases**, M. R. Naphade, IBM Thomas J. Watson Research Ctr. [6061-04]
11:30 am: **Benchmarking without ground truth**, S. Santini, Univ. of California/San Diego [6061-21]
Lunch/Exhibition Break 11:30 am to 1:00 pm

SESSION 3

Conv. Ctr. Room B4 **Wed. 1:00 to 2:00 pm**

Special Session: Benchmarking III

1:00 pm: **Using heterogeneous annotation and visual information for the benchmarking of image retrieval system**, H. Müller, Univ. Hospital of Geneva (Switzerland) [6061-06]
1:20 pm: **On benchmarking content-based image retrieval applications**, B. Zhang, Y. Zuo, Tsinghua Univ. (China) [6061-07]
1:40 pm: **TRECVID: the utility of a content-based video retrieval evaluation**, A. G. Hauptmann, Carnegie Mellon Univ. [6061-08]

Conference 6061 • Conv. Ctr. Room B4

SESSION 4

Conv. Ctr. Room B4 Wed. 2:00 to 3:10 pm

Interfaces and Visualization

- 2:00 pm: **A color selection tool ensuring legibility of textual information on web pages (Invited Paper)**, S. Zuffi, Consiglio Nazionale delle Ricerche (Italy); G. B. Beretta, Hewlett-Packard Co.; C. Brambilla, Consultant (Italy)[6061-10]
- 2:30 pm: **A color interface for audio clustering visualization**, S. Zuffi, I. Gagliardi, Consiglio Nazionale delle Ricerche (Italy) [6061-11]
- 2:50 pm: **Interactive internet delivery of scientific visualization vis structured prerendered imagery**, J. Chen, San Francisco State Univ. and Lawrence Berkeley National Lab.; E. W. Bethel, Lawrence Berkeley National Lab.; I. Yoon, San Francisco State Univ. [6061-12]
- Coffee Break 3:10 to 3:40 pm

SESSION 5

Conv. Ctr. Room B4 Wed. 3:40 to 4:20 pm

Ontology and Annotation

- 3:40 pm: **Clustering and semantically filtering web images to create a large-scale image ontology**, S. Zinger, C. Millet, M. Benoit, G. Grefenstette, P. Hède, P. Moëllic, Commissariat à l'Énergie Atomique (France) [6061-13]
- 4:00 pm: **Ontology and image semantics in multimodal imaging: submission and retrieval**, Y. Bei, M. Belmamoune, F. J. Verbeek, Leiden Univ. (Netherlands) [6061-14]

Thursday 19 January

SESSION 6

Conv. Ctr. Room B4 Thurs. 9:00 to 10:00 am

Anthropometrics

- 9:00 am: **Combining color models for skin detection**, F. Aldershoff, T. Gevers, H. M. Stokman, Univ. van Amsterdam (Netherlands) ... [6061-16]
- 9:20 am: **Using context and similarity for face and location identification**, M. Davis, Univ. of California/Berkeley; M. A. Smith, France Telecom R&D (France); J. F. Canny, Univ. of California/Berkeley; F. W. M. Stentiford, Univ. College London (United Kingdom) [6061-17]
- 9:40 am: **Skin segmentation using multiple thresholding**, F. Gasparini, R. Schettini, Univ. degli Studi di Milano-Bicocca (Italy) [6061-18]
- Coffee Break 10:00 to 10:30 am

SESSION 7

Conv. Ctr. Room B4 Thurs. 10:30 am to 12:10 pm

Content Management and Retrieval

- 10:30 am: **Integration of multimedia contents and e-learning resources in a digital library**, M. Pascual, N. Ferran, J. Minguillón Alfonso, Univ. Oberta de Catalunya (Spain) [6061-19]
- 10:50 am: **Selecting the kernel type for a web-based adaptive image retrieval systems (AIRS)**, A. Doloc-Mihu, V. V. Raghavan, Univ. of Louisiana at Lafayette [6061-20]
- 11:10 am: **FaceLab: a tool for performance evaluation of face recognition strategies**, L. Caffisch, Comerson s.r.l. (Italy); A. Colombo, C. Cusano, R. Schettini, F. Tisato, Univ. degli Studi di Milano-Bicocca (Italy) [6061-36]
- 11:30 am: **Medical validation and CBIR of spine x-ray images over the Internet**, S. K. Antani, J. Cheng, J. L. Long, L. R. Long, G. R. Thoma, National Library of Medicine [6061-22]
- 11:50 am: **The integration of cartographic information into a content management system**, M. M. Furnari, C. I. D. Noviello, Consiglio Nazionale delle Ricerche (Italy) [6061-23]
- Lunch Break 12:10 to 1:30 pm

SESSION 8

Conv. Ctr. Room B4 Thurs. 1:30 to 2:10 pm

Video

- 1:30 pm: **Enhanced video display and navigation for networked streaming video and networked video playlists**, S. G. Deshpande, Sharp Labs. of America, Inc. [6061-24]
- 1:50 pm: **3D display technique for moving pictures from web cameras using screen pixel accessing**, T. Hasegawa, T. Namiki, H. Unno, K. Uehira, H. Kasuga, K. Yanaka, Kanagawa Institute of Technology (Japan) [6061-25]

SESSION 9

Conv. Ctr. Room B4 Thurs. 2:10 to 2:50 pm

Vector Displays

- 2:10 pm: **Dynamic conversion between XML-based languages for vector graphics**, A. Di Iorio, F. Vitali, G. Zonta, Univ. degli Studi di Bologna (Italy) [6061-28]
- 2:30 pm: **Bezier curves approximation of triangularized surfaces using SVG**, G. Messina, STMicroelectronics (Italy); E. Ingra, S. Battiato, G. Di Blasi, Univ. di Catania (Italy) [6061-29]

Conference 6062 • Conv. Ctr. Room A2

Monday-Tuesday 16-17 January 2006 • Proceedings of SPIE Vol. 6062

Spectral Imaging: Eighth International Symposium on Multispectral Color Science

Conference Chairs: **Mitchell R. Rosen**, Rochester Institute of Technology; **Francisco H. Imai**, Pixim, Inc.; **Shoji Tominaga**, Osaka Electro-Communication Univ. (Japan)

Program Committee: **Roy S. Berns**, Rochester Institute of Technology; **Jeffrey M. DiCarlo**, Hewlett-Packard Labs.; **Jon Y. Hardeberg**, Gjøvik Univ. College (Norway); **Markku Hauta-Kasari**, Univ. of Joensuu (Finland); **Bernhard Hill**, Univ. Aachen (Germany); **Reiner Lenz**, Linköping Univ. (Sweden); **Yoshitsugu Manabe**, Nara Institute of Science and Technology (Japan); **Yoichi Miyake**, Chiba Univ. (Japan); **Javier Romero**, Univ. de Granada (Spain); **Norimichi Tsumura**, Chiba Univ. (Japan); **Stephen Westland**, Univ. of Derby (United Kingdom)

Monday 16 January

SESSION 1

Conv. Ctr. Room A2 Mon. 9:00 to 10:20 am

Spectral Analysis for Scene Content Identification I

Chair: **Francisco H. Imai**, Rochester Institute of Technology

9:00 am: **Hyperspectral imaging of sulfate evaporite deposits in Western Australia and on Mars (Invited Paper)**, A. J. Brown, Macquarie Univ. (Australia) and Australian Ctr. for Astrobiology (Australia); T. J. Cudahy, Commonwealth Scientific & Industrial Research Organisation (Australia) [6062-01]

9:40 am: **Multispectral imaging determination of pigment concentration profiles in meat**, C. Sáenz, B. Hernández, C. Alberdi, S. Alfonso, M. Berrogui, J. M. Diñeiro, Univ. Publica de Navarra (Spain) [6062-02]

10:00 am: **Visualization of the human face skin moisturizing-ability by spectroscopic imaging using two near-infrared bands**, H. Iwasaki, K. Miyazawa, S. Nakauchi, Toyohashi Univ. of Technology (Japan) [6062-03]

Coffee Break 10:20 to 10:50 am

SESSION 2

Conv. Ctr. Room A2 Mon. 10:50 am to 12:20 pm

Spectral Analysis for Scene Content Identification II

Chair: **Javier Hernandez-Andres**, Univ. de Granada (Spain)

10:50 am: **Spectral estimation of made-up skin color under various conditions (Invited Paper)**, M. Doi, R. Ohtsuki, S. Tominaga, Osaka Electro-Communication Univ. (Japan) [6062-05]

11:20 am: **Image processing techniques for detection of buried objects in infrared images**, A. Ceron-Correa, Univ. Militar Nueva Granada (Colombia); O. L. Lopera, Royal Military Academy (Belgium) and Univ. de Los Andes (Colombia) [6062-04]

11:40 am: **MODIS versus ASTER water classification**, C. Alecu, S. Oancea, National Meteorological Administration (Romania); E. Bryant, Dartmouth College [6062-06]

12:00 pm: **Improving multivariate curve resolution analysis performance when applied to fluorescence hyperspectral biological imaging (Presentation Only)**, H. D. T. Jones, E. Thomas, D. M. Haaland, J. A. Timlin, M. B. Sinclair, Sandia National Labs. [6062-07]

Lunch Break 12:20 to 1:50 pm

SESSION 3

Conv. Ctr. Room A2 Mon. 1:50 to 2:30 pm

Spectral Estimation Methods

Chair: **Masahiro Yamaguchi**, Tokyo Institute of Technology (Japan)

1:50 pm: **Estimating reflectance parameters from saturated spectral images**, S. Li, Y. Manabe, K. Chihara, Nara Institute of Science and Technology (Japan) [6062-08]

2:10 pm: **Influence of the recovery method in the optimum sensors for spectral imaging of skylight**, M. A. Lopez-Alvarez, J. Hernandez-Andres, J. L. Nieves, J. Romero, Univ. de Granada (Spain) [6062-09]

SESSION 4

Conv. Ctr. Room A2 Mon. 2:30 to 4:50 pm

Spectral Acquisition Systems

Chairs: **Javier Romero**, Univ. de Granada (Spain); **Markku Hauta-Kasari**, Joensuu Yliopisto (Finland)

2:30 pm: **Demosaicking methods for multispectral cameras using mosaic focal plane array technology (Invited Paper)**, G. A. Baone, H. Qi, The Univ. of Tennessee [6062-10]

3:00 pm: **Estimation of noise variance of a multispectral image acquisition system**, N. Shimano, Kinki Univ. (Japan) [6062-11]

Coffee Break 3:20 to 3:50 pm

3:50 pm: **Multispectral stand-off imaging with mid-infrared semiconductor lasers**, Y. Wang, Y. Wang, H. Q. Le, Univ. of Houston [6062-12]

4:10 pm: **Designing flat-bed scanning system for spectral and glossiness recording**, T. Takiguchi, S. Abe, T. Makino, N. Tsumura, T. Nakaguchi, Chiba Univ. (Japan); F. Nakaya, H. Ichikawa, Y. Minato, Fuji Xerox Co., Ltd. (Japan); K. Miyata, National Museum of Japanese History (Japan); Y. Miyake, Chiba Univ. (Japan) [6062-13]

4:30 pm: **Color measurements with colorimetric and multispectral imaging systems**, M. de Lasarte, M. Vilaseca, J. Pujol, M. Arjona, Univ. Politècnica de Catalunya (Spain) [6062-15]

Conference 6062 • Conv. Ctr. Room A2

Tuesday 17 January

Plenary Speaker Tues. 8:30 to 9:15 am

Marriott Ballroom 1-6

Image Processing: Interconnections

Thomas S. Huang, Beckman Institute for Advanced Science and Technology, Univ. of Illinois at Urbana-Champaign

See p. 7 for details.

SESSION 5

Conv. Ctr. Room A2 Tues. 9:30 am to 12:00 pm

Spectral Reproduction

Chair: Shoji Tominaga, Osaka Electro-Communication Univ. (Japan)

9:30 am: High-fidelity video and still-image communication based on spectral information: natural vision system and its applications (Invited Paper), M. Yamaguchi, Tokyo Institute of Technology (Japan); H. Haneishi, Chiba Univ. (Japan); H. Fukuda, J. Kishimoto, H. Kanazawa, M. Tsuchida, R. Iwama, National Institute of Information and Communications Technology (Japan); N. Ohshima, Tokyo Institute of Technology (Japan) [6062-16]

10:00 am: Encoding of spectra for multiple observers and multiple illuminants, T. Boosmann, RWTH Aachen (Germany) [6062-17]

Coffee Break 10:20 to 10:50 am

10:50 am: Spectral-based color reproduction for print illuminated by image projector (Invited Paper), K. Ueda, S. Yamamoto, N. Tsumura, T. Nakaguchi, Y. Miyake, Chiba Univ. (Japan) [6062-18]

11:20 am: Spectral-based optimization of screen images for industrial product presentation, L. Härkönen, J. B. Martinkauppi, H. T. Laamanen, M. Hauta-Kasari, Joensuu Yliopisto (Finland); P. Huhtelin, P. Horttanainen, Tulikivi Oyj (Finland) [6062-19]

11:40 am: Spectral gamuts and spectral gamut mapping, M. R. Rosen, Rochester Institute of Technology; M. W. Derhak, Onyx Graphics [6062-20]

Lunch/Exhibition Break 12:00 to 1:30 pm

SESSION 6

Conv. Ctr. Room A2 Tues. 1:30 to 2:20 pm

Art Spectral Imaging

Chair: Norimichi Tsumura, Chiba Univ. (Japan)

1:30 pm: A technique for detecting metameric color areas for investigation of historical materials (Invited Paper), K. Miyata, National Museum of Japanese History (Japan); H. T. Laamanen, T. Jaaskelainen, M. Hauta-Kasari, J. P. Parkkinen, Joensuu Yliopisto (Finland) [6062-21]

2:00 pm: A scanning device for multispectral imaging of paintings, C. Bonifazzi, Univ. degli Studi di Ferrara (Italy); P. Carcagni, A. D. Patria, Istituto Nazionale di Ottica Applicata (Italy); S. Ferriani, ENEA (Italy); R. Fontana, M. Greco, M. G. Mastroianni, M. Materazzi, E. M. Pampaloni, A. Romano, Istituto Nazionale di Ottica Applicata (Italy) [6062-22]

SESSION 7

Conv. Ctr. Room A2 Tues. 2:20 to 3:00 pm

Spectral Video Systems

Chair: Mitchell R. Rosen, Rochester Institute of Technology

2:20 pm: Spectral video intraframe compression and database, J. P. Purmonen, M. Hauta-Kasari, J. Tuomela, Joensuu Yliopisto (Finland); M. Yamaguchi, M. Mitsui, Tokyo Institute of Technology (Japan); H. Fukuda, National Institute of Information and Communications Technology (Japan) [6062-23]

2:40 pm: Real-time, multispectral, color acquisition and display using commodity hardware components, D. L. Lau, A. M. Tan, Univ. of Kentucky [6062-24]

✓ Posters and Demonstrations-Tuesday

Demonstrations 5:30 to 8:30 pm

A symposium-wide demonstration session will be open to attendees 5:30 to 8:30 pm Tuesday evening in Conv. Ctr. Exhibit Hall 1.

Demonstrators will provide interactive, hands-on demonstrations of a wide-range of products related to Electronic Imaging.

Posters 5:30 to 7:00 pm

Posters will be placed on display after 10:00 am in Exhibit Hall 1. A poster session, with authors present at their posters, will be held Tuesday evening, 5:30 to 7:00 pm.

✓ Construction of multichannel camera gamuts, S. Helling, RWTH Aachen (Germany) [6062-25]

✓ Importance of the texture features in a query from spectral image databases, O. Kohonen, M. Hauta-Kasari, Univ. of Joensuu (Finland) [6062-27]

Conference 6063 • Conv. Ctr. Room B3

Monday-Tuesday 16-17 January 2006 • Proceedings of SPIE Vol. 6063

Real-Time Image Processing III

Conference Chairs: **Nasser Kehtarnavaz**, The Univ. of Texas at Dallas; **Phillip A. Laplante**, The Pennsylvania State Univ.

Program Committee: **Mohamed Akil**, École Supérieure d'Ingénieurs en Électronique et Électrotechnique (France); **Matthias F. Carlsohn**, Computer Vision and Image Communication (Germany); **Carlos R. Castro-Pareja**, Univ. of Maryland/Baltimore; **Luciano F. da Fontoura Costa**, Univ. de São Paulo (Brazil); **Philip P. Dang**, STMicroelectronics; **Xavier Desurmont**, Multitel (Belgium); **Edward R. Dougherty**, Texas A&M Univ.; **Sang-Yong Lee**, Texas Instruments Inc.; **Chang-Joon Park**, Electronics and Telecommunications Research Institute (South Korea); **Gregory Pisanich**, NASA Ames Research Ctr.; **Volodymyr I. Ponomaryov**, Instituto Politécnico Nacional (Mexico); **Fatih M. Porikli**, Mitsubishi Electric Research Labs.; **Raghvinder S. Sangwan**, The Pennsylvania State Univ.; **Feng Xiao**, Agilent Technologies

Monday 16 January

SESSION 1

Conv. Ctr. Room B3 Mon. 8:50 to 10:00 am

Medical Applications

Chair: **Nasser Kehtarnavaz**, The Univ. of Texas at Dallas

- 8:30 am: **Fast computation of free-form deformations in 3D images using FPGAs (Invited Paper)**, C. R. Castro-Pareja, Intel Corp.; R. Shekhar, Univ. of Maryland/Baltimore [6063-01]
- 9:00 am: **Toward real-time stereoscopic depth reconstruction in laparoscopic surgery**, B. J. McCullagh, F. P. Shevlin, The Univ. of Dublin, Trinity College (Ireland) [6063-02]
- 9:20 am: **Real-time wavelet denoising with edge enhancement for medical x-ray imaging**, G. Luo, D. Osypiw, Buckinghamshire Chilterns Univ. College (United Kingdom) [6063-03]
- Coffee Break 10:00 to 10:30 am

SESSION 2

Conv. Ctr. Room B3 Mon. 10:30 am to 12:00 pm

Video Processing

Chair: **Carlos R. Castro-Pareja**, Intel Corp.

- 10:30 am: **Real-time high-level video understanding using data warehouse (Invited Paper)**, B. Lienard, X. Desurmont, B. Barrie, J. Delaigle, Multitel A.S.B.L. (Belgium) [6063-05]
- 11:00 am: **Video surveillance using distance maps**, T. E. Schouten, H. C. Kuppens, Radboud Univ. Nijmegen (Netherlands); E. L. van den Broek, Vrije Univ. Amsterdam (Netherlands) and Katholieke Univ./Nijmegen (Netherlands) [6063-06]
- 11:20 am: **Vehicle traffic video data real-time processing**, M. Andreae, W. K. Cheng, Massachusetts Institute of Technology [6063-07]
- 11:40 am: **Vehicle counting system using real-time video processing**, P. Crisostomo-Romero, Pontificia Univ. Católica del Perú [6063-08]
- Lunch Break 12:00 to 1:30 pm

SESSION 3

Conv. Ctr. Room B3 Mon. 1:30 to 3:00 pm

Algorithms

Chair: **Xavier Desurmont**, Multitel A.S.B.L. (Belgium)

- 1:30 pm: **Real-time auto white balancing using DWT-based multiscale clustering (Invited Paper)**, N. Kehtarnavaz, N. Kim, M. N. Gamadia, The Univ. of Texas at Dallas [6063-09]
- 2:00 pm: **Real-time antialiasing using adaptive directional filtering**, P. Rokita, Politechnika Warszawska (Poland) [6063-10]
- 2:20 pm: **A fast eye detector using corners, color, and edges**, L. Chen, C. Grecos, Loughborough Univ. (United Kingdom) [6063-11]
- 2:40 pm: **Real-time construction of covariance matrices for arbitrary size image windows**, F. M. Porikli, O. Tuzel, Mitsubishi Electric Research Labs. [6063-12]
- Coffee Break 3:00 to 3:30 pm

SESSION 4

Conv. Ctr. Room B3 Mon. 3:30 to 5:40 pm

Hardware

Chair: **Mohamed Akil**, École Supérieure d'Ingénieurs en Électronique et Électrotechnique (France)

- 3:30 pm: **High-performance VLSI architecture for adaptive scaling (Invited Paper)**, P. P. Dang, STMicroelectronics [6063-13]
- 4:00 pm: **Architecture for hardware driven image inspection based on FPGAs**, J. Fuertler, J. Brodersen, Austrian Research Ctrs. GmbH - Seibersdorf (Austria); P. Roessler, Technische Univ. Wien (Austria); K. J. Mayer, Austrian Research Ctrs. GmbH - Seibersdorf (Austria); G. Cadek, C. Eckel, H. Nachtnebel, Technische Univ. Wien (Austria) [6063-14]
- 4:20 pm: **Using a field programmable object array (FPOA) to accelerate image processing**, S. Riley, MathStar, Inc. [6063-15]
- 4:40 pm: **Novel windowing technique realized in FPGA for radar system**, E. Escamilla-Hernández, Instituto Politécnico Nacional (Mexico); V. F. Kravchenko, Instituto Politécnico Nacional (Mexico) and Institute of Radio Engineering and Electronics (Russia); V. I. Ponomaryov, Instituto Politécnico Nacional (Mexico) [6063-16]
- 5:00 pm: **Real-time hardware for a new 3D display**, M. Akil, B. Kaufmann, École Supérieure d'Ingénieurs en Électronique et Électrotechnique (France) [6063-17]
- 5:20 pm: **A rapid prototyping methodology to implement and optimize image processing algorithms for FPGAs**, M. Akil, P. Niang, T. Grandpierre, École Supérieure d'Ingénieurs en Électronique et Électrotechnique (France) [6063-18]

Tuesday 17 January

Plenary Speaker **Tues. 8:30 to 9:15 am**
Marriott Ballroom 1-6
Image Processing: Interconnections
Thomas S. Huang, Beckman Institute for Advanced Science and
Technology, Univ. of Illinois at Urbana-Champaign
See p. 7 for details.

✓ Posters and Demonstrations-Tuesday

Demonstrations **5:30 to 8:30 pm**

*A symposium-wide demonstration session will be open to attendees
5:30 to 8:30 pm Tuesday evening in Conv. Ctr. Exhibit Hall 1.
Demonstrators will provide interactive, hands-on demonstrations of a
wide-range of products related to Electronic Imaging.*

Posters **5:30 to 7:00 pm**

*Posters will be placed on display after 10:00 am in Exhibit Hall 1. A
poster session, with authors present at their posters, will be held
Tuesday evening, 5:30 to 7:00 pm.*

- ✓ **An efficient illuminance-reflectance nonlinear video stream enhancement model**, L. Tao, V. K. Asari, Old Dominion Univ. [6063-19]
- ✓ **A novel two-pass hexagonal search algorithm for motion estimation**, Y. Wu, The Univ. of Reading (United Kingdom) .. [6063-21]
- ✓ **Real-time image processing based on robust linear combinations of order statistics**, F. J. Gallegos-Funes, J. L. Varela-Benitez, V. I. Ponomaryov, Instituto Politécnico Nacional (Mexico) [6063-22]
- ✓ **A new concept of real-time security camera monitoring with privacy protection by masking moving objects**, K. Yabuta, H. Kitazawa, T. Tanaka, Tokyo Univ. of Agriculture and Technology (Japan) [6063-23]
- ✓ **Online monitoring for wood pieces on a moving conveyor belt**, W. Wang, Chongqing Univ. of Posts and Telecommunications (China) [6063-24]
- ✓ **A hardware-accelerated approach to computing multiple image similarity measures from joint histogram**, C. R. Castro-Pareja, Intel Corp.; R. Shekhar, Univ. of Maryland/Baltimore [6063-25]
- ✓ **Real-time human detection by shape and motion**, H. Ran, Wuhan Univ. of Technology (China) [6063-26]
- ✓ **Uranus: an environment for rapid prototyping of real-time video processing based on FPGA**, M. A. Nuño-Maganda, V. H. Rosales-Hernández, L. N. Castillo-Jimenez, G. Sosa-Ramírez, M. O. Arias-Estrada, Instituto Nacional de Astrofísica, Óptica y Electrónica (Mexico) [6063-31]
- ✓ **Determination of traffic intensity from camera images using image processing and pattern recognition techniques**, M. Mehrubeoglu, Texas A&M Univ./Corpus Christi; L. McLauchlan, Texas A&M Univ./Kingsville [6063-32]

Conference 6064A • Conv. Ctr. Room C2

Monday-Tuesday 16-17 January 2006 • Part of Proceedings of SPIE Vol. 6064
Image Processing: Algorithms and Systems, Neural Networks and Machine Learning

Image Processing: Algorithms and Systems V

Conference Chairs: **Edward R. Dougherty**, Texas A&M Univ.; **Jaakko T. Astola**, Tampere Univ. of Technology (Finland); **Karen O. Egiazarian**, Tampere Univ. of Technology (Finland)

Program Committee: **Til Aach**, RWTH Aachen (Germany); **Sos S. Aгаian**, The Univ. of Texas at San Antonio; **Junior Barrera**, Univ. de São Paulo (Brazil); **Reiner Creutzburg**, Fachhochschule Brandenburg (Germany); **Paul D. Gader**, Univ. of Florida; **Atanas P. Gotchev**, Tampere Univ. of Technology (Finland); **John C. Handley**, Xerox Corp.; **Vladimir V. Lukin**, National Aerospace Univ. (Ukraine); **Stephen Marshall**, Univ. of Strathclyde (United Kingdom); **Françoise J. Prêteux**, Institut National des Télécommunications (France); **Giovanni Ramponi**, Univ. Degli Studi di Trieste (Italy); **Jagath K. Samarabandu**, The Univ. of Western Ontario (Canada); **Akira Taguchi**, Musashi Institute of Technology (Japan)

Monday 16 January

SESSION 1

Conv. Ctr. Room C2 Mon. 9:00 am to 12:10 pm

Image Processing Algorithms

- 9:00 am: **Affine invariant surface evolutions for 3D image segmentation**, Y. Rathi, Georgia Institute of Technology; P. Olver, G. Sapiro, Univ. of Minnesota; A. R. Tannenbaum, Georgia Institute of Technology [6064A-01]
- 9:20 am: **Iterative Markovian estimation of mass functions in Dempster Shafer evidence theory: application to multisensor image segmentation**, L. Bentabet, M. Jiang, Bishop's Univ. (Canada) [6064A-02]
- 9:40 am: **Progressive halftoning by Perona-Malik error diffusion and stochastic flipping**, J. J. Shen, Univ. of Minnesota [6064A-03]
- 10:00 am: **Edge-based stochastic active contours for medical imaging**, J. J. Trisnel, A. R. Tannenbaum, Georgia Institute of Technology [6064A-04]
- Coffee Break 10:20 to 10:50 am
- 10:50 am: **Multiple wavelet coherence analysis**, S. C. Olhede, G. Metikas, Imperial College London (United Kingdom) [6064A-05]
- 11:10 am: **New class of interpolation methods based on discretized lie group transforms**, A. Zaratsyan, J. Patera, Univ. de Montréal (Canada); H. Zhu, York Univ. (Canada) [6064A-06]
- 11:30 am: **Optimization procedures for the estimation of phase portrait parameters in orientation fields**, F. J. Ayres, R. M. Rangayyan, Univ. of Calgary (Canada) [6064A-07]
- 11:50 am: **Optimized gradient filters for hexagonal matrices**, T. Shima, S. Saito, Tokyo Institute of Technology (Japan); M. Nakajima, Tokyo Institute of Technology (Japan) and National Institute of Informatics (Japan) [6064A-08]
- Lunch Break 12:10 to 2:00 pm

SESSION 2

Conv. Ctr. Room C2 Mon. 2:00 to 3:00 pm

Efficient Algorithms

- 2:00 pm: **Super-fast Fourier transform**, S. S. Aгаian, O. Caglayan, The Univ. of Texas at San Antonio [6064A-09]
- 2:20 pm: **A high-speed rotation method for binary document images based on coordinate operation of run data**, Y. Shima, H. Ohya, Meisei Univ. (Japan) [6064A-11]
- 2:40 pm: **A hardware implementation of the discrete Pascal transform for image processing**, T. J. Goodman, M. F. Aburdene, Bucknell Univ. [6064A-12]
- Coffee Break 3:00 to 3:30 pm

SESSION 3

Conv. Ctr. Room C2 Mon. 3:30 to 4:50 pm

Image Processing Systems

- 3:30 pm: **Using clustering for document reconstruction**, A. Ukovich, A. Zacchigna, G. Ramponi, G. Schoier, Univ. Degli Studi di Trieste (Italy) [6064A-13]
- 3:50 pm: **Automatic detection and tracking of reappearing targets in forward-looking infrared imagery**, A. Bal, M. S. Alam, Univ. of South Alabama [6064A-14]
- 4:10 pm: **Robust human motion detection via fuzzy set based image understanding**, Q. Li, J. You, The Hong Kong Polytechnic Univ. (Hong Kong China) [6064A-16]
- 4:30 pm: **k-max: segmentation based on selection of max-tree deep nodes**, A. G. Silva, S. C. Felipussi, G. L. F. Cassol, Univ. do Estado de Santa Catarina (Brazil); R. de Alencar Lotufo, Univ. Estadual de Campinas (Brazil) [6064A-17]

Tuesday 17 January

Plenary Speaker Tues. 8:30 to 9:15 am

Marriott Ballroom 1-6

Image Processing: Interconnections

Thomas S. Huang, Beckman Institute for Advanced Science and Technology, Univ. of Illinois at Urbana-Champaign

See p. 7 for details.

SESSION 4

Conv. Ctr. Room C2 Tues. 9:40 to 11:50 am

Image Processing Methods

- 9:40 am: **Shape-adaptive DCT for denoising and image reconstruction**, A. Foi, K. Dabov, V. Katkovnik, K. O. Egiazarian, Tampere Univ. of Technology (Finland) [6064A-18]
- 10:00 am: **Anisotropic filtering with nonlinear structure tensors**, C. A. Castaño Moraga, J. Ruiz-Alzola, Univ. de Las Palmas de Gran Canaria (Spain) [6064A-19]
- Coffee Break 10:20 to 10:50 am
- 10:50 am: **A modified wavelet transformation based method of linear object extraction**, T. Chen, Univ. of South Carolina [6064A-20]
- 11:10 am: **2D approaches to 3D watermarking: state of the art and perspectives**, M. P. Mitrea, S. A. Duta, F. J. Prêteux, Institut National des Télécommunications (France) [6064A-21]
- 11:30 am: **Region-based perceptual grouping: a cooperative approach based on Dempster-Shafer theory**, N. Zlatoff, B. Tellez, A. M. Baskurt, Univ. Claude Bernard Lyon 1 (France) [6064A-22]
- Lunch/Exhibition Break 11:50 am to 1:40 pm

SESSION 5

Conv. Ctr. Room C2 Tues. 1:40 to 3:00 pm

Biomedical Image Processing

- 1:40 pm: **Study of muscular deformation based on surface slope estimation**, M. Carli, M. Goffredo, M. Schmid, A. Neri, Univ. degli Studi di Roma Tre (Italy) [6064A-23]
- 2:00 pm: **An automated diagnosis approach based on histopathological images**, M. C. d'Ornellas, C. C. Danesi, J. A. T. Borges da Costa, Univ. Federal de Santa Maria (Brazil) [6064A-24]
- 2:20 pm: **Variational segmentation of x-ray image with overlapped objects**, G. Yu, NucTech Co. Ltd. (China); L. Zhang, J. Zhang, Y. Xing, H. Gao, Tsinghua Univ. (China) [6064A-25]
- 2:40 pm: **Image segmentation for automated dental identification**, E. Haj Said, D. E. M. Nassar, H. H. Ammar, West Virginia Univ. [6064A-26]
- Coffee Break 3:00 to 3:30 pm

SESSION 6

Conv. Ctr. Room C2 Tues. 3:30 to 5:30 pm

Algorithms and Systems

- 3:30 pm: **Deblending of the UV photometry in GALEX deep surveys using optical priors in the visible wavelengths**, A. Llebaria, Lab. d'Astrophysique de Marseille (France); M. Guillaume, D. Aymeric, Ecole Generaliste d'Ingenieurs de Marseille (France); B. Milliard, S. Arnauts, Lab. d'Astrophysique de Marseille (France) [6064A-27]
- 3:50 pm: **Comparative study of logarithmic enhancement algorithms with performance measure**, E. J. Wharton, Tufts Univ.; S. S. Agaian, The Univ. of Texas at San Antonio; K. A. Panetta, Tufts Univ. [6064A-28]
- 4:10 pm: **MMW video sequence denoising and enhancement in concealed weapons detection applications**, X. Wei, H. Chen, The Univ. of Texas at Arlington; P. K. Varshney, Syracuse Univ. [6064A-29]
- 4:30 pm: **Image denoising with block-matching and 3D filtering**, K. Dabov, A. Foi, V. Katkovich, K. O. Egiazarian, Tampere Univ. of Technology (Finland) [6064A-30]
- 4:50 pm: **An algorithm for the enhancement of images of large dynamic range**, F. Hassan, J. E. Carletta, Univ. of Akron [6064A-31]
- 5:10 pm: **Nonlinear image enhancement to improve face detection in complex lighting environment**, L. Tao, M. Seow, V. K. Asari, Old Dominion Univ. [6064A-32]

✓ Posters and Demonstrations-Tuesday

Demonstrations. 5:30 to 8:30 pm

A symposium-wide demonstration session will be open to attendees 5:30 to 8:30 pm Tuesday evening in Conv. Ctr. Exhibit Hall 1. Demonstrators will provide interactive, hands-on demonstrations of a wide-range of products related to Electronic Imaging.

Posters 5:30 to 7:00 pm

Posters will be placed on display after 10:00 am in Exhibit Hall 1. A poster session, with authors present at their posters, will be held Tuesday evening, 5:30 to 7:00 pm.

- ✓ **Noise image enhancement on Hölder function spaces**, M. Lee, National Taiwan Ocean Univ. (Taiwan) [6064A-33]
- ✓ **Ad hoc segmentation pipeline for microarray image analysis**, S. Battiato, G. Di Blasi, G. M. Farinella, G. Gallo, G. C. Guarnera, Univ. di Catania (Italy) [6064A-34]
- ✓ **Color transient improvement via range detection**, G. S. Shin, M. G. Kang, Yonsei Univ. (South Korea) [6064A-35]
- ✓ **For fast classification and segmentation of high-resolution images of multiple and complicated colonies**, W. Wang, Chongqing Univ. of Posts and Telecommunications (China) [6064A-36]
- ✓ **Spatially adaptive multiresolution multispectral image fusion based on Bayesian approach**, J. H. Park, M. G. Kang, Yonsei Univ. (South Korea) [6064A-37]
- ✓ **Segmentation of microspheres in ultrahigh density microsphere-based assays**, A. Mathur, D. M. Kelso, Northwestern Univ. [6064A-38]
- ✓ **Discrete Gould transform and its applications**, M. F. Aburdene, H. M. Le, Bucknell Univ. [6064A-39]
- ✓ **The application of image filters combined with the nonlinear regression analysis on optical autofocusing**, M. Lee, W. Hsu, National Kaohsiung Normal Univ. (Taiwan); T. Lin, National Taiwan Univ. (Taiwan) [6064A-40]
- ✓ **Crease enhancement and the segmentation of topographic images**, H. C. Morris, San José State Univ. [6064A-41]
- ✓ **A multiscale approach to contour detection and texture suppression**, G. Papari, Rijksuniv. Groningen (Netherlands); P. Campisi, Univ. degli Studi Roma Tre (Italy); N. Petkov, Rijksuniv. Groningen (Netherlands); A. Neri, Univ. degli Studi Roma Tre (Italy) ... [6064A-43]
- ✓ **A heuristic approach for the extraction of region and boundary of mammalian cells in bio-electric images**, L. Tao, V. K. Asari, Old Dominion Univ. [6064A-44]
- ✓ **Lip segmentation and tracking for facial palsy**, M. Park, J. Seo, K. S. Park, Seoul National Univ. (South Korea) [6064A-45]
- ✓ **A multithreshold algorithm based on intensity distribution**, D. Chen, M. Sarhadi, Brunel Univ. (United Kingdom) [6064A-46]
- ✓ **An efficient multiresolution GA approach to dental image alignment**, D. E. M. Nassar, M. Ogirala, D. A. Adjero, H. H. Ammar, West Virginia Univ. [6064A-47]
- ✓ **Phase unwrapping by means of finite differences**, L. I. Olivos-Pérez, E. de la Rosa Miranda, L. R. Berriel-Valdos, R. Ramos-López, Instituto Nacional de Astrofísica, Óptica y Electrónica (Mexico) [6064A-48]

Conference 6064B • Conv. Ctr. Room C2

Tuesday-Wednesday 17-18 January 2006 • Part of Proceedings of SPIE Vol. 6064
Image Processing: Algorithms and Systems, Neural Networks and Machine Learning

Applications of Neural Networks and Machine Learning in Image Processing X

Conference Chairs: **Nasser M. Nasrabadi**, Army Research Lab.; **Syed A. Rizvi**, CUNY/College of Staten Island

Program Committee: **Pierre Baldi**, California Institute of Technology; **Yoshua Bengio**, Univ. de Montréal (Canada); **Terry M. Caelli**, Curtin Univ. of Technology (Australia); **Rama Chellappa**, Univ. of Maryland/College Park; **Chang Y. Choo**, San José State Univ.; **Sandor Z. Der**, Aerospace Corp.; **Edward R. Dougherty**, Texas A&M Univ.; **Kunihiko Fukushima**, Tokyo Univ. of Technology (Japan); **Erol Gelenbe**, Imperial College London (United Kingdom); **David H. Haussler**, Univ. of California/Santa Cruz; **Nicolaos B. Karayiannis**, Univ. of Houston; **Bart Kosko**, Univ. of Southern California; **Sun-Yuan Kung**, Princeton Univ.; **Richard P. Lippmann**, MIT Lincoln Lab.; **Erkki Oja**, Helsinki Univ. of Technology (Finland); **Sankar K. Pal**, Indian Statistical Institute (India); **Tomaso A. Poggio**, MIT Artificial Intelligence Lab.; **Christoph von der Malsburg**, Univ. of Southern California; **Jacek M. Zurada**, Univ. of Louisville

Tuesday 17 January

Plenary Speaker **Tues. 8:30 to 9:15 am**
Marriott Ballroom 1-6
Image Processing: Interconnections
Thomas S. Huang, Beckman Institute for Advanced Science and Technology, Univ. of Illinois at Urbana-Champaign
See p. 7 for details.

✓ Posters and Demonstrations-Tuesday

Demonstrations **5:30 to 8:30 pm**

A symposium-wide demonstration session will be open to attendees 5:30 to 8:30 pm Tuesday evening in Conv. Ctr. Exhibit Hall 1. Demonstrators will provide interactive, hands-on demonstrations of a wide-range of products related to Electronic Imaging.

Posters **5:30 to 7:00 pm**

Posters will be placed on display after 10:00 am in Exhibit Hall 1. A poster session, with authors present at their posters, will be held Tuesday evening, 5:30 to 7:00 pm.

- ✓ **Key-text spotting in documentary videos using Adaboost**, M. Lalonde, L. Gagnon, CRIM (Canada) [6064B-65]
- ✓ **Research on classifying performance of SVMs with basic kernel in HCCR**, L. Sun, YanTai Univ. (China) [6064B-67]
- ✓ **Face recognition based on HMM in compressed domain**, H. Wang, G. Feng, Sun Yat-sen Univ. (China) [6064B-68]
- ✓ **Application of ANN and DT on medium resolution ASTER image to model gully network in Southern Italy**, A. Ghaffari, P. M. Mather, G. Priestnall, M. L. Clarke, The Univ. of Nottingham (United Kingdom) [6064B-69]

Wednesday 18 January

Plenary Speaker **Wed. 8:30 to 9:15 am**
Marriott Ballroom 1-6
Computational Imaging Methods for Functional Brain Mapping and Molecular Imaging
Richard Leahy, Univ. of Southern California
See p. 7 for details.

SESSION 7

Conv. Ctr. Room C2 **Wed. 9:30 to 10:30 am**

Kernel-based Learning for Detection and Shape Analysis

Chair: Heesung Kwon, Army Research Lab.

9:30 am: **Nonlinear shape prior from Kernel space for geometric active contours**, S. Dambreville, Y. Rathi, A. R. Tannenbaum, Georgia Institute of Technology [6064B-49]

9:50 am: **Kernel subspace matched target detectors**, H. Kwon, N. M. Nasrabadi, Army Research Lab. [6064B-50]

10:10 am: **Statistical shape analysis using kernel PCA**, Y. Rathi, S. Dambreville, A. R. Tannenbaum, Georgia Institute of Technology[6064B-51]

Coffee Break 10:30 to 11:00 am

SESSION 8

Conv. Ctr. Room C2 **Wed. 11:00 to 11:20 am**

Fuzzy Clustering

Chair: Heesung Kwon, Army Research Lab.

11:00 am: **Segmentation and enhancement of digital copies using a new fuzzy clustering method**, M. N. Ahmed, B. E. Cooper, Lexmark International, Inc. [6064B-52]

SESSION 9

Conv. Ctr. Room C2 Wed. 11:20 to 11:40 am

Independent Component Analysis, Adaboost for Recognition

Chair: Syed A. Rizvi, College of Staten Island/CUNY

11:20 am: **2D/3D facial feature extraction**, B. Sankur, L. Akarun, H. Cinar, A. Ali Salah, Bogaziçi Univ. (Turkey) [6064B-54]

Lunch/Exhibition Break 11:40 am to 1:20 pm

SESSION 10

Conv. Ctr. Room C2 Wed. 1:20 to 3:50 pm

Neural Networks Applications for Manifold Learning, Recognition, Color Perception, and Compression

Chair: Syed A. Rizvi, College of Staten Island/CUNY

1:20 pm: **Noniterative neural network learning of an N-dimension curve representing the dynamic history of a time varying pattern**, C. J. Hu, Southern Illinois Univ. [6064B-56]

1:40 pm: **Manifold of color perception: color constancy using a nonlinear line attractor**, V. K. Asari, M. Seow, Old Dominion Univ. [6064B-57]

2:00 pm: **A novel neural net application for image compression**, H. S. Soliman, M. Omari, New Mexico Institute of Mining and Technology [6064B-58]

2:20 pm: **Toward content-based object recognition with image primitives**, G. Wang, J. M. Kinser, George Mason Univ. [6064B-59]

2:40 pm: **Translation invariance in a network of oscillatory units**, A. R. Rao, G. A. Cecchi, C. Peck, J. Kozloski, IBM Corp. [6064B-60]

Coffee Break 3:00 to 3:30 pm

3:30 pm: **Efficient learning and recognition using segmented analytical data of an edge-detected 2D image**, C. J. Hu, Southern Illinois Univ. [6064B-61]

SESSION 11

Conv. Ctr. Room C2 Wed. 3:50 to 4:50 pm

Support Vector Machine and Neural Networks for Face Recognition, Detection, and Classification

Chair: Nasser M. Nasrabadi, Army Research Lab.

3:50 pm: **Support vector machine as digital image watermark detector**, P. H. H. Then, Swinburne Univ. of Technology (Malaysia); Y. C. Wang, Univ. Malaysia Sarawak (Malaysia) [6064B-62]

4:10 pm: **Neural networks approach to high vertical resolution atmospheric temperature profile retrieval from spaceborne high spectral resolution infrared sounder measurements**, D. Jiang, C. Dong, Hunan Meteorological Bureau (China) [6064B-63]

4:30 pm: **Probabilistic multiresolution human classification**, H. Ran, J. Tu, Wuhan Univ. of Technology (China) [6064B-64]

Conference 6065 • Conv. Ctr. Room A4

Monday-Wednesday 16-18 January 2006 • Proceedings of SPIE Vol. 6065

Computational Imaging IV

Conference Chairs: **Charles A. Bouman**, Purdue Univ.; **Eric L. Miller**, Northeastern Univ.; **Ilya Pollak**, Purdue Univ.

Program Committee: **Thomas S. Denney, Jr.**, Auburn Univ.; **Peter C. Doerschuk**, Purdue Univ.; **Maya R. Gupta**, Univ. of Washington; **Peyman Milanfar**, Univ. of California/Santa Cruz; **Joseph A. O'Sullivan**, Washington Univ. in St. Louis; **Zygmunt Pizlo**, Purdue Univ.; **Stanley J. Reeves**, Auburn Univ.; **Yongyi Yang**, Illinois Institute of Technology; **Yibin Zheng**, Univ. of Virginia

Monday 16 January

SESSION 1

Conv. Ctr. Room A4 Mon. 8:30 to 9:00 am

Keynote Presentation I

Chair: **Charles A. Bouman**, Purdue Univ.

Keynote

8:30 am: **Keynote (Invited Paper)**, M. V. de Hoop, Purdue Univ. [6065-01]

SESSION 2

Conv. Ctr. Room A4 Mon. 9:00 to 11:10 am

Hierarchical and Graph-based Image Analysis

Chair: **Peyman Milanfar**, Univ. of California/Santa Cruz

9:00 am: **Modeling hierarchical structure of images with stochastic grammars**, W. Wang, T. Wong, I. Pollak, C. A. Bouman, M. P. Harper, Purdue Univ. [6065-02]

9:20 am: **Multiresolution analysis of digital images using the continuous extension of discrete group transforms**, M. Germain, J. Patera, A. Zaratsyan, Univ. de Montréal (Canada) [6065-03]

9:40 am: **Modeling multiscale differential pixel statistics with applications**, D. Odom, P. Milanfar, Univ. of California/Santa Cruz [6065-04]

Coffee Break 10:00 to 10:30 am

10:30 am: **Graph-based 3D object classification**, S. Baloch, A. H. Krim, North Carolina State Univ. [6065-05]

10:50 am: **Compression via optimal basis selection in large tree-structured dictionaries**, Y. Huang, Purdue Univ. [6065-06]

SESSION 3

Conv. Ctr. Room A4 Mon. 11:10 am to 12:10 pm

Reconstruction from Sparse Data

Chair: **Ilya Pollak**, Purdue Univ.

11:10 am: **Compressed sensing in noisy imaging environments**, J. Haupt, R. Castro, R. D. Nowak, Univ. of Wisconsin/Madison ... [6065-07]

11:30 am: **Stable signal recovery from incomplete and inaccurate observations**, J. K. Romberg, California Institute of Technology [6065-08]

11:50 am: **A compressed sensing camera: new theory and an implementation using digital micromirrors**, D. Takhar, M. B. Wakin, M. Duarte, D. Baron, K. F. Kelly, R. G. Baraniuk, Rice Univ. [6065-09]

Lunch Break 12:10 to 1:40 pm

SESSION 4

Conv. Ctr. Room A4 Mon. 1:40 to 3:00 pm

Microscopy

Chair: **Peter C. Doerschuk**, Purdue Univ.

1:40 pm: **A fast algorithm for 3D reconstruction from unoriented projections and cryo-electron microscopy of viruses**, J. Lee, Y. Zheng, P. C. Doerschuk, Purdue Univ. [6065-10]

2:00 pm: **Spatially adaptive 3D inverse for optical sectioning**, D. V. Paliy, V. Katkovnik, K. O. Egiazarian, Tampere Univ. of Technology (Finland) [6065-11]

2:20 pm: **On soft clipping of Zernike moments for deblurring and enhancement of optical point spread functions**, N. Becherer, J. Hesser, Univ. Mannheim (Germany) [6065-12]

2:40 pm: **Adaptive sampling for atomic force microscopy with system level motion constraints**, H. Cheng, G. T. C. Chiu, Purdue Univ. [6065-13]

Coffee Break 3:00 to 3:30 pm

SESSION 5

Conv. Ctr. Room A4 Mon. 3:30 to 5:10 pm

Inverse Problems

Chair: **Thomas S. Denney, Jr.**, Auburn Univ.

3:30 pm: **Bayesian image reconstruction from Fourier-domain samples using prior edge information: convergence and parameter sensitivity**, T. S. Denney, Jr., S. J. Reeves, Auburn Univ. [6065-14]

3:50 pm: **Thin digital imaging systems using focal plane coding**, A. D. Portnoy, J. P. Guo, N. P. Pitsianis, D. J. Brady, Duke Univ.; M. A. Fiddy, Univ. of North Carolina/Charlotte; M. R. Feldman, R. D. Te Kolste, Digital Optics Corp. [6065-15]

4:10 pm: **3D reconstructions from spherically averaged Fourier transform magnitude and solution x-ray scattering experiments**, Y. Hwang, P. C. Doerschuk, Purdue Univ. [6065-16]

4:30 pm: **Computed spectroscopy using segmented apertures**, R. T. Hoctor, F. W. Wheeler, GE Global Research; E. B. Barrett, Lockheed Martin Corp. [6065-17]

4:50 pm: **Preconditioned conjugate gradient without linesearch: a comparison with the half-quadratic approach for edge-preserving image restoration**, C. Labat, J. Idier, Institute of Research in Communications and Cybernetics of Nantes (France) [6065-18]

Tuesday 17 January

Plenary Speaker Tues. 8:30 to 9:15 am
Marriott Ballroom 1-6
Image Processing: Interconnections
Thomas S. Huang, Beckman Institute for Advanced Science and Technology, Univ. of Illinois at Urbana-Champaign
See p. 7 for details.

SESSION 6

Conv. Ctr. Room A4 Tues. 9:30 to 10:00 am

Keynote Presentation II

Chair: Eric L. Miller, Northeastern Univ.

9:30 am: **Computational methods for image restoration, image segmentation, and texture modeling (Invited Paper)**, G. Chung, T. M. Le, L. H. Lieu, N. Tanushev, L. Vese, Univ. of California/Los Angeles [6065-19]

SESSION 7

Conv. Ctr. Room A4 Tues. 10:00 am to 12:10 pm

Image and Video Analysis

Chair: Mireille Boutin, Purdue Univ.

10:00 am: **An adaptive model for restoration of optically distorted video frames**, D. Li, Georgia Institute of Technology; M. J. T. Smith, Purdue Univ.; R. M. Mersereau, Georgia Institute of Technology [6065-20]
Coffee Break 10:20 to 10:50 am
10:50 am: **Resource-driven content adaptation**, Y. Lu, D. S. Ebert, E. J. Delp III, Purdue Univ. [6065-21]
11:10 am: **Algebraic methods for structure from motion**, M. Boutin, J. Zhang, D. G. Aliaga, Purdue Univ. [6065-22]
11:30 am: **A maximum entropy kernel density estimator with applications to function interpolation and texture segmentation**, N. Balakrishnan, D. Schonfeld, Univ. of Illinois at Chicago [6065-23]
11:50 am: **Multiple watermarking: a vector space projection approach**, O. Altun, G. Sharma, M. Bocko, Univ. of Rochester [6065-24]
Lunch/Exhibition Break 12:10 to 1:40 pm

SESSION 8

Conv. Ctr. Room A4 Tues. 1:40 to 3:00 pm

Biomedical Imaging

Chair: Miles N. Wernick, Illinois Institute of Technology

1:40 pm: **Spherical harmonics for shape-based inverse problems, as applied to electrical impedance tomography**, S. Babaeizadeh, D. H. Brooks, Northeastern Univ. [6065-25]
2:00 pm: **3D nonlinear multigrid algorithm for direct reconstruction of chromophore concentrations in diffuse optical tomography**, J. C. Ye, Korea Advanced Institute of Science and Technology (South Korea) [6065-26]
2:20 pm: **Adaptation of fast marching methods to subcellular modeling**, A. Chikando, J. M. Kinser, George Mason Univ. [6065-27]
2:40 pm: **Machine learning of human responses to images**, M. N. Wernick, Y. Yang, J. G. Brankov, L. Wei, Illinois Institute of Technology; I. M. El-Naqa, Washington Univ. in St. Louis; N. P. Galatsanos, Univ. of Ioannina (Greece) [6065-28]
Coffee Break 3:00 to 3:30 pm

SESSION 9

Conv. Ctr. Room A4 Tues. 3:30 to 5:50 pm

Tomography

Chair: Joseph A. O'Sullivan, Washington Univ. in St. Louis

3:30 pm: **Image reconstruction algorithms for a novel PET system with a half-ring insert**, D. Pal, J. A. O'Sullivan, H. Wu, M. Janecek, Y. C. Tai, Washington Univ. in St. Louis [6065-29]
3:50 pm: **Improved sampling of parallel projection in cylindrical PET scanners**, B. Farsaii, SUNY/Univ. at Buffalo [6065-30]
4:10 pm: **A Bayesian approach to tomography of multiply scattered beams**, Z. H. Levine, National Institute of Standards and Technology [6065-31]
4:30 pm: **Progress in multiple-image radiography**, M. N. Wernick, J. G. Brankov, Y. Yang, G. Khelashvili, Illinois Institute of Technology; D. Chapman, Univ. of Saskatchewan (Canada); I. Mondal, B. Marquet, Illinois Institute of Technology; Z. Zhong, Brookhaven National Lab. [6065-32]
4:50 pm: **A recursive filter for noise reduction in tomographic imaging**, J. Thibault, GE Medical Systems; C. A. Bouman, Purdue Univ.; J. Hsieh, GE Medical Systems; K. D. Sauer, Univ. of Notre Dame [6065-33]
5:10 pm: **A branch-less distance driven projection and backprojection algorithm**, S. Basu, General Electric Co.; B. De Man, GE Global Research [6065-34]
5:30 pm: **Cupping artifacts analysis and correction for a FPD-based cone-beam CT**, L. Zhang, H. Gao, Z. Chen, S. Li, Y. Xing, Tsinghua Univ. (China) [6065-35]

✓ **Posters and Demonstrations-Tuesday**

Demonstrations 5:30 to 8:30 pm

A symposium-wide demonstration session will be open to attendees 5:30 to 8:30 pm Tuesday evening in Conv. Ctr. Exhibit Hall 1. Demonstrators will provide interactive, hands-on demonstrations of a wide-range of products related to Electronic Imaging.

Posters 5:30 to 7:00 pm

Posters will be placed on display after 10:00 am in Exhibit Hall 1. A poster session, with authors present at their posters, will be held Tuesday evening, 5:30 to 7:00 pm.

- ✓ **A block-iterative deterministic annealing algorithm for Bayesian tomographic reconstruction**, S. Lee, Paichai Univ. (South Korea) [6065-44]
- ✓ **Deinterlacing in spatial and temporal domain**, I. Kim, C. Lee, Yonsei Univ. (South Korea) [6065-46]
- ✓ **Cosine transform generalized to lie groups SU(2)xSU(2), O(5) and SU(2)xSU(2)xSU(2): application to digital image processing**, M. Germain, J. Patera, Univ. de Montréal (Canada) [6065-47]
- ✓ **A prioritized and adaptive approach to volumetric seeded region growing using texture descriptors**, N. J. Backman, Whitworth College; B. W. Whitney, Northern Kentucky Univ.; J. D. Furst, D. S. Raicu, DePaul Univ. [6065-48]
- ✓ **A fast MAP-based superresolution algorithm for general motion**, M. Tanaka, M. Okutomi, Tokyo Institute of Technology (Japan) . . [6065-49]
- ✓ **Image deblurring by the combined use of a superresolution technique and inverse filtering**, Y. Yamada, K. Nakamae, Osaka Univ. (Japan); H. Fujioka, Fukui Univ. of Technology (Japan) [6065-50]

Conference 6065 • Conv. Ctr. Room A4

Wednesday 18 January

Plenary Speaker Wed. 8:30 to 9:15 am
Marriott Ballroom 1-6
Computational Imaging Methods for Functional Brain Mapping and Molecular Imaging
Richard Leahy, Univ. of Southern California
See p. 7 for details.

SESSION 10

Conv. Ctr. Room A4 Wed. 9:30 to 10:30 am

Color

Chair: Stanley J. Reeves, Auburn Univ.

- 9:30 am: **Estimation of color filter array data from JPEG images for improved demosaicing**, W. Feng, S. J. Reeves, Auburn Univ. . . [6065-36]
- 9:50 am: **Separation of irradiance and reflectance from observed color images by logarithmical nonlinear diffusion process**, T. Saito, H. Takahashi, T. Komatsu, Kanagawa Univ. (Japan) [6065-37]
- 10:10 am: **Novel scanner characterization method for color measurement and diagnostics applications**, B. Lee, Thomson Corporate Research; R. Bala, Xerox Corp.; G. Sharma, Univ. of Rochester . [6065-38]
- Coffee Break 10:30 to 11:00 am

SESSION 11

Conv. Ctr. Room A4 Wed. 11:00 am to 12:20 pm

Image Modeling and Analysis

Chair: Zygmunt Pizlo, Purdue Univ.

- 11:00 am: **Elastic surface registration by parameterization optimization in spectral space**, F. G. Vadakkumpadan, Y. Tong, Y. Sun, Purdue Univ. [6065-39]
- 11:20 am: **Mosaicking of astronomical images with MOPEX**, D. Makovoz, I. Khan, F. J. Masci, California Institute of Technology . [6065-40]
- 11:40 am: **Image processing using parallel GPU units**, K. A. Bjorke, NVIDIA Corp. [6065-41]
- 12:00 pm: **Partial shape similarity of contours is needed for object recognition**, Z. Pizlo, Purdue Univ.; L. J. Latecki, Temple Univ. . [6065-42]

Conference 6066 • Conv. Ctr. Room C4

Tuesday-Wednesday 17-18 January 2006 • Proceedings of SPIE Vol. 6066

Vision Geometry XIV

Conference Chairs: Longin Jan Latecki, Temple Univ.; David M. Mount, Univ. of Maryland/College Park; Angela Y. Wu, American Univ.

Program Committee: Gady Agam, Illinois Institute of Technology; Gilles Bertrand, Groupe ESIEE (France); Atsushi Imiya, Chiba Univ. (Japan); Jack Koplowitz, Clarkson Univ.; Nathan S. Netanyahu, Bar Ilan Univ. (Israel); Peter Veelaert, Hogeschool Gent (Belgium); Xiaodong Wu, Univ. of Iowa

Tuesday 17 January

<p>Plenary Speaker Tues. 8:30 to 9:15 am</p> <p><i>Marriott Ballroom 1-6</i></p> <p>Image Processing: Interconnections</p> <p>Thomas S. Huang, Beckman Institute for Advanced Science and Technology, Univ. of Illinois at Urbana-Champaign</p> <p><i>See p. 7 for details.</i></p>
--

SESSION 1

Conv. Ctr. Room C4 Tues. 9:30 am to 12:00 pm

Shape and Object Recognition I

Chair: Longin Jan Latecki, Temple Univ.

- 9:30 am: **A deformable model with topology analysis and adaptive clustering for boundary detection**, M. Allili, Bishop's Univ. (Canada); B. Yang, Univ. de Sherbrooke (Canada); L. Bentabet, Bishop's Univ. (Canada) [6066-01]
- 9:55 am: **Refining road map using active shape model from aerial images**, G. Koutaki, K. Uchimura, Z. Hu, Kumamoto Univ. (Japan) [6066-02]
- Coffee Break 10:20 to 10:45 am
- 10:45 am: **Quantification of line-mura defect level based on multiple characterizing features**, N. K. Park, K. N. Choi, S. I. Yoo, Seoul National Univ. (South Korea) [6066-03]
- 11:10 am: **Model-based shape classification using shape-transformation-invariant descriptors**, S. C. Lee, Univ. of Oklahoma; Y. Wang, E. T. Lee, Univ. of Oklahoma Health Sciences Ctr. [6066-04]
- 11:35 am: **Refinement of axial shape description**, A. N. Skourikhine, Los Alamos National Lab. [6066-05]
- Lunch/Exhibition Break 12:00 to 1:20 pm

SESSION 2

Conv. Ctr. Room C4 Tues. 1:20 to 2:00 pm

Shape and Object Recognition II

Chair: Longin Jan Latecki, Temple Univ.

- 1:20 pm: **Geometry of human vision (Invited Paper, Presentation Only)**, Z. Pizlo, Purdue Univ. [6066-06]

SESSION 3

Conv. Ctr. Room C4 Tues. 2:00 to 3:15 pm

3D Geometry

Chair: Kun Lee, Handong Global Univ. (South Korea)

- 2:00 pm: **Fitting polygonal regions for matching 3D polyhedra**, L. Mukherjee, V. Singh, J. Xu, R. Berezney, SUNY/Univ. at Buffalo [6066-07]
- 2:25 pm: **Hierarchical two view line segment matching using wavelet transform**, F. Mai, Y. Hung, W. Sze, The Univ. of Hong Kong (Hong Kong China) [6066-09]
- 2:50 pm: **A vision-based approach to extracting the tilt angle and altitude of a PTZ camera**, I. Chen, S. Wang, National Chiao Tung Univ. (Taiwan) [6066-10]
- Coffee Break 3:15 to 3:45 pm

SESSION 4

Conv. Ctr. Room C4 Tues. 3:45 to 4:35 pm

Aspects of Vision Geometry

Chair: David M. Mount, Univ. of Maryland/College Park

- 3:45 pm: **Perspex machine V: compilation of C programs**, M. P. Spanner, J. A. D. W. Anderson, The Univ. of Reading (United Kingdom) [6066-12]
- 4:10 pm: **Automatic and robust classification of independent motions in video sequences**, X. An, Zhejiang Univ. (China) [6066-13]

✓ Posters and Demonstrations-Tuesday

Demonstrations 5:30 to 8:30 pm

A symposium-wide demonstration session will be open to attendees 5:30 to 8:30 pm Tuesday evening in Conv. Ctr. Exhibit Hall 1. Demonstrators will provide interactive, hands-on demonstrations of a wide-range of products related to Electronic Imaging.

Posters 5:30 to 7:00 pm

- Posters will be placed on display after 10:00 am in Exhibit Hall 1. A poster session, with authors present at their posters, will be held Tuesday evening, 5:30 to 7:00 pm.*
- ✓ **A three-dimensional shape measurement method: structure light space-time stereo**, X. Li, Shanghai Univ. (China) [6066-28]
- ✓ **Multiview image calibration and rectification for and effective 3D display**, K. Bae, 3R Inc. (South Korea); H. Kang, E. Kim, Kwangwoon Univ. (South Korea) [6066-29]
- ✓ **Perspex machine VI: a graphical user interface to the Perspex machine**, C. J. Kershaw, J. A. D. W. Anderson, The Univ. of Reading (United Kingdom) [6066-30]
- ✓ **Perspex machine VII: the universal Perspex machine**, J. A. D. W. Anderson, The Univ. of Reading (United Kingdom) [6066-31]

Conference 6066 • Conv. Ctr. Room C4

Wednesday 18 January

Plenary Speaker Wed. 8:30 to 9:15 am

Marriott Ballroom 1-6

Computational Imaging Methods for Functional Brain Mapping and Molecular Imaging

Richard Leahy, Univ. of Southern California

See p. 7 for details.

SESSION 5

Conv. Ctr. Room C4 Wed. 9:30 to 11:35 am

Digital Geometry and Topology

Chair: Peter F. Stiller, Texas A&M Univ.

9:30 am: **Discrete circles: an arithmetical approach with non-constant thickness**, C. Fiorio, D. Jamet, J. Toutant, Univ. Montpellier II (France) [6066-14]

9:55 am: **Estimating the analog perimeter of a pre-digitized shape**, S. C. Lee, Univ. of Oklahoma; Y. Wang, E. T. Lee, Univ. of Oklahoma Health Sciences Ctr. [6066-15]

Coffee Break 10:20 to 10:45 am

10:45 am: **Three-dimensional fast exact Euclidean distance (3D-FEED) maps**, T. E. Schouten, H. C. Kuppens, Radboud Univ. Nijmegen (Netherlands); E. L. van den Broek, Vrije Univ. Amsterdam (Netherlands) [6066-17]

11:10 am: **Estimating the surface area and volume of a general 3D shape**, S. C. Lee, Univ. of Oklahoma; Y. Wang, E. T. Lee, Univ. of Oklahoma Health Sciences Ctr. [6066-18]

Lunch/Exhibition Break 11:35 am to 1:20 pm

SESSION 6

Conv. Ctr. Room C4 Wed. 1:20 to 3:25 pm

Image Matching and Registration

Chair: James G. Anderson, The Univ. of Reading (United Kingdom)

1:20 pm: **Dynamic RANSAC**, W. Sze, A. W. Tang, Y. Hung, The Univ. of Hong Kong (Hong Kong China) [6066-19]

1:45 pm: **Singular value decomposition based scale invariant image matching**, W. Sze, A. W. Tang, Y. Hung, The Univ. of Hong Kong (Hong Kong China) [6066-20]

2:10 pm: **Image matching using algebraic topology**, S. Dardar, Univ. de Sherbrooke (Canada); A. Madjid, Bishop's Univ. (Canada); D. Ziou, Univ. de Sherbrooke (Canada) [6066-21]

2:35 pm: **Robustness and statistical analysis of object/image metrics**, P. F. Stiller, Texas A&M Univ. [6066-22]

3:00 pm: **GSIFT: Geometric Scale Invariant Feature Transform for Terrain Data**, Y. Xiao, S. K. Lodha, Univ. of California/Santa Cruz [6066-23]

Coffee Break 3:25 to 3:50 pm

SESSION 7

Conv. Ctr. Room C4 Wed. 3:50 to 5:30 pm

Surface Reconstruction and Visualization

Chair: Samuel C. Lee, Univ. of Oklahoma

3:50 pm: **Reconstruction of quadratic curves in 3D using two or more perspective views: simulation studies**, S. Kumar, N. Sukavanam, R. Balasubramanian, Indian Institute of Technology Roorkee (India) [6066-24]

4:15 pm: **Visualization of volumetric scattered data by using weighted alpha shapes**, J. Paik, K. Lee, Handong Global Univ. (South Korea); O. Gwon, Chonbuk National Univ. (South Korea) [6066-25]

4:40 pm: **POSS: efficient nonlinear optimization for parameterization methods**, F. G. Vadakkumpadan, Y. Tong, Y. Sun, Purdue Univ. [6066-26]

5:05 pm: **Piecewise compression of large mesh**, A. Qin, Zhejiang Univ. (China) and Shanxi Univ. (China); J. Shi, Z. Liu, M. Huang, Zhejiang Univ. (China) [6066-27]

Conference 6067 • Conv. Ctr. Room C3

Wednesday-Thursday 18-19 January 2006 • Proceedings of SPIE Vol. 6067

Document Recognition and Retrieval XIII

Conference Chairs: **Kazem Taghva**, Univ. of Nevada/Las Vegas; **Xiaofan Lin**, Hewlett-Packard Labs.

Program Committee: **Tim L. Andersen**, Boise State Univ.; **Apostolos Antonacopoulos**, Univ. of Salford (United Kingdom); **Elisa H. Barney Smith**, Boise State Univ.; **Brian D. Davison**, Lehigh Univ.; **Xiaoqing Ding**, Tsinghua Univ. (China); **David S. Doermann**, Univ. of Maryland/College Park; **Jianning Hu**, IBM Thomas J. Watson Research Ctr.; **Matthew F. Hurst**, Intelliseek, Inc.; **Hisashi Ikeda**, Hitachi, Ltd. (Japan); **Tapas Kanungo**, IBM Almaden Research Ctr.; **Daniel P. Lopresti**, Lehigh Univ.; **Thomas A. Nartker**, Univ. of Nevada/Las Vegas; **Sargur N. Srihari**, SUNY/Univ. at Buffalo; **George R. Thoma**, National Library of Medicine; **Berrin A. Yanikoglu**, Sabanci Univ. (Turkey)

Wednesday 18 January

Plenary Speaker Wed. 8:30 to 9:15 am
Marriott Ballroom 1-6
Computational Imaging Methods for Functional Brain Mapping and Molecular Imaging
Richard Leahy, Univ. of Southern California
See p. 7 for details.

SESSION 1

Conv. Ctr. Room C3 Wed. 9:30 to 10:30 am

Handwriting Recognition

9:30 am: **Combining one- and two-dimensional signal recognition approaches to off-line signature verification**, S. N. Srihari, SUNY/Univ. at Buffalo [6067-01]
9:50 am: **Spotting words in handwritten Arabic documents**, S. N. Srihari, H. Srinivasan, P. Babu, C. Bhole, SUNY/Univ. at Buffalo [6067-02]
10:10 am: **HCCR by contour-based elastic mesh fuzzy feature**, L. Sun, YanTai Univ. (China) [6067-03]
Coffee Break 10:30 to 11:00 am

SESSION 2

Conv. Ctr. Room C3 Wed. 11:00 to 11:40 am

Invited Paper I

11:00 am: **Human language technology research at DARPA (Invited Paper, Presentation Only)**, J. Olive, Defense Advanced Research Projects Agency [6067-04]
Lunch/Exhibition Break 11:40 am to 1:40 pm

SESSION 3

Conv. Ctr. Room C3 Wed. 1:40 to 3:00 pm

Optical Character Recognition

1:40 pm: **Partitioning of the degradation space for OCR training**, E. H. Barney Smith, T. L. Andersen, Boise State Univ. [6067-05]
2:00 pm: **Match graph generation for symbolic indirect correlation**, D. P. Lopresti, Lehigh Univ.; G. Nagy, A. Joshi, Rensselaer Polytechnic Institute [6067-06]
2:20 pm: **Toward quantifying the amount of style in a dataset**, X. Zhang, S. Andra, Rensselaer Polytechnic Institute [6067-07]
2:40 pm: **Robust feature extraction for character recognition based on binary image**, L. Wang, L. Zhang, Y. Xing, Z. Wang, Nucotech Co. Ltd. (China); H. Gao, Tsinghua Univ. (China) [6067-08]
Coffee Break 3:00 to 3:30 pm

SESSION 4

Conv. Ctr. Room C3 Wed. 3:30 to 5:10 pm

Image Processing

3:30 pm: **DOCLIB: a software library for document processing**, S. R. Jaeger, G. Zhu, D. S. Doermann, Univ. of Maryland/College Park [6067-09]
3:50 pm: **Address block features for image-based automated mail orientation**, M. S. Khan, SRI International and Univ. of California; H. B. Aradhye, SRI International [6067-10]
4:10 pm: **A robust stamp detection framework on degraded documents**, G. Zhu, S. R. Jaeger, D. S. Doermann, Univ. of Maryland/College Park [6067-11]
4:30 pm: **Adaptive pre-OCR cleanup of grayscale document images**, I. Zavorin, E. Borovikov, M. I. Turner, CACI International Inc.; L. Hernandez, Army Research Lab. [6067-12]
4:50 pm: **JBIG2 text image compression based on OCR**, J. Shang, C. Liu, X. Ding, Tsinghua Univ. (China) [6067-13]

Thursday 19 January

SESSION 5

Conv. Ctr. Room C3 Thurs. 8:40 to 10:20 am

Emerging Applications

8:40 am: **Active document versioning: from layout understanding to adjustment**, X. Lin, H. Chao, G. Nelson, E. Durante, Hewlett-Packard Co. [6067-14]
9:00 am: **Graphic design principles for automated document segmentation and understanding**, F. Vega, H. J. Santos-Villalobos, Univ. de Puerto Rico Mayagüez [6067-15]
9:20 am: **A new document authentication method by embedding deformation characters**, X. Wang, X. Ding, H. Liu, C. Liu, Tsinghua Univ. (China) [6067-16]
9:40 am: **CAPTCHA challenge strings: problems and improvements**, J. L. Bentley, C. L. Mallows, Avaya Inc. [6067-17]
10:00 am: **An automatically updateable web publishing solution: taking document sharing and conversion to enterprise level**, F. Rahman, BCL Technologies Inc. [6067-18]
Coffee Break 10:20 to 10:50 am

Conference 6067 • Conv. Ctr. Room C3

SESSION 6

Conv. Ctr. Room C3 Thurs. 10:50 to 11:50 am

Document Retrieval

10:50 am: **Automatic redaction of private information using relational information extraction**, K. Taghva, R. Beckley, J. S. Coombs, J. Borsack, R. Pereda, T. A. Nartker, Univ. of Nevada/Las Vegas [6067-19]

11:10 am: **Document clustering: applications in a collaborative digital library**, F. Rahman, BCL Technologies Inc. [6067-20]

11:30 am: **Author name recognition in degraded journal images**, A. de Bodard de la Jacopiere, L. Likforman, École Nationale Supérieure des Télécommunications (France) [6067-21]

Lunch Break 11:50 am to 1:40 pm

SESSION 7

Conv. Ctr. Room C3 Thurs. 1:40 to 2:20 pm

Invited Paper II

1:40 pm: **Complex document information processing: prototype, test collection, and evaluation (*Invited Paper*)**, G. Agam, Illinois Institute of Technology; S. Argamon, Illinois Institute of Technology; O. Frieder, D. Grossman, D. Lewis, Illinois Institute of Technology [6067-23]

SESSION 8

Conv. Ctr. Room C3 Thurs. 2:20 to 3:40 pm

Learning and Classification

2:20 pm: **Comparative evaluation of different classifiers for robust distorted character recognition**, B. As-Sadhan, Z. Al Bawab, A. El Seed, M. Noamany, Carnegie Mellon Univ. [6067-24]

2:40 pm: **Style consistent nearest neighbor classifier**, S. Andra, X. Zhang, Rensselaer Polytechnic Institute [6067-25]

3:00 pm: **Optimally combining a cascade of classifiers**, K. H. Chellapilla, M. M. Shilman, P. Simard, Microsoft Corp. [6067-26]

3:20 pm: **Versatile document image content extraction**, H. S. Baird, M. A. Moll, Lehigh Univ. [6067-27]

Conference 6068 • Conv. Ctr. Room A6

Wednesday-Thursday 18-19 January 2006 • Proceedings of SPIE Vol. 6068

Sensors, Cameras, and Systems for Scientific/Industrial Applications VIII

Conference Chair: **Morley M. Blouke**, Ball Aerospace & Technologies Corp.

Program Committee: **Erik Bodegom**, Portland State Univ. and Technische Univ. Delft (Netherlands); **Robin M. Dawson**, Sarnoff Corp.; **Terrence S. Lomheim**, The Aerospace Corp.; **Gloria G. Putnam**, Eastman Kodak Co.; **Alice L. Reinheimer**, e2v Technologies, Inc.; **Nobukazu Teranishi**, Matsushita Electric Industrial Co., Ltd. (Japan); **Orly Yadid-Pecht**, Univ. of Calgary (Canada)

Tuesday 17 January

Plenary Speaker **Tues. 8:30 to 9:15 am**

Marriott Ballroom 1-6

Image Processing: Interconnections

Thomas S. Huang, Beckman Institute for Advanced Science and Technology, Univ. of Illinois at Urbana-Champaign

See p. 7 for details.

✓ Posters and Demonstrations-Tuesday

Demonstrations **5:30 to 8:30 pm**

A symposium-wide demonstration session will be open to attendees 5:30 to 8:30 pm Tuesday evening in Conv. Ctr. Exhibit Hall 1.

Demonstrators will provide interactive, hands-on demonstrations of a wide-range of products related to Electronic Imaging.

Posters **5:30 to 7:00 pm**

Posters will be placed on display after 10:00 am in Exhibit Hall 1. A poster session, with authors present at their posters, will be held Tuesday evening, 5:30 to 7:00 pm.

✓ **An improved method for calculating the MTF of an optical system**, A. Walter, S. Lashansky, Israel Air Force (Israel) [6068-30]

Wednesday 18 January

Plenary Speaker **Wed. 8:30 to 9:15 am**

Marriott Ballroom 1-6

Computational Imaging Methods for Functional Brain Mapping and Molecular Imaging

Richard Leahy, Univ. of Southern California

See p. 7 for details.

SESSION 1

Conv. Ctr. Room A6 **Wed. 9:30 to 11:40 am**

CMOS Devices

9:30 am: **In vitro and in vivo on-chip biofluorescence imaging using a CMOS image sensor**, D. C. Ng, M. Matsuo, T. Tokuda, K. Kagawa, M. Nunoshita, J. Ohta, Nara Institute of Science and Technology (Japan) [6068-01]

9:50 am: **An optical and potential dual-image CMOS sensor for bioscientific applications**, T. Tokuda, A. Yamamoto, K. Kagawa, M. Nunoshita, J. Ohta, Nara Institute of Science and Technology (Japan) [6068-02]

Coffee Break 10:10 to 10:40 am

10:40 am: **A CMOS active pixel sensor for retinal stimulation**, M. L. Prydderch, M. J. French, Rutherford Appleton Lab. (United Kingdom); K. Mathieson, C. Adams, D. Gunning, J. Laudanski, J. D. Morrison, A. R. Moodie, J. Sinclair, Univ. of Glasgow (United Kingdom) [6068-03]

11:00 am: **Noise analysis of fault tolerant active pixel sensors with and without defects**, M. L. La Haye, C. G. Jung, M. H. Izadi, G. H. Chapman, K. S. Karim, Simon Fraser Univ. (Canada) [6068-04]

11:20 am: **A model for dark current characterization and simulation**, R. L. Baer, Agilent Technologies [6068-05]

Lunch/Exhibition Break 11:40 am to 1:30 pm

SESSION 2

Conv. Ctr. Room A6 **Wed. 1:30 to 4:20 pm**

CMOS Devices and Applications

1:30 pm: **An image sensor with on-die diffractive optics in 0.18-micron bulk CMOS**, C. J. Thomas, R. I. Hornsey, York Univ. (Canada) . . [6068-06]

1:50 pm: **CMOS long linear array for space application**, G. Lepage, Cypress Semiconductor Corp. (Belgium); D. G. Dantes, Alcatel Alenia Space (France) [6068-08]

2:10 pm: **Experimental single-chip color HDTV image acquisition system with 8-Mpixel CMOS image sensor**, H. Shimamoto, T. Yamashita, R. Funatsu, K. Mitani, Y. Nojiri, NHK Science & Technical Research Labs. (Japan) [6068-09]

2:30 pm: **High-sensitivity 2.5- μ m pixel CMOS image sensor realized using Cu interconnect layers**, K. Tatani, Y. Enomoto, A. Yamamoto, T. Goto, H. Abe, T. Hirayama, Sony Corp. (Japan) . . [6068-11]

2:50 pm: **CMOS image sensor overlaid with organic photoelectric conversion layers and the proposal of stack type solid-state imaging devices**, S. Takada, M. Inuiya, Y. Araki, Fuji Photo Film Co., Ltd. (Japan) [6068-12]

Coffee Break 3:10 to 3:40 pm

3:40 pm: **An ultrawide dynamic-range CMOS image sensor with a linear response**, J. H. Park, M. Mase, S. Kawahito, Shizuoka Univ. (Japan); M. Sasaki, Sendai National College of Technology (Japan); Y. Wakamori, Yamaha Corp. (Japan); Y. Ohta, Hamamatsu Corp. (Japan) [6068-13]

4:00 pm: **A pulse-frequency-modulation vision chip using a capacitive feedback reset with in-pixel 1-bit image processors**, K. Kagawa, S. Yamamoto, T. Furumiya, T. Tokuda, M. Nunoshita, J. Ohta, Nara Institute of Science and Technology (Japan) [6068-14]

Conference 6068 • Conv. Ctr. Room A6

Thursday 19 January

SESSION 3

Conv. Ctr. Room A6 Thurs. 9:00 to 11:50 am

Novel Devices and CCDs

9:00 am: **Photon counting imaging: the DigitalAPD**, S. Bellis, R. Wilcock, J. C. Jackson, SensL Technologies Ltd. (Ireland) [6068-15]

9:20 am: **Quantitative and qualitative performance comparison of a biomimetic vision sensor with commercial CCD camera sensors**, R. S. Prabhakara, C. H. G. Wright, S. F. Barrett, W. M. Harman, Univ. of Wyoming [6068-16]

9:40 am: **Quantum efficiency characterization of CCD's part 1: the quantum efficiency machine**, D. E. Groom, C. J. Bebek, M. H. Fabricius, A. Karcher, J. Steckert, Lawrence Berkeley National Lab. [6068-35]

10:00 am: **Quantum efficiency characterization of back-illuminated CCD's part 2: reflectivity measurements**, M. H. Fabricius, Lawrence Berkeley National Lab. [6068-36]

Coffee Break 10:20 to 10:50 am

10:50 am: **28-M CCD imager with RGB compatible binning feature for professional applications**, I. Peters, C. Draijer, F. Polderdijk, L. Mcessen, B. G. M. Dillen, W. Klaassens, J. T. Bosiers, DALSA Professional Imaging (Netherlands) [6068-34]

11:10 am: **Large area devices at Semiconductor Technology Associates, Inc.**, K. L. Boggs, R. A. Bredthauer, Semiconductor Technology Associates Inc. [6068-17]

11:30 am: **Development of the orthogonal-transfer array**, B. E. Burke, MIT Lincoln Lab.; J. L. Tonry, Univ. of Hawai'i/West O'ahu; M. J. Cooper, MIT Lincoln Lab.; P. M. Onaka, Univ. of Hawai'i/West O'ahu; D. J. Young, A. H. Loomis, MIT Lincoln Lab. [6068-18]

Lunch Break 11:50 am to 1:30 pm

SESSION 4

Conv. Ctr. Room A6 Thurs. 1:30 to 4:40 pm

Applications

1:30 pm: **Toward 1-mm depth precision with a solid state full-field range imaging system**, A. A. Dorrington, Univ. of Waikato (New Zealand); D. A. Carnegie, Victoria Univ. of Wellington (New Zealand); M. J. Cree, Univ. of Waikato (New Zealand) [6068-22]

1:50 pm: **An ultrafast phase modulator for 3D imaging**, J. Y. Cheng, Northeastern Univ.; Q. Chen, Boston Applied Technologies Inc. . [6068-23]

2:10 pm: **Classification of luminaire color using CCDs with application to airport lighting**, K. R. McMenemy, J. H. Niblock, Queen's Univ. Belfast (United Kingdom) [6068-24]

2:30 pm: **Lateral chromatic aberration correction system for ultrahigh-definition color video camera**, T. Yamashita, H. Shimamoto, R. Funatsu, K. Mitani, Y. Nojiri, NHK Science & Technical Research Labs. (Japan) [6068-25]

2:50 pm: **A new direct detection camera system for electron microscopy**, N. Xuong, L. Jin, A. Milazzo, P. C. Leblanc, F. Duttweiler, J. C. Bouwer, S. Peltier, M. H. Ellisman, Univ. of California/San Diego; S. Li, S. Kleinfelder, Univ. of California/Irvine [6068-26]

Coffee Break 3:10 to 3:40 pm

3:40 pm: **A novel image processing system that autonomously monitors lighting patterns with application to airport lighting**, J. H. Niblock, K. R. McMenemy, G. Irwin, Queen's Univ. Belfast (United Kingdom) [6068-27]

4:00 pm: **Wafer-scale UV embossing of aspheric lenses in phone-camera module**, D. Shin, H. Jeong, S. Kim, S. C. Lee, Y. Jin, J. E. Noh, H. R. Oh, K. Lee, SAMSUNG Electro-Mechanics Co., Ltd. (South Korea) [6068-28]

4:20 pm: **Colony optical image acquisition system**, W. Wang, Chongqing Univ. of Posts and Telecommunications (China) [6068-29]

Conference 6069 • Conv. Ctr. Room A6

Monday-Tuesday 16-17 January 2006 • Proceedings of SPIE Vol. 6069

Digital Photography II

Conference Chairs: **Nitin Sampat**, Rochester Institute of Technology; **Jeffrey M. DiCarlo**, Hewlett-Packard Labs.; **Russel A. Martin**, Foveon USA

Program Committee: **Eiji Atsumi**, Nokia Japan Co., Ltd. (Japan); **Ted J. Cooper**, Sony Electronics Inc.; **Michael A. Kriss**, Sharp Labs. of America; **Jingqiang Li**, Qualcomm, Inc.; **Ricardo J. Motta**, PIXIM, Inc.; **Gloria G. Putnam**, Eastman Kodak Co.; **John R. Reinert Nash**, Lifetouch, Inc.; **Brian G. Rodricks**, Micron Technology, Inc.; **Sabine E. Süsstrunk**, École Polytechnique Fédérale de Lausanne (Switzerland)

Monday 16 January

SESSION 1

Conv. Ctr. Room A6 **Mon. 8:30 to 10:20 am**

Sensor Design

Chair: **Russel A. Martin**, Foveon, Inc.

8:30 am: **A brief history of 'pixel' (Invited Paper)**, R. F. Lyon, Foveon, Inc. [6069-01]

9:00 am: **31 Mp and 39 Mp full-frame CCD image sensors with improved charge capacity and angle response**, E. J. Meisenzahl, E. K. Banghart, D. N. Nichols, J. P. Shepherd, E. G. Stevens, K. Y. Wong, Eastman Kodak Co. [6069-02]

9:20 am: **Improving low-light CMOS performance with four-transistor four-shared pixel architecture and charge-domain binning**, F. Chu, R. M. Guidash, J. Compton, S. Coppola, W. Hintz, Eastman Kodak Co. [6069-03]

9:40 am: **Optical interaction of space and wavelength in high-resolution digital imagers**, B. G. Rodricks, K. Venkataraman, Micron Technology, Inc.; P. B. Catrysse, B. A. Wandell, Stanford Univ. [6069-04]

10:00 am: **Image recovery for a direct color imaging approach using a color filter array**, T. Saito, T. Komatsu, Kanagawa Univ. (Japan) [6069-05]

Coffee Break 10:20 to 10:50 am

SESSION 2

Conv. Ctr. Room A6 **Mon. 10:50 am to 12:10 pm**

Demosaicing

Chair: **Michael A. Kriss**, Consultant

10:50 am: **Demosaicing: heterogeneity projection hard-decision adaptive interpolation using spectral-spatial correlation**, C. Tsai, K. Song, National Chiao Tung Univ. (Taiwan) [6069-06]

11:10 am: **Iterative asymmetric average interpolation for color demosaicing of single-sensor digital camera data**, Y. Takahashi, H. Kikuchi, S. Muramatsu, Niigata Univ. (Japan); N. Mizutani, Kodak Japan Ltd. (Japan) [6069-07]

11:30 am: **Spatially adaptive superresolution sharpening-demosaicking for a single solid state color image sensor**, T. Saito, T. Komatsu, Kanagawa Univ. (Japan) [6069-08]

11:50 am: **Generic MSFA mosaicing and demosaicing for multispectral cameras**, L. Miao, H. Qi, The Univ. of Tennessee; R. Ramanath, North Carolina State Univ. [6069-09]

Lunch Break 12:10 to 1:40 pm

SESSION 3

Conv. Ctr. Room A6 **Mon. 1:40 to 3:00 pm**

Auto Exposure, Focus, and White Balance

Chair: **Jeffrey M. DiCarlo**, Hewlett-Packard Labs.

1:40 pm: **Dynamic focus window selection using a statistical color model**, Y. Tian, Univ. of California/Berkeley [6069-10]

2:00 pm: **Combinational AE-AF system with fuzzy climbing search servo**, C. Chen, C. Tseng, C. Hung, I. Yin, S. Wang, National Chiao Tung Univ. (Taiwan) [6069-11]

2:20 pm: **Multidomain pixel analysis for illuminant estimation**, F. Gasparini, R. Schettini, Univ. degli Studi di Milano-Bicocca (Italy); F. Naccari, A. Bruna, STMicroelectronics (Italy) [6069-12]

2:40 pm: **Computational inexpensive two-step auto white balance method**, S. R. Goma, M. Aleksic, ATI Technology (Canada) [6069-13]

Coffee Break 3:00 to 3:30 pm

SESSION 4

Conv. Ctr. Room A6 **Mon. 3:30 to 4:50 pm**

Image Enhancement

Chair: **Brian G. Rodricks**, Micron Technology, Inc.

3:30 pm: **An effective image enhancement filtering for noisy image sequences**, H. Lee, D. Park, S. Lee, C. Kim, SAMSUNG Advanced Institute of Technology (South Korea) [6069-14]

3:50 pm: **Novel bilateral filter approach: image noise reduction with sharpening**, M. Aleksic, M. Smirnov, S. R. Goma, ATI Technology (Canada) [6069-15]

4:10 pm: **Digital photograph stitching with optimized matching of gradient and curvature**, S. T. Suen, E. Y. Lam, K. K. Wong, The Univ. of Hong Kong (Hong Kong China) [6069-16]

4:30 pm: **Compensation of nonuniform flash illumination in group portrait photography**, J. H. Kim, Pukyong National Univ. (South Korea); B. A. Barsky, Univ. of California/Berkeley [6069-17]

SESSION 5

Conv. Ctr. Room A6 **Mon. 4:50 to 5:30 pm**

Imaging Systems

Chair: **John R. Reinert Nash**, Lifetouch, Inc.

4:50 pm: **A robotic system for digital photography**, L. W. MacDonald, London College of Communication [6069-18]

5:10 pm: **Source camera identification using footprints from JPEG compression and lens aberration**, K. S. Choi, E. Y. Lam, K. K. Wong, The Univ. of Hong Kong (Hong Kong China) [6069-19]

Conference 6069 • Conv. Ctr. Room A6

Tuesday 17 January

Plenary Speaker **Tues. 8:30 to 9:15 am**
Marriott Ballroom 1-6
Image Processing: Interconnections
Thomas S. Huang, Beckman Institute for Advanced Science and
Technology, Univ. of Illinois at Urbana-Champaign
See p. 7 for details.

SESSION 6

Conv. Ctr. Room A6 **Tues. 9:30 to 10:20 am**

Camera Evaluation I

Chair: Nitin Sampat, Rochester Institute of Technology

9:30 am: **Evaluating digital cameras (Invited Paper)**, D. Wueller, Image
Engineering (Germany) [6069-20]

10:00 am: **The Imatest program: comparing cameras with different
amounts of sharpening**, N. L. Koren, Imatest LLC [6069-21]

Coffee Break 10:20 to 10:50 am

SESSION 7

Conv. Ctr. Room A6 **Tues. 10:50 am to 12:10 pm**

Camera Evaluation II

Chair: Jingqiang Li, Rochester Institute of Technology

10:50 am: **Resolution for color photography**, P. M. Hubel, Foveon,
Inc. [6069-22]

11:10 am: **Resolution and light sensitivity tradeoff with pixel size**, J. E.
Farrell, Stanford Univ.; F. Xiao, Agilent Technologies; S. Kavusi, Stanford
Univ. [6069-23]

11:30 am: **Characterization of noise in digital photographs for image
processing**, S. Lim, Hewlett-Packard Co. [6069-24]

11:50 am: **Proposal for a standard procedure to test mobile phone
cameras**, D. Wueller, Image Engineering (Germany) [6069-25]

Demonstration Session

A symposium-wide demonstration session will be open to attendees

5:30 to 8:30 pm Tuesday evening in Conv. Ctr. Exhibit Hall 1.

*Demonstrators will provide interactive, hands-on demonstrations of a
wide-range of products related to Electronic Imaging.*

Conference 6070 • Conv. Ctr. Room C3

Monday-Tuesday 16-17 January 2006 • Proceedings of SPIE Vol. 6070

Machine Vision Applications in Industrial Inspection XIV

Conference Chairs: **Fabrice Meriaudeau**, Univ. de Bourgogne (France); **Kurt S. Niel**, Fachhochschule Wels (Austria)

Program Committee: **Pierrick T. Bourgeat**, BioMedA Lab. (Australia); **Luciano da Fontoura Costa**, Univ. de São Paulo (Brazil); **Marc M. Ellenrieder**, Daimler Chrysler AG (Germany); **Steven P. Floeder**, 3M Co.; **David Fofi**, Univ. de Bourgogne (France); **Ralph M. Ford**, The Pennsylvania State Univ.; **Edmund Y. Lam**, The Univ. of Hong Kong (Hong Kong China); **Katia Lebart**, Heriot-Watt Univ. (United Kingdom); **Dinesh Nair**, National Instruments; **Paul L. O'Leary**, Montan Univ. Leoben (Austria); **Jeffery R. Price**, Oak Ridge National Lab.; **A. Ravishankar Rao**, IBM Thomas J. Watson Research Ctr.; **Joaquim Salvi**, Univ. de Girona (Spain); **Hamed Sari-Sarraf**, Texas Tech Univ.; **Christoph Stiller**, Univ. Karlsruhe (Germany); **Kenneth W. Tobin, Jr.**, Oak Ridge National Lab.; **Yvon Voisin**, Univ. de Bourgogne (France)

Monday 16 January

SESSION 1

Conv. Ctr. Room C3 Mon. 8:40 to 10:00 am

Industrial Applications I

Chair: **Fabrice Meriaudeau**, Univ. de Bourgogne (France)

8:40 am: **Optical servoing for industrial surface machining**, N. Koller, Hotvision Research GmbH (Austria); R. Ofner, P. L. O'Leary, Montan Univ. Leoben (Austria); E. Fauster, Hotvision Research GmbH (Austria) [6070-01]

9:00 am: **Statistical learning with imbalanced training set in a machine vision application: improve the false alarm rate and sensitivity simultaneously**, J. Q. Li, Agilent Technologies, Inc. [6070-02]

9:20 am: **Boundary detection of projected fringes for surface of inhomogeneous reflectance**, J. Cheng, R. C. Chung, The Chinese Univ. of Hong Kong (Hong Kong China); E. Y. Lam, The Univ. of Hong Kong (Hong Kong China); K. S. M. Fung, F. Wang, W. H. Leung, ASM Assembly Automation Ltd. (Hong Kong China) [6070-03]

9:40 am: **Height inspection of wafer bumps without explicit 3D reconstruction**, M. Dong, R. C. Chung, Y. Zhao, The Chinese Univ. of Hong Kong (Hong Kong China); E. Y. Lam, The Univ. of Hong Kong (Hong Kong China) [6070-04]

Coffee Break 10:00 to 10:30 am

SESSION 2

Conv. Ctr. Room C3 Mon. 10:30 am to 12:10 pm

Multispectral Imaging

Chair: **Kurt S. Niel**, Fachhochschule Wels (Austria)

10:30 am: **Fast recognition method for metallic topographies by the "Three-Color Selective Stereo Gradient Method" (Three-Color SSGM)**, M. Hossfeld, Technische Univ. Hamburg-Harburg (Germany); M. Adameck, Hella KGaA Hueck & Co. (Germany); M. Eich, Technische Univ. Hamburg-Harburg (Germany) [6070-05]

10:50 am: **Robustness of texture parameters for color texture analysis**, A. Marin, A. Roman, Univ. de Bourgogne (France); D. R. Connah, J. Y. Hardeberg, Gjøvik Univ. College (Norway); P. Gouton, Univ. de Bourgogne (France) [6070-06]

11:10 am: **Real-time multispectral imaging application for poultry safety inspection**, B. Park, K. C. Lawrence, W. R. Windham, M. P. Snead, U.S. Dept. of Agriculture [6070-07]

11:30 am: **Flushing analysis by machine vision and fuzzy logic at molten steel for the automation process**, C. Pfob, K. S. Niel, Fachhochschule Wels (Austria); R. Rössler, voestalpine Mechatronics GmbH (Austria) [6070-08]

11:50 am: **Color influence in accuracy of 3D scanner based on structured light**, S. Voisin, The Univ. of Tennessee and Univ. de Bourgogne (France); D. L. Page, The Univ. of Tennessee; S. Fough, F. Truchetet, Univ. de Bourgogne (France); M. A. Abidi, The Univ. of Tennessee [6070-09]

Lunch Break 12:10 to 1:40 pm

SESSION 3

Conv. Ctr. Room C3 Mon. 1:40 to 2:40 pm

3D Applications I

Chair: **Jeffery R. Price**, Oak Ridge National Lab.

1:40 pm: **Novel view synthesis for projective texture mapping on real 3D objects**, T. Molinier, D. Fofi, P. Gorria, Univ. de Bourgogne (France) [6070-10]

2:00 pm: **3D translucent object reconstruction from artificial vision**, F. Truchetet, Univ. de Bourgogne (France) [6070-11]

2:20 pm: **Real-time 3D wood panel surface measurement using laser triangulation and low-cost hardware**, H. Ramoser, L. Cambrini, H. Rötzer, Advanced Computer Vision (Austria) [6070-12]

SESSION 4

Conv. Ctr. Room C3 Mon. 2:40 to 4:50 pm

Industrial Applications II

Chair: **Kurt S. Niel**, Fachhochschule Wels (Austria)

2:40 pm: **Aerial platform attitude measurement by artificial vision**, F. Truchetet, O. Aubret, P. Gorria, O. Lalignat, Univ. de Bourgogne (France) [6070-14]

3:00 pm: **A new algorithm for real-time multistage image thresholding**, S. H. Lin, R. Giesen, D. Nair, National Instruments [6070-15]

Coffee Break 3:20 to 3:50 pm

3:50 pm: **Simultaneous photometric correction and defect detection in semiconductor manufacturing**, Y. Shen, E. Y. Lam, The Univ. of Hong Kong (Hong Kong China) [6070-16]

4:10 pm: **Automatic mura detection system for liquid crystal display panels**, L. Fang, H. Chen, I. Yin, S. Wang, C. Wen, C. Kuo, National Chiao Tung Univ. (Taiwan) [6070-17]

4:30 pm: **New developments in image-based characterization of coated particle nuclear fuel**, J. R. Price, D. Aykac, J. D. Hunn, A. K. Kercher, R. N. Morris, Oak Ridge National Lab. [6070-18]

Conference 6070 • Conv. Ctr. Room C3

Tuesday 17 January

Plenary Speaker **Tues. 8:30 to 9:15 am**

Marriott Ballroom 1-6

Image Processing: Interconnections

Thomas S. Huang, Beckman Institute for Advanced Science and Technology, Univ. of Illinois at Urbana-Champaign

See p. 7 for details.

SESSION 5

Conv. Ctr. Room C3 **Tues. 9:30 to 11:40 am**

Multiresolution and Mathematical Fitting

Chair: Fabrice Meriaudeau, Univ. de Bourgogne (France)

9:30 am: **Real-time detection of elliptic shapes for automated object recognition and object tracking**, C. Teutsch, D. Berndt, E. Trostmann, M. Weber, Fraunhofer-Institut für Fabrikbetrieb und -automatisierung (Germany) [6070-19]

9:50 am: **Discrete circles measurement for industrial inspection**, F. Mairesse, T. M. Sliwa, S. Binczak, Y. Voisin, Univ. de Bourgogne (France) [6070-20]

Coffee Break 10:10 to 10:40 am

10:40 am: **Twin and scratch detection and removal in micrograph images of Inconel 718**, G. Jakob, A. Rinnohofer, Joanneum Research (Austria); H. Bischof, Technische Univ. Graz (Austria); W. Benesova, Joanneum Research (Austria) [6070-21]

11:00 am: **Tracking fluorescent spots in wide-field microscopy images**, L. A. Muresan, B. Heise, E. P. Klement, Johannes Kepler Univ. Linz (Austria) [6070-22]

11:20 am: **Development of method based on Hough transform or Gabor filtering to discriminate crop and weeds in agronomic image**, J. Bossu, C. Gee, J. Guillemin, Etablissement National d'Enseignement Supérieur Agronomique de Dijon (France); F. Truchetet, Univ. de Bourgogne (France) [6070-23]

SESSION 6

Conv. Ctr. Room C3 **Tues. 11:40 am to 12:20 pm**

3D Applications II

Chairs: Fabrice Meriaudeau, Univ. de Bourgogne (France); Kurt S. Niel, Fachhochschule Wels (Austria)

11:40 am: **A refined range image registration technique applied to multistripe laser 3D scanner**, C. Matabosch, J. Salvi, Univ. de Girona (Spain); D. Fofi, F. Meriaudeau, Univ. de Bourgogne (France) ... [6070-24]

12:00 pm: **Surface orientation recovery of specular microsurface via binary pattern projection**, Z. Song, R. C. Chung, J. Cheng, The Chinese Univ. of Hong Kong (Hong Kong China); E. Y. Lam, The Univ. of Hong Kong (Hong Kong China) [6070-25]

✓ Posters and Demonstrations-Tuesday

Demonstrations **5:30 to 8:30 pm**

A symposium-wide demonstration session will be open to attendees 5:30 to 8:30 pm Tuesday evening in Conv. Ctr. Exhibit Hall 1.

Demonstrators will provide interactive, hands-on demonstrations of a wide-range of products related to Electronic Imaging.

Posters **5:30 to 7:00 pm**

Posters will be placed on display after 10:00 am in Exhibit Hall 1. A poster session, with authors present at their posters, will be held Tuesday evening, 5:30 to 7:00 pm.

✓ **Constructing a simple parametric model of shoulder from medical images**, H. Atmani, F. Mérienne, École Nationale Supérieure d'Arts et Métiers (France); D. Fofi, P. Trouilloud, Univ. de Bourgogne (France) [6070-26]

✓ **A study of automatic monitoring and measuring vehicles by using image analysis**, W. Wang, Chongqing Univ. of Posts and Telecommunications (China) [6070-27]

✓ **An active contour algorithm for detecting the circular features in a PCB x-ray image**, Y. Chen, C. Wu, W. Hu, Yuan Ze Univ. (Taiwan) [6070-28]

✓ **Human vision based detection of nonuniform brightness on LCD panels**, J. H. Kim, Pukyong National Univ.; B. A. Barsky, Univ. of California/Berkeley [6070-30]

✓ **Optimized texture classification by using hierarchical complex networks**, T. Chalumeau, Univ. de Bourgogne (France); L. F. da Fontoura Costa, Univ. de São Paulo (Brazil); F. Meriaudeau, O. Laligant, Univ. de Bourgogne (France) [6070-31]

Conference 6071 • Conv. Ctr. Room C1

Wednesday-Thursday 18-19 January 2006 • Proceedings of SPIE Vol. 6071

Multimedia Computing and Networking 2006

Conference Chairs: **Surendar Chandra**, Univ. of Notre Dame; **Carsten Griwodz**, Univ. of Oslo (Norway)

Program Committee: **Tarek F. Abdelzaher**, Univ. of Virginia; **Sarita V. Adve**, Univ. of Illinois at Urbana-Champaign; **Scott A. Brandt**, Univ. of California/Santa Cruz; **David H. Du**, Univ. of Minnesota; **Wu-chi Feng**, Portland State Univ.; **Pascal Frossard**, École Polytechnique Fédérale de Lausanne (Switzerland); **Pål Halvorsen**, Simula Research Lab. (Norway); **Baochun Li**, Univ. of Toronto (Canada); **Ian Marsh**, Swedish Computer Science Institute (Sweden); **Andreas U. Mauthe**, Lancaster Univ. (United Kingdom); **Ketan D. Mayer-Patel**, The Univ. of North Carolina at Chapel Hill; **Klara Nahrstedt**, Univ. of Illinois at Urbana-Champaign; **Wei-Tsang Ooi**, National Univ. of Singapore (Singapore); **Ragunathan Rajkumar**, Carnegie Mellon Univ.; **Karsten Schwan**, Georgia Institute of Technology; **Tajana Simunic-Rosing**, Univ. of California/ San Diego; **Ralf Steinmetz**, Technische Univ. Darmstadt (Germany); **Nalini Venkatasubramanian**, Univ. of California/ Irvine; **Lars Wolf**, Technische Univ. Braunschweig (Germany); **Dongyan Xu**, Purdue Univ.; **Wanghong Yuan**, DoCoMo Communications Labs. USA, Inc.; **Roger Zimmermann**, Univ. of Southern California; **Michael Zink**, Univ. of Massachusetts/Amherst

Wednesday 18 January

Plenary Speaker Wed. 8:30 to 9:15 am
Marriott Ballroom 1-6
Computational Imaging Methods for Functional Brain Mapping and Molecular Imaging
Richard Leahy, Univ. of Southern California
See p. 7 for details.

SESSION 1

Conv. Ctr. Room C1 Wed. 9:30 am to 12:30 pm

Application-dependent Transfer

9:30 am: **The effects of frame rate and resolution on users playing first person shooter games**, M. Claypool, Worcester Polytechnic Institute; K. Claypool, F. Damaa, Univ. of Massachusetts/Lowell [6071-01]

10:00 am: **Real-time 3D video compression for tele-immersive environments**, Z. Yang, Y. Cui, Z. Anwar, R. Bocchino, N. Kiyandlar, K. Nahrstedt, R. H. Campbell, Univ. of Illinois at Urbana-Champaign; W. J. Yurcik, National Ctr. for Supercomputing Applications [6071-02]

Coffee Break 10:30 to 11:00 am

11:00 am: **An integrated visual approach for music indexing and dynamic playlist composition**, M. Crampes, S. Ranwez, Ecole des Mines d'Alès (France); F. Velickovski, C. Mooney, Univ. of New South Wales (Australia); N. Mille, Netia, Inc. (France) [6071-03]

11:30 am: **Efficient rate-distortion optimized media streaming for tree-reducible packet dependencies**, M. Röder, Univ. of Konstanz (Germany); J. Cardinal, Univ. Libre de Bruxelles (Belgium); R. Hamzaoui, Univ. of Konstanz (Germany) [6071-04]

12:00 pm: **Popular song and lyrics synchronization and its application to music information retrieval**, K. Chen, S. Gao, Y. Zhu, Q. Sun, Institute for Infocomm Research (Singapore) [6071-05]

Lunch/Exhibition Break 12:30 to 2:00 pm

SESSION 2

Conv. Ctr. Room C1 Wed. 2:00 to 4:30 pm

Streaming

2:00 pm: **MMS: a multihome-aware media streaming system**, A. Habib, Siemens Technology to Business Ctr.; J. Chuang, Univ. of California/Berkeley [6071-06]

2:30 pm: **Streamline: a scheduling heuristic for streaming applications on the grid**, B. Agarwalla, N. Ahmed, D. Hilley, U. Ramachandran, Georgia Institute of Technology [6071-07]

Coffee Break 3:00 to 3:30 pm

3:30 pm: **A novel unbalanced multiple description coder for robust video transmission over ad hoc wireless networks**, F. Huang, L. Sun, Y. Zhong, Tsinghua Univ. (China) [6071-08]

4:00 pm: **A transform for network calculus and its application to multimedia networking**, K. Pandit, Technische Univ. Darmstadt (Germany); J. Schmitt, C. Kirchner, Univ. Kaiserslautern (Germany); R. Steinmetz, Technische Univ. Darmstadt (Germany) [6071-09]

Panel Discussion 4:30 to 5:30 pm
Multimedia Sensors: Technological and Societal Challenges
Chair: Roger Zimmermann, Univ. of Southern California

Thursday 19 January

SESSION 3

Conv. Ctr. Room C1 Thurs. 8:30 to 10:30 am

Distribution

8:30 am: **A method to deliver multi-object content in a ubiquitous environment**, T. Mori, M. Katsumoto, National Institute of Information and Communications Technology (Japan) [6071-10]

9:00 am: **Correlation-aware multimedia content distribution in overlay networks**, Y. Zhu, B. Li, Univ. of Toronto (Canada) [6071-11]

9:30 am: **QBIX-G: a transcoding multimedia proxy**, P. Schojer, L. Boeszoermenyi, H. Hellwagner, Univ. Klagenfurt (Austria) [6071-12]

10:00 am: **Preventing DoS attacks in peer-to-peer media streaming systems**, W. G. Conner II, K. Nahrstedt, I. Gupta, Univ. of Illinois at Urbana-Champaign [6071-13]

Coffee Break 10:30 to 11:00 am

SESSION 4

Conv. Ctr. Room C1 Thurs. 11:00 am to 12:00 pm

Keynote Presentation

Keynote

11:00 am: **Playstation and multimedia (Invited Paper, Presentation Only)**, K. Hofrichter, Sony Computer Entertainment America [6071-14]

Lunch Break 12:00 to 1:30 pm

Conference 6071 • Conv. Ctr. Room C1

SESSION 5

Conv. Ctr. Room C1 Thurs. 1:30 to 3:00 pm

Short Papers: Multimedia Systems

1:30 pm: **Investigating a stream synchronization middleware for the NEES MAST system**, J. C. Beyer, S. K. Chirravuri, D. H. Du, Univ. of Minnesota [6071-15]

1:45 pm: **A performance model of effective memory management in HYDRA: a large-scale data stream recording system**, K. Fu, R. Zimmermann, Univ. of Southern California [6071-16]

2:00 pm: **Sender-driven bandwidth differentiation for transmitting multimedia flows over TCP**, J. K. H. Lau, J. Y. B. Lee, The Chinese Univ. of Hong Kong (Hong Kong China) [6071-17]

2:15 pm: **FlexSplit: a workload-aware adaptive load balancing strategy for media clusters**, Q. Zhang, College of William & Mary; L. Cherkasova, Hewlett-Packard Labs.; E. Smirni, College of William & Mary ... [6071-18]

2:30 pm: **Cascades: scalable, flexible, and composable middleware for multimodal sensor networking applications**, J. Huang, W. Feng, N. Bulusu, W. Feng, Portland State Univ. [6071-19]

2:45 pm: **Compression by indexing: an improvement over MPEG-4 body animation parameter compression**, S. Chattopadhyay, S. M. Bhandarkar, K. Li, The Univ. of Georgia [6071-20]

Coffee Break 3:00 to 3:30 pm

SESSION 6

Conv. Ctr. Room C1 Thurs. 3:30 to 5:30 pm

Peer-to-Peer

3:30 pm: **DagStream: locality aware and failure resilient peer-to-peer streaming**, J. Liang, K. Nahrstedt, Univ. of Illinois at Urbana-Champaign [6071-21]

4:00 pm: **Characterizing files in the modern Gnutella network: a measurement study**, S. Zhao, D. Stutzbach, R. Rejaie, Univ. of Oregon [6071-22]

4:30 pm: **Sampling cluster endurance for peer-to-peer based content distribution networks**, V. Darlagiannis, Technische Univ. Darmstadt (Germany); A. U. Mauthe, Lancaster Univ. (United Kingdom); R. Steinmetz, Technische Univ. Darmstadt (Germany) [6071-23]

5:00 pm: **How efficient is BitTorrent?**, G. Wu, T. Chiueh, Stony Brook Univ. [6071-24]

Conference 6072 • Conv. Ctr. Room A5

Monday-Thursday 16-19 January 2006 • Proceedings of SPIE Vol. 6072

Security, Steganography, and Watermarking of Multimedia Contents VIII

Conference Chairs: **Edward J. Delp III**, Purdue Univ.; **Ping Wah Wong**, Nethra Imaging

Program Committee: **Adnan M. Alattar**, Digimarc Corp.; **Mauro Barni**, Univ. degli Studi di Siena (Italy); **Jeffrey A. Bloom**, Thomson Multimedia Corporate Research; **Gordon W. Braudaway**, IBM Corp.; **Ingemar J. Cox**, Univ. College London (United Kingdom); **Jana Dittmann**, Otto-von-Guericke-Univ. Magdeburg (Germany); **Ahmet M. Eskicioglu**, The City Univ. of New York; **Jessica Fridrich**, Binghamton Univ.; **Teddy Furon**, IRISA (France); **Ton Kalker**, Hewlett-Packard Co.; **Martin Kutter**, AlpVision SA (Switzerland); **Reginald L. Lagendijk**, Technische Univ. Delft (Netherlands); **Benoît B. Macq**, Univ. Catholique de Louvain (Belgium); **Bangalore S. Manjunath**, Univ. of California/Santa Barbara; **Nasir D. Memon**, Polytechnic Univ.; **Pierre Moulin**, Univ. of Illinois at Urbana-Champaign; **Fernando Pérez-González**, Univ. de Vigo (Spain); **Gaurav Sharma**, Univ. of Rochester; **Claus Vielhauer**, Otto-von-Guericke-Univ. Magdeburg (Germany); **Sviatoslav V. Voloshynovskiy**, Univ. de Genève (Switzerland); **Min Wu**, Univ. of Maryland/College Park

Monday 16 January

SESSION 1

Conv. Ctr. Room A5 Mon. 8:30 to 11:20 am

Steganography and Steganalysis I

Chair: **Jessica Fridrich**, Binghamton Univ.

- 8:30 am: **New blind steganalysis and its implications**, M. Goljan, J. Fridrich, T. S. Holotyak, Binghamton Univ. [6072-01]
- 8:50 am: **Statistical modeling and steganalysis of DFT-based image steganography**, Y. Wang, P. Moulin, Univ. of Illinois at Urbana-Champaign [6072-02]
- 9:10 am: **Fourth-order structural steganalysis and analysis of cover assumptions**, A. D. Ker, Univ. of Oxford (United Kingdom) [6072-03]
- 9:30 am: **Application of conditional entropy measures to steganalysis**, J. A. Marsh, T. Knapik, E. Lo, SI International; C. D. Heitzenrater, Air Force Research Lab. [6072-04]
- 9:50 am: **Improving steganalysis by fusion techniques: a case study with image-based steganography**, M. Kharrazi, T. H. Sencar, N. D. Memon, Polytechnic Univ. [6072-05]
- Coffee Break 10:10 to 10:40 am
- 10:40 am: **A two-factor error model for quantitative steganalysis**, R. Böhme, Technische Univ. Dresden (Germany); A. D. Ker, Univ. of Oxford (United Kingdom) [6072-06]
- 11:00 am: **Compression-based steganalysis of LSB embedded images**, C. G. Boncelet, Jr., Univ. of Delaware; L. M. Marvel, A. J. Raglin, Army Research Lab. [6072-07]

SESSION 2

Conv. Ctr. Room A5 Mon. 11:20 am to 12:20 pm

Special Session: Natural Language Watermarking

Chairs: **Mercan Topkara**, Purdue Univ.; **Cuneyt M. Taskiran**, Motorola, Inc.

- 11:20 am: **Natural language processing with linguistic information for digital fingerprinting and watermarking**, O. Uzuner, Massachusetts Institute of Technology [6072-08]
- 11:40 am: **Attacks on linguistic steganography systems using text analysis**, C. M. Taskiran, Motorola, Inc.; M. Topkara, E. J. Delp III, Purdue Univ. [6072-09]
- 12:00 pm: **Natural language watermarking: research challenges and applications**, M. Topkara, Purdue Univ.; G. Riccardi, D. Hakkani-Tür, AT&T Labs. Research; M. J. Atallah, Purdue Univ. [6072-10]
- Lunch Break 12:20 to 1:50 pm

SESSION 3

Conv. Ctr. Room A5 Mon. 1:50 to 3:30 pm

Attacks

Chair: **Fernando Pérez-González**, Univ. de Vigo (Spain)

- 1:50 pm: **Scale estimation in two-band filter attacks on QIM watermarks**, J. Wang, Technische Univ. Delft (Netherlands) and Nanjing Univ. (China); I. D. Shterev, R. L. Lagendijk, Technische Univ. Delft (Netherlands) [6072-11]
- 2:10 pm: **High-rate quantization data hiding robust to arbitrary linear filtering attacks**, F. Pérez-González, C. Mosquera, M. Alvarez-Diaz, Univ. de Vigo (Spain); R. L. Lagendijk, Technische Univ. Delft (Netherlands) [6072-12]
- 2:30 pm: **Countermeasure for collusion attacks against digital watermarking**, M. Steinebach, S. Zmudzinski, Fraunhofer-Institut für Integrierte Publikations- und Informationssysteme (Germany) ... [6072-13]
- 2:50 pm: **The blind Newton sensitivity attack**, P. Comesaña Alfaro, L. L. Pérez-Freire, F. Pérez-González, Univ. de Vigo (Spain) [6072-14]
- 3:10 pm: **Achieving non-ambiguity of quantization-based watermarking**, X. Kang, Sun Yat-Sen Univ. (China) and New Jersey Institute of Technology; Y. Shi, New Jersey Institute of Technology; J. Huang, Sun Yat-Sen Univ. (China) [6072-15]
- Coffee Break 3:30 to 4:00 pm

SESSION 4

Conv. Ctr. Room A5 Mon. 4:00 to 5:40 pm

Special Session: Biometrics

Chair: **Claus Vielhauer**, Otto-von-Guericke-Univ. Magdeburg (Germany)

- 4:00 pm: **Reference point detection for improved fingerprint matching**, T. Ignatenko, Technische Univ. Eindhoven (Netherlands); T. Kalker, Hewlett-Packard Co. and Technische Univ. Eindhoven (Netherlands); M. van der Veen, Philips Research Labs. (Netherlands); A. M. Bazen, Univ. Twente (Netherlands) [6072-65]
- 4:20 pm: **Analyzing handwriting biometrics in metadata context**, F. Wolf, T. Scheidat, C. Vielhauer, Otto-von-Guericke-Univ. Magdeburg (Germany) [6072-17]
- 4:40 pm: **3D face recognition by projection-based features**, B. Sankur, H. Dutagaci, Bogaziçi Univ. (Turkey); Y. Yemez, Koç Univ. (Turkey) [6072-18]
- 5:00 pm: **Face biometrics with renewable templates**, M. van der Veen, T. Kevenaar, T. H. Akkermans, G. Schrijen, Philips Research Labs. (Netherlands); F. Zuo, Technische Univ. Eindhoven (Netherlands) [6072-19]
- 5:20 pm: **Safety of templates in biometric person authentication using error-correcting code**, T. Ohki, S. Akatsuka, N. Komatsu, Waseda Univ. (Japan); M. Kasahara, Osaka Gakuin Univ. (Japan) [6072-20]

Conference 6072 • Conv. Ctr. Room A5

Tuesday 17 January

Plenary Speaker Tues. 8:30 to 9:15 am

Marriott Ballroom 1-6

Image Processing: Interconnections

Thomas S. Huang, Beckman Institute for Advanced Science and Technology, Univ. of Illinois at Urbana-Champaign

See p. 7 for details.

SESSION 5

Conv. Ctr. Room A5 Tues. 9:30 to 10:10 am

Audio

Chair: Scott A. Craver, Binghamton Univ.

9:30 am: **On the comparison of audio fingerprints for extracting quality parameters of compressed audio**, P. J. Doets, M. Menor Gisbert, R. L. Lagendijk, Technische Univ. Delft (Netherlands) [6072-21]

9:50 am: **Fingerprinting with Wow**, S. A. Craver, Binghamton Univ. [6072-22]

Coffee Break 10:10 to 10:40 am

SESSION 6

Conv. Ctr. Room A5 Tues. 10:40 am to 12:00 pm

Steganography and Steganalysis II

Chair: Benoit B. Macq, Univ. Catholique de Louvain (Belgium)

10:40 am: **Limited distortion in LSB steganography**, Y. Kim, Z. Duric, D. Richards, George Mason Univ. [6072-23]

11:00 am: **Multiclass blind steganalysis for JPEG images**, J. Fridrich, T. Pevny, Binghamton Univ. [6072-24]

11:20 am: **MPsteg: hiding a message in the matching pursuit domain**, G. Cancelli, M. Barni, G. Menegaz, Univ. degli Studi di Siena (Italy) [6072-25]

11:40 am: **Stego sensitivity measure and multibit plane based steganography using different color models**, S. S. Agaian, J. P. Perez, B. M. Rodriguez II, The Univ. of Texas at San Antonio [6072-26]

Lunch/Exhibition Break 12:00 to 1:30 pm

SESSION 7

Conv. Ctr. Room A5 Tues. 1:30 to 4:20 pm

Embedding I

Chair: Ping Wah Wong, IDzap LLC

1:30 pm: **Zero knowledge ST-DM watermarking**, A. Piva, D. Corazzi, A. De Rosa, Univ. degli Studi di Firenze (Italy); M. Barni, Univ. degli Studi di Siena (Italy) [6072-27]

1:50 pm: **Compression and rotation resistant watermark using a circular chirp structure**, C. E. Fleming, B. G. Mobasser, Villanova Univ. [6072-28]

2:10 pm: **Rotation/scale insensitive spread spectrum image watermarking game**, M. Ossonce, G. Le Guelvouit, C. Delpha, P. Duhamel, Lab. des signaux et systèmes (France) [6072-29]

2:30 pm: **New results on robustness of secure steganography**, M. T. Hogan, F. Balado, N. J. Hurley, G. C. M. Silvestre, National Univ. of Ireland/Dublin (Ireland) [6072-30]

2:50 pm: **Sphere-hardening dither modulation**, F. Balado, N. J. Hurley, G. C. M. Silvestre, National Univ. of Ireland/Dublin (Ireland) [6072-31]

Coffee Break 3:10 to 3:40 pm

3:40 pm: **Secret dither estimation in lattice-quantization data hiding: a set membership approach**, L. L. Pérez-Freire, F. Pérez-González, P. Comesaña Alfaro, Univ. de Vigo (Spain) [6072-32]

4:00 pm: **Performance analysis of nonuniform quantization-based data hiding**, J. E. Vila-Forcén, S. V. Voloshynovskiy, O. J. Koval, T. Pun, Univ. de Genève (Switzerland) [6072-33]

SESSION 8

Conv. Ctr. Room A5 Tues. 4:20 to 5:40 pm

Special Session: Forensics

Chair: Nasir D. Memon, Polytechnic Univ.

4:20 pm: **Detecting digital image forgeries using sensor pattern noise**, J. Lukas, J. Fridrich, M. Goljan, Binghamton Univ. [6072-34]

4:40 pm: **Fingerprinting digital elevation maps**, H. Gou, M. Wu, Univ. of Maryland/College Park [6072-35]

5:00 pm: **Information embedding and extraction for electrophotographic printing processes**, A. K. Mikkilineni, P. Chiang, G. T. Chiu, J. P. Allebach, E. J. Delp III, Purdue Univ. [6072-36]

5:20 pm: **An online system for classifying computer graphics images from natural photographs**, T. Ng, S. Chang, Columbia Univ. [6072-37]

Demonstration Session

A symposium-wide demonstration session will be open to attendees 5:30 to 8:30 pm Tuesday evening in Conv. Ctr. Exhibit Hall 1.

Demonstrators will provide interactive, hands-on demonstrations of a wide-range of products related to Electronic Imaging.

Wednesday 18 January

Plenary Speaker Wed. 8:30 to 9:15 am

Marriott Ballroom 1-6

Computational Imaging Methods for Functional Brain Mapping and Molecular Imaging

Richard Leahy, Univ. of Southern California

See p. 7 for details.

SESSION 9

Conv. Ctr. Room A5 Wed. 9:30 to 11:20 am

Theoretical Methods I

Chair: Pierre Moulin, Univ. of Illinois at Urbana-Champaign

9:30 am: **Text data-hiding for digital and printed documents: theoretical and practical considerations**, R. Villan, Sr., S. V. Voloshynovskiy, O. J. Koval, J. E. Vila-Forcén, E. Topak, F. Deguillaume, Y. B. Rytsar, T. Pun, Univ. de Genève (Switzerland) [6072-38]

9:50 am: **E-capacity and security analysis of data-hiding channels with geometrical attacks**, E. Topak, S. V. Voloshynovskiy, O. J. Koval, Univ. de Genève (Switzerland); M. E. Haroutunian, National Academy of Sciences of Armenia (Armenia); J. E. Vila-Forcén, T. Pun, Univ. de Genève (Switzerland) [6072-39]

10:10 am: **Image data hiding based on capacity-approaching dirty-paper coding**, Y. Yang, Y. Sun, V. Stankovic, Z. Xiong, Texas A&M Univ. [6072-40]

Coffee Break 10:30 to 11:00 am

11:00 am: **Wet paper codes with improved embedding efficiency**, J. Fridrich, M. Goljan, D. Soukal, Binghamton Univ. [6072-41]

Conference 6072 • Conv. Ctr. Room A5

SESSION 10

Conv. Ctr. Room A5 Wed. 11:20 am to 12:20 pm

Video I

Chair: **Adnan M. Alattar**, Digimarc Corp.

- 11:20 am: **New modulation-based watermarking technique for video**, A. N. Lemma, M. van der Veen, M. U. Celik, Philips Research Labs. (Netherlands) [6072-42]
- 11:40 am: **Selective encryption for H.264/AVC video coding**, T. Shi, B. King, P. Salama, Indiana Univ./Purdue Univ. at Indianapolis [6072-43]
- 12:00 pm: **Using entropy for image and video authentication watermarks**, S. Thiemert, M. Steinebach, Fraunhofer-Institut für Integrierte Publikations- und Informationssysteme (Germany) [6072-44]
- Lunch/Exhibition Break 12:20 to 1:50 pm

SESSION 11

Conv. Ctr. Room A5 Wed. 1:50 to 3:10 pm

Video II

Chair: **Ahmet M. Eskicioglu**, The City Univ. of New York

- 1:50 pm: **Temporal synchronization of marked MPEG video frames based on image hash system**, E. Hauer, M. Steinebach, Fraunhofer-Institut für Integrierte Publikations- und Informationssysteme (Germany) [6072-45]
- 2:10 pm: **Towards robust compressed-domain video watermarking for H.264**, M. Noorkami, R. M. Mersereau, Georgia Institute of Technology [6072-46]
- 2:30 pm: **Selective encryption of low-complexity source coding for mobile terminals**, H. Um, E. J. Delp III, Purdue Univ. [6072-47]
- 2:50 pm: **VLC pair tree: a paradigm for MPEG-2 watermarking**, M. P. Marcinak, B. G. Mobasser, Villanova Univ. [6072-48]
- Coffee Break 3:10 to 3:40 pm

SESSION 12

Conv. Ctr. Room A5 Wed. 3:40 to 5:40 pm

Theoretical Methods II

Chair: **Fernando Pérez-González**, Univ. de Vigo (Spain)

- 3:40 pm: **Information-theoretic analysis of electronic and printed document authentication**, S. V. Voloshynovskiy, O. J. Koval, R. Villan, Sr., E. Topak, J. E. Vila-Forcén, F. Deguillaume, Y. B. Rytsar, T. Pun, Univ. de Genève (Switzerland) [6072-49]
- 4:00 pm: **Joint data hiding and source coding with partially available side information**, C. Dikici, K. Idrissi, A. M. Baskurt, Institut National des Sciences Appliquées de Lyon (France) [6072-50]
- 4:20 pm: **Asymmetrically informed data-hiding optimization of achievable rate for Laplacian host**, J. E. Vila-Forcén, O. J. Koval, S. V. Voloshynovskiy, E. Topak, T. Pun, Univ. de Genève (Switzerland) [6072-51]
- 4:40 pm: **Some theoretical aspects of watermarking detection**, T. Furon, J. Josse, S. Le Squin, Institut National de Recherche en Informatique et en Automatique (France) [6072-52]
- 5:00 pm: **A framework for the design of good watermark identification codes**, P. Moulin, R. Koetter, Univ. of Illinois at Urbana-Champaign [6072-53]
- 5:20 pm: **On the fundamental tradeoff between watermark detection performance and robustness against sensitivity analysis attacks**, M. M. El Choubassi, P. Moulin, Univ. of Illinois at Urbana-Champaign [6072-16]

Thursday 19 January

SESSION 13

Conv. Ctr. Room A5 Thurs. 8:00 to 10:00 am

Special Session: Benchmarking and Demonstration Session

Chairs: **Jana Dittmann**, Otto-von-Guericke-Univ. Magdeburg (Germany); **Benoît B. Macq**, Univ. Catholique de Louvain (Belgium)

- 8:00 am: **Profiles for evaluation: the usage of audio WET**, A. Lang, J. Dittmann, Otto-von-Guericke-Univ. Magdeburg (Germany) [6072-54]
- 8:20 am: **A benchmark assessment of the WAUC watermarking audio algorithm**, D. Megías Jiménez, J. Herrera-Joancomarti, J. Serra i Ruiz, J. Minguillón Alfonso, Univ. Oberta de Catalunya (Spain) [6072-55]
- 8:40 am: **Transparency benchmarking on audio watermarks and steganography**, C. Kraetzer, J. Dittmann, A. Lang, Otto-von-Guericke-Univ. Magdeburg (Germany) [6072-56]
- 9:00 am: **Shape quality measurement for 3D watermarking schemes**, P. Rondao-Alface, B. B. Macq, Univ. Catholique de Louvain (Belgium) [6072-57]
- 9:20 am: **Reliability engineering approach to digital watermark evaluation**, H. C. Kim, E. J. Delp III, O. Guitart, E. J. Delp III, Purdue Univ. [6072-58]
- 9:40 am: **New functionalities in watermark evaluation testbed (WET)**, O. Guitart, H. C. Kim, E. J. Delp III, Purdue Univ. [6072-59]
- Coffee Break 10:00 to 10:30 am

SESSION 14

Conv. Ctr. Room A5 Thurs. 10:30 to 11:50 am

Applications I

Chair: **Gordon W. Braudaway**, IBM Corp.

- 10:30 am: **Protection and governance of MPEG music player MAF contents using MPEG-21 IPMP tools**, H. Hendry, M. Kim, Information and Communications Univ. (South Korea) [6072-60]
- 10:50 am: **Watermarking of 3D objects based on 2D apparent contours**, J. Bennour, J. Dugelay, Institut Eurécom (France) [6072-61]
- 11:10 am: **Quality assessment of watermarked 3D polygonal models**, W. Funk, J. Prasiswa, Fraunhofer-Institut für Graphische Datenverarbeitung (Germany) [6072-62]
- 11:30 am: **Reducing the processing time of the hierarchical watermark detector when applied to unmarked images**, A. M. Alattar, O. M. Alattar, Digimarc Corp. [6072-63]
- Lunch Break 11:50 am to 1:20 pm

SESSION 15

Conv. Ctr. Room A5 Thurs. 1:20 to 2:20 pm

Applications II

Chair: **Min Wu**, Univ. of Maryland/College Park

- 1:20 pm: **Exploring QIM-based anti-collusion fingerprinting for multimedia**, A. Swaminathan, S. He, M. Wu, Univ. of Maryland/College Park [6072-64]
- 1:40 pm: **Sheet music fingerprinting based on graphical representation**, G. Kremser, M. Schmucker, Fraunhofer-Institut für Graphische Datenverarbeitung (Germany) [6072-66]
- 2:00 pm: **A web-oriented and interactive buyer-seller watermarking protocol**, F. Frattolillo, S. D'Onofrio, Univ. degli Studi del Sannio (Italy) [6072-67]

Conference 6072 • Conv. Ctr. Room A5

SESSION 16

Conv. Ctr. Room A5 Thurs. 2:20 to 5:10 pm

Embedding II

Chair: Mauro Barni, Univ. degli Studi di Siena (Italy)

2:20 pm: **Matrix embedding for large payloads**, J. Fridrich, D. Soukal, Binghamton Univ. [6072-68]

2:40 pm: **Simple reversible watermarking schemes: further results**, D. Coltuc, Univ. Valahia din Targoviste (Romania); J. Chassery, Institut National Polytechnique de Grenoble (France) [6072-69]

Coffee Break 3:00 to 3:30 pm

3:30 pm: **A new watermark detector for spread-spectrum based image watermarking using underdetermined independent component analysis framework**, H. M. Malik, A. A. Khokhar, R. Ansari, Univ. of Illinois at Chicago [6072-70]

3:50 pm: **Optimal detector for an additive watermarking scheme based on human auditory system**, M. Haddad, A. Gilloire, A. Le Guyader, France Télécom (France); P. Duhamel, Lab. des signaux et systèmes (France) [6072-71]

4:10 pm: **A hypothesis testing approach for achieving semi-fragility in multimedia authentication**, C. Fei, Univ. of Toronto (Canada); D. Kundur, Texas A&M Univ.; R. Kwong, Univ. of Toronto (Canada) [6072-72]

4:30 pm: **A DWT-based robust semi-blind image watermarking algorithm using two bands**, E. Elbasi, A. M. Eskicioglu, The City Univ. of New York [6072-73]

4:50 pm: **Evaluating the visual quality of watermarked images**, A. Shnayderman, A. M. Eskicioglu, The City Univ. of New York [6072-74]

Conference 6073 • Conv. Ctr. Room B1

Tuesday-Thursday 17-19 January 2006 • Proceedings of SPIE Vol. 6073

Multimedia Content Analysis, Management, and Retrieval 2006

Conference Chairs: **Edward Y. Chang**, Univ. of California/Santa Barbara; **Alan Hanjalic**, Delft Univ. of Technology (Netherlands); **Nicu Sebe**, Univ. van Amsterdam (Netherlands)

Program Committee: **Kiyoharu Aizawa**, The Univ. of Tokyo (Japan); **Aya Aner-Wolf**, GenTech Corp. (Israel); **Noboru Babaguchi**, Osaka Univ. (Japan); **Nozha Boujemaa**, INRIA Rocquencourt (France); **Arbee L. P. Chen**, National Chengchi Univ. (Taiwan); **Tsuhuan Chen**, Carnegie Mellon Univ.; **TatSeng Chua**, National Univ. of Singapore (Singapore); **Ajay Divakaran**, Mitsubishi Electric Research Labs.; **Chitra Dorai**, IBM Thomas J. Watson Research Ctr.; **Arun Hampapur**, IBM Thomas J. Watson Research Ctr.; **Alexander G. Hauptmann**, Carnegie Mellon Univ.; **Alejandro Jaimes**, Fuji Xerox Co., Ltd. (Japan); **Mohan S. Kankanhalli**, National Univ. of Singapore (Singapore); **John R. Kender**, Columbia Univ.; **Anil C. Kokaram**, The Univ. of Dublin, Trinity College (Ireland); **Michael S. Lew**, Leiden Institute of Advanced Computer Science (Netherlands); **Chung-Sheng Li**, IBM Corp.; **Rainer W. Lienhart**, Univ. of Augsburg (Germany); **Wei-Ying Ma**, Microsoft Research Asia (China); **Bernard Merialdo**, Institut Eurécom (France); **Kadir A. Peker**, Mitsubishi Electric Research Labs.; **Silvia Pfeiffer**, Commonwealth Scientific & Industrial Research Organisation (Australia); **Alan F. Smeaton**, Dublin City Univ. (Ireland); **John R. Smith**, IBM Thomas J. Watson Research Ctr.; **Hari Sundaram**, Arizona State Univ.; **Ahmet M. Tekalp**, Univ. of Rochester; **Qi Tian**, The Univ. of Texas at San Antonio; **Svetha Venkatesh**, Curtin Univ. of Technology (Australia); **Stephen T. C. Wong**, Harvard Medical School; **Marcel Worring**, Univ. van Amsterdam (Netherlands); **Aidong Zhang**, SUNY/Univ. at Buffalo

Tuesday 17 January

Plenary Speaker **Tues. 8:30 to 9:15 am**

Marriott Ballroom 1-6

Image Processing: Interconnections

Thomas S. Huang, Beckman Institute for Advanced Science and Technology, Univ. of Illinois at Urbana-Champaign

See p. 7 for details.

✓ Posters and Demonstrations-Tuesday

Demonstrations **5:30 to 8:30 pm**

A symposium-wide demonstration session will be open to attendees 5:30 to 8:30 pm Tuesday evening in Conv. Ctr. Exhibit Hall 1.

Demonstrators will provide interactive, hands-on demonstrations of a wide-range of products related to Electronic Imaging.

Posters **5:30 to 7:00 pm**

Posters will be placed on display after 10:00 am in Exhibit Hall 1. A poster session, with authors present at their posters, will be held Tuesday evening, 5:30 to 7:00 pm.

- ✓ **A tree-based paradigm for content-based video retrieval and management**, H. Fang, Univ. of Bradford (United Kingdom); Y. Yin, Chongqing Univ. (China); J. Jiang, Univ. of Bradford (United Kingdom) [6073-31]
- ✓ **Tangible interactive system for document browsing and visualization of multimedia data**, Y. B. Rytsar, S. V. Voloshynovskiy, O. J. Koval, F. Deguillaume, E. Topak, Univ de Genève (Switzerland); S. Startchik, Anteleon Imaging (Switzerland); T. Pun, Univ. de Genève (Switzerland) [6073-32]
- ✓ **Semantic segmentation of video collections using boosted random fields**, B. Janvier, E. Bruno, S. Marchand-Maillet, T. Pun, Univ. de Genève (Switzerland) [6073-33]
- ✓ **Annotating 3D contents with MPEG-7 for reuse purposes**, I. M. Bilasco, J. Gensel, M. Villanova-Oliver, H. Martin, Institut d'Informatique et Mathématiques Appliquées de Grenoble (France) [6073-34]
- ✓ **Multimedia for art retrieval (M4ART)**, E. L. van den Broek, Vrije Univ. Amsterdam (Netherlands); T. Kok, T. E. Schouten, E. Hoenkamp, Radboud Univ. Nijmegen (Netherlands) [6073-35]

- ✓ **Application of image visual characterization and soft feature selection in content-based image retrieval**, K. Jarrah, I. Lee, Ryerson Univ. (Canada); M. J. Kyan, The Univ. of Sydney (Australia); L. Guan, Ryerson Univ. (Canada) [6073-36]
- ✓ **Video shot retrieval using a kernel derived from a continuous HMM**, A. Velivelli, T. S. Huang, Univ. of Illinois at Urbana-Champaign; A. G. Hauptmann, Carnegie Mellon Univ. [6073-37]
- ✓ **Moving camera moving object segmentation in an MPEG-2 compressed video sequence**, J. Wang, Wayne State Univ.; N. Patel, W. Grosky, Univ. of Michigan/Dearborn [6073-38]
- ✓ **Visual object categorization with indefinite kernels in discriminant analysis framework**, S. Kosinov, S. Marchand-Maillet, Univ. de Genève (Switzerland) [6073-39]

Wednesday 18 January

Plenary Speaker **Wed. 8:30 to 9:15 am**

Marriott Ballroom 1-6

Computational Imaging Methods for Functional Brain Mapping and Molecular Imaging

Richard Leahy, Univ. of Southern California

See p. 7 for details.

SESSION 1

Conv. Ctr. Room B1 **Wed. 9:30 to 10:30 am**

Video Analysis I

Chair: Alan F. Smeaton, Dublin City Univ. (Ireland)

- 9:30 am: **Blind summarization: content adaptive video summarization using time-series analysis**, A. Divakaran, R. Radhakrishnan, K. A. Peker, Mitsubishi Electric Research Labs. [6073-01]
- 9:50 am: **Multilevel analysis of sports video sequences**, J. Han, D. Farin, P. H. N. de With, Technische Univ. Eindhoven (Netherlands) [6073-02]
- 10:10 am: **Automated editing of medical training video via content analysis**, A. C. Kokaram, The Univ. of Dublin, Trinity College (Ireland); K. Andrews, Univ. of the West Indies (Trinidad and Tobago); D. Ring, The Univ. of Dublin, Trinity College (Ireland); C. Lee, Royal College of Surgeons in Ireland (Ireland) [6073-03]
- Coffee Break 10:30 to 10:50 am

Conference 6073 • Conv. Ctr. Room B1

SESSION 2

Conv. Ctr. Room B1 Wed. 10:50 am to 12:10 pm

Audio and Video Retrieval

Chair: Anil C. Kokaram, The Univ. of Dublin, Trinity College (Ireland)

10:50 am: **Statistical model and error analysis of a proposed audio fingerprinting algorithm**, E. P. McCarthy, F. Balado, N. J. Hurley, G. C. M. Silvestre, Univ. College Dublin (Ireland) [6073-04]

11:10 am: **An application of weighted transducers to music information retrieval**, D. Basaldella, N. Orio, Univ. degli Studi di Padova (Italy) [6073-05]

11:30 am: **Video scene retrieval with symbol sequence based on integrated audio and visual features**, K. Morisawa, N. Nitta, N. Babaguchi, Osaka Univ. (Japan) [6073-06]

11:50 am: **Fischlár-DiamondTouch: collaborative video searching on a table**, A. F. Smeaton, H. Lee, C. Foley, S. McGivney, C. Gurrin, Dublin City Univ. (Ireland) [6073-07]

Lunch/Exhibition Break 12:10 to 1:40 pm

SESSION 3

Conv. Ctr. Room B1 Wed. 1:40 to 3:00 pm

Image Retrieval

Chair: Nicu Sebe, Univ. van Amsterdam (Netherlands)

1:40 pm: **Mind the gap: another look at the problem of the semantic gap in image retrieval**, J. S. Hare, P. H. Lewis, Univ. of Southampton (United Kingdom); P. Enser, C. Sandom, Univ. of Brighton (United Kingdom) [6073-08]

2:00 pm: **Evaluation of strategies for multiple sphere queries with local image descriptors**, N. Bouteldja, Conservatoire National des Arts et Métiers/CEDRIC (France); V. Gouet-Brunet, M. Scholl, Conservatoire National des Arts et Métiers/CEDRIC (France) [6073-09]

2:20 pm: **PARIS: a MPEG-7 spatial and temporal referenced personal photograph library**, P. Kuo, M. Ito, T. Aoki, H. Yasuda, The Univ. of Tokyo (Japan) [6073-10]

2:40 pm: **2+2=5: painting by numbers**, C. C. Venters, Univ. of Manchester (United Kingdom); R. J. Hartley, Manchester Metropolitan Univ. (United Kingdom); W. T. Hewitt, Univ. of Manchester (United Kingdom) [6073-11]

Coffee Break 3:00 to 3:20 pm

SESSION 4

Conv. Ctr. Room B1 Wed. 3:20 to 4:20 pm

Applications I

Chair: Alan Hanjalic, Technische Univ. Delft (Netherlands)

3:20 pm: **Structuring continuous video recordings of everyday life using time-constrained clustering**, W. Lin, A. G. Hauptmann, Carnegie Mellon Univ. [6073-12]

3:40 pm: **Practical life log video indexing based on content and context**, D. Tancharoen, T. Yamasaki, K. Aizawa, The Univ. of Tokyo (Japan) [6073-13]

4:00 pm: **Multimedia for mobile users: image-enhanced navigation**, S. Gautam, G. Sarkis, E. Tjandranegara, E. Zelikowitz, Y. Lu, E. J. Delp III, Purdue Univ. [6073-14]

Panel Discussion 4:20 to 5:20 pm

Chair: Rainer W. Lienhart, Univ. Augsburg (Germany)

Thursday 19 January

SESSION 5

Conv. Ctr. Room B1 Thurs. 9:00 to 10:00 am

Image Classification

Chair: Michael G. Christel, Carnegie Mellon Univ.

9:00 am: **Semantic classification of business images**, B. Erol, J. J. Hull, Ricoh Innovations, Inc. [6073-15]

9:20 am: **Region labeling using a point-based coherence criterion**, H. Houissa, N. Boujemaa, INRIA Rocquencourt (France) [6073-16]

9:40 am: **BlobContours: adapting Blobworld for supervised color- and texture-based image segmentation**, T. Vogel, D. N. Quyen, J. Dittmann, Otto-von-Guericke-Univ. Magdeburg (Germany) [6073-17]

Coffee Break 10:00 to 10:20 am

SESSION 6

Conv. Ctr. Room B1 Thurs. 10:20 am to 12:20 pm

Special Session: Evaluating Video Summarization, Browsing, and Retrieval Techniques

Chair: Ajay Divakaran, Mitsubishi Electric Research Labs.

10:20 am: **Subjective assessment of consumer video summarization (Invited Paper)**, C. Forlines, K. A. Peker, A. Divakaran, Mitsubishi Electric Research Labs. [6073-18]

10:50 am: **Evaluation of video summarization systems (Invited Paper)**, C. M. Taskiran, Motorola, Inc. [6073-19]

11:20 am: **Subjective evaluation criterion for selecting affective features and modeling highlights (Invited Paper)**, L. Xing, H. Yu, Q. Huang, Graduate School of the Chinese Academy of Sciences (China); Q. Ye, Chinese Academy of Sciences (China); A. Divakaran, Mitsubishi Electric Research Labs. [6073-20]

11:50 am: **Evaluation and user studies with respect to video summarization and browsing (Invited Paper)**, M. G. Christel, Carnegie Mellon Univ. [6073-21]

Lunch Break 12:20 to 2:00 pm

SESSION 7

Conv. Ctr. Room B1 Thurs. 2:00 to 3:00 pm

Feature Extraction

Chair: Edward Y. Chang, Univ. of California/Santa Barbara

2:00 pm: **Semantic feature extraction with multidimensional hidden Markov model**, J. Jiten, B. Meriardo, B. Huet, Eurécom Institute (France) [6073-22]

2:20 pm: **Rotation and translation invariant feature extraction using angular projection in frequency domain**, B. Lee, M. Kim, Information and Communications Univ. (South Korea) [6073-23]

2:40 pm: **Invariant region descriptors for robust shot segmentation**, A. Arasanathan, N. Canagarajah, Univ. of Bristol (United Kingdom) [6073-24]

Coffee Break 3:00 to 3:20 pm

SESSION 8

Conv. Ctr. Room B1 Thurs. 3:20 to 4:20 pm

Video Analysis II

Chair: Rainer W. Lienhart, Univ. Augsburg (Germany)

3:20 pm: **A video processing method for convenient mobile reading of printed barcodes with camera phones**, C. H. Bäckström, C. Södergård, VTT Information Technology (Finland); S. Udd, UPC Consulting Ltd. (Finland)[6073-25]

3:40 pm: **Flexible surveillance system architecture for prototyping video content analysis algorithms**, R. Wijnhoven, Bosch Security Systems B.V. (Netherlands); E. G. T. Jaspers, P. H. N. de With, LogicaCMG (Netherlands)[6073-26]

4:00 pm: **Motion-based parsing for video from observational psychology**, A. C. Kokaram, E. Doyle, D. Lennon, L. Joyeux, R. Fuller, The Univ. of Dublin, Trinity College (Ireland)[6073-27]

Session Break 4:20 to 4:30 pm

SESSION 9

Conv. Ctr. Room B1 Thurs. 4:30 to 5:10 pm

Applications II

Chair: Berna Erol, Ricoh Innovations, Inc.

4:30 pm: **Occlusion costing for multimedia object layout in a constrained window**, S. Widdowson, Hewlett Packard Labs. . . [6073-28]

4:50 pm: **Using CART to segment road images**, R. L. Davies, Intel Corp.; R. W. Lienhart, Univ. Augsburg (Germany)[6073-30]

Conference 6074 • Conv. Ctr. Room B4

Monday-Tuesday 16-17 January 2006 • Proceedings of SPIE Vol. 6074

Multimedia on Mobile Devices II

Conference Chairs: **Reiner Creutzburg**, Fachhochschule Brandenburg (Germany); **Jarmo H. Takala**, Tampere Univ. of Technology (Finland); **Chang Wen Chen**, Florida Institute of Technology

Program Committee: **David Akopian**, The Univ. of Texas at San Antonio; **Alan Chalmers**, Univ. of Bristol (United Kingdom); **Surendar Chandra**, Univ. of Notre Dame; **Kenneth J. Crisler**, Motorola Labs.; **David S. Doermann**, Univ. of Maryland/College Park; **Uwe Dummann**, Siemens AG (Germany); **Elizabeth Dykstra-Erickson**, Kinoma, Inc.; **Zhihai He**, Univ. of Missouri/Columbia; **Xin Li**, West Virginia Univ.; **Sethuraman Panchanathan**, Arizona State Univ.; **Kari A. Pulli**, Nokia; **Matthias Rauterberg**, Technische Univ. Eindhoven (Netherlands); **Phillip A. Regalia**, Institut National des Télécommunications (France); **Haitao Zheng**, Univ. of California/Santa Barbara

Monday 16 January

SESSION 1

Conv. Ctr. Room B4 Mon. 9:30 to 10:00 am

Invited Paper I

9:30 am: **New APIs for mobile graphics (Invited Paper, Presentation Only)**, K. A. Pulli, Nokia [6074-01]

SESSION 2

Conv. Ctr. Room B4 Mon. 10:00 to 10:20 am

Multimedia Coding I

Chair: **Reiner Creutzburg**, Fachhochschule Brandenburg (Germany)
10:00 am: **A novel fast inter-prediction mode decision for H.264/AVC**, Y. Guo, H. Li, S. Pei, Univ. of Science and Technology of China (China); C. W. Chen, Florida Institute of Technology [6074-02]
Coffee Break 10:20 to 10:50 am

SESSION 3

Conv. Ctr. Room B4 Mon. 10:50 am to 12:10 pm

Multimedia Coding II

Chair: **Chang Wen Chen**, Florida Institute of Technology
10:50 am: **Concealment driven bit rate reduction using the H.264 video coding standard**, S. T. Beesley, A. J. Armstrong, C. Grecos, D. J. Parish, Loughborough Univ. (United Kingdom) [6074-03]
11:10 am: **Image embedded coding with edge preservation based on local variance analysis for mobile applications**, G. Luo, D. Osypiw, Buckinghamshire Chilterns Univ. College (United Kingdom) [6074-04]
11:30 am: **Image coding using adaptive resizing in the block-DCT domain**, J. J. Koivusaari, J. H. Takala, M. Gabbouj, Tampere Univ. of Technology (Finland) [6074-05]
11:50 am: **Spatial scalability of multiple ROIs in scalable video coding**, T. M. Bae, T. C. Thang, D. Y. Kim, Y. M. Ro, Information and Communications Univ. (South Korea); J. Kim, Electronics and Telecommunications Research Institute (South Korea) [6074-06]
Lunch Break 12:10 to 2:00 pm

SESSION 4

Conv. Ctr. Room B4 Mon. 2:00 to 2:30 pm

Invited Paper II

2:00 pm: **Implementing energy efficient embedded multimedia (Invited Paper)**, O. J. Silvén, Univ. of Oulu (Finland) [6074-07]

SESSION 5

Conv. Ctr. Room B4 Mon. 2:30 to 3:10 pm

Mobile Multimedia Retrieval and Classification

Chair: **Stefan Edlich**, Technische Fachhochschule Berlin (Germany)
2:30 pm: **A study of low-complexity tools for semantic classification of mobile images and video**, A. Mariappan, M. Igarta, Purdue Univ.; C. M. Taskiran, B. Gandhi, Motorola, Inc.; E. J. Delp III, Purdue Univ. [6074-08]
2:50 pm: **Audio-based queries for video retrieval over Java enabled mobile devices**, I. Ahmad, Nokia Corp. (Finland); F. A. Cheikh, S. Kiranyaz, M. Gabbouj, Tampere Univ. of Technology (Finland) [6074-09]
Coffee Break 3:10 to 3:30 pm

SESSION 6

Conv. Ctr. Room B4 Mon. 3:30 to 5:10 pm

Processors for Multimedia

Chair: **Jarmo H. Takala**, Tampere Univ. of Technology (Finland)
3:30 pm: **Parallel implementation of MPEG-2 video decoder**, A. Sarkar, North Carolina State Univ.; K. Saha, S. Maiti, STMicroelectronics Pvt. Ltd. (India) [6074-11]
3:50 pm: **Software-based geometry operations for 3D computer graphics**, M. Sima, Univ. of Victoria (Canada); D. Iancu, J. C. Glossner, Sandbridge Technologies, Inc.; M. J. Schulte, S. Mamidi, Univ. of Wisconsin/Madison [6074-12]
4:10 pm: **MVSP: multithreaded VLIW stream processor**, S. Sardashti, H. R. Ghasemi, O. Fatemi, Univ. of Tehran (Iran) [6074-13]
4:30 pm: **System-on-chip architecture with media DSP and RISC core for media application**, P. Liu, W. Wang, Q. Yao, Zhejiang Univ. (China) [6074-14]
4:50 pm: **IIA: a novel method to optimize media instruction set of embedded processor**, K. Chen, Q. Yao, W. Wang, P. Liu, Zhejiang Univ. (China) [6074-15]

Tuesday 17 January

Plenary Speaker Tues. 8:30 to 9:15 am

Marriott Ballroom 1-6

Image Processing: Interconnections

Thomas S. Huang, Beckman Institute for Advanced Science and Technology, Univ. of Illinois at Urbana-Champaign

See p. 7 for details.

SESSION 7

Conv. Ctr. Room B4 Tues. 9:30 to 10:00 am

Invited Paper III

9:30 am: **Multimedia services for next-generation mobile networks (Invited Paper)**, S. J. Wee, D. Penkler, Hewlett-Packard Labs. [6074-17]

Conference 6074 • Conv. Ctr. Room B4

SESSION 8

Conv. Ctr. Room B4 Tues. 10:00 to 10:20 am

Multimedia Applications I

Chair: **Reiner Creutzburg**, Fachhochschule Brandenburg (Germany)
10:00 am: **Wireless steganography**, S. S. Agaian, D. Akopian, S. D'Souza, The Univ. of Texas at San Antonio [6074-18]
Coffee Break 10:20 to 10:50 am

SESSION 9

Conv. Ctr. Room B4 Tues. 10:50 am to 12:10 pm

Multimedia Applications II

Chair: **Zhihai He**, Univ. of Missouri/Columbia
10:50 am: **Image processing for navigation on a mobile embedded platform**, H. Loose, C. Lemke, C. Papazov, Brandenburg Univ. of Applied Sciences (Germany) [6074-19]
11:10 am: **Image processing for navigation on a mobile embedded platform**, T. Preuss, L. Gentsch, M. Rambow, Brandenburg Univ. of Applied Sciences (Germany) [6074-20]
11:30 am: **The future is 'ambient'**, A. R. Lugmayr, Tampere Univ. of Technology (Finland) [6074-21]
11:50 am: **Embedded video surveillance system for vehicle over WLAN and CDMA1X**, L. Ming, Wuhan Univ. (China) [6074-22]
Lunch Break 12:10 to 1:40 pm

SESSION 10

Conv. Ctr. Room B4 Tues. 1:40 to 3:00 pm

Multimedia Data Management

Chair: **David Akopian**, The Univ. of Texas at San Antonio
1:40 pm: **Performance analysis of MPEG-21 technologies on mobile devices**, S. De Zutter, F. De Keukelaere, C. Poppe, R. Van de Walle, Univ. Gent (Belgium) [6074-23]
2:00 pm: **TV-anytime and MPEG-21 DIA based ubiquitous content mobility prototype system for multi-users**, M. Kim, C. Yang, J. Lim, M. Kim, Information and Communications Univ. (South Korea); S. Park, K. Kim, SAMSUNG Electronics Co., Ltd. (South Korea) [6074-24]
2:20 pm: **Multimedia-based construction management and supervision on mobile JTWI devices and the EDF-portal**, S. Edlich, Technische Fachhochschule Berlin (Germany); R. Strauch, edv plan GmbH; L. Visengeriyeva, Fachhochschule Brandenburg; D. Reeck, edv plan GmbH [6074-25]
2:40 pm: **A mobile phone-based context-aware video management application**, J. Lahti, M. Palola, J. Korva, VTT Technical Research Ctr. of Finland (Finland); U. Westermann, P. Pietarila, VTT Elektroniikka (Finland); K. Pentikousis, VTT Technical Research Ctr. of Finland (Finland) [6074-26]
Coffee Break 3:00 to 3:30 pm

SESSION 11

Conv. Ctr. Room B4 Tues. 3:30 to 5:10 pm

HCI Issues for Mobile Devices

Chair: **Jarmo H. Takala**, Tampere Univ. of Technology (Finland)
3:30 pm: **MIKE's PET: a participant-based experiment tracking tool for HCI practitioners using mobile devices**, D. Mohamedally, City Univ. London (United Kingdom); S. Edlich, Technische Fachhochschule Berlin (Germany); E. Klaus, Fachhochschule Brandenburg (Germany); P. Zaphiris, H. Petrie, City Univ. London (United Kingdom) [6074-27]
3:50 pm: **Maintenance support: case study for a multimodal mobile interface**, G. Fuchs, D. Reichart, H. Schumann, P. Forbrig, Univ. Rostock (Germany) [6074-28]
4:10 pm: **Breaking the news on mobile TV: user requirements of a popular mobile content**, H. O. Knoche, Univ. College London; A. Sasse, Univ. College London (United Kingdom) [6074-29]
4:30 pm: **Multimodal audio guide for museums and exhibitions**, S. Gebbensleben, J. Dittmann, Otto-von-Guericke Univ. (Germany) [6074-30]
4:50 pm: **Human sound detection on experience movies**, S. Shimura, Y. Hirano, S. Kajita, K. Mase, Nagoya Univ. (Japan) [6074-31]

✓ Posters and Demonstrations-Tuesday

Demonstrations 5:30 to 8:30 pm

A symposium-wide demonstration session will be open to attendees 5:30 to 8:30 pm Tuesday evening in Conv. Ctr. Exhibit Hall 1. Demonstrators will provide interactive, hands-on demonstrations of a wide-range of products related to Electronic Imaging.

Posters 5:30 to 7:00 pm

Posters will be placed on display after 10:00 am in Exhibit Hall 1. A poster session, with authors present at their posters, will be held Tuesday evening, 5:30 to 7:00 pm.

- ✓ **A FGS coding method based on LC multiwavelet transform**, W. Liu, South China Normal Univ. (China); Z. Ma, Zhongshan Univ. (China) [6074-34]
- ✓ **A context-aware video display scheme for mobile devices**, K. Seo, C. Kim, Information and Communications Univ. (South Korea) [6074-35]
- ✓ **Verification of WIPI-based T-DMB platform for interactive mobile multimedia services**, B. Bae, W. Kim, J. Yun, C. Ahn, Electronics and Telecommunications Research Institute (South Korea); K. Sohng, Kyungpook National Univ. (South Korea) [6074-36]
- ✓ **New TPEG applications based on digital multimedia broadcasting**, Y. Jeong, S. Cho, G. Kim, C. Ahn, S. Lee, Electronics and Telecommunications Research Institute (South Korea); W. Kim, Chungnam National Univ. (South Korea) [6074-37]
- ✓ **AROMA: augmented reality on mobile devices API (Java)**, S. Edlich, Technische Fachhochschule Berlin (Germany); H. Hörning, R. Hörning, Biting Bit (Germany) [6074-39]
- ✓ **An effective method and its implementation for splicing in terrestrial DMB**, Y. Lee, J. Lee, G. Lee, C. Ahn, S. Lee, Electronics and Telecommunications Research Institute (South Korea); N. Kim, Chungbuk National Univ. (South Korea) [6074-40]
- ✓ **Media digital signal processor core design for multimedia application**, P. Liu, G. Yu, W. Cai, Q. Yao, Zhejiang Univ. (China) [6074-42]

Conference 6075 • Conv. Ctr. Room A7

Tuesday-Thursday 17-19 January 2006 • Proceedings of SPIE Vol. 6075

Optical Security and Counterfeit Deterrence Techniques VI

Conference Chair: **Rudolf L. van Renesse**, VanRenesse Consulting (Netherlands)

Program Committee: **Sara E. Church**, Bank of Canada (Canada); **James M. Jonza**, 3M Co.; **Malcolm R. M. Knight**, De La Rue International Ltd. (United Kingdom); **Ian M. Lancaster**, Reconnaissance International (United Kingdom) and International Hologram Manufacturers Association (United Kingdom); **Hiroyuki Matsumoto**, NHK Spring Co., Ltd. (Japan); **Roger W. Phillips**, JDSU-Flex Products Group; **Elisabeth Schulz**, European Central Bank (Germany); **Sybrand Spannburg**, Joh. Enschedé Security Printing B.V. (Netherlands); **Wayne R. Tompkin**, OVD Kinegram Corp. (Switzerland); **Jan van den Berg**, Sdu Identification (Netherlands)

Tuesday 17 January

Plenary Speaker **Tues. 8:30 to 9:15 am**
Marriott Ballroom 1-6
Image Processing: Interconnections
Thomas S. Huang, Beckman Institute for Advanced Science and Technology, Univ. of Illinois at Urbana-Champaign
See p. 7 for details.

✓ Posters and Demonstrations-Tuesday

Demonstrations **5:30 to 8:30 pm**
A symposium-wide demonstration session will be open to attendees 5:30 to 8:30 pm Tuesday evening in Conv. Ctr. Exhibit Hall 1. Demonstrators will provide interactive, hands-on demonstrations of a wide-range of products related to Electronic Imaging.

Posters **5:30 to 7:00 pm**
Posters will be placed on display after 10:00 am in Exhibit Hall 1. A poster session, with authors present at their posters, will be held Tuesday evening, 5:30 to 7:00 pm.

- ✓ **Use of metameric filters for future interference security images structures**, B. Baloukas, L. Martin, École Polytechnique de Montréal (Canada) [6075-42]
- ✓ **Recording the optical identification marks on CDs**, A. A. Kryuchyn, Institute for Information Recording (Ukraine); S. A. Kostyukevych, V. Lashkaryov Institute of Semiconductor Physics (Ukraine); V. V. Petrov, S. M. Shanoylo, Institute for Information Recording (Ukraine) ... [6075-40]
- ✓ **Concealed images in design of security devices and methods of their authentication**, V. I. Girnyk, Optronics, Ltd. (Ukraine); S. O. Kostyukevich, Optronics, Ltd. (Ukraine) and Institute of Semiconductor Physics (Ukraine); E. V. Braginets, Optronics, Ltd. (Ukraine) and National Taras Shevchenko Univ. of Kyiv (Ukraine); A. Soroka, National Taras Shevchenko Univ. of Kyiv (Ukraine) [6075-41]

Wednesday 18 January

Plenary Speaker **Wed. 8:30 to 9:15 am**
Marriott Ballroom 1-6
Computational Imaging Methods for Functional Brain Mapping and Molecular Imaging
Richard Leahy, Univ. of Southern California
See p. 7 for details.

SESSION 1

Conv. Ctr. Room A7 **Wed. 9:30 to 10:30 am**
Currency I

Chair: Sara E. Church, Bank of Canada (Canada)

- 9:30 am: **Feed back from the public for better banknote design**, H. A. M. de Heij, De Nederlandsche Bank (Netherlands) [6075-01]
- 9:50 am: **Robust and reliable banknote authentication and print flaw detection with opto-acoustical sensor fusion methods**, V. Lohweg, Fachhochschule Lippe und Höxter (Germany); J. G. Schaede, KBA-GIORI S.A. (Switzerland); T. Türke, KBA-Bielefeld (Germany) [6075-02]
- 10:10 am: **The implication of direct laser engraved intaglio plates on bank note security**, H. Deinhammer, Österreichische Banknoten- und Sicherheitsdruck (Austria) [6075-03]
- Coffee Break 10:30 to 11:00 am

SESSION 2

Conv. Ctr. Room A7 **Wed. 11:00 am to 12:00 pm**
Currency II

Chair: Elisabeth Schulz, European Central Bank (Germany)

- 11:00 am: **The circulation simulator method for evaluating bank note and optical feature durability**, W. J. Bartz, Crane & Co., Inc. . . [6075-04]
- 11:20 am: **Visual and optical evaluation of bank notes in circulation**, S. E. Church, M. P. Lacelle, T. Garanzotis, Bank of Canada (Canada) . [6075-05]
- 11:40 am: **The mechanisms of human recognition as a guideline for security feature development**, J. G. Schaede, KBA-GIORI S.A. (Switzerland) [6075-06]
- Lunch/Exhibition Break 12:00 to 1:30 pm

SESSION 3

Conv. Ctr. Room A7 **Wed. 1:30 to 3:10 pm**
Security Image Technology I

Chair: Sybrand Spannburg, Joh. Enschedé Security Printing B.V. (Netherlands)

- 1:30 pm: **Qualification of security printing features**, S. J. Simske, Hewlett-Packard Labs; J. S. Aronoff, Hewlett-Packard Labs.; J. Arnabat, Hewlett-Packard Co. (Spain) [6075-07]
- 1:50 pm: **Potentiality of holographic technique in fragile watermarking (Invited Paper)**, G. Schirripa Spagnolo, Univ. degli Studi di Roma Tre (Italy) [6075-08]
- 2:10 pm: **Secure graphical data storage by full-spectrum image coding**, H. Oltmans, Consultant (Netherlands) [6075-09]
- 2:30 pm: **Sub-pixel analysis to support graphic security after scanning at low resolution**, R. A. Cordery, Pitney Bowes; S. K. Decker, Digimarc Corp.; B. Haas, Pitney Bowes; H. Gou, Univ. of Maryland/College Park [6075-10]
- 2:50 pm: **New applications of modulated digital images in document security**, R. Lee, P. W. Leech, L. D. McCarthy, G. F. Swiegers, Commonwealth Scientific & Industrial Research Organisation (Australia) [6075-11]
- Coffee Break 3:10 to 3:40 pm

Conference 6075 • Conv. Ctr. Room A7

SESSION 4

Conv. Ctr. Room A7 Wed. 3:40 to 5:20 pm

Security Image Technology II

Chair: James M. Jonza, 3M Co.

- 3:40 pm: **Black fluorescent ink and applications**, J. Auslander, R. A. Corderly, Pitney Bowes [6075-37]
- 4:00 pm: **The role of optics in secure credentials**, T. L. Lichtenstein, LaserCard Corp. [6075-13]
- 4:20 pm: **Practical use of lens structures in ID documents**, J. van den Berg, SDU Identification (Netherlands) [6075-14]
- 4:40 pm: **Three-dimensional floating images as overt security features**, D. S. Dunn, T. L. Potts, L. E. Lorimor, J. M. Jonza, R. L. Smithson, S. P. Maki, 3M Co. [6075-15]
- 5:00 pm: **Development of the random-retardation-encoding anti-counterfeiting technology**, W. Huang, C. Tsai, T. Chen, M. Kuan, C. Wen, Industrial Technology Research Institute (Taiwan) [6075-16]

Thursday 19 January

SESSION 5

Conv. Ctr. Room A7 Thurs. 8:10 to 10:10 am

Security Ink Technology

Chair: Roger W. Phillips, JDSU-Flex Products Group

- 8:10 am: **Advanced verification methods for OVI(r) security ink**, P. G. Coombs, Flex Products/JDS Uniphase Corp.; S. F. McCaffery, JDS Uniphase Corp.; T. Markantes, Flex Products/JDS Uniphase Corp. [6075-17]
- 8:30 am: **Overt security features through digital printing**, R. A. Einhorn, M. J. Hampden-Smith, S. Haubrich, J. Shah, R. Bhatia, N. Hardman, R. Kornbrekke, Cabot Corp. [6075-18]
- 8:50 am: **Novel particulate production processes to create unique security materials**, M. J. Hampden-Smith, T. Kodas, S. Haubrich, M. Oljaca, R. A. Einhorn, Cabot Corp. [6075-19]
- 9:10 am: **Combining overt and covert anti-counterfeiting technologies for securities**, T. Uematsu, National Printing Bureau of Japan (Japan) [6075-20]
- 9:30 am: **Bacteriorhodopsin-based multilevel optical security features**, N. A. Hamppp, M. Neebe, I. Yang, Philipps-Univ. Marburg (Germany) [6075-21]
- 9:50 am: **Optical security in ink: an industry standard that continues to evolve**, M. Schmid, SICPA SA (Switzerland) [6075-22]
- Coffee Break 10:10 to 10:40 am

SESSION 6

Conv. Ctr. Room A7 Thurs. 10:40 am to 12:00 pm

Optically Variable Devices I

Chair: Wayne R. Tompkin, OVD Kinegram AG (Switzerland)

- 10:40 am: **Current use and efficacy of optical security devices**, I. M. Lancaster, Reconnaissance International Ltd. (United Kingdom) and International Hologram Manufacturing Association (United Kingdom) [6075-23]
- 11:00 am: **The security enhancement of diffractive optically variable image devices**, A. Argoitia, R. W. Phillips, Flex Products/JDSU [6075-24]
- 11:20 am: **The Aztec structure: an improved replicable security device**, J. J. Cowan, Aztec Systems, Inc. [6075-25]
- 11:40 am: **Combination of optically variable diffractive and multilayer interference structures: a new class of security devices**, V. I. Girnyk, Optronics, Ltd. (Ukraine); R. W. Phillips, JDSU-Flex Products Group; E. V. Braginetz, Optronics, Ltd. (Ukraine) and National Kiev Taras Schevchenko Univ. (Ukraine) [6075-26]
- Lunch Break 12:00 to 1:30 pm

SESSION 7

Conv. Ctr. Room A7 Thurs. 1:30 to 2:30 pm

Optically Variable Devices II

Chair: Ian M. Lancaster, Reconnaissance International Ltd. (United Kingdom)

- 1:30 pm: **Novel optically variable color devices**, M. Stalder, F. Seils, Rolic Technologies Ltd. (Switzerland) [6075-27]
- 1:50 pm: **Diffractive Moiré features for optically variable devices**, A. Schilling, W. R. Tompkin, R. Staub, OVD Kinegram AG (Switzerland); R. D. Hersch, S. Chosson, I. Amidror, École Polytechnique Fédérale de Lausanne (Switzerland) [6075-28]
- 2:10 pm: **Combination of e-beam and optical holography on micro- and macro-levels of OVD**, E. V. Braginetz, V. I. Girnyk, Optronics, Ltd. (Ukraine) and National Taras Shevchenko Univ. (Ukraine); B. Holmes, De La Rue International Ltd. (United Kingdom) [6075-29]

SESSION 8

Conv. Ctr. Room A7 Thurs. 2:30 to 4:20 pm

Authentication, Identification, and Biometrics I

Chair: Malcolm R. M. Knight, De La Rue International Ltd. (United Kingdom)

- 2:30 pm: **Choosing the correct forensic marker(s) in currency, document, and product protection**, J. J. Plimmer, Product & Image Security Foundation (United Kingdom) [6075-30]
- 2:50 pm: **Optically variable threads and polarization effects**, F. Kretschmar, Louisenthal GmbH (Germany) [6075-38]
- Coffee Break 3:10 to 3:40 pm
- 3:40 pm: **Life recognition based on color variations in fingerprint images of live and artificial fingers**, K. Tai, M. Kurita, I. Fujieda, Ritsumeikan Univ. (Japan) [6075-32]
- 4:00 pm: **RFID identity theft and countermeasures**, A. Herrigel, Up-Great AG (Switzerland) [6075-33]

SESSION 9

Conv. Ctr. Room A7 Thurs. 4:20 to 5:20 pm

Authentication, Identification, and Biometrics II

Chair: Rudolf L. van Renesse, VanRenesse Consulting (Netherlands)

- 4:20 pm: **On the use of mobile imaging devices for the validation of first and second line security features**, T. F. Rodriguez, M. Weaver III, Digimarc Corp. [6075-34]
- 4:40 pm: **Facets of color laser marking in high secure ID documents**, F. Kappe, M. Schumacher, ORGA Systems enabling services GmbH (Germany); K. Schäfer, M. Hillebrand, M. Hennemeyer-Schwenkner, D. Fischer, Orga Systems GmbH (Germany) [6075-35]
- 5:00 pm: **Protection of data carriers using secure optical codes**, J. A. Peters, A. Schilling, R. Staub, W. R. Tompkin, OVD Kinegram AG (Switzerland) [6075-36]

Standby Oral Presentation

- 5:40 am: **Public education by Central Banks on the Internet**, R. L. van Renesse, VanRenesse Consulting (Netherlands) [6075-39]

Conference 6076 • Conv. Ctr. Room A7

Monday-Tuesday 16-17 January 2006 • Proceedings of SPIE Vol. 6076

Digital Publishing

Conference Chairs: **Jan P. Allebach**, Purdue Univ.; **Hui Chao**, Hewlett-Packard Co.

Program Committee: **Kathrin Berkner**, Ricoh Innovations, Inc.; **Charles A. Bouman**, Purdue Univ.; **David F. Brailsford**, Univ. of Nottingham (United Kingdom); **Richard Furuta**, Texas A&M Univ.; **Steven J. Harrington**, Xerox Corp.; **Yuukou Horita**, Toyama Univ. (Japan); **Charles Jacobs**, Microsoft Corp.; **Dhiraj Kacker**, Caslon & Co.; **John Lumley**, Hewlett-Packard Ltd. (United Kingdom); **Lisa Purvis**, Xerox Corp.; **Fernando Vega**, Univ. de Puerto Rico Mayagüez; **Fabio Vitali**, Univ. degli Studi di Bologna (Italy)

Monday 16 January

SESSION 1

Conv. Ctr. Room A7 Mon. 9:30 am to 12:00 pm

New Publishing Methods

Chair: **Steven J. Harrington**, Xerox Corp.

- 9:30 am: **E-books and the challenge of preservation (Invited Paper)**, F. Romano, Rochester Institute of Technology [6076-01]
10:10 am: **User centered design of the digital book: why looking backward can help us move forward**, J. C. Wallis, Univ. of California/Los Angeles [6076-02]
Coffee Break 10:30 to 11:00 am
11:00 am: **Interactive publications: creation and usage**, G. R. Thoma, G. Ford, M. Chung, K. Vasudevan, S. K. Antani, National Library of Medicine [6076-03]
11:20 am: **Personalized direct marketing using digital publishing**, L. K. Cheeniyil, J. K. Prabhakaran, Hewlett-Packard Co. (India) [6076-05]
11:40 am: **Automated campaign system**, G. L. Vondran, H. Chao, X. Lin, P. Joshi, D. Beyer, C. B. Atkins, P. Obrador, Hewlett-Packard Co. [6076-06]
Lunch Break 12:00 to 1:30 pm

SESSION 2

Conv. Ctr. Room A7 Mon. 1:30 to 3:10 pm

Document Structure and Style

Chair: **John Lumley**, Hewlett-Packard Ltd. (United Kingdom)

- 1:30 pm: **Is the nature of a document changing (Invited Paper)**, J. C. King, S. Towers, Adobe Systems, Inc. [6076-07]
2:10 pm: **Expression of document structure in automatic layout**, S. J. Harrington, Xerox Corp.; R. Price Jones, J. F. Naveda, Rochester Institute of Technology; N. Thakkar, IBM Corp. [6076-08]
2:30 pm: **Evaluating interface aesthetics: measure of symmetry**, H. Balinsky, Hewlett-Packard Ltd. (United Kingdom) [6076-09]
2:50 pm: **Automatic color scheme picker for document templates based on image analysis and dual problem**, P. Obrador, Hewlett-Packard Labs. [6076-10]
Coffee Break 3:10 to 3:40 pm

SESSION 3

Conv. Ctr. Room A7 Mon. 3:40 to 5:20 pm

Artifact Detection

Chair: **Kathrin Berkner**, Ricoh Innovations, Inc.

- 3:40 pm: **Ring artifact measurement for JPEG images**, X. Feng, J. P. Allebach, Purdue Univ. [6076-11]
4:00 pm: **A hybrid intelligence approach to artifact recognition in digital publishing**, F. Vega, H. J. Santos-Villalobos, Univ. de Puerto Rico Mayagüez [6076-12]
4:20 pm: **Nearest-neighbor and bilinear resampling factor estimation to detect blockiness or blurriness of an image**, A. Suwendi, J. P. Allebach, Purdue Univ. [6076-13]
4:40 pm: **Analytical model of skew effect in digital press characterization**, M. Qiao, J. P. Allebach, Purdue Univ. [6076-14]
5:00 pm: **Detection and location of very small print defects in real time for high-speed digital printing**, G. W. Braudaway, IBM Corp. ... [6076-15]

Tuesday 17 January

Plenary Speaker Tues. 8:30 to 9:15 am

Marriott Ballroom 1-6

Image Processing: Interconnections

Thomas S. Huang, Beckman Institute for Advanced Science and Technology, Univ. of Illinois at Urbana-Champaign

See p. 7 for details.

SESSION 4

Conv. Ctr. Room A7 Tues. 9:30 to 11:20 am

Document and Image Presentation

Chair: **Fabio Vitali**, Univ. degli Studi di Bologna (Italy)

- 9:30 am: **New economy, new strategy: digital technology innovations and applications (Invited Paper)**, N. Raman, Hewlett-Packard Labs. [6076-16]
Coffee Break 10:10 to 10:40 am
10:40 am: **How small should a document thumbnail be?**, K. Berkner, Ricoh Innovations, Inc. [6076-17]
11:00 am: **Image object adaptation in variable data printing**, J. Fan, Hewlett-Packard Labs.; H. Chao, Hewlett-Packard Co. [6076-18]
Lunch/Exhibition Break 11:20 am to 1:20 pm

SESSION 5

Conv. Ctr. Room A7 Tues. 1:20 to 3:00 pm

Document Layout

Chair: Fernando Vega, Univ. de Puerto Rico Mayagüez

1:20 pm: **Laying out the future of final-form digital documents (*Invited Paper*)**, D. F. Brailsford, Univ. of Nottingham (United Kingdom) . . [6076-20]

2:00 pm: **Intelligent content fitting for digital publishing**, X. Lin, Hewlett-Packard Co. [6076-21]

2:20 pm: **A total-fit page-breaking algorithm with user-defined adjustment strategies**, A. Di Iorio, L. Furini, F. Vitali, Univ. degli Studi di Bologna (Italy) [6076-22]

2:40 pm: **Extensible layout in functional documents**, J. Lumley, R. Gimson, O. Rees, Hewlett-Packard Ltd. (United Kingdom) [6076-23]

Coffee Break 3:00 to 3:30 pm

SESSION 6

Conv. Ctr. Room A7 Tues. 3:30 to 5:30 pm

Publishing, Production, and Workflow

Chair: Dhiraj Kacker, Caslon & Co., Inc.

3:30 pm: **Production digital printing: making the leap from emerging to everyday (*Invited Paper*)**, C. Valiquette, Caslon & Co. [6076-24]

4:10 pm: **WARP (workflow for automated and rapid publishing): a framework for end-to-end automated digital publishing workflows**, P. Joshi, Hewlett-Packard Co. [6076-25]

4:30 pm: **A scheduling framework applied to digital publishing workflows**, W. Rivera, W. L'Ozano, Univ. de Puerto Rico Mayagüez [6076-26]

4:50 pm: **Desktop binding: a novel approach to booklet making hardware**, S. W. Trovinger, Hewlett-Packard Co. [6076-27]

5:10 pm: **Color variance in PDF-based production workflows**, M. P. Riordan, Rochester Institute of Technology [6076-28]

Demonstration Session - Tuesday

Conference 6077 • Conv. Ctr. Rooms B2 and B3

Tuesday-Thursday 17-19 January 2006 • Proceedings of SPIE Vol. 6077

Visual Communications and Image Processing 2006

Conference Chairs: **John G. Apostolopoulos**, Hewlett-Packard Labs.; **Amir Said**, Hewlett-Packard Labs.

Program Committee: **Kiyoharu Aizawa**, The Univ. of Tokyo (Japan); **Yucel Altunbasak**, Georgia Institute of Technology; **Alan C. Bovik**, The Univ. of Texas at Austin; **Chang Wen Chen**, Florida Institute of Technology; **Charles D. Creusere**, New Mexico State Univ.; **Gerard de Haan**, Philips Research Labs. (Netherlands); **Edward J. Delp III**, Purdue Univ.; **Eric Dubois**, Univ. of Ottawa (Canada); **Frederic Dufaux**, Emitall S.A. (Switzerland); **Touradj Ebrahimi**, Emitall S.A. (Switzerland); **Onur G. Guleryuz**, DoCoMo Communications Labs. USA, Inc.; **Sheila S. Hemami**, Cornell Univ.; **T. Russell Hsing**, Telcordia Technologies, Inc.; **Lina J. Karam**, Arizona State Univ.; **Janusz Konrad**, Boston Univ.; **Alex C. Kot**, Nanyang Technological Univ. (Singapore); **C.-C. Jay Kuo**, Univ. of Southern California; **Reginald L. Lagendijk**, Technische Univ. Delft (Netherlands); **Shipeng Li**, Microsoft Research Asia (China); **Yi Liang**, Qualcomm; **Bangalore S. Manjunath**, Univ. of California/Santa Barbara; **Peyman Milanfar**, Univ. of California/Santa Cruz; **Sanjit K. Mitra**, Univ. of California/Santa Barbara; **Antonio Ortega**, Univ. of Southern California; **Jörn Ostermann**, Rensselaer Polytechnic Institute; **Fernando M. B. Pereira**, Instituto Superior Técnico (Portugal); **Béatrice Pesquet-Popescu**, École Nationale Supérieure des Télécommunications (France); **Fatih M. Porikli**, Mitsubishi Electric Research Labs.; **Majid Rabbani**, Eastman Kodak Co.; **Kannan Ramchandran**, Univ. of California/Berkeley; **Kenneth Rose**, Univ. of California/Santa Barbara; **Paul Salama**, Indiana Univ./Purdue Univ. at Indianapolis; **Dan Schonfeld**, Univ. of Illinois at Chicago; **Thomas Sikora**, Technische Univ. Berlin (Germany); **Eckehard G. Steinbach**, Ludwig-Maximilians-Univ. München; **Robert L. Stevenson**, Univ. of Notre Dame; **Thomas Stockhammer**, Technische Univ. München (Germany); **Huifang Sun**, Mitsubishi Electric Research Labs.; **Ming-Ting Sun**, Univ. of Washington; **Andrew G. Tescher**, AGT Associates; **Bhaskaran Vasudev**, Epson Palo Alto Lab.; **Anthony Vetro**, Mitsubishi Electric Research Labs.; **John W. Woods**, Rensselaer Polytechnic Institute

Tuesday 17 January

Plenary Speaker Tues. 8:30 to 9:15 am

Marriott Ballroom 1-6

Image Processing: Interconnections

Thomas S. Huang, Beckman Institute for Advanced Science and Technology, Univ. of Illinois at Urbana-Champaign

See p. 7 for details.

Sessions 1 and 2 run concurrently.

SESSION 1

Conv. Ctr. Room B3 Tues. 1:30 to 5:10 pm

Special Session: Superresolution

Chair: Onur G. Guleryuz, DoCoMo Communications Labs. USA, Inc.

1:30 pm: **Superresolution of text from nonideal video (Invited Paper)**, X. Li, West Virginia Univ. [6077-01]

1:55 pm: **Registration of aliased images for super-resolution imaging (Invited Paper)**, P. Vandewalle, L. M. Sbaiz, S. E. Süsstrunk, École Polytechnique Fédérale de Lausanne (Switzerland); M. Vetterli, École Polytechnique Fédérale de Lausanne (Switzerland) and Univ. of California/Berkeley [6077-02]

2:20 pm: **A practical approach to superresolution (Invited Paper)**, S. Farsiu, Univ. of California/Santa Cruz; M. Elad, Technion - Israel Institute of Technology (Israel); P. Milanfar, Univ. of California/Santa Cruz . . . [6077-03]

2:45 pm: **Jitter camera: a superresolution video camera (Invited Paper)**, M. Ben-Ezra, Siemens Corporate Research; A. Zomet, S. K. Nayar, Columbia Univ. [6077-04]

Coffee Break 3:10 to 3:40 pm

3:40 pm: **Face recognition with independent component based superresolution (Invited Paper)**, O. G. Sezer, Sabanci Univ. (Turkey); Y. Altunbasak, Georgia Institute of Technology; A. Ercil, Sabanci Univ. (Turkey) [6077-05]

4:05 pm: **Toward new a compression standard using superresolution techniques (Invited Paper)**, R. Molina, Univ. de Granada (Spain); A. K. Katsaggelos, Northwestern Univ.; L. Alvarez, J. Mateos, Univ. de Granada (Spain) [6077-25]

4:30 pm: **Robust superresolution based on pixel-level selectivity**, Z. A. Ivanovski, L. Panovski, Ss Cyril and Methodius Univ. (Macedonia); L. J. Karam, Arizona State Univ. [6077-07]

4:50 pm: **Resolution enhancement of low-quality videos using a high-resolution frame**, T. Q. Pham, L. J. van Vliet, Technische Univ. Delft (Netherlands); K. Schutte, TNO-FEL (Netherlands) [6077-08]

SESSION 2

Conv. Ctr. Room B2 Tues. 1:30 to 4:40 pm

Video Coding

Chair: Robert L. Stevenson, Univ. of Notre Dame

1:30 pm: **Predictive fast motion/disparity search for multiview video coding**, P. Lai, A. Ortega, Univ. of Southern California [6077-09]

1:50 pm: **Complexity scalable motion estimation for H.264/AVC**, C. Kim, Univ. of Southern California; J. Xin, A. Vetro, Mitsubishi Electric Research Labs.; C. C. J. Kuo, Univ. of Southern California [6077-10]

2:10 pm: **Depth map compression for unstructured lumigraph rendering**, U. Fecker, A. Guenagues, I. Scholz, A. Kaup, Friedrich-Alexander-Univ. Erlangen-Nürnberg (Germany) [6077-11]

2:30 pm: **Shape adaptive integer transform for coding arbitrarily shaped objects in H264/AVC**, X. Li, E. A. Edirisinghe, H. E. Bez, Loughborough Univ. (United Kingdom) [6077-12]

2:50 pm: **Optimal bit allocation for hybrid scalable/multiple-description video transmission over wireless channels**, M. Bansal, M. K. Jubran, L. P. Kondi, SUNY/Univ. at Buffalo [6077-13]

Coffee Break 3:10 to 3:40 pm

3:40 pm: **Space-time multiple description video coding**, D. Wang, N. Canagarajah, D. Bull, Univ. of Bristol (United Kingdom) [6077-14]

4:00 pm: **Improving sequential decoding of CABAC encoded data via objective adjustment of the complexity-efficiency trade-off**, S. Ben-Jamaa, M. Kieffer, P. Duhamel, Univ. Paris XI (France) and Ctr. National de la Recherche Scientifique (France) [6077-15]

4:20 pm: **New intra-luma prediction mode in H.264/AVC using collocated weighted chroma pixel value**, I. Cho, J. Lee, W. Lee, D. Jeong, Inha Univ. (South Korea) [6077-16]

Conference 6077 • Conv. Ctr. Rooms B2 and B3

✓ Posters and Demonstrations-Tuesday

Demonstrations 5:30 to 8:30 pm

A symposium-wide demonstration session will be open to attendees 5:30 to 8:30 pm Tuesday evening in Conv. Ctr. Exhibit Hall 1. Demonstrators will provide interactive, hands-on demonstrations of a wide-range of products related to Electronic Imaging.

Posters 5:30 to 7:00 pm

Posters will be placed on display after 10:00 am in Exhibit Hall 1. A poster session, with authors present at their posters, will be held Tuesday evening, 5:30 to 7:00 pm.

- ✓ **Coupled nonlinear-diffusion color image sharpening based on the chromaticity-brightness model**, T. Saito, R. Nosaka, T. Komatsu, Kanagawa Univ. (Japan) [6077-56]
- ✓ **Parallel implementation of arbitrary-shaped MPEG-4 decoder for multiprocessor systems**, M. Pastrnak, P. H. N. de With, LogicaCMG (Netherlands) and Technische Univ. Eindhoven (Netherlands); S. Stuijk, J. van Meerbergen, Technische Univ. Eindhoven (Netherlands) [6077-57]
- ✓ **A framework for fast mode decision in the H.264 video coding standard**, M. Y. Yang, C. Grecos, Loughborough Univ. (United Kingdom) [6077-58]
- ✓ **Interpolation of still images using the decay and persistence properties of discrete wavelet transform coefficients**, W. Kwak, R. Park, J. Lee, Sogang Univ. (South Korea) [6077-59]
- ✓ **Optimum computational resource allocation and energy minimization for video encoding on portable devices**, Z. He, Univ. of Missouri/Columbia [6077-60]
- ✓ **Optimal video sensing strategy and performance analysis for wireless video sensors**, Z. He, Univ. of Missouri/Columbia . . [6077-61]
- ✓ **Shot boundary detection using scale invariant feature matching**, M. Park, R. Park, S. W. Lee, Sogang Univ. (South Korea) [6077-62]
- ✓ **Extracting focused object from low depth-of-field image sequences**, J. Park, C. Kim, Information and Communications Univ. (South Korea) [6077-63]
- ✓ **Adaptive de-blocking filter for low bit rate applications**, X. Jin, G. Zhu, Huazhong Univ. of Science and Technology (China) [6077-64]
- ✓ **Fast intra-mode decision algorithm of H.264/AVC**, W. Lee, J. Lee, I. Cho, D. Jeong, Inha Univ. (South Korea) [6077-65]
- ✓ **A splitting algorithm for touched particle based on distance map and particle shape information**, W. Wang, Chongqing Univ. of Posts and Telecommunications (China) [6077-66]
- ✓ **Geo-registration of aerial images by feature matching**, Z. Wu, H. Qian, M. Zhu, Zhejiang Univ. (China) [6077-67]
- ✓ **A new segmentation approach using Gaussian color model and temporal information**, M. Karaman, L. Goldmann, T. Sikora, Technische Univ. Berlin (Germany) [6077-68]
- ✓ **Region-based transform-domain video scrambling**, F. Dufaux, T. Ebrahimi, Emittall S.A. (Switzerland) and École Polytechnique Fédérale de Lausanne (Switzerland) [6077-69]
- ✓ **Robust face detection based on components and their topology**, L. Goldmann, U. Mönich, T. Sikora, Technische Univ. Berlin (Germany) [6077-70]
- ✓ **Resolution scalable SPIHT**, D. Choundappan, P. Salama, M. Rizkalla, M. El-Sharkawy, Indiana Univ./Purdue Univ. at Indianapolis . . [6077-72]

- ✓ **Robust global motion estimation in video stabilization for reducing visually induced motion sickness**, I. Tsubaki, Kanagawa Univ. (Japan); T. Morita, NHK Engineering Services (Japan); K. Aizawa, The Univ. of Tokyo (Japan); T. Saito, Kanagawa Univ. (Japan) [6077-73]
- ✓ **Spatially variant morphological image processing: theory and applications**, N. Bouaynaya, D. Schonfeld, Univ. of Illinois at Chicago [6077-74]
- ✓ **Video frame rate up conversion under inconsistent camera**, J. Wang, Wayne State Univ.; N. Patel, W. Grosky, Univ. of Michigan/ Dearborn [6077-75]
- ✓ **Pre-compression rate allocation for JPEG2000 encoders in power constrained devices**, F. Chebil, R. Kurceren, Nokia Americas [6077-76]
- ✓ **Distortion fluctuation control for 3D wavelet-based video coding**, V. Seran, L. P. Kondi, SUNY/Univ. at Buffalo [6077-77]
- ✓ **Reduction of MPEG ringing artifacts using adaptive sigma filter**, H. Pan, Sharp Labs. of America, Inc. [6077-78]
- ✓ **Bit-stream extraction to maximize perceptual quality using quality information table in SVC**, Y. S. Kim, Y. J. Jung, T. C. Thang, Y. M. Ro, Information and Communications Univ. (South Korea) [6077-79]
- ✓ **Active surfaces for video tracking and 3D segmentation based on a new method for multidimensional optimization**, N. Bouaynaya, D. Schonfeld, Univ. of Illinois at Chicago [6077-80]
- ✓ **Robust transmission of packet-based H.264/AVC video with data partitioning over DS-CDMA wireless channels**, A. V. S. Mantravadi, M. Bansal, L. P. Kondi, SUNY/Univ. at Buffalo [6077-81]
- ✓ **A novel VLC-based on second-run-level coding and dynamic truncation**, C. h. Cui, W. y. Liu, X. Jin, Huazhong Univ. of Science and Technology (China) [6077-82]
- ✓ **Efficient coding scheme for super high definition video based on extending H.264 high profile**, S. Naito, A. Matsumura, KDDI R&D Labs. (Japan) [6077-83]
- ✓ **Fish tracking by combining motion-based segmentation and particle filtering**, E. Bichot, L. Mascarilla, P. Courtellemont, Univ. de La Rochelle (France) [6077-85]
- ✓ **Multiresolution color patch extraction**, P. Obrador, Hewlett-Packard Labs. [6077-86]
- ✓ **Disparity estimation using edge model for stereo video compression**, H. J. Kim, Y. Lee, J. B. Ra, K. Cho, Korea Advanced Institute of Science and Technology (South Korea) [6077-87]
- ✓ **Adaptive estimation in Lagrangian rate-distortion optimization for video coding**, L. Chen, Mobilygen Corp. . . [6077-88]

Conference 6077 • Conv. Ctr. Rooms B2 and B3

Wednesday 18 January

Plenary Speaker Wed. 8:30 to 9:15 am

Marriott Ballroom 1-6

Computational Imaging Methods for Functional Brain Mapping and Molecular Imaging

Richard Leahy, Univ. of Southern California

See p. 7 for details.

Sessions 3 and 6 run concurrently.

SESSION 3

Conv. Ctr. Room B3 Wed. 9:30 am to 12:05 pm

Special Session: Current Topics in Video Coding

Chairs: Mary L. Comer, Purdue Univ.; *Edward J. Delp III*, Purdue Univ.

9:30 am: **Rate-distortion analysis of SP and SI frames (Invited Paper)**, E. Setton, P. Ramanathan, B. Girod, Stanford Univ. [6077-17]

9:55 am: **Wyner-Ziv video coding with universal prediction**, Z. Li, L. Liu, E. J. Delp III, Purdue Univ. [6077-18]

Coffee Break 10:20 to 10:50 am

10:50 am: **Hybrid scalable video coding with multiple description and layered coding (Invited Paper)**, G. Zhang, R. L. Stevenson, Univ. of Notre Dame [6077-19]

11:15 am: **Wyner-Ziv video coding: a motion estimation perspective**, Z. Li, L. Liu, E. J. Delp III, Purdue Univ. [6077-20]

11:40 am: **A new approach to motion compensation in spatially scalable video coding (Invited Paper)**, M. L. Comer, Purdue University [6077-21]

Lunch/Exhibition Break 12:00 to 1:35 pm

SESSION 6

Conv. Ctr. Room B2 Wed. 9:30 am to 12:00 pm

Computer Vision

Chair: Dan Schonfeld, Univ. of Illinois at Chicago

9:30 am: **Parallel multiple target tracking using multiple cooperative trackers**, W. Qu, D. Schonfeld, Univ. of Illinois at Chicago; M. A. Mohamed, Motorola, Inc. [6077-31]

9:50 am: **Rao-Blackwellised particle filter with adaptive system noise and its evaluation for tracking in surveillance**, X. Xu, B. Li, Arizona State Univ. [6077-32]

10:10 am: **Spatial detection of logos as outliers from the content**, A. Ekin, Philips Research Labs. (Netherlands) [6077-33]

Coffee Break 10:30 to 11:00 am

11:00 am: **Finding corners in images by foveated search**, T. L. Arnow, A. C. Bovik, The Univ. of Texas at Austin [6077-34]

11:20 am: **Two-dimensional regularized disparity estimation based on the Gabor transform**, X. Huang, E. Dubois, Univ. of Ottawa (Canada) [6077-35]

11:40 am: **Plane-based calibration of cameras with zoom variation**, C. Yu, G. Sharma, Univ. of Rochester [6077-36]

Lunch/Exhibition Break 12:00 to 2:00 pm

Sessions 4 and 7 run concurrently.

SESSION 4

Conv. Ctr. Room B3 Wed. 1:35 to 3:15 pm

Special Session: Advances in Image/Video Coding and Delivery

Chair: John G. Apostolopoulos, Hewlett-Packard Labs.

1:35 pm: **Distributed sender-driven video streaming (Invited Paper)**, J. Chakareski, P. Frossard, École Polytechnique Fédérale de Lausanne (Switzerland) [6077-22]

2:00 pm: **Advances in video encoder optimization (Invited Paper, Presentation Only)**, A. Dumitras, Apple Computer, Inc. [6077-23]

2:25 pm: **Suprathreshold visual psychophysics and structure-based visual masking (Invited Paper)**, S. S. Hemami, D. M. Chandler, B. Chern, J. A. Moses, Cornell Univ. [6077-24]

2:50 pm: **Video compression with flexible playback order based on distributed source coding (Invited Paper)**, N. Cheung, H. Wang, A. Ortega, Univ. of Southern California [6077-89]

Coffee Break 3:15 to 3:45 pm

SESSION 7

Conv. Ctr. Room B2 Wed. 2:00 to 3:00 pm

Video Processing

Chair: Remco Muijs, Philips Research Labs. (Netherlands)

2:00 pm: **Classification-based hybrid filters for image processing**, H. Hu, Technical Univ. of Eindhoven (Netherlands); G. de Haan, Philips Research Labs. (Netherlands) [6077-37]

2:20 pm: **Solving occlusion in film judder elimination**, E. B. Bellers, Philips Semiconductors; J. van Gurp, Philips Semiconductors (Netherlands); J. Janssen, Philips Semiconductors; R. A. C. Braspenning, R. Wittebrood, Philips Research Labs. (Netherlands) [6077-39]

2:40 pm: **Similarity-independent and non-iterative algorithm for subpixel motion estimation**, M. Shimizu, S. Chang, M. Okutomi, Tokyo Institute of Technology (Japan) [6077-40]

Coffee Break 3:00 to 3:30 pm

Conference 6077 • Conv. Ctr. Rooms B2 and B3

Sessions 5 and 8 run concurrently.

SESSION 5

Conv. Ctr. Room B3 Wed. 3:45 to 5:25 pm

Distributed Source Coding

Chair: Majid Rabbani, Eastman Kodak Co.

- 3:45 pm: **H.264 redundant slices for systematic lossy error protection of video**, S. D. Rane, B. Girod, Stanford Univ. [6077-26]
- 4:05 pm: **Correlation estimation and performance optimization for distributed image compression**, Z. He, Univ. of Missouri/Columbia [6077-27]
- 4:25 pm: **Correlation structure analysis for distributed video compression over wireless video sensor networks**, Z. He, Univ. of Missouri/Columbia [6077-28]
- 4:45 pm: **Distributed multiview video coding**, X. Guo, Harbin Institute of Technology (China) and Microsoft Research Asia (China); Y. Lu, F. Wu, Microsoft Research Asia (China); W. Gao, Institute of Computing Technology (China); S. Li, Microsoft Research Asia (China) and Beijing Institute of Technology (China) [6077-29]
- 5:05 pm: **Free viewpoint switching in multiview video streaming using Wyner-Ziv video coding**, X. Guo, Harbin Institute of Technology (China); Y. Lu, F. Wu, Microsoft Research Asia (China); W. Gao, Institute of Computing Technology (China); S. Li, Microsoft Research Asia (China) [6077-30]

SESSION 8

Conv. Ctr. Room B2 Wed. 3:30 to 4:30 pm

Image Coding

Chair: William A. Pearlman, Rensselaer Polytechnic Institute

- 3:30 pm: **A wavelet-based two-stage near-lossless coder with L-infinity error scalability**, S. Yea, W. A. Pearlman, Rensselaer Polytechnic Institute [6077-41]
- 3:50 pm: **Region of interest access with three-dimensional SBHP algorithm**, Y. Liu, W. A. Pearlman, Rensselaer Polytechnic Institute [6077-42]
- 4:10 pm: **Optimal JPEG2000 rate control mechanism applicable for super low delay distribution of HDTV programs**, S. Naito, A. Koike, Kokusai Dinshin Denwa KK (Japan) [6077-43]

Thursday 19 January

SESSION 9

Conv. Ctr. Room B3 Thurs. 9:30 to 11:40 am

Media over Networks

Chair: Paul Salama, Indiana Univ./Purdue Univ. at Indianapolis

- 9:30 am: **Error resilience in network driven Wyner-Ziv video coding**, L. Liu, P. Sabria, Purdue Univ.; J. Prades-Nebot, Univ. Politècnica de València (Spain); E. J. Delp III, Purdue Univ. [6077-45]
- 9:50 am: **Receiver buffer requirement for video streaming over TCP**, T. Kim, Freescale Semiconductor, Inc.; M. H. Ammar, Georgia Institute of Technology [6077-46]
- 10:10 am: **Effective overlay multicast tree constructing algorithm over multiple differentiated-service networks**, D. B. Lee, H. Song, Pohang Univ. of Science and Technology (South Korea) [6077-47]
- Coffee Break 10:30 to 11:00 am
- 11:00 am: **A novel source rate control algorithm for video streaming over the Internet**, Z. Peng, Tsinghua Univ. (China); W. Zeng, Univ. of Missouri/Columbia; C. W. Li, Tsinghua Univ. (China) [6077-48]
- 11:20 am: **Motion-embedded residual error for packet loss recovery of video transmission and encryption**, S. Sun, Institute of Information Science (Taiwan); J. Chen, National Central Univ. (Taiwan); C. Lu, Institute of Information Science (Taiwan); P. Chang, K. Fan, National Central Univ. (Taiwan) [6077-49]
- Lunch Break 11:40 am to 1:30 pm

SESSION 10

Conv. Ctr. Room B3 Thurs. 1:30 to 3:10 pm

Scalable Video Coding

Chair: John W. Woods, Rensselaer Polytechnic Institute

- 1:30 pm: **A new structure of 3D dual-tree discrete wavelet transforms and applications to video denoising and coding**, F. Shi, B. Wang, I. W. Selesnick, Y. Wang, Polytechnic Univ. [6077-50]
- 1:50 pm: **On scalable lossless video coding based on subpixel accurate MCTF**, S. Yea, W. A. Pearlman, Rensselaer Polytechnic Institute [6077-51]
- 2:10 pm: **Aliasing reduction via frequency roll-off for scalable image/video coding**, Y. Wu, J. W. Woods, Rensselaer Polytechnic Institute [6077-52]
- 2:30 pm: **Adaptive in-band motion compensated temporal filtering based on motion mismatch detection in the high-pass subbands**, A. Gao, N. Nanagarajah, D. Bull, Univ. of Bristol (United Kingdom) [6077-53]
- 2:50 pm: **Quality-fluctuation-constrained rate allocation for MCTF-based video coding**, Y. Chen, Shanghai Jiao Tong Univ. (China); J. Xu, F. Wu, Microsoft Research Asia (China); H. Xiong, Shanghai Jiao Tong Univ. (China) [6077-54]

Participants

- A**
Aach, Til [6064A ProgComm
Abdelzaher, Tarek F. 6071
ProgComm
Abdul Halim, Izhal [6056-04]S1
Abe, Hideshi [6068-11]S2
Abe, Sachiko [6062-13]S4
Abidi, Mongi A. [6070-09]S2
Abu-Hajar, Ahmed F.
[6060-13]S6
Aburdene, Maurice F.
[6064A-12]S2, [6064A-39]S7
Adameck, Markus
[6070-05]S2
Adams, Chris [6068-03]S1
Adams, Michael Review
Adjeroth, Donald A.
[6064A-47]S7
Adve, Sarita V. 6071
ProgComm
Agaian, Sos S. 6064A
ProgComm, [6064A-09]S2,
[6064A-28]S6, [6072-26]S6,
[6074-18]S8
Agam, Gady 6066
ProgComm, [6067-23]S7
Agar, A. Ufuk 6058
ProgComm, 6058 S6
SessChr
Agarwalla, Bikash
[6071-07]S2
Aguilera, Julieta C.
[6055B-72]S15
Agutter, Jim Review,
[6060-24]S11
Ahmad, Iftikhar [6074-09]S5
Ahmed, Mohamed N.
[6064B-52]S8
Ahmed, Nova [6071-07]S2
Ahn, Choonhyun
[6074-36]S12
Ahn, Chungyun
[6055A-59]S13,
[6074-37]S12, [6074-40]S12
Ahumada, Albert J. 6057
ProgComm, [6057-30]S8
Aizawa, Kiyoharu 6073
ProgComm, [6073-13]S4,
6077 ProgComm,
[6077-73]S11
Ajemba, Peter O. [6056-25]S5
Akarun, Lale [6064B-54]S9
Akatsuka, Shiro [6072-20]S4
Akil, Mohamed 6063
ProgComm, 6063 S4
SessChr, [6063-17]S4,
[6063-18]S4
Akkermans, Ton H.
[6072-19]S4
Akopian, David 6074
ProgComm, 6074 S10
SessChr, [6074-18]S8
Al Bawab, Ziad [6067-24]S8
Alam, Mohammad S.
[6064A-14]S3
Alattar, Adnan M. 6072
ProgComm, 6072 S10
SessChr, [6072-63]S14
Alattar, Osama M.
[6072-63]S14
Alberdi, Coro [6062-02]S1
Aldershoff, Frank [6061-16]S6
Alecu, Corina [6062-06]S2
Aleksic, Milivoje [6069-13]S3,
[6069-15]S4
Alfonso, Santiago
[6062-02]S1
- Alfredson, Jens [6057-29]S7
Ali Salah, Albert [6064B-54]S9
Aliaga, Daniel G. [6065-22]S7
Al-Jarrah, Inad [6056-13]S3
Allberg, Henrik U. [6057-29]S7
Allebach, Jan P. 6057
ProgComm, 6058
ProgComm, 6058 S7
SessChr, [6059-13]S5,
[6059-27]S8, [6072-36]S8,
6076 Chr, [6076-11]S3,
[6076-13]S3, [6076-14]S3
Allili, Madjid [6066-01]S1
Alpaslan, Zahir Y.
[6055A-13]S3
Alquié, Georges [6058-37]S8
Altun, Oktay [6065-24]S7
Altunbasak, Yucl 6077
ProgComm, [6077-05]S1
Alvarez, Evelyn E.
[6055B-78]S16
Alvarez, Luis [6077-25]S1
Alvarez-Diaz, Marcos
[6072-12]S3
Amidor, Isaac [6075-28]S7
Ammar, Hany H.
[6064A-26]S5, [6064A-47]S7
Ammar, Mostafa H.
[6077-46]S9
An, Xiaobo [6066-13]S4
Anantrasrichai, Nantheera
[6055A-52]S13
Andersen, Tim L. 6067
ProgComm, [6067-05]S3
Anderson, James G. 6066 S6
SessChr, [6066-12]S4,
[6066-30]S8, [6066-31]S8
Andra, Srinivas [6067-07]S3,
[6067-25]S8
Andreea, Morgan [6063-07]S2
Andrews, Keith Review
Andrews, Kevon [6073-03]S1
Andriacchi, Thomas P.
[6056-28]S5
Aner-Wolf, Aya 6073
ProgComm
Annen, Thomas [6055A-24]S6
Ansari, Rashid [6072-70]S16
Antani, Sameer K.
[6061-22]S7, [6076-03]S1
Antonacopoulos, Apostolos
6067 ProgComm
Anwar, Zahid [6071-02]S1
Aoki, Soko [6055A-41]S12
Aoki, Terumasa [6073-10]S3
Apostolopoulos, John G.
6077 Chr, 6077 S4 SessChr
Appell, Charles SC765 Inst
Aradhye, Hrishikesh B.
[6067-10]S4
Arai, Jun [6055A-36]S9
Araki, Kazuo [6056-29]S6,
[6056-34]S6
Araki, Yasushi [6068-12]S2
Arasanathan, Anjulana
[6073-24]S7
Arce, Gonzalo R. [6057-11]S4,
[6058-39]S8
Argamon, S. [6067-23]S7
Argoitia, Alberto [6075-24]S6
Arias-Estrada, Miguel O.
[6063-31]S5
Arjona, Montserrat
[6062-15]S4
Armstrong, Andrew J.
[6074-03]S3
Arnabat, Jordi [6075-07]S3
- Arnauts, Stephan
[6064A-27]S6
Arnou, Thomas L.
[6077-34]S6
Aronoff, Jason S. [6075-07]S3
Asano, Toshiro [6056-32]S6
Asari, Vijayan K. [6063-19]S5,
[6064A-32]S6,
[6064A-44]S7,
[6064B-57]S10
As-Sadhan, Basil [6067-24]S8
Astola, Jaakko T. SC761 Inst,
6064A Chr
Atallah, Mikhail J. [6072-10]S2
Atkins, Clayton B.
[6076-06]S1
Atmani, Hakim [6070-26]S7
Atsumi, Eiji 6069 ProgComm
Aubretton, Olivier [6070-14]S4
Augusto, Costantini
[6065-43]S12
Auslander, Judith [6075-37]S4
Autrusseau, Florent
[6057-08]S4
Avila, Lisa Review
Aviles, Ivelisse [6057-17]S6
Aykac, Deniz [6070-18]S4
Aymeric, David [6064A-27]S6
Ayres, Fabio J. [6064A-07]S1
Azuma, Shizuka [6060-17]S8
- B**
Babaeizadeh, Saeed
[6065-25]S8
Babaguchi, Noboru 6073
ProgComm, [6073-06]S2
Babu, Pavithra [6067-02]S1
Bacca Rodriguez, Jan
[6057-11]S4, [6058-39]S8
Backman, Nathan J.
[6065-48]S12
Bäckström, Christer H.
[6073-25]S8
Bae, Byungjun
[6055A-59]S13,
[6074-36]S12
Bae, Kyung-Hoon
[6066-29]S8
Bae, Tae Meon [6074-06]S3
Baer, Richard L. [6068-05]S1
Baird, Henry S. [6067-27]S8
Bajcsy, Peter Review
Baker, Chris [6056-10]S3
Bal, Abdullah [6064A-14]S3
Bala, Raja [6065-38]S10
Balado, Felix [6072-30]S7,
[6072-31]S7, [6073-04]S2
Balakrishnan, Nikhil
[6065-23]S7
Balasubramanian, Raman
[6066-24]S7
Baldi, Pierre 6064B
ProgComm
Baldwin, Kevin [6056-14]S3
Balinsky, Helen [6076-09]S2
Baloch, Sajjad [6065-05]S2
Balogh, Tibor [6055A-29]S7
Baloukas, Bill [6075-42]S10
Bang, Yousun [6058-26]S6
Banghart, Edmund K.
[6069-02]S1
Banks, David C. Review,
[6060-11]S5, [6060-12]S5,
[6060-18]S8
Bansal, Manu [6077-13]S2,
[6077-81]S11
- Baone, Gaurav A.
[6062-10]S4
Baraniuk, Richard G.
[6065-09]S3
Bares, Jan 6058 ProgComm
Baritz, Mihaela I.
[6057-42]S13
Barland, Rémi [6059-05]S2
Barney Smith, Elisa H.
[6059-14]S5, 6067
ProgComm, [6067-05]S3
Barni, Mauro [6057-32]S8,
6072 ProgComm, 6072 S16
SessChr, [6072-25]S6,
[6072-27]S7
Baron, Dror [6065-09]S3
Barrera, Junior 6064A
ProgComm
Barrett, Eamon B.
[6065-17]S5
Barrett, Steven F. [6068-16]S3
Barrie, Bertrand [6063-05]S2
Barsky, Brian A. [6069-17]S4,
[6070-30]S7
Barth, Erhardt [6057-49]S3
Bartz, William J. [6075-04]S2
Basaldella, Daniele
[6073-05]S2
Baskurt, Atilla M.
[6064A-22]S4, [6072-50]S12
Bastani, Behnam [6058-22]S5
Basu, Samit [6065-34]S9
Battiato, Sebastiano
[6061-29]S9, [6064A-34]S7
Baugh, Carlton [6055A-05]S1
Baum, Geoffrey A.
[6055B-79]S16
Baumgartner, Jason Review
Bazen, Asker M. [6072-65]S4
Beason, Kevin M.
[6060-11]S5, [6060-12]S5
Bebek, Christopher J.
[6068-35]S3
Bechamp, Marc
[6055A-44]S12
Becherer, Nico [6065-12]S4
Becker, Barry G. Review
Beckley, Russell [6067-19]S6
Beesley, Steven T.
[6074-03]S3
Bei, Yun [6061-14]S5
Bellers, Erwin B. [6077-39]S7
Bellis, Stephen [6068-15]S3
Belmamoune, Mounia
[6061-14]S5
Ben Chouikha, Mohamed
[6058-37]S8
Bender, Walter R. 6057
ProgComm
Benesova, Wanda
[6070-21]S5
Ben-Ezra, Moshe [6077-04]S1
Benger, Werner Review
Bengio, Yoshua 6064B
ProgComm
Beniyama, Fumiko
[6055A-35]S9
Ben-Jamaa, Salma
[6077-15]S2
Bennour, Jihane [6072-61]S14
Benoit, Mathieu [6061-13]S5
Bentabet, Layachi
[6064A-02]S1, [6066-01]S1
Bentley, Jon L. [6067-17]S5
Berche, Stéphane
[6058-37]S8
Berentsen, Jelle [6059-09]S3
- Beretta, Giordano B.
[6061-10]S4
Berezney, Ronald [6066-07]S3
Bergamasco, Massimo
[6055A-02]S1
Bergeron, Dan Review
Berkner, Kathrin 6076
ProgComm, 6076 S3
SessChr, [6076-17]S4
Bernal, Edgar [6059-27]S8
Berndt, Dirk [6070-19]S5
Berns, Roy S. 6062
ProgComm
Berretty, Robert-Paul M.
[6055A-22]S6
Berriel-Valdos, Luis R.
[6064A-48]S7
Berroqui, Miguel [6062-02]S1
Bertetti, Massimiliano
[6056-26]S5
Bertini, Enrico [6060-21]S10
Bertrand, Gilles 6066
ProgComm
Bethel, Edward W.
[6061-12]S4
Beyer, Dirk [6076-06]S1
Beyer, James C. [6071-15]S5
Bez, Helmut E. [6077-12]S2
Bhandarkar, Suchendra M.
[6071-20]S5
Bhatia, Rimple [6075-18]S5
Bhole, Chetan [6067-02]S1
Bi, Sheng [6057-41]S13
Bichong, Elodie [6077-85]S11
Bilasco, Ioan Marius
[6073-34]S4
Binczak, Stéphane
[6070-20]S5
Birkholz, Hermann
[6055B-63]S13
Bischof, Horst [6070-21]S5
Björke, Kevin A. [6065-41]S11
Black, John A. [6057-39]S13
Blanco, Wilfredo [6060-18]S8
Bleeker, Julian
[6055B-76]S16
Blin, Jean-Louis [6057-20]S6
Bloom, Jeffrey A. 6072
ProgComm
Blouke, Morley M. 6068 Chr
Blundell, Benjamin J.
[6060-08]S3
Bocchino, Robert [6071-02]S1
Bocko, Mark [6065-24]S7
Bodegom, Erik 6068
ProgComm
Boeszoermyenyi, Laszlo
[6071-12]S3
Boggs, Kasey L. [6068-17]S3,
[6068-21]S3
Böhme, Martin [6057-49]S3
Böhme, Rainer [6072-06]S1
Bolas, Mark T. 6055B Chr,
6055B S15 SessChr, 6055B
S16 SessChr
Bonacini, Daniele [6056-26]S5
Boncelet, Charles G. Review,
[6072-07]S1
Bonifazi, Giuseppe
[6064A-15]S3, [6065-43]S12
Bonifazzi, Claudio
[6062-22]S6
Boosmann, Thomas
[6062-17]S5
Borgeat, Louis [6055A-15]S4

Participants

Borges da Costa, José Ant6nio T. [6064A-24]S5
 Borland, David M. [6060-04]S2
 B6rner, Katy 6060 Chr, 6060 S8 SessChr, [6060-36]S15
 Borovikov, Eugene [6067-12]S4
 Borsack, Julie [6067-19]S6
 Bosiers, Jan T. [6068-34]S3
 Bossu, J6r6mie [6070-23]S5
 Bouaynaya, Nidhal [6077-74]S11, [6077-80]S11
 Bouquet, Jean-Yves [6061-01]S1
 Boujemaa, Nozha 6073 ProgComm, [6073-16]S5
 Bourman, Charles A. SympChair, [6058-28]S6, 6065 S1 SessChr, 6065 Chr, [6065-02]S2, [6065-33]S9, 6076 ProgComm
 Bourgeat, Pierrick T. 6070 ProgComm
 Bouteldja, Nouha [6073-09]S3
 Boutin, Fran6ois [6060-26]S12
 Boutin, Mireille 6065 S7 SessChr, [6065-22]S7
 Bouwer, James C. [6068-26]S4
 Bouzit, Samira [6059-04]S2
 Bovik, Alan C. 6077 ProgComm, [6077-34]S6
 Boyd, Jeffrey E. 6061 ProgComm, [6061-30]S10
 Brady, David J. [6065-15]S5
 Braginets, Eugene V. [6075-26]S6, [6075-29]S7, [6075-41]S10
 Brailsford, David F. 6076 ProgComm, [6076-20]S5
 Brambilla, Carla [6061-10]S4
 Brandes, Ulrik [6060-23]S10
 Brandt, Scott A. 6071 ProgComm
 Brankov, Jovan G. [6065-28]S8, [6065-32]S9
 Braspenning, Ralph A. C. [6055A-20]S5, [6077-39]S7
 Braudaway, Gordon W. 6072 ProgComm, 6072 S14 SessChr, [6076-15]S3
 Bredthauer, Richard A. [6068-17]S3
 Brennan, Michelle [6057-17]S6
 Breuel, Thomas M. [6058-03]S1
 Brill, Michael H. 6057 ProgComm
 Brinkschulte, Uwe 6060 ProgComm
 Brodersen, Joerg [6063-14]S4
 Brodie, Ken Review
 Brooks, Alan [6057-22]S6
 Brooks, Dana H. [6065-25]S8
 Brotherton, Matthew D. [6057-19]S6, [6057-40]S13
 Brown, Adrian J. [6062-01]S1
 Brown, Michael S. Review
 Browse, Roger A. [6057-33]S8
 Bruna, Arcangelo [6069-12]S3
 Brunnstr6m, Kjell [6057-19]S6
 Bruno, Eric [6073-33]SA
 Bryant, Emily [6062-06]S2
 Buckingham Shum, Simon J. Review
 Bull, David [6077-14]S2, [6077-53]S10
 Bullitt, Julian [6059-25]S8
 Bulusu, Nirupama [6071-19]S5
 Burch, Michael [6060-25]S12
 Burke, Barry E. [6068-18]S3
 Burns, Peter SC513 Inst, 6059 S5 SessChr, 6059 ProgComm, [6059-21]S7, [6059-22]S7
 B6ttgen, Bernhard [6056-03]S1
C
 Cadek, Gerhard [6063-14]S4
 Caelli, Terry M. 6064B ProgComm
 Caffisch, Luca [6061-36]S7
 Caglayan, Okan [6064A-09]S2
 Cai, Lilong [6056-02]S1
 Cai, Wei-guang [6074-42]S12
 Cambriani, Luigi [6070-12]S3
 Cameron, Marietta Review
 Campbell, Roy H. [6071-02]S1
 Campisi, Patrizio [6064A-43]S7
 Canagarajah, Nishan [6073-24]S7, [6077-14]S2, [6077-53]S10
 Canarajah, Nishan [6055A-52]S13
 Cancelli, Giacomo [6072-25]S6
 Cannon, David [6057-17]S6
 Canny, John F. [6061-17]S6
 Carcagni, Pierluigi [6062-22]S6
 Cardinal, Jean [6071-04]S1
 Carletta, Joan E. [6064A-31]S6
 Carli, Marco [6059-40]S11, [6064A-23]S5
 Carlsohn, Matthias F. 6063 ProgComm
 Carnegie, Dale A. [6068-22]S4
 Carney, Thom [6057-53]S10
 Carpendale, M. Sheelagh T. Review, [6060-07]S3
 Carrozzino, Marcello [6055A-02]S1
 Cassol, Gustavo L. F. [6064A-17]S3
 Casta6o Moraga, Carlos Alberto [6064A-19]S4
 Castillo-Jimenez, Liz N. [6063-31]S5
 Castro, Rui [6065-07]S3
 Castro-Pareja, Carlos R. 6063 S2 SessChr, 6063 ProgComm, [6063-01]S1, [6063-25]S5
 Catrysse, Peter B. [6069-04]S1
 Cecchi, Guillermo A. [6057-26]S7, [6064B-60]S10
 Celenk, Mehmet [6056-13]S3
 Celik, Mehmet U. [6072-42]S10
 Ceron-Correa, Alexander [6062-04]S2
 Chakareski, Jacob [6077-22]S4
 Chalmers, Alan 6074 ProgComm
 Chalumeau, Thomas [6070-31]S7
 Chambah, Majed [6059-28]S9
 Chandler, Damon M. [6057-07]S4, [6077-24]S4
 Chandra, Surendar 6071 Chr, 6074 ProgComm
 Chang, Benjamin [6055B-79]S16
 Chang, Cheng-Wei B. [6061-02]S1
 Chang, Edward Y. [6061-02]S1, 6073 S7 SessChr, 6073 Chr, [6073-40]S
 Chang, Eun-Young [6061-35]S10
 Chang, Pao-Chi [6077-49]S9
 Chang, Shih-Fu [6072-37]S8
 Chang, SoonKeun [6077-40]S7
 Chao, Hui [6067-14]S5, 6076 Chr, [6076-06]S1, [6076-18]S4
 Chao, Shi C. [6058-43]S9
 Chapman, Dean [6065-32]S9
 Chapman, Glenn H. [6059-33]S10, [6068-04]S1
 Chassery, Jean-Marc [6072-69]S16
 Chattopadhyay, Siddhartha [6071-20]S5
 Chaudhari, Ajit M. [6056-28]S5
 Chebil, Fehmi [6077-76]S11
 Cheeniylil, Lakshmi Kutty [6076-05]S1
 Cheikh, Faouzi A. [6074-09]S5
 Chellappilla, Kumar H. [6067-26]S8
 Chellappa, Rama [6056-28]S5, 6064B ProgComm
 Chen, Arbee L. P. 6073 ProgComm
 Chen, Chang Wen 6074 Chr, 6074 S3 SessChr, [6074-02]S2, 6077 ProgComm
 Chen, Chao-Yeh [6069-11]S3
 Chen, Chi Y. [6058-43]S9
 Chen, Chien-Chung [6057-01]S2
 Chen, Deyun [6058-42]S9
 Chen, Dongbin [6064A-46]S7
 Chen, Hong Review, [6060-19]S9
 Chen, Hsin-Chia [6070-17]S4
 Chen, Hua-Mei [6064A-29]S6
 Chen, I-Hsien [6066-10]S3
 Chen, Jan-Ru [6077-49]S9
 Chen, Jerry [6061-12]S4
 Chen, Kai [6071-05]S1
 Chen, Keming [6074-15]S6
 Chen, Lihui [6063-11]S3
 Chen, Lulin [6077-88]S11
 Chen, Philip C. 6060 ProgComm
 Chen, Qian [6059-38]S11
 Chen, Quincy [6068-23]S4
 Chen, Tieling [6064A-20]S4
 Chen, Ting-Ju [6075-16]S4
 Chen, Tsuhan 6073 ProgComm
 Chen, Yihua [6077-54]S10
 Chen, Yung-Sheng [6070-28]S7
 Chen, Zhiqiang [6065-35]S9
 Cheng, Hung-Ming [6065-13]S4
 Cheng, Janice Y. [6068-23]S4
 Cheng, Jing [6061-22]S7
 Cheng, Jun [6056-01]S1, [6070-03]S1, [6070-25]S6
 Cheng, Wai K. [6063-07]S2
 Cherifi, Hocine [6057-20]S6
 Cherkasova, Ludmila [6071-18]S5
 Chern, Bobbie [6077-24]S4
 Cheung, Ngai-Man [6077-89]S4
 Chiang, Pei-Ju [6072-36]S8
 Chihara, Kunihiro [6062-08]S3
 Chikando, Aristide [6065-27]S8
 Chirravuri, Srikanth K. [6071-15]S5
 Chiu, George T. C. [6065-13]S4, [6072-36]S8
 Chiueh, Tzi-cker [6071-24]S6
 Cho, Ik-Hwan [6077-16]S2, [6077-65]S11
 Cho, Jun Ho [6061-32]S10
 Cho, Kyunghwan [6077-87]S11
 Cho, Minki [6058-06]S1, [6058-24]S6
 Cho, Sammo [6074-37]S12
 Cho, Seong-Woo [6055A-54]S13
 Cho, Sukhee [6055A-49]S13, [6055A-59]S13
 Cho, Yang-Ho [6058-19]S5
 Choe, Jihwan [6059-06]S2
 Choe, Wonhee [6057-34]S13, [6058-15]S4
 Choh, Heuikun [6058-24]S6
 Choh, Heui-Keun [6058-06]S1, [6058-26]S6
 Choi, Heejin [6055A-37]S9, [6055A-54]S13
 Choi, Hyunsoo [6059-06]S2
 Choi, Kai San [6069-19]S5
 Choi, Kyu Nam [6066-03]S1
 Choi, Tae-Sun [6056-08]S2
 Choo, Chang Y. 6064B ProgComm
 Chosson, Sylvain [6075-28]S7
 Choundappan, Dayanand [6077-72]S11
 Christel, Michael G. 6073 S5 SessChr, [6073-21]S6
 Chu, Failop [6069-03]S1
 Chua, TatSeng 6073 ProgComm
 Chuang, John [6071-06]S2
 Chun, Won-Suk [6055A-38]S10
 Chung, Ginmo [6065-19]S6
 Chung, Michael [6076-03]S1
 Chung, Ronald C. [6056-01]S1, [6070-03]S1, [6070-04]S1, [6070-25]S6
 Chung, Shinil [6055A-62]S13
 Church, Sara E. 6075 ProgComm, 6075 S1 SessChr, [6075-05]S2
 Cignoni, Paolo Review
 Cinar, Hatice [6064B-54]S9
 Cittadini, Ferruccio [6058-37]S8
 Clark, Robert [6056-16]S3
 Clarke, John P. [6060-04]S2
 Clarke, Michele L. [6064B-69]S6
 Claypool, Kajal [6071-01]S1
 Claypool, Mark [6071-01]S1
 Cohen, Jonathan [6056-14]S3
 Colombo, Alessandro [6061-36]S7
 Colombo, Giorgio [6056-26]S5
 Coltuc, Dinu [6072-69]S16
 Comer, Mary L. 6077 S3 SessChr, [6077-21]S3
 Comesana Alfaro, Pedro [6072-14]S3, [6072-32]S7
 Compton, John [6069-03]S1
 Connah, David R. [6070-06]S2
 Conner, William G. [6071-13]S3
 Coombs, Jeffrey S. [6067-19]S6
 Coombs, Paul G. [6075-17]S5
 Cooper, Brian E. [6064B-52]S8
 Cooper, Michael J. [6068-18]S3
 Cooper, Ted J. 6069 ProgComm
 Coppola, Stephen [6069-03]S1
 Corazza, Stefano [6056-28]S5
 Corazzi, Daniele [6072-27]S7
 Cordery, Robert A. [6075-10]S3, [6075-37]S4
 Corner, Brian D. 6056 S1 SessChr, 6056 S2 SessChr, 6056 S5 SessChr, 6056 Chr
 Coulier, Stefaan [6057-15]S5
 Courtellemont, Pierre [6077-85]S11
 Cowan, James J. [6075-25]S6
 Cox, Ingemar J. 6072 ProgComm
 Crampes, Michel [6071-03]S1
 Craver, Scott A. 6072 S5 SessChr, [6072-22]S5
 Crawfis, Roger Review
 Crawford, Clark [6060-41]S15
 Cree, Michael J. [6068-22]S4
 Creusere, Charles D. 6077 ProgComm
 Creutzburg, Reiner 6064A ProgComm, 6074 Chr, 6074 S8 SessChr, 6074 S2 SessChr
 Criado, Enrique [6055A-04]S1
 Crisler, Kenneth J. 6074 ProgComm
 Crisostomo-Romero, Pedro [6063-08]S2
 Crivelli, Silvia N. [6060-41]S15
 Cudahy, Thomas J. [6062-01]S1
 Cui, Chun hui [6077-82]S11
 Cui, Luke C. 6059 Chr, 6059 S1 SessChr
 Cui, Qingguang [6060-27]S12
 Cui, Yi [6071-02]S1
 Cusano, Claudio [6061-36]S7
 Cutu, Florin Review
 Cvek, Urska Review
D
 da Fontoura Costa, Luciano F. 6063 ProgComm
 da Fontoura Costa, Luciano 6070 ProgComm

Participants

da Fontoura Costa, Luciano F. [6070-31]S7
 Da Rugna, Jerome [6057-35]S13
 Dabov, Kostadin [6064A-18]S4, [6064A-30]S6
 Dairiki, Takeshi [6055A-32]S8, [6055A-56]S13
 Dalal, Edul N. [6059-19]S6
 Dalkilic, Memo Review
 Dalton, John C. 6057 ProgComm
 Daly, Scott J. 6057 Chr, [6057-03]S2
 Damaa, Feissal [6071-01]S1
 Dambreville, Samuel [6064B-49]S7, [6064B-51]S7
 Danesi, Cristiane C. [6064A-24]S5
 Dang, Philip P. 6063 ProgComm, [6063-13]S4
 Dantes, Didier G. [6068-08]S2
 D'Apuzzo, Nicola [6056-05]S2
 Darlagiannis, Vasilios [6071-23]S6
 Davies, Robert L. [6073-30]S9
 Davis, Marc [6061-17]S6
 Davison, Brian D. 6067 ProgComm
 Dawson, Robin M. 6068 ProgComm
 de Alencar Lotufo, Roberto [6064A-17]S3
 de Andrade Lopes, Alneu [6060-28]S13, [6060-29]S13
 De Antonio, Angélica A. [6055B-78]S16
 de Bodard de la Jacopiere, Alette [6067-21]S6
 de Haan, Gerard 6077 ProgComm, 6077 S7 SessChr, [6077-37]S7
 de Heij, Hans A. M. [6075-01]S1
 de Hoop, Maarten V. [6065-01]S1
 De Keukelaere, Frederik [6074-23]S10
 de la Rosa Miranda, Enrique [6064A-48]S7
 de Lasarte, Marta [6062-15]S4
 De Man, Bruno [6065-34]S9
 de Oliveira, Maria Cristina F. Review
 de Ridder, Huib 6057 ProgComm
 De Rosa, Alessia [6072-27]S7
 de With, Peter H. N. [6055A-19]S5, [6073-02]S1, [6073-26]S8, [6077-57]S11
 De Zutter, Saar [6074-23]S10
 Debrunner, Chris H. [6056-10]S3
 Decker, Stephen K. [6075-10]S3
 Deguillaume, Frederic [6072-38]S9, [6072-49]S12, [6073-32]S4
 Deinhammer, Harald [6075-03]S1
 Del Bimbo, Alberto 6061 ProgComm
 Delaigle, Jean-François [6056-12]S3, [6063-05]S2
 Delest, Maylis Review
 Dell'Aquila, Luigi [6060-21]S10
 Delp, Edward J. SC084 Inst, [6065-21]S7, 6072 Chr, [6072-09]S2, [6072-36]S8, [6072-47]S11, [6072-58]S13, [6072-58]S13, [6072-59]S13, [6073-14]S4, [6074-08]S5, 6077 ProgComm, 6077 S3 SessChr, [6077-18]S3, [6077-20]S3, [6077-45]S9
 Delpha, Claude [6072-29]S7
 Denney, Thomas S. 6065 ProgComm, 6065 S5 SessChr, [6065-14]S5
 Depalov, Dejan [6057-28]S7
 Der, Sandor Z. 6064B ProgComm
 Derdar, Salah [6066-21]S6
 Derefeldt, Gunilla A. M. 6057 ProgComm, [6057-29]S7
 Derhak, Maxim W. [6062-20]S5
 Derthick, Mark Review
 Deshpande, Sachin G. [6061-24]S8
 Desurmont, Xavier [6056-12]S3, 6063 ProgComm, 6063 S3 SessChr, [6063-05]S2
 Di, Lai [6059-16]S5
 Di Blasi, Giampiero [6064A-34]S7
 Di Blasi, Giampiero [6061-29]S9
 Di Iorio, Angelo [6061-28]S9, [6076-22]S5
 DiCarlo, Jeffrey M. 6062 ProgComm, 6069 Chr, 6069 S3 SessChr
 Diehl, Stephan [6060-25]S12
 Dikici, Cagatay [6072-50]S12
 Dillen, Bart G. M. [6068-34]S3
 Diñeiro, José Manuel [6062-02]S1
 Ding, Xiaoqing [6056-24]S4, 6067 ProgComm, [6067-13]S4, [6067-16]S5
 Dittmann, Jana SC084 Inst, 6072 ProgComm, 6072 S13 SessChr, [6072-54]S13, [6072-56]S13, [6073-17]S5, [6074-30]S11
 Divakaran, Ajay 6073 ProgComm, 6073 S6 SessChr, [6073-01]S1, [6073-18]S6, [6073-20]S6
 DiVerdi, Stephen [6055A-45]S12
 Dlay, Satnam S. [6060-14]S6
 Dmitriev, Ury A. [6068-32]S
 Dodgson, Neil A. 6055A Chr, 6055A S6 SessChr, 6055A S13 SessChr, [6055A-25]S7
 Doermann, David S. 6067 ProgComm, [6067-09]S4, [6067-11]S4, 6074 ProgComm
 Doerschuk, Peter C. 6065 ProgComm, 6065 S4 SessChr, [6065-10]S4, [6065-16]S5
 Doets, Peter J. [6072-21]S5
 Doi, Motonori [6062-05]S2
 Dolinsky, Margaret [6055B-71]S15
 Doloc-Mihu, Anca [6061-20]S7
 Dong, Chaohua [6064B-63]S11
 Dong, Mei [6070-04]S1
 D'Onofrio, Salvatore [6072-67]S15
 Donohue, Kevin D. [6059-15]S5, [6059-20]S6
 Dorai, Chitra 6073 ProgComm
 d'Ornellas, Marcos C. [6064A-24]S5
 Dorr, Michael [6057-49]S3
 Dorrington, Adrian A. [6068-22]S4
 Dougherty, Edward R. 6063 ProgComm, 6064A Chr, 6064B ProgComm
 Doyle, Erika [6073-27]S8
 Draijer, Ceas [6068-34]S3
 Drinkwater, Robb [6055B-79]S16
 D'Souza, Sunil [6074-18]S8
 Du, David H. 6071 ProgComm, [6071-15]S5
 Duarte, Marco [6065-09]S3
 Dubé, Martin [6059-01]S1
 Dubois, Eric 6077 ProgComm, [6077-35]S6
 Dudas, Jozsef [6059-33]S10
 Dufaux, Frederic SC766 Inst, 6077 ProgComm, [6077-69]S11
 Dugelay, Jean-Luc [6072-61]S14
 Duhamel, Pierre [6072-29]S7, [6072-71]S16, [6077-15]S2
 Dulong, Carole [6061-01]S1
 Dumitras, Adriana [6077-23]S4
 Dummann, Uwe 6074 ProgComm
 Duncan, Donald [6056-14]S3
 Dunn, Douglas S. [6075-15]S4
 Durante, Elsa [6067-14]S5
 Durdle, Nelson G. [6056-25]S5
 Duric, Zoran [6072-23]S6
 Duta, Sorin A. [6064A-21]S4
 Dutagaci, Helin [6072-18]S4
 Duttweiler, Fred [6068-26]S4
 Dykstra-Erickson, Elizabeth 6074 ProgComm
E
 Ebert, David S. Review, [6065-21]S7
 Ebrahimi, Touradj SC766 Inst, 6077 ProgComm, [6077-69]S11
 Eckel, Christian [6063-14]S4
 Eckstein, Miguel P. 6057 ProgComm
 Edirisinghe, Eran A. [6077-12]S2
 Edlich, Stefan 6074 S5 SessChr, [6074-25]S10, [6074-27]S11, [6074-39]S12
 Egiazarian, Karen O. SC761 Inst, 6064A Chr, [6064A-18]S4, [6064A-30]S6, [6065-11]S4
 Eich, Manfred [6070-05]S2
 Eick, Steve Review
 Einhorn, Richard A. [6075-18]S5, [6075-19]S5
 Ekin, Ahmet [6077-33]S6
 El Choubassi, Maha M. [6072-16]S12
 El Seed, Ammar [6067-24]S8
 Elad, Michael [6077-03]S1
 Elbasi, Ersin [6072-73]S16
 Ellenrieder, Marc M. 6070 ProgComm
 Ellis, Stephen R. [6057-46]S3
 Ellisman, Mark H. [6068-26]S4
 El-Naqa, Issam M. [6065-28]S8
 El-Sharkawy, Mohamed [6077-72]S11
 England, Nick 6055B ProgComm
 Enomoto, Yoshiyuki [6068-11]S2
 Enser, Peter [6073-08]S3
 Erbacher, Robert F. 6060 S1 SessChr, 6060 S14 SessChr, 6060 S4 SessChr, 6060 Chr
 Ercil, Aytul [6077-05]S1
 Erol, Berna 6073 S9 SessChr, [6073-15]S5
 Escamilla-Hernández, Enrique [6063-16]S4
 Eschbach, Reiner 6058 Chr, 6058 S8 SessChr, 6058 S1 SessChr
 Eskicioglu, Ahmet M. [6059-08]S3, Review, 6072 ProgComm, 6072 S11 SessChr, [6072-73]S16, [6072-74]S16
 Ess, Eric [6060-02]S1, [6060-35]S15
F
 Fabricius, Maximilian H. [6068-35]S3, [6068-36]S3
 Fabrikant, Sara Review
 Fageth, Reiner [6058-13]S3
 Fairchild, Mark D. 6059 ProgComm
 Fan, Jian [6076-18]S4
 Fan, Kuo-Chin [6077-49]S9
 Fan, Zhigang Z. [6058-36]S8
 Fang, Hui [6073-31]S4
 Fang, Li-Te [6070-17]S4
 Farin, Dirk [6055A-19]S5, [6073-02]S1
 Farinella, Giovanni M. [6064A-34]S7
 Farnand, Susan 6059 ProgComm, 6059 S3 SessChr, [6059-19]S6
 Farrell, Joyce E. SC762 Inst, [6069-23]S7
 Farsaii, Babak [6065-30]S9
 Farsiu, Sina [6077-03]S1
 Fatemi, Omid [6074-13]S6
 Fauster, Ewald [6070-01]S1
 Favalora, Gregg E. 6055A ProgComm, 6055A S7 SessChr, [6055A-38]S10
 Fecker, Ulrich [6077-11]S2
 Fedi, Manoubi [6056-37]S6
 Fedorovskaya, Elena A. 6057 ProgComm
 Fei, Chuhong [6072-72]S16
 Feldman, Michael R. [6065-15]S5
 Felipussi, Sivovani C. [6064A-17]S3
 Feng, GuoCan [6064B-68]S6
 Feng, Guotong [6058-28]S6
 Feng, Wei [6065-36]S10
 Feng, Wu-chang [6071-19]S5
 Feng, Wu-chi 6071 ProgComm, [6071-19]S5
 Feng, Xiao-fan [6057-14]S5
 Feng, Xiaojun [6076-11]S3
 Fenimore, Charles P. [6057-17]S6
 Ferguson, James L. [6055A-57]S13
 Ferguson, Robin S. [6055B-70]S14
 Ferran, Nuria [6061-19]S7
 Ferre, Maria [6060-06]S2
 Ferriani, Stefano [6062-22]S6
 Fiadeiro, Paulo T. [6056-15]S3
 Fiddy, Michael A. [6065-15]S5
 Fielding, Julia R. [6060-04]S2
 Fiorio, Christophe [6066-14]S5
 Fischer, Dirk [6075-35]S9
 Fischer, Mani [6058-31]S7
 Fleming, Christopher E. [6072-28]S7
 Floeder, Steven P. 6070 ProgComm
 Fofi, David 6070 ProgComm, [6070-10]S3, [6070-24]S6, [6070-26]S7
 Foi, Alessandro [6064A-18]S4, [6064A-30]S6
 Foley, Colum [6073-07]S2
 Foley, John M. [6057-18]S6, [6059-32]S10
 Fontana, Raffaella [6062-22]S6
 Forbrigg, Peter [6074-28]S11
 Ford, Glenn [6076-03]S1
 Ford, Ralph M. 6070 ProgComm
 Forlines, Cliff [6073-18]S6
 Formaglio, Alessandro [6057-32]S8
 Foufou, Sebti [6070-09]S2
 Fox, Edward A. Review
 Franzini, Massimiliano [6057-32]S8
 Frattolillo, Franco [6072-67]S15
 French, Marcus J. [6068-03]S1
 Frenk, Carlos [6055A-05]S1
 Fridrich, Jessica 6072 S1 SessChr, 6072 ProgComm, [6072-01]S1, [6072-24]S6, [6072-34]S8, [6072-41]S9, [6072-68]S16
 Frieder, Ophir [6067-23]S7
 Friess, Martin [6056-20]S4
 Fritz, Markus [6055A-16]S4
 Froner, Barbara [6055A-05]S1
 Frossard, Pascal 6071 ProgComm, [6077-22]S4
 Fu, Chi-Wing [6060-20]S9
 Fu, Kun [6071-16]S5
 Fuchs, Georg [6074-28]S11
 Fuertler, Johannes [6063-14]S4
 Fujieda, Ichiro [6075-32]S8
 Fujii, Toshiaki [6055A-31]S8, [6056-36]S6
 Fujinami, Hiromitsu [6055A-48]S13
 Fujioka, Hiromu [6065-50]S12
 Fujishima, Osamu [6055B-67]S14
 Fujishiro, Issei [6060-17]S8

Participants

Fukuchi, Yoshikazu [6059-12]S4
 Fukuda, Hiroyuki [6062-16]S5, [6062-23]S7
 Fukuda, Masanori [6056-34]S6
 Fukushima, Kunihiko 6064B ProgComm
 Fukushima, Norishige [6056-36]S6
 Fukushima, Rieko [6055A-27]S7
 Fuller, Ray [6073-27]S8
 Funatsu, Ryohei [6068-09]S2, [6068-25]S4
 Fung, Kenneth S. M. [6056-01]S1, [6070-03]S1
 Funk, Wolfgang [6072-62]S14
 Funt, Brian V. [6057-04]S2, [6058-22]S5
 Furini, Luca [6076-22]S5
 Furnari, Mario M. [6061-23]S7
 Furon, Teddy 6072 ProgComm, [6072-52]S12
 Furst, Jacob D. [6065-48]S12
 Furumiya, Tetsuo [6068-14]S2
 Furuta, Richard Review, 6076 ProgComm
 Futch, Brad [6060-11]S5
G
 Gabbouj, Moncef [6074-05]S3, [6074-09]S5
 Gader, Paul D. 6064A ProgComm
 Gagliardi, Isabella [6061-11]S4, [6061-33]S10
 Gagnon, Langis [6064B-65]S6
 Galatsanos, Nikolas P. [6065-28]S8
 Gallegos-Funes, Francisco J. [6063-22]S5
 Gallo, Giovanni [6064A-34]S7
 Gamadia, Mark N. [6063-09]S3
 Gandhi, Bhavan [6074-08]S5
 Gao, Anyu [6077-53]S10
 Gao, Hewel [6064A-25]S5, [6065-35]S9, [6067-08]S3
 Gao, Sheng [6071-05]S1
 Gao, Wen [6077-29]S5, [6077-30]S5
 Garanzotis, Theodoros [6075-05]S2
 Gasparini, Francesca [6061-18]S6, [6069-12]S3
 Gaudreau, Jean E. [6055A-44]S12
 Gautam, Shantanu [6073-14]S4
 Gaykema, Frans 6059 ProgComm, 6059 S9 SessChr, [6059-20]S6
 Gebbensleben, Sandra [6074-30]S11
 Gee, Christelle [6070-23]S5
 Gegenfurtner, Karl [6057-49]S3
 Gelenbe, Erol 6064B ProgComm
 Gensel, Jérôme [6073-34]SA
 Gentsch, Lars [6074-20]S9
 Gerald-Yamasaki, Michael J. [6060-42]S15
 Germain, Mickael [6065-03]S2, [6065-47]S12
 Gesquiere, Gilles [6060-16]S7
 Gevers, Theo SC685 Inst, 6061 Chr, [6061-16]S6
 Ghaffari, Alireza [6064B-69]S6
 Ghanbari, Mohammed [6057-40]S13
 Ghasemi, Hamid Reza [6074-13]S6
 Gicquel, Jean-Charles [6057-20]S6
 Giesen, Joachim [6058-05]S1
 Giesen, Rob [6070-15]S4
 Gille, Jennifer 6057 ProgComm, [6057-30]S8, 6061 ProgComm
 Gilloire, Andre [6072-71]S16
 Gilson, Kevin J. [6055A-03]S1
 Gimson, Roger [6076-23]S5
 Girnyk, Vladimir I. [6075-26]S6, [6075-29]S7, [6075-41]S10
 Girod, Bernd [6077-17]S3, [6077-26]S5
 Girshtel, Eugene [6059-08]S3
 Glossner, John C. [6074-12]S6
 Godin, Guy [6055A-15]S4
 Goffredo, Michela [6064A-23]S5
 Goh, Chris [6055A-07]S2
 Goldmann, Lutz [6077-68]S11, [6077-70]S11
 Goljan, Miroslav [6072-01]S1, [6072-34]S8, [6072-41]S9
 Goma, Sergio R. [6069-13]S3, [6069-15]S4
 González, Alvaro J. [6057-11]S4
 Gonzalez Lozano, Alvaro J. [6058-39]S8
 Good, Walter F. [6055A-46]S13
 Goodman, Thomas J. [6064A-12]S2
 Gorria, Patrick [6070-10]S3, [6070-14]S4
 Gotchev, Atanas P. 6064A ProgComm
 Goto, Takayuki [6068-11]S2
 Gotsis, Mariantina [6055B-79]S16
 Gou, Hongmei [6072-35]S8, [6075-10]S3
 Gouet-Brunet, Valérie [6073-09]S3
 Gouton, Pierre [6070-06]S2
 Grandpierre, Thierry [6063-18]S4
 Grant, Josh [6060-11]S5
 Grau, Sergi [6060-06]S2
 Gray, Derek W. S. [6057-33]S8
 Greco, Marinella [6062-22]S6
 Grecos, Christos [6063-11]S3, [6074-03]S3, [6077-58]S11
 Green, Phil J. 6058 ProgComm, 6058 S2 SessChr, [6058-02]S1, [6059-07]S3
 Greenwade, L. E. 6060 ProgComm
 Grefenstette, Gregory [6061-13]S5
 Gresh, Donna Review
 Grinstein, Georges G. Review
 Griwodz, Carsten 6071 Chr
 Gröhn, Matti T. 6060 Chr, 6060 S2 SessChr, 6060 S5 SessChr, 6060 S12 SessChr
 Groller, Eduard Review
 Groom, Donald E. [6068-35]S3
 Grosky, William [6073-38]SA, [6077-75]S11
 Gross, Markus Review
 Gross, Martazsh [6057-17]S6
 Grossman, David [6067-23]S7
 Gu, Guohua [6059-38]S11
 Guan, Ling [6073-36]SA
 Guarnera, Giuseppe C. [6064A-34]S7
 Guenegues, Audrey [6077-11]S2
 Guida, Daniele [6059-40]S11
 Guidash, Robert M. [6069-03]S1
 Guillaume, Mireille [6064A-27]S6
 Guillemin, Jean-Philippe [6070-23]S5
 Guitart, Oriol [6072-58]S13
 Guitart, Oriol [6072-59]S13
 Guleryuz, Onur G. 6077 S1 SessChr, 6077 ProgComm
 Gumhold, Stefan Review
 Gunning, Deborah [6068-03]S1
 Guo, Junpeng P. [6065-15]S5
 Guo, Xun [6077-29]S5, [6077-30]S5
 Guo, Yi [6074-02]S2
 Gupta, Indranil [6071-13]S3
 Gupta, Maya R. 6065 ProgComm
 Gurrin, Cathal [6073-07]S2
 Gwun, Oubong [6066-25]S7
H
 Ha, Yeong-Ho [6058-19]S5, [6058-25]S6
 Haaland, David M. [6062-07]S2
 Haas, Bertrand [6075-10]S3
 Habib, Ahsan [6071-06]S2
 Haddad, Mohsen [6072-71]S16
 Hagura, Hiroyuki [6057-12]S4
 Hahn, Daniel V. [6056-14]S3
 Haj Said, Eyad [6064A-26]S5
 Hakkani-Tür, Dilek [6072-10]S2
 Häkkinen, Jukka P. [6055A-10]S3, [6059-02]S1
 Halvorsen, Pål 6071 ProgComm
 Hamann, Bernd [6060-41]S15
 Hampapur, Arun 6073 ProgComm
 Hampden-Smith, Mark J. [6075-18]S5, [6075-19]S5
 Hamppp, Norbert A. [6075-21]S5
 Hamzaoui, Raouf [6071-04]S1
 Han, Hui-Ya G. [6057-01]S2
 Han, Jungong [6073-02]S1
 Handley, John C. 6064A ProgComm
 Hands, David [6057-19]S6, [6057-40]S13
 Haneishi, Hideaki [6062-16]S5
 Hanjalic, Alan 6073 S4 SessChr, 6073 Chr, [6073-40]S
 Hanna, Philip M. [6056-07]S2
 Hanrahan, Patrick Review
 Hanson, Andrew J. [6060-20]S9
 Hao, Ming C. 6060 S9 SessChr, 6060 S6 SessChr, 6060 CoChr
 Hardeberg, Jon Y. 6062 ProgComm, [6070-06]S2
 Hardman, Ned [6075-18]S5
 Hare, Jonathon S. [6073-08]S3
 Härkönen, Lari [6062-19]S5
 Harman, William M. [6068-16]S3
 Haroutunian, Mariam E. [6072-39]S9
 Harper, Mary P. [6065-02]S2
 Harrington, Steven J. 6076 S1 SessChr, 6076 ProgComm, [6076-08]S2
 Hartley, Richard J. [6073-11]S3
 Hascoët, Mountaz [6060-26]S12
 Hasegawa, Takuya [6061-25]S8
 Hashimoto, Nobuyuki [6061-34]S10
 Hashimoto, Sayuri [6061-34]S10
 Hassaine, Djamel [6055A-05]S1
 Hassan, Friras [6064A-31]S6
 Haubrich, Scott [6075-18]S5, [6075-19]S5
 Hauer, Enrico [6072-45]S11
 Haupt, Jarvis [6065-07]S3
 Hauptmann, Alexander G. [6061-08]S3, 6073 ProgComm, [6073-12]S4, [6073-37]SA
 Hausner, Alejo [6058-38]S8
 Haussler, David H. 6064B ProgComm
 Hauta-Kasari, Markku 6062 ProgComm, 6062 S4 SessChr, [6062-19]S5, [6062-21]S6, [6062-23]S7, [6062-27]S8
 Haverkamp, Donna S. [6057-17]S6
 Havig, Paul R. [6055A-12]S3
 Havre, Susan L. [6060-22]S10
 Havrilyuk, Alexandr I. [6068-32]S
 Hayhoe, Mary M. [6057-45]S1
 He, Shan [6072-64]S15
 He, Zhihai 6074 ProgComm, 6074 S9 SessChr, [6077-27]S5, [6077-28]S5, [6077-60]S11, [6077-61]S11
 Healey, Chris G. Review
 Hède, Patrick [6061-13]S5
 Hege, Hans-Christian Review
 Heidrich, Wolfgang SC772 Inst
 Heise, Bettina [6070-22]S5
 Heitzenrater, Chad D. [6072-04]S1
 Helling, Stephan [6062-25]S8
 Hellwagner, Hermann [6071-12]S3
 Helly, John [6055A-05]S1
 Hel-Or, Hagit Z. 6061 ProgComm
 Helt, François [6059-28]S9
 Hemami, Sheila S. [6057-07]S4, 6077 ProgComm, [6077-24]S4
 Hendry, Hendry [6072-60]S14
 Hennemeyer-Schwenkner, Michael [6075-35]S9
 Hernández, Begoña [6062-02]S1
 Hernandez, Luis [6067-12]S4
 Hernandez-Andres, Javier 6062 S2 SessChr, [6062-09]S3
 Herrera-Joancomarti, Jordi [6072-55]S13
 Herrigel, Alexander [6075-33]S8
 Herron, Stephen [6058-33]S8
 Hersch, Roger David 6058 ProgComm, 6061 ProgComm, [6075-28]S7
 Hertel, Dirk W. 6059 ProgComm, 6059 S8 SessChr, [6059-25]S8
 Herzog, Patrick G. 6058 ProgComm
 Hesser, Jürgen [6065-12]S4
 Hewitt, William T. [6073-11]S3
 Hill, Bernhard 6062 ProgComm
 Hill, Douglas L. [6056-25]S5
 Hillebrand, Mario [6075-35]S9
 Hilley, David [6071-07]S2
 Hintz, Wayne [6069-03]S1
 Hirano, Yasushi [6074-31]S11
 Hirayama, Teruo [6068-11]S2
 Hirayama, Yuzo [6055A-27]S7
 Hix, Deborah Review
 Ho, Hsin-Han [6059-32]S10
 Hochbaum, Aharon [6055A-57]S13
 Hochheiser, Harry Review
 Hooctor, Ralph T. [6065-17]S5
 Hoefler, Martin [6060-23]S10
 Hoefflinger, Bernd SC772 Inst
 Hoenkamp, Eduard [6073-35]SA
 Hofrichter, Klaus [6071-14]S4
 Hogan, Mark T. [6072-30]S7
 Höllner, Tobias [6055A-45]S12
 Holliman, Nicolas S. 6055A ProgComm, 6055A S10 SessChr, [6055A-05]S1
 Holmes, Brian [6075-29]S7
 Holotyak, Taras S. [6072-01]S1
 Homma, Mitsuru [6056-04]S1
 Honda, Toshio [6055A-30]S8
 Horesh, Nadav [6055A-09]S2
 Horii, Hideyuki [6060-17]S8
 Horita, Yuukou 6076 ProgComm
 Hörning, Henrik [6074-39]S12
 Hörning, Reidar [6074-39]S12
 Hornsey, Richard I. [6068-06]S2
 Horttanainen, Pekka [6062-19]S5
 Hoshino, Kazunori [6055A-53]S13
 Hossfeld, Michael [6070-05]S2

Participants

Houissa, Hichem [6073-16]S5
Hsieh, Jiang [6065-33]S9
Hsing, T. Russell 6077
ProgComm
Hsu, Wen-Jun [6064A-40]S7
Hu, Chia-Lun J.
[6064B-56]S10,
[6064B-61]S10
Hu, Hao [6077-37]S7
Hu, Jianying 6067 ProgComm
Hu, Wen-Fong [6070-28]S7
Hu, Zhencheng [6066-02]S1
Huang, Feng [6071-08]S2
Huang, Hau M. [6058-43]S9
Huang, Jie [6071-19]S5
Huang, Jiwu [6072-15]S3
Huang, Mai [6066-27]S7
Huang, Qingming [6073-20]S6
Huang, Thomas S.
MeetingVIP, [6073-37]SA
Huang, Wan-Jian [6075-16]S4
Huang, Xiaodong [6077-35]S6
Huang, Yan [6065-06]S2
Huang, Yong [6057-13]S5
Hubel, Paul M. [6069-22]S7
Huber, Matthew [6060-02]S1
Huet, Benoît [6073-22]S7
Huhtelin, Petri [6062-19]S5
Hull, Jonathan J. [6073-15]S5
Hultgren, Eror O. [6059-25]S8,
[6059-26]S8
Hung, Chi-Hsuan [6069-11]S3
Hung, Yeung-Sam
[6066-09]S3, [6066-19]S6,
[6066-20]S6
Hunn, John D. [6070-18]S4
Hunt, David [6075-31]S8
Hur, Namho [6055A-11]S3,
[6055A-49]S13,
[6055A-50]S13,
[6055A-58]S13,
[6055A-59]S13, [6056-35]S6,
[6061-35]S10
Hurley, Neil J. [6072-30]S7,
[6072-31]S7, [6073-04]S2
Hurst, Matthew F. 6067
ProgComm
Husák, Michal [6055A-01]S1
Husak, Walter J.
[6055A-18]S4
Hussaini, M. Y. [6060-11]S5
Huynh-Thu, Quan
[6057-40]S13
Hwang, Youngha [6065-16]S5
Hytti, Heli H. [6059-10]S4
I
Iancu, Daniel [6074-12]S6
Ichihara, Yasuyo G.
[6058-12]S3, 6061
ProgComm
Ichikawa, Hirokazu
[6062-13]S4
Ideses, Ianir A. [6056-11]S3
Idier, Jérôme [6065-18]S5
Idrissi, Khalid [6072-50]S12
Igartá, Michael [6074-08]S5
Ignatenko, Tanya [6072-65]S4
Ikeda, Hisashi 6067
ProgComm
Ilgner, Justus F. R.
[6055A-06]S2
Ilie, Adrian [6055B-77]S16
Imai, Francisco H. 6062 S1
SessChr, 6062 Chr
Imiya, Atsushi 6066
ProgComm
Ingra, Elisa [6061-29]S9
Inoue, Tetsuri [6055A-47]S13
Interrante, Victoria
[6057-24]S7
Inuiya, Masafumi [6068-12]S2
Irvine, John M. [6057-17]S6
Irwin, George [6068-27]S4
Israel, Steven A. [6057-17]S6
Ito, Manabu [6073-10]S3
Itti, Laurent 6057 ProgComm,
[6057-50]S3
Ivanovski, Zoran A.
[6077-07]S1
Iwama, Ryo [6062-16]S5
Iwane, Kousuke [6055A-30]S8
Iwasaki, Hiroaki [6062-03]S1
Iwasaki, Tsuneto
[6055A-14]S3
Iwase, Hiroki [6056-31]S6,
[6056-33]S6
Izadi, Mohammad H.
[6068-04]S1
J
Jaaskelainen, Timo
[6062-21]S6
Jackson, J. C. [6068-15]S3
Jacobs, Charles 6076
ProgComm
Jae Lin, Lee [6055A-14]S3
Jaeger, Stefan R.
[6067-09]S4, [6067-11]S4
Jaimes, Alejandro
[6061-03]S2, 6073
ProgComm
Jakob, Gerhard [6070-21]S5
Jamet, Damien [6066-14]S5
Janeczek, Martin [6065-29]S9
Janesick, James R. SC504
Inst
Jang, Euee S. [6061-35]S10
Jang, In-Su [6058-25]S6
Jang, Woonyoung
[6059-13]S5
Janssen, Johan [6077-39]S7
Janvier, Bruno [6073-33]SA
Jarrah, Kambiz [6073-36]SA
Jaspers, Egbert G. T.
[6073-26]S8
Jenkin, Robin B. 6059 S7
SessChr, 6059 ProgComm
Jenkins, Adrian [6055A-05]S1
Jeong, Dong-Seok
[6077-16]S2, [6077-65]S11
Jeong, Ho-Seop [6059-30]S9,
[6068-28]S4
Jeong, Youngho [6074-37]S12
Jiang, Deming [6064B-63]S11
Jiang, Jianmin [6073-31]SA
Jiang, Lian [6060-40]S15
Jiang, Maodong
[6064A-02]S1
Jin, Liang [6068-26]S4
Jin, Sung Ho [6061-32]S10
Jin, Xin [6077-64]S11,
[6077-82]S11
Jin, Yongsu [6059-30]S9,
[6068-28]S4
Jiten, Joakim [6073-22]S7
Johnson, Paul [6058-11]S3
Jones, Howland D. T.
[6062-07]S2
Jonza, James M. 6075 S4
SessChr, 6075 ProgComm,
[6075-15]S4
Jorke, Helmut [6055A-16]S4
Joshi, Ashutosh [6067-06]S3
Joshi, Parag [6076-06]S1,
[6076-25]S6
Josse, Julie [6072-52]S12
Joyeux, Laurent [6073-27]S8
Jubran, Mohammad K.
[6077-13]S2
Jung, Cory G. [6059-33]S10,
[6068-04]S1
Jung, Yong Ju [6077-79]S11
K
Kacker, Dhiraj 6076
ProgComm, 6076 S6
SessChr
Kagawa, Keiichiro
[6068-01]S1, [6068-02]S1,
[6068-14]S2
Kagawa, Shuichi [6058-17]S4
Kajita, Shoji [6074-31]S11
Kakeya, Hideki [6055A-33]S8,
[6055B-75]S16
Kalker, Ton 6072 ProgComm,
[6072-65]S4
Kameda, M. [6057-06]S3
Kanazawa, Hiroshi
[6062-16]S5
Kaneko, Hideyuki [6058-17]S4
Kang, Byong Min [6058-30]S7
Kang, Byoung-Ho
[6058-06]S1
Kang, Byungho [6058-24]S6
Kang, Ho-Hyun [6066-29]S8
Kang, Hoonjong
[6055A-58]S13,
[6055A-59]S13
Kang, Moon Gi [6064A-35]S7,
[6064A-37]S7
Kang, Xiangui [6072-15]S3
Kankanhalli, Mohan S. 6073
ProgComm
Kanungo, Tapas 6067
ProgComm
Kappe, Frank [6075-35]S9
Karam, Lina J. 6077
ProgComm, [6077-07]S1
Karaman, Mustafa
[6077-68]S11
Karayiannis, Nicolaos B.
6064B ProgComm
Karcher, Armin [6068-35]S3
Karim, Karim S. [6068-04]S1
Karnick, Pushpak A.
[6056-21]S4, [6056-22]S4
Kasahara, Masao [6072-20]S4
Kasuga, Hideo [6061-25]S8
Katkovnik, Vladimir SC761
Inst, [6064A-18]S4,
[6064A-30]S6, [6065-11]S4
Kato, Katsushi [6059-12]S4
Katsaggelos, Aggelos K.
[6077-25]S1
Katsumoto, Michiaki
[6071-10]S3
Kaufmann, Benoît
[6063-17]S4
Kaup, André [6077-11]S2
Kavusi, Sam [6069-23]S7
Kawada, Ryoichi [6059-29]S9
Kawahito, Shoji [6056-04]S1,
[6068-13]S2
Kawai, Takashi [6055A-06]S2,
[6055A-14]S3,
[6055A-47]S13
Kawamoto, Tetsuya
[6055A-77]S13
Keahey, T. Alan Review
Kehtarnavaz, Nasser 6063
Chr, 6063 S1 SessChr,
[6063-09]S3
Keim, Daniel C. Review
Kelly, Kevin F. [6065-09]S3
Kelso, David M. [6064A-38]S7
Kender, John R. 6073
ProgComm
Ker, Andrew D. [6072-03]S1,
[6072-06]S1
Kercher, Andrew K.
[6070-18]S4
Kerofsky, Louis J. [6057-16]S5
Kershaw, Christopher J.
[6066-30]S8
Kevenaar, Tom [6072-19]S4
Keysers, Daniel [6058-03]S1
Khan, Iffat [6065-40]S11
Khan, Mohammad S.
[6067-10]S4
Kharrazi, Mehdi [6072-05]S1
Khelashvili, Gocha
[6065-32]S9
Khokhar, Ashfaq A.
[6072-70]S16
Kieffer, Michel [6077-15]S2
Kikuchi, Hisakazu
[6069-07]S2
Kim, Changick [6074-35]S12,
[6077-63]S11
Kim, Changsung [6077-10]S2
Kim, Chang-Yeong
[6058-06]S1, [6058-14]S4,
[6058-16]S4, [6058-20]S5,
[6069-14]S4, [6058-15]S4
Kim, Cheon Seog
[6059-37]S11
Kim, Choon-Woo 6058
ProgComm, 6058 S4
SessChr, [6058-30]S7
Kim, Daehee [6055A-58]S13
Kim, Daiyong [6061-35]S10
Kim, Dong-chul
[6055B-68]S14
Kim, Duck Yeon [6074-06]S3
Kim, Eun-Soo [6055A-61]S13,
[6066-29]S8
Kim, Geon [6074-37]S12
Kim, Hye Jin [6077-87]S11
Kim, Hyung Cook
[6072-58]S13, [6072-59]S13
Kim, Inho [6065-46]S12
Kim, Inji [6057-34]S13
Kim, Jae-Gon [6061-32]S10,
[6074-06]S3
Kim, Jangheon [6055A-23]S6
Kim, Jee Hong [6069-17]S4,
[6070-30]S7
Kim, Jong Man [6058-19]S5
Kim, Joohwan [6055A-37]S9,
[6055A-54]S13
Kim, Kang-Yeon
[6055A-50]S13
Kim, KwanLae [6074-24]S10
Kim, Munchurl [6072-60]S14,
[6073-23]S7, [6074-24]S10
Kim, Munjo [6074-24]S10
Kim, Nam [6074-40]S12
Kim, Namjin [6063-09]S3
Kim, Sang Ho [6058-29]S7,
[6058-30]S7
Kim, Seung-Cheol
[6055A-61]S13
Kim, Seung-Man
[6055A-50]S13
Kim, Sun Review
Kim, Sung-Kwa [6068-28]S4
Kim, Sung-Su [6058-16]S4
Kim, Taehyun [6077-46]S9
Kim, Whanwoo [6074-37]S12
Kim, Woosuk [6074-36]S12
Kim, Young Suk
[6059-37]S11, [6077-79]S11
Kim, Yunhee [6072-23]S6
Kim, Yunhee [6055A-37]S9,
[6055A-54]S13
Kim, Yuntae [6058-26]S6
Kimpe, Tom R. [6057-15]S5
Kimura, Nobutaka
[6055A-35]S9
Kimura, Tetsuya
[6055B-75]S16
King, Brian [6072-43]S10
King, James C. [6076-07]S2
Kinsler, Jason M.
[6064B-59]S10, [6065-27]S8
Kiranyaz, Serkan [6074-09]S5
Kirchner, Claus [6071-09]S2
Kishi, Shinsuke
[6055A-47]S13
Kishimoto, Junko [6062-16]S5
Kitagura, S. [6057-02]S2
Kitazawa, Hitoshi [6063-23]S5
Kiyancilar, Nadir [6071-02]S1
Klaassens, Wilco [6068-34]S3
Klaus, Enrico [6074-27]S11
Klein, Stanley A. 6057
ProgComm, [6057-53]S10
Kleinfelder, Stuart
[6068-26]S4
Klement, Erich P. [6070-22]S5
Knapik, Timothy [6072-04]S1
Knight, Claire Review
Knight, Malcolm R. M. 6075
ProgComm, 6075 S8
SessChr
Knoche, Hendrik O.
[6074-29]S11
Ko, Kyung-Woo [6058-25]S6
Kobourov, Stephen G. Review
Kockro, Ralf [6055A-07]S2
Kodas, Toivo [6075-19]S5
Koenderink, Jan J. 6057
ProgComm
Koetter, Ralf [6072-53]S12
Koga, Tatsuzo [6061-34]S10
Koga, Toshio [6057-36]S13
Koh, Chin Chye [6057-18]S6
Kohonen, Oili [6062-27]S8
Koike, Atsushi [6059-29]S9,
[6077-43]S8
Koike, Takafumi [6055A-35]S9
Koivusaari, Jari J.
[6074-05]S3
Kok, Thijs [6057-25]S7,
[6073-35]SA
Kokaram, Anil C. 6073 S2
SessChr, 6073 ProgComm,
[6073-03]S1, [6073-27]S8
Koll, Christian [6070-08]S2
Koller, Norbert [6070-01]S1
Komatsu, Naohisa
[6072-20]S4
Komatsu, Takashi
[6065-37]S10, [6069-05]S1,
[6069-08]S2, [6077-56]S11
Kondi, Lisimachos P.
[6077-13]S2, [6077-77]S11,
[6077-81]S11
Konrad, Janusz 6055A
ProgComm, 6055A S5
SessChr, 6077 ProgComm

Participants

- Koplowitz, Jack 6066 ProgComm
 Koren, Israel [6059-33]S10
 Koren, Norman L. [6069-21]S6
 Koren, Zahava [6059-33]S10
 Kornbrekke, Ralph [6075-18]S5
 Korva, Jari [6074-26]S10
 Kosinov, Serhiy [6073-39]SA
 Kosko, Bart 6064B ProgComm
 Kostyukevich, Sergey O. [6075-41]S10, [6075-40]S10
 Kot, Alex C. 6077 ProgComm
 Koutaki, Go [6066-02]S1
 Koval, Oleksiy J. [6072-33]S7, [6072-38]S9, [6072-39]S9, [6072-49]S12, [6072-51]S12, [6073-32]SA
 Kozintsev, Igor V. [6061-01]S1
 Kozloski, James [6057-26]S7, [6064B-60]S10
 Kraemer, Eileen Review
 Kraetzer, Christian [6072-56]S13
 Kravchenko, Victor F. [6063-16]S4
 Krawczyk, Grzegorz [6057-05]S2
 Kremser, Gert [6072-66]S15
 Kress, William C. [6059-20]S6
 Kretschmar, Friedrich [6075-38]SB
 Kreylos, Oliver [6060-41]S15
 Krim, A. Hamid [6065-05]S2
 Kriss, Michael A. 6058 S3 SessChr, 6058 ProgComm, 6069 ProgComm, 6069 S2 SessChr
 Kryuchyn, Andriy A. [6075-40]S10
 Kuan, Ming-Tsung [6075-16]S4
 Kuboshima, Yasuhito [6055A-30]S8
 Kudo, Yoshiaki [6058-23]S5
 Kumamoto, Keishi [6058-18]S5
 Kumar, Pancham [6058-10]S3
 Kumar, Sanjeev [6066-24]S7
 Kundur, Deepa [6072-72]S16
 Kung, Sun-Yuan 6064B ProgComm
 Kuno, Yasuhiro [6055A-47]S13
 Kuo, C. C. J. [6077-10]S2, 6077 ProgComm
 Kuo, Cheng-Hang [6070-17]S4
 Kuo, Chunhui [6059-16]S5
 Kuo, Pei-Jeng [6073-10]S3
 Kuppens, Harco C. [6063-06]S2, [6066-17]S5
 Kurceren, Ragip [6077-76]S11
 Kurita, Masashi [6075-32]S8
 Kurita, Takaaki [6059-34]S10
 Kutter, Martin 6072 ProgComm
 Kwak, Won-Gee [6077-59]S11
 Kwak, Youngshin [6058-20]S5
 Kwon, Heesung 6064B S8 SessChr, 6064B S7 SessChr, [6064B-50]S7
 Kwon, Hyoung Jin [6056-35]S6
 Kwong, Raymond [6072-72]S16
 Kyan, Matthew J. [6073-36]SA
L
 La Haye, Michelle L. [6068-04]S1
 Laamanen, Hannu T. [6062-19]S5, [6062-21]S6
 Labat, Christian [6065-18]S5
 Lacelle, Martine P. [6075-05]S2
 Legendijk, Reginald L. 6072 ProgComm, [6072-11]S3, [6072-12]S3, [6072-21]S5, 6077 ProgComm
 Lahti, Janne [6074-26]S10
 Lai, PoLin [6077-09]S2
 Laidlaw, David Review
 Laird, Justin L. [6057-03]S2
 Laligant, Olivier [6070-14]S4, [6070-31]S7
 Lalonde, Marc [6064B-65]S6
 Lam, Edmund Y. [6056-01]S1, [6069-16]S4, [6069-19]S5, 6070 ProgComm, [6070-03]S1, [6070-04]S1, [6070-16]S4, [6070-25]S6
 LaMar, Eric C. [6060-05]S2
 Lancaster, Ian M. 6075 ProgComm, 6075 S7 SessChr, [6075-23]S6
 Landis, Emily K. [6056-21]S4
 Landis, Marvin [6055B-66]S13
 Lang, Andreas [6072-54]S13, [6072-56]S13
 Laplante, Phillip A. 6063 Chr
 Lashansky, Steven [6068-30]S5
 Lastra, Anselmo A. Review
 Latecki, Longin Jan SC754 Inst, [6065-42]S11, 6066 S1 SessChr, 6066 S2 SessChr, 6066 Chr
 Lau, Daniel L. [6057-11]S4, [6058-39]S8, [6062-24]S7
 Lau, Johnny K. H. [6071-17]S5
 Laudanski, Jonathan [6068-03]S1
 Lawrence, Kurt C. [6070-07]S2
 Le, Han Q. [6062-12]S4
 Le, Hoang M. [6064A-39]S7
 Le, Triet M. [6065-19]S6
 Le Callet, Patrick [6057-08]S4
 Le Guelvouit, Gaetan [6072-29]S7
 Le Guyader, Alain [6072-71]S16
 Le Squin, Sandrine [6072-52]S12
 Leader, Joseph K. [6055A-46]S13
 Leahy, Richard M. MeetingVIP
 Lebart, Katia 6070 ProgComm
 Leblanc, Philippe C. [6068-26]S4
 Lebowsky, Fritz [6057-13]S5
 Lee, Bong-Sun [6065-38]S10
 Lee, Bumshik [6073-23]S7
 Lee, ByoungHo [6055A-37]S9, [6055A-54]S13
 Lee, Chia-Yun [6058-21]S5
 Lee, Chulhee [6059-06]S2, [6065-46]S12
 Lee, Clive [6073-03]S1
 Lee, Dai Boong [6077-47]S9
 Lee, Elisa T. [6066-04]S1, [6066-15]S5, [6066-18]S5
 Lee, Eunjae [6059-06]S2
 Lee, Gwangsoon [6074-40]S12
 Lee, Ho-Young [6058-16]S4, [6069-14]S4
 Lee, Hyowon [6073-07]S2
 Lee, Ivan [6073-36]SA
 Lee, Jack Y. B. [6071-17]S5
 Lee, Jaeho [6055A-62]S13
 Lee, Jae-Hyun [6077-59]S11
 Lee, Jinhwan [6074-40]S12
 Lee, Jong-Gil [6055A-61]S13
 Lee, JungHo [6077-16]S2, [6077-65]S11
 Lee, Junghoon [6065-10]S4
 Lee, Jun-Yong [6055A-62]S13
 Lee, KiUn [6068-28]S4
 Lee, Kun 6066 S3 SessChr, [6066-25]S7
 Lee, Kwan-Heng [6055A-50]S13
 Lee, Kyung-kook [6055A-55]S4
 Lee, Meng-En [6064A-40]S7
 Lee, Mong-Shu [6064A-33]S7
 Lee, Myong-Young [6058-19]S5
 Lee, Robert [6075-11]S3
 Lee, Samuel C. 6066 S7 SessChr, [6066-04]S1, [6066-15]S5, [6066-18]S5
 Lee, Sang Wook [6077-62]S11
 Lee, Sanghyuck [6059-30]S9
 Lee, Sangwook [6059-06]S2
 Lee, Sang-Yong 6063 ProgComm
 Lee, Seok Cheon [6068-28]S4
 Lee, Seong-Deok [6057-34]S13, [6058-15]S4, [6058-20]S5, [6069-14]S4
 Lee, Sooin [6074-37]S12, [6074-40]S12
 Lee, Soo-In [6055A-49]S13, [6056-35]S6, [6061-35]S10
 Lee, Soo-Jin [6065-44]S12
 Lee, Sunyong [6061-35]S10
 Lee, Woongho [6077-16]S2, [6077-65]S11
 Lee, Yonghoon [6074-40]S12
 Lee, Yun-Gu [6055A-21]S5, [6077-87]S11
 Leech, Patrick W. [6075-11]S3
 Leeming, Kristy J. [6059-07]S3
 Leigh, Jason Review
 Leisti, Tuomas [6059-02]S1
 Lemke, Christiane [6074-19]S9
 Lemma, Awake N. [6072-42]S10
 Lennon, Daire [6073-27]S8
 Lenz, Reiner 6061 ProgComm, 6062 ProgComm
 Lepage, Gérald [6068-08]S2
 Lerner, Jürgen [6060-23]S10
 Leung, Clement H. C. 6061 ProgComm
 Leung, Wing H. [6070-03]S1
 Levine, Zachary H. [6065-31]S9
 Lew, Michael S. 6073 ProgComm
 Lewis, D. [6067-23]S7
 Lewis, Paul H. [6073-08]S3
 Li, Baochun 6071 ProgComm, [6071-11]S3
 Li, Baoxin [6077-32]S6
 Li, Chun Wen [6077-48]S9
 Li, Chung-Sheng 6073 ProgComm
 Li, Dalong [6065-20]S7
 Li, Guo [6058-09]S2
 Li, Houqiang [6074-02]S2
 Li, Jingqiang 6069 S7 SessChr, 6069 ProgComm
 Li, Jonathan Q. [6070-02]S1
 Li, Kang [6071-20]S5
 Li, Liya [6060-03]S1
 Li, Peng 6056 S6 SessChr, 6056 S3 SessChr, 6056 Chr
 Li, Qin [6064A-16]S3
 Li, Shengdong [6068-26]S4
 Li, Shidong [6056-41]S6
 Li, Shipeng 6077 ProgComm, [6077-29]S5, [6077-30]S5
 Li, Shiyong [6062-08]S3
 Li, Shuanglei [6065-35]S9
 Li, Xin [6056-38]S6
 Li, Xin 6074 ProgComm, [6077-01]S1
 Li, Xiongwen [6077-12]S2
 Li, Xu [6066-28]S8
 Li, Zhen [6077-18]S3, [6077-20]S3
 Liang, Dequn [6057-41]S13
 Liang, Jin [6071-21]S6
 Liang, Yi 6077 ProgComm
 Liao, Jiarui [6056-02]S1
 Lichtenstein, Terri L. [6075-13]S4
 Lienard, Bruno [6063-05]S2
 Lienhart, Rainer W. 6073 ProgComm, 6073 SB SessChr, 6073 S8 SessChr, [6073-30]S9
 Lieu, Linh H. [6065-19]S6
 Liinasuo, Marja [6055A-10]S3
 Likforman, Laurence [6067-21]S6
 Lim, Jeongyeon [6074-24]S10
 Lim, Kenny H. S. [6057-07]S4
 Lim, SukHwan [6069-24]S7
 Lima, Manuel S. [6060-32]S15
 Lin, Hai [6058-40]S9
 Lin, Michael [6056-16]S3
 Lin, San Yuan [6057-01]S2
 Lin, Siming H. [6070-15]S4
 Lin, Tsung-Nan [6064A-40]S7
 Lin, Wei-Hao [6073-12]S4
 Lin, Xia Review
 Lin, Xiaofan 6067 Chr, [6067-14]S5, [6076-06]S1, [6076-21]S5
 Linsen, Lars Review, [6060-31]S14
 Lippmann, Richard P. 6064B ProgComm
 Liu, Changsong [6067-13]S4, [6067-16]S5
 Liu, Dezhi [6056-41]S6
 Liu, Hailong [6067-16]S5
 Liu, Limin [6077-18]S3, [6077-20]S3, [6077-45]S9
 Liu, Peng [6074-14]S6, [6074-15]S6, [6074-42]S12
 Liu, Wei [6074-34]S12
 Liu, Wen yu [6077-82]S11
 Liu, Ying [6077-42]S8
 Liu, Yuan [6057-26]S7
 Liu, Zhen [6066-27]S7
 Liu, Zheng-Guang [6058-41]S9
 Liebaria, Antoine [6064A-27]S6
 Lo, Ephraim [6072-04]S1
 Loce, Robert P. [6058-35]S8
 Lodha, Suresh K. Review, [6066-23]S6
 Lohweg, Volker [6075-02]S1
 Lomheim, Terrence S. 6068 ProgComm
 Long, Jonathan L. [6061-22]S7
 Long, L. Rodney [6061-22]S7
 Loomis, Andrew H. [6068-18]S3
 Loose, Harald [6074-19]S9
 Lopera, Olga L. [6062-04]S2
 Lopez-Alvarez, Miguel A. [6062-09]S3
 Lopresti, Daniel P. 6067 ProgComm, [6067-06]S3
 Lorimor, Lynn E. [6075-15]S4
 Love, Shaun T. 6058 ProgComm, [6059-15]S5
 L'Ozano, Wilson [6076-26]S6
 Lu, Chun-Shien [6077-49]S9
 Lu, Dongming [6059-38]S11
 Lu, Yan [6077-29]S5, [6077-30]S5
 Lu, Yung-Hsiang [6065-21]S7, [6073-14]S4
 Luca, Damiani [6064A-15]S3
 Lugmayr, Artur R. [6074-21]S9
 Lukas, Jan [6072-34]S8
 Lukin, Vladimir V. 6064A ProgComm
 Lumley, John 6076 ProgComm, 6076 S2 SessChr, [6076-23]S5
 Luo, Gaoyong [6063-03]S1, [6074-04]S3
 Lustenberger, Felix [6056-03]S1
 Lyon, Richard F. [6069-01]S1
M
 Ma, Bo [6056-23]S4
 Ma, Kwan-Liu Review
 Ma, Wei-Ying 6073 ProgComm
 Ma, Zhengming [6074-34]S12
 MacDonald, Lindsay W. [6057-02]S2, [6058-10]S3, [6059-04]S2, [6069-18]S5
 Mack, Ian W. [6055B-70]S14
 MacNaughton, Boyd [6055A-44]S12
 Macq, Benoît B. 6072 S6 SessChr, 6072 S13 SessChr, 6072 ProgComm, [6072-57]S13
 Madjid, Allili [6066-21]S6
 Maeda, Yasunari [6056-04]S1
 Maerz, Norbert Review
 Magrassi, Grazia [6056-26]S5
 Mai, Fei [6066-09]S3
 Mairesse, Fabrice [6070-20]S5
 Maiti, Srijib [6074-11]S6
 Maitz, Glenn S. [6055A-46]S13
 Maki, Stephen P. [6075-15]S4

Participants

Makino, Takao [6062-13]S4
 Makovoz, David [6065-40]S11
 Malik, Aamir [6056-08]S2
 Malik, Hafiz M. [6072-70]S16
 Mallows, Colin L. [6067-17]S5
 Malzbender, Thomas [6060-10]S5
 Mamidi, Suman [6074-12]S6
 Manabe, Yoshitsugu 6062
 ProgComm, [6062-08]S3
 Mane, Ketan K. 6060 S10
 SessChr, 6060 S11 SessChr, [6060-36]S15
 Mangin, Patrice J. [6059-01]S1
 Manjunath, Bangalore S. 6072
 ProgComm, 6077
 ProgComm
 Mantiuk, Rafal [6057-23]S6
 Mantravadi, Anand V. S. [6077-81]S11
 Marchand-Maillet, Stéphane [6073-33]SA, [6073-39]SA
 Marchese, Francis T. Review
 Marcinak, Michael P. [6072-48]S11
 Marcu, Gabriel G. SympChair, SC516 Inst, SC075 Inst, 6058 Chr, 6058 S5 SessChr
 Mariappan, Ashok [6074-08]S5
 Marin, Ambroise [6070-06]S2
 Markantes, Tom [6075-17]S5
 Marquet, Bruno [6065-32]S9
 Marsh, Ian 6071 ProgComm
 Marsh, John A. [6072-04]S1
 Marshall, Stephen 6064A
 ProgComm
 Martin, Alexandre [6060-16]S7
 Martin, Hervé [6073-34]SA
 Martin, Russel A. 6069 S1
 SessChr, 6069 Chr
 Martinetz, Thomas [6057-49]S3
 Martinkauppi, J. Birgitta [6062-19]S5
 Martinu, Ludvik [6075-42]S10
 Marvel, Lisa M. [6072-07]S1
 Mascarilla, Laurent [6077-85]S11
 Masci, Frank J. [6065-40]S11
 Mase, Kenji [6074-31]S11
 Mase, Mitsuhiro [6068-13]S2
 Massicotte, Philippe [6055A-15]S4
 Mastroianni, Maria Grazia [6062-22]S6
 Matabosch, Carles [6070-24]S6
 Mateos, Javier [6077-25]S1
 Materazzi, Marzia [6062-22]S6
 Mather, Paul M. [6064B-69]S6
 Matherson, Kevin J. SC753
 Inst
 Mathieson, Keith [6068-03]S1
 Mathur, Abhishek [6064A-38]S7
 Matsuda, Isamu [6055A-33]S8
 Matsumoto, Hiroyuki 6075
 ProgComm
 Matsumoto, Kazumasa [6059-12]S4
 Matsumoto, Kiyoshi [6055A-53]S13
 Matsumura, Atsushi [6077-83]S11
 Matsuo, Masamichi [6068-01]S1
 Matusik, Wojciech [6055A-24]S6
 Matveyev, Sergey V. Review
 Mauro, Animali [6064A-15]S3
 Mauthe, Andreas U. 6071
 ProgComm, [6071-23]S6
 Mayer, Konrad J. [6063-14]S4
 Mayer-Patel, Ketan D. 6071
 ProgComm
 McAllister, David F. [6055A-51]S13
 McCaffery, Shaun F. [6075-17]S5
 McCann, John J. 6057
 ProgComm, [6057-47]S2, [6058-01]S1
 McCarthy, Ann L. [6059-18]S6
 McCarthy, Elizabeth P. [6073-04]S2
 McCarthy, Lawry D. [6075-11]S3
 McCullagh, Barry J. [6063-02]S1
 McDermott, Kyle [6057-43]S3
 McDowall, Ian E. 6055B Chr, 6055B S13 SessChr, 6055B S14 SessChr
 McDowell, David Q. [6059-17]S6
 McGivney, Sinéad [6073-07]S2
 McGruder, Rhoshonda [6055A-12]S3
 McIntire, John P. [6055A-12]S3
 McIntyre, Michelle K. [6055B-66]S13
 McLaughlan, Lifford [6063-32]S5
 McMenemy, Karen R. [6055B-70]S14, [6068-24]S4, [6068-27]S4
 Meessen, Jerome [6056-12]S3
 Meessen, Louis [6068-34]S3
 Megias Jiménez, David [6072-55]S13
 Meguro, Mitsuhiro [6057-36]S13
 Mehrubeoglu, Mehrube [6063-32]S5
 Meisenzahl, Eric J. [6069-02]S1
 Melo, Vinicius [6060-29]S13
 Memon, Nasir D. 6072 S8
 SessChr, 6072 ProgComm, [6072-05]S1
 Mendes, António O. [6056-15]S3
 Menegaz, Gloria [6057-32]S8, [6072-25]S6
 Meng, Jiayuan [6058-40]S9
 Menor Gisbert, Mario [6072-21]S5
 Meriardo, Bernard 6073
 ProgComm, [6073-22]S7
 Meriaudeau, Fabrice 6070 S5
 SessChr, 6070 S6 SessChr, 6070 S1 SessChr, 6070 Chr, [6070-24]S6, [6070-31]S7
 Mérienne, Frédéric [6070-26]S7
 Merritt, John O. SC060 Inst, 6055A Chr, 6055A S3
 SessChr
 Mersereau, Russell M. [6065-20]S7, [6072-46]S11
 Messina, Giuseppe [6061-29]S9
 Messing, Dean S. [6057-16]S5
 Metcalfe, Nigel [6055A-05]S1
 Metikas, Georgios [6064A-05]S1
 Meyer, Greg J. [6056-18]S3
 Miao, Lidan [6069-09]S2
 Miguel, Rui A. [6056-15]S3
 Mikkilineni, Aravind K. [6072-36]S8
 Milanfar, Peyman 6065 S2
 SessChr, 6065 ProgComm, [6065-04]S2, 6077
 ProgComm, [6077-03]S1
 Milazzo, Anna-Clare [6068-26]S4
 Mille, Nicolas [6071-03]S1
 Miller, Eric L. 6065 Chr, 6065 S6 SessChr
 Miller, James R. [6057-17]S6
 Millet, Christophe [6061-13]S5
 Milliard, Bruno [6064A-27]S6
 Min, Byeongwook [6061-35]S10
 Min, Sung-Wook [6055A-54]S13
 Minato, Yuji [6062-13]S4
 Ming, Li [6074-22]S9
 Minghim, Rosane Review, [6060-28]S13, [6060-29]S13
 Minguillón Alfonso, Julià [6061-19]S7, [6072-55]S13
 Mitani, Kohji [6068-09]S2, [6068-25]S4
 Mitra, Sanjit K. [6057-18]S6, [6059-32]S10, 6077
 ProgComm
 Mitrea, Mihai P. [6064A-21]S4
 Mitsui, Hiroko [6056-32]S6
 Mitsui, Masanori [6062-23]S7
 Miyake, Nobuyuki [6055A-14]S3
 Miyake, Yoichi 6059 Chr, 6059 S10 SessChr, [6059-12]S4, 6062
 ProgComm, [6062-13]S4, [6062-18]S5
 Miyamichi, Juichi [6056-31]S6, [6056-33]S6
 Miyasaka, Takeo [6056-29]S6, [6056-34]S6
 Miyata, Kimiyoshi [6062-13]S4, [6062-21]S6
 Miyazawa, Kanae [6062-03]S1
 Mizutani, Naoki [6069-07]S2
 Mobasser, Bijan G. [6072-28]S7, [6072-48]S11
 Moëllic, Pierre-Alain [6061-13]S5
 Mohamed, Magdi A. [6077-31]S6
 Mohamedally, Dean [6074-27]S11
 Molina, Rafael [6077-25]S1
 Molinier, Thierry [6070-10]S3
 Moll, Michael A. [6067-27]S8
 Mondal, Indrasis [6065-32]S9
 Mönich, Ulrich [6077-70]S11
 Montag, Ethan D. [6057-03]S2
 Moodie, Alan R. [6068-03]S1
 Mooney, Christopher [6071-03]S1
 Moreau, Guillaume 6055B
 ProgComm
 Mori, Takanori [6071-10]S3
 Morie, Jacquelyn F. [6055B-74]S15
 Morisawa, Keisuke [6073-06]S2
 Morishita, Akira [6055A-27]S7
 Morita, Huminori [6059-12]S4
 Morita, Toshiya [6077-73]S11
 Moriya, Toshio [6055A-35]S9
 Moroney, Nathan [6058-08]S2, 6059 S2
 SessChr, 6059 ProgComm
 Morris, Hedley C. [6064A-41]S7
 Morris, Robert N. [6070-18]S4
 Morrison, James D. [6068-03]S1
 Morvan, Yannick [6055A-19]S5
 Mörzinger, Roland [6059-35]S10
 Moses, Jeri Anne [6077-24]S4
 Mosquera, Carlos [6072-12]S3
 Motta, Ricardo J. 6069
 ProgComm
 Moulin, Pierre Review, 6072
 ProgComm, 6072 S9
 SessChr, [6072-02]S1, [6072-16]S12, [6072-53]S12
 Mount, David M. 6066 Chr, 6066 S4 SessChr
 Mueller, Klaus D. Review
 Mukherjee, Lopamudra [6066-07]S3
 Müller, Henning [6061-06]S3
 Mulligan, Jeffrey B. 6057
 ProgComm
 Munakata, Tsunestugu [6061-34]S10
 Mündermann, Lars [6056-28]S5
 Munzner, Tamara Review
 Muramatsu, Shogo [6069-07]S2
 Muresan, Leila A. [6070-22]S5
 Murray, Hugh [6055A-40]S11
 Mutelo, Risco M. [6060-14]S6
 Myszkowski, Karol SC772
 Inst, 6057 ProgComm, [6057-05]S2, [6057-23]S6
N
 Naccari, Filippo [6069-12]S3
 Nachtnebel, Herbert [6063-14]S4
 Nadeau, David Review
 Nagata, Shojiro 6055A
 ProgComm, 6055A S8
 SessChr, 6055A S9 SessChr, [6055A-39]S10, 6055B
 ProgComm
 Nagy, George [6067-06]S3
 Nahrstedt, Klara 6071
 ProgComm, [6071-02]S1, [6071-13]S3, [6071-21]S6
 Nair, Dinesh 6070 ProgComm, [6070-15]S4
 Naito, Sei [6077-43]S8, [6077-83]S11
 Nakaguchi, Toshiya [6059-12]S4, [6062-13]S4, [6062-18]S5
 Nakai, Akihito [6055A-53]S13
 Nakajima, Masayuki [6064A-08]S1
 Nakamae, Koji [6065-50]S12
 Nakauchi, Shigeki [6062-03]S1
 Nakaya, Fumio [6062-13]S4
 Nam, Seung-Jin [6055A-55]S4, [6055A-62]S13
 Namiki, Takeshi [6061-25]S8
 Naphade, Milind R. [6061-04]S2
 Napoli, Joshua [6055A-38]S10
 Nartker, Thomas A. 6067
 ProgComm, [6067-19]S6
 Nasrabadi, Nasser M. SC491
 Inst, 6064B Chr, 6064B S11
 SessChr, [6064B-50]S7
 Nassar, Diaa Eldin M. [6064A-26]S5, [6064A-47]S7
 Naveda, Jose F. [6076-08]S2
 Nayar, Shree K. [6077-04]S1
 Neebe, Martin [6075-21]S5
 Nelson, Greg [6067-14]S5
 Neri, Alessandro [6059-40]S11, [6064A-23]S5, [6064A-43]S7
 Netanyahu, Nathan S. 6066
 ProgComm
 Ng, David C. [6068-01]S1
 Ng, Gary [6060-08]S3
 Ng, Tian-Tsong [6072-37]S8
 Ng, Yee S. [6059-19]S6, [6059-20]S6
 Niang, Pierre [6063-18]S4
 Niblock, James H. [6068-24]S4, [6068-27]S4
 Nicholas, Ieuan A. [6055B-68]S14
 ProgComm
 Nichols, David N. [6069-02]S1
 Nicolas, Marina M. [6057-21]S6
 Niel, Kurt S. SC767 Inst, 6070
 Chr, 6070 S2 SessChr, 6070
 S6 SessChr, 6070 S4
 SessChr, [6070-08]S2
 Nieves, Juan L. [6062-09]S3
 Ninassi, Alexandre [6057-08]S4
 Nitta, Naoko [6073-06]S2
 Noamany, Mohammed [6067-24]S8
 Noh, Jung Eun [6068-28]S4
 Nojiri, Yuji [6055A-36]S9, [6068-09]S2, [6068-25]S4
 Noorkami, Maneli [6072-46]S11
 Norcia, Anthony M. [6057-52]S10
 North, Chris Review
 North, Steve Review
 Nosaka, Reina [6077-56]S11
 Novello, Carmine I. D. [6061-23]S7
 Nowak, Robert D. [6065-07]S3
 Numazaki, Shunichi [6055A-27]S7
 Nuño-Maganda, Marco A. [6063-31]S5
 Nunoshita, Masahiro [6068-01]S1, [6068-02]S1, [6068-14]S2
 Nyberg, Sten [6057-29]S7
 Nyman, Gote S. [6055A-10]S3, [6059-02]S1
O
 Oancea, Simona [6062-06]S2

Participants

- Obrador, Pere [6076-06]S1, [6076-10]S2, [6077-86]S11
 Odom, David [6065-04]S2
 Ofner, Ronald [6070-01]S1
 Oggier, Thierry [6056-03]S1
 Ogirala, Mythili [6064A-47]S7
 Oh, Hye Ran [6068-28]S4
 Oh, Hyun-Hwa [6058-16]S4
 Ohashi, Gosuke [6058-45]S9
 Ohki, Tetsushi [6072-20]S4
 Ohta, Jun [6068-01]S1, [6068-02]S1, [6068-14]S2
 Ohta, Keiji [6055A-14]S3
 Ohta, Yukihiko [6068-13]S2
 Ohtsuki, Rie [6062-05]S2
 Ohya, Hiroshi [6064A-11]S2
 Ohyama, Nagaaki [6062-16]S5
 Oikawa, Michio [6055A-35]S9
 Oja, Erkki 6064B ProgComm
 Oja, Joni [6059-02]S1
 Ojanen, Harri J. [6059-02]S1
 Okabe, Kazushige [6055A-47]S13
 Okamoto, Jun [6059-34]S10
 Okamoto, Takashi [6055A-05]S1
 Okano, Fumio [6055A-36]S9
 Okui, Makoto [6055A-36]S9
 Okunaka, Junzo [6061-34]S10
 Okutomi, Masatoshi [6065-49]S12, [6077-40]S7
 O'Leary, Paul L. 6070 ProgComm, [6070-01]S1
 Olhede, Sofia C. [6064A-05]S1
 Olive, Joseph [6067-04]S2
 Olives, Jean-Luc [6059-02]S1
 Olivos-Pérez, Luis I. [6064A-48]S7
 Olijaca, Miki [6075-19]S5
 Olkkonen, Maria [6059-03]S2
 Olsen, Luke [6061-30]S10
 Oltmans, Hans [6075-09]S3
 Olver, Peter [6064A-01]S1
 Olwal, Alex [6055A-45]S12
 Omari, Mohammed [6064B-58]S10
 Onaka, Peter M. [6068-18]S3
 Ooi, Wei-Tsang 6071 ProgComm
 Op de Beeck, Marc [6055A-20]S5
 Ordentlich, Eric [6060-10]S5
 Orio, Nicola [6073-05]S2
 Ortega, Antonio 6077 ProgComm, [6077-09]S2, [6077-89]S4
 Ossonce, Maxime [6072-29]S7
 Ostermann, Jörn 6077 ProgComm
 O'Sullivan, Joseph A. 6065 ProgComm, 6065 S9 SessChr, [6065-29]S9
 Osypiw, David [6063-03]S1, [6074-04]S3
 Otsuki, Masaki [6055A-14]S3
 Oztan, Basak [6058-35]S8
P
 Padula, Marco [6061-33]S10
 Page, David L. [6070-09]S2
 Pagendarm, Hans-Georg 6060 ProgComm
 Pagliarulo, Patrizia [6061-33]S10
 Paik, Jungmin [6066-25]S7
 Pal, Debashish [6065-29]S9
 Pal, Sankar K. 6064B ProgComm
 Paliy, Dmitriy V. [6065-11]S4
 Palola, Marko [6074-26]S10
 Pampaloni, Enrico M. [6062-22]S6
 Pan, Hao [6077-78]S11
 Panchanathan, Sethuraman [6057-39]S13, 6074 ProgComm, 6077 ProgComm
 Pandit, Krishna [6071-09]S2
 Panetta, Karen A. [6064A-28]S6
 Pang, Alex T. 6060 ProgComm
 Panovski, Ljupcho [6077-07]S1
 Papari, Giuseppe [6064A-43]S7
 Papazov, Chavdar [6074-19]S9
 Pappas, Thrasyvoulos N. SympComm, 6057 Chr, [6057-22]S6, [6057-28]S7, 6077 ProgComm
 Parish, David J. [6074-03]S3
 Park, Bosoon [6070-07]S2
 Park, Chang-Joon 6063 ProgComm
 Park, Chang-Seob [6055A-55]S4, [6055A-62]S13
 Park, Du-Sik [6058-16]S4, [6058-20]S5, [6069-14]S4
 Park, Jinah Review
 Park, Jong Ho [6068-13]S2
 Park, Jong Hyun [6064A-37]S1
 Park, Jungwoo [6077-63]S11
 Park, Kee-Hyon [6058-19]S5
 Park, Kwang Suk [6064A-45]S7
 Park, Min-Ho [6077-62]S11
 Park, MinJae [6064A-45]S7
 Park, No Kap [6066-03]S1
 Park, Rae-Hong [6077-59]S11, [6077-62]S11
 Park, Sungjin [6074-24]S10
 Park, Tae-Yong [6058-25]S6
 Parkkinen, Jussi P. [6062-21]S6
 Pascual, Mireia [6061-19]S7
 Pastrana-Vidal, Ricardo R. [6057-20]S6
 Pastrnak, Milan [6077-57]S11
 Patel, Nilesh [6073-38]SA, [6077-75]S11
 Patera, Jiri [6064A-06]S1, [6065-03]S2, [6065-47]S12
 Patria, Andrea D. [6062-22]S6
 Paulovich, Fernando V. [6060-28]S13, [6060-29]S13
 Payne, Janet S. [6057-38]S13
 Pearlman, William A. 6077 ProgComm, 6077 S8 SessChr, [6077-41]S8, [6077-42]S8, [6077-51]S10
 Peck, Charles [6057-26]S7, [6064B-60]S10
 Pei, Shibao [6074-02]S2
 Peker, Kadir A. 6073 ProgComm, [6073-01]S1, [6073-18]S6
 Pelah, Adar 6057 ProgComm
 Peltier, Steve [6068-26]S4
 Pelz, Jeff B. [6057-03]S2
 Peng, Zhu [6077-48]S9
 Penkler, David [6074-17]S7
 Pentikousis, Kostas [6074-26]S10
 Pereda, Ray [6067-19]S6
 Pereira, Fernando M. B. 6077 ProgComm
 Perez, Juan P. [6072-26]S6
 Pérez-Freire, Luis L. [6072-14]S3, [6072-32]S7
 Pérez-González, Fernando 6072 ProgComm, 6072 S3 SessChr, 6072 S12 SessChr, [6072-12]S3, [6072-14]S3, [6072-32]S7
 Perrivell, Jacque [6058-37]S8
 Pesquet-Popescu, Béatrice 6077 ProgComm
 Peters, Frans J. [6055A-22]S6
 Peters, Inge [6068-34]S3
 Peters, John A. [6075-36]S9
 Petkov, Nicolai [6064A-43]S7
 Petrie, Helen [6074-27]S11
 Petrov, Viacheslav V. [6075-40]S10
 Pettifer, Steve [6060-08]S3
 Pevny, Tomas [6072-24]S6
 Pfeiffer, Silvia 6073 ProgComm
 Pfister, Hanspeter [6055A-24]S6
 Pham, Tuan Q. [6077-08]S1
 Phielipp, Mariano [6057-39]S13
 Phillips, Roger [6055A-08]S2
 Phillips, Roger W. 6075 S5 SessChr, 6075 ProgComm, [6075-24]S6, [6075-26]S6
 Plianykh, Oleg S. [6057-10]S4
 Pietariia, Paavo [6074-26]S10
 Pilipaviciute, Egle [6060-30]S14
 Pisanich, Gregory 6063 ProgComm
 Pitsianis, Nikos P. [6065-15]S5
 Piva, Alessandro [6072-27]S7
 Pizlo, Zigmunt SC754 Inst, [6059-27]S8, 6065 ProgComm, 6065 S11 SessChr, [6065-42]S11, [6066-06]S2
 Plaisant, Catherine Review
 Plimmer, Jeremy J. [6075-30]S8
 Poggio, Tomaso A. 6064B ProgComm
 Polderdijk, Frank [6068-34]S3
 Pollak, Ilya 6065 Chr, 6065 S3 SessChr, [6065-02]S2
 Ponomaryov, Volodymyr I. 6063 ProgComm, [6063-16]S4, [6063-22]S5
 Ponte, Isabel [6056-12]S3
 Poppe, Chris [6074-23]S10
 Porikli, Fatih M. 6063 ProgComm, [6063-12]S3, 6077 ProgComm
 Portnoy, Andrew D. [6065-15]S5
 Posse, Christian [6060-22]S10
 Post, Frits H. Review
 Potts, Stephen [6055B-70]S14
 Potts, Travis L. [6075-15]S4
 Power, Vince S. [6055A-44]S12
 Prabhakara, Roopa S. [6068-16]S3
 Prabhakaran, Jayasree K. [6076-05]S1
 Prades-Nebot, Josep [6077-45]S9
 Prasiswa, Jennifer [6072-62]S14
 Prattichizzo, Domenico [6057-32]S8
 Presser, Clifton G. [6060-33]S15
 Prêteux, Françoise J. 6064A ProgComm, [6064A-21]S4
 Preuss, Thomas [6074-20]S9
 Price, Jeffery R. 6070 ProgComm, 6070 S3 SessChr, [6070-18]S4
 Price Jones, Rhys [6076-08]S2
 Priestnall, Gary [6064B-69]S6
 Privitera, Claudio M. [6057-48]S3
 Prusten, Mark J. [6055B-66]S13
 Pryderch, Mark L. [6068-03]S1
 Puech, William [6060-16]S7
 Pulli, Anna [6060-06]S2
 Pujol, Jaume [6062-15]S4
 Pulli, Kari A. 6074 ProgComm, [6074-01]S1
 Pun, Thierry [6072-33]S7, [6072-38]S9, [6072-39]S9, [6072-49]S12, [6072-51]S12, [6073-32]SA, [6073-33]SA
 Purmonen, Juha P. [6062-23]S7
 Purnomo, Budi [6056-14]S3
 Purvis, Lisa 6076 ProgComm
 Putnam, Gloria G. 6068 ProgComm, 6069 ProgComm
Q
 Qi, Hairong [6062-10]S4, [6069-09]S2
 Qi, Xiaojun Review
 Qian, Hui [6077-67]S11
 Qiao, Mu [6076-14]S3
 Qin, Aihong [6066-27]S7
 Qiu, Zhengding [6059-36]S11
 Qu, Wei [6077-31]S6
 Quigley, Aaron Review
 Quyen, Dinh N. [6073-17]S5
R
 Ra, Jong Beom [6055A-21]S5, [6077-87]S11
 Rabbani, Majid SC590 Inst, SC589 Inst, 6077 S5 SessChr, 6077 ProgComm
 Radhakrishnan, Regunathan [6073-01]S1
 Radun, Jenni [6059-02]S1
 Raghavan, Vijay V. [6061-20]S7
 Raglin, Adrienne J. [6072-07]S1
 Rahman, Fuad [6067-18]S5, [6067-20]S6
 Raicu, Daniela S. [6065-48]S12
 Raja, Vinesh H. [6055B-65]S13, [6055B-69]S14
 Rajkumar, Ragunathan 6071 ProgComm
 Rakkolainen, Ismo K. [6055A-45]S12
 Ramachandran, Umakishore [6071-07]S2
 Raman, Neeraja [6076-16]S4
 Ramanath, Rajeev [6069-09]S2
 Ramanathan, Prashant [6077-17]S3
 Rambow, Mark [6074-20]S9
 Ramchandran, Kannan 6077 ProgComm
 Ramoser, Herbert [6070-12]S3
 Ramos-López, Rubén [6064A-48]S7
 Ramponi, Giovanni 6064A ProgComm, [6064A-13]S3
 Ran, Hang [6063-26]S5, [6064B-64]S11
 Rane, Shantanu D. [6077-26]S5
 Rangayyan, Rangaraj M. [6064A-07]S1
 Ranwez, Sylvie [6071-03]S1
 Rao, A. Ravishankar [6057-26]S7
 Rao, A. Ravishankar [6064B-60]S10, 6070 ProgComm
 Rasmussen, Rene 6059 ProgComm, 6059 S4 SessChr, [6059-20]S6
 Raso, James V. [6056-25]S5
 Rathi, Yogesh [6064A-01]S1, [6064B-49]S7, [6064B-51]S7
 Rauterberg, Matthias 6074 ProgComm
 Rawashdeh, Nathir A. [6059-15]S5
 Razdan, Anshuman [6056-19]S4
 Redmil, Dave [6055A-52]S13
 Reeck, David [6074-25]S10
 Rees, Owen [6076-23]S5
 Reeves, Stanley J. 6065 ProgComm, 6065 S10 SessChr, [6065-14]S5, [6065-36]S10
 Regalia, Phillip A. 6074 ProgComm
 Reichart, Daniel [6074-28]S11
 Reinert Nash, John R. 6069 ProgComm, 6069 S5 SessChr
 Reingand, Nadya O. [6075-31]S8
 Reinheimer, Alice L. 6068 ProgComm
 Rejaie, Reza [6071-22]S6
 Relke, Ingo [6055A-26]S7
 Renaud, Ronald [6055A-11]S3, [6055A-49]S13
 Riadh, Tebourbi [6056-37]S6
 Riccardi, Giuseppe [6072-10]S2
 Richards, Dana [6072-23]S6
 Rigling, Brian D. [6056-07]S2
 Riley, Sean [6063-15]S4
 Ring, Daniel [6073-03]S1
 Rinnhofer, Alfred [6070-21]S5
 Riordan, Michael P. [6076-28]S6
 Rising, Hawley K. 6057 ProgComm
 Rivera, Wilson [6076-26]S6
 electronicimaging.org • Tel: +1 703 642 9090 • ei@electronicimaging.org 275

Participants

Rizkalla, Maher [6077-72]S11
 Rizvi, Syed A. 6064B Chr, 6064B S10 SessChr, 6064B S9 SessChr
 Rizzi, Alessandro 6058 ProgComm
 Rizzo, Albert A. [6055A-13]S3
 Ro, Yong Man [6059-37]S11, [6061-32]S10, [6074-06]S3, [6077-79]S11
 Robbins, Kay A. Review, [6060-30]S14
 Robbins, Steven Review
 Roberts, John W. [6057-17]S6
 Roberts, Jonathan C. 6060 Chr
 Röder, Martin [6071-04]S1
 Rodricks, Brian G. 6069 S4 SessChr, 6069 ProgComm, [6069-04]S1
 Rodríguez, Benjamin M. [6072-26]S6
 Rodríguez, Tony F. [6075-34]S9
 Roessler, Peter [6063-14]S4
 Rogers, Yvonne Review
 Rogowitz, Bernice E. 6057 Chr
 Rokita, Przemyslaw [6063-10]S3
 Roman, Audrey [6070-06]S2
 Romano, Afra [6062-22]S6
 Romano, Frank [6076-01]S1
 Romberg, Justin K. [6065-08]S3
 Romero, Javier 6062 S4 SessChr, 6062 ProgComm, [6062-09]S3
 Rondao-Alface, Patrice [6072-57]S13
 Ronen, Udi [6055A-09]S2
 Rosales-Hernández, Victor H. [6063-31]S5
 Rose, Kenneth 6077 ProgComm
 Rosen, Mitchell R. [6057-03]S2, 6062 S7 SessChr, 6062 Chr, [6062-20]S5
 Rossi, Fabio [6055A-02]S1
 Rössler, Roman [6070-08]S2
 Rötzer, Harald [6070-12]S3
 Rui, Yong 6061 ProgComm
 Ruiz-Alzola, Juan [6064A-19]S4
 Rundensteiner, Elke A. [6060-27]S12
 Russo, Cristina Review
 Rytzar, Yuriy B. [6072-38]S9, [6072-49]S12, [6073-32]SA
 Ryu, Byong Tae [6058-30]S7

S
 Saadane, Abdelhakim [6059-05]S2
 Sabria, Pau [6077-45]S9
 Sáenz, Carlos [6062-02]S1
 Safranek, Robert J. 6057 ProgComm
 Saha, Kaushik [6074-11]S6
 Said, Amir 6077 Chr
 Saint Jean, Christophe [6059-28]S9
 Saishu, Tatsuo [6055A-27]S7
 Saito, Suguru [6064A-08]S1
 Saito, Takahiro [6065-37]S10, [6069-05]S1, [6069-08]S2, [6077-56]S11, [6077-73]S11
 Sakaguchi, Yusuke [6055A-47]S13
 Sakamoto, Sayaka [6056-31]S6, [6056-33]S6
 Salama, Paul [6072-43]S10, 6077 ProgComm, 6077 S9 SessChr, [6077-72]S11
 Salvi, Joaquim 6070 ProgComm, [6070-24]S6
 Samadani, Ramin [6058-09]S2
 Samarabandu, Jagath K. 6064A ProgComm
 Sampat, Nitin 6069 Chr, 6069 S6 SessChr
 Sandin, Daniel J. 6055B ProgComm
 Sandom, Chriss [6073-08]S3
 Sangwan, Raghvinder S. 6063 ProgComm
 Sankur, Bülent [6064B-54]S9, [6072-18]S4
 Santini, Simone 6061 Chr, [6061-21]S2
 Santos-Villalobos, Hector J. [6067-15]S5, [6076-12]S3
 Santucci, Giuseppe [6060-21]S10
 Sapiro, Guillermo [6064A-01]S1
 Sapirstein, David [6060-02]S1
 Sarayeddine, Khaled [6059-39]S11
 Sardashti, Somayah [6074-13]S6
 Sarhadi, Mansoor [6064A-46]S7
 Sari-Sarraf, Hamed 6070 ProgComm
 Sarkar, Abhik [6074-11]S6
 Sarkar, Sudeep Review
 Sarkis, Gabi [6073-14]S4
 Sasaki, Masaaki [6068-13]S2
 Sasse, Angela [6074-29]S11
 Sauer, Ken D. [6065-33]S9
 Sawada, Tomonari [6056-04]S1
 Sawchuk, Alexander A. [6055A-13]S3, [6055A-34]S8
 Sbaiz, Luciano M. [6077-02]S1
 Schaede, Johannes G. [6075-02]S1, [6075-06]S2
 Schäfer, Klaus [6075-35]S9
 Schallauer, Peter [6059-35]S10
 Scheidat, Tobias [6072-17]S4
 Scherlen, Anne-Catherine [6057-35]S13
 Schettini, Raimondo 6061 Chr, [6061-18]S6, [6061-36]S7, [6069-12]S3
 Scheuermann, Gerik Review
 Schilling, Andreas [6075-28]S7, [6075-36]S9
 Schirripa Spagnolo, Giuseppe [6075-08]S3
 Schmid, Mathieu [6075-22]S5
 Schmid, Maurizio [6064A-23]S5
 Schmidt-Sacht, Wulf [6058-13]S3
 Schmitt, Jens [6071-09]S2
 Schmucker, Martin [6072-66]S15
 Schoier, Gabriella [6064A-13]S3
 Schojer, Peter [6071-12]S3
 Scholl, Michel [6073-09]S3
 Scholz, Ingo [6077-11]S2
 Schonfeld, Dan [6065-23]S7, 6077 ProgComm, 6077 S6 SessChr, [6077-31]S6, [6077-74]S11, [6077-80]S11
 Schouten, Theo E. [6057-25]S7, [6063-06]S2, [6066-17]S5, [6073-35]SA
 Schrijen, Geert-Jan [6072-19]S4
 Schuberth, Eva [6058-05]S1
 Schuller, Gerald SC764 Inst
 Schulte, Michael J. [6074-12]S6
 Schulz, Elisabeth 6075 S2 SessChr, 6075 ProgComm
 Schumacher, Matthias [6075-35]S9
 Schumann, Heidrun [6074-28]S11
 Schutte, Klamer [6077-08]S1
 Schwan, Karsten 6071 ProgComm
 Schwerdtner, Armin [6055A-28]S7
 Sebe, Nicu SC685 Inst, 6073 S3 SessChr, 6073 Chr, [6073-40]S
 Seidel, Hans-Peter [6055A-24]S6, [6057-05]S2, [6057-23]S6
 Seils, Frank [6075-27]S7
 Seitz, Peter [6056-03]S1
 Seki, Haruyuki [6058-45]S9
 Selesnick, Ivan W. [6077-50]S10
 Sencar, Taha H. [6072-05]S1
 Seo, Jong-Mo [6064A-45]S7
 Seo, Keewon [6074-35]S12
 Seow, Ming-Jung [6064A-32]S6, [6064B-57]S11
 Seran, Vidhya [6077-77]S11
 Serra, Luis [6055A-07]S2
 Serra i Ruiz, Jordi [6072-55]S13
 Setton, Eric [6077-17]S3
 Sezer, Osman G. [6077-05]S1
 Shabatura, Ury V. [6068-32]S
 Shah, Anuj R. [6060-22]S10
 Shah, Jainisha [6075-18]S5
 Shaked, Doron [6058-31]S7
 Shang, Junqing [6067-13]S4
 Shanoylo, Semen M. [6075-40]S10
 Sharma, Gaurav [6058-35]S8, [6065-24]S7, [6065-38]S10, 6072 ProgComm, [6077-36]S6
 Shaw, Christopher D. 6060 ProgComm
 Shaw, Mark Q. [6058-07]S1
 Shaw, Rodney [6058-11]S3
 Shechterman, Mark [6055A-09]S2
 Shekhar, Raj [6063-01]S1, [6063-25]S5
 Shen, Han-Wei Review, [6060-03]S1
 Shen, Jianhong J. [6064A-03]S1
 Shen, Yijiang [6070-16]S4
 Shenias, Haleh H. [6057-24]S7
 Shepherd, John P. [6069-02]S1
 Sheth, Nihar Review
 Shevlin, Fergal P. [6063-02]S1
 Shi, Fei [6077-50]S10
 Shi, Jiaying [6058-40]S9, [6066-27]S7
 Shi, Tuo [6072-43]S10
 Shi, Yun-Qing [6072-15]S3
 Shibata, Takashi [6055A-06]S2, [6055A-14]S3, [6055A-47]S13
 Shih, Chihhsiong [6056-06]S2
 Shiina, Tatsuo [6055A-30]S8
 Shilman, Michael M. [6067-26]S8
 Shim, Simon 6061 ProgComm
 Shima, Tetsuo [6064A-08]S1
 Shima, Yoshihiro [6064A-11]S2
 Shimamoto, Hiroshi [6068-09]S2, [6068-25]S4
 Shimano, Noriyuki [6062-11]S4
 Shimizu, Masao [6077-40]S7
 Shimodaira, Yoshifumi [6058-45]S9
 Shimoyama, Isao [6055A-53]S13
 Shimura, Shogo [6074-31]S11
 Shin, Dong-Ik [6068-28]S4
 Shin, Gun Shik [6064A-35]S7
 Shin, Il-Won [6059-15]S5
 Shnayderman, Aleksandr [6072-74]S16
 Shoji, Kenji [6056-31]S6, [6056-33]S6
 Shterev, Ivo D. [6072-11]S3
 Shu, Yuan [6056-01]S1
 Shulgin, Boris V. [6055B-65]S13, [6055B-69]S14
 Siirtola, Harri Review
 Sikora, Thomas [6055A-23]S6, 6077 ProgComm, [6077-68]S11, [6077-70]S11
 Silva, Alexandre G. [6064A-17]S3
 Silven, Olli J. [6074-07]S4
 Silvestre, Guenole C. M. [6072-30]S7, [6072-31]S7, [6073-04]S2
 Sima, Mihai [6074-12]S6
 Simard, Patrice [6067-26]S8
 Simon, Andreas 6055B ProgComm
 Simon, Klaus [6058-05]S1
 Simon, Larry [6057-17]S6
 Simske, Steven J. [6075-07]S3
 Simunic-Rosing, Tajana 6071 ProgComm
 Sinclair, James [6068-03]S1
 Sinclair, Michael B. [6062-07]S2
 Singh, Vikas [6066-07]S3
 Skourikhine, Alexei N. [6066-05]S1
 Sliwa, Tadeusz M. [6070-20]S5
 Sloan, Kenneth R. Review
 Slobodyan, Vitaliy [6059-08]S3
 Smeaton, Alan F. 6073 ProgComm, 6073 S1 SessChr, [6073-07]S2
 Smirni, Evgenia [6071-18]S5
 Smirnov, Maxim [6069-15]S4
 Smith, John R. 6073 ProgComm
 Smith, Mark J. T. [6065-20]S7
 Smith, Michael A. [6061-17]S6
 Smith, Steven L. 6055A S12 SessChr, 6055A ProgComm
 Smithson, Robert L. [6075-15]S4
 Sneath, Matthew P. [6070-07]S2
 Södergård, Caj [6073-25]S8
 Sohng, Kyu-Ik [6074-36]S12
 Soliman, Hamdy S. [6064B-58]S10
 Someya, Jun [6058-17]S4
 Son, Chang-Hwan [6058-25]S6
 Song, Hwangjun [6077-47]S9
 Song, Kai-Tai [6069-06]S2
 Song, Seokho [6059-30]S9
 Song, Wanqing [6058-45]S9
 Song, Zhan [6070-25]S6
 Soroka, Alexander [6075-41]S10
 Sosa-Ramirez, Gerardo [6063-31]S5
 Soukal, David [6072-41]S9, [6072-68]S16
 Sowizral, Henry A. 6055B ProgComm
 Spannenburg, Sybrand 6075 ProgComm, 6075 S3 SessChr
 Spanner, Matthew P. [6066-12]S4
 Speranza, Filippo [6055A-11]S3, [6055A-49]S13
 Srihari, Sargur N. 6067 ProgComm, [6067-01]S1, [6067-02]S1
 Srinivasan, Harish [6067-02]S1
 St. Clair, Dan [6055B-79]S16
 Stalder, Martin [6075-27]S7
 Stankovic, Vladimir [6072-40]S9
 Startchik, Sergei [6073-32]SA
 Stasko, John Review
 State, Andrei [6055B-77]S16
 Staub, René [6075-28]S7, [6075-36]S9
 Steckert, Jens [6068-35]S3
 Steinbach, Eckehard G. 6077 ProgComm
 Steinebach, Martin [6072-13]S3, [6072-44]S10, [6072-45]S11
 Steinmetz, Ralf 6071 ProgComm, [6071-09]S2, [6071-23]S6
 Stentiford, Fred W. M. [6057-09]S4, [6061-17]S6
 Stevens, Eric G. [6069-02]S1
 Stevenson, Robert L. 6077 S2 SessChr, 6077 ProgComm, [6077-19]S3
 Stiller, Christoph 6070 ProgComm
 Stiller, Peter F. 6066 S5 SessChr, [6066-22]S6
 Stockhammer, Thomas 6077 ProgComm
 Stokman, Harro M. [6061-16]S6

Participants

- Stonham, T. John [6057-38]S13
 Strauch, Reinhard [6074-25]S10
 Strzodka, Robert [6060-01]S1
 Stuijk, Sadner [6077-57]S11
 Stutzbach, Daniel [6071-22]S6
 Subramanian, Kalpathi R. 6060 ProgComm, Review
 Suen, Simon T. [6069-16]S4
 Sugimoto, Osamu [6059-29]S9
 Sugiura, Hiroaki [6058-17]S4
 Sugiyama, Tooru [6058-23]S5
 Sukavanam, Nagarajan [6066-24]S7
 Sukharev, Jeffrey [6060-39]S15
 Sun, Huifang 6077 ProgComm
 Sun, Lifeng [6071-08]S2
 Sun, Limin [6064B-67]S6, [6067-03]S1
 Sun, Ming-Ting 6077 ProgComm
 Sun, Pei-Li [6058-21]S5
 Sun, Peter [6055A-39]S10
 Sun, Qibin [6071-05]S1
 Sun, Shih-Wei [6077-49]S9
 Sun, Yinlong 6060 ProgComm, [6060-02]S1, [6060-35]S15, [6065-39]S11, [6066-26]S7
 Sun, Yong [6072-40]S9
 Sundaram, Hari 6073 ProgComm
 Sundaesan, Aravind [6056-28]S5
 Süssstrunk, Sabine E. 6069 ProgComm, [6077-02]S1
 Suvanaphen, Edward 6060 S13 SessChr, 6060 S7 SessChr
 Suwendi, Ariawan [6076-13]S3
 Swaminathan, Ashwin [6072-64]S15
 Swan, J. E. 6060 ProgComm
 Swiegers, Gerhard F. [6075-11]S3
 Sze, Wui-Fung [6066-09]S3, [6066-19]S6, [6066-20]S6
- T**
 Taghva, Kazem 6067 Chr, [6067-19]S6
 Taguchi, Akira 6064A ProgComm
 Tai, Katsuki [6075-32]S8
 Tai, Yuan C. [6065-29]S9
 Taira, Kazuki [6055A-27]S7
 Takada, Shunji [6068-12]S2
 Takahashi, Chihiro [6057-36]S13
 Takahashi, Hideya [6055A-48]S13, [6056-32]S6
 Takahashi, Hiromi [6065-37]S10
 Takahashi, Yoshihisa [6069-07]S2
 Takaki, Yasuhiro [6055A-32]S8, [6055A-56]S13
 Takala, Jarmo H. 6074 S6 SessChr, 6074 S11 SessChr, 6074 Chr, [6074-05]S3
 Takatalo, Jari [6055A-10]S3
 Takhar, Dharmpal [6065-09]S3
 Takiguchi, Takahiro [6062-13]S4
 Tam, James W. [6055A-11]S3, [6055A-49]S13
 Tan, Andrew M. [6062-24]S7
 Tan, Hong Z. [6057-32]S8
 Tanaka, Kenji [6055A-41]S12
 Tanaka, Masayuki [6065-49]S12
 Tanaka, Toshihisa [6063-23]S5
 Tancharoen, Datchakorn [6073-13]S4
 Tang, Arvin W. [6066-19]S6, [6066-20]S6
 Tanida, Jun [6056-32]S6
 Tanimoto, Masayuki [6055A-31]S8, [6056-36]S6
 Tanizoe, Hideki [6058-17]S4
 Tannenbaum, Allen R. [6064A-01]S1, [6064A-04]S1, [6064B-49]S7, [6064B-51]S7
 Tanushev, Nicolay [6065-19]S6
 Tao, Li [6063-19]S5, [6064A-32]S6, [6064A-44]S7
 Taskiran, Cuneyt M. 6072 S2 SessChr, [6072-09]S2, [6073-19]S6, [6074-08]S5
 Tatani, Keiji [6068-11]S2
 Taylor, Colin J. [6056-16]S3
 Taylor, Russell M. [6060-04]S2
 Te Kolste, Robert D. [6065-15]S5
 Tecchia, Franco [6055A-02]S1
 Tekalp, Ahmet M. 6073 ProgComm
 Telea, Alexandru C. [6060-01]S1
 Telleen-Lawton, David [6061-02]S1
 Tellez, Bruno [6064A-22]S4
 Teranishi, Nobukazu 6068 ProgComm
 Tescher, Andrew G. 6077 ProgComm
 Teutsch, Christian [6070-19]S5
 Thakkar, Nishant [6076-08]S2
 Thang, Truong Cong [6059-37]S11, [6074-06]S3, [6077-79]S11
 Then, Patrick H. H. [6064B-62]S11
 Theuwissen, Albert J. SC760 Inst
 Thibault, Jean-Baptiste [6065-33]S9
 Thiemert, Stefan [6072-44]S10
 Thièvre, Jérôme [6060-26]S12
 Thollot, Julien [6059-39]S11
 Thoma, George R. [6061-22]S7, 6067 ProgComm, [6076-03]S1
 Thomas, Christopher J. [6068-06]S2
 Thomas, Edward [6062-07]S2
 Thon, Sébastien [6060-16]S7
 Tian, Qi 6073 ProgComm
 Tian, Yibin [6069-10]S3
 Tighe, Paul F. [6057-17]S6
- Timlin, Jerilyn A. [6062-07]S2
 Tisato, Francesco [6061-36]S7
 Tjandranegara, Edwin [6073-14]S4
 Tobin, Kenneth W. 6070 ProgComm
 Tocheri, Matthew 6056 Chr, 6056 S4 SessChr
 Tokuda, Takashi [6068-01]S1, [6068-02]S1, [6068-14]S2
 Tominaga, Shoji 6058 ProgComm, [6058-18]S5, 6062 Chr, 6062 S5 SessChr, [6062-05]S2
 Tompkin, Wayne R. 6075 ProgComm, 6075 S6 SessChr, [6075-28]S7, [6075-36]S9
 Tong, Xin [6056-23]S4
 Tong, Yunxia [6065-39]S11, [6066-26]S7
 Tonry, John L. [6068-18]S3
 Topak, Emre [6072-38]S9, [6072-39]S9, [6072-49]S12, [6072-51]S12, [6073-32]SA
 Topkara, Mercan 6072 S2 SessChr, [6072-09]S2, [6072-10]S2
 Tory, Melanie K. Review
 Tost, Dani [6060-06]S2
 Toutant, Jean-Luc [6066-14]S5
 Towers, Simon [6076-07]S2
 Toyama, Fubito [6056-31]S6, [6056-33]S6
 Traisnel, Julien J. [6064A-04]S1
 Trémeau, Alain [6059-39]S11, 6061 ProgComm
 Trifas, Monica A. [6057-10]S4
 Trostmann, Erik [6070-19]S5
 Trouilloud, Pierre [6070-26]S7
 Trovinger, Steven W. [6076-27]S6
 Truchetet, Frédéric [6070-09]S2, [6070-11]S3, [6070-14]S4, [6070-23]S5
 Trujillo San-Martin, Maite [6057-30]S8
 Trutschl, Marjan Review
 Tsai, Chao-Hsu [6075-16]S4
 Tsai, Chiyei [6069-06]S2
 Tse, Kelly [6056-30]S6
 Tseng, Chen-Yu [6069-11]S3
 Tsoupikova, Daria [6055B-73]S15
 Tsubaki, Ikuko [6077-73]S11
 Tsuchida, Masaru [6062-16]S5
 Tsumura, Norimichi [6059-12]S4, 6062 ProgComm, 6062 S6 SessChr, [6062-13]S4, [6062-18]S5
 Tuijn, Chris 6058 ProgComm
 Tuomela, Jukka [6062-23]S7
 Türke, Thomas [6075-02]S1
 Turner, Mark I. [6067-12]S4
 Tuzel, Oncel [6063-12]S3
 Twidale, Michael B. Review
 Tyler, Christopher W. 6057 ProgComm
 Tyler, John M. [6057-10]S4
- U**
 Uchimura, Keiich [6066-02]S1
 Udd, Sture [6073-25]S8
 Ueda, Kumiko [6062-18]S5
 Uehira, Kazutake [6055A-43]S12, [6061-25]S8
 Uematsu, Tsuyoshi [6075-20]S5
 Ukishima, Masayuki [6059-12]S4
 Ukovich, Anna [6064A-13]S3
 Um, Gi-Mun [6055A-50]S13
 Um, Hwayoung [6072-47]S11
 Unno, Hiroshi [6061-25]S8
 Ushinaga, Takeo [6056-04]S1
 Uzuner, Ozlem [6072-08]S2
- V**
 Vadakkumpadan, Fijoy G. [6065-39]S11, [6066-26]S7
 Vahdati, Hamed [6056-22]S4
 Valiquette, Carolyn [6076-24]S6
 Van de Walle, Rik [6074-23]S10
 van den Berg, Jan 6075 ProgComm, [6075-14]S4
 van den Broek, Egon L. [6057-25]S7, [6063-06]S2, [6066-17]S5, [6073-35]SA
 van der veen, Michiel [6072-19]S4, [6072-42]S10, [6072-65]S4
 Van Der Wall, Hans [6056-30]S6
 Van Gool, Luc J. 6061 ProgComm
 van Gorp, Jacco [6077-39]S7
 van Meerbergen, Jef [6077-57]S11
 van Renesse, Rudolf L. SC087 Inst, 6075 Chr, 6075 S9 SessChr, [6075-39]SB
 van Rikxoort, Eva M. [6057-25]S7
 van Vliet, Lucas J. [6077-08]S1
 van Wijk, Jack Review
 Vande Moere, Andrew Review
 Vandewalle, Patrick [6077-02]S1
 Varela-Benitez, Jose L. [6063-22]S5
 Varshney, Amitabh Review
 Varshney, Pramod K. [6064A-29]S6
 Vasudev, Bhaskaran 6077 ProgComm
 Vasudevan, Kirankumar [6076-03]S1
 Veelaert, Peter 6066 ProgComm
 Vega, Fernando [6067-15]S5, 6076 S5 SessChr, 6076 ProgComm, [6076-12]S3
 Velickovski, Filip [6071-03]S1
 Velivelli, Atulya [6073-37]SA
 Veljkovic, Dragana [6060-30]S14
 Venkataraman, Kartik [6069-04]S1
 Venkatasubramanian, Nalini 6071 ProgComm
 Venkatesh, Svetha 6073 ProgComm
 Venters, Colijn C. [6073-11]S3
 Verbeek, Fons J. [6061-14]S5
 Vescovi, Marco [6055A-02]S1
 Vese, Luminita [6065-19]S6
 Vetro, Anthony 6077 ProgComm, [6077-10]S2
 Vetterli, Martin [6077-02]S1
 Vielhauer, Claus SC686 Inst, 6072 ProgComm, 6072 S4 SessChr, [6072-17]S4
 Vila-Forcén, Jose E. [6072-33]S7, [6072-38]S9, [6072-39]S9, [6072-49]S12, [6072-51]S12
 Vilaseca, Meritxell [6062-15]S4
 Villan, Renato [6072-38]S9, [6072-49]S12
 Villanova-Oliver, Marlène [6073-34]SA
 Visengeriyeva, Larysa [6074-25]S10
 Vitali, Fabio [6061-28]S9
 Vitali, Fabio 6076 ProgComm, 6076 S4 SessChr, [6076-22]S5
 Vogel, Thomas [6073-17]S5
 Vogels, Ingrid [6059-09]S3
 Voisin, Sophie [6070-09]S2
 Voisin, Yvon 6070 ProgComm, [6070-20]S5
 Volleberg, Guido [6055A-22]S6
 Voloshynovskiy, Sviatoslav V. 6072 ProgComm, [6072-33]S7, [6072-38]S9, [6072-39]S9, [6072-49]S12, [6072-51]S12, [6073-32]SA
 von der Malsburg, Christoph 6064B ProgComm
 Vondran, Gary L. [6076-06]S1
 Vu, Dzung H. [6056-30]S6
 Vuori, Tero [6059-02]S1, [6059-03]S2
- W**
 Wakamori, Yasuo [6068-13]S2
 Wakin, Michael B. [6065-09]S3
 Wallis, Jillian C. [6076-02]S1
 Walter, Alon [6068-30]S5
 Walworth, Vivian K. 6055A ProgComm, 6055A S4 SessChr
 Wandell, Brian A. [6057-44]S11, [6069-04]S1
 Wang, Beibei [6077-50]S10
 Wang, Chiao [6055A-34]S8
 Wang, Dong [6077-14]S2
 Wang, Fan [6056-01]S1, [6070-03]S1
 Wang, Guisong [6064B-59]S10
 Wang, Haiyun [6057-13]S5
 Wang, Huiqin [6064B-68]S6
 Wang, Huisheng [6077-89]S4
 Wang, Jinshen [6072-11]S3
 Wang, Jinsong [6073-38]SA, [6077-75]S11
 Wang, Lijun [6067-08]S3
 Wang, Ping [6058-41]S9
 Wang, Sheng-Jyh [6066-10]S3, [6069-11]S3, [6070-17]S4
 Wang, Weidong [6074-15]S6
 Wang, Wei-Dong [6074-14]S6
 Wang, Weixing [6063-24]S5, [6064A-36]S7, [6068-29]S4, [6070-27]S7, [6077-66]S11
 Wang, Wiley [6065-02]S2
 Wang, Xianliang [6067-16]S5

Participants

Wang, Xiao Hui [6055A-46]S13
Wang, Ya Peng [6055A-07]S2
Wang, Yang [6062-12]S4
Wang, Yao [6077-50]S10
Wang, Yi [6062-12]S4
Wang, Yiming [6066-04]S1, [6066-15]S5, [6066-18]S5
Wang, Yin Chai [6064B-62]S11
Wang, Ying [6072-02]S1
Wang, Zhiming [6067-08]S3
Ward, Chris 6055A SA SessChr
Ward, Matthew O. Review, [6060-27]S12
Ware, Colin Review
Watanabe, Keishiro [6059-34]S10
Watson, Andrew B. 6057 ProgComm
Weaver, Matthew [6075-34]S9
Webb-Robertson, Bobbie-Jo M. [6060-22]S10
Weber, James [6056-18]S3
Weber, Michael [6070-19]S5
Wee, Susie J. [6074-17]S7
Weeks, Arthur R. SC066 Inst
Wei, Liyang [6065-28]S8
Wei, Xiaohui [6064A-29]S6
Weiskopf, Daniel Review
Weissman, Jonathan S. [6059-08]S3
Weissman, Michael A. 6055A ProgComm, 6055A S2 SessChr
Welch, Greg [6055B-77]S16
Wen, ChaoHua [6070-17]S4
Wen, Chun-Hsiang [6075-16]S4
Wernert, Eric A. Review, [6060-20]S9
Wernick, Miles N. 6065 S8 SessChr, [6065-28]S8, [6065-32]S9
Wessels, Mark A. [6056-09]S3
Westermann, Utz [6074-26]S10
Westhofen, Martin [6055A-06]S2
Westland, Stephen 6062 ProgComm
Wharton, Eric J. [6064A-28]S6
Wheeler, Frederick W. [6065-17]S5
Whitehorn, Mark [6056-10]S3
Whitney, Brian W. [6065-48]S12
Widdowson, Simon [6073-28]S9
Wijnhoven, Rob [6073-26]S8
Wilcock, Reuben [6068-15]S3
Wilhelms, Jane Review
Williams, Don R. SC513 Inst, [6059-22]S7
Williams, Scott SC759 Inst
Windham, William R. [6070-07]S2
Wittebrood, Rimmert [6077-39]S7
Wittenbrink, Craig M. 6060 ProgComm
Wolf, Franziska [6072-17]S4
Wolf, Lars 6071 ProgComm

Wong, Hau-san [6056-23]S4
Wong, Kenneth K. [6069-16]S4, [6069-19]S5
Wong, Kwok Y. [6069-02]S1
Wong, Pak C. 6060 S3 SessChr, 6060 CoChr, [6060-09]S4
Wong, Ping Wah 6072 S7 SessChr, 6072 Chr
Wong, Stephen T. C. 6073 ProgComm
Wong, Tak-Shing [6065-02]S2
Woo, Wai L. [6060-14]S6
Wood, Brian [6060-15]S7
Wood, Zoe [6060-15]S7
Woods, Andrew J. SympComm, SC060 Inst, 6055A Chr, 6055A S13 SessChr, 6055A S11 SessChr, 6055A SA SessChr, 6055A S1 SessChr
Woods, John W. SC763 Inst, 6077 S10 SessChr, 6077 ProgComm, [6077-52]S10
Worring, Marcel 6073 ProgComm
Wright, Cameron H. G. [6068-16]S3
Wu, Angela Y. 6066 Chr
Wu, Chia-Hao [6070-28]S7
Wu, Feng [6077-29]S5, [6077-30]S5, [6077-54]S10
Wu, Gang [6071-24]S6
Wu, Heyu [6065-29]S9
Wu, Min 6072 S15 SessChr, 6072 ProgComm, [6072-35]S8, [6072-64]S15
Wu, Xiaodong 6066 ProgComm
Wu, Yifeng [6058-32]S7
Wu, Yongjun [6077-52]S10
Wu, Yunsong [6063-21]S5
Wu, Zheng [6077-67]S11
Wueller, Dietmar SC753 Inst, [6069-20]S6, [6069-25]S7

X
Xia, Song [6056-38]S6
Xiao, Feng 6063 ProgComm, [6069-23]S7
Xiao, Yingcai 6060 ProgComm
Xiao, Yongqin [6066-23]S6
Xin, Jun [6077-10]S2
Xing, Liyuan [6073-20]S6
Xing, Yuxiang [6064A-25]S5, [6065-35]S9, [6067-08]S3
Xiong, Hongkai [6077-54]S10
Xiong, Weihua [6057-04]S2, [6058-22]S5
Xiong, Zixiang [6072-40]S9
Xu, Dongyan 6071 ProgComm
Xu, Jinhui [6066-07]S3
Xu, Jizheng [6077-54]S10
Xu, Xinyu [6077-32]S6
Xue, Feng [6056-24]S4
Xue, Juntao [6058-41]S9
Xuong, Nguyen-Huu [6068-26]S4

Y
Yabuta, Kenichi [6063-23]S5
Yadid-Pecht, Orly 6068 ProgComm
Yamada, Kenji [6055A-48]S13, [6056-32]S6
Yamada, Yasuyuki [6065-50]S12
Yamaguchi, Masahiro 6062 S3 SessChr, [6062-16]S5, [6062-23]S7
Yamamoto, Akio [6068-02]S1
Yamamoto, Atsuhiko [6068-11]S2
Yamamoto, Shinya [6068-14]S2
Yamamoto, Shoji [6062-18]S5
Yamasaki, Masami [6055A-35]S9
Yamasaki, Toshihiko [6073-13]S4
Yamashita, Takayuki [6068-09]S2, [6068-25]S4
Yamazaki, Masayuki [6057-06]S3
Yamazoe, Takashi [6055A-06]S2, [6055A-47]S13
Yamrom, Boris Review
Yanagawa, Noriyuki [6059-12]S4
Yanaka, Kazuhisa [6061-25]S8
Yang, Baofen [6066-01]S1
Yang, ChanSeok [6074-24]S10
Yang, Ijiang [6075-21]S5
Yang, Ming Yuan [6077-58]S11
Yang, Yang [6072-40]S9
Yang, Yongyi 6065 ProgComm, [6065-28]S8, [6065-32]S9
Yang, Zhenyu [6071-02]S1
Yanikoglu, Berrin A. 6067 ProgComm
Yao, Qingdong [6074-14]S6, [6074-15]S6, [6074-42]S12
Yaron, Avi [6055A-09]S2
Yaroslavsky, Leonid P. [6056-11]S3
Yasuda, Hiroshi [6073-10]S3
Yasui, Ryota [6055A-33]S8
Ye, Jilin [6055B-65]S13, [6055B-69]S14
Ye, Jong Chul [6065-26]S8
Ye, Qixiang [6073-20]S6
Yea, Sehoon [6077-41]S8, [6077-51]S10
Yeh, Shih-Chin [6055A-13]S3
Yemez, Yucel [6072-18]S4
Yendo, Tomohiro [6055A-31]S8, [6056-36]S6
Yin, Gongjie [6056-41]S6
Yin, I-Chieh [6069-11]S3, [6070-17]S4
Yin, Yong [6073-31]SA
Ying, Yibin [6056-39]S6
Yinnerman, Anders Review
Yokoyama, Hiroshi [6055B-67]S14

Yoo, Suk In [6066-03]S1
Yoon, Ilmi Review, [6061-12]S4
Yoshihara, Yoshihiro [6055A-14]S3
You, Jane [6064A-16]S3
Young, Douglas J. [6068-18]S3
Yu, Chao [6077-36]S6
Yu, Guojun [6074-42]S12
Yu, Guoqiang [6064A-25]S5
Yu, Hua [6073-20]S6
Yu, Young S. [6055A-55]S4
Yuan, Wanghong 6071 ProgComm
Yun, Jungil [6074-36]S12
Yun, Kugin [6055A-59]S13
Yurcik, William J. 6060 ProgComm, [6071-02]S1

Z
Zacchigna, Alessandra [6064A-13]S3
Zaphiris, Panayiotis [6074-27]S11
Zaratsyan, Artak [6064A-06]S1, [6065-03]S2
Zavorin, Ilya [6067-12]S4
Zeise, Eric K. 6059 ProgComm, 6059 S6 SessChr, [6059-16]S5
Zeiter, Daniel [6058-05]S1
Zelkowitz, Evan [6073-14]S4
Zeng, HuanZhao [6058-04]S1
Zeng, Wenjun [6077-48]S9
Zhang, Aidong 6073 ProgComm
Zhang, Bo [6061-07]S3
Zhang, Chun-e [6059-36]S11
Zhang, Fangming [6056-39]S6
Zhang, Guanjun [6077-19]S3
Zhang, Ji [6065-22]S7
Zhang, Jian Review
Zhang, Jie [6055B-64]S13
Zhang, Jin [6064A-25]S5
Zhang, Li [6064A-25]S5, [6065-35]S9, [6067-08]S3
Zhang, Michael Y. [6061-30]S10
Zhang, Qi [6071-18]S5
Zhang, Xiaoli [6067-07]S3, [6067-25]S8
Zhang, Zhe [6055A-51]S13
Zhao, Shanyu [6071-22]S6
Zhao, Yang [6070-04]S1
Zheng, Haitao 6074 ProgComm
Zheng, Yibin 6065 ProgComm
Zheng, Yili [6065-10]S4
Zhong, Yuzhuo [6071-08]S2
Zhong, Zhong [6065-32]S9
Zhou, Luping [6055A-07]S2
Zhu, Guangxi [6077-64]S11
Zhu, Guangyu [6067-09]S4, [6067-11]S4

Zhu, Hongmei [6064A-06]S1
Zhu, Miaoliang [6077-67]S11
Zhu, Ying [6071-11]S3
Zhu, Yixuan [6056-38]S6
Zhu, YongWei [6071-05]S1
Ziad, Belhadj [6056-37]S6
Zimmermann, Roger 6071 ProgComm, 6071 SA SessChr, [6071-16]S5
Zinger, Sviltana [6061-13]S5
Zink, Michael 6071 ProgComm
Ziou, Djemel [6066-21]S6
Zlatoff, Nicolas [6064A-22]S4
Zmudzinski, Sascha [6072-13]S3
Zolliker, Peter [6058-05]S1
Zoltner, Susan [6059-20]S6
Zomet, Assaf [6077-04]S1
Zonta, Gianluca [6061-28]S9
Zuffi, Silvia [6061-10]S4, [6061-11]S4
Zuk, Torre D. [6060-07]S3
Zuo, Fei [6072-19]S4
Zuo, Yuanyuan [6061-07]S3
Zurada, Jacek M. 6064B ProgComm

Publication Order Form

IS&T/SPIE Member IS&T/SPIE ID #

First Name	M.I.	Last Name
Title		
Company		
Address (include Mail Stop)		
City	State/Province	Zip/Postal Code
Country other than USA		
Phone	Fax	
E-Mail Address (IS&T/SPIE does not sell e-mail addresses)		Date of Birth (Optional)

For Office Use Only

Date _____

Amt. Recd. _____

CC Cash Check TC

Check # _____

P.O. # _____

IDN # _____

ORD # _____

Check this box if you do not wish to receive information from organizations other than IS&T/SPIE.

Proceedings and Publications

Fill in the volume or order number(s) and price(s) of the publications you wish to order below.

QTY.	VOL NO.	TITLE	PRICE (USD)

PUBLICATIONS TOTAL
\$ _____ USD

CA, FL, WA residents add sales tax; Canadian residents must add GST \$ _____ USD

Shipping/Handling (Books & CD-ROMs) \$ _____ USD

U.S. 5% of order total [2-3 weeks delivery] Elsewhere 10% of order total [3-5 weeks delivery]

Express Shipping: U.S. \$15 USD for 1st item; \$10 USD each addl item [2-3 days delivery]

Elsewhere \$30 USD for 1st item; \$15 USD each addl item [1 week delivery]

SUBTOTAL
\$ _____ USD

Method of Payment

Check enclosed. Payment in U.S. dollars (by draft on a U.S. bank or international money order) is required. Do not send currency. Wire transfers from banks must include a copy of the transfer order.

Charge to my: VISA MasterCard Discover American Express Diners Club

Card Number _____

Expiration date _____

Signature _____

Purchase order enclosed (Purchase orders must be preapproved).

All orders must be PREPAID in U.S. dollars. Prices subject to change without notice. No returns without written authorization of IS&T/SPIE. ITEMS WILL NOT BE SHIPPED UNLESS PAYMENT IS RECEIVED.

TOTAL

\$ _____ USD

Proceedings

Electronic Imaging

Science and Technology

Order Proceedings volumes now and receive low prepublication prices

Vol#	Title (Editor)	Prepublication Price	Vol#	Title (Editor)	Prepublication Price
6055	Stereoscopic Displays and Virtual Reality Systems XIII (A. J. Woods/J. O. Merritt/N. A. Dodgson/M. T. Bolas/I. E. McDowall)	\$100	6070	Machine Vision Applications in Industrial Inspection XIV (F. Meriaudeau/K. S. Niel)	\$60
6056	Three-Dimensional Image Capture and Applications VII (B. D. Corner/P. Li/M. Tocheri)	\$70	✓ 6071	Multimedia Computing and Networking 2006 (S. Chandra/C. Griwodz)	\$53
6057	Human Vision and Electronic Imaging XI (B. E. Rogowitz/T. N. Pappas/S. J. Daly)	\$70	6072	Security, Steganography, and Watermarking of Multimedia Contents VIII (E. J. Delp III/P. Wong) ...	\$100
✓ 6058	Color Imaging XI: Processing, Hardcopy, and Applications (R. Eschbach/G. G. Marcu)	\$70	✓ 6073	Multimedia Content Analysis, Management, and Retrieval 2006 (E. Y. Chang/A. Hanjalic/N. Sebe)	\$60
✓ 6059	Image Quality and System Performance III (Y. Miyake/L. C. Cui)	\$70	6074	Multimedia on Mobile Devices II (R. Creutzburg/J. H. Takala/C. Chen)	\$70
✓ 6060	Visualization and Data Analysis 2006 (R. F. Erbacher/J. C. Roberts/M. T. Gröhn/K. Börner)	\$70	6075	Optical Security and Counterfeit Deterrence Techniques VI (R. L. van Renesse)	\$70
✓ 6061	Internet Imaging VII (S. Santini/R. Schettini/T. Gevers)	\$60	6076	Digital Publishing (J. P. Allebach/H. Chao)	\$53
✓ 6062	Spectral Imaging: Eighth International Symposium on Multispectral Color Science (M. R. Rosen/F. H. Imai/S. Tominaga)	\$53	✓ 6077	Visual Communications and Image Processing 2006 (J. G. Apostolopoulos/A. Said)	\$105
6063	Real-Time Image Processing 2006 (N. Kehtarnavaz/P. A. Laplante)	\$60			
6064	Image Processing: Algorithms and Systems, Neural Networks, and Machine Learning (E. R. Dougherty/J. T. Astola/K. O. Egiazarian/N. M. Nasrabadi/S. A. Rizvi) ..	\$90			
6065	Computational Imaging IV (C. A. Bouman/E. L. Miller/I. Pollak)	\$80			
✓ 6066	Vision Geometry XIV (L. Latecki/D. M. Mount/A. Y. Wu)	\$60			
✓ 6067	Document Recognition and Retrieval XIII (K. Taghva/X. Lin)	\$53			
6068	Sensors, Cameras, and Systems for Scientific/Industrial Applications VII (M. M. Blouke)	\$60			
6069	Digital Photography II (N. Sampat/J. M. DiCarlo/R. A. Martin)	\$53			

✓ Indicates volumes that will be available at the meeting. Other Proceedings will be available an average of 6-8 weeks after the meeting.

Order online!

www.electronicimaging.org

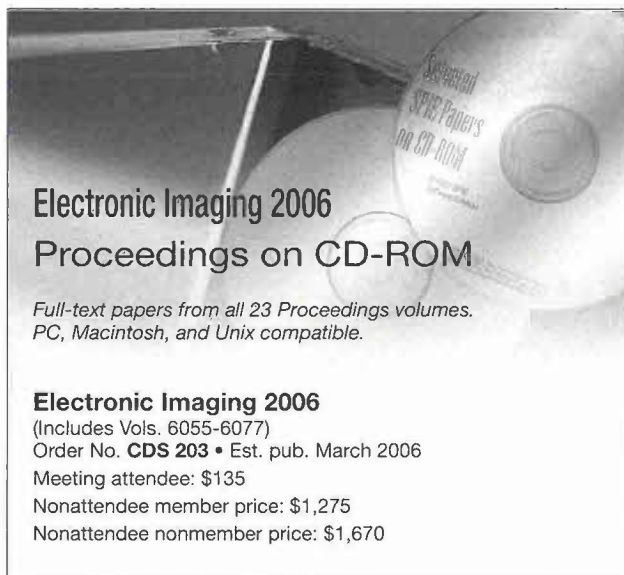

Electronic Imaging 2006
Proceedings on CD-ROM

*Full-text papers from all 23 Proceedings volumes.
PC, Macintosh, and Unix compatible.*

Electronic Imaging 2006
(Includes Vols. 6055-6077)
Order No. **CDS 203** • Est. pub. March 2006
Meeting attendee: \$135
Nonattendee member price: \$1,275
Nonattendee nonmember price: \$1,670



imaging.org

*your one-stop source
for imaging science & technology*

- ▲ *conferences*
- ▲ *publications*
- ▲ *networking*
- ▲ *information*

In addition to discounts on conference registrations, tutorials, and products, IS&T members get unlimited access to all IS&T conference papers (with the exception of EI).

join today

SPIE Membership

Your Resource. Your Society.

Information is increasingly a source of competitive advantage. Through face-to-face interaction, publications and online resources, you gain more from your membership in SPIE.

Join today.
spie.org/membership

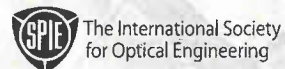

Tel: +1 360 676 3290 • spie@spie.org



Real-time events. Real-world innovation.

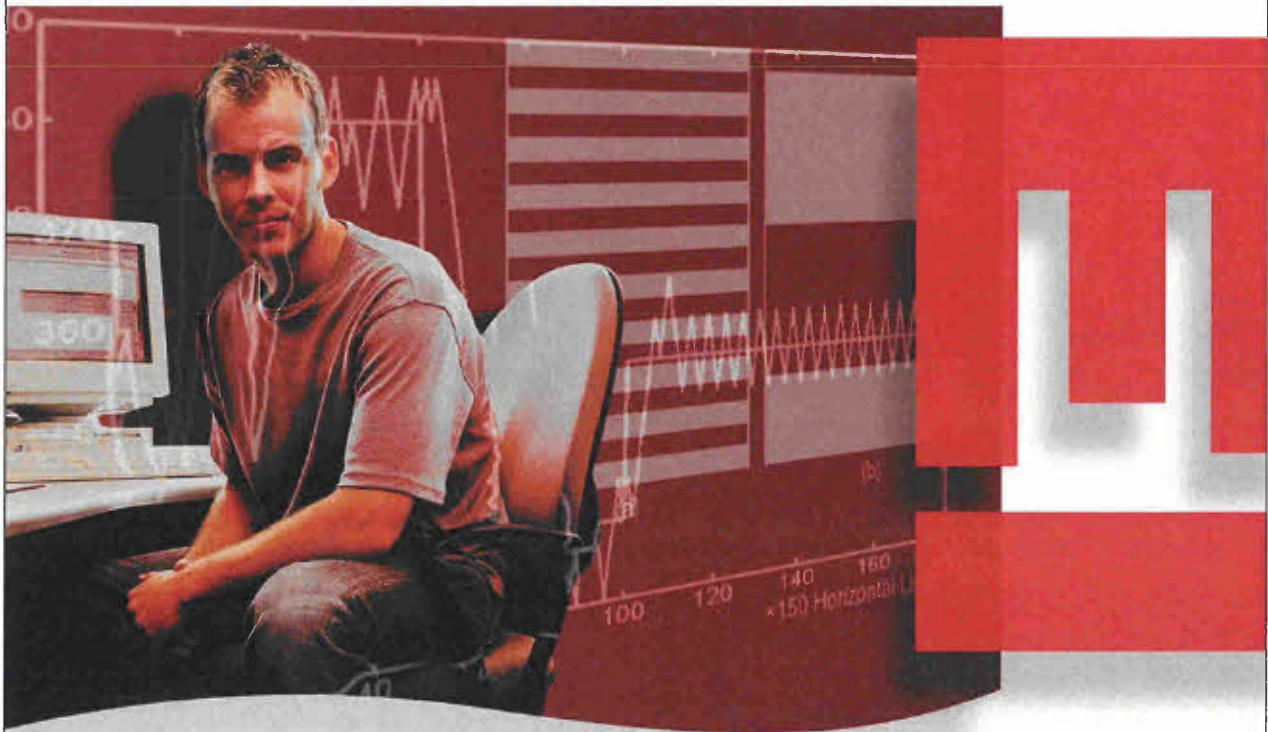

Participate in this focused event for the imaging community. Hear unpublished research from other engineers, scientists, researchers, and managers. Meet the leaders in the field—an opportunity that you get only by attending Electronic Imaging 2006.

IS&T/SPIE 19th Annual Symposium

Electronic Imaging

Science and Technology

28 January–1 February 2007

San Jose Convention Center
San Jose, California USA

Conferences • Courses • Exhibition

electronicimaging.org

IS&T—The Society for Imaging Science and Technology • +1 703 642 9090 • info@imaging.org
SPIE—The International Society for Optical Engineering • +1 360 676 3290 • spie@spie.org

IS&T/SPIE 18th Annual Symposium **Electronic Imaging Science and Technology** • 15-19 January 2006 • San Jose, California USA

Libraries that Own Item [Ask A Librarian](#)

• This screen shows libraries that own the item you selected.

[Home](#) | [Databases](#) | [Searching](#) | [Results](#) | [Staff View](#) | [My Account](#) | [Options](#) | [Comments](#) | [Exit](#) | [Hide tips](#)

[List of Records](#) | [Detailed Record](#) | [Marked Records](#) | [Saved Records](#) | Go to page

Current database: **WorldCat** Total Libraries: 24 

Title: Multimedia on mobile devices II : 16-17 January 2006, San Jose, California, USA **Author:** Creutzburg, Reiner **Accession Number:** 65219184

Libraries with Item: "Multimedia on mobile devi..." ([Record for Item](#) | [Get This Item](#))

Location	Library	Local Holdings	Code
US,AL	REDSTONE SCI INFO CTR		MWF
US,CO	UNIV OF COLORADO AT DENVER, AURARIA LIBR	Local Holdings Availa...	COA
US,DC	LIBRARY OF CONGRESS		DLC
US,GA	GEORGIA INST OF TECH		GAT
US,MA	MASSACHUSETTS INST OF TECH		MYG
US,MA	UNIV OF MASSACHUSETTS AMHERST		AUM
US,MD	UNIV OF MARYLAND, COL PARK	Local Holdings Availa...	UMC
US,MN	UNIV OF MINNESOTA, MINNEAPOLIS		MNU
US,MO	LINDA HALL LIBR		LHL
US,NC	BAKER & TAYLOR INC TECH SERV & PROD DEV		BTCTA
US,NC	NORTH CAROLINA STATE UNIV		NRC
US,NH	YBP LIBRARY SERVICES		YDX
US,NY	CORNELL UNIV	Local Holdings Availa...	COO
US,OH	AF RESEARCH LAB LIBR		SCW
US,TX	TEXAS A&M UNIV		TXA
US,TX	TEXAS A&M UNIV JOINT LIBR STORAGE FAC		TXLFF
US,WA	WASHINGTON STATE UNIV		NTE
CA,ON	NATIONAL RES COUN OF CANADA		CAI
CA,ON	ONTARIO COLLEGES LIBR SERV		B9B
CA,ON	UNIV OF ONTARIO INST OF TECHNOL		CAUOI
CA,QC	CONCORDIA UNIV LIBR		CDN
Taiwan	NATIONAL TAIWAN UNIV		NTU
United Kingdom	BRITISH LIBR		BRI
United Kingdom	BRITISH LIBR REFERENCE COLLECTIONS		BLSTP

Record for Item: "Multimedia on mobile devi..." ([Libraries with Item](#))

[GET THIS ITEM](#)

Access: <http://catdir.loc.gov/catdir/toc/fv0706/2006285636.html>

Availability: **Check the catalogs in your library.**

- [Libraries worldwide that own item:](#) 24
-  [Search the catalog at the Library of University of Illinois at Urbana-Champaign](#)

External Resources:

-  [Discover UIUC Full Text](#)
- [Interlibrary Loan Request](#)
- [Cite This Item](#)

FIND RELATED

More Like This: [Search for versions with same title and author](#) | [Advanced options ...](#)

Find Items About: [Society of Photo-optical Instrumentation Engineers.](#) (40)

Title: **Multimedia on mobile devices II :**
16-17 January 2006, San Jose, California, USA /

Author(s): [Creutzburg, Reiner . 1953-](#)
[Takala, Jarmo .](#)
[Chen, Chang Wen . 1959-](#)

Corp Author(s): [IS & T--the Society for Imaging Science and Technology .](#) ; [Society of Photo-optical Instrumentation Engineers.](#)

Publication: Bellingham, Wash. : SPIE , Springfield, Va : IS & T,
Year: 2006

Description: 1 volume (various pagings) : illustrations ; 28 cm.

Language: English

Series: SPIE ;; vol. 6074; Proceedings of electronic imaging science and technology; **Variation:** Proceedings of SPIE--the International Society for Optical Engineering ;; v. 6074.; Electronic Imaging Science and Technology Symposium.; Proceedings of Electronic Imaging Science and Technology.

Attachment 1f: Statewide Illinois Library Catalog record for the January 2006 SPIE/IS&T conference in San Jose

Standard No: **ISBN:** 0819461148; 9780819461148; **National Library:** 013469004; **LCCN:** 2006-285636

Access: **Materials specified:** Table of contents <http://catdir.loc.gov/catdir/toc/fy0706/2006285636.html>

SUBJECT(S)

Descriptor: [Multimedia systems -- Congresses](#)
[Multimedia communications -- Congresses](#)
[Multiprocessors -- Congresses](#)
[Wireless communication systems -- Congresses](#)
[Multimedia communications](#)
[Multimedia systems](#)
[Multiprocessors](#)
[Wireless communication systems](#)

Genre/Form: [Conference papers and proceedings](#)

Note(s): Includes bibliographical references and author index.

Class Descriptors: LC: [QA76.575](#); [TA1505](#); **Dewey:** [006.7](#)

Other Titles: Electronic imaging science and technology

Responsibility: Reiner Creutzburg, Jarmo H. Takala, Chang Wen Chen, chairs/editors ; sponsored by IS & T--the Society for Imaging Science and Technology [and] SPIE--the International Society for Optical Engineering.

Vendor Info: Baker and Taylor YBP Library Services (BTCP YANK)

Material Type: Conference publication (cnp); Internet resource (url)

Document Type: Book; Internet Resource

Date of Entry: 20060328

Update: 20150805

Accession No: **OCLC:** 65219184

Database: WorldCat



Current database: **WorldCat** Total Libraries: 24



[English](#) | [Español](#) | [Français](#) | [عربي](#) | [日本語](#) | [한국어](#) | [中文\(繁體\)](#) | [中文\(简体\)](#) | [Options](#) | [Comments](#) | [Exit](#)

IS&T/SPICE 10th Annual Symposium

Electronic Imaging

Science and Technology

15-19 January 2006, San Jose, California, USA

[IS&T Home](#) | [SPIE Home](#)

ELECTRONIC IMAGING

REGISTER CONFERENCES EXHIBITION SHORT COURSES SPECIAL EVENTS TRAVEL/GENERAL PROCEEDINGS AUTHOR INFO CHAIR INFO

DETAILS

- [Invitation to Participate](#)
- [Technical Organizing Committee](#)
- [Participants](#)
- [Symposium Demonstration Session](#)
- [Media & Publicity](#)
- [200-Word Final Summary Submission Guidelines](#)
- [Proceedings Guidelines](#)
- [Copyright Transfer Form \(PDF\)](#)
- [Letters of Invitation for Visa Process](#)
- [Printed Final Program \(1MB PDF\)](#)
- [Printed Advance \(815K PDF\)](#)
- [Printed Call for Papers \(645K PDF\)](#)

ELECTRONIC IMAGING

- [Register](#)
- [Conferences](#)
- [Exhibition](#)
- [Short Courses](#)
- [Special Events](#)
- [Travel/General](#)
- [Proceedings](#)
- [Author Info](#)
- [Chair Info](#)

Proceedings

ELECTRONIC IMAGING 2006

Electronic Imaging 2006 Proceedings on CD-ROM

Full-text papers from all 23 Proceedings volumes. PC, Macintosh, and Unix compatible.

Electronic Imaging 2006
(Includes Vols. 6055-6077)
Order No. CDS203 · Est. pub. March 2006
Meeting attendee: \$135
Nonattendee member price: \$1,115
Nonattendee nonmember price: \$1,460

Order Proceedings volumes now and receive low prepublication prices

* Indicates volumes that will be available at the meeting. Other Proceedings will be available an average of 6-8 weeks after the meeting.

Vol#	Title (Editor)	Prepublication price
6055	Stereoscopic Displays and Virtual Reality Systems XIII (A. J. Woods/J. O. Merritt/N. A. Dodgson/M. T. Bolas/I. E. McDowall)	\$100
6056	Three-Dimensional Image Capture and Applications VII (B. D. Corner/P. Li/M. Tocheri)	\$70
6057	Human Vision and Electronic Imaging XI (B. E. Rogowitz/T. N. Pappas/S. J. Daly)	\$70
6058*	Color Imaging XI: Processing, Hardcopy, and Applications (R. Eschbach/G. G. Marcu)	\$70
6059*	Image Quality and System Performance III (Y. Miyake/L. C. Cui)	\$70
6060*	Visualization and Data Analysis 2006 (R. F. Erbacher/ J. C. Roberts/M. T. Gröhn/K. Börner)	\$70
6061*	Internet Imaging VII (T. Gevers/S. Santini/R. Schettini)	\$60
6062*	Spectral Imaging: Eighth International Symposium on Multispectral Color Science (M. R. Rosen/F. H. Imai/S. Tominaga)	\$53
6063	Real-Time Image Processing 2006 (N. Kehtarnavaz/P. A. Laplante)	\$60
6064	Image Processing: Algorithms and Systems, Neural Networks, and Machine Learning (E. R. Dougherty/J. T. Astola/K. O. Egiazarian/N. M. Nasrabadi/S. A. Rizvi)	\$90
6065	Computational Imaging IV (C. A. Bouman/ E. L. Miller/I. Pollak)	\$80
6066*	Vision Geometry XIV (L. Latecki/D. N. Mount/A. Y. Wu)	\$60
6067*	Document Recognition and Retrieval XIII (K. Taghva/X. Lin)	\$53
6068	Sensors, Cameras, and Systems for Scientific/ Industrial Applications VII (M. M. Blouke)	\$60
6069	Digital Photography II (N. Sampat/J. M. DiCarlo/R. A. Martin)	\$53
6070	Machine Vision Applications in Industrial Inspection XIV (F. Meriaudeau/K. S. Niel)	\$60
6071*	Multimedia Computing and Networking 2006 (S. Chandra/C. Griwodz)	\$53
6072	Security, Steganography, and Watermarking of Multimedia Contents VIII (E. J. Delp III/P. Wong)	\$100
6073*	Multimedia Content Analysis, Management, and Retrieval 2006 (E. Y. Chang/A. Hanjalic/N. Sebe)	\$60
6074	Multimedia on Mobile Devices II (R. Creutzburg/ J. H. Takala/C. Chen)	\$70
6075	Optical Security and Counterfeit Deterrence Techniques VI (R. L. van Renesse)	\$70
6076	Digital Publishing (J. P. Allebach/H. Chao)	\$53
6077*	Visual Communications and Image Processing 2006 (J. G. Apostolopoulos/A. Said)	\$105

* Indicates volumes that will be available at the meeting. Other Proceedings will be available an average of 6-8 weeks after the meeting.

PLAN YOUR WEEK

- [Daily Conference Schedule](#)
- [Short Courses Schedule](#)

IMPORTANT DATES

- Conference Dates:** 15-19 January 2006
- Pre-registration Due:** 15 December 2005
- Hotel Reservations Due:** 15 December 2005
- Final Summaries Due:** 14 November 2005
- Manuscripts Due:** 19 December 2005
- On-site Proceedings Manuscripts Due:** 24 October 2005

SPONSORED BY



| [IS&T Home](#) | [SPIE Home](#) |

+1 703 642 9090 | +1 360 676 3290

© 1994-2006 IS&T and SPIE