

08/567224  
 Class  
 Subclass  
 ISSUE CLASSIFICATION



UTILITY SERIAL NUMBER 08/567224	PATENT DATE	PATENT NUMBER
SERIAL NUMBER 08/567,224	FILING DATE 12/04/95	CLASS 427 216
SUBCLASS 21	GROUP ART UNIT 112 1802	EXAMINER Loring

APPLICANTS DANIEL L. FLAMM, WALNUT CREEK, CA; GEORGY VINOGRADOV, YAMANASHI, JAPAN; SHIMAD YONEYAMA, YAMANASHI, JAPAN.

\*\*CONTINUING DATA\*\*\*\*\*  
 VERIFIED

*none*  
*DL*

*etching*  
*1109*

\*\*FOREIGN/PCT APPLICATIONS\*\*\*\*\*  
 VERIFIED

*none*  
*DL*

FOREIGN FILING LICENSE GRANTED 06/22/96

*2 Signatures Required on Response*

Foreign priority claimed 35 USC 119 conditions met	<input type="checkbox"/> yes <input type="checkbox"/> no	<input type="checkbox"/> yes <input type="checkbox"/> no	AS FILED →	STATE OR COUNTRY CA	SHEETS DRWGS. 13	TOTAL CLAIMS 20	INDEP CLAIMS 3	FILING FEE RECEIVED \$220.00	ATTORNEY'S DOCKET NO. 16655-000300
---	---	---	---------------	------------------------	---------------------	--------------------	-------------------	---------------------------------	---------------------------------------

Verified and Acknowledged  
 Examiner's Initials  
 RICHARD T OGAWA  
 TOWNSEND & TOWNSEND & CREW  
 TWO EMBARCADERO CENTER 8TH FLOOR  
 SAN FRANCISCO CA 94111

TITLE PROCESS DEPENDING ON PLASMA DISCHARGES SUSTAINED BY INDUCTIVE COUPLING

U.S. DEPT. of COMMERCE • Patent and Trademark Office-PCT-436L (rev. 7-94)

PARTS OF APPLICATION FILED SEPARATELY		Applications Examiner	
NOTICE OF ALLOWANCE MAILED		CLAIMS ALLOWED	
Assistant Examiner		Total Claims	Print Claim
		DRAWING	
ISSUE FEE	Primary Examiner	Sheets Drwg.	Figs. Drwg.
Amount Due		Date Paid	Print Fig.
Label Area		ISSUE BATCH NUMBER	
		PREPARED FOR ISSUE	
WARNING: The information disclosed herein may be restricted. Unauthorized disclosure may be prohibited by the United States Code Title 35, Sections 122, 181 and 368. Possession outside the U.S. Patent & Trademark Office is restricted to authorized employees and contractors only.			

Form PTO-436A (Rev. 8/92)

Tokyo Electron Limited  
**EXHIBIT 1015**  
 IPR Petition for  
 U.S. Patent No. RE40,264

(FACE)

08/567224

PATENT APPLICATION



08567224

APPROVED FOR LICENSE

INITIALS

JAN 3 1984

Date Entered or Counted

CONTENTS

Date Received or Mailed

1041557

	1. Application _____ papers.	
2.	Pure Fee & Dec	
3.	Dec Fee	4/4/96
4.	Power to Inspect	11-8-96
5.	Petition R.182	11-26-96
6.	Petition granted 1.82	9-16-97
7.	Restriction 30 days	12/10/97 12/10/97
8.	Notice of Abandonment	7/20/98 7/11/98
9.	Request For Access	12-6-98
10.	Request for Access	2-20-01
11.	WD Atty Granted 8/13/01	4-9-01
12.	Request for Access	2-13-08
13.	Request for Access	04/01/11
14.	Request for Access	4-2-14
15.	Request for Access	10/17/14
16.	Request for Access	10/23/14
17.	Request for Access	3-11-15
18.	Request for Access	3-17-15
19.	Request for Access	3-26-15
20.	Request for Access	4-2-15
21.		
22.		
23.		
24.		
25.		
26.		
27.		
28.		
29.		
30.		
31.		
32.		

(FRONT)

Staple Issue Slip Here

POSITION	ID NO.	DATE
CLASSIFIER	10	1/30/96
EXAMINER	253	2/3/96
TYPIST	253	6/22/96
VERIFIER	299	
CORPS CORR.		
SPEC. HAND	428	4/28/96
FILE MAINT.	324	1/30/96
DRAFTING		

INDEX OF CLAIMS

Claim	Date
1	11/29/95
2	
3	
4	
5	
6	
7	
8	
9	
10	
11	
12	
13	
14	
15	
16	
17	
18	
19	
20	
21	
22	
23	
24	
25	
26	
27	
28	
29	
30	
31	
32	
33	
34	
35	
36	
37	
38	
39	
40	
41	
42	
43	
44	
45	
46	
47	
48	
49	
50	

Claim	Date
51	
52	
53	
54	
55	
56	
57	
58	
59	
60	
61	
62	
63	
64	
65	
66	
67	
68	
69	
70	
71	
72	
73	
74	
75	
76	
77	
78	
79	
80	
81	
82	
83	
84	
85	
86	
87	
88	
89	
90	
91	
92	
93	
94	
95	
96	
97	
98	
99	
100	

SYMBOLS

- ✓ ..... Rejected
- = ..... Allowed
- (Through numeral) ..... Canceled
- + ..... Restricted
- N ..... Non-elected
- I ..... Interference
- A ..... Appeal
- O ..... Objected

(LEFT INSIDE)



<b>SEARCHED</b>			
Class	Sub.	Date	Exmr.

*MMS*

<b>SEARCH NOTES</b>		
	Date	Exmr.

<b>INTERFERENCE SEARCHED</b>			
Class	Sub.	Date	Exmr.

(RIGHT OUTSIDE)

PATENT APPLICATION SERIAL NO. **08/567224**

U.S. DEPARTMENT OF COMMERCE  
PATENT AND TRADEMARK OFFICE  
FEE RECORD SHEET

PTO-1556  
(5/87)

BAR CODE LABEL		U.S. PATENT APPLICATION			
					
SERIAL NUMBER	FILING DATE	CLASS	GROUP ART UNIT		
08/567,224	12/04/95	427	1112		
APPLICANT	DANIEL L. FLAMM, WALNUT CREEK, CA; GEORGY VINOGRADOV, YAMANASHI, JAPAN; SHIMAO YONEYAMA, YAMANASHI, JAPAN.				
	**CONTINUING DATA***** VERIFIED				
	**FOREIGN/PCT APPLICATIONS***** VERIFIED				
	FOREIGN FILING LICENSE GRANTED 06/22/96				
STATE OR COUNTRY	SHEETS DRAWING	TOTAL CLAIMS	INDEPENDENT CLAIMS	FILING FEE RECEIVED	ATTORNEY DOCKET NO.
CA	13	20	3	\$880.00	16655-000300
ADDRESS	RICHARD T OGAWA TOWNSEND & TOWNSEND & CREW TWO EMBARCADERO CENTER 8TH FLOOR SAN FRANCISCO CA 94111				
TITLE	PROCESS DEPENDING ON PLASMA DISCHARGES SUSTAINED BY INDUCTIVE COUPLING				
This is to certify that annexed hereto is a true copy from the records of the United States Patent and Trademark Office of the application which is identified above.					
By authority of the COMMISSIONER OF PATENTS AND TRADEMARKS					
Date	Certifying Officer				

00/567224

TOWNSEND and TOMASETTI and CREW  
Stuart Street Tower  
One Market Plaza  
San Francisco, CA 94105  
(415) 326-2400



Atty. Docket No. 16655-000300

"Express Mail" Label No. EM232444814US

Date of Deposit December 4, 1995

PATENT APPLICATION  
COMMISSIONER OF PATENT AND TRADEMARKS  
Washington, D. C. 20231

I hereby certify that this is being deposited with the United States Postal Service "Express Mail Post Office to Addressee" service under 37 CFR 1.10 on the date indicated above and is addressed to the Commissioner of Patents and Trademarks, Washington, D. C. 20231

By *Daniel L. Flamm*

Sir:

- Transmitted herewith for filing is the
  - patent application of
  - design patent application of
  - continuation-in-part patent application of

Inventor(s): Daniel L. Flamm, Georgy Vinogradov, Shimao Yoneyama

For: PROCESS DEPENDING ON PLASMA DISCHARGES SUSTAINED BY INDUCTIVE COUPLING

This application claims priority from each of the following Application Nos./filing dates: \_\_\_\_\_

Enclosed are:

- Patent Application (including 36 pages specification, 3 pages claims, 1 page abstract).
- 13 sheet(s) of  formal  informal drawing(s).
- An assignment of the invention to \_\_\_\_\_
- A  signed  unsigned Declaration & Power of Attorney.
- A  signed  unsigned Declaration.
- A Power of Attorney.
- A verified statement to establish small entity status under 37 CFR 1.9 and 37 CFR 1.27  is enclosed  was filed in the earliest of the above-identified patent application(s).
- A certified copy of a \_\_\_\_\_ application.
- Information Disclosure Statement under 37 CFR 1.97.
- Postcard.

In view of the Unsigned Declaration as filed with this application and pursuant to 37 CFR §1.53(d), Applicant requests deferral of the filing fee until submission of the Missing Parts of Application.

DO NOT CHARGE THE FILING FEE AT THIS TIME.

Telephone:  
(415) 326-2400  
rto/work11665513-app.trn

*Richard T. Ogawa*  
Richard T. Ogawa  
Reg. No.: 37,692  
Attorneys for Applicants





08/567224

TOWNSEND and TOWNSEND and CREW  
Stewart Street Tower  
One Market Plaza  
San Francisco, CA 94105  
(415) 326-2400



Atty. Docket No. 16655-000300  
"Express Mail" Label No. EM232444814US  
Date of Deposit December 4, 1995

**PATENT APPLICATION  
COMMISSIONER OF PATENT AND TRADEMARKS  
Washington, D. C. 20231**

I hereby certify that this is being deposited with the United States Postal Service "Express Mail Post Office to Addressee" service under 37 CFR 1.10 on the date indicated above and is addressed to the Commissioner of Patents and Trademarks, Washington, D. C. 20231

Sir:  
Transmitted herewith for filing is the  
 patent application of  
 design patent application of  
 continuation-in-part patent application of

By James J. Flamm

Inventor(s): Daniel L. Flamm, Georgy Vinogradov, Shimaoy Yoneyama

For: PROCESS DEPENDING ON PLASMA DISCHARGES SUSTAINED BY INDUCTIVE COUPLING

This application claims priority from each of the following Application Nos./filing dates:  
\_\_\_\_\_/\_\_\_\_\_/\_\_\_\_\_/\_\_\_\_\_/\_\_\_\_\_/\_\_\_\_\_

- Enclosed are:
- Patent Application (including 36 pages specification, 3 pages claims, 1 page abstract).
  - 13 sheet(s) of  formal  informal drawing(s).
  - An assignment of the invention to \_\_\_\_\_
  - A  signed  unsigned Declaration & Power of Attorney.
  - A  signed  unsigned Declaration.
  - A Power of Attorney.
  - A verified statement to establish small entity status under 37 CFR 1.9 and 37 CFR 1.27  is enclosed  was filed in the earliest of the above-identified patent application(s).
  - A certified copy of a \_\_\_\_\_ application.
  - Information Disclosure Statement under 37 CFR 1.97.
  - Postcard.

In view of the Unsigned Declaration as filed with this application and pursuant to 37 CFR §1.53(d), Applicant requests deferral of the filing fee until submission of the Missing Parts of Application.

DO NOT CHARGE THE FILING FEE AT THIS TIME.

Telephone:  
(415) 326-2400  
no/work/16655/3-app.tn

Richard T. Ogawa  
Richard T. Ogawa  
Reg. No.: 37,692  
Attorneys for Applicants



16655-003000

## PATENT APPLICATION

### PROCESS DEPENDING ON PLASMA DISCHARGES SUSTAINED BY INDUCTIVE COUPLING

Inventors:

Daniel L. Flamm, a citizen of the United States, residing at 476 Green View Drive, Walnut Creek, California 94596;

Georgy Vinogradov, a citizen of Russia, residing at Dragons Mansion Apt. 306, 5860-5 Ryuchi, Futaba-cho, Kitakomagun, Yamanashi, 400-01 Japan; and

Shimao Yoneyama, a citizen of Japan, residing at 5875-4 Ryuchi, Futaba-cho, Kitakomagun, Yamanashi, 400-01 Japan.

Assignee:

MC Electronics Co., Ltd.

Entity Status:

Large

TOWNSEND and TOWNSEND and CREW  
Steuart Street Tower  
One Market  
San Francisco, CA 94105  
(415) 326-2400



08/567224 A- No-Fee

PROCESS DEPENDING ON PLASMA DISCHARGES SUSTAINED  
BY INDUCTIVE COUPLING

BACKGROUND OF THE INVENTION

5 This invention relates generally to plasma processing. More particularly, the invention is for plasma processing of devices using an inductive discharge. This invention is illustrated in an example with regard to plasma etching and resist stripping of semiconductor devices. The invention also is illustrated with regard to chemical vapor deposition (CVD) of semiconductor devices. But it will be recognized that the invention has a wider range of applicability. Merely by way of example, the invention also can be applied in other plasma etching applications, and deposition of materials such as silicon, silicon dioxide, silicon nitride, polysilicon, among others.

15 Plasma processing techniques can occur in a variety of semiconductor manufacturing processes. Examples of plasma processing techniques occur in chemical dry etching (CDE), ion-assisted etching (IAE), and plasma enhanced chemical vapor deposition (PECVD), including remote plasma deposition (RPCVD) and ion-assisted plasma enhanced chemical vapor deposition (IAPECVD). These plasma processing techniques often rely upon radio frequency power (rf) supplied to an inductive coil for providing power to gas phase species in forming a plasma.

25 Plasmas can be used to form neutral species (i.e., uncharged) for purposes of removing or forming films in the manufacture of integrated circuit devices. For instance, chemical dry etching generally depends on gas-surface reactions involving these neutral species without substantial ion bombardment.

30 In other manufacturing processes, ion bombardment to substrate surfaces is often undesirable. This ion bombardment, however, is known to have harmful effects on properties of material layers in devices and excessive ion bombardment flux and energy can lead to intermixing of materials in adjacent device layers, breaking down oxide and "wear out," injecting of contaminative material formed in the processing environment into substrate material layers, harmful changes in substrate morphology (e.g. amorphotization), etc.

5 Ion assisted etching processes, however, rely upon ion bombardment to the substrate surface in defining selected films. But these ion assisted etching processes commonly have a lower selectivity relative to conventional CDE processes. Hence, CDE is often chosen when high selectivity is desired and ion bombardment to substrates are to be avoided.

One commonly used chemical dry etching technique is conventional photoresist stripping, often termed ashing or stripping. Conventional resist stripping relies upon a reaction between a neutral gas phase species and a surface material layer, typically for removal. This reaction generally forms volatile products with the surface material layer for its removal. The neutral gas phase species is formed by a plasma discharge. This plasma discharge can be sustained by a coil (e.g., helical coil, etc.) operating at a selected frequency in a conventional photoresist stripper. An example of the conventional photoresist stripper is a quarter-wave helical resonator stripper, which is described by U.S. Patent No. 4,368,092 in the name of Steinberg *et al.*

15 Referring to the above, an objective in chemical dry etching is to reduce or even eliminate ion bombardment (or ion flux) to surfaces being processed to maintain the desired etching selectivity. In practice, however, it is often difficult to achieve using conventional techniques. These conventional techniques generally attempt to control ion flux by suppressing the amount of charged species in the plasma source reaching the process chamber. A variety of techniques for suppressing these charged species have been proposed.

20 These techniques often rely upon shields, baffles, large separation distances between the plasma source and the chamber, or the like, placed between the plasma source and the process chamber. The conventional techniques generally attempt to directly suppress charge density downstream of the plasma source by interfering with convective and diffusive transport of charged species. They tend to promote recombination of charged species by either increasing the surface area (e.g., baffles, etc.) relative to volume, or increasing flow time, which relates to increasing the distance between the plasma source and the process chamber.

These baffles, however, cause loss of desirable neutral etchant species as well. The baffles, shields, and alike, also are often cumbersome. Baffles, shields, or the large separation distances also cause undesirable recombinative loss of active species and sometimes cause radio frequency power loss and other problems. These baffles and shields also are a potential source of particulate contamination, which is often damaging to integrated circuits.

Baffles, shields, spatial separation, and alike, when used alone also are often insufficient to substantially prevent unwanted parasitic plasma currents. These plasma currents are generated between the wafer and the plasma source, or between the plasma source and walls of the chamber. It is commonly known that when initial charged species levels are present in an electrical field, the charged species are accelerated and dissociative collisions with neutral particles can multiply the concentration of charge to higher levels. If sufficient "seed" levels of charge and rf potentials are present, the parasitic plasma in the vicinity of the process wafer can reach harmful charge density levels. In some cases, these charge densities may be similar to or even greater than plasma density within the source plasma region, thereby causing even more ion flux to the substrate.

Charge densities also create a voltage difference between the plasma source and processing chamber or substrate support, which can have an additional deleterious effect. This voltage difference enhances electric fields that can accelerate extraction of charge from the plasma source. Hence, their presence often induces increased levels of charge to be irregularly transported from the plasma source to process substrates, thereby causing non-uniform ion assisted etching.

Conventional ion assisted plasma etching, however, often requires control and maintenance of ion flux intensity and uniformity within selected process limits and within selected process energy ranges. Control and maintenance of ion flux intensity and uniformity are often difficult to achieve using conventional techniques. For instance, capacitive coupling between high voltage selections of the coil and the plasma discharge often cause high and uncontrollable plasma potentials relative to ground. It is generally understood that voltage difference

5 between the plasma and ground can cause damaging high energy ion bombardment of articles being processed by the plasma, as illustrated by U.S. Patent No. 5,234,529 in the name of Johnson. It is further often understood that rf component of the plasma potential varies in time since it is derived from a coupling to time varying rf excitation. Hence, the energy of charged particles from plasma in conventional inductive sources is spread over a relatively wide range of energies, which undesirably tends to introduce uncontrolled variations in the processing of articles by the plasma.

10 The voltage difference between the region just outside of a plasma source and the processing chamber can be modified by introducing internal conductive shields or electrode elements into the processing apparatus downstream of the source. When the plasma potential is elevated with respect to these shield electrodes, however, there is a tendency to generate an undesirable capacitive discharge between the shield and plasma source. These electrode elements are often a source of contamination and the likelihood for contamination is even greater when there is capacitive discharge (ion bombardment from capacitive discharge is a potential source of sputtered material). Contamination is damaging to the manufacture of integrated circuit devices.

20 Another limitation is that the shield or electrode elements generally require small holes therein as structural elements. These small holes are designed to allow gas to flow therethrough. The small holes, however, tend to introduce unwanted pressure drops and neutral species recombination. If the holes are made larger, the plasma from the source tends to survive transport through the holes and unwanted downstream charge flux will often result. In addition, undesirable discharges to these holes in shields can, at times, produce an even more undesirable hollow cathode effect.

25 In conventional helical resonator designs, conductive external shields are interposed between the inductive power (e.g., coil, etc.) and walls of the vacuum vessel containing the plasma. A variety of limitations with these external capacitive shielded plasma designs (e.g., helical resonator, inductive discharge, etc.) have been observed. In particular, the capacitively shielded design often

30

produces plasmas that are difficult to tune and even ignite. Alternatively, the use of unshielded plasma sources (e.g., conventional quarter-wave resonator, conventional half-wave resonator, etc.) attain a substantial plasma potential from capacitive coupling to the coil, and hence are prone to create uncontrolled parasitic plasma currents to grounded surfaces. Accordingly, the use of either the shielded or the unshielded sources using conventional quarter and half-wave rf frequencies produce undesirable results.

In many conventional plasma sources a means of cooling is required to maintain the plasma source and substrates being treated below a maximum temperature limit. Power dissipation in the structure causes heating and thereby increases the difficulty and expense of implementing effective cooling means. Inductive currents may also be coupled from the excitation coil into internal or capacitive shields and these currents are an additional source of undesirable power loss and heating. Conventional capacitive shielding in helical resonator discharges utilized a shield which was substantially split along the long axis of the resonator to lessen eddy current loss. However, such a shield substantially perturbs the resonator characteristics owing to unwanted capacitive coupling and current which flows from the coil to the shield. Since there are no general design equations, nor are properties currently known for resonators which are "loaded" with a shield along the axis, sources using this design must be sized and made to work by trial and error.

In inductive discharges, it is highly desirable to be able to substantially control the plasma potential relative to ground potential, independent of input power, pressure, gas composition and other variables. In many cases, it is desired to have the plasma potential be substantially at ground potential (at least offset from ground potential by an amount insignificantly different from the floating potential or intrinsic DC plasma potential). For example, when a plasma source is utilized to generate neutral species to be transported downstream of the source for use in ashing resist on a semiconductor device substrate (a wafer or flat panel electronic display), the concentration and potential of charged plasma species in the reaction zone are desirably reduced to avoid charging damage from electron

or ionic current from the plasma to the device. When there is a substantial potential difference between plasma in the source and grounded surfaces beyond the source, there is a tendency for unwanted parasitic plasma discharges to form outside of the source region.

5                   Another undesirable effect of potential difference is the acceleration  
of ions toward grounded surfaces and subsequent impact of the energetic ions with  
surfaces. High energy ion bombardment may cause lattice damage to the device  
substrate being processed and may cause the chamber wall or other chamber  
10 materials to sputter and contaminate device wafers. In other plasma processing  
procedures, however, some ion bombardment may be necessary or desirable, as is  
the case particularly for anisotropic ion-induced plasma etching procedures (for a  
discussion of ion-enhanced plasma etching mechanisms See Flamm (Ch. 2, pp.94-  
183 in Plasma Etching, An Introduction, D. M. Manos and D.L. Flamm, eds.,  
Academic Press, 1989)). Consequently, uncontrolled potential differences, such as  
15 that caused by "stray" capacitive coupling from the coil of an inductive plasma  
source to the plasma, are undesirable.

Referring to the above limitations, conventional plasma sources also  
have disadvantages when used in conventional plasma enhanced CVD techniques.  
These techniques commonly form a reaction of a gas composition in a plasma  
20 discharge. One conventional plasma enhanced technique relies upon ions aiding in  
rearranging and stabilizing the film, provided the bombardment from the plasma is  
not sufficiently energetic to damage the underlying substrate or the growing film.  
Conventional resonators and other types of inductive discharges often produce  
parasitic plasma currents from capacitive coupling, which often detrimentally  
25 influences film quality, e.g., an inferior film, etc. These parasitic plasma currents  
are often uncontrollable, and highly undesirable. These plasma sources also have  
disadvantages in other plasma processing techniques such as ion-assisted etching,  
and others. Of course, the particular disadvantage will often depend upon the  
application.

30                   To clarify certain concepts used in this application, it will be  
convenient to introduce these definitions.



5

10

15

20

25

Ground (or ground potential): These terms are defined as a reference potential which is generally taken as the potential of a highly conductive shield or other highly conductive surface which surrounds the plasma source. To be a true ground shield in the sense of this definition, the RF conductance at the operating frequency is often substantially high so that potential differences generated by current within the shield are of negligible magnitude compared to potentials intentionally applied to the various structures and elements of the plasma source or substrate support assembly. However, some realizations of plasma sources do not incorporate a shield or surface with adequate electrical susceptance to meet this definition. In implementations where there is a surrounding conductive surface that is somewhat similar to a ground shield or ground plane, the ground potential is taken to be the fictitious potential which the imperfect grounded surface would have equilibrated to if it had zero high frequency impedance. In designs where there is no physical surface which is adequately configured or which does not have insufficient susceptance to act as a "ground" according to the above definition, ground potential is the potential of a fictitious surface which is equi-potential with the shield or "ground" conductor of an unbalanced transmission line connection to the plasma source at its RF feed point. In designs where the plasma source is connected to an RF generator with a balanced transmission line RF feed, "ground" potential is the average of the driven feed line potentials at the point where the feed lines are coupled to the plasma source.

30

35

Inductively Coupled Power: This term is defined as power transferred to the plasma substantially by means of a time-varying magnetic flux which is induced within the volume containing the plasma source. A time-varying magnetic flux induces an electromotive force in accord with Maxwell's equations. This electromotive force induces motion by electrons and other charged particles in the plasma and thereby imparts energy to these particles.

40

RF inductive power source and bias power supply: In most conventional inductive plasma source reactors, power is supplied to an inductive coupling element (the inductive coupling element is often a multi-turn coil which abuts a dielectric wall containing a gas where the plasma is ignited at low pressure) by an rf power generator.

45

Conventional Helical Resonator: Conventional helical resonator can be defined as plasma applicators. These plasma applicators have been designed and operated in multiple configurations, which were described in, for example, U.S. Patent No. 4,918,031 in the names

of Flamm *et al.*, U.S. Patent No. 4,368,092 in the name of Steinberg *et al.*, U.S. Patent No. 5,304,282 in the name of Flamm, U.S. Patent No. 5,234,529 in the name of Johnson, U.S. Patent No. 5,431,968 in the name of Miller, and others. In these configurations, one end of the helical resonator applicator coil has been grounded to its outer shield. In one conventional configuration, a quarter wavelength helical resonator section is employed with one end of the applicator coil grounded and the other end floating (i.e., open circuited). A trimming capacitance is sometimes connected between the grounded outer shield and the coil to "fine tune" the quarter wave structure to a desired resonant frequency that is below the native resonant frequency without added capacitance. In another conventional configuration, a half-wavelength helical resonator section was employed in which both ends of the coil were grounded. The function of grounding the one or both ends of the coil was believed to be not essential, but advantageous to "stabilize the plasma operating characteristics" and "reduce the possibility of coupling stray current to nearby objects." See U.S. Patent No. 4,918,031.

Conventional resonators have also been constructed in other geometrical configurations. For instance, the design of helical resonators with a shield of square cross section is described in Zverev *et al.*, IRE Transactions on Component Parts, pp. 99-110, Sept. 1961. Johnson (U.S. Patent No. 5,234,529) teaches that one end of the cylindrical spiral coil in a conventional helical resonator may be deformed into a planar spiral above the top surface of the plasma reactor tube. U.S. Patent No. 5,241,245 in the names of Barnes *et al.* teach the use of conventional helical resonators in which the spiral cylindrical coil is entirely deformed into a planar spiral arrangement with no helical coil component along the sidewalls of the plasma source (this geometry has often been referred to as a "transformer coupled plasma," termed a TCP).

From the above it is seen that an improved technique, including a method and apparatus, for plasma processing is often desired.

#### SUMMARY OF THE INVENTION

The present invention provides a technique, including a method and apparatus, for fabricating a product using a plasma discharge. The present technique relies upon the control of the instantaneous plasma AC potential to selectively control a variety of plasma characteristics. These characteristics

include the amount of neutral species, the amount of charged species, overall plasma potential, the spatial extent and distribution of plasma density, the distribution of electrical current, and others. This technique can be used in applications including chemical dry etching (e.g., stripping, etc.), ion-enhanced etching, plasma immersion ion implantation, chemical vapor deposition and material growth, and others.

In one aspect of the invention, a process for fabricating a product is provided. These products include a varieties of devices (e.g., semiconductor, flat panel displays, micro-machined structures, etc.) and materials, e.g., diamonds, raw materials, plastics, etc. The process includes steps of subjecting a substrate to a composition of entities. At least one of the entities emanates from a species generated by a gaseous discharge excited by a high frequency field in which the vector sum of phase and anti-phase capacitive coupled voltages (e.g., AC plasma voltage) from the inductive coupling structure substantially balances. This process provides for a technique that is substantially free from stray or parasitic capacitive coupling from the plasma source to chamber bodies (e.g., substrate, walls, etc.) at or near ground potential.

In another aspect of the invention, another process for fabricating a product is provided. The process includes steps of subjecting a substrate to a composition of entities. At least one of the entities emanates from a species generated by a gaseous discharge excited by a high frequency field in which the vector sum of phase and anti-phase capacitive coupled voltages from the inductive coupling structure is selectively maintained. This process provides for a technique that can selectively control the amount of capacitive coupling to chamber bodies at or near ground potential.

A further aspect of the invention provides yet another process for fabricating a product. This process includes steps of subjecting a substrate to a composition of entities. At least one of the entities emanates from a species generated by a gaseous discharge excited by a high frequency field in which the vector sum of phase and anti-phase capacitive coupled voltages from the inductive coupling structure is selectively maintained. A further step of selectively applying

a voltage between the at least one of the entities in the plasma source and a substrate is provided. This process provides for a technique that can selectively control the amount of capacitive coupling to chamber bodies at or near ground potential, and provide for a driving voltage between the entities and a substrate.

5           Another aspect of the invention provides another process for fabricating a product. The process comprises steps of subjecting a substrate to a composition of entities and using the resulting substrate for completion of the product. At least one of the entities emanates from a species generated by a gaseous discharge provided by a plasma applicator, e.g., a helical resonator,  
10           inductive coil, transmission line, etc. This plasma applicator has an integral current driven by capacitive coupling of a plasma column to elements with a selected potential greater than a surrounding shield potential substantially equal to capacitive coupling of the plasma column to substantially equal elements with a potential below shield potential.

15           In a further aspect, the invention provides an apparatus for fabricating a product. The apparatus has an enclosure comprising an outer surface and an inner surface. The enclosure houses a gaseous discharge. The apparatus also includes a plasma applicator (e.g., helical coil, inductive coil, transmission line, etc.) disposed adjacent to the outer surface. A high frequency power source  
20           operably coupled to the plasma applicator is included. The high frequency power source provides high frequency to excite the gaseous discharge to provide at least one entity from a high frequency field in which the vector sum of phase and anti-phase capacitive current coupled from the inductive coupling structure is selectively maintained.

25           In another aspect, the present invention provides an improved plasma discharge apparatus. This plasma discharge apparatus includes a plasma source, a plasma applicator (e.g., inductive coil, transmission line, etc.), and other elements. This plasma applicator provides a de-coupled plasma source. A wave adjustment circuit (e.g., RLC circuit, coil, transmission line, etc.) is operably  
30           coupled to the plasma applicator. The wave adjustment circuit can selectively adjust phase and anti-phase potentials of the plasma from an rf power supply. This

rf power supply is operably coupled to the wave adjustment circuit.

The present invention achieves these benefits in the context of known process technology. However, a further understanding of the nature and advantages of the present invention may be realized by reference to the latter portions of the specification and attached drawings.

#### BRIEF DESCRIPTION OF THE DRAWINGS

Fig. 1 is a simplified diagram of a plasma etching apparatus according to the present invention;

Figs. 2A-2E are simplified configurations using wave adjustment circuits according to the present invention;

Fig. 3 is a simplified diagram of a chemical vapor deposition apparatus according to the present invention;

Fig. 4 is a simplified diagram of a stripper according to the present invention;

Figs. 5A-5C are more detailed simplified diagrams of a helical resonator according to the present invention;

Fig. 6 is a conventional quarter-wave helical resonator plasma etching apparatus with stray plasma which results from the coupling in the conventional design;

Fig. 7 is a simplified diagram of the rf voltage distribution along the coil of the Fig. 6 apparatus;

Fig. 8 is a simplified top-view diagram of a stripping apparatus according to the present experiments; and

Fig. 9 is a simplified side-view diagram of a stripping apparatus according to the present experiments.

#### DETAILED DESCRIPTION OF THE INVENTION

Fig. 1 is a simplified diagram of a plasma etch apparatus according to the present invention. This etch apparatus is provided with an inductive applicator, e.g., inductive coil. This etch apparatus depicted, however,

is merely an illustration, and should not limit the scope of the claims as defined herein. One of ordinary skilled in the art may implement the present invention with other treatment chambers and the like.

5 The etch apparatus includes a chamber 12, a feed source 14, an exhaust 16, a pedestal 18, an inductive applicator 20, a radio frequency (rf) power source 22 to the inductive applicator 20, wave adjustment circuits 24, 29 (WACs), a radio frequency power source 35 to the pedestal 18, a controller 36, and other elements. Optionally, the etch apparatus includes a gas distributor 17.

10 The chamber 12 can be any suitable chamber capable of housing a product 28, such as a wafer to be etched, and for providing a plasma discharge therein. The chamber can be a domed chamber for providing a uniform plasma distribution over the product 28 to be etched, but the chamber also can be configured in other shapes or geometries, e.g., flat ceiling, truncated pyramid, cylindrical, rectangular, etc. Depending upon the application, the chamber is  
15 selected to produce a uniform entity density over the pedestal 18, providing a high density of entities (i.e., etchant species) for etching uniformity.

The present chamber includes a dome 25 having an interior surface 26 made of quartz or other suitable materials. The exterior surface of the chamber is typically a dielectric material such as a ceramic or the like. Chamber 12 also  
20 includes a process kit with a focus ring 32, a cover (not shown), and other elements. Preferably, the plasma discharge is derived from the inductively coupled plasma source that is a de-coupled plasma source (DPS) or a helical resonator, although other sources can be employed.

25 The de-coupled source originates from rf power derived from the inductive applicator 20. Inductively coupled power is derived from the power source 22. The rf signal frequencies ranging from 800 kHz to 80 MHz can be provided to the inductive applicator 20. Preferably, the rf signal frequencies range from 5 MHz to 60 MHz. The inductive applicator (e.g., coil, antenna, transmission line, etc.) overlying the chamber ceiling can be made using a variety  
30 of shapes and ranges of shapes. For example, the inductive applicator can be a single integral conductive film, a transmission line, or multiple coil windings. The

shape of the inductive applicator and its location relative to the chamber are selected to provide a plasma overlying the pedestal to improve etch uniformity.

5 The plasma discharge (or plasma source) is derived from the inductive applicator 20 operating at selected phase 23 and anti-phase 27 potentials (i.e., voltages) that substantially cancel each other. The controller 36 is operably coupled to the wave adjustment circuits 24, 29. In one embodiment, wave adjustment circuits 24, 29 provide an inductive applicator operating at full-wave multiples 21. This embodiment of full-wave multiple operation provides for balanced capacitance of phase 23 and anti-phase voltages 27 along the inductive applicator (or coil adjacent to the plasma). This full-wave multiple operation reduces or substantially eliminates the amount of capacitively coupled power from the plasma source to chamber bodies (e.g., pedestal, walls, wafer, etc.) at or close to ground potential. Alternatively, the wave adjustment circuits 24, 29 provide an inductive applicator that is effectively made shorter or longer than a full-wave length multiple by a selected amount, thereby operating at selected phase and anti-phase voltages that are not full-wave multiples. Alternatively, more than two, one or even no wave adjustment circuits can be provided in other embodiments. But in all of these above embodiments, the phase and anti-phase potentials substantially cancel each other, thereby providing substantially no capacitively coupled power from the plasma source to the chamber bodies.

10 In alternative embodiments, the wave adjustment circuit can be configured to provide selected phase and anti-phase coupled voltages coupled from the inductive applicator to the plasma that do not cancel. This provides a controlled potential between the plasma and the chamber bodies, e.g., the substrate, grounded surfaces, walls, etc. In one embodiment, the wave adjustment circuits can be used to selectively reduce current (i.e., capacitively coupled current) to the plasma. This can occur when certain high potential difference regions of the inductive applicator to the plasma are positioned (or kept) away from the plasma region (or inductor-containing-the-plasma region) by making them go into the wafer adjustment circuit assemblies, which are typically configured outside of the plasma region. In this embodiment, capacitive current is reduced

and a selected degree of symmetry between the phase and anti-phase of the coupled voltages is maintained, thereby providing a selected potential or even substantially ground potential. In other embodiments, the wave adjustment circuits can be used to selectively increase current (i.e., capacitively coupled current) to the plasma.

5 As shown, the wave adjustment circuits are attached (e.g., connected, coupled, etc.) to ends of the inductive applicator. Alternatively, each of these wave adjustment circuits can be attached at an intermediate position away from the inductive application ends. Accordingly, upper and lower tap positions for respective wave adjustment circuits can be adjustable. But both the inductive  
10 applicator portions below and above each tap position are active. That is, they both can interact with the plasma discharge.

A sensing apparatus can be used to sense plasma voltage and use automatic tuning of the wave adjustment circuits and any rf matching circuit between the rf generator and the plasma treatment chamber. This sensing  
15 apparatus can maintain the average AC potential at zero or a selected value relative to ground or any other reference value. This wave adjustment circuit provides for a selected potential difference between the plasma source and chamber bodies. These chamber bodies may be at a ground potential or a potential supplied by another bias supply, e.g., See Fig. 1 reference numeral 35. Examples of wave  
20 adjustment circuits are described by way of the Figs. below.

For instance, Figs. 2A to 2E are simplified configurations using the wave adjustment circuits according to the present invention. These simplified configurations should not limit the scope of the claims herein. In an embodiment, these wave adjustment circuits employ substantially equal circuit elements (e.g.,  
25 inductors, capacitors, transmission line sections, and others) such that the electrical length of the wave adjustment circuits in series with the inductive applicator coupling power to the plasma is substantially an integral multiple of one wavelength. In other embodiments, the circuit elements provide for inductive applicators at other wavelength multiples, e.g., one-sixteenth-wave, one-eighth-wave, quarter-wave, half-wave, three-quarter wave, etc. In these embodiments  
30 (e.g., full-wave multiple, half-wave, quarter-wave, etc.), the phase and anti-phase



relationship between the plasma potentials substantially cancel each other. In further embodiments, the wave adjustment circuits employ circuit elements that provide plasma applicators with phase and anti-phase potential relationships that do not cancel each other out using a variety of wave length portions.

5 Fig. 2A is a simplified illustration of an embodiment 50 using wave adjustment circuits according to the present invention. This embodiment 50 includes a discharge tube 52, an inductive applicator 55, an exterior shield 54, an upper wave adjustment circuit 57, a lower wave adjustment circuit 59, an rf power supply 61, and other elements. The upper wave adjustment circuit 57 is a helical coil transmission line portion 69, outside of the plasma source region 60. Lower 10 wave adjustment circuit 59 also is a helical coil transmission line portion 67 outside of the plasma source region 60. The power supply 61 is attached 65 to this lower helical coil portion 67, and is grounded 63. Each of the wave adjustment circuits also are shielded 66, 68.

15 In this embodiment, the wave adjustment circuits are adjusted to provide substantially zero AC voltage at one point on the inductive coil (refer to point 00 in Fig. 2A). This embodiment also provides substantially equal phase 70 and anti-phase 71 voltage distributions in directions about this point (refer to 00-A and 00-C in Fig. 2A) and provides substantially equal capacitance coupling to the plasma from physical inductor elements (00-C) and (00-A), carrying the phase and 20 anti-phase potentials. Voltage distributions 00-A and 00-C are combined with C-D and A-B (shown by the phantom lines) would substantially comprise a full-wave voltage distribution in this embodiment where the desired configuration is a selected phase/antiphase portion of a full-wave inductor (or helical resonator) 25 surrounding the plasma source discharge tube.

In this embodiment, it is desirable to reduce or minimize capacitive coupling current from the inductive element to the plasma discharge in the plasma source. Since the capacitive current increases monotonically with the magnitude of the difference of peak phase and anti-phase voltages, which occur at points A and C in Fig. 2A, this coupling can be lessened by reducing this voltage difference. In 30 Fig. 2A, for example, it is achieved by way of two wave adjustment circuits 57,

59. Coil 55 (or discharge source) is a helical resonator and the wave adjustment circuits 57, 59 are helical resonators.

5 The discharge source helical resonator 53 can be constructed using conventional design formulae. Generally, this helical resonator includes an electrical length which is a selected phase portion "x" (A to 00 to C) of a full-wave helical resonator. The helical resonator wave adjustment circuits are each selected to comprise a portion ( $2\pi-x$ ) of full-wave helical resonators. Physical parameters for the wave adjustment helical resonators can be selected to realize practical physical dimensions and appropriate Q,  $Z_0$ , etc values. In particular, 10 some or even all of the transmission line parameters (Q,  $Z_0$ , etc.) of the wave adjustment circuit sections may be selected to be substantially the same as the transmission line parameters of the inductive applicator. The portion of the inductive plasma applicator helical resonator, on the other hand, is designed and sized to provide selected uniformity values over substrate dimensions within an 15 economical equipment size and reduced Q.

The wave adjustment circuit provides for external rf power coupling, which can be used to control and match power to the plasma source, as compared to conventional techniques used in helical resonators and the like. In particular, conventional techniques often match to, couple power to, or match to 20 the impedance of the power supply to the helical resonator by varying a tap position along the coil above the grounded position, or selecting a fixed tap position relative to a grounded coil end and matching to the impedance at this position using a conventional matching network, e.g., LC network,  $\pi$  network, etc. Varying this tap position along the coil within a plasma source is often 25 cumbersome and generally imposes a difficult mechanical design problems. Using the fixed tap and external matching network also is cumbersome and can cause unanticipated changes in the discharge Q, and therefore influences its operating mode and stability. In the present embodiments, the wave adjustment circuits can be positioned outside of the plasma source (or constrained in space containing the inductive coil, e.g., See Fig. 2A. Accordingly, the mechanical design (e.g., 30 means for varying tap position, change in the effective rf power coupling point by

electrical means, etc.) of the tap position are simplified relative to those conventional techniques.

In the present embodiment, rf power is fed into the lower wave adjustment circuit 59. Alternatively, rf power can be fed into the upper wave adjustment circuit (not shown). The rf power also can be coupled directly into the inductive plasma coupling applicator (e.g., coil, etc.) in the wave adjustment circuit design, as illustrated by Fig. 2B. Alternatively, other application will use a single wave adjustment circuit, as illustrated by Fig. 2C. Power can be coupled into this wave adjustment circuit or by conventional techniques such as a tap in the coil phase. In some embodiments, this tap in the coil phase is positioned above the grounded end. An external impedance matching network may then be operably coupled to the power for satisfactory power transfer efficiency from, for example, a conventional coaxial cable to impedances (current to voltage ratios) existing between the wave adjustment circuit terminated end of the applicator.

A further embodiment using multiple inductive plasma applicators also is provided, as shown in Fig. 2D. This embodiment includes multiple plasma applicators (PA1, PA2...PAN). These plasma applicators respectively provide selected combinations of inductively coupled power and capacitively coupled power from respective voltage potentials (V1, V2...Vn). Each of these plasma applicators derives power from its power source (PS1, PS2...PSn) either directly through an appropriate matching or coupling network or by coupling to a wave adjustment circuit as described. Alternatively, a single power supply using power splitters and impedance matching networks can be coupled to each (or more than two) of the plasma applicators. Alternatively, more than one power supply can be used where at least one power supply is shared among more than one plasma applicator. Each power source is coupled to its respective wave adjustment circuits (WAC1, WAC2...WACn).

Generally, each plasma applicator has an upper wave adjustment circuit (e.g., WAC 1a, WAC 2a...WACna) and a lower wave adjustment circuit (e.g., WAC1b, WAC 2b...WACnb). The combination of upper and lower wave adjustment circuits are used to adjust the plasma source potential for each plasma

source zone. Alternatively, a single wave adjustment circuit can be used for each plasma applicator. Each wave adjustment circuit can provide substantially the same impedance characteristics, or substantially distinct impedance characteristics. Of course, the particular configuration used will depend upon the application.

5 For instance, multiple plasma applicators can be used to employ distinct excitation frequencies for selected zones in a variety of applications. These applications include film deposition using plasma enhanced chemical deposition, etching by way of ion enhanced etching or chemical dry etching and others. Plasma cleaning also can be performed by way of the multiple plasma  
10 applicators. Specifically, at least one of the plasma applicators will define a cleaning plasma used for cleaning purposes. In one embodiment, this cleaning plasma can have an oxygen containing species. This cleaning plasma is defined by using an oxygen discharge, which is sustained by microwave power to a cavity or resonant microwave chamber abutting or surrounding a conventional dielectric  
15 vessel. Of course, a variety of other processes also can be performed by way of this multiple plasma applicator embodiment.

This present application using multiple plasma applicators can provide a multi-zone (or multi-chamber) plasma source without the use of conventional mechanical separation means (e.g., baffles, separate process  
20 chambers, etc.). Alternatively, the degree of interaction between adjacent zones or chambers can be relaxed owing to the use of voltage potential control via wave adjustment circuits. This plasma source provides for multiple plasma source chambers, each with its own control via its own plasma applicator. Accordingly, each plasma applicator provides a physical zone region (i.e., plasma source) with  
25 selected plasma characteristics (e.g., capacitively coupled current, inductively coupled current, etc.). These zones can be used alone or can be combined with other zones. Of course, the particular configuration will depend upon the application.

In the present embodiments, the wave adjustment circuit can be  
30 made from any suitable combination of element(s) such as various types of transmission lines, circuits, etc. These transmission lines include conventional

5 solid or air dielectric coaxial cable, or ordinary, repeating inductor/capacitor discrete approximations to transmission lines, and others. These types of transmission lines are co-axial transmission lines, balanced parallel transmission lines, so called slow wave transmission lines with a spiral inner conductor (e.g., selected portions of a helical resonator, etc.), and others. Individual lumped, fixed, or adjustable combinations of resistors, capacitors, and inductors (e.g., matching networks, etc.) also can be used in place of transmission line sections for the wave adjustment circuit. These general types of wave adjustment circuits are frequency dependent, and can be termed frequency dependent wave adjustment circuits (or FDWACs).

10 Frequency independent elements also can be used as the wave adjustment circuits. These wave adjustment circuits can be termed frequency independent WACs (or FIWACs). Frequency independent wave adjustment circuits include degenerate cases such as short-circuit connections to ground or an infinite impedance (i.e., open circuit), and others. Frequency independent wave adjustment circuits can be used alone, or in combination with the frequency dependent wave adjustment circuits. Alternatively, the frequency dependent wave adjustment circuits can be used alone or in combination with other wave adjustment circuits. Other variations, alternative constructions, and modifications also may be possible depending upon the application.

15 With regard to operation of the wave adjustment circuits, various embodiments can be used, as illustrated by Fig. 2E. The wave adjustment circuits are used to select a wave length portion to be applied in the plasma applicator. In some embodiments, the average rf plasma potential is maintained close to ground potential by providing substantially equal phase 90, 81 and anti-phase 91, 82 capacitively coupled portions of the inductive applicator. This can occur in multi-wave embodiments 92, full-wave embodiments 93, half-wave multiple embodiments, quarter-wave multiple embodiments, or any other embodiments 94.

20 In alternative embodiments, it is desirable to maintain an elevated source plasma voltage relative to ground potential to induce a controlled ion plasma flux (or ion bombardment) to the product substrate (or any other chamber

bodies). These embodiments are provided by selecting distinct electrical lengths for each of the wave adjustment circuit sections such that the capacitive coupled current from a phase section of the inductive plasma applicator is in excess of capacitive coupled current from its anti-phase portion. In these embodiments, the wave adjustment circuit provides a deliberate imbalance between the phase and anti-phase of the coupled voltages. In some embodiments 97, this occurs by shifting the zero voltage nodes along the process chamber axially, thereby achieving a bias relative to the plasma discharge. As shown, the phase 95 is imbalanced relative to its anti-phase 96. In other embodiments 99, one phase portion 84 is imbalanced by way of a different period relative to its complementary phase portion 85. Other embodiments are provided where the source plasma voltage is lower relative to ground potential. In the embodiments where imbalance is desirable, the potential difference between the phase and anti-phase potential portions is reduced (or minimized) when the amount of sputtering (e.g., wall sputtering, etc.) is reduced. The amount of sputtering, however, can be increased (or maximized) by increasing the potential difference between the phase and anti-phase potential portions. Sputtering is desirable in, for example, sputtering a quartz target, cleaning applications, and others. Of course, the type of operation used will depend upon the application.

Current maxima on an inductive applicator with distributed capacitance (e.g., helical resonator transmission line, etc.) occur at voltage minima. In particular, conventional quarter-wave helical resonator current is substantially at a relative maximum at its grounded end of the coil, and to a lesser extent in the nearby coil elements. Therefore, partial inductive coupling of power, if it occurs, will tend to be at this grounded end. In conventional half-wave helical resonators, inductive coupling tends to occur at each of the two grounded ends.

In the present invention, substantially anti-symmetric phase and anti-phase inductive half-wave and other fractional wave applicator sections support substantially more inductive coupling at a selected rf voltage node, e.g., Fig. 2A reference numeral 00. This effect is caused by high current flow in the inductor

applicator zones (or sections) both directly above and below the node (corresponding to inductor elements in the phase and anti-phase sections at and immediately adjacent to the rf voltage zero point). It should be noted that conventional quarter and half-wave inductively coupled inductive applicators have inductive coupling which abruptly declines below the grounded coil locations because the coil terminates and voltage extrema are present at these locations. This generally produces conventional quarter and half-wave helical resonators that tend to operate in a capacitive mode, or with a substantial fraction of power which is capacitively coupled to the plasma, unless the plasma is shielded from coil voltages, as noted above.

In a specific embodiment, the power system includes selected circuit elements for effective operation. The power system includes an rf power source. This rf power source can be any suitable rf generator capable of providing a selected or continuously variable frequency in a range from about 800 kHz to about 80 MHz. Many generators are useful. Preferably, generators capable of operating into short and open-circuit loads without damage are used for industrial applications. One example of a suitable generator is a fixed frequency rf generator 28.12 MHz - 3 kW CX-3000 power supply made by Comdel, Inc. of Beverly, Massachusetts. A suitable variable frequency power supply arrangement capable of the 3 kW output over an 800 kHz to 50 MHz range can be made by driving an IFI Model TCCX3500 High Power Wide Band Amplifier with a Hewlett Packard HP116A, 0-50 MHz Pulse/Function Generator. Other generators including those capable of higher or lower power also can be used depending upon the application.

Power from the generator can be transmitted to the plasma source by conventional coaxial cable transmission line. An example of this transmission line is RG8/U and other higher temperature rated cable (e.g., RG1151U, etc.) with a coaxial TEFLON™ dielectric. In some embodiments, power is fed to conventional end-grounded half-wave helical resonators by positioning a movable tap on the helical coil and connecting a power source between the tap and the ground. In other embodiments, matching networks can be introduced between the coaxial cable power feed and the helical coil tap for flexibility. The matching

network will depend on the selected wave configuration and wave adjustment circuits. In a balanced half-wave helical resonator embodiment, for example, the ends of the resonator coil can be terminated with wave adjustment circuits which substantially have zero susceptance. In particular, the wave adjustment circuit is designed as an open circuit by making no electrical connections to the ends of the coil, or establishing an electrical equivalence thereof. Alternatively, the ends of the coil are isolated by chokes series resistance, thereby DC coupled to a fixed reference potential. These types of wave adjustment circuits are frequency independent and are "degenerate" cases. In these embodiments, the rf power is provided such that the phase and anti-phase current flows above and below the electrical midpoint of the coil. This provides for substantially balanced phase and anti-phase current flow from the power source stabilizing desired operation in coil voltages above the midpoint of the coil, and also provides substantially equal phase and anti-phase voltages.

The embodiments described above also can be applied to other plasma processing applications, e.g., PECVD, plasma immersion ion implantation (PIII), stripping, sputtering, etc. For instance, Fig. 3 is a simplified CVD apparatus 100 according to the present invention. The present CVD apparatus includes a chamber 112, a feed source 114, an exhaust 116, a pedestal 118, a power source 122, a ground 124, a helical resonator 126, and other elements. The helical resonator 126 has a coil 132, an outer shield 133, and other elements. The chamber can be any suitable chamber capable of housing a product 119 such as a wafer for deposition, and for providing a plasma discharge therein. Preferably, the chamber is a right circular cylinder chamber for providing an uniform plasma species distribution over the product. But the chamber can also be configured in the form of rectangular right cylinder, a truncated cone, and the like. The chamber and fixtures are constructed from aluminum and quartz, and other suitable materials. The plasma discharge is derived from a plasma source which is preferably a helical resonator discharge or other inductive discharge using a wave adjustment circuit or other techniques to selectively adjust phase-anti-phase potentials. The present CVD apparatus provides for deposition of a dielectric



material, e.g., silicon dioxide or the like.

The product 119 having an upper surface 130 is placed into the present CVD apparatus for deposition, e.g., plasma enhanced chemical vapor deposition (PECVD), and others. Examples of deposition materials include a dielectric material such as a silicon dioxide ( $\text{SiO}_2$ ), a phosphosilicate glass (PSG), a borophosphosilicate glass (BPSG), a silicon nitride ( $\text{Si}_3\text{N}_4$ ), among others.

In one embodiment, the deposition occurs by introducing a mixture comprising organic silane, oxygen, and an inert gas such as helium or argon according to the present invention. The organic silane can be any suitable organic silicate material such TEOS, HMDS, OMCTS, and the like. Deposition is also conformal in selected instances. As for the oxygen, it includes a flow rate of about 1 liter/per minute and less. A relative flow rate between the organic silane such as TEOS and oxygen ranges from about 1:40 to about 2:1, and is preferably less than about 1:2 in certain applications. A deposition temperature of the organic silane-oxygen layer ranges from about 300 to about 500°C, and can also be at other temperatures. Pressures in the range of 1 to 7 Torr are generally used. Of course, other concentrations, temperatures, materials, and flow rates can be used depending upon the particular application.

This chamber also includes a wave adjustment circuit 127. The wave adjustment circuit 127 is used to provide a helical coil operating with capacitive coupling to selected phase and anti-phase voltages. This portion 127 of the wave adjustment circuit coil also is shielded 140 to prevent rf from interfering with the plasma discharge or external elements, e.g., equipment, power, etc. The coil shield 140 is made of a conductive material such as copper, aluminum, or the like. In one embodiment, an operating frequency is selected and the wave adjustment circuit is adjusted to short circuit the upper end of the helical applicator coil to ground 124. This provides a helical coil operating at approximately a full-wave multiple and has substantially equal phase and anti-phase sections. This full-wave multiple operation provides for balanced capacitance of phase 151 and anti-phase 153 voltages along the coil 132 adjacent to the plasma source. Full-wave multiple operation reduces or even substantially eliminates the amount of

capacitively coupled power from the plasma source to chamber bodies (e.g., pedestal, walls, wafer, etc.) at or close to ground potential.

5 In the present embodiment, the wave adjustment circuit 127 is a variable coil portion 128 of a spiral transmission line, which is selectively placed outside the outer shield 133. Accordingly, when the wave adjustment circuit is adjusted to become a short circuit, the plasma source "sees" only a selected full-wave multiple comprising substantially equal phase 151 and anti-phase 153 of the entire instantaneous AC voltages 134, 135. In this embodiment, stress of the deposited oxide film is often tensile, which can be undesirable.

10 Alternatively, the wave adjustment circuit 127 provides a helical resonator operating at selected phase and anti-phase voltages that are not full-wave multiples. This wave adjustment circuit provides for a selected amount of capacitive coupling from the plasma source to the chamber bodies. Stress of the deposited oxide film in this embodiment can be made to be zero or slightly compressive. In some embodiments, the oxide films can be deposited with an rf plasma potential of several hundred volts between the plasma source and the substrate to decrease the tendency of the oxide film to absorb moisture. This can occur by adjusting the wave adjustment circuit to add in a small section of transmission line outside of the source and correspondingly shortening the applicator coil (by moving the lower point at which the applicator coil is short-circuited and thereby decreasing the inductance of the applicator coil and electrical length of the helical resonator 126 (e.g., spiral transmission line, etc.)). Of course, the selected amount of capacitive coupling will depend upon the application.

25 Fig. 4 is a simplified diagram of a resist stripper according to the present invention. The present stripping apparatus includes similar elements as the previous described CVD apparatus. The present stripping apparatus includes a chamber 112, a feed source 114, an exhaust 116, a pedestal 118, an rf power source 122, a ground 124, a helical resonator 126, and other elements. The helical resonator 126 includes a coil 132, an outer shield 133, a wave adjustment circuit 400, and other elements. The chamber can be any suitable chamber

30

capable of housing a product 119 such as a photoresist coated wafer for stripping, and for providing a plasma discharge therein. The plasma discharge is derived from a plasma source, which is preferably a helical resonator discharge or other inductive discharge using a wave adjustment circuit or other techniques to  
5 selectively adjust phase\anti-phase potentials. The present stripping apparatus provides for stripping or ashing photoresist, e.g., implant hardened, etc. Further examples of such a stripping apparatus are described in the experiments section below.

In this embodiment, the wave adjustment circuits rely upon open  
10 circuits (i.e., zero susceptance). Power transfer can be occurred with a balanced feed such as an inductively-coupled push-pull arrangement such as coupled inductors. Techniques for constructing these coupled inductors are described in, for example, "The ARRL Antenna Book," R.D. Straw, Editor, The American Radio Delay League, Newington, CT (1994) and "The Radio Handbook," W.I.  
15 Orr, Editor, Engineering Ltd, Indiana (1962), which are both hereby incorporated by reference for all purposes. In one embodiment, a ferrite or powdered iron core "balun" (balanced-unbalanced) toroidal transformer (i.e., broadband transmission transformer, broadband transformer, etc.) 401 can be used to provide balanced  
20 matching from a conventional unbalanced coaxial transmission line. Techniques for constructing toroidal baluns are described in, for example, "Transmission Line Transformers," J. Sevick, 2nd Edition, American Radio Relay League, Newington, CT (1990). The toroidal transformer is coupled between the rf power source 122 and the coil 132. The midpoint 406 between the phase 405 and anti-  
25 phase voltage on the coil is effectively rf grounded, hence it may be convenient to directly ground this midpoint of the inductive application in some embodiments for stability. This permits alternate operation in which power may be coupled into the inductive applicator (e.g., coil, etc.) with a conventional unbalanced feed line tapped on one side of the center. Push-pull balanced coupling ignites the plasma  
30 more easily than conventional unbalanced coil tap matching and generally is easier to adjust in selected applications.

Referring to the helical resonator embodiments operating at

substantially equal phase and anti-phase potentials, Fig. 5A is a simplified diagram 200 of an equivalent circuit diagram of some of them. The diagram is merely an illustration and should not limit the scope of the claims herein. The equivalent circuit diagram includes a plurality of rf power supplies ( $V_1, V_2, V_3 \dots V_n$ ) 203, 5 representing for example, a single rf power source. These power supplies are connected in parallel to each other. One end of the power supply is operably coupled to a ground connection 201. The other end of the power supplies can be represented as being connected to a respective capacitor ( $C_1, C_2, C_3 \dots C_n$ ). Each of these capacitors are connected in parallel to each other. During this mode of 10 operation, substantially no voltage difference exists between any of these capacitors, as they are all connected to each other in parallel.

Fig. 5B is a simplified diagram of instantaneous AC voltage and current along a helical resonator coil of Fig. 5A where each end of the inductive applicator is short circuited. The diagram is merely an illustration and should not 15 limit the scope of the claims herein. This diagram includes the discharge tube 213 and an inductive plasma discharge (or plasma source) 501 therein. As shown, the plasma discharge includes an intensified "donut-shaped" glow region 501 that occupies a limited range (R) of the discharge tube 213. The plasma discharge has an average voltage potential ( $V_{ave}$ ) of substantially zero volt between the ground 20 potential ( $V_G$ ) and the high voltage potential ( $V_H$ ). As can be seen, the plasma discharge 501 has capacitively coupling elements to  $V_H$  and  $V_G$ . But the average voltage potential of this plasma discharge is zero. This operation provides for balanced capacitance of phase 503 and anti-phase 505 voltages along the coil adjacent to the plasma, thereby substantially preventing capacitively coupling from 25 the plasma source to chamber bodies. As also shown, a current maxima 507 exists at  $V_{ave}$ , which corresponds to an inflection point between the phase 503 and the anti-phase 505.

In an alternative operating mode, dim rings of plasma caused by inductively coupled plasma current are visible near top and bottom extremes of the 30 inductive application, as illustrated by Fig. 5C. This operating mode is generally for a full-wave 517 inductive coupling coil operated at a very high power, e.g.,

maximum power input to the inductive applicator is often limited by thermal considerations and breakdown. The rings 513, 515 of current in the plasma discharge are simulated by maximum coil current areas corresponding to voltage minima at the top and bottom shorted ends of the coil. Under these high power conditions, subordinate current rings are detectable and some excitation is often visible in the intermediate regions. This excitation is partially caused by capacitively driven currents within the discharge coupled to the voltage maximum and voltage minimum positions along the inductive applicator.

Alternatively, subordinate inductive plasma current rings at the top and bottom ends 513 of the resonator do not appear with limited input power. The coil current and inductive flux fall beyond the ends of the inductive applicator so that a single inductive ring 515 in the center portion is more stable, provided that the conductivity of the plasma is large enough to support a single current ring at a specified input power.

In alternative applications using high power operation, no secondary plasma current rings may be desirable. These applications often have substantially minimum internal capacitive coupling. In these applications, the inductive applicator (e.g., coil) abutting the vacuum vessel may be shortened from a full wave to an appropriate length such that only the central current maxima exists on the coil abutting the plasma source and the potential difference between maximum and minimum voltage on the applicator is substantially reduced. The present application is achieved by stabilizing the desired waveform along the applicator by appropriate impedance wave adjustment circuits.

Referring to the above embodiments, the present invention provides for processing with an inductively coupled plasma in which the plasma potential from coupling to a phase portion of the inductive applicator is substantially not offset by capacitive coupling to anti-phase voltages on selective portions to the inductive coupling element. Conventional inductive sources (e.g., conventional helical resonators, etc.), however, have hitherto been operated in quarter-wave or half-wave modes. These modes provide only phase capacitive coupling to the plasma, which raises the plasma potential toward the coil without compensation

anti-phase coupling. Conventional inductive sources that are longer than a half-wave have been generally considered cumbersome and impractical for plasma reactors. In particular, these inductive sources are large in size, and have nodes along the helical coil, which have been believed to create a non-uniform plasma. In order to operate a substantially inductive plasma in a helical resonator, conventional inductive sources relied upon shielding the plasma tube from electrical fields originating on the coil. Shielding occurred, for example, by inserting a longitudinally split shield between the coil and plasma tube.

The present invention provides for a substantially pure inductively coupled power source. A benefit of this inductively coupled power as a primary means to sustain plasma excitation is that electric field lines produced by inductive coupling are solenoidal (e.g. they close on themselves). Since solenoidal electric field lines have zero divergence, they do not create or support a scalar potential field (e.g. a voltage difference) within the plasma volume. Thus, in an ideal case, inductively coupled power can be transferred into a plasma without no direct relationship between the plasma potential and the voltages on coupling elements (e.g. the voltage on the coil in a helical resonator) or voltages on rf matching networks, if such are used. Furthermore, when transferring power to the plasma by purely inductive means, power transfer does not require any significant potential difference to be maintained between elements of the plasma and ground potential (e.g. the potential difference between the plasma and ground can be fixed by factors which are substantially independent of inductive excitation power). Although in theory, inductive power transfer does not require raising the AC or DC potential of the plasma with respect to ground, in practice there has been substantial shift and harmful alteration in the plasma potential found in unshielded current art inductive sources.

As previously noted, and further emphasized herein, the most effective conventional method employed to avoid plasma potential shift in conventional commercially available inductive sources is to shield the plasma from the electrical fields on the inductive coupling element (commonly a multi-turn coil) by inserting a grounded conductive member between the inductive driving element

and the plasma discharge tube. Shielding is, however, cumbersome and inconvenient and has serious disadvantages in practice. Shields couple to inductive applicator elements and can cause wide excursions in the natural resonance frequency, which are not predicted by conventional design formulae. This often results in laborious trial and error and iterative mechanical designs to achieve a desired resonance. Another disadvantage of shielding is that shields often make it difficult to achieve initial ignition of the plasma since shields generally exclude capacitive electric fields in the plasma discharge tube. In particular, ignition (known as plasma breakdown) of inductive breakdown generally begins with a capacitive electric field discharge, which is stable at lower currents and powers (See, for example, J. Amorim, H.S. Maciel and J.P. Sudana, J. Vac. Sci. Technol. B9, pp. 362-365, 1991). Accordingly, shields tend to block capacitive electric fields, which induce plasma ignition.

Insertion of the shield close to high voltage RF point in a network (such as the voltage maximum points in a helical resonator or the high potential driven side of a TCP coil) also causes large displacement currents to flow through the capacitance between the shield and coil. This high potential difference is also a potential cause of damaging rf breakdown across the air gap, hence the gap may require protection by inconvenient solid or liquid dielectric insulation. The displacement current flow causes power loss and requires that higher power RF generating equipment be used to compensate for the power loss. Coupling loss in the plasma source structure is also undesirable from the standpoint of thermal control. These limitations are overcome by the present invention using the wave adjustment circuits, an inductive applicator of selected phase length, and other elements.

#### Experiments

To prove the principle and demonstrate the operation of the present invention, a helical resonator plasma source was used in a photoresist stripper. Conventional helical resonators also were evaluated in these experiments. These experiments are merely examples, and should not limit the scope of the claims

herein. One of ordinary skill in the art would easily recognize other experiments, uses, variations, and modifications of the inventions defined by these claims.

#### I. Conventional Photoresist Stripper

5 In this experiment, the conventional resist stripper was a prototype made by MC Electronics, present assignee. Of course, other stripper platforms also can be used depending upon the application. A conventional quarter-wave helical resonator resist stripper 600 was constructed with a quarter-wave helical resonator source 602 upstream of a processing chamber 604, shown in Fig. 6.  
10 This quarter-wave helical resonator 602 included a coil 608 and other elements.

Coil 608 consisted of 5.15 turns of 0.4 inch diameter copper tubing would with a pitch of 0.5 turns per inch with a mean radius of 6.4 inches and centered radially and vertically inside an outer copper shield 610. Coil 608 is operably coupled to a power source 612 and operated at about 13 MHz radio  
15 frequency. A 17 inch long, 9.25 inch diameter quartz tube 606 was centered inside of the copper coil 608. The shield 610 was 16 inches inside diameter, approximately 0.08 inches thick and 18 inches long. This shield 610 also was connected to a ground ( $V_G$ ) connection on the aluminum process chamber body (except when making the current measurements described below).

20 The process chamber 604 was for a conventional resist stripper. This resist stripper included a wafer support 616 (or pedestal) and other elements. Process chamber 604 is operably coupled at an outer location 620 to ground via shield 610. Wafer support 616 has a wafer 618 disposed thereon.

25 The wafer 618 is a 6-inch (250mm) <100> type wafer with approximately 1.25 microns of spin-coated Mitsubishi Kasei positive photoresist MPR-4000. This wafer was ashed on the grounded 10 inch diameter wafer support 616. This support was resistivity heated and the temperature of the substrate support was sensed with a thermocouple.

30 After the helical resonator plasma was ignited, visible plasma filled the quartz plasma tube under all of the conditions used for processing. In addition, a strong plasma glow was always visible above the wafer in the downstream



processing chamber which was indicative of secondary plasma discharge to the substrate support. This secondary plasma discharge was also accompanied by current flow from the resonator shield to the chamber of approximately 5-10 Amperes rms (and sometimes even more) which could be measured by elevating the shield on insulating blocks and monitoring the current flow through a 2 inch long 1.5 inch wide strip of copper braid which was passed through a Pearson Current probe used to monitor the current.

Fig. 7 is a simplified diagram 700 of the rf voltage distribution along the coil for the quarter-wave helical resonator of Fig. 6. This diagram includes the quartz tube 606 and a plasma discharge (or source) 701 therein. As shown, the plasma discharge includes a glow region that 701 occupies a large range (R) of the quartz tube 606. The plasma discharge has an average voltage potential ( $V_{ave}$ ) between the ground potential ( $V_G$ ) and the high voltage potential ( $V_H$ ). As can be seen, the plasma discharge 701 has capacitively coupling elements to  $V_H$  and  $V_G$  due to its average voltage potential  $V_{ave}$ . In fact, as previously noted, the current flow from the resonator shield to the chamber was at least 5-10 Amperes rms. In high power applications, intense sparking was observed in the chamber from the capacitively coupled plasma source.

## II. Present Photoresist Stripper

To prove the principle and operation of the present inventions, experiments were performed. These experiments used a photoresist stripper apparatus. This resist stripper apparatus in a cluster tool arrangement used a helical resonator according to the present inventions. One of ordinary skill in the art, however, would recognize that other implementations, modifications, and variations may be used. Accordingly, the experiments performed herein are not intended to limit the scope of the claims below.

The photoresist stripper apparatus was configured with multiple process chambers in a cluster tool arrangement, as illustrated by Figs. 8 and 9. Figs. 8 and 9 illustrate a simplified top-view diagram 800 and a simplified side-view diagram, respectively. Two process chambers, e.g., chamber 1 901 and

chamber 2 903, were used. Chamber 1 901 was used for stripping implant hardened resist crust (or skin). Chamber 2 903 was used for stripping the remaining photoresist. Alternatively, the chambers can be both used for stripping implant hardened resist crust and stripping remaining photoresist. Of course, the particular use depends upon the application. These chambers also were made of aluminum with ceramic inserts, which is highly resistant to chemical attack.

The apparatus also used a microprocessor based controller to oversee process operations. This microprocessor based controller can be accessed through a control panel 921. The present apparatus used a controller made from a 486DX processor PC made by EPSON, with a color LCD touch panel display. This controller also is shielded and highly resistant to chemical attack.

An automatic wafer handling system 910 was also provided. The automatic wafer handling system used standard cassettes 912 for transferring the photoresist coated wafers to and from the process chambers 901, 903. The automatic wafer handling system included a robot 917, cassette chamber 1 905, cassette chamber 2 907, cassette stage 1 909, cassette stage 2 911, and other elements. The wafer handling system 910 used a conventional interlock system for providing the cassettes 912 from the cleanroom into the process chambers 901, 903. A main shuttle chamber 913 housed the robot 917 in the cluster tool arrangement. The controller oversees the automatic wafer handling system operations. The present wafer handling system is made by JEL Co., LTD of Japan.

A cooling plate 915 was included in the main chamber 913 housing the robot 917. The cooling plate 915 was of conventional design, and was capable of cooling the wafer after being stripped, which often occurs at elevated temperatures. Alternatively, the cooling plate can be used to thermally adjust the wafer temperature either before, after, or even between selected process operations.

The process chambers 901, 903 were disposed downstream from respective plasma sources 923, 925. Each helical resonator included a coil 927 disposed around a quartz tube 929. The coil consisted of 11.5 turns of 0.4 inch

copper tubing wound with a pitch of 0.9 turns per inch with a mean radius of 9.4 inches and centered radially and vertically inside an outer copper shield 931. The coil is operably coupled to a power source (not shown). A 17 inch long, 9.25 inch diameter quartz tube was centered inside of the copper coil. The shield was 16  
5 inches inside diameter, approximately 0.08 inches thick and 18 inches long. The shield is operably coupled to a lower portion of the coil.

In one experiment, processes were used for stripping photoresist from wafers, e.g., See Fig. 9 reference numeral 933. The processes involved the use of a multi-step stripping operation to remove implanted photoresist from  
10 semiconductor wafers. Samples were prepared using eight-inch wafers. These wafers were spin coated with Mitsubishi Kasei positive photoresist MPR-4000. Spin coating occurred at 1,200 rpm and 120 °C for 90 seconds. The resulting photoresist was about 1.2 microns in thickness in the sample wafers. These sample wafers were implanted to form a implanted hardened resist layer near the  
15 top of the photoresist.

An implant resist stripping process was performed to remove the top implant hardened resist. This occurred by stripping using an "un-balanced" phase and anti-phase coupling relationship in a half-wave helical resonator. The half-wave helical resonator was configured in one of the process chambers. In this  
20 chamber, the pedestal had a temperature of about 40 °C to maintain a low wafer temperature. This low wafer temperature was maintained to reduce the possibility of "popping." Popping occurs when vapor in the underlying photoresist explodes through the implant hardened resist.

After the top hardened layer was removed. The wafer was  
25 transferred into a chamber operating at a full-wave multiple. This chamber operated at a frequency of about 27.12 MHz at a full-wave multiple. The pedestal of this chamber was at 150 to 200 °C. The full wave structure provided for balanced phase and anti-phase coupled currents, thereby reducing the amount of capacitively coupled plasma, which can be detrimental to the underlying substrate.  
30 In this step, overashing was performed to substantially remove all photoresist material from the wafer. No damage occurred to the underlying substrate during

this overashing step.

Once the photoresist has been stripped, the wafer is cooled. In particular, the wafer is removed from the full-wave multiple process chamber, and placed on the cooling station. This cooling station reduces the temperature of the wafer (which was heated). This wafer is then reloaded back into its wafer cassette. Once all wafers have been processed in the cassette, the cassette comprising the stripped wafers is removed from the cluster tool apparatus. Characteristics of this half-wave helical resonator were described in detail above. In the present experiments, the following tests also were performed.

Test 1: 6-inch wafers were ashed at a total pressure of 0.13 Torr using a gas flow of 0.2 standard liter per minute of pure oxygen, forward rf power of 2200 watts and a reflected power of 150 watts at an excitation frequency of 13.4 Mhz. The substrate was held at 60 °C and wafers were ashed and then the discharge was extinguished). The ashing rate across the wafer was determined to vary between approximately 3411 Å/min and 3139 Å/min with the rates approximately symmetric about the center of each wafer and the maximum ashing rate at the center. The average etching rate was 3228 Å/min and etching uniformity was approximately 4 percent.

Test 2: 6-inch wafers were ashed at a total pressure of 1 Torr using a gas flow of 1 standard liter per minute, forward rf power of 2200 watts and a reflected power of 160 watts at an excitation frequency of 13.0 MHz. The substrate was held at 60 °C and the ashing rate was determined to vary between approximately 3144 Å/min and 3748 Å/min depending on position on a wafer. The etching uniformity was approximately 9 percent.

Test 3: Resist coated wafers were implanted with a selected dose of  $5 \times 10^{15}$  atoms/cm<sup>2</sup> at 40 kev arsenic (As). The wafers were cleaved into samples approximately 3 centimeters square.

Two samples were then ashed on the substrate support simultaneously, under the various conditions listed in Table 1.

TABLE 1: Experimental Results for Ashing

Run	Time(s) (sec.)	Pressure (Torr.)	O <sub>2</sub> Flow (slm)*	Fwd Pwr (W)	Ref. Pwr (W)	rf freq. (MHz)	Temp (°C)
A	180	0.23	0.5	2,000	180	13.2	68
B	132	0.06	0.2	2,150	180	13.3	90
C	180	0.13	0.2	2,200	150	13.3	60
D	300	0.13	0.2	2,200	150	13.3	40
E(I)	90	0.09	0.1	2,200	80	13.4	40
F(II)	150	0.09	0.1	2,200	80	13.4	40

\*slm=standard liters per minute (or 1000 sccm)

(I) Unimplanted resist was used in this test and ashing was terminated before endpoint was reached to test uniformity. The average ashing rate was 5259 Å/min and uniformity was 7.5%.

(II) Implanted resist was etched for 150 sec, but endpoint was visible at 100 seconds.

Under conditions used for Run D, it was determined that resist was cleared from the entire wafer after 3 minute and 15 seconds. Consequently, the ashing time in the table included approximately 100 sec. overetching. Under conditions where practical ashing rates were attained, a visible plasma discharge and sheath could be observed over the wafer.

Diagnostic measurements of current similar to those performed in the conventional stripping apparatus were performed. In these measurements, currents from the shield of the resonator to the processing chamber gave values of at about 0.1 to 0.5 Amperes rms and less. These measurements were limited by error using available instrumentation. Accordingly, these currents were at least an order of magnitude below those currents measured above in the conventional stripping apparatus.

A visual inspection of the stripped wafers shows extremely good

5 results. That is, the wafers were stripped at a sufficient rate for production operation and no substantial damaged occurred to the wafers. This provides for effective wafer turn-around-time and substantially no damage caused by the plasma. In addition, current measured from the shield to the chamber by elevating the shield on insulating blocks was less than about 0.5 Amperes rms and, in some instances, at or below measured error using available instrumentation. This current was substantially less than those measured in the conventional stripping apparatus.

10 While the invention has been described with reference to specific embodiments, various alternatives, modifications, and equivalents may be used. In fact, the invention also can be applied to almost any type of plasma discharge apparatus. This discharge apparatus can include an apparatus for plasma immersion ion implantation or growing diamonds, TCPs, and others. This discharge apparatus can be used for the manufacture of flat panel displays, disks, 15 integrated circuits, diamonds, semiconductor materials, bearings, raw materials, and the like. Therefore, the above description should not be taken as limiting the scope of the invention which is defined by the appended claims.

WHAT IS CLAIMED IS:

- 5 1. A process for fabricating a product, said process comprising the steps of subjecting a substrate to entities, at least one of said entities emanating from a species generated by a gaseous discharge excited by a high frequency field in which the vector sum of phase portion and anti-phase portion of capacitive current coupled from the inductive coupling structure balances.
- 10 2. The process of claim 1 wherein said product comprises a semiconductor device.
- 15 3. The process of claim 1 wherein said gaseous discharge is provided by a helical resonator.
- 20 4. The process of claim 1 wherein said gaseous discharge is provided by a helical resonator having an electrical length which is substantially a whole number multiple of one wavelength.
- 25 5. The process of claim 1 wherein said gaseous discharge is provided by a helical resonator structure, said helical resonator structure having an electrical length which is substantially free from any multiple of one quarter wavelength.
- 30 6. The process of claim 1 wherein said one of said entities is provided in chemical vapor deposition.
7. The process of claim 1 wherein said one of said entities is provided in plasma etching.
8. The process of claim 1 wherein said inductive coupling structure is selectively balanced using a wave adjustment circuit.

5 9. A process for fabricating a product comprising the steps of  
subjecting a substrate to a composition of entities and employing the resulting  
substrate for completion of said product, at least one of said entities emanating  
from a species generated by a gaseous discharge provided by a helical resonator,  
said helical resonator having an integral current driven by capacitive coupling of  
plasma column to elements with a selected potential greater than a surrounding  
shield potential is substantially equal to capacitive coupling of the plasma column  
to substantially equal elements with a potential below shield potential.

10 10. The process of claim 9 wherein said helical resonator is  
characterized in that the capacitive current flow from the surrounding coil into the  
plasma column is substantially equal to the capacitive current from the plasma  
column to the surrounding coil.

15 11. The process of claim 9 wherein said helical resonator is in  
which the average potential of the plasma column is substantially equal to that of  
the shield.

20 12. Apparatus for fabricating a product, said apparatus comprising:  
an enclosure comprising an outer surface and an inner surface, said  
enclosure housing a gaseous discharge;  
a plasma applicator disposed adjacent to said outer surface;  
a high frequency power source operably coupled to said plasma  
applicator, said high frequency power source exciting said gaseous discharge to  
25 provide at least one entity from a high frequency field in which the vector sum of  
phase and anti-phase capacitive current coupled from the inductive coupling  
structure substantially balances.

30 13. Apparatus of claim 12 wherein said enclosure is a chamber.

14. Apparatus of claim 12 wherein said enclosure is a tube.



15. Apparatus of claim 14 wherein said tube is made of a material selected from quartz, glass, diamond, polymer, sapphire, and alumina.

5 16. Apparatus of claim 12 wherein said apparatus further comprises a wave adjustment circuit, said wave adjustment circuit operably coupled to said plasma applicator to selectively provide balancing of said inductive coupling structure.

10 17. Apparatus of claim 12 wherein apparatus is provided for chemical vapor deposition.

18. Apparatus of claim 12 wherein apparatus is provided for plasma etching.

15 19. Apparatus of claim 12 wherein said enclosure, said plasma applicator, and said high frequency power source define a helical resonator structure, said helical resonator structure having an electrical length which is substantially a whole number multiple of one wavelength.

20 20. Apparatus of claim 12 wherein said enclosure, said plasma applicator, and said high frequency power source define a helical resonator structure, said helical resonator structure having an electrical length which is substantially free from any multiple of one quarter wavelength.

PROCESS DEPENDING ON PLASMA DISCHARGES SUSTAINED  
BY INDUCTIVE COUPLING

ABSTRACT OF THE DISCLOSURE

5 A process for fabricating a product 28, 119 . The process  
comprises the steps of subjecting a substrate to a composition of entities, at least  
one of the entities emanating from a species generated by a gaseous discharge  
excited by a high frequency field in which the vector sum of phase and anti-phase  
capacitive coupled voltages from the inductive coupling structure substantially  
10 balances.

10

15

H:\home\rt\work\16655\3.ap1

16655-3

DB/567224

1/3

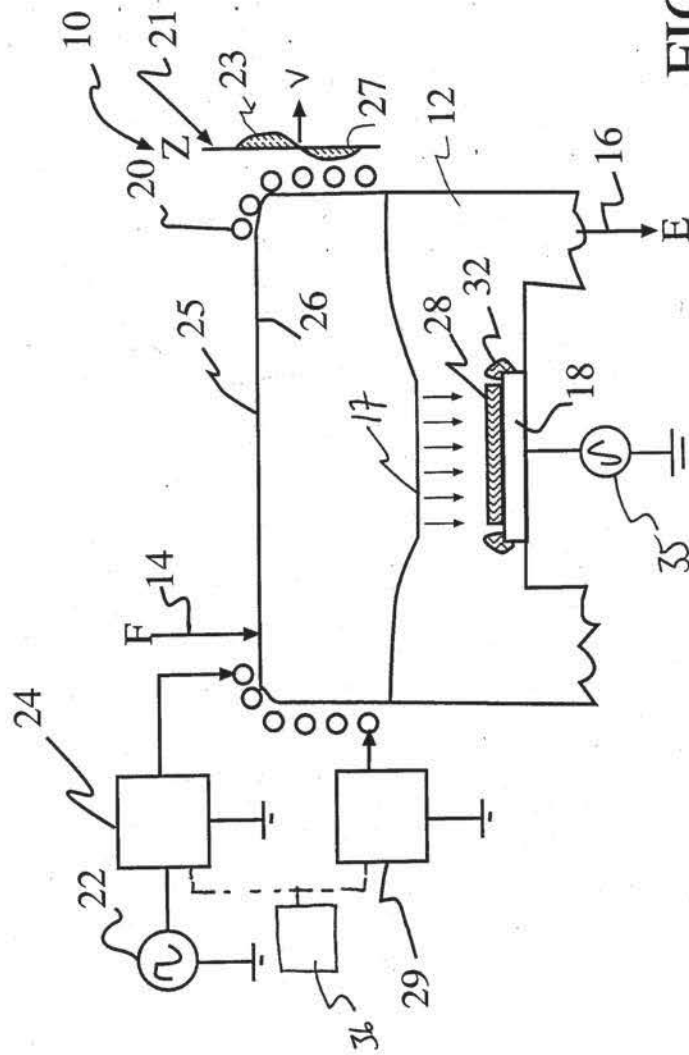

FIG. 1

16655-3

08/567224

2/13

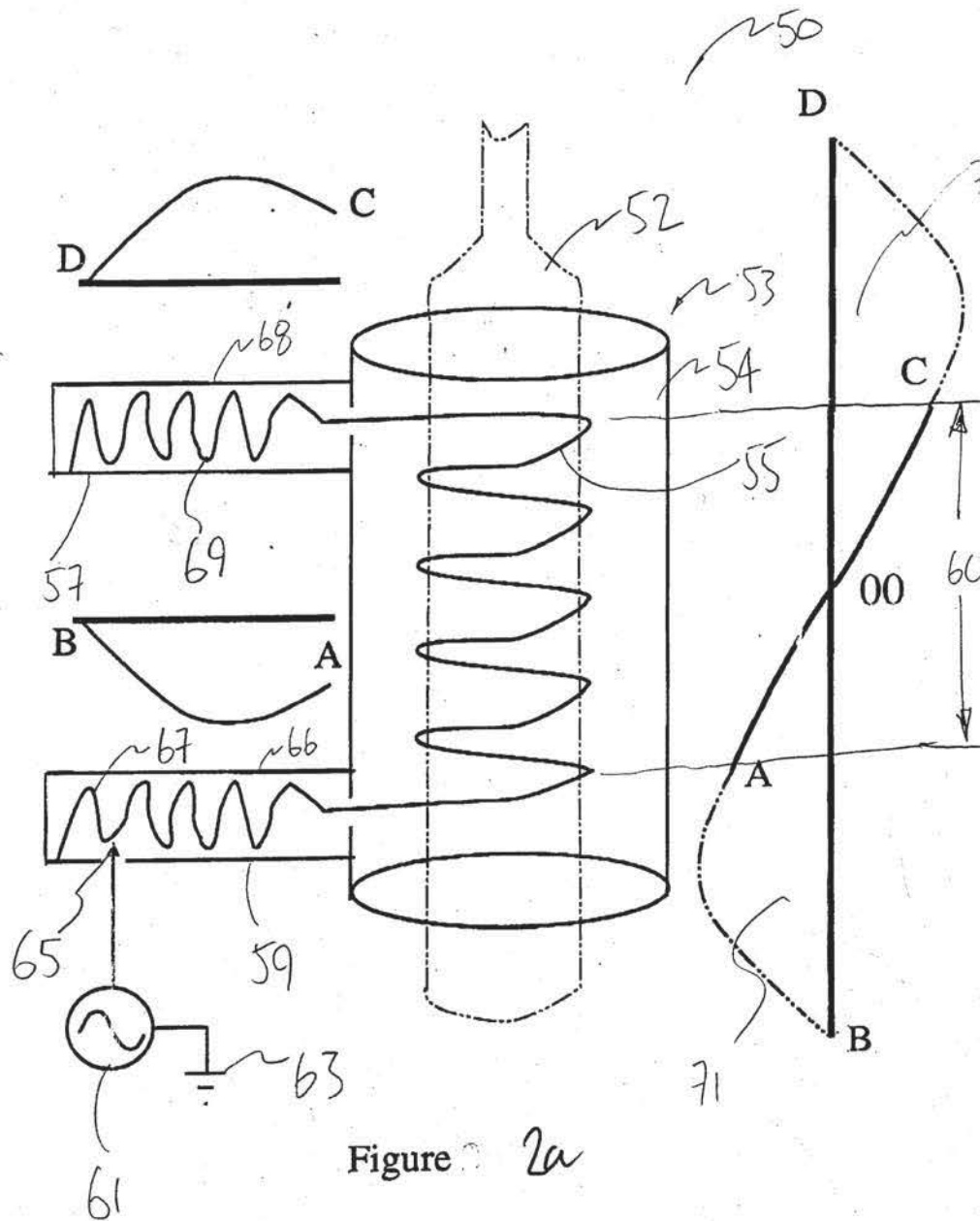

Figure 2a

16655-3

DB/567224

3/13

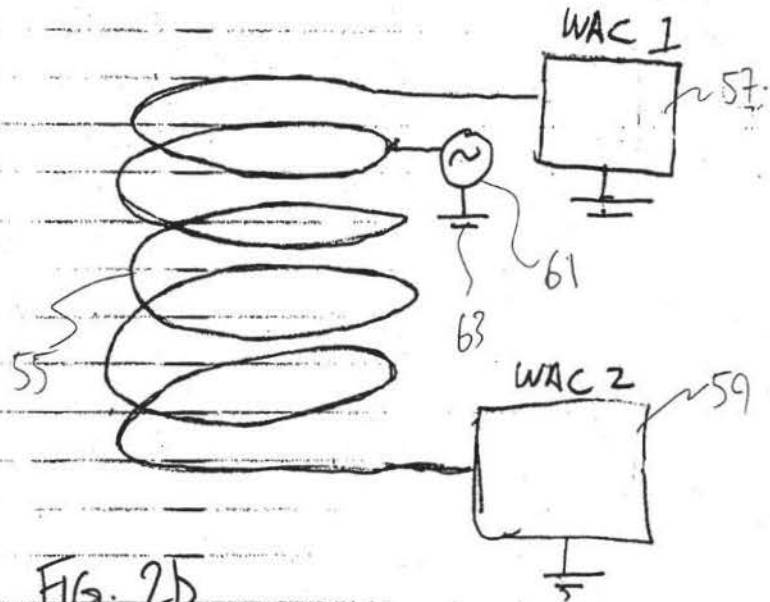

FIG. 2B

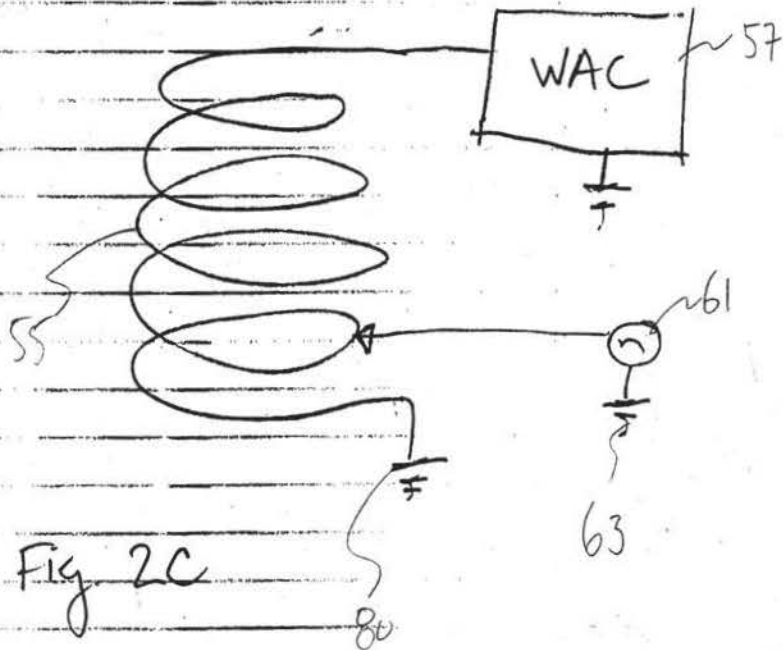

Fig 2C

16655-3

08/567224

4/B

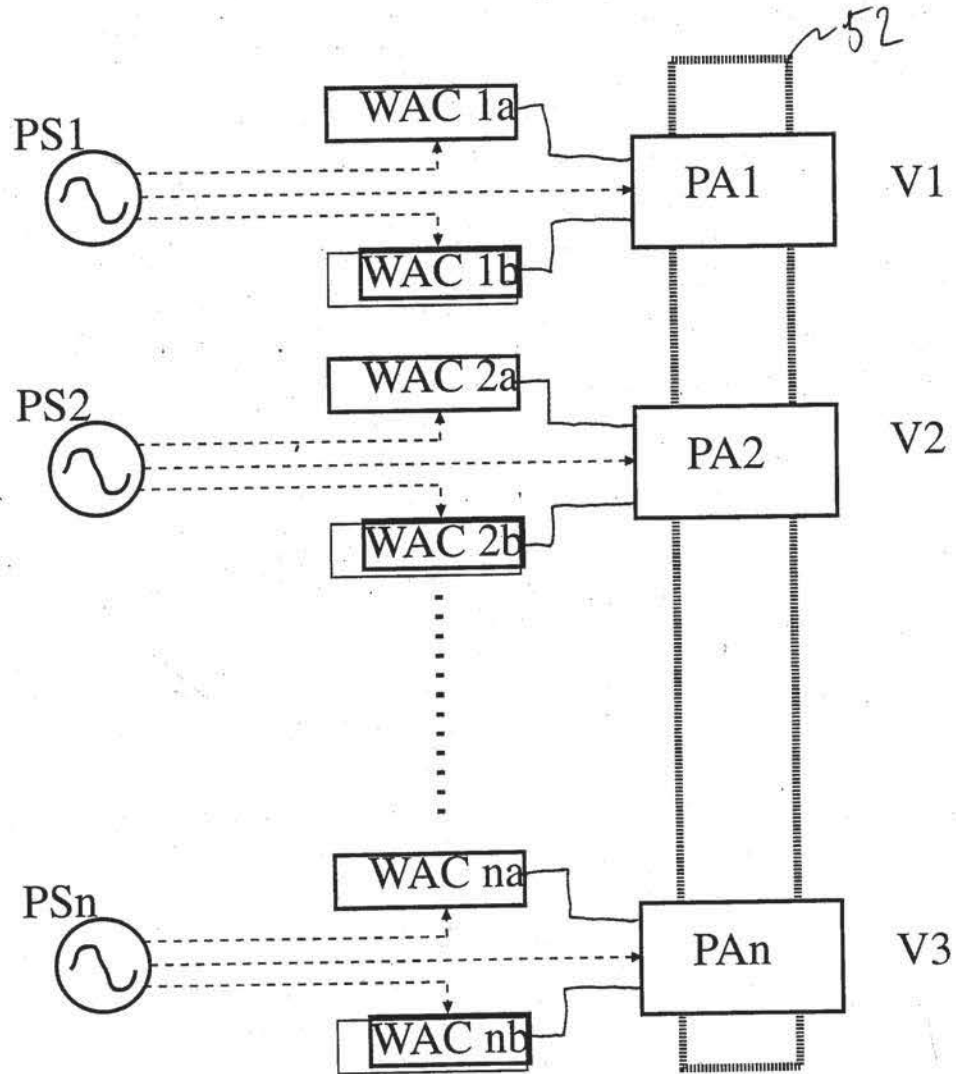

Fig. 2d

16655-3

08/567224

5/B

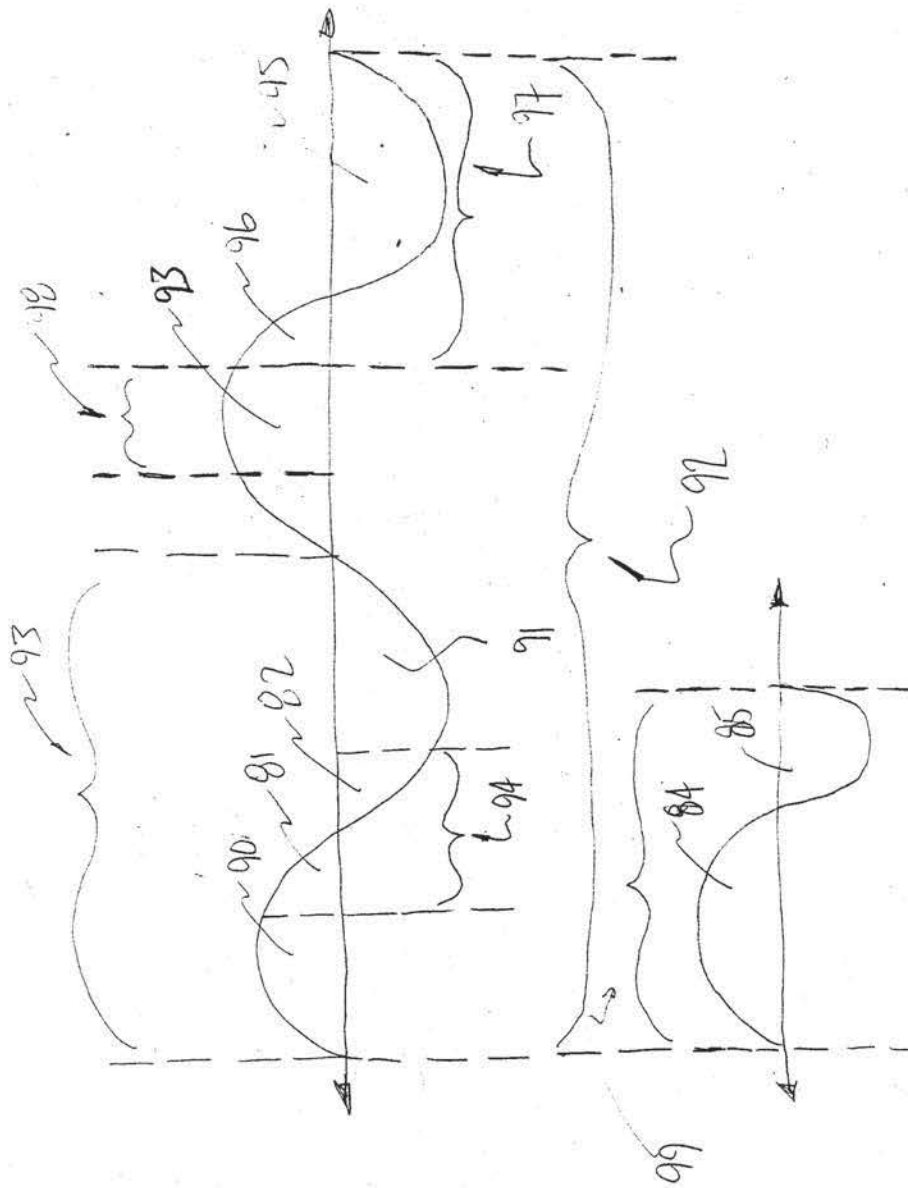

FIG. 2E

16655-3

08/567224

6/13

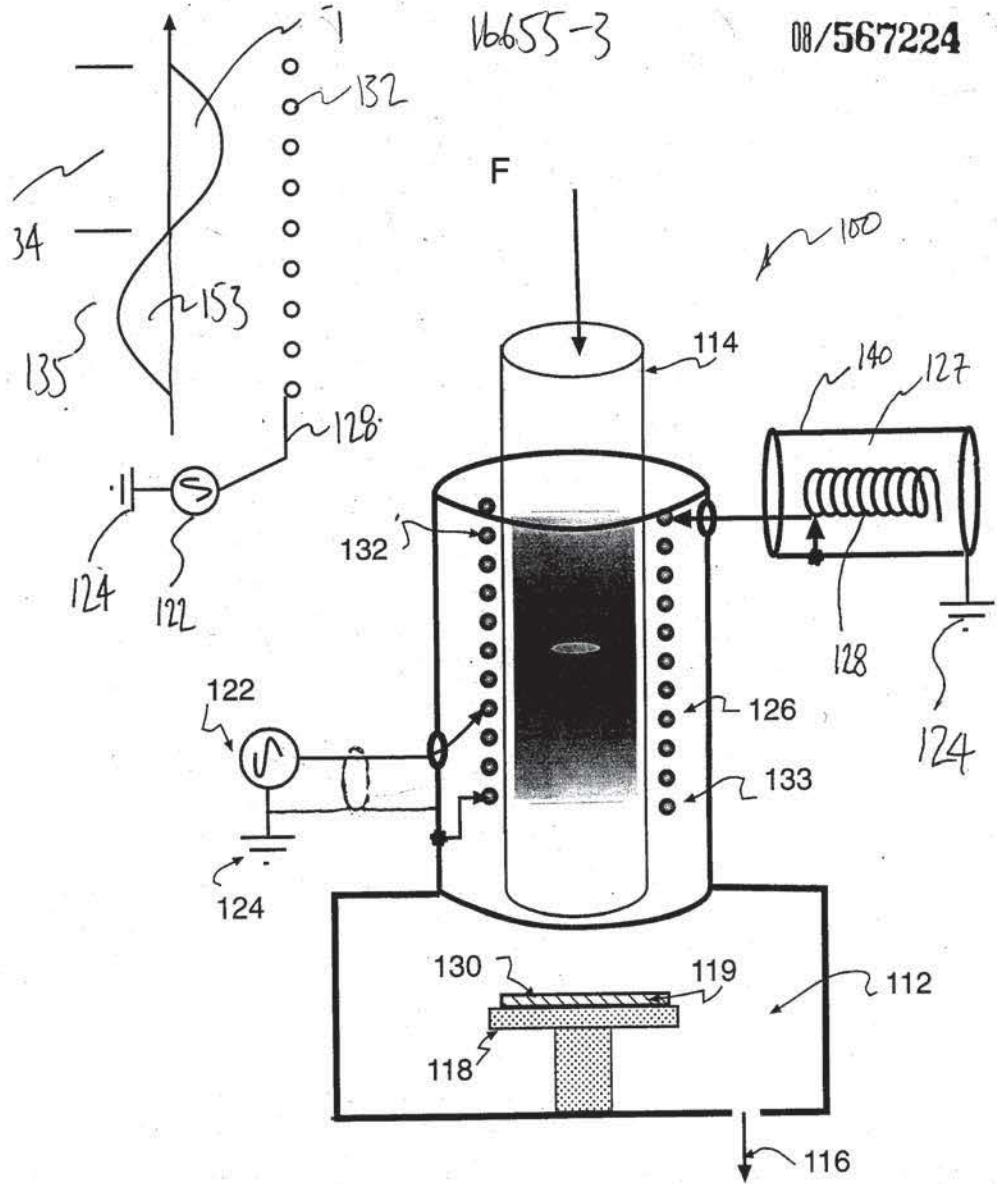

Fig 3



16655-3

08/567224

7/13

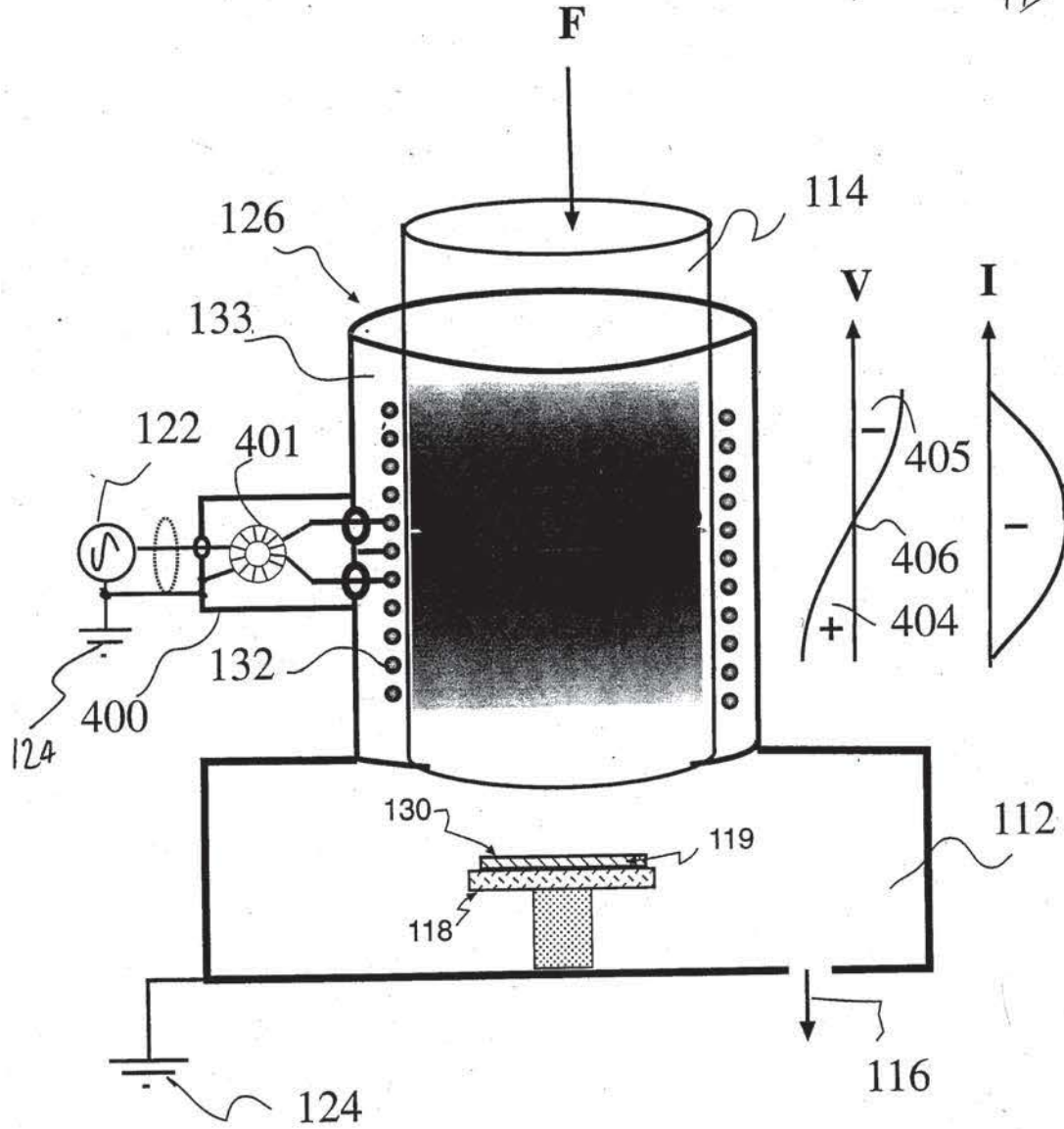

Fig. 4

16655-3

08/567224

8/13

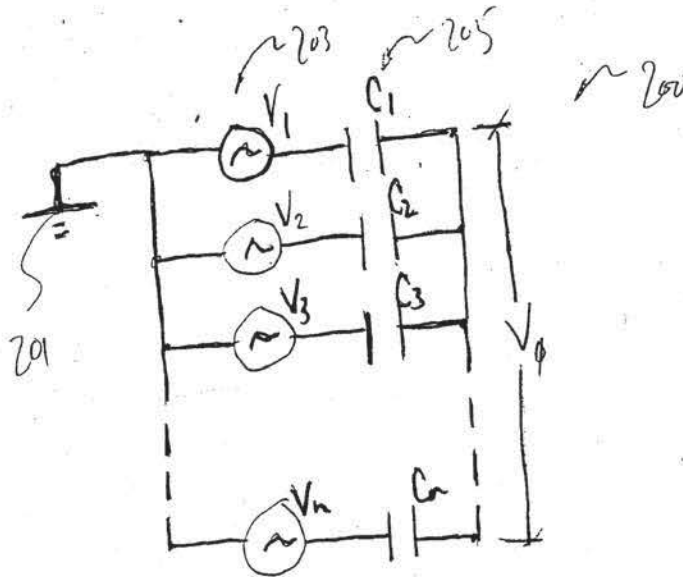

FIG. 5A

16655-3

08/567224

9/13

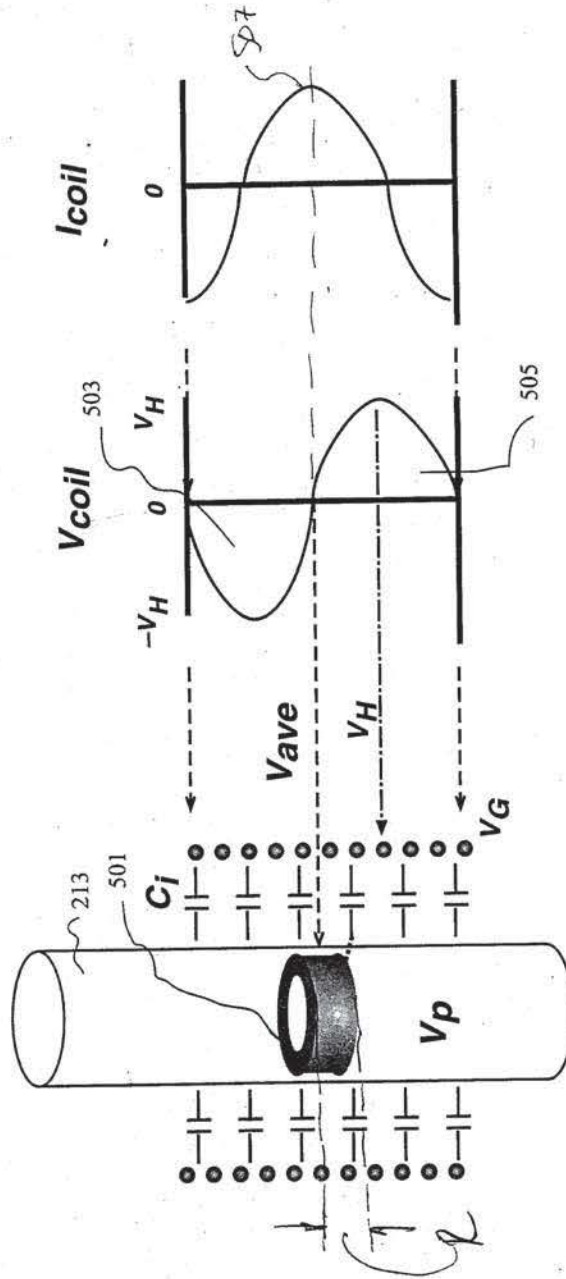

FIG. 5B

FUNDAMENTAL STRUCTURE  
OF FULL WAVE HELICAL RESONATOR  
DISCHARGE  
16655-3

08/567224 <sup>10/13</sup>

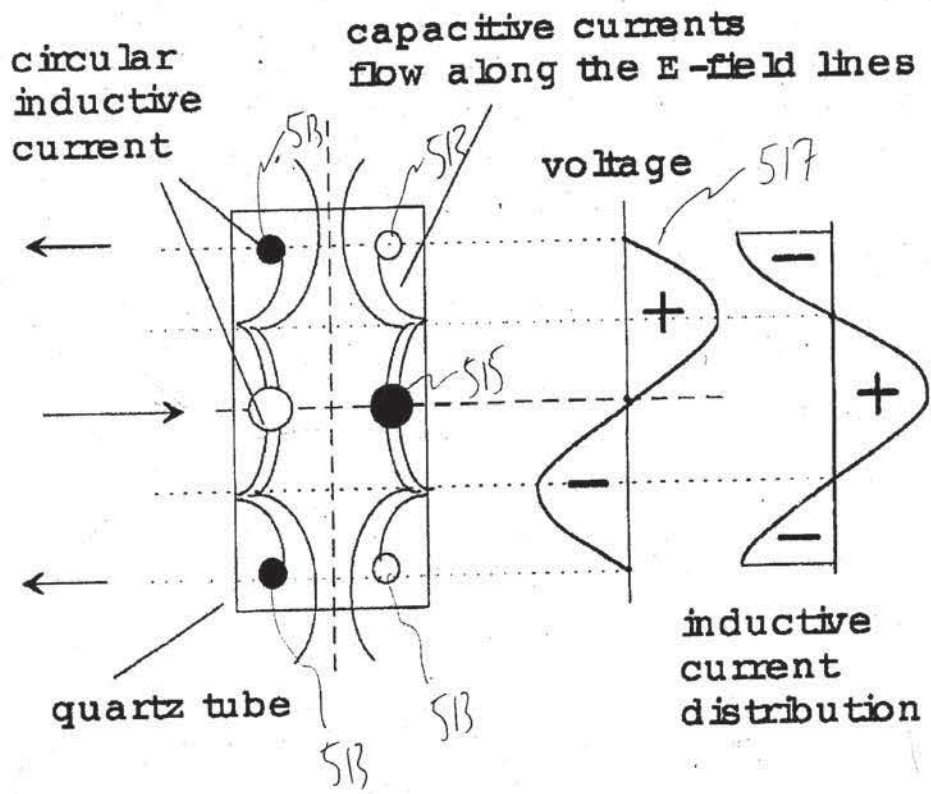

FIG. 5C

16655-3

08/567224

4/13

600

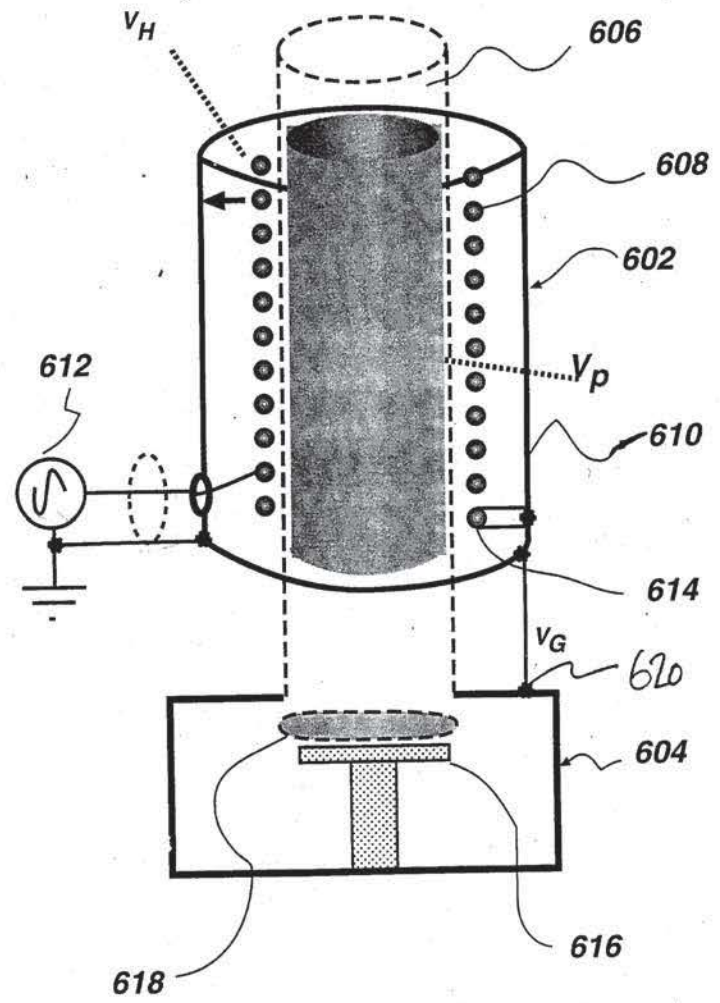

Fig. 6

16655-3

08/567224

12/113

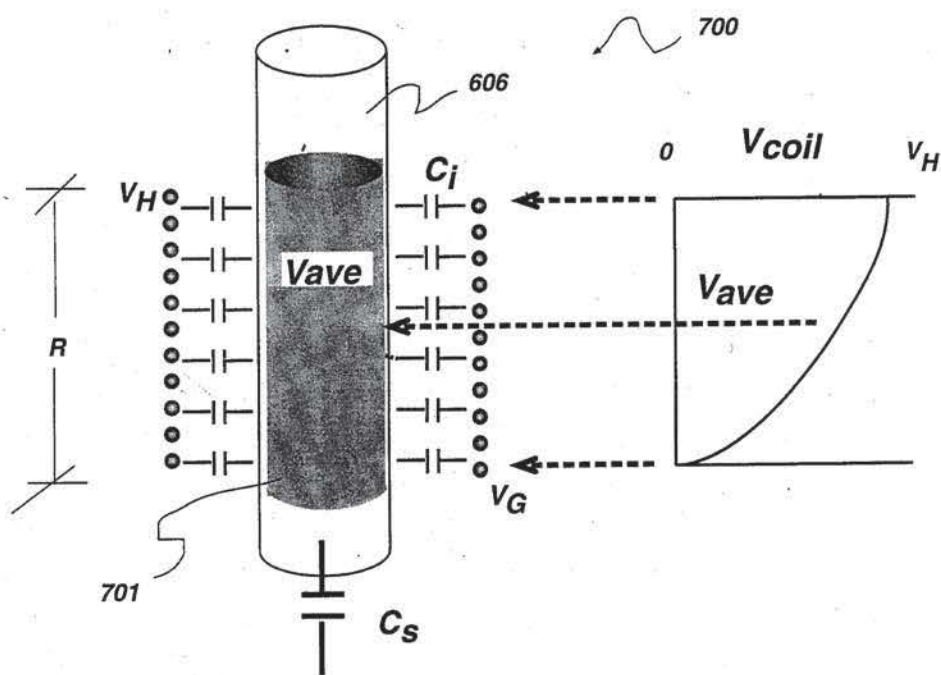

Fig. 7

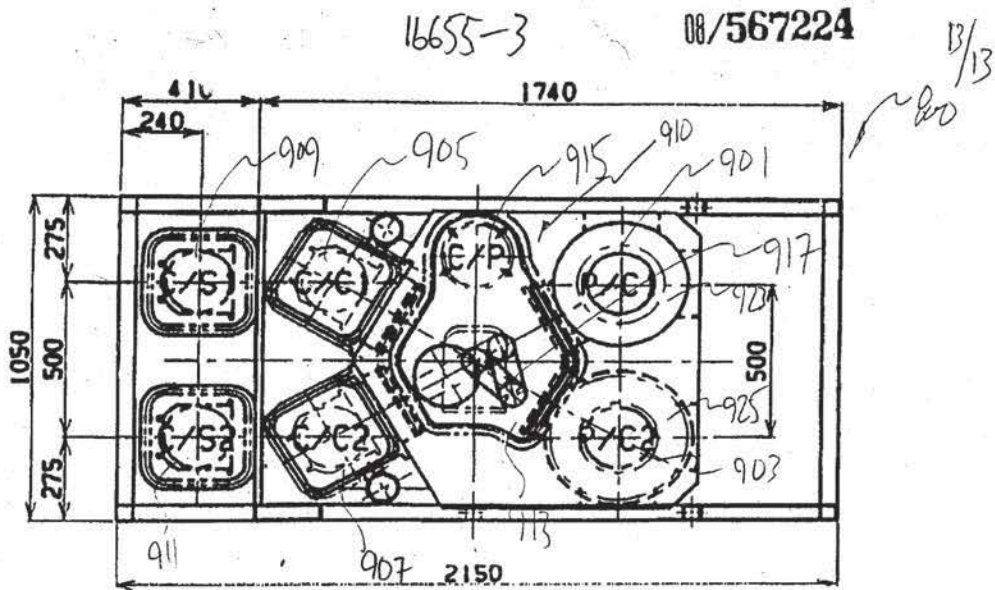

FIG. 8

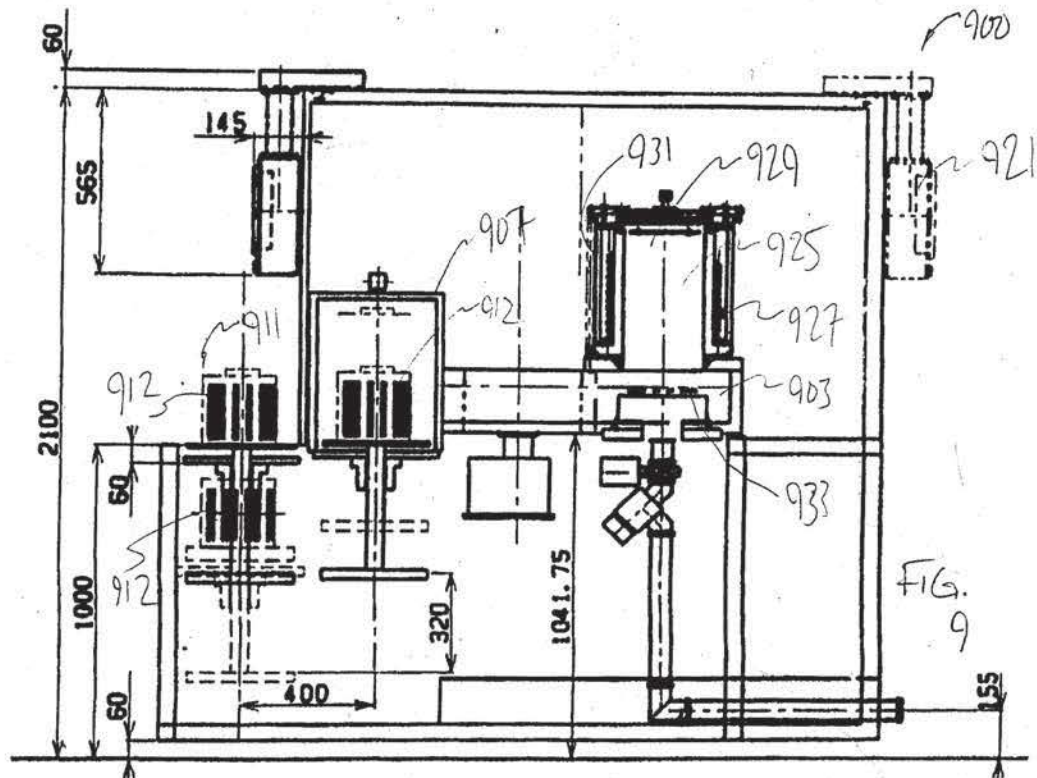

FIG. 9

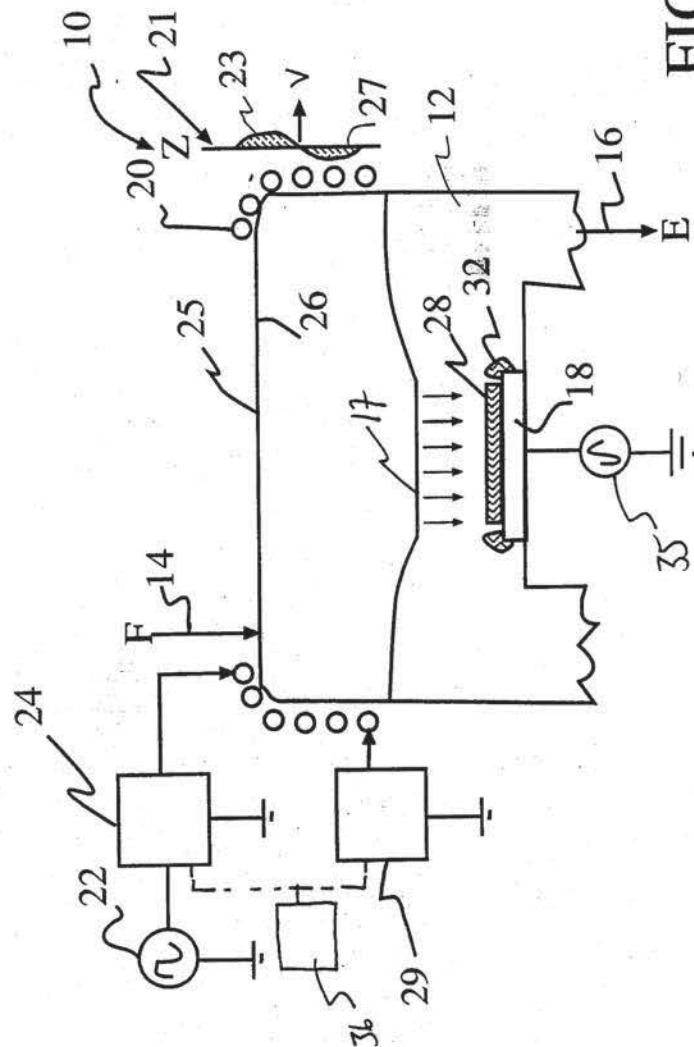

FIG. 1



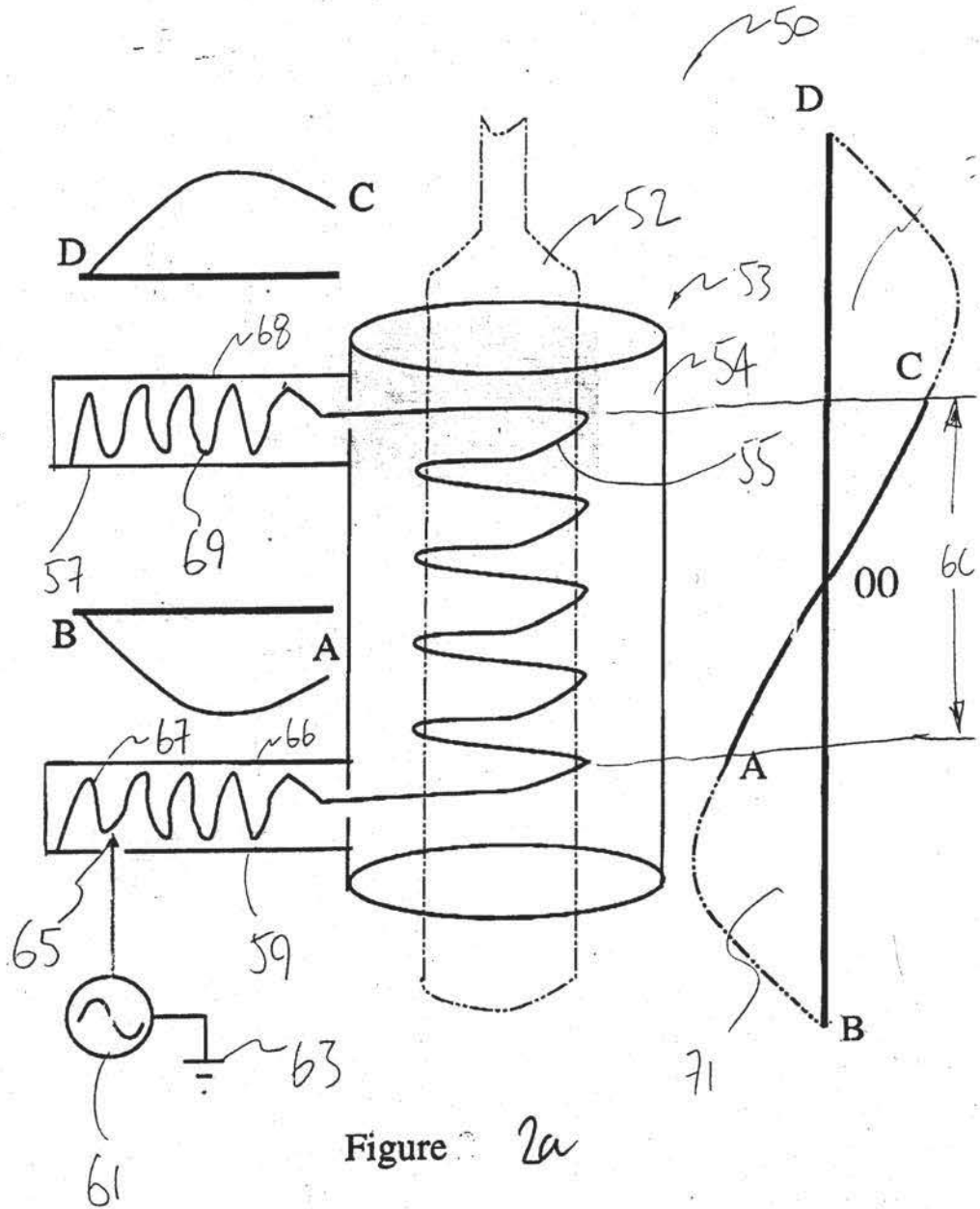

Figure 2a

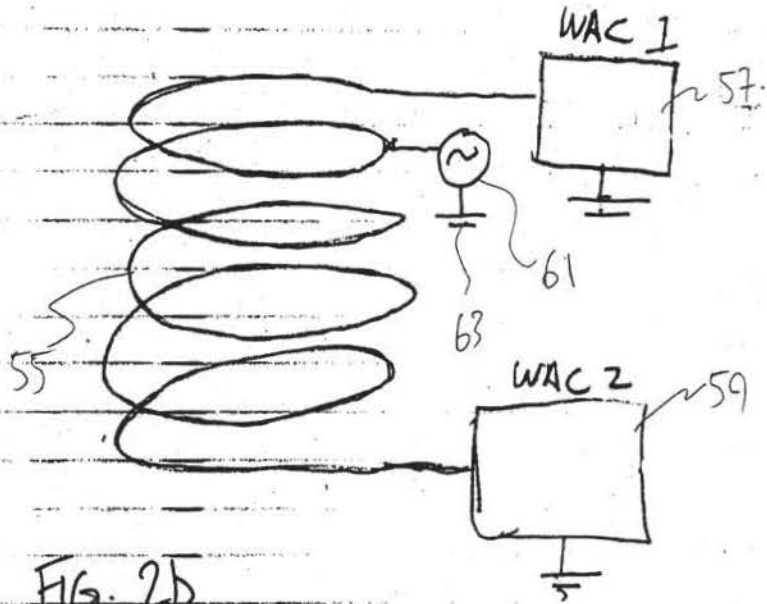

FIG. 2B

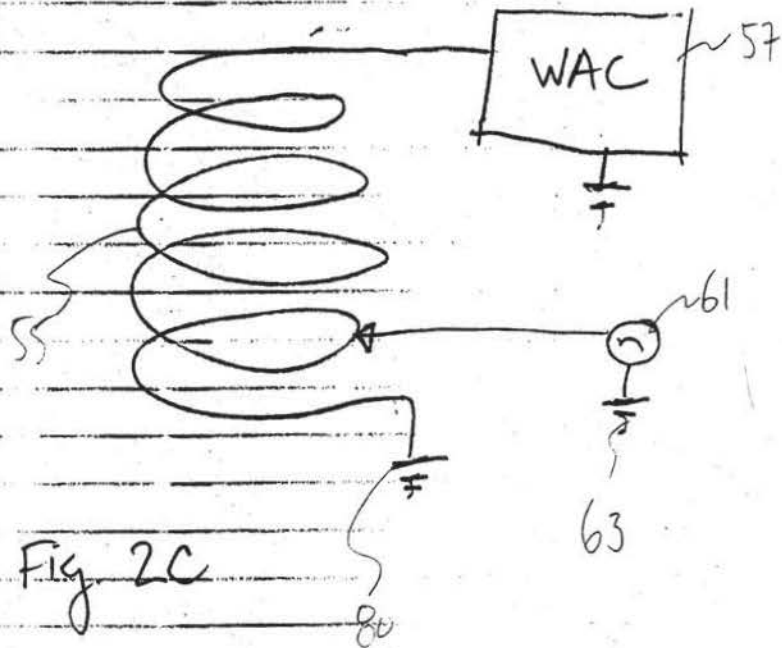

Fig 2C

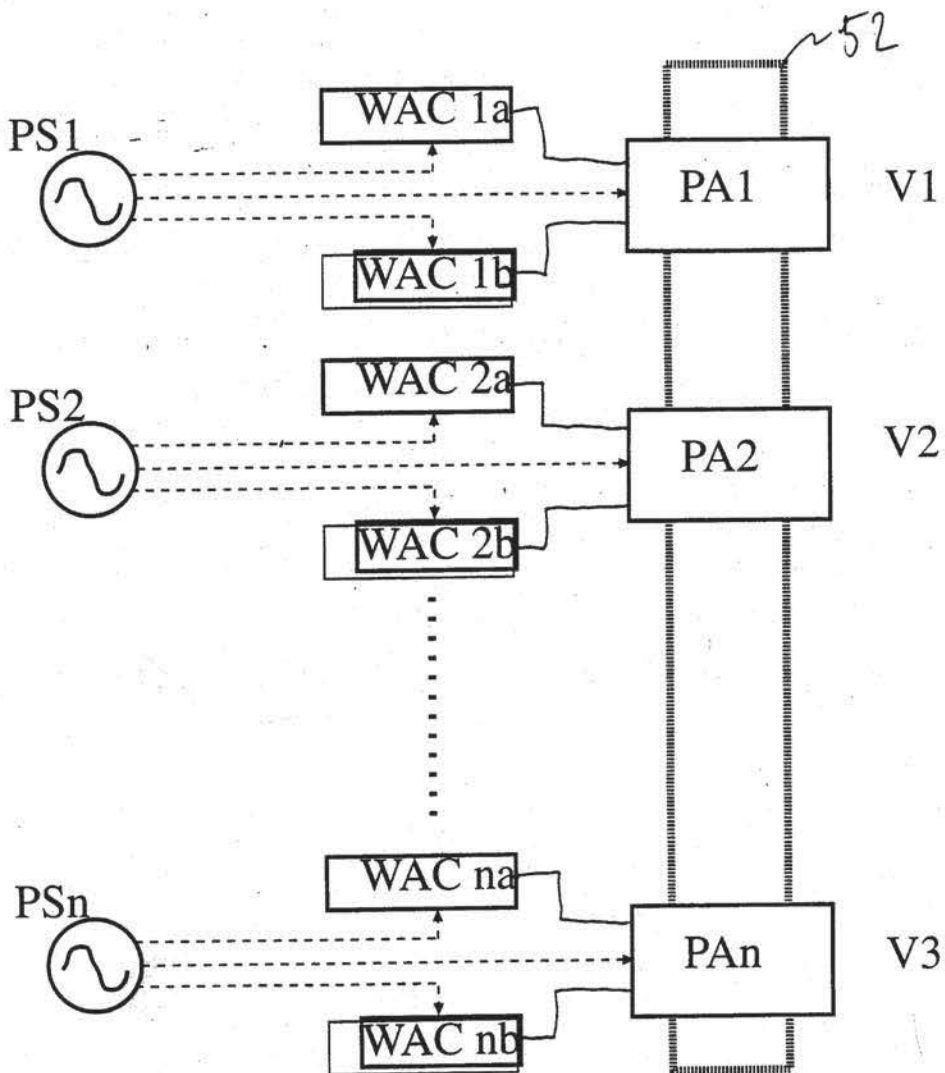

Fig. 2d

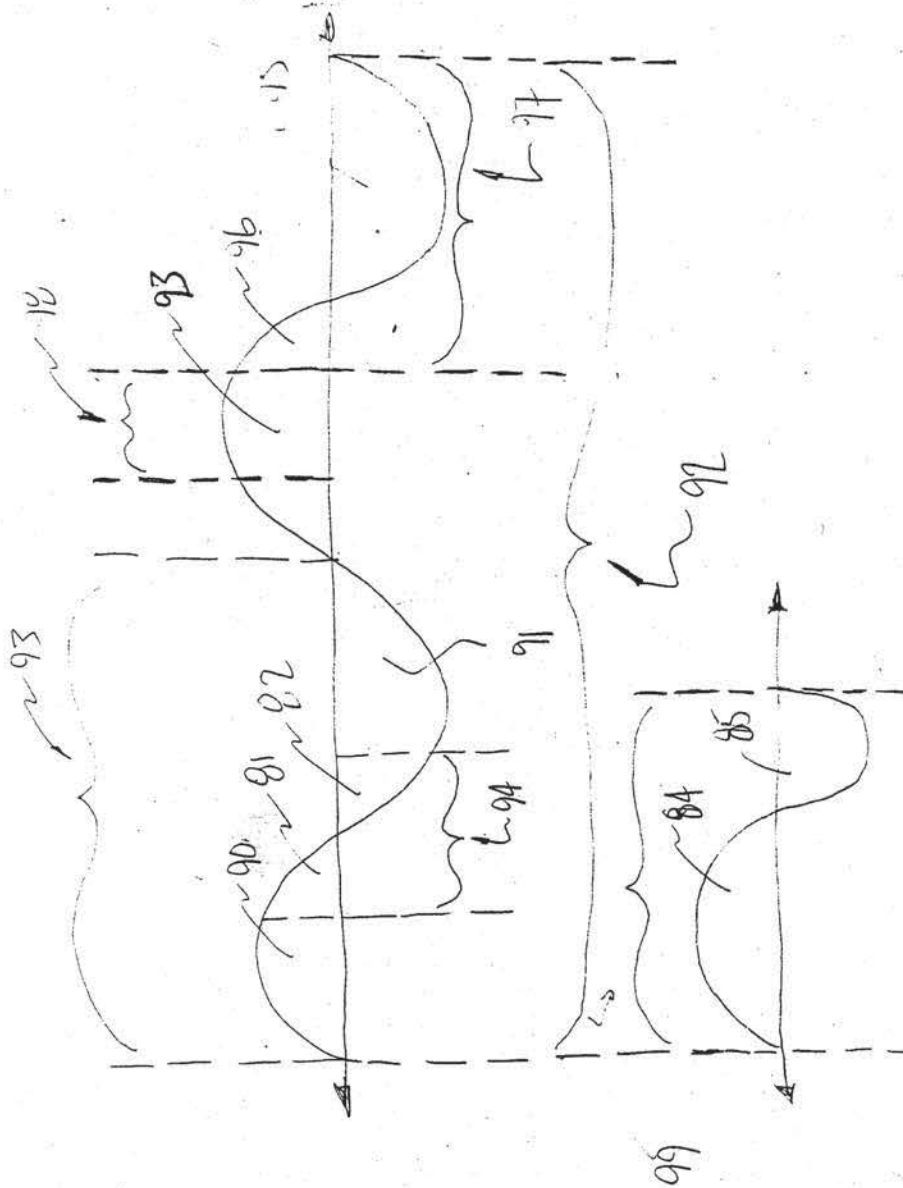

FIG. 2E

PRINT OF DRAWINGS  
AS ORIGINALLY FILED

16655-3

08/567224

6/13

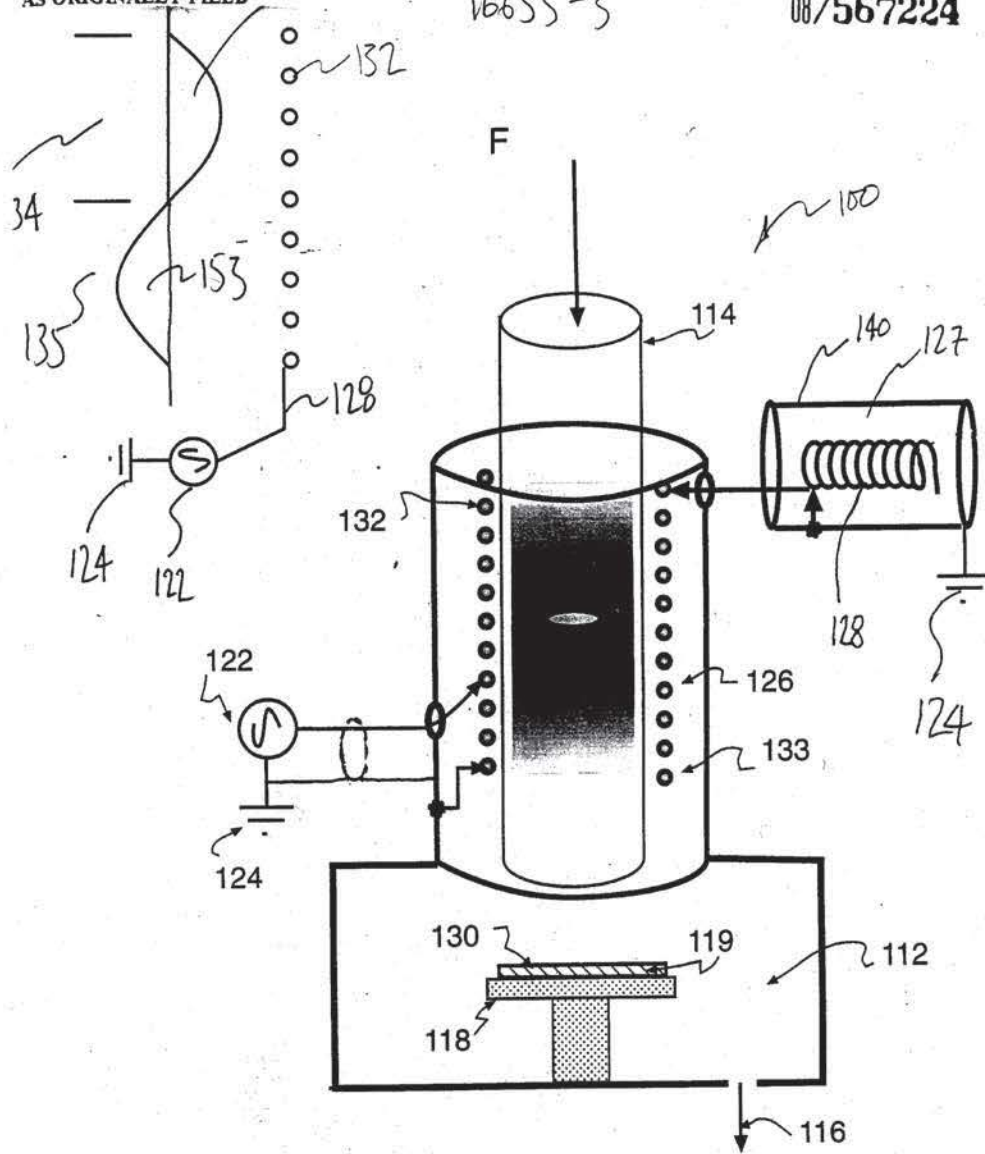

Fig 3

16655-3

08/567224

7/13

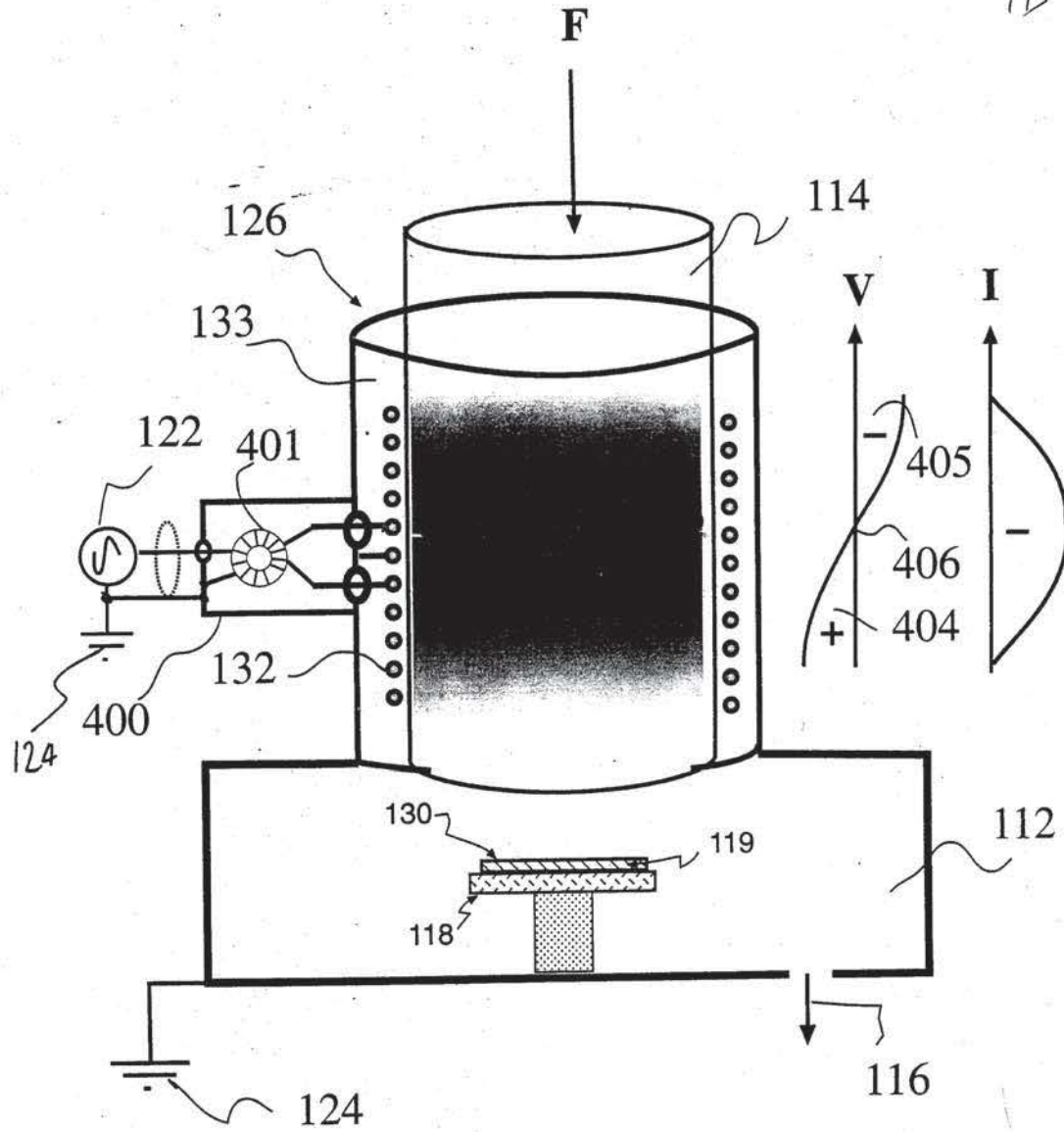

Fig. 4

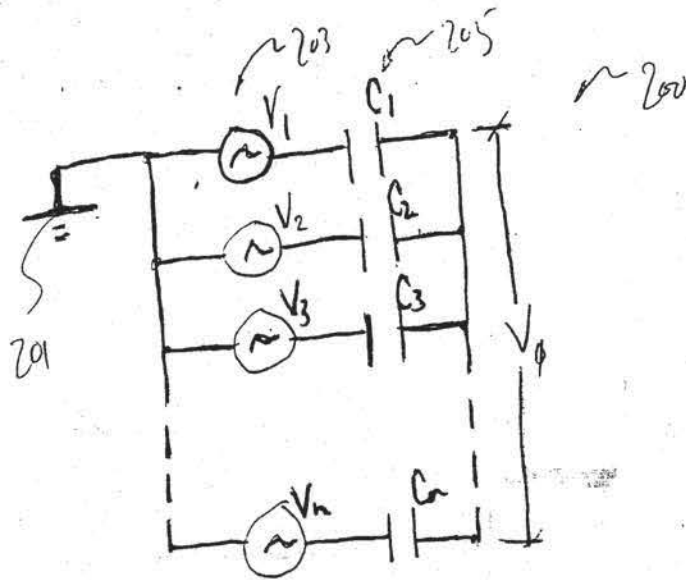

FIG. 5A

16655-3

08/567224

9/13

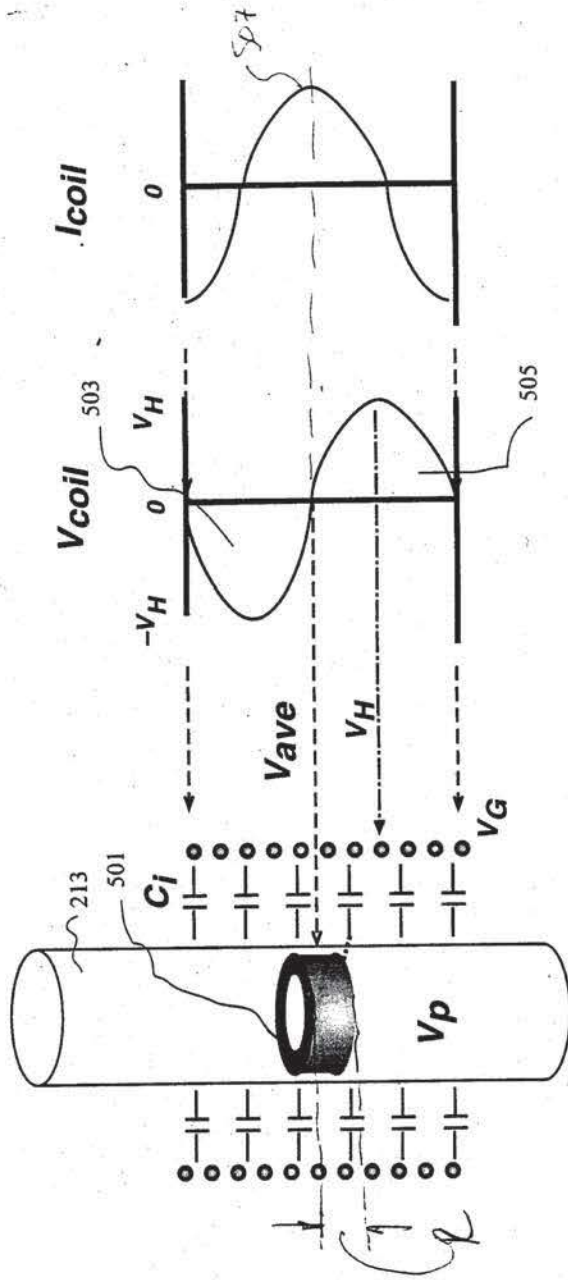

FIG. 5B



PRINT OF DRAWINGS  
AS ORIGINALLY FILED

FUNDAMENTAL STRUCTURE  
OF FULL WAVE LAMBDA HELICAL RESONATOR  
DISCHARGE

16655-3

08/567224

10/13

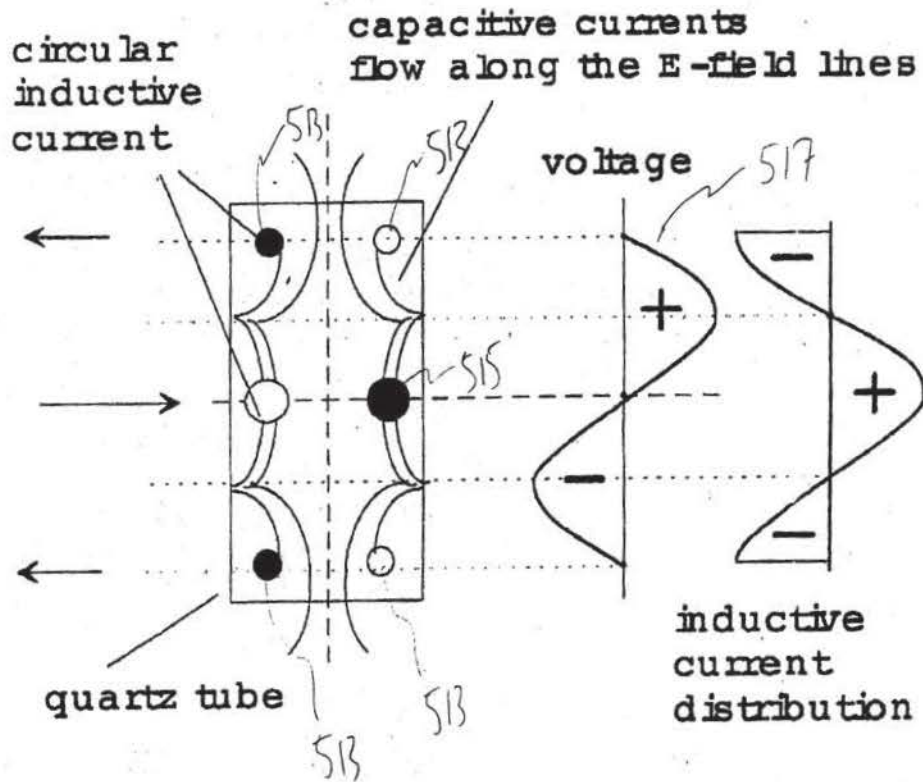

FIG. 5C

16655-3

08/567224

4/13

600

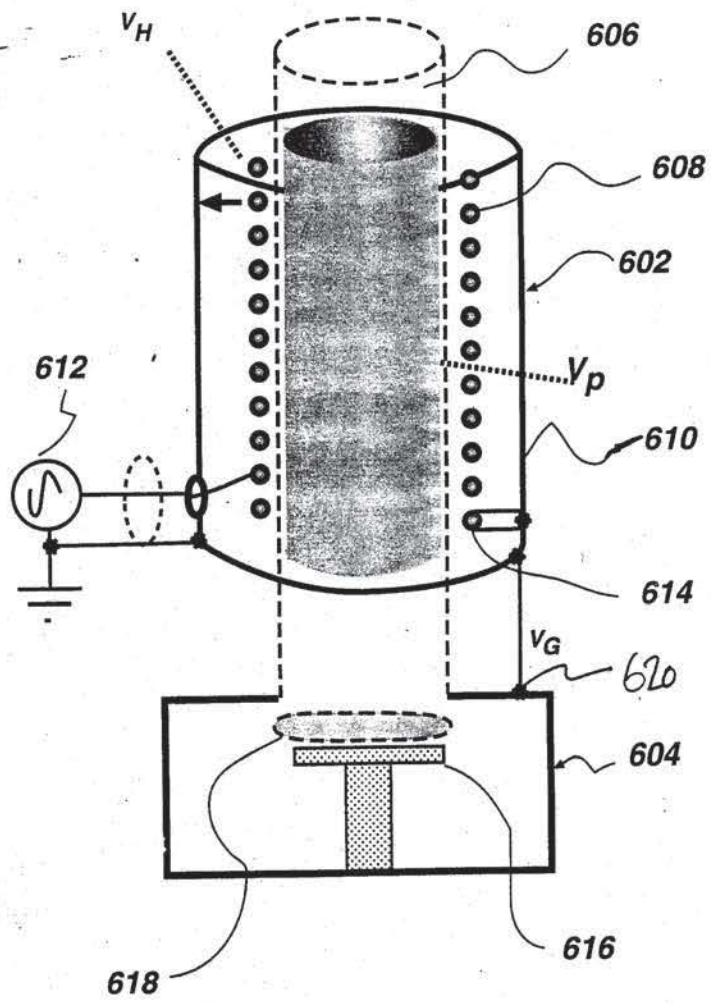

Fig. 6

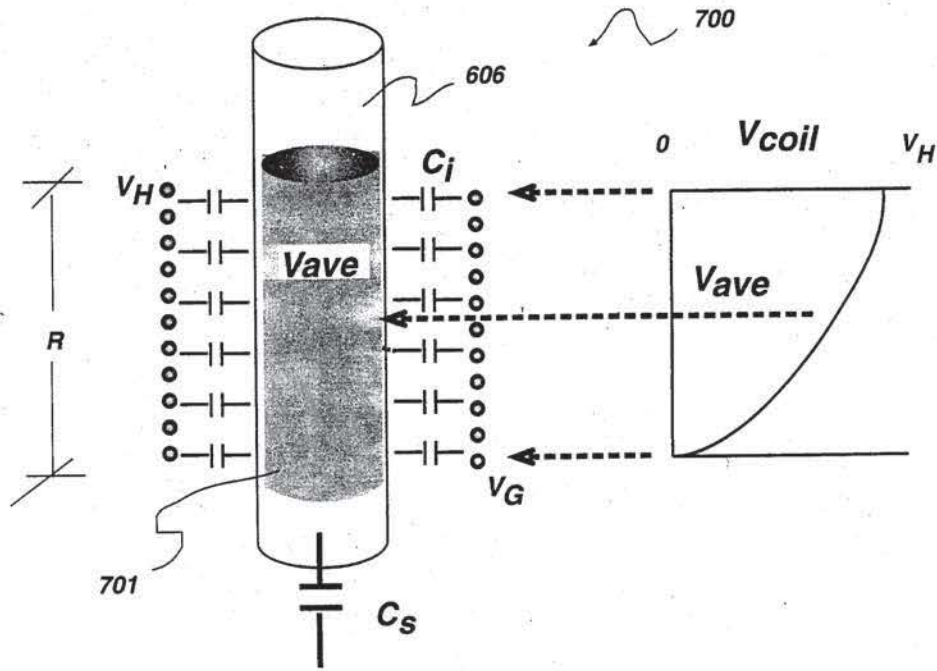

Fig. 7

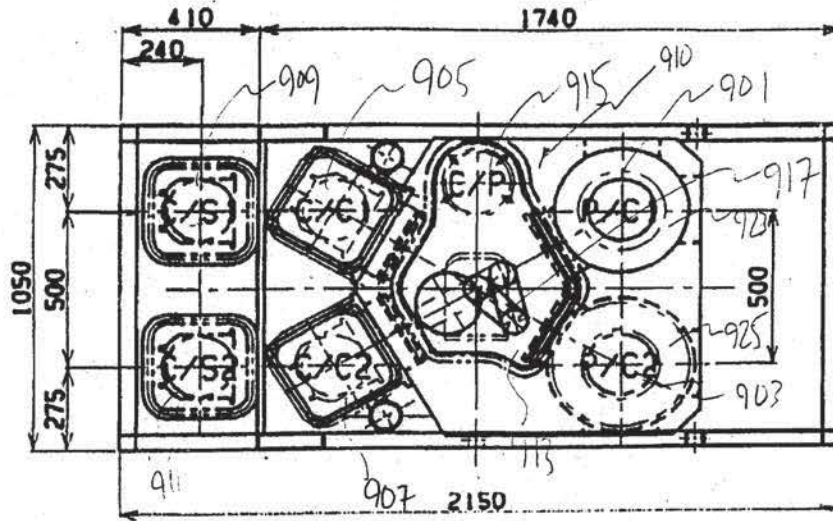

FIG. 8

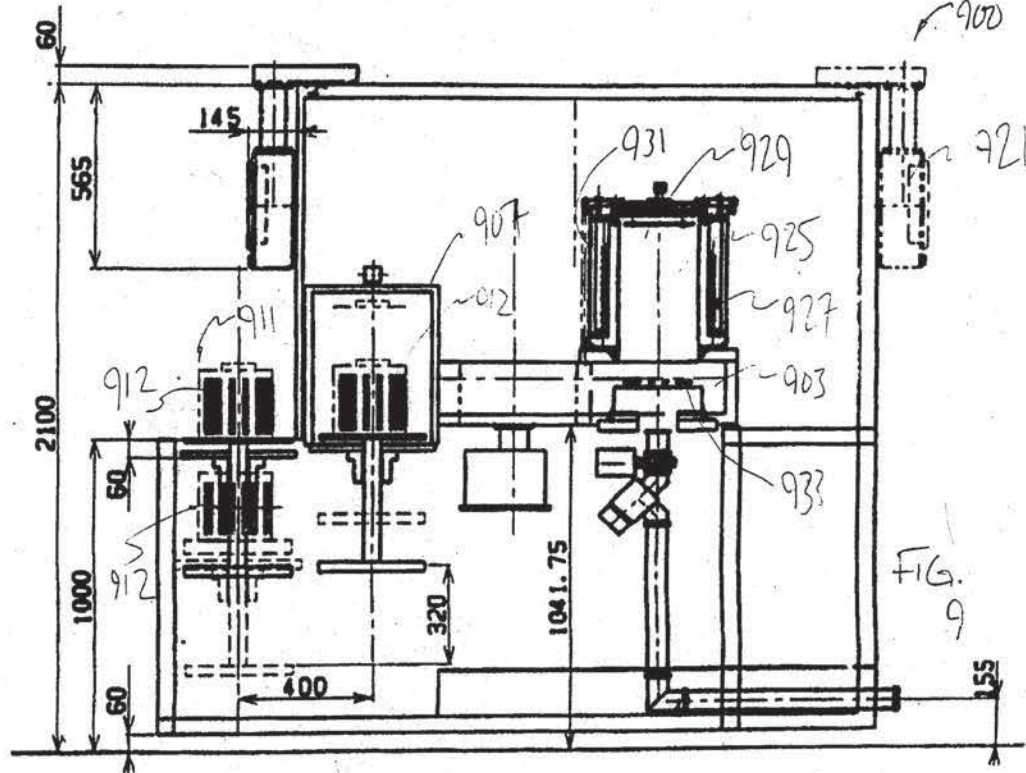

FIG. 9

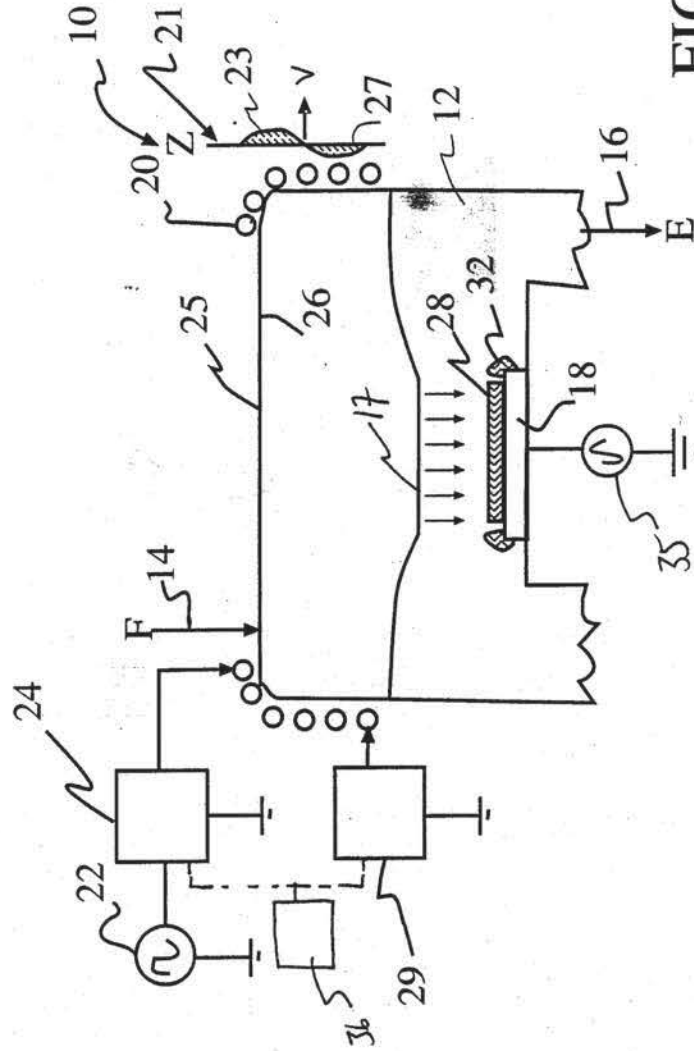

FIG. 1

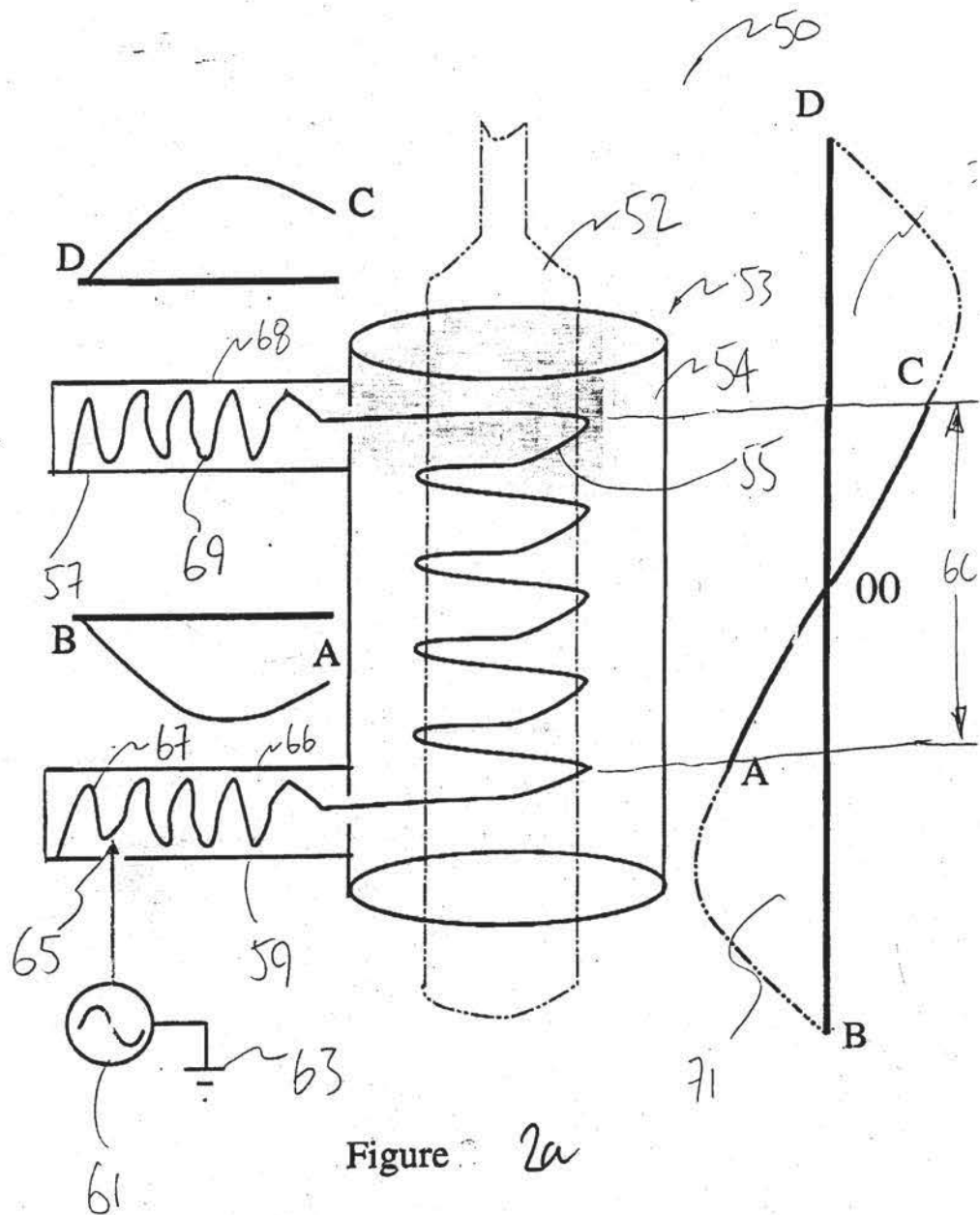

Figure 2a

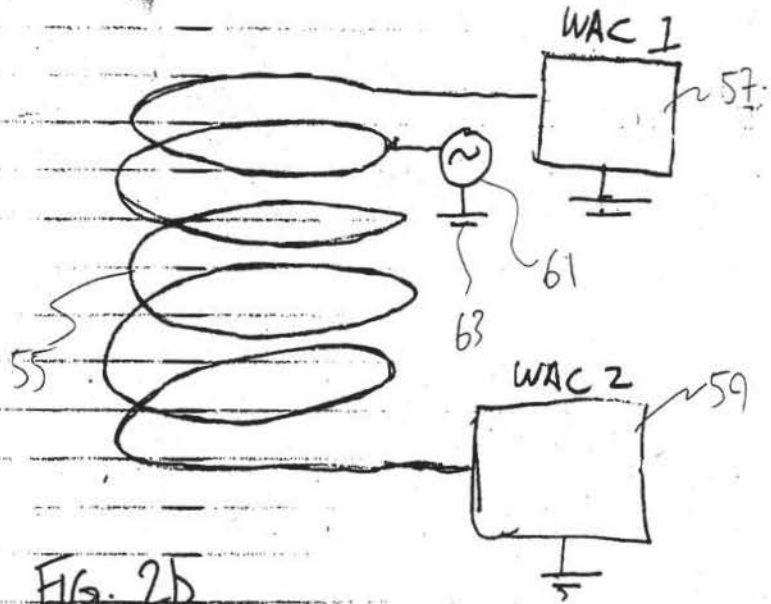

FIG. 2B

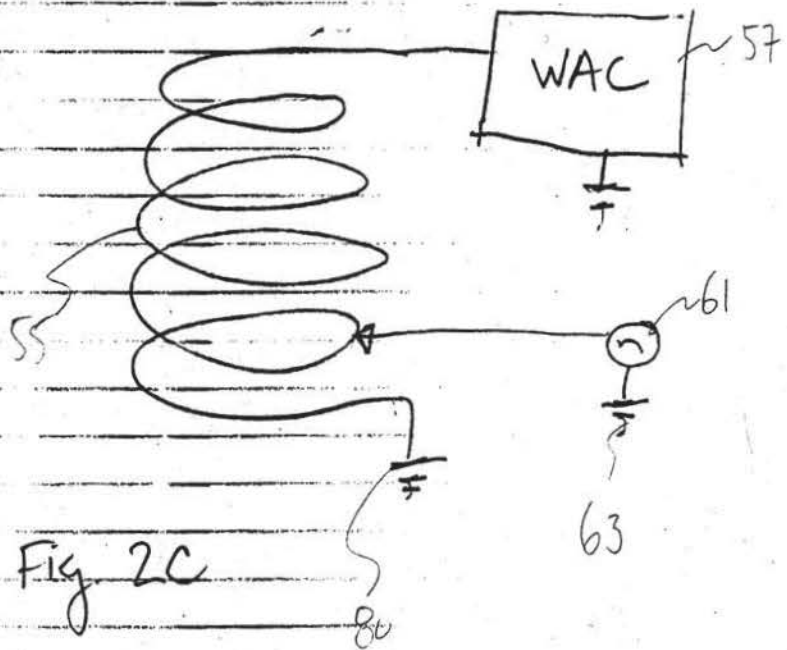

Fig 2C

16655-3

08/567224

4/B

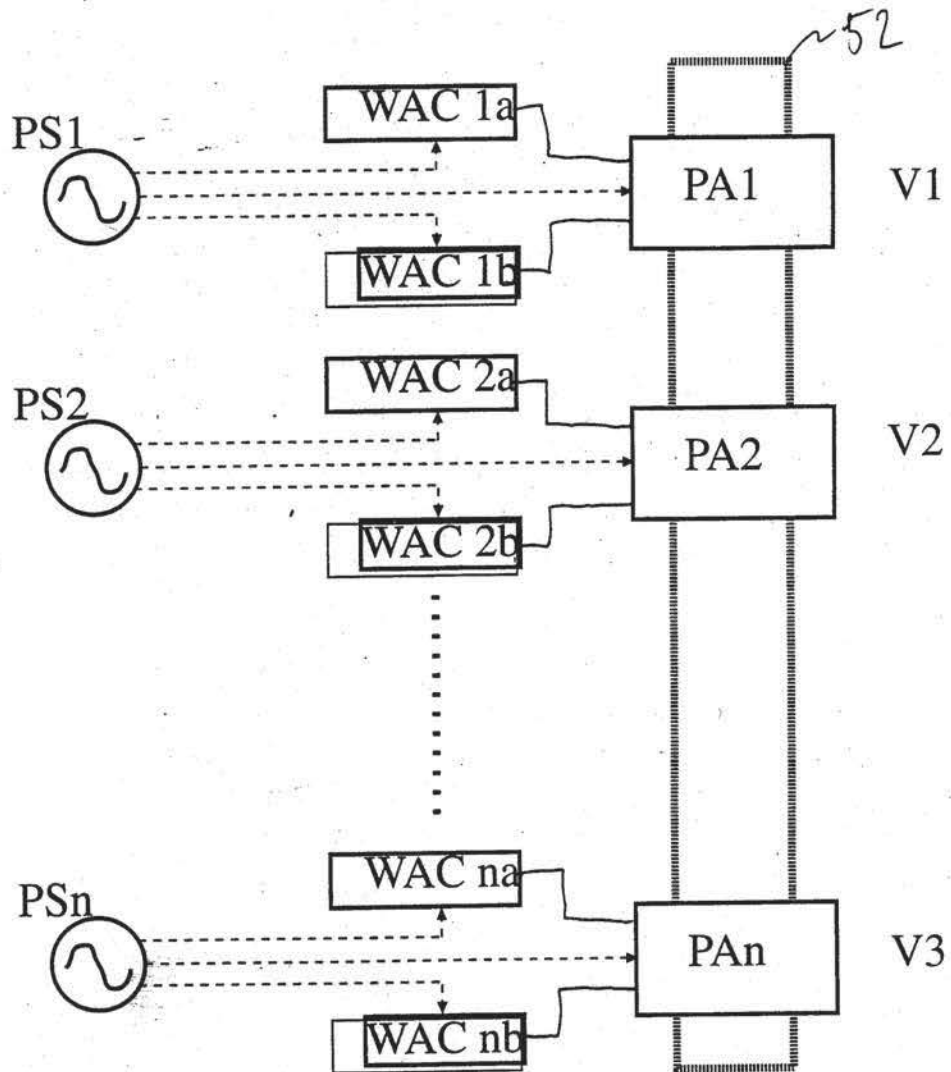

Fig. 2d



16655-3

08/567224

5/3

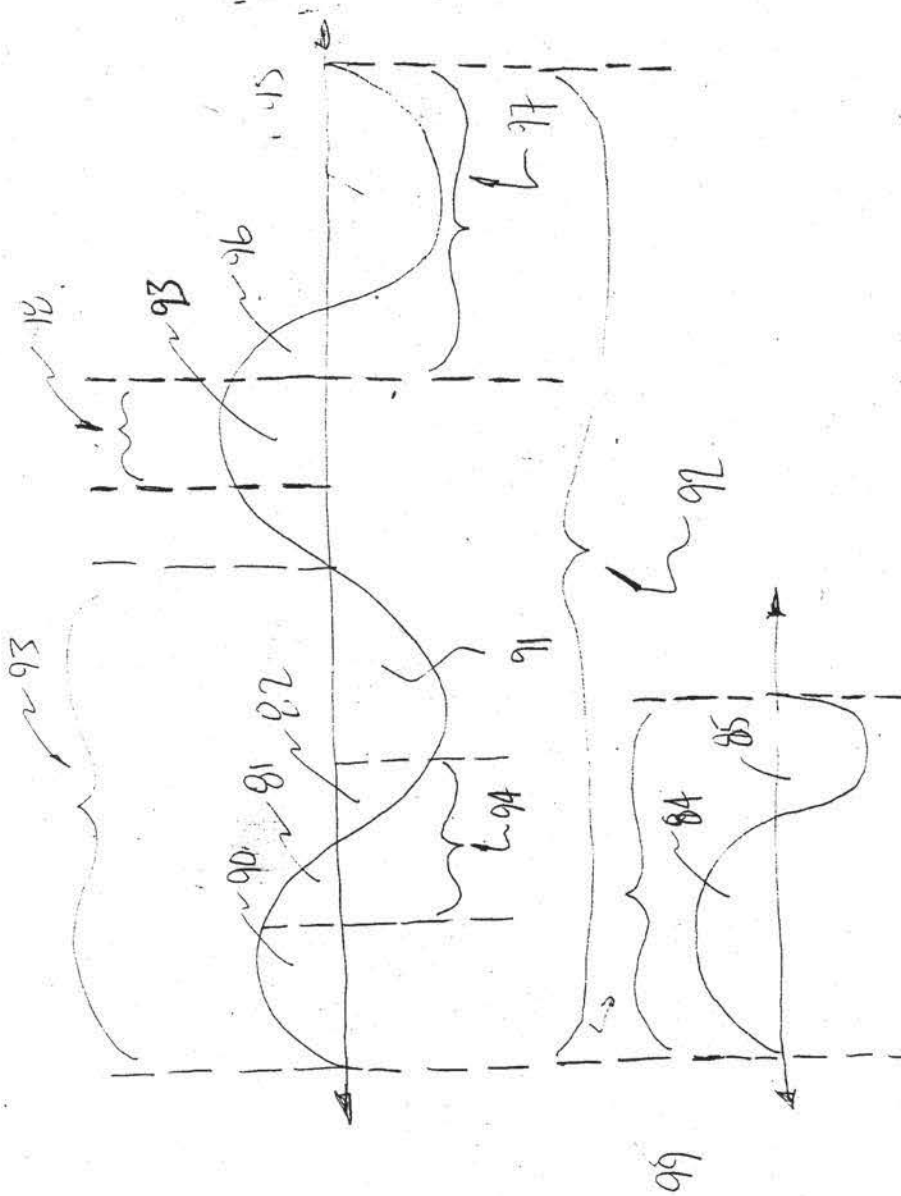

FIG. 2E

PRINT OF DRAWINGS  
AS ORIGINALLY FILED

16655-3

08/567224

6/B

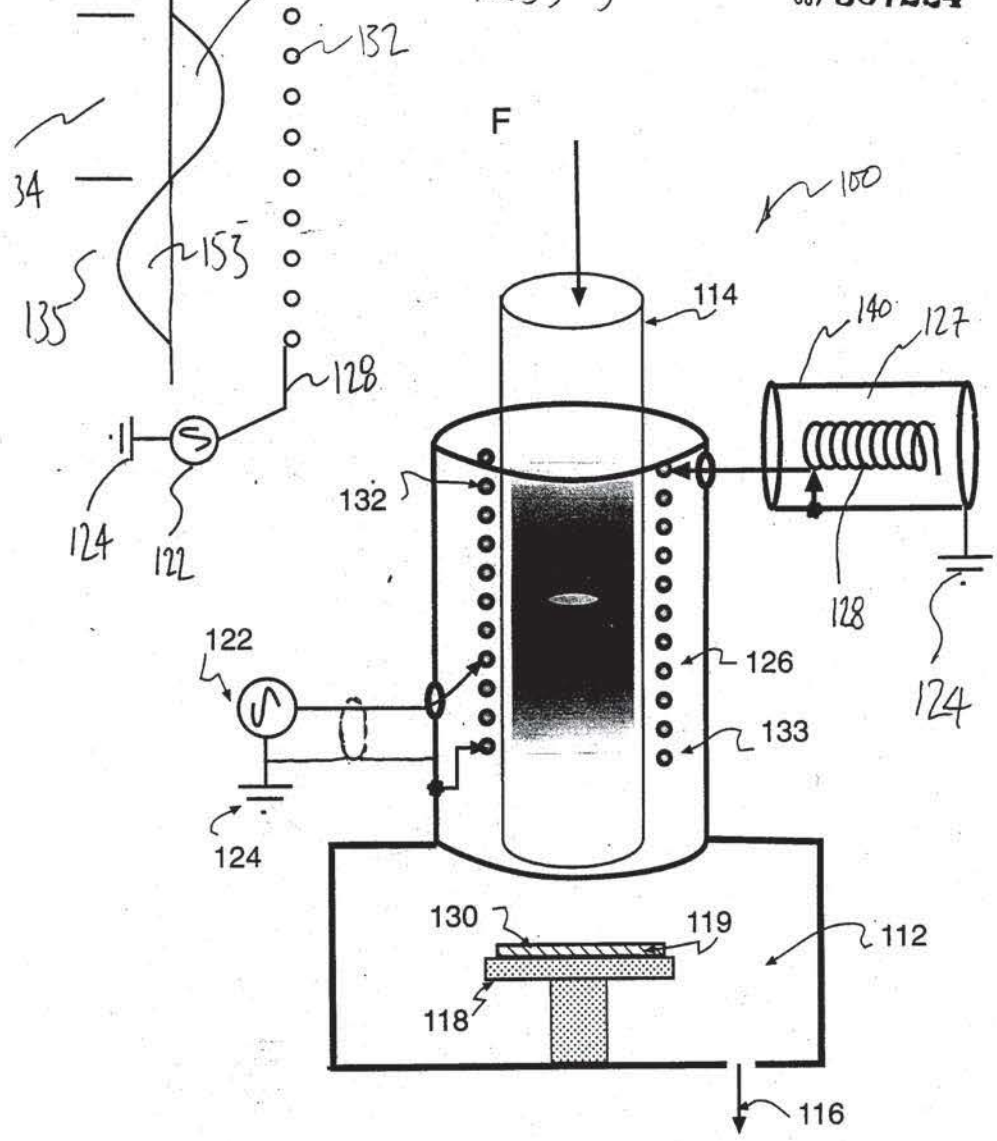

Fig 3

16655-3

08/567224

7/13

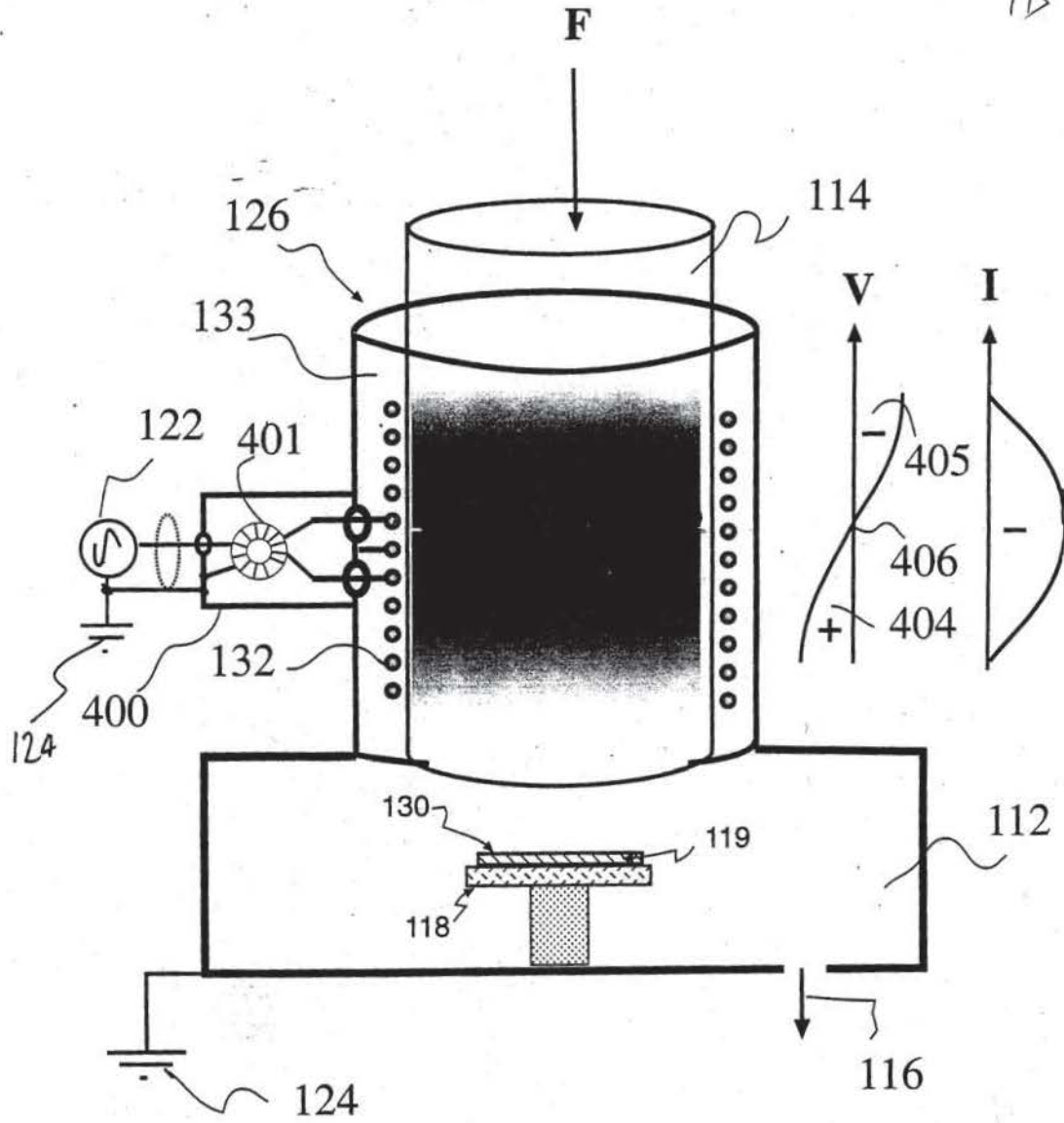

Fig. 4

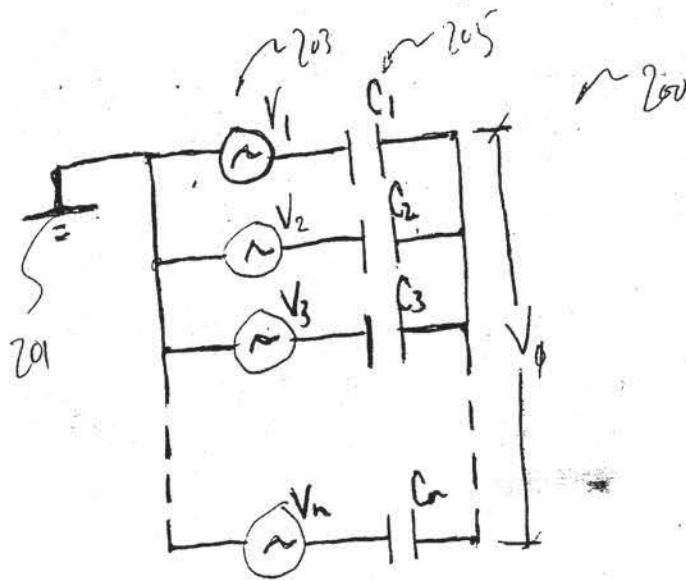

FIG. 5A

16655-3

08/567224

9/13

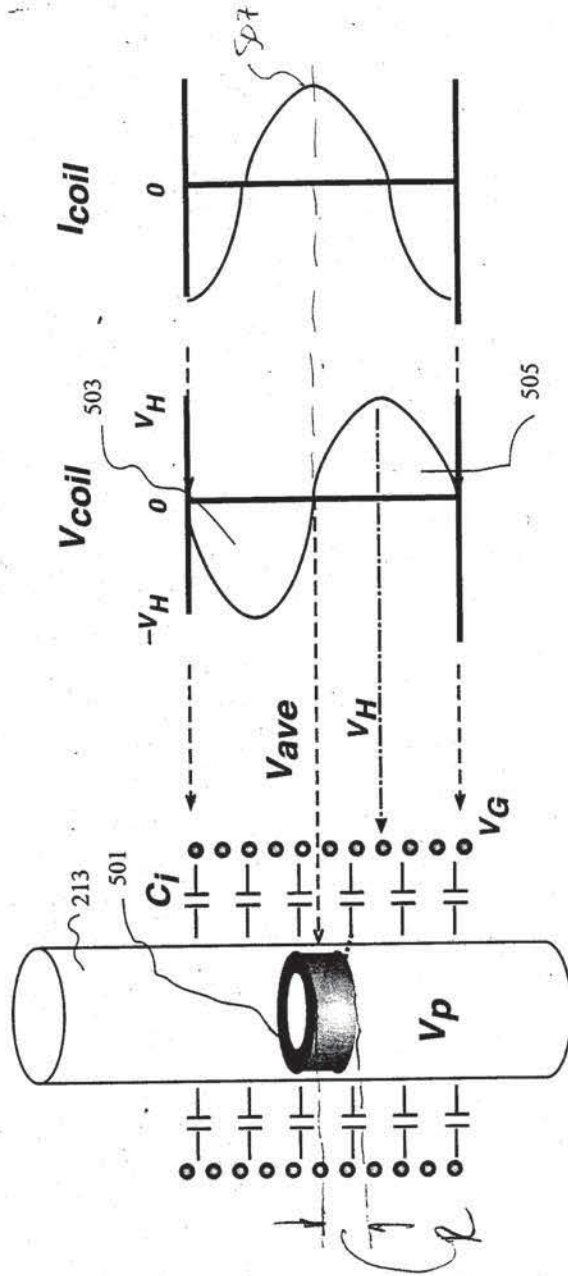

FIG. 5B

PRINT OF DRAWINGS  
AS ORIGINALLY FILED

FUNDAMENTAL STRUCTURE

OF FULL WAVE LAMBDA HELICAL RESONATOR

DISCHARGE

16655-3

08/567224

10/13

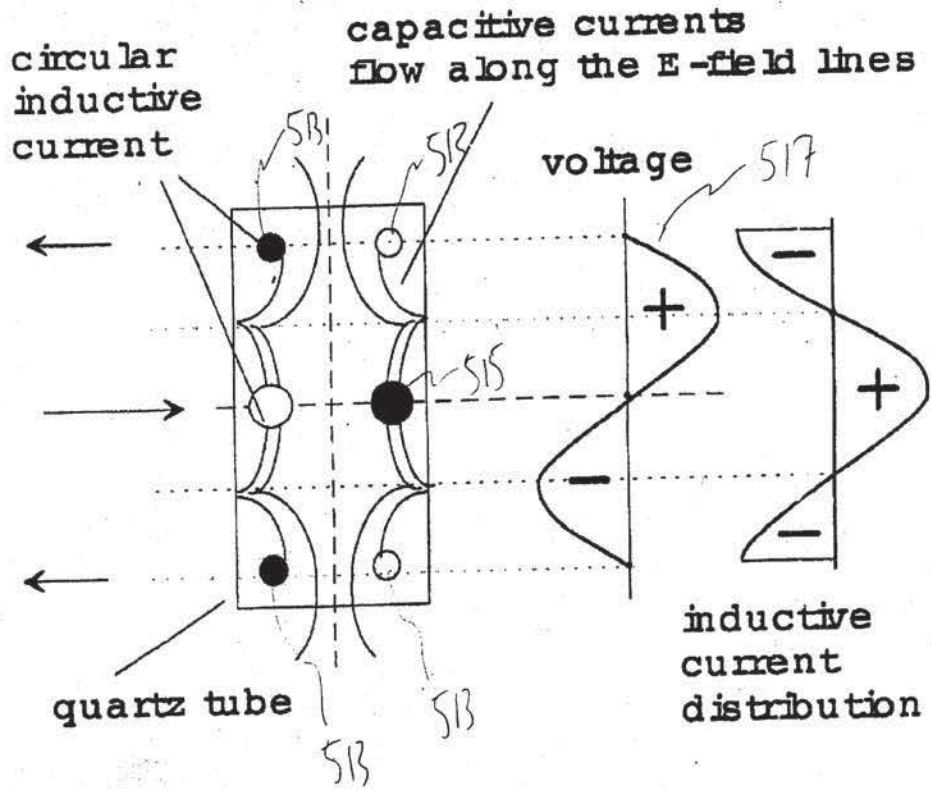

FIG. 5C

16655-3

08/567224

4/13

600

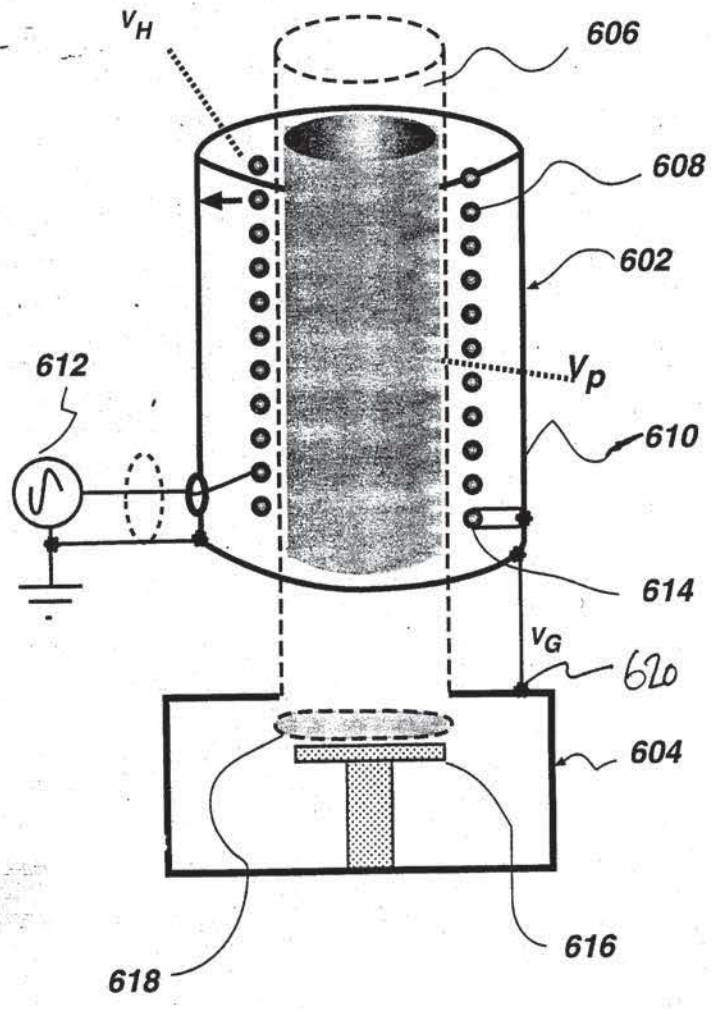

Fig. 6

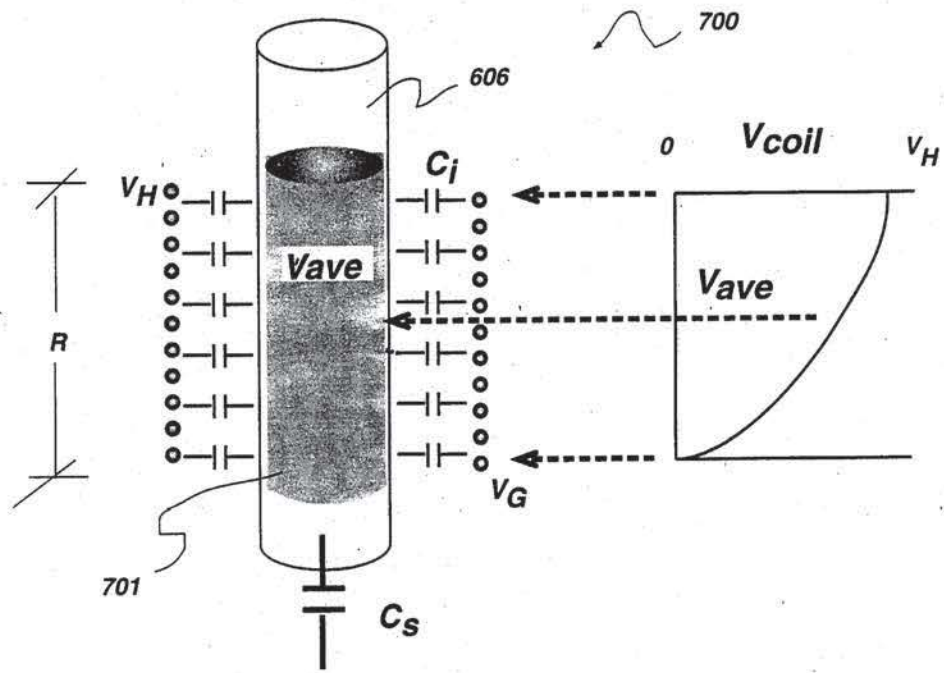

Fig. 7







**UNITED STATES DEPARTMENT OF COMMERCE**  
**Patent and Trademark Office**  
 Address: COMMISSIONER OF PATENTS AND TRADEMARKS  
 Washington, D.C. 20231

APPLICATION NUMBER	FILING DATE	FIRST NAMED APPLICANT	ATTY. DOCKET NO./TITLE
--------------------	-------------	-----------------------	------------------------

08/567,224    12/04/95    FLAMM    D    16655-000300

0232/0214  
 TOWNSEND AND TOWNSEND AND CREW  
 STEUART STREET TOWER  
 ONE MARKET PLAZA  
 SAN FRANCISCO CA 94105

DATE MAILED: 0000

**NOTICE TO FILE MISSING PARTS OF APPLICATION**    02/14/96  
**FILING DATE GRANTED**

An Application Number and Filing Date have been assigned to this application. However, the items indicated below are missing. The required items and fees identified below must be timely submitted **ALONG WITH THE PAYMENT OF A SURCHARGE** for items 1 and 3-6 only of \$ 130 for large entities or \$ 65 for small entities who have filed a verified statement claiming such status. The surcharge is set forth in 37 CFR 1.16(e).

If all required items on this form are filed within the period set below, the total amount owed by applicant as a  large entity,  small entity (verified statement filed), is \$ 180.

Applicant is given **ONE MONTH FROM THE DATE OF THIS LETTER, OR TWO MONTHS FROM THE FILING DATE** of this application, **WHICHEVER IS LATER**, within which to file all required items and pay any fees required above to avoid abandonment. Extensions of time may be obtained by filing a petition accompanied by the extension fee under the provisions of 37 CFR 1.136(a).

1.  The statutory basic filing fee is:  missing     insufficient. Applicant as a  large entity     small entity, must submit \$ 130 to complete the basic filing fee.
2.  Additional claim fees of \$ \_\_\_\_\_ as a  large entity,  small entity, including any required multiple dependent claim fee, are required. Applicant must submit the additional claim fees or cancel the additional claims for which fees are due.
3.  The oath or declaration:
  - is missing.
  - does not cover the newly submitted items.

An oath or declaration in compliance with 37 CFR 1.63, identifying the application by the above Application Number and Filing Date is required.
4.  The oath or declaration does not identify the application to which it applies. An oath or declaration in compliance with 37 CFR 1.63, identifying the application by the above Application Number and Filing Date, is required.
5.  The signature(s) to the oath or declaration is/are:  missing;  by a person other than the inventor or a person qualified under 37 CFR 1.42, 1.43, or 1.47. A properly signed oath or declaration in compliance with 37 CFR 1.63, identifying the application by the above Application Number and Filing Date, is required.
6.  The signature of the following joint inventor(s) is missing from the oath or declaration:
 

\_\_\_\_\_ An oath or declaration listing the names of all inventors and signed by the omitted inventor(s), identifying this application by the above Application Number and Filing Date, is required.
7.  The application was filed in a language other than English. Applicant must file a verified English translation of the application and a fee of \$ \_\_\_\_\_ under 37 CFR 1.17(k), unless this fee has already been paid.
8.  A \$ \_\_\_\_\_ processing fee is required since your check was returned without payment. (37 CFR 1.21(m)).
9.  Your filing receipt was mailed in error because your check was returned without payment.
10.  The application does not comply with the Sequence Rules. See attached Notice to Comply with Sequence Rules 37 CFR 1.821-1.825.
11.  Other.

Direct the response to Box Missing Part and refer any questions to the Customer Service Center at (703) 308-1202.

**A copy of this notice MUST be returned with the response.**

OFFICE COPY



I hereby certify that this correspondence is being deposited with the United States Postal Service as first class mail in an envelope addressed to: Assistant Commissioner for Patents, Attn: Box Missing Parts, Washington, D.C. 20231,

PATENT

Attorney Docket No. 16655-000300

on June 3, 1996  
TOWNSEND and TOWNSEND and CREW LLP

By Deane Elzingre

IN THE UNITED STATES PATENT AND TRADEMARK OFFICE

In re application of:	)	
	)	
Daniel L. Flamm, et al.	)	Examiner: Unassigned
	)	
Serial No.: 08/567,224	)	Art Unit: Unassigned
	)	
Filed: December 4, 1995	)	TRANSMITTAL LETTER - RESPONSE
	)	TO NOTICE OF MISSING PARTS
For: PROCESS DEPENDING ON	)	
PLASMA DISCHARGES	)	
SUSTAINED BY INDUCTIVE	)	
COUPLING	)	

Attn: Box Missing Parts  
Assistant Commissioner for Patents  
Washington, D.C. 20231

Sir:

Pursuant to the Notice to File Missing Parts of Application - Filing Date  
Granted dated February 14, 1996, enclosed are the following to be made of record in the  
above-identified application:

- 1) Petition to Extend Time Under 37 CFR §1.136(a)
- 2) Executed Declaration and Power of Attorney;
- 3) Copy of Notice of Missing Parts;
- 4) Postcard.

Please charge Deposit Account No. 20-1430 for the following fees:

(a) Filing Fee (§ 1.16(a))(Large Entity)	\$ 750.00
(b) Excess Claims Fees (§ 1.16(b), (c)):	
<u>20</u> - 20 = <u>0</u> x 22.00 =	\$ 0.00
<u>3</u> - 3 = <u>0</u> x 78.00 =	\$ 0.00
(c) Missing Parts Surcharge (§1.16(e))	\$ 130.00
<b>TOTAL FEES TO BE CHARGED</b>	<b>\$ 880.00</b>

Daniel L. Flamm, et al.  
Serial No.: 08/567,224  
Page 2

PATENT

The Commissioner is hereby authorized to charge any additional fees associated with this paper or during the pendency of this application, or credit any overpayment to Deposit Account No. 20-1430 for this paper and during the prosecution of this application. This Transmittal Letter is submitted in triplicate.

Respectfully submitted,

Dated: 6/1/96

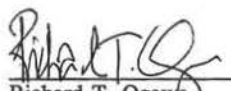
  
Richard T. Ogawa  
Reg. No. 37,692

TOWNSEND and TOWNSEND and CREW LLP  
Two Embarcadero Center, 8th Floor  
San Francisco, California 94111-3834  
(415) 326-2400  
Fax (415) 326-2422  
RTO:de

rto\work\16655\3-mp.res



I hereby certify that this correspondence is being deposited with the United States Postal Service as first class mail in an envelope addressed to: Assistant Commissioner for Patents, Attn: Box Missing Parts, Washington, D.C. 20231,

PATENT

Attorney Docket No. 16655-000300

June 3, 1996  
TOWNSEND and TOWNSEND and CREW LLP

By Deane Elgenre

IN THE UNITED STATES PATENT AND TRADEMARK OFFICE

In re application of:	)	
	)	
Daniel L. Flamm, et al.	)	Examiner: Unassigned
	)	
Serial No.: 08/567,224	)	Art Unit: Unassigned
	)	
Filed: December 4, 1995	)	TRANSMITTAL LETTER - RESPONSE
	)	TO NOTICE OF MISSING PARTS
For: PROCESS DEPENDING ON	)	
PLASMA DISCHARGES	)	
SUSTAINED BY INDUCTIVE	)	
COUPLING	)	

Attn: Box Missing Parts  
Assistant Commissioner for Patents  
Washington, D.C. 20231

Sir:

Pursuant to the Notice to File Missing Parts of Application - Filing Date  
Granted dated February 14, 1996, enclosed are the following to be made of record in the  
above-identified application:

- 1) Petition to Extend Time Under 37 CFR §1.136(a)
- 2) Executed Declaration and Power of Attorney;
- 3) Copy of Notice of Missing Parts;
- 4) Postcard.

Please charge Deposit Account No. 20-1430 for the following fees:

(a) Filing Fee (§ 1.16(a))(Large Entity)	\$ 750.00
(b) Excess Claims Fees (§ 1.16(b), (c)):	
<u>20</u> - 20 = <u>0</u> x 22.00 =	\$ 0.00
<u>3</u> - 3 = <u>0</u> x 78.00 =	\$ 0.00
(c) Missing Parts Surcharge (§1.16(e))	\$ 130.00
<b>TOTAL FEES TO BE CHARGED</b>	<b>\$ 880.00</b>

Daniel L. Flamm, et al.  
Serial No.: 08/567,224  
Page 2

PATENT

The Commissioner is hereby authorized to charge any additional fees associated with this paper or during the pendency of this application, or credit any overpayment to Deposit Account No. 20-1430 for this paper and during the prosecution of this application. This Transmittal Letter is submitted in triplicate.

Respectfully submitted,

Dated: \_\_\_\_\_

6/1/98

  
Richard T. Ogawa  
Reg. No. 37,692

TOWNSEND and TOWNSEND and CREW LLP  
Two Embarcadero Center, 8th Floor  
San Francisco, California 94111-3834  
(415) 326-2400  
Fax (415) 326-2422  
RTO:de

rto\work\16655\3-mp.res



*10e 030*

UNITED STATES DEPARTMENT OF COMMERCE  
 Patent and Trademark Office  
 Address: COMMISSIONER OF PATENTS AND TRADEMARKS  
 Washington, D.C. 20231

APPLICATION NUMBER	FILING DATE	FIRST NAMED APPLICANT	ATTY. DOCKET NO./TITLE
--------------------	-------------	-----------------------	------------------------

08/567,224    12/04/95    FLAMM    D    16655-000300

0232/0214  
 TOWNSEND AND TOWNSEND AND CREW  
 STEUART STREET TOWER  
 ONE MARKET PLAZA  
 SAN FRANCISCO CA 94105

DATE MAILED: 0000

**NOTICE TO FILE MISSING PARTS OF APPLICATION**    02/14/96  
**FILING DATE GRANTED**

An Application Number and Filing Date have been assigned to this application. However, the items indicated below are missing. The required items and fees identified below must be timely submitted **ALONG WITH THE PAYMENT OF A SURCHARGE** for items 1 and 3-6 only of \$ 130 for large entities or \$ 65 for small entities who have filed a verified statement claiming such status. The surcharge is set forth in 37 CFR 1.16(e).

If all required items on this form are filed within the period set below, the total amount owed by applicant as a  large entity,  small entity (verified statement filed), is \$ 130.

Applicant is given **ONE MONTH FROM THE DATE OF THIS LETTER, OR TWO MONTHS FROM THE FILING DATE** of this application, **WHICHEVER IS LATER**, within which to file all required items and pay any fees required above to avoid abandonment. Extensions of time may be obtained by filing a petition accompanied by the extension fee under the provisions of 37 CFR 1.136(a).

1.  The statutory basic filing fee is:  missing     insufficient. Applicant as a  large entity     small entity, must submit \$ 130 to complete the basic filing fee.
2.  Additional claim fees of \$ \_\_\_\_\_ as a  large entity,  small entity, including any required multiple dependent claim fee, are required. Applicant must submit the additional claim fees or cancel the additional claims for which fees are due.
3.  The oath or declaration:
  - is missing.
  - does not cover the newly submitted items.

An oath or declaration in compliance with 37 CFR 1.63, identifying the application by the above Application Number and Filing Date is required.
4.  The oath or declaration does not identify the application to which it applies. An oath or declaration in compliance with 37 CFR 1.63, identifying the application by the above Application Number and Filing Date, is required.
5.  The signature(s) to the oath or declaration is/are:  missing;  by a person other than the inventor or a person qualified under 37 CFR 1.42, 1.43, or 1.47. A properly signed oath or declaration in compliance with 37 CFR 1.63, identifying the application by the above Application Number and Filing Date, is required.
6.  The signature of the following joint inventor(s) is missing from the oath or declaration:
 

\_\_\_\_\_ An oath or declaration listing the names of all inventors and signed by the omitted inventor(s), identifying this application by the above Application Number and Filing Date, is required.
7.  The application was filed in a language other than English. Applicant must file a verified English translation of the application and a fee of \$ \_\_\_\_\_ under 37 CFR 1.17(k), unless this fee has already been paid.
8.  A \$ \_\_\_\_\_ processing fee is required since your check was returned without payment. (37 CFR 1.21(m)).
9.  Your filing receipt was mailed in error because your check was returned without payment.
10.  The application does not comply with the Sequence Rules. See attached Notice to Comply with Sequence Rules 37 CFR 1.821-1.825.
11.  Other.

Direct the response to Box Missing Part and refer any questions to the Customer Service Center at (703) 308-1202.

**A copy of this notice MUST be returned with the response.**

**DECLARATION AND POWER OF ATTORNEY**

As a below named inventor, I declare that:

My residence, post office address and citizenship are as stated below next to my name; I believe I am the original, first and sole inventor (if only one name is listed below) or an original, first and joint inventor (if plural inventors are named below) of the subject matter which is claimed and for which a patent is sought on the invention entitled: **PROCESS DEPENDING ON PLASMA DISCHARGES SUSTAINED BY INDUCTIVE COUPLING** the specification of which \_\_\_ is attached hereto or **X** was filed on **December 4, 1995** as Application Serial No. **08/567,224** and was amended on \_\_\_\_\_ (if applicable).

I have reviewed and understand the contents of the above identified specification, including the claims, as amended by any amendment referred to above. I acknowledge the duty to disclose information which is material to the examination of this application in accordance with Title 37, Code of Federal Regulations, Section 1.56. I claim foreign priority benefits under Title 35, United States Code, Section 119 of any foreign application(s) for patent or inventor's certificate listed below and have also identified below any foreign application for patent or inventor's certificate having a filing date before that of the application on which priority is claimed.

**Prior Foreign Application(s)**

Country	Application No.	Date of Filing	Priority Claimed Under 35 USC 119
			Yes ___ No ___
			Yes ___ No ___

I claim the benefit under Title 35, United States Code, Section 120 of any United States application(s) listed below and, insofar as the subject matter of each of the claims of this application is not disclosed in the prior United States application in the manner provided by the first paragraph of Title 35, United States Code, Section 112, I acknowledge the duty to disclose material information as defined in Title 37, Code of Federal Regulations, Section 1.56 which occurred between the filing date of the prior application and the national or PCT international filing date of this application:

Application Serial No.	Date of Filing	Status
		___ Patented ___ Pending ___ Abandoned
		___ Patented ___ Pending ___ Abandoned

**POWER OF ATTORNEY:** As a named inventor, I hereby appoint the following attorney(s) and/or agent(s) to prosecute this application and transact all business in the Patent and Trademark Office connected therewith.

3

Richard T. Ogawa, Reg. No. 37,692  
 William J. Bohler, Reg. No. 31,487  
 Kenneth R. Allen, Reg. No. 27,301

Send Correspondence to: <u>Richard T. Ogawa</u> <u>TOWNSEND and TOWNSEND AND CREW LLP</u> <u>Two Embarcadero Center, 8th Floor</u> <u>San Francisco, CA 94111</u>	Direct Telephone Calls to: (Name, Reg. No., Telephone No.) Name: <u>Richard T. Ogawa</u> Reg. No. <u>37,692</u> Telephone: <u>415 326-2400</u>
---	--



100

Full Name of Inventor 1	Last Name Flamm	First Name Daniel	Middle Name or Initial L.	
Residence & Citizenship	City <del>Walnut Creek</del> CA	State/Foreign Country California	Country of Citizenship U.S.A.	
Post Office Address	Post Office Address 476 Green View Drive	City Walnut Creek	State/Country California	Zip Code 94596
Full Name of Inventor 2	Last Name Vinogradov	First Name Georgy	Middle Name or Initial	
Residence & Citizenship	City Yamanashi	State/Foreign Country Japan	Country of Citizenship Russia	
Post Office Address	Post Office Address Dragons Mansion Apt. 306 5860-5 Ryuchi Futaba-cho, Kitakomagun	City Yamanashi, 400-01	State/Country Japan	Zip Code
Full Name of Inventor 3	Last Name Yoneyama	First Name Shimao	Middle Name or Initial	
Residence & Citizenship	City Yamanashi	State/Foreign Country Japan	Country of Citizenship Japan	
Post Office Address	Post Office Address 5875-4 Ryuchi Futaba-cho, Kitakomagun	City Yamanashi, 400-01	State/Country Japan	Zip Code

I further declare that all statements made herein of my own knowledge are true and that all statements made on information and belief are believed to be true; and further that these statements were made with the knowledge that willful false statements and the like so made are punishable by fine or imprisonment, or both, under Section 1001 of Title 18 of the United States Code, and that such willful false statements may jeopardize the validity of the application or any patent issuing thereon.

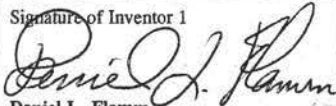
Signature of Inventor 1  Daniel L. Flamm	Signature of Inventor 2  Georgy Vinogradov	Signature of Inventor 3  Shimao Yoneyama
Date May 17, 1996	Date	Date

Full Name of Inventor 1	Last Name <b>Flamm</b>	First Name <b>Daniel</b>	Middle Name or Initial <b>L.</b>	
Residence & Citizenship	City <b>Walnut Creek</b>	State/Foreign Country <b>California</b>	Country of Citizenship <b>U.S.A.</b>	
Post Office Address	Post Office Address <b>476 Green View Drive</b>	City <b>Walnut Creek</b>	State/Country <b>California</b>	Zip Code <b>94596</b>
Full Name of Inventor 2	Last Name <b>Vinogradov</b>	First Name <b>Georgy</b>	Middle Name or Initial <b>K.</b>	
Residence & Citizenship	City <b>Yamanashi</b>	State/Foreign Country <b>Japan</b>	Country of Citizenship <b>Russia</b>	
Post Office Address	Post Office Address <b>Dragons Mansion Apt. 306 5860-5 Ryuchi Futaba-cho, Kitakomagun</b>	City <b>Yamanashi, 400-01</b>	State/Country <b>Japan</b>	Zip Code
Full Name of Inventor 3	Last Name <b>Yoneyama</b>	First Name <b>Shimao</b>	Middle Name or Initial	
Residence & Citizenship	City <b>Yamanashi</b>	State/Foreign Country <b>Japan</b>	Country of Citizenship <b>Japan</b>	
Post Office Address	Post Office Address <b>5875-4 Ryuchi Futaba-cho, Kitakomagun</b>	City <b>Yamanashi, 400-01</b>	State/Country <b>Japan</b>	Zip Code

I further declare that all statements made herein of my own knowledge are true and that all statements made on information and belief are believed to be true; and further that these statements were made with the knowledge that willful false statements and the like so made are punishable by fine or imprisonment, or both, under Section 1001 of Title 18 of the United States Code, and that such willful false statements may jeopardize the validity of the application or any patent issuing thereon.

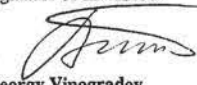
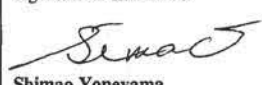
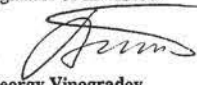
Signature of Inventor 1	Signature of Inventor 2	Signature of Inventor 3
		
Daniel L. Flamm	Georgy Vinogradov	Shimao Yoneyama
Date	Date <b>05-13-1996</b>	Date <b>05-13-1996</b>



I hereby certify that this correspondence is being deposited with the United States Postal Service as first class mail in an envelope addressed to: Assistant Commissioner for Patents, Washington, D.C. 20231, Box Missing Parts on

June 3, 1996

TOWNSEND and TOWNSEND and CREW LLP

By Alison Elzinger

PATENT

Attorney Docket No. 16655-000300

IN THE UNITED STATES PATENT AND TRADEMARK OFFICE

In re application of:	)	
Daniel L. Flamm, et al.	)	Examiner: Unassigned
Application No.: 08/567,224	)	Art Unit: Unassigned
Filed: December 4, 1995	)	PETITION TO EXTEND TIME UNDER 37
For: PROCESS DEPENDING ON PLASMA	)	CFR §1.136(a)
DISCHARGES SUSTAINED BY	)	
INDUCTIVE COUPLING	)	

Box Missing Parts  
Assistant Commissioner for Patents  
Washington, D.C. 20231

Sir:

Applicants petition the Assistant Commissioner of Patents to extend the time for response to the Notice to File Missing Parts of Application, dated February 14, 1996 for three months, from March 14, 1996 to June 14, 1996. An appropriate response to the notice in the form of a Response to Notice of Missing Parts is enclosed herewith.

Please charge \$900.00, pursuant to 37 CFR §1.17, to the Deposit Account No. 20-1430. Please charge any additional fees or credit overpayment to the above Deposit Account. This Petition is submitted in triplicate.

Respectfully submitted,

Dated: 6/1/96

Richard T. Ogawa  
Richard T. Ogawa  
Reg. No. 37,692

TOWNSEND and TOWNSEND and CREW LLP  
Two Embarcadero Center, 8th Floor  
San Francisco, California 94111-3834  
(415) 326-2400  
RTO:de  
rto\work\16655\3-petex1.tme



I hereby certify that this correspondence is being deposited with the United States Postal Service as first class mail in an envelope addressed to: Assistant Commissioner for Patents, Washington, D.C. 20231, Box Missing Parts

PATENT

Attorney Docket No. 16655-000300

on June 3, 1996  
TOWNSEND and TOWNSEND and CREW LLP  
By Blaine Elzingre

IN THE UNITED STATES PATENT AND TRADEMARK OFFICE

In re application of:	)	
Daniel L. Flamm, et al.	)	Examiner: Unassigned
Application No.: 08/567,224	)	Art Unit: Unassigned
Filed: December 4, 1995	)	PETITION TO EXTEND TIME UNDER 37
For: PROCESS DEPENDING ON PLASMA	)	CFR §1.136(a)
DISCHARGES SUSTAINED BY	)	
INDUCTIVE COUPLING	)	

Box Missing Parts  
Assistant Commissioner for Patents  
Washington, D.C. 20231

Sir:

Applicants petition the Assistant Commissioner of Patents to extend the time for response to the Notice to File Missing Parts of Application, dated February 14, 1996 for three months, from March 14, 1996 to June 14, 1996. An appropriate response to the notice in the form of a Response to Notice of Missing Parts is enclosed herewith.

Please charge \$900.00, pursuant to 37 CFR §1.17, to the Deposit Account No. 20-1430. Please charge any additional fees or credit overpayment to the above Deposit Account. This Petition is submitted in triplicate.

Respectfully submitted,

Dated: 6/1/96

Richard T. Ogawa  
Richard T. Ogawa  
Reg. No. 37,692

TOWNSEND and TOWNSEND and CREW LLP  
Two Embarcadero Center, 8th Floor  
San Francisco, California 94111-3834  
(415) 326-2400  
RTO:de  
rto\work\16655\3-petex1.tme

010 UJ 20-1430 06/13/96 08567224  
01145 117 900.00CH

1121

I hereby certify that this correspondence is being deposited with the United States Postal Service as first class mail in an envelope addressed to: Assistant Commissioner for Patents, Washington, D.C. 20231, on \_\_\_\_\_

#4

By \_\_\_\_\_

PATENT

Attorney Docket No. 16655-000300

IN THE UNITED STATES PATENT AND TRADEMARK OFFICE

In re application of: )  
 Daniel L. Flamm, et al. )  
 Serial No.: 08/567,224 )  
 Filed: December 4, 1995 )  
 For: PROCESS DEPENDING ON )  
 PLASMA DISCHARGES )  
 SUSTAINED BY INDUCTIVE )  
 COUPLING )

Examiner: <sup>Thi DANG</sup> ~~Unassigned~~

Art Unit: ~~1412~~ 1109

POWER TO INSPECT AND MAKE COPIES

RECEIVED  
NOV 08 1996  
GROUP 1100

Assistant Commissioner for Patents  
Washington, D.C. 20231

Sir:

Please permit Annette Masiello and/or Rayline Pettit to inspect and make copies of the above-identified patent application.

Respectfully submitted,

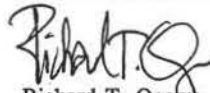

Richard T. Ogawa  
Reg. No. 37,692

Date: 11/5/96

TOWNSEND and TOWNSEND and CREW LLP  
Two Embarcadero Center, 8th Floor  
San Francisco, California 94111-3834  
(415) 326-2400

RTO:de

1665513-power.ins



130-122-DAC #5

PATENT ATTORNEY DOCKET NO. 07931/003001

IN THE UNITED STATES PATENT AND TRADEMARK OFFICE

Applicant : Flamm, Daniel L. et al. Art Unit: ~~1104~~ 1109
Serial No.: 08/567,224 Examiner: G. Goudreau
Filed : December 4, 1995
Title : PROCESS DEPENDING ON PLASMA DISCHARGES SUSTAINED BY INDUCTIVE COUPLING

Handwritten initials and date: Dony 11/22/96

Office of Petitions

AUG 2 1996

Commissioner of Patents and Trademarks Washington, DC 20231

PETITION UNDER RULE 182

Petition That Office Accept Revocation and Appointment By Fewer Than All Applicants or Owners

Petitioner MC Electronics Co., Ltd. ("MCE") is assignee of a fractional interest in the above-referenced patent application by virtue of an assignment from two of the inventors Georgy Vinogradov and Shinao Yoneyama; Daniel L. Flamm ("Flamm") is the third inventor. A dispute has arisen between MCE and its assignor-inventors, on the one hand, and Flamm on the other hand. Because of this conflict, Petitioner believes that the present attorney of record cannot act on behalf of all parties in interest.

The dispute arose because Townsend, Townsend & Crew ("Townsend"), the firm prosecuting the subject application, originally told MCE that it represented both MCE (and its two inventors) and Flamm. Townsend has unilaterally changed its mind and has recently told MCE that it only represents Flamm and is

Vertical stamp: 240 EK 7/06/95 08:57:34 1 122

Date of Deposit November 22, 1996
I hereby certify under 37 CFR 1.8(a) that this correspondence is being deposited with the United States Postal Service as first class mail with sufficient postage on the date indicated above and is addressed to the Commissioner of Patents and Trademarks, Washington, D.C. 20231.

Handwritten signature: Kristine M. McGuirk

unwilling to represent MCE or its assignor-inventors in this application.

Accordingly, Petitioner respectfully requests that the prior power of attorney to Townsend, executed by Mr. Vinogradov and Mr. Yoneyama, be revoked and the enclosed new power of attorney to Fish & Richardson be substituted under 37 CFR §3.73(b).

Petitioner respectfully requests that the Office accept the attached papers, which constitute a revocation and appointment of power of attorney for fewer than all applicants and owners, and permit the application to be prosecuted jointly.

Townsend has refused to join in this petition.

Enclosed is a check in the amount of \$130.00 in payment of the petition fee. Please apply any charges not covered, or any credits, to Deposit Account 06-1050.

Date:

11/22/96

Respectfully submitted,

  
\_\_\_\_\_  
Roger S. Borevov  
Reg. No. 20,193  
For Georgy Vinogradov,  
Shimao Yoneyama and MC  
Electronics Co., Ltd.

Fish & Richardson P.C.  
2200 Sand Hill Road, Suite 100  
Menlo Park, CA 94025  
Telephone: 415/322-5070  
Facsimile: 415/854-0875

52867.P11



PATENT  
ATTORNEY DOCKET NO. 07931/001001

IN THE UNITED STATES PATENT AND TRADEMARK OFFICE

Applicant : Flamm, Daniel L.; Vinogradov, Georgy; and  
Yoneyama, Shimao  
Serial No.: 08/567,224  
Filed : 12/04/95  
Title : PROCESS DEPENDING ON PLASMA DISCHARGES  
SUSTAINED BY INDUCTIVE COUPLING

Assistant Commissioner for Patents  
Washington, DC 20231

REVOCATION AND NEW POWER OF ATTORNEY UNDER 37 CFR §3.73(b)

The undersigned, an authorized representative of MC Electronics Co., Ltd., which has a place of business at 1-45-1, Suzuki-Cho, Kodaira-Shi, Tokyo 187, Japan, being assignee of an interest in the patent application identified above, the assignment being transmitted herewith for recordation, hereby revokes all powers of attorney previously granted by its assignors in this application and hereby appoints:

Roger S. Borovoy, Reg. No. 20,193  
William J. Egan, III, Reg. No. 28,411  
Reginald J. Suyat, Reg. No. 28,172  
Karl Bozicevic, Reg. No. 28,807  
Rene D. Tegtmeyer, Reg. No. 33,567  
Hans R. Troesch, Reg. No. 36,750  
David Goren, Reg. No. 34,609  
Mark D. Kirkland, Reg. No. 40,048  
Audrey M. Sugimura, Reg. No. 39,848  
Wayne P. Sobon, Reg. No. 32,438

as its attorneys with full power of substitution and revocation to prosecute this application and to transact all business in the United States Patent and Trademark Office connected therewith.

The undersigned has reviewed all the documents in the chain of title of the patent application identified above and, to



the best of the undersigned's knowledge and belief, title as set forth herein in the assignee as identified above.

The undersigned (whose title is supplied below) is empowered to act on behalf of the assignee.

I hereby declare that all statements made herein of my own knowledge are true and that all statements made on information and belief are believed to be true; and further that these statements were made with the knowledge that willful false statements and the like so made are punishable by fine or imprisonment, or both, under Section 1001 of Title 18 of the United States Code and that such willful false statements may jeopardize the validity of the application or any patents issued thereon.

Respectfully submitted,

Date: 10/22/96

  
Nobuaki Matsuo  
President, MC Electronics Co.,  
Ltd.

50886.P11

ASSIGNMENT

For good and valuable consideration, the receipt of which is hereby acknowledged, the undersigned ASSIGNORS hereby sell, assign, and transfer to ASSIGNEE, MC Electronics Co., Ltd., a Japanese Corporation, having its offices located at 1-45-1, Suzuki-Cho Kodaira-Shi, Tokyo 187, Japan, and the successors, assigns and legal representatives of the ASSIGNEE all of their right, title and interest for the United States and its territorial possessions and in all foreign countries in and to, any and all improvements in the invention entitled:

PROCESS DEPENDING ON PLASMA DISCHARGES SUSTAINED BY INDUCTIVE COUPLING

and which is found in the so-titled U.S. patent application Serial No. 08/567,224 filed on December 4, 1995.

and any legal equivalent thereof in a foreign country, including the right to claim priority and, in and to, all Letters Patent to be obtained for said invention by the above application or in any continuation, division, continuation-in-part, extension or substitute thereof, and any reissue, reexamination or extension of said Letters Patent and all rights under all International Conventions for the Protection of Industrial Property.

ASSIGNORS hereby covenant that no assignment, sale, agreement or encumbrance has been or will be made or entered into which would conflict with this assignment.

ASSIGNORS further covenant that ASSIGNEE will, upon its request, be provided promptly with all pertinent facts and documents relating to said invention and said Letters Patent and legal equivalents as may be known and accessible to ASSIGNORS and that ASSIGNORS will testify as to the same in any interference, litigation, or proceeding relating thereto and will promptly execute and deliver to ASSIGNEE or its legal representative any and all papers, instruments or affidavits required to apply for, obtain, maintain, issue or enforce said application, said invention and said Letters Patent and said equivalents thereof which may be necessary or desirable to carry out the purposes thereof. An attorney or record, or the attorney filing the application, is authorized and requested by the execution of this assignment to insert into this assignment the execution date of the application and/or the filing date and serial number of the application when officially known.

ASSIGNORS request the Commissioner of Patents and Trademarks to issue said Letters Patent of the United States and any reissue or extension thereof to the ASSIGNEE.

Executed this

Signature of Inventor

22nd day of October, 1996

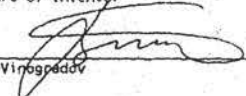
  
Georgy Vinogradov

State of California )

ss.

County of San Mateo )

On 10/22/96 before me, Georgy Vinogradov,  
personally appeared Georgy Vinogradov,  personally known to me OR  proved to me on the basis of satisfactory evidence to be the person whose name is subscribed to the within instrument and acknowledged to me that he/she executed the same in his/her individual capacity.

Witness my hand and official seal.

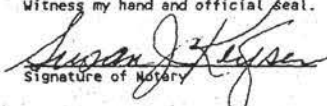

  
Signature of Notary

Executed this

Signature of Inventor

22nd day of October, 1996

*Shimeo Yoneyama*  
Shimeo Yoneyama

State of California

)

County of San Mateo

)

ss.

On 10/22/96 before me, Shimeo Yoneyama,  
personally appeared Shimeo Yoneyama, I personally known to me/OR X proved to me on the basis of satisfactory  
evidence to be the person whose name is subscribed to the within instrument and acknowledged to me that  
he/she executed the same in his/her individual capacity.

Witness my hand and official seal,



*Susan J. Keyser*  
Signature of Notary

50905.P11

RECORDED: 10/28/1996

PATENT  
REEL: 8289 FRAME: 0882



UNITED STATES DEPARTMENT OF COMMERCE  
 Patent and Trademark Office  
 ASSISTANT SECRETARY AND COMMISSIONER OF  
 PATENTS AND TRADEMARKS  
 Washington, D.C. 20231

Paper No. 6

RICHARD T. OGAWA  
 TOWNSEND & TOWNSEND & CREW  
 TWO EMBARCADERO CENTER, 8TH FLOOR  
 SAN FRANCISCO, CA 94111

**COPY MAILED**

**SEP 16 1997**

**OFFICE OF THE COMMISSIONER  
 OF PATENTS**

In re Application of :  
 Daniel L. Flamm et al. :  
 Application No. 08/567,224 :  
 Filed: December 4, 1995 :  
 For: PROCESS DEPENDING ON PLASMA :  
 DISCHARGES SUSTAINED BY INDUCTIVE :  
 COUPLING :

ON PETITION

This is a decision on the petition filed November 26, 1996, under 37 CFR 1.182, requesting acceptance of a revocation and appointment of a power of attorney made on behalf of less than all the named inventors.

The petition is granted.

The declaration filed June 6, 1996 was signed by inventors Flamm, Vinogradov, and Yoneyama, and gave power of attorney to Ogawa, Bohler, and Allen of Townsend, Townsend, and Crew LLP (TTC), at Two Embarcadero Center, 8th Floor, San Francisco CA 94111 as the correspondence address of record.

Petitioner MC Electronics Co, Ltd. (MCE) asserts that MCE is assignee of a part interest in the instant application by way of an assignment executed by Vinogradov and Yoneyama. Petitioner further asserts that TTC has represented to MCE that TTC will continue to only represent Flamm, due to a dispute that has arisen between MCE and Flamm. As such, petitioner requests that Roger Borovoy et al. of Fish and Richardson be permitted to represent the interests of MCE by way of Vinogradov, and Yoneyama. The petition is accompanied by a revocation and power of attorney pursuant to 37 CFR 3.73(b), executed on behalf of MCE.

A copy of the aforementioned assignment of the above-identified application appears at Reel 8289 Frames 0881 and 0882.

For the reasons stated above, it would be appropriate to grant the relief requested by petitioner.

However, in order to assure that all interests are properly and effectively represented, all further correspondence to the Patent and Trademark Office (PTO) must be signed by petitioner's representative (Borovoy et al.) as named in the revocation and power of attorney submitted by MCE under 37 CFR 3.73(b) and by coinventor Daniel L. Flamm, or his representative. Each attorney signing subsequent papers must indicate whom he or she represents.

All parties are reminded that dual correspondence is not permitted, and will not be undertaken by the PTO.

The PTO will continue to conduct correspondence with the attorneys first named in the application, i.e., Richard T. Ogawa, William J. Bohler, and Kenneth R. Allen, at the correspondence address of record noted above, who will also be responsible for coordinating replies or submissions to the PTO. See MPEP 402.10.

This application is being returned to Group 1100.

Telephone inquiries relative to this decision should be directed to Michael Phillips at (703) 308-6712.

*Abraham Hershkovitz*

Abraham Hershkovitz  
Director, Office of Petitions  
Office of the Deputy Assistant Commissioner  
for Patent Policy and Projects

cc: ROGER S. BOROVOY  
FISH & RICHARDSON P.C.  
2200 SAND HILL ROAD, SUITE 100  
MENLO PARK, CA 94025

08/567,224



UNITED STATES DEPARTMENT OF COMMERCE  
Patent and Trademark Office

Address: COMMISSIONER OF PATENTS AND TRADEMARKS  
Washington, D.C. 20231

SERIAL NUMBER	FILING DATE	FIRST NAMED INVENTOR	ATTORNEY DOCKET NO.
08/567,224	12/04/95	FLAMM	D 16655-000300

020350 18N2/1210  
TOWNSEND AND TOWNSEND AND CREW  
TWO EMBARCADERO CENTER EIGHTH FLOOR  
SAN FRANCISCO CA 94111

EXAMINER

LORING, S

ART UNIT	PAPER NUMBER
1802	7

DATE MAILED: 12/10/97

This is a communication from the examiner in charge of your application.  
COMMISSIONER OF PATENTS AND TRADEMARKS

- This application has been examined       Responsive to communication filed on \_\_\_\_\_       This action is made final.

A shortened statutory period for response to this action is set to expire 0 month(s), 30 days from the date of this letter.  
Failure to respond within the period for response will cause the application to become abandoned. 35 U.S.C. 133

Part I THE FOLLOWING ATTACHMENT(S) ARE PART OF THIS ACTION:

- |   |  |
|---|--|
| 1. <input type="checkbox"/> Notice of References Cited by Examiner, PTO-892.        | 2. <input type="checkbox"/> Notice re Patent Drawing, PTO-948.                   |
| 3. <input type="checkbox"/> Notice of Art Cited by Applicant, PTO-1449.             | 4. <input type="checkbox"/> Notice of Informal Patent Application, Form PTO-152. |
| 5. <input type="checkbox"/> Information on How to Effect Drawing Changes, PTO-1474. | 6. <input type="checkbox"/> _____  |

Part II SUMMARY OF ACTION

1.  Claims 1-20 are pending in the application.  
Of the above, claims \_\_\_\_\_ are withdrawn from consideration.
2.  Claims \_\_\_\_\_ have been cancelled.
3.  Claims \_\_\_\_\_ are allowed.
4.  Claims \_\_\_\_\_ are rejected.
5.  Claims \_\_\_\_\_ are objected to.
6.  Claims 1-20 are subject to restriction or election requirement.
7.  This application has been filed with Informal drawings under 37 C.F.R. 1.85 which are acceptable for examination purposes.
8.  Formal drawings are required in response to this Office action.
9.  The corrected or substitute drawings have been received on \_\_\_\_\_. Under 37 C.F.R. 1.84 these drawings are  acceptable.  not acceptable (see explanation or Notice re Patent Drawing, PTO-948).
10.  The proposed additional or substitute sheet(s) of drawings, filed on \_\_\_\_\_ has (have) been  approved by the examiner.  disapproved by the examiner (see explanation).
11.  The proposed drawing correction, filed on \_\_\_\_\_, has been  approved.  disapproved (see explanation).
12.  Acknowledgment is made of the claim for priority under U.S.C. 119. The certified copy has  been received  not been received  
 been filed in parent application, serial no. \_\_\_\_\_; filed on \_\_\_\_\_.
13.  Since this application appears to be in condition for allowance except for formal matters, prosecution as to the merits is closed in accordance with the practice under Ex parte Quayle, 1935 C.D. 11; 453 O.G. 213.
14.  Other

EXAMINER'S ACTION

PTOL-326 (Rev. 8-88)

SERIAL NUMBER 08/567,224  
ART UNIT 1802

2

1. Restriction to one of the following inventions is required under 35 U.S.C. 121:
  - I. Claims 1-11, drawn to a process for fabricating a product, classified in class 216, subclasses 67 and 73.
  - II. Claims 12-20, drawn to an apparatus for fabricating a product, classified in class 118, subclass 723R.
2. The inventions are distinct, each from the other because:

Inventions I and II are related as process of making and product made. The inventions are distinct if either or both of the following can be shown: (1) that the process as claimed can be used to make other and materially different product or (2) that the product as claimed can be made by another and materially different process (MPEP § 806.05(f)). In the instant case an apparatus for fabricating a product can be made by other known methods such as chemical dry etching or ion-assisted etching.
3. Because these inventions are distinct for the reasons given above and have acquired a separate status in the art as shown by their different classifications, restriction for examination purposes as indicated is proper.
4. Applicant is advised that the response to this requirement to be complete must include an election of the invention to be examined even though the requirement be traversed (37 CFR 1.143).
5. Applicant is reminded that upon the cancellation of claims to a non-elected invention, the inventorship must be amended in compliance with 37 CFR 1.48(b) if one or more of the currently named inventors is no longer an inventor of at least one claim remaining in the application. Any amendment of inventorship must be accompanied by a diligently-filed petition under 37 CFR 1.48(b) and by the fee required under 37 CFR 1.17(h).
6. Any inquiry concerning this communication or earlier communications from the

SERIAL NUMBER 08/567,224  
ART UNIT 1802

3

Examiner should be directed to Susan A. Loring whose telephone number is (703)308-3998.

If attempts to reach the examiner by telephone are unsuccessful, the Examiner's supervisor, James Housel, can be reached on (703) 308-4027. The fax phone number for this Group is (703) 308-4242.

Communications via Internet e-mail regarding this application, other than those under 35 U.S.C. 132 or which otherwise require a signature, may be used by the applicant and should be addressed to [james.housel@uspto.gov].

All Internet e-mail communications will be made of record in the application file. PTO employees do not engage in Internet communications where there exists a possibility that sensitive information could be identified or exchanged unless the record includes a properly signed express waiver of the confidentiality requirements of 35 U.S.C. 122. This is more clearly set forth in the Interim Internet Usage Policy published in the Official Gazette of the Patent and Trademark on February 25, 1997 at 1195 OG 89.

Any inquiry of a general nature or relating to the status of this application or proceeding should be directed to the Group receptionist whose telephone number is (703) 308-0196.

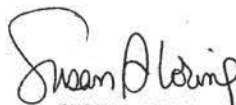

SUSAN A. LORING  
PRIMARY EXAMINER  
GROUP 1800

December 9, 1997



Attachment 08/567224

**The drawings submitted with this application were declared informal by the applicant. Accordingly they have not been reviewed by a draftsman at this time. When formal drawings are submitted, the draftsman will perform a review.**

**Direct any inquires concerning drawing review to the Drawing Review Branch (703) 305-8404.**

Attachment 08/567224

**The drawings submitted with this application were declared informal by the applicant. Accordingly they have not been reviewed by a draftsman at this time. When formal drawings are submitted, the draftsman will perform a review.**

**Direct any inquires concerning drawing review to the Drawing Review Branch (703) 305-8404.**

08/567,224



UNITED STATES DEPARTMENT OF COMMERCE  
Patent and Trademark Office  
Address: COMMISSIONER OF PATENTS AND TRADEMARKS  
Washington, D.C. 20231

08/567,224	12/04/95	FLAMM	D	16655-000300
APPLICATION NUMBER	FILING DATE	FIRST NAMED APPLICANT	ATTORNEY DOCKET NO.	

020350 HM11/0720  
TOWNSEND AND TOWNSEND AND CREW  
TWO EMBARCADERO CENTER EIGHTH FLOOR  
SAN FRANCISCO CA 94111

LORING, S

EXAMINER

1641

ART UNIT

PAPER NUMBER

12/20/98

DATE MAILED:

### NOTICE OF ABANDONMENT

This application is abandoned in view of:

- Applicant's failure to timely file a proper response to the Office letter mailed on 12/10/97.
  - A response (with a Certificate of Mailing or Transmission of \_\_\_\_\_) was received on \_\_\_\_\_, which is after the expiration of the period for response (including a total extension of time of \_\_\_\_\_ month(s)) which expired on \_\_\_\_\_.
  - A proposed response was received on \_\_\_\_\_, but it does not constitute a proper response to the final rejection.
 

(A proper response to a final rejection consists only of: a timely filed amendment which places the application in condition for allowance; a Notice of Appeal; or the filing of a continuing application under 37 CFR 1.62 (FWC).
  - No response has been received.
- Applicant's failure to timely pay the required issue fee within the statutory period of three months from the mailing date of the Notice of Allowance.
  - The issue fee (with a Certificate of Mailing or Transmission of \_\_\_\_\_) was received on \_\_\_\_\_.
  - The submitted issue fee of \$ \_\_\_\_\_ is insufficient. The issue fee required by 37 CFR 1.18 is \$ \_\_\_\_\_.
  - The issue fee has not been received.
- Applicant's failure to timely file new formal drawings as required in the Notice of Allowability.
  - Proposed new formal drawings (with a Certificate of Mailing or Transmission of \_\_\_\_\_) were received on \_\_\_\_\_.
  - The proposed new formal drawings filed \_\_\_\_\_ are not acceptable.
  - No proposed new formal drawings have been received.
- The express abandonment under 37 CFR 1.62(g) in favor of the FWC application filed on \_\_\_\_\_.
- The letter of express abandonment which is signed by the attorney or agent of record, the assignee of the entire interest, or all of the applicants.
- The letter of express abandonment which is signed by an attorney or agent (acting in a representative capacity under 37 CFR 1.34(a) upon the filing of a continuing application.
- The decision by the Board of Patent Appeals and Interferences rendered on \_\_\_\_\_ and because the period for seeking court review of the decision has expired and there are no allowed claims.
- The reason(s) below:

*Susan A. Loring*  
SUSAN A. LORING  
PRIMARY EXAMINER  
GROUP 1800/1041

FORM PTO-1432 (REV. 10-95)

**REQUEST FOR ACCESS OF ABANDONED APPLICATION UNDER 37 CFR 1.14(a)**

In re Application of	
Application Number <i>08 / 567024</i>	Filed <i>12/4/95</i>
Group Art Unit	Examiner

Paper No. 9

Assistant Commissioner for Patents  
 Washington, DC 20231

I hereby request access under 37 CFR 1.14(a)(3)(iv) to the application file record of the above-identified ABANDONED application, which is: (CHECK ONE)

- (A) referred to in United States Patent Number 6017 221, column \_\_\_\_\_
- (B) referred to in an application that is open to public inspection as set forth in 37 CFR 1.11, i.e., Application No. \_\_\_\_\_, filed \_\_\_\_\_, on page \_\_\_\_\_ of paper number \_\_\_\_\_
- (C) an application that claims the benefit of the filing date of an application that is open to public inspection, i.e., Application No. \_\_\_\_\_, filed \_\_\_\_\_, or
- (D) an application in which the applicant has filed an authorization to lay open the complete application to the public.

Please direct any correspondence concerning this request to the following address:

\_\_\_\_\_  
 \_\_\_\_\_  
 \_\_\_\_\_

*Frank H. Murphy*  
 Signature

Frank H. Murphy  
 Typed or printed name

\_\_\_\_\_  
 Date

<b>FOR PTO USE ONLY</b>	
Approved by: _____	(Initials)
Unit: _____	

Burden Hour Statement: This form is estimated to take 0.2 hours to complete. Time will vary depending upon the needs of the individual case. Any comments on the amount of time you are required to complete this form should be sent to the Chief Information Officer, Patent and Trademark Office, Washington, DC 20231. DO NOT SEND FEES OR COMPLETED FORMS TO THIS ADDRESS. SEND TO: Assistant Commissioner for Patents, Washington, DC 20231.

Under the Patent Reduction Act of 1992, no charges are required to request to a classmate or information unless it discloses a valid OMB control number.

**REQUEST FOR ACCESS OF ABANDONED APPLICATION UNDER 37 CFR 1.14(a)**

**RECEIVED**  
FEB 20 2001  
File Information Unit

In re Application of	
Application Number	Filed
08/567224	12/4/95
Group Art Unit	Examiner

Assistant Commissioner for Patents  
Washington, DC 20231

Paper No. #10

I hereby request access under 37 CFR 1.14(a)(3)(iv) to the application file record of the above-identified ABANDONED application, which is: (CHECK ONE):

- (A) referred to in United States Patent Number 6017221 column \_\_\_\_\_
- (B) referred to in an application that is open to public inspection as set forth in 37 CFR 1.11, i.e., Application No. \_\_\_\_\_ filed \_\_\_\_\_ on page \_\_\_\_\_ of paper number \_\_\_\_\_
- (C) an application that claims the benefit of the filing date of an application that is open to public inspection, i.e., Application No. \_\_\_\_\_ filed \_\_\_\_\_ or
- (D) an application in which the applicant has filed an authorization to lay open the complete application to the public.

Please direct any correspondence concerning this request to the following address:  
\_\_\_\_\_  
\_\_\_\_\_  
\_\_\_\_\_

Ricardo S. Garcia  
Signature  
RICARDO S. GARCIA  
Typed or printed name

2/20/01  
Date

FOR PTO USE ONLY	
Approved by: <u>gc</u>	(Initials)
Unit: <u>F-114</u>	

Bureau Hour Statement: This form is estimated to take 1.0 hours to complete. Time will vary depending upon the needs of the individual case. Any comments on the amount of time you are required to complete this form should be sent to the Chief Information Officer, Patent and Trademark Office, Washington, DC 20231. DO NOT SEND FEES OR COMPLETED FORMS TO THIS ADDRESS. SEND TO: Assistant Commissioner for Patents, Washington, DC 20231.



I hereby certify that this correspondence is being deposited with the United States Postal Service as first class mail in an envelope addressed to:

Assistant Commissioner for Patents,  
Washington, D.C. 20231

on April 5, 2001

TOWNSEND and TOWNSEND and CREW LLP

By Mary Bernstein

**IN THE UNITED STATES PATENT AND TRADEMARK OFFICE**

In re application of:

Daniel L. Flamm et al.

Application No.: 08/567,224

Filed: December 4, 1995

For: PROCESS DEPENDING ON PLASMA  
DISCHARGES SUSTAINED BY  
INDUCTIVE COUPLING

PATENT 17 63  
Attorney Docket No.: 016655-000300US

OPAC  
#11

Examiner:

Art Unit:

WITHDRAWAL OF  
ATTORNEY OR AGENT UNDER  
37 CFR § 1.36

Assistant Commissioner for Patents  
Washington, D.C. 20231

Sir:

Pursuant to 37 CFR § 1.36, Townsend and Townsend and Crew LLP, attorneys for applicant hereby withdraws from representation relative to the above-identified patent. Please direct all future correspondence regarding the subject patent to applicant at:

Dr. Daniel J. Flamm  
476 Green View Drive  
Walnut Creek, California 94596

By: William J. Bohler  
William J. Bohler  
Reg. No. 31,487

TOWNSEND and TOWNSEND and CREW LLP  
Two Embarcadero Center, 8th Floor  
San Francisco, CA 94111-3834  
Tel (415) 576-0200  
Fax (415) 576-0300  
PA 3135594 v1

RECEIVED  
APR 16 2001  
TC 1700 MAIL ROOM

APPROVED  
William J. Bohler  
5/16/01 TC/600  
9/13/01

Under the Paperwork Reduction Act of 1995, no persons are required to respond to a collection of information unless it displays a valid OMB control number.

**REQUEST FOR ACCESS TO AN ABANDONED APPLICATION UNDER 37 CFR 1.14**

Bring completed form to:  
File Information Unit, Room 2E04  
2900 Crystal Drive  
Arlington, VA 22202-3514

Telephone: (703) 308-2733

In re Application of

Application Number

08/567,224

Filed

Dec. 4, 1995

Paper No. 12

I hereby request access under 37 CFR 1.14(a)(1)(iv) to the application file record of the above-identified ABANDONED application, which is not within the file jacket of a pending Continued Prosecution Application (CPA) (37 CFR 1.53(d)) and which is identified in, or to which a benefit is claimed, in the following document (as shown in the attachment):

United States Patent Application Publication No. \_\_\_\_\_, page, \_\_\_\_\_ line \_\_\_\_\_

United States Patent Number 5,965,034 column 1, line, \_\_\_\_\_ or

WIPO Pub. No. \_\_\_\_\_, page \_\_\_\_\_, line \_\_\_\_\_

**Related Information About Access to Applications Maintained in the Image File Wrapper System (IFW) and Access to Pending Applications in General**

A member of the public, acting without a power to inspect, cannot order applications maintained in the IFW system through the FIU. If the member of the public is entitled to a copy of the application file, then the file is made available through the Public Patent Application Information Retrieval system (Public PAIR) on the USPTO internet web site ([www.uspto.gov](http://www.uspto.gov)). Terminals that allow access to Public PAIR are available in the Public Search Room. The member of the public may also be entitled to obtain a copy of all or part of the application file upon payment of the appropriate fee. Such copies must be purchased through the Office of Public Records upon payment of the appropriate fee (37 CFR 1.19(b)).

For published applications that are still pending, a member of the public may obtain a copy of:  
the file contents; the pending application as originally filed; or any document in the file of the pending application.

For unpublished applications that are still pending:

- (1) If the benefit of the pending application is claimed under 35 U.S.C. 119(e), 120, 121, or 365 in another application that has: (a) issued as a U.S. patent, or (b) published as a statutory invention registration, a U.S. patent application publication, or an international patent application publication in accordance with PCT Article 21(2), a member of the public may obtain a copy of: the file contents; the pending application as originally filed; or any document in the file of the pending application.
- (2) If the application is incorporated by reference or otherwise identified in a U.S. patent, a statutory invention registration, a U.S. patent application publication, or an international patent application publication in accordance with PCT Article 21(2), a member of the public may obtain a copy of the pending application as originally filed.

Andrew Kamara

Signature

ANDREW KAMARA

Typed or printed name

2-13-08

Date

FOR PTO FILE ONLY

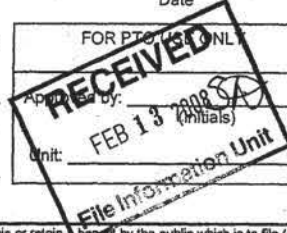

Registration Number, if applicable

(703) 838-7683

Telephone Number

This collection of information is required by 37 CFR 1.11 and 1.14. The information is required to obtain or retain a benefit by the public which is to file (and by the USPTO to process) an application. Confidentiality is governed by 35 U.S.C. 122 and 37 CFR 1.11 and 1.14. This collection is estimated to take 12 minutes to complete, including gathering, preparing, and submitting the completed application form to the USPTO. Time will vary depending upon the individual case. Any comments on the amount of time you require to complete this form and/or suggestions for reducing this burden, should be sent to the Chief Information Officer, U.S. Patent and Trademark Office, U.S. Department of Commerce, P.O. Box 1450, Alexandria, VA 22313-1450. DO NOT SEND FEES OR COMPLETED FORMS TO THIS ADDRESS. BRING TO: File Information Unit, Room 2E04, 2900 Crystal Drive, Arlington, Virginia.

If you need assistance in completing the form, call 1-800-PTO-9199 and select option 2.

**REQUEST FOR ACCESS TO AN ABANDONED APPLICATION UNDER 37 CFR 1.14**

Bring completed form to: File Information Unit, Suite 3A20 2800 South Randolph Street Arlington, VA 22206  Telephone: (703) 756-1800	In re Application of _____  <table border="1" style="width: 100%; border-collapse: collapse;"> <tr> <td style="width: 50%;">Application Number</td> <td style="width: 50%;">Filed</td> </tr> <tr> <td style="text-align: center;">056-567224</td> <td style="text-align: center;">12-4-95</td> </tr> </table>	Application Number	Filed	056-567224	12-4-95
Application Number	Filed				
056-567224	12-4-95				
<div style="border: 1px solid black; padding: 2px; display: inline-block;">                     RECEIVED                      APR 01 2011                 </div>	Paper No. <u>#113</u>				

I hereby request access under 37 CFR 1.14(a)(1)(iv) to the application file record of the above-identified ABANDONED application, which is not within the file jacket of a pending Continued Prosecution Application (CPA) (37 CFR 1.53(d)) and which is identified in, or to which a benefit is claimed, in the following document (as shown in the attachment):

United States Patent Application Publication No. \_\_\_\_\_, page \_\_\_\_\_, line \_\_\_\_\_

United States Patent Number 6017221, column \_\_\_\_\_, line \_\_\_\_\_

WIPO Pub. No. \_\_\_\_\_, page \_\_\_\_\_, line \_\_\_\_\_

**Related Information About Access to Applications Maintained in the Image File Wrapper System (IFW) and Access to Pending Applications in General**

A member of the public, acting without a power to inspect, cannot order applications maintained in the IFW system through the FIU. If the member of the public is entitled to a copy of the application file, then the file is made available through the Public Patent Application Information Retrieval system (Public PAIR) on the USPTO internet web site ([www.uspto.gov](http://www.uspto.gov)). Terminals that allow access to Public PAIR are available in the Public Search Room. The member of the public may also be entitled to obtain a copy of all or part of the application file upon payment of the appropriate fee. Such copies must be purchased through the Office of Public Records upon payment of the appropriate fee (37 CFR 1.19(b)).

**For published applications that are still pending**, a member of the public may obtain a copy of:  
 the file contents; the pending application as originally filed; or any document in the file of the pending application.

**For unpublished applications that are still pending:**

- (1) If the benefit of the pending application is claimed under 35 U.S.C. 119(e), 120, 121, or 365 in another application that has: (a) issued as a U.S. patent, or (b) published as a statutory invention registration, a U.S. patent application publication, or an international patent application publication in accordance with PCT Article 21(2), a member of the public may obtain a copy of: the file contents; the pending application as originally filed; or any document in the file of the pending application.
- (2) If the application is incorporated by reference or otherwise identified in a U.S. patent, a statutory invention registration, a U.S. patent application publication, or an international patent application publication in accordance with PCT Article 21(2), a member of the public may obtain a copy of the pending application as originally filed.

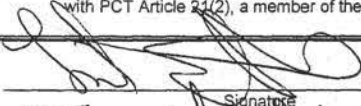
<p style="text-align: center;">                   _____                  Signature  <u>Ingrid Arbuckle</u>                  Typed of printed name             </p> <p style="text-align: center;">                 _____                  Registration Number, if applicable             </p> <p style="text-align: center;">                 _____                  Telephone Number             </p>	<p style="text-align: center;">                 Date  <u>4-1-11</u> </p> <div style="border: 1px solid black; padding: 5px; text-align: center;">                 FOR PTO USE ONLY                  APR 01 2011                  (initials)                  Unit: <u>File Information Unit</u> </div>
---	--

This collection of information is required by 37 CFR 1.11 and 1.14. The information is required to obtain or retain a benefit by the public which is to file (and by the USPTO to process) an application. Confidentiality is governed by 35 U.S.C. 122 and 37 CFR 1.11 and 1.14. This collection is estimated to take 12 minutes to complete, including gathering, preparing, and submitting the completed application form to the USPTO. Time will vary depending upon the individual case. Any comments on the amount of time you require to complete this form and/or suggestions for reducing this burden, should be sent to the Chief Information Officer, U.S. Patent and Trademark Office, U.S. Department of Commerce, P. O. Box 1450, Alexandria, VA 22313-1450. DO NOT SEND FEES OR COMPLETED FORMS TO THIS ADDRESS. BRING TO: File Information Unit, Suite 3A20, 2800 South Randolph Street, Arlington, Virginia.

*If you need assistance in completing the form, call 1-800-PTO-9199 and select option 2.*



Under the Paperwork Reduction Act of 1995, no persons are required to respond to a collection of information unless it displays a valid OMB control number.

**REQUEST FOR ACCESS TO AN ABANDONED APPLICATION UNDER 37 CFR 1.14**

Bring completed form to: File Information Unit, Suite 3A20 2800 South Randolph Street Arlington, VA 22206 Telephone: (703) 756-1800	In re Application of	
	Application Number 08/567,224	Filed 12/4/95 #14
BY: _____	Paper No. _____	

I hereby request access under 37 CFR 1.14(a)(1)(iv) to the application file record of the above-identified ABANDONED application, which is not within the file jacket of a pending Continued Prosecution Application (CPA) (37 CFR 1.53(d)) and which is identified in, or to which a benefit is claimed, in the following document (as shown in the attachment):

United States Patent Application Publication No. \_\_\_\_\_, page, \_\_\_\_\_ line \_\_\_\_\_

United States Patent Number 6017221, column Face, line, \_\_\_\_\_

-WIPO Pub. No. \_\_\_\_\_, page \_\_\_\_\_, line \_\_\_\_\_

**Related Information About Access to Applications Maintained in the Image File Wrapper System (IFW) and Access to Pending Applications in General**

A member of the public, acting without a power to inspect, cannot order applications maintained in the IFW system through the FIU. If the member of the public is entitled to a copy of the application file, then the file is made available through the Public Patent Application Information Retrieval system (Public PAIR) on the USPTO internet web site, (www.uspto.gov). Terminals that allow access to Public PAIR are available in the Public Search Room. The member of the public may also be entitled to obtain a copy of all or part of the application file upon payment of the appropriate fee. Such copies must be purchased through the Office of Public Records upon payment of the appropriate fee (37 CFR 1.19(b)).

For published applications that are still pending, a member of the public may obtain a copy of:  
 the file contents; the pending application as originally filed; or any document in the file of the pending application.

For unpublished applications that are still pending:

- (1) If the benefit of the pending application is claimed under 35 U.S.C. 119(e), 120, 121, or 365 in another application that has: (a) issued as a U.S. patent, or (b) published as a statutory invention registration, a U.S. patent application publication, or an international patent application publication in accordance with PCT Article 21(2), a member of the public may obtain a copy of: the file contents; the pending application as originally filed; or any document in the file of the pending application.
- (2) If the application is incorporated by reference or otherwise identified in a U.S. patent, a statutory invention registration, a U.S. patent application publication, or an international patent application publication in accordance with PCT Article 21(2), a member of the public may obtain a copy of the pending application as originally filed.

Michael D. Linton  
 Signature

10/2/14  
 Date

Michael D. Linton  
 Typed of printed name

Registration Number, if applicable  
703-553-0000  
 Telephone Number

FOR PTO USE ONLY	
RECEIVED Unit: OCT 02 2014 BY: _____	(initials) _____

This collection of information is required by 37 CFR 1.11 and 1.14. The information is required to obtain or retain a benefit by the public which is to file (and by the USPTO to process) an application. Confidentiality is governed by 35 U.S.C. 122 and 37 CFR 1.11 and 1.14. This collection is estimated to take 12 minutes to complete, including gathering, preparing, and submitting the completed application form to the USPTO. Time will vary depending upon the individual case. Any comments on the amount of time you require to complete this form and/or suggestions for reducing this burden, should be sent to the Chief Information Officer, U.S. Patent and Trademark Office, U.S. Department of Commerce, P.O. Box 1450, Alexandria, VA 22313-1450. DO NOT SEND FEES OR COMPLETED FORMS TO THIS ADDRESS. BRING TO: File Information Unit, Suite 3A20, 2800 South Randolph Street, Arlington, Virginia.

If you need assistance in completing the form, call 1-800-PTO-9199 and select option 2.

**REQUEST FOR ACCESS TO AN ABANDONED APPLICATION UNDER 37 CFR 1.14**

Bring completed form to:  
 File Information Unit, Suite 3A20  
 2800 South Randolph Street  
 Arlington, VA 22202  
 Telephone: (703) 756-1800  
**BY:** \_\_\_\_\_

**RECEIVED**  
 OCT 17 2014

In re Application of \_\_\_\_\_

Application Number <b>08/567,224</b>	Filed <b>Dec 4, 1995</b>
Paper No. <b>#15</b>	

I hereby request access under 37 CFR 1.14(a)(1)(iv) to the application file record of the above-identified ABANDONED application, which is not within the file jacket of a pending Continued Prosecution Application (CPA) (37 CFR 1.53(d)) and which is identified in, or to which a benefit is claimed, in the following document (as shown in the attachment):

United States Patent Application Publication No. \_\_\_\_\_, page \_\_\_\_\_, line \_\_\_\_\_

United States Patent Number \_\_\_\_\_, column \_\_\_\_\_, line \_\_\_\_\_

WIPO Pub. No. \_\_\_\_\_, page \_\_\_\_\_, line \_\_\_\_\_

**Related Information About Access to Applications Maintained in the Image File Wrapper System (IFW) and Access to Pending Applications in General**

A member of the public, acting without a power to inspect, cannot order applications maintained in the IFW system through the FIU. If the member of the public is entitled to a copy of the application file, then the file is made available through the Public Patent Application Information Retrieval system (Public PAIR) on the USPTO internet web site ([www.uspto.gov](http://www.uspto.gov)). Terminals that allow access to Public PAIR are available in the Public Search Room. The member of the public may also be entitled to obtain a copy of all or part of the application file upon payment of the appropriate fee. Such copies must be purchased through the Office of Public Records upon payment of the appropriate fee (37 CFR 1.19(b)).

For published applications that are still pending, a member of the public may obtain a copy of:  
 the file contents; the pending application as originally filed; or any document in the file of the pending application.

- For unpublished applications that are still pending:
- (1) If the benefit of the pending application is claimed under 35 U.S.C. 119(e), 120, 121, or 365 in another application that has: (a) issued as a U.S. patent, or (b) published as a statutory invention registration, a U.S. patent application publication, or an international patent application publication in accordance with PCT Article 21(2), a member of the public may obtain a copy of: the file contents; the pending application as originally filed; or any document in the file of the pending application.
  - (2) If the application is incorporated by reference or otherwise identified in a U.S. patent, a statutory invention registration, a U.S. patent application publication, or an international patent application publication in accordance with PCT Article 21(2), a member of the public may obtain a copy of the pending application as originally filed.

\_\_\_\_\_  
 Signature  
**D.H. Lucas**  
 Typed of printed name

\_\_\_\_\_  
 Registration Number, if applicable  
**571-289-0030**  
 Telephone Number

**10/17/2014**  
 Date

**FOR PTO USE ONLY**  
**RECEIVED**  
 Approved by: \_\_\_\_\_  
 Unit: **BY: R.L.R.**

This collection of information is required by 37 CFR 1.11 and 1.14. The information is required to obtain or retain a benefit by the public which is to file (and by the USPTO to process) an application. Confidentiality is governed by 35 U.S.C. 122 and 37 CFR 1.11 and 1.14. This collection is estimated to take 12 minutes to complete, including gathering, preparing, and submitting the completed application form to the USPTO. Time will vary depending upon the individual case. Any comments on the amount of time you require to complete this form and/or suggestions for reducing this burden, should be sent to the Chief Information Officer, U.S. Patent and Trademark Office, U.S. Department of Commerce, P.O. Box 1450, Alexandria, VA 22313-1450. DO NOT SEND FEES OR COMPLETED FORMS TO THIS ADDRESS. BRING TO: File Information Unit, Suite 3A20, 2800 South Randolph Street, Arlington, Virginia.

If you need assistance in completing the form, call 1-800-PTO-9199 and select option 2.

Under the Paperwork Reduction Act of 1995, no persons are required to respond to a collection of information unless it displays a valid OMB control number.

**REQUEST FOR ACCESS TO AN ABANDONED APPLICATION UNDER 37 CFR 1.14**

Bring completed form to:  
File Information Unit, Suite 3A20  
2800 South Randolph Street  
Arlington, VA 22206  
  
Telephone: (703) 756-1800

In re Application of \_\_\_\_\_

Application Number

08/567,224

Filed

12/4/95

Paper No. 16

I hereby request access under 37 CFR 1.14(a)(1)(iv) to the application file record of the above-identified ABANDONED application, which is not within the file jacket of a pending Continued Prosecution Application (CPA) (37 CFR 1.53(d)) and which is identified in, or to which a benefit is claimed, in the following document (as shown in the attachment):

United States Patent Application Publication No. \_\_\_\_\_, page, \_\_\_\_\_ line \_\_\_\_\_.

United States Patent Number 6858112, column Face, line, \_\_\_\_\_.

WIPO Pub. No. \_\_\_\_\_, page \_\_\_\_\_, line \_\_\_\_\_.

**Related Information About Access to Applications Maintained in the Image File Wrapper System (IFW) and Access to Pending Applications in General**

A member of the public, acting without a power to inspect, cannot order applications maintained in the IFW system through the FIU. If the member of the public is entitled to a copy of the application file, then the file is made available through the Public Patent Application Information Retrieval system (Public PAIR) on the USPTO internet web site ([www.uspto.gov](http://www.uspto.gov)). Terminals that allow access to Public PAIR are available in the Public Search Room. The member of the public may also be entitled to obtain a copy of all or part of the application file upon payment of the appropriate fee. Such copies must be purchased through the Office of Public Records upon payment of the appropriate fee (37 CFR 1.19(b)).

For published applications that are still pending, a member of the public may obtain a copy of:  
the file contents; the pending application as originally filed; or any document in the file of the pending application.

For unpublished applications that are still pending:

- (1) If the benefit of the pending application is claimed under 35 U.S.C. 119(e), 120, 121, or 365 in another application that has: (a) issued as a U.S. patent, or (b) published as a statutory invention registration, a U.S. patent application publication, or an international patent application publication in accordance with PCT Article 21(2), a member of the public may obtain a copy of: the file contents; the pending application as originally filed; or any document in the file of the pending application.
- (2) If the application is incorporated by reference or otherwise identified in a U.S. patent, a statutory invention registration, a U.S. patent application publication, or an international patent application publication in accordance with PCT Article 21(2), a member of the public may obtain a copy of the pending application as originally filed.

*Michael D. Linton*  
Signature

10/23/14  
Date

Michael D. Linton  
Typed of printed name

FOR PTO USE ONLY  
Approved by: *[Signature]*  
Unit: *[Stamp]*  
OCT 23 2014

Registration Number, if applicable  
703-553-0000  
Telephone Number

This collection of information is required by 37 CFR 1.11 and 1.14. The information is required to obtain or retain a benefit by the public which is to file (and by the USPTO to process) an application. Confidentiality is governed by 35 U.S.C. 122 and 37 CFR 1.11 and 1.14. This collection is estimated to take 12 minutes to complete, including gathering, preparing, and submitting the completed application form to the USPTO. Time will vary depending upon the individual case. Any comments on the amount of time you require to complete this form and/or suggestions for reducing this burden, should be sent to the Chief Information Officer, U.S. Patent and Trademark Office, U.S. Department of Commerce, P.O. Box 1450, Alexandria, VA 22313-1450. DO NOT SEND FEES OR COMPLETED FORMS TO THIS ADDRESS. BRING TO: File Information Unit, Suite 3A20, 2800 South Randolph Street, Arlington, Virginia.

If you need assistance in completing the form, call 1-800-PTO-9199 and select option 2.

Under the Paperwork Reduction Act of 1995, no persons are required to respond to a collection of information unless it displays a valid OMB control number.

**REQUEST FOR ACCESS TO AN ABANDONED APPLICATION UNDER 37 CFR 1.14**

Bring completed form to: File Information Unit, Room 2E04 2900 Crystal Drive Arlington, VA 22202-3514  Telephone: (703) 308-2733	In re Application of <b>Flamm</b>	
	Application Number <b>08/567,224</b>	Filed <b>Dec. 4, 1995</b>
		Paper No. <b>#17</b>

I hereby request access under 37 CFR 1.14(a)(1)(iv) to the application file record of the above-identified ABANDONED application, which is not within the file jacket of a pending Continued Prosecution Application (CPA) (37 CFR 1.53(d)) and which is identified in, or to which a benefit is claimed, in the following document (as shown in the attachment):

United States Patent Application Publication No. \_\_\_\_\_, page, \_\_\_\_\_ line \_\_\_\_\_  
 United States Patent Number **6017201**, column \_\_\_\_\_, line, \_\_\_\_\_ or  
 WIPO Pub. No. \_\_\_\_\_, page \_\_\_\_\_, line \_\_\_\_\_

**Related Information About Access to Applications Maintained in the Image File Wrapper System (IFW) and Access to Pending Applications in General**

A member of the public, acting without a power to inspect, cannot order applications maintained in the IFW system through the FIU. If the member of the public is entitled to a copy of the application file, then the file is made available through the Public Patent Application Information Retrieval system (Public PAIR) on the USPTO internet web site (www.uspto.gov). Terminals that allow access to Public PAIR are available in the Public Search Room. The member of the public may also be entitled to obtain a copy of all or part of the application file upon payment of the appropriate fee. Such copies must be purchased through the Office of Public Records upon payment of the appropriate fee (37 CFR 1.19(b)).

For published applications that are still pending, a member of the public may obtain a copy of the file contents; the pending application as originally filed; or any document in the file of the pending application.

For unpublished applications that are still pending:

- (1) If the benefit of the pending application is claimed under 35 U.S.C. 119(e), 120, 121, or 365 in another application that has: (a) issued as a U.S. patent, or (b) published as a statutory invention registration, a U.S. patent application publication, or an international patent application publication in accordance with PCT Article 21(2), a member of the public may obtain a copy of: the file contents; the pending application as originally filed; or any document in the file of the pending application.
- (2) If the application is incorporated by reference or otherwise identified in a U.S. patent, a statutory invention registration, a U.S. patent application publication, or an international patent application publication in accordance with PCT Article 21(2), a member of the public may obtain a copy of the pending application as originally filed.

Signature: *Jorge Salazar* Date: 3-11-15  
 Typed or printed name: Jorge Salazar  
 Registration Number, if applicable: \_\_\_\_\_  
 Telephone Number: \_\_\_\_\_

FOR PTO USE ONLY

**RECEIVED**

Approved by: [Signature]  
 MAR 10 2015

Unit: FEI-U

This collection of information is required by 37 CFR 1.11 and 1.14. The information is required to obtain or retain a benefit by the public which is to file (and by the USPTO to process) an application. Confidentiality is governed by 35 U.S.C. 122 and 37 CFR 1.11 and 1.14. This collection is estimated to take 12 minutes to complete, including gathering, preparing, and submitting the completed application form to the USPTO. Time will vary depending upon the individual case. Any comments on the amount of time you require to complete this form and/or suggestions for reducing this burden, should be sent to the Chief Information Officer, U.S. Patent and Trademark Office, U.S. Department of Commerce, P.O. Box 1450, Alexandria, VA 22313-1450. DO NOT SEND FEES OR COMPLETED FORMS TO THIS ADDRESS. BRING TO: File Information Unit, Room 2E04, 2900 Crystal Drive, Arlington, Virginia.

Under the Paperwork Reduction Act of 1995, no persons are required to respond to a collection of information unless it displays a valid OMB control number.

## REQUEST FOR ACCESS TO AN ABANDONED APPLICATION UNDER 37 CFR 1.14

Bring completed form to:  
File Information Unit, Suite 3A20  
2800 South Randolph Street  
Arlington, VA 22206

Telephone: (703) 756-1800

In re Application of

**Daniel L. FLAMM**

Application Number

**08/567,224**

Filed

**December 4, 1995**Paper No. 18

I hereby request access under 37 CFR 1.14(a)(1)(iv) to the application file record of the above-identified ABANDONED application, which is not within the file jacket of a pending Continued Prosecution Application (CPA) (37 CFR 1.53(d)) and which is identified in, or to which a benefit is claimed, in the following document (as shown in the attachment):

United States Patent Application Publication No. \_\_\_\_\_, page \_\_\_\_\_, line \_\_\_\_\_.

United States Patent Number 5,965,034 Page 1 item [63]

WIPO Pub. No. \_\_\_\_\_, page \_\_\_\_\_, line \_\_\_\_\_.

**Related Information About Access to Applications Maintained in the Image File Wrapper System (IFW) and Access to Pending Applications in General**

A member of the public, acting without a power to inspect, cannot order applications maintained in the IFW system through the FIU. If the member of the public is entitled to a copy of the application file, then the file is made available through the Public Patent Application Information Retrieval system (Public PAIR) on the USPTO Internet web site ([www.uspto.gov](http://www.uspto.gov)). Terminals that allow access to Public PAIR are available in the Public Search Room. The member of the public may also be entitled to obtain a copy of all or part of the application file upon payment of the appropriate fee. Such copies must be purchased through the Office of Public Records upon payment of the appropriate fee (37 CFR 1.19(b)).

For published applications that are still pending, a member of the public may obtain a copy of:  
the file contents; the pending application as originally filed; or any document in the file of the pending application.

For unpublished applications that are still pending:

- (1) If the benefit of the pending application is claimed under 35 U.S.C. 119(e), 120, 121, or 365 in another application that has: (a) issued as a U.S. patent, or (b) published as a statutory invention registration, a U.S. patent application publication, or an international patent application publication in accordance with PCT Article 21(2), a member of the public may obtain a copy of: the file contents; the pending application as originally filed; or any document in the file of the pending application.
- (2) If the application is incorporated by reference or otherwise identified in a U.S. patent, a statutory invention registration, a U.S. patent application publication, or an international patent application publication in accordance with PCT Article 21(2), a member of the public may obtain a copy of the pending application as originally filed.

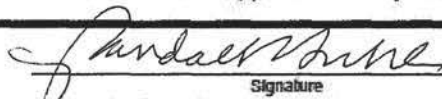

Signature

Randall S. Svihla

Typed of printed name

56,273

Registration Number, if applicable

(202) 429-0020, ext. 305

Telephone Number

March 16, 2015

Date

FOR PTO USE ONLY

Approved by:



Unit:

BY: \_\_\_\_\_

This collection of information is required by 37 CFR 1.11 and 1.14. The information is required to obtain or retain a benefit by the public which is to file (and by the USPTO to process) an application. Confidentiality is governed by 35 U.S.C. 122 and 37 CFR 1.11 and 1.14. This collection is estimated to take 12 minutes to complete, including gathering, preparing, and submitting the completed application form to the USPTO. Time will vary depending upon the individual case. Any comments on the amount of time you require to complete this form and/or suggestions for reducing this burden, should be sent to the Chief Information Officer, U.S. Patent and Trademark Office, U.S. Department of Commerce, P.O. Box 1450, Alexandria, VA 22313-1450. DO NOT SEND FEES OR COMPLETED FORMS TO THIS ADDRESS. BRING TO: File Information Unit, Suite 3A20, 2800 South Randolph Street, Arlington, Virginia.

If you need assistance in completing the form, call 1-800-PTO-9199 and select option 2.

Under the Paperwork Reduction Act of 1995, no persons are required to respond to a collection of information unless it displays a valid OMB control number.

**REQUEST FOR ACCESS TO AN ABANDONED APPLICATION UNDER 37 CFR 1.14**

Bring completed form to: File Information Unit, Suite 3A20 2800 South Randolph Street Arlington, VA 22206  Telephone: (703) 756-1800	In re Application of	
	Application Number <b>08-567224</b>	Filed <b>12-4-95</b>

Paper No. **#19**

I hereby request access under 37 CFR 1.14(a)(1)(iv) to the application file record of the above-identified ABANDONED application, which is not within the file jacket of a pending Continued Prosecution Application (CPA) (37 CFR 1.53(d)) and which is identified in, or to which a benefit is claimed, in the following document (as shown in the attachment):

United States Patent Application Publication No. \_\_\_\_\_, page, \_\_\_\_\_ line \_\_\_\_\_  
 United States Patent Number **6858112**, column \_\_\_\_\_, line, \_\_\_\_\_  
 WIPO Pub. No. \_\_\_\_\_, page \_\_\_\_\_, line \_\_\_\_\_

**Related Information About Access to Applications Maintained in the Image File Wrapper System (IFW) and Access to Pending Applications in General**

A member of the public, acting without a power to inspect, cannot order applications maintained in the IFW system through the FIU. If the member of the public is entitled to a copy of the application file, then the file is made available through the Public Patent Application Information Retrieval system (Public PAIR) on the USPTO internet web site (www.uspto.gov). Terminals that allow access to Public PAIR are available in the Public Search Room. The member of the public may also be entitled to obtain a copy of all or part of the application file upon payment of the appropriate fee. Such copies must be purchased through the Office of Public Records upon payment of the appropriate fee (37 CFR 1.19(b)).

For published applications that are still pending, a member of the public may obtain a copy of:  
 the file contents; the pending application as originally filed; or any document in the file of the pending application.

- For unpublished applications that are still pending:
- (1) If the benefit of the pending application is claimed under 35 U.S.C. 119(e), 120, 121, or 365 in another application that has: (a) issued as a U.S. patent, or (b) published as a statutory invention registration, a U.S. patent application publication, or an international patent application publication in accordance with PCT Article 21(2), a member of the public may obtain a copy of: the file contents; the pending application as originally filed; or any document in the file of the pending application.
  - (2) If the application is incorporated by reference or otherwise identified in a U.S. patent, a statutory invention registration, a U.S. patent application publication, or an international patent application publication in accordance with PCT Article 21(2), a member of the public may obtain a copy of the pending application as originally filed.

*[Handwritten Signature]*  
 Signature  
 Fred A. Helle  
 Typed or printed name

**3-26-15**  
 Date

Registration Number, if applicable  
**202-345 8845**  
 Telephone Number

FOR OFFICIAL USE ONLY Approved by <b>MAR 26 2015</b> (Initials) Unit: <i>[Signature]</i>
--

This collection of information is required by 37 CFR 1.11 and 1.14. The information is required to obtain or retain a benefit by the public which is to file (and by the USPTO to process) an application. Confidentiality is governed by 35 U.S.C. 122 and 37 CFR 1.11 and 1.14. This collection is estimated to take 12 minutes to complete, including gathering, preparing, and submitting the completed application form to the USPTO. Time will vary depending upon the individual case. Any comments on the amount of time you require to complete this form and/or suggestions for reducing this burden, should be sent to the Chief Information Officer, U.S. Patent and Trademark Office, U.S. Department of Commerce, P.O. Box 1450, Alexandria, VA 22313-1450. DO NOT SEND FEES OR COMPLETED FORMS TO THIS ADDRESS. BRING TO: File Information Unit, Suite 3A20, 2800 South Randolph Street, Arlington, Virginia.

*If you need assistance in completing the form, call 1-800-PTO-9199 and select option 2.*

**REQUEST FOR ACCESS TO AN ABANDONED APPLICATION UNDER 37 CFR 1.14**

<p><i>Bring completed form to:</i> File Information Unit, Suite 3A20 2800 South Randolph Street Arlington, VA 22206</p> <p>Telephone: (703) 756-1800</p>	<p>In re Application of <b>Flamm</b></p> <table border="1" style="width: 100%; border-collapse: collapse;"> <tr> <td style="width: 50%;">Application Number <b>08/567,224</b></td> <td style="width: 50%;">Filed <b>12, 4, 95</b></td> </tr> </table>	Application Number <b>08/567,224</b>	Filed <b>12, 4, 95</b>
Application Number <b>08/567,224</b>	Filed <b>12, 4, 95</b>		
<p>APR 02 2015</p>	<p>Paper No. <b>#20</b></p>		
<p>BY: _____</p>			

I hereby request access under 37 CFR 1.14(a)(1)(iv) to the application file record of the above-identified ABANDONED application, which is not within the file jacket of a pending Continued Prosecution Application (CPA) (37 CFR 1.53(d)) and which is identified in, or to which a benefit is claimed, in the following document (as shown in the attachment):

United States Patent Application Publication No. \_\_\_\_\_, page \_\_\_\_\_, line \_\_\_\_\_

United States Patent Number **6858112**, column \_\_\_\_\_, line \_\_\_\_\_

WIPO Pub. No. \_\_\_\_\_, page \_\_\_\_\_, line \_\_\_\_\_

**Related Information About Access to Applications Maintained in the Image File Wrapper System (IFW) and Access to Pending Applications in General**

A member of the public, acting without a power to inspect, cannot order applications maintained in the IFW system through the FIU. If the member of the public is entitled to a copy of the application file, then the file is made available through the Public Patent Application Information Retrieval system (Public PAIR) on the USPTO internet web site ([www.uspto.gov](http://www.uspto.gov)). Terminals that allow access to Public PAIR are available in the Public Search Room. The member of the public may also be entitled to obtain a copy of all or part of the application file upon payment of the appropriate fee. Such copies must be purchased through the Office of Public Records upon payment of the appropriate fee (37 CFR 1.19(b)).

For published applications that are still pending, a member of the public may obtain a copy of:  
the file contents; the pending application as originally filed; or any document in the file of the pending application.

For unpublished applications that are still pending:

- (1) If the benefit of the pending application is claimed under 35 U.S.C. 119(e), 120, 121, or 365 in another application that has: (a) issued as a U.S. patent, or (b) published as a statutory invention registration, a U.S. patent application publication, or an international patent application publication in accordance with PCT Article 21(2), a member of the public may obtain a copy of: the file contents; the pending application as originally filed; or any document in the file of the pending application.
- (2) If the application is incorporated by reference or otherwise identified in a U.S. patent, a statutory invention registration, a U.S. patent application publication, or an international patent application publication in accordance with PCT Article 21(2), a member of the public may obtain a copy of the pending application as originally filed.

**4-2-15**  
Date

**KELVIN Rodriguez**  
Signature

**KELVIN Rodriguez**  
Typed of printed name

Registration Number, if applicable  
\_\_\_\_\_

**(703) 519-2018**  
Telephone Number

**FOR PTO USE ONLY**

Approved by: \_\_\_\_\_  
(initials)  
**APR 02 2015**

Unit: \_\_\_\_\_

BY: \_\_\_\_\_

This collection of information is required by 37 CFR 1.11 and 1.14. The information is required to obtain or retain a benefit by the public which is to file (and by the USPTO to process) an application. Confidentiality is governed by 35 U.S.C. 122 and 37 CFR 1.11 and 1.14. This collection is estimated to take 12 minutes to complete, including gathering, preparing, and submitting the completed application form to the USPTO. Time will vary depending upon the individual case. Any comments on the amount of time you require to complete this form and/or suggestions for reducing this burden, should be sent to the Chief Information Officer, U.S. Patent and Trademark Office, U.S. Department of Commerce, P.O. Box 1450, Alexandria, VA 22313-1450. DO NOT SEND FEES OR COMPLETED FORMS TO THIS ADDRESS. BRING TO: File Information Unit, Suite 3A20, 2800 South Randolph Street, Arlington, Virginia.

*If you need assistance in completing the form, call 1-800-PTO-9199 and select option 2.*



(12) **United States Patent**  
Flamm et al.

(10) Patent No.: **US 6,858,112 B2**  
(45) Date of Patent: **Feb. 22, 2005**

- (54) **PROCESS DEPENDING ON PLASMA DISCHARGES SUSTAINED BY INDUCTIVE COUPLING**
- (75) Inventors: **Daniel L. Flamm, Walnut Creek, CA (US); Georgy K. Vinogradov, Kanagawa (JP); Shimaoy Yoneyama, Yamanashi (JP)**
- (73) Assignee: **Hitachi Kokusai Electric Co., Ltd., Tokyo (JP)**

5,361,016 A	11/1994	Ohkawa et al.
5,405,480 A	4/1995	Benzing et al.
5,431,968 A	7/1995	Miller et al.
5,534,231 A	7/1996	Savas
5,571,366 A	* 11/1996	Ishii et al.
5,573,595 A	11/1996	Dible
5,591,493 A	* 1/1997	Paranjpe et al. .... 427/569
5,637,961 A	6/1997	Ishii et al.
5,965,034 A	* 10/1999	Vinogradov et al. .... 216/68
6,017,221 A	* 1/2000	Flamm ..... 438/14
6,127,275 A	* 10/2000	Flamm ..... 438/710

(\*) Notice: Subject to any disclaimer, the term of this patent is extended or adjusted under 35 U.S.C. 154(b) by 486 days.

(21) Appl. No.: **08/748,746**  
(22) Filed: **Nov. 18, 1996**

(65) **Prior Publication Data**  
US 2003/0168427 A1 Sep. 11, 2003

- Related U.S. Application Data**
- (63) Continuation-in-part of application No. 08/567,224, filed on Dec. 4, 1995, now abandoned.
  - (51) Int. Cl.<sup>7</sup> ..... **C23C 16/00; C23F 1/00**
  - (52) U.S. Cl. .... **156/345.48; 118/723 I; 216/68; 438/714; 427/569**
  - (58) Field of Search ..... **118/723 I, 723 IR, 118/723 AN; 315/111.51; 156/345.48, 345.49, 345; 216/68; 438/714; 427/569**

- (56) **References Cited**  
**U.S. PATENT DOCUMENTS**
- |             |        |                  |
|-------------|--------|------------------|
| 3,873,884 A | 3/1975 | Gabriel          |
| 4,368,092 A | 1/1983 | Steinberg et al. |
| 4,918,031 A | 4/1990 | Flamm et al.     |
| 4,943,345 A | 7/1990 | Asmussen et al.  |
| 5,234,529 A | 8/1993 | Johnson          |
| 5,241,245 A | 8/1993 | Barnes et al.    |
| 5,304,282 A | 4/1994 | Flamm            |

**OTHER PUBLICATIONS**

Asmussen et al., "The Design of a Microwave Plasma Cavity," *Proc. of IEEE*, 62(1):109-117 (Jan. 1974).  
 Eckert, "The Hundred Year History of Induction Discharge," *2<sup>nd</sup> Ann. Int'l Conf. Plasma Chem. Tech.*, (1984).  
 Fossheim et al., "Broadband tuning of helical resonant cavities," *J. Phys. E. Sci. Instrum.*, 11:892-893 (1978).  
 Niazi et al., "Operation of a helical resonator plasma source," *Plasma Sources Sci. Technol.*, 3:482-495 (1994).  
 Roppel et al., "Low temperature oxidation of silicon using a microwave plasma disk source," *J. Vac. sci. Technol.*, B4(1):295-298 (Jan./Feb. 1986).  
 Zverev et al., "Realization of a Filter with Helical Components," *IRE Trans. on Component Parts*, pp. 99-110, (Sep. 1961).

\* cited by examiner

*Primary Examiner*—Luz Alejandro-Mulero  
(74) *Attorney, Agent, or Firm*—Townsend and Townsend and Crew LLP

(57) **ABSTRACT**

A process for fabricating a product 28, 119. The process comprises the steps of subjecting a substrate to a composition of entities, at least one of the entities emanating from a species generated by a gaseous discharge excited by a high frequency field in which the vector sum of currents to phase and inverse-phase capacitive coupled voltages from the inductive coupling structure can be selectively maintained.

14 Claims, 14 Drawing Sheets

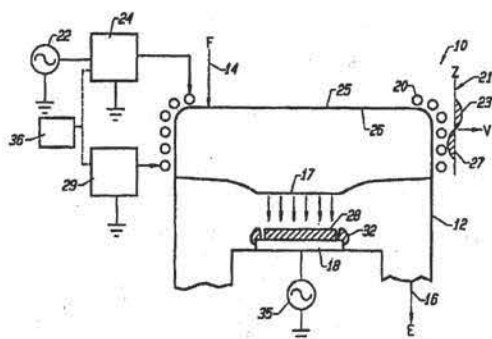



**PATENT APPLICATION FEE DETERMINATION RECORD**

Effective October 1, 1995

Application or Docket Number

567224

**CLAIMS AS FILED - PART I**

FOR	NUMBER FILED (Column 1)	NUMBER EXTRA (Column 2)
BASIC FEE		
TOTAL CLAIMS	20	minus 20 = *
INDEPENDENT CLAIMS	3	minus 3 = *
MULTIPLE DEPENDENT CLAIM PRESENT		

SMALL ENTITY		OR	OTHER THAN SMALL ENTITY	
RATE	FEE		RATE	FEE
	375.00	OR		750.00
x\$11=		OR	x\$22=	
x39=		OR	x78=	
+125=		OR	+250=	
TOTAL		OR	TOTAL	250

\* If the difference in column 1 is less than zero, enter "0" in column 2

**CLAIMS AS AMENDED - PART II**

AMENDMENT A	CLAIMS REMAINING AFTER AMENDMENT	HIGHEST NUMBER PREVIOUSLY PAID FOR	PRESENT EXTRA
	(Column 1)	(Column 2)	(Column 3)
Total	*	Minus **	=
Independent	*	Minus ***	=
FIRST PRESENTATION OF MULTIPLE DEPENDENT CLAIM			

SMALL ENTITY		OR	OTHER THAN SMALL ENTITY	
RATE	ADDITIONAL FEE		RATE	ADDITIONAL FEE
x\$11=		OR	x\$22=	
x39=		OR	x78=	
+125=		OR	+250=	
TOTAL ADDIT. FEE		OR	TOTAL ADDIT. FEE	

AMENDMENT B	CLAIMS REMAINING AFTER AMENDMENT	HIGHEST NUMBER PREVIOUSLY PAID FOR	PRESENT EXTRA
	(Column 1)	(Column 2)	(Column 3)
Total	*	Minus **	=
Independent	*	Minus ***	=
FIRST PRESENTATION OF MULTIPLE DEPENDENT CLAIM			

SMALL ENTITY		OR	OTHER THAN SMALL ENTITY	
RATE	ADDITIONAL FEE		RATE	ADDITIONAL FEE
x\$11=		OR	x\$22=	
x39=		OR	x78=	
+125=		OR	+250=	
TOTAL ADDIT. FEE		OR	TOTAL ADDIT. FEE	

AMENDMENT C	CLAIMS REMAINING AFTER AMENDMENT	HIGHEST NUMBER PREVIOUSLY PAID FOR	PRESENT EXTRA
	(Column 1)	(Column 2)	(Column 3)
Total	*	Minus **	=
Independent	*	Minus ***	=
FIRST PRESENTATION OF MULTIPLE DEPENDENT CLAIM			

SMALL ENTITY		OR	OTHER THAN SMALL ENTITY	
RATE	ADDITIONAL FEE		RATE	ADDITIONAL FEE
x\$11=		OR	x\$22=	
x39=		OR	x78=	
+125=		OR	+250=	
TOTAL ADDIT. FEE		OR	TOTAL ADDIT. FEE	

\* If the entry in column 1 is less than the entry in column 2, write "0" in column 3.  
 \*\* If the "Highest Number Previously Paid For" IN THIS SPACE is less than 20, enter "20."  
 \*\*\* If the "Highest Number Previously Paid For" IN THIS SPACE is less than 3, enter "3."  
 The "Highest Number Previously Paid For" (Total or Independent) is the highest number found in the appropriate box in column 1.

1 2AE 5AC 9

Form PTO 1130 (REV 2/94)

**PACE DATA ENTRY CODING SHEET**

U.S. DEPARTMENT OF COMMERCE  
Patent and Trademark Office

1ST EXAMINER <i>Wellborn</i>	DATE 2/28
2ND EXAMINER <i>Dill</i>	DATE 6/22/88
SPECIAL HANDLING	CLASS 427
FILING DATE MONTH: 12 DAY: 20 YEAR: 85	GROUP ART UNIT 11112
TYPE APPL <input type="checkbox"/> 1	SHEETS OF DRAWING 13
SMALL ENTITY? <input type="checkbox"/> 0	ATTORNEY DOCKET NUMBER 160555-1000300

APPLICATION NUMBER 08/567224	TOTAL CLAIMS 20	INDEPENDENT CLAIMS 3	FILING FEE 08880	FOREIGN LICENSE 1
---------------------------------	--------------------	-------------------------	---------------------	----------------------

**CONTINUITY DATA**

CONT STATUS CODE	PARENT APPLICATION SERIAL NUMBER	PCT APPLICATION SERIAL NUMBER	PARENT PATENT NUMBER	PARENT FILING DATE		
				MONTH	DAY	YEAR
P		/				
P		/				
P		/				
P		/				
P		/				

**PCT/FOREIGN APPLICATION DATA**

FOREIGN PRIORITY CLAIMED	COUNTRY CODE	PCT/FOREIGN APPLICATION SERIAL NUMBER	FOREIGN FILING DATE		
			MONTH	DAY	YEAR