

12

**EUROPEAN PATENT APPLICATION**

21 Application number: 84300821.0

51 Int. Cl.<sup>3</sup>: **G 01 P 3/50**

**G 01 C 22/02, G 04 B 47/06**

22 Date of filing: 09.02.84

30 Priority: 09.02.83 US 465274

43 Date of publication of application:  
19.09.84 Bulletin 84/38

84 Designated Contracting States:  
DE FR GB IT

71 Applicant: Nike International Ltd.  
3900 S.W. Murray Boulevard  
Beaverton Oregon 97005(US)

72 Inventor: Frederick, Edward C.  
107 Main Street  
Kingston New Hampshire 03848(US)

74 Representative: Frost, Dennis Thomas et al,  
WITHERS & ROGERS 4 Dyer's Buildings Holborn  
London, EC1N 2JT(GB)

54 A device for determining the speed, distance traversed, elapsed time and calories expended by a person while running.

57 A device for measuring the speed of a person while running along a surface is disclosed. A pressure switch or transducer (3) located in a shoe senses when a foot of the runner is in contact with the surface and produces a foot contact signal having a duration proportional to the time the foot is in contact with the surface. A radio frequency transmitter (1) is coupled to the pressure switch or transducer (3) and transmits the foot contact signal. A radio frequency receiver (4) receives the foot contact signal transmitted by the frequency transmitter (1) and a microprocessor (5) coupled to the radio frequency receiver (4) calculates, solely from the foot contact signal, an output speed signal representing the speed of the runner. A liquid crystal display (7) coupled to the output of the microprocessor (5) displays the speed of the runner in accordance with the output speed signal.

0 119 009 A1

FIG. 4.

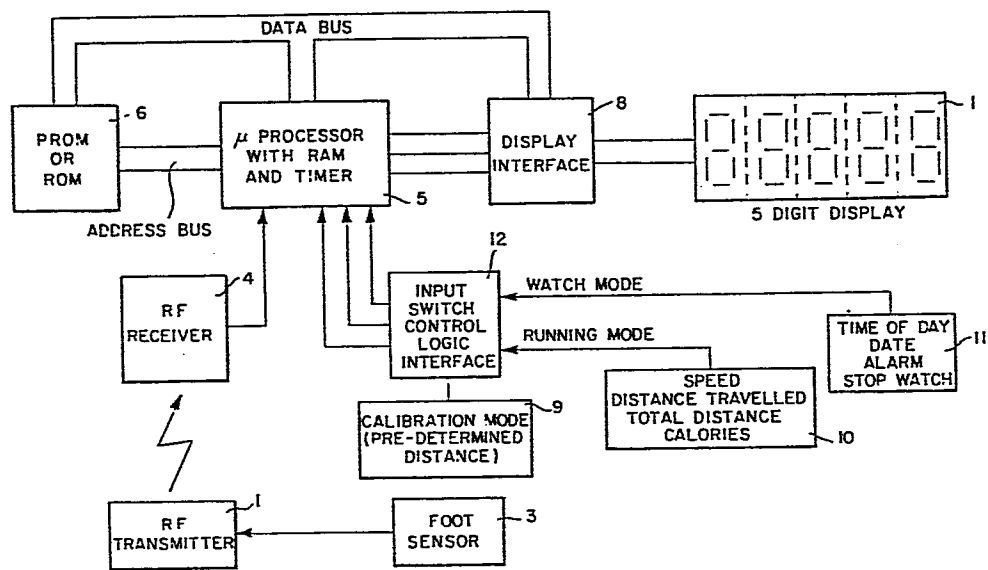

A DEVICE FOR DETERMINING THE SPEED, DISTANCE  
TRAVERSED, ELAPSED TIME AND CALORIES EXPENDED  
BY A PERSON WHILE RUNNING

BACKGROUND OF THE INVENTION

This invention relates generally to the field of measuring instruments and is particularly directed to a method and apparatus for determining the speed, distance traversed, running elapsed time and calories expended by a person while running.

In recent years, concern over the increasing numbers of cardiovascular illnesses reported each year has led to much greater public awareness of the importance of maintaining good physical body conditioning. This concern has spawned the development of a wide variety of health spas, fitness centers and other similar commercial establishments. While many of these facilities offer excellent fitness programs, a large number of individuals are foreclosed from participation because they do not have the time, financial resources or a convenient schedule to devote to a professionally supervised fitness program. Many individuals have, therefore, turned to their own fitness program of regular jogging. As used herein, jogging is also intended to include running and the two words are used interchangeably.

Jogging has long been recognized for its therapeutic effects on the body. It increases cardiopulmonary fitness, helps to lower blood pressure, decreases cholesterol and triglycerides associated with heart disease and reduces weight. Jogging is also one of the easiest exercises to do. It requires no athletic ability and can be done almost any time and any place with a minimum of equipment and without

assistance. In more recent times, jogging has also gained acceptance for its recreational value as well and is recognized as a positive factor in establishing psychological stability. The popularity of jogging today is well documented by the large numbers of products and literature available to the running public.

As in many exercise and sporting endeavors, there exists in the prior art a wide variety of devices for aiding those who jog. The simplest running aids are basic pacing timers as disclosed in U.S. Patent No. 3,540,344 to Veech and U.S. Patent No. 3,882,480 to Greber. Pacing timers generate a repetitive audio tone signal at selected intervals for pacing the strides of the runner. The length of the interval between tones is adjusted to suit the pace of the individual jogger.

There are other running aids known in the prior art such as pedometers as disclosed in U.S. Patent No. 4,053,755 to Sherrill. These devices usually count the number of steps taken and for a particular stride length, the approximate distance traversed can be determined.

While pacing timers and pedometers are useful to the jogger, they are deficient in several areas. For example, it is known that above a certain speed, stride length begins to increase as speed increases. The relationship of stride length to speed is not directly proportional and is different for each jogger. It is, therefore, a difficult task to determine the correct stride length for an individual jogger at various speeds. Thus, pacing timers can provide no more than a constant running pace and pedometers are only useful as an approximation of distance traversed.

Running aids known in the prior art are further deficient in that they add weight to the runner while providing only marginal utility in terms of the amount of information available and its accuracy. Further, it has become desirable to accurately measure the speed of amateur and professional runners, both in training and during

competition. In the prior art, such measurements were made with a stop watch timing the runner over a known distance. Heretofore, it has not been possible to obtain accurate instantaneous speeds of runners using the measuring devices currently known in the prior art.

With the foregoing in mind, the ideal running aid should, therefore:

1. be light in weight;
2. serve a number of useful functions;
3. be inexpensive;
4. provide measurements that are readily available to the user;
5. be reliable and easy to use; and.
6. provide accurate measurements of speed, distance traversed, running time elapsed, calories expended and other useful information.

SUMMARY OF THE INVENTION

It is the overall object of this invention to provide a new and improved running aid which overcomes the disadvantages of the prior art devices and substantially increases the amount and accuracy of information available to the jogger.

A specific object of this invention is to provide a new and improved running aid in which the speed of the runner or jogger can be easily and accurately determined.

A further specific object of this invention is to provide a new and improved running aid in which the distance traversed by the runner or jogger can be easily and accurately determined.

A still further specific object of this invention is to provide a new and improved running aid in which the elapsed time of the run can be determined.

Another specific object of this invention is to provide a new and improved running aid in which the calories expended by the runner or jogger can be easily determined.

# Explore Litigation Insights

Docket Alarm provides insights to develop a more informed litigation strategy and the peace of mind of knowing you're on top of things.

## Real-Time Litigation Alerts



Keep your litigation team up-to-date with **real-time alerts** and advanced team management tools built for the enterprise, all while greatly reducing PACER spend.

Our comprehensive service means we can handle Federal, State, and Administrative courts across the country.

## Advanced Docket Research



With over 230 million records, Docket Alarm's cloud-native docket research platform finds what other services can't. Coverage includes Federal, State, plus PTAB, TTAB, ITC and NLRB decisions, all in one place.

Identify arguments that have been successful in the past with full text, pinpoint searching. Link to case law cited within any court document via Fastcase.

## Analytics At Your Fingertips



Learn what happened the last time a particular judge, opposing counsel or company faced cases similar to yours.

Advanced out-of-the-box PTAB and TTAB analytics are always at your fingertips.

## API

Docket Alarm offers a powerful API (application programming interface) to developers that want to integrate case filings into their apps.

## LAW FIRMS

Build custom dashboards for your attorneys and clients with live data direct from the court.

Automate many repetitive legal tasks like conflict checks, document management, and marketing.

## FINANCIAL INSTITUTIONS

Litigation and bankruptcy checks for companies and debtors.

## E-DISCOVERY AND LEGAL VENDORS

Sync your system to PACER to automate legal marketing.