

[54] **PEDOMETER TOY**

[76] Inventor: **Carl B. Biro**, 126 Linn Ave.,
Yonkers, N.Y. 10705

[22] Filed: **May 21, 1973**

[21] Appl. No.: **362,265**

[52] U.S. Cl. **235/105**

[51] Int. Cl. **G01c 22/00**

[58] Field of Search **235/105**

[56] **References Cited**

UNITED STATES PATENTS

694,652	3/1902	Kuhn	235/105
1,684,928	9/1928	Simpson.....	233/105 X

Primary Examiner—Lawrence R. Franklin
Attorney, Agent, or Firm—John W. Melville; Albert E. Strasser; Stanley H. Foster

[57] **ABSTRACT**

A pedometer toy comprising a support for means for indicating the number of feet and fractions of a mile traversed together with the drive mechanism for the indicator means. The drive mechanism comprises a pendulum, a ratchet wheel and pawl and a gear train. The support and its associated indicator means and drive mechanism are enclosed in a case affixable to the wearer's body. Finally, means are provided to set the indicator means to any desired reading.

12 Claims, 5 Drawing Figures

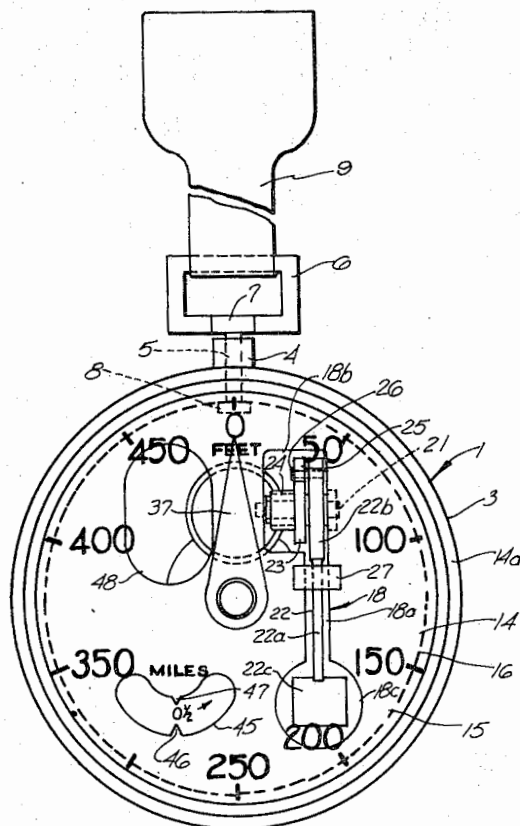

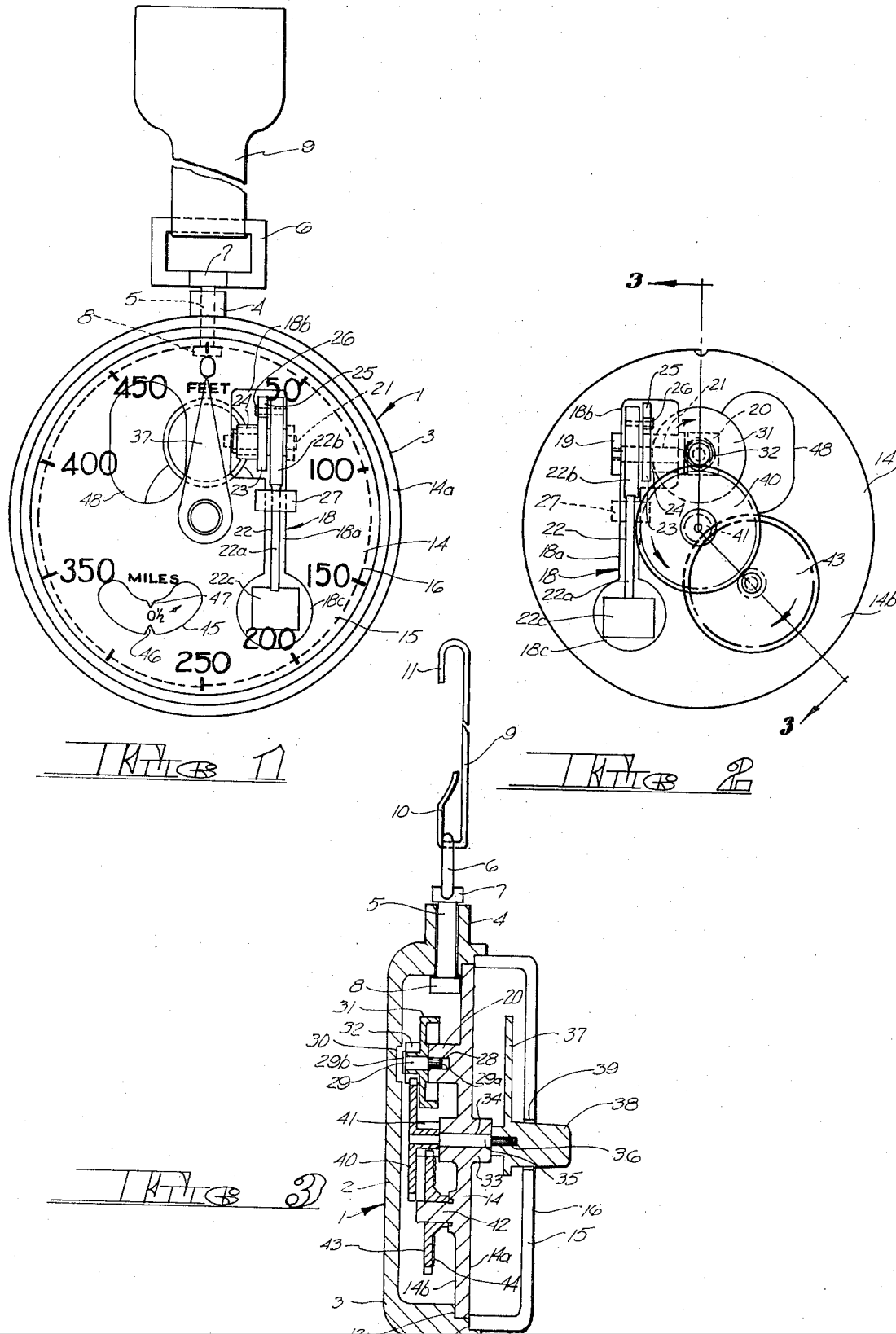
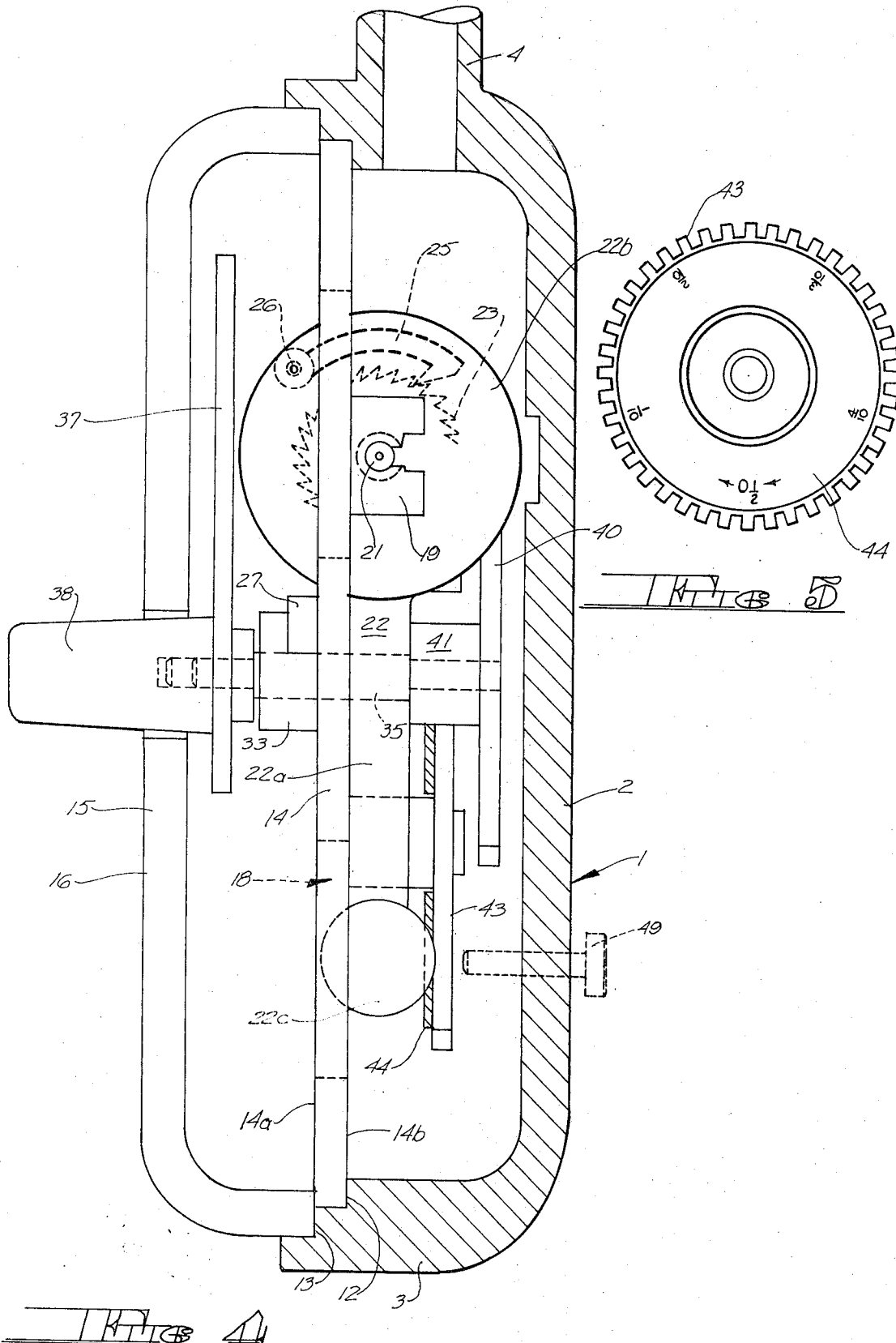

FIG. 1

FIG. 2

FIG. 3



PEDOMETER TOY

BACKGROUND OF THE INVENTION

1. Field of the Invention

The invention relates to a pedometer toy, and more particularly to a pedometer capable of indicating with reasonable accuracy the number of feet and the fractions of a mile traversed, while at the same time being simple in design and inexpensive to manufacture.

2. Description of the Prior Art

Prior art workers have heretofore devised various types of pedometers, but for many years very little work has been done to further develop such instruments. The prior art pedometers have generally been characterized by complex and expensive spring-driven mechanisms. Frequently such pedometers were difficult to read and difficult to reset. For the most part, the prior art pedometers were intended to be accurate instruments for adult use and were not intended for use as a child's toy.

The present invention is directed to a pedometer toy for use by children. The structure is unique in that it avoids all use of springs which are expensive and unreliable in toy-grade mechanisms. As a result, the pedometer toy lends itself well to low-cost mass production. Instead of springs, gravitational and frictional forces are used by means of a pendulum-driven mechanism.

The pendulum-driven mechanism is simple in construction, sturdy and capable of withstanding handling and use by children, while at the same time yielding reasonable accuracy. Finally, the pedometer toy of the present invention is readily readable and resettable to zero or any other desired setting.

SUMMARY OF THE INVENTION

The pedometer toy comprises a support plate mounted in a case. The case is closed by a crystal which exposes to the view of the user one or more distance indicator means mounted on the support plate.

While, as will be explained hereinafter, the distance indicator means may be designed to give various readings, the exemplary embodiment described hereinafter is provided with a first indicator means giving a reading in feet and a second indicator means giving a reading in fractions of a mile.

The indicator means are driven by a gear train mounted on the support plate. The gear train, in turn, is advanced in appropriate increments by a pendulum carrying a pawl cooperating with a ratchet wheel.

Finally, suitable means are provided to affix the pedometer toy to the user's body. In the exemplary embodiment to be described, the case is provided with a hook-like element which may be engaged upon an appropriate part of the user's clothing such as his belt.

BRIEF DESCRIPTION OF THE DRAWINGS

FIG. 1 is a front elevational view of the pedometer toy of the present invention.

FIG. 2 is a rear elevational view of the support plate and the drive mechanism of the pedometer toy.

FIG. 3 is a cross sectional view of the support plate and drive mechanism taken along the section line 3—3 of FIG. 2 and including the case in cross section.

FIG. 5 is an elevational view of the miles indicator dial.

DESCRIPTION OF THE PREFERRED EMBODIMENTS

In all of the Figures, like parts have been given like index numerals. Turning first to FIGS. 1, 3 and 4, the pedometer case is generally indicated at 1. While the shape of the case does not constitute a limitation on the present invention, the exemplary embodiment is illustrated as being circular and comprising a rear wall 2 and an annular side wall 3.

The manner in which the pedometer is affixable to the wearer's body does not constitute a limitation on the present invention. For purposes of an exemplary showing, at the top of the pedometer case, the annular side wall 3 is shown as having a hollow cylindrical stem 4. The hollow stem 4 is adapted to receive the shank 5 of a rectangular ring-like structure 6. The ring 6 and stem 5 are rotatable in the hollow stem 4. The shank 5 is captively held in the stem 4 by an enlarged portion 7 on the ring-like structure and an enlarged or upset end 8 on the shank.

The pedometer is removably affixable to a portion of the user's clothing (such as his belt) by an attachment means 9 comprising an elongated resilient member having a hook-like configuration 10 at its lower end engaging the ring-like structure 6. At its upper end, the attachment means 9 has another hook-like configuration 11 for engagement of the user's belt or the like. Thus, the pedometer case 1 is not only rotatably supported by the shank 5 of the ring-like structure 6, but also the ring-like structure 6 is swingable in the lower hook 10 of the attachment means 9.

As is most clearly shown in FIGS. 3 and 4, the forwardmost end of case side wall 3 has formed therein a pair of annular shoulders 12 and 13. A disc-like support plate 14 (to be described hereinafter) is located on the shoulder 12. The case is completed by a crystal 15 of clear plastic or the like. The crystal 15 has a forward face 16 and an annular side wall or flange 17, the end of which rests upon the annular shoulder 13 of the case 1. The crystal may be so sized as to have a snap engagement with the case 1 or it may be permanently affixed thereto by glue or the like. It will be noted that the crystal is of such thickness as to partially overlap the peripheral edge of the support plate 14, holding the support plate in place.

While the material from which the pedometer case is made does not constitute a limitation on the present invention, it will be readily understood that all of the structure thus far described, including the case, the ring-like structure and attachment means, the support plate and the crystal may be easily and inexpensively molded of plastic or the like.

The disc-like support plate 14 has a forward face or surface 14a and a rearward face or surface 14b. The support plate has a first opening therein generally indicated at 18. The opening 18 has an elongated narrow portion 18a with an enlarged upper portion 18b and an enlarged lower portion 18c. On either side of the enlarged upper portion 18b of opening 18 the rearward surface 14b of the support plate has a pair of integral, rearwardly extending lugs 19 and 20. The lugs 19 and

As is most clearly shown in FIGS. 1, 2 and 4, a pendulum 22 is provided comprising an elongated shank 22a surmounted by an integral disc-like portion 22b and provided at its bottom end with a weight 22c. The disc-like portion is pivotally mounted on shaft 21. Adjacent the disc-like portion of the pendulum a ratchet wheel 23 and a pinion 24 are also rotatively mounted on the shaft 21. The ratchet wheel 23 and the pinion 24 are intended to rotate together and may constitute an integral, one-piece structure. A pawl 25, adapted to cooperate with ratchet wheel 23, is pivotally affixed to the disc-like portion 22b of the pendulum by a pin 26.

From the structure thus far described, it will be understood that the enlarged upper portion 18b of the opening 18 in the support plate is adapted to accommodate the disc-like portion 22b of the pendulum, as well as the ratchet wheel 23, pinion 24 and pawl 25. The elongated portion 18a of the opening 18 accommodates the shank 22a of the pendulum, while the lower enlarged portion 18c of the opening 18 accommodates the pendulum weight 22c.

The pendulum is swingable on the shaft 21 and, as will be evident from FIGS. 1 and 4, the forward swing of the pendulum through the opening 18 in the support plate will be limited by an integral strap 27 formed on the forward face 14a of the support plate 14. The strap 27 spans the elongated portion 18a of the opening 18 and acts as a forward abutment for the shank portion 22a of the pendulum. The rearward limit of swing of the pendulum is determined by abutment of the weight 22c of the pendulum and the inside surface of the case wall 2.

The purpose of ratchet wheel 23 and pawl 25 is to translate the swinging motion of pendulum 22 into incremental rotational movement. Thus, as the pendulum swings forwardly, i.e., to the left in FIG. 4, the pawl 25 will slide over the teeth of ratchet wheel 23. Upon rearward movement of the pendulum (i.e., to the right in FIG. 4) the pawl will engage the teeth of the ratchet wheel and impart to it an increment of counterclockwise rotation (as viewed in FIG. 4). As indicated above, the pinion 24 will rotate with the ratchet wheel 23.

Referring to FIG. 3, it will be noted that the integral lug 20 on the rear face of support plate 14 has a perforation 28 therein. The perforation 28 is adapted to receive the splined end 29a of a shaft 29 with a force fit. The rear wall 2 of the case 1 may have a relief or depression 30 therein to assure proper clearance for the headed end 29b of shaft 29.

Rotatively mounted on shaft 29 is a crown gear 31 and pinion 32. The crown gear 31 and pinion 32 are intended to rotate together and may comprise an integral, one-piece structure. The teeth of the crown gear mesh with the teeth of pinion 24 so that the incremental rotation of ratchet wheel 23 and pinion 24 will cause incremental rotation of the crown gear 31 and pinion 32 in a clockwise direction, as seen in FIG. 2.

The support plate 14 has a centrally located boss 33 extending rearwardly of its rear surface 14b and forwardly of its forward surface 14a. The boss 33 has an axial perforation 34. Rotatively mounted in the perforation 34 is a shaft 35. The forward end of shaft 35 is

the reset knob 38 extends through a central perforation 39 in the crystal 15.

Non-rotatively affixed to the rear end of shaft 35 is a spur gear 40 and a pinion 41. The spur gear 40 and pinion 41 may again comprise an integral one-piece structure. The teeth of spur gear 40 are intended to mesh with the teeth of pinion 32.

From FIG. 2 it will be evident that the incremental clockwise motion of crown gear 31 and pinion 32 will cause an incremental rotation of spur gear 40 and pinion 41 in a counterclockwise direction. Since the spur gear 40 and pinion 41 are non-rotatively affixed to shaft 35, their rotation will be imparted to the shaft 35 and the hand 37. As viewed in FIG. 1, the hand 37 will rotate in a clockwise direction. As is further shown in FIG. 1, the forward face 16 of the crystal 15 has thereon indicia, graduated in feet, from 0 to 500. As is well known in the art, the size and number of teeth of the ratchet wheel 23 and the remaining gear train thus far described will be so chosen as to cause the hand 37 to give a reasonably accurate reading of the feet traversed. Since the pedometer of the present invention is particularly adapted for use as a child's toy, the gear train may be so selected as to give an accurate reading on the basis of the average stride length of a child within a given age group.

Returning to FIG. 3, the rear surface 14b of the support plate 14 has an integral, rearwardly extending shaft 42 thereon. Rotatively mounted on the shaft 42 is a spur gear or "miles wheel" 43. The free end of shaft 42 may be upset to assure that the spur gear 43 will remain in place. The teeth of spur gear 43 are intended to mesh with those of pinion 41 so that (as seen in FIG. 2) incremental rotation of spur gear 40 and pinion 41 will impart incremental rotation of spur gear 43 in a clockwise direction.

The forward surface of spur gear or miles wheel 43 may have a "miles dial" affixed thereto. This is illustrated in FIG. 5. The miles dial 44 is affixed to the spur gear 43 by any suitable means such as gluing or the like. It will be noted that the miles dial is graduated in tenths of a mile from 0 miles to one-half mile.

As is shown in FIG. 1, the support plate 14 has an opening 45 therein through which a portion of the miles dial may be viewed. In order to facilitate the reading, the opening 45 may be so configured as to have indicator points 46 and 47. It will be understood that the miles wheel or spur gear 43 will be so chosen as to have an appropriate diameter and number of teeth to give a reasonably accurate miles reading.

Finally, the support plate 14 may have an additional opening 48 through which a portion of the gear train may be viewed.

The operation of the pedometer toy of the present invention is as follows. The user affixes the pedometer toy to an appropriate portion of his clothing, such as his belt, by attachment means 9. With each stride, the motion of the user's body will cause the pendulum 22 to swing. The swinging motion of the pendulum will, through the agency of ratchet wheel 23, pawl 25 and pinion 24 impart an incremental rotational movement to crown gear 31 and pinion 32. Pinion 32, in turn, will drive spur gear 40, resulting in clockwise rotation of hand 37 (as viewed in FIG. 1). The hand 37 will give a rea-

Explore Litigation Insights

Docket Alarm provides insights to develop a more informed litigation strategy and the peace of mind of knowing you're on top of things.

Real-Time Litigation Alerts



Keep your litigation team up-to-date with **real-time alerts** and advanced team management tools built for the enterprise, all while greatly reducing PACER spend.

Our comprehensive service means we can handle Federal, State, and Administrative courts across the country.

Advanced Docket Research



With over 230 million records, Docket Alarm's cloud-native docket research platform finds what other services can't. Coverage includes Federal, State, plus PTAB, TTAB, ITC and NLRB decisions, all in one place.

Identify arguments that have been successful in the past with full text, pinpoint searching. Link to case law cited within any court document via Fastcase.

Analytics At Your Fingertips



Learn what happened the last time a particular judge, opposing counsel or company faced cases similar to yours.

Advanced out-of-the-box PTAB and TTAB analytics are always at your fingertips.

API

Docket Alarm offers a powerful API (application programming interface) to developers that want to integrate case filings into their apps.

LAW FIRMS

Build custom dashboards for your attorneys and clients with live data direct from the court.

Automate many repetitive legal tasks like conflict checks, document management, and marketing.

FINANCIAL INSTITUTIONS

Litigation and bankruptcy checks for companies and debtors.

E-DISCOVERY AND LEGAL VENDORS

Sync your system to PACER to automate legal marketing.