

- [54] HIGH ACCURACY PEDOMETER AND CALIBRATION METHOD
- [75] Inventors: William R. Sutton, 4898 Dolores Dr., Pleasanton, Calif. 94566; Scott L. Noble, San Jose, Calif.
- [73] Assignee: W. Ron Sutton, Pleasanton, Calif.
- [21] Appl. No.: 559,076
- [22] Filed: Jul. 30, 1990
- [51] Int. Cl.⁵ G01C 22/00
- [52] U.S. Cl. 377/24.2; 364/561; 377/26
- [58] Field of Search 377/24.1, 24.2, 26, 377/5; 364/561, 566

FOREIGN PATENT DOCUMENTS

- 0219407 12/1983 Japan 377/24.2
- 0079197 4/1988 Japan 377/24.2

Primary Examiner—John S. Heyman
Attorney, Agent, or Firm—Richard B. Main

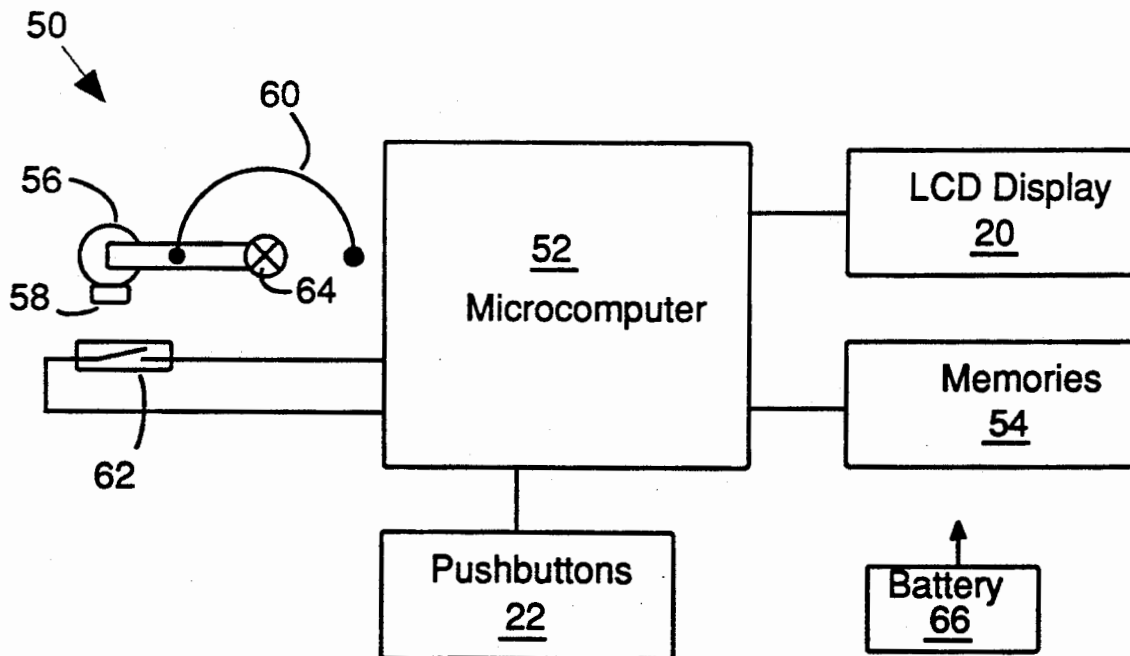
[57] ABSTRACT

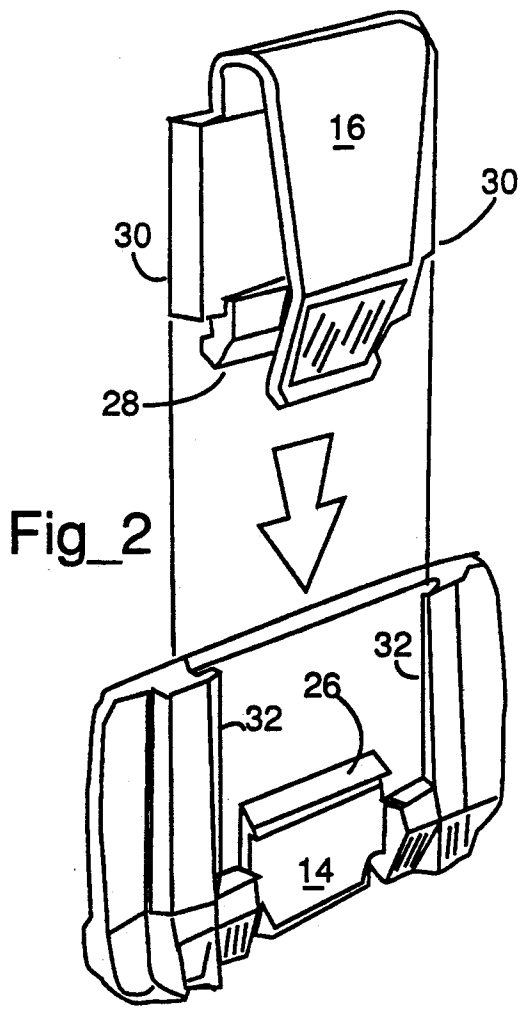
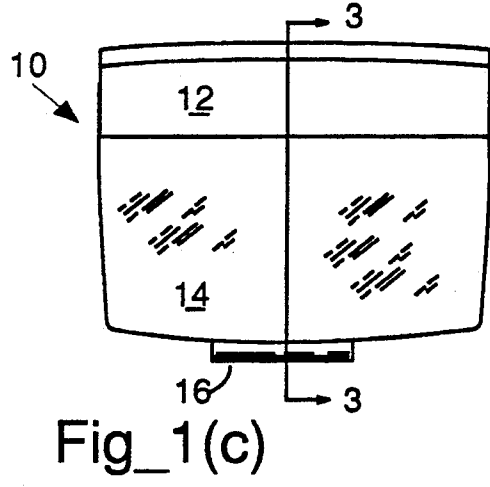
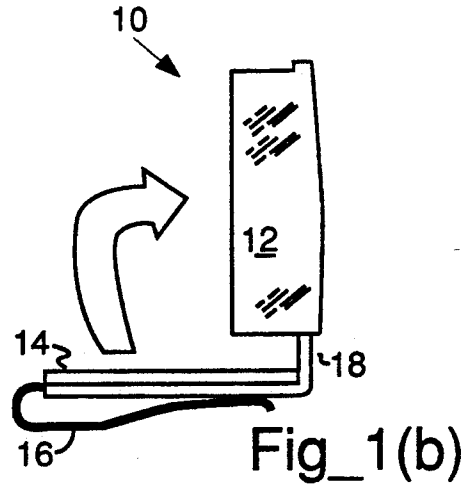
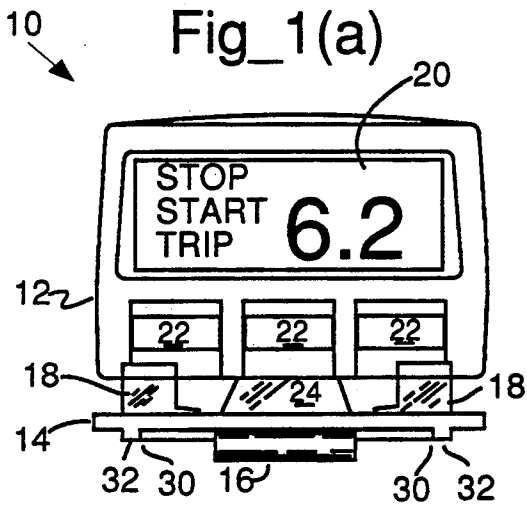
A preferred embodiment of the present invention comprises a pedometer having a housing, a weighted pendulum, a magnet and reed switch, a microprocessor, a LCD display, three push-buttons, a hinged door with a spring cam device that holds the door open and shut, and a replaceable belt hook. The entire unit is powered by an oversized lithium battery that has an expected life of seven years. A unique method of user calibration simplifies user input and provides maximum calibration accuracy regardless of operational or stride artifact variations.

[56] References Cited
U.S. PATENT DOCUMENTS

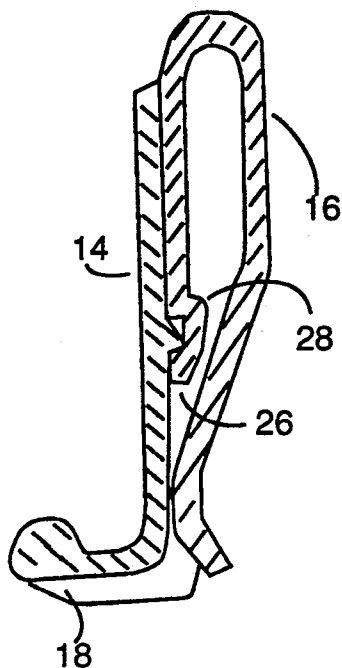
- 4,223,211 9/1980 Allsen et al. 377/24.2
- 4,387,437 6/1983 Lowrey et al. 364/561
- 4,741,001 4/1988 Ma 377/24.2
- 4,821,218 4/1989 Potsch 364/566

17 Claims, 3 Drawing Sheets

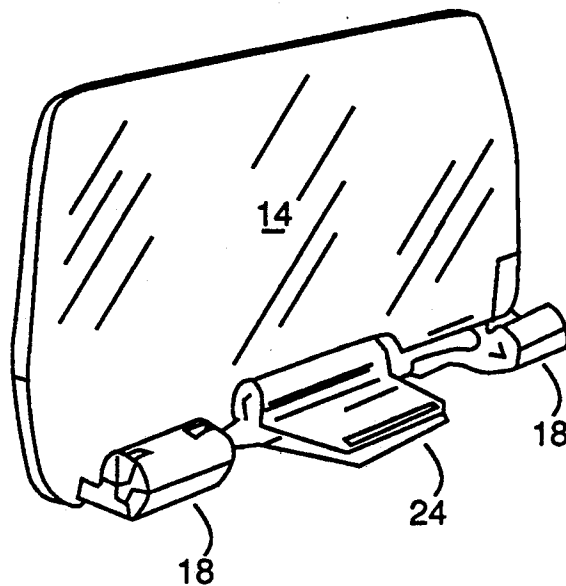




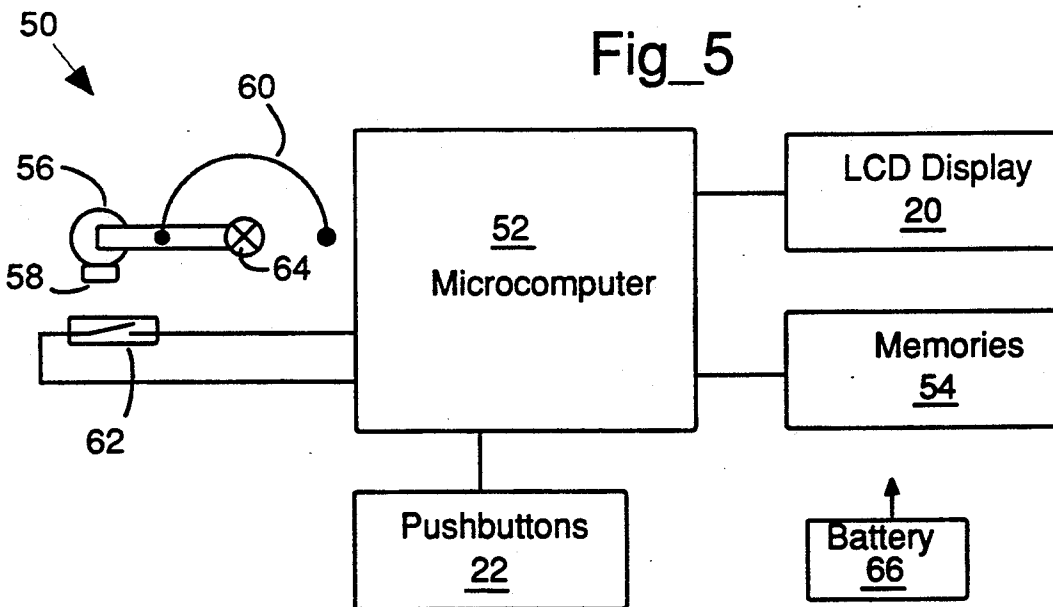
Fig_3



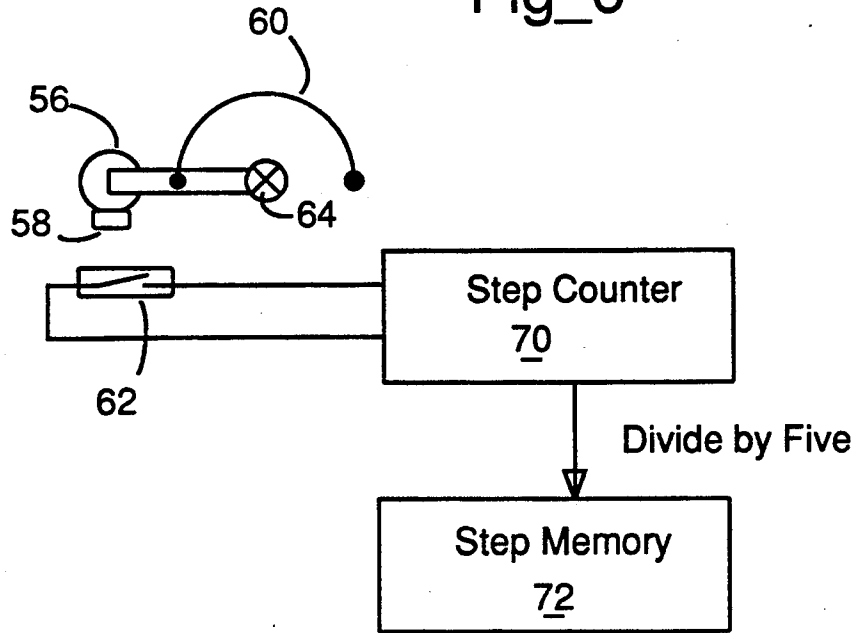
Fig_4



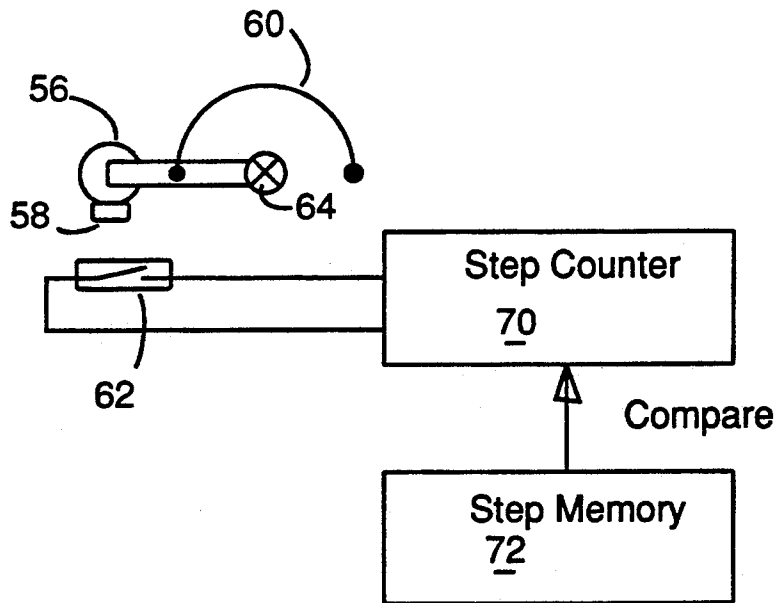
Fig_5



Fig_6



Fig_7



HIGH ACCURACY Pedometer AND CALIBRATION METHOD

BACKGROUND OF THE INVENTION

1. Field of the Invention

The invention relates generally to pedometers and specifically to electronic-type multi-event capable devices for the measurement of traveled distances or other activity based on oscillations of position within or outside a gravity field.

2. Description of the Prior Art

Pedometers primarily measure the distance walked or run by a human wearer of the device by virtue of the up and down motion made by the wearer during each stride. Pedometers have also been attached to farm animals to measure physical activity. The distance traveled by a user of a pedometer is the length of the user's stride times the number of strides the user takes. Typical pedometers employ a weighted pendulum suspended horizontally from an axis by a spring. The inertia of the pendulum's weight will cause the pendulum to move in relation to the pedometer each time the wearer takes a stride. The more repeatable a user's activity is from event to event, the more accurate will be the resulting measurement. It is possible for pedometers to measure many other kinds of activity besides walking or running, including mathematical conversion of data to "points" or "indices," not directly related to distance, e.g., aerobic points for playing tennis.

The prior art comprises two ways of detecting the movement of the pendulum, (1) mechanically, and (2) electrically. In mechanical detection pedometers, a disk with teeth around its circumference is attached by a ratchet to the pendulum. (See, U.S. Pat. No. 4,560,861, issued to Kato, et al., on Dec. 24, 1985; and see U.S. Pat. No. 4,322,609, issued to Kato on Mar. 30, 1982.) Each stride causes the ratchet to advance by one or more teeth positions. The length of arc the pendulum is allowed to swing is controlled by adjustable stops. A wide setting, stop-to-stop, sets the pedometer for a long stride, such as in running. A narrow setting is used typically for strolling. The resolution of such pedometers is limited by the distance represented by the arc distance between adjacent teeth on the toothed disk. The resolution is often no greater than one-quarter to one-half foot. In a mile, that can lead to resolution inaccuracies as much as ± 250 to ± 500 feet.

Electrically instrumented pedometers mimic their mechanical counterparts. In electrical pedometers the weighted pendulum is outfitted with a switch contact that will close each time the pendulum completes a swing. Ordinary switches, however, are prone to intermittent operation and a full swing against the balance spring must be made to ensure contact. Running will subject the weighted pendulum to as much as three G's, and will probably result in good switch contact. But to enable operation during walking, which can produce as little as 0.5 G's, the balance spring must be made very light. Too light a balance spring will allow the weighted pendulum to swing violently, and can cause false readings. The prior art controls balance spring tension with an adjustment. Many manufacturers have only a two-point adjustment, "walk" and "run", and a few others have continuously adjustable balance spring tensioners (e.g., Yamasa Tokei Meter Co., Ltd., Japan). A large proportion of patents dealing with the prior art are addressed to the problem of controlling balance spring

tension. Improved switching in the prior art has been realized by mounting a small permanent magnet to a pendulum made of brass and by placing a reed switch at the outside point of the pendulum's arc. The reed switch has contacts maintained under glass seal, and the magnet on the pendulum need only get close to establish contact. Reed switch pedometers are much more reliable and give fewer false readings than other prior art devices. A Casio mathematical cadence device uses a time-based method, instead of a stride detector. In the time-based method, a user is expected to take a standard length stride each time the device beeps. If the user fails to take a stride, and the device beeps, the Casio device will nevertheless assume a step was taken. A failure by the user to stay in step with the cadence is therefore a major source of error in the Casio pedometer.

Invariably the prior art makes some assumptions about the length of strides taken by the user. A user must enter a stride length into the pedometer, and that length will be used in the future calculations of the distance traveled. These stride estimates are a source of great inaccuracy, because the user may only be guessing at the length of his or her stride, or the estimate of a stride is based on a small, artificial sample. In addition, strides can vary. Artifacts of a user's walk or run can also vary over a few strides, and artifacts of the pedometer's operation can also vary, especially in interaction with different users. A pedometer placed on a user's wrist, as opposed to a user's belt, would generate so many unusual artifacts of motion, that all prior art pedometers would not be able to function with any acceptable accuracy. In addition, the stride resolution of prior art pedometers, as mentioned above, can contribute to inaccurate measurements. And given the small sizes of mechanical pedometers, dialing in the correct stride length can be very difficult. A pedometer that simplifies stride calculation, or eliminates it altogether would be an improvement over the prior art.

Prior art pedometers, generally, cannot be turned on or off. Even electrically instrumented pedometers measure all the time. In addition, none have the ability to store information in multiple registers, and none can track multiple events. An example of a useful multi-event function would be a user's goal to walk 20 miles during five consecutive lunch hours during the week. Event number one would be Monday's walk, event number two would be Tuesday's walk, and so on to event number five being Friday's walk. A sixth event could be the running total walked for the week. Prior art devices could only deal with one of these events, and a user would have to select which one by starting and stopping around the event of interest. Such starting and stopping would clear any previous results, because there is no memory in any of the prior art pedometers. A user would either have to give up knowing the daily totals or the weekly total. Since there is no "off," a user would also have to make a separate record for later reference at the end of the event of interest, because the pedometer will continue to advance with any further physical activity whether related to the particular event or not.

Housings for prior art pedometers and their associated knobs and displays require a user to detach the pedometer from a belt hook or shoe and to bring it close enough to the user's face to see the small numbers, or to open it in such a manner that significant false readings may occur. Such action can jiggle the device and cause

Explore Litigation Insights

Docket Alarm provides insights to develop a more informed litigation strategy and the peace of mind of knowing you're on top of things.

Real-Time Litigation Alerts



Keep your litigation team up-to-date with **real-time alerts** and advanced team management tools built for the enterprise, all while greatly reducing PACER spend.

Our comprehensive service means we can handle Federal, State, and Administrative courts across the country.

Advanced Docket Research



With over 230 million records, Docket Alarm's cloud-native docket research platform finds what other services can't. Coverage includes Federal, State, plus PTAB, TTAB, ITC and NLRB decisions, all in one place.

Identify arguments that have been successful in the past with full text, pinpoint searching. Link to case law cited within any court document via Fastcase.

Analytics At Your Fingertips



Learn what happened the last time a particular judge, opposing counsel or company faced cases similar to yours.

Advanced out-of-the-box PTAB and TTAB analytics are always at your fingertips.

API

Docket Alarm offers a powerful API (application programming interface) to developers that want to integrate case filings into their apps.

LAW FIRMS

Build custom dashboards for your attorneys and clients with live data direct from the court.

Automate many repetitive legal tasks like conflict checks, document management, and marketing.

FINANCIAL INSTITUTIONS

Litigation and bankruptcy checks for companies and debtors.

E-DISCOVERY AND LEGAL VENDORS

Sync your system to PACER to automate legal marketing.