

W. E. PORTER.  
PEDOMETER.

APPLICATION FILED APR. 23, 1902.

NO MODEL.

2 SHEETS—SHEET 1.

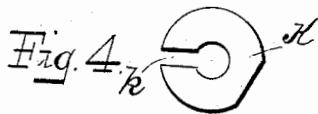
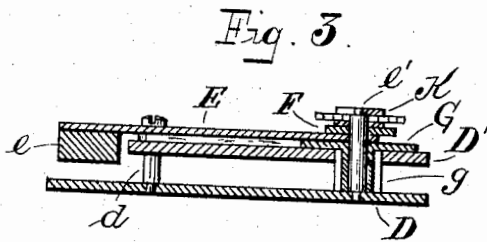
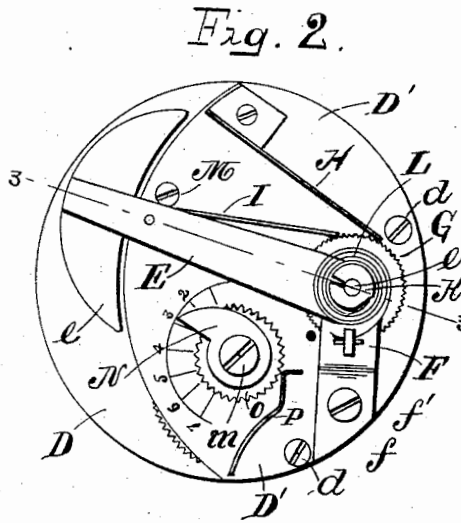
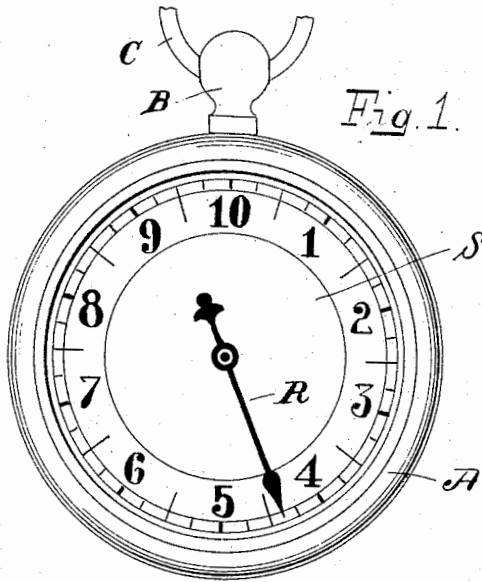

WITNESSES:

*J. Coleman*  
*William R. Pothin*

INVENTOR

*Wesley E. Porter*  
BY *Beach & Fisher*  
ATTORNEYS.

W. E. PORTER.  
PEDOMETER.

APPLICATION FILED APR. 22, 1902.

NO MODEL.

2 SHEETS—SHEET 2.

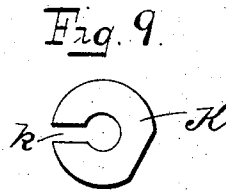
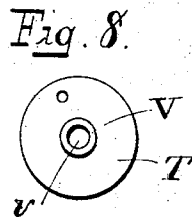
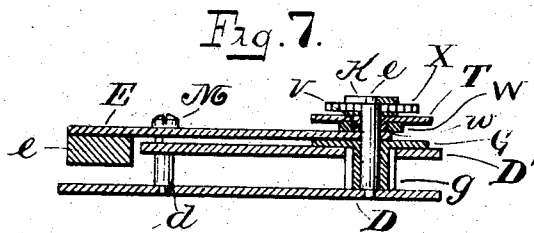
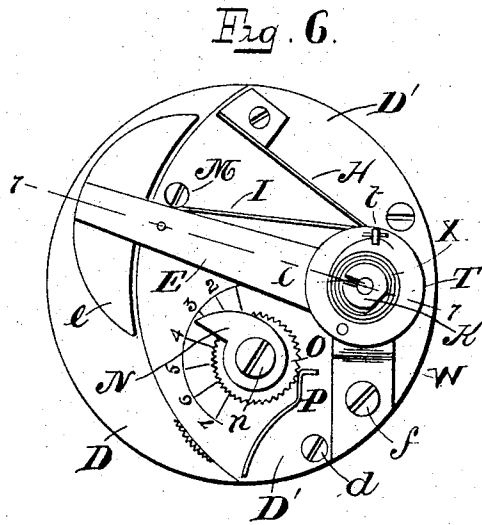
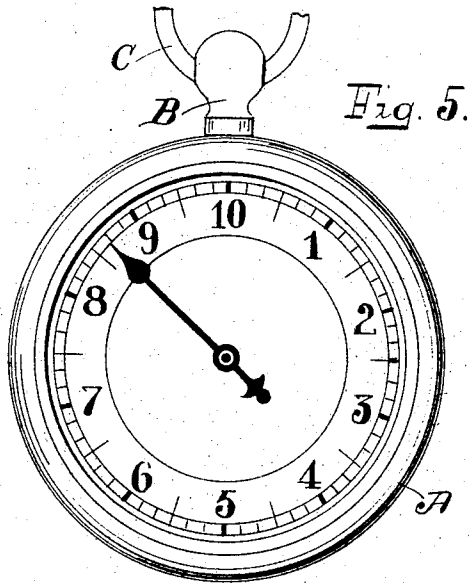

WITNESSES:

*J. Coleman*  
*William R. Patkin*

INVENTOR

*Wilson E. Porter*  
BY *Beach & Fisher*  
ATTORNEYS.

# UNITED STATES PATENT OFFICE.

WILSON E. PORTER, OF NEW HAVEN, CONNECTICUT.

## PEDOMETER.

SPECIFICATION forming part of Letters Patent No. 765,992, dated July 26, 1904.

Application filed April 22, 1902. Serial No. 104,125. (No model.)

*To all whom it may concern:*

Be it known that I, WILSON E. PORTER, of the city and county of New Haven, State of Connecticut, have invented a new and useful  
 5 Improvement in Pedometers, of which the following is a full, clear, and exact description when taken in connection with the accompanying drawings, which form a part of this specification, and in which—

10 Figure 1 represents a front view of a pedometer embodying my invention; Fig. 2, a reverse view with the case removed; Fig. 3, a vertical section through lines 3 3 of Fig. 2; Fig. 4, a top view in detail of the washer carrying one end of the mainspring; Figs. 5, 6,  
 15 and 7, views of a modification of my device corresponding, respectively, to Figs. 1, 2, and 3; Fig. 8, a bottom view of one of the washers carrying one end of the mainspring; and  
 20 Fig. 9, a top view of the washer carrying the other end, as illustrated in the modification shown in Figs. 5 and 7.

In all figures similar letters of reference represent like parts.

25 My invention relates to pedometers or devices for registering the distance traveled by a pedestrian carrying the same, and has for its object the production of a novel, simple, and efficient construction embodying the various improvements and combinations of parts  
 30 set forth hereinafter.

Referring to the drawings for a more particular description, the letter A designates the case, B the stem, and C the ring attached  
 35 thereto by which the pedometer may be suspended.

D and D' represent the plates adapted to be secured in any suitable manner to the case and upon which the movement is mounted.

40 *d* represents pillars holding the plates in their proper relation with each other.

E represents a lever carrying a weight *e* at one end and rigidly connected to a post *e'* at the other end, the latter having journal-bearings in the plates D and in a bridge F, mounted  
 45 on and secured to the plate D' by a screw *f'* or other suitable means.

Loosely mounted on the post *e'* beneath the lever E is a ratchet G, connected to a pinion  
 50 *g*, located between the plates D and D'. Two

spring-pawls H and I, both of which engage the ratchet-wheel G, are secured, respectively, to the plate D' and the lever E.

A washer K, which may be formed, as shown, slotted at *k*, is fitted on the post *e'*, where it  
 55 is held by a frictional contact alone to normally rotate with the post. A spring L is coiled about the post and has one end secured to a lug *f'* on the bridge F and the other end  
 60 secured by any suitable means to the washer K. The washer K, having a merely frictional connection with the post *e'*, may upon the application of sufficient force be turned on the post, so that the tension of the spring L may  
 65 be adjusted to the proper nicety. Normally the tension should be sufficient to retain the weighted lever in its raised position (shown in Fig. 2) against the stop M on the plate D'. Upon any jar of the pedometer, as in the step  
 70 of the pedestrian carrying it, the weight of the lever overcomes for a moment the tension of the spring and forces the lever down against a secondary stop N, from which point the spring will return it to its normal position. The stop N is in the form of a cam and is  
 75 mounted on a post N and rotatable thereon. A gear O is also mounted on the post *n* to rotate with the cam, and a spring-catch P, secured to the plate D', engages the gear to hold it in any desired position and until sufficient  
 80 force is exerted to overcome the engagement of the catch. This secondary stop N and its associated parts are of substantially the construction shown and described in United States Patent No. 694,652, granted March 4, 1902,  
 85 to Edmond Kuhn, assignor to the American Pedometer Company, and therefore needs no detailed description. Upon the movement down and up of the lever E the ratchet-wheel G will be rotated by the pawl I and held from  
 90 reverse rotation by the pawl H. The movement of the ratchet-wheel G is communicated through the pinion *g* by a train of gears, (not shown,) which may be of any suitable construction, to an indicator or hand R, which  
 95 travels around a dial S on the case A of the pedometer.

In the modification shown in Figs. 5 to 9 the parts are the same except that one end of the spring is not secured directly to the bridge  
 100

IPR2017-01058

W; but a disk T is provided with a downwardly-projecting sleeve V, having an axial perforation *v*, adapted to fit loosely over the post *s* and enter a circular perforation in the bridge W. This sleeve is adapted to fit so nicely in the bridge W that it is normally held rigidly thereto by frictional contact, but may upon the exertion of sufficient force or pressure be turned therein. The spring X is connected to the washer K at one end and to a lug or post *t* on the disk T. By this means either or both ends of the spring are adjustable, the one in relation to the lever and the other in relation to the bridge.

The spring should be adjusted so that it will permit the jar of the step of the pedestrian to throw the weighted end of the lever downward to its full limit and then return it to its normal position, for if the lever fails to make its complete movement between the two steps the ratchet-wheel will not be turned the proper distance to accurately register the distance traveled. As the steps of various people vary and the length of the movement of the lever is changeable at will, the possibility of adjusting the spring is essential. Moreover, by the constant jarring given to the pedometer, and consequently to the spring connected to the lever, the spring is apt to be worn or lose its nice adjustment, which prevents the correct operation of the pedometer. By means of my improvement the spring may be readily and correctly adjusted at any time for either of these reasons without removing any of the parts.

Having now described my invention, which may vary somewhat in its details without departing from the spirit thereof, what I claim, and desire to secure by Letters Patent, is—

1. In a pedometer, the combination with a frame, of a weighted vibratory lever, a rotary post mounted on said frame and rigidly secured to said lever, stops for limiting the movement of said lever in both directions, registering mechanism operated by the movement of said lever, a washer having frictional engagement with said post, a spring connected with said frame, and washer, and tending to normally hold said lever against one of said stops, said spring being adjustable to permit said lever to vibrate between both of said stops, substantially as described.

2. In a pedometer, the combination with a frame, of a weighted vibratory lever, a rotary post mounted on said frame and rigidly secured to said lever, a stop for limiting the movement of said lever in one direction, a registering-train operated by the movement of said lever, a washer having a frictional connection with said post, and a spring secured to said washer and adjustably connected to said frame, tending normally to hold said lever against said stop, substantially as described.

In witness whereof I have hereunto set my hand on the 18th day of April, 1902.

WILSON E. PORTER.

Witnesses:

EUGENE CARTIER,  
BEULAH RUSSELL.