

(19) Japanese Patent Office (JP)

(12) **Unexamined Patent Application Bulletin (A)**

(11) Laid Open Patent Application No. **5-42853**

(43) **Publication Date** February 23, 1993

(51) Int. Cl. ⁵	Identification Code	Internal File No.	FI	Tech. Indic.
B60R 11/02	C	9144-3D		
H04N 5/64	521 F	7205-5C		
	581 C	7205-5C		

Examination Request: not yet made **Number of Claims:** 4 (Total 10 pages)

(21) Application No.:	3-200250	(71) Applicant:	000005108 Hitachi, Ltd. 4-6 Surugadai, Kanda, Chiyoda-ku, Tokyo-to
(22) Application Date:	August 9, 1991	(72) Inventor:	YAMADA, Yuuichi Hitachi, Ltd. Yokohama plant 292 Yoshidacho, Totsuka-ku, Yokohama-shi, Kanagawa-ken
		(72) Inventor:	MAKIMOTO, Shinjiro Hitachi, Ltd. Yokohama plant 292 Yoshidacho, Totsuka-ku, Yokohama-shi, Kanagawa-ken
		(74) Agent:	Patent Attorney, OGAWA, Masao

(54) **Title of the Invention: SCREEN SUPPORT DEVICE**

(57) **[Abstract]**

[Object] To immobilize a television or monitor screen, having a screen turning axis, against external vibrations, so as to improve usability, and to prevent the transmission of stress, resulting from screen turning operations or the aforementioned external vibrations, to the surface of the liquid crystal panel, so as to greatly improve the MTBF (mean time between failures) of the television or monitor.

[Configuration] A first rotary shaft 8 of a turning body 22 is engaged so as to be able to move in the axial direction with a first rotary shaft 9 [sic] provided in a frame 2; a second rotary shaft 10 [sic] is provided on a turning radius of the first rotary shaft 8; members that are pressed, from both the left and right sides, by a plurality of pressure washers 14, a braking boss 11, which passes through a tilt plate 6, and the second rotary shaft 10 are engaged so as to allow movement in the axial direction; and a screen 5 is immobilized by a braking force against the turning direction when the turning body 22 is turned around the first rotary shaft 8.

FIG. 2

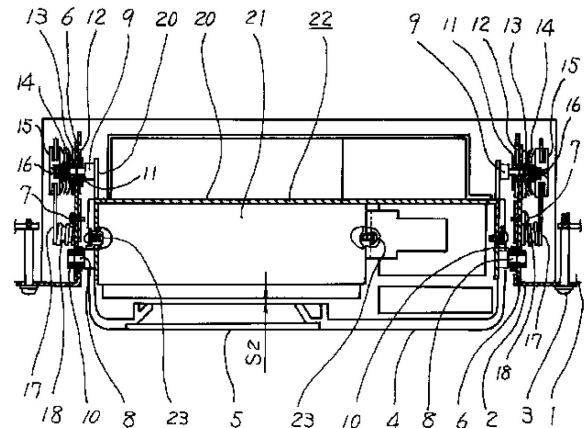

[Claims]

[Claim 1] In a television system, or a monitor system, which is mounted in a traveling body such as a railway car or a bus, in which video and audio signals transmitted from input equipment, [such as] a receiver, distributor, modulator, video [player], amplifier, and mixer, is output on the image display unit or on the headphone speakers of a television or monitor fastened to a seat or a wall (hereafter, the television system or monitor system is referred to, abbreviated, as the television), a screen support device characterized in that: with a television body that includes the image display unit, wherein an axis parallel to the horizontal direction of the television image display screen serves as the center of rotation, first rotary shafts are provided at the left and right side faces of the television body, and allow the image display unit to turn in the forward and rearward directions with respect to a fastening part on a seat or a wall in the traveling body; on these same sides, second rotary shafts are provided on a radius that turns around the first rotary shaft; a left and right pair of first rotary bearings are provided in the side faces of a frame that is fastened to the seat or wall, which face the left and right side faces of the television body, and which engage the first rotary shafts so as to allow movement in the axial direction and allow turning; plates that are provided with a groove on a trajectory along which the second rotary shaft turns around the first rotary shaft, on a radius thereof, are fastened to the frame; a braking boss is passed through this groove; a braking washer is provided, with the braking boss passing therethrough, on both sides or on one side of the braking boss, and makes contact with the face of the plate in the vicinity of the groove; furthermore, the braking boss passes through the washer so that pressure is applied by a [wave] spring or a coil spring; a stopper is provided on the braking boss, which regulates the amount of elastic deformation of the [wave] spring or coil spring; the braking washer and the plate are brought into pressing contact; and when the television body is turned around the first rotary shaft, engaged on the braking boss so as to allow movement in the axial direction and allow turning with the second rotary shaft provided on the television body, a braking force is applied by way of the surface contact between the plate and the braking washers, which are pressed by the [wave] spring or coil spring, so as to turn and immobilize the television body.

[Claim 2] A screen support device characterized in that, in claim 1, the periphery of the television body is engaged surrounded by a metal case, and the first rotary shafts and the second rotary shafts are provided at the left and right side faces of the metal case.

[Claim 3] A screen support device characterized in that, in the device of claim 1 or 2, resistance is applied to the braking boss, by a spring, in a direction that resists the gravitational force of the television body, so as to resist the gravitational force of the television body and cause the turning force resulting from the gravitational force to approach zero.

[Claim 4] A screen support device characterized in that, in the device in claim 1, 2 or 3, a plastic case is fixedly engaged with metal that surrounds the periphery of the television body, with a gap provided with respect to the liquid crystal panel of the television body.

[Detailed Description of the Invention]**[0001]**

[Field of Industrial Application] The present invention relates to a mechanism for a device, which resists external vibration during travel so as to immobilize and support a turnable television, or image display unit of a display, which is mounted on a seat, a wall or the like, in a traveling body such as a railway car or a bus.

[0002]

[Prior Art] Conventional televisions, or image display units of displays (hereafter, image display units are referred to

of seats in railway cars, buses or the like, were such that the screen was configured in a manner such that controlling force was applied, in a turning direction, to a rotary shaft in a fastening part in the back face of a seat, so that it was possible to turn the screen in the vertical direction, so as to allow viewing in a position that is easily viewed by a person, and the screen could be immobilized, resisting vibrations during travel.

[0003] An example of a device having a structure of this type will be described, referring to the drawings.

[0004] FIGS. 14 and 15 show front views, including partial sectional views, of the situation in which this is mounted on a back face of seat in a bus or a railway car; in FIG. 14, 101 indicates a seat; 102 indicates a frame; 103 indicates a case that houses a television; 104 indicates a rotary shaft, which is a riveted rivet; 105 indicates a braking member having viscoelastic properties, made from a material such as rubber; and 106 indicates the screen of a television or monitor.

[0005] In this figure, the bottom of the case 103 turns around the rotary shaft 104, as a result of being pulled up by a person's hand, while being subjected to braking force, which is to say resistance, caused by the side face of the frame 102 and the side face of the case 103, on the braking member 105.

[0006] Next, in FIG. 15, components that are the same as in the previous figure are given the same reference numerals, in addition to which, 107 indicates a casing made from metal, the case 103 being fastened in the casing 107, and the case 103 and the casing 107 can be turned around the rotary shaft 104 by a person's hand, with respect to the frame 102, in the same manner as in FIG. 14 described above.

[0007] Furthermore, as an example of a device, which is not for vehicle mounted use such as shown in FIGS. 14 and 15, but rather is mounted in an ordinary household, and which allows for turning and immobilization of the screen of a mountable television, "Designer Televisions Intended for Living Spaces," "4. Tilt Mechanisms" appearing on pages 17 and 18 of NEC Technology, Vol. 43, No. 9, 1990, can be cited.

[0008]

[Problems to Be Solved by the Invention] A first problem with the conventional example in FIG. 14 is that, due to the creep characteristics of the viscoelastic member 105, which applies the braking force for immobilizing the case 103 that is turned to the front, by way of compressing the viscoelastic member 105 with the side face of the frame 102 and the side face of the case 103, the effect of the braking force is weakened with the passage of time, such that the braking ceases to work, due to vibrations during travel, and the screen ends up turning.

[0009] A second problem is that, if the case 103 is a member that is plastically deformed by weak forces, such as one made from plastic, the case 103 will warp when the rivet 104 is riveted, or the case 103 will warp when the bottom of the case 103 is held and the screen 106 is turned with respect to the frame 102, overcoming the aforementioned braking force, and the warp will be transmitted to the screen 106, which is fixedly engaged in the case 103, such that contact problems will occur at soldiering surfaces where the screen 106 is connected, and problems will occur in the image, with vertical lines and the like being produced on the screen 106.

[0010] A third problem is that, in order to immobilize the screen 106 at an arbitrary easily viewed position, the magnitude of the braking force with respect to the strength of the vibrations during travel, must be established with a one-to-one correspondence to the turning force of the gravitational force of the television unit comprising the case 103 and the screen 106, and therefore the force that is applied with the hand to bring about the turning operation of the screen 106 will tend to be large, and thus there were problems in that, as a result, the usability was inferior.

[0011] Next, in the conventional example in FIG. 15, it is possible to improve the problems in the image, which constitute the second problem, by surrounding the case 103 of the television screen with a metal casing 107, and thus preventing warp associated with turning of the case 103 by way of the degree of stiffness of the metal, but this does not deal with the first problem of the screen moving due to vibration during travel, or the third problem of the operational force being large and the usability being [inferior].

[0012] Furthermore, in the example of the "Designer Televisions Intended for Living Spaces," a motor was used for the force that turns the screen, which necessitated the space for laying wires and for connecting mechanisms such as gears; and as this was a cathode ray tube television, there was a problem in that this could not be easily installed in a chair.

[0013] Thus, an object of the present invention is to provide a screen support device with which turnable immobilization in any position is possible, even if there is vibration due to the movement of a traveling body, which is highly reliable and has good operability, without warp being transmitted to a liquid crystal panel, as a result of the stiffness of the case being increased, and in which the screen turning force is constant.

[0014]

[Means for Solving the Problems] In order to achieve the aforementioned object, in terms of the first problem of creep in the viscoelastic member, which generates the braking force that ensures the screen immobilization function: the television is fastened housed in a case; first rotary shafts and second rotary shafts are provided at the left and right side faces of the case; a frame is provided, fixedly engaged in the back face of a seat, arranged parallel to the longitudinal direction of each of the shafts, and perpendicular to the left and right side faces of the screen, which is provided with parts that are parallel to the left and right side faces of the case; first bearings are provided in the left and right side faces of the frame, allowing rotation with the first rotary shafts that are provided on the case, and having play in the longitudinal direction of the shafts; a second rotary shaft is provided with a stopper so that a plurality of [wave] springs made from a metallic material are elastically deformed within the allowable stress in the axial direction; the second rotary shaft is inserted into a groove in a breaking plate, with which immobilization is achieved by way of the elastic force, so as to pass through the same, and engaged, with play in the axial direction, in a hole in a boss, with the surfaces in the vicinity of the groove trapped between washers on both sides; and when [the television] is turned around the first shaft, this will turn while the boss and the washers that are engaged on the second shaft produce a braking force in the turning direction by way of the force of the [wave] springs on the breaking plate.

[0015] In terms of the second problem: the case is made from a metallic material; the screen is engaged in the case, by way of an elastic material such as a spring; and a front panel is engaged on the case with a gap maintained relative to the screen.

[0016] Next, in terms of the third problem that, when one attempts to apply a braking force in the vicinity of the rotary shaft, as in the conventional example, it is necessary to establish a large braking force, such that the force for turning the screen will be large: force is applied with a spring in the direction that approximately opposes the motive force of the turning body such

shaft by the movement of the turning body in the motive force direction approaches zero.

[0017]

[Operation] The members that generate the braking force that ensures the function of immobilizing the screen are used by way of elastic deformation, within an allowable application, in the axial direction of a plurality of [wave] springs made from a metallic material, and therefore a braking force can be generated that is in accordance with the number thereof, without plastically deforming the [wave] springs; and the braking plate is trapped between washers on both sides, whereby twice the braking force can be achieved, as compared to pressing a washer on one side. As a result, the braking force will be constant for a long period of use.

[0018] Next, the operation of turning the screen is one in which a screen that is housed in a metal case is turned, and therefore the operative force will be transmitted to the metal case and [absorbed] by the stiffness of the metal case, such that warp will not be transmitted to the screen, and there will not be problems on the screen.

[0019] Next, the magnitude of the gravitational force due to shaking as a result of the vibration of the traveling body is proportional to the gravitational force of the turning body, and therefore, because the method is performed in which resistance is applied against the movement with a spring, so as to approach zero, a small braking force will suffice in order to [immobilize] the screen, such that a small operational force can also be established for turning.

[0020]

[Working Examples] One embodiment of the present invention will be described with reference to the drawings.

[0021] FIG. 1 is an external perspective view including a partial sectional view of the situation when a screen support device, which is one embodiment of the present invention, is mounted in the back of a seat, in a bus or the like.

[0022] FIG. 2 shows a schematic view, seen from above, of a section along line I-I in FIG. 1, which is a key part of the present invention; FIG. 3 shows a schematic view, seen from the direction of the arrow (A) in the drawing, of a partial section of FIG. 1, which is a key part of the present invention; and FIG. 4 shows a schematic view, seen from the direction of the arrow (B) in the drawing, of a section along line II-II in FIG. 1, which is a key part of the present invention.

[0023] In the figures; 1 indicates a bus seat; 2 indicates a front frame; 3 indicates a tightening screw; 4 indicates a front panel; 5 indicates a screen; 6 indicates a tilt plate; 7 indicates a tilt plate fastening screw; 8 indicates a first rotary shaft; 9 indicates a second rotary shaft; 10 indicates a first rotary bearing; 11 indicates a braking boss; 12 indicates a first braking washer; 13 indicates a second braking washer; 14 indicates a pressure washer; 15 indicates a pressing boss; 16 indicates a pressure washer fastening screw; 17 indicates a U-shaped balance spring; 18 indicates a spring boss that fastens a coil part of the U-shaped balance spring; 19 indicates a spring-bearing part with which the tilt plate 6 is provided; 20 indicates a back cover; 21 indicates a liquid crystal television unit; 22 is a turning body [comprising] the front panel 4, the screen 5, the first rotary shaft 8, the second rotary shaft 9, the back cover 20, and the liquid crystal television unit 21; and 23 indicates a television unit fastening screw, which fastens the television unit 21 on the back cover 20.

[0024] In figures 1 to 4, the first rotary shaft 8

rotates centered in the first rotary bearing 10; and when the bottom of the turning body 22 is held by a hand and turned to the front or to the back, around the first rotary shaft, on the second rotary shaft 9, which is arranged at a fixed distance from the first rotary shaft 9 [sic], a plurality of pressure washers 14, the number of which is established as necessary for the pressure force and so the flexures thereof do not exceed the allowable stress, generate a braking force in the turning direction, at the faces at the periphery of a groove in the tilt plate 6, by way of the first washer 12 and the second washer 13, and immobilize the turning body 22 at that position.

[0025] In the same figures, with the turning body 22, and the frame 2 and the tilt plate 6, which are fastened in the seat 1, a gap (S1 in FIG. 3) is provided in the axial direction for the first rotary shaft 8 and the first rotary bearing 10, and for the second rotary shaft 9 and the braking boss 11, which allows movement in the axial direction, allowing for absorption of elastic deformation in the axial direction resulting from the turning force that turns the turning body 22, such that this is not transmitted to the frame 2, and vice versa such that there is no transmission to the turning body 22 when the frame 2 is mounted in the seat 1, or if the frame 2 itself warps.

[0026] Furthermore, in the same figures, the liquid crystal television unit 21 is fastened in the back cover 20, which is made from metal, by the television unit fastening screws 23, and fastened such that a gap (S2 in FIG. 2) is maintained between the liquid crystal surface and the back face of the front panel 4; the screen 5 can be turned in the forward direction by pulling up the bottom end of the back cover 20 with a hand, and the screen 5 can be retracted rearward by pushing the bottom end of the front panel 4, such that the screen 5 can be freely turned to an easily viewed position. When pushing at this time, the gap is maintained between the front panel 4 and the front face of the liquid crystal television unit 21, and therefore force is [not] transmitted to the liquid crystal surface 21a of the liquid crystal television unit 21, and also when the back cover 20 is pulled up, because this is made from metal, force is not transmitted to the liquid crystal television unit 21.

[0027] Furthermore, the second shaft 9, which is engaged in the turning body 22, engages in the braking boss 11, and with the braking boss 11, the gravitational force of the turning body 22 is caused to approach zero, by way of the force of a U-shaped balance spring 18, which is fixedly engaged on the pressing boss 15.

[0028] Immobilization of the turning body 22, while resisting vibration due to the outside forces from the traveling body, with the turning operation of the device configured as described above, in which the gravitational force of the turning body 22 approaches zero due to the force of the U-shaped balance spring 18, which is to say the operation of the function that immobilizes the screen 5, will be described with reference to FIG. 5 to FIG. 7.

[0029] FIG. 5 shows a schematic view in which the situation in which the turning body 22 is housed in the seat is seen from the side; FIG. 6 shows a schematic view in which the situation in which the turning body 22 has been turned away from the seat through approximately one half of the forward stroke is seen from the side; and FIG. 7 shows a schematic view in which the situation in which the turning body has been turned through the full stroke is seen from the side. As shown in FIG. 5 to FIG. 7, the turning body 22 can be turned to any position, and in all of the situations, the [components] that are the same as in the previous figures are given the same reference numerals; in addition, W indicates the movement of the turning body 22; the x mark indicates the center of gravity of the turning body 22; X_G , X'_G , and X''_G indicate the plumb-line distance, in the horizontal direction, from the center of the first shaft to the center of gravity of the turning body 22; P_1 , P_2 , and P_3 indicate the spring force of

force application point between the balance spring and the second rotary shaft 9; and l_1 , l_2 , and l_3 indicate the spring force contact length, to the center of the first rotary shaft 8, in the moment.

[0030] In FIG. 5, the moment resulting from the gravitational force W of the turning body 22, having the first rotary shaft 8 as its axis, is WX_G , in which the counterclockwise direction is defined as the positive direction and the clockwise direction is defined as the negative direction, and by applying approximately the moment of the U-shaped balance spring 17, which is $-P_1l_1$, so as to balance this moment, the force of turning around the first rotary shaft 8, due to the motive force of the turning body 22, approaches zero, and for the remaining moment which is not zero, which is $\Delta M = WX_G - P_1l_1$, the first braking washer 12 and the second braking washer 13 press against the tilt plate 6 due to the force of the pressure washers 14, such that the sliding friction of each causes a braking force [to work], so as to immobilize the turning body 22 against external vibration from the traveling body, in the position shown in the figure, as a result of which the screen 5 is immobilized. Next, contact part 17a of the U-shaped balance spring 17 is approximately U-shaped because, with a torsion spring, the shorter the contact length is, the greater the force thereof will be, and thus this was configured so that the reactive force does not vary greatly with the position of contact, by doubling the contact part.

[0031] In FIGS. 6 and 7, the turning body 22 has been further turned around the first shaft 8, and therefore in the same manner as in the previous figure, approximately P_2 and P_3 are applied so as to balance the moment resulting from the motive force W of the turning body 22 - WX'_G and $-WX''_G$ with the moments P_2l_2 and P_3l_3 resulting from the reactive force of the balance spring 17, and in the same manner as described above, a braking force is applied by the force of the pressure washers 14, for the remaining moments ΔM_2 and ΔM_3 , as a result of which the screen 5 is immobilized from the external vibration of the traveling body.

[0032] In accordance with the foregoing example, an approximate balance in moments is sought, by way of the moment resulting from the motive force W of the turning body 22 and the resistance of the U-shaped balance spring 17, whereby the turning forces that are actually produced by the turning body are such that the moments, which is to say the remaining moments ΔM_1 , ΔM_2 , ΔM_3 are much smaller than the moment resulting from the movement of the turning body, whereby the screen 5 can be immobilized, resisting large external vibrations; and because the braking [force] is applied against this remaining moment, a small force suffices for turning the turning body 22 with the hand.

[0033] Next, a first application embodiment of the positioning embodiment of the present invention will be described hereafter with reference to FIGS. 8, 9 and 10.

[0034] FIG. 8 shows a schematic view of the situation in which the turning body 22 is housed in a seat, as seen from the side, which corresponds to FIG. 5 in the previous example. FIG. 9 shows a schematic view of the situation in which the turning body 22 has been turned away from the seat through approximately one half of the full stroke, which corresponds to FIG. 6 in the previous example. FIG. 10 shows a schematic view of the situation in which the turning body 22 has been turned away from the seat through approximately the full stroke, which corresponds to FIG. 7 in the previous example.

[0035] In FIGS. 8 to 10, components that are the same as in the previous figures are given the same reference numerals, in addition to which, 24 is a dogleg-shaped balance spring, P_4 , P_5 , and P_6 indicate the resistance of the dogleg-shaped balance spring 24 in each situation, and l_4 , l_5 and l_6

each indicate the contact length in the moment, resulting from the resistance of the dogleg-shaped balance spring 24, with the first shaft 8 as the turning center.

[0036] In FIGS. 8, 9 and 10, the moments WX_G , WX'_G and WX''_G produced by the motive force W of the turning body 22 around the first shaft 8, are balanced by the moments P_{4l_4} , P_{5l_5} , and P_{6l_6} when the balance spring 24 provides the resistance, and it is understood that the moment of turning force is much less than the turning moment due to the gravitational force of the turning body 22 alone.

[0037] In this example, when the second shaft reaches the bent portion 24b of the contact part 24a of the dogleg-shaped balance spring 24, a click sensation is produced in the turning force of the turning body 22 at around this point, which has the advantage of making the feeling of having performed the operation clear.

[0038] Next, a second application embodiment of one embodiment of the present invention will be described hereafter with reference to FIGS. 11, 12 and 13.

[0039] FIG. 11 shows a schematic view of a situation in which the turning body 22 is housed in a seat, as seen from the side, which corresponds to FIGS. 5 and 8 in the previous examples. FIG. 12 shows a schematic view of the situation in which the turning body 22 has been turned away from the seat through approximately one half of the full stroke, as seen from the side, which corresponds to FIGS. 6 and 9 in the previous examples. FIG. 13 shows a schematic view of the situation in which the turning body 22 has been turned away from the seat through approximately the full stroke, as seen from the side, which corresponds to FIGS. 7 and 10 in the previous examples.

[0040] In FIGS. 11 to 13, components that are the same as in the previous figures are given the same reference numerals, in addition to which, 25 is a coil spring, P_7 , P_8 , and P_9 indicate the resistance of the coil spring 25 in each situation, and l_7 , l_8 , and l_9 each indicate the contact length in the moment resulting from the resistance of the coil spring 25, with the first shaft 8 as the turning center.

[0041] In FIGS. 11, 12 and 13, the moments WX_G , WX'_G and WX''_G produced by the motive force W of the turning body 22 around the first shaft 8, are balanced by the moments P_{7l_7} , P_{8l_8} , P_{9l_9} , when the coil spring 25 provides the resistance, and it is understood that the moment of turning force is much less than the turning moment due to the gravitational force of the turning body 22 alone.

[0042] In this example, an advantage of the coil spring 25 is that there is generally no variation in the spring force, and therefore it is possible to better balance the gravitational force of the turning body 22.

[0043]

[Effects of the Invention] With the present invention, the elastic deformation of metal spring washers is used in applying a braking force to the turning body so as to immobilize the screen, and the amount of deformation, which is to say the flexibility, is regulated within the allowable stress, and the number of metal springs is increased in order to obtain the necessary braking force, which allows the function to be maintained with a constant braking force over long period of usage; and because the braking force is received on both faces of the tilt plate, which is trapped from both sides, the braking area is twice that in the case of one side, such that the turning body having twice the gravitational force can be immobilized.

[0044] As a result, there is an effect in which the screen can be kept still in a turning position at all times, [against] external vibration from the traveling body, over long periods of time.

[0045] Next, because there is a gap in the axial direction between the rotary shaft of the turning body and the frame that is fastened in the seat, with regard to warping of the frame [during] mounting and deformation due to forces when turning

that corresponds to this gap in each case, the stress due to warping is not transmitted in either case, such that undue forces are not applied to either the turning body or the frame, and thus the weight of both the frame and the turning body can be reduced, which allows for reductions in the costs of the component parts.

[0046] Next, the liquid crystal television unit is housed and fastened in a metal member, and a gap is provided between this and a front panel, in front of this, such that the force that turns the screen is absorbed by the metal member, rather than being transmitted to the liquid crystal surface, which has the effect of eliminating problems due to separation of the solder and the like at the liquid crystal surface, due to turning operations over a long period of time, and protecting the liquid crystal surface from [unusual] operations such as striking the front panel.

[0047] Next, by pushing the weight of the turning body up with a spring, the bearing load on the parts that support the video [sic] body can be greatly reduced, which has the effect of allowing the sizes and weights of the component parts for the shafts, bearings and supports to be reduced, whereby the costs can be reduced and the working lives of the shafts and bearings can be greatly reduced [sic].

[0048] Furthermore, because the weight of the turning body is pushed up by a spring, the force that turns the turning body as a result of the weight is reduced, such that braking of the screen against external vibrations from the traveling body is possible with great force, which has the effect of allowing the screen to be immobilized against greater external vibrations.

[Brief Description of the Drawings]

[FIG. 1] This is a perspective view showing the external appearance of a screen supporting device [according] to one embodiment of the present invention.

[FIG. 2] This is a schematic view of a section along the line I-I in FIG. 1.

[FIG. 3] This is a schematic view of a partial section of FIG. 1, seen from the direction of the arrow (A) in the figure.

[FIG. 4] This is a schematic view of a section along the line II-II in FIG. 1, seen from the direction of the arrow (B) in the figure.

[FIG. 5] This is a schematic view of the operation of one embodiment of the present invention, seen from the side.

[FIG. 6] This is likewise a schematic view seen from the side.

[FIG. 7] This is likewise a schematic view seen from the side.

[FIG. 8] This is a schematic view of the operation of a first application embodiment of one embodiment of the present invention, seen from the side.

[FIG. 9] This is likewise a schematic view seen from the side.

[FIG. 10] This is likewise a schematic view seen from the side.

[FIG. 11] This is a schematic view of the operation of a second application embodiment of one embodiment of the present invention, seen from the side.

[FIG. 12] This is likewise a schematic view seen from the side.

[FIG. 13] This is likewise a schematic view seen from the side.

[FIG. 14] This is a sketch of the external appearance of a conventional example.

[Fig. 15] This is a sketch of the external appearance of a conventional example.

[Explanation of the Symbols]

1... seat,

Explore Litigation Insights

Docket Alarm provides insights to develop a more informed litigation strategy and the peace of mind of knowing you're on top of things.

Real-Time Litigation Alerts



Keep your litigation team up-to-date with **real-time alerts** and advanced team management tools built for the enterprise, all while greatly reducing PACER spend.

Our comprehensive service means we can handle Federal, State, and Administrative courts across the country.

Advanced Docket Research



With over 230 million records, Docket Alarm's cloud-native docket research platform finds what other services can't. Coverage includes Federal, State, plus PTAB, TTAB, ITC and NLRB decisions, all in one place.

Identify arguments that have been successful in the past with full text, pinpoint searching. Link to case law cited within any court document via Fastcase.

Analytics At Your Fingertips



Learn what happened the last time a particular judge, opposing counsel or company faced cases similar to yours.

Advanced out-of-the-box PTAB and TTAB analytics are always at your fingertips.

API

Docket Alarm offers a powerful API (application programming interface) to developers that want to integrate case filings into their apps.

LAW FIRMS

Build custom dashboards for your attorneys and clients with live data direct from the court.

Automate many repetitive legal tasks like conflict checks, document management, and marketing.

FINANCIAL INSTITUTIONS

Litigation and bankruptcy checks for companies and debtors.

E-DISCOVERY AND LEGAL VENDORS

Sync your system to PACER to automate legal marketing.