

(51) Int. Cl. <sup>5</sup>	Identification Code	Internal File No.	FI	Tech. Indic.
H04N 5/64	501 D	7205-5C		
E04F 19/08	102 Z	7151-2E		
G03B 21/10	D	7316-2K		
G09F 19/22	D	6447-5G		
H04N 5/74	F	7205-5C		

Examination Request: not yet made    Number of Claims: 2    Number of Pages 5

(21) Application No.:	3-90761	(71) Applicant:	000005016 Pioneer Corporation 1-4-1 Meguro, Meguro-Ku, Tokyo-to
(22) Application Date:	April 22, 1991	(72) Inventor:	SASAO, Minoru Pioneer Corporation Omori Factory, 4-15-5 Omorinishi, Ota-Ku, Tokyo-to
		(74) Agent:	Patent Attorney, ISHIKAWA, Yasuo (and one other person)

(54) Title of the Invention: Display Device

(57) [Abstract]

[Object] To provide a display device with which the perceived presence of the cabinet can be entirely eliminated, such that only the necessary image is produced.

[Configuration] This comprises: a main display unit disposed at an opening that is formed in a wall of a room in a building, with the front face of an image formation part facing the interior of the room; and a frame member, which is engaged on the main display unit, disposed at the periphery of the image formation part, so as to cover a gap between the main display unit and the edge of the opening.

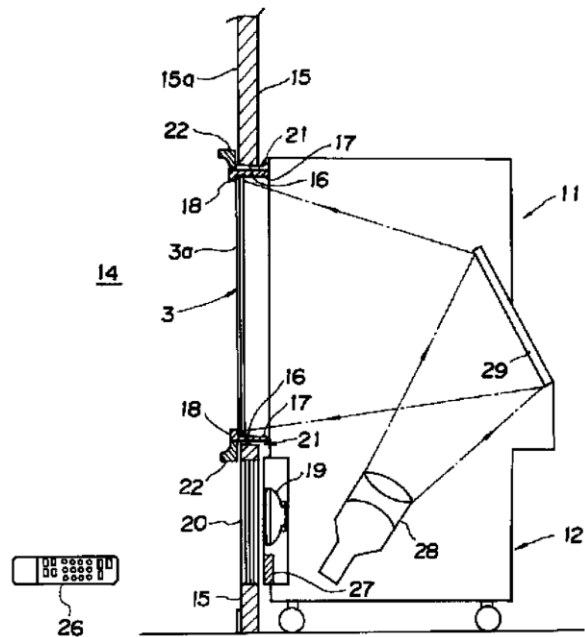

**[Claims]**

**[Claim 1]** A display device characterized by comprising: a main display unit disposed at an opening that is formed in a wall of a room in a building, with the front face of an image formation part facing the interior of the room; and a frame member, which is engaged on the main display unit, disposed at the periphery of the image formation part, so as to cover a gap between the main display unit and the edge of the opening.

**[Claim 2]** The display device according to claim 1, characterized in that an engagement part is formed on the main display unit, and desired frame members can be exchanged on this engagement part.

**[Detailed Description of the Invention]****[0001]**

**[Field of Industrial Application]** The present invention relates to a display device such as a rear projection television, and in particular relates to a display device that is structured so as to be housed at the interior of a wall.

**[0002]**

**[Prior Art]** Rear projection televisions as mentioned above have built-in CRTs for R (red [sic]), G (green) and B (blue), and the colored light that is emitted from each of these CRTs irradiates the back face of a screen mounted in a cabinet so as to form a color image on the front face of the screen. Such rear projection televisions, or ordinary market available televisions that use a normal CRT, are normally used by placing them in the living room of an ordinary residence or in a viewing room in a commercial building.

**[0003]**

**[Problems to Be Solved by the Invention]** However, the aforementioned rear projection televisions and ordinary televisions alone take up their own space when set up in rooms, and the perceived presence of the main television unit is strongly felt. In particular, as the cabinets of the aforementioned rear projection televisions were normally large, they occupied a large amount of space when set up in a room, and thus the perceived presence thereof was even greater. Furthermore, there were problems in so much as large rear projection television devices were in the way, and made the room smaller, and in particular in cases such as that of an ordinary residence with small rooms, it was not possible to view them from more than a predetermined distance from the screen.

**[0004]** The presence of such cabinets reduced the concentration of the viewer on the content of the images that were displayed on the screen, such that the presence of the cabinet itself had a negative impact, constituting what might be termed a noise factor. The present invention was made in order to solve such problems, and an object thereof is to produce a display device that can entirely eliminate the perceived presence of the cabinet.

**[0005]** Furthermore, an object is to produce a display device that allows the frame member to be freely selected in keeping with the content of the image.

**[0006]**

**[Means for Solving the Problems]** The display device according to the present invention comprises: a main display unit disposed at an opening that is formed in a wall of a room in a building, with the front face of an image formation part facing the interior of the room; and a frame member, which is engaged on the main display unit, disposed at the periphery of the image formation part, so as to cover a gap between the main display unit and the edge

**[0007]** Furthermore, it is preferable that an engagement part be formed on the main display unit, and that desired frame members can be exchanged on this engagement part.

**[0008]**

**[Operation]** In the present invention, the front face of the image formation part of the main display unit is disposed in an opening formed in a wall of the room, and the cabinet of the main display unit is installed outside of the room, such that only the front face of the image formation part can be seen from within the room.

**[0009]**

**[Embodiments]** Hereafter, an embodiment of the present invention will be described based on the drawings. FIG. 1 shows an ordinary market available rear projection television 1, which is set up in a room; the rear projection television 1, serving as the main display unit, has a cabinet 2; and electronic components and optical components for forming a color image on the front face of a screen 3, serving as the image formation part, are housed within the cabinet 2.

**[0010]** In the present invention, this rear projection television 1 can be used as is, but in a preferred embodiment, one wherein this rear projection television 1 is partially modified, as shown in FIG. 2, is used. That is to say, as shown in FIGS. 2 and 3, a rear projection television 11 serving as a main display unit according to the present embodiment is disposed with a front face 3a of a rectangular screen 3, which serves as the image formation part, facing the interior of a room 14, at an opening 16 that is formed in a wall 15 of the room 14, in an ordinary residential or commercial building. The front face 3a of the screen 3, which is provided at the front (to the left in FIG. 2) of the cabinet 12 of such a rear projection television 11, is positioned forward of the front 12a of the cabinet 12 by a distance  $D_1$  (for example,  $D_1 = 25$  mm); this distance  $D_1$  is made greater than the distance  $D_2$  (for example,  $D_2 = 10$  mm) between the front 6 of the cabinet and the front face 3a of the screen of the market available rear projection television 1 shown in FIG. 1. The cabinet 12 itself is disposed behind the wall 15 and cannot be seen from within the room 14; furthermore, as described above, the screen 3 protrudes forward from the cabinet 12 so that the front face 3a of the screen and the wall surface 15a in the room 14 are substantially flush. Reference numeral 17 [indicates] a support member (screen frame), which protrudes forward from the cabinet 12 and is rectangular as seen from the front, the back end of which is attached to the front 12a of the cabinet 12, and supports the screen 3 with an engagement part 18 at the front end thereof; this is normally made from a plastic or aluminum material. This support member 17 is preferably such that the width of the member as seen from the front is

as thin and narrow as possible (for example, a width of 3 mm). Thus, with the rear projection television 11 shown in FIG. 2, the screen 3 is positioned further forward than that of the rear projection television 1 shown in FIG. 1 by a distance ( $D_1 - D_2$ ) (for example, 15 mm) and therefore the electronic components and optical components serving to form a clear color image on the front face 3a of this screen 3 are disposed so as to be shifted forward by the necessary distance (for example 15 mm).

**[0011]** Furthermore, in the rear projection television 1 shown in FIG. 1, Saran net 7 for covering a speaker and support members 8a, 8b that support this Saran net 7 are provided below the front 6 of the cabinet 2, but in the rear projection television 11 shown in FIG. 2, such Saran net 7 and support members 8a, 8b are eliminated [sic]. In their place, as shown in FIG. 3, a speaker Saran net 20 is formed in the wall 15, in front of the speaker 19 that is mounted on the lower front of the cabinet 12, corresponding to the position of this speaker 19, whereby the sound that is generated by the speaker 19 passes through the speaker Saran net 20, and reaches the interior of the room 14.

**[0012]** Further, in the present invention, a frame a member 22 is disposed at the peripheral edge of the screen 3, which covers a gap 21 between the rear projection television 11 and the edge of the opening 16 in the wall 15, this frame member 22 engaging on the rear projection television 11. As a more preferred mode for the present embodiment, an engagement part 23 is formed at the outer peripheral face of the support member 17, in the vicinity of the forward end thereof, which allows the frame member 22 to be replaced by way of engagement and disengagement, when the rear projection television 11 has been positioned by way of inserting the support member 17, which supports the screen 3, into the opening 16 in the wall 15. This engagement part 23 may have a flat surface but, preferably, a groove-like height differential is formed so that the frame member 22 will not accidentally fall off of this engagement part 23 but rather the frame member 22 can be held with a suitable force, and so that it can be mounted or dismounted with a single operation. Furthermore, this frame member may be fixed in place in an easily mountable and dismountable manner, by way of Velcro or screw members in positions that cannot be seen from within the room.

**[0013]** It will be noted that, as shown in FIG. 3 and 4, the cabinet 12 of the rear projection television 11 is set up behind the wall 15, and therefore requires no decoration whatsoever, but ordinary decoration is provided on the support member 17 and the frame member 22, which are exposed to the interior of the room. In particular, it is possible to prepare multiple types of frame members 22 on which differing decoration is provided, such as providing a frame 24 that gives a heavy impression when still images such as pictures 100 or the like are [displayed] (FIG. 5) and providing a frame 25 that has a plain feel when other images (for example moving images such as a television broadcast) are [displayed] (FIG. 6), and to select the frame member 22 with the most suitable decoration for the content of the image that is formed on the screen 3, and engage this on the engagement part 23 of the support member 17, allowing only the image on the screen 3 and the frame member 22 to be seen, while the cabinet 12 itself cannot be seen at all from the interior of the room 14. In particular, when a BGV videotape is used so as to form a still image such as scenery on the screen 3, it is possible to achieve an

frame has been hung on the wall surface 15a, and to produce a comfortably harmonious feeling, without the design of the frame producing a discordant feeling with respect to the content of the image. Meanwhile, when a television broadcast is received, it is preferable to use a frame member 22 that is merely a frame, with which the perceived presence of the frame can be abstracted to as great an extent as possible.

**[0014]** Note that, in order to operate this rear projection television 11, a portable controller 26 having an infrared emitter unit is placed within the room 14, and infrared signals are emitted from this controller 26. The emitted infrared signals pass through the speaker Saran net 20, whereafter they are received by an infrared receiver unit 27, which is installed facing forward in the vicinity of the speaker 19, and command signals are output to the electronic components and optical components within the cabinet 12, from this infrared receiver unit 27. Consequently, colored light emitted from a CRT lens-block 28 is reflected by a reflector 29, and then irradiates the back face of the screen 3, forming a color image on the front face 3a of the screen 3.

**[0015]** Furthermore, with the present embodiment, the cabinet 12 is set up behind the wall 15, and therefore it is not necessary to provide decoration on this cabinet 12 itself, allowing for cost reductions in terms of the materials and the decoration for the cabinet 12. Further, safety can be improved by making this cabinet 12 out of a material having good fire resistance. Furthermore, when the rear projection television 11 is off and no image is formed on the screen 3, the frame member 22 (or the frame 24 or 25) on which decoration has been provided constitutes an effective part of the interior design of the room 14.

**[0016]** Note that, in the embodiment described above, a case was shown in which the rear projection television 11 served as the main display unit, but an ordinary television having a CRT may serve as the image formation part. Furthermore, the type of wall as well as the material therefor, the color thereof and the like may be freely chosen, and there are no restrictions on the location of the wall, such that opening can be provided at a desired location in the wall and the rear projection television 11 can be set up there.

**[0017]**

**[Effects of the Invention]** Because the present invention according to claim 1 is configured as described above, only the image formation part will be seen from the interior of the room, without the main display unit being seen at all, which eliminates the perceived presence of the main display unit, allowing only the necessary image to be produced, and because the gap between the main display unit and the opening in the wall is covered by the frame member, the gap is not exposed to the interior of the room.

**[0018]** Furthermore, because the present invention according to claim 2 is configured as described above, it is possible to achieve harmony between the image and the frame member by freely selecting the frame member according to the content of the image on the image formation part.

**[Brief Description of the Drawings]**

**[FIG. 1]** This is a side view of a market available rear projection television.

**[FIG. 2]** This is a side view of a rear projection television showing one embodiment of the present invention.

**[FIG. 3]** This is a side structural view showing the situation in which the rear projection television shown in FIG. 2 has been set up at an opening in a wall.

**[FIG. 4]** This is an explanatory diagram serving to explain the situation in FIG. 3.

**[FIG. 5]** This is a front view of the situation in which a frame for the rear projection television shown in FIG. 2 has been mounted.

**[FIG. 6]** This is a front view of the situation in which another frame for the rear projection television shown in FIG. 2 has been mounted.

**[Explanation of the Symbols]**

- 1, 11 ...rear projection television (main display unit)
- 3 ...screen (image formation part)
- 3a ...front face
- 14 ...room
- 15 ...wall
- 16 ...opening
- 21 ...gap
- 22 ...frame member
- 23 ...engagement part
- 24, 25 ...frame (frame member)

**[FIG. 1]**

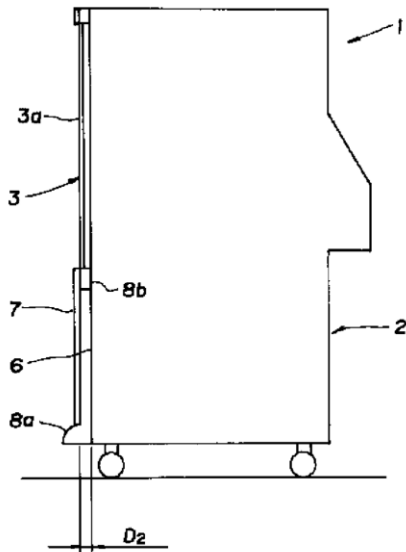

**[FIG. 2]**

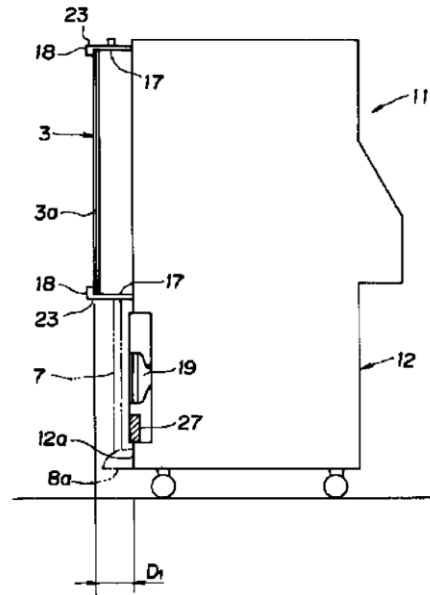

**[FIG. 4]**

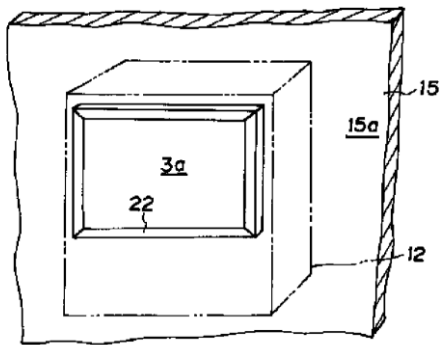

(5)

[FIG. 3]

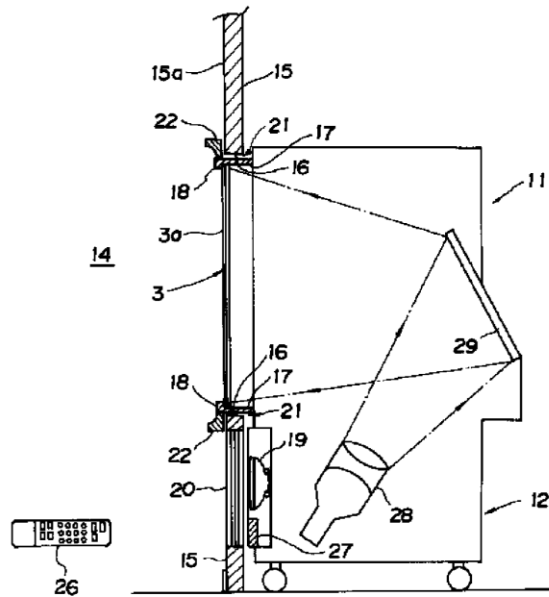

[FIG. 5]

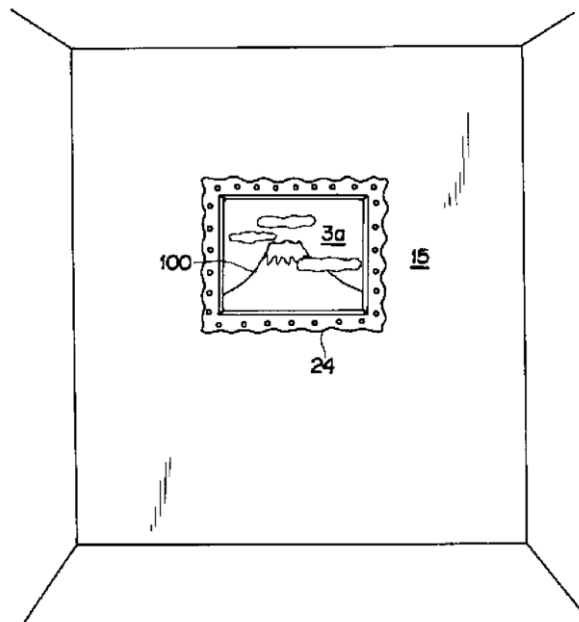

[FIG. 6]

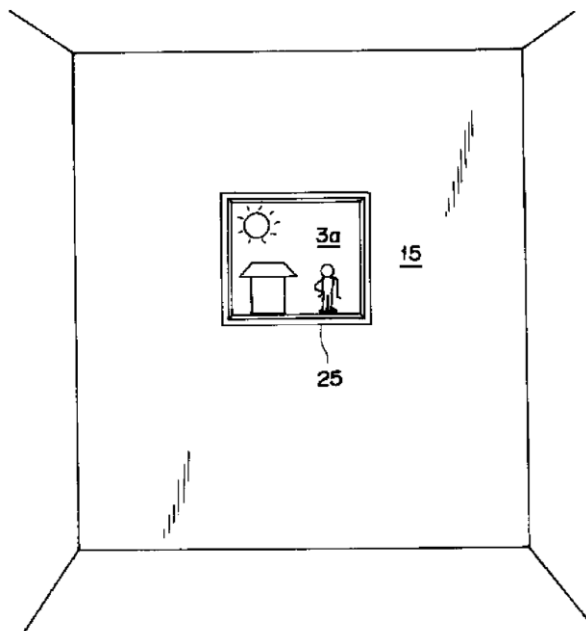

# Explore Litigation Insights

Docket Alarm provides insights to develop a more informed litigation strategy and the peace of mind of knowing you're on top of things.

## Real-Time Litigation Alerts



Keep your litigation team up-to-date with **real-time alerts** and advanced team management tools built for the enterprise, all while greatly reducing PACER spend.

Our comprehensive service means we can handle Federal, State, and Administrative courts across the country.

## Advanced Docket Research



With over 230 million records, Docket Alarm's cloud-native docket research platform finds what other services can't. Coverage includes Federal, State, plus PTAB, TTAB, ITC and NLRB decisions, all in one place.

Identify arguments that have been successful in the past with full text, pinpoint searching. Link to case law cited within any court document via Fastcase.

## Analytics At Your Fingertips



Learn what happened the last time a particular judge, opposing counsel or company faced cases similar to yours.

Advanced out-of-the-box PTAB and TTAB analytics are always at your fingertips.

## API

Docket Alarm offers a powerful API (application programming interface) to developers that want to integrate case filings into their apps.

## LAW FIRMS

Build custom dashboards for your attorneys and clients with live data direct from the court.

Automate many repetitive legal tasks like conflict checks, document management, and marketing.

## FINANCIAL INSTITUTIONS

Litigation and bankruptcy checks for companies and debtors.

## E-DISCOVERY AND LEGAL VENDORS

Sync your system to PACER to automate legal marketing.