



US007268703B1

(12) **United States Patent**
Kabel et al.

(10) **Patent No.:** **US 7,268,703 B1**
(45) **Date of Patent:** **Sep. 11, 2007**

(54) **METHODS, SYSTEMS, AND DEVICES FOR CARTOGRAPHIC ALERTS**

(75) Inventors: **Darrin W. Kabel**, Overland Park, KS (US); **Steven J. Myers**, Edgerton, KS (US)

(73) Assignee: **Garmin Ltd.** (KY)

(*) Notice: Subject to any disclaimer, the term of this patent is extended or adjusted under 35 U.S.C. 154(b) by 71 days.

(21) Appl. No.: **10/667,026**

(22) Filed: **Sep. 18, 2003**

(51) **Int. Cl.**
B60L 3/00 (2006.01)
G06F 7/00 (2006.01)
G06F 17/10 (2006.01)
G08B 23/00 (2006.01)

(52) **U.S. Cl.** **340/984**; 701/21; 701/301

(58) **Field of Classification Search** 340/686.6, 340/995.1, 984, 985, 851, 539.13, 539.2, 340/539.22, 7.56, 825.36, 961, 995.11, 850; 367/909, 87-116; 342/41, 357.13; 701/21, 701/201, 301, 211

See application file for complete search history.

(56) **References Cited**

U.S. PATENT DOCUMENTS

3,886,487 A *	5/1975	Walsh et al.	367/92
4,323,992 A *	4/1982	Tobin, Jr.	367/108
4,340,936 A *	7/1982	Mounce	701/200
4,646,244 A	2/1987	Bateman et al.	364/461
4,873,676 A *	10/1989	Bailey et al.	367/98
4,893,127 A *	1/1990	Clark et al.	342/386
5,220,507 A	6/1993	Kirson	
5,339,085 A	8/1994	Katoh et al.	342/180
5,398,188 A	3/1995	Maruyama	
5,470,233 A	11/1995	Fruchterman et al.	434/112
5,543,789 A	8/1996	Behr et al.	

5,559,707 A	9/1996	DeLorme et al.	
5,592,382 A	1/1997	Colley	701/207
5,635,924 A	6/1997	Tran et al.	
5,684,476 A	11/1997	Anderson	340/988
5,872,526 A	2/1999	Tognazzini	340/961
5,878,368 A	3/1999	DeGraaf	
5,893,081 A	4/1999	Poppen	

(Continued)

FOREIGN PATENT DOCUMENTS

JP 2002-288800 A * 10/2002

OTHER PUBLICATIONS

C-Series Display Reference Manual, Raymarine UK, Mar. 2006.
GPSMAP 3600C/3010C Color Chartplotter, Garmin Ltd., 2004.
GPSMAP 206/2010 Chartplotters Owner's Manual and Reference Guide, Garmin Ltd., 2001.

Primary Examiner—Benjamin C. Lee
Assistant Examiner—Jennifer Mehmood
(74) *Attorney, Agent, or Firm*—David L. Terrell

(57) **ABSTRACT**

Systems, devices, and methods are provided for marine navigation and course calculation for avoiding preselected conditions. An electronic marine navigation device with marine course calculation capabilities includes a processor connected to a memory that includes cartographic data. A potential waypoint can be identified and a marine route calculation algorithm can be performed to calculate a course between a first location and the potential waypoint in view of preselected conditions. Performing the marine route calculation algorithm includes analyzing the cartographic data for the area between the first location and the potential waypoint with a preference for providing a course that avoids preselected conditions. A display is connected to the processor and is capable of displaying the calculated course and cartographic data. The device is also adapted to dynamically analyze an area surrounding the first location for preselected conditions and display the results of the analysis.

50 Claims, 10 Drawing Sheets

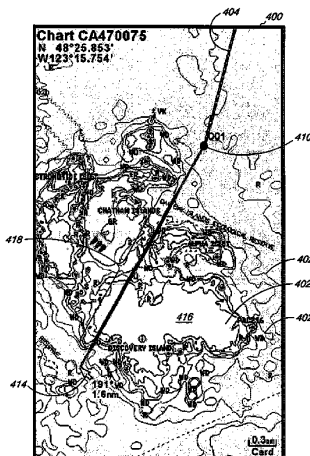

US 7,268,703 B1

Page 2

U.S. PATENT DOCUMENTS

5,999,882 A	12/1999	Simpson et al.	702/3	6,473,003 B2 *	10/2002	Horvath et al.	340/945
6,055,478 A	4/2000	Heron	701/213	6,556,206 B1	4/2003	Benson et al.	345/473
6,061,629 A	5/2000	Yano et al.		6,574,551 B1	6/2003	Maxwell et al.	701/209
6,104,316 A	8/2000	Behr et al.		6,577,947 B1	6/2003	Kronfeld et al.	
6,198,428 B1	3/2001	Sekine	342/176	6,653,947 B2	11/2003	Dwyer et al.	340/970
6,199,015 B1	3/2001	Curtwright et al.	701/213	6,654,689 B1	11/2003	Kelly	
6,279,851 B1	8/2001	Huss et al.	244/3.15	6,665,630 B2	12/2003	Wei et al.	702/155
6,289,277 B1	9/2001	Feyereisen et al.		6,734,808 B1 *	5/2004	Michaelson et al.	340/984
6,314,370 B1	11/2001	Curtright	701/213	6,750,815 B2	6/2004	Michaelson et al. ...	342/357.13
6,356,837 B1	3/2002	Yokota et al.	701/208	6,845,324 B2	1/2005	Smith	
6,362,751 B1	3/2002	Upparapalli		6,862,501 B2	3/2005	He	701/3
6,981,538 B2	4/2002	Robinson et al.		6,885,919 B1 *	4/2005	Wyant et al.	701/21
6,385,538 B1	5/2002	Yokota	701/211	7,035,166 B2	4/2006	Zimmerman et al.	367/88
6,401,038 B2	6/2002	Gia	701/301	2002/0121989 A1	9/2002	Burns	
6,421,603 B1	7/2002	Pratt et al.	701/206	2004/0003958 A1 *	1/2004	Fujimoto et al.	181/124
6,469,664 B1	10/2002	Michaelson et al. ...	342/357.13	2004/0006423 A1 *	1/2004	Fujimoto et al.	701/201

* cited by examiner

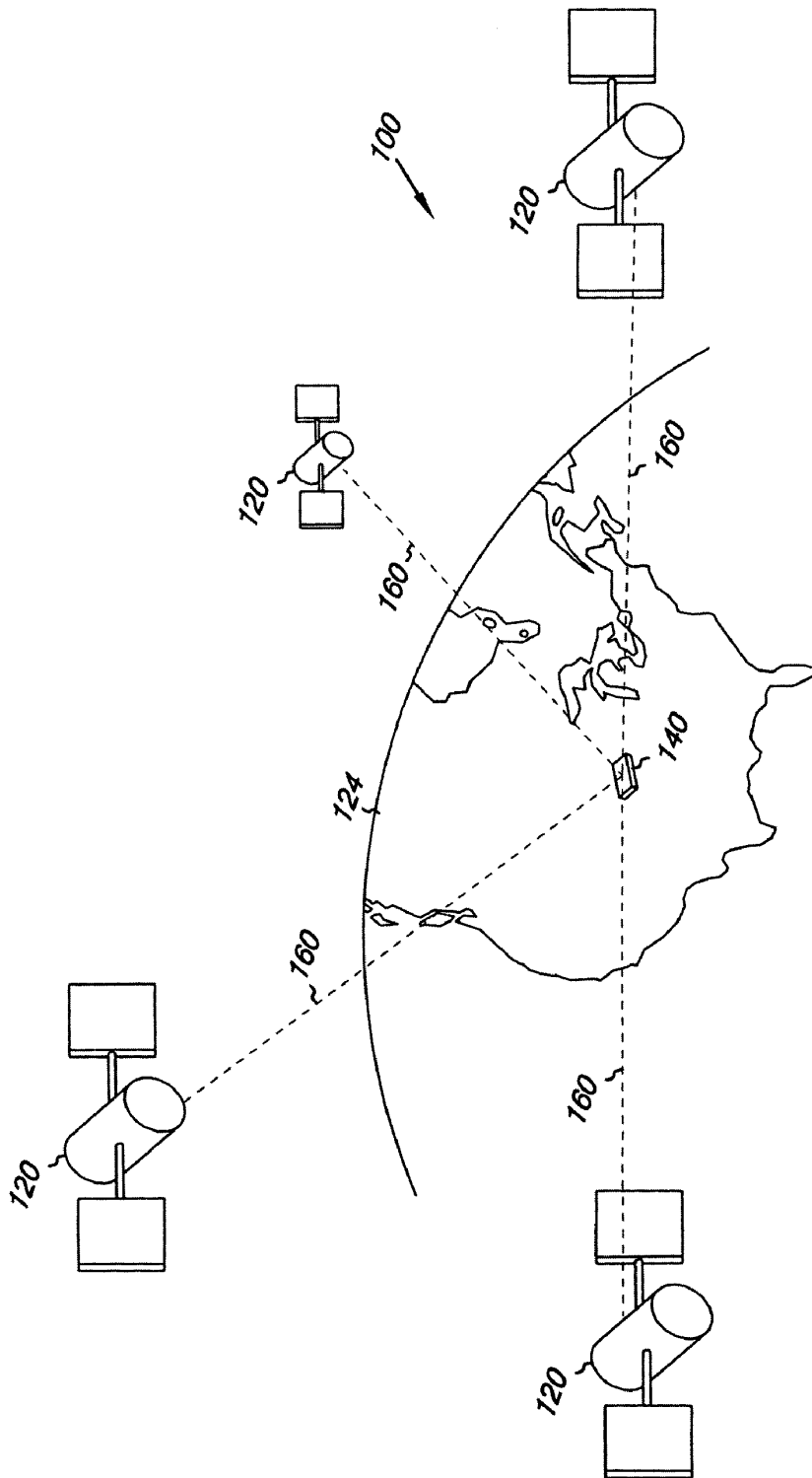

Fig. 1

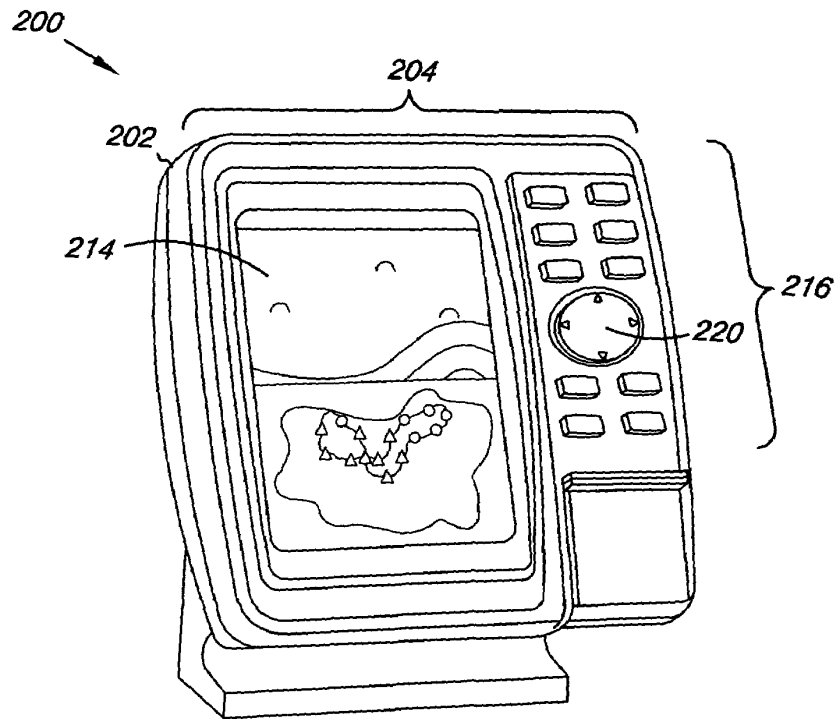

Fig. 2A

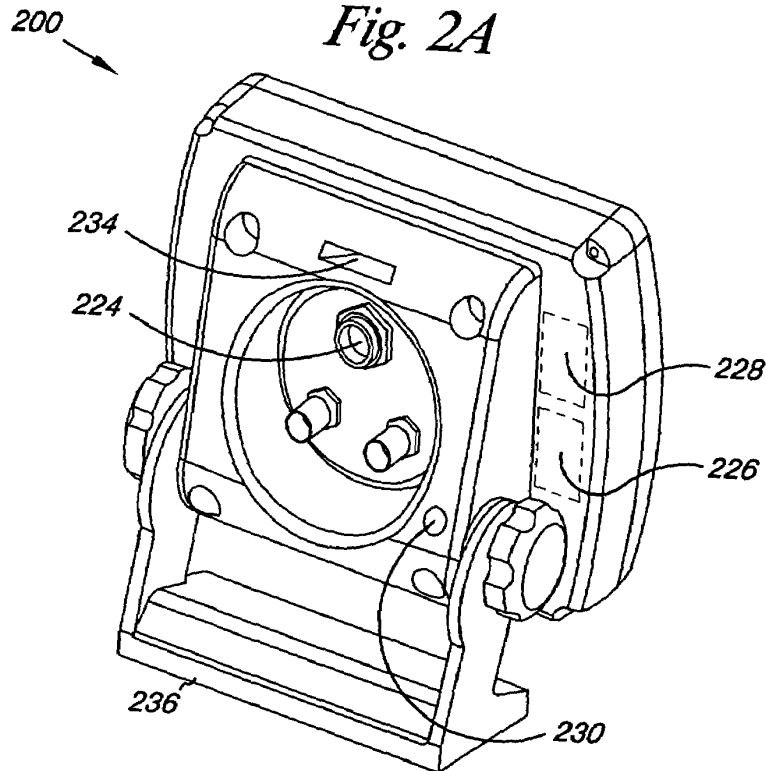

Fig. 2B

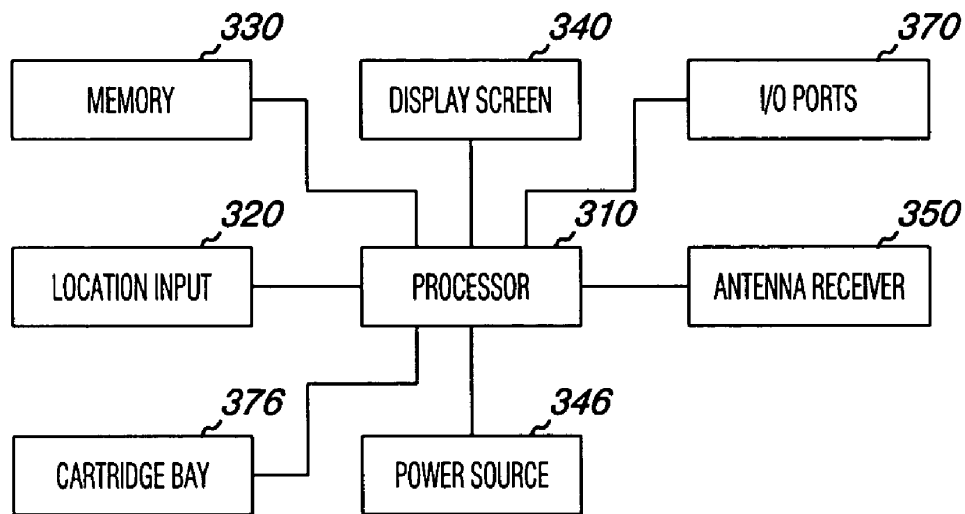

Fig. 3

Explore Litigation Insights

Docket Alarm provides insights to develop a more informed litigation strategy and the peace of mind of knowing you're on top of things.

Real-Time Litigation Alerts



Keep your litigation team up-to-date with **real-time alerts** and advanced team management tools built for the enterprise, all while greatly reducing PACER spend.

Our comprehensive service means we can handle Federal, State, and Administrative courts across the country.

Advanced Docket Research



With over 230 million records, Docket Alarm's cloud-native docket research platform finds what other services can't. Coverage includes Federal, State, plus PTAB, TTAB, ITC and NLRB decisions, all in one place.

Identify arguments that have been successful in the past with full text, pinpoint searching. Link to case law cited within any court document via Fastcase.

Analytics At Your Fingertips



Learn what happened the last time a particular judge, opposing counsel or company faced cases similar to yours.

Advanced out-of-the-box PTAB and TTAB analytics are always at your fingertips.

API

Docket Alarm offers a powerful API (application programming interface) to developers that want to integrate case filings into their apps.

LAW FIRMS

Build custom dashboards for your attorneys and clients with live data direct from the court.

Automate many repetitive legal tasks like conflict checks, document management, and marketing.

FINANCIAL INSTITUTIONS

Litigation and bankruptcy checks for companies and debtors.

E-DISCOVERY AND LEGAL VENDORS

Sync your system to PACER to automate legal marketing.