

[54] SPLIT-POLYSILICON CMOS PROCESS INCORPORATING SELF-ALIGNED SILICIDATION OF CONDUCTIVE REGIONS

[75] Inventors: Tyler A. Lowrey; Dermot M. Durcan; Trung T. Doan; Gordon A. Haller; Mark E. Tuttle, all of Boise, Id.

[73] Assignee: Micron Technology, Inc., Boise, Id.

[21] Appl. No.: 485,029

[22] Filed: Feb. 26, 1990

[51] Int. Cl.⁵ H01L 21/265; H01L 21/336

[52] U.S. Cl. 437/34; 437/44; 437/57; 357/42; 357/44

[58] Field of Search 437/27, 28, 29, 30, 437/34, 56, 57, 200, 192, 40, 41, 44, 233; 357/23.3, 23.4, 40, 41, 42, 44

[56] References Cited

U.S. PATENT DOCUMENTS

4,530,150	7/1985	Shirato	437/44
4,577,391	3/1986	Hsia et al.	437/34
4,599,789	7/1986	Gasner	437/34
4,637,124	1/1987	Okuyama et al.	437/41
4,745,086	5/1988	Parrillo	437/44

FOREIGN PATENT DOCUMENTS

0019669	2/1981	Japan	437/41
0017164	1/1982	Japan	437/34
0055068	3/1984	Japan	437/41
0213051	10/1985	Japan	437/44
0165355	7/1987	Japan	437/233

Primary Examiner—Olik Chaudhuri
Assistant Examiner—M. Wilczewski

Attorney, Agent, or Firm—Angus C. Fox, III; Stanley N. Protigal; Albert Crowder

[57] ABSTRACT

An improved CMOS fabrication process which uses separate masking steps to pattern N-channel and P-channel transistor gates from a single layer of conductively-doped polycrystalline silicon (poly) and incorporates self-aligned silicidation of conductive regions. The object of the improved process is to reduce the cost and improve the reliability, performance and manufacturability of CMOS devices by a process which features a dramatically reduced number of photomasking steps and which further allows self-aligned silicidation of transistor conductive regions. By processing N-channel and P-channel devices separately, the number of photomasking steps required to fabricate complete CMOS circuitry in a single-polysilicon-layer or single-metal layer process can be reduced from eleven to eight. Starting with a substrate of P-type material, N-channel devices are formed first, with unetched poly left in the future P-channel regions until N-channel processing is complete. The improved CMOS process provides the following advantages over conventional process technology: Use of a masked high-energy punch-through implant for N-channel devices is not required; individual optimization of N-channel and P-channel transistors is made possible; a lightly-doped drain (LDD) design for both N-channel and P-channel transistors is readily implemented; source/drain-to-gate offset may be changed independently for N-channel and P-channel devices; and N-channel and P-channel transistors can be independently controlled and optimized for best LDD performance and reliability.

5 Claims, 13 Drawing Sheets

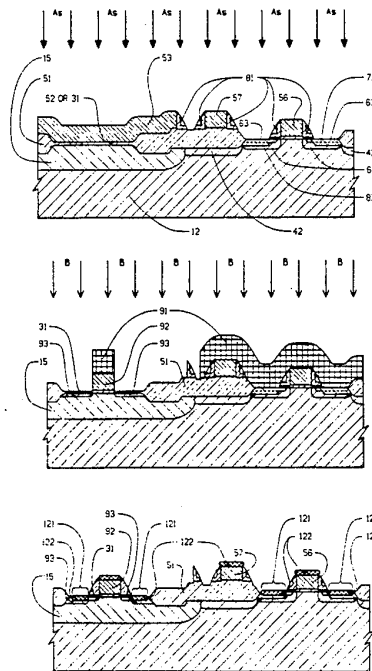

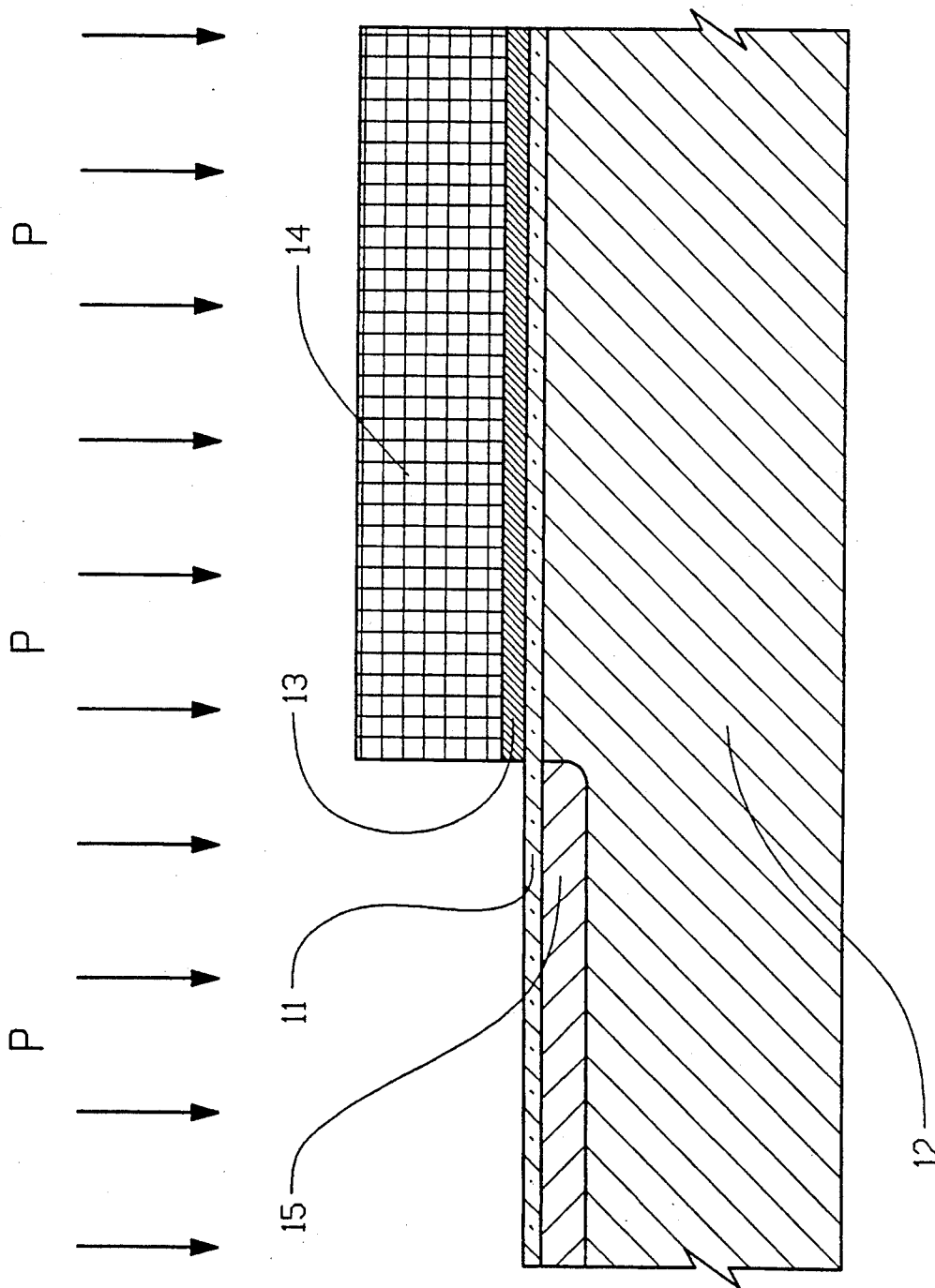

FIG. 1

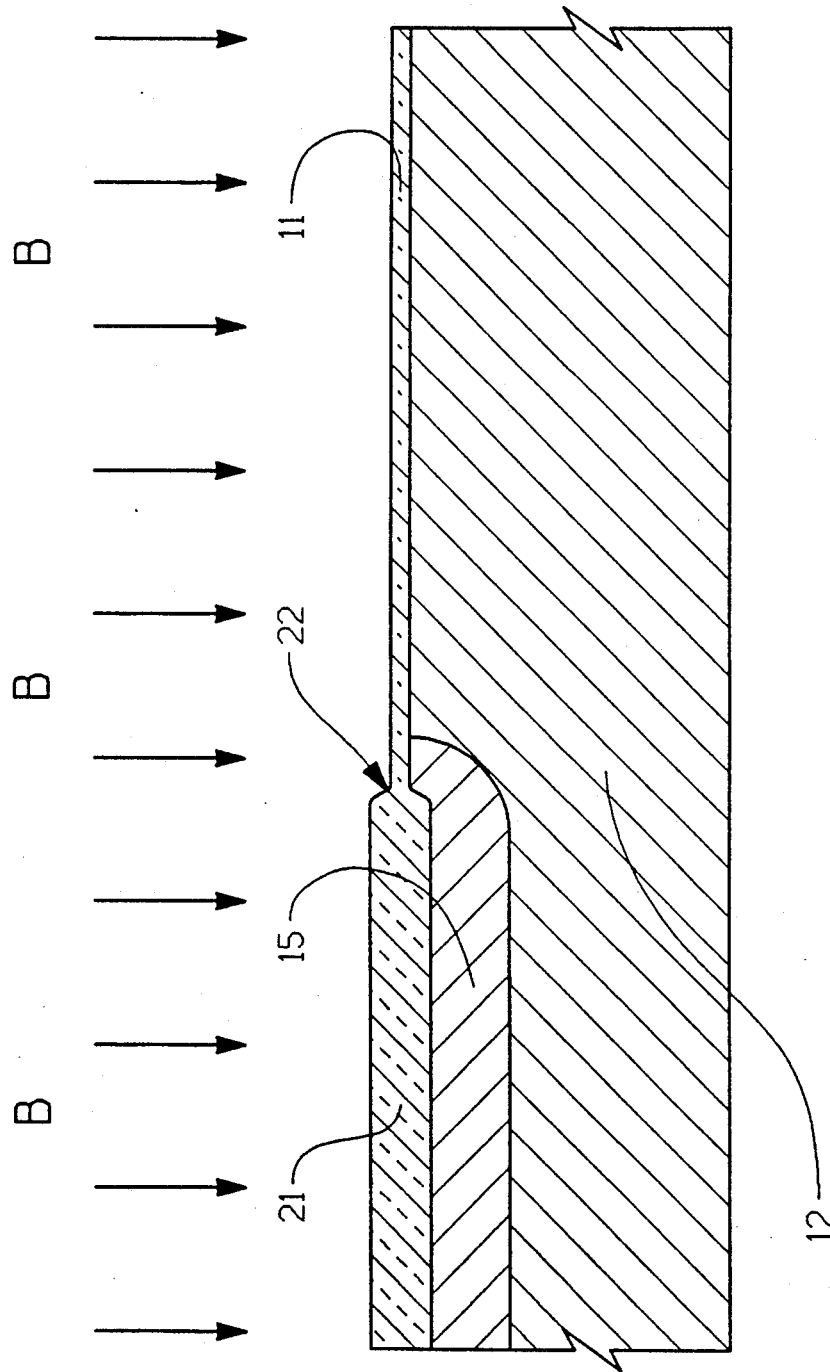

FIG. 2

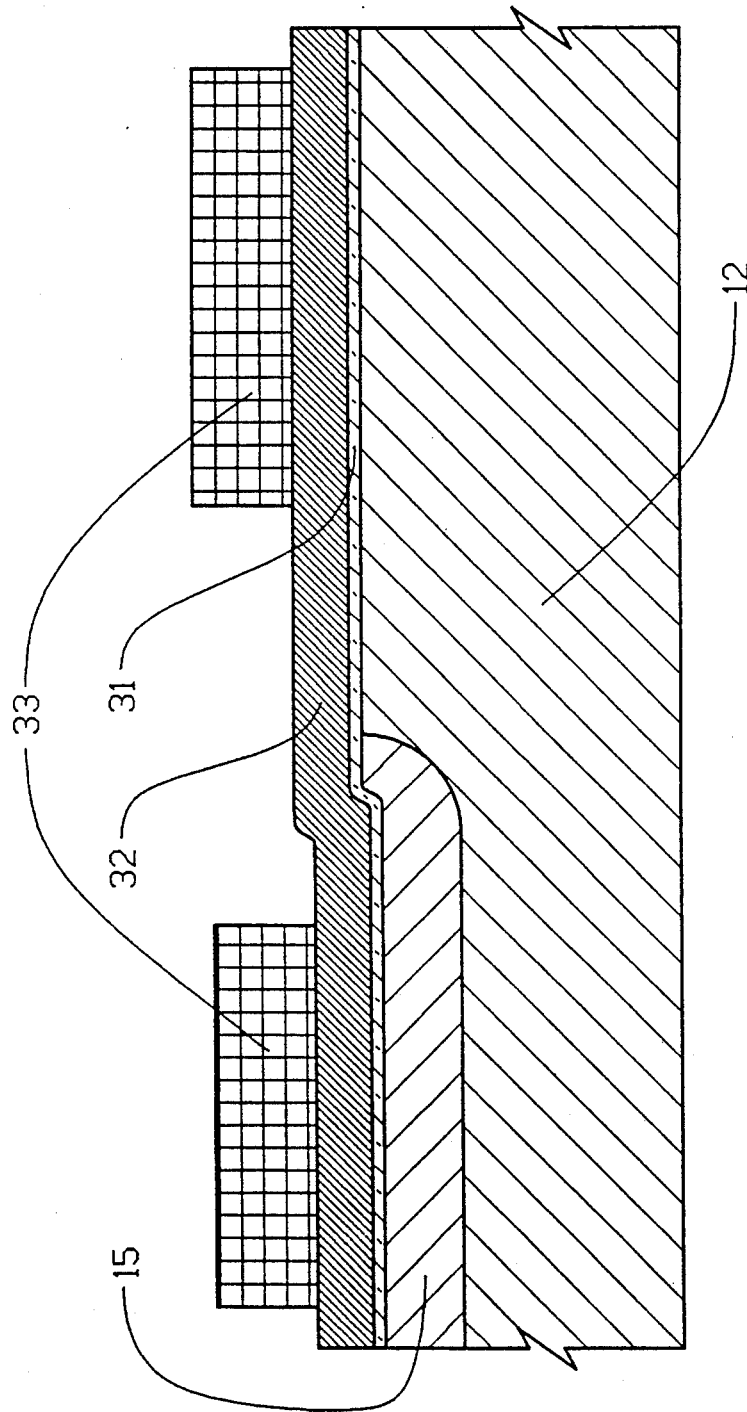

FIG. 3

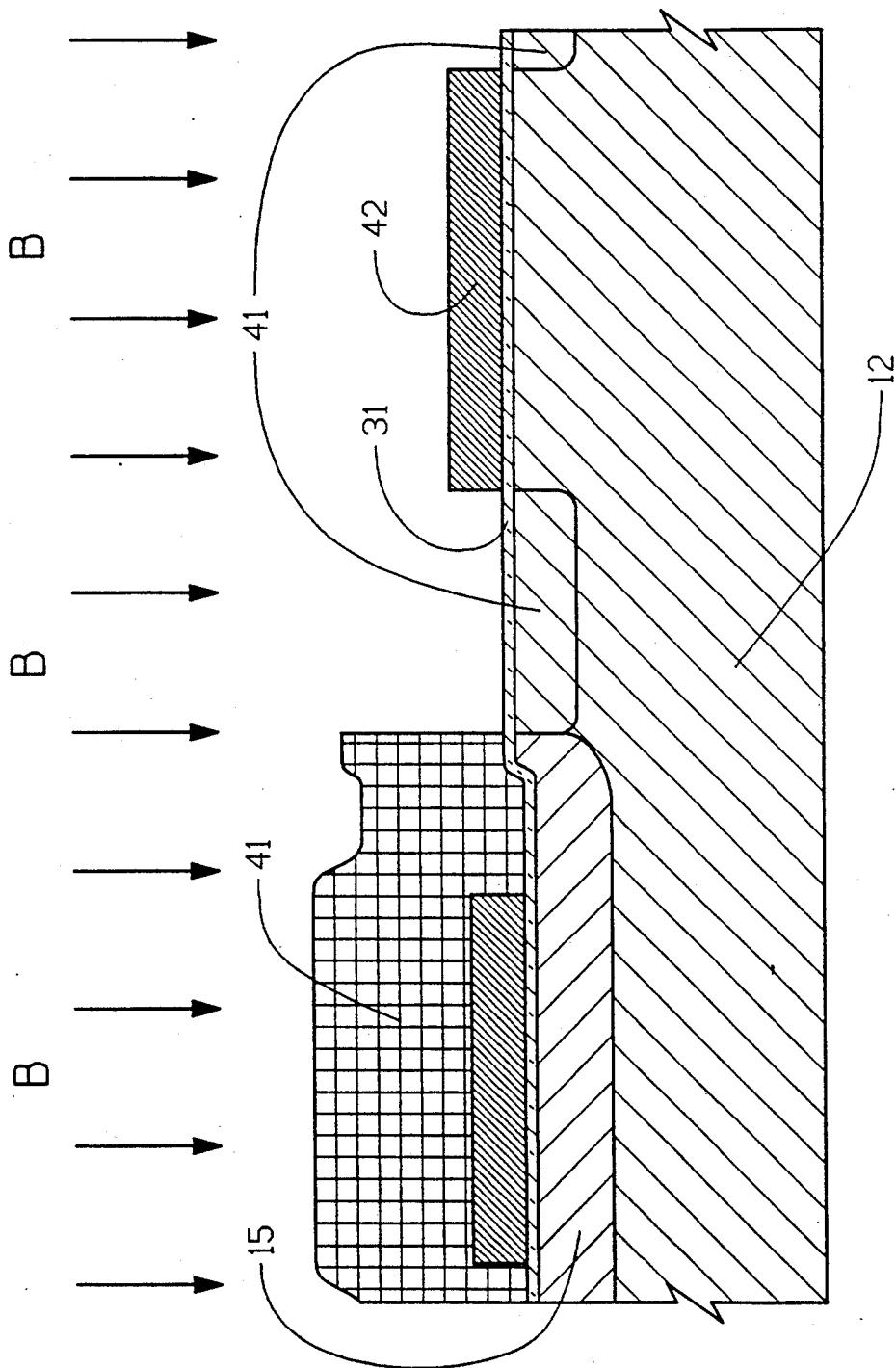

FIG. 4

Explore Litigation Insights

Docket Alarm provides insights to develop a more informed litigation strategy and the peace of mind of knowing you're on top of things.

Real-Time Litigation Alerts



Keep your litigation team up-to-date with **real-time alerts** and advanced team management tools built for the enterprise, all while greatly reducing PACER spend.

Our comprehensive service means we can handle Federal, State, and Administrative courts across the country.

Advanced Docket Research



With over 230 million records, Docket Alarm's cloud-native docket research platform finds what other services can't. Coverage includes Federal, State, plus PTAB, TTAB, ITC and NLRB decisions, all in one place.

Identify arguments that have been successful in the past with full text, pinpoint searching. Link to case law cited within any court document via Fastcase.

Analytics At Your Fingertips



Learn what happened the last time a particular judge, opposing counsel or company faced cases similar to yours.

Advanced out-of-the-box PTAB and TTAB analytics are always at your fingertips.

API

Docket Alarm offers a powerful API (application programming interface) to developers that want to integrate case filings into their apps.

LAW FIRMS

Build custom dashboards for your attorneys and clients with live data direct from the court.

Automate many repetitive legal tasks like conflict checks, document management, and marketing.

FINANCIAL INSTITUTIONS

Litigation and bankruptcy checks for companies and debtors.

E-DISCOVERY AND LEGAL VENDORS

Sync your system to PACER to automate legal marketing.