



US006140226A

# United States Patent [19]

Grill et al.

[11] Patent Number: **6,140,226**

[45] Date of Patent: **Oct. 31, 2000**

[54] **DUAL DAMASCENE PROCESSING FOR SEMICONDUCTOR CHIP INTERCONNECTS**

5,882,996 3/1999 Dai ..... 438/597

### FOREIGN PATENT DOCUMENTS

905768 3/1999 European Pat. Off. .

*Primary Examiner*—Caridad Everhart  
*Attorney, Agent, or Firm*—Robert M. Trepp

[75] Inventors: **Alfred Grill**, White Plains; **John Patrick Hummel**, Millbrook; **Christopher Vincent Jahnes**, Monsey; **Vishnubhai Vitthalbhai Patel**, Yorktown Heights; **Katherine Lynn Saenger**, Ossining, all of N.Y.

[57] **ABSTRACT**

[73] Assignee: **International Business Machines Corporation**, Armonk, N.Y.

The present invention relates to lithographic methods for forming a dual relief pattern in a substrate, and the application of such methods to fabricating multilevel interconnect structures in semiconductor chips by a Dual Damascene process in which dual relief cavities formed in a dielectric are filled with conductive material to form the wiring and via levels. The invention comprises a twice patterned single mask layer Dual Damascene process modified by the addition of an easy-to-integrate sidewall liner to protect organic interlevel and intralevel dielectrics from potential damage induced by photoresist stripping steps during lithographic rework. The invention further comprises a method for forming a dual pattern hard mask which may be used to form dual relief cavities for use in Dual Damascene processing, said dual pattern hard mask comprising a first set of one or more layers with a first pattern, and a second set of one or more layers with a second pattern.

[21] Appl. No.: **09/126,212**

[22] Filed: **Jul. 30, 1998**

### Related U.S. Application Data

[60] Provisional application No. 60/071,628, Jan. 16, 1998.

[51] Int. Cl.<sup>7</sup> ..... **H01L 21/4763**

[52] U.S. Cl. .... **438/637; 438/701; 438/638**

[58] Field of Search ..... 438/637, 636, 438/700, 701, 702, 638, 640

### [56] References Cited

#### U.S. PATENT DOCUMENTS

5,604,156 2/1997 Chung et al. .

**48 Claims, 8 Drawing Sheets**

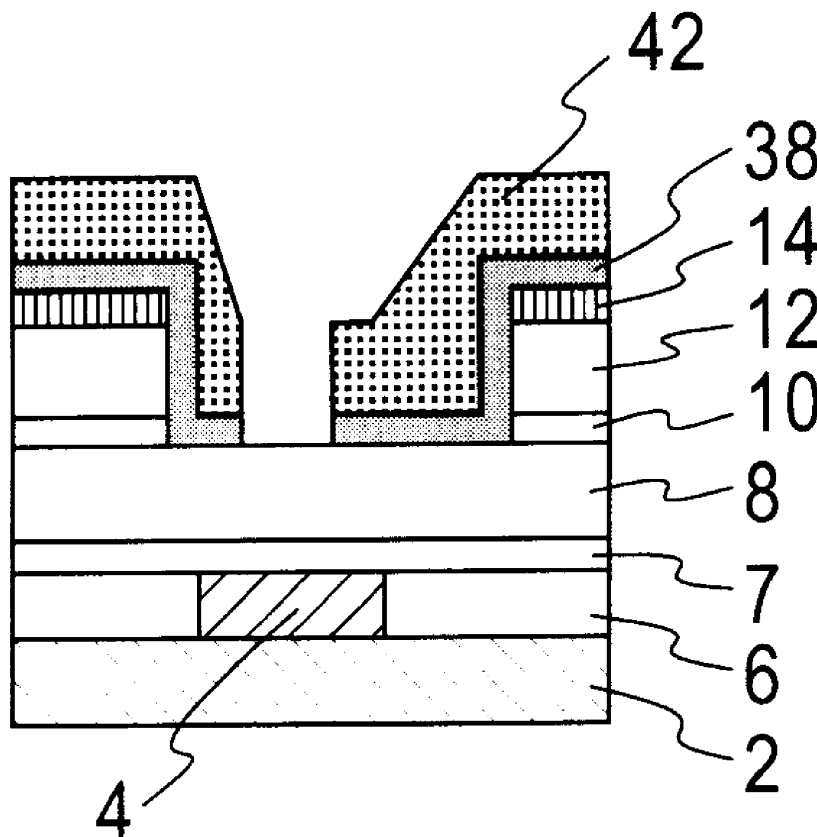

PRIOR ART

Fig. 1A

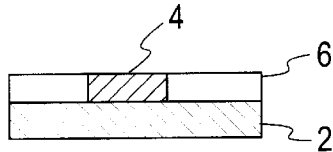

Fig. 1B

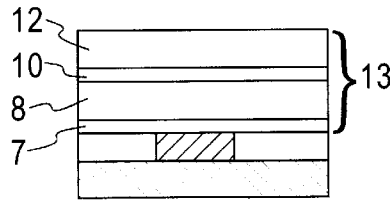

Fig. 1C

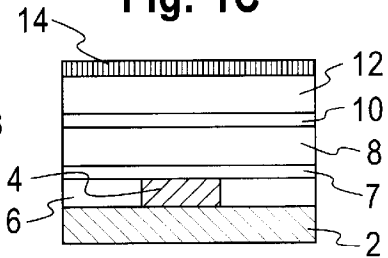

Fig. 1D

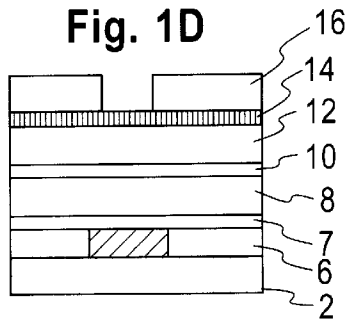

Fig. 1E

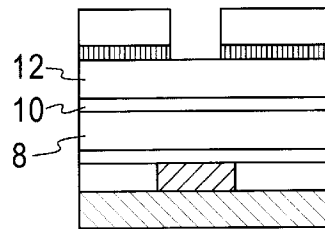

Fig. 1F

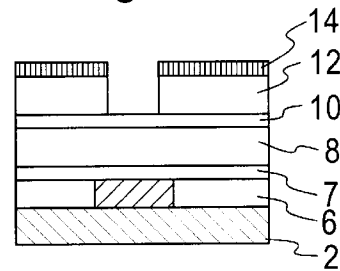

Fig. 1G

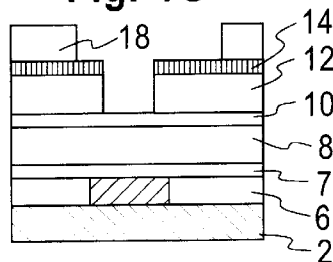

Fig. 1H

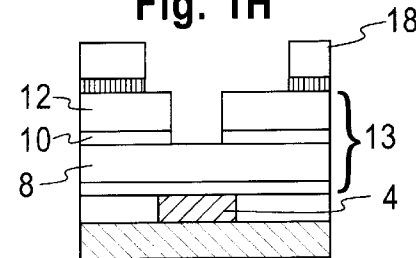

Fig. 1I

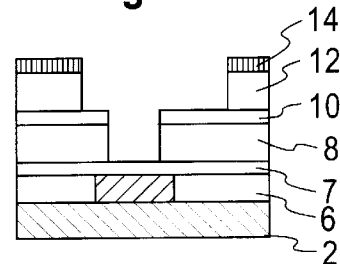

Fig. 1J

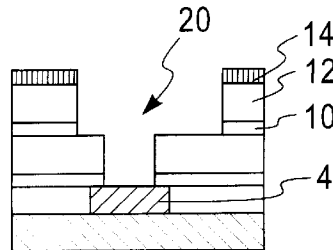

Fig. 1K

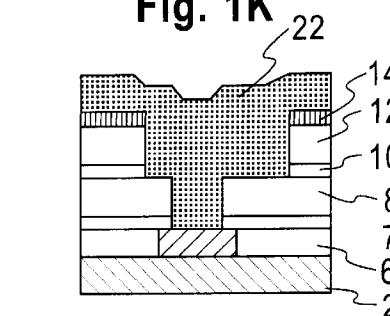

Fig. 1L

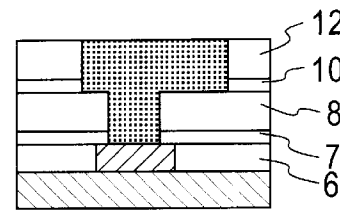

Fig. 2A

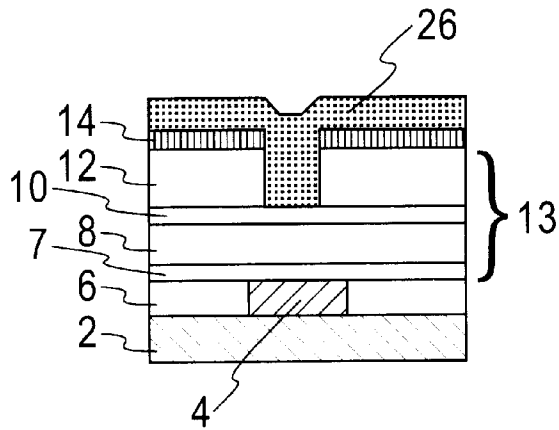

Fig. 2B

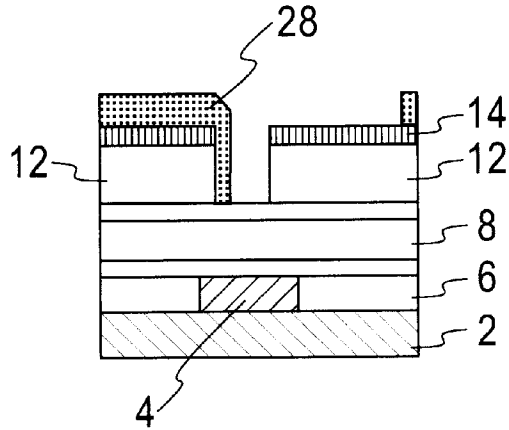

Fig. 2C

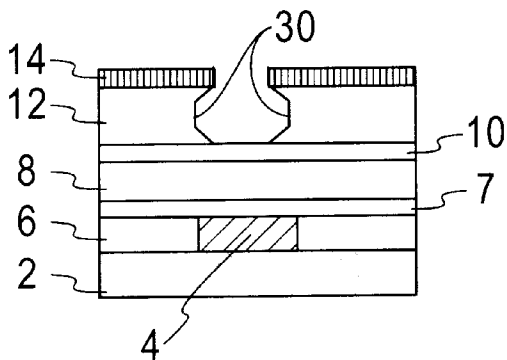
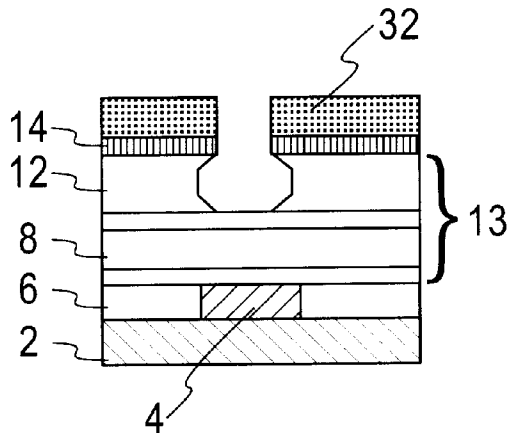

Fig. 2D



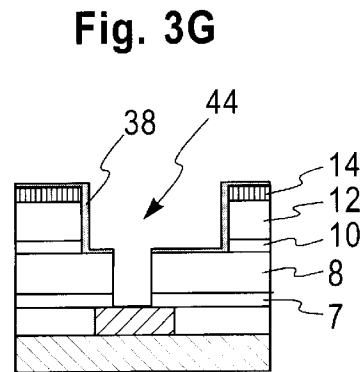
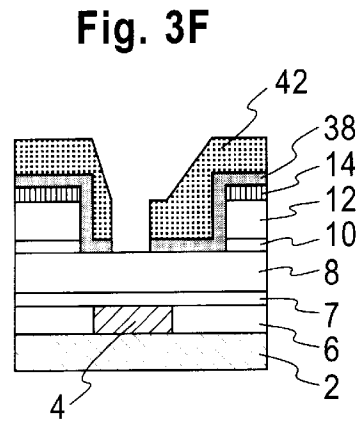
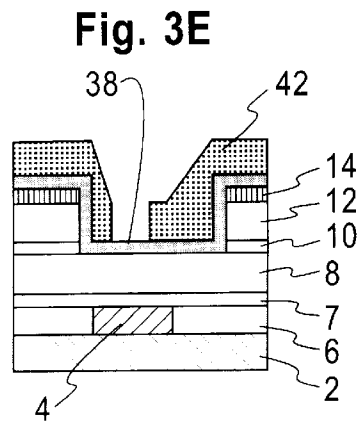
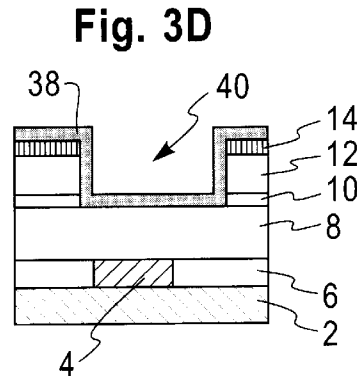
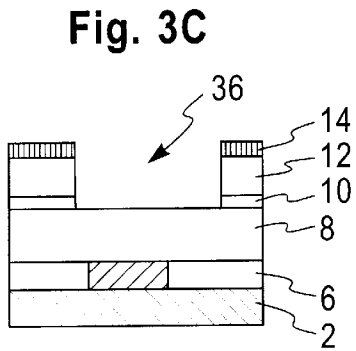
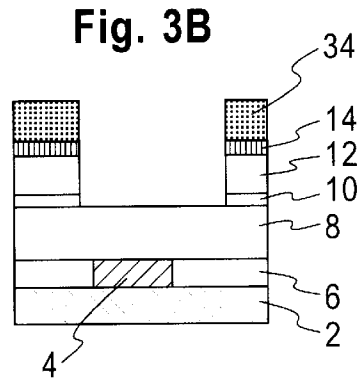
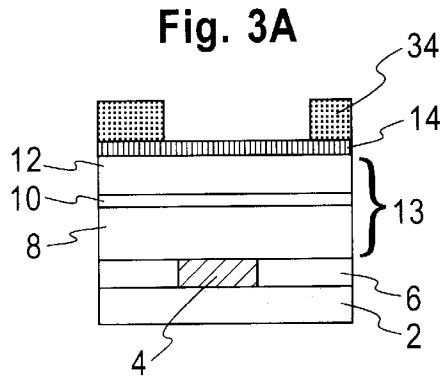

Fig. 4A

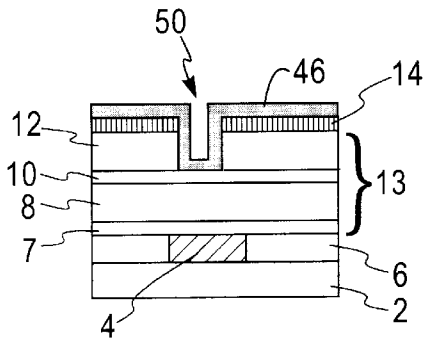

Fig. 4B

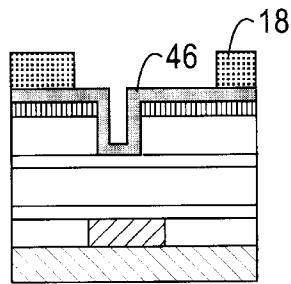

Fig. 4C

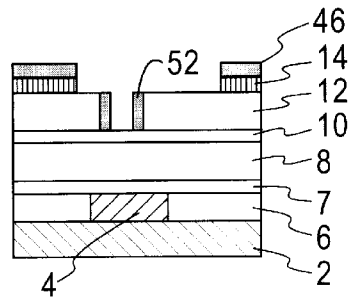

Fig. 4D

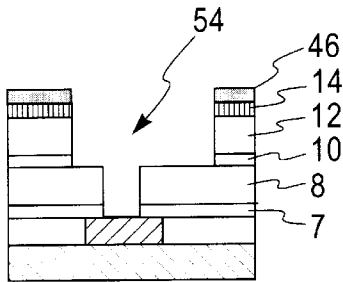

Fig. 4E

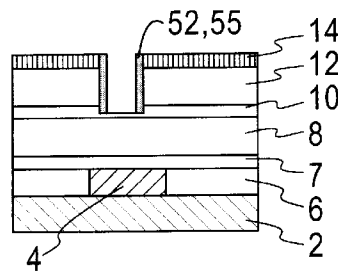
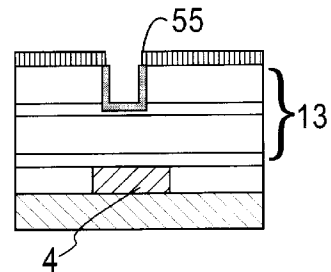

Fig. 4F



# Explore Litigation Insights

Docket Alarm provides insights to develop a more informed litigation strategy and the peace of mind of knowing you're on top of things.

## Real-Time Litigation Alerts



Keep your litigation team up-to-date with **real-time alerts** and advanced team management tools built for the enterprise, all while greatly reducing PACER spend.

Our comprehensive service means we can handle Federal, State, and Administrative courts across the country.

## Advanced Docket Research



With over 230 million records, Docket Alarm's cloud-native docket research platform finds what other services can't. Coverage includes Federal, State, plus PTAB, TTAB, ITC and NLRB decisions, all in one place.

Identify arguments that have been successful in the past with full text, pinpoint searching. Link to case law cited within any court document via Fastcase.

## Analytics At Your Fingertips



Learn what happened the last time a particular judge, opposing counsel or company faced cases similar to yours.

Advanced out-of-the-box PTAB and TTAB analytics are always at your fingertips.

## API

Docket Alarm offers a powerful API (application programming interface) to developers that want to integrate case filings into their apps.

## LAW FIRMS

Build custom dashboards for your attorneys and clients with live data direct from the court.

Automate many repetitive legal tasks like conflict checks, document management, and marketing.

## FINANCIAL INSTITUTIONS

Litigation and bankruptcy checks for companies and debtors.

## E-DISCOVERY AND LEGAL VENDORS

Sync your system to PACER to automate legal marketing.