



US005741626A

United States Patent [19]

Jain et al.

[11] Patent Number: 5,741,626

[45] Date of Patent: Apr. 21, 1998

[54] **METHOD FOR FORMING A DIELECTRIC TANTALUM NITRIDE LAYER AS AN ANTI-REFLECTIVE COATING (ARC)**

[75] Inventors: **Ajay Jain; Kevin Lucas**, both of Austin, Tex.

[73] Assignee: **Motorola, Inc.**, Schaumburg, Ill.

[21] Appl. No.: **632,209**

[22] Filed: **Apr. 15, 1996**

[51] Int. Cl.⁶ **G03F 7/00; H01L 21/314**

[52] U.S. Cl. **430/314; 430/311; 430/312; 430/316; 430/317; 438/626; 438/633; 438/634; 438/636; 438/692; 438/694; 438/703; 438/785; 216/18**

[58] **Field of Search** **430/311, 312, 430/314, 316, 317; 156/652.1, 661.11; 437/229, 195; 216/18; 438/598, 626, 634, 636, 637, 638, 618, 703, 692, 694, 126, 133, 355, 389, 785, 633**

[56] **References Cited**

U.S. PATENT DOCUMENTS

| | | | |
|-----------|--------|-----------------|---------|
| 3,884,698 | 5/1975 | Kakihama et al. | 117/217 |
| 4,374,912 | 2/1983 | Kaneki et al. | 430/5 |
| 4,804,606 | 2/1989 | Ohno et al. | 430/57 |
| 5,091,244 | 2/1992 | Biomard | 428/216 |
| 5,451,543 | 9/1995 | Woo et al. | 438/637 |
| 5,635,423 | 6/1997 | Huang et al. | 438/638 |

FOREIGN PATENT DOCUMENTS

| | | | |
|-----------|--------|--------------------|------------|
| 0661736A1 | 7/1995 | European Pat. Off. | |
| 60-32980 | 2/1985 | Japan | F03G 7/06 |
| 60-55657 | 3/1985 | Japan | H01L 27/04 |
| 63-76325 | 4/1988 | Japan | H01L 21/30 |
| 4-124869 | 4/1992 | Japan | H01L 27/04 |

OTHER PUBLICATIONS

Dan C. Anderson et al., "The Great Static Protection Debate", Australian Electronics Engineering 17(10):52-5 Oct. 1984, 5 pgs.

Yasushiro Fukuda et al., "Electrical Overstress/Electrostatic Discharge", VLSI ESD Phenomenon and Protection—1988 EOS/ESD Symposium Proceedings, pp. 228-234.

"Dual Damascene: A ULSI Wiring Technology," Kaanta, et al.; VMIC Conference, Jun. 11, 1991.

"Chemical Vapor Deposition of Vanadium, Niobium, and Tantalum Nitride Thin Films," Fix, et al.; Chem. Mater, vol. 5, No. 5, 1993.

Primary Examiner—Bernard P. Codd
Attorney, Agent, or Firm—Keith E. Witek

[57] **ABSTRACT**

The present invention provides an anti-reflective Ta₃N₅ coating which can be used in a dual damascene structure and for I line or G line lithographies. In addition, the Ta₃N₅ coating may also be used as an etch stop and a barrier layer. A dual damascene structure is formed by depositing a first dielectric layer (16). A dielectric tantalum nitride layer (18) is deposited on top of the first dielectric layer. A second dielectric layer (20) is deposited on the tantalum nitride layer. A dual damascene opening (34) is etched into the dielectric layers by patterning a first opening portion (26) and a second opening portion (32) using photolithography operations. Dielectric tantalum nitride layer (18) serves as an ARC layer during these operations to reduce the amount of reflectance from conductive region (14) to reduce distortion of the photoresist pattern. The use of a dielectric tantalum nitride layer as an ARC is particularly suitable for I line and G line lithography.

27 Claims, 6 Drawing Sheets

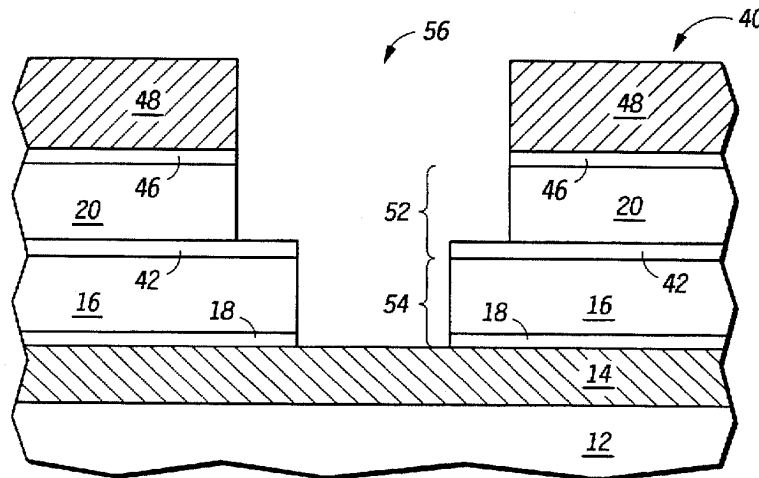

FIG. 1

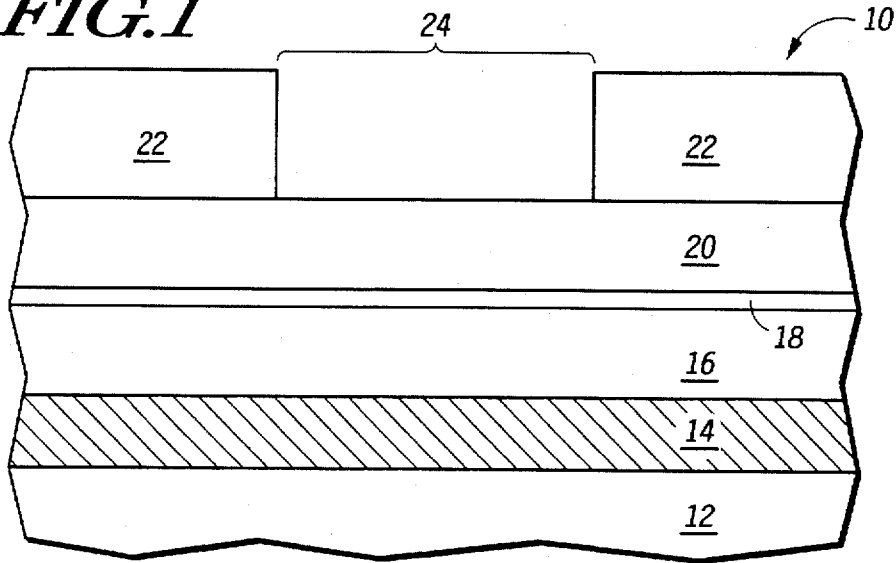

FIG. 2

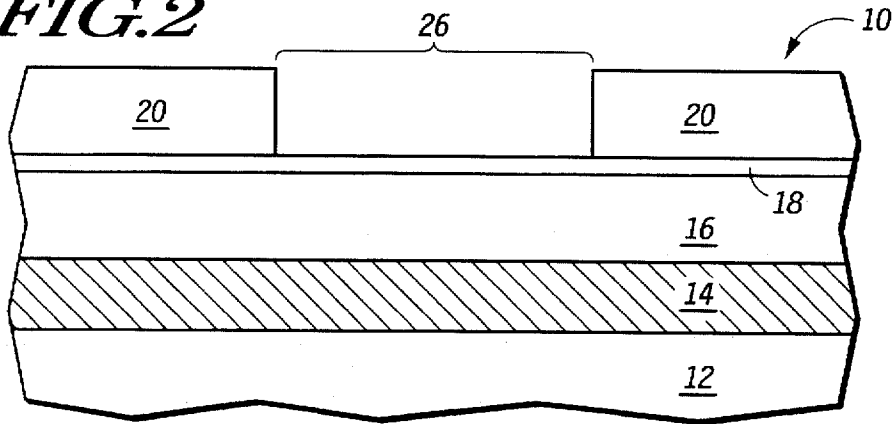
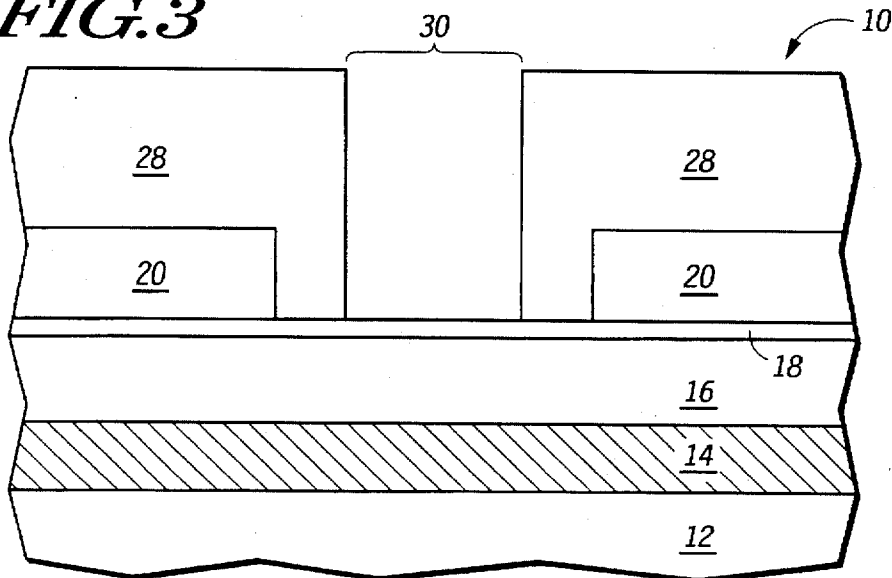
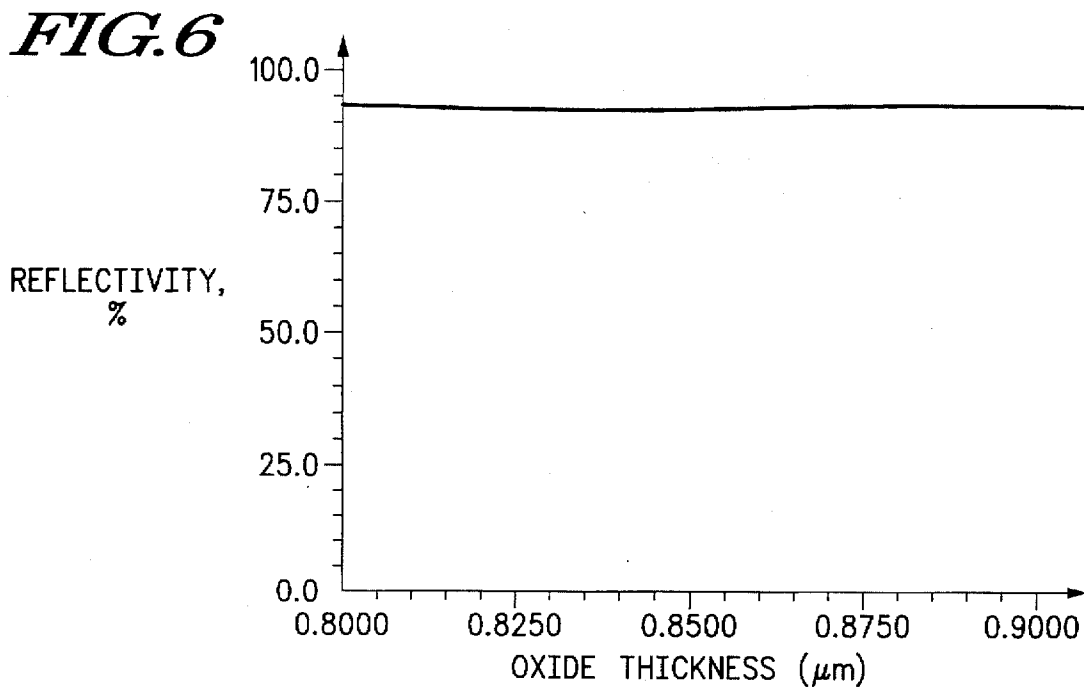
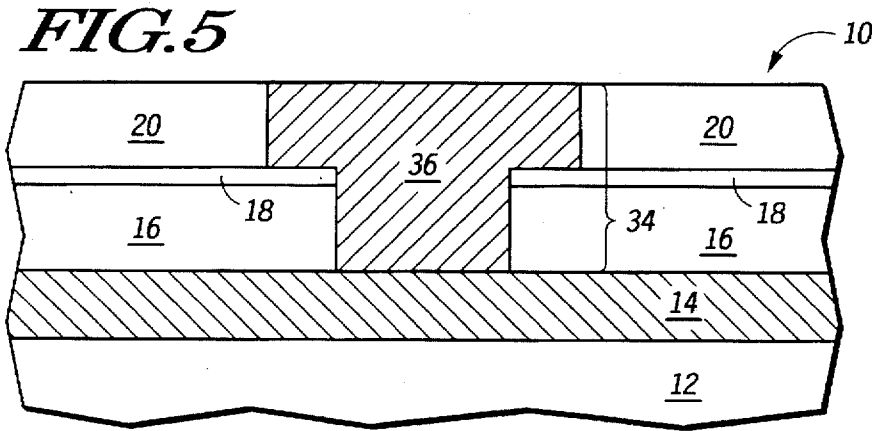
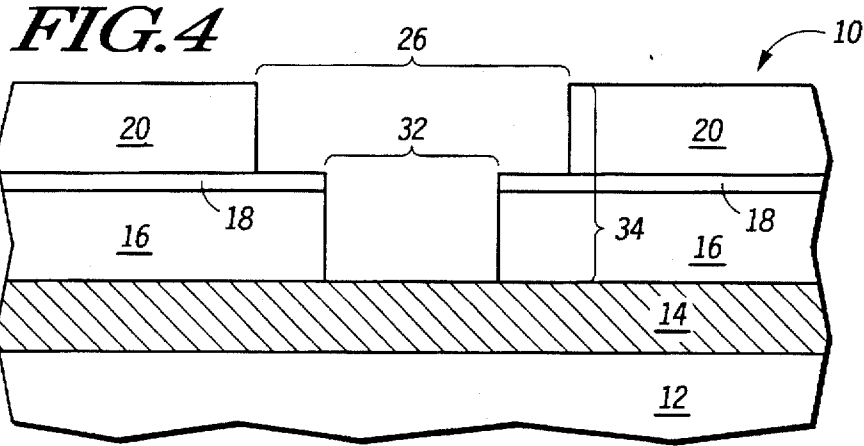

FIG. 3





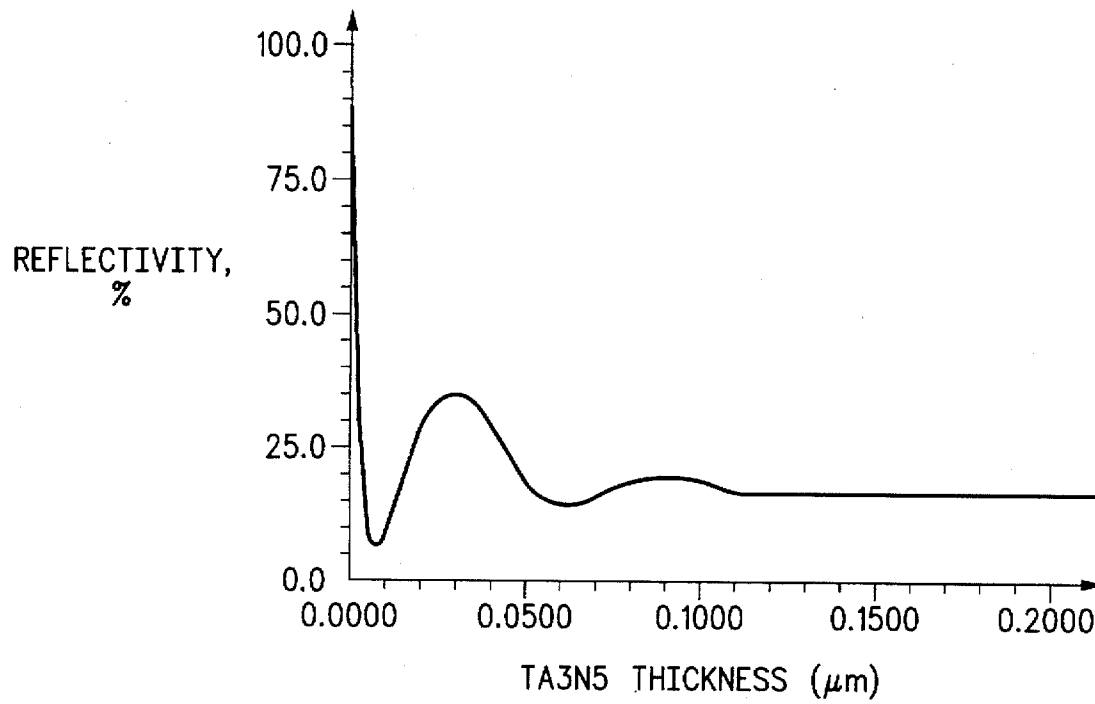

FIG. 7

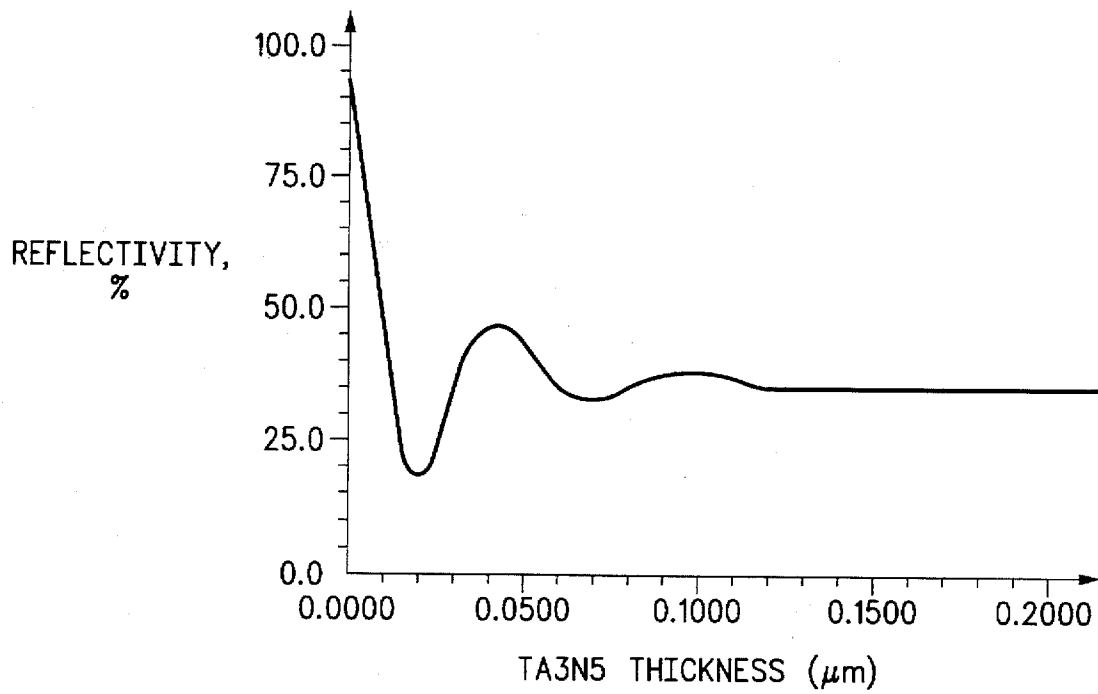

FIG. 8

FIG. 9

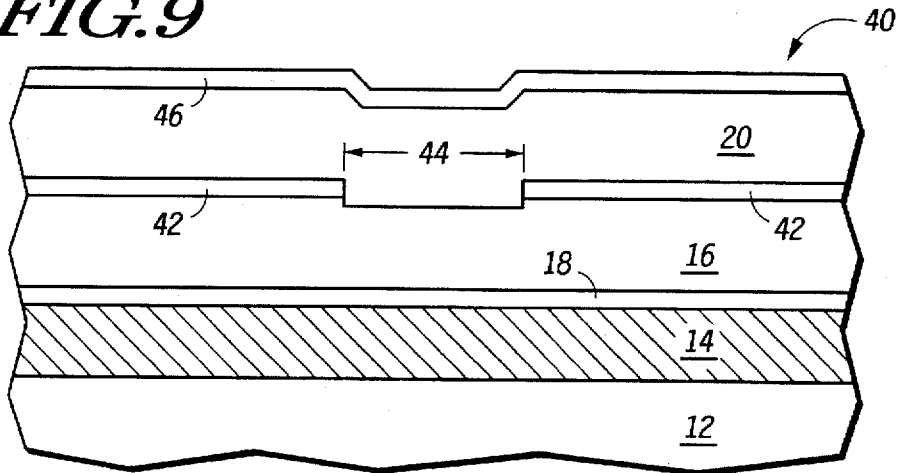

FIG. 10

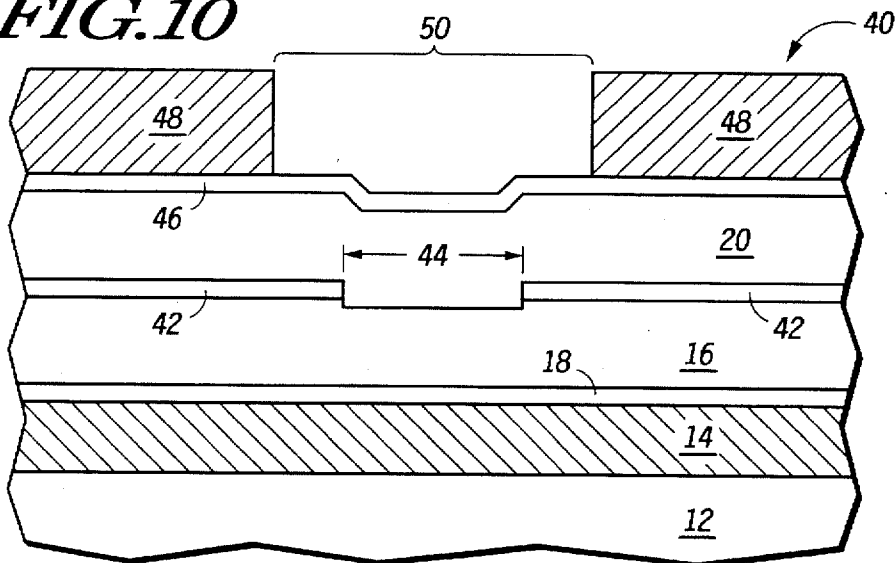
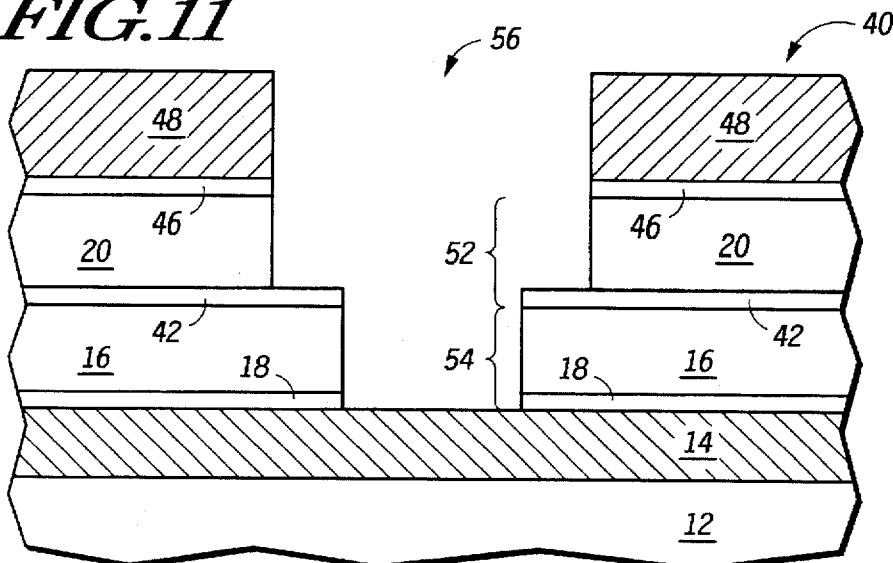

FIG. 11



Explore Litigation Insights

Docket Alarm provides insights to develop a more informed litigation strategy and the peace of mind of knowing you're on top of things.

Real-Time Litigation Alerts



Keep your litigation team up-to-date with **real-time alerts** and advanced team management tools built for the enterprise, all while greatly reducing PACER spend.

Our comprehensive service means we can handle Federal, State, and Administrative courts across the country.

Advanced Docket Research



With over 230 million records, Docket Alarm's cloud-native docket research platform finds what other services can't. Coverage includes Federal, State, plus PTAB, TTAB, ITC and NLRB decisions, all in one place.

Identify arguments that have been successful in the past with full text, pinpoint searching. Link to case law cited within any court document via Fastcase.

Analytics At Your Fingertips



Learn what happened the last time a particular judge, opposing counsel or company faced cases similar to yours.

Advanced out-of-the-box PTAB and TTAB analytics are always at your fingertips.

API

Docket Alarm offers a powerful API (application programming interface) to developers that want to integrate case filings into their apps.

LAW FIRMS

Build custom dashboards for your attorneys and clients with live data direct from the court.

Automate many repetitive legal tasks like conflict checks, document management, and marketing.

FINANCIAL INSTITUTIONS

Litigation and bankruptcy checks for companies and debtors.

E-DISCOVERY AND LEGAL VENDORS

Sync your system to PACER to automate legal marketing.