

UNITED STATES PATENT AND TRADEMARK OFFICE

BEFORE THE PATENT TRIAL AND APPEAL BOARD

ORACLE AMERICA, INC., HP INC., HEWLETT PACKARD
ENTERPRISE CO., AND HP ENTERPRISE SERVICES, LLC,
Petitioner,

v.

REALTIME DATA LLC,
Patent Owner.

Case IPR2016-00374
Patent 8,643,513 B2

Before GEORGIANNA W. BRADEN, J. JOHN LEE, AND JASON J.
CHUNG, *Administrative Patent Judges*.

BRADEN, *Administrative Patent Judge*.

DECISION
Institution of *Inter Partes* Review
37 C.F.R. § 42.108

I. INTRODUCTION

A. Background

Oracle America, Inc. (“Petitioner”) filed a Petition (Paper 2, “Pet.”) to institute an *inter partes* review of claims 1, 2, 4, 6, 11–16, 18–20, and 22 of U.S. Patent No. 8,643,513 B2 (Ex. 1001, “the ’513 patent”). Realtime Data LLC, (“Patent Owner”) timely filed a Preliminary Response (Paper 6, “Prelim. Resp.”). We have jurisdiction under 35 U.S.C. § 314(a), which provides that an *inter partes* review may not be instituted “unless . . . there is a reasonable likelihood that the petitioner would prevail with respect to at least 1 of the claims challenged in the petition.”

Upon consideration of the Petition, the Petitioner’s supporting evidence, and Patent Owner’s Preliminary Response, we conclude Petitioner has established a reasonable likelihood it would prevail with respect to at least one of the challenged claims. Accordingly, for the reasons that follow, we institute an *inter partes* review.

B. Related Proceedings

Petitioner informs us of the following co-pending litigation matters that would affect or could be affected by a decision in this proceeding: *Realtime Data LLC v Actian Corporation et al.*, E.D. Tex. Case No. 6:2015-cv-00463, *Realtime Data LLC v Dropbox, Inc.*, E.D. Tex. Case No. 6:2015-cv-00465, *Realtime Data LLC v EchoStart Corporation et al.*, E.D. Tex. Case No. 6:2015-cv-00466, *Realtime Data LLC v Oracle America, Inc., Hewlett-Packard Co. and HP Enterprise Services, LLC*, E.D. Tex. Case No. 6:2015-cv-00467, *Realtime Data LLC v Riverbed Technology, Inc. et al.*, E.D. Tex. Case No. 6:2015-cv-00468, *Realtime Data LLC v SAP America, Inc. et al.*, E.D. Tex. Case No. 6:2015-cv-00469, *Realtime Data LLC v*

Teradata Corporation et al., E.D. Tex. Case No. 6:2015-cv-00470, all filed on May 8, 2015, and still pending currently. Pet. 3.

Petitioner also informs us of concurrently filed IPR2016-00373 (challenging U.S. Patent No. 7,378,992); IPR2016-00375 (challenging U.S. Patent No. 7,415,530); IPR2016-00376 (challenging U.S. Patent No. 7,415,530); and IPR2016-00377 (challenging U.S. Patent No. 9,116,908). *Id.*

C. The '513 Patent

The '513 patent, titled “Data Compression Method and System,” discloses systems and methods for analyzing a data block and selecting a compression method to apply to that block. Ex. 1001, Title, Abst. The '513 patent further discloses “fast and efficient data compression using a combination of content independent data compression and content dependent data compression.” *Id.* at 3:55–58. One embodiment of the '513 patent is illustrated in Figure 13A reproduced below.

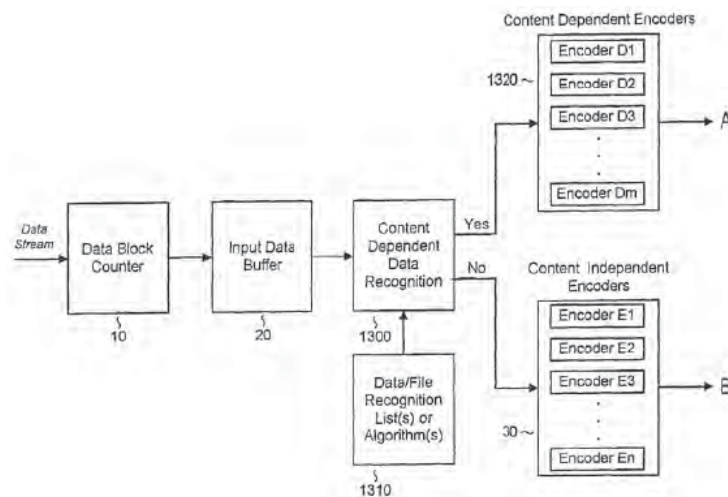

As shown above in Figure 13A of the '513 patent, the system receives an input data stream of data blocks. *Id.* at 15:63–16:5. Content dependent data recognition module 1300 analyzes the incoming data stream to recognize

“data types” and other parameters indicative of the “data type/content.” *Id.* at 16:15–21. If module 1300 recognizes the data type of a given data block, module 1300 routes the block to content dependent encoder module 1320 (*id.* at 16:24–26); if not, it routes the block to “content independent” (or “default”) encoder module 30 (*id.* at 3:66–67, 4:30–35, 15:56–63, 16:26–27, 18:17–25).

Content dependent encoder module 1320 comprises lossy or lossless compression encoders (*id.* at 16:28–37); content independent encoder module 30 comprises only lossless encoders (*id.* at 16:43–50). Lossy encoders provide for an “inexact” representation of the original uncompressed data (*id.* at 2:4–7); lossless encoders provide for an “exact” representation (*id.* at 2:18–20). The ’513 patent teaches that “[e]ncoding techniques” may be selected “based upon their ability to effectively encode different types of input data.” *Id.* at 12:54–56.

Another embodiment of the ’513 patent is illustrated in Figure 13B reproduced below.

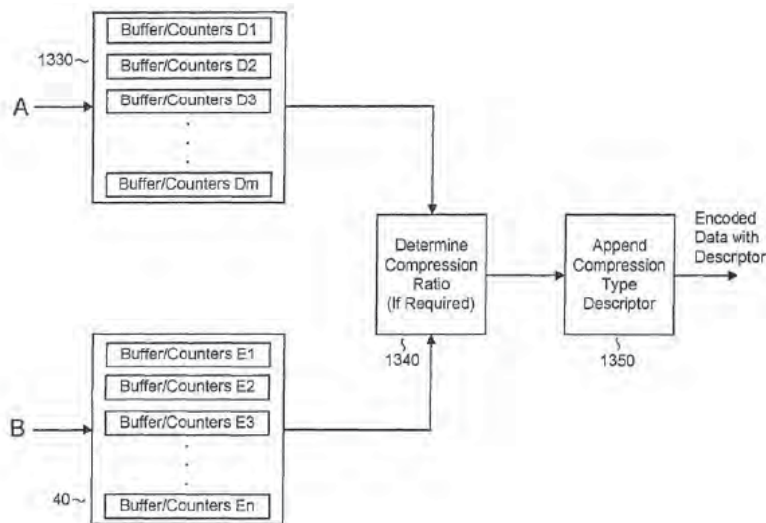

As shown above in Figure 13B of the ’513 patent, “compression ratio module 1340, operatively connected to the content dependent output

builder/counters 1330 and content independent buffer/counters 40 determines the compression ratio obtained for each of the enabled encoders E1 . . . En.” *Id.* at 17:28–42. The compression ratio is set “by taking the ratio of the size of the input data block to the size of the output data block stored in the corresponding buffer/counters BCD1, BCD2, BCD3 . . . BCDm and/or BCE1, BCE2, BCE3 . . . BCEn.” *Id.* at 17:39–42

D. Challenged Claims

As noted above, Petitioner challenges claims 1, 2, 4, 6, 11–16, 18–20, and 22 of the ’513 patent, of which claims 1 and 15 are the only independent claims. Claims 1 and 15 are representative of the challenged claims and are reproduced below (with paragraphing):

1. A method of compressing a plurality of data blocks, comprising:

analyzing the plurality of data blocks to recognize when an appropriate content independent compression algorithm is to be applied to the plurality of data blocks;

applying the appropriate content independent data compression algorithm to a portion of the plurality of data blocks to provide a compressed data portion;

analyzing a data block from another portion of the plurality of data blocks for recognition of any characteristic, attribute, or parameter that is indicative of an appropriate content dependent algorithm to apply to the data block; and

applying the appropriate content dependent data compression algorithm to the data block to provide a compressed data block when the characteristic, attribute, or parameter is identified,

wherein the analyzing the plurality of data blocks to recognize when the appropriate content independent compression algorithm is to be applied excludes analyzing based only on a descriptor indicative of the any characteristic, attribute, or parameter, and

Explore Litigation Insights

Docket Alarm provides insights to develop a more informed litigation strategy and the peace of mind of knowing you're on top of things.

Real-Time Litigation Alerts



Keep your litigation team up-to-date with **real-time alerts** and advanced team management tools built for the enterprise, all while greatly reducing PACER spend.

Our comprehensive service means we can handle Federal, State, and Administrative courts across the country.

Advanced Docket Research



With over 230 million records, Docket Alarm's cloud-native docket research platform finds what other services can't. Coverage includes Federal, State, plus PTAB, TTAB, ITC and NLRB decisions, all in one place.

Identify arguments that have been successful in the past with full text, pinpoint searching. Link to case law cited within any court document via Fastcase.

Analytics At Your Fingertips



Learn what happened the last time a particular judge, opposing counsel or company faced cases similar to yours.

Advanced out-of-the-box PTAB and TTAB analytics are always at your fingertips.

API

Docket Alarm offers a powerful API (application programming interface) to developers that want to integrate case filings into their apps.

LAW FIRMS

Build custom dashboards for your attorneys and clients with live data direct from the court.

Automate many repetitive legal tasks like conflict checks, document management, and marketing.

FINANCIAL INSTITUTIONS

Litigation and bankruptcy checks for companies and debtors.

E-DISCOVERY AND LEGAL VENDORS

Sync your system to PACER to automate legal marketing.