

LINDA HALL LIBRARY
5109 CHERRY STREET
KANSAS CITY, MISSOURI
64110-2498

PHONE (816) 363-4600
FAX: (816) 926-8785

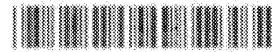

6/13/13 DocServ #: 702678

SUPER RUSH

12:54

SHIP TO:

027019
Attn: Goodwin Procter
Goodwin Procter
53 State Street
Floor 23, Library
Boston MA 02109
US

Shelved as:

Location:

Title: IEEE Standard 802.3

Volume:

Issue:

Date: 1993

Author:

Article Title:

Pages:

294

Accept Non English? No

Fax: 617-523-1231
Phone: 617-305-6868
Ariel:
Email: ill@goodwinprocter.com

Super

ElecDel

LHL

SupplierWillPay

Max Cost: \$150

Reference Number: #100790-212511

Account Number:

FEDEX Account Number:

Notes: Please direct any questions to:
Brooke Raymond 212-459-7463

PG/IEEE
\$32.50
C

DOCSERV / WEB / PULL SLIP

402A

LIBRARY
AT TRANSANOIDS
CONCORD

INTERNATIONAL STANDARD

ISO/IEC

IEEE

8802-3

ANSI/IEEE

Std 802.3

SPECIFICATION

Fourth edition
1993-07-08

AUG 5 1993

LINDA HALL LIBRARY

FOR SUPPLEMENTS
SEE:

IEEE 802.3U
1995
IEEE 802.3Z
1993

IEEE 802.3P-1993

Information technology — Local and metropolitan area networks —

Part 3:

Carrier sense multiple access with collision detection
(CSMA/CD) access method and physical layer
specifications

Technologie de l'information — Réseaux locaux et métropolitains —

*Partie 3: Accès multiple par surveillance du signal et détection de collision et
spécifications pour le couche physique*



Reference number
ISO/IEC 8802-3:1993 (E)
ANSI/IEEE
Std 802.3, 1993 Edition

The Institute of Electrical and Electronics Engineers, Inc.
345 East 47th Street, New York, NY 10017-2396, USA

Copyright © 1993 by the
Institute of Electrical and Electronics Engineers, Inc.
All rights reserved. Published 1993
Printed in the United States of America

ISBN 1-55807-324-3

*No part of this publication may be reproduced in any form,
in an electronic retrieval system or other means,
without the prior written permission of the publisher.*

July 8, 1993

SH16317

International Standard ISO/IEC 8802-3 : 1993
ANSI/IEEE Std 802.3, 1993 Edition

(This edition contains ANSI/IEEE Std 802.3-1985,
ANSI/IEEE Std 802.3c-1985, ANSI/IEEE Std 802.3d-1987,
ANSI/IEEE Std 802.3b-1985, ANSI/IEEE Std 802.3e-1987,
ANSI/IEEE Std 802.3h-1990, ANSI/IEEE Std 802.3i-1990, and
corrections resulting from Maintenance Ballot #1.)

Information technology—
Local and metropolitan area networks—

Part 3:
Carrier sense multiple access with
collision detection (CSMA/CD)
access method and
physical layer specifications

Sponsor

Technical Committee on Computer Communications
of the
IEEE Computer Society

Abstract: This Local and Metropolitan Area Network standard, ISO/IEC 8802-3 : 1993 [ANSI/IEEE Std 802.3, 1993 Edition], specifies the media access control characteristics for the Carrier Sense Multiple Access with Collision Detection (CSMA/CD) access method. It also specifies the media, Medium Attachment Unit (MAU) and physical layer repeater unit for 10 Mb/s baseband and broadband systems, and it provides a 1 Mb/s baseband implementation. Specifications for MAU types 10BASE5, 10BASE2, FOIRL (fiber optic inter-repeater link), 10BROAD36, 1BASE5, and 10BASE-T are included. System considerations for multisegment 10 Mb/s baseband networks are provided. Layer and sublayer interface specifications are aligned to the ISO Open Systems Interconnection Basic Reference Model and 8802 models. The 8802-3 internal model is defined and used.

Keywords: data processing, information interchange, local area networks, mode of data transmission, network interconnection, models



Adopted as an International Standard by the
International Organization for Standardization
and by the
International Electrotechnical Commission



Published by
The Institute of Electrical and Electronics Engineers, Inc.

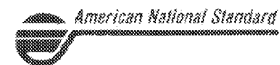

International Standard ISO/IEC 8802-3 : 1993

ISO (the International Organization for Standardization) and IEC (the International Electrotechnical Commission) form the specialized system for worldwide standardization. National bodies that are members of ISO or IEC participate in the development of International Standards through technical committees established by the respective organization to deal with particular fields of technical activity. ISO and IEC technical committees collaborate in fields of mutual interest. Other international organizations, governmental and nongovernmental, in liaison with ISO and IEC, also take part in the work.

In the field of information technology, ISO and IEC have established a joint technical committee, ISO/IEC JTC 1. Draft International Standards adopted by the joint technical committee are circulated to national bodies for voting. Publication as an International Standard requires approval by at least 75% of the national bodies casting a vote.

In 1985, IEEE Standard 802.3-1985 was adopted by ISO Technical Committee 97, *Information processing systems*, as draft International Standard ISO/DIS 8802-3. Following the procedures described above, the Standard was subsequently approved by ISO and published as ISO 8802-3 : 1989, incorporating ISO 8802-3/DAD 1 which had resulted from the adoption by ISO in 1987 of ANSI/IEEE Std 802.3a.

A further revision was subsequently approved by ISO/IEC JTC 1 in 1990, incorporating ISO/IEC 8802-3/Amendments 2 and 5.

A third edition, published in 1992, incorporated ISO/IEC 8802-3/Amendments 3 and 4.

This fourth edition cancels and replaces ISO/IEC 8802-3 : 1992 and incorporates ISO/IEC 8802-3/Amendment 6, *Maintenance Ballot*; Amendment 7, *Layer management*; and Amendment 9, *System considerations for multisegment 10 Mb/s baseband networks and Twisted-pair medium attachment unit (MAU) and baseband medium, type 10BASE-T*. These amendments were approved in 1992.

For the purpose of assigning organizationally unique identifiers, the Institute of Electrical and Electronics Engineers, Inc., USA, has been designated by the ISO Council as the Registration Authority. Communications on this subject should be addressed to

Registration Authority for ISO/IEC 8802-3
c/o The Institute of Electrical and Electronics Engineers, Inc.
445 Hoes Lane
P.O. Box 1331
Piscataway, NJ 08855-1331
USA

During the preparation of this International Standard, information was gathered on patents upon which application of this standard might depend. Relevant patents were identified as belonging to Xerox Corporation. However, ISO and IEC cannot give authoritative or comprehensive information about evidence, validity or scope of patent and like rights. The patent-holder has stated that licenses will be granted under reasonable terms and conditions and communications on this subject should be addressed to

Xerox Corporation
P.O. Box 1600
Stamford, CT 06904
USA



International Organization for Standardization/International Electrotechnical Commission
Case postale 56 • CH-1211 Genève 20 • Switzerland

Foreword to International Standard ISO/IEC 8802-3 : 1993

This standard is part of a family of standards for Local and Metropolitan Area Networks. The relationship between this standard and the other members of the family is shown below. (The numbers in the figure refer to ISO standard numbers.)

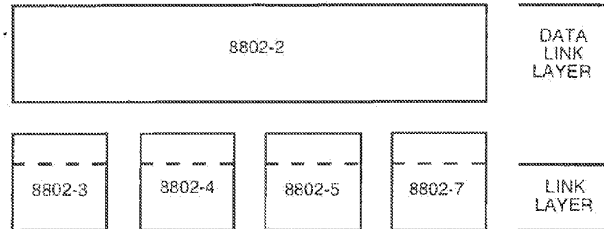

This family of standards deals with the Physical and Data Link layers as defined by the ISO Open Systems Interconnection Basic Reference Model (ISO 7498 : 1984). The access standards define four types of medium access technologies and associated physical media, each appropriate for particular applications or system objectives. Other types are under investigation.

The standards defining these technologies are as follows:

- (1) ISO/IEC 8802-3 [ANSI/IEEE Std 802.3, 1993 Edition], a bus utilizing CSMA/CD as the access method,
- (2) ISO/IEC 8802-4 [ANSI/IEEE Std 802.4-1990], a bus utilizing token passing as the access method,
- (3) ISO/IEC 8802-5 [ANSI/IEEE Std 802.5-1992], a ring utilizing token passing as the access method,
- (4) ISO 8802-7, a ring utilizing slotted ring as the access method.

ISO 8802-2 [ANSI/IEEE Std 802.2-1989], *Logical Link Control protocol*, is used in conjunction with the medium access standards.

ISO/IEC 10038 [ANSI/IEEE Std 802.1D, 1993 Edition], *Media access control (MAC) bridges*, specifies an architecture and protocol for the interconnection of IEEE 802 LANs below the MAC service boundary.

The reader of this document is urged to become familiar with the complete family of standards.

The main body of this standard serves for both the ISO/IEC 8802-3 and ANSI/IEEE Std 802.3 standards. ISO/IEC and IEEE each have unique foreword sections. The Annex applies to the IEEE standard only. The Appendixes serve as useful reference material to both standards.

ANSI/IEEE Std 802.3, 1993 Edition

IEEE Standards documents are developed within the Technical Committees of the IEEE Societies and the Standards Coordinating Committees of the IEEE Standards Board. Members of the committees serve voluntarily and without compensation. They are not necessarily members of the Institute. The standards developed within IEEE represent a consensus of the broad expertise on the subject within the Institute as well as those activities outside of IEEE which have expressed an interest in participating in the development of the standard.

Use of an IEEE Standard is wholly voluntary. The existence of an IEEE Standard does not imply that there are no other ways to produce, test, measure, purchase, market, or provide other goods and services related to the scope of the IEEE Standard. Furthermore, the viewpoint expressed at the time a standard is approved and issued is subject to change brought about through developments in the state of the art and comments received from users of the standard. Every IEEE Standard is subjected to review at least once every five years for revision or reaffirmation. When a document is more than five years old, and has not been reaffirmed, it is reasonable to conclude that its contents, although still of some value, do not wholly reflect the present state of the art. Users are cautioned to check to determine that they have the latest edition of any IEEE Standard.

Comments for revision of IEEE Standards are welcome from any interested party, regardless of membership affiliation with IEEE. Suggestions for changes in documents should be in the form of a proposed change of text, together with appropriate supporting comments.

Interpretations: Occasionally questions may arise regarding the meaning of portions of standards as they relate to specific applications. When the need for interpretations is brought to the attention of IEEE, the Institute will initiate action to prepare appropriate responses. Since IEEE Standards represent a consensus of all concerned interests, it is important to ensure that any interpretation has also received the concurrence of a balance of interests. For this reason IEEE and the members of its technical committees are not able to provide an instant response to interpretation requests except in those cases where the matter has previously received formal consideration.

Comments on standards and requests for interpretations should be addressed to:

Secretary, IEEE Standards Board
345 East 47th Street
New York, NY 10017
USA

IEEE Standards documents are adopted by the Institute of Electrical and Electronics Engineers without regard to whether their adoption may involve patents on articles, materials, or processes. Such adoptions does not assume any liability to any patent owner, nor does it assume any obligation whatever to parties adopting the standards documents.

Foreword to ANSI/IEEE Std 802.3, 1993 Edition

(This Foreword is not a part of this International Standard or of ANSI/IEEE 802.3, 1993 Edition.)

This standard is part of a family of standards for local and metropolitan area networks. The relationship between the standard and other members of the family is shown below. (The numbers in the figure refer to IEEE standard numbers.)

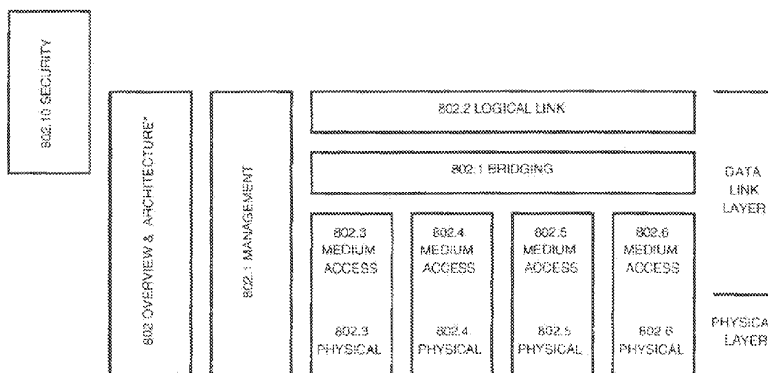

* Formerly IEEE Std 802.1A.

This family of standards deals with the Physical and Data Link layers as defined by the International Organization for Standardization (ISO) Open Systems Interconnection Basic Reference Model (ISO 7498 : 1984). The access standards define several types of medium access technologies and associated physical media, each appropriate for particular applications or system objectives. Other types are under investigation.

The standards defining these technologies are as follows:

- IEEE Std 802[†]: Overview and Architecture. This standard provides an overview to the family of IEEE 802 standards. This document forms part of the 802.1 scope of work.
- IEEE Std 802.1B: LAN/MAN Management. Defines an Open System Interconnection (OSI) management-compatible architecture, and services and protocol elements for use in a LAN/MAN environment for performing remote management.
- ISO/IEC 10038 : 1993 [ANSI/IEEE Std 802.1D] MAC Bridging. Specifies an architecture and protocol for the interconnection of IEEE 802 LANs below the MAC service boundary.
- IEEE Std 802.1E: System Load Protocol. Specifies a set of services and protocol for those aspects of management concerned with the loading of systems on IEEE 802 LANs.
- ISO 8802-2 [ANSI/IEEE Std 802.2]: Logical Link Control
- ISO/IEC 8802-3 [ANSI/IEEE Std 802.3]: CSMA/CD Access Method and Physical Layer Specifications

[†]The 802 Architecture and Overview Specification, originally known as IEEE Std 802.1A, has been renumbered as IEEE Std 802. This has been done to accommodate recognition of the base standard in a family of standards. References to IEEE Std 802.1A should be considered as references to IEEE Std 802.

- ISO/IEC 8802-4 [ANSI/IEEE Std 802.4]: Token Bus Access Method and Physical Layer Specifications
- ISO/IEC 8802-5 [ANSI/IEEE Std 802.5]: Token Ring Access Method and Physical Layer Specifications
- IEEE Std 802.6: Metropolitan Area Network Access Method and Physical Layer Specifications
- IEEE Std 802.10: Interoperable Local Area Network Security, *Currently Contains Secure Data Exchange (SDE)*

In addition to the family of standards the following is a recommended practice for a common technology:

- IEEE Std 802.7: IEEE Recommended Practice for Broadband Local Area Networks

The reader of this document is urged to become familiar with the complete family of standards.

Conformance Test Methodology

Another standards series, identified by the number 1802, has been established to identify the conformance test methodology documents for the 802 family of standards. This makes the correspondence between the various 802 standards and their applicable conformance test requirements readily apparent. Thus the conformance test documents for 802.3 are numbered 1802.3, the conformance test documents for 802.5 will be 1802.5, and so on. Similarly, ISO will use 18802 to number conformance test standards for 8802 standards.

ISO/IEC 8802-3 : 1993 (ANSI/IEEE Std 802.3, 1993 Edition)

This edition of the standard defines 10 Mb/s baseband and broadband implementations and a 1 Mb/s baseband implementation of the Physical Layer using the CSMA/CD access method. It is anticipated that future editions of the standard may provide additional implementations of the physical layer to support different needs (for example, media, and data rates).

This standard contains state-of-the-art material. The area covered by this standard is undergoing evolution. Revisions are anticipated to this standard within the next few years to clarify existing material, to correct possible errors, and to incorporate new related material.

Readers wishing to know the state of revisions should contact

Secretary
 IEEE Standards Board
 Institute of Electrical and Electronics Engineers, Inc
 PO Box 1331, 445 Hoes Lane
 Piscataway, NJ 08855-1331
 USA

The IEEE 802.3 Working Group acknowledges and appreciates that many concepts embodied in this standard are based largely upon the CSMA/CD access method earlier described in *The Ethernet* specification as written jointly by individuals from Xerox Corporation, Digital Equipment Corporation, and Intel Corporation. Appreciation is also expressed to Robert M. Metcalfe and David R. Boggs for their pioneering work in establishing the original concepts.

Participants

When the IEEE 802.3 Working Group approved the original standard (ANSI/IEEE Std 802.3-1985) in 1983, it had the following membership:

Donald C. Loughry, *Chair*

Phil L. Arst
Robert F. Bridge
Charles Brill
G. J. Clancy
John Davidson
Ralph DeMent
Hank (H. N.) Dorris
Judith Estrin
Richard Fabbri
Ingrid Fromm
Milton C. Harper
Bryan Hoover
George D. Jelatis
Harold W. Katz

Donald E. Kotas
William P. Lidinsky
Laurie Lindsey
William D. Livingston
Andy Luque
Daniel Maltbie
Jerry McDowell
C. Kenneth Miller
Robert L. Morrell
Wendell Nakamine
W. P. Neblett
James Nelson
Thomas L. Phinney
David Potter

Robert S. Printis
Gary S. Robinson
Robert Rosenthal
Gary Stephens
Daniel P. Stokesberry
Ken. F. Sumner
Daniel Sze
Victor J. Tarasov
P. E. Wainwright
Lyle Weiman
Hugh E. White
Choa-Ping Wu
Nick Zades
Mo R. Zonoun

Additional individuals who contributed actively in the development of the original standard (ANSI/IEEE Std 802.3-1985) throughout its elaboration were

Juan Bulnes
Ron Crane
Dane Elliot
Alan Flatman
Maris Graube
Guy Harkins

Dean Lindsay
Then. T. Liu
Robert Moles
Tony Lauck
Joseph St. Amand
Richard Seifert
Nathan Tobol

Mark Townsend
Roger Van Brunt
Bo Vicklund
Chris Wargo
Richard Williams
Ron Yara

The ECMA TC24 Committee on Communication Protocols also provided helpful input in the development of this standard.

When the IEEE 802.3 Working Group approved ANSI/IEEE Std 802.3a-1988 (Section 10) in November 1984, it had the following membership:

Donald C. Loughry, *Chair*

Alan Flatman, *Chair, Type 10BASE2 Task Force*

Menachem Abraham
R. V. Balakrishnan
William Belknap
Charles Brill
Juan Bulnes
Stephen Cooper
Ronald Crane
John Davidson
Mark Devon
Phil Edholm
Gregory Ennis
Judy Estrin
Richard Fransen
Ingrid Fromm
Robert Gahn
Rich Graham

Guy Harkins
Greg Hopkins
Joe Kennedy
Hiroshi Kobayashi
Tony Lauck
William Livingston
Hugh Logan
Leland Long
Andy Luque
Daniel Maltbie
Steven Moustakas
Wendell Nakamine
Lloyd Oliver
Aidan Paul
David Potter
Eugene Reilly

Joseph Rickert
Gary Robinson
Robert Rosenthal
Joseph St. Amand
Walter Schreuer
Stephen Soto
Gary Spencer
Robert Summers
Pat Thaler
Geoff Thompson
Wendell Turner
David White
Lawrence White
Rich Williams
Ronald Yara
Mo Zonoun

The following persons were on the balloting committee that approved ANSI/IEEE Std 802.3-1985 for submission to the IEEE Standards Board:

W. Adams
R. Appleby
G. Arnold
Y. Baeg
E. Beauregard
J. Becker
E. Bergaimini
Boerstyn
A. Carrato
G. Carson
S. Chakradarti
S. Chandra
F. Chang
C. Chao
C. Chen
P. Chen
K. Chen
R. Chow
G. Cinque
I. Cotton
D. Cox
R. DeJardins
D. Dickel
C. Eldridge
P. Enslow
J. Fendrich
M. Figuereu
D. Fisher
J. Fletcher
W. Franta
R. Gagliano
D. Gan
M. Graube
M. Greene
R. Gustin
K. Harbaugh
G. Harkins

R. Harrington
H. Heilborn
L. Heselt
D. Hislop
C. Hobbs
S. Hollander
P. Hutton
P. Indriago
T. Ishida
J. Jeleneashy
O. Kahn
S. Kak
K. Katzeff
C. Kessler
D. Kirschen
R. Koim
T. Kuki
R. Kunkel
W. Lai
V. Lasker
N. Lau
B. Laughlin
F. Lim
T. Liu
J. Loo
K. Loughner
D. Loughry
T. Louhenkilibi
D. Manchester
M. Marco
D. Matters
D. McInode
D. Michels
L. Moraes
D. Morris
J. Murayama
R. Nelson
D. Olsevit

C. Ostereicher
M. Papa
S. Peter
D. Phuoc
T. Phinney
G. Power
A. Reddi
M. Repko
F. Restivo
L. Rich
D. Rine
R. Rosenthal
P. Ruosadri
S. Samoylenko
E. Sashi
A. Sauer
N. Schneidewind
O. Serlin
D. Shepard
D. Shoyer
H. Solomon
G. Stephens
C. Stillebroer
K. Sumner
E. Sykas
A. Tantawi
D. Tether
J. Tourret
K. Tu
D. Umbaugh
J. Vorhies
A. Weasberger
W. Wenker
T. Wicklund
T. Wolf
F. Wolff
R. Youg

The following persons were on the balloting committee that approved ANS/IEEE Std 802.3a-1988 (Section 10) for submission to the IEEE Standards Board:

Marshall Abrams	Keith W. Harbaugh	Marco Meli
John Adams	S. M. Harris	David S. Millman
William B. Adams	J. Scott Haugdahl	Aditya N. Mishra
S. R. Ahuja	Sharon Healy	Richard J. Moff
Kat Ashai	C. W. Hobbs	David R. Morgan
William Ayen	Jim P. Hong	Mike Morganli
Yong-Myung Bang	Paul L. Hutton	Kinji Mori
Wesley A. Ballenger, Jr.	Richard Ioff	D. J. Morris
Edwardo W. Bergamini	George D. Jelatis	H. T. Moustafah
Henk F. Beley	Guy Juanele	Dale A. Murray
Betty Brannick	Siegel L. Junker	Ruth Nelson
George S. Carson	Karl H. Kellermaier	J. Duane Northcott
Po Chen	Mladen Kezunovic	Charles Ostermicher
L. Y. Cheung	Samuel Kha	David Obsevitz
Kilnam Chon	David Kellin	Young Oh
T. Ricky Chow	Suzuki L. Kata	George Parewski
David Caban	Hirayr M. Kodyan	Thomas L. Phinney
Allen F. Conrad	Takahiko Kaki	Nikitas Pitsopoulos
Ira W. Cotton	Lee LaBarre	David Potter
Robert S. Crowder	Wai-Shun Lai	John Potvock
Michael Dias	Valerie Lasker	Gary S. Robinson
Mitchell G. Duncan	Lance M. Leach	Marys Bepko
Philip H. Enslow, Jr.	Edward Y. S. Lee	Robert Rosenthal
Judith Estrin	Stephan E. Levin	Gian Paolo Rossi
John W. Fendrich	P. C. Lim	David J. Rypko
Harvey A. Freeman	Don C. Loughry	S. I. Samoylenko
Patrick Gonda	Joseph K. P. Lubukay	Norman F. Schneiderwind
Ambuj Goyal	Wai-Shun Luk	Oscar Sepuivoda
Michael D. Graebner	Marco Marsan	Omer Serlin
Maria Graube	Joseph Massi	D. Shappard
Nobuhiko Hamada	Darrot B. Melndoe	R. M. Simmons
Joseph L. Hammond	Patrick S. McIntosh	David W. Slayter

When the IEEE Standards Board approved ANS/IEEE Std 802.3-1988 on June 9, 1988, and ANS/IEEE Std 802.3a-1988 (Section 10) on October 20, 1988, it had the following membership:

Donald C. Fleckenstein, Chair

Andrew G. Salem, Secretary

Marco Migliaro, Vice Chair

Arthur A. Blaisdell
Fletcher J. Buckley
James M. Daly
Stephen R. Dillon
Eugene P. Fogarty
Jay Forster*
Thomas L. Hannan
Kenneth D. Hendrix
Theodore W. Hinesy, Jr.

John W. Horch
Jack M. Kinn
Frank D. Kirchner
Frank C. Kitantides
Joseph L. Koepfinger*
Irving Kolodny
Edward Lahse
John E. May, Jr.
Lawrence V. McCall

L. Bruce McClung
Donald T. Michael*
Richard E. Masher
L. John Rankine
Gary S. Robinson
Frank L. Ross
Helen M. Wood
Karl H. Zaininger
Donald W. Zipse

*Member emeritus

ANS/IEEE Std 802.3-1988 and ANS/IEEE Std 802.3a-1988 were approved by the American National Standards Institute on January 12, 1989.

When the IEEE 802.3 Working Group approved ANSI/IEEE Std 802.3c-1985 (9.1-9.8) in July 1985, it had the following membership:

Donald C. Loughry, Chair
Geoffrey O. Thompson, Chair, Repeater Task Force

Menachem Abraham	Hacene Hariti	Aidan Paul
Keith Albright	Guy Harkins	David Potter
R. V. Balakrishnan	Fred Huang	Eric Rawson
William Belknap	Stephen Janshego	Joseph Rickert
Richard Bennett	Donald Johnson	Gary Robinson
Charles Brill	Kwi-Yung Jung	Timothy Rock
Juan Bulnes	Paul Kellam	David Roos
Stephen Cooper	Joe Kennedy	Robert Rosenthal
Paul Eastman	Hiroshi Kobayashi	Joseph St. Amand
Phil Edholm	Lee LaBarre	Walter Schreuer
Gregory Ennis	Tony Lauck	Semir Sirazi
Alan Flatman	John Laynor	David Smith
Richard Fransen	William Livingston	Stephen Soto
Ingrid Fromm	Terry Lockyer	Robert Summers
Robert Galin	James Lucas	Pat Thaler
Sharad Gandhi	Andy Luque	Wendell Turner
Rich Graham	Daniel Maltbie	Marc Warshaw
Richard Gumpertz	Steven Moustakas	Ronald Yara
	Lloyd Oliver	

The following persons were on the balloting committee that approved ANSI/IEEE Std 802.3c-1985 (9.1-9.8) for submission to the IEEE Standards Board:

Marshall Abrams	Richard Jiff	John Potvcek
John Adams	George D. Jelatis	Gary S. Robinson
William B. Adams	E.D. Jensen	Marya Repke
S. R. Ahuja	Guy Juangle	Robert Rosenthal
P. D. Amer	Karl H. Kellermayr	Gian Paolo Rossi
Kit Athul	Mladen Kozunovic	David J. Rypka
William Ayen	Samuel Kho	S. I. Samoylenko
Yong-Myung Baeg	David Kollm	Norman F. Schneidewind
Wesley A. Ballenger, Jr.	Sastri L. Kuta	Oscar Sepulveda
Edwardo W. Bergamini	Hiray M. Kudyan	Omri Serlin
H. F. Boley	Takahiko Kuki	D. Sheppard
Paul W. Campbell, Jr.	Lee LaBarre	R. M. Simmons
George S. Carson	Wai-Sum Lai	L. Sintonen
Po Chen	Lanse M. Leach	David W. Sloyer
L. Y. Cheung	Stephen E. Levin	Stephen Soto
Kilaam Chon	F. C. Lim	Fred Strauss
T. Ricky Chow	William Livingston	Bart W. Stuck
W. F. Chow	Don C. Loughry	Tatsuya Suda
David Cohen	Joseph F. P. Lohukay	Efstathios D. Sykas
Allen F. Conrad	Mehi Marco	Daniel T. W. Sze
Robert S. Crowder	Marco Marsan	Ahmed N. Tantaui
Michel Diaz	Joseph Massi	Mario Tokoro
Philip H. Enslow, Jr.	Darrell B. McIndoe	H. C. Torng
Judith Estrin	Patrick S. McIntosh	Donald F. Towsley
John W. Fendrich	David S. Millman	Wei-Tek Tsai
Harvey A. Freeman	Aditya N. Mishra	M. Tsuchiya
R. J. Gagliano	David E. Morgan	Richard Tung
Patrick Gonin	Mike Morganti	Stanko Turk
Ambuj Goyal	Kinji Mori	L. David Umbaugh
Michael D. Graebner	D. J. Morris	James Verhies
Maris Graube	H. T. Mouftah	Pearl S. C. Wang
Nobushiro Hamada	Dale A. Murray	Don Weir
Joseph L. Hammond	Ruth Nelson	Alan J. Weissberger
S. M. Harris	J. Duane Northcott	William J. Wenker
J. Scott Haugdahl	Charles Oestereicher	Earl J. Whitaker
C. W. Hobbs	Young Oh	Michael Willett
Jim P. Hong	George Parowski	Tsong-Ho Wu
Paul L. Hutton	Thomas L. Phinney	Oren Yuen
	David Potter	

When the IEEE Standards Board approved ANSI/IEEE Std 802.3c-1985 (9.1-9.8) on December 12, 1985, it had the following membership:

John E. May, Chair

Sava I. Sherr, Secretary

John P. Riganati, Vice Chair

James H. Beall
Walter J. Buckley
Rene Castenschild
Edward Chelotti
Edward J. Cohen
Paul G. Cummings
Donald C. Fleckenstein

Jay Forster
Daniel L. Goldberg
Kenneth D. Hendrix
Irvin N. Howell
Jack Kinn
Joseph L. Koepfinger*
Irving Koblitz
R. F. Lawrence

Lawrence V. McCall
Donald T. Michael*
Frank L. Rose
Clifford O. Swanson
J. Richard Weger
W. B. Wilbens
Charles J. Wyhe

*Member emerita

ANSI/IEEE Std 802.3c-1985 was approved by the American National Standards Institute on June 4, 1986.

When the IEEE 802.3 Working Group approved ANSI/IEEE Std 802.3d-1987 (9.9), it had the following membership:

Donald C. Loughry, Chair
Steven Moustakas, Chair, Task Force

Menschel Abraham
Keith Alknight
Keith Amundson
Jean-Pierre Astorg
R. V. Balakrishnan
Richard Bennett
Charles Beil
Juan Buñes
Robert Campbell
Luigi Canavese
Albert Chasson
Peter Dawe
Peter Desautiers
Raymond Dubey
Jeff Ebling
Gianfranco Enrico
Alan Flatman
Richard Franzon
Ingrid Fromm
Robert Gall
Mark Gerhold
Adi Gilbert
Rich Graham
Rich Gumperts
Hacene Hariti

Lloyd Hasley
Hawming Huang
Charles Hoffner
Michael Hughes
Donald Johnson
Mae Johnson
Kwi-Yung Jung
Matt Kaltenbach
Paul Kellam
Scott Kester
Hiroshi Kobayashi
Hideakazu Kurakawa
Lee LaBarre
Ed Lare
Wayne Lindquist
Terry Lockyer
Don Loughry
James Lucas
Andy Lucas
Lloyd Oliver
Alden Paul
Roy Pierce
Eric Rawson
Joseph Rickert
Gary Robinson

Timothy Rock
David Koss
Walter Schruer
Sesir Shazi
David Smith
Robert Summers
Pat Thaler
Geoff Thompson
Nathan Tobol
Czeslaw Tomaszewski
Wendell Turner
Joseph Wiencko
Bruce Williams

OBSERVERS

Allen Charin
John Deerman
Paul Eastman
Shinji Emori
Jiro Kashio
Michael Lee
Luciano Marchitto
Jim Mastrose
Peter Tarrant

The IEC TC83 Committee on Information Technology Equipment also provided very helpful input to the development of the FOIRL Standard (9.9).

The following persons were on the balloting committee that approved ANSI/IEEE Std 802.3d-1987 (9.9) for submission to the IEEE Standards Board:

William B. Adams	M. Kezunovic	Gary S. Robinson
S. R. Ahuja	Samuel Kno	Robert Rosenthal
Kit Athul	S. E. Kille	Gian Paolo Rossi
William Ayen	David Kefim	David J. Rypka
Eduardo W. Bergamini	Takahiko Kuki	S. I. Samaylenko
Paul W. Cornphell, Jr.	Lee LaBarre	Norman F. Schneidewind
George S. Carson	Wai-Sum Lai	Omri Serlin
Pe Chen	Lance M. Leach	D. Shappard
L. Y. Cheung	Edward Y. Lee	Ron Simmons
Kilnam Chon	R. C. Lightburn	J. B. Sinclair
W. F. Chow	P. C. Lim	L. Sintonen
Michael Coden	William D. Livingstoa	Tom Stack
A. F. Conrad	Don C. Loughry	Carel M. Stillebroer
Robert S. Crowder	Joseph F. P. Luhukay	Fred Strauss
Michel Diaz	Wo-Shun Luk	Tatsuya Suda
N. I. Dimopoulos	Marco Ajmone Marsan	P. Sugar
M. G. Duncan	Joseph Massi	Efstathios D. Sykas
Philip H. Enslow, Jr.	Marco Meh	Daniel T. W. Sze
Judith Estrin	Darrel B. McIndoe	Ahmed N. Tantawi
John W. Ferndrich	P. S. McIntosh	H. C. Torng
Harvey A. Freeman	David S. Millman	D. F. Towsley
Patrick S. Gonia	Aditya N. Mishra	Wei-Tek Tsai
R. L. Gordon	David E. Morgan	Stanko Turk
A. Goyal	Mike Morganti	L. David Unbaugh
M. D. Grashner	Kanji Mori	J. T. Verhees
Maris Graube	David Morris	Pearl S. C. Wang
Joseph L. Hammond	H. H. T. Moutah	Den Weir
Stephen Harris	Dale N. Murray	Alan J. Weissburger
J. Scott Haugdahl	R. R. Nelson	W. J. Wenker
C. W. Hobbs	J. D. Northeut	Earl J. Whitaker
Paul Hutton	Charles Oesterreicher	Bryan Whittle
Richard Illif	Young Oh	Michael Willett
E. D. Jenson	George Parowski	David C. Wood
Guy Juannole	Thomas L. Phinney	Tsong-Hu Wu
Karl H. Kollermayr	J. M. Potucek	Oren Yuen
	Marya Repko	

When the IEEE Standards Board approved ANSI/IEEE Std 802.3d-1987 (9.9) on December 12, 1985, it had the following membership:

Donald C. Fleckenstein, Chair

Andrew G. Salem, Secretary

Marco Migliaro, Vice Chair

James H. Beall
Dennis Bodson
Marshall L. Cain
James M. Daly
Stephen R. Dillon
Eugene P. Fogarty
Jay Forster
Kenneth D. Hendrix
Irvin N. Howell

Leslie R. Kerr
Jack Kinn
Irving Kolodny
Joseph L. Kospfinger*
Edward Lohse
John May
Lawrence V. McCall
L. Bruce McClung

Donald T. Michael*
L. John Rankine
John P. Riganati
Gary S. Robinson
Frank L. Rose
Robert E. Rountree
William R. Tackaberry
William B. Wilkens
Helen M. Wood

*Member emeritus

ANSI/IEEE Std 802.3d-1987 was approved by the American National Standards Institute on February 9, 1989.

When the IERE 802.3 Working Group approved ANSI/IEEE Std 802.3b-1985 (Section 1.1), it had the following membership:

Donald C. Loughry, Chair
Menachem Abraham, Chair, Type 10BROAD36 Task Force

Keith Abright
E. V. Balakrishnan
William Bekamp
Richard Bennett
Charles Brill
Juan Bulnes
Stephen Cooper
Renald Crane
John Davishen
Mark Devan
Paul Eastman
Phil Edholm
Gregory Ennis
Judy Estrin
Alan Fiatman
Richard Fryer
Ingrid Fussner
Robert Galin
Shazad Ganshi
Rick Graham
Richard Gumpertz
Hassan Harati
Guy Harkins
Gregory Hopkins

Fred Huang
Stephen Janabege
Donald Johnson
Kwi-Yung Jung
Paul Kellam
Joe Kennedy
Hiroschi Kobayashi
Lee LaBarre
Ed Lam
Tony Lauck
John Laynor
William Livingston
Terry Lockyer
Hugh Logan
Leland Long
James Loner
Andy Lague
Dennis Mathis
Joseph Mauer
Steven Mountakis
Narayan Murthy
Wendell Niskanen
Lloyd Oliver

Aidan Paul
David Potter
Eric Rawson
Eugene Reilly
Joseph Rickert
Anthony Rizzo
Gary Robinson
Timothy Rock
David Ross
Robert Rosenthal
Joseph St. Amant
Walter Schreier
Semir Sircsi
David Smith
Stephen Soto
Gary Spencer
Robert Summers
Pat Tucker
Geoff Thompson
Nathan Tubol
Wendell Turner
Marc Warshaw
David White
Mo Zouana

The following persons were on the balloting committee that approved ANSI/IEEE Std 802.3b-1985 (Section 1.1) for submission to the IEEE Standards Board:

Marshall Abrams
John Adams
William B. Adams
S. R. Ahuja
Eli Achi
William Ayen
Yong-Myung Bang
Wesley A. Balkinger, Jr.
Edwardo W. Bergasini
Henk F. Beley
George S. Carson
Fu Chan
L. Y. Cheung
Kilnam Chon
T. Ricky Chow
David Cohen
Alan F. Conrad
Ira W. Corten
Robert S. Crowder
Michael Diaz
Mitchell G. Duncan
Philip H. Enaker, Jr.
Judith Estrin
John W. Fendrich
Harvey A. Freeman
Patrick Genia
Ashraf Goyal
Michael D. Grachner
Marcia Grache
Nobuhim Hamada
Joseph L. Hammond
Keith W. Hartough
S. M. Harris
J. Scott Haugdahl
Sharon Hasly
C. W. Hobbs
Jim P. Hong
Paul L. Hutton
Richard III
George D. Jolatus

E. Douglas Jensen
Guy Juzevic
Siegel L. Junker
Karl H. Kellermayer
Mudassir Khanmohr
Samuel Khe
David Kellin
Sastri L. Kota
Hirayr M. Kudyan
Takafiko Kuki
Lee LaBarre
Wai-Sum Lai
Valerie Lasker
James M. Laska
Edward Y. S. Lee
Stephen E. Levin
F. C. Lim
Donald C. Loughry
Joseph P. P. Lohakay
Wu-Shun Luk
Marco Maman
Joseph Mami
Darrell B. McIndoe
Patrick S. McIntosh
Marco Mell
David S. Millman
Aditya N. Mishra
Richard J. Moff
David K. Morgan
Mike Morganti
Kings Mori
D. J. Morris
H. F. Moudiah
Dale A. Murray
Ruth Nelson
J. Duane Northcott
Charles Gustavovich
David Ofsevit
Young Oh

George Parowski
Thomas L. Phinney
Nikolas Pissopoulos
David Potter
John Potvock
Gary S. Robinson
Marya Rypka
Robert Rosenthal
Glen Paolo Ross
David J. Rypka
S. I. Samoylenko
Norman P. Schaidewind
Oscar Sepulveda
Omri Berlin
D. Sheppard
R. M. Sizemans
David W. Sloyer
Stephen Soto
Tom Stack
Carol M. Stillkruser
Fred Strauss
Burt W. Stack
Tatsuya Suda
Peter Sugar
Efthathios D. Sykas
Daniel T. W. See
Ahmed N. Tantaoui
Mario Tokoro
H. C. Tseng
Donald F. Trowley
Wei-Tak Tsui
M. Tsuchiya
Richard Tung
Stanko Turk
L. David Umbaugh
James Vorhies
Pavel S. C. Wang
Don Weir
Alan J. Weisberger
William J. Wenker

Ravi J. Whitaker
Bryan S. Whittle

Michael Willett
Donald Wittman

George E. Wood
Tsung-Ho Wu

When the IEEE Standards Board approved ANSI/IEEE Std 802.3b-1985 (Section 11) on September 19, 1985, it had the following membership:

John E. May, Chair

Sava L. Sherr, Secretary

John P. Riganati, Vice Chair

James H. Beall
Fletcher J. Buckley
Beno Castenschild
Edward Chejeth
Edward J. Cohen
Paul G. Cummings
Donald C. Fleckenstein

Jay Forster
Daniel L. Goldberg
Kenneth D. Hendrix
Irvin N. Howell
Jack Kinn
Joseph L. Koepfinger*
Irving Klotzky
R. F. Lawrence

Lawrence V. McCall
Donald T. Michael*
Frank L. Rose
Clifford G. Swanson
J. Richard Weger
W. B. Wilkens
Charles J. Wylie

*Member emeritus

ANSI/IEEE Std 802.3b-1985 was approved by the American National Standards Institute on February 28, 1986.

When the IEEE 802.3 Working Group approved ANSI/IEEE Std 802.3e-1987 (Section 12) in November 1986, it had the following membership:

Donald C. Loughry, Chair

Robert Galin, Chair, Type 1BASE5 Task Force

Menachem Abraham
Keith Albright
Keith Amundson
Jean-Pierre Astorg
R. V. Balakrishnan
Ian Barker
Charles Brill
Juan Bolnes
Robert Campbell
Luigi Canavese
Albert Claassen
Michael Cohen
Bill Cronin
Peter Daws
Peter Dessaulniers
Raymond Duley
Jeff Ebeling
Gianfranco Enrico
Alan Flatman
Richard Franzen
Mark Gerhold
Adi Gilbert

Rich Graham
Richard Gumperts
Haceme Hariti
Lloyd Hasley
How Ming Huang
Charles Hoffman
Michael Hughes
Donald Johnson
Miss Johnson
Kwi-Yung Jung
Matt Kaltenbach
Paul Kalhan
Scott Kester
Hirosaki Kobayashi
Hidetomo Kurokawa
Michael Lee
Lee LaBarre
Terry Lockyer
James Lucas
Andy Luque
Luciano Marchitto
Steven Moustakas

Lloyd Oliver
Roy Plores
Bill Poston
Eric Rawson
Joseph Rickert
Gary Robinson
Timothy Rock
David Rose
Eli Sakaguchi
Walter Schreiner
Semir Sircaci
David Smith
Robert Summers
Peter Tarrant
Mark Taylor
Pat Thaler
Geoff Thompson
Nathan Tobel
Carlos Tomaszewski
Jayshree Ullal
Joseph Wisniewski
Bruce Williams

The following persons were on the balloting committee that approved ANSI/IEEE Std 802.3e-1987 (Section 12) for submission to the IEEE Standards Board:

Marshall D. Abrams	Richard Bluff	J. M. Potocak
William B. Adams	E. D. Jensen	Marya Replek
S. R. Ahuja	Guy Juazele	Gary S. Robinson
P. D. Amer	S. L. Junkas	Robert Rosenthal
Kit Athul	Karl H. Kellermayr	Gian Paolo Rossi
William Ayen	M. Kezunovic	David J. Rypka
Edoardo W. Bergamini	Samuel Klu	S. I. Samsylenko
H. F. Boley	S. E. Kille	Norman F. Schneidewind
Paul W. Campbell, Jr.	David Kollm	Omri Sorlin
George S. Carason	Takahiko Kuki	D. Sheppard
Pu Chen	Lee LaBarre	Ben Simmons
L. Y. Cheung	Wai-Sum Lai	J. B. Sinclair
Kilnam Chun	Lance M. Leach	L. Sintouan
W. F. Chew	Edward Y. Lee	Stephen H. Soto
Michael Codan	S. E. Levin	Tom Stack
A. F. Conrad	R. C. Lighthorn	Carel M. Stillebror
Ira Cotton	F. C. Lim	Fred Strauss
D. E. Crotty	William D. Livingston	Bart W. Stuck
Robert S. Crowder	Don C. Loughry	Tafanya Suda
Michel Diaz	Joseph P. P. Luhnaky	P. Sugar
N. I. Dimopoulos	Wo-Shun Luk	Efremthios D. Sykas
M. G. Dussan	Marco Ajmons Marasa	Daniel T. W. Sze
P. M. Elliot	Joseph Massi	Ahmed N. Tactawi
Phillip H. Enslow, Jr.	Marco Melli	H. O. Terug
Judith Estrin	Darrel B. McIndoe	D. F. Towsley
John W. Fendrich	P. S. Melotash	Wei-Tek Tsai
G. A. Foggiate	David S. Millman	Masahiro Tsuchiya
Harvey A. Freeman	Aditya N. Mishra	Stanley Turk
Robert J. Gagliano	David E. Morgan	L. David Umbaugh
T. F. Gannon III	Mike Morganti	J. T. Vorties
Patrick S. Gonia	Kanji Mori	Peuri S. C. Wang
R. L. Gordon	David Morris	Don Weir
A. Goyal	H. H. T. Mooltah	Alan J. Weissburger
M. D. Grashnar	Dahn N. Murray	W. J. Wenker
Maris Graube	R. R. Nelson	Earl J. Whitaker
Joseph L. Hammond	J. D. Northcut	Bryan Whittle
Stephen Harris	Charles Oesterreicher	Michael Willatt
J. Scott Haugdahl	Yeung Oh	David C. Wood
C. W. Hobbe	George Parowski	Tsang-Hu Wu
Paul Hutson	Thomas L. Phinney	Gen Yuan
	David Potter	

When the IEEE Standards Board approved ANSI/IEEE Std 802.3e-1987 (Section 12) on June 11, 1987, it had the following membership:

Donald C. Flockenstein, *Chair*

Marco W. Migliaro, *Vice Chair*

Andrew G. Salem, *Secretary*

James H. Beall	Leslie R. Karr	L. John Rankine
Dennis Bodson	Jack Kinn	John P. Rigault
Marshall L. Cain	Irving Kolesny	Gary S. Robinson
James M. Daly	Joseph L. Koepfinger*	Frank L. Rose
Stephen R. Dillon	Edward Lotise	Robert E. Rountree
Eugene P. Fogarty	John May	Sava I. Sharr*
Jay Forster	Lawrence V. McCall	William K. Tackabory
Konnet D. Hendrix	L. Bruce McClung	William B. Wilkens
Irvin N. Howell	Donald T. Michael*	Helen M. Wood

*Member emeritus

ANSI/IEEE Std 802.3e-1987 was approved by the American National Standards Institute on December 15, 1987.

When the IEEE 802.3 Working Group approved ANSI/IEEE Std 802.3h-1990 (Section 5), it had the following membership:

Donald C. Loughry, Chair
Andy J. Luque, Chair, Layer Management Task Force

Menachem Abraham	W. B. Hatfield	Keith Onodera
John R. Ages	Stephen Haughey	Tony Peatfield
Richard Anderson	Carl G. Hayssen	Peter Rautenberg
Ekkehard Antz	Ariel Hendel	Bill Reysen
Keith Amundsen	Chip Hicks	Gary Robinson
Susie Armstrong	William Hingston	Steven Robinson
R. V. Balakrishnan	Charles Hoffner	Moni Samaan
Mark Bohrer	Ernie Jensen	Fred Sammartino
Richard Brand	Clarence Joh	Stan Sassower
Thomas Butler	Dieter W. Junkers	F. Sarles
Lusa Caffero	Donald C. Johnson	Ronald Schmidt
Robert R. Campbell	Mize Johnson	Tom Schmitt
Luigi Canavese	Scott Kessler	Frederick Scholl
Jacques Christ	Bob Kilgore	Ron Shani
Michael Coden	Yongbum Kim	Semir Sirazi
Robert Conte	Bill Kind	Joseph Skorupa
Bill Cronin	John Kincaid	David A. Smith
Peter Cross	Tadayoshi Kitayama	Bob Smith
John DeCramer	Paul Kopera	Steve Smith
Ian Crayford	David Kung	Robert Snyder
Nabil Dameouny	Michael Lee	Graham Starkins
Sanjay Dhawan	Richard Lena	David E. Stein
Raymond S. Duley	Yoseph Linde	Peter Tarrant
Paul Eastman	Wayne Lindquist	Mark Taylor
Richard Ely	T. D. Lockyer	Patricia Thaler
Gianfranco Enrico	James A. Lucas	Douglas Thompson
Norman Erbacher	Ian Lyoo	Geoffrey O. Thompson
Steve Evtis	Kenneth MacLeod	Naihan Tobol
Alan V. Flatman	Luciano Marchitto	Carlos Tomaszewski
Ingrid Fromm	Charles Marsh	Herbert Uhl
Mel Gabler	Bob Matthys	Steven Ulrich
Bob Galin	Steven Moustakas	John Visser
Mark Gerhold	Narayan Murthy	William Wager
Rich Graham	Darcy Nelson	Joseph A. Wiencko, Jr.
Andreas Gulle	Bob Norton	Bruce Williams
Richard Gumpertz	Mike O'Connor	Richard Williams
Clive Hallatt	Chris Oliver	Roger Wilmarth
Kevin Hamilton	Lloyd Oliver	Mike Wincen
Benny Hanigal	Kazuyuki Ozawa	Mark Wingrove
Lloyd Hasley		Nobushige Yokota

The following persons were on the balloting committee that approved ANSI/IEEE Std 802.3h-1990 for submission to the IEEE Standards Board:

William Adams	Maris Graube	Darrell B. McIndoe
Kit Athul	Joseph L. Hammond	Richard H. Miller
William E. Ayen	Stephen Harris	David S. Millman
Ali Bahrololoomi	J. Scott Haugdahl	Aditya Mishra
George S. Carson	C.W.L. Hobbs	John E. Montague
Chih-Tsai M. Chen	Chris Hsieh	M. A. F. Morganti
Michael H. Ceden	Richard J. Duff	Kinji Mori
R. A. Conser	Raj Jain	D. J. Morris
R. S. Crowder	M. Kazunovic	M. T. Mouftah
Andrew Davidson	Samuel Kho	Acne A. Nilsson
Luis F. M. De Moraes	Tom Kurihara	Charles Oestereicher
N. I. Dimopoulos	Lee Labarre	Young Oh
Mitchell Duncan	Anthony B. Lake	Thomas L. Phinney
John E. Emrich	Mike Lawler	Rafat Pirzada
John W. Fendrich	Jaiyong Lee	Udo Pooch
Harold C. Foite	F. C. Lim	Robert S. Printis
Harvey Freeman	Randolph S. Little	Marya S. Repko
Ingrid Fromm	William Livingston	John P. Riganati
D. G. Gan	Joseph Leo	Gary S. Robinson
Patrick Gonja	Donald C. Loughry	N. F. Schneidewind
Julio Gonzalez Sanz	Andy J. Luque	Manfred H. Seufert
Michael Graebner	Kelly C. McDonald	D. A. Sheppard

Glen Sherwood
R. M. Sorenson
Leo Srinivasan
Harry P. Solomon
Robert K. Southard
John Spragins
C. M. Stillebrever

Frank J. Strauss
E. D. Sykes
A. N. Tostawi
Nathan Tsoot
Tori-Tek Tsui
David L. Umbrough
T. A. Varotani

James Verhees
Don Weir
A. F. Wheeler
Karl J. Whitaker
D. C. Wood
George B. Wright
Orin Yuan

When the IEEE Standards Board approved ANSI/IEEE Std 802.3h-1990 on September 28, 1990, it had the following membership:

Marco W. Migliaro, *Chairman*

James M. Daly, *Vice Chairman*

Andrew G. Salem, *Secretary*

Donnie Hodson
Paul F. Herrill
Fletcher J. Hockley
Allen L. Clapp
Stephan R. Dillon
Donald C. Fleckenstein
Jay Foster*
Thomas L. Haman

Kenneth D. Hendrix
John W. Herrick
Joseph L. Koepfinger*
Irving Kolodny
Michael A. Lawler
Donald J. Loughry
John R. May, Jr.

Lawrence V. McCall
L. Bruce McChung
Donald T. Michael*
Sig Nilsson
Ray T. Oishi
Gary S. Robinson
Terrance K. Walthers
Donald W. Zipes

*Member Emeritus

ANSI/IEEE Std 802.3h-1990 was approved by the American National Standards Institute on March 11, 1991.

When the IEEE 802.3 Working Group approved ANSI/IEEE Std 802.3i-1990 (Sections 13 and 14), it had the following membership:

Donald C. Loughry, *Chair**

Patricia Thaler, *Chair, Type 10BASE-T Task Force†*

Menashe Abraham
Luc Adriaenssens
John R. Agre
Keith Amundson
Richard Anderson
Stephen J. Anderson
Ekkehard Antz
Susie Armstrong
R. V. Balakrishnan
Roberto Bertoldi
Deva Bishnis
Mark Bohrer
Richard Brand
Thomas Butler
Luca Caffero
Robert R. Campbell
Luigi Canavese
Michael Cohen
Kevin Coon
Robert Comte
Neil Coote
Ian Crawford
Bill Cronin
Peter Cross
Joe Curcio
Nabil Damany
Mark Darty
John DeCromet
Tazio M. Denicola
Sanjay Dewan

Paul (Skip) Fly
Richard Fly
Norman Etkacher
Steve Evitts
Eldon Feist
Alan V. Flatman
Ingrid Fromm
Mel Gable
Robert Gwin
Mark Gerhold
Andrew Gulle
Richard Gunpert
Clive Hallatt
Bevvy Hanigal
W. R. Hatfield
Stephen Hawghey
Carl G. Hayssen
Ernie Jensen
Clarence Job
Donald C. Johnson
Miss Johnson
Imre Juhász
Dieter W. Juckum
Joni S. Kalman
Rainer Kage
Bob Kilgore
Yonghwan Kim
John Kissaid
Bill Klod
Tadayoshi Kitayama

Steven Koller
Paul Kopera
Lennel Kosherov
Ted Kuznetz
David Kung
Michael Lehar
Michael Lee
Richard Lefkowitz
Richard Lena
Yuseph Linde
T. D. Lockyer
Andy J. Luque
Kenneth MacLeod
Luciano Marchitto
Charis March
Steven Moustakas
Narayan Murthy
Darryl Nilson
Bob Norton
Mike O'Connor
Chris Oliver
Lloyd Oliver
Keith Osadera
Kazuyuki Osawa
Charles Palumbo
Tony Pustfield
Peter Rautenberg
Bill Reppen
Gary Robinson
Steven Robinson

*Patricia Thaler, *Current Chair*

†Richard Anderson, *Current Chair*

Paul F. Russo
Mend Samann
P. Surlas
Stan Sussower
Ronald Schmidt
Tom Schmitt
Frederick Scholl
Ron Shani
Joseph Skorupa
David A. Smith

Bob Smith
Steve Smith
Robert Snyder
Graham Starkins
David E. Stein
Peter Tarrant
Mark Taylor
Douglas Thompson
Geoffrey Thompson
Nathan Tobal

Carlos Trzaskowski
Hansbert Uhl
John Vioer
William Wagner
Joseph Wisnicks, Jr.
Richard Williams
Roger Wilmarth
Mike Wisn
Mark Wingreen
Nobushige Yokota

The following persons were on the balloting committee for ANSI/IEEE Std 802.3i-1990:

Bandula W. Abeyandara
William B. Adams
Den Ashmore
Hanan S. Alkhatib
Jonathan Allan
Sule Arslander
KR Athul
Michael Atkinson
William E. Ayas
Yang Myung Baeg
Subhash Bhatia
Aas O. Bishop
Alan L. Bridges
Richard Cassi
Mehmet H. Caglayan
Anthony L. Carrata
George S. Carson
Brian J. Casey
George C. Chachis
Chih-Tsai Chen
Gerold W. Cichanowski
Michael H. Coden
Keith Collins
Rodney A. Connor
Robert Crowder
Jesse A. Cusato
F. Deravi
Ashwani K. Dharwan
Soyi Terry Deng
Mitchell G. Duncan
Andrew M. Dunn
Sourav Duttin
Ted Dzik
Hans Eklund
John E. Emrich
Richard G. Estock
Changxin Fan
John W. Fendrich
John N. Ferguson
Samuel Fineberg
Ernest L. Fogle
Harold C. Fotts
Sandra J. Forney
Harvey A. Frossman
Ingrid Fromm
Elhan Fromstein
Robert Gagliano
Issac Ghannah
Patrick Genix
Michael D. Gruebner
Maxis Graube
Abraham Grund
Craig Guarnieri
Sander V. Habas
Joseph L. Hammond
Clark M. Hay
Lee A. Hollaar
Marsha D. Hopwood
Anne B. Horton
Gemsie L. Hubacher
Wing Huan

Bob Jacobson
Raj Jain
Gerrit K. Janaman
Jack K. Johnson
Rajjo Jovanovic
Richard H. Karpinski
Julian Katsely
Gary C. Kessler
Samuel Koo
Jens Kalland
Vijaya Katarangi
Peter Kernerup
Jon Krump
Stephen B. Kruger
Thomas M. Kurthorn
Anthony B. Lake
Lok Ming Lam
Glen Langdon
Mike Lawler
Lance M. Leach
John E. Lecky
Jai-Yang Lee
Michael E. Lee
Lewis E. Leinenweber
Kin Fux Lo
F. C. Lim
Ping Liu
Randolph B. Little
William D. Livingston
Mauris Luth
Wayne M. Loucks
Donald Loughrey
Norm C. Low
Andy J. Lopez
Carel R. Maassen
Eduardo G. Marmol
Gerald M. Mason
Richard McBeide
Kelly C. McDonald
William McDonald
Darrell B. McIndoe
Richard H. Miller
David S. Millman
C. S. M. Mishra
Wen Hsien Lim Moh
John E. Montague
Kingsi Mori
Gerald Moseley
H. H. T. Moustah
K. R. S. Murthy
Charles E. Neblock
Ruth Nelson
Arne A. Nilsson
Donal O'Mahony
Frederic Oakland
Charles Oustarsicher
Attila Osgit
Richard J. Purnilion
Thomas R. Phillips
Art J. Pinn
Radat Pirzada
Odo W. Pusch

Hardy J. Pottinger
Andris Potnina
Thad L. D. Ragulinski
Francesca J. Reffivo
John K. Rignanti
Saber Risk
Philip T. Robinson
Gary S. Robinson
Robert Rosenthal
David Rosich
Floyd R. Ross
Victor Rosentouler
Chizuki Sagawa
Mark S. Sanders
Bavi Sankar
Julio Gonzalez Sant
Ambatipudi Sastry
Vidyadhar S. Savant
Manoj Kumar Saxena
Lorne Schachter
Norman Schneiderwind
Jeffrey K. Schwab
A. D. Sheppard
Glen Sherwood
William T. Smith
I. A. Sorenson
Robert K. Spothard
Charles Spurgens
Michael Stephenson
Fred J. Strauss
Efstathios D. Sykas
Ray S. Syler
Gregory M. Sylvain
David See
Nhi P. Ts
Hassan Tabain
Hao Tang
Ahmed N. Tautawi
Steven R. Taylor
James N. Thomas
Geoffrey O. Thompson
Nathan Tobal
Robert Tripi
L. David Umbough
Thomas A. Varotoni
James T. Verhies
Harry Verbruck
Clarence M. Wouwer
Donald F. Weir
Alan J. Weisberger
Raymond Wenig
William J. Wenker
Earl J. Whitaker
Thomas F. Wiggan
Michael Willst
Paul A. Willis
George B. Wright
Jen-Kun Yang
Oren Yuan
William H. Yundt
Zhuo Wei

When the IEEE Standards Board approved ANSI/IEEE Std 802.3i-1990 on September 28, 1990, it had the following membership:

Marco W. Migliaro, Chairman

James M. Daly, Vice Chairman

Andrew G. Salem, Secretary

Dennis Beeson
Paul L. Borrill
Fletcher J. Buckley
Allen L. Clapp
Stephen R. Dillon
Donald C. Fleckenstein
Jay Forster*
Thomas L. Hansen

Kenneth D. Hendrix
John W. Horch
Joseph L. Koepfinger*
Irving Kolodny
Michael A. Lawler
Donald J. Loughry
John E. May, Jr.

Lawrence V. McCall
L. Bruce McChung
Donald T. Michael*
Stig Nilsson
Ray T. Osh
Gary S. Robinson
Terrence R. Whittemore
Donald W. Zipse

*Member Emeritus

ANSI/IEEE Std 802.3i-1990 was approved by the American National Standards Institute on March 11, 1991.



6

4

.....

4

.....

.....

Contents

SECTION	PAGE
1. Introduction	31
1.1 Overview	31
1.1.1 Basic Concepts	31
1.1.2 Architectural Perspectives	31
1.1.3 Layer Interfaces	33
1.1.4 Application Areas	33
1.2 Notation	33
1.2.1 State Diagram Conventions	33
1.2.2 Service Specification Method and Notation	34
1.2.3 Physical Layer and Media Notation	35
1.2.4 Physical Layer Message Notation	35
1.3 References	35
1.4 Definitions	36
2. MAC Service Specification	37
2.1 Scope and Field of Application	37
2.2 Overview of the Service	37
2.2.1 General Description of Services Provided by the Layer	37
2.2.2 Model Used for the Service Specification	37
2.2.3 Overview of Interactions	37
2.2.4 Basic Services and Options	37
2.3 Detailed Service Specification	38
2.3.1 MA_DATA.request	38
2.3.2 MA_DATA.indication	38
3. Media Access Control Frame Structure	41
3.1 Overview	41
3.1.1 MAC Frame Format	41
3.2 Elements of the MAC Frame	41
3.2.1 Preamble Field	41
3.2.2 Start Frame Delimiter (SFD) Field	42
3.2.3 Address Fields	42
3.2.4 Destination Address Field	43
3.2.5 Source Address Field	43
3.2.6 Length Field	43
3.2.7 Data and PAD Fields	43
3.2.8 Frame Check Sequence Field	43
3.3 Order of Bit Transmission	44
3.4 Invalid MAC Frame	44
4. Media Access Control	45
4.1 Functional Model of the Media Access Control Method	45
4.1.1 Overview	45
4.1.2 CSMA/CD Operation	46
4.1.3 Relationships to LLC Sublayer and Physical Layer	47
4.1.4 CSMA/CD Access Method Functional Capabilities	47
4.2 CSMA/CD Media Access Control Method (MAC): Precise Specification	48
4.2.1 Introduction	48
4.2.2 Overview of the Procedural Model	48
4.2.3 Frame Transmission Model	54
4.2.4 Frame Reception Model	55
4.2.5 Preamble Generation	56
4.2.6 Start Frame Sequence	57
4.2.7 Global Declarations	57
4.2.8 Frame Transmission	59
4.2.9 Frame Reception	63
4.2.10 Common Procedures	65
4.3 Interfaces to/from Adjacent Layers	66

SECTION	PAGE	
4.3.1	Overview	66
4.3.2	Services Provided by the MAC Sublayer.....	66
4.3.3	Services Required from the Physical Layer.....	67
4.4	Specific Implementations	68
4.4.1	Compatibility Overview	68
4.4.2	Allowable Implementations	69
5.	Layer Management	71
5.1	Introduction.....	71
5.1.1	Systems Management Overview	71
5.1.2	Layer Management Model	72
5.2	Management Facilities	73
5.2.1	Introduction	73
5.2.2	MAC Sublayer Management Facilities	73
5.2.3	Physical Layer Management Facilities.....	77
5.2.4	Layer Management Model	77
6.	PLS Service Specifications.....	83
6.1	Scope and Field of Application	83
6.2	Overview of the Service	83
6.2.1	General Description of Services Provided by the Layer.....	83
6.2.2	Model Used for the Service Specification	83
6.2.3	Overview of Interactions	83
6.2.4	Basic Services and Options	84
6.3	Detailed Service Specification	84
6.3.1	Peer-to-Peer Service Primitives.....	84
6.3.2	Sublayer-to-Sublayer Service Primitives	86
7.	Physical Signaling (PLS) and Attachment Unit Interface (AUI) Specifications	87
7.1	Scope.....	87
7.1.1	Definitions	87
7.1.2	Summary of Major Concepts.....	88
7.1.3	Application.....	88
7.1.4	Modes of Operation	88
7.1.5	Allocation of Function	88
7.2	Functional Specification	88
7.2.1	PLS-PMA (DTE-MAU) Interface Protocol.....	89
7.2.2	PLS Interface to MAC and Management Entities.....	94
7.2.3	Frame Structure	95
7.2.4	PLS Functions	96
7.3	Signal Characteristics.....	98
7.3.1	Signal Encoding	98
7.3.2	Signaling Rate	102
7.3.3	Signaling Levels	102
7.4	Electrical Characteristics	103
7.4.1	Driver Characteristics.....	103
7.4.2	Receiver Characteristics	104
7.4.3	AUI Cable Characteristics	108
7.5	Functional Description of Interchange Circuits.....	108
7.5.1	General.....	108
7.5.2	Definition of Interchange Circuits.....	109
7.6	Mechanical Characteristics	111
7.6.1	Definition of Mechanical Interface	111
7.6.2	Line Interface Connector	111
7.6.3	Contact Assignments	113
8.	Medium Attachment Unit and Baseband Medium Specifications, Type 10BASE5	115
8.1	Scope.....	115
8.1.1	Overview	115
8.1.2	Definitions	116

SECTION	PAGE	
8.1.3	Application Perspective: MAU and MEDIUM Objectives.....	116
8.2	MAU Functional Specifications.....	117
8.2.1	MAU Physical Layer Functions.....	118
8.2.2	MAU Interface Messages.....	120
8.2.3	MAU State Diagrams.....	121
8.3	MAU-Medium Electrical Characteristics.....	121
8.3.1	MAU-to-Coaxial Cable Interface.....	121
8.3.2	MAU Electrical Characteristics.....	125
8.3.3	MAU-DTE Electrical Characteristics.....	126
8.3.4	MAU-DTE Mechanical Connection.....	126
8.4	Characteristics of the Coaxial Cable.....	126
8.4.1	Coaxial Cable Electrical Parameters.....	126
8.4.2	Coaxial Cable Properties.....	127
8.4.3	Total Segment DC Loop Resistance.....	128
8.5	Coaxial Trunk Cable Connectors.....	128
8.5.1	Inline Coaxial Extension Connector.....	129
8.5.2	Coaxial Cable Terminator.....	129
8.5.3	MAU-to-Coaxial Cable Connector.....	129
8.6	System Considerations.....	130
8.6.1	Transmission System Model.....	130
8.6.2	Transmission System Requirements.....	131
8.6.3	Labeling.....	134
8.7	Environmental Specifications.....	134
8.7.1	General Safety Requirements.....	134
8.7.2	Network Safety Requirements.....	134
8.7.3	Electromagnetic Environment.....	135
8.7.4	Temperature and Humidity.....	136
8.7.5	Regulatory Requirements.....	136
9.	Repeater Unit for 10 Mb/s Baseband Networks.....	137
9.1	Overview.....	137
9.2	Definitions.....	137
9.3	References.....	138
9.4	Compatibility Interface.....	138
9.4.1	AUI Compatibility.....	139
9.4.2	Direct Cable Compatibility.....	139
9.4.3	Link Segment Compatibility.....	139
9.5	Basic Functions.....	139
9.5.1	Repeater Set Network Properties.....	139
9.5.2	Signal Amplification.....	140
9.5.3	Signal Symmetry.....	140
9.5.4	Signal Retiming.....	140
9.5.5	Data Handling.....	140
9.5.6	Collision Handling.....	140
9.5.7	Electrical Isolation.....	141
9.6	Detailed Repeater Functions and State Diagrams.....	141
9.6.1	State Diagram Notation.....	141
9.6.2	Data and Collision Handling.....	146
9.6.3	Preamble Regeneration.....	146
9.6.4	Fragment Extension.....	146
9.6.5	MAU Jabber Lockup Protection.....	146
9.6.6	Auto-Partitioning/Reconnection (Optional).....	146
9.7	Electrical Isolation.....	149
9.7.1	Environment A Requirements.....	149
9.7.2	Environment B Requirements.....	149
9.8	Reliability.....	149
9.9	Medium Attachment Unit and Baseband Medium Specification for a Vendor-Independent FOIRL.....	149
9.9.1	Scope.....	149
9.9.2	FOMAU Functional Specifications.....	151

SECTION	PAGE
9.9.3 FOMAU Electrical Characteristics	159
9.9.4 FOMAU/Optical Medium Interface	159
9.9.5 Characteristics of the Optical Fiber Cable Link Segment	160
9.9.6 System Requirements	161
9.9.7 Environmental Specifications	162
10. Medium Attachment Unit and Baseband Medium Specifications, Type 10BASE2	165
10.1 Scope	165
10.1.1 Overview	165
10.1.2 Definitions	166
10.1.3 Application Perspective: MAU and Medium Objectives	167
10.2 References	167
10.3 MAU Functional Specifications	167
10.3.1 MAU Physical Layer Functional Requirements	168
10.3.2 MAU Interface Messages	170
10.3.3 MAU State Diagrams	172
10.4 MAU-Medium Electrical Characteristics	173
10.4.1 MAU-to-Coaxial Cable Interface	172
10.4.2 MAU Electrical Characteristics	174
10.4.3 MAU-DTE Electrical Characteristics	175
10.5 Characteristics of Coaxial Cable System	175
10.5.1 Coaxial Cable Electrical Parameters	175
10.5.2 Coaxial Cable Physical Parameters	175
10.5.3 Total Segment DC Loop Resistance	177
10.6 Coaxial Trunk Cable Connectors	177
10.6.1 In-Line Coaxial Extension Connector	178
10.6.2 Coaxial Cable Terminator	178
10.6.3 MAU-to-Coaxial Cable Connection	178
10.7 System Considerations	178
10.7.1 Transmission System Model	178
10.7.2 Transmission System Requirements	179
10.8 Environmental Specifications	181
10.8.1 Safety Requirements	181
10.8.2 Electromagnetic Environment	181
10.8.3 Regulatory Requirements	182
11. Broadband Medium Attachment Unit and Broadband Medium Specifications, Type 10BROAD36	183
11.1 Scope	183
11.1.1 Overview	183
11.1.2 Definitions	185
11.1.3 MAU and Medium Objectives	186
11.1.4 Compatibility Considerations	186
11.1.5 Relationship to PLS and AUI	186
11.1.6 Mode of Operation	186
11.2 MAU Functional Specifications	187
11.2.1 MAU Functional Requirements	187
11.2.2 DTE PLS to MAU and MAU to DTE PLS Messages	189
11.2.3 MAU State Diagrams	190
11.3 MAU Characteristics	194
11.3.1 MAU-to-Coaxial Cable Interface	194
11.3.2 MAU Frequency Allocations	198
11.3.3 AUI Electrical Characteristics	198
11.3.4 MAU Transfer Characteristics	199
11.3.5 Reliability	206
11.4 System Considerations	206
11.4.1 Delay Budget and Network Diameter	206
11.4.2 MAU Operation with Packets Shorter than 512 Bits	206
11.5 Characteristics of the Coaxial Cable System	206
11.5.1 Electrical Requirements	206

SECTION	PAGE
11.5.2 Mechanical Requirements	207
11.5.3 Delay Requirements	207
11.6 Frequency Translator Requirements for the Single-Cable Version	207
11.6.1 Electrical Requirements	207
11.6.2 Mechanical Requirements	208
11.7 Environmental Specifications	208
11.7.1 Safety Requirements	208
11.7.2 Electromagnetic Environment	208
11.7.3 Temperature and Humidity	208
12. Physical Signaling, Medium Attachment, and Baseband Medium Specifications, Type 1BASE5	209
12.1 Introduction	209
12.1.1 Overview	209
12.1.2 Scope	209
12.1.3 Definitions	209
12.1.4 General Characteristics	211
12.1.5 Compatibility	211
12.1.6 Objectives of Type 1BASE5 Specifications	211
12.2 Architecture	211
12.2.1 Major Concepts	211
12.2.2 Application Perspective	213
12.2.3 Packet Structure	213
12.3 DTE Physical Signaling (PLS) Specification	214
12.3.1 Overview	214
12.3.2 Functional Specification	214
12.4 Hub Specification	221
12.4.1 Overview	221
12.4.2 Hub Structure	222
12.4.3 Hub PLS Functional Specification	222
12.5 Physical Medium Attachment (PMA) Specification	227
12.5.1 Overview	227
12.5.2 PLS-PMA Interface	227
12.5.3 Signal Characteristics	227
12.6 Medium Dependent Interface (MDI) Specification	235
12.6.1 Line Interface Connector	235
12.6.2 Connector Contact Assignments	235
12.6.3 Labeling	235
12.7 Cable Medium Characteristics	236
12.7.1 Overview	236
12.7.2 Transmission Parameters	236
12.7.3 Coupling Parameters	236
12.7.4 Noise Environment	238
12.8 Special Link Specification	238
12.8.1 Overview	238
12.8.2 Transmission Characteristics	238
12.8.3 Permitted Configurations	238
12.9 Timing	239
12.9.1 Overview	239
12.9.2 DTE Timing	239
12.9.3 Medium Timing	239
12.9.4 Special Link Timing	239
12.9.5 Hub Timing	239
12.10 Safety	240
12.10.1 Isolation	240
12.10.2 Telephony Voltages	240
13. System Considerations for Multisegment 10 Mb/s Baseband Networks	241
13.1 Overview	241
13.2 Definitions	241

SECTION	PAGE
13.3 Transmission System Model.....	241
14. Twisted-Pair Medium Attachment Unit (MAU) and Baseband Medium, Type 10BASE-T	245
14.1 Scope	245
14.1.1 Overview	245
14.1.2 Definitions	245
14.1.3 Application Perspective.....	247
14.1.4 Relationship to PLS and AUI	248
14.2 MAU Functional Specifications.....	248
14.2.1 MAU Functions	249
14.2.2 PMA Interface Messages.....	250
14.2.3 MAU State Diagrams	252
14.3 MAU Electrical Specifications.....	256
14.3.1 MAU-to-MDI Interface Characteristics	257
14.3.2 MAU-to-AUI Specification	265
14.4 Characteristics of the Simplex Link Segment.....	266
14.4.1 Overview	266
14.4.2 Transmission Parameters.....	266
14.4.3 Coupling Parameters	267
14.4.4 Noise Environment.....	267
14.5 MDI Specification.....	268
14.5.1 MDI Connectors.....	268
14.5.2 Crossover Function.....	269
14.6 System Considerations	270
14.7 Environmental Specifications	270
14.7.1 General Safety	270
14.7.2 Network Safety	270
14.7.3 Environment.....	271
14.8 MAU Labeling	271
14.9 Timing Summary	271

FIGURES

Fig 1-1 LAN Standard Relationship to the ISO Open Systems Interconnection (OSI) Reference Model	32
Fig 1-2 State Diagram Notation Example	33
Fig 1-3 Service Primitive Notation	34
Fig 2-1 Service Specification Relation to the LAN Model.....	37
Fig 3-1 MAC Frame Format	41
Fig 3-2 Address Field Format	42
Fig 4-1 MAC Sublayer Partitioning, Relationship to the ISO Open Systems Interconnection (OSI) Reference Model	46
Fig 4-2 CSMA/CD Media Access Control Functions	48
Fig 4-3 Relationship Among CSMA/CD Procedures	50
Fig 4-4 Control Flow Summary	
(a) TransmitFrame	51
(b) ReceiveFrame	52
Fig 4-5 Control Flow: MAC Sublayer	53
Fig 5-1 Relationship Between the Various Management Entities and Layer Entities According to the ISO Open Systems Interconnection (OSI) Reference Model.....	72
Fig 6-1 Service Specification Relationship to the IEEE 802.3 CSMA/CD LAN Model	83
Fig 7-1 Physical Layer Partitioning, Relationship to the ISO Open Systems Interconnection (OSI) Reference Model	87
Fig 7-2 Generalized MAU Model.....	89
Fig 7-3 PLS Reset and Identify Function	91
Fig 7-4 PLS Mode Function	92
Fig 7-5 PLS Output Function.....	93
Fig 7-6 PLS Input Function.....	97
Fig 7-7 PLS Error Sense Function	98
Fig 7-8 PLS Carrier Sense Function.....	99

FIGURES	PAGE
Fig 7-9	Interface Function for MAU with Conditioning 100-101
Fig 7-10	Examples of Manchester Waveforms 102
Fig 7-11	Differential Output Voltage, Loaded 104
Fig 7-12	Generalized Driver Waveform 105
Fig 7-13	Common-Mode Output Voltage 105
Fig 7-14	Driver Fault Conditions 106
Fig 7-15	Common-Mode Input Test 107
Fig 7-16	Receiver Fault Conditions 107
Fig 7-17	Common-Mode Transfer Impedance 109
Fig 7-18	Connector Locking Posts 111
Fig 7-19	Connector Slide Latch 112
Fig 7-20	Connector Hardware and AUI Cable Configuration 112
Fig 8-1	Physical Layer Partitioning, Relationship to the ISO Open Systems Interconnection (OSI) Reference Model 115
Fig 8-2	Interface Function: Simple MAU Without Isolate Capability 122
Fig 8-3	Interface Function: Simple MAU with Isolate Capability 123
Fig 8-4	Jabber Function 124
Fig 8-5	Recommended Driver Current Signal Levels 125
Fig 8-6	Typical Coaxial Trunk Cable Signal Waveform 125
Fig 8-7	Maximum Coaxial Cable Transfer Impedance 127
Fig 8-8	Coaxial Tap Connector Configuration Concepts 130
Fig 8-9	Typical Coaxial Tap Connection Circuit 131
Fig 8-10	Maximum Transmission Path 132
Fig 8-11	Minimal System Configuration 132
Fig 8-12	Minimal System Configuration Requiring a Repeater Set 132
Fig 8-13	An Example of a Large System with Maximum Transmission Paths 133
Fig 8-14	An Example of a Large Point-to-Point Link System (5140 ns) 133
Fig 9-1	Repeater Set, Coax-to-Coax Configuration 137
Fig 9-2	Repeater Unit State Diagram 144
Fig 9-3	Transmit Timer State Diagram for Port X 145
Fig 9-4	Tw2 State Diagram 145
Fig 9-5	MAU Jabber Lockup Protection State Diagram 145
Fig 9-6	Partitioning State Diagram for Port X 148
Fig 9-7	Schematic of the Vendor-Independent FOIRL and Its Relationship to the Repeater Unit 151
Fig 9-8	FOMAU Transmit, Receive, and Collision Functions State Diagram 157
Fig 9-9	FOMAU Jabber Function State Diagram 158
Fig 9-10	Low Light Level Detection Function State Diagram 158
Fig 10-1	Physical Layer Partitioning, Relationship to the ISO Open Systems Interconnection (OSI) Reference Model 165
Fig 10-2	MAU Interface Function 168
Fig 10-3	Jabber Function State Diagram 170
Fig 10-4	Driver Current Signal Levels 173
Fig 10-5	Coaxial Trunk Cable Signal Waveform 173
Fig 10-6	Maximum Coaxial Cable Transfer Impedance 176
Fig 10-7	Examples of Insulated Connector Cover 177
Fig 10-8	Maximum Transfer Path 179
Fig 10-9	The Minimum System Configuration 179
Fig 10-10	The Minimum System Configuration Requiring a Repeater Set 180
Fig 10-11	An Example of a Large Hybrid System 180
Fig 11-1	Physical Layer Partitioning, Relationship to the ISO Open Systems Interconnection (OSI) Reference Model 183
Fig 11-2	Broadband Cable Systems 184
Fig 11-3	Transmit Function Requirements 187
Fig 11-4	MAU State Diagram 192-193
Fig 11-5	MAU Jabber State Diagram 194
Fig 11-6	Packet Format and Timing Diagram (AUI to Coaxial Cable Interface) 196
Fig 11-7	Spectrum Mask for RF Data Signal 197
Fig 11-8	Transmit Out-of-Band Power Attenuation 197
Fig 11-9	Packet Format at Modulator Input 200

FIGURES	PAGE
Fig 11-10	Scrambler 201
Fig 11-11	Differential Encoder 201
Fig 11-12	Descrambler 202
Fig 11-13	No Collision Timing Diagram (Coax to AUI) 203
Fig 11-14	Collision Timing Diagram (RF Data to RF Collision Enforcement) 204
Fig 11-15	Collision Timing Diagram (Coaxial Cable Interface to AUI Circuit CI) 204
Fig 11-16	Timing at AUI for Zero-Length Coax 205
Fig 12-1	10BASE5 Relationship to the ISO Open Systems Interconnection (OSI) Reference Model and the IEEE 802.3 CSMA/CD LAN Model 210
Fig 12-2	Single Hub Network 212
Fig 12-3	Network With Two Levels of Hubs 212
Fig 12-4	Network With Four Levels of Hubs 213
Fig 12-5	Station Physical Signaling, Relationship to the ISO OSI Reference Model and the IEEE 802.3 CSMA/CD LAN Model 216
Fig 12-6	DTE PLS Output Function 217
Fig 12-7	DTE PLS Input Function 218
Fig 12-8	DTE PLS Error Sense Function 218
Fig 12-9	DTE PLS Carrier Sense Function 219
Fig 12-10	Examples of Manchester Waveforms 220
Fig 12-11	Examples of Collision Presence Waveforms 220
Fig 12-12	Hub Relationship to the OSI Reference Model and the IEEE 802.3 CSMA/CD LAN Model 221
Fig 12-13	Hub PLS Upward Transfer Function 224
Fig 12-14	Hub PLS Jabber Function for Port X 225
Fig 12-15	Hub PLS Downward Transfer Function 226
Fig 12-16	Physical Medium Attachment, Relationship to the OSI Reference Model and the IEEE 802.3 CSMA/CD LAN Model 228
Fig 12-17	Simulated Light Load 229
Fig 12-18	Simulated Heavy Load 229
Fig 12-19	Differential Output Voltage, Nominal Duration BT/2 229
Fig 12-20	Differential Output Voltage, Duration BT 229
Fig 12-21	Transmitter Waveform for Idle 231
Fig 12-22	Start-of-Idle Test Load #1 231
Fig 12-23	Start-of-Idle Test Load #2 231
Fig 12-24	Transmitter Impedance Balance 231
Fig 12-25	Common-Mode Output Voltage 232
Fig 12-26	Transmitter Common-Mode Tolerance 232
Fig 12-27	Common-Mode Impulse Test 233
Fig 12-28	Receiver Signal Envelope 233
Fig 12-29	Receiver Common-Mode Rejection 234
Fig 12-30	DTE and Hub Connector 235
Fig 12-31	Cable Connector 235
Fig 12-32	Cable Balance Test 237
Fig 13-1	Maximum Transmission Path with Three Coaxial Cable Segments 243
Fig 13-2	Example of Maximum Transmission Path Using Coaxial Cable Segments, 10BASE-T Link Segments, and Fiber Optic Link Segments 243
Fig 13-3	Example of Maximum Transmission Path with Three Repeater Sets, Four Link Segments (Two are 100 m 10BASE-T and Two are 1 km Fiber) 244
Fig 14-1	10BASE-T Relationship to the ISO Open Systems Interconnection (OSI) Reference Model and the IEEE 802.3 CSMA/CD LAN Model 246
Fig 14-2	Twisted-Pair Link 247
Fig 14-3	MAU Transmit, Receive, Loopback, and Collision Presence Functions State Diagram 253
Fig 14-4	signal_quality_error Message Test Function State Diagram 254
Fig 14-5	Jabber Function State Diagram 255
Fig 14-6	Link Integrity Test Function State Diagram 256
Fig 14-7	Twisted-Pair Model 257
Fig 14-8	Differential Output Voltage Test 258
Fig 14-9	Voltage Template 258
Fig 14-10	Transmitter Waveform for Start of TP_IDLE 260

FIGURES	PAGE	
Fig 14-11	Start-of-TP_ILDL Test Load.....	260
Fig 14-12	Transmitter Waveform for Link Test Pulse.....	261
Fig 14-13	Transmitter Impedance Balance and Common-Mode Rejection Test Circuit.....	262
Fig 14-14	Common-Mode Output Voltage Test Circuit.....	262
Fig 14-1E	Transmitter Fault Tolerance Test Circuit.....	263
Fig 14-16	Receiver Differential Input Voltage—Narrow Pulse.....	264
Fig 14-17	Receiver Differential Input Voltage—Wide Pulse.....	264
Fig 14-18	Receiver Common-Mode Rejection Test Circuit.....	265
Fig 14-19	Common-Mode Impulse Test Circuit.....	265
Fig 14-20	MAU MDI Connector.....	268
Fig 14-21	Twisted-Pair Link Segment Connector.....	268
Fig 14-22	Crossover Function	
	(a) External Crossover Function.....	269
	(b) MAU-Embedded Crossover Function.....	269

TABLES		PAGE
Table 8-1	Generation of Collision Presence Signal.....	119
Table 9-1	Maximum Allowable Timing Budget Contributions to the FOIRL System	
	Timing Budget.....	162
Table 10-1	Generation of Collision Presence Signal.....	169
Table 11.2-1	Single-Cable Frequency Allocations (Frequencies in MHz).....	198
Table 11.2-2	Dual-Cable Frequency Allocations (Frequencies in MHz).....	199
Table 11.4-1	Broadband Dual-Cable Systems—Physical Layer Delay Budget.....	206
Table 11.5-1	Cable System Electrical Requirements.....	207
Table 11.6-1	Frequency Translator Requirements.....	207
Table 13-1	Delays for Network Media Segments.....	241
Table 14-1	Voltage Template Values for Fig 14-9.....	259
Table 14-2	Maximum Timing Parameters.....	272

ANNEX	PAGE
Additional Reference Material.....	273

APPENDICES	PAGE
A. System Guidelines.....	275
A1. Baseband System Guidelines and Concepts.....	275
A1.1 Overall System Objectives.....	275
A1.2 Analog System Components and Parameter Values.....	275
A1.3 Minimum Frame Length Determination.....	276
A1.4 System Jitter Budgets.....	278
A2. System Parameters and Budgets for IRASEU.....	280
A2.1 Delay Budget.....	280
A2.2 Minimum Frame Length Determination.....	281
A2.3 Jitter Budget.....	282
A3. Example Crosstalk Computation for Multiple Disturbers.....	283
A4. 10BASE-T.....	284
A4.1 System Jitter Budget.....	284
A4.2 Filter Characteristics.....	285
A4.3 Notes for Conformance Testing.....	285
B. State Diagram, MAC Sublayer.....	287
B1. Introduction.....	287
B2. CSMA/CD Media Access Control State Machine Overview.....	287
B2.1 Transmit Component Overview.....	287
B2.2 Transmit Component Event Descriptions.....	287
B2.3 Transmit Component Action Descriptions.....	289
B2.4 Transmit Component State Descriptions.....	289
B3. Receive Component Overview.....	290
B3.1 Receive Component Event Descriptions.....	290

APPENDICES	PAGE
B3.2 Receive Component Action Descriptions	290
B3.3 Receive Component State Descriptions	291
 C. Application Context, Selected Medium Specifications.....	 292
C1. Introduction.....	292
C2. Type 10BASE5 Applications.....	292
C3. Type 10BASE2 Applications.....	293
C4. Type FOIRL Applications	293
 D. Receiver Wavelength Design Considerations	 294
 APPENDIX FIGURES	
Fig A1 Maximal System Configuration Bit Budget Apportionments.....	276
Fig A2 Typical Signal Waveforms	279
Fig A3 Worst-Case Signal Waveform Variations	279
Fig A4 MDNEXT Cumulative Probability Distribution.....	284
Fig B1 Transmit Component State Diagram.....	287
Fig B2 Receive Component State Diagram.....	290
 APPENDIX TABLES	
Table B1 Transmit Component State Transition.....	288
Table B2 Receive Component State Transition.....	290

Information technology—Local and metropolitan area networks—

Part 3: Carrier sense multiple access with collision detection (CSMA/CD) access method and physical layer specifications

1. Introduction

1.1 Overview

1.1.1 Basic Concepts. The Carrier Sense Multiple Access with Collision Detection (CSMA/CD) media access method is the means by which two or more stations share a common transmission medium. To transmit, a station waits (defers) for a quiet period on the medium (that is, no other station is transmitting) and then sends the intended message in bit-serial form. If, after initiating a transmission, the message collides with that of another station, then each transmitting station intentionally sends a few additional bytes to ensure propagation of the collision throughout the system. The station remains silent for a random amount of time (backoff) before attempting to transmit again. Each aspect of this access method process is specified in detail in subsequent sections of this standard.

This is a comprehensive standard for Local Area Networks employing CSMA/CD as the access method. This standard is intended to encompass several media types and techniques for signal rates of from 1 Mb/s to 20 Mb/s. This edition of the standard provides the necessary specifications for 10 Mb/s baseband and broadband systems, a 1 Mb/s baseband system, and a Repeater Unit.

1.1.2 Architectural Perspectives. There are two important ways to view local area network design corresponding to

- (1) *Architecture.* Emphasizing the logical divisions of the system and how they fit together.
- (2) *Implementation.* Emphasizing actual components, their packaging and interconnection.

This standard is organized along architectural lines, emphasizing the large-scale separation of the system into two parts: the Media Access Control (MAC) sublayer of the Data Link Layer, and the Physical Layer. These layers are intended to correspond closely to the lowest layers of the ISO Model for Open Systems Interconnection (see Fig 1-1). See ISO 7498:1984 [10].¹ The Logical Link Control (LLC) sublayer and MAC sublayer together encompass the functions intended for the Data Link Layer as defined in the OSI model.

1.1.2.1 An architectural organization of the standard has two main advantages:

- (1) *Clarity.* A clean overall division of the design along architectural lines makes the standard clearer.
- (2) *Flexibility.* Segregation of medium-dependent aspects in the Physical Layer allows the LLC and MAC sublayers to apply to a family of transmission media.

Partitioning the Data Link Layer allows various media access methods within the family of Local Area Network standards.

¹ The numbers in brackets correspond to those of the references listed in 1.3; when preceded by A, they correspond to those listed in the Annex.

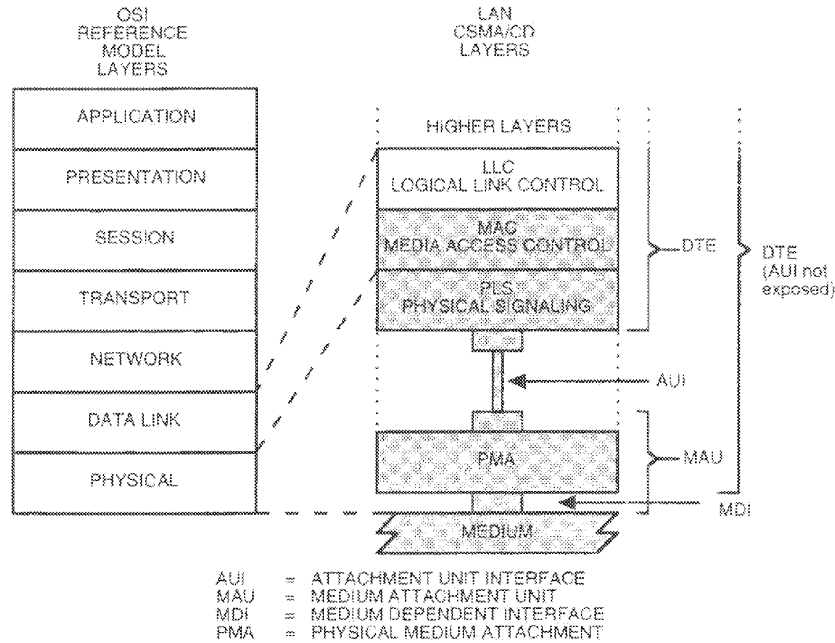

Fig 1-1
LAN Standard Relationship to the ISO Open Systems Interconnection (OSI) Reference Model

The architectural model is based on a set of interfaces that may be different from those emphasized in implementations. One critical aspect of the design, however, shall be addressed largely in terms of the implementation interfaces: compatibility.

1.1.2.2 Two important compatibility interfaces are defined within what is architecturally the Physical Layer.

- (1) *Medium-Dependent Interface (MDI)*. To communicate in a compatible manner, all stations shall adhere rigidly to the exact specification of physical media signals defined in Section 8 (and beyond) in this standard, and to the procedures that define correct behavior of a station. The medium-independent aspects of the LLC sublayer and the MAC sublayer should not be taken as detracting from this point; communication by way of the ISO 8802-3 [IEEE 802.3] Local Area Network requires complete compatibility at the Physical Medium interface (that is, the coaxial cable interface).
- (2) *Attachment Unit Interface (AUI)*. It is anticipated that most DTEs will be located some distance from their connection to the coaxial cable. A small amount of circuitry will exist in the Medium Attachment Unit (MAU) directly adjacent to the coaxial cable, while the majority of the hardware and all of the software will be placed within the DTE. The AUI is defined as a second compatibility interface. While conformance with this interface is not strictly necessary to ensure communication, it is highly recommended, since it allows maximum flexibility in intermixing MAUs and DTEs. The AUI may be optional or not specified for some implementations of this standard that are expected to be connected directly to the medium and so do not use a separate MAU or its interconnecting AUI cable. The PLS and PMA are then part of a single unit, and no explicit AUI specification is required.

1.1.3 **Layer Interfaces.** In the architectural model used here, the layers interact by way of well defined interfaces, providing services as specified in Sections 2 and 6. In general, the interface requirements are as follows.

- (1) The interface between the MAC sublayer and the LLC sublayer includes facilities for transmitting and receiving frames, and provides per-operation status information for use by higher-layer error recovery procedures.
- (2) The interface between the MAC sublayer and the Physical Layer includes signals for framing (carrier sense, transmit initiation) and contention resolution (collision detect), facilities for passing a pair of serial bit streams (transmit, receive) between the two layers, and a wait function for timing.

These interfaces are described more precisely in 4.3. Additional interfaces are necessary to allow higher level network management facilities to interact with these layers to perform operation, maintenance, and planning functions. Network management functions will be discussed in Section 5.

1.1.4 Application Areas. The applications environment for the Local Area Network is intended to be commercial and light industrial. Use of CSMA/CD LANs in home or heavy industrial environments, while not precluded, is not considered within the scope of this standard.

1.2 Notation

1.2.1 State Diagram Conventions. The operation of a protocol can be described by subdividing the protocol into a number of interrelated functions. The operation of the functions can be described by state diagrams. Each diagram represents the domain of a function and consists of a group of connected, mutually exclusive states. Only one state of a function is active at any given time (see Fig 1-2).

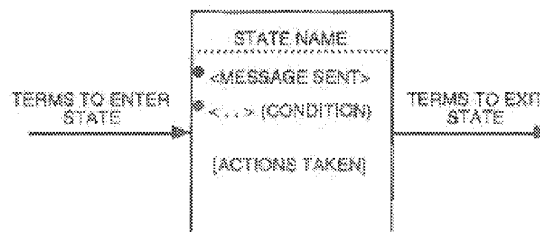

Key: { } = condition, for example, (if no collision)
 [] = action, for example, (reset PLS functions)
 * = logical AND
 + = logical OR
 Tw = Wait Time, Implementation dependent
 Td = Delay Timeout
 Tb = Backoff Timeout
 UCT = unconditional transition

Fig 1-2
State Diagram Notation Example

Each state that the function can assume is represented by a rectangle. These are divided into two parts by a horizontal line. In the upper part the state is identified by a name in capital letters. The lower part contains the name of any ON signal that is generated by the function. Actions are described by short phrases and enclosed in brackets.

All permissible transitions between the states of a function are represented graphically by arrows between them. A transition that is global in nature (for example, an exit condition from all states to the IDLE or RESET state) is indicated by an open arrow. Labels on transitions are qualifiers that must be fulfilled before the transition will be taken. The label UCT designates an unconditional transition. Qualifiers described by short phrases are enclosed in parentheses.

State transitions and sending and receiving of messages occur instantaneously. When a state is entered and the condition to leave that state is not immediately fulfilled, the state executes continuously, sending the messages and executing the actions contained in the state in a continuous manner.

Some devices described in this standard (e.g., repeaters) are allowed to have two or more ports. State diagrams capable of describing the operation of devices with an unspecified number of ports, required qualifier notation that allows testing for conditions at multiple ports. The notation used is a term that includes a description in parentheses of which ports must meet the term for the qualifier to be satisfied (e.g., ANY and ALL). It is also necessary to provide for term-assignment statements that assign a name to a port that satisfies a qualifier. The following convention is used to describe a term-assignment statement that is associated with a transition:

- (1) The character ":" (colon) is a delimiter used to denote that a term assignment statement follows.
- (2) The character "←" (left arrow) denotes assignment of the value following the arrow to the term preceding the arrow.

The state diagrams contain the authoritative statement of the functions they depict; when apparent conflicts between descriptive text and state diagrams arise, the state diagrams are to take precedence. This does not override, however, any explicit description in the text that has no parallel in the state diagrams.

The models presented by state diagrams are intended as the primary specifications of the functions to be provided. It is important to distinguish, however, between a model and a real implementation. The models are optimized for simplicity and clarity of presentation, while any realistic implementation may place heavier emphasis on efficiency and suitability to a particular implementation technology. It is the functional behavior of any unit that must match the standard, not its internal structure. The internal details of the model are useful only to the extent that they specify the external behavior clearly and precisely.

1.2.2 Service Specification Method and Notation. The service of a layer or sublayer is the set of capabilities that it offers to a user in the next higher (sub)layer. Abstract services are specified here by describing the service primitives and parameters that characterize each service. This definition of service is independent of any particular implementation (see Fig 1-3).

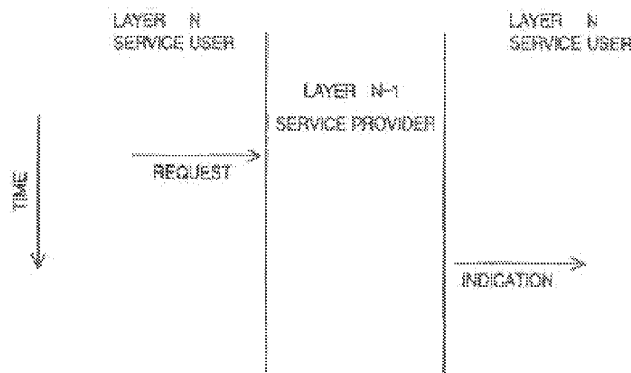

Fig 1-3
Service Primitive Notation

Specific implementations may also include provisions for interface interactions that have no direct end-to-end effects. Examples of such local interactions include interface flow control, status requests and indications, error notifications, and layer management. Specific implementation details are omitted from this service specification both because they will differ from implementation to implementation and because they do not impact the peer-to-peer protocols.

1.2.2.1 Classification of Service Primitives. Primitives are of two generic types:

- (1) **REQUEST.** The request primitive is passed from layer N to layer N-1 to request that a service be initiated.

- (2) **INDICATION.** The indication primitive is passed from layer N-1 to layer N to indicate an internal layer N-1 event that is significant to layer N. This event may be logically related to a remote service request, or may be caused by an event internal to layer N-1.

The service primitives are an abstraction of the functional specification and the user-layer interaction. The abstract definition does not contain local detail of the user/provider interaction. For instance, it does not indicate the local mechanism that allows a user to indicate that it is awaiting an incoming call. Each primitive has a set of zero or more parameters, representing data elements that shall be passed to qualify the functions invoked by the primitive. Parameters indicate information available in a user/provider interaction; in any particular interface, some parameters may be explicitly stated (even though not explicitly defined in the primitive) or implicitly associated with the service access point. Similarly, in any particular protocol specification, functions corresponding to a service primitive may be explicitly defined or implicitly available.

1.2.3 Physical Layer and Media Notation. Users of this standard need to reference which particular implementation is being used or identified. Therefore, a means of identifying each implementation is given by a simple, three-field, type notation that is explicitly stated at the beginning of each relevant section. In general, the Physical Layer type is specified by these fields:

<data rate in Mb/s> <medium type> <maximum segment length ($\times 100$ m)>

For example, the standard contains a 10 Mb/s baseband specification identified as "TYPE 10BASE5," meaning a 10 Mb/s baseband medium whose maximum segment length is 500 m. Each successive Physical Layer specification will state its own unique TYPE identifier along similar lines.

1.2.4 Physical Layer Message Notation. Messages generated within the Physical Layer, either within or between PLS and the MAU (that is, PMA circuitry), are designated by an italic type to designate either form of physical or logical message used to execute the physical layer signaling process (for example, *input_idle* or *mau_available*).

1.3 References

- [1] CISPR Publication 22 (1985), Limits and Methods of Measurement of Radio Interference Characteristics of Information Technology Equipment.³
- [2] IEC Publication 86-1, Radio-frequency cables, Part 1: General requirements and measuring methods.³
- [3] IEC Publication 96-1A, 1st Supplement to Radio-frequency cables, Part 1: Appendix Section 5.4, Terminated triaxial test method for transfer impedance up to 100 MHz.
- [4] IEC Publication 169-5 and -16, Radio-frequency connectors, Part 5: Radio-frequency coaxial connectors with inner diameter of outer conductor 6.5 mm (0.256 in) with bayonet lock—Characteristic impedance 50 ohms (Type BNC); Part 16: Radio-frequency coaxial connectors with inner diameter of outer conductor 7 mm (0.276 in) with screw coupling—Characteristic impedance 50 ohms (75 ohms) (Type N).
- [5] IEC Publication 380, Safety of electrically energized office machines.
- [6] IEC Publication 435, Safety of data processing equipment.

³CISPR documents are available from the International Electrotechnical Commission, 3 rue de Varembe, Case Postale 131, CH 1211, Genève 20, Switzerland/Suisse. CISPR documents are also available in the United States from the Sales Department, American National Standards Institute, 11 West 42nd Street, 18th Floor, New York, NY 10036, USA.

⁴IEC publications are available from IEC Sales Department, Case Postale 131, 3 rue de Varembe, CH-1211, Genève 20, Switzerland/Suisse. IEC publications are also available in the United States from the Sales Department, American National Standards Institute, 11 West 42nd Street, 18th Floor, New York, NY 10036, USA.

- [7] IEC Publication 807-2, Rectangular connectors for frequencies below 3 MHz, Part 2: Detail specification for a range of connectors with round contacts—Fixed solder contact types.
- [8] IEC Publication 950, Safety of Information Technology Equipment, Including Electrical Business Equipment.
- [9] ISO 2382-9 : 1984, Data processing—Vocabulary—Part 09: Data communication.⁴
- [10] ISO 7498 : 1984, Information processing systems—open systems interconnection—Basic reference model.
- [11] IEC Publication 60, High-voltage test techniques.
- [12] IEC Publication 68, Environmental testing.
- [13] IEC Publication 793-1, Optical fibres, Part 1: Generic specification.
- [14] IEC Publication 793-2, Optical fibres, Part 2: Product specifications.⁵
- [15] IEC Publication 794-1, Optical fibre cables, Part 1: Generic specification.
- [16] IEC Publication 794-2, Optical fibres cables, Part 2: Product specifications.
- [17] IEC Publication 825, Radiation safety of laser products, equipment classification, requirements, and user's guide.
- [18] IEC Publication 874-1, Connectors for optical fibres and cables, Part 1: Generic specification.
- [19] IEC Publication 874-2, Connectors for optical fibres and cables, Part 2: Sectional specification for fibre optic connector type F-SMA.
- [20] ISO/IEC 7498-4 : 1989, Information processing systems—Open Systems Interconnection—Basic Reference Model—Part 4: Management Framework.
- [21] ISO 8877 : 1987, Information processing systems—Interface connector and contact assignments for ISDN basic access interface located at reference points S and T.

Local and national standards such as those supported by ANSI, EIA, IEEE, MIL, NFPA, and UL are not a formal part of the ISO/IEC 8802-3 standard. Reference to such local or national standards may be useful resource material and are identified by a bracketed number beginning with the letter A and located in Annex A.

1.4 Definitions. The definitions used in this standard are consistent with ISO 2382-9:1984 [9]. A more specific Part 25, pertaining to LAN systems, is in development.

⁴ISO publications are available from the ISO Central Secretariat, Case Postale 56, 1 rue de Varembe, CH-1211, Genève 20, Switzerland/Suisse. ISO publications are also available in the United States from the Sales Department, American National Standards Institute, 11 West 42nd Street, 13th Floor, New York, NY 10036, USA.

⁵ Subsection 9.9 is to be read with the understanding that the following changes to IEC Publication 793-2 [14] have been requested:

(1) Correction of the numerical aperture tolerance in Table III to ± 0.015 .

(2) Addition of another bandwidth category, of ≥ 150 MHz referred to 1 km, for the type A1b fiber in Table III.

2. MAC Service Specification

2.1 Scope and Field of Application. This section specifies the services provided by the Media Access Control (MAC) sublayer to the Logical Link Control (LLC) sublayer for the ISO [IEEE] Local Area Network standard (see Fig 2-1). The services are described in an abstract way and do not imply any particular implementation, or any exposed interface. There is not necessarily a one-to-one correspondence between the primitives and the formal procedures and interfaces described in 4.2 and 4.3.

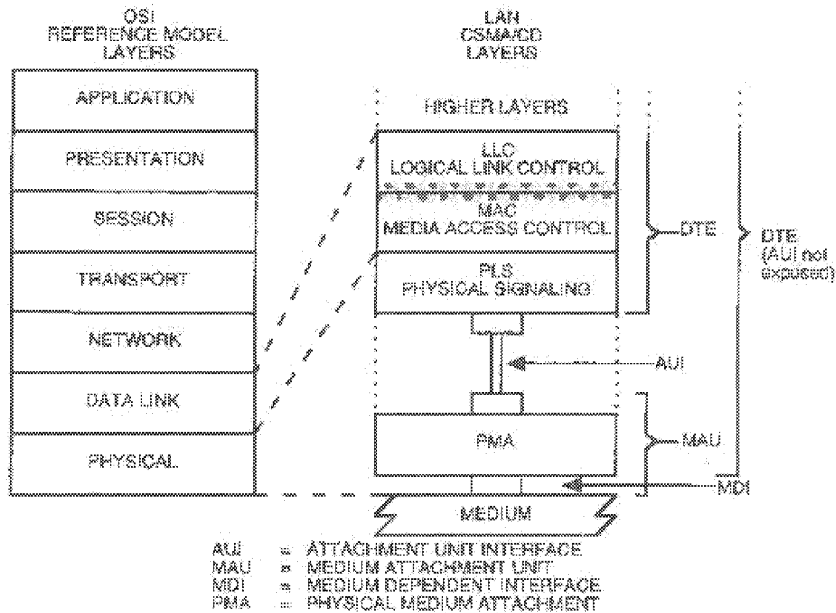

Fig 2-1
Service Specification Relation to the LAN Model

2.2 Overview of the Service

2.2.1 General Description of Services Provided by the Layer. The services provided by the MAC sublayer allow the local LLC sublayer entity to exchange LLC data units with peer LLC sublayer entities. Optional support may be provided for resetting the MAC sublayer entity to a known state.

2.2.2 Model Used for the Service Specification. The model used in this service specification is identical to that used in 1.2.

2.2.3 Overview of Interactions

MA_DATA.request
MA_DATA.indication

2.2.4 Basic Services and Options. The MA_DATA.request and MA_DATA.indication service primitives described in this section are considered mandatory.

2.3 Detailed Service Specification

2.3.1 MA_DATA.request

2.3.1.1 Function. This primitive defines the transfer of data from a local LLC sublayer entity to a single peer LLC entity or multiple peer LLC entities in the case of group addresses.

2.3.1.2 Semantics of the Service Primitive. The semantics of the primitive are as follows:

```
MA_DATA.request (
    destination_address,
    m_sdu,
    service_class
)
```

The `destination_address` parameter may specify either an individual or a group MAC entity address. It must contain sufficient information to create the DA field that is appended to the frame by the local MAC sublayer entity and any physical information. The `m_sdu` parameter specifies the MAC service data unit to be transmitted by the MAC sublayer entity. There is sufficient information associated with `m_sdu` for the MAC sublayer entity to determine the length of the data unit. The `service_class` parameter indicates a quality of service requested by LLC or higher layer (see 2.3.1.5).

2.3.1.3 When Generated. This primitive is generated by the LLC sublayer entity whenever data shall be transferred to a peer LLC entity or entities. This can be in response to a request from higher protocol layers or from data generated internally to the LLC sublayer, such as required by Type 2 service.

2.3.1.4 Effect of Receipt. The receipt of this primitive will cause the MAC entity to append all MAC specific fields, including DA, SA, and any fields that are unique to the particular media access method, and pass the properly formed frame to the lower protocol layers for transfer to the peer MAC sublayer entity or entities.

2.3.1.5 Additional Comments. The CSMA/CD MAC protocol provides a single quality of service regardless of the `service_class` requested.

2.3.2 MA_DATA.indication

2.3.2.1 Function. This primitive defines the transfer of data from the MAC sublayer entity to the LLC sublayer entity or entities in the case of group addresses.

2.3.2.2 Semantics of the Service Primitive. The semantics of the primitive are as follows:

```
MA_DATA.indication (
    destination_address,
    source_address,
    m_sdu,
    reception_status
)
```

The `destination_address` parameter may be either an individual or a group address as specified by the DA field of the incoming frame. The `source_address` parameter is an individual address as specified by the SA field of the incoming frame. The `m_sdu` parameter specifies the MAC service data unit as received by the local MAC entity. The `reception_status` parameter is used to pass status information to the peer LLC sublayer entity.

2.3.2.3 When Generated. The `MA_DATA.indication` is passed from the MAC sublayer entity to the LLC sublayer entity or entities to indicate the arrival of a frame to the local MAC sublayer entity. Such

frames are reported only if they are validly formed, received without error, and their destination address designates the local MAC entity.

2.3.2.4 Effect of Receipt. The effect of receipt of this primitive by the LLC sublayer is unspecified.

2.3.2.5 Additional Comments. If the local MAC sublayer entity is designated by the destination_address parameter of an MA_DATA.request, the indication primitive will also be invoked by the MAC entity to the local LLC entity. This full duplex characteristic of the MAC sublayer may be due to unique functionality within the MAC sublayer or full duplex characteristics of the lower layers (for example, all frames transmitted to the broadcast address will invoke MA_DATA.indication at all stations in the network including the station that generated the request).

3. Media Access Control Frame Structure

3.1 Overview. This section defines in detail the frame structure for data communication systems using local area network MAC procedures. It defines the relative positions of the various components of the MAC frame. It defines the method for representing station addresses. It defines a partition of the address space into individual (single station) and group (multicast or multistation) addresses, and into user administered and globally administered addresses.

3.1.1 MAC Frame Format. Figure 3-1 shows the eight fields of a frame: the preamble, Start Frame Delimiter (SFD), the addresses of the frame's source and destination, a length field to indicate the length of the following field containing the LLC data to be transmitted, a field that contains padding if required, and the frame check sequence field containing a cyclic redundancy check value to detect errors in received frames. Of these eight fields, all are of fixed size except the LLC data and PAD fields, which may contain any integer number of octets between the minimum and maximum values determined by the specific implementation of the CSMA/CD Media Access mechanism. See 4.4 for particular implementations.

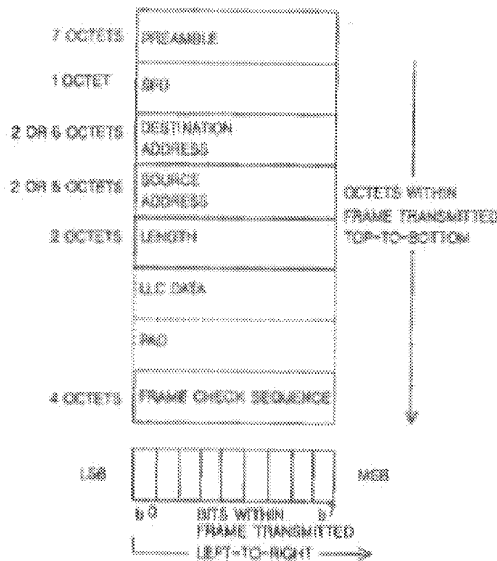

Fig 3-1
MAC Frame Format

The minimum and maximum frame size limits in 4.4 refer to that portion of the frame from the destination address field through the frame check sequence field, inclusive.

Relative to Fig 3-1, the octets of a frame are transmitted from top to bottom, and the bits of each octet are transmitted from left to right.

3.2 Elements of the MAC Frame

3.2.1 Preamble Field. The preamble field is a 7-octet field that is used to allow the PLS circuitry to reach its steady-state synchronization with the received frame timing (see 4.2.5).

3.2.2 Start Frame Delimiter (SFD) Field. The SFD field is the sequence 10101011. It immediately follows the preamble pattern and indicates the start of a frame.

3.2.3 Address Fields. Each MAC frame shall contain two address fields: the Destination Address field and the Source Address field, in that order. The Destination Address field shall specify the destination addressee(s) for which the frame is intended. The Source Address field shall identify the station from which the frame was initiated. The representation of each address field shall be as follows (see Fig 3-2):

- (1) Each address field shall contain either 16 bits or 48 bits. However, at any given time, the Source and Destination Address size shall be the same for all stations on a particular local area network.
- (2) The support of 16 or 48 bit address length for Source and Destination Address shall be left to the manufacturer as an implementation decision. There is no requirement that manufacturers support both sizes.
- (3) The first bit (LSB) shall be used in the Destination Address field as an address type designation bit to identify the Destination Address either as an individual or as a group address. In the Source Address field, the first bit is reserved and set to 0. If this bit is 0, it shall indicate that the address field contains an individual address. If this bit is 1, it shall indicate that the address field contains a group address that identifies none, one or more, or all of the stations connected to the local area network.
- (4) For 48 bit addresses, the second bit shall be used to distinguish between locally or globally administered addresses. For globally administered (or U, universal) addresses, the bit is set to 0. If an address is to be assigned locally, this bit shall be set to 1. Note that for the broadcast address, this bit is also a 1.
- (5) Each octet of each address field shall be transmitted least significant bit first.

48 BIT ADDRESS FORMAT

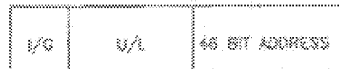

16 BIT ADDRESS FORMAT

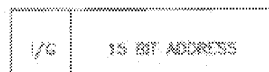

I/G = 0 INDIVIDUAL ADDRESS
I/G = 1 GROUP ADDRESS
U/L = 0 GLOBALLY ADMINISTERED ADDRESS
U/L = 1 LOCALLY ADMINISTERED ADDRESS

Fig 3-2
Address Field Format

3.2.3.1 Address Designation. A MAC sublayer address is of one of two types:

- (1) *Individual Address.* The address associated with a particular station on the network.
- (2) *Group Address.* A multidestination address, associated with one or more stations on a given network. There are two kinds of multicast address:
 - (a) *Multicast-Group Address.* An address associated by higher-level convention with a group of logically related stations.
 - (b) *Broadcast Address.* A distinguished, predefined multicast address that always denotes the set of all stations on a given local area network.

All 1's in the Destination Address field (for 16 or 48 bit address size LANs) shall be predefined to be the Broadcast address. This group shall be predefined for each communication medium to consist of all stations

actively connected to that medium; it shall be used to broadcast to all the active stations on that medium. All stations shall be able to recognize the Broadcast address. It is not necessary that a station be capable of generating the Broadcast address.

The address space shall also be partitioned into locally administered and globally administered addresses. The nature of a body and the procedures by which it administers these global (U) addresses is beyond the scope of this standard.⁶

3.2.4 Destination Address Field. The Destination Address field specifies the station(s) for which the frame is intended. It may be an individual or multicast (including broadcast) address.

3.2.5 Source Address Field. The Source Address field specifies the station sending the frame. The Source Address field is not interpreted by the CSMA/CD MAC sublayer.

3.2.6 Length Field. The length field is a 2-octet field whose value⁷ indicates the number of LLC data octets in the data field. If the value is less than the minimum required for proper operation of the protocol, a PAD field (a sequence of octets) will be added at the end of the data field but prior to the FCS field, specified below. The procedure that determines the size of the pad field is specified in 4.2.8. The length field is transmitted and received with the high order octet first.

3.2.7 Data and PAD Fields. The data field contains a sequence of n octets. Full data transparency is provided in the sense that any arbitrary sequence of octet values may appear in the data field up to a maximum number specified by the implementation of this standard that is used. A minimum frame size is required for correct CSMA/CD protocol operation and is specified by the particular implementation of the standard. If necessary, the data field is extended by appending extra bits (that is, a pad) in units of octets after the LLC data field but prior to calculating and appending the FCS. The size of the pad, if any, is determined by the size of the data field supplied by LLC and the minimum frame size and address size parameters of the particular implementation. The maximum size of the data field is determined by the maximum frame size and address size parameters of the particular implementation.

The length of PAD field required for LLC data that is n octets long is $\max(0, \text{minFrameSize} - (5 \times n + 2 \times \text{addressSize} + 48))$ bits. The maximum possible size of the LLC data field is $\text{maxFrameSize} - (2 \times \text{addressSize} + 48)/8$ octets. See 4.4 for a discussion of implementation parameters; see 4.2.3.3 for a discussion of the minFrameSize .

3.2.8 Frame Check Sequence Field. A cyclic redundancy check (CRC) is used by the transmit and receive algorithms to generate a CRC value for the FCS field. The frame check sequence (FCS) field contains a 4-octet (32-bit) cyclic redundancy check (CRC) value. This value is computed as a function of the contents of the source address, destination address, length, LLC data and pad (that is, all fields except the preamble, SFD, and FCS). The encoding is defined by the following generating polynomial.

$$G(x) = x^{32} + x^{26} + x^{23} + x^{22} + x^{16} + x^{12} + x^{11} + x^{10} + x^8 + x^7 + x^5 + x^4 + x^2 + x + 1$$

Mathematically, the CRC value corresponding to a given frame is defined by the following procedure:

- (1) The first 32 bits of the frame are complemented.
- (2) The n bits of the frame are then considered to be the coefficients of a polynomial $M(x)$ of degree $n-1$. (The first bit of the Destination Address field corresponds to the $x^{(n-1)}$ term and the last bit of the data field corresponds to the x^0 term.)
- (3) $M(x)$ is multiplied by x^{32} and divided by $G(x)$, producing a remainder $R(x)$ of degree <31 .
- (4) The coefficients of $R(x)$ are considered to be a 32-bit sequence.
- (5) The bit sequence is complemented and the result is the CRC.

⁶For information on how to use MAC addresses, see IEEE Std 802-1990, Overview and Architecture. To apply for an Organizationally Unique Identifier for building a MAC address, contact the Registration Authority, IEEE Standards Department, P.O. Box 1331, 445 Hous Lane, Piscataway, NJ 08855-1331, USA; (908) 662-3813; fax (908) 662-1871.

⁷Packets with a length field value greater than those specified in 4.1.3 may be ignored, discarded, or used in a private manner. The use of such packets is beyond the scope of this standard.

The 32 bits of the CRC value are placed in the frame check sequence field so that the x^{31} term is the left-most bit of the first octet, and the x^0 term is the right most bit of the last octet. (The bits of the CRC are thus transmitted in the order $x^{31}, x^{30}, \dots, x^1, x^0$.) See reference [A18].

3.3 Order of Bit Transmission. Each octet of the MAC frame, with the exception of the FCS, is transmitted low-order bit first.

3.4 Invalid MAC Frame. An invalid MAC frame shall be defined as one that meets at least one of the following conditions:

- (1) The frame length is inconsistent with the length field.
- (2) It is not an integral number of octets in length.
- (3) The bits of the incoming frame (exclusive of the FCS field itself) do not generate a CRC value identical to the one received.

The contents of invalid MAC frames shall not be passed to LLC. The occurrence of invalid MAC frames may be communicated to network management.

4. Media Access Control

4.1 Functional Model of the Media Access Control Method

4.1.1 Overview. The architectural model described in Section 1 is used in this section to provide a functional description of the Local Area Network CSMA/CD MAC sublayer.

The MAC sublayer defines a medium-independent facility, built on the medium-dependent physical facility provided by the Physical Layer, and under the access-layer-independent local area network LLC sublayer. It is applicable to a general class of local area broadcast media suitable for use with the media access discipline known as Carrier Sense Multiple Access with Collision Detection (CSMA/CD).

The LLC sublayer and the MAC sublayer together are intended to have the same function as that described in the OSI model for the Data Link Layer alone. In a broadcast network, the notion of a data link between two network entities does not correspond directly to a distinct physical connection. Nevertheless, the partitioning of functions presented in this standard requires two main functions generally associated with a data link control procedure to be performed in the MAC sublayer. They are as follows:

- (1) Data encapsulation (transmit and receive)
 - (a) Framing (frame boundary delimitation, frame synchronization)
 - (b) Addressing (handling of source and destination addresses)
 - (c) Error detection (detection of physical medium transmission errors)
- (2) Media Access Management
 - (a) Medium allocation (collision avoidance)
 - (b) Contention resolution (collision handling)

The remainder of this section provides a functional model of the CSMA/CD MAC method.

4.1.2 CSMA/CD Operation. This section provides an overview of frame transmission and reception in terms of the functional model of the architecture. This overview is descriptive, rather than definitional; the formal specifications of the operations described here are given in 4.2 and 4.3. Specific implementations for CSMA/CD mechanisms that meet this standard are given in 4.4. Figure 4-1 provides the architectural model described functionally in the sections that follow.

The Physical Layer Signaling (PLS) component of the Physical Layer provides an interface to the MAC sublayer for the serial transmission of bits onto the physical media. For completeness, in the operational description that follows some of these functions are included as descriptive material. The concise specification of these functions is given in 4.2 for the MAC functions and in Section 7 for PLS.

Transmit frame operations are independent from the receive frame operations. A transmitted frame addressed to the originating station will be received and passed to the LLC sublayer at that station. This characteristic of the MAC sublayer may be implemented by functionality within the MAC sublayer or full duplex characteristics of portions of the lower layers.

4.1.2.1 Normal Operation

4.1.2.1.1 Transmission Without Contention. When a LLC sublayer requests the transmission of a frame, the Transmit Data Encapsulation component of the CSMA/CD MAC sublayer constructs the frame from the LLC-supplied data. It appends a preamble and a start of frame delimiter to the beginning of the frame. Using information passed by the LLC sublayer, the CSMA/CD MAC sublayer also appends a PAD at the end of the MAC information field of sufficient length to ensure that the transmitted frame length satisfies a minimum frame size requirement (see 4.2.3.3). It also appends destination and source addresses, a length count field, and a frame check sequence to provide for error detection. The frame is then handed to the Transmit Media Access Management component in the MAC sublayer for transmission.

Transmit Media Access Management then attempts to avoid contention with other traffic on the medium by monitoring the carrier sense signal provided by the Physical Layer Signaling (PLS) component and deferring to passing traffic. When the medium is clear, frame transmission is initiated (after a brief inter-

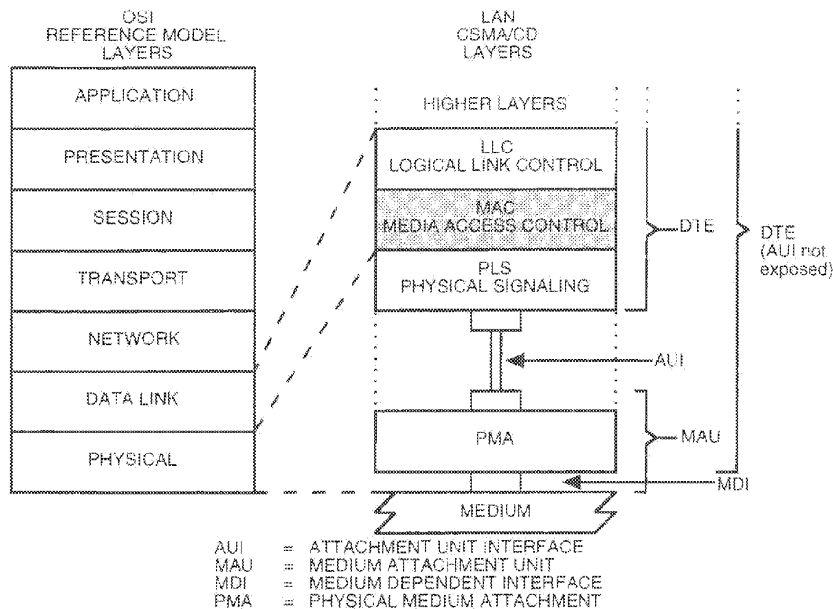

Fig 4-1
MAC Sublayer Partitioning, Relationship to the ISO Open Systems Interconnection (OSI) Reference Model

frame delay to provide recovery time for other CSMA/CD MAC sublayers and for the physical medium) The MAC sublayer then provides a serial stream of bits to the PLS interface for transmission.

The PLS performs the task of actually generating the electrical signals on the medium that represent the bits of the frame. Simultaneously, it monitors the medium and generates the collision detect signal, which, in the contention-free case under discussion, remains off for the duration of the frame. A functional description of the Physical Layer is given in Sections 7 and beyond.

When transmission has completed without contention, the CSMA/CD MAC sublayer so informs the LLC sublayer using the LLC to MAC interface and awaits the next request for frame transmission.

4.1.2.1.2 Reception Without Contention. At each receiving station, the arrival of a frame is first detected by the PLS, which responds by synchronizing with the incoming preamble, and by turning on the carrier sense signal. As the encoded bits arrive from the medium, they are decoded and translated back into binary data. The PLS passes subsequent bits up to the MAC sublayer, where the leading bits are discarded, up to and including the end of the preamble and Start Frame Delimiter.

Meanwhile, the Receive Media Access Management component of the MAC sublayer, having observed carrier sense, has been waiting for the incoming bits to be delivered. Receive Media Access Management collects bits from the PLS as long as the carrier sense signal remains on. When the carrier sense signal is removed, the frame is truncated to an octet boundary, if necessary, and passed to Receive Data Decapsulation for processing.

Receive Data Decapsulation checks the frame's Destination Address field to decide whether the frame should be received by this station. If so, it passes the Destination Address (DA), the Source Address (SA), and the LLC data unit (LLCDU) to the LLC sublayer along with an appropriate status code indicating `reception_complete` or `reception_too_long`. It also checks for invalid MAC frames by inspecting the frame check sequence to detect any damage to the frame enroute, and by checking for proper octet-boundary alignment of the end of the frame. Frames with a valid FCS may also be checked for proper octet boundary alignment.

4.1.2.2 Access Interference and Recovery. If multiple stations attempt to transmit at the same time, it is possible for them to interfere with each other's transmissions, in spite of their attempts to avoid

this by deferring. When transmissions from two stations overlap, the resulting contention is called a collision. A given station can experience a collision during the initial part of its transmission (the collision window) before its transmitted signal has had time to propagate to all stations on the CSMA/CD medium. Once the collision window has passed, a transmitting station is said to have acquired the medium; subsequent collisions are avoided since all other (properly functioning) stations can be assumed to have noticed the signal (by way of carrier sense) and to be deferring to it. The time to acquire the medium is thus based on the round-trip propagation time of the physical layer whose elements include the PLS, PMA, and physical medium.

In the event of a collision, the transmitting station's Physical Layer initially notices the interference on the medium and then turns on the collision detect signal. This is noticed in turn by the Transmit Media Access Management component of the MAC sublayer, and collision handling begins. First, Transmit Media Access Management enforces the collision by transmitting a bit sequence called jam. In 4.4 an implementation that uses this enforcement procedure is provided. This ensures that the duration of the collision is sufficient to be noticed by the other transmitting station(s) involved in the collision. After the jam is sent, Transmit Media Access Management terminates the transmission and schedules another transmission attempt after a randomly selected time interval. Retransmission is attempted again in the face of repeated collisions. Since repeated collisions indicate a busy medium, however, Transmit Media Access Management attempts to adjust to the medium load by backing off (voluntarily delaying its own retransmissions to reduce its load on the medium). This is accomplished by expanding the interval from which the random retransmission time is selected on each successive transmit attempt. Eventually, either the transmission succeeds, or the attempt is abandoned on the assumption that the medium has failed or has become overloaded.

At the receiving end, the bits resulting from a collision are received and decoded by the PLS just as are the bits of a valid frame. Fragmentary frames received during collisions are distinguished from valid transmissions by the MAC sublayer's Receive Media Access Management component.

4.1.3 Relationships to LLC Sublayer and Physical Layer. The CSMA/CD MAC sublayer provides services to the LLC sublayer required for the transmission and reception of frames. Access to these services is specified in 4.3. The CSMA/CD MAC sublayer makes a best effort to acquire the medium and transfer a serial stream of bits to the PLS. Although certain errors are reported to the LLC, error recovery is not provided by MAC. Error recovery may be provided by the LLC or higher (sub)layers.

4.1.4 CSMA/CD Access Method Functional Capabilities. The following summary of the functional capabilities of the CSMA/CD MAC sublayer is intended as a quick reference guide to the capabilities of the standard, as depicted in Fig 4-2:

- (1) For Frame Transmission
 - (a) Accepts data from the LLC sublayer and constructs a frame
 - (b) Presents a bit-serial data stream to the physical layer for transmission on the medium

NOTE: Assumes data passed from the LLC sublayer are octet multiples.
- (2) For Frame Reception
 - (a) Receives a bit-serial data stream from the physical layer
 - (b) Presents to the LLC sublayer frames that are either broadcast frames or directly addressed to the local station
 - (c) Discards or passes to Network Management all frames not addressed to the receiving station
- (3) Defers transmission of a bit-serial stream whenever the physical medium is busy
- (4) Appends proper FCS value to outgoing frames and verifies full octet boundary alignment
- (5) Checks incoming frames for transmission errors by way of FCS and verifies octet boundary alignment
- (6) Delays transmission of frame bit stream for specified interframe gap period
- (7) Halts transmission when collision is detected
- (8) Schedules retransmission after a collision until a specified retry limit is reached
- (9) Enforces collision to ensure propagation throughout network by sending jam message
- (10) Discards received transmissions that are less than a minimum length
- (11) Appends preamble, Start Frame Delimiter, DA, SA, length count, and FCS to all frames, and inserts pad field for frames whose LLC data length is less than a minimum value

- (12) Removes preamble, Start Frame Delimiter, DA, SA, length count, FCS and pad field (if necessary) from received frames

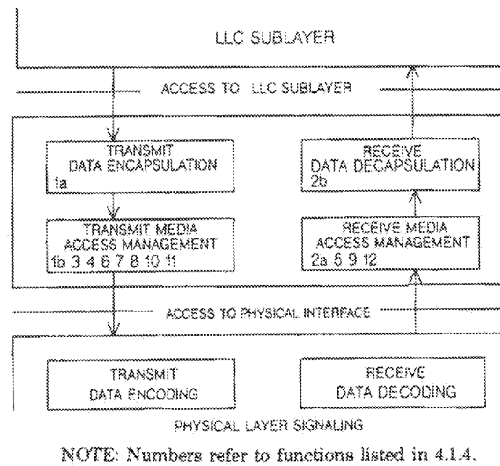

Fig 4-2
CSMA/CD Media Access Control Functions

4.2 CSMA/CD Media Access Control Method (MAC): Precise Specification

4.2.1 Introduction. A precise algorithmic definition is given in this section, providing procedural model for the CSMA/CD MAC process with a program in the computer language Pascal. See references [A2] and [A17] for resource material. Note whenever there is any apparent ambiguity concerning the definition of some aspect of the CSMA/CD MAC method, it is the Pascal procedural specification in 4.2.7 through 4.2.10 which should be consulted for the definitive statement. Sections 4.2.2 through 4.2.6 provide, in prose, a description of the access mechanism with the formal terminology to be used in the remaining subsections.

4.2.2 Overview of the Procedural Model. The functions of the CSMA/CD MAC method are presented below, modeled as a program written in the computer language Pascal. This procedural model is intended as the primary specification of the functions to be provided in any CSMA/CD MAC sublayer implementation. It is important to distinguish, however, between the model and a real implementation. The model is optimized for simplicity and clarity of presentation, while any realistic implementation shall place heavier emphasis on such constraints as efficiency and suitability to a particular implementation technology or computer architecture. In this context, several important properties of the procedural model shall be considered.

4.2.2.1 Ground Rules for the Procedural Model

- (1) First, it shall be emphasized that *the description of the MAC sublayer in a computer language is in no way intended to imply that procedures shall be implemented as a program executed by a computer.* The implementation may consist of any appropriate technology including hardware, firmware, software, or any combination.
- (2) Similarly, it shall be emphasized that it is the behavior of any MAC sublayer implementations that shall match the standard, not their internal structure. The internal details of the procedural model are useful only to the extent that they help specify that behavior clearly and precisely.
- (3) The handling of incoming and outgoing frames is rather stylized in the procedural model, in the sense that frames are handled as single entities by most of the MAC sublayer and are only serial-

ized for presentation to the Physical Layer. In reality, many implementations will instead handle frames serially on a bit, octet or word basis. This approach has not been reflected in the procedural model, since this only complicates the description of the functions without changing them in any way.

- (4) The model consists of algorithms designed to be executed by a number of concurrent processes; these algorithms collectively implement the CSMA/CD procedure. The timing dependencies introduced by the need for concurrent activity are resolved in two ways:
 - (a) *Processes Versus External Events.* It is assumed that the algorithms are executed "very fast" relative to external events, in the sense that a process never falls behind in its work and fails to respond to an external event in a timely manner. For example, when a frame is to be received, it is assumed that the Media Access procedure ReceiveFrame is always called well before the frame in question has started to arrive.
 - (b) *Processes Versus Processes.* Among processes, no assumptions are made about relative speeds of execution. This means that each interaction between two processes shall be structured to work correctly independent of their respective speeds. Note, however, that the timing of interactions among processes is often, in part, an indirect reflection of the timing of external events, in which case appropriate timing assumptions may still be made.

It is intended that the concurrency in the model reflect the parallelism intrinsic to the task of implementing the LLC and MAC procedures, although the actual parallel structure of the implementations is likely to vary.

4.2.2.3 Use of Pascal in the Procedural Model. Several observations need to be made regarding the method with which Pascal is used for the model. Some of these observations are as follows:

- (1) Some limitations of the language have been circumvented to simplify the specification:
 - (a) The elements of the program (variables and procedures, for example) are presented in logical groupings, in top-down order. Certain Pascal ordering restrictions have thus been circumvented to improve readability.
 - (b) The *process* and *cycle* constructs of Concurrent Pascal, a Pascal derivative, have been introduced to indicate the sites of autonomous concurrent activity. As used here, a process is simply a parameterless procedure that begins execution at "the beginning of time" rather than being invoked by a procedure call. A cycle statement represents the main body of a process and is executed repeatedly forever.
 - (c) The lack of variable array bounds in the language has been circumvented by treating frames as if they are always of a single fixed size (which is never actually specified). The size of a frame depends on the size of its data field, hence the value of the "pseudo-constant" frameSize should be thought of as varying in the long-term, even though it is fixed for any given frame.
 - (d) The use of a variant record to represent a frame (as fields and as bits) follows the spirit but not the letter of the Pascal Report, since it allows the underlying representation to be viewed as two different data types.
- (2) The model makes no use of any explicit interprocess synchronization primitives. Instead, all interprocess interaction is done by way of carefully stylized manipulation of shared variables. For example, some variables are set by only one process and inspected by another process in such a manner that the net result is independent of their execution speeds. While such techniques are not generally suitable for the construction of large concurrent programs, they simplify the model and more nearly resemble the methods appropriate to the most likely implementation technologies (microcode, hardware state-machines, etc.)

4.2.2.3 Organization of the Procedural Model. The procedural model used here is based on five cooperating concurrent processes. Three are actually defined in the MAC sublayer. The remaining two processes are provided by the clients of the MAC sublayer (which may include the LLC sublayer) and utilize the interface operations provided by the MAC sublayer. The five processes are thus:

- (1) Frame Transmitter Process
- (2) Frame Receiver Process
- (3) Bit Transmitter Process

- (4) Bit Receiver Process
- (5) Deference Process

This organization of the model is illustrated in Fig 4-3 and reflects the fact that the communication of entire frames is initiated by the client of the MAC sublayer; while the timing of collision backoff and of individual bit transfers is based on interactions between the MAC sublayer and the Physical-Layer-dependent bit time.

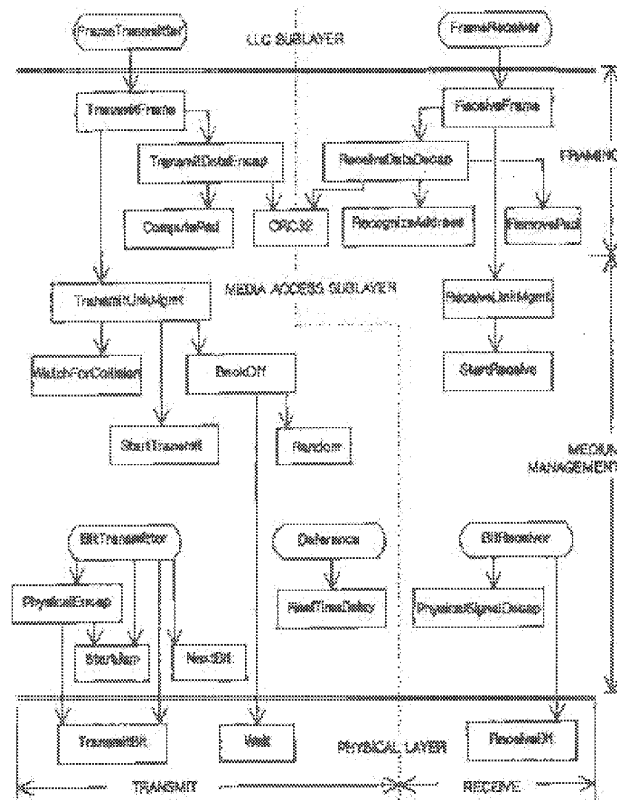
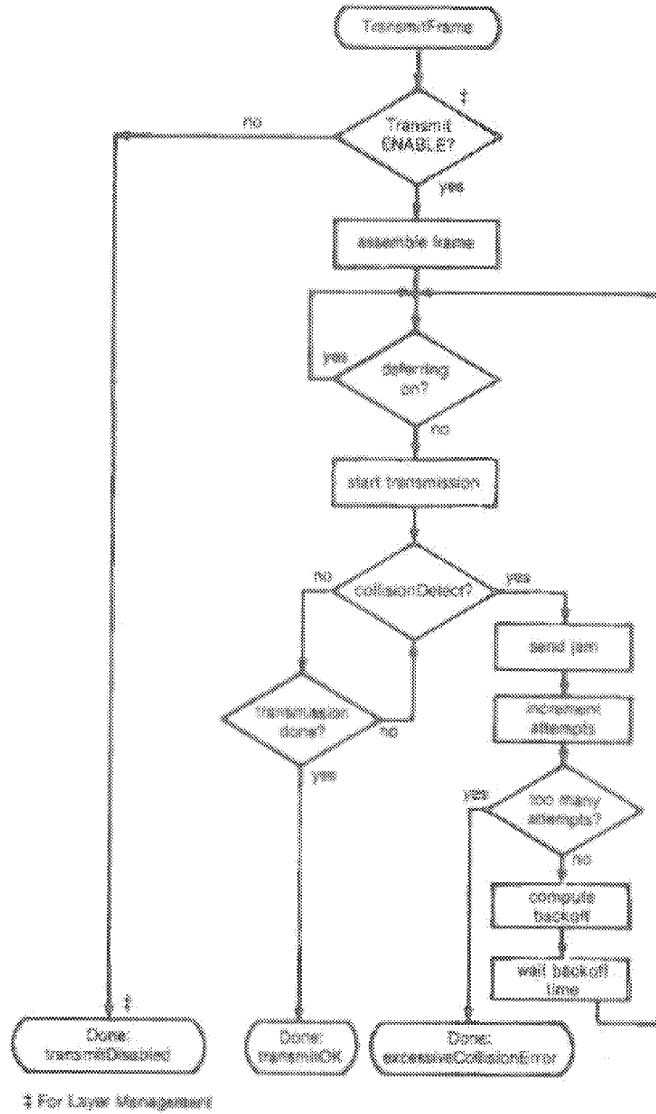

Fig 4-3
 Relationship Among CSMA/CD Procedures

Figure 4-3 depicts the static structure of the procedural model, showing how the various processes and procedures interact by invoking each other. Figures 4-4 and 4-5 summarize the dynamic behavior of the model during transmission and reception, focusing on the steps that shall be performed, rather than the procedural structure that performs them. The usage of the shared state variables is not depicted in the figures, but is described in the comments and prose in the following sections.

4.2.2.4 Layer Management Extensions to Procedural Model. In order to incorporate network management functions, this Procedural Model has been expanded beyond that in ISO/IEC 8802-3 : 1990. Network management functions have been incorporated in two ways. First, 4.2.7-4.2.10, 4.3.2, and Fig 4-4 have been modified and expanded to provide management services. Second, Layer Management procedures have been added as 5.2.4. Note that Pascal variables are shared between Sections 4 and 5. Within the Pascal descriptions provided in Section 4, a "†" in the left margin indicates a line that has been added to support management services. These lines are only required if Layer Management is being implemented.



(a) TransmitFrame

Fig 4-4
Control Flow Summary

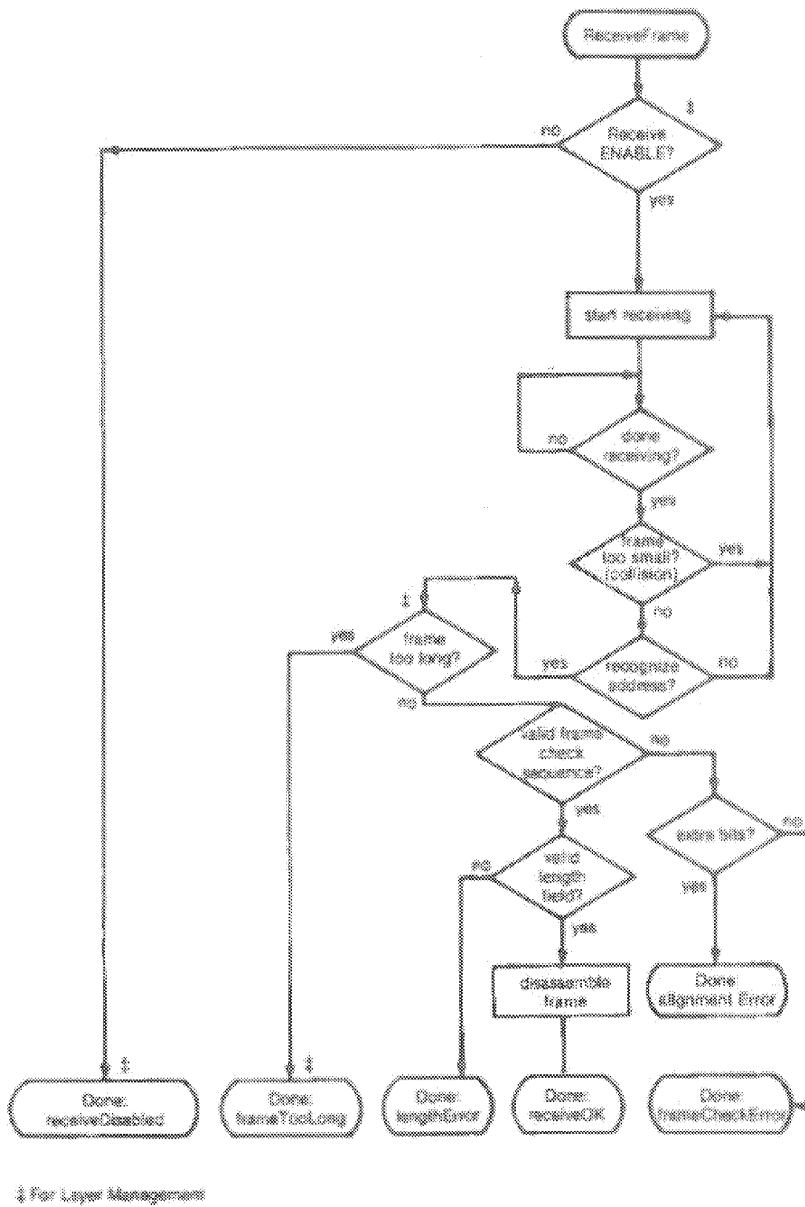

(b) ReceiveFrame

Fig 4-4
Control Flow Summary

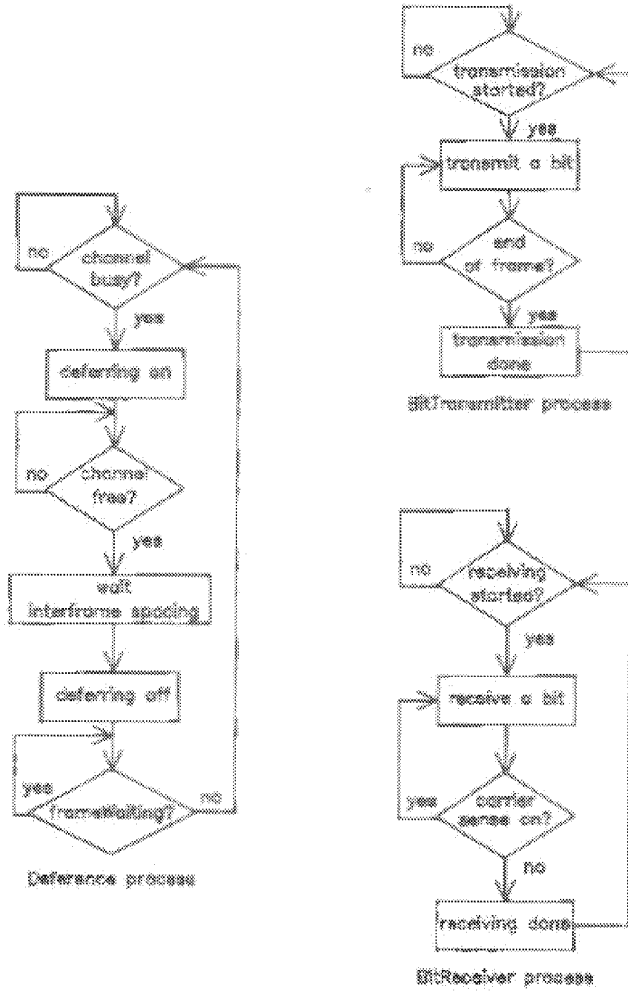

Fig 4-6
Control Flow: MAC Sublayer

These changes do not affect any aspect of the MAC behavior as observed at the LLC-MAC and MAC-PLS interfaces of ISO/IEC 8802-3 : 1990.

The Pascal procedural specification shall be consulted for the definitive statement when there is any apparent ambiguity concerning the definition of some aspect of the CSMA/CD MAC access method.

4.2.3 Frame Transmission Model. Frame transmission includes data encapsulation and Media Access management aspects:

- (1) Transmit Data Encapsulation includes the assembly of the outgoing frame (from the values provided by the LLC sublayer) and frame check sequence generation.
- (2) Transmit Media Access Management includes carrier deference, interframe spacing, collision detection and enforcement, and collision backoff and retransmission.

4.2.3.1 Transmit Data Encapsulation

4.2.3.1.1 Frame Assembly. The fields of the CSMA/CD MAC frame are set to the values provided by the LLC sublayer as arguments to the TransmitFrame operation (see 4.3) with the exception of the padding necessary to enforce the minimum framesize and the frame check sequence that is set to the CRC value generated by the MAC sublayer.

4.2.3.1.2 Frame Check Sequence Generation. The CRC value defined in 3.8 is generated and inserted in the frame check sequence field, following the fields supplied by the LLC sublayer.

4.2.3.2 Transmit Media Access Management

4.2.3.2.1 Carrier Deference. Even when it has nothing to transmit, the CSMA/CD MAC sublayer monitors the physical medium for traffic by watching the carrierSense signal provided by the PLS. Whenever the medium is busy, the CSMA/CD MAC sublayer defers to the passing frame by delaying any pending transmission of its own. After the last bit of the passing frame (that is, when carrierSense changes from true to false), the CSMA/CD MAC sublayer continues to defer for a proper interFrameSpacing (see 4.2.3.2.2).

If, at the end of the interFrameSpacing, a frame is waiting to be transmitted, transmission is initiated independent of the value of carrierSense. When transmission has completed (or immediately, if there was nothing to transmit) the CSMA/CD MAC sublayer resumes its original monitoring of carrierSense.

When a frame is submitted by the LLC sublayer for transmission, the transmission is initiated as soon as possible, but in conformance with the rules of deference stated above.

NOTE: It is possible for the PLS carrier sense indication to fail to be asserted briefly during a collision on the media. If the Deference process simply times the interFrame gap based on this indication it is possible for a short interFrame gap to be generated, leading to a potential reception failure of a subsequent frame. To enhance system robustness the following optional measures, as specified in 4.2.3, are recommended when interFrameSpacingInterI is other than zero:

- (1) Upon completing a transmission, start timing the interpacket gap as soon as transmitting and carrierSense are both false.
- (2) When timing an interFrame gap following reception, reset the interFrame gap timing if carrierSense becomes true during the first 2/3 of the interFrame gap timing interval. During the final 1/3 of the interval the timer shall not be reset to ensure fair access to the medium. An initial period shorter than 2/3 of the interval is permissible including zero.

4.2.3.2.2 Interframe Spacing. As defined in 4.2.3.2.1, the rules for deferring to passing frames ensure a minimum interframe spacing of interFrameSpacing seconds. This is intended to provide interframe recovery time for other CSMA/CD sublayers and for the physical medium.

Note that interFrameSpacing is the minimum value of the interframe spacing. If necessary for implementation reasons, a transmitting sublayer may use a larger value with a resulting decrease in its throughput. The larger value is determined by the parameters of the implementation, see 4.4.

4.2.3.2.3 Collision Handling. Once a CSMA/CD sublayer has finished deferring and has started transmission, it is still possible for it to experience contention for the medium. Collisions can occur until acquisition of the network has been accomplished through the deference of all other stations' CSMA/CD sublayers.

The dynamics of collision handling are largely determined by a single parameter called the slot time. This single parameter describes three important aspects of collision handling:

- (1) It is an upper bound on the acquisition time of the medium.
- (2) It is an upper bound on the length of a frame fragment generated by a collision.
- (3) It is the scheduling quantum for retransmission.

To fulfill all three functions, the slot time shall be larger than the sum of the Physical Layer round-trip propagation time and the Media Access Layer maximum jam time. The slot time is determined by the parameters of the implementation, see 4.4.

4.2.3.2.4 Collision Detection and Enforcement. Collisions are detected by monitoring the collisionDetect signal provided by the Physical Layer. When a collision is detected during a frame transmission, the transmission is not terminated immediately. Instead, the transmission continues until additional bits specified by jamSize have been transmitted (counting from the time collisionDetect went on). This collision enforcement or jam guarantees that the duration of the collision is sufficient to ensure its detection by all transmitting stations on the network. The content of the jam is unspecified; it may be any fixed or variable pattern convenient to the Media Access implementation, however, the implementation shall not be intentionally designed to be the 32-bit CRC value corresponding to the (partial) frame transmitted prior to the jam.

4.2.3.2.5 Collision Backoff and Retransmission. When a transmission attempt has terminated due to a collision, it is retried by the transmitting CSMA/CD sublayer until either it is successful or a maximum number of attempts (attemptLimit) have been made and all have terminated due to collisions. Note that all attempts to transmit a given frame are completed before any subsequent outgoing frames are transmitted. The scheduling of the retransmissions is determined by a controlled randomization process called "truncated binary exponential backoff." At the end of enforcing a collision (jamming), the CSMA/CD sublayer delays before attempting to retransmit the frame. The delay is an integer multiple of slotTime. The number of slot times to delay before the nth retransmission attempt is chosen as a uniformly distributed random integer r in the range:

$$0 \leq r < 2^k$$

where

$$k = \min(n, 10)$$

If all attemptLimit attempts fail, this event is reported as an error. Algorithms used to generate the integer r should be designed to minimize the correlation between the numbers generated by any two stations at any given time.

Note that the values given above define the most aggressive behavior that a station may exhibit in attempting to retransmit after a collision. In the course of implementing the retransmission scheduling procedure, a station may introduce extra delays that will degrade its own throughput, but in no case may a station's retransmission scheduling result in a lower average delay between retransmission attempts than the procedure defined above.

4.2.3.3 Minimum Frame Size. The CSMA/CD Media Access mechanism requires that a minimum frame length of minFrameSize bits be transmitted. If frameSize is less than minFrameSize, then the CSMA/CD MAC sublayer shall append extra bits in units of octets, after the end of the LLC data field but prior to calculating, and appending, the FCS. The number of extra bits shall be sufficient to ensure that the frame, from the DA field through the FCS field inclusive, is at least minFrameSize bits. The content of the pad is unspecified.

4.2.4 Frame Reception Model. CSMA/CD MAC sublayer frame reception includes both data decapsulation and Media Access management aspects:

- (1) Receive Data Decapsulation comprises address recognition, frame check sequence validation, and frame disassembly to pass the fields of the received frame to the LLC sublayer.
- (2) Receive Media Access Management comprises recognition of collision fragments from incoming frames and truncation of frames to octet boundaries.

4.2.4.1 Receive Data Decapsulation

4.2.4.1.1 Address Recognition. The CSMA/CD MAC sublayer is capable of recognizing individual and group addresses.

- (1) *Individual Addresses.* The CSMA/CD MAC sublayer recognizes and accepts any frame whose DA field contains the individual address of the station.
- (2) *Group Addresses.* The CSMA/CD MAC sublayer recognizes and accepts any frame whose DA field contains the Broadcast address.

The CSMA/CD MAC sublayer is capable of activating some number of group addresses as specified by higher layers. The CSMA/CD MAC sublayer recognizes and accepts any frame whose Destination Address field contains an active group address. An active group address may be deactivated.

4.2.4.1.2 Frame Check Sequence Validation. FCS validation is essentially identical to FCS generation. If the bits of the incoming frame (exclusive of the FCS field itself) do not generate a CRC value identical to the one received, an error has occurred and the frame is identified as invalid.

4.2.4.1.3 Frame Disassembly. Upon recognition of the Start Frame Delimiter at the end of the preamble sequence, the CSMA/CD MAC sublayer accepts the frame. If there are no errors, the frame is disassembled and the fields are passed to the LLC sublayer by way of the output parameters of the ReceiveFrame operation.

4.2.4.2 Receive Media Access Management

4.2.4.2.1 Framing. The CSMA/CD sublayer recognizes the boundaries of an incoming frame by monitoring the carrierSense signal provided by the PLS. There are two possible length errors that can occur, that indicate ill-framed data: the frame may be too long, or its length may not be an integer number of octets.

- (1) *Maximum Frame Size.* The receiving CSMA/CD sublayer is not required to enforce the frame size limit, but it is allowed to truncate frames longer than maxFrameSize octets and report this event as an (implementation-dependent) error.
- (2) *Integer Number of Octets in Frame.* Since the format of a valid frame specifies an integer number of octets, only a collision or an error can produce a frame with a length that is not an integer multiple of 8 bits. Complete frames (that is, not rejected as collision fragments; see 4.2.4.2.2) that do not contain an integer number of octets are truncated to the nearest octet boundary. If frame check sequence validation detects an error in such a frame, the status code alignmentError is reported.

4.2.4.2.2 Collision Filtering. The smallest valid frame shall be at least one slotTime in length. This determines the minFrameSize. Any frame containing less than minFrameSize bits is presumed to be a fragment resulting from a collision. Since occasional collisions are a normal part of the Media Access management procedure, the discarding of such a fragment is not reported as an error to the LLC sublayer.

4.2.5 Preamble Generation. In a LAN implementation, most of the Physical Layer components are allowed to provide valid output some number of bit times after being presented valid input signals. Thus it is necessary for a preamble to be sent before the start of data, to allow the PLS circuitry to reach its steady-state. Upon request by TransmitLinkMgmt to transmit the first bit of a new frame, PhysicalSignalEncap shall first transmit the preamble, a bit sequence used for physical medium stabilization and synchronization, followed by the Start Frame Delimiter. If, while transmitting the preamble, the PLS asserts the collision detect signal, any remaining preamble bits shall be sent. The preamble pattern is:

10101010 10101010 10101010 10101010 10101010 10101010 10101010

The bits are transmitted in order, from left to right. The nature of the pattern is such that, for Manchester encoding, it appears as a periodic waveform on the medium that enables bit synchronization. It should be noted that the preamble ends with a "0."

4.2.6 Start Frame Sequence. The PLS recognizes the presence of activity on the medium through the carrier sense signal. This is the first indication that the frame reception process should begin. Upon reception of the sequence 10101011 immediately following a latter part of the preamble pattern, PhysicalSignal-Decap shall begin passing successive bits to ReceiveLinkMgmt for passing to the LLC sublayer.

4.2.7 Global Declarations. This section provides detailed formal specifications for the CSMA/CD MAC sublayer. It is a specification of generic features and parameters to be used in systems implementing this media access method. Subsection 4.4 provides values for these sets of parameters for recommended implementations of this media access mechanism.

4.2.7.1 Common Constants and Types. The following declarations of constants and types are used by the frame transmission and reception sections of each CSMA/CD sublayer:

```

const
  addressSize = ... ; (16 or 48 bits in compliance with 3.2.3)
  lengthSize = 16; (in bits)
  LLCdataSize = ... ; (LLC Data, see 4.2.2.2, (1)(c))
  padSize = ... ; (in bits, = max (0, minFrameSize - (2 × addressSize + lengthSize + LLCdataSize +
    crcSize))).
  dataSize = ... ; (= LLCdataSize + padSize)
  crcSize = 32; (32 bit CRC = 4 octets)
  frameSize = ... ; (= 2 × addressSize + lengthSize + dataSize + crcSize, see 4.2.2.2(1))
  minFrameSize = ... ; (in bits, implementation-dependent, see 4.4)
  slotTime = ... ; (unit of time for collision handling, implementation-dependent, see 4.4)
  preambleSize = ... ; (in bits, physical-medium-dependent)
  sfdSize = 8; (8 bit start frame delimiter)
  headerSize = ... ; (sum of preambleSize and sfdSize)

type
  Bit = 0..1;
  AddressValue = array [1..addressSize] of Bit;
  LengthValue = array [1..lengthSize] of Bit;
  DataValue = array [1..dataSize] of Bit;
  CRCValue = array [1..crcSize] of Bit;
  PreambleValue = array [1..preambleSize] of Bit;
  SfdValue = array [1..sfdSize] of Bit;
  ViewPoint = (fields, bits); (Two ways to view the contents of a frame)
  HeaderViewPoint = (headerFields, headerBits);
  Frame = record (Format of Media Access frame)
    case view: ViewPoint of
      fields: (
        destinationField: AddressValue;
        sourceField: AddressValue;
        lengthField: LengthValue;
        dataField: DataValue;
        crcField: CRCValue);
      bits: (contents: array [1..frameSize] of Bit)
    end; (Frame)
  Header = record (Format of preamble and start frame delimiter)
    case headerView: HeaderViewPoint of
      headerFields: (
        preamble: PreambleValue;
        sfd: SfdValue);
      headerBits: (
        headerContents: array [1..headerSize] of Bit)
    end; (defines header for MAC frame)

```

4.2.7.2 Transmit State Variables. The following items are specific to frame transmission. (See also 4.4.)

```

const
  interFrameSpacing = ... ; (minimum time between frames)
  interFrameSpacingPart1 = ... ; (duration of first portion of interFrame timing. In range 0 up to 2/3
    interFrameSpacing)
  interFrameSpacingPart2 = ... ; (duration of remainder of interFrame timing. Equal to
    interFrameSpacing - interFrameSpacingPart1)
  attemptLimit = ... ; (Max number of times to attempt transmission)
  backOffLimit = ... ; (Limit on number of times to back off)
  jamSize = ... ; (in bits: the value depends upon medium and collision detect implementation)

var
  outgoingFrame: Frame; (The frame to be transmitted)
  outgoingHeader: Header;
  currentTransmitBit, lastTransmitBit: 1..frameSize;
  (Positions of current and last outgoing bits in outgoingFrame)
  lastHeaderBit: 1..headerSize;
  deferring: Boolean; (Implies any pending transmission must wait for the medium to clear)
  frameWaiting: Boolean; (Indicates that outgoingFrame is deferring)
  attempts: 0..attemptLimit; (Number of transmission attempts on outgoingFrame)
  newCollision: Boolean; (Indicates that a collision has occurred but has not yet been jammed)
  transmitSucceeding: Boolean; (Running indicator of whether transmission is succeeding)

```

4.2.7.3 Receive State Variables. The following items are specific to frame reception. (See also 4.4.)

```

var
  incomingFrame: Frame; (The frame being received)
  currentReceiveBit: 1..frameSize; (Position of current bit in incomingFrame)
  receiving: Boolean; (Indicates that a frame reception is in progress)
  excessBits: 0..7; (Count of excess trailing bits beyond octet boundary)
  receiveSucceeding: Boolean; (Running indicator of whether reception is succeeding)
  validLength: Boolean; (Indicator of whether received frame has a length error)
  exceedsMaxLength: Boolean; (Indicator of whether received frame has a length longer than the
    maximum permitted length)

```

4.2.7.4 Summary of Interlayer Interfaces

- (1) The interface to the LLC sublayer, defined in 4.3.2, is summarized below:

```

type
  ‡ TransmitStatus = (transmitDisabled, transmitOK, excessiveCollisionError);
    (Result of TransmitFrame operation)
  ‡ ReceiveStatus = (receiveDisabled, receiveOK, frameTooLong, frameCheckError, lengthError,
    alignmentError); (Result of ReceiveFrame operation)

function TransmitFrame (
  destinationParam: AddressValue;
  sourceParam: AddressValue;
  lengthParam: LengthValue;
  dataParam: DataValue): TransmitStatus; (Transmits one frame)

function ReceiveFrame (
  var destinationParam: AddressValue;
  var sourceParam: AddressValue;
  var lengthParam: LengthValue;

```

```
var dataParam: DataValue; ReceiveStatus; (Receives one frame)
```

- (2) The interface to the Physical Layer, defined in 4.3.3, is summarized below:

```
var
  carrierSense: Boolean; (Indicates incoming bits)
  transmitting: Boolean; (Indicates outgoing bits)
  wasTransmitting: Boolean; (Indicates transmission in progress or just completed)
  collisionDetect: Boolean; (Indicates medium contention)
  procedure TransmitBit (bitParam: Bit); (Transmits one bit)
  function ReceiveBit: Bit; (Receives one bit)
  procedure Wait (bitTimes: integer); (Waits for indicated number of bit-times)
```

4.2.7.5 State Variable Initialization. The procedure Initialize must be run when the MAC sublayer begins operation, before any of the processes begin execution. Initialize sets certain crucial shared state variables to their initial values. (All other global variables are appropriately reinitialized before each use.) Initialize then waits for the medium to be idle, and starts operation of the various processes.

If Layer Management is implemented, the Initialize procedure shall only be called as the result of the initializeMAC action (5.2.2.2.1).

```
procedure Initialize;
begin
  frameWaiting := false;
  deferring := false;
  newCollision := false;
  transmitting := false; (In interface to Physical Layer; see below)
  receiving := false;
  while carrierSense do nothing;
  (Start execution of all processes)
end; (Initialize)
```

4.2.8 Frame Transmission. The algorithms in this section define MAC sublayer frame transmission. The function TransmitFrame implements the frame transmission operation provided to the LLC sublayer:

```
function TransmitFrame (
  destinationParam: AddressValue;
  sourceParam: AddressValue;
  lengthParam: LengthValue;
  dataParam: DataValue): TransmitStatus;
  procedure TransmitDataEncap; ... (nested procedure; see body below)
begin
  if transmitEnabled then
  begin
    TransmitDataEncap;
    TransmitFrame := TransmitLinkMgmt;
  end
  else TransmitFrame := transmitDisabled
end; (TransmitFrame)
```

If transmission is enabled, TransmitFrame calls the internal procedure TransmitDataEncap to construct the frame. Next, TransmitLinkMgmt is called to perform the actual transmission. The TransmitStatus returned indicates the success or failure of the transmission attempt.

TransmitDataEncap builds the frame and places the 32-bit CRC in the frame check sequence field:

```
procedure TransmitDataEncap;
begin
  with outgoingFrame do
```

```

begin (assemble frame)
  view := fields;
  destinationField := destinationParam;
  sourceField := sourceParam;
  lengthField := lengthParam;
  dataField := ComputePad (lengthParam, dataParam);
  fcsField := CRC32(outgoingFrame);
  view := bits
end (assemble frame)
with outgoingHeader do
  begin
    headerView := headerFields;
    preamble := ...; (* '1010...10,' LSB to MSB*)
    sfd := ...; (* '10101011,' LSB to MSB*)
    headerView := headerBits
  end
end; (TransmitDataEncap)

```

ComputePad appends an array of arbitrary bits to the LLCdataField to pad the frame to the minimum frame size.

```

function ComputePad(
  var lengthParam:LengthValue
  var dataParam:DataValue) :DataValue;
begin
  ComputePad := (Append an array of size padSize of arbitrary bits to the LLCdataField)
end; (ComputePadParam)

```

TransmitLinkMgmt attempts to transmit the frame, deferring first to any passing traffic. If a collision occurs, transmission is terminated properly and retransmission is scheduled following a suitable backoff interval:

```

function TransmitLinkMgmt: TransmitStatus;
begin
  attempts := 0; transmitSucceeding := false;
  lateCollisionCount := 0;
  deferred := false; initialize;
  excessDefer := false;
  while(attempts < attemptLimit) and (not transmitSucceeding)do
  begin (loop)
    if attempts > 0 then BackOff;
    frameWaiting := true;
    lateCollisionError := false;
    † while deferring do (defer to passing frame, if any)
      begin
        † nothing;
        deferred := true;
      end;
    frameWaiting := false;
    StartTransmit;
    while transmitting do WatchForCollision;
    if lateCollisionError then lateCollisionCount := lateCollisionCount + 1;
    attempts := attempts+1
  end; (loop)
  if transmitSucceeding then TransmitLinkMgmt := transmitOK
  else TransmitLinkMgmt := excessiveCollisionError;
  LayerMgmt/TransmitCounters; (update transmit and transmit error counters in 5.3.4.2)
end; (TransmitLinkMgmt)

```

Each time a frame transmission attempt is initiated, StartTransmit is called to alert the BitTransmitter process that bit transmission should begin:

```

procedure StartTransmit;
begin
  currentTransmitBit := 1;
  lastTransmitBit := frameSize;
  transmitSucceeding := true;
  transmitting := true;
  lastHeaderBit := headerSize;
end; (StartTransmit)

```

Once frame transmission has been initiated, TransmitLinkMgmt monitors the medium for contention by repeatedly calling WatchForCollision:

```

procedure WatchForCollision;
begin
  if transmitSucceeding and collisionDetect then
    begin
      if currentTransmitBit > (minFrameSize - headerSize) then
        lateCollisionError := true;
      newCollision := true;
      transmitSucceeding := false;
    end
end; (WatchForCollision)

```

WatchForCollision, upon detecting a collision, updates newCollision to ensure proper jamming by the BitTransmitter process. The current transmit bit number is checked to see if this is a late collision. If the collision occurs later than a collision window of 312 bit times into the packet, it is considered as evidence of a late collision. The point at which the collision is received is determined by the network media propagation time and the delay time through a station and, as such, is implementation-dependent (see 4.1.2.2). An implementation may optionally elect to end retransmission attempts after a late collision is detected.

After transmission of the jam has been completed, if TransmitLinkMgmt determines that another attempt should be made, BackOff is called to schedule the next attempt to retransmit the frame.

```

var maxBackOff 2..1024; (Working variable of BackOff)
procedure BackOff;
begin
  if attempts = 1 then maxBackOff := 2
  else if attempts ≤ backOffLimit
  then maxBackOff := maxBackOff / 2;
  Wait(slotTime × Random(0, maxBackOff))
end; (BackOff)

function Random (low, high: integer): integer;
begin
  Random := ... (uniformly distributed random integer r such that low ≤ r < high)
end; (Random)

```

BackOff performs the truncated binary exponential backoff computation and then waits for the selected multiple of the slot time.

The Deferring process runs asynchronously to continuously compute the proper value for the variable deferring.

```

process Deferring;
begin
  cycle (main loop)
end;

```

```

while not carrierSense do nothing; {watch for carrier to appear}
deferring := true; {delay start of new transmissions}
wasTransmitting := transmitting;
while carrierSense or transmitting then
  wasTransmitting := wasTransmitting or transmitting;
  if wasTransmitting do
    begin
      StartRealTimeDelay; {time out first part interframe gap}
      while RealTimeDelay(interFrameSpacingPart1) do nothing
    end
  else
    begin
      StartRealTimeDelay;
      repeat
        while carrierSense do StartRealTimeDelay
      until not RealTimeDelay(interFrameSpacingPart1)
    end;
    StartRealTimeDelay; {time out second part interframe gap}
    while RealTimeDelay(interFrameSpacingPart2) do nothing;
    deferring := false; {allow new transmissions to proceed}
    while frameWaiting do nothing; {allow waiting transmission if any}
  end {main loop}
end; {Deference}

```

```

procedure StartRealTimeDelay

```

```

begin
  {reset the realtime timer and start it timing}
end; {StartRealTimeDelay}

```

```

function RealTimeDelay (µsec:real): Boolean;

```

```

begin
  {return the value true if the specified number of microseconds have
  not elapsed since the most recent invocation of StartRealTimeDelay,
  otherwise return the value false}
end; {RealTimeDelay}

```

The BitTransmitter process runs asynchronously, transmitting bits at a rate determined by the Physical Layer's TransmitBit operation:

```

process BitTransmitter;

```

```

begin
  cycle {outer loop}
  if transmitting then
    begin {inner loop}
      PhysicalSignalEncap; {Send preamble and start of frame delimiter}
      while transmitting do
        begin
          TransmitBit(outgoingFrame[currentTransmitBit]); {send next bit to Physical Layer}
          if newCollision then StartJam else NextBit
        end;
      end; {inner loop}
    end; {outer loop}
end; {BitTransmitter}

```

```

procedure PhysicalSignalEncap;

```

```

begin
  while currentTransmitBit ≤ lastHeaderBit do
    begin

```



```

    TransmitBit(outgoingHeader[currentTransmitBit]); (transmit header one bit at a time)
    currentTransmitBit := currentTransmitBit + 1;
  end
  if newCollision then StartJam else
    currentTransmitBit := 1
  end; (PhysicalSignalEncap)

  procedure NextBit;
  begin
    currentTransmitBit := currentTransmitBit + 1;
    transmitting := (currentTransmitBit ≤ lastTransmitBit)
  end; (NextBit)

  procedure StartJam;
  begin
    currentTransmitBit := 1;
    lastTransmitBit := jamSize;
    newCollision := false
  end; (StartJam)

```

BitTransmitter, upon detecting a new collision, immediately enforces it by calling startJam to initiate the transmission of the jam. The jam should contain a sufficient number of bits of arbitrary data so that it is assured that both communicating stations detect the collision. (StartJam uses the first set of bits of the frame up to jamSize, merely to simplify this program.)

4.2.9 Frame Reception. The algorithms in this section define CSMA/CD Media Access sublayer frame reception.

The procedure ReceiveFrame implements the frame reception operation provided to the LLC sublayer:

```

  function ReceiveFrame (
    var destinationParam: AddressValue;
    var sourceParam: AddressValue;
    var lengthParam: LengthValue;
    var dataParam: DataValue): ReceiveStatus;
    function ReceiveDataDecap: ReceiveStatus; ... (nested function; see body below)
  begin
    if receiveEnabled then
      repeat
        ReceiveLinkMgmt;
        ReceiveFrame := ReceiveDataDecap;
      until receiveSucceeding
    else
      ReceiveFrame := receiveDisabled
    ; (ReceiveFrame)

```

If enabled, ReceiveFrame calls ReceiveLinkMgmt to receive the next valid frame, and then calls the internal procedure ReceiveDataDecap to return the frame's fields to the LLC sublayer if the frame's address indicates that it should do so. The returned ReceiveStatus indicates the presence or absence of detected transmission errors in the frame.

```

  function ReceiveDataDecap: ReceiveStatus;
  ‡   var status: ReceiveStatus; (holds receive status information)
  begin
  ‡   with incomingFrame do
  ‡     begin
  ‡       view := fields;
  ‡       receiveSucceeding := RecognizeAddress (incomingFrame, destinationField);

```

```

receiveSucceeding := LayerMgmtRecognizeAddress (destinationField);
‡ if receiveSucceeding then
begin (disassemble frame)
  destinationParam := destinationField;
  sourceParam := sourceField;
  lengthParam := lengthField;
  dataParam := RemovePad (lengthField, dataField);
  exceedsMaxLength := ...; (check to determine if receive frame size exceeds the maximum
  permitted frame size (maxFrameSize))
  if exceedsMaxLength then status := frameTooLong;
  else
  if fcsField = CRC32 (incomingFrame) then
  begin
‡ if validLength then status := receiveOK
‡ else status := lengthError
  end
  else
  begin
‡ if excessBits = 0 then status := frameCheckError
‡ else status := alignmentError;
  end;
  LayerMgmtReceiveCounters(status);
  (update receive and receive error counters in 5.2.4.3)
  view := bits
  end (disassemble frame)
‡ end (with incomingFrame)
‡ ReceiveDataDecap := status;
end; (ReceiveDataDecap)

function RecognizeAddress (address: AddressValue): Boolean;
begin
  RecognizeAddress := ... (Returns true for the set of physical, broadcast, and multicast-group
  addresses corresponding to this station)
end; (RecognizeAddress)

function RemovePad(
  var lengthParam:LengthValue
  var dataParam:DataValue):DataValue;
begin
  validLength := (Check to determine if value represented by lengthParam matches received
  LLCdataSize);
  if validLength then
    RemovePad := (truncate the dataParam (when present) to value represented by lengthParam
    (in octets) and return the result)
  else
    RemovePad := dataParam
end; (RemovePad)

```

ReceiveLinkMgmt attempts repeatedly to receive the bits of a frame, discarding any fragments from collisions by comparing them to the minimum valid frame size:

```

procedure ReceiveLinkMgmt;
begin
  repeat
    StartReceive;
    while receiving do nothing; (wait for frame to finish arriving)
    excessBits := frameSize mod 8;
  until ...
end;

```

```

    frameSize := frameSize - excessBits; {truncate to octet boundary}
    receiveSucceeding := (frameSize ≥ minFrameSize); {reject collision fragments}
  until receiveSucceeding
end; {ReceiveLinkMgmt}

procedure StartReceive;
begin
  currentReceiveBit := 1;
  receiving := true
end; {StartReceive}

```

The BitReceiver process runs asynchronously, receiving bits from the medium at the rate determined by the Physical Layer's ReceiveBit operation:

```

process BitReceiver;
  var b: Bit;
begin
  cycle {outer loop}
  while receiving do
  begin {inner loop}
    if currentReceiveBit = 1 then
      PhysicalSignalDecap; {Strip off the preamble and start frame delimiter}
      b := ReceiveBit; {Get next bit from physical Media Access}
      if carrierSense then
        begin {append bit to frame}
          incomingFrame[currentReceiveBit] := b;
          currentReceiveBit := currentReceiveBit + 1;
        end; {append bit to frame}
        receiving := carrierSense
      end {inner loop}
      frameSize := currentReceiveBit - 1
    end {outer loop}
  end; {BitReceiver}

procedure PhysicalSignalDecap;
begin
  {Receive one bit at a time from physical medium until a valid sfd is detected, discard bits, and return}
end; {PhysicalSignalDecap}

```

4.2.10 Common Procedures. The function CRC32 is used by both the transmit and receive algorithms to generate a 32 bit CRC value:

```

function CRC32 (f: Frame): CRCValue;
begin
  CRC32 := [The 32-bit CRC ]
end; {CRC32}

```

Purely to enhance readability, the following procedure is also defined:

```

procedure nothing; begin end;

```

The idle state of a process (that is, while waiting for some event) is cast as repeated calls on this procedure.

4.3 Interfaces to/from Adjacent Layers

4.3.1 Overview. The purpose of this section is to provide precise definitions of the interfaces between the architectural layers defined in Section 1 in compliance with the Media Access Service Specification given in Section 2. In addition, the services required from the physical medium are defined.

The notation used here is the Pascal language, in keeping with the procedural nature of the precise MAC sublayer specification (see 4.2). Each interface is described as a set of procedures or shared variables, or both, that collectively provide the only valid interactions between layers. The accompanying text describes the meaning of each procedure or variable and points out any implicit interactions among them.

Note that the description of the interfaces in Pascal is a notational technique, and in no way implies that they can or should be implemented in software. This point is discussed more fully in 4.2, that provides complete Pascal declarations for the data types used in the remainder of this section. Note also that the "synchronous" (one frame at a time) nature of the frame transmission and reception operations is a property of the architectural interface between the LLC and MAC sublayers, and need not be reflected in the implementation interface between a station and its sublayer.

4.3.2 Services Provided by the MAC Sublayer. The services provided to the LLC sublayer by the MAC sublayer are transmission and reception of LLC frames. The interface through which the LLC sublayer uses the facilities of the MAC sublayer therefore consists of a pair of functions.

Functions:

TransmitFrame
ReceiveFrame

Each of these functions has the components of a LLC frame as its parameters (input or output), and returns a status code as its result. Note that the *service_class* defined in 2.3.1 is ignored by CSMA/CD MAC.

The LLC sublayer transmits a frame by invoking *TransmitFrame*:

```
function TransmitFrame (  
    destinationParam: AddressValue;  
    sourceParam: AddressValue;  
    lengthParam: LengthValue;  
    dataParam: DataValue): TransmitStatus;
```

The *TransmitFrame* operation is synchronous. Its duration is the entire attempt to transmit the frame; when the operation completes, transmission has either succeeded or failed, as indicated by the resulting status code:

```
type TransmitStatus = (transmitOK, excessiveCollisionError);  
‡ type TransmitStatus = (transmitDisabled, transmitOK, excessiveCollisionError);
```

The *transmitDisabled* status code indicates that the transmitter is not enabled. Successful transmission is indicated by the status code *transmitOK*; the code *excessiveCollisionError* indicates that the transmission attempt was aborted due to the excessive collisions, because of heavy traffic or a network failure.

The LLC sublayer accepts incoming frames by invoking *ReceiveFrame*:

```
function ReceiveFrame (  
    var destinationParam: AddressValue;  
    var sourceParam: AddressValue;  
    var lengthParam: LengthValue;  
    var dataParam: DataValue): ReceiveStatus;
```

The *ReceiveFrame* operation is synchronous. The operation does not complete until a frame has been received. The fields of the frame are delivered via the output parameters with a status code:

```
type ReceiveStatus = (receiveOK, lengthError, frameCheckError, alignmentError);
```

‡ type Receive Status = (receiveDisabled, receive OK, frameTooLong, frameCheckError, lengthError, alignmentError);

The receiveDisabled status indicates that the receiver is not enabled. Successful reception is indicated by the status code receiveOK. The frameTooLong error indicates that a frame was received whose frameSize was beyond the maximum allowable frame size. The code frameCheckError indicates that the frame received was damaged by a transmission error. The lengthError indicates the lengthParam value was inconsistent with the frameSize of the received frame. The code alignmentError indicates that the frame received was damaged, and that in addition, its length was not an integer number of octets.

4.3.3 Services Required from the Physical Layer. The interface through which the CSMA/CD MAC sublayer uses the facilities of the Physical Layer consists of a function, a pair of procedures and three Boolean variables.

<i>Function:</i>	<i>Procedures:</i>	<i>Variables:</i>
ReceiveBit	TransmitBit Wait	collisionDetect carrierSense transmitting

During transmission, the contents of an outgoing frame are passed from the MAC sublayer to the Physical Layer by way of repeated use of the TransmitBit operation:

procedure TransmitBit (bitParam: Bit);

Each invocation of TransmitBit passes one new bit of the outgoing frame to the Physical Layer. The TransmitBit operation is synchronous. The duration of the operation is the entire transmission of the bit. The operation completes, when the Physical Layer is ready to accept the next bit and it transfers control to the MAC sublayer.

The overall event of data being transmitted is signaled to the Physical Layer by way of the variable transmitting:

var transmitting: Boolean;

Before sending the first bit of a frame, the MAC sublayer sets transmitting to true, to inform the Physical Media Access that a stream of bits will be presented via the TransmitBit operation. After the last bit of the frame has been presented, the MAC sublayer sets transmitting to false to indicate the end of the frame.

The presence of a collision in the physical medium is signaled to the MAC sublayer by the variable collisionDetect:

var collisionDetect: Boolean;

The collisionDetect signal remains true during the duration of the collision.

NOTE: Since an entire collision may occur during preamble generation, the MAC sublayer shall handle this possibility by monitoring collisionDetect concurrently with its transmission of outgoing bits. See 4.2 for details.

The collisionDetect signal is generated only during transmission and is never true at any other time; in particular, it cannot be used during frame reception to detect collisions between overlapping transmissions from two or more other stations.

During reception, the contents of an incoming frame are retrieved from the Physical Layer by the MAC sublayer via repeated use of the ReceiveBit operation:

function ReceiveBit: Bit;

Each invocation of ReceiveBit retrieves one new bit of the incoming frame from the Physical Layer. The ReceiveBit operation is synchronous. Its duration is the entire reception of a single bit. Upon receiving a bit, the MAC sublayer shall immediately request the next bit until all bits of the frame have been received. (See 4.2 for details.)

The overall event of data being received is signaled to the MAC sublayer by the variable *carrierSense*:

var carrierSense: Boolean;

When the Physical Layer sets *carrierSense* to true, the MAC sublayer shall immediately begin retrieving the incoming bits by the *ReceiveBit* operation. When *carrierSense* subsequently becomes false, the MAC sublayer can begin processing the received bits as a completed frame. Note that the true/false transitions of *carrierSense* are not defined to be precisely synchronized with the beginning and end of the frame, but may precede the beginning and lag the end, respectively. If an invocation of *ReceiveBit* is pending when *carrierSense* becomes false, *ReceiveBit* returns an undefined value, which should be discarded by the MAC sublayer. (See 4.2 for details.)

The MAC sublayer shall also monitor the value of *carrierSense* to defer its own transmissions when the medium is busy.

The Physical Layer also provides the procedure *Wait*:

procedure Wait (*bitTimes*: integer);

This procedure waits for the specified number of bit times. This allows the MAC sublayer to measure time intervals in units of the (physical-medium-dependent) bit time.

Another important property of the Physical Layer, which is an implicit part of the interface presented to the MAC sublayer, is the round-trip propagation time of the physical medium. Its value represents the maximum time required for a signal to propagate from one end of the network to the other, and for a collision to propagate back. The round-trip propagation time is primarily (but not entirely) a function of the physical size of the network. The round-trip propagation time of the Physical Layer is defined in 4.4 for a selection of physical media.

4.4 Specific Implementations

4.4.1 Compatibility Overview. To provide total compatibility at all levels of the standard, it is required that each network component implementing the CSMA/CD MAC sublayer procedure adheres rigidly to these specifications. The information provided in 4.4.2.1 below provides design parameters for a specific implementation of this access method. Variations from these values result in a system implementation that violates the standard.

4.4.2 Allowable Implementations

4.4.2.1 Parameterized Values. The following table identifies the parameter values that shall be used in the 10 Mb/s implementation of a CSMA/CD MAC procedure. The primary assumptions are that the physical medium is a baseband coaxial cable with properties given in the Physical Layer section(s) of this standard.

<u>Parameters</u>	<u>Values</u>
slotTime	512 bit times
interFrameGap	9.6 μ s
attemptLimit	16
backoffLimit	10
jamSize	32 bits
maxFrameSize	1518 octets
minFrameSize	512 bits (64 octets)
addressSize	48 bits

WARNING: Any deviation from the above plans specified for a 10 Mb/s system may affect proper operation of the LAN.

See also DTE Deference Delay in 12.9.2.

4.4.2.2 Parameterized Values. The following parameter values shall be used for 1BASE5 implementations:

<u>Parameters</u>	<u>Values</u>
slotTime	512 bit times
interFrameGap	96 μ s
attemptLimit	16
backoffLimit	10
jamSize	32 bits
maxFrameSize	1518 octets
minFrameSize	512 bits (64 octets)
addressSize	48 bits

See also DTE Deference Delay in 12.9.2.

WARNING: Any deviation from the above specified values may affect proper operation of the network.



5. Layer Management

5.1 Introduction. This section provides the Layer Management specification for networks based on the CSMA/CD access method. It defines facilities comprised of a set of statistics and actions needed to provide Layer Management services. The information in this chapter should be used in conjunction with the Procedural Model defined in 4.2.7–4.2.10. The Procedural Model provides a formal description of the relationship between the CSMA/CD Layer Entities and the Layer Management facilities.

This Layer Management specification has been developed in accordance with the OSI management architecture as specified in the ISO Management Framework document, ISO/IEC 7498-4:1989 [20]. It is independent of any particular management application or management protocol.

The management facilities defined in this standard may be accessed both locally and remotely. Thus, the Layer Management specification provides facilities that can be accessed from within a station or can be accessed remotely by means of a peer management protocol operating between application entities.

In CSMA/CD no peer management facilities are necessary for initiating or terminating normal protocol operations or for handling abnormal protocol conditions. The monitoring of these activities is done by the carrier sense and collision detection mechanisms. Since these activities are necessary for normal operation of the protocol, they are not considered to be a function of Layer Management and are therefore not discussed in this section.

At this time, this standard does not include management facilities that address the unique features of repeaters or of 10BROAD36 broadband MAUs.

5.1.1 Systems Management Overview. Within the ISO Open Systems Interconnection (OSI) architecture, the need to handle the special problems of initializing, terminating, and monitoring on-going activities and assisting in their harmonious operations, as well as handling abnormal conditions, is recognized. These needs are collectively addressed by the systems management component of the OSI architecture.

The systems management component may conceptually be subdivided into a System Management Application Entity (SMAE) and Layer Management Entities (LMEs). In addition, a Management Protocol is required for the exchange of information between systems on a network. This Layer Management standard is independent of any particular Management Protocol.

The SMAE is concerned with the management of resources and their status across all layers of the OSI architecture. The System Management Application facilities have been grouped into five entities: Configuration, Fault, Performance, Security, and Accounting.

Configuration and Name Management is concerned with the initialization, normal operation, and close-down of communication facilities. It is also concerned with the naming of these resources and their interrelationship as part of a communication system. Fault Management is concerned with detection, isolation, and correction of abnormal operations. Performance Management is concerned with evaluating the behavior and the effectiveness of the communication activities. Security Management is concerned with monitoring the integrity and controlling access to the communication facilities. Accounting Management is concerned with enabling charges to be established and cost to be assigned and providing information on tariffs for the use of communication resources.

This Layer Management standard, in conjunction with the Layer Management standards of other layers, provides the means for the SMAE to perform its various functions. Layer Management collects information needed by the SMAE from the MAC and Physical Layers. It also provides a means for the SMAE to exercise control over those layers. This Layer Management standard is independent of any specific SMAE.

The SMAE has a conceptual interface to an LME concerned with the actual monitoring and control of a specific layer. The LME interfaces directly only with the SMAE, to whom it provides Layer Management facilities.

Strictly, only those management activities that imply actual exchanges of information between peer entities are pertinent to OSI architecture. Therefore, only the protocols needed to conduct such exchanges are candidates for standardization. As a practical matter, however, the specification of the Layer Management facilities provided across the conceptual Layer Management Interface (LMI) between the LME and SMAE is required. Standardization of these facilities will make practical the use of higher layer protocols for the control and maintenance of LANs.

There are two interfaces that relate the various management entities. These are as follows:

- (1) The conceptual Layer Management Interface between the SMAE and LME.
- (2) The normal layer service interface for peer-to-peer communication.

The relationship between the various management entities and the layer entities according to the ISO Model is shown in Fig 5-1.

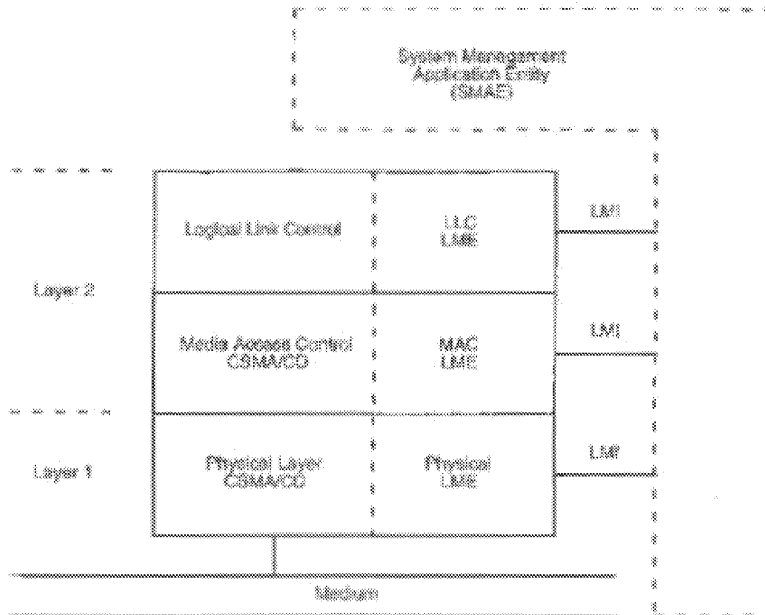

Fig 5-1
Relationship Between the Various Management Entities
and Layer Entities According to the ISO Open Systems Interconnection
(OSI) Reference Model

The conceptual LMI between the SMAE and the LME will be described in this standard in terms of the Layer Management facilities provided. It is particularly important that these facilities be defined because they may be indirectly requested on behalf of a remote SMAE. The use of this specification by other management mechanisms is not precluded.

5.1.2 Layer Management Model. The Layer Management facilities provided by the CSMA/CD MAC and Physical Layer LMEs, using the conceptual LMI, enable the SMAE to manipulate management counters and initiate actions within the layers. The LMI provides a means to monitor and control the facilities of the LMEs.

The CSMA/CD MAC/Physical Layer LMEs, in order to support the above facilities, offer a set of statistics and actions that constitute the conceptual LMI. The client of the LME (i.e., the SMAE) is thus able to read these statistics and to execute actions.

It is by executing these actions that the SMAE can cause certain desired effects on the MAC or Physical Layer Entities. The precise semantics of the relationship between the CSMA/CD Layer Entities and the Layer Management facilities are defined in 4.2.7-4.2.10 and in 5.2.4.

5.2 Management Facilities

5.2.1 Introduction. This section of the standard defines the Layer Management facilities for the IEEE 802.3 CSMA/CD MAC and Physical Layers. The intent of this standard is to furnish a management specification that can be used by the wide variety of different devices that may be attached to a network specified by ISO/IEC 8802-3. Thus, a comprehensive list of management facilities is provided.

The improper use of some of the facilities described in this section may cause serious disruption of the network. It should be noted that access to these facilities can only be obtained by means of the SMAE. To avoid duplication by each LME, and in accordance with ISO management architecture, any necessary security provisions should be provided by the SMAE. This can be in the form of specific SMAE security features or in the form of security features provided by the peer-to-peer communication facilities used by the SMAE.

The statistics and actions are categorized into the three classifications defined as follows:

Mandatory—Shall be implemented.

Recommended—Should be implemented if possible.

Optional—May be implemented.

All counters defined in this specification are wraparound counters. Wraparound counters are those that automatically go from their maximum value (or final value) to zero and continue to operate. These unsigned counters do not provide for any explicit means to return them to their minimum (zero), i.e., reset. Because of their nature, wraparound counters should be read frequently enough to avoid loss of information.

5.2.2 MAC Sublayer Management Facilities. This section of the standard defines the Layer Management facilities specific to the MAC sublayer.

5.2.2.1 MAC Statistics. The statistics defined in this section are implemented by means of counters.

In the following definitions, the term "Read only" specifies that the object cannot be written to by the client of the LME.

Frame fragments are not included in any of the statistics in this section unless otherwise stated.

The Layer Management Model in 5.2.4 and the Pascal Procedural Model in 4.2.7–4.2.10 defines the semantics of these statistics in terms of the behavior of the MAC sublayer.

5.2.2.1.1 MAC Transmit Statistics Descriptions

- (1) Number of framesTransmittedOK: Mandatory, Read only, 32 bit counter.
This contains a count of frames that are successfully transmitted. This counter is incremented when the TransmitStatus is reported as transmitOK. The update occurs in the LayerMgmtTransmitCounters procedure (5.2.4.2).
- (2) Number of singleCollisionFrames: Mandatory, Read only, 32 bit counter.
This contains a count of frames that are involved in a single collision and are subsequently transmitted successfully. This counter is incremented when the result of a transmission is reported as transmitOK and the attempt value is 2. The update occurs in the LayerMgmtTransmitCounters procedure (5.2.4.2).
- (3) Number of multipleCollisionFrames: Mandatory, Read only, 32 bit counter.
This contains a count of frames that are involved in more than one collision and are subsequently transmitted successfully. This counter is incremented when the TransmitStatus is reported as transmitOK and the value of the attempts variable is greater than 2 and less than or equal to attemptLimit. The update occurs in the LayerMgmtTransmitCounters procedure (5.2.4.2).
- (4) Number of collisionFrames: Recommended, Read only, Array [1..attemptLimit - 1] of 32 bit counters.

This array provides a histogram of collision activity. The indices of this array (1 to attemptLimit - 1) denote the number of collisions experienced in transmitting a frame. Each element of this array contains a counter that denotes the number of frames that have experienced a specific number of collisions. When the TransmitStatus is reported as transmitOK and the value of the attempts variable equals n, then collisionFrames[n-1] counter is incremented. The elements of this array are incremented in the LayerMgmtTransmitCounters procedure (5.2.4.2).

- (5) **Number of octetsTransmittedOK:** Recommended, Read only, 32 bit counter.
This contains a count of data and padding octets of frames that are successfully transmitted. This counter is incremented when the TransmitStatus is reported as transmitOK. The update occurs in the LayerMgmtTransmitCounters procedure (5.2.4.2).
- (6) **Number of Frames with deferredTransmissions:** Recommended, Read only, 32 bit counter.
This contains a count of frames whose transmission was delayed on its first attempt because the medium was busy. This counter is incremented when the Boolean variable deferred has been asserted by the TransmitLinkMgmt function (4.2.8). Frames involved in any collisions are not counted. The update occurs in the LayerMgmtTransmitCounters procedure (5.2.4.2).
- (7) **Number of multicastFramesTransmittedOK:** Optional, Read only, 32 bit counter.
This contains a count of frames that are successfully transmitted, as indicated by the status value transmitOK, to a group destination address other than broadcast. The update occurs in the LayerMgmtTransmitCounters procedure (5.2.4.2).
- (8) **Number of broadcastFramesTransmittedOK:** Optional, Read only, 32 bit counter.
This contains a count of the frames that were successfully transmitted as indicated by the TransmitStatus transmitOK, to the broadcast address. Frames transmitted to multicast addresses are not broadcast frames and are excluded. The update occurs in the LayerMgmtTransmitCounters procedure (5.2.4.2).

5.2.2.1.2 MAC Transmit Error Statistics Descriptions. This section defines the MAC sublayer transmission related error statistics.

- (1) **Number of lateCollision:** Recommended Read only, 32 bit counter.
This contains a count of the times that a collision has been detected later than 512 bit times into the transmitted packet. A late collision is counted twice, i.e., both as a collision and as a lateCollision. This counter is incremented when the lateCollisionCount variable is nonzero. The update is incremented in the LayerMgmtTransmitCounters procedure (5.2.4.2).
- (2) **Number of frames aborted due to excessiveCollision:** Recommended, Read only, 32 bit counter.
This contains a count of the frames that due to excessive collisions are not transmitted successfully. This counter is incremented when the value of the attempts variable equals attemptLimit during a transmission. The update occurs in the LayerMgmtTransmitCounters procedure (5.2.4.2).
- (3) **Number of frames lost due to internalMACTransmitError:** Recommended, Read only, 32 bit counter.
This contains a count of frames that would otherwise be transmitted by the station, but could not be sent due to an internal MAC sublayer transmit error. If this counter is incremented, then none of the other counters in this section are incremented. The exact meaning and mechanism for incrementing this counter is implementation-dependent.
- (4) **Number of carrierSenseErrors:** Recommended, Read only, 32 bit counter.
This contains a count of times that the carrierSense variable was not asserted or was deasserted during the transmission of a frame without collision (see 7.2.4.6). This counter is incremented when the carrierSenseFailure flag is true at the end of transmission. The update occurs in the LayerMgmtTransmitCounters procedure (5.2.4.2).
- (5) **Number of frames with excessiveDeferral:** Optional, Read only, 32 bit counter.
This contains a count of frames that were deferred for an excessive period of time. This counter may only be incremented once per LLC transmission. This counter is incremented when the excessDefer flag is set. The update occurs in the LayerMgmtTransmitCounters procedure (5.2.4.2).

5.2.2.1.3 MAC Receive Statistics Descriptions

- (1) **Number of framesReceivedOK:** Mandatory, Read only, 32 bit counter.
This contains a count of frames that are successfully received (receiveOK). This does not include frames received with frame-too-long, FCS, length or alignment errors, or frames lost due to internal MAC sublayer error. This counter is incremented when the ReceiveStatus is reported as receiveOK. The update occurs in the LayerMgmtReceiveCounters procedure (5.2.4.3).
- (2) **Number of octetsReceivedOK:** Recommended, Read only, 32 bit counter.
This contains a count of data and padding octets in frames that are successfully received. This does not include octets in frames received with frame-too-long, FCS, length or alignment errors, or frames lost due to internal MAC sublayer error. This counter is incremented when the result of a

reception is reported as a receiveOK status. The update occurs in the LayerMgmtReceiveCounters procedure (5.2.4.3).

- (3) Number of multicastFramesReceivedOK: Optional, Read only, 32 bit counter. This contains a count of frames that are successfully received and are directed to an active non-broadcast group address. This does not include frames received with frame-too-long, FCS, length or alignment errors, or frames lost due to internal MAC sublayer error. This counter is incremented as indicated by the receiveOK status, and the value in the destinationField. The update occurs in the LayerMgmtReceiveCounters procedure (5.2.4.3).
- (4) Number of broadcastFramesReceivedOK: Optional, Read only, 32 bit counter. This contains a count of frames that are successfully received and are directed to the broadcast group address. This does not include frames received with frame-too-long, FCS, length or alignment errors, or frames lost due to internal MAC sublayer error. This counter is incremented as indicated by the receiveOK status, and the value in the destinationField. The update occurs in the LayerMgmtReceiveCounters procedure (5.2.4.3).

5.2.2.1.4 MAC Receive Error Statistics Descriptions. This section defines the MAC sublayer reception related error statistics. Note that a hierarchical order has been established such that when multiple error statuses can be associated with one frame, only one status is returned to the LLC. This hierarchy in descending order is as follows:

frameTooLong
alignmentError
frameCheckError
lengthError

The following counters are primarily incremented based on the status returned to the LLC, and therefore the hierarchical order of the counters is determined by the order of the status.

- (1) Number of frames received with frameCheckSequenceErrors: Mandatory, Read only, 32 bit counter. This contains a count of frames that are an integral number of octets in length and do not pass the FCS check. This counter is incremented when the ReceiveStatus is reported as frameCheckError. The update occurs in the LayerMgmtReceiveCounters procedure (5.2.4.3).
- (2) Number of frames received with alignmentErrors: Mandatory, Read only, 32 bit counter. This contains a count of frames that are not an integral number of octets in length and do not pass the FCS check. This counter is incremented when the ReceiveStatus is reported as alignmentError. The update occurs in the LayerMgmtReceiveCounters procedure (5.2.4.3).
- (3) Number of frames lost due to internalMACReceiveError: Recommended, Read only, 32 bit counter. This contains a count of frames that would otherwise be received by the station, but could not be accepted due to an internal MAC sublayer receive error. If this counter is incremented, then none of the other counters in this section are incremented. The exact meaning and mechanism for incrementing this counter is implementation-dependent.
- (4) Number of frames received with inRangeLengthErrors: Optional, Read only, 32 bit counter. This contains a count of frames with a length field value between the minimum unpadded LLC data size and the maximum allowed LLC data size, inclusive, that does not match the number of LLC data octets received. The counter also contains frames with a length field value less than the minimum unpadded LLC data size. The update occurs in the LayerMgmtReceiveCounters procedure (5.2.4.3).
- (5) Number of frames received with outOfRangeLengthField: Optional, Read only, 32 bit counter. This contains a count of frames with a length field value greater than the maximum allowed LLC data size. The update occurs in the LayerMgmtReceiveCounters procedure (5.2.4.3).
- (6) Number of frames received with frameTooLongErrors: Optional, Read only, 32 bit counter. This contains a count of frames that are received and exceed the maximum permitted frame size. This counter is incremented when the status of a frame reception is frameTooLong. The update occurs in the LayerMgmtReceiveCounters procedure (5.2.4.3).

5.2.2.2 MAC Actions. This subsection defines the actions offered by the MAC sublayer to the LME client.

These actions enable the LME client to influence the behavior of the MAC sublayer, i.e., to execute "actions" on the MAC sublayer for management purposes. Many of the following actions enable or disable some function; if either the enable or disable action is implemented, the corresponding disable or enable action must also be implemented. If the enable/disable action is supported, then its corresponding read action must also be supported.

In implementing any of the following actions, receptions and transmissions that are in progress are completed before the action takes effect.

The security considerations related to the following actions should be properly addressed by the SMAE. The items in parenthesis in the descriptions are the procedures that are affected by these actions.

5.2.2.2.1 MAC Action Definitions

- (1) **initialiseMAC: Mandatory**
Call the Initialize procedure (4.2.7.5). This action also results in the initialization of the PLS.
- (2) **enablePromiscuousReceive: Recommended**
Cause the LayerMgmtRecognizeAddress function to accept frames regardless of their destination address (LayerMgmtRecognizeAddress function).
Frames without errors received solely because this action is set are counted as frames received correctly; frames received in this mode that do contain errors update the appropriate error counters.
- (3) **disablePromiscuousReceive: Recommended**
Cause the MAC sublayer to return to the normal operation of carrying out address recognition procedures for station, broadcast, and multicast group addresses (LayerMgmtRecognizeAddress function).
- (4) **readPromiscuousStatus: Recommended**
Return true if promiscuous mode enabled, and false otherwise (LayerMgmtRecognizeAddress function).
- (5) **addGroupAddress: Recommended**
Add the supplied multicast group address to the address recognition filter (RecognizeAddress function).
- (6) **deleteGroupAddress: Recommended**
Delete the supplied multicast group address from the address recognition filter (RecognizeAddress function).
- (7) **readMulticastAddressList: Recommended**
Return the current multicast address list.
- (8) **enableMacSublayer: Optional**
Cause the MAC sublayer to enter the normal operational state at idle. The PLS is reset by this operation (see 7.2.2.2.1). This is accomplished by setting receiveEnabled and transmitEnabled to true.
- (9) **disableMacSublayer: Optional**
Cause the MAC sublayer to end all transmit and receive operations, leaving it in a disabled state. This is accomplished by setting receiveEnabled and transmitEnabled to false.
- (10) **readMACEnableStatus: Optional**
Return true if MAC sublayer is enabled, and false if disabled. This is accomplished by checking the values of the receiveEnabled and transmitEnabled variables.
- (11) **enableTransmit: Optional**
Enable MAC sublayer frame transmission (TransmitFrame function). This is accomplished by setting transmitEnabled to true.
- (12) **disableTransmit: Optional**
Inhibit the transmission of further frames by the MAC sublayer (TransmitFrame function). This is accomplished by setting transmitEnabled to false.
- (13) **readTransmitEnableStatus: Optional**
Return true if transmission is enabled and false otherwise. This is accomplished by checking the value of the transmitEnabled variable.
- (14) **enableMulticastReceive: Optional**
Cause the MAC sublayer to return to the normal operation of multicast frame reception.
- (15) **disableMulticastReceive: Optional**
Inhibit the reception of further multicast frames by the MAC sublayer.

- (16) readMulticastReceiveStatus: Optional
Return true if multicast receive is enabled, and false otherwise.
- (17) modifyMACAddress: Optional
Change the MAC station address to the one supplied (RecognizeAddress function). Note that the supplied station address shall not have the group bit set and shall not be the null address.
- (18) readMACAddress: Optional
Read the current MAC station address.
- (19) executeSelftest: Optional
Execute a self test and report the results (success or failure). The mechanism employed to carry out the self test is not defined in this standard.

5.2.3 Physical Layer Management Facilities. This section of the standard defines the Layer Management facilities for the Physical Layer.

5.2.3.1 Physical Statistics. The statistics defined in this section are implemented by means of counters.

In the following definition, the term "Read only" specifies that the object cannot be written by the client of the LME.

Note that the carrierSenseFailed statistic is a statistic relating to the physical layer, but is listed and maintained in the MAC sublayer for ease of implementation.

5.2.3.1.1 Physical Statistics Descriptions

- (1) Number of SQETestErrors: Recommended, Read only, 32⁸ bit counter.
This contains a count of times that the SQE_TEST_ERROR was received. The SQE_TEST_ERROR is set in accordance with the rules for verification of the SQE detection mechanism in the PLS Carrier Sense Function (see 7.2.4.6).

5.2.4 Layer Management Model. The following model provides the descriptions for Layer Management facilities.

5.2.4.1 Common Constants and Types. The following are the common constants and types required for the Layer Management procedures:

const

maxFrameSize = ...; (in octets, implementation-dependent, see 4.4)
 maxDeferTime = ...; (2 × (maxFrameSize × 8), in bits, error timer limit for maxDeferTime)
 maxLarge = 4294967295; (maximum value (2³² - 1) of wraparound 32 bit counter)
 max64 = xxxxxxxx; (maximum value (2⁶⁴ - 1) of wraparound 64 bit counter)
 oneBitTime = 1; (the period it takes to transmit one bit)

type

CounterLarge = 0..maxLarge--See footnote.;

5.2.4.2 Transmit Variables and Procedures. The following items are specific to frame transmission:

var

excessDefer: Boolean; (set in process DeferTest)
 carrierSenseFailure: Boolean; (set in process CarrierSenseTest)
 transmitEnabled: Boolean; (set by MAC action)
 lateCollisionError: Boolean; (set in Section 4 procedure WatchForCollision)
 deferred: Boolean; (set in Section 4 function TransmitLinkMgmt)
 carrierSenseTestDone: Boolean; (set in process CarrierSenseTest)

⁸32 bit counter size specification is not a part of this ISO/IEC standard. Resolution of 32 vs. 64 bit counter size will be addressed during the further work required to develop this section into a specification sufficient for ISO/IEC interoperability requirements.

lateCollisionCount: 0..attemptLimit - 1; (count of late collision that is used in Section 4 TransmitLinkMgmt)

(MAC transmit counters)
framesTransmittedOK: CounterLarge; (mandatory)
singleCollisionFrames: CounterLarge; (mandatory)
multipleCollisionFrames: CounterLarge; (mandatory)
collisionFrames: array [1..attemptLimit - 1] of CounterLarge; (recommended)
octetsTransmittedOK: CounterLarge; (recommended)
deferredTransmissions: CounterLarge; (recommended)
multicastFramesTransmittedOK: CounterLarge; (optional)
broadcastFramesTransmittedOK: CounterLarge; (optional)
(MAC transmit error counters)
lateCollision: CounterLarge; (recommended)
excessiveCollision: CounterLarge; (recommended)
carrierSenseErrors: CounterLarge; (optional)
excessiveDeferral: CounterLarge; (optional)

Procedure LayerMgmtTransmitCounters is invoked from the TransmitLinkMgmt function in 4.2.8 to update the transmit and transmit error counters.

```
procedure LayerMgmtTransmitCounters;  
begin  
  while not carrierSenseTestDone do nothing;  
  if transmitSucceeding then  
    begin  
      IncLargeCounter(framesTransmittedOK);  
      SumLarge(octetsTransmittedOK, dataSize/8); (dataSize (in bits) is defined in 4.2.7.1)  
      if destinationField = ... (check to see if to a multicast destination)  
        then IncLargeCounter(multicastFramesTransmittedOK);  
      if destinationField = ... (check to see if to a broadcast destination)  
        then IncLargeCounter(broadcastFramesTransmittedOK);  
  
      if attempts > 1 then  
        begin (transmission delayed by collision)  
          if attempts = 2 then  
            IncLargeCounter(singleCollisionFrames) (delay by 1 collision)  
          else (attempts > 2, delayed by multiple collisions)  
            IncLargeCounter(multipleCollisionFrames)  
          IncLargeCounter(collisionFrames[attempts - 1]);  
          end; (delay by collision)  
        end; (transmitSucceeding)  
  
      if deferred and (attempts = 1) then  
        IncLargeCounter(deferredTransmissions);  
      if lateCollisionCount > 0 then (test if late collision detected)  
        SumLarge(lateCollision, lateCollisionCount);  
      if attempts = attemptLimit and not transmitSucceeding then  
        IncLargeCounter(excessiveCollision);  
      if carrierSenseFailure then  
        IncLargeCounter(carrierSenseErrors);  
      if excessDefer then  
        IncrementLargeCounter(excessiveDeferral);  
    end; (LayerMgmtTransmitCounters)
```

The DeferTest process sets the excessDefer flag if a transmission attempt has been deferred for a period of time longer than maxDeferTime.

```

process DeferTest;
  var deferBitTimer: 0..maxDeferTime;
begin
  cycle
  begin
    deferCount := 0;
    while frameWaiting and not excessDefer do
      begin
        Wait(oneBitTime); {see 4.3.3}
        if deferBitTimer = maxDeferTime then
          excessDefer := true
        else
          deferBitTimer := deferBitTimer + 1;
        end; {while}
      while transmitting do nothing;
    end; {cycle}
  end; {DeferTest}

```

The CarrierSenseTest process sets the carrierSenseFailure flag if carrier sense disappears while transmitting or if it never appears during an entire transmission.

```

process CarrierSenseTest;
  var
    carrierSeen: Boolean; {Running indicator of whether or not carrierSense has been true at any
                           time during the current transmission}
    collisionSeen: Boolean; {Running indicator of whether or not the collisionDetect asserted any
                             time during the entire transmission}
begin
  cycle {main loop}
  while not transmitting do nothing; {wait for start of transmission}
  carrierSenseFailure := false;
  carrierSeen := false;
  collisionSeen := false;
  carrierSenseTestDone := false;
  while transmitting do
    begin {inner loop}
      if carrierSense then
        carrierSeen := true;
      else
        if carrierSense then {carrierSense disappeared before end of transmission}
          carrierSenseFailure := true;
        if collisionDetect then
          collisionSeen := true;
        end; {inner loop}
      if not carrierSeen then
        carrierSenseFailure := true {carrier sense never appeared}
      else
        if collisionSeen then
          carrierSenseFailure := false;
          carrierSenseTestDone := true;
        end; {main loop}
    end; {CarrierSenseTest}

```

5.2.4.3 Receive Variables and Procedures. The following items are specific to frame reception:

```

var
  receiveEnabled: Boolean; {set by MAC action}

```

(MAC receive counters)
framesReceivedOK: CounterLarge; [mandatory]
octetsReceivedOK: CounterLarge; [recommended]

(MAC receive error counters)
frameCheckSequenceErrors: CounterLarge; [mandatory]
alignmentErrors: CounterLarge; [mandatory]
inRangeLengthErrors: CounterLarge; [optional]
outOfRangeLengthField: CounterLarge; [optional]
frameTooLongErrors: CounterLarge; [optional]

(MAC receive address counters)
multicastFramesReceivedOK: CounterLarge; [optional]
broadcastFramesReceivedOK: CounterLarge; [optional]

Procedure `LayerMgmtReceiveCounters` is called by `ReceiveLinkMgmt` in 4.2.9 and increments the appropriate receive counters.

```
procedure LayerMgmtReceiveCounters (status: ReceiveStatus);
begin
  case status of
    receiveDisabled:
      begin
        nothing;
      end (receiveDisabled)
    receiveOK:
      begin
        IncLargeCounter(framesReceivedOK);
        SumLarge(octetsReceivedOK, dataSize/8); (dataSize (in bits) is defined in 4.2.7.1)
        if destinationField = ... (check to see if to a multicast destination)
          then IncLargeCounter(multicastFramesReceivedOK);
        if destinationField = ... (check to see if to a broadcast destination)
          then IncLargeCounter(broadcastFramesReceivedOK);
        end; (receiveOK)
      frameTooLong:
        begin
          IncLargeCounter(frameTooLongErrors);
        end; (frameTooLong)
      frameCheckError:
        begin
          IncLargeCounter(frameCheckSequenceErrors);
        end; (frameCheckError)
      alignmentError:
        begin
          IncLargeCounter(alignmentErrors);
        end; (alignmentError)
      lengthError:
        begin
          if (length field value is between the minimum unpadding LLCDataSize and maximum allowed
              LLCDataSize inclusive, and does not match the number of LLC data octets received) or
              (length field value is less than the minimum allowed unpadding LLC data size and the number
              of LLC data octets received is greater than the minimum unpadding LLCDataSize) then
            IncLargeCounter(inRangeLengthError);
          end; (lengthError)
        end; (case status)
      if (length field value is greater than the maximum allowed LLCDataSize) then
        IncLargeCounter(outOfRangeLengthField);
      end;
```

```
end; {LayerMgmtReceiveCounters}
```

Function `LayerMgmtRecognizeAddress` checks if reception of certain addressing types has been enabled. Note that in Pascal, assignment to a function causes the function to return immediately.

```
function LayerMgmtRecognizeAddress(address: AddressValue): Boolean;
begin
  if {promiscuous receive enabled} then
    LayerMgmtRecognizeAddress := true;
  if address = ... {MAC station address} then
    LayerMgmtRecognizeAddress := true;
  if address = ... {broadcast address} then
    LayerMgmtRecognizeAddress := true;
  if address = ... {one of the addresses on the multicast list and multicast reception is enabled} then
    LayerMgmtRecognizeAddress := true;
  LayerMgmtRecognizeAddress := false;
end; {LayerMgmtRecognizeAddress}
```

5.2.4.4 Common Procedures. Procedure `LayerMgmtInitialize` initializes all the variables and constants required to implement Layer Management.

```
procedure LayerMgmtInitialize;
begin
  {initialize flags for enabling/disabling transmission and reception}
  receiveEnabled := true;
  transmitEnabled := true;

  {initialize transmit flags for DeferTest and CarrierSenseTest}
  deferred := false;
  lateCollisionError := false;
  excessDefer := false;
  carrierSenseFailure := false;
  carrierSenseTestDone := false;

  {Initialize all MAC sublayer management counters to zero}

end; {LayerMgmtInitialize}
```

Procedure `IncLargeCounter` increments a 32 bit wraparound counter.

```
procedure IncLargeCounter (var counter: CounterLarge);
begin
  {increment the 32 bit counter}
end; {IncLargeCounter}
```

Procedure `SumLarge` adds a value to a 32 bit wraparound counter.

```
procedure SumLarge (
  var counter: CounterLarge;
  var offset: Integer);
begin
  {add offset to the 32 bit counter}
end; {SumLarge}
```

6. PLS Service Specifications

6.1 Scope and Field of Application. This section specifies the services provided by the Physical Signaling (PLS) sublayer to the MAC sublayer for the CSMA/CD section of the Local Area Network Standard, Fig 6-1. The services are described in an abstract way and do not imply any particular implementation.

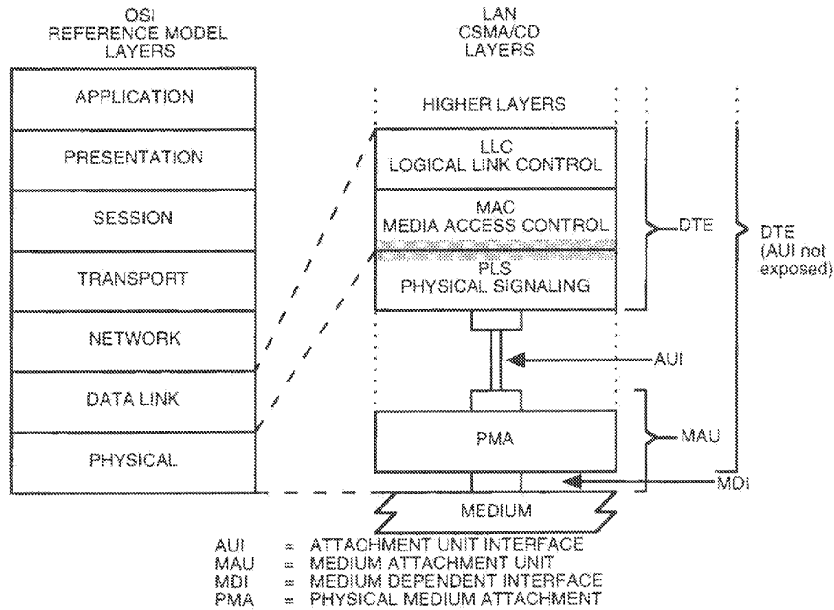

Fig 6-1
Service Specification Relationship to the IEEE 802.3 CSMA/CD LAN Model

6.2 Overview of the Service

6.2.1 General Description of Services Provided by the Layer. The services provided by the PLS sublayer allow the local MAC sublayer entity to exchange data bits (PLS data_units) with peer MAC sublayer entities.

6.2.2 Model Used for the Service Specification. The model used in this service specification is identical to that used in 1.2.2.1.

6.2.3 Overview of Interactions. The primitives associated with the MAC sublayer to PLS sublayer interface fall into two basic categories:

- (1) Service primitives that support MAC peer-to-peer interactions
- (2) Service primitives that have local significance and support sublayer-to-sublayer interactions

The following primitives are grouped into these two categories:

- (1) Peer-to-Peer
 - PLS_DATA.request
 - PLS_DATA.indication

- (2) Sublayer-to-Sublayer
 PLS_CARRIER.indication
 PLS_SIGNAL.indication

The PLS_DATA primitives support the transfer of data from a single MAC sublayer entity to all other peer MAC sublayer entities contained within the same local area network defined by the broadcast medium.

NOTE: This also means that all bits transferred from a given MAC sublayer entity will in turn be received by the entity itself.

The PLS_CARRIER and the PLS_SIGNAL primitives provide information needed by the local MAC sublayer entity to perform the media access functions.

6.2.4 Basic Services and Options. All of the service primitives described in this section are considered mandatory.

6.3 Detailed Service Specification

6.3.1 Peer-to-Peer Service Primitives

6.3.1.1 PLS_DATA.request

6.3.1.1.1 Function. This primitive defines the transfer of data from the MAC sublayer to the local PLS entity.

6.3.1.1.2 Semantics of the Service Primitive. The primitive shall provide the following parameters:

PLS_DATA.request (OUTPUT_UNIT)

The OUTPUT_UNIT parameter can take on one of three values: ONE, ZERO, or DATA_COMPLETE and represent a single data bit. The DATA_COMPLETE value signifies that the Media Access Control sublayer has no more data to output.

6.3.1.1.3 When Generated. This primitive is generated by the MAC sublayer to request the transmission of a single data bit on the physical medium or to stop transmission.

6.3.1.1.4 Effect of Receipt. The receipt of this primitive will cause the PLS entity to encode and transmit either a single data bit or to cease transmission.

6.3.1.2 PLS_DATA.indicate

6.3.1.2.1 Function. This primitive defines the transfer of data from the PLS sublayer to the MAC sublayer.

6.3.1.2.2 Semantics of the Service Primitive. The semantics of the primitive are as follows:

PLS_DATA.indicate (INPUT_UNIT)

The INPUT_UNIT parameter can take one of two values each representing a single bit: ONE or ZERO.

6.3.1.2.3 When Generated. The PLS_DATA.indicate is generated to all MAC sublayer entities in the network after a PLS_DATA.request is issued.

NOTE: An indicate is also presented to the MAC entity that issued the request.

6.3.1.2.4 Effect of Receipt. The effect of receipt of this primitive by the MAC sublayer is unspecified.

6.3.2 Sublayer-to-Sublayer Service Primitives

6.3.2.1 PLS_CARRIER.indicate

6.3.2.1.1 Function. This primitive transfers the status of the activity on the physical medium from the PLS sublayer to the MAC sublayer.

6.3.2.1.2 Semantics of the Service Primitive. The semantics of the primitive are as follows:

PLS_CARRIER.indicate (CARRIER_STATUS)

The CARRIER_STATUS parameter can take one of two values: CARRIER_ON or CARRIER_OFF. The CARRIER_ON value indicates that the DTE Physical Layer had received an *input* message or a *signal_quality_error* message from the MAU. The CARRIER_OFF value indicates that the DTE Physical Layer had received an *input_idle* message and is not receiving an SQE *signal_quality_error* message from the MAU.

6.3.2.1.3 When Generated. The PLS_CARRIER.indicate service primitive is generated whenever CARRIER_STATUS makes a transition from CARRIER_ON to CARRIER_OFF or vice versa.

6.3.2.1.4 Effect of Receipt. The effect of receipt of this primitive by the MAC sublayer is unspecified.

6.3.2.2 PLS_SIGNAL.indicate

6.3.2.2.1 Function. This primitive transfers the status of the Physical Layer signal quality from the PLS sublayer to the MAC sublayer.

6.3.2.2.2 Semantics of the Service Primitive. The semantics of the service primitive are as follows:

PLS_SIGNAL.indicate (SIGNAL_STATUS)

The SIGNAL_STATUS parameter can take one of two values: SIGNAL_ERROR or NO_SIGNAL_ERROR. The SIGNAL_ERROR value indicates to the MAC sublayer that the PLS has received a *signal_quality_error* message from the MAU. The NO_SIGNAL_ERROR value indicates that the PLS has ceased to receive *signal_quality_error* messages from the MAU.

6.3.2.2.3 When Generated. The PLS_SIGNAL.indicate service primitive is generated whenever SIGNAL_STATUS makes a transition from SIGNAL_ERROR to NO_SIGNAL_ERROR or vice versa.

6.3.2.2.4 Effect of Receipt. The effect of receipt of this primitive by the MAC sublayer is unspecified.

7. Physical Signaling (PLS) and Attachment Unit Interface (AUI) Specifications

7.1 Scope. This section defines the logical, electrical, and mechanical characteristics for the PLS and AUI between Data Terminal Equipment and Medium Attachment Units used in CSMA/CD local area networks. The relationship of this specification to the entire ISO [IEEE] Local Area Network standards is shown in Fig 7-1. The purpose of this interface is to provide an interconnection that is simple and inexpensive and that permits the development of simple and inexpensive MAUs.

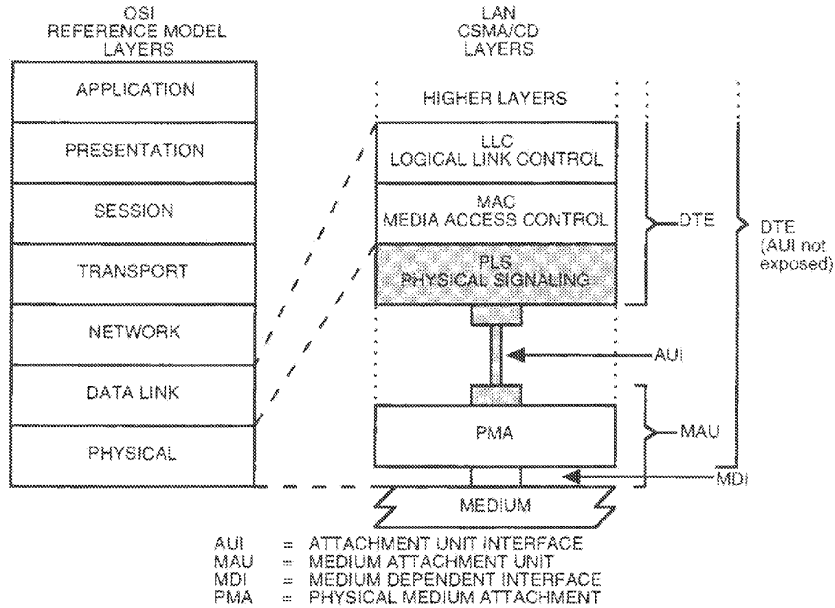

Fig 7-1
Physical Layer Partitioning, Relationship to the ISO Open Systems Interconnection (OSI) Reference Model

This interface has the following characteristics:

- (1) Capable of supporting one or more of the specified data rates
- (2) Capable of driving up to 50 m (164 ft) of cable
- (3) Permits the DTE to test the AUI, AUI cable, MAU, and the medium itself
- (4) Supports MAUs for baseband coax, broadband coax, and baseband fiber

7.1.1 Definitions

Attachment Unit Interface (AU Interface) (AUI). In a local area network, the interface between the medium attachment unit and the data terminal equipment within a data station.

NOTE: The AUI carries encoded control and data signals between the DTE's PLS sublayer and the MAU's PMA sublayer and provides for duplex data transmission.

BR. The rate of data throughput (bit rate) on the medium in bits per second.

bit time. The duration of one bit symbol (1/BR).

circuit. The physical medium on which signals are carried across the AUI. The data and control circuits consist of an A circuit and a B circuit forming a balanced transmission system so that the signal carried on the B circuit is the inverse of the signal carried on the A circuit.

Clocked Data One (CD1). A Manchester encoded data "1." A CD1 is encoded as a LO for the first half of the bit-cell and a HI for the second half of the bit-cell.

Clocked Data Zero (CD0). A Manchester encoded data "0." A CD0 is encoded as a HI for the first half of the bit-cell and a LO for the second half of the bit-cell.

Control Signal One (CS1). An encoded control signal used on the Control In and Control Out circuits. A CS1 is encoded as a signal at half the bit rate (BR/2).

Control Signal Zero (CS0). An encoded control signal used on the Control In and Control Out circuits. A CS0 is encoded as a signal at the bit rate (BR).

idle (IDL). A signal condition where no transition occurs on the transmission line is used to define the end of a frame and ceases to exist after the next LO to HI transition on the AUI circuits. An IDL always begins with a HI signal level. A driver is required to send the IDL signal for at least 2 bit times and a receiver is required to detect IDL within 1.6 bit times. See 7.3 for additional details.

7.1.2 Summary of Major Concepts

- (1) Each direction of data transfer is serviced with two (making a total of four) balanced circuits: "Data" and "Control."
- (2) The Data and Control circuits are independently self-clocked, thereby, eliminating the need for separate timing circuits. This is accomplished with encoding of all signals. The Control circuit signaling rate is nominally (but not of necessity exactly) equal to the Data circuit signaling rate.
- (3) The Data circuits are used only for data transfer. No control signals associated with the interface are passed on these circuits. Likewise, the Control circuits are used only for control message transfer. No data signals associated with the interface are passed on these circuits.

7.1.3 Application. This standard applies to the interface used to interconnect Data Terminal Equipment (DTE) to a MAU that is not integrated as a physical part of the DTE. This interface is used to

- (1) Provide the DTE with media independence for baseband coax, broadband coax, and baseband fiber media so that identical PLS, MAC and LLC may be used with any of these media.
- (2) Provide for the separation by cable of up to 50 m (164 ft) the DTE and the MAU.

7.1.4 Modes of Operation. The AUI can operate in two different modes. All interfaces shall support the normal mode. The monitor mode is optional.

When the interface is being operated in the *normal* mode, the AUI is logically connected to the MDI. The DTE is required to follow the media access algorithms, which provide a single access procedure compatible with all local area network media, to send data over the AUI. The MAU always sends back to the DTE whatever data the MAU receives on the MDI.

When the interface is in the optional *monitor* mode, the MAU's transmitter is logically isolated from the medium. The MAU, in this mode, functions as an observer on the medium. Both the input function and the signal quality error function are operational (see the MAU state diagrams for specific details).

7.1.5 Allocation of Function. The allocation of functions in the AUI is such that the majority of the functionality required by the interface can be provided by the DTE, leaving the MAU as simple as possible. This division of functions is based upon the recognition of the fact that since, in many cases, the MAU may be located in an inaccessible location adjacent to the physical medium, service of the MAU may often be difficult and expensive.

7.2 Functional Specification. The AUI is designed to make the differences among the various media as transparent as possible to the DTE. The selection of logical control signals and the functional procedures

are all designed to this end. Figure 7-2 is a reference model, a generalized MAU as seen by the DTE through the AUI.

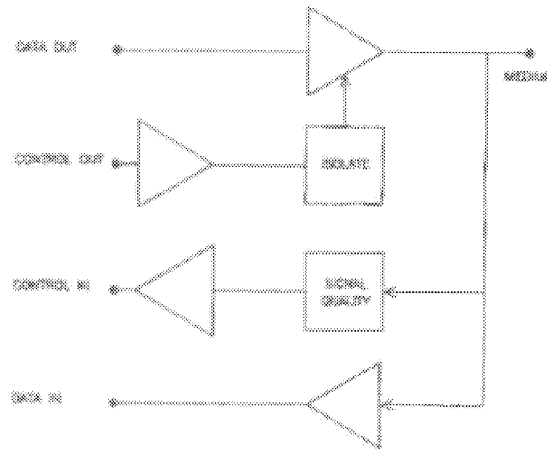

NOTE: The AUI (comprised of DO, DI, CO, CI circuits) is not exposed when the MAU is, optionally, part of the DTE.

Fig 7-2
Generalized MAU Model

Many of the terms used in this section are specific to the interface between this sublayer and the MAC sublayer. These terms are defined in the Service Specification for the PLS sublayer.

7.2.1 PLS-PMA (DTE-MAU) Interface Protocol. The DTE and MAU communicate by means of a simple protocol across the AUI.

7.2.1.1 PLS to PMA Messages. The following messages can be sent by PLS sublayer entities in the DTE to PMA sublayer entities in the MAU:

Message	Meaning
<i>output</i>	Output information
<i>output_idle</i>	No data to be output
<i>normal</i>	Cease to isolate the MAU
(Optional)	
<i>isolate</i>	Isolate MAU
<i>mau_request</i>	Request that the MAU be made available

7.2.1.1.1 *output* Message. The PLS sublayer sends an output message to the PMA sublayer when the PLS sublayer receives an OUTPUT_UNIT from the MAC sublayer.

The physical realization of the *output* message is a CD0 or a CD1 sent by the DTE to the MAU on the Data Out circuit. The DTE sends a CD0 if the OUTPUT_UNIT is a ZERO or a CD1 if the OUTPUT_UNIT is a ONE. This message is time coded—that is, once this message has been sent, the function is not completed over the AUI until one bit time later. The *output* message cannot be sent again until the bit cell being sent as a result of sending the previous *output* message is complete.

7.2.1.1.2 *output_idle* Message. The PLS sublayer sends an *output_idle* message to the PMA sublayer at all times when the MAC sublayer is not in the process of transferring output data across the MAC to PLS interface. The *output_idle* message is no longer sent (and the first OUTPUT_UNIT is sent using the *output* message) as soon after the arrival of the first OUTPUT_UNIT as the MAU can be made available for data output. The *output_idle* message is again sent to the MAU when the DATA_COMPLETE is received from the MAC sublayer. The detailed usage of the *output_idle* message is shown in Fig 7-5.

The physical realization of the *output_idle* message is IDL sent by the DTE to the MAU on the Data Out circuit.

7.2.1.1.3 *normal* Message. The PLS sublayer sends a *normal* message to the PMA sublayer after it receives the PLS *start* message from the PLS Reset and Identify Function. The *normal* message is also sent after receipt of RESET_MONITOR_MODE from the management entity. The *normal* message is sent continuously by the PLS sublayer to the MAU, unless the PLS Output Function requires that the *mau_request* message be sent to permit data output. If *mau_request* is sent during data output, the sending of *normal* will be resumed when the PLS Output Function returns to the IDLE state. The *normal* signal is reset by the SET_MONITOR_MODE (this reset function is described more fully by Fig 7-4).

7.2.1.1.4 *isolate* Message (Optional). The PLS sublayer sends an *isolate* message to the PMA (in the MAU) whenever the PLS sublayer receives SET_MONITOR_MODE from the management entity. In response to the *isolate* message, the MAU causes the means employed to impress data on the physical medium to be positively prevented from affecting the medium. Since signaling and isolation techniques differ from medium to medium, the manner in which this positive isolation of the transmitting means is accomplished is specified in the appropriate MAU section. However, the intent of this positive isolation of the transmitter is to ensure that the MAU will not interfere with the physical medium in such a way as to affect transmissions of other stations even in the event that the means normally employed to prevent the transmitter from affecting the medium have failed to do so. The specification of positive isolation is not to be construed to preclude use of either active or passive devices to accomplish this function.

The physical realization of the *isolate* message is a CSU signal sent by the DTE to the MAU over the Control Out circuit.

7.2.1.1.5 *mau_request* Message (Optional). The PLS sublayer sends the *mau_request* message to the PMA sublayer if the PMA sublayer is sending the *mau_not_available* message and the MAC sublayer has sent the first OUTPUT_UNIT of a new transmission. The PLS sublayer continues to send the *mau_request* message to the MAU until the MAC sublayer sends the DATA_COMPLETE request to the PLS sublayer across the MAC to PLS interface. See Figs 7-3, 7-5, and 7-9 for details.

In addition, the *mau_request* message is used by the Reset and Identify Function in the IDENTIFY 2 state to determine whether the MAU has the Isolate Function.

The physical realization of *mau_request* is a CSI sent by the DTE to the MAU on the Control Out circuit.

The physical realization of the *normal* message is the IDL signal sent by the DTE to the MAU on the Control Out circuit. In the absence of the CO circuit, MAUs implementing the Isolate Function shall act as if the *normal* message is present. The CO circuit components may be absent from the DTE, AUI, or MAU.

7.2.1.2 PMA to PLS Interface. The following messages can be sent by the Physical Medium Attachment sublayer entities in the MAU to the PLS sublayer entities in the DTE:

Message	Meaning
<i>input</i>	Input information
<i>input_idle</i>	No input information
<i>signal_quality_error</i>	Error detected by MAU
<i>mau_available</i>	MAU is available for output
(Optional)	
<i>mau_not_available</i>	MAU is not available for output

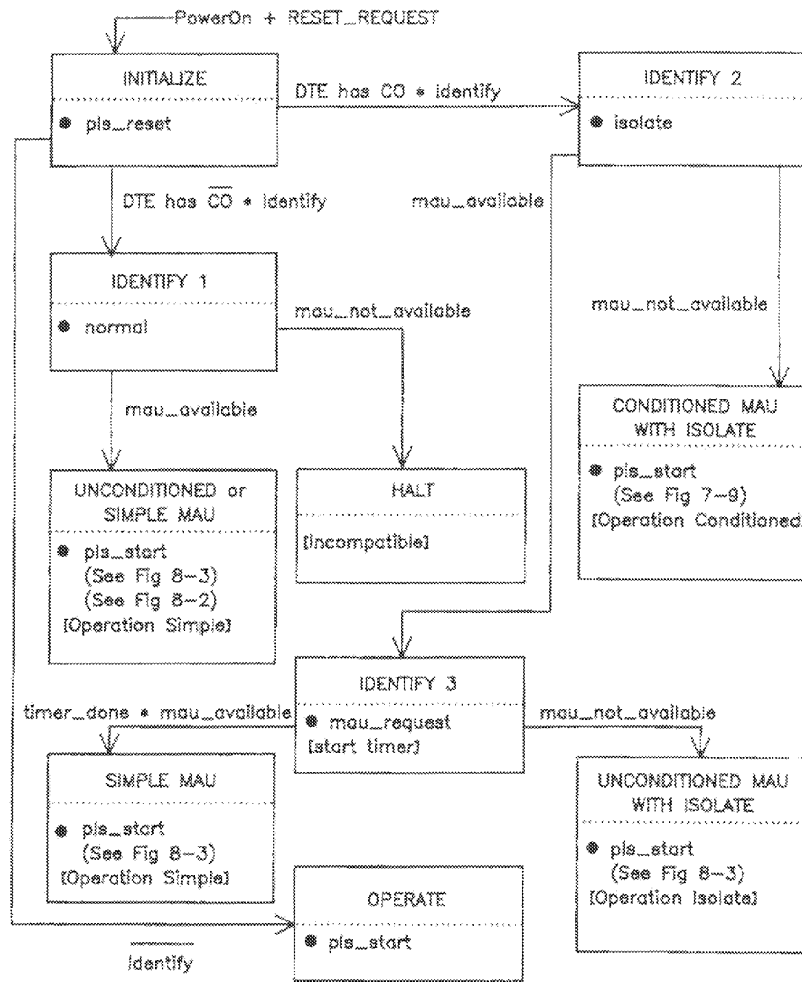

- NOTES: (1) All states may be omitted except INITIALIZE and OPERATE
 (2) "Identify" means DTE can recognize uniquely all CI messages and the entire function has been implemented
 (3) "Identify" with bar means DTE fails to recognize *mau_not_available* or has a partial implementation of the function

Fig 7-3
PLS Reset and Identify Function

7.2.1.2.1 input Message. The PMA sublayer sends an *input* message to the PLS sublayer when the MAU has received a bit from the medium and is prepared to transfer this bit to the DTE. The actual mapping of the signals on the medium to the type of *input* message to be sent to the DTE is contained in the specifications for each specific MAU type. In general, when the *signal_quality_error* message is being sent by the MAU, the symmetry specifications for circuit DI are not guaranteed to be met.

The physical realization of the *input* message consists of CD0 or CD1 waveforms. If the *signal_quality_error* message is being sent from the MAU, the input waveform is unpredictable.

NOTE: This signal is not necessarily retimed by the MAU. Consult the appropriate MAU specification for timing and jitter.

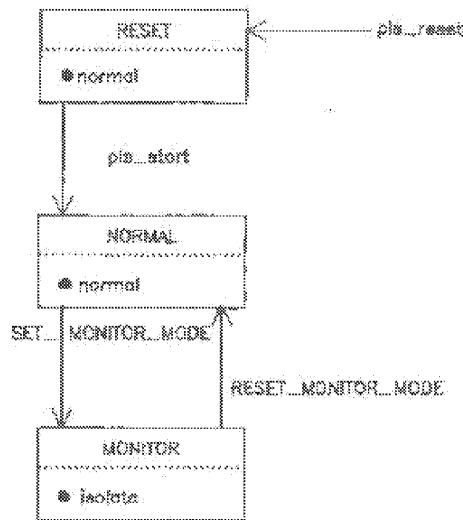

NOTE: Monitor State is optional.

Fig 7-4
PLS Mode Function

7.2.1.2.2 *input_idle* Message. The PMA sublayer sends an *input_idle* message to the PLS sublayer when the MAU does not have data to send to the DTE.

The physical realization of the *input_idle* message is an IDL sent by the MAU to the DTE on the Data In circuit.

7.2.1.2.3 *signal_quality_error* Message. The PMA sublayer sends a *signal_quality_error* message to the PLS sublayer in response to any of three possible conditions. These conditions are improper signals on the medium, collision on the medium, and reception of the *output_idle* message. They are described in the following numbered paragraphs. The physical realization of the *signal_quality_error* message is a CS0 sent by the MAU to the DTE on the Control In circuit.

NOTE: The MAU is required to insert the *signal_quality_error* message at the appropriate times whenever the MAU is powered, and not just when the DTE is requesting data output. See Figs 7-9, 8-2, and 5-3 for details.

- (1) **Improper Signals on the Medium.** The MAU may send the *signal_quality_error* message at any time due to improper signals on the medium. The exact nature of these improper signals are medium-dependent. Typically, this condition might be caused by a malfunctioning MAU (for example, repeater or head-end) connected to the medium or by a break or short in the medium. See the appropriate MAU specification for specific conditions that may cause improper signals on a given medium.
- (2) **Collision.** Collision occurs when more than one MAU is transmitting on the medium. The local MAU shall send the *signal_quality_error* message in every instance when it is possible for it to ascertain that more than one MAU is transmitting on the medium. The MAU shall make the best determination possible. The MAU shall not send the *signal_quality_error* message when it is unable to determine conclusively that more than one MAU is transmitting.
- (3) ***signal_quality_error* Message Test.** The MAU sends the *signal_quality_error* message at the completion of the Output Function. See Fig 7-9 and Section 6 for a more complete description of this test.

7.2.1.2.4 *mau_available* Message. The PMA sublayer sends the *mau_available* message to the PLS sublayer when the MAU is available for output. The *mau_available* message is always sent by a MAU that is always prepared to output data except when it is required to signal the *signal_quality_error*

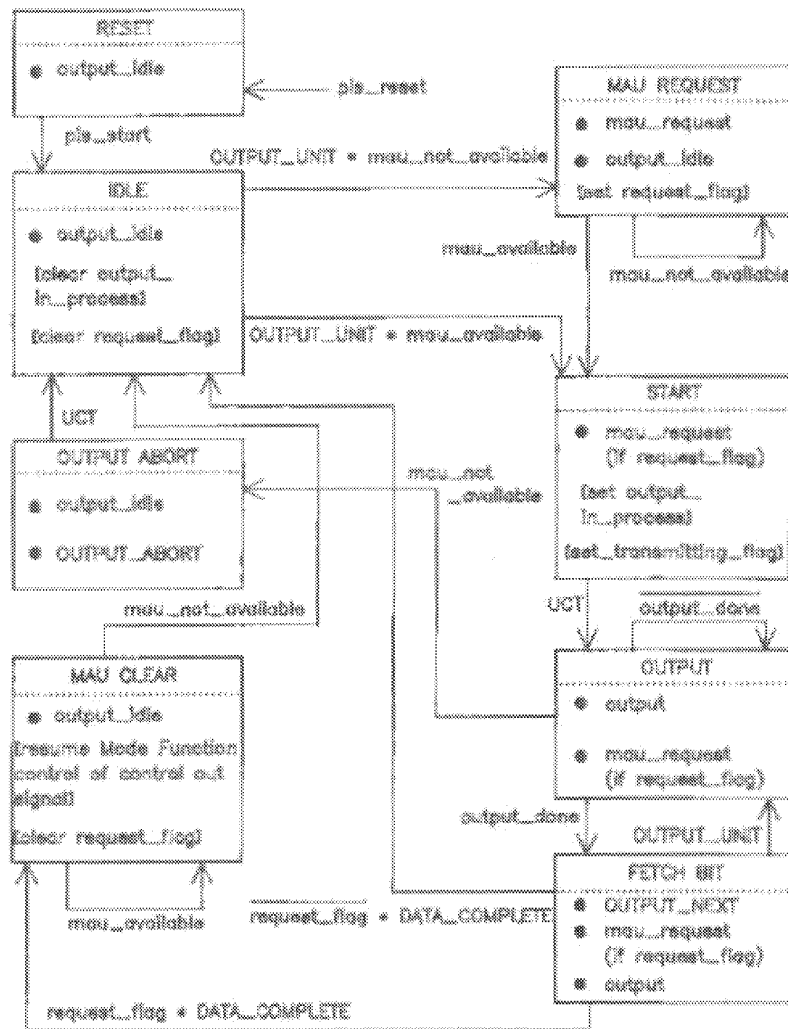

NOTE: UCT = unconditional transition

Fig 7-5
PLS Output Function

message. Such a MAU does not require *mau_request* to prepare itself for data output. See Figs 7-3, 7-5, and 7-9 for details.

The physical realization of the *mau_available* message is an IDL sent by the MAU to the DTE on the Control In circuit.

7.2.1.2.5 *mau_not_available* Message (OPTIONAL). The PMA sublayer sends a *mau_not_available* message to the PLS sublayer when the MAU is not available for output. Figure 7-5 shows the relationship of *mau_not_available* to the Output Function.

The *mau_not_available* message is also used by a MAU that contains the Isolate Function and does not need to be conditioned for output to signal the presence of the Isolate Function during the PLS Reset Function (see Fig 7-3 and 8-3).

The physical realization of the *mau_not_available* message is a CSI sent by the MAU to the DTE on the Control In circuit.

7.2.2 PLS Interface to MAC and Management Entities. The PLS sublayer interfaces described here are for reference only. This section specifies the services sent between the MAC sublayer and the PLS sublayer.

7.2.2.1 PLS-MAC Interface. The following messages can be sent between PLS sublayer entities and MAC sublayer entities:

Message	Meaning
OUTPUT_UNIT	Data sent to the MAU
OUTPUT_STATUS	Response to OUTPUT_UNIT
INPUT_UNIT	Data received from the MAU
CARRIER_STATUS	Indication of input activity
SIGNAL_STATUS	Indication of error/no error condition

7.2.2.1.1 OUTPUT_UNIT. The MAC sublayer sends the PLS sublayer an OUTPUT_UNIT every time the MAC sublayer has a bit to send. Once the MAC sublayer has sent an OUTPUT_UNIT to the PLS sublayer, it may not send another OUTPUT_UNIT until it has received an OUTPUT_STATUS message from the PLS sublayer. The OUTPUT_UNIT is a ONE if the MAC sublayer wants the PLS sublayer to send a CD1 to the PMA sublayer, a ZERO if a CD0 is desired, or a DATA_COMPLETE if an IDL is desired.

7.2.2.1.2 OUTPUT_STATUS. The PLS sublayer sends the MAC sublayer OUTPUT_STATUS in response to every OUTPUT_UNIT received by the PLS sublayer. OUTPUT_STATUS sent is an OUTPUT_NEXT if the PLS sublayer is ready to accept the next OUTPUT_UNIT from the MAC sublayer, or an OUTPUT_ABORT if the PLS sublayer was not able to process the previous OUTPUT_UNIT. (The purpose of OUTPUT_STATUS is to synchronize the MAC sublayer data output with the data rate of the physical medium.)

7.2.2.1.3 INPUT_UNIT. The PLS Sublayer sends the MAC sublayer an INPUT_UNIT every time the PLS receives an *input* message from the PMA sublayer. The INPUT_UNIT is a ONE if the PLS sublayer receives a CD1 from the PMA sublayer, a ZERO if the PLS sublayer receives a CD0 from the PMA sublayer.

7.2.2.1.4 CARRIER_STATUS. The PLS sublayer sends the MAC sublayer CARRIER_STATUS whenever the PLS sublayer detects a change in carrier status. The PLS sublayer sends CARRIER_ON when it receives an *input* or *signal_quality_error* message from the PMA and the previous CARRIER_STATUS that the PLS sublayer sent to the MAC sublayer was CARRIER_OFF. The PLS sublayer sends CARRIER_OFF when it receives an *input_idle* from the PMA sublayer, no *signal_quality_error* (either *mau_available* or *mau_not_available*) message and the previous CARRIER_STATUS that the PLS sublayer sent to the MAC sublayer was CARRIER_ON.

7.2.2.1.5 SIGNAL_STATUS. The PLS sublayer sends the MAC sublayer SIGNAL_STATUS whenever the PLS sublayer detects a change in the signal quality (as reported by the PMA). The PLS sublayer sends SIGNAL_ERROR when it receives a *signal_quality_error* message from the PMA sublayer and the previous SIGNAL_STATUS the PLS sublayer sent was NO_SIGNAL_ERROR. The PLS sublayer sends NO_SIGNAL_ERROR when it receives no *signal_quality_error* (either *mau_available* or *mau_not_available*) message from the PMA sublayer and the previous CARRIER_STATUS that the PLS sent to the MAC sublayer was SIGNAL_ERROR.

7.2.2.2 PLS-Management Entity Interface. The following messages may be sent between the PLS sublayer entities and intralayer or higher layer management entities:

Message	Meaning
RESET_REQUEST	Reset PLS to initial "Power On" state
RESET_RESPONSE	Provides operational information
MODE_CONTROL	Control operation
SQE_TEST	Signal Quality Error test results

7.2.2.2.1 RESET_REQUEST. The management entity sends the PLS sublayer RESET_REQUEST when the PLS sublayer needs to be reset to a known state. Upon receipt of RESET_REQUEST, the PLS sublayer resets all internal logic and restarts all functions. See Fig 7-3 for details.

7.2.2.2.2 RESET_RESPONSE. The PLS sublayer sends the management entity RESET_RESPONSE upon completion of the Reset and Identify Function (see Fig 7-3 and 7.2.4.1) whether invoked due to power on or due to a RESET_REQUEST. Which RESET_RESPONSE was sent is determined by the Reset and Identify Function. A RESET_RESPONSE of OPERATION SIMPLE, OPERATION ISOLATE, or OPERATION CONDITIONED is sent if the MAU is compatible with the DTE and the MAU is simple (no isolate) or if the DTE does not support Isolate even if Isolate is supported by the MAU, supports Isolate but does not require conditioning, or supports Isolate and does require conditioning to output. A RESET_RESPONSE of INCOMPATIBLE is sent if the MAU is not compatible with the DTE (that is, the MAU requires conditioning but the DTE does not support conditioning).

7.2.2.2.3 MODE_CONTROL. The management entity sends MODE_CONTROL to the PLS sublayer to control PLS functions. MODE_CONTROL capabilities are as follows:

Message	Meaning
ACTIVATE PHYSICAL	Supply power on circuit VP
DEACTIVATE PHYSICAL	Remove power from circuit VP
SET_MONITOR_MODE	Send Isolate to MAU
RESET_MONITOR_MODE	Send Normal to MAU

7.2.2.2.4 SQE_TEST. The PLS sublayer sends SQE_TEST to the management entity at the conclusion of each *signal_quality_error* test (see Output Function, 7.2.4.3). The PLS sublayer sends SQE_TEST_ERROR if the *signal_quality_error* test fails or SQE_TEST_OK if the *signal_quality_error* test passes.

7.2.3 Frame Structure. Frames transmitted on the AUI shall have the following structure:

<silence><preamble><sfd><data><etd><silence>

The frame elements shall have the following characteristics:

Element	Characteristics
<silence>	= no transitions
<preamble>	= alternating (CD1) and (CD0) 56 bit times (ending in CD0)
<sfd>	= (CD1)(CD0)(CD1)(CD0)(CD1)(CD0)(CD1)(CD1)
<data>	= 8 × N
<etd>	= IDL

7.2.3.1 Silence. The <silence> delimiter provides an observation window for an unspecified period of time during which no transitions occur on the AUI. The minimum length of this period is specified by the access procedure.

7.2.3.2 Preamble. The <preamble> delimiter begins a frame transmission and provides a signal for receiver synchronization. The signal shall be an alternating pattern of (CD1) and (CD0). This pattern shall be transmitted on the Data Out circuit by the DTE to the MAU for a minimum of 56 bit times at the beginning of each frame. The last bit of the preamble (that is, the final bit of preamble before the start of frame delimiter) shall be a CD0.

The DTE is required to supply at least 56 bits of preamble in order to satisfy system requirements. System components consume preamble bits in order to perform their functions. The number of preamble bits sourced ensures an adequate number of bits are provided to each system component to correctly implement its function.

7.2.3.3 Start of Frame Delimiter (SFD). The <sfd> indicates the start of a frame, and follows the preamble. The <sfd> element of a frame shall be

(CD1)(CD0)(CD1)(CD0)(CD1)(CD0)(CD1)(CD1)

7.2.3.4 Data. The <data> in a transmission shall be in multiples of eight (8) encoded data bits (CD0s and CD1s).

7.2.3.5 End of Transmission Delimiter. The <etd> delimiter indicates the end of a transmission and serves to turn off the transmitter. The signal shall be an IDL.

7.2.4 PLS Functions. The PLS sublayer functions consist of a Reset and Identify Function and five simultaneous and asynchronous functions. These functions are Output, Input, Mode, Error Sense, and Carrier Sense. All of the five functions are started immediately following the completion of the Reset and Identify Function. These functions are depicted in the state diagrams shown in Figs 7-3 through 7-8, using notation described in 1.2.1.

7.2.4.1 Reset and Identify Function. The Reset and Identify Function is executed any time either of two conditions occur. These two conditions are "power on" and the receipt of RESET_REQUEST from the management entity. The Reset and Identify Function initializes all PLS functions, and (optionally) determines the capability of the MAU attached to the AUI. Figure 7-3 is the state diagram of the Reset and Identify Function. The Identify portion of the function is optional.

7.2.4.2 Mode Function. The MAU functions in two modes: normal and monitor. The monitor mode is optional. The state diagram of Fig 7-4 depicts the operation of the Mode Function. When the MAU is operating in the normal mode, it functions as a direct connection between the DTE and the medium. Data sent from the DTE are impressed onto the medium by the MAU and all data appearing on the medium are sent to the DTE by the MAU. When the MAU is operating in the monitor mode, data appearing on the medium is sent to the DTE by the MAU as during the normal mode. *signal_quality_error* is also asserted on the AUI as during operation in the normal mode. However, in the monitor mode, the means employed to impress data on the physical medium is positively prevented from affecting the medium. Since signaling and isolation techniques differ from medium to medium, the manner in which this positive isolation of the transmitting means is accomplished is specified in the appropriate MAU document. However, the intent of this positive isolation of the transmitter is to ensure that the MAU will not interfere with the physical medium in such a way as to affect transmission of other stations even in the event of failure of the normal transmitter disabling control paths within the transmitting mechanism of the MAU.

The monitor mode is intended to permit a network station to determine if it is the source of interference observed on the medium.

NOTE: The monitor mode is intended to be used only by Network Management for fault isolation and network operation verification. It is intended that the *isolate* message provide direct control over the mode function so that these tasks can be performed. IMPROPER USE OF THE ISOLATE FUNCTION CAN CAUSE ERRONEOUS FRAMES. Section 5, Layer Management, provides details on the proper use of this function.

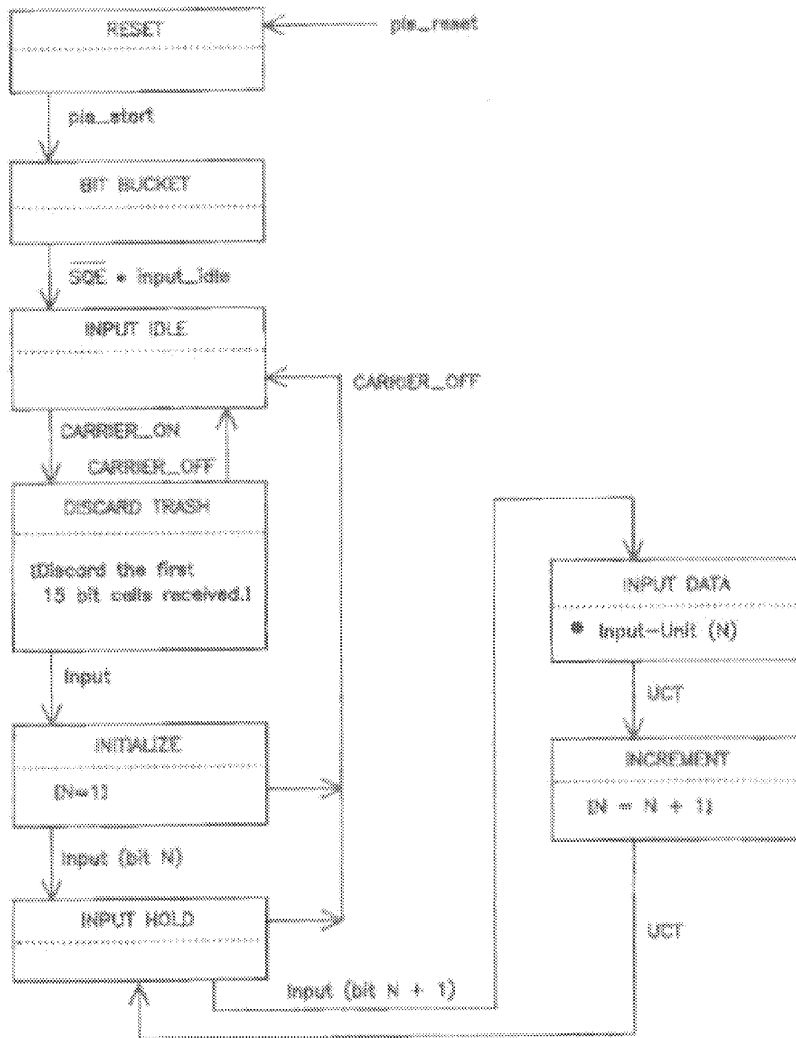

NOTE: UCT= unconditional transition

Fig 7-6
PLS Input Function

7.2.4.3 Output Function. The PLS sublayer Output Function transparently performs the tasks of conditioning the MAU for output and data transfer from the MAC sublayer to the MAU. The state diagram of Fig 7-5 depicts the Output Function operation.

At the conclusion of the Output Function, if a collision has not occurred, a test is performed to verify operation of the signal quality detection mechanism in the MAU and to verify the ability of the AUI to pass the *signal_quality_error* message to the PLS sublayer. The operation of this test in the DTE is shown in Fig 7-8.

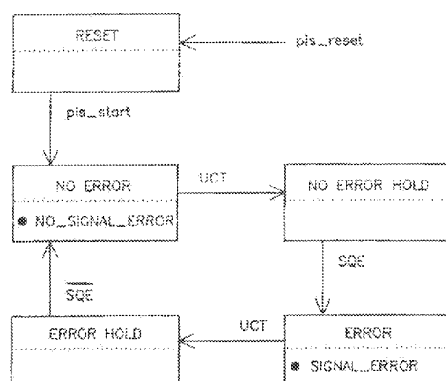

NOTE: UCT = unconditional transition

Fig 7-7
PLS Error Sense Function

7.2.4.4 Input Function. The PLS sublayer Input Function transparently performs the task of data transfer from the MAU to the MAC sublayer. The state diagram of Fig 7-6 depicts the Input Function operation.

7.2.4.5 Error Sense Function. The PLS sublayer Error Sense Function performs the task of sending SIGNAL_STATUS to the MAC sublayer whenever there is a change in the signal quality information received from the MAU. The state diagram of Fig 7-7 depicts the Error Sense Function operation.

7.2.4.6 Carrier Sense Function. The PLS sublayer Carrier Sense Function performs the task of sending CARRIER_STATUS to the MAC sublayer every time there is a change in CARRIER_STATUS. The state diagram of Fig 7-8 depicts the Carrier Sense Function operation.

Verification of the *signal_quality_error* detection mechanism occurs in the following manner (in the absence of a fault on the medium).

- (1) At the conclusion of the output function, the DTE opens a time window during which it expects to see the *signal_quality_error* signal asserted on the Control In circuit. The time window begins when CARRIER_STATUS becomes CARRIER_OFF. If execution of the Output Function does not cause CARRIER_ON to occur, no SQE test occurs in the DTE. The duration of the window shall be at least 4.0 μ s but no more than 8.0 μ s. During the time window (depicted as carrier_inhibit_timer, Fig 7-8) the Carrier Sense Function is inhibited.
- (2) The MAU, upon waiting Tw (wait time) after the conclusion of output, activates as much of the signal quality error detecting mechanism as is possible without placing signals on the medium, thus sending the *signal_quality_error* message across the AUI for 10 ± 5 bit times ($10/BR \pm 5/BR$ seconds).
- (3) The DTE interprets the reception of the *signal_quality_error* message from the MAU as indication that the *signal_quality_error* detecting mechanism is operational and the *signal_quality_error* message may be both sent by the MAU and received by the DTE.

NOTES: (1) The occurrence of multiple (overlapping) transmitters on the medium during the time that the test window is open, as specified above, will satisfy the test and will verify proper operation of the signal quality error detecting mechanism and sending and receiving of the appropriate physical error message.

(2) If *signal_quality_error* exists at the DTE before CARRIER_OFF occurs, then the Collision Presence test sequence within the PLS as described in 7.2.4.3 above shall be aborted as shown in Fig 7-8.

7.3 Signal Characteristics

7.3.1 Signal Encoding. Two different signal encoding mechanisms may be used by the AUI. One of the mechanisms is used to encode data, the other to encode control.

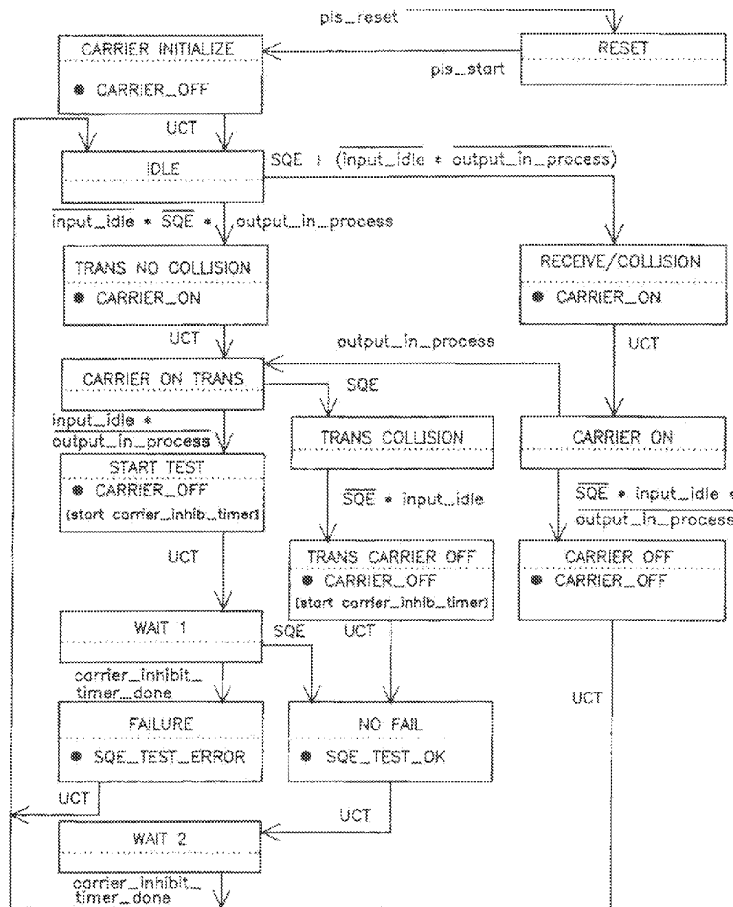

NOTE: UCT = unconditional transition
SQE = signal_quality_error

Fig 7-8
PLS Carrier Sense Function

7.3.1.1 Data Encoding. Manchester encoding is used for the transmission of data across the AUI. Manchester encoding is a binary signaling mechanism that combines data and clock into "bit-symbols." Each bit-symbol is split into two halves with the second half containing the binary inverse of the first half; a transition always occurs in the middle of each bit-symbol. During the first half of the bit-symbol, the encoded signal is the logical complement of the bit value being encoded. During the second half of the bit-symbol, the encoded signal is the uncomplemented value of the bit being encoded. Thus, a CD0 is encoded as a bit-symbol in which the first half is HI and the second half is LO. A CD1 is encoded as a bit-symbol in which the first half is LO and the second half is HI. Examples of Manchester waveforms are shown in Fig 7-10.

The line condition IDL is also used as an encoded signal. An IDL always starts with a HI signal level. Since IDL always starts with a HI signal, an additional transition will be added to the data stream if the last bit sent was a zero. This transition cannot be confused with clocked data (CD0 or CD1) since the transition will occur at the start of a bit cell. There will be no transition in the middle of the bit cell. The IDL

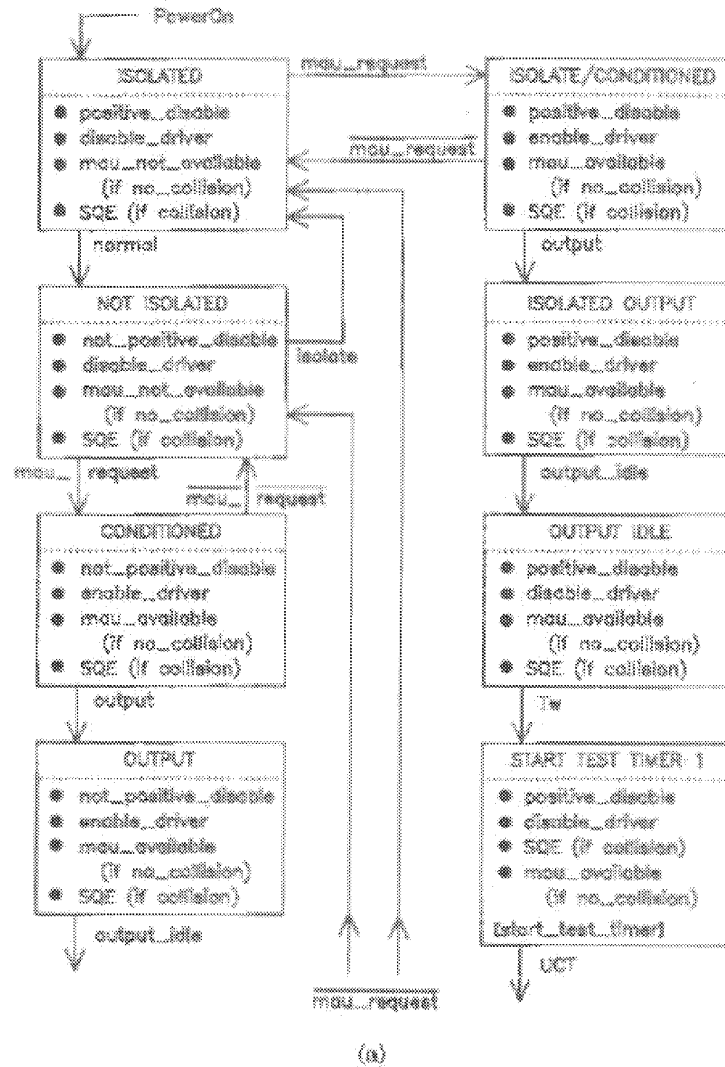

NOTE: See Figs 8-2 and 8-8 for simple and isolate type MAUs.

Fig 7-8
Interface Function for MAU with Conditioning

condition, as sent by a driver, shall be maintained for a minimum of 2 bit times. The IDL condition shall be detected within 1.6 bit times at the receiving device.

- (1) System jitter considerations make detection of IDL (etd, end transmission delimiter) earlier than 1.3 bit times impractical. The specific implementation of the phase-locked loop or equivalent clock recovery mechanism determines the lower bound on the actual IDL detection time. Adequate margin between lower bound and 1.6 bit times should be considered.
- (2) Recovery of timing implicit in the data is easily accomplished at the receiving side of the interface because of the wealth of binary transitions guaranteed to be in the encoded waveform, independent

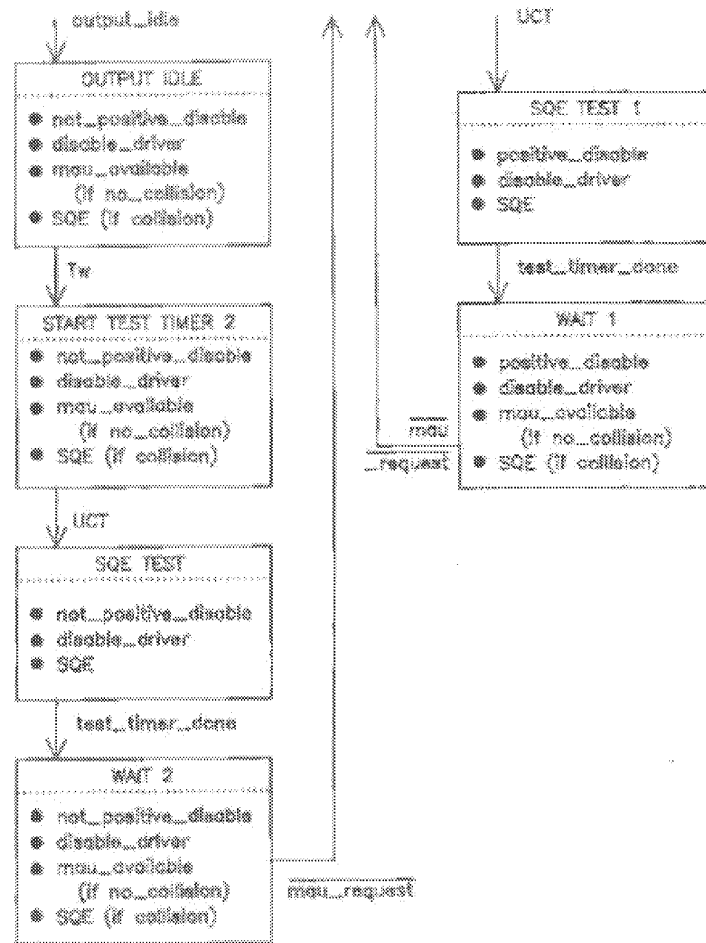

(b)

NOTE: See Figs 82 and 83 for simple and isolate type MAUs.

Fig 7-9
Interface Function for MAU with Conditioning

of the data sequence. A phase-locked loop or equivalent mechanism maintains continuous tracking of the phase of the information on the Data circuit.

7.3.1.2 Control Encoding. A simpler encoding mechanism is used for control signaling than for data signaling. The encoded symbols used in this signaling mechanism are CS0, CS1, and IDL. The CS0 signal is a signal stream of frequency equal to the bit rate (BR). The CS1 signal is a signal stream of frequency equal to half of the bit rate (BR/2). If the interface supports more than one bit rate (see 4.2), the bit rate in use on the data circuits is the one to which the control signals are referenced. The IDL signal used on the control circuits is the same as the IDL signal defined for the data circuits (see 7.3.1.1). The Control Out circuit is optional (O) as is one message on Control In.

The frequency tolerance of the CS1 and CS0 signals on the CO circuit shall be ±5% and that of the CS1 signal on the CI circuit shall be ±15%. The duty cycle of the above signals is nominally 50%/50% and shall

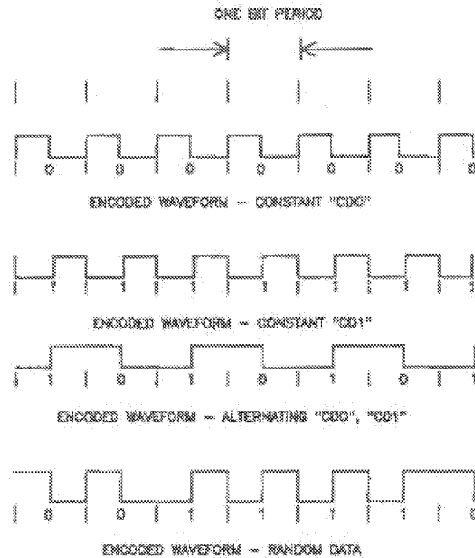

Fig 7-10
Examples of Manchester Waveforms

be no worse than 60%/40%. The CS0 signal on the CI circuit shall have a frequency tolerance of BR +25%, -15% with the pulse widths no less than 35 ns and no greater than 70 ns at the zero crossing points.

The meaning of the signals on the Control Out circuit (DTE to MAU) are:

Signal	Message	Description
IDL	<i>normal</i>	Instructs the MAU to enter (remain in) normal mode
CS1	<i>mau_request (0)</i>	Requests that the MAU should be made available
CS0	<i>isolate (0)</i>	Instructs the MAU to enter (remain in) monitor mode

The meaning of the signals on the Control In circuit (MAU to DTE) are:

Signal	Message	Description
IDL	<i>mau_available</i>	Indicates that the MAUs ready to output data
CS1	<i>mau_not_available</i>	Indicates that the MAU is not ready to output data
CS0	<i>signal_quality_error</i>	Indicates that the MAU has detected an error output data

7.3.2 Signaling Rate. Signaling rates of from 1 to 20 Mb/s are encompassed by this standard. This edition of the standard specifies a signaling rate of 10 million bits per second $\pm 0.01\%$.

It is intended that a given MDI operate at a single data rate. It is not precluded that specific DTE and MAU designs be manually switched or set to alternate rates. A given local network shall operate at a single signaling rate. To facilitate the configuration of operational systems, DTE and MAU devices shall be labeled with the actual signaling rate used with that device.

7.3.3 Signaling Levels. Exact voltage and current specifications are listed in 7.4.

7.4 Electrical Characteristics. Terms BR and BR/2 have very specific meaning as used in this subsection. The term BR is used to mean the bit rate of the highest signaling rate supported by any one implementation of this interface, BR/2 is used to mean half the bit rate of the lowest signaling rate supported by any one implementation of this interface (see 7.3.2). An interface may support one or more signaling rates.

NOTE: The characteristics of the driver and receiver can be achieved with standard ECL logic with the addition of an appropriate coupling network; however, this implementation is not mandatory.

7.4.1 Driver Characteristics. The driver is a differential driver capable of driving the specified 78 Ω interface cable. Only the parameters necessary to ensure compatibility with the specified receiver and to assure personnel safety at the interface connector are specified in the following sections.

7.4.1.1 Differential Output Voltage, Loaded. Drivers shall meet all requirements of this section under *two* basic sets of test conditions (that is, each of two resistive values). For drivers located within a DTE, a combined inductive load of 27 $\mu\text{H} \pm 1\%$ and either a 73 or 83 $\Omega \pm 1\%$ resistive load shall be used. For a driver located within a MAU, a combined inductive load of 50 $\mu\text{H} \pm 1\%$ and either 73 or 83 $\Omega \pm 1\%$ resistive load shall be used.

The differential output voltage, V_{dm} , is alternately positive and negative in magnitude with respect to zero voltage. The value of V_{dm} into either of the two test loads identified above ($R = 73 \Omega$ or $83 \Omega \pm 1\%$) at the interface connector of the driving unit shall satisfy the conditions defined by values V_1 , V_2 , and V_3 shown in Fig 7-11 for signals in between BR and BR/2 meeting the frequency and duty cycle tolerances specified for the signal being driven. The procedure for measuring and applying the test condition is as follows:

- (1) Measure the output voltage V_{dm} for the driver being tested at the waveform point after overshoot, before droop, under test load conditions of 7.4.1.1. This voltage is V_2 .
- (2) Calculate V_1 and V_3 .
- (3) V_1 shall be $< 1315 \text{ mV}$, V_3 shall be $> 450 \text{ mV}$.
- (4) The waveform shall remain within shaded area limits.

The differential output voltage magnitude, V_{dm} , into either of the two test loads identified above, at the interface connector of the driving unit during the idle state shall be within 40 mV of 0 V. The current into either of the two test loads shall be limited to 4 mA.

When a driver, connected to the appropriate two test loads identified above, enters the idle state, it shall maintain a minimum differential output voltage of at least $0.7 \times V_2$ mV for at least 2 bit times after the last low to high transition. The driver differential output voltage shall then approach within 40 mV of 0 V within 80 bit times. In addition, the current into the appropriate test load shall be limited in magnitude to 4 mA within 80 bit times. Undershoot, if any, upon reaching 0 V shall be limited to -100 mV . See Fig 7-12.

For drivers on either the CO or CI circuits, the first transition or the last positive going transition may occur asynchronously with respect to the timing of the following transitions or the preceding transition(s), respectively.

7.4.1.2 Requirements After Idle. When the driver becomes nonidle after a period of idle on the interface circuit, the differential output voltage at the interface connector shall meet the requirements of 7.4.1.1 beginning with the first bit transmitted. The first transition may occur asynchronously with respect to the timing of the following transitions.

7.4.1.3 AC Common-Mode Output Voltage. The magnitude of the ac component of the common-mode output voltage of the driver, measured between the midpoint of a test load consisting of a pair of matched 39 $\Omega \pm 1\%$ resistors and circuit VC, as shown in Fig 7-13, shall not exceed 40 mV peak.

7.4.1.4 Differential Output Voltage, Open Circuit. The differential output voltage into an open circuit, measured at the interface connector of the driving unit, shall not exceed 13 V peak.

7.4.1.5 DC Common-Mode Output Voltage. The magnitude of the dc component of the common-mode output voltage of the driver, measured between the midpoint of a test load consisting of a pair of matched 39 $\Omega \pm 1\%$ resistors and circuit VC, as shown in Fig 7-13, shall not exceed 5.5 V.

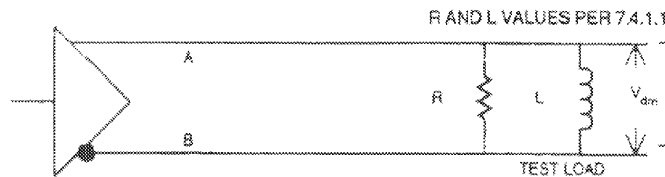
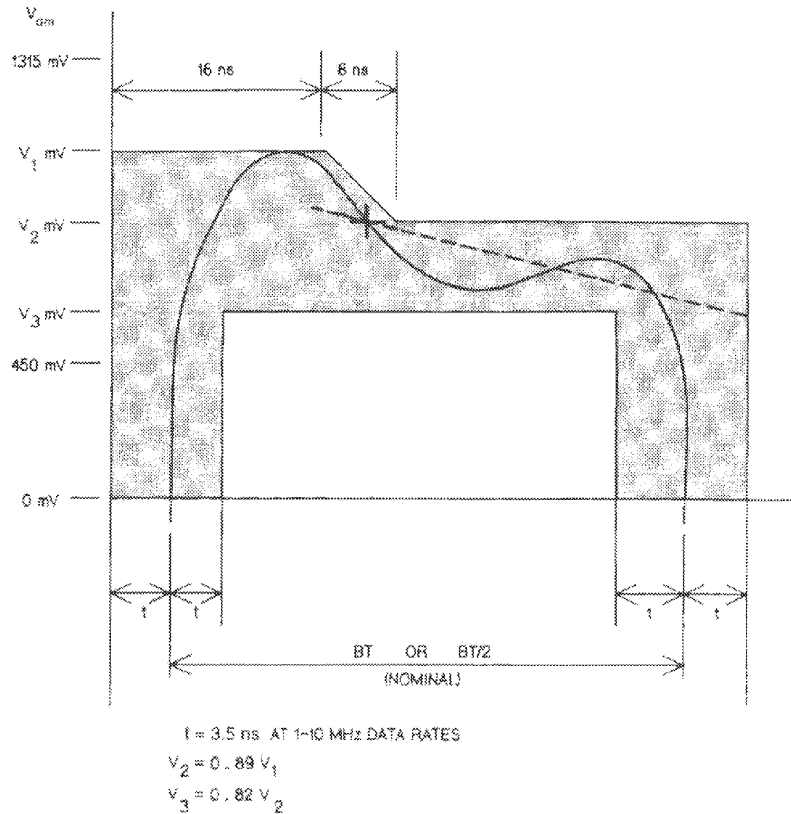

NOTE: The time t in this figure refers to the rise time envelope. Jitter and duty cycle are specified elsewhere.

Fig 7-11
Differential Output Voltage, Loaded

7.4.1.6 Fault Tolerance. Any single driver in the interface, when idle or driving any permissible signal, shall tolerate the application of each of the faults specified by the switch settings in Fig 7-14 indefinitely; and after the fault condition is removed, the operation of the driver, according to the specifications of 7.4.1.1 through 7.4.1.5, shall not be impaired.

In addition, the magnitude of the output current from either output of the driver under any of the fault conditions specified shall not exceed 150 mA.

7.4.2 Receiver Characteristics. The receiver specified terminates the interface cable in its characteristic impedance. The receiver shall function normally over the specified dc and ac common-mode ranges.

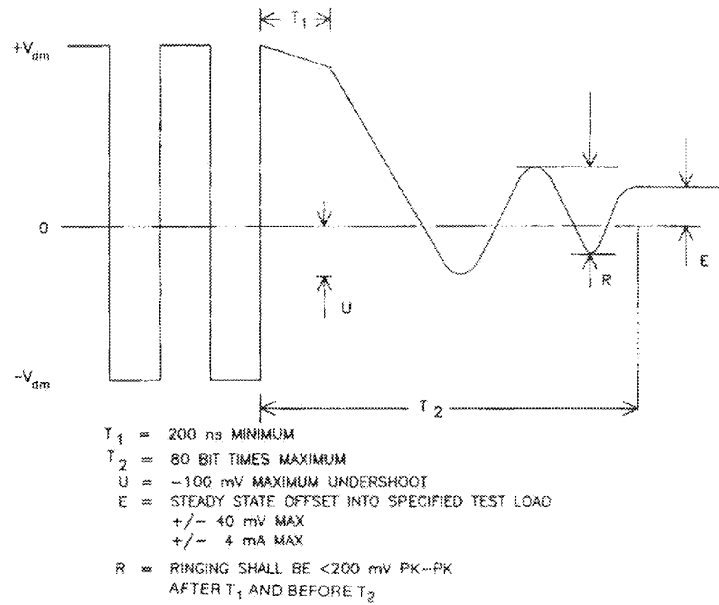

Fig 7-12
Generalized Driver Waveform

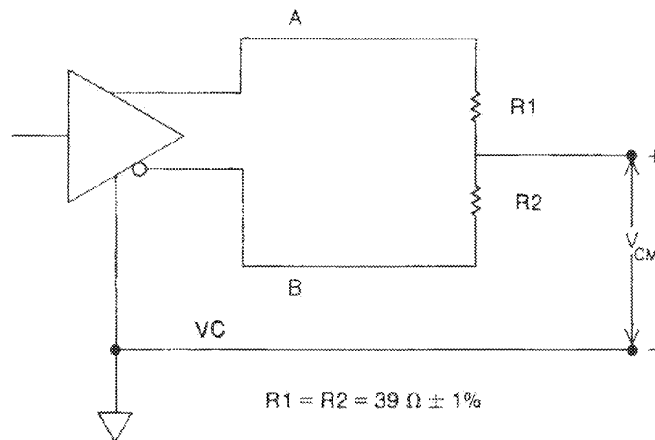

Fig 7-13
Common-Mode Output Voltage

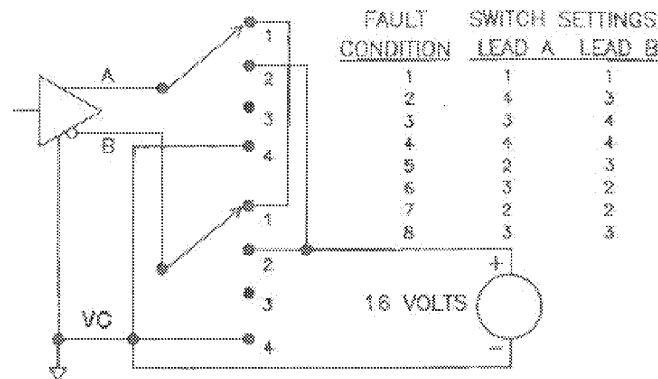

Fig 7-14
Driver Fault Conditions

7.4.2.1 Receiver Threshold Levels. When the receiving interface circuit at the interface connector of the receiving equipment is driven by a differential input signal at either BR or BR/2 meeting the frequency and duty cycle tolerances specified for the receiving circuit, when the A lead is 160 mV positive with respect to the B lead, the interface circuit is in the HI state, and when the A lead is 160 mV negative with respect to the B lead, the interface circuit is in the LO state. The receiver output shall assume the intended HI and LO states for the corresponding input conditions.

If the receiver has a squelch feature, the specified receive threshold levels apply only when the squelch is allowing the signal to pass through the receiver.

NOTE: The specified threshold levels do not take precedence over the duty cycle and jitter tolerance specified elsewhere. Both sets of specifications must be met.

7.4.2.2 AC Differential Input Impedance. The ac differential input impedance for AUI receivers located in MAUs shall have a real part of $77.83 \Omega \pm 6\%$, with the sign of the imaginary part positive, and the phase angle of the impedance in degrees less than or equal to 0.0338 times the real part of the impedance, when measured with a 10 MHz sine wave.

The ac differential input impedance for AUI receivers located in the DTE shall have a real part of $77.95 \Omega \pm 6\%$, with the sign of the imaginary part positive, and the phase angle of the impedance in degrees less than or equal to 0.0183 times the real part of the impedance, when measured with a 10 MHz sine wave.

A $78 \Omega \pm 6\%$ resistor in parallel with an inductance of greater than 27 μH or 50 μH for receivers in the MAU and DTE respectively, satisfies this requirement.

7.4.2.3 AC Common-Mode Range. When the receiving interface circuit at the receiving equipment is driven by a differential input signal at either BR or BR/2 meeting the frequency and duty cycle tolerances specified for the circuit being driven, the receiver output shall assume the proper output state as specified in 7.4.2.1, in the presence of a peak common-mode ac sine wave voltage either of from 30 Hz to 40 kHz referenced to circuit VC in magnitude from 0 to 3 V, or in magnitude 0 to 100 mV for ac voltages of from 40 kHz to BR as shown in Fig 7-15.

NOTE: The receiver shall also be able to reject small ac common-mode signals in frequencies outside of this range.

7.4.2.4 Total Common-Mode Range. When the receiving interface circuit at the receiving equipment is driven by a differential input signal at either BR or BR/2 meeting the frequency and duty cycle tolerances specified for the circuit being driven, the receiver output shall assume the intended output state as specified in 7.4.2.1 in the presence of a total common-mode voltage, dc plus ac, referenced to circuit VC in magnitude from 0 to 5.5 V, as shown in the test setup of Fig 7-15. The ac component shall not exceed the requirements of 7.4.2.3.

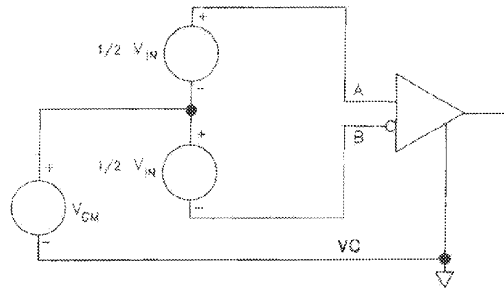

Fig 7-15
Common-Mode Input Test

The receiver shall be so designed that the magnitude of the current from the common-mode voltage source used in the test shall not exceed 1 mA.

7.4.2.5 Idle Input Behavior. When the receiver becomes nonidle after a period of idle on the interface circuit, the characteristics of the signal at the output of the receiver shall stabilize within the startup delay allowed for the device incorporating the receiver so that it is not prevented from meeting the jitter specifications established for that device.

The receiving unit shall take precautions to ensure that a HI to idle transition is not falsely interpreted as an idle to nonidle transition, even in the presence of signal droop due to ac coupling in the interface driver or receiver circuits.

7.4.2.6 Fault Tolerance. Any single receiver in the interface shall tolerate the application of each of the faults specified by the switch settings in Fig 7-16 indefinitely, and after the fault condition is removed, the operation of the receiver according to the specifications of 7.4.2.1 through 7.4.2.6 shall not be impaired.

In addition, the magnitude of the current into either input of the receiver under any of the fault conditions specified shall not exceed 3 mA.

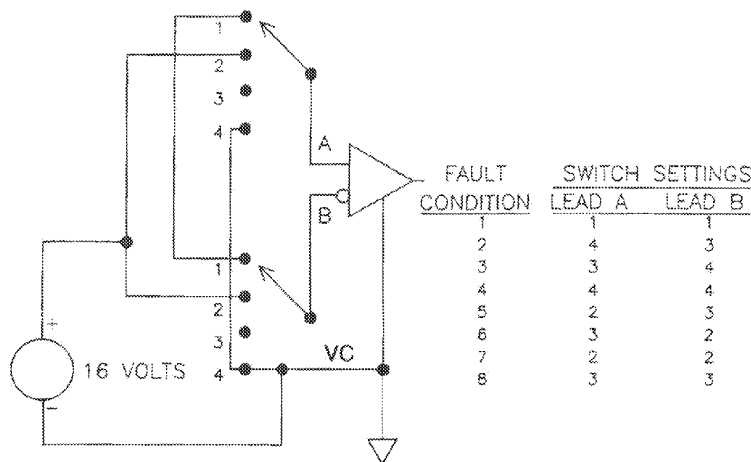

Fig 7-16
Receiver Fault Conditions

7.4.3 AUI Cable Characteristics. The interface cable consists of individually shielded twisted pairs of wires with an overall shield covering those individual shielded wire pairs. These shields must provide sufficient shielding to meet the requirements of protection against *rf* interference and the following cable parameters. Individual shields for each signal pair are electrically isolated from the outer shield but not necessarily from each other.

The overall shield shall be returned to the MAU and DTE Units via the AUI connector shell as defined in 7.6.2 and 7.6.3. If a common drain wire is used for all the signal pair shields, then it shall be connected to pin 4. Individual drain wire returns for each signal pair may be used (see 7.6.3). It is recommended that individual drain wires be used on all control and data circuit shields to meet satisfactory crosstalk levels. If individual drain wires are used, they shall be interconnected within the AUI cable at each end and shall be connected at least to pin 4 at each end of the cable.

The presence of the Control Out signal pair is optional. If driver or receiver circuit components for CO are not provided, consideration should be given to properly terminating the CO signal pair within the DTE and MAU to preclude erroneous operation.

7.4.3.1 Conductor Size. The dc power pair in the interconnecting cable, voltage common and voltage minus, shall be composed of a twisted pair of sufficient gauge stranded wires to result in a nominal dc resistance not to exceed 1.75 Ω per conductor.

Conductor size for the signal pairs shall be determined according to the ac related parameters in 7.4.3.2--7.4.3.6.

7.4.3.2 Pair-to-Pair Balanced Crosstalk. The balanced crosstalk from one pair of wires to any other pair in the same cable sheath (when each pair is driven per 7.4.1.1--7.4.1.5) shall have a minimum value of 40 dB of attenuation measured over the range of BR/2 to BR.

7.4.3.3 Differential Characteristic Impedance. The differential characteristic impedance for all signal pairs shall be equal within 3 Ω and shall be $78 \pm 5 \Omega$ measured at a frequency of BR.

7.4.3.4 Transfer Impedance

- (1) The common-mode transfer impedance shall not exceed the values shown in Fig 7-17 over the indicated frequency range.
- (2) The differential mode transfer impedance for all pairs shall be at least 20 dB below the common-mode transfer impedance.

7.4.3.5 Attenuation. Total cable attenuation levels between driver and receiver (at separate stations) for each signal pair shall not exceed 3 dB over the frequency range of BR/2 to BR (Hz) for sinewave measurements.

7.4.3.6 Timing Jitter. Cable meeting this specification shall exhibit edge jitter of no more than 1.5 ns at the receiving end when the longest legal length of the cable as specified in 7.4.3.1 through 7.4.3.7 is terminated in a $78 \Omega \pm 1\%$ resistor at the receiving end and is driven with pseudorandom Manchester encoded binary data from a data generator which exhibits no more than 0.5 ns of edge jitter on half bit cells of exactly 1/2 BT and whose output meets the specifications of 7.4.1.1 through 7.4.1.5. This test shall be conducted in a noise-free environment. The above specified component is not to introduce more than 1 ns of edge jitter into the system.

NOTE: Special attention will have to be applied to the cable characteristics and length at 20 Mbit/s.

7.4.3.7 Delay. Total signal delay between driver and receiver (at separate stations) for each signal pair shall not exceed 257 ns.

7.5 Functional Description of Interchange Circuits

7.5.1 General. The AUI consists of either three or four differential signal circuits, power, and ground. Two of the circuits carry encoded data and two carry encoded control information. Circuits DO (Data Out) and CO (Control Out) are sourced by the DTE, and circuits DI (Data In) and CI (Control In) are sourced by

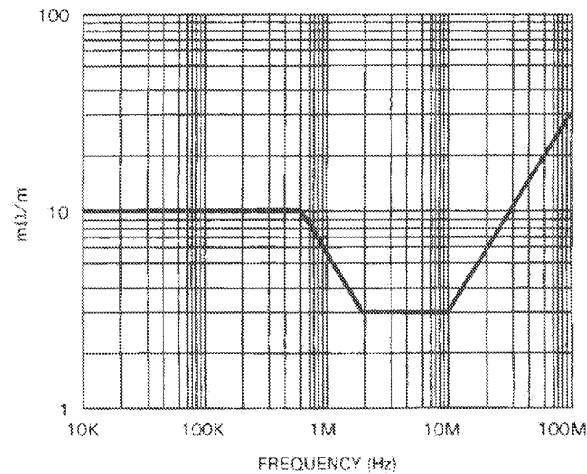

Fig 7-17
Common-Mode Transfer Impedance

the MAU. The interface also provides for power transfer from the DTE to the MAU. The CO circuit is optional.

7.5.2 Definition of Interchange Circuits. The following circuits are defined by this specification:

Circuit	Name	Signal Direction		Remarks
		to MAU	from MAU	
DO	Data Out	X		Encoded Data
DI	Data In		X	Encoded Data
CO	Control Out	X		Encoded Control
CI	Control In		X	Encoded Control
VP	Voltage Plus	X		12 Volts
VC	Voltage Common	X		Return for VP
PG	Protective Ground	X		Shield

7.5.2.1 Circuit DO-Data Out. The Data Out (DO) circuit is sourced by the DTE. It is a differential pair consisting of DO-A (Data Out circuit A) and DO-B (Data Out circuit B).

The signal transferred over this circuit is Manchester encoded. An *output* message containing a one bit is encoded as CD1. An *output_idle* message is encoded as an IDL.

The following symmetry requirements shall be met when the DTE transfers pseudo-random Manchester encoded binary data over a DO circuit loaded by the test load specified in 7.4.1.1.

Bit cells generated internal to the DTE are required to be 1 BT within the permitted tolerance on data rate specified in 7.3.2. Half bit cells in each data bit are to be exactly 1/2 BT (that is, the reference point for edge jitter measurements) within the permitted tolerance on the data rate specified in 7.3.2. Each transition on the DO circuit is permitted to exhibit edge jitter not to exceed 0.5 ns in each direction. This means that any transition may occur up to 0.5 ns earlier or later than this transition would have occurred had no edge jitter occurred on this signal.

7.5.2.2 Circuit DI—Data In. The Data In (DI) circuit is sourced by the MAU. It is a differential pair consisting of DI-A (Data In circuit A) and DI-B (Data In circuit B).

The signal transferred over this circuit is Manchester encoded. An *input* message containing a zero bit is encoded as CDO. An *input* message containing a one bit is encoded as CDI. An *input_idle* message is encoded as an IDL.

A DTE meeting this specification shall be able to receive, on the DI circuit without a detectable FCS error, normal preamble data arranged in legal length packets as sent by another station to the DTE. The test generator for the data on the DI circuit shall meet the requirements for drivers in MAUs specified in 7.4.1.1 through 7.4.1.5 and shall drive the DI circuit through a zero length AUI cable. Random amounts of edge jitter from 0 to 12 ns on either side of each transition shall be added by the test generator to transitions in bits in the preamble, and random amounts of edge jitter of from 0 to 18 ns on either side of each transition shall be added to the transitions in all bits in the frame. Preamble length from the test generator shall be 47 bits of preamble, followed by the 8 bit SFD.

NOTE: A significant portion of the system jitter may be nonrandom in nature and consists of a steady-state shift of the midbit transitions in either direction from their nominal placement. A 16.8 ns edge jitter is expected on the transmitted signal of the receiving DTE, worst case. The difference between 16.5 ns and 19 ns jitter represents receiver design margin.

7.5.2.3 Circuit CO—Control Out (Optional). The Control Out (CO) circuit is sourced by the DTE. It is a differential pair consisting of CO-A (Control Out circuit A) and CO-B (Control Out circuit B).

The signal transferred over this circuit is encoded as described in 7.3.1.2. A *max_request* message is encoded as CS1. A *normal* message is encoded as IDL. An *isolate* message is encoded as CS0.

7.5.2.4 Circuit CI—Control In. The Control In (CI) circuit is sourced by the MAU. It is a differential pair consisting of CI-A (Control In circuit A) and CI-B (Control In circuit B).

The signal transferred over this circuit is encoded as described in 7.3.1.2. A *max_available* message is encoded as IDL. A *max_not_available* message is encoded as CS1. A *signal_quality_error* message is encoded as a CS0.

7.5.2.5 Circuit VP—Voltage Plus. The Voltage Plus (VP) circuit is an optional circuit that may be sourced from the DTE. If this circuit is sourced from the DTE it shall be capable of operating at one fixed level between + 12 V dc \pm 6% and + 15 V dc \pm 6% with respect to circuit VC for all currents from 0 to 500 mA. The source shall provide protection for this circuit against an overload condition. The method of overload protection is not specified; however, under no conditions of operation, either normal or overload, shall the source apply a voltage to circuit VP of less than 0 or greater than + 15.75 V dc as specified above. MAU designers are cautioned that protection means employed by power sources may cause the voltage at signal VP to drop below the minimum operational voltage specified without going completely to zero volts when loads drawing in excess of the current supplied are applied between VP and VC. Adequate provisions shall be made to ensure that such a condition does not cause the MAU to disrupt the medium.

If the DTE does not support circuit VP, it shall have no connection to this circuit.

7.5.2.6 Circuit VC—Voltage Common. Circuit VC is the ground return to the power source for circuit VP, capable of sinking 2.0 A. Also, all common-mode terminators for AUI circuits shall be made to circuit VC.

7.5.2.7 Circuit PG—Protective Ground. Circuit PG shall be connected to chassis ground through a maximum dc resistance of 20 m Ω at the DTE end.

7.5.2.8 Circuit Shield Terminations. Individual pin terminations shall meet the following requirements:

- (1) Pins 1, 4, 8, 11, 14 connected to logic ground in the DTE
- (2) Pins 1, 4, 8, 11, 14 capacitively coupled to VC in MAU
- (3) Impedance to ground < 5 Ω at the lowest operational BR/2 in the MAU and at the highest BR in the DTE

7.6 Mechanical Characteristics

7.6.1 Definition of Mechanical Interfaces. All connectors used shall be as specified in 7.6.2. The DTE shall have a female connector and the MAU shall have a male connector. The MAU may be plugged directly into the DTE or may be connected by one or more cable segments whose total length is less than or equal to 50 m. All cable segments shall have a male connector on one end and a female connector on the other end. All female connectors shall have the slide latch, and all male connectors shall have the locking posts (as defined in Figs 7-18, 7-19, and 7-20) as the retention system.

7.6.2 Line Interface Connector. A 15-pole connector having the mechanical mateability dimensions as specified in IEC 807-2 [7] with gold-plated contacts shall be used for the line interface connector. The shells of these connectors shall be tin plated to ensure the integrity of the cable shield to chassis current path. The resistance of the cable shield to equipment chassis shall not exceed 5 mΩ, after a minimum of 500 cycles of mating and unmating.

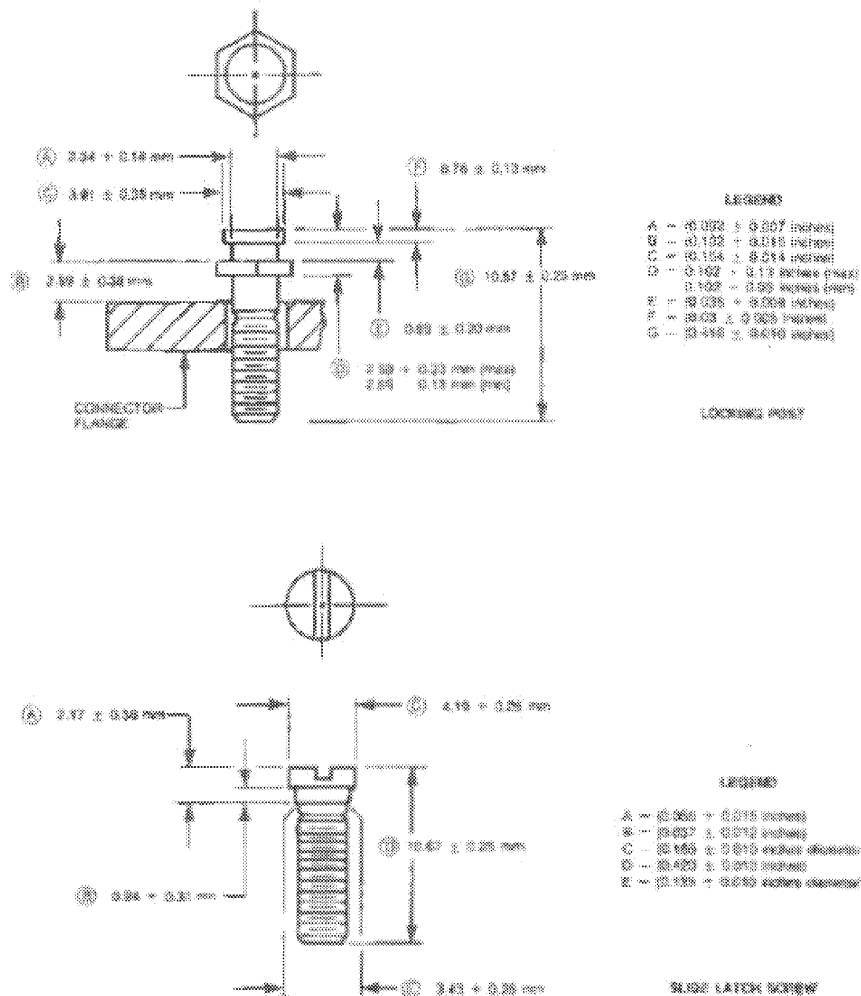

Fig 7-19
Connector Locking Posts

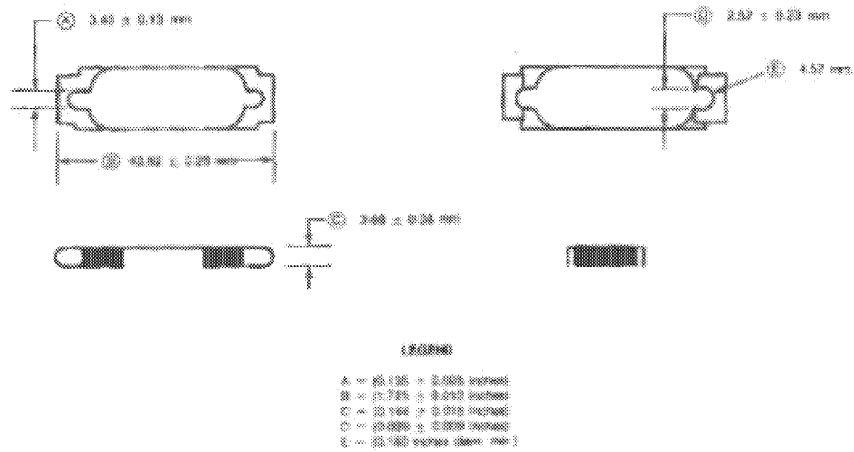

Fig 7-19
Connector Slide Latch

(material 24 gauge maximum)

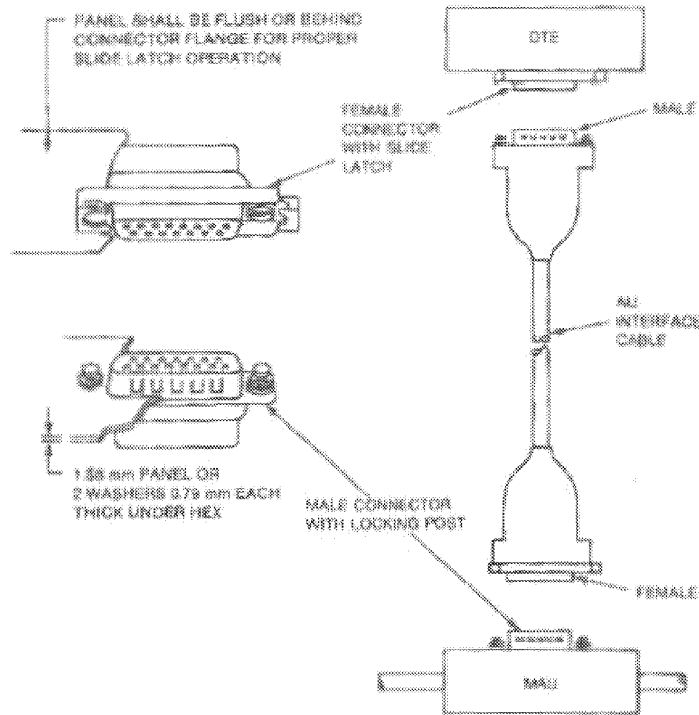

Fig 7-20
Connector Hardware and AUI Cable Configuration

In order to ensure interchangeability of connectors obtained from different manufacturers, the connector with female contacts shall conform to IEC 807-2 [7] and have gold-plated contacts and tin-plated shells. All additions to provide for female shell to male shell conductivity shall be on the shell of the connector with male contacts. There should be multiple contact points around the sides of this shell to provide for shield continuity.

NOTE: Use of similar metallic surfaces on connector conductors and similar metallic surfaces on the connector shells minimizes galvanic action and reduced performance.

The connector is not specified to prevent operator contact with the shield, and precautions shall be taken at installation time to ensure that the installer is warned that the shield is not to be brought into contact with any hazardous voltage while being handled by operating personnel.

See reference [A13].

7.8.3 Contact Assignments. The following table shows the assignment of circuits to connector contacts:

Contact	Circuit	Use
3	DO-A	Data Out circuit A
10	DO-B	Data Out circuit B
11	DO-S	Data Out circuit Shield
5	DI-A	Data In circuit A
12	DI-B	Data In circuit B
4	DI-S	Data In circuit Shield
7	CO-A	Control Out circuit A
15	CO-B	Control Out circuit B
8	CO-S	Control Out circuit Shield
2	CI-A	Control In circuit A
9	CI-B	Control In circuit B
1	CI-S	Control In circuit Shield
6	VC	Voltage Common
13	VP	Voltage Plus
14	VS	Voltage Shield
Shell	PG	Protection Ground (Conductive Shell)

NOTES: (1) Voltage Plus and Voltage Common use a single twisted pair in the AUI cable.

(2) As indicated in 7.4.2.1, the A lead of a circuit is positive relative to the B lead for a HI signal and negative for a LO signal.

8. Medium Attachment Unit and Baseband Medium Specifications, Type 10BASE5

8.1 Scope

8.1.1 Overview. This standard defines the functional, electrical, and mechanical characteristics of the MAU and one specific medium for use with local networks. The relationship of this specification to the entire ISO [IEEE] Local Network specification is shown in Fig 8-1. The purpose of the MAU is to provide a simple, inexpensive, and flexible means of attaching devices to the local network medium.

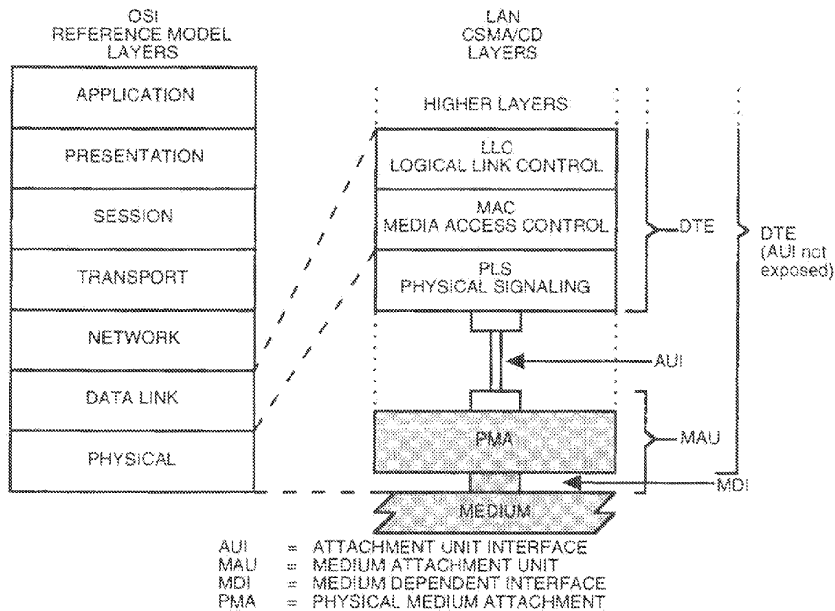

Fig 8-1
Physical Layer Partitioning, Relationship to the ISO Open Systems Interconnection (OSI) Reference Model

8.1.1.1 Medium Attachment Unit. The MAU has the following general characteristics:

- (1) Enables coupling the PLS by way of the AUI to the explicit baseband coaxial transmission system defined in this section of the standard.
- (2) Supports message traffic at a data rate of 10 Mb/s (alternative data rates may be considered in future additions to the standard).
- (3) Provides for driving up to 500 m (1640 ft) of coaxial trunk cable without the use of a repeater.
- (4) Permits the DTE to test the MAU and the medium itself.
- (5) Supports system configurations using the CSMA/CD access mechanism defined with baseband signaling.
- (6) Supports a bus topology interconnection means.

8.1.1.2 Repeater Unit. The repeater unit is used to extend the physical system topology, has the same general characteristics as defined in 8.1.1.1, and provides for coupling together two or more 500 m (1640 ft) coaxial trunk cable segments. Multiple repeater units are permitted within a single system to provide a maximum trunk cable connection path of 2.5 km (8200 ft) between any two MAUs.

8.1.2 Definitions

baseband coaxial system. A system whereby information is directly encoded and impressed on the coaxial transmission medium. At any point on the medium, only one information signal at a time can be present without disruption (see collision).

BR. The rate of data throughput (bit rate) on the medium in bits per second.

BR/2. One half of the BR in Hertz.

branch cable. The AUI cable interconnecting the DTE and MAU system components.

carrier sense. In a local area network, an ongoing activity of a data station to detect whether another station is transmitting.

NOTE: A collision presence signal is provided by the PLS to the PMA sublayer to indicate that one or more stations are currently transmitting on the trunk coaxial cable.

coaxial cable. A two-conductor (center conductor, shield system), concentric, constant impedance transmission line used as the trunk medium in the baseband system.

coaxial cable interface. The electrical and mechanical interface to the shared coaxial cable medium either contained within or connected to the MAU. Also known as MDI (Medium Dependent Interface).

coaxial cable segment. A length of coaxial cable made up from one or more coaxial cable sections and coaxial connectors, and terminated at each end in its characteristic impedance.

collision. An unwanted condition that results from concurrent transmissions on the physical medium.

collision presence. A signal provided by the PLS to the PMA sublayer (within the data link layer) to indicate that multiple stations are contending for access to the transmission medium.

compatibility interfaces. The MDI coaxial cable interface and the AUI branch cable interface, the two points at which hardware compatibility is defined to allow connection of independently designed and manufactured components to the baseband transmission system.

Medium Attachment Unit (MAU). In a local area network, a device used in a data station to couple the data terminal equipment to the transmission medium.

Medium Dependent Interface (MDI). The mechanical and electrical interface between the trunk cable medium and the MAU.

Physical Medium Attachment (PMA). The portion of the MAU that contains the functional circuitry.

Physical Signaling (PLS). That portion of the Physical Layer, contained within the DTE that provides the logical and functional coupling between MAU and Data Link Layers.

repeater. A device used to extend the length, topology, or interconnectivity of the physical medium beyond that imposed by a single segment, up to the maximum allowable end-to-end trunk transmission line length. Repeaters perform the basic actions of restoring signal amplitude, waveform, and timing applied to normal data and collision signals.

trunk cable. The trunk coaxial cable system.

8.1.3 Application Perspective: MAU and MEDIUM Objectives. This section states the broad objectives and assumptions underlying the specifications defined throughout this section of the standard.

8.1.3.1 Object

- (1) Provide the physical means for communication between local network data link entities.

NOTE: This standard covers a portion of the physical layer as defined in the OSI Reference Model and, in addition, the physical medium itself, which is beyond the scope of the OSI Reference Model.

- (2) Define a physical interface that can be implemented independently among different manufacturers of hardware and achieve the intended level of compatibility when interconnected in a common local network.
- (3) Provide a communication channel capable of high bandwidth and low bit error rate performance. The resultant mean bit error rate, at the physical layer service interface should be less than one part in 10^8 (on the order of one part in 10^9 at the link level).
- (4) Provide for ease of installation and service.
- (5) Provide for high network availability (ability of a station to gain access to the medium and enable the data link connection in a timely fashion).
- (6) Enable relatively low-cost implementations.

8.1.3.2 Compatibility Considerations. All implementations of this baseband coaxial system shall be compatible at the MDI.

This standard provides no explicit trunk cable medium specification for the interconnection of all MAU devices. The medium itself, the functional capability of the MAU, and the AUI are defined to provide the highest possible level of compatibility among devices designed by different manufacturers. Designers are free to implement circuitry within the MAU in an application-dependent manner provided the MDI interface and AUI specifications are satisfied.

Subsystems based on this specification may be implemented in several different ways provided compatibility at the medium is maintained. It is possible, for example, to design an integrated station where the MAU is contained within a physical DTE system component, thereby eliminating the AUI cable. The device designer (and system user) shall then consider such factors as topological flexibility, system availability, and configurability.

8.1.3.3 Relationship to PLS and AUI Interface. This section defines the primary physical layer for the local area network, a layer comprised of both the physical medium and the rudimentary circuitry necessary to couple a station's message path directly to/from the medium. The complete logical physical layer of the local area network may reside physically in two distinct locations, the MAU and the DTE. Therefore, a close relationship exists between this section and Section 7. This section specifies all of the physical medium parameters, all of the PMA logical functions residing in the physical MAU, and references the AUI associated with and defined throughout Section 7.

NOTE: The design of a physical MAU component requires the use of both this section and Section 7 for the PLS and AUI specifications.

8.1.3.4 Modes of Operation. The MAU is capable of operating in either a "Normal" mode or an optional "Monitor" mode.

- (1) *Normal Mode.* The MAU functions as a direct connection between the baseband medium and the DTE. Data output from the DTE is output to the coaxial trunk medium and all data on the coaxial trunk medium is input to the DTE. This mode is the "normal" mode of operation for the intended message traffic between stations.
- (2) *Monitor Mode.* The MAU Transmit Function is disabled to prevent data from being output on the trunk coaxial medium while the receive function and collision presence function remain active for purposes of monitoring medium message traffic. This mode also serves as a limited test mode at the same time it isolates the MAU transmitter from the medium. Under most local (that is, intrastation) fault conditions the monitor mode enables continued use of the network while the local station is being serviced.

8.2 MAU Functional Specifications. The MAU component provides the means by which signals on the four physically separate AUI signal circuits to/from the DTE and their associated interlayer messages are coupled to the single coaxial cable baseband signal line. To achieve this basic objective, the MAU compo-

nant contains the following functional capabilities to handle message flow between the DTE and the baseband medium:

- (1) *Transmit Function*. The ability to transmit serial data bit streams on the baseband medium from the local DTE entity and to one or more remote DTE entities on the same network.
- (2) *Receive Function*. The ability to receive serial data bit streams over the baseband medium.
- (3) *Collision Presence Function*. The ability to detect the presence of two or more stations' concurrent transmissions.
- (4) *Monitor Function* (Optional). The ability to inhibit the normal transmit data stream to the medium at the same time the normal receive function and collision presence function remain operational.
- (5) *Jabber Function*. The ability to automatically interrupt the transmit function and inhibit an abnormally long output data stream.

8.2.1 MAU Physical Layer Functions

8.2.1.1 Transmit Function Requirements. At the start of a frame transmission on the coaxial cable, no more than 2 bits (2 full bit cells) of information may be received from the DO circuit and not transmitted onto the coaxial medium. In addition, it is permissible for the first bit sent to contain encoded phase violations or invalid data; however, all successive bits of the frame shall be reproduced with no more than the specified amount of jitter. The second bit cell transmitted onto the coaxial cable shall be carried from the DO signal line and transmitted onto the coaxial trunk cable medium with the correct timing and signal levels. The steady-state propagation delay between the DO circuit receiver input and the coaxial cable output shall not exceed one-half bit cell. There shall be no logical signal inversions between the branch cable DO circuit and the coaxial trunk cable (for example, a "high" logic level input to the MAU shall result in the less negative current flow value on the trunk coaxial medium). A positive signal on the A signal lead of the DO circuit shall result in a more positive voltage level on the trunk coaxial medium. It is assumed that the ALI shall provide adequate protection against noise. It is recommended that the designer provide an implementation in which a minimum threshold signal is required to establish a transmit bit stream.

The Transmit Function shall output a signal on the trunk coaxial medium whose levels and waveform comply with 8.3.1.3.

In addition, when the DO circuit has gone idle after a frame is output, the MAU shall then activate the collision presence function as close to the trunk coaxial cable as possible without introducing an extraneous signal on the trunk coaxial medium. The MAU shall initiate the collision presence state within 0.6 μ s to 1.6 μ s after the start of the output idle signal and shall maintain an active collision presence state for a time equivalent to 10 ± 5 bit cells.

8.2.1.2 Receive Function Requirements. The signal from the coaxial trunk cable shall be directly coupled to the receiver and subsequently ac coupled before reaching the receive circuit connected to the DTE. The receive function shall output a signal onto the DI circuit of the AUI cable that complies with the AUI specification for drivers in MAUs.

At the start of a frame reception from the coaxial cable, no more than 5 bits (five full bit cells) of information may be received from the coaxial cable and not transmitted onto the receive (DI) circuit. In addition, it is permissible for the first bit sent over the receive circuit to contain encoded phase violations or invalid data; however, all successive bits of the frame shall reproduce the incoming signal with no more than the above specified amount of jitter. This implies that the second bit cell sent onto the DI circuit presents valid data to the branch cable. The steady-state propagation delay between the coaxial cable and the receive (DI) circuit output shall not exceed one-half bit cell. There are no logical signal inversions between the coaxial (trunk) cable and the MAU (branch) cable receive circuit. The circuit bandwidth of the receiver function shall be limited to 50 MHz.

A MAU meeting this specification shall exhibit edge jitter into the DI pair when terminated in the appropriate test load specified in 7.4.3.6, of no more than 8.0 ns in either direction when it is installed on the distant end of all lengths between 2.5 m and 500 m of the cable specified in 8.4.1.1 through 8.4.2.1.5 terminated at both ends with terminators meeting the impedance requirements of 8.5.2.1 and driven at one end with pseudo-random Manchester encoded binary data from a data generator that exhibits no more than 1.0 ns of edge jitter in either direction on half-bit cells of exactly 1/2 BT and whose output meets the specifications of 8.3.1.3 except that the risetime of the signal must be $30 \text{ ns} + 0, - 2 \text{ ns}$. This test shall be

conducted in a noise-free environment. The combination of coaxial cable and MAU receiver introduce no more than 6 ns of edge jitter into the system.

The local transmit and receive functions shall operate simultaneously while connected to the medium operating in the half duplex operating mode.

8.2.1.3 Collision Presence Function Requirements. The signal presented to the CI circuit in the absence of a collision shall be the IDL signal except when the MAU is required to signal the CS1 signal.

The signal presented to the CI circuit during the presence of a collision shall be the CS0 signals encoded as specified in 7.3.1.2. This signal shall be presented to the CI circuit no more than 9 bit times after the signal (for example, dc average) on the coaxial cable at the MAU equals or exceeds that produced by two (or more) MAU outputs transmitting concurrently under the condition that the MAU detecting collision presence is transmitting. Under no conditions shall the collision presence function generate an output when only one MAU is transmitting. A MAU, while not transmitting, may detect the presence of two other MAUs transmitting and shall detect the presence of more than two other MAUs transmitting. Table 8-1 summarizes the allowable conditions under which collisions shall be detected.

The collision presence function may, in some implementations, be able to sense an abnormal (for example, open) medium. The use of MAUs in repeaters requires added considerations; see 8.3.1.5.

Table 8-1
Generation of Collision Presence Signal

MAU	Numbers of Transmitters		
	<2	=2	>2
Transmitting	N	Y	Y
Not transmitting	N	May	Y
	Y	= will generate SQE message	
	N	= will not generate SQE message	
	May	= may generate SQE message	

8.2.1.4 Monitor Function Requirements (Optional). Upon receipt of the *isolate* message the MAU shall, within 20 ms (implementations: solid-state preferred, relay switched permitted), disable the transmit function in such a way as to prevent both the transmission of signals on the trunk coaxial medium and any abnormal loading by the disabled transmitter on the trunk coaxial medium itself. The monitor function is intended to prevent a malfunctioning active component (for example, transmit driver) from bringing down the network. The *isolate* message shall not interact with the receive or collision presence functions, thus permitting the normal operational mode wherein all data appearing on the trunk coaxial medium are carried to the DTE on the DI signal circuit.

NOTE: Verification for successful execution of the *isolate* message requires use of the trunk coaxial medium itself. This level of guaranteed performance requires use of system layers above the physical layer and implies some interruption of normal trunk coaxial medium message traffic.

8.2.1.5 Jabber Function Requirements. The MAU shall contain a self-interrupt capability to inhibit transmit data from reaching the medium. Hardware within the MAU (with no external message other than the detection of output data, bits, or leakage, by way of the transmit function) shall provide a nominal window of at least 20 ms to at most 150 ms during which time a normal data link frame may be transmitted. If the frame length exceeds this duration, the jabber function shall inhibit further output data from reaching the medium.

When the transmit function has been positively disabled, the MAU shall then activate the collision presence function as close to the trunk coaxial medium as possible without introducing an extraneous signal on the trunk coaxial medium. A MAU without the monitor function and powered by the DTE may reset the jabber and collision presence functions on power reset once the error condition has been cleared. Alternatively, a self-powered MAU may reset these functions after a period of 0.5 s \pm 50% if the monitor function has not been implemented. If the monitor function has been implemented then it shall be used to reset the collision presence and jabber functions.

8.2.2 MAU Interface Messages

8.2.2.1 DTE Physical Layer to MAU Physical Layer Messages. The following messages can be sent by the DTE physical layer entities to the MAU physical layer entities:

Message	Circuit	Signal	Meaning
<i>output</i>	DO	CD1, CD0	Output information
<i>output_idle</i>	DO	IDL	No data to be output
<i>normal</i>	CO	IDL	Assume the nonintrusive state on the trunk coaxial medium
(Optional Circuit)			
<i>isolate</i>	CO	CS0(BR)	Positively disable the trunk coaxial medium transmitter

8.2.2.2 MAU Physical Layer to DTE Physical Layer. The following messages can be sent by the MAU physical layer entities to the DTE physical layer entities:

Message	Circuit	Signal	Meaning
<i>input</i>	DI	CD1, CD0	Input information
<i>input_idle</i>	DI	IDL	No information to be input
<i>mau_available</i>	CI	IDL	MAU is available for output
<i>signal_quality_error</i>	CI	CS0	Error detected by MAU

8.2.2.2.1 *input* Message. The MAU physical layer sends an *input* message to the DTE physical layer when the MAU has a bit of data to send to the DTE. The physical realization of the *input* message is a CD0 or CD1 sent by the MAU to the DTE on the data in circuit. The MAU sends CD0 if the *input* bit is a zero or CD1 if the *input* bit is a one. No retiming of the CD1 or CD0 signals takes place within the MAU.

8.2.2.2.2 *input_idle* Message. The MAU physical layer sends an *input_idle* message to the DTE physical layer when the MAU does not have data to send to the DTE. The physical realization of the *input_idle* message is the IDL signal sent by the MAU to the DTE on the data in circuit.

8.2.2.2.3 *mau_available* Message. The MAU physical layer sends the *mau_available* message to the DTE physical layer when the MAU is available for output. The *mau_available* message is always sent by a MAU that is always prepared to output data unless the *signal_quality_error* message shall be sent instead. Such a MAU does not require *mau_request* to prepare itself for data output. The physical realization of the *mau_available* message is an IDL signal sent by the MAU to the DTE on the control in circuit.

8.2.2.2.4 *signal_quality_error* Message. The *signal_quality_error* message shall be implemented in the following fashion:

- (1) The *signal_quality_error* message shall not be sent by the MAU if no MAU or only one MAU is transmitting on the trunk coaxial medium in the normal mode.
- (2) If two or more remote MAUs are transmitting on the trunk coaxial medium, but the MAU connected to the local node is not transmitting, then the local MAU shall send the *signal_quality_error* message in every instance when it is possible for it to ascertain that more than one MAU is transmitting on the trunk coaxial medium. The MAU shall make the best determination possible. It is acceptable for the MAU to fail to send the *signal_quality_error* message when it is unable to conclusively determine that more than one MAU is transmitting.

- (3) When the local MAU is transmitting on the trunk coaxial medium, all occurrences of one or more additional MAUs transmitting shall cause the *signal_quality_error* message to be sent by the local MAU to its DTE.
- (4) When the MAU has completed each output frame it shall perform an SQE test sequence, as defined in Figs 8-2 and 8-3.
- (5) When the MAU has inhibited the transmit function it shall send the *signal_quality_error* message in accordance with the jabber function requirements of 8.2.1.5.

The *signal_quality_error* message shall be asserted less than 9 bit cells after the occurrence of the multiple-transmission condition is present at the MDI and shall no longer be asserted within 20 bit cells after the indication of multiple transmissions ceases to be present at the MDI. It is to be noted that an extended delay in the removal of the *signal_quality_error* message may affect adversely the access method performance.

The physical realization of the *signal_quality_error* message is the CS0 signal sent by the MAU to the DTE on the control in circuit.

Note that the MAU is required to assert the *signal_quality_error* message at the appropriate times whenever the MAU is powered and not just when the DTE is providing output data.

8.2.3 MAU State Diagrams. The state diagrams Figs 8-2, 8-3, and 8-4 depict the full set of allowed MAU state functions relative to the control circuits of the DTE-MAU interface for MAUs without conditioning requirements. Messages used in these state diagrams are explained below:

- (1) *positive_disable*. Activates the positive means provided in the MAU transmitter to prevent interference with the trunk coaxial medium.
- (2) *enable_driver*. Activates the path employed during normal operation to cause the MAU transmitter to impress data onto the trunk coaxial medium.
- (3) *disable_driver*. Deactivates the path employed during normal operation to cause the MAU transmitter to impress data onto the trunk coaxial medium.
- (4) *no_collision*. Signifies that the condition of multiple transmitters simultaneously active on the trunk coaxial medium does not exist.
- (5) *collision*. Signifies that the condition of multiple transmitters simultaneously active on the trunk coaxial medium does exist.
- (6) *not_positive_disable*. Deactivates the positive means provided in the MAU transmitter to prevent interference with the trunk coaxial medium.

8.3 MAU-Medium Electrical Characteristics

8.3.1 MAU-to-Coaxial Cable Interface. The following sections describe the interface between the MAU and the coaxial cable. Negative current is defined as current into the MAU (out of the center conductor of the cable).

8.3.1.1 Input Impedance. The shunt capacitance presented to the coaxial cable by the MAU circuitry (not including the means of attachment to the coaxial cable) is recommended to be no greater than 2 pF. The resistance to the coaxial cable shall be greater than 100 k Ω .

The total capacitive load due to MAU circuitry and the mechanical connector as specified in 8.5.3.2 shall be no greater than 4 pF.

These conditions shall be met in the power-off and power-on, not transmitting states (over the frequencies BR/2 to BR).

The magnitude of the reflection from a MAU shall not be more than that produced by a 4 pF capacitance when measured by both a 25 ns rise time and 25 ns fall time waveform. This shall be met in both the power on and power off, not transmitting states.

8.3.1.2 Bias Current. The MAU shall draw (from the cable) between + 2 μ A and - 25 μ A in the power-off and the power-on, not transmitting states.

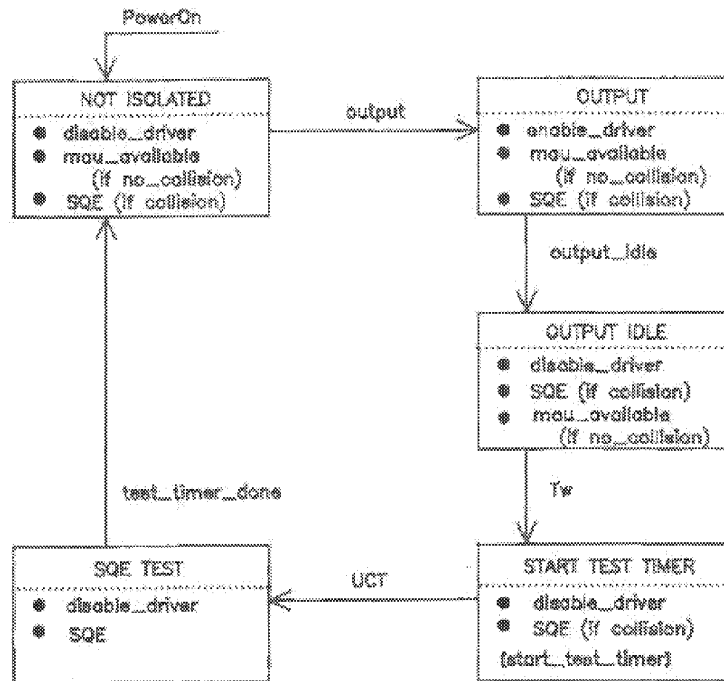

NOTE: UCT = unconditional transition
Tw = wait time, see 8.2.1.1

Fig 8-2
Interface Function: Simple MAU Without Isolate Capability

8.3.1.3 Coaxial Cable Signaling Levels: The signal on the coaxial cable due to a single MAU as measured at the MAU transmitter output is composed of an ac component and an offset component. Expressed in terms of current immediately adjacent to the MAU connection (just prior to splitting the current flow in each direction) the signal has an offset component (direct current including the effects of timing distortion) of from -37 mA minimum to -45 mA maximum and an ac component from +28 mA up to the offset value.

The current drive limit shall be met even in the presence of one other MAU transmitter. A MAU shall be capable of maintaining at least 2.2 V of average dc level on the coaxial cable in the presence of two or more other MAUs transmitting concurrently. The MAU shall, in addition, sink no more than ±250 µA when the voltage on the center conductor of the cable drops to -10 V when the MAU is transmitting.

The MAU shall sink no more than -25 µA when the voltage on the center conductor of the cable drops to -7 V when the MAU is transmitting.

The actual current measured at a given point on the cable is a function of the transmitted current and the cable loss to the point of measurement. Negative current is defined as current out of the center conductor of the cable (into the MAU). The 10-90% rise/fall times shall be 25 ± 5 ns at 10 Mb/s. The rise and fall times shall match within 2 ns. Figures 8-5 and 8-6 shows typical waveforms present on the cable. Harmonic content generated from the BR fundamental periodic input shall meet the following requirements:

- | | |
|------------------------|----------------------------------|
| 2nd and 3rd Harmonics: | at least 20 dB below fundamental |
| 4th and 5th Harmonics: | at least 30 dB below fundamental |
| 6th and 7th Harmonics: | at least 40 dB below fundamental |
| All Higher Harmonics: | at least 50 dB below fundamental |

NOTE: Even harmonics are typically much lower.

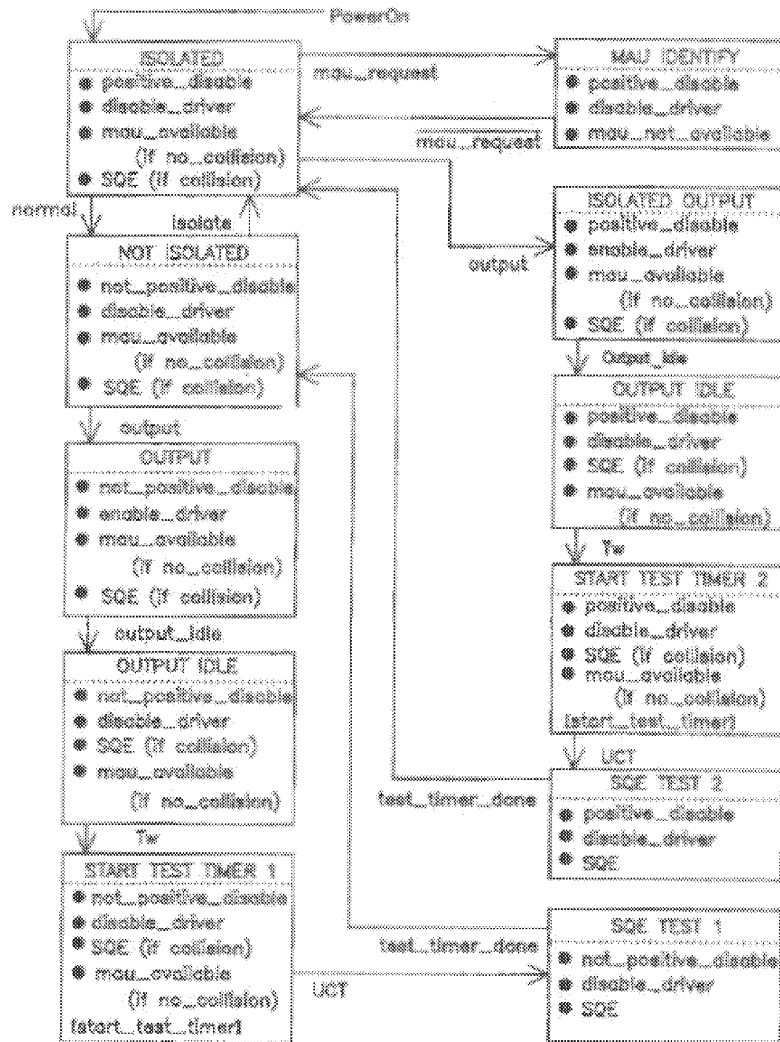

NOTE: UCT = Unconditional transition
Tw = wait time, see 8.2.1.1

Fig 8-3
Interface Function: Simple MAU with Isolate Capability

The above specifications concerning harmonics cannot be satisfied by a square-wave with a single-pole filter, nor can they be satisfied by an output waveform generator employing linear ramps without additional waveshaping. The signals as generated from the encoder within PLS shall appear on the coaxial cable without any inversions (see Fig 8-6).

8.3.1.4 Transmit Output Levels Symmetry. Signals received from the AUI DO circuit shall be transmitted onto the coaxial cable with the characteristics specified in 8.3.1.3. Since the coaxial cable proceeds in two directions from the MAU, the current into the MAU is nominally twice the current measured on the coaxial cable.

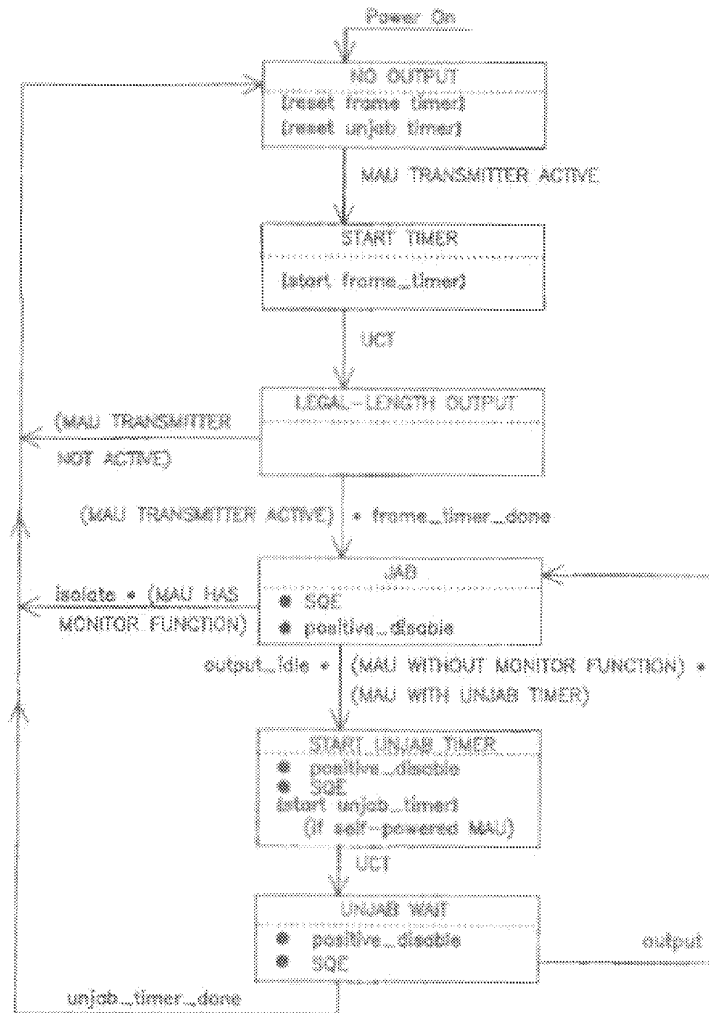

Fig 8-4
Jabber Function

The output signal of a MAU meeting this specification shall exhibit edge jitter of no more than 2.5 ns into a $25 \Omega \pm 1\%$ resistor substituted for the connection to the coaxial cable when the DO circuit into the MAU is driven through a zero length AUI cable with pseudorandom Manchester encoded binary data from a data generator that exhibits no more than 0.5 ns of edge jitter on half bit cells of exactly 1/2 BT whose output meets the specifications of 7.4.1.1 through 7.4.1.5. The above specified component is not to introduce more than 2 ns of edge jitter into the system.

The MAU shall not transmit a negative going edge after cessation of the CD output data stream on DO or before the first edge of the next frame on the DO circuit.

8.3.1.5 Receive Collision Detect Threshold. It is recommended that the MAU implement the collision detect function with a -1.492 V to -1.629 V threshold range corresponding to the recommended tolerances for coax drive currents specified in 8.3.1.3. The threshold voltage is measured on the coax at the MAU connector.

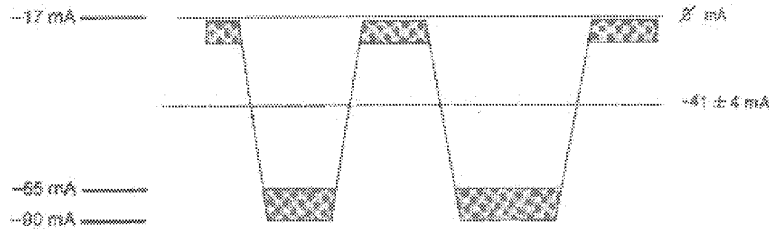
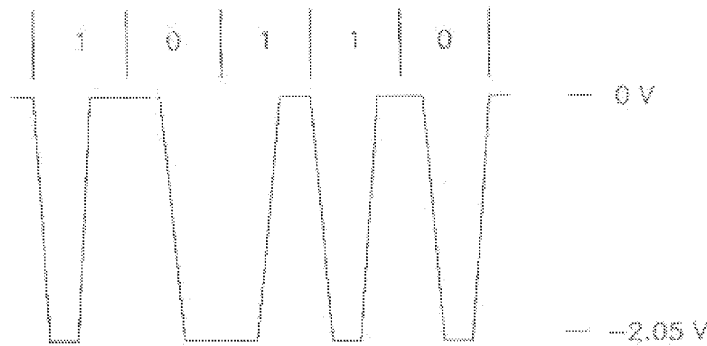

Fig 8-5
Recommended Driver Current Signal Levels



NOTES: (1) Voltages given are nominal, for a single transmitter.
(2) Rise and fall time is 25 ns nominal at 10 Mb/s rate.
(3) Voltages are measured on terminated coaxial cable adjacent to transmitting MAU.
(4) Manchester coding.

Fig 8-6
Typical Coaxial Trunk Cable Signal Waveform

Collision detection threshold voltages tighter than those recommended above may be used to improve collision detection performance in the presence of noise on the coax, poor system component tolerances, and coaxial transmit levels outside of the recommended range.

A MAU that implements the recommended receive threshold shall be considered to have implemented receive mode collision detect. Receive mode collision detect indicates that a nontransmitting MAU has the capability to detect collisions when two or more MAUs are transmitting simultaneously. Repeater units require both MAUs directly connected to it to implement receive mode collision detection.³

8.3.2 MAU Electrical Characteristics

8.3.2.1 Electrical Isolation. The MAU must provide isolation between the AUI cable and the coaxial trunk cable. The isolation impedance measured between each conductor (including shield) of the AUI cable and either the center conductor or shield of the coaxial cable shall be greater than 250 kΩ at 60 Hz and not greater than 15 Ω between 3 MHz and 30 MHz. The breakdown of the isolation means provided shall be at least 250 V ac, rms. See references [A7], [A8], and [A9].

³Repeater networks may require all MAU components to use the recommended coaxial drive connect levels. This matter is under consideration.

8.3.2.2 Power Consumption. The current drawn by the MAU shall not exceed 0.5 A as powered by the AUI source. The MAU shall be capable of operating from all possible voltage sources as supplied by the DTE through the resistance of all permissible AUI cables. The MAU shall not disrupt the trunk coaxial medium should the DTE power source fall below the minimum operational level under abnormal MAU load conditions.

The MAU shall be labeled externally to identify the maximum value of current required by the device at any specified input voltage.

8.3.2.3 Reliability. The MAU shall be designed to provide an MTBF of at least 1 million hours of continuous operation without causing communication failure among other stations attached to the local network medium. Component failures within the MAU electronics should not prevent communication among other MAUs on the coaxial cable. Connectors and other passive components comprising the means of connecting the MAU to the coaxial cable shall be designed to minimize the probability of total network failure.

It should be noted that a fault condition that causes a MAU to draw in excess of 2 mA may cause communication failure among other stations.

8.3.3 MAU-DTE Electrical Characteristics. The electrical characteristics for the driver and receiver components connected to the branch cable within the MAU shall be identical to those as specified in Section 7 of this standard.

8.3.4 MAU-DTE Mechanical Connection. The MAU shall be provided with a 15-pin male connector as specified in detail in the AUI specification, Section 7.

8.4 Characteristics of the Coaxial Cable. The trunk cable is of constant impedance, coaxial construction. It is terminated at each end by a terminator (see 8.5.2), and provides the transmission path for MAU device connection. Coaxial cable connectors are used to make the connection from the cable to the terminators, and between cable sections (if needed). The cable has various electrical and mechanical requirements that shall be met to ensure proper operation.

8.4.1 Coaxial Cable Electrical Parameters

8.4.1.1 Characteristic Impedance. The average characteristic cable impedance shall be $50 \pm 2 \Omega$, measured according to IEC Publications 96-1 [2] and 96-1A [3]. Periodic variations in impedance along a single piece of cable may be up to $\pm 3 \Omega$ sinusoidal centered around the average value, with a period of less than 2 m.

NOTE: If the requirements of 8.4.2.1.1 (2), 8.4.2.1.2, 8.4.2.1.3, 8.4.2.1.4 (3) are met, then it is expected that the characteristic impedance periodicity requirement shall be considered met.

8.4.1.2 Attenuation. The attenuation of a 500 m (1640 ft) cable segment shall not exceed 8.5 dB (17 dB/km) measured with a 10 MHz sine wave, nor 6.0 dB (12 dB/km) measured with a 5 MHz sine wave.

8.4.1.3 Velocity of Propagation. The minimum required velocity of propagation is 0.77 c.

8.4.1.4 Edge Jitter, Untapped Cable. Untapped coaxial cable meeting this specification shall exhibit edge jitter of no more than 8.0 ns in either direction at the receiving end when 500 m of the cable is terminated at both ends with terminators meeting the impedance requirements of 8.5.2.1 and is driven at one end with pseudorandom Manchester encoded binary data from a data generator that exhibits no more than 1.0 ns of edge jitter in either direction on half bit cells of exactly 1/2 BT and whose output meets the specifications of 8.3.1.3 except that the rise time of the signal must be $30 \text{ ns} + 0, - 2 \text{ ns}$, and no offset component in the output current is required. This test shall be conducted in a noise-free environment. The above specified component is not to introduce more than 7 ns of edge jitter into the system.

8.4.1.5 Transfer Impedance. The coaxial cable medium shall provide sufficient shielding capability to minimize its susceptibility to external noise and also to minimize the generation of interference by the medium and related signals. While the cable construction is not mandated, it is necessary to indicate a measure of performance expected from the cable component. A cable's EMC performance is determined, to a large extent, by the transfer impedance value of the cable. See reference [A12].

The transfer impedance of the cable shall not exceed the values shown in Fig 8-7 as a function of frequency.

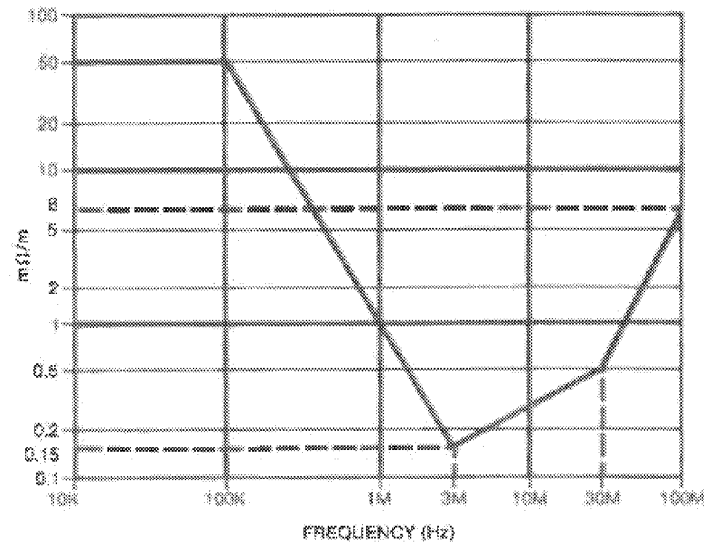

Fig 8-7
Maximum Coaxial Cable Transfer Impedance

8.4.1.6 Cable DC Loop Resistance. The sum of the center conductor resistance plus the shield resistance, measured at 20 °C, shall not exceed 10 mΩ/m.

8.4.2 Coaxial Cable Properties

8.4.2.1 Mechanical Requirements. The cable used should be suitable for routing in various environments, including but not limited to, dropped ceilings, raised floors, cable troughs, and throughout open floor space. The jacket shall provide insulation between the cable sheath and any building structural metal. Also, the cable shall be capable of accepting coaxial cable connectors, described in 8.5. The cable shall conform to the following requirements.

8.4.2.1.1 General Construction

- (1) The coaxial cable shall consist of a center conductor, dielectric, shield system, and overall insulating jacket.
- (2) The concentricity (for example, positional relationship between center conductor to shield system and outer jacket) of the coaxial cable elements shall be greater than 92% as measured in accordance with the following general configuration:

$$\frac{(\text{jacket radius}) - (\text{center offset})}{\text{jacket radius}} \times 100 \geq 92\%$$

It is assumed that the offset and radius values are worst case at any point within the measured system.

- (3) The coaxial cable jacket, shield system, and dielectric material shall be pierceable either by means of the connector type specified in 8.5.3.2 or by an external core tool. Overall cable system pierceability (the ability of a tap probe to pierce the jacket, shields, and dielectric cable system without

substantial dielectric deformation and without causing a short circuit between center conductor and shield system) is a vital parameter affecting tap connection reliability.

Pierceability of the cable system can be measured in terms of the probe's load versus displacement signature. A pierceable cable exists where the displacement is ≥ 1.52 mm (0.06 in) between rupture (piercing) of the shield system and contact with the center conductor.

- (4) The coaxial cable shall be sufficiently flexible to support a bend radius of 254 mm (10 in).

8.4.2.1.2 Center Conductor. The center conductor shall be 2.17 mm \pm 0.013 mm (0.0855 ± 0.0005 in) diameter solid copper.

8.4.2.1.3 Dielectric Material. The dielectric may be of any type provided the conditions of 8.4.1.2, 8.4.1.3, and 8.4.2.1.1(3) are met.

8.4.2.1.4 Shielding System

- (1) The shielding system may contain both braid and foil elements sufficient to meet the transfer impedance of 8.4.1.5 and the EMC specifications of 8.7.2.
- (2) The inside diameter of the innermost shield shall be 6.15 mm (0.242 in) minimum.
- (3) The outside diameter of the outermost shield shall be 8.28 mm \pm 0.178 mm (0.326 ± 0.007 in).
- (4) The outermost shield shall be greater than 90% coverage. The use of tinned copper braid is advised to meet the contact resistance requirements.

8.4.2.1.5 Overall Jacket

- (1) Any one of several jacket materials shall be used provided the specifications of 8.4.1 and 8.4.2 are met.
- (2) Either of two jacket dimensions may be used for the two broad classes of materials, provided the specification of 8.4.2.1.1 are met:
 - (a) Polyvinyl Chloride (for example, PVC) or equivalent having an OD of 10.287 mm \pm 0.178 mm (0.405 nominal \pm 0.007 in).
 - (b) Fluoropolymer (for example, FEP, E-CTFE) or equivalent having an OD of 9.525 mm \pm 0.254 mm (0.375 nominal \pm 0.010 in).

The cable shall meet applicable flammability and smoke criteria and local and national codes for the installed environment. See 8.7.4. Different types of cable sections (for example, polyvinyl chloride and fluoropolymer dielectric) may be interconnected, while meeting the sectioning requirements of 8.6. See references [A6] and [A14].

8.4.2.2 Jacket Marking. The cable jacket shall be marked with annular rings in a color contrasting with the background color of the jacket. The rings shall be spaced at 2.5 m \pm 5 cm regularly along the entire length of the cable. It is permissible for the 2.5 m spacing to be interrupted at discontinuities between cable sections joined by connectors. (See 8.6.2.2 for MAU placement rules that mandate cable markings.) It is recommended that the base color of the cable jacket itself be a bright color (for example, yellow) other than that normally used for power mains.

8.4.3 Total Segment DC Loop Resistance. The sum of the center conductor, connectors, and shield resistance shall not exceed 5Ω total per segment.

Each in-line connector pair or MAU shall be no more than 10 m Ω . Use of these components reduces the overall allowable segment length accordingly. Values given above are at 20°C . For temperature variations, cable length shall be adjusted accordingly such that the 5Ω total is not exceeded.

If a trunk coaxial cable segment consists of several cable sections, then all connectors and internal resistance of the shield and center conductor shall be included in the loop resistance measurement.

8.5 Coaxial Trunk Cable Connectors. The trunk coaxial medium requires termination and may be extended or partitioned into sections. Devices to be attached to the medium as MAUs require a means of connection to the medium. Two basic connector types provide the necessary connection means:

- (1) Standard Type N connectors (IEC Publication 169-16 [4])
- (2) A coaxial "tap" connector

All Type N connectors shall be of the 50 Ω constant impedance type. Since the frequencies present in the transmitted data are well below UHF range (being band-limited to approximately 20 MHz), high-quality versions of the connectors are not required (but are recommended).

All of the coaxial tap connectors shall follow the requirements as defined in 8.5.3.

8.5.1 Inline Coaxial Extension Connector. All coaxial cables shall be terminated with the Type N plug connectors. A means shall be provided to ensure that the connector shell (which connects to the cable sheath) does not make contact with any building metal or other unintended conductor. An insulating sleeve or boot slipped over the connector at installation time is suitable.

In-line coaxial extensions between two sections of coaxial cable shall be made with a pair of Type N receptacle connectors joined together to form one "barrel." An insulating sleeve or boot shall also be provided with each barrel assembly.

8.5.2 Coaxial Cable Terminator

8.5.2.1 Termination. Coaxial cable terminators are used to provide a termination impedance for the cable equal in value to its characteristic impedance, thereby minimizing reflection from the ends of the cables. Terminators shall be packaged within an in-line female receptacle connector. The termination impedance shall be 50 $\Omega \pm 1\%$ measured from 0 – 20 MHz, with the magnitude of the phase angle of the impedance not to exceed 5°. The terminator power rating shall be 1 W or greater.

8.5.2.2 Earthing. Either the coaxial cable terminator or in-line extension connector provides a convenient location for meeting the earth grounding requirement of 8.6.2.3. It is recommended that a ground lug with current rating of at least 1500 ampacity be provided on one of the two terminators or on one extension connector used within a cable segment.

NOTES: (1) A single ground return lug on an in-line connector located in the center of the cable transmission system may be used to satisfy this requirement.

(2) Alternatively, terminators might be supplied in pairs, one with and one without the ground lug connection point.

8.5.3 MAU-to-Coaxial Cable Connection. A means shall be provided to allow for attaching a MAU to the coaxial cable. The connection shall not disturb the transmission line characteristics of the cable significantly; it shall present a predictably low shunt capacitance, and therefore a negligibly short stub length. This is facilitated by the MAU being located as close to its cable connection as possible; the MAU and connector are normally considered to be one assembly. Long (greater than 50 mm) connections between the coaxial cable and the input of the MAU jeopardize this objective.

Overall system performance is dependent largely on the MAU-to-coaxial cable connection being of low shunt capacitance.

If the design of the connection is such that the coaxial cable is to be covered to install the MAU, the coaxial cable segment shall still meet the sectioning requirements of 8.6.2.1. Coaxial connectors used on a severed cable shall be type N, as specified in 8.5.1.

The type N connectors selected should be of high quality (that is, low contact resistance) to minimize the impact on system performance.

If the design of the connection is such that the piercing tap connector is to be used without covering the cable, then the tap connector and cable assembly shall conform to the mechanical and electrical requirements as defined throughout 8.5.3.1 and 8.5.3.2.

8.5.3.1 Electrical Requirements. Requirements for the coaxial tap connector are as follows:

- (1) Capacitance: 2 pF nominal connector loading measured at 10 MHz.

NOTE: Total capacitance of tap and active circuitry connected directly shall be no greater than 4 pF. Specific implementations may allocate capacitance between tap and circuitry as deemed appropriate.

- (2) Contact resistance (applies to center conductor and shield contacts): 50 m Ω maximum for both shield and center conductor over useful connector lifetime.

- (3) Contact material: surface material on signal probe or shield sufficient to meet contact resistance requirements in environment and over time.
- (4) Voltage rating: 600 V dc or ac rms maximum.
- (5) Insulation: dc leakage resistance of tap housing shall be higher than 1 GΩ between braid and external conductors in the normal operating environment.
- (6) Probe current rating: 0.1 A per contact (probe and shield)
- (7) Shield current rating: 1 A surge for 1 s

8.5.3.2 Mechanical Requirements

8.5.3.2.1 Connector Housing. Shielding characteristics: > 40 dB at 50 MHz.

8.5.3.2.2 Contact Reliability. Overall performance of the LAN system depends to a large extent on the reliability of the coaxial cable medium and the connection to that medium. Tap connection systems should consider the relevant electrical and mechanical parameters at the point of electrical connection between tap probe and cable center conductor to ensure that a reliable electrical contact is made and retained throughout the useful life of these components. It is recommended that some means be provided to ensure relatively constant contact loading over time, with creep, in temperature, and typical environment. Typical coaxial tap connector configurations are shown in Figs 8-8 and 8-9. See references [A1], [A15], and [A16].

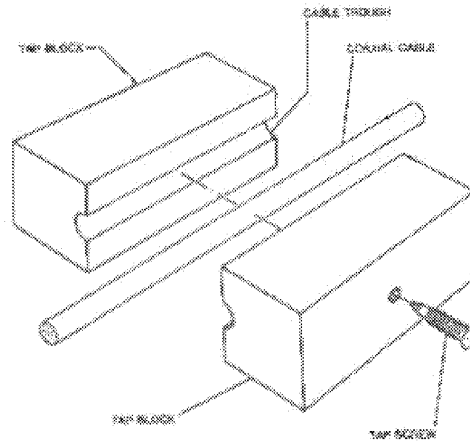

NOTE: Tutorial only and not part of specification

Fig 8-8
Coaxial Tap Connector Configuration Concepts

8.5.3.2.3 Shield Probe Characteristics. The shield probe shall penetrate the cable jacket and outer layer(s) of the shield system to make effective capture of the outer braid (pick 2 or more typical strands).

8.6 System Considerations

8.6.1 Transmission System Model. Certain physical limits have been placed on the physical transmission system. These revolve around maximum cable lengths (or maximum propagation times), as these affect critical time values for the CSMA/CD access method. These maxima, in terms of propagation times, were derived from the physical configuration model described here. The maximum configuration is as follows:

- (1) A trunk coaxial cable, terminated in its characteristic impedance at each end, constitutes a coaxial segment. A coaxial segment may contain a maximum of 500 m of coaxial cable and a maximum of

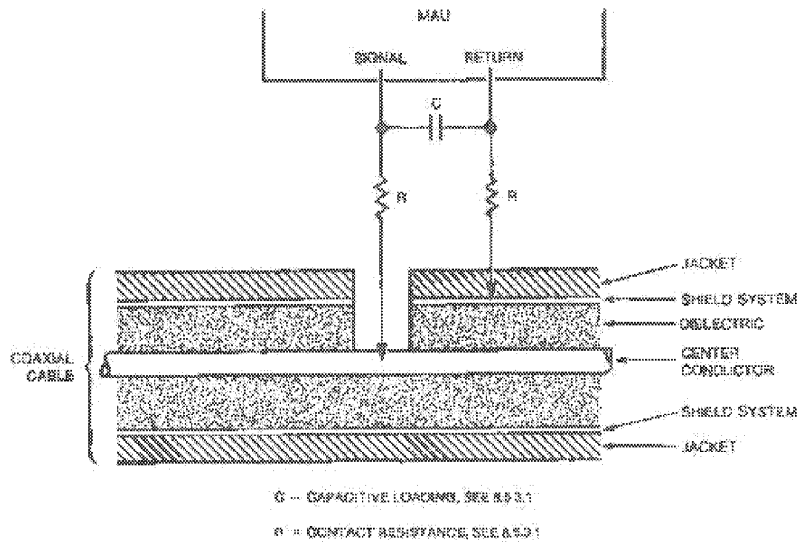

Fig 8-9
Typical Coaxial Tap Connection Circuit

- 100 MAUs. The propagation velocity of the coaxial cable is assumed to be 0.77 c minimum ($c = 300\,000$ km/s). The maximum end-to-end propagation delay for a coaxial segment is 2165 ns.
- (2) A point-to-point link constitutes a link segment. A link segment may contain a maximum end-to-end propagation delay of 2570 ns.
 - (3) Repeater sets are required for segment interconnection. Repeater sets occupy MAU positions on coaxial segments and count toward the maximum number of MAUs on a coaxial segment. Repeater sets may be located in any MAU position on a coaxial segment but shall only be located at the ends of a link segment.
 - (4) The maximum length, between driver and receivers, of an AUI cable is 30 m. The propagation velocity of the AUI cable is assumed to be 0.65 c minimum. The maximum allowable end-to-end delay for the AUI cable is 257 ns.
 - (5) The maximum transmission path permitted between any two stations is five segments, four repeater sets (including optional AUIs), two MAUs, and two AUIs. Of the five segments a maximum of three may be coaxial segments; the remainder are link segments.

NOTE: If only two link segments are used in the entire network and they are adjacent, the repeater set joining them is not required (see Fig 8-10). End-to-end jitter, propagation delay, and attenuation requirements shall still be met.

The maximum transmission path consists of 5 segments, 4 repeater sets (with AUIs), 2 MAUs, and 2 AUIs (see Fig 8-10). The total number of segments equals the number of link segments plus the number of coaxial segments. If there are two link segments on the transmission path, there may be a maximum of three coaxial segments on that path. If there are no link segments on a transmission path, there may be a maximum of three coaxial segments on that path given current repeater technology.

Figures 8-11, 8-12, 8-13, and 8-14 show transmission systems of various sizes to illustrate the boundary conditions on topologies generated according to the specifications in this section.

8.6.2 Transmission System Requirements

8.6.2.1 Cable Sectioning. The 500 m (1640 ft) maximum length coaxial cable segment need not be made from a single, homogeneous length of cable. The boundary between two cable sections (joined by coaxial connectors: two male plugs and a barrel) represents a signal reflection point due to the impedance discontinuity caused by the batch-to-batch impedance tolerance of the cable. Since the worst-case variation from 50 Ω is 2 Ω , a possible worst-case reflection of 4% may result from the joining of two cable sections.

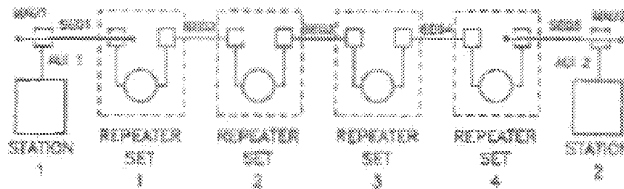

Fig 8-10
Maximum Transmission Path

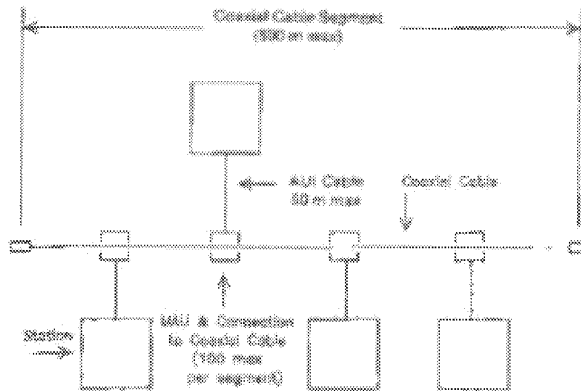

Fig 8-11
Minimal System Configuration

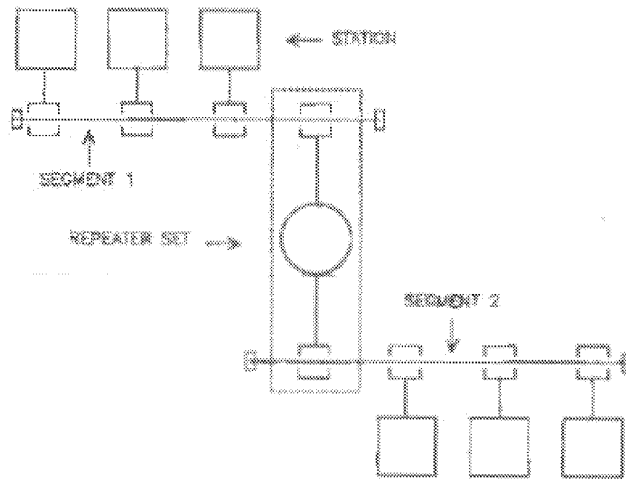

Fig 8-12
Minimal System Configuration Requiring a Repeater Set

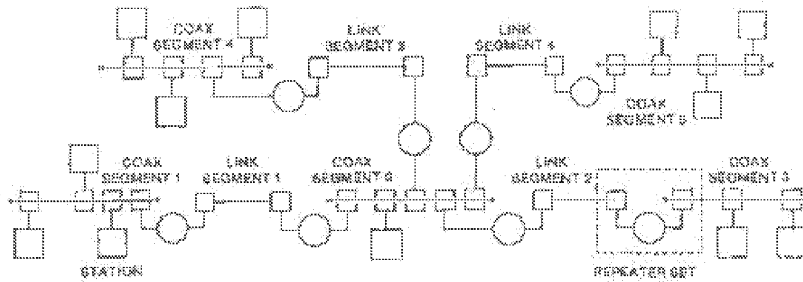

Fig 8-13
An Example of a Large System with Maximum Transmission Paths

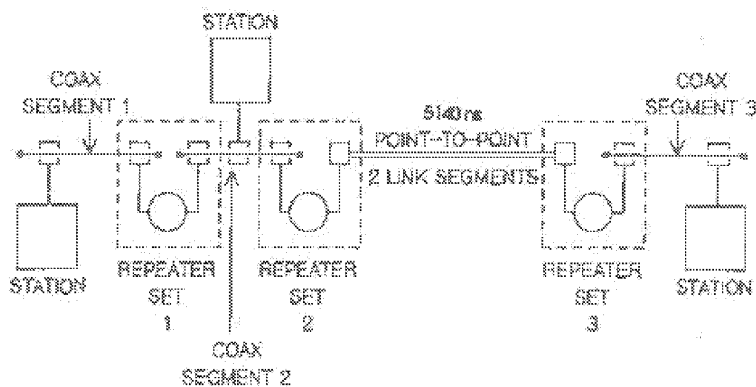

Fig 8-14
An Example of a Large Point-to-Point Link System (5140 ns)

The configuration of long cable segments (up to 500 m) from smaller sections must be made with care. The following *recommendations* apply, and are given in *order of preference*:

- (1) If possible, the total segment should be made from one homogeneous (no breaks) cable. This is feasible for short segments, and results in minimal reflections from cable impedance discontinuities.
- (2) If cable segments are built up from smaller sections, it is recommended that all sections come from the same manufacturer and lot. This is equivalent to using a single cable, since the cable discontinuities are due to extruder limitations, and not extruder-to-extruder tolerances. There are no restrictions in cable sectioning if this method is used. However, if a cable section in such a system is later replaced, it shall be replaced either with another cable from the same manufacturer and lot, or with one of the standard lengths described below.
- (3) If uncontrolled cable sections must be used in building up a longer segment, the lengths should be chosen so that reflections, when they occur, do not have a high probability of adding in phase. This can be accomplished by using lengths that are odd integral multiples of a half wavelength in the cable at 5 MHz; this corresponds to using lengths of 23.4 m, 70.2 m, and 117 m (± 0.5 m) for all sections. These are considered to be the standard lengths for all cable sections. Using these lengths exclusively, any mix or match of cable sections may be used to build up a 500 m segment without incurring excessive reflections.

NOTE: If cable segments are to be added to existing installations, then care should be taken (explicit physical or TDR measurements) to ensure that no more than a 500 m cable segment results.

- (4) As a last resort, an arbitrary configuration of cable sections may be employed, if it has been confirmed by analysis or measurement that the worst-case signal reflection due to the impedance discontinuities at any point on the cable does not exceed 7% of the incident wave when driven by a MAU meeting these specifications.

8.6.2.2 MAU Placement. MAU components and their associated connections to the cable cause signal reflections due to their noninfinite bridging impedance. While this impedance shall be implemented as specified in Section 7, placement of MAUs along the coaxial cable must also be controlled to ensure that reflections from the MAU do not add in phase to a significant degree.

Coaxial cables marked as specified in 8.4.2.2 have marks at regular 2.5 m spacing; a MAU shall only be placed at a mark on the cable. This guarantees both a minimum spacing between MAUs of 2.5 m, and controlling the relative spacing of MAUs to ensure nonalignment on fractional wavelength boundaries.

The total number of MAUs on a cable segment shall not exceed 100.

8.6.2.3 Trunk Cable System Grounding. The *shield conductor* of each coaxial cable segment shall make electrical contact with an effective earth reference (see Annex) at one point and shall not make electrical contact with earth elsewhere on such objects as building structural metal, ducting, plumbing fixture, or other unintended conductor. Insulators may be used to cover any coaxial connectors used to join cable sections and terminators, to ensure that this requirement is met. A sleeve or boot attached at installation time is acceptable.

This specification is intended for use within (intraplant) buildings. Applications requiring interplant connections by way of external (outdoors) means may require special consideration beyond the scope of the standard.

The sheath conductor of the AUI cable shall be connected to the earth reference or chassis of the DTE.

8.6.3 Labeling. It is recommended that each MAU (and supporting documentation) be labeled in a manner visible to the user with at least these parameters:

- (1) Data rate capability in Mb/s
- (2) Power level in terms of maximum current drain
- (3) Safety warning (for example, shock hazard)

8.7 Environmental Specifications

8.7.1 General Safety Requirements. All stations meeting this standard shall conform to one of the following IEC Publications: 380 [5], 435 [6], or 950 [8].

NOTE: For ISO/IEC 8802-3:1993, conformance shall be to IEC 950 [8].

8.7.2 Network Safety Requirements. This section sets forth a number of recommendations and guidelines related to safety concerns, the list is neither complete nor does it address all possible safety issues. The designer is urged to consult the relevant local, national, and international safety regulations to ensure compliance with the appropriate standards. References [A5] and [A9] provide additional guidance.

Local area network trunk cable systems as described in this standard are subject to at least four direct electrical safety hazards during their use. These hazards are

- (1) Direct contact between local network components and power or lighting circuits.
- (2) Static charge buildup on local network cables and components.
- (3) High-energy transients coupled onto the local network cabling system.
- (4) Potential differences between safety grounds to which various network components are connected.

These electrical safety hazards, to which all similar cabling systems are subject, should be alleviated properly for a local network to perform properly. In addition to provisions for properly handling these faults in an operational system, special measures must be taken to ensure that the intended safety features are not negated during installation of a new network or during modification of an existing network.

Proper implementation of the following provisions will greatly decrease the likelihood of shock hazards to persons installing and operating the local area network.

8.7.2.1 Installations. Sound installation practice, as defined by applicable local codes and regulations, shall be followed in every instance in which such practice is applicable.

8.7.2.2 Grounding. The shield of the trunk coaxial cable shall be effectively grounded at only one point along the length of the cable. Effectively grounded means permanently connected to earth through a ground connection of sufficiently low impedance and having sufficient ampacity to prevent the building up of voltages that may result in undue hazard to connected equipment or to persons.

8.7.2.3 Safety. All portions of the trunk cabling system that are at the same potential as the trunk cable shall be insulated by adequate means to prevent their contact by either persons or by unintended conductors or grounds. The insulation employed shall provide the same or greater dielectric resistance to current flow as the insulation required between the outermost shield of the trunk cable and the above-mentioned unintended conductors. The use of insulating boots is permitted, provided that such boots (or sleeves) are mechanically and electrically equivalent to the trunk cable outer insulation characteristics and are not removed easily (that is, they shall prevent inadvertent removal by a system operator).

The MAU shall be so designed that the provisions of 8.7.2.3 and 8.7.2.4 are not defeated if the connector affixing the AUI cable to the MAU is removed.

Portions of the trunk cabling system that may become live during the dissipation of a high-energy transient by the cabling system shall also be insulated as described in 8.7.2.3.

8.7.2.4 Breakdown Path. MAUs meeting this standard should provide a controlled breakdown path that will shunt high-energy transients to an effective ground either through a separate safety ground connection or through the overall shield of the branch cable. The breakdown voltage of this controlled breakdown path must meet the isolation requirements for the MAU specified in 8.3.2.1.

8.7.2.5 Isolation Boundary. The isolation boundary between the branch cable and trunk cable specified in 8.3.2.1 shall be maintained to properly meet the safety requirements of this standard.

WARNING: It is assumed that the DTE equipment is properly earthed and not left floating or serviced by "doubly insulated ac power distribution system." The use of floating or insulated DTEs is beyond the scope of this standard.

8.7.2.6 Installation and Maintenance Guidelines

- (1) When exposing the shield of the trunk coaxial cable for any reason, care shall be exercised to ensure that the shield does not make electrical contact with any unintended conductors or grounds. Personnel performing the operation should not do so if dissipation of a high energy transient by the cabling system is likely during the time the shield is to be exposed. Personnel should not contact both the shield and any grounded conductor at any time.
- (2) Before breaking the trunk coaxial cable for any reason, a strap with ampacity equal to that of the shield of the coaxial cable shall be affixed to the cable shield in such a manner as to join the two pieces and to maintain continuity when the shield of the trunk cable is severed. This strap shall not be removed until after normal shield continuity has been restored.
- (3) At no time should the shield of any portion of the coaxial trunk cable to which an MAU or MAUs are attached be permitted to float without an effective ground connection. If a section of floating cable is to be added to an existing cable system, the installer shall take care not to complete the circuit between the shield of the floating cable section and the grounded cable section through body contact.
- (4) The installation instructions for network components shall contain language which familiarizes the installer with the cautions mentioned in the above paragraphs.
- (5) Network components shall contain prominent warning labels that refer installers and service personnel to the safety notes in the installation instructions.

8.7.3 Electromagnetic Environment

8.7.3.1 Susceptibility Levels. Sources of interference from the environment include electromagnetic fields, electrostatic discharge, transient voltages between earth connections, and similar interference. Mul-

multiple sources of interference may contribute to voltage buildup between the coaxial cable and the earth connection of a DTE.

The physical channel hardware shall meet its specifications when operating in either of the following conditions:

- (1) Ambient plane wave field of 2 V/m from 10 kHz through 30 MHz, 5 V/m from 30 MHz through 1 GHz.

NOTE: Levels typically 1 km from broadcast stations.

- (2) Interference voltage of 1 V/ns peak slope, between coaxial cable shield and DTE earth connection; for example, 15.8 V peak for a 10 MHz sine wave with a 50 Ω source resistance.

MAUs meeting this standard should provide adequate rf ground return to satisfy the referenced EMC specifications.

8.7.3.3 Emission Levels. The physical MAU and trunk cable system shall comply with applicable local and national codes such as FCC Docket 20780-1980 [A11] in the USA. Equipment shall comply with local and national requirements for limitation of electromagnetic interference. Where no local or national requirements exist, equipment shall comply with CISPR Publication 22 [1].

8.7.4 Temperature and Humidity. The MAU and associated connector/cable systems are expected to operate over a reasonable range of environmental conditions related to temperature, humidity, and physical handling such as shock and vibration. Specific requirements and values for these parameters are considered to be beyond the scope of this standard. Manufacturers are requested to indicate in the literature associated with the MAU (and on the MAU if possible) the operating environment specifications to facilitate selection, installation, and maintenance of these components. See reference [A10] for specification terminology.

8.7.5 Regulatory Requirements. The design of MAU and medium components should take into consideration applicable local or national requirements. See references [A5], [A6], [A7], [A8], [A9], and [A11] and Appendix A for helpful resource material.¹⁰

¹⁰Appendix A provides useful system guidelines on delays and bit budgets.

9. Repeater Unit for 10 Mb/s Baseband Networks

9.1 Overview. This section specifies a repeater for use with type 10BASE5, 10BASE2, and 10BASE-T networks and fiber optic inter-repeater links (FOIRLs). A repeater for any other ISO 8802-3 network type is beyond the scope of this section.

A repeater set connects segments of network medium together, thus allowing larger topologies and a larger MAU base than are allowed by rules governing individual segments (that is, for 10BASE5, 500 m and 100 stations; for 10BASE2, 185 m and 30 stations; for 10BASE-T, nominal 100 m link segment).

Repeater sets are used to extend the network length and topology beyond what could be achieved by a single coaxial segment, as defined in 8.6 or 10.7. Segments may be connected directly by a repeater set (Fig 9-1) or by pairs of repeater units which are, in turn, connected by inter-repeater links (IRLs). Allowable topologies shall contain only one operative signal path between any two points on the network. A maximum of four repeater sets may be in the signal path between any two stations on the network (this assumes two link segments).

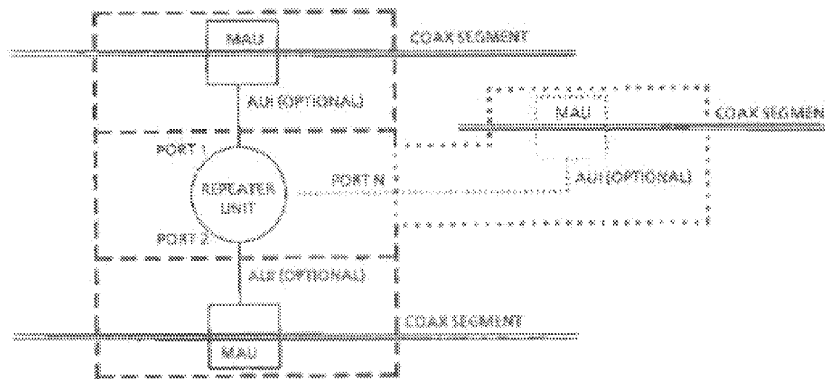

NOTE: The ALI is not necessarily exposed when the MAU is, optionally, part of the physical repeater.

Fig 9-1
Repeater Set, Coax-to-Coax Configuration

If the repeater set uses MAUs connected via ALIs to a repeater unit, the external MAUs shall be basic MAUs with the exception of the *signal_quality_error* test function. A manufacturer may, optionally, integrate one or all MAUs into a single package with the repeater unit (internal MAUs). In all cases, the MAU portion of the repeater set must be counted toward the maximum number of MAUs on each segment, as specified in 8.6 and 10.7. A repeater set is not a station and does not count toward the overall limit of 1024 stations on a network.

A repeater set can receive and decode data from any segment under worst-case noise, timing, and signal amplitude conditions. It retransmits the data to all other segments attached to it with timing and amplitude restored. The retransmission of data occurs simultaneously with reception. If a collision occurs, the repeater set propagates the collision event throughout the network by transmitting a Jam signal.

9.2 Definitions

data frame. Consists of the Destination Address, Source Address, Length Field, LLC Data, Pad, and Frame Check Sequence.

Fiber Optic Medium Attachment Unit (FOMAU). The portion of the physical layer between the FOMDI and AUI (or repeater unit physical layer signaling [PLS] when the AUI is not implemented) which contains the electronics that transmit, receive, and manage the encoded signals impressed on, and recovered from, the optical fiber cable link segment.

Fiber Optic Medium-Dependent Interface (FOMDI). The mechanical and optical interface between the optical fiber cable link segment and the FOMAU.

Fiber Optic Physical Medium Attachment (FOPMA). The portion of the FOMAU that contains the functional circuitry.

FOIRL BER. Mean bit error rate of the FOIRL.

FOIRL Collision. Simultaneous transmission and reception of data in a FOMAU.

FOIRL Compatibility Interfaces. The FOMDI and the AUI (optional); the two points at which hardware compatibility is defined to allow connection of independently designed and manufactured components to the baseband optical fiber cable link segment.

FOMAU's Transmit Optical Fiber. The optical fiber into which the local FOMAU transmits signals.

FOMAU's Receive Optical Fiber. The optical fiber from which the local FOMAU receives signals.

IRL (Inter-Repeater Link). A mechanism for interconnecting two and only two repeater units.

link segment. The point-to-point full duplex medium connection between two and only two Medium-Dependent Interfaces (MDIs).

optical fiber. A filament-shaped optical waveguide made of dielectric materials.

Optical Fiber Cable Interface. See FOMDI.

Optical Fiber Cable Link Segment. A length of optical fiber cable that contains two optical fibers, as specified in 9.9.5.1, and is comprised of one or more optical fiber cable sections and their means of interconnection, with each optical fiber terminated at each end in the optical connector plug specified in 9.9.5.2.

Optical Idle Signal. The signal transmitted by the FOMAU into its transmit optical fiber during the idle state of the DO circuit.

Packet. Consists of a data frame as defined previously, preceded by the Preamble and the Start Frame Delimiter.

port. A segment or IRL interface of a repeater unit.

repeater unit. The portion of a repeater set that is inboard of its PMA/PLS interfaces.

repeater set. A repeater unit plus its associated MAUs and, if present, AU Interfaces (AUIs).

9.3 References. See 1.3.

9.4 Compatibility Interface. The repeater shall attach to its network segments by any of the means specified below.

9.4.1 AUI Compatibility. The repeater unit shall be compatible at its AUI connector (if so equipped) as specified in Section 7 with the exception of the *signal_quality_error* message Test, 7.2.1.2.3, which shall not be implemented.

The MAUs associated with the repeater shall be as specified in Section 8 for type 10BASE5 or Section 10 for type 10BASE2 with the following restrictions:

- (1) The MAU shall implement receive mode collision detect as defined in 8.3.1.5 or 10.4.1.5.
- (2) The MAU shall not implement the *signal_quality_error* message Test function as defined in 8.2.1.1 and 10.3.1.1.
- (3) The MAU shall not activate its Jabber function when operated under the worst-case Jabber Lockup Protection condition as specified in 9.6.5.

MAUs associated with the repeater unit shall be as specified in Section 14 for type 10BASE-T with the restriction that the MAU shall not perform the *signal_quality_error* message Test function as defined in 14.2.1.5.

9.4.2 Direct Coaxial Cable Compatibility. The repeater set, which includes MAUs integrated with the repeater package (internal MAUs), may have any of the interfaces specified in the following subsections.

9.4.2.1 Direct Cable Attachment Compatibility. The repeater shall be compatible at its coaxial tap connector (if so equipped) as specified in 8.5.3 of the 10BASE5 standard. The MAUs associated with the repeater that are connected in this manner shall be subject to the restrictions of MAUs as specified in 9.4.1.

9.4.2.2 "N" Connector Compatibility. The repeater shall be compatible at its Type N connector (if so equipped) as specified in 8.5. The MAUs associated with the repeater that are connected in this manner shall be subject to the restrictions of MAUs as specified in 9.4.1.

9.4.2.3 BNC Compatibility. The repeater shall be compatible at its BNC connector (if so equipped) as specified in 10.6. The MAUs associated with the repeater that are connected in this manner shall be subject to the restrictions of MAUs as specified in 9.4.1.

9.4.3 Link Segment Compatibility. The compatibility interfaces for link segments including IRL segments are either vendor-dependent, as specified in 9.4.3.1, or are vendor-independent MDI, as defined in the remainder of this section.

9.4.3.1 Vendor-Dependent IRL. The budget allowances for the topology supported by the IRL shall ensure that the total network round-trip delay requirement is met and the maximum collision frame size of 511 bits is not exceeded. (See 8.6.1 and 10.7.1.)

9.4.3.2 Vendor-Independent FOIRL. A vendor-independent FOIRL provides a standard means of connecting two repeater units. It comprises a fiber optic medium link segment, a FOMAU at each end of the link segment, and if present, AU Interfaces. A vendor-independent FOIRL is suitable for interconnecting coaxial segments, especially segments located in different buildings.

The vendor-independent FOMAU should be compatible at its FOMDI, as specified in 9.9. If a FOMAU contains an AU Interface, it shall be electrically and mechanically compatible at its AUI connector as specified in Section 7, with the exception of the *signal_quality_error* message Test, 7.2.1.2.3, which shall not be implemented.

9.4.3.3 Twisted-Pair Jack Compatibility. The repeater set shall be compatible at its 8-pin modular jack (if so equipped), as specified in 14.5. The MAUs associated with the repeater set that are connected in this manner shall be subject to the restrictions of MAUs, as specified in 9.4.1.

9.5 Basic Functions

9.5.1 Repeater Set Network Properties. The repeater set shall be transparent to all network acquisition activity and to all DTEs. The repeater set shall not alter the basic fairness criterion for all DTEs to

access the network or weigh it toward any DTE or group of DTEs regardless of network location. A repeater set shall not attempt to be a packet store and forward device.

Repeaters are not addressable. An addressable station on the network that controls a repeater is outside the scope of this standard.

9.5.2 Signal Amplification. The repeater set (including its associated or integral MAUs) shall ensure that the amplitude characteristics of the signals at the MDI outputs of the repeater set are within the tolerance of the specification for the appropriate MAU type. Therefore, any loss of signal-to-noise ratio due to cable loss and noise pickup is regained at the output of the repeater set as long as the incoming data is within the system specification.

9.5.3 Signal Symmetry. The repeater set shall ensure that the symmetry characteristics of the signals at the MDI outputs of a repeater set are within the tolerance of the specification for the appropriate MAU type. Therefore, any loss of symmetry due to MAUs and media distortion is regained at the output of the repeater set.

9.5.4 Signal Retiming. The repeater unit shall ensure that the encoded data output from the repeater unit is within the jitter tolerance of a transmitting DTE as specified in 7.3. Therefore jitter cannot accumulate over multiple segments.

9.5.5 Data Handling. The repeater unit, when presented a packet at any of its ports, shall pass the data frame of said packet intact and without modification, subtraction, or addition to all other ports connected with the repeater unit. The only exceptions to this rule are when contention exists among any of the ports or when the receive port is partitioned as defined in 9.6.6. Between unpartitioned ports, the rules for collision handling (9.5.6) take precedence.

9.5.5.1 Start of Packet Propagation Delays. The start of packet propagation delay for a repeater set is the time delay between the first edge transition of the packet on its repeated from (input) port to the first edge transition of the packet on its repeated to (output) port (or ports).

For a repeater unit with AUI connectors at input and output ports, this time shall be less than or equal to 8 bit times.

For a repeater set with internal FOMAU's, 10BASE2, or 10BASE5 MAUs on both input and output ports, an additional 6.5 bit times delay for an input port MAU and 3.5 bit times delay for an output port MAU shall be allowed. This added delay does not include any dc rise time for the coaxial cable.

For a repeater set with internal 10BASE-T MAUs on input and output ports, an additional 8 BT delay for an input port MAU and 5 BT delay for an output port MAU shall be allowed.

9.5.6 Collision Handling

9.5.6.1 Collision Presence. The repeater set shall implement the Collision Presence Function using receive-mode collision detection as specified for the media with which it is connected.

9.5.6.2 Jam Generation. If a collision is detected on any of the ports to which the repeater set is transmitting, the repeater set shall transmit a Jam to all of the ports to which it is connected. The Jam shall be transmitted in accordance with the Repeater Unit State Diagram in Fig 9-2 and shall be as specified in 4.2.3.2.4 with the further constraint that the first 62 bits transmitted to any port shall be a pattern of alternate 1's and 0's starting with the first bit transmitted as a 1.

9.5.6.3 Collision-Jam Propagation Delays. The start of collision propagation delay for a repeater set is the time delay between the first edge transition of the *signal_quality_error* signal on any of its ports to the first edge transition of the Jam on its (output) port (or ports).

For a repeater unit with AUI connectors at input and output ports, this time shall be less than or equal to 6.5 bit times.

For a repeater set with internal FOMAU's, 10BASE2, or 10BASE5 MAUs on both input and output ports, an additional allowance of 9 bit times delay for an input port MAU and 3.5 bit times delay for an output port MAU shall be made. This added delay does not include any dc rise time for the coaxial cable.

For a repeater set with internal 10BASE-T MAUs on input and output ports, an additional 9 BT delay for an input port MAU and 5 BT delay for an output port MAU shall be allowed.

The cessation of Jam propagation delay for a repeater unit is the time delay between the input signals at its ports reaching a state such that Jam should end at a port and the last transition of Jam at that port. The states of the input signals that should cause Jam to end are covered in detail in the repeater state diagrams.

For a repeater unit with AUI connectors at input and output ports, this time shall be less than or equal to 5 bit times when not extending fragments. When extending fragments, this delay may be longer as required by the fragment extension algorithm. See 9.5.4.

For a repeater set with internal FOMAU, 10BASE2, and 10BASE5 MAUs on its input ports, an additional allowance of 0.5 bit time delay for DI and 20 bit times for *signal_quality_error* deassertion shall be made. For a repeater set with internal FOMAU, 10BASE2, and 10BASE5 MAUs on its output ports, an additional allowance of 0.5 bit time delay shall be made. This added delay does not include any dc fall time for the coaxial cable.

For a repeater set with internal 10BASE-T MAUs on its input ports, an additional 2 BT delay for DI and 9 BT for *signal_quality_error* deassertion shall be allowed. For a repeater set with internal MAUs on its output ports, an additional 2 BT delay shall be allowed.

9.5.6.4 Transmit Recovery Time. It is essential that the repeater unit not monitor a port for input for a short time after the repeater stops transmitting to that port. This recovery time prevents the repeater from receiving its own transmission as a new receive activity. The minimum recovery time allowable for a repeater is implementation-dependent, but must be greater than the sum of the delays in the transmit and receive paths for the port. In all cases the recovery time must be less than 10 bit times from the last transition on the transmitting AU Interface.

9.5.6.5 Carrier Recovery Time. During a collision, the *input_idle* signal is unreliable for short periods of time (bits) because of the possibility of signal cancellation on the collision segment. In order to prevent premature detection of the true end of the collision, the repeater unit must wait for data to become sensed from a port for a short time after *signal_quality_error* has gone inactive from that port. This recovery time prevents the repeater from prematurely ending a Jam on an active network. The minimum carrier recovery time allowable for a repeater is implementation-dependent, but shall be greater than the CARRIER ON time after *signal_quality_error* is deasserted. In all cases, the carrier recovery time shall be less than 4 bit times from the last transition on the AU Interface.

9.5.7 Electrical Isolation. Network segments that have different isolation and grounding requirements shall have those requirements provided by the port-to-port isolation of the repeater set.

9.6 Detailed Repeater Functions and State Diagrams. A precise algorithmic definition is given in this section, providing a complete procedural model for the operation of a repeater, in the form of state diagrams. Note that whenever there is any apparent ambiguity concerning the definition of repeater operation, the state diagrams should be consulted for the definitive statement.

The model presented in this section is intended as a primary specification of the functions to be provided by any repeater unit. It is important to distinguish, however, between the model and a real implementation. The model is optimized for simplicity and clarity of presentation, while any realistic implementation should place heavier emphasis on such constraints as efficiency and suitability to a particular implementation technology.

It is the functional behavior of any repeater unit implementation that shall match the standard, not the internal structure. The internal details of the procedural model are useful only to the extent that they help specify the external behavior clearly and precisely. For example, the model uses a separate Transmit Timer state machine for each port. However, in an actual implementation, the hardware may be shared.

9.6.1 State Diagram Notation. The notation used in the state diagrams (Figs 9-2 through 9-5) follows the conventions in 1.2.1.

Description of State Diagram Variables

Input/Output Variables

DataIn (X)

Status of DataIn input at port X.

Values: II = *input_idle*; indicates no activity

-II; indicates activity

Note that DataIn (X) may be undefined during collision

but that it is a don't care in all instances when this is true.

CollIn (X)

Status of Controlln input at port X.

Values: SQE = *signal_quality_error*; indicates collision

-SQE; indicates no collision

Out (X)

Type of output repeater is sourcing at port X.

Values: Idle; Repeater is not transmitting

-Idle; Repeater is transmitting Preamble Pattern
or Data or Jam or TwoOnes.

Preamble Pattern; Repeater is sourcing alternating 1's and
0's on port X.

Data; Repeater is repeating data frame on port X.

Jam; Repeater is sourcing Jam on port X.

TwoOnes; Repeater is sourcing two consecutive Manchester
encoded ones on port X.

DisableOut (X)

Override of Out (X)

Values: ON; Disable repeater transmission regardless of value of Out (X).

-ON; Repeater transmission depends on the value of Out (X).

Port Variables

TT (X)

Transmit Timer indicates number of bits transmitted on port X.

Values: Positive integers

Inter-Process Flags

AllDataSent

All received data frame bits have been sent.

Bit Transmitted

Indicates a bit has been transmitted by the repeater unit.

DataRdy

Indicates the repeater has detected the SFD and is ready to send the received data. The search for SFD shall not begin before 15 bits have been received. Note, transmit and receive clock differences shall also be accommodated.

Tw1

Wait Timer for the end of transmit recovery time (see 9.5.5.4). It is started by StartTw1. Tw1Done is satisfied when the end of transmit recovery time is completed.

Tw2

Wait Timer for the end of carrier recovery time (see 9.5.6.5). It is started by StartTw2. Tw2Done is satisfied when the timer has expired.

Tw3

Wait Timer for length of continuous output (see 9.6.5). It is started by StartTw3. Tw3Done is satisfied when the timer has expired.

Tw4

Wait Timer for time to disable output for Jabber Lockup Protection (see 9.6.5). It is started by StartTw4. Tw4Done is satisfied when the timer has expired.

Port Functions**Port (Test)**

A function that returns the designation of a port passing the test condition. For example, Port (CollIn=SQE) returns the designation: X for a port that has SQE true. If multiple ports meet the test condition, the Port function will be assigned one and only one of the acceptable values.

Port Designation

Ports are referred to by number. Port information is obtained by replacing the X in the desired function with the number of the port of interest. Ports are referred to in general as follows:

ALL	Indicates all repeater ports are to be considered. All ports shall meet test conditions in order for the test to pass.
ANY	Indicates all ports are to be considered. One or more ports shall meet the test conditions in order for the test to pass.
ONLY1	Indicates all ports are to be considered. One, but not more than one, port shall meet the test condition in order for the test to pass.
X	Generic port designator. When X is used in a state diagram, its value is local to that diagram and not global to the set of state diagrams.
N	Is defined by the Port function on exiting the IDLE state of Fig 9-2. It indicates a port that caused the exit from the IDLE state.
M	Is defined by the Port function on exiting the TRANSMIT COLLISION state of Fig 9-2. It indicates the only port where CollIn=SQE.
ALLXN	Indicates all ports except N should be considered. All ports considered shall meet the test conditions in order for the test to pass.
ALLXM	Indicates all ports except M should be considered. All ports considered shall meet the test conditions in order for the test to pass.
ANYXN	Indicates any port other than N meeting the test conditions shall cause the test to pass.
ANYXM	Indicates any port other than M meeting the test conditions shall cause the test to pass.

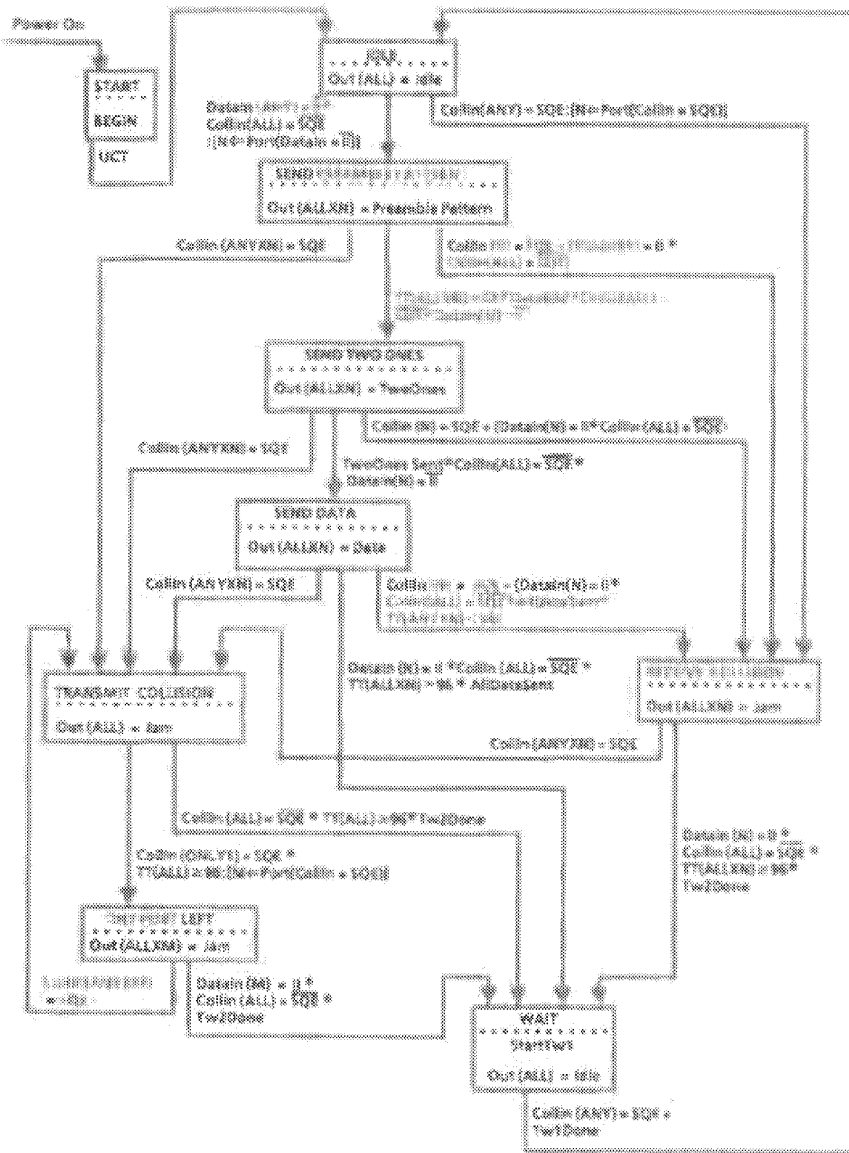

NOTE: Out (X) = Idle in all instances unless specified otherwise.

Fig 9-2
 Repeater Unit State Diagram

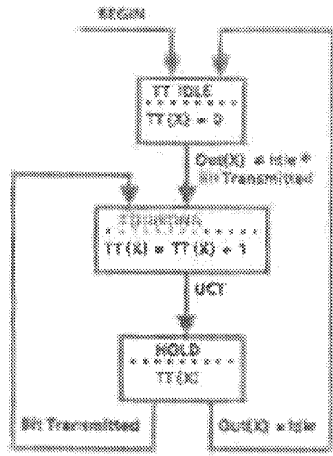

Fig 9-3
Transmit Timer State Diagram
for Port X

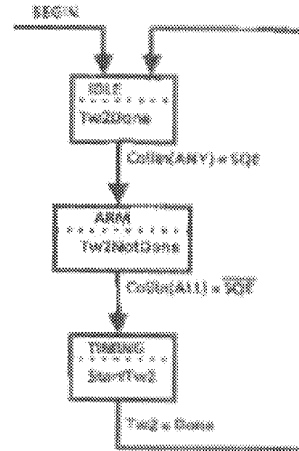

Fig 9-4
Tw2 State Diagram

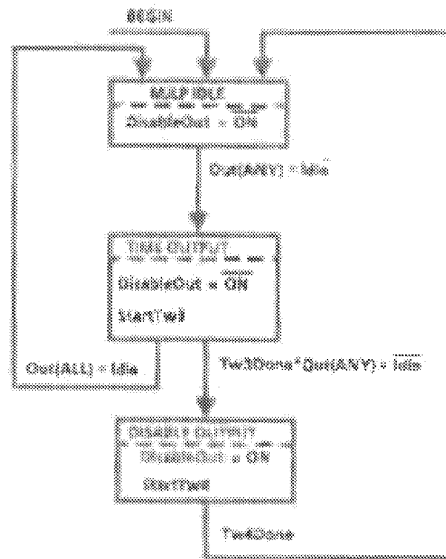

Fig 9-5
MAU Jabber Lockup Protection State Diagram

9.6.2 Data and Collision Handling. The repeater unit shall implement the CARRIER_ON function for all its ports. Upon detection of carrier from one port, the repeater unit shall repeat all received signals in the Data Frame from that port to the other port (or ports).

The repeater unit data and collision-handling algorithm shall be as defined in Fig 9-2.

9.6.3 Preamble Regeneration. The repeater unit shall output at least 56 bits of preamble followed by the SFD. When the repeater unit must send more than 56 bits, the maximum length preamble pattern it shall send is the number received plus 6.

9.6.4 Fragment Extension. If the received bit sequence from CARRIER_ON to CARRIER_OFF is fewer than 96 bits in length, including preamble, the repeater unit shall extend the output bit sequence with Jam such that the total number of bits output from the repeater unit shall equal 96.

9.6.5 MAU Jabber Lockup Protection. MAU Jabber Lockup Protection must operate as shown in the MAU Jabber Lockup Protection state diagram. The repeater unit shall interrupt its output if it has transmitted continuously for longer than 5 ms or 50 000 bit times $- 20\% + 50\%$. The repeater unit shall then, after 96 to 116 bit times (9.6 to 11.6 μ s), re-enable transmissions.

9.6.6 Auto-Partitioning/Reconnection (Optional)

9.6.6.1 Overview. In large multisegment networks it may be desirable that the repeater unit protect the network from some fault conditions that would halt all network communication. A potentially likely cause of this condition could be due to a cable break, a faulty connector, or a faulty or missing termination.

In order to isolate a faulty segment's collision activity from propagating through the network, the repeater unit may optionally implement an auto-partition algorithm and, on detection of the malfunction being cleared, an auto-reconnection algorithm.

9.6.6.2 Detailed Auto-Partition/Reconnection Algorithm State Diagram. Repeater sets with 10BASE-T MAUs shall implement an auto-partition/reconnection algorithm on those parts. The repeater unit may optionally implement an auto-partition/reconnection algorithm that protects the rest of the network from an open-circuited segment. If the repeater unit provides this function, it shall conform to the state diagram of Fig 9-6.

The algorithm defined in Fig 9-6 shall isolate a segment from the network when one of the following two conditions has occurred on the segment:

- (1) When a consecutive collision count has been reached; or
- (2) When a single collision duration has exceeded a specific amount of time.

When a segment is partitioned, DataIn (X) and CollIn (X) from that segment are forced to II (input idle) and -SQE (no collision), respectively, so that activity on the port will not affect the repeater unit. Output from the repeater to the segment is not blocked.

The segment will be reinstated when the repeater has detected activity on the segment for more than the number of bits specified for Tw0 without incurring a collision.

Description of State Diagram Variables and Constants

Port Constants

CCLimit

The number of consecutive collisions that must occur before a segment is partitioned. The value shall be greater than 30.

Input/Output Variables

DIPresent(X)

Data in from the MAU on port X. (This input is gated by the partition state machine to produce DataIn (X) to the main state machine.)

Values: II = *input_idle* ; no activity
-II = input not idle ; activity

CIIPresent(X)

Control input from the MAU on port X. (This input is gated by the partition state machine to produce CollIn (X) to the main state machine.)

Values: SQE = *signal_quality_error* ; indicates collision
-SQE ; indicates no collision

Port Variables

CC(X)

Consecutive port collision count on a particular port X. Partitioning occurs on a terminal count of CCLimit being reached.

Values: Positive integers up to a terminal count of CCLimit.

Inter-Process Flags

Tw5

Wait Timer for length of packet without collision. Its value shall be between 450 and 500 bit times. It is started by StartTw5. Tw5Done is satisfied when the timer has expired.

Tw6

Wait Timer for excessive length of collision. Its value shall be between 1000 and 30 000 bit times. It is started by StartTw6. Tw6Done is satisfied when the timer has expired.

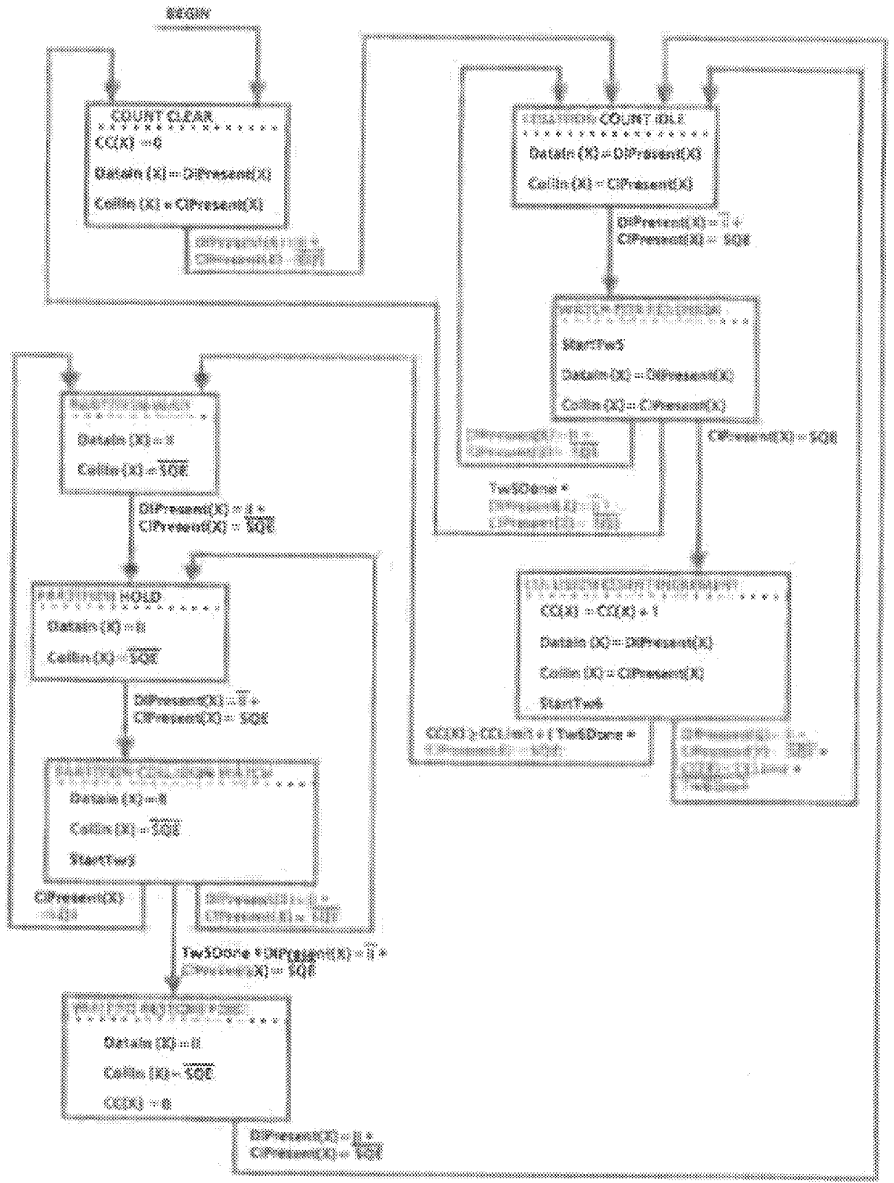

Fig 9-6
Partitioning State Diagram for Port X

9.7 Electrical Isolation. There are two electrical power distribution environments to be considered that require different electrical isolation properties.

- Environment A — When a LAN or LAN segment, with all its associated interconnected equipment, is entirely contained within a single low-voltage power distribution system and within a single building.
- Environment B — When a LAN crosses the boundary between separate power distribution systems or the boundaries of a single building.

The repeater unit shall comply with applicable local and national codes related to safety. See ECMA-97 [A9].

9.7.1 Environment A Requirements. Attachment of network segments via repeaters (sets) possessing internal MAUs requires electrical isolation of 500 Vrms, 1 minute withstand, between the segment and the protective ground of the repeater unit.

For repeater ports that connect to external MAUs via an AU Interface, the requirement for isolation is encompassed within the isolation requirements of the basic MAU standard. (See 8.3.2.1, 10.4.2.1, and 14.3.11.) The repeater unit shall not require any electrical isolation between exposed AU Interfaces or between exposed AU Interfaces and chassis ground of the repeater unit. No isolation boundary need therefore exist at any AUI compatible interface (that is "D" connector) provided by a repeater unit.

9.7.2 Environment B Requirements. The attachment of network segments, which cross environment A boundaries, requires electrical isolation of 1500 Vrms, 1 minute withstand, between each segment and all other attached segments and also the protective ground of the repeater unit.

It is recommended that this isolation be provided by the use of external MAUs connected by AU Interfaces. If internal MAUs are used the segments shall be installed such that it is not possible for an equipment user to touch the trunk cable screen or signal conductor. A repeater of this variety requires professional installation.

The requirements for interconnected coaxial cable/electrically conducting LAN segments that are partially or fully external to a single building environment may require additional protection against lightning strike hazards. Such requirements are beyond the scope of this standard. It is recommended that the above situation be handled by the use of a nonelectrically conducting IRL (for example, fiber optic).

It is assumed that any nonelectrically conducting segments will provide sufficient isolation within that media to satisfy the isolation requirements of environment B.

9.8 Reliability. A 2-port repeater set shall be designed to provide a mean time between failure (MTBF) of at least 50 000 hours of continuous operation without causing a communication failure among stations attached to the network medium. Repeater sets with more than two ports shall add no more than 3.46×10^{-6} failures per hour for each additional port.

The repeater set electronics shall be designed to minimize the probability of component failures within the repeater electronics that prevent communication among the other MAUs on the individual coaxial cable segments. Connectors and other passive components comprising the means of connecting the repeater to the coaxial cable shall be designed to minimize the probability of total network failure.

9.9 Medium Attachment Unit and Baseband Medium Specification for a Vendor-Independent FOIRL

9.9.1 Scope

9.9.1.1 Overview. A vendor-independent FOIRL provides a standard means for connecting only two repeater units. It thus extends the network length and topology beyond that which could be achieved by interconnecting coaxial segments via repeater sets only, as defined in 8.6 or 10.7. A vendor-independent FOIRL is particularly suited for interconnecting coaxial segments located in different buildings. The FOMAU described in this document is not intended for use in connecting DTEs.

In particular, this section defines the following:

- (1) The functional, optical, electrical, and mechanical characteristics of a fiber optic MAU (FOMAU) suitable for interfacing to a repeater unit, either directly (FOMAU and repeater unit integrated into a single package) or via an AUI mechanical connection.
- (2) Various optical fiber sizes suitable for connecting only two FOMAU's.

A schematic of the vendor-independent FOIRL and its relationship to the repeater unit is shown in Fig 9-7. The vendor-independent FOIRL comprises an optical fiber cable link segment, a vendor-independent FOMAU at each end of the link segment and, if present, AUI cables.

The purpose of this specification is to enable interoperability of FOMAU's that originate from different manufacturers, thereby facilitating the development of simple and inexpensive inter-repeater links (IRL's). To satisfy this objective, the FOMAU has the following general characteristics:

- (a) Enables coupling the repeater unit PLS directly, or by way of the AUI mechanical connection, to the explicit baseband optical fiber cable link segment defined in this section of the standard.
- (b) Supports signaling at a data rate of 10 Mb/s.
- (c) Provides for driving up to 1000 m of an optical fiber cable link segment.
- (d) Operates indistinguishably from a repeater set MAU, as defined in Section 8, 10, or 14 when viewed from the AU Interface.
- (e) Supports 10BASE2, 10BASE5, and 10BASE-T system configurations as defined in Sections 8, 10, and 13 of this standard.
- (f) Allows integration of the FOMAU into a single package with the repeater unit, thereby eliminating the need for an AUI mechanical connection.

The implementation may incorporate additional features, for example those that allow compatibility with vendor-dependent FOMAU's, as in 9.4.3.1. The means to support these features are beyond the scope of this subsection.

9.9.1.2 Application Perspective: FOMAU and Medium Objectives. This section states the broad objectives underlying the vendor-independent FOIRL specification defined throughout this section of the standard. These are as follows:

- (1) Provide the physical means for connecting only two repeater units.
- (2) Define a physical interface for the vendor-independent FOMAU component of the vendor-independent FOIRL that can be implemented independently among different manufacturers of hardware and achieve the intended level of compatibility when interconnected in a common IRL.
- (3) Provide a communication channel capable of high bandwidth and low bit error rate performance. The resultant BER of the FOIRL should be less than one part in 10^{10} .
- (4) Provide a means to prevent packet transmission through an FOIRL when transmission capability in one or both directions is disrupted.

9.9.1.3 Compatibility Considerations. All implementations of the vendor-independent FOMAU shall be compatible at the FOMDI and at the AUI (when physically and mechanically implemented).

This standard provides an optical fiber cable link segment specification for the interconnection of only two FOMAU devices. The medium itself, the functional capability of the FOMAU, and the AUI are defined to provide the highest possible level of compatibility among devices designed by different manufacturers. Designers are free to implement circuitry within the FOMAU in an application-dependent manner provided the FOMDI and AUI are satisfied. (The provision of the physical and mechanical implementation of the AUI is optional.)

9.9.1.4 Relationship to AUI. A close relationship exists between this section and Section 7. This section specifies all of the physical medium parameters, all of the FOMAU logical functions residing in the FOMAU, and references the AUI defined in Section 7 with the exception of the *signal_quality_error* message (test of 7.2.1.2.3(3), which shall not be implemented, that is, shall not be enabled when connected to a repeater unit.

NOTE: The specification of a FOMAU component requires the use of both this section and Section 7 for the AUI specifications.

9.9.1.5 Mode of Operation. The FOMAU functions as a direct connection between the optical fiber cable link segment and the repeater unit. During collision-free operation, data from the repeater unit is

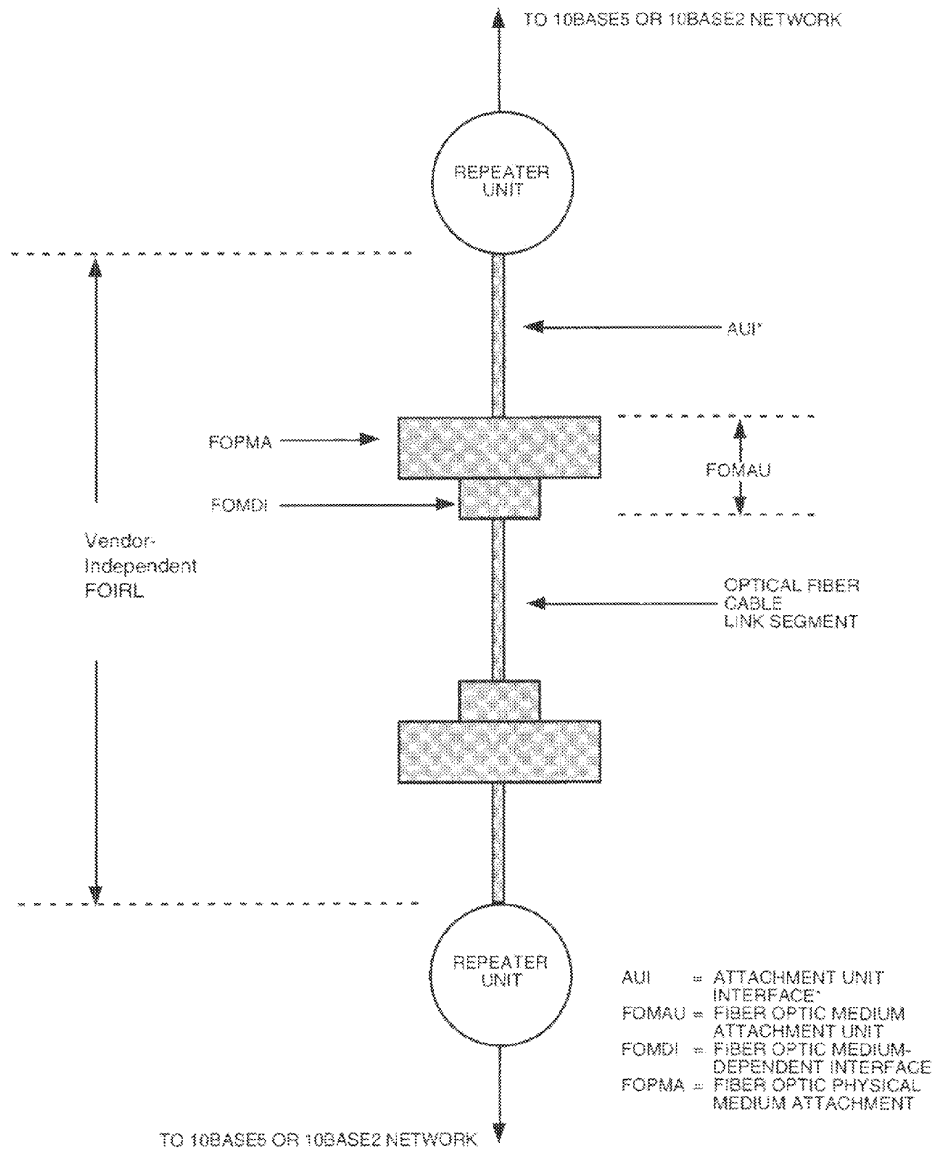

* See 9.9.1.3 for implementation requirements.

Fig 9-7
Schematic of the Vendor-Independent FOIRL and Its Relationship to the Repeater Unit

transmitted into the FOMAU's transmit optical fiber, and all data in the FOMAU's receive optical fiber is transmitted to the repeater unit.

9.9.2 FOMAU Functional Specifications. The FOMAU component provides the means by which signals on the three AUI signal circuits are coupled:

- (1) From the repeater unit into the FOMAU's transmit optical fiber, and
- (2) From the FOMAU's receive optical fiber to the repeater unit.

To achieve this basic objective, the FOMAU component contains the following functional capabilities to handle message flow between the repeater unit and the optical fiber cable link segment:

- (a) *Transmit Function* : The ability to receive serial bit streams from the attached repeater unit and transmit them into the FOMAU's optical fiber.
- (b) *Receive Function* : The ability to receive serial data bit streams from the FOMAU's receive optical fiber and transmit them to the attached repeater unit.
- (c) *Collision Presence Function* : The ability to detect, and report to the attached repeater unit, an FOIRL collision.
- (d) *Jabber Function* : The ability to automatically interrupt the Transmit Function and inhibit an abnormally long output data stream.
- (e) *Low Light Level Detection Function* : The ability to automatically interrupt the Receive Function and inhibit the reception of signals from the FOMAU's receive optical fiber which could result in abnormally high BERs.

9.9.2.1 Transmit Function Requirements. At the start of a packet transmission into the FOMAU's transmit optical fiber, no more than two bits (two full bit cells) of information may be received from the DO circuit and not transmitted into the FOMAU's transmit optical fiber. In addition, it is permissible for the first bit sent to contain encoded phase violations or invalid data. All successive bits of the packet shall be transmitted into the FOMAU's transmit optical fiber and shall exhibit the following:

- (1) No more edge jitter than that given by the sum of the worst-case edge jitter components specified in 7.4.3.6, 7.5.2.1, and 9.9.4.1.7, and
- (2) The levels and waveforms specified in 9.9.4.1.

The FOMAU DO circuit shall comply with the AUI specification for receivers given in 7.4.2. The FOMAU's DI circuit driver shall comply with the AUI specification for drivers given in 7.4.1.

The steady-state propagation delay between the DO circuit receiver input and the FOMAU's transmit optical fiber input shall not exceed one-half a bit cell. It is recommended that the designer provide an implementation in which a minimum threshold level is required on the DO circuit to establish a transmit bit stream.

The higher optical power level transmitted into the FOMAU's transmit optical fiber shall be defined as the low (LO) logic state on the optical fiber link segment. There shall be no logical signal inversions between the DO circuit and the FOMAU's transmit optical fiber, as specified in 9.9.4.1.5.

The difference in the start-up delay (bit loss plus invalid bits plus steady-state propagation delay), as distinct from the absolute start-up delays, between any two packets that are separated by 9.6 μ s or less shall not exceed 2 bit cells.

The FOMAU shall loop back a packet received from the DO circuit into the DI circuit. At the start of a packet transmission, no more than five bits of information may be received from the DO circuit and not transmitted into the DI circuit. It is permissible for the first bit sent to contain encoded phase violations or invalid data. All successive bits of the packet shall be transmitted into the DI circuit and shall exhibit no more edge jitter than that specified for signals transmitted into the DI circuit by the Receive Function, as specified in 9.9.2.2. The steady-state propagation delay between the DO circuit receiver input and the DI circuit driver output for such signals shall not exceed one bit cell. There shall be no logical signal inversions between the DO circuit and the DI circuit during collision-free transmission.

When the DO circuit has gone idle after a packet has been transmitted into the FOMAU's transmit optical fiber, the FOMAU shall not activate the Collision Presence Function so as not to send the *signal_quality_error* message Test of 7.2.1.2.3(3) to the repeater unit.

During the idle state of the DO circuit, the Transmit Function shall output into the transmit optical fiber an optical idle signal as specified in 9.9.4.1.4. The transmitted optical signals shall exhibit the optical power levels specified in 9.9.4.1.8. At the end of a packet transmission, the first optical idle signal pulse

transition to the higher optical power level must occur no sooner than 400 ns and no later than 2100 ns after the packet's last transition to the lower optical power level. This first optical pulse must meet the timing requirements of 9.9.4.1.4.

The FOMAU shall not introduce extraneous optical signals into the transmit optical fiber under normal operating conditions, including powering-up or powering-down of the FOMAU.

9.9.2.2 Receive Function Requirements. At the start of a packet reception from the FOMAU's receive optical fiber, no more than two bits (two full bit cells) of information may be received from the FOMAU's receive optical fiber and not transmitted into the DI circuit. It is permissible for the first bit transmitted into the DI circuit to contain encoded phase violations or invalid data. All successive bits of the packet shall be transmitted into the DI circuit and shall exhibit the following:

- (1) The levels and waveforms specified in 7.4.1, and
- (2) No more edge jitter than that given by the sum of the worst-case edge jitter components specified in 7.4.3.6, 7.5.2.1, 9.9.4.1.7, 9.9.4.2.2, and 9.9.5.1.

The steady-state propagation delay between the output of the FOMAU's receive optical fiber and the output of the DI circuit driver shall not exceed one-half a bit cell. There shall be no logical signal inversions between the FOMAU's receive optical fiber and the DI circuit during collision-free operation, as specified in 9.9.4.2.3.

The difference in the start-up delay (bit loss plus invalid bits plus steady-state propagation delay), as distinct from the absolute start-up delays, between any two packets that are separated by 9.6 μ s or less shall not exceed 2 bit cells.

The FOMAU shall not introduce extraneous signals into the DI circuit under normal operating conditions, including powering-up or powering-down of the FOMAU.

9.9.2.3 Collision Presence Function Requirements. The signal presented to the CI circuit in the absence of an SQE signal shall be the IDL signal.

The signal presented to the CI circuit during the presence of a collision shall be the CS0 signal, a periodic pulse waveform of frequency 10 MHz $\pm 25\%$ -15% with pulse transitions that are no less than 35 ns and no greater than 70 ns apart at the zero crossing points. This signal shall be presented to the CI circuit no more than 3.5 bit times after the simultaneous appearance of signals at both the input of the FOMAU's transmit optical fiber and the output of the FOMAU's receive optical fiber. This signal shall be deasserted no earlier than 4.5 bit times and no later than 7 bit times after the above defined collision condition ceases to exist.

During a collision, if a packet is received at the DO circuit before a packet is received at the FOMAU's receive optical fiber, then only the packet received at the DO circuit shall be transmitted into the DI circuit, as specified in 9.9.2.1. Conversely, if during a collision a packet is received at the FOMAU's receive optical fiber before a packet is received at the DO circuit, then only the packet received at the FOMAU's receive optical fiber shall be transmitted into the DI circuit, as specified in 9.9.2.2. In the event of both packets being received at their respective ports within 3.5 bit times of each other, then either one, but only one, of the packets shall be selected to be transmitted into the DI circuit.

The Collision Function shall not introduce extraneous signals into the CI circuit under normal operating conditions, including powering-up or powering-down of the FOMAU.

9.9.2.4 Jabber Function Requirements. The FOMAU shall have the capability, as defined in Fig 9-9, to interrupt a transmission from the repeater unit that exceeds a time duration determined by the FOMAU. This time duration shall not be less than 20 ms nor more than 160 ms. If the packet being transmitted is still being transmitted after the specified time duration, the FOMAU shall activate the Jabber Function by the following:

- (1) First inhibiting the transmission of bits from its DO circuit into its transmit optical fiber,
- (2) Then transmitting into its transmit optical fiber the optical idle signal specified in 9.9.4.1.4, and
- (3) Presenting the CS0 signal to the CI circuit.

Once the error condition has been cleared, the FOMAU shall reset the Jabber Function and present the IDL signal to the CI circuit:

- (a) On power reset, and
- (b) Optionally, automatically after a continuous period of 0.5 s \pm 50% of inactivity on the DO circuit.

The FOMAU shall not activate its Jabber Function when operated under the worst-case Jabber Lockup Protection condition specified in 9.6.5.

When both the Jabber Function and the Low Light Level Detection Function (see 9.9.2.5) have been activated, the Jabber Function shall override the Low Light Level Detection Function.

9.9.2.5 Low Light Level Detection Function Requirements. The FOMAU shall have a low light level detection capability, as defined in Fig 9-10, whereby it shall interrupt the reception of both the optical idle signal and packets from the FOMAU's receive optical fiber when reliable reception can no longer be assured. This error condition shall not be activated if the peak optical power level at the output of the FOMAU's receive optical fiber exceeds -27 dBm. It shall be activated before the peak optical power level at the output of the FOMAU's receive optical fiber has fallen to a level that is lower than the peak optical power level that corresponds to a BER = 10^{-10} for the FOMAU under consideration. Once this error condition has been activated, the FOMAU shall, no earlier than 30 bit times and no later than 200 bit times

- (1) Disable its Receive Function so that the transmission of bits from its receive optical fiber to the DI circuit is inhibited.
- (2) Assure that only the optical idle signal is transmitted into its transmit optical fiber, irrespective of the state of the DO circuit.
- (3) Disable its Transmit Function during the period of time that the FOMAU recognizes the presence of a packet on the DO circuit such that the transmission of the packet from the DO circuit into the DI circuit is inhibited.

Once this error condition has been cleared, the FOMAU shall return automatically to its normal mode of operation within 40 bit times once the DO circuit is in the idle state.

When both the Jabber Function (see 9.9.2.4) and the Low Light Level Detection Function have been activated, the Jabber Function shall override the Low Light Level Detection Function.

NOTE: It is recommended that, for diagnostic purposes, the status of the Low Light Level Detection Function be indicated on the exterior of the FOMAU package.

9.9.2.6 Repeater Unit to FOMAU Physical Layer Messages. The following messages can be received by the FOMAU physical layer entities from the repeater unit:

Message	Circuit	Signal	Meaning
<i>output</i>	DO	CDI, CD0	Output information
<i>output_idle</i>	DO	IDL	No data to be output

9.9.2.7 FOMAU Physical Layer to Repeater Unit Messages. The following messages can be sent by the FOMAU physical layer entities to the repeater unit:

Message	Circuit	Signal	Meaning
<i>input</i>	DI	CDI, CD0	Input information
<i>input_idle</i>	DI	IDL	No information to be input
<i>fomau_available</i>	CI	IDL	FOMAU is available for output
<i>signal_quality_error</i>	CI	CS0	Collision or error detected by FOMAU

9.9.2.7.1 *input* Message. The FOMAU physical layer sends an *input* message to the repeater unit when the FOMAU has a bit of data to send to the repeater unit. The physical realization of the *input* message is a CD0 or CD1 sent by the FOMAU to the repeater unit on the DI circuit. The FOMAU sends CD0 if

the input bit is a zero, or CD1 if the input bit is a one. No retiming of the CD1 or CD0 signals takes place within the FOMAU.

9.9.2.7.2 *input_idle* Message. The FOMAU physical layer sends an *input_idle* message to the repeater unit when the FOMAU does not have data to send to the repeater unit. The physical realization of the *input_idle* message is the IDL signal sent by the FOMAU to the repeater unit on the DI circuit.

9.9.2.7.3 *fomau_available* Message. The FOMAU physical layer sends the *fomau_available* message to the repeater unit when the FOMAU is available for output, and when the FOMAU has activated the Low Light Level Detection Function in accordance with the Low Light Level Detection Function requirements of 9.9.2.5 and Fig 9-10. The *fomau_available* message shall be sent by a FOMAU that is prepared to output data. The physical realization of the *fomau_available* message is an IDL signal sent by the FOMAU to the repeater unit on the CI circuit.

9.9.2.7.4 *signal_quality_error* Message. The *signal_quality_error* message shall be implemented in the following fashion:

- (1) When the FOMAU has completed the transmission of a packet into its transmit optical fiber, it shall not send any *signal_quality_error* message Test sequence.
- (2) The simultaneous appearance of packets at both the input of a FOMAU's transmit optical fiber and the output of its receive optical fiber shall cause the *signal_quality_error* message to be sent by the FOMAU to the repeater unit.
- (3) When the FOMAU has activated the Jabber Function, it shall send the *signal_quality_error* message in accordance with the Jabber Function requirements of 9.9.2.4 and Fig 9-9.

The physical realization of the *signal_quality_error* message is the CS0 signal sent by the FOMAU to the repeater unit on the CI circuit.

The FOMAU is required to assert the *signal_quality_error* message at the appropriate times whenever the FOMAU is powered and not just when the repeater unit is providing output data.

9.9.2.8 FOMAU State Diagrams. The state diagrams, Figs 9-8, 9-9, and 9-10, depict the full set of allowed FOMAU state functions relative to the control circuits of the repeater unit/FOMAU interface for FOMAU's. Messages used in these state diagrams are explained as follows:

NOTE: Figures 9-8, 9-9, and 9-10 must all be considered together.

- (1) *enable_opt_driver* : Activates the path employed during normal operation to cause the FOMAU transmitter to impress the packet data received from the DO circuit into the FOMAU's transmit optical fiber.
- (2) *disable_opt_driver* : Deactivates the path employed during normal operation to cause the FOMAU transmitter to impress the packet data received from the DO circuit into the FOMAU's transmit optical fiber.
- (3) *enable_opt_idle_driver* : Causes the FOMAU transmitter to impress the optical idle signal into the FOMAU's transmit optical fiber.
- (4) *disable_opt_idle_driver* : Causes the FOMAU to stop transmitting the optical idle signal into the FOMAU's transmit optical fiber.
- (5) *enable_loop_back* : Activates the path employed during normal operation to cause the FOMAU Transmit Function to impress the packet data received from the DO circuit into the DI circuit.
- (6) *disable_loop_back* : Deactivates the path employed during normal operation to cause the FOMAU Transmit Function to impress the packet data received from the DO circuit into the DI circuit.
- (7) *enable_opt_receiver* : Activates the path employed during normal operation to cause the FOMAU to impress the packet data received from the FOMAU's receive optical fiber into the DI circuit.

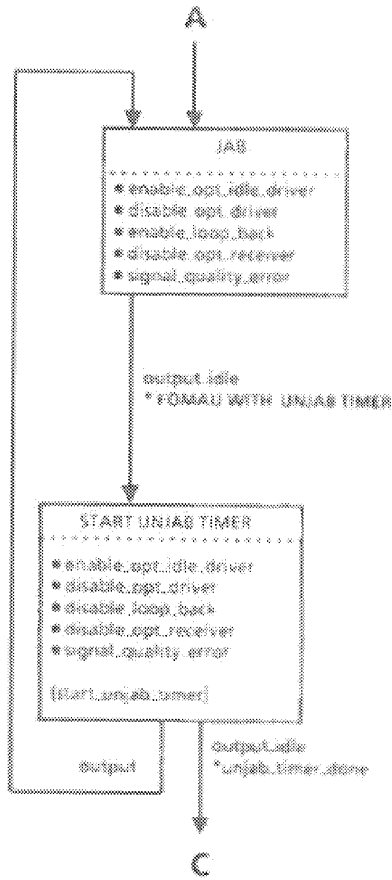

Fig 9-9
FOMAU Jabber Function
State Diagram

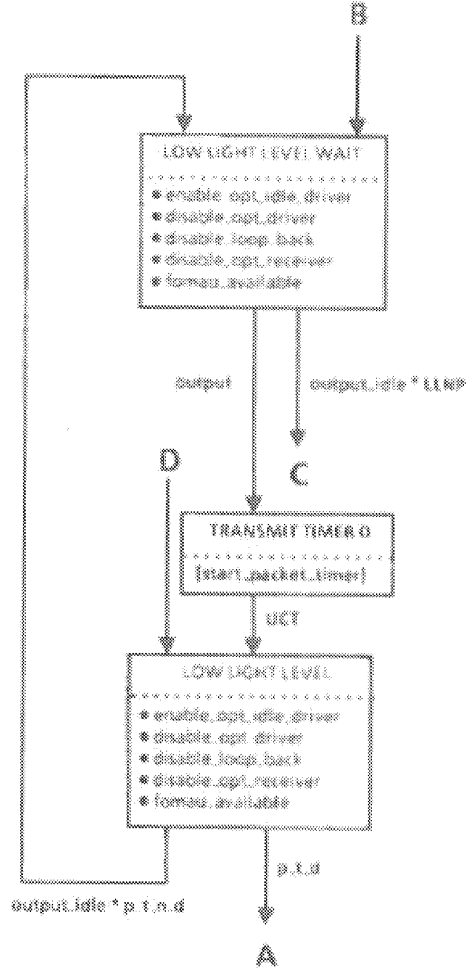

Fig 9-10
Low Light Level Detection
Function State Diagram

- (8) *disable_opt_receiver* : Deactivates the path employed during normal operation to cause the FOMAU to impress the packet data received from the FOMAU's receive optical fiber into the DI circuit.
- (9) *[start_packet_timer]* : Starts a timing function which is used to monitor the amount of time the FOMAU is transmitting a packet into the transmit optical fiber. The timing function is maintained as long as *output* is true and is stopped on the transition to *output_idle true*. The term *packet_timer_done* is satisfied when the timing function has run to expiration (see 9.9.2.4).
- (10) *[start_uqjab_timer]* : Starts a timing function that is used to monitor the amount of time that the Jabber error condition has been clear. The timing function is maintained as long as *output_idle* is true and is stopped on the transition to *output true*. The term *uqjab_timer_done* is satisfied when the timing function has run to expiration (see 9.9.2.4).
- (11) *opt_input* : Signifies that a packet is present at the FOMAU's receive optical fiber.
- (12) *opt_input_idle* : Signifies that a packet is no longer present at the FOMAU's receive optical fiber.
- (13) *opt_input_coll_select* : Signifies that, during a collision, a packet has been received at the DO circuit within 3.5 bit times of a packet being received at the FOMAU's receive optical fiber, and that only the packet received at the FOMAU's receive optical fiber is to be transmitted into the DI circuit.
- (14) *output_coll_select* : Signifies that, during a collision, a packet has been received at the DO circuit within 3.5 bit times of the packet being received at the FOMAU's receive optical fiber, and that only the packet received at the DO circuit is to be transmitted into the DI circuit.

The following abbreviations have been used in Figs 9-6, 9-9, and 9-10:

- (1) LLP = Low Light Level Condition Present
- (2) LLNP = Low Light Level Condition Not Present
- (3) *p_t_d* = *packet_timer_done*
- (4) *p_t_n_d* = *packet_timer_not_done*
- (5) * = logical AND operator

9.9.3 FOMAU Electrical Characteristics

9.9.3.1 Electrical Isolation. Electrical isolation shall be provided between FOMAUs attached to the FOIRL by the optical fiber cable link segment. There shall be no conducting path between the optical medium connector plug and any conducting element within the optical fiber cable link segment. This isolation shall withstand at least one of the following electrical strength tests:

- (1) 1500 V rms at 50–60 Hz for 60 s, applied as specified in 5.3.2 of IEC Publication 950 [8].
- (2) 2250 V dc for 60 s, applied as specified in 5.3.2 of IEC Publication 950 [8].
- (3) A sequence of ten 2400 V impulses of alternating polarity, applied at intervals of not less than 1 s. The shape of the impulses shall be 1.2/50 μ s (1.2 μ s virtual front time, 50 μ s virtual time of half value), as defined IEC Publication 60 [11].

There shall be no isolation breakdown, as defined in 5.3.2 of IEC Publication 950 [8], during the test. The resistance after the test shall be at least 2 M Ω , measured at 500 V dc.

NOTE: Although isolation is provided by the optical fiber cable link segment, it is recommended that the normal noise immunity provided by common-mode isolation on the AUI be retained.

9.9.3.2 Power Consumption. The current drawn by the FOMAU shall not exceed 0.5 A when powered by the AUI source. The FOMAU shall be capable of operating from all possible voltage sources as supplied by the repeater unit (7.5.2.5 and 7.5.2.6) through the resistance of all permissible AUI cables. The surge current drawn by the FOMAU on power-up shall not exceed 5 A peak for a period of 10 ms. In addition, the FOMAU shall be capable of powering-up from 0.5 A current limited sources.

It is permissible as an option to provide a separate power source for the FOMAU. If a separate power source is implemented, provision will be made to assure that power shall under no circumstances be sourced on pin 13 (Circuit VP) of the AUI.

The FOMAU shall be labeled externally to identify the maximum value of power supply current required by the device when the AUI mechanical connection is implemented.

The FOMAU shall not introduce into the FOMAU's transmit optical fiber or onto the DI or CI circuits of the AUI any extraneous signal on routine power-up or power-down under normal operating conditions.

The FOMAU shall be fully functional no later than 0.5 s after power is applied to it.

9.9.3.3 Reliability. The FOMAU shall be designed to provide a MTBF of at least 200 000 hours of operation without causing a communication failure amongst DTEs attached to the network. The FOMAU electronics shall be designed to minimize the probability of component failures within the FOMAU that prevent communication amongst other MAUs on the 10BASE5 and 10BASE2 segments. Connectors and other passive means of connection shall be designed to minimize the probability of total network failure.

9.9.3.4 FOMAU/Repeater Unit Electrical Characteristics. The electrical characteristics of the driver and receiver components connected to the AUI cable shall be identical to those specified in Section 7.

9.9.3.5 FOMAU/Repeater Unit Mechanical Connection. The FOMAU, if it implements the AUI mechanical connection, shall be provided with a 15-pin male connector, as specified in the AUI specification of Section 7.

9.9.4 FOMAU/Optical Medium Interface

9.9.4.1 Transmit Optical Parameters

9.9.4.1.1 Wavelength. The center wavelength of the optical source emission shall be between 790 and 860 nm. See Appendix D.

9.9.4.1.2 Spectral Width. The spectral width of the optical source shall be less than 75 nm full width half maximum (FWHM).

9.9.4.1.3 Optical Modulation. The optical modulation during packet transmission shall be on-off keying of the optical source power. The minimum extinction ratio shall be 13 dB.

9.9.4.1.4 Optical Idle Signal. During the idle state of the DO circuit, the Transmit Function shall input into the FOMAU's transmit optical fiber an optical idle signal. This signal shall consist of a periodic pulse waveform of frequency 1 MHz $\pm 25\%$ -15% with a duty cycle ratio between 45/55 and 55/45.

9.9.4.1.5 Transmit Optical Logic Polarity. The higher optical power level transmitted into the FOMAU's transmit optical fiber shall correspond to the low (LO) logic state (see 7.4.2.1) of the AUI DO circuit.

9.9.4.1.6 Optical Rise and Fall Times. The optical rise and fall times of the FOMAU shall be no more than 10 ns from the 10% to the 90% levels. There shall be no more than 3 ns difference between the rise and fall times.

9.9.4.1.7 Transmit Optical Pulse Edge Jitter. The additional edge jitter introduced by the FOMAU from the input of the DO circuit receiver to the output of the electro-optic source shall be no more than 2 ns. The jitter measured at the input of the DO circuit receiver shall be measured at the zero crossing points, as determined from the previous 16 or more transitions in any valid bit stream. The jitter measured at the output of the electro-optic source shall be measured at the power level median of the optical waveform's upper and lower power levels, as determined from the previous 16 or more transitions in any valid optical bit stream.

9.9.4.1.8 Peak Coupled Optical Power. At the beginning of the FOMAU's lifetime, the peak optical power coupled into the FOMAU's transmit optical fiber, when terminated with an optical connector as specified in 9.9.5.2, shall be $-12 \text{ dBm} \pm 2 \text{ dB}$, when measured with a graded index optical fiber of nominal dimension of 62.5 μm core diameter and 0.275 nominal numerical aperture. The actual optical power, which will be coupled into other fiber sizes listed in 9.9.5.1, may differ from the above value. The peak optical power shall be measured in the steady state, and the measurement shall be independent of optical pulse ringing effects. Peak optical overshoot shall not exceed 10%.

NOTE: The above value does not include an aging margin. The source is allocated an aging margin of 3 dB over its operating lifetime. The variation in the peak-coupled optical power due to tolerances allowed by IEC Publication 793-2 [14]¹⁾ for type A1b (62.5/125 μm) fiber is $\pm 1 \text{ dB}$. Hence, the minimum power level at the start of life will be -15 dBm .

9.9.4.2 Receive Optical Parameters

9.9.4.2.1 Receive Peak Optical Power Range. The BER shall be $< 10^{-10}$ for peak optical powers at the output of the FOMAU's receive optical fiber between -27 dBm and -9 dBm .

9.9.4.2.2 Receive Optical Pulse Edge Jitter. The additional edge jitter introduced by the FOMAU from the input of the opto-electric detector to the output of the DI circuit driver shall be no more than 4 ns. The jitter measured at the input of the opto-electric receiver shall be measured at the power level median of the optical waveform's upper and lower power levels as determined from the previous 16 or more transitions in any valid optical bit stream. The jitter measured at the output of the DI circuit driver shall be measured at the zero crossing points as determined from the previous 16 or more transitions in any valid bit stream. This requirement shall apply when the optical receive peak power level is in the range -27 to -9 dBm .

9.9.4.2.3 Receive Optical Logic Polarity. The low (LO) logic state (see 7.4.2.1) on the DI circuit shall correspond to the presence of the higher optical power level at the output of the FOMAU's receive optical fiber.

9.9.5 Characteristics of the Optical Fiber Cable Link Segment. The optical fiber cable link segment is a length of optical fiber cable (IEC Publications 794-1 [15] and 794-2 [16]) containing two optical fibers, as specified in 9.9.5.1, and comprising one or more optical fiber cable sections and their means of

¹⁾This FOURL specification is to be read with the understanding that the following changes to IEC Publications 793-2 [14] have been requested:

(1) Correction of the numerical aperture tolerance in Table III to ± 0.015 .

(2) Addition of another bandwidth category, of $> 150 \text{ MHz}$ referred to 1 km, for the type A1b fiber in Table III.

interconnection. Each optical fiber is terminated at each end in the optical connector plug specified in 9.9.5.2. The two optical fibers correspond to the FOMAU's transmit and receive optical fibers.

9.9.5.1 Optical Fiber Medium. The FOMAU can operate with a variety of optical fiber sizes, e.g., 50/125 μm , 62.5/125 μm , 85/125 μm , 100/140 μm .

Interoperability of FOMAUs that originate from different manufacturers, using any of these fiber sizes, is assured provided that the received peak optical power is between -27 dBm and -9 dBm and the optical fiber cable link segment bandwidth is greater than or equal to 150 MHz.

In order to satisfy the above attenuation and bandwidth criteria for all allowable FOIRL lengths, and assuming up to 4 dB of connection losses within the optical fiber cable link segment, it is recommended that the cabled optical fiber have an attenuation ≤ 4 dB/km and a bandwidth of ≥ 150 MHz referred to 1 km at a wavelength of 850 nm.

The total incremental optical pulse edge jitter introduced by the optical fiber cable link segment shall be less than 1 ns when driven by an optical transmitter as specified in 9.9.4.1. The pulse delay introduced by the optical fiber cable shall not exceed 50 bit times for a 1 km length.

In the specific case of 62.5/125 μm fiber, to ensure interoperability of FOMAUs that originate from different manufacturers:

- (1) The two cabled optical fibers contained in the optical fiber cable link segment shall satisfy the optical fiber parameters specified in IEC Publication 793-2 [14] type A1b (62.5/125 μm),^{1,2} and
- (2) The optical fiber cable link segment shall have an attenuation less than or equal to 8 dB and a bandwidth greater than or equal to 150 MHz.

9.9.5.2 Optical Medium Connector Plug and Socket. The two optical fibers contained in the optical fiber cable link segment shall be terminated at each end in an optical connector plug as specified in IEC Publications 874-1 [18] and 874-2 [19].

The corresponding mating connector socket shall conform with the specifications given in IEC Publications 874-1 and 874-2. This document specifies the mechanical mating face dimensions to ensure mechanical intermateability without physical damage, of all F-SMA connectors covered by the document. In addition, the optical insertion loss when interconnecting two optical connector plugs shall not exceed 2.5 dB (measured using a socket adaptor conforming to the mechanical specifications given in IEC Publications 874-1 and 874-2 and also using two identical fibers, as specified in 9.9.5.1, assuming uniform mode distribution launch conditions).

9.9.6 System Requirements

9.9.6.1 Optical Transmission System Considerations. 9.9.4.2.1 specifies that the BER shall be $< 10^{-10}$ for peak optical powers at the output of the FOMAU's receive optical fiber between -27 dBm and -9 dBm. The value of -9 dBm corresponds to the maximum allowable peak optical power that can be coupled into the worst-case optical fiber specified in 9.9.5.1 at the beginning of the FOMAU's lifetime (see 9.9.4.1.8), and assumes zero optical loss between the optical source output and the optical detector input.

The value of -27 dBm is calculated by subtracting the FOIRL flux budget from the minimum allowable peak optical power that can be coupled into the FOMAU's transmit optical fiber at the beginning of the FOMAU's lifetime (see 9.9.4.1.8). The flux budget is the maximum loss allowed within the FOIRL to guarantee a BER $< 10^{-10}$ assuming worst-case link components. A portion of the flux budget has been allocated as a design margin to allow for degradation and tolerance effects in the optical source. This is noted in the table below as the optical source lifetime degradation. The remaining flux budget of 9 dB assumes a system margin allowance for the optical fiber cable link segment over its lifetime, and may be allocated to the optical fiber cable link segment loss at the discretion of the network planner/installer. The following summarizes the allocated optical flux budgets for the example graded index optical fiber of worst-case dimensions 62.5 μm - 3 μm (i.e., 59.5 μm) core diameter and 0.275 - 0.015 (i.e., 0.260) numerical aperture:

^{1,2}This FOIRL specification is to be read with the understanding that the following changes to IEC Publication 793-2 [14] have been requested:

- (1) Correction of the numerical aperture tolerance in Table III to ± 0.015 .
- (2) Addition of another bandwidth category, of > 150 MHz to 1 km, for the type A1b fiber in Table III.

Start of life minimum peak coupled optical power (9.9.4.1.8)	: -15 dBm
Optical source lifetime degradation	: 3 dB
Maximum optical fiber cable link segment loss including system margin allowance	: 9 dB
Resultant required receive peak optical power	: -27 dBm

9.9.6.2 Timing Considerations. Table 9-1 summarizes the maximum allowable timing budget contributions to the system timing budget for the FOIRL. The last bit in to last bit out delay shall equal the Steady-State Propagation Delay.

Table 9-1
Maximum Allowable Timing Budget Contributions to the FOIRL System Timing Budget

Symbol	Function	Bit Loss (bit times)	Invalid Bits (bit times)	Steady-State Propagation Delay (bit times)	Start-Up Delay (bit times)
I1	OPTICAL DATA IN ASSERT-INPUT	2.0	1.0	0.5	3.5
I2	OUTPUT-TO-OPTICAL DATA OUT ASSERT	2.0	1.0	0.5	3.5
LOOP BACK	DO CIRCUIT ASSERT -DI CIRCUIT ASSERT	5.0	1.0	1.0	7.0
I3	OPTICAL COLLISION -SQE ASSERT	---	---	---	3.5
I4	COLLISION DEASSERT -SQE DEASSERT	---	---	---	7.0*
A1	AUI Propagation	---	---	2.57	2.57
F1	Optical Fiber Propagation per Kilometer	---	---	50	50

*Minimum Start-up Delay for I4 is 4.5 bit times.

9.9.7 Environmental Specifications

9.9.7.1 Safety Requirements

9.9.7.1.1 Electrical Safety. A major application for the vendor-independent FOIRL is for interconnecting 10BASE5 and/or 10BASE2 coaxial cable segments located within different buildings. The level of isolation provided by the optical fiber cable link segment shall be consistent with this application and provide adequate personnel and equipment safety from earth faults and lightning strike hazards.

9.9.7.1.2 Optical Source Safety. The recommendations of IEC 825 Publication [17], if applicable, shall be adhered to in determining the optical source safety and user warning requirements.

9.9.7.2 Electromagnetic Environment

9.9.7.2.1 Susceptibility Levels. Sources of interference from the environment include electromagnetic fields, electrostatic discharge, and transient voltages between earth connections. Several sources of interference contribute to voltage between the optical fiber cable link segment (either a metallic strength member in the cable, a metallic optical connector plug, or the outermost conducting element of the FOMAU for the case of no metallic strength member) and the earth connection of a DTE.

For information on limits and methods of measurements of radio interference characteristics of information technology equipment, see 1.3 in CISPR Publication 22 [1].

The physical channel hardware shall meet its specifications when operating in both of the following conditions:

- (1) Ambient plane wave field of 2 V/m from 10 kHz through 30 MHz and 5 V/m from 30 MHz through 1 GHz.

NOTE: These are the levels typically found 1 km from radio broadcast stations.

- (2) Interference source voltage of 15.8 V peak sine wave of frequency 10 MHz in series with a 50 Ω source resistance applied between the optical fiber cable link segment (either a metallic strength member in the cable, a metallic optical connector plug, or the outermost conducting element of the FOMAU for the case of no metallic strength member) and the earth connection of a DTE.

NOTE: The optical fiber link segment is capable of withstanding higher levels of electromagnetic interference. The above specifications are the minimum requirements for the environment in which the FOMAU is required to operate.

9.9.7.2.2 Emission Levels. The FOMAU and optical fiber cable link segment shall comply with CISPR Publication 22 [1].

9.9.7.3 Temperature and Humidity. The FOMAU and associated connector/cable systems are expected to operate over a reasonable range of environmental conditions related to temperature, humidity, and physical handling such as shock and vibration. Specific requirements and values for these parameters are beyond the scope of this standard. Manufacturers should indicate in the literature associated with the FOMAU (and on the FOMAU if possible) the operating environment specifications to facilitate selection, installation, and maintenance of these components. It is further recommended that such specifications be stated in standard terms, as specified in IEC Publications 68 [12], IEC 794-1 [13], IEC 794-1 [15], and IEC 874-1 [18].

10. Medium Attachment Unit and Baseband Medium Specifications, Type 10BASE2

10.1 Scope

10.1.1 Overview. This standard defines the functional, electrical, and mechanical characteristics of the Medium Attachment Unit (MAU) and one specific medium for use with local area networks. The relationship of this specification to the entire CSMA/CD Local Area Network Specification is shown in Fig 10-1.

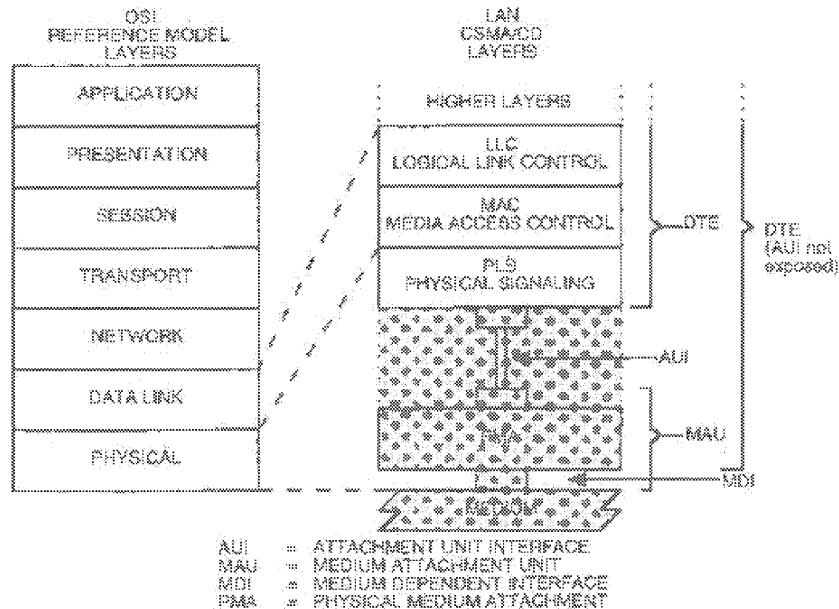

Fig 10-1

Physical Layer Partitioning, Relationship to the ISO Open Systems Interconnection (OSI) Reference Model

The purpose of the MAU is to provide a simple, inexpensive, and flexible means of attaching devices to the local area network medium. This standard defines a means of incorporating the MAU function within the DTE and bringing the trunk coaxial cable directly to the DTE. Interconnection of DTE units is easily achieved by the use of industry standard coaxial cables and BNC connectors.

This MAU and medium specification is aimed primarily at applications where there are a relatively small number of devices located in a work area. Installation and reconfiguration simplicity is achieved by the type of cable and connectors used. An inexpensive implementation is achieved by eliminating the MAU and Attachment Unit Interface (AUI) as separate components and using widely available interconnection components.

10.1.1.1 Medium Attachment Unit (normally contained within the data terminal equipment [DTE]). The MAU has the following general characteristics:

- (1) Enables coupling the PLS to the explicit baseband coaxial transmission system defined in this section of the standard.
- (2) Supports message traffic at a data rate of 10 megabits per second (Mb/s).
- (3) Provides for driving up to 185 m (600 ft) coaxial trunk cable segment without a repeater.
- (4) Permits the DTE to test the MAU and the medium itself.

- (5) Supports system configurations using the CSMA/CD access mechanism defined in the ISO (IEEE) Local Area Network Specification.
- (6) Supports a bus topology interconnection means.
- (7) Supports low-cost capability by incorporating the MAU function within the physical bounds of the DTE, thereby eliminating the need for a separate AU connector and cable but containing the remaining AU interface functionality.

10.1.1.2 Repeater Unit. The Repeater Unit is used to extend the physical system topology and provides for coupling two or more coaxial trunk cable segments. Multiple Repeater Units are permitted within a single system to provide the maximum trunk cable connection path specified in 10.7. The repeater is not a DTE and therefore has slightly different attachment requirements.

10.1.2 Definitions. This section defines the specialized terminology applicable to MAUs and Repeater Units.

Attachment Unit Interface (AUI). In a local area network, the interface between the Medium Attachment Unit (MAU) and the data terminal equipment within a data station.

baseband coaxial system. A system whereby information is directly encoded and impressed on the coaxial transmission medium. At any point on the medium only one information signal at a time can be present without disruption.

carrier sense. In a local area network, an ongoing activity of a data station to detect whether or not another station is transmitting.

NOTE: A collision presence signal is provided by the PLS to the PMA sublayer to indicate that one or more stations are currently transmitting on the trunk coaxial cable.

coaxial cable section. A single length of coaxial cable terminated at each end with a BNC male connector. Cable sections are joined to other cable sections via BNC plug/receptacle barrel or Type T adapters.

coaxial cable segment. A length of coaxial cable made up from one or more coaxial cable sections and coaxial connectors, terminated at each end in its characteristic impedance.

collision. An unwanted condition that results from concurrent transmission on the physical medium.

collision presence. A signal provided by the PLS to the PMA sublayer (within the Data Link Layer) to indicate that multiple stations are contending for access to the transmission medium.

Medium Attachment Unit (MAU). In a local area network, a device used in a data station to couple the data terminal equipment (DTE) to the transmission medium.

Medium Dependent Interface (MDI). The mechanical and electrical interface between the trunk cable medium and the MAU.

Physical Medium Attachment (PMA). The portion of the MAU that contains the functional circuitry.

Physical Signaling Sublayer (PLS). The portion of the Physical Layer, contained within the DTE, that provides the logical and functional coupling between MAU and Data Link Layers.

repeater. A device used to extend the length, topology, or interconnectivity of the physical medium beyond that imposed by a single segment, up to the maximum allowable end-to-end trunk transmission line length. Repeaters perform the basic actions of restoring signal amplitude, waveform, and timing applied to normal data and collision signals.

trunk cable. The trunk coaxial cable system.

NOTE: For additional definitions, see 8.1.2.

10.1.3 Application Perspective: MAU and Medium Objectives. This section states the broad objectives and assumptions underlying the specifications defined throughout Section 10 of the standard.

10.1.3.1 Object

- (1) Provide the physical means for communication between local network Data Link entities.

NOTE: This specification covers a portion of the Physical Layer as defined in the OSI Reference Model and, in addition, the physical medium itself, which is beyond the scope of the OSI Reference Model.

- (2) Define a physical interface that can be implemented independently among different manufacturers of hardware and achieves the intended level of compatibility when interconnected in a common local network.
- (3) Provide a communication channel capable of high bandwidth and low bit error rate performance. The resultant mean bit error rate, at the Physical Layer service interface, should be less than one part in 10^7 (on the order of one part in 10^8 at the link level).
- (4) Provide for ease of installation and service.
- (5) Provide for high network availability (ability of a station to gain access to the medium and enable the Data Link connection in a timely fashion).
- (6) Enable low-cost implementations.

NOTE: The figures and numerous textual references throughout the section refer to terminology associated with the AUI (that is, DO, DI, CI). Since the normal embodiment of the Type 10BASE2 configuration does not require an AUI, actual existence of the DO, DI, CI circuit may not be required. Use of this terminology, however, is retained throughout Section 10 for purposes of clarity and consistency.

10.1.3.2 Compatibility Considerations. All implementations of this baseband coaxial system shall be compatible at the Medium Dependent Interface (MDI).

This standard provides one explicit trunk cable medium specification for the interconnection of all MAU devices. The medium itself, and the functional capability of the MAU, are defined to provide the highest possible level of compatibility among devices designed by different manufacturers. Designers are free to implement circuitry within the MAU in an application-dependent manner provided the MDI specifications are satisfied.

10.1.3.3 Relationship to PLS and AUI. This section defines the Primary Physical Layer for the local area network, a layer comprised of both the physical medium and the rudimentary circuitry necessary to couple a station's message path directly to/from the medium. The complete Logical Physical Layer of the local area network resides within the DTE. Therefore, a close relationship exists between this section and Section 7. This section specifies the physical medium parameters, the PMA logical functions residing in the MAU, and references the signal circuits associated with the AUI as defined in Section 7.

The design of a MAU component requires the use of both this section and parts of the PLS and AUI specifications contained in Section 7.

10.1.3.4 Mode of Operation. The MAU functions as a direct connection between the baseband medium and the DTE. Data from the DTE is output to the coaxial trunk medium and all data on the coaxial trunk medium is input to the DTE.

10.2 References. References to such local or national standards that may be useful resource material for the reader are identified and located in the Annex at the end of this book.

10.3 MAU Functional Specifications. The MAU component provides the means by which signals on the three AUI signal circuits to/from the DTE and their associated interlayer messages are coupled to the single coaxial cable baseband signal line. To achieve this basic objective, the MAU component contains the following functional capabilities to handle message flow between the DTE and the baseband medium:

- (1) Transmit Function. The ability to transmit serial data bit streams on the baseband medium from the local DTE entity to one or more remote DTE entities on the same network.
- (2) Receive Function. The ability to receive serial data bit streams over the baseband medium.
- (3) Collision Presence Function. The ability to detect the presence of two or more stations' concurrent transmissions.

- (4) Jabber Function. The ability to automatically interrupt the Transmit Function and inhibit an abnormally long output data stream.

10.3.1 MAU Physical Layer Functional Requirements

10.3.1.1 Transmit Function Requirements. At the start of a frame transmission on the coaxial cable, no more than 2 bits (2 full bit cells) of information may be received from the DO circuit and not transmitted onto the coaxial medium. In addition, it is permissible for the first bit sent to contain invalid data or timing; however, all successive bits of the frame shall be reproduced with no more than the specified amount of jitter. The 4th bit cell shall be carried from the DO signal line and transmitted onto the coaxial trunk cable medium with the correct timing and signal levels. The steady-state propagation delay between the DO circuit receiver input and the coaxial cable output shall not exceed 1/2 bit cell. There shall be no logical signal inversions between the branch cable DO circuit and the coaxial trunk cable (for example, a "high" logic level input to the MAU shall result in the less negative current flow value on the trunk coaxial medium). A positive signal on the A signal lead of the DO circuit shall result in a more positive voltage level on the trunk coaxial medium. It is assumed that the AUI shall provide adequate protection against noise. It is recommended that the designer provide an implementation in which a minimum threshold signal is required to establish a transmit bit stream.

The Transmit Function shall output a signal on the trunk coaxial medium whose levels and waveform comply with 10.4.1.3.

In addition, when the DO circuit has gone idle after a frame is output, the MAU shall then activate the Collision Presence Function as close to the trunk coaxial cable as possible without introducing an extraneous signal on the trunk coaxial medium. The MAU shall initiate the Collision Presence state within 0.6 μ s to 1.6 μ s after the Output Idle signal (Wait_Timer_Done in Fig 10-2) and shall maintain an active Collision Presence state for a time equivalent to 10 \pm 5 bit cells.

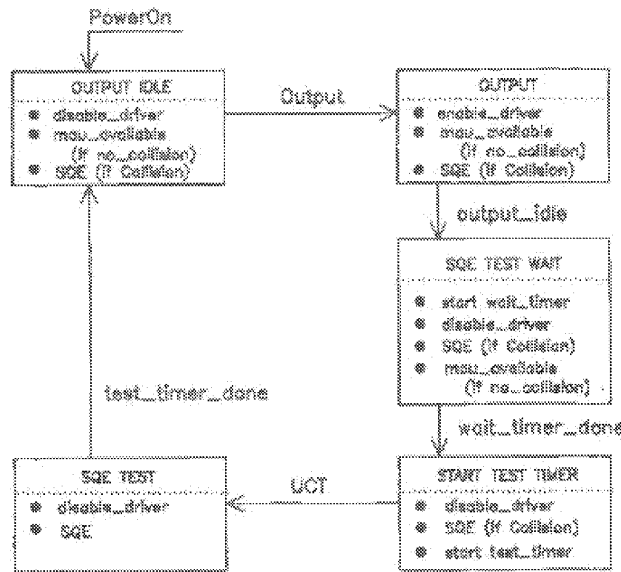

(UCT = unconditional transition)
(Wait_Timer_Done is specified in 10.3.1.1)

Fig 10-2
MAU Interface Function

10.3.1.2 Receive Function Requirements. The signal from the coaxial trunk cable shall be ac coupled before reaching the receive DI circuit. The Receive Function shall output a signal onto the DI circuit that complies with the specification for drivers in MAUs (7.5).

At the start of a frame reception from the coaxial cable, no more than 5 bits (5 full bit cells) of information may be received from the coaxial cable and not transmitted onto the receive DI circuit. In addition, it is permissible for the first bit sent over the receive circuit to contain invalid data or timing; however, all successive bits of the frame shall reproduce the incoming signal with no more than the amount of jitter specified below. This implies that the 7th bit cell presents valid data to the PLS. The steady-state propagation delay between the coaxial cable and the receive DI circuit output shall not exceed 1/2 bit cell. There are no logical signal inversions between the coaxial (trunk) cable and the MAU receive circuit.

A MAU meeting this specification shall exhibit edge jitter into the DI pair when terminated in the appropriate test load specified in 7.4.1.1, of no more than 7.0 ns in either direction when it is installed on the distant end of all lengths up to 185 m (600 ft) of the cable specified in 10.5.1.1 through 10.5.2.1.5 terminated at both ends with terminators meeting the impedance requirements of 10.6.2.1 and driven at one end with pseudorandom Manchester encoded binary data from a data generator that exhibits no more than 1.0 ns of edge jitter in either direction on half bit cells of exactly 1/2 BT and whose output meets the specifications of 10.4.1.3 except that the rise time of the signal shall be $30 \text{ ns} + 0, - 2 \text{ ns}$. The combination of coaxial cable and MAU receiver introduce no more than 6 ns of edge jitter into the system.

The local Transmit and Receive Functions shall operate simultaneously while connected to the medium.

10.3.1.3 Collision Presence Function Requirements. The signal presented to the CI circuit in the absence of a collision shall be the IDL signal.

The signal presented to the CI circuit during the presence of a collision shall be the CS0 signals encoded as specified in 7.3.1.2. This signal shall be presented to the CI circuit no more than 9 bit times after the signal (that is, dc average) on the coaxial cable at the MAU equals or exceeds that produced by two (or more) MAU outputs transmitting concurrently under the condition that the MAU detecting collision presence is transmitting. Under no conditions shall the Collision Presence Function generate an output when only one MAU is transmitting. A MAU, while not transmitting, may detect the presence of two other MAUs transmitting and shall detect the presence of more than two other MAUs transmitting. Table 10-1 summarizes the allowable conditions under which collisions shall be detected.

The collision presence function may, in some implementations, be able to sense an abnormal (for example, open) medium.

The use of MAUs in repeaters requires additional considerations; see 10.4.1.5

Table 10-1
Generation of Collision Presence Signal

MAU	Numbers of Transmitters		
	<2	=2	>2
Transmitting	N	Y	Y
Not Transmitting	N	May	Y

Y = will generate SQE message
N = will not generate SQE message
May = may generate SQE message

10.3.1.4 Jabber Functional Requirements. The MAU shall contain the capability as defined in Fig 10-3 to interrupt a transmission from a DO circuit that exceeds a time duration determined by the MAU. This time duration shall not be less than 20 ms nor more than 150 ms. If the frame being transmitted continues longer than the specified time duration, the MAU shall inhibit transmission and assume its not-transmitting state on the coaxial cable.

When the Transmit Function has been positively disabled, the MAU shall then activate the Collision Presence Function without introducing an extraneous signal on the trunk coaxial medium. A MAU may reset the Jabber and Collision Presence Functions on power reset once the error condition has been cleared. Alternately, a MAU may reset these functions automatically after a period of $0.5 \text{ s} \pm 50\%$.

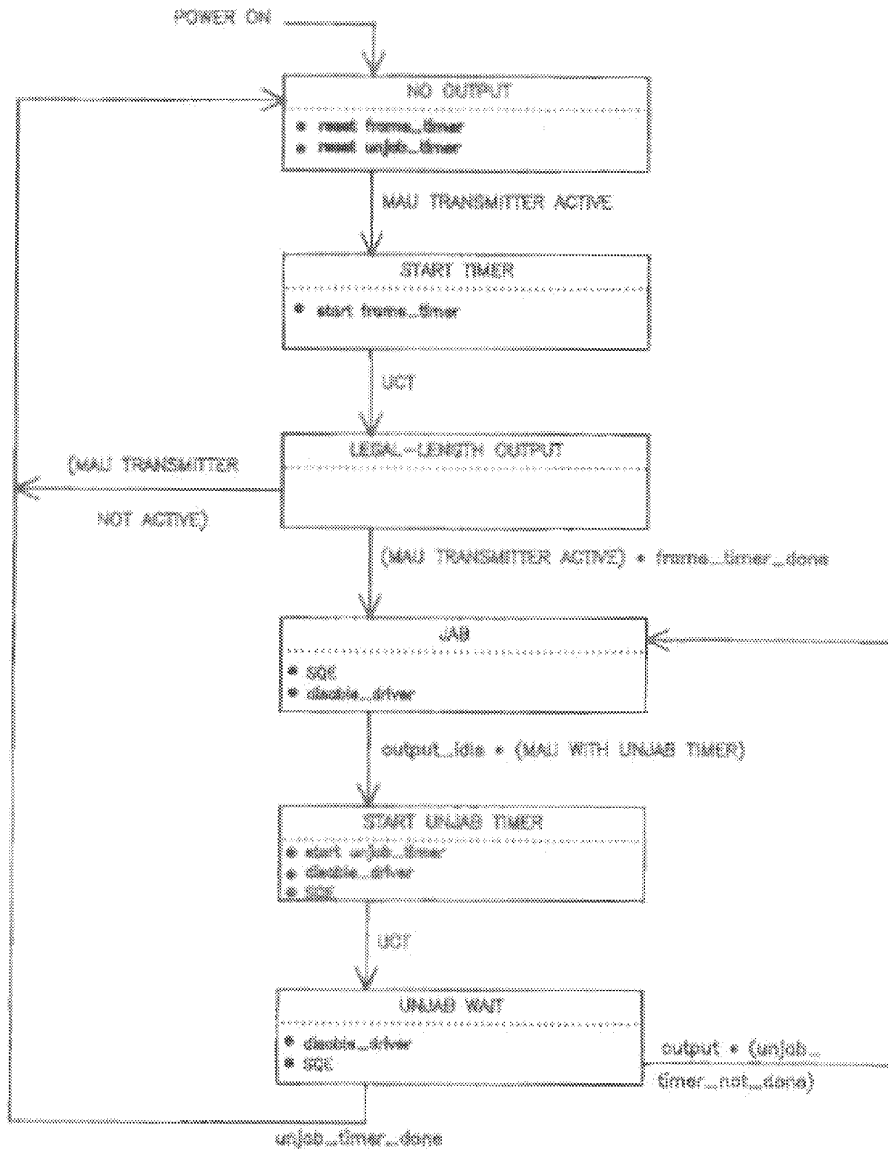

(Figure 10-3 outputs override those in Fig 10-2.
 Optional states: START UNJAB TIMER, UNJAB WAIT.)

Fig 10-3
 Jabber Function State Diagram

10.3.2 MAU Interface Messages

10.3.2.1 DTE to MAU Messages. The following messages can be sent by the DTE Physical Layer (PLS Sublayer) Entities to the MAU Entities:

Message	Circuit	Signal	Meaning
<i>output</i>	DO	CD1, CD0	Output information
<i>output_IDL</i>	DO	IDL	No data to be output

10.3.2.2 MAU to DTE Messages. The following messages can be sent by the MAU Physical Layer Entities to the DTE Physical Layer Entities:

Message	Circuit	Signal	Meaning
<i>input</i>	DI	CD1, CD0 [*]	Input information
<i>input_idle</i>	DI	IDL	No information to be input
<i>mau_available</i>	CI	IDL	MAU is available for output
<i>SQE</i>	CI	CSQ	Error detected by MAU

^{*}It is assumed that no retiming of these clocked data signals takes place within the MAU.

10.3.2.2.1 *input* Message. The MAU sends an input message to the DTE Physical Layer when the MAU has a bit of data to send to the DTE. The physical realization of the input message is a CD0 or CD1 sent by the MAU to the DTE on the Data In circuit. The MAU sends CD0 if the input bit is a zero or CD1 if the input bit is a one. No retiming of the CD1 or CD0 signals takes place within the MAU.

10.3.2.2.2 *input_idle* Message. The MAU sends an *input_idle* message to the DTE Physical Layer when the MAU does not have data to send to the DTE. The physical realization of the *input_idle* message is the IDL signal sent by the MAU to the DTE on the Data In circuit.

10.3.2.2.3 *mau_available* Message. The MAU sends the *mau_available* message to the DTE Physical Layer when the MAU is available for output. The *mau_available* message is always sent by a MAU that is always prepared to output data unless the *SQE* message should be sent instead. Such a MAU does not require *mau_request* to prepare itself for data output. The physical realization of the *mau_available* message is an IDL signal sent by the MAU to the DTE on the Control In circuit.

10.3.2.2.4 *signal_quality_error* (SQE) Message. The SQE message shall be implemented in the following fashion:

- (1) The SQE message shall not be sent by the MAU if no or only one MAU is transmitting on the trunk coaxial medium.
- (2) If more than two remote MAUs are transmitting on the trunk coaxial medium, but the MAU connected to the local DTE is not transmitting, then the local MAU shall send the SQE message. In every instance when more than one MAU is transmitting on the coaxial medium, the MAU shall make the best determination possible. It is acceptable for the MAU to fail to send the SQE message when it is unable to conclusively determine that more than one MAU is transmitting.
- (3) When the local MAU is transmitting on the trunk coaxial medium, all occurrences of one or more additional MAUs transmitting shall cause the SQE to be sent by the local MAU to its DTE.
- (4) When the MAU has completed each output frame it shall perform an SQE test sequence. Note that MAUs associated with repeaters shall not generate the SQE test sequence.
- (5) When the MAU has inhibited the Transmit Function, it shall send the SQE message in accordance with the Jabber Function requirements of 10.3.1.4 and Fig 10-3.

The SQE message shall be asserted less than 9 bit cells after the occurrence of the multiple-transmission condition is present at the Medium Dependent Interface (MDI) and shall no longer be asserted within 20 bit cells after the indication of multiple transmissions ceases to be present at the MDI. It is to be noted

that an extended delay in the removal of the SQE message may adversely affect the access method performance.

The physical realization of the SQE message is the CS0 signal sent by the MAU to the DTE physical layers on the Control In circuit.

NOTE: The MAU is required to assert the SQE at the appropriate times whenever the MAU is powered and not just when the DTE physical layer is providing data output.

10.3.3 MAU State Diagrams. The state diagrams, Figs 10-2 and 10-3, depict the full set of allowed MAU state functions relative to the control circuits of the DTE-MAU interface for MAUs without conditioning requirements. Messages used in these state diagrams are explained below:

enable_driver. Activates the path employed during normal operation to cause the MAU transmitter to impress data onto the trunk coaxial medium.

disable_driver. Deactivates the path employed during normal operation to cause the MAU transmitter to impress data onto the trunk coaxial medium.

no_collision. Signifies that the condition of multiple transmitters simultaneously active on the trunk coaxial medium does not exist.

collision. Signifies that the condition of multiple transmitters simultaneously active on the trunk coaxial medium does exist.

frame_timer. Measures the time the MAU transmits on the trunk coaxial cable.

test_timer. Measures the length of the SQE Test.

unjab_timer. Measures the amount of time the MAU has been in Jab mode.

wait_timer. Measures the time between output idle and the start of the SQE Test.

10.4 MAU-Medium Electrical Characteristics

10.4.1 MAU-to-Coaxial Cable Interface. The following subsections describe the interface between the MAU and the coaxial cable. Negative current is defined as current into the MAU (out of the center conductor of the cable).

10.4.1.1 Input Impedance. The shunt capacitance presented to the coaxial cable by the MAU circuitry (not including the means of attachment to the coaxial cable) is recommended to be not greater than 6 pF. The magnitude of the reflection from a MAU plus the cable connection specified in 10.6.3 shall not be more than that produced by an 6 pF capacitance when measured by both a 25 ns rise time and 25 ns fall time waveform. The resistance presented to the coaxial cable shall be greater than 100 k Ω .

These conditions shall be met in both the power-off and power-on, not-transmitting states.

10.4.1.2 Bias Current. The MAU must draw (from the cable) between +2 μ A and - 25 μ A in the power-off and the power-on, not-transmitting states.

10.4.1.3 Coaxial Cable Signaling Levels. The signal on the coaxial cable due to a single MAU as measured at the MAU's transmitter output is composed of an ac component and an offset component. Expressed in terms of current immediately adjacent to the MAU connection (just prior to splitting the current flow in each direction), the signal has an offset component (average dc current including the effects of timing distortion) of from - 37 mA min to - 45 mA max and an ac component from \pm 28 mA up to the offset value.

The current drive limit shall be met even in the presence of one other MAU transmitter. The MAU shall be capable of generating at least 2.2 V of average dc level on the coaxial cable in the presence of two or

more other MAUs transmitting concurrently. The MAU shall, in addition, sink no more than $\pm 250 \mu\text{A}$ when the voltage on the center conductor of the cable drops to -10 V when the MAU is transmitting.

The actual current measured at a given point on the cable is a function of the transmitted current and the cable loss to the point of measurement. Negative current is defined as current out of the center conductor of the cable (into the MAU). The 10–90% rise/fall times shall be $25 \pm 5 \text{ ns}$ at 10 Mb/s. The rise and fall times must match within 2 ns. Figure 10-4 shows typical waveforms present on the cable. Harmonic content generated from the 10 MHz fundamental periodic input shall meet the following requirements:

- Second and Third Harmonics: At least 20 dB below fundamental
- Fourth and Fifth Harmonics: At least 30 dB below fundamental
- Sixth and Seventh Harmonics: At least 40 dB below fundamental
- All Higher Harmonics: At least 50 dB below fundamental

NOTE: Even harmonics are typically much lower.

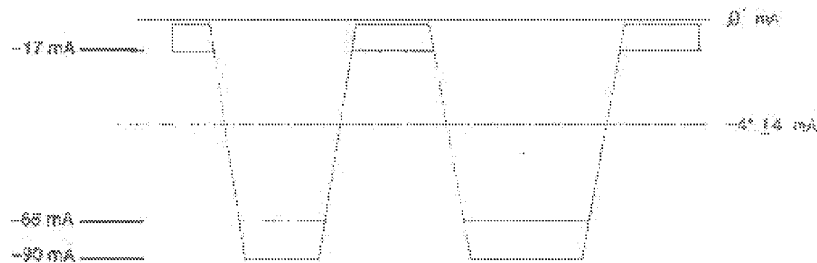
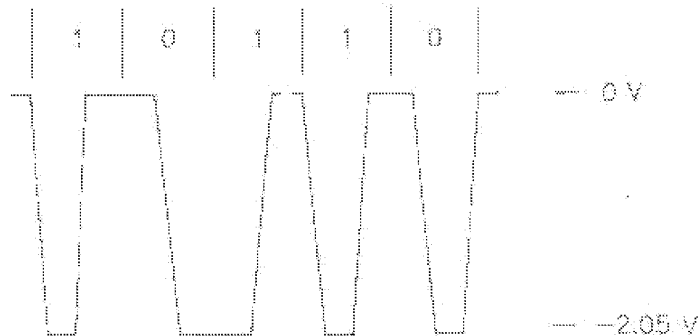

Fig 10-4
Driver Current Signal Levels

The above specifications concerning harmonics cannot be satisfied by a square wave with a single-pole filter, nor can they be satisfied by an output waveform generator employing linear ramps without additional waveshaping. The signals, as generated from the encoder within PLS, shall appear on the coaxial cable without any inversions (see Fig 10-5).



- NOTE: (1) Voltages given are nominal, for a single transmitter.
 (2) Rise time is 25 ns nominal at 10 Mb/s rate.
 (3) Voltages are measured on terminated coaxial cable adjacent to transmitting MAU.
 (4) Manchester coding.

Fig 10-5
Coaxial Trunk Cable Signal Waveform

10.4.1.4 Transmit Output Levels Symmetry. Signals received from the DO circuit must be transmitted onto the coaxial cable with the characteristics specified in 10.4.1.3. Since the coaxial cable proceeds in two directions from the MAU, the current into the MAU is nominally twice the current measured on the coaxial cable.

The output signal of a MAU meeting this specification shall exhibit edge jitter of no more than 2.5 ns into a $25 \Omega \pm 1\%$ resistor substituted for the connection to the coaxial cable when the DO circuit into the MAU is driven with pseudo-random Manchester encoded binary data from a data generator that exhibits no more than 0.5 ns of edge jitter on half bit cells of exactly 1/2 BT, whose output meets the specifications of 7.4.1.1 through 7.4.1.5. The above specified component shall not introduce more than 2 ns of edge jitter into the system.

The MAU shall not transmit a negative going edge after cessation of the CD output data stream or before the first valid edge of the next frame.

10.4.1.5 Collision Detect Thresholds. For receive mode collision detection the MAU shall have its collision detection threshold set in the range -1404 mV and -1581 mV. These limits take account of up to 8% collision detect filter impulse response. If a specific filter implementation has a higher value of impulse response, the lower threshold limit of -1404 mV is required to be replaced by 1300 mV \times [1 + impulse response].

Receive mode collision detection indicates that a nontransmitting MAU has the capability to detect collisions when two or more MAUs are transmitting simultaneously.

MAUs included with repeater sets are required to implement receive mode collision detection.

When receive mode collision detection is not implemented, the upper limit of -1581 mV may be relaxed to -1782 mV.

NOTE: The above threshold limits are measured at the coaxial cable center conductor with respect to the shield at the MAU connector. The MAU designer must take into account circuit offsets, low-frequency noise (for example, 50 Hz, 60 Hz), and 5 MHz ripple at the filter output in determining the actual internal threshold value and its tolerance.

10.4.2 MAU Electrical Characteristics

10.4.2.1 Electrical Isolation. The MAU must provide isolation between the DTE Physical Layer circuits and the coaxial trunk cable. The isolation impedance measured between any conductor in the DTE Physical Layer circuitry and either the center conductor or shield of the coaxial cable shall be greater than 250 k Ω at 50 Hz, 60 Hz. In addition, the isolation impedance between the DTE ground and the coaxial cable shield shall be less than 15 Ω between 3 MHz and 30 MHz. The isolation means provided shall withstand 300 V ac, rms for one minute.

10.4.2.2 Power Consumption. The current drawn by the MAU shall not exceed 0.5 A if powered by the AUI source. The MAU shall be capable of operating from all permissible voltage sources as supplied by the DTE through the resistance of all permissible AUI cables. The MAU shall not disrupt the trunk coaxial medium should the DTE power source fall below the minimum operational level under abnormal MAU load conditions.

The MAU shall be labeled externally to identify the maximum value of current required by the device. This requirement only applies to MAUs that are external to DTEs.

10.4.2.3 Reliability. The MAU shall be designed to provide an MTBF of at least 100 000 hours of continuous operation without causing communication failure among other stations attached to the local network medium. Component failures within the MAU electronics should not impede the communication among other MAUs on the coaxial cable. Connectors and other passive components comprising the means of connecting the MAU to the coaxial cable shall be designed to minimize the probability of total network failure.

It should be noted that a fault condition that causes a MAU to draw in excess of 2 mA from the coaxial cable may cause communication failure among other stations.

10.4.3 MAU-DTE Electrical Characteristics. If the AUI is exposed, the electrical characteristics for the driver and receiver components connected between the DTE Physical Layer circuitry and the MAU shall be identical with those as specified in Section 7 of this standard.

10.5 Characteristics of Coaxial Cable System. The trunk cable is of constant impedance, coaxial construction. It is terminated at each of the two ends by a terminator (see 10.6.2), and provides the transmission path for connection of MAU devices. Coaxial cable connectors are used to make the connection from the cable to the terminators and between cable sections. The cable has various electrical and mechanical requirements that shall be met to ensure proper operation.

10.5.1 Coaxial Cable Electrical Parameters. The parameters specified in 10.5.1 are met by cable types RG 58 A/U or RG 58 C/U.

10.5.1.1 Characteristic Impedance. The average characteristic cable impedance shall be $50 \pm 2 \Omega$. Periodic variations in impedance along a single piece of cable may be up to $\pm 3 \Omega$ sinusoidal, centered around the average value, with a period of less than 2 m.

10.5.1.2 Attenuation. The attenuation of a 185 m (600 ft) cable segment shall not exceed 8.5 dB measured at 10 MHz, or 6.0 dB measured at 5 MHz.

10.5.1.3 Velocity of Propagation. The minimum required velocity of propagation is 0.65 c.

10.5.1.4 Edge Jitter; Entire Segment without DTEs Attached. A coaxial cable segment meeting this specification shall exhibit edge jitter of no more than 8.0 ns in either direction at the receiving end when 185 m (600 ft) of the cable is terminated at both ends with terminators meeting the impedance requirements of 10.6.2.1 and is driven at one end with pseudorandom Manchester encoded binary data from a data generator that exhibits no more than 1.0 ns of edge jitter in either direction on half bit cells of exactly $\frac{1}{2}$ BT and whose output meets the specifications of 10.4.1.3, except that the rise time of the signal must be $30 \text{ ns} + 0, - 2 \text{ ns}$, and no offset component in the output current is required. This test shall be conducted in a noise-free environment. The above specified component is not to introduce more than 7 ns of edge jitter into the system.

10.5.1.5 Transfer Impedance. The coaxial cable medium shall provide sufficient shielding capability to minimize its susceptibility to external noise and also to minimize the generation of interference by the medium and related signals. While the cable construction is not mandated, it is necessary to indicate a measure of performance expected from the cable component. A cable's EMC performance is determined, to a large extent, by the transfer impedance value of the cable.

The transfer impedance of the cable shall not exceed the values shown in Fig 10-6 as a function of frequency.

10.5.1.6 Cable DC Loop Resistance. The sum of the center conductor resistance plus the shield resistance measured at 20 °C shall not exceed 50 m Ω /m.

10.5.2 Coaxial Cable Physical Parameters

10.5.2.1 Mechanical Requirements. The cable used should be suitable for routing in various environments, including but not limited to, dropped ceilings, raised floors, and cable troughs as well as throughout open floor space. The jacket shall provide insulation between the cable sheath and any building structural metal. Also, the cable shall be capable of accepting coaxial cable connectors, described in 10.6. The cable shall conform to the following requirements.

10.5.2.1.1 General Construction

- (1) The coaxial cable shall consist of a center conductor, dielectric, shield system, and overall insulating jacket.
- (2) The coaxial cable shall be sufficiently flexible to support a bend radius of 5 cm.

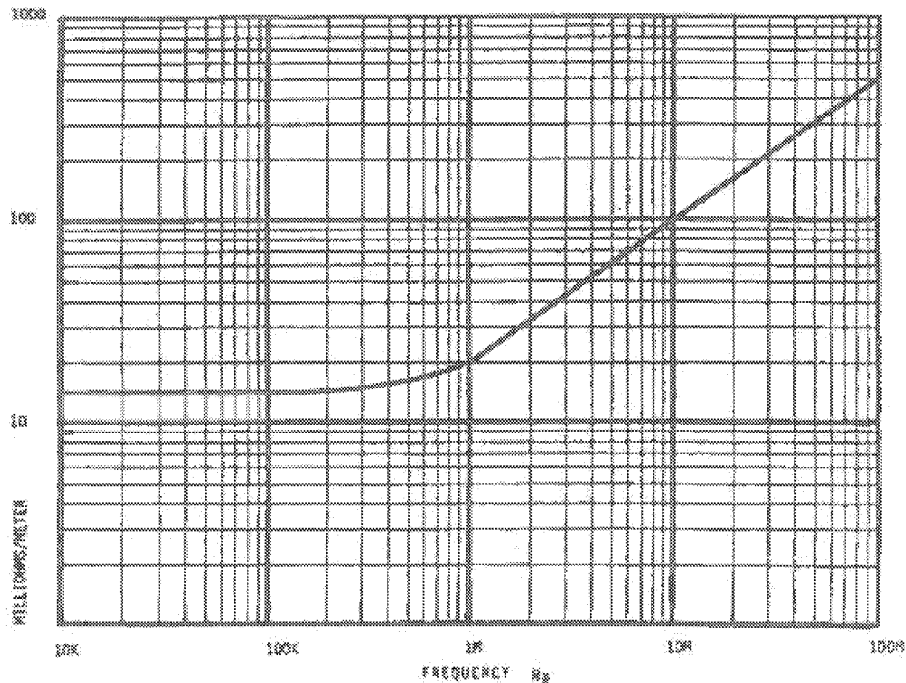

Fig 10-6
Maximum Coaxial Cable Transfer Impedance

10.5.2.1.2 Center Conductor. The center conductor shall be stranded, tinned copper with an overall diameter of $0.89 \text{ mm} \pm 0.05 \text{ mm}$.

10.5.2.1.3 Dielectric Material. The dielectric may be of any type, provided that the conditions of 10.5.1.2 and 10.5.1.8 are met; however, a solid dielectric is preferred.

10.5.2.1.4 Shielding System. The shielding system may contain both braid and foil elements sufficient to meet the transfer impedance of 10.5.1.5 and the EMC specifications of 10.8.2.

The inside diameter of the shielding system shall be $2.95 \text{ mm} \pm 0.15 \text{ mm}$.

The shielding system shall be greater than 95% coverage. The use of tinned copper braid is recommended to meet the contact resistance and shielding requirements.

10.5.2.1.5 Overall Jacket

- (1) Any one of several jacket materials shall be used provided the specifications of 10.5.1 and 10.5.2 are met.
- (2) Either of two jacket dimensions may be used for the two broad classes of materials provided the specification of 10.5.2.1.1 are met:
 - (a) Polyvinyl chloride (for example, PVC) or equivalent having an OD of $4.9 \text{ mm} \pm 0.3 \text{ mm}$.
 - (b) Fluoropolymer (for example, FEP, ECTFE) or equivalent having an OD of $4.8 \text{ mm} \pm 0.3 \text{ mm}$.

The cable shall meet applicable flammability and smoke criteria to meet the local and national codes for the installed environment (see 10.8.3).

Different types of cable sections (for example, polyvinyl chloride and fluoropolymer dielectric) may be interconnected, while meeting the sectioning requirements of 10.7.2.1.

10.5.2.2 Jacket Marking. It is recommended that the cable jacket be marked with manufacturer and type at a nominal frequency of at least once per meter along the cable.

10.5.3 Total Segment DC Loop Resistance. The sum of the center conductor, connectors, and shield resistance shall not exceed 10 Ω total per segment. Each in-line connector pair or MAU shall contribute no more than 10 m Ω .

As a trunk coaxial cable segment consists of several cable sections, all connectors and internal resistance of the shield and center conductor shall be included in the loop resistance measurement.

10.6 Coaxial Trunk Cable Connectors. The trunk coaxial medium requires termination and is partitioned into sections. Devices to be attached to the medium require a means of connection to the medium. This means is provided by a BNC "T" adapter, as shown in Fig 10-7.

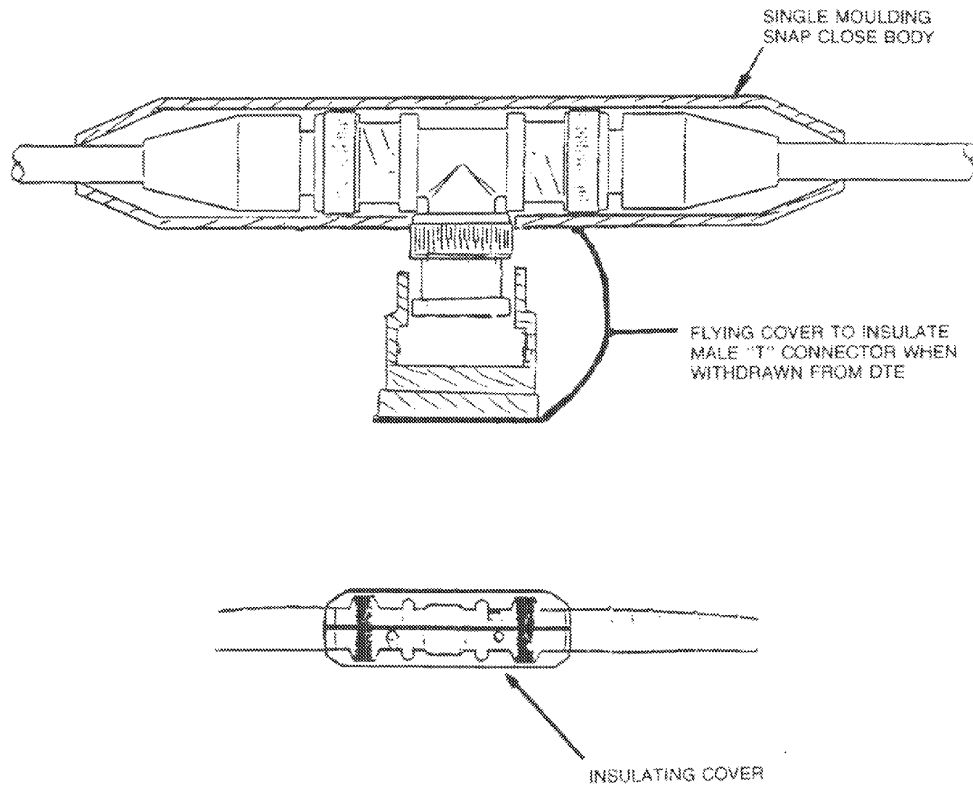

(Tutorial only and not part of the standard.)

Fig 10-7
Examples of Insulated Connector Cover

The BNC connectors shall be of the 50 Ω constant impedance type. High-quality versions of these connectors (per IEC 169-8 [4]) are recommended in order to meet dc loop resistance and reliability considerations. All of the coaxial connectors shall follow the requirements as defined in 10.6.3.

10.6.1 In-Line Coaxial Extension Connector: All coaxial cables shall be terminated with BNC plug connectors. A means shall be provided to ensure that the connector shell (which connects to the cable sheath) does not make contact with any building metal (at ground potential) or other unintended conductor.

An insulating sleeve or boot slipped over the connector at installation time is suitable.

In-line coaxial extensions shall be made with BNC receptacle-to-receptacle connectors joined together to form one "barrel." An insulating sleeve or boot shall also be provided with each barrel assembly.

10.6.2 Coaxial Cable Terminator

10.6.2.1 Coaxial cable terminators are used to provide a termination impedance for the cable equal in value to its characteristic impedance, thereby minimizing reflection from the ends of the cables. Terminators shall be packaged within a male or female connector. The termination impedance shall be $50 \Omega \pm 1\%$ measured from 0–20 MHz, with the magnitude of the phase angle of the impedance not to exceed 5° . The terminator power rating shall be 0.5 W or greater. A means of insulation shall be provided with each terminator.

10.6.3 MAU-to-Coaxial Cable Connection. A BNC "T" (plug, receptacle, plug) adaptor provides a means of attaching a MAU to the coaxial cable. The connection shall not disturb the transmission line characteristics of the cable significantly; it shall present a low shunt capacitance, and therefore a negligibly short stub length. This is facilitated by the MAU being located as close to its cable connection as possible; the MAU and connector are normally considered to be one assembly. Long (greater than 4 cm) connections between the coaxial cable and the input of the MAU jeopardize this objective.

Overall system performance is dependent largely on the MAU-to-coaxial cable connection being of low shunt capacitance.

The design of the connection shall meet the electrical requirements contained in 10.4.1.1 and the reliability specified in 10.4.2.3. The use of BNC "T" adaptors and connectors satisfies these requirements. Figure 10-7 shows a MAU-to-coaxial cable attachment.

A means shall be provided to ensure that the connector assembly (that is, BNC "T" plus male connectors) does not make contact with any building metalwork (at ground potential) or any other unintended conductors. An insulating cover should therefore be applied after connection. A possible design is depicted in Fig 10-7. The insulating cover should have these characteristics:

- (1) It should guard against accidental grounding of the connector assembly.
- (2) It should allow ease of attachment and detachment of an assembled "T" connector to the MAU without necessitating the removal of section cable connectors (that is, segment integrity is maintained).
- (3) It should be a simple moulding that attaches firmly to a connector assembly.

10.7 System Considerations

10.7.1 Transmission System Model. Certain physical limits have been placed on the physical transmission system. These revolve mostly around maximum cable lengths (or maximum propagation times), as these can affect critical time values for the CSMA/CD access method. These maxima, in terms of propagation times, were derived from the physical configuration model described here. The maximum configuration is as follows:

- (1) A trunk coaxial cable, terminated in its characteristic impedance at each end, constitutes a coaxial segment. A coaxial segment may contain a maximum of 185 m (600 ft) of coaxial cable and a maximum of 30 MAUs. The propagation velocity of the coaxial cable is assumed to be 0.65 c minimum ($c = 3 \times 10^8$ m/s). The maximum end-to-end propagation delay for a coaxial segment is 950 ns.
- (2) Repeater sets are required for segment interconnection. Repeater sets occupy MAU positions on coaxial segments and count toward the maximum number of MAUs on a coaxial segment. Repeater sets may be located anywhere on a coaxial segment.
- (3) The maximum transmission path permitted between any two MAUs is limited by the number of repeater sets that can be connected in series (that is, four). The maximum number of segments connected in series is therefore five (Fig 10-8), which shall consist of no more than three tapped coaxial segments; the remainder shall be link segments as defined in 5.6.1.

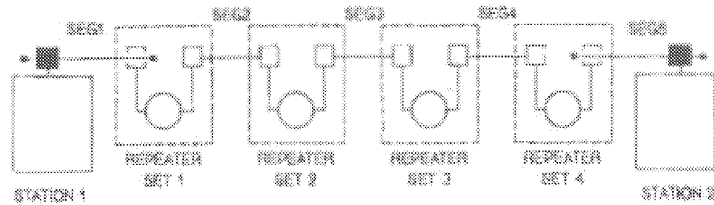

Fig 10-8
Maximum Transmission Path

NOTE: Care should be taken to ensure that the safety requirements are met when extending the trunk cable by the use of repeaters (see 10.7.3.2).

- (4) The transmission system may also contain segments comprising trunk coaxial cable specified in Section 8; however, these shall be attached by repeater sets. As such a combination of segments is capable of achieving longer lengths than (3) above, the maximum configuration then becomes limited by propagation delay. Type 10BASE2 segments should not be used to bridge two Type 10BASE5 segments.

Figures 10-9, 10-10, and 10-11 show transmission systems of various types and sizes to illustrate the boundary conditions on topologies generated according to the specifications in this section.

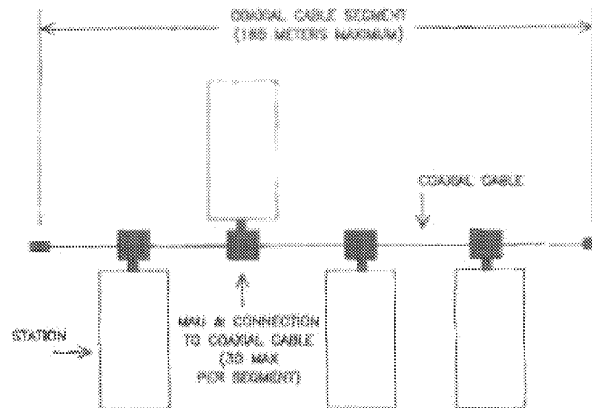

Fig 10-9
The Minimum System Configuration

10.7.2 Transmission System Requirements

10.7.2.1 Cable Sectioning. The 185 m (600 ft) maximum length coaxial cable segment will be made from a number of cable sections. As the variation on cable characteristic impedance is $\pm 2 \Omega$ on 50Ω , a possible worst-case reflection of 4% may result from the mismatch between two adjacent cable sections. The MAU will add to this reflection by the introduction of its noninfinite bridging impedance.

The accumulation of this reflection can be minimized by observing a minimum distance between MAUs (and between cable sections). In order to maintain reflections at an acceptable level, the minimum length cable section shall be 0.5 m.

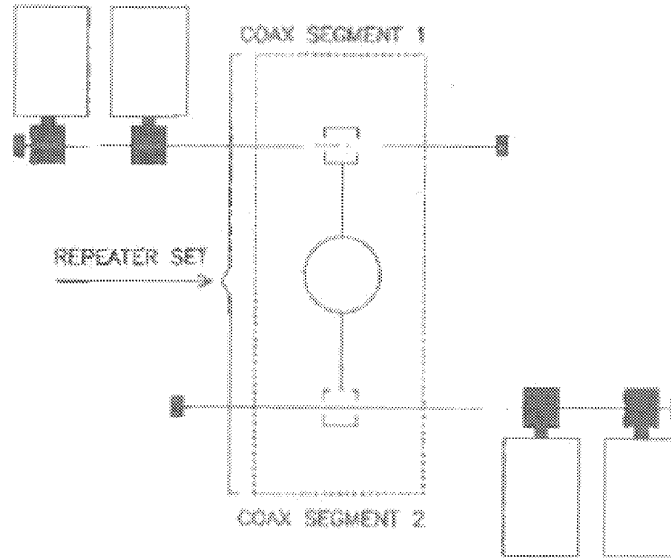

Fig 10-10
The Minimum System Configuration Requiring a Repeater Set

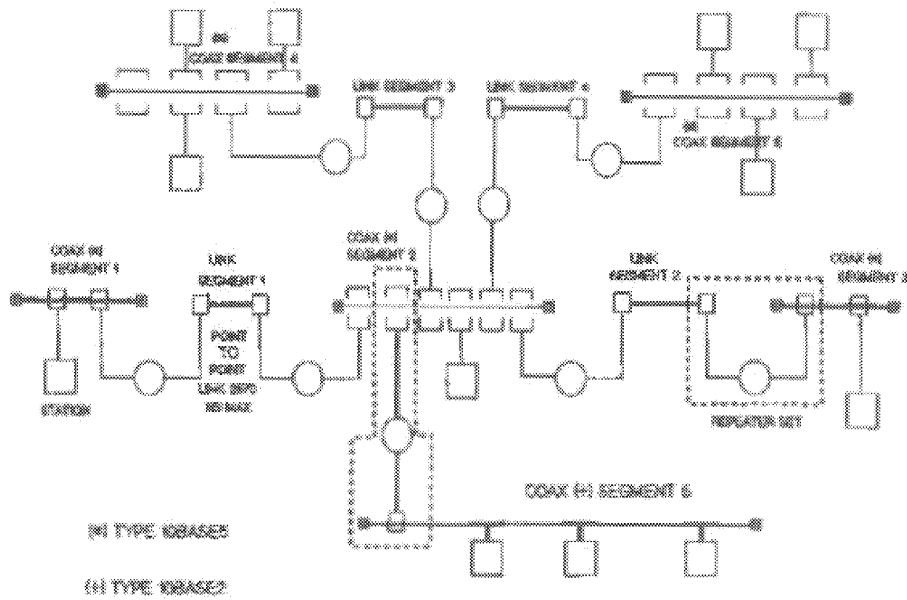

Fig 10-11
An Example of a Large Hybrid System

10.7.2.2 MAU Placement. MAU components and their associated connections to the cable cause signal reflections due to their noninfinite bridging impedance. While this impedance must be implemented as specified in 10.6, the placement of MAUs along the coaxial cable must also be controlled to ensure that reflections from the MAU do not accumulate to a significant degree.

Coaxial cable sections as specified in 10.7.2.1 shall be used to connect MAUs. This guarantees a minimum spacing between MAUs of 0.5 m.

The total number of MAUs on a cable segment shall not exceed 30.

10.7.2.3 Trunk Cable System Earthing. The shield conductor of each coaxial cable segment may make electrical contact with an effective earth reference¹³ at one point and shall not make electrical contact with earth elsewhere on such objects as building structural metal, ducting, plumbing fixture, or other unintended conductor. Insulators should be used to cover any coaxial connectors used to join cable sections and terminators, to ensure that this requirement is met. A sleeve or boot attached at installation time is acceptable. (See 10.6.3.)

10.7.2.4 Static Discharge Path. A static discharge path shall be provided. The shield of the trunk coaxial cable is required to be connected to each DTE earth (within the DTE) via a 1 M Ω , 0.25 W resistor that has a voltage rating of at least 750 V dc.

10.7.2.5 Installation Environment. This specification is intended for networks in use within a single building and within an area served by a single low-voltage power distribution system. Applications requiring interplant connections via external (outdoors) means may require special considerations. Repeaters and nonconducting IRL components may provide the means to satisfy these isolation requirements.

NOTE: The reader is advised that devices should not be operated at significantly different frame potentials. The 10BASE2 connection system may not be capable of handling excessive earth currents.

10.8 Environmental Specifications

10.8.1 Safety Requirements. The designer should consult relevant local and national safety regulations to assure compliance with the appropriate standards (for example, see Appendix A for reference material).

10.8.1.1 Installations. If the trunk coaxial cable is to be installed in close proximity to electrical power cables, then installation practice according to local and national code shall be followed (see Annex for resource material).

10.8.1.2 Earthing. Where earthing is mandated by locally or nationally prescribed codes of practice, the shield of the trunk coaxial cable shall be effectively earthed at only one point along the length of the cable. Effectively earthed means permanently connected to earth through an earth connection of sufficiently low impedance and having sufficient ampacity to prevent the building up of voltages that may result in undue hazard to connected equipment or to persons.

10.8.2 Electromagnetic Environment

10.8.2.1 Susceptibility Levels. Sources of interference from the environment include electromagnetic fields, electrostatic discharge, transient voltages between earth connections, etc.

Several sources of interference will contribute to voltage buildup between the coaxial cable and the earth connection of a DTE.

The physical channel hardware shall meet its specifications when operating in either of the following conditions:

- (1) Ambient plane wave field of 1 V/m from 10 kHz through 1 GHz.

NOTE: Levels typically >1 km from broadcast stations.

¹³See local or national regulations for guidance on these matters and reference [A.12].

- (2) Interference source voltage of 15.10 V peak 10 MHz sine wave with a 50 Ω source resistance applied between the coaxial cable shield and the DTE ground connection.

MAUs meeting this standard should provide adequate RF ground return (coaxial cable shield to DTE ground) to satisfy the referenced EMC specifications.

10.8.2.3 Emission Levels. The physical MAU and trunk cable system shall comply with local and national regulations (see Annex for resource material).

10.8.3 Regulatory Requirements. The MAU and medium should consider IEC 435 in addition to local and national regulations. See references [6] and [A12].

11. Broadband Medium Attachment Unit and Broadband Medium Specifications, Type 10BROAD36

11.1 Scope

11.1.1 Overview. This section defines the functional, electrical, and mechanical characteristics of the Broadband Medium Attachment Unit (MAU) and the specific single- and dual-cable broadband media for use with local area networks. The headend frequency translator for single-cable broadband systems is also defined. The relationship of this specification to all of the IEEE Local Area Network standards (IEEE 802) is shown in Fig 11-1. Repeaters as defined in Section 9 are not relevant for 10BROAD36.

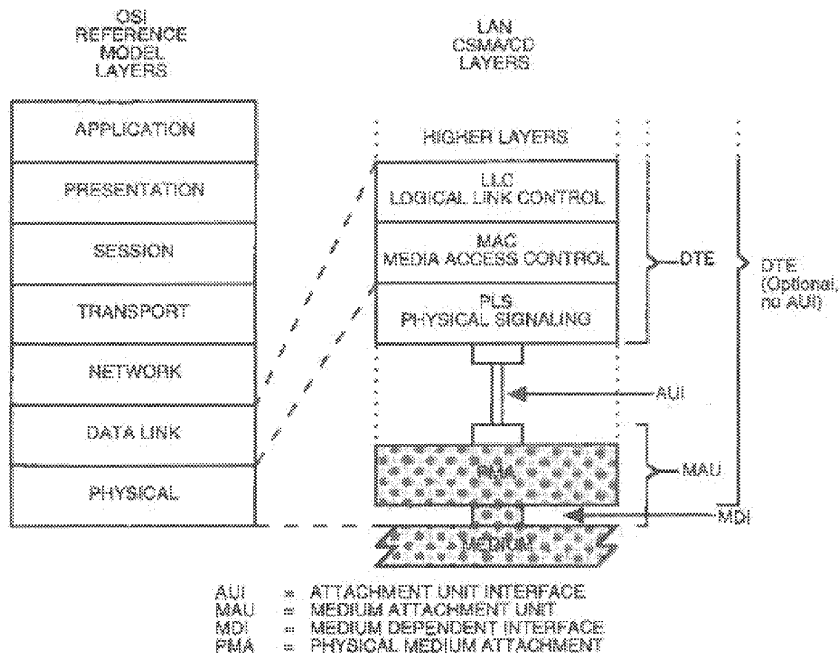

Fig 11-1

Physical Layer Partitioning, Relationship to the ISO Open Systems Interconnection (OSI) Reference Model

The purpose of the MAU is to provide a means of attaching devices to a broadband local network medium. The medium comprises CATV-type cable, taps, connectors, and amplifiers. A coaxial broadband system permits the assignment of different frequency bands to multiple applications. For example, a band in the spectrum can be utilized by local area networks while other bands are used by point-to-point or multipoint links, television, or audio signals.

The physical tap is a passive directional device such that the MAU transmission is directed toward the headend location (reverse direction). On a single-cable system the transmission from the MAU is at a carrier frequency f_1 . A frequency translator (or remodulator) located at the headend up-converts to a carrier frequency f_2 , which is sent in the forward direction to the taps (receiver inputs). On a dual-cable system the transmit and receive carrier frequencies are identical (both f_1) and the MAU connects to the medium via two taps, one on the receive cable and the other on the transmit cable. The transmit and receive cables are connected to each other at the headend location. Figure 11-2 shows broadband single- and dual-cable systems.

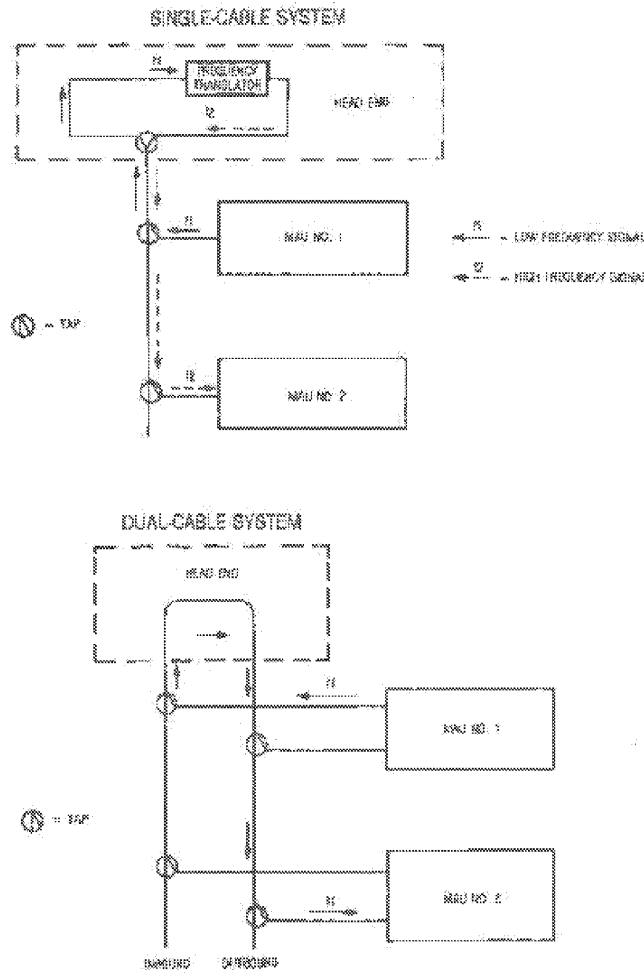

Fig 11-2
Broadband Cable Systems

The broadband MAU operates by accepting data from the attached Data Termination Equipment (DTE) and transmitting a modulated radio frequency (RF) data signal in a data band on the broadband coaxial cable system. All MAUs attached to the cable system receive and demodulate this RF signal and recover the DTE data. The broadband MAU emulates a baseband MAU except for delay between transmission and reception, which is inherent in the broadband cable system.

A transmitting MAU logically compares the beginning of the received data with the data transmitted. Any difference between them, which may be due to errors caused by colliding transmissions, or reception of an earlier transmission from another MAU, or a bit error on the channel, is interpreted as a collision.

When a collision is recognized, the MAU stops transmission in the data band and begins transmission of an RF collision enforcement (CE) signal in a separate CE band adjacent to the data band. The CE signal is detected by all MAUs and informs them that a collision has occurred. All MAUs signal to their attached Medium Access Controllers (MACs) the presence of the collision. The transmitting MACs then begin the collision handling process.

Collision enforcement is necessary because RF data signals from different MAUs on the broadband cable system may be received at different power levels. During a collision between RF signals at different

levels, the MAU with the higher received power level may see no errors in the detected data stream. However, the MAU with the lower RF signal will see a difference between transmitted and received data; this MAU transmits the CE signal to force recognition of the collision by all transmitting MAUs.

11.1.2 Definitions

Attachment Unit Interface (AUI). In a local area network, the interface between the medium attachment unit and the DTE within a data station. Note that the AUI carries encoded signals and provides for duplex data transmission.

Binary Phase Shift Keying (Binary PSK or BPSK). A form of modulation in which binary data are transmitted by changing the carrier phase by 180 degrees.

Broadband LAN. A Local Area Network in which information is transmitted on modulated carriers, allowing coexistence of multiple simultaneous services on a single physical medium by frequency division multiplexing.

CATV-Type Broadband Medium. A broadband system comprising coaxial cables, taps, splitters, amplifiers, and connectors the same as those used in Community Antenna Television (CATV) or cable television installations.

Channel. A band of frequencies dedicated to a certain service transmitted on the broadband medium.

Coaxial Cable. A two conductor, concentric (center conductor and shield), constant impedance transmission line.

Continuous Wave (CW). A carrier that is not modulated or switched.

dBmV. Decibels referenced to 1.0 mV on 75 Ω , used to define signal levels in CATV-type broadband systems.

Drop Cable. The small diameter flexible coaxial cable of the broadband medium that connects to a Medium Access Unit (MAU). See **Trunk Cable**.

Group Delay. The rate of change of total phase shift, with respect to frequency, through a component or system. Group delay variation is the maximum difference in group delay over a band of frequencies.

Headend. The location in a broadband system that serves as the root for the branching tree comprising the physical medium; the point to which all inbound signals converge and the point from which all outbound signals emanate.

Jabber. A condition wherein a station transmits for a period of time longer than the maximum permissible packet length, usually due to a fault condition.

Postamble. In the broadband Medium Attachment Unit specified in this section, the bit pattern appended after the last bit of the Frame Check Sequence; the Broadband End-of-Frame Delimiter (BEOFD).

Return Loss. The ratio in decibels of the power reflected from a port to the power incident to the port. An indicator of impedance matching in a broadband system.

Seed. The twenty-three (23) bits residing in the scrambler shift register prior to the transmission of a packet.

Spectrum Mask. A graphic representation of the required power distribution as a function of frequency for a modulated transmission.

Translation. In a single-cable system, the process by which incoming transmissions at one frequency are converted to another frequency for outgoing transmission. The translation takes place at the headend.

Truncation Loss. In a modulated data waveform, the power difference before and after implementing the filtering necessary to constrain its spectrum to a specified frequency band.

Trunk Cable. The main (large-diameter) cable of a broadband coaxial cable system. See **Drop Cable**.

11.13 MAU and Medium Objectives. This subsection states the broad objectives and assumptions underlying the specifications defined throughout this section of the standard.

- (1) Provide the physical means for communication among local network Data Link Entities using a broadband coaxial medium.
- (2) Provide a broadband Medium Attachment Unit (MAU) that is compatible at the Attachment Unit Interface (AUI) with DTEs used on a baseband medium.
- (3) Provide a broadband MAU that emulates the baseband MAU except for the signal delay from Circuit DO to Circuit DI.
- (4) Provide a broadband MAU that detects collisions within the timing constraints specified in the baseband case.
- (5) Provide a broadband network diameter no less than 2600 m.
- (6) Provide a broadband Physical Layer that ensures that no MAU is allowed to capture the medium during a collision due to signal level advantage (that is, ensures fairness of the physical layer).
- (7) Provide a broadband MAU that detects collisions in both receive and transmit modes.
- (8) Provide a broadband MAU that requires a transmission bandwidth no wider than 18 MHz.
- (9) Define a physical interface that can be implemented independently among different manufacturers of hardware and achieve the intended level of compatibility when interconnected in a common broadband local area network.
- (10) Provide a communication channel capable of high bandwidth and low bit error rate performance. The resultant mean bit error rate at the physical layer service interface should be less than one part in 10^8 (on the order of one part in 10^9 at the link level) in a worst-case signal-to-noise ratio of 26 dB.
- (11) Provide a broadband medium physical layer that allows for implementation in both dual- and single-cable systems.
- (12) Provide for ease of installation and service.
- (13) Provide a communication channel that coexists with other channels on the same physical medium.

It is not an objective of this broadband MAU to allow its use with the baseband repeater defined in Section 9 of this standard.

11.14 Compatibility Considerations. All implementations of the broadband coaxial system shall be compatible at the Medium Dependent Interface (MDI). This standard provides medium specifications for the interconnection of all MAU devices. The medium itself, the functional capability of the MAU and the AU Interface are defined to provide the highest possible level of compatibility among devices designed by different manufacturers. Designers are free to implement circuitry within the MAU in an application-dependent manner provided the MDI and AUI specifications are satisfied. Subsystems based on this specification may be implemented in several different ways provided compatibility at the medium is maintained. It is possible, for example, to design an integrated station where the MAU is contained within a physical DTE system component, thereby eliminating the AUI cable.

11.15 Relationship to PLS and AUI. The broadband MAU and cable system specifications are closely related to Section 7 (Physical Signaling and Attachment Unit Interface Specifications). The design of a physical MAU component requires the use of both this section and the PLS and AUI specifications in Section 7.

11.16 Mode of Operation. In its normal mode of operation, the MAU functions as a direct connection between the DTE and the broadband medium. Data from the DTE are transmitted onto the broadband coaxial system and all inband data on the coaxial cable system is received by the DTE. This mode is the

mode of operation for the intended message traffic between stations. Other operating modes, such as a loopback mode or a monitor mode, may be provided but are not defined by this standard.

11.2 MAU Functional Specifications

11.2.1 MAU Functional Requirements. The MAU component provides the means by which signals on the physically separate AUI signal circuits to and from the DTE and their associated interlayer messages are coupled to the broadband coaxial medium. To achieve this basic objective, the MAU component contains the following capabilities to handle message flow between the DTE and the broadband medium:

- (1) **Transmit Function.** The ability to transmit serial data bit streams originating at the local DTE in a band-limited modulated RF carrier form, to one or more remote DTEs on the same network.
- (2) **Receive Function.** The ability to receive a modulated RF data signal in the band of interest from the broadband coaxial medium and demodulate it into a serial bit stream.
- (3) **Collision Presence Function.** The ability to detect the presence of two or more stations' concurrent transmissions.
- (4) **Jabber Function.** The ability of the MAU itself to interrupt the transmit function and inhibit an abnormally long output data stream.

11.2.1.1 Transmit Function Requirements. The transmit function shall include the following capabilities:

- (1) Receive Manchester encoded data sent by the local DTE to the attached MAU on Circuit DO (transmit data pair).
- (2) Decode the Manchester encoded data received on Circuit DO to produce NRZ (Non-Return to Zero) data and a recovered clock signal.
- (3) Scramble the NRZ data using a CCITT V.29-type scrambler with seed changed on each transmitted packet.
- (4) Transform the incoming bits (prior to modulation) to provide an unscrambled alternating zero-one pattern terminated by an Unscrambled Mark Delimiter (UMD); scramble the remainder of the incoming preamble, Start Frame Delimiter (SFD), and data frame, and append an unscrambled postamble (Broadband End of Frame Delimiter [BEOFD]).
- (5) Differentially encode the packet generated above.
- (6) Produce a bandlimited, double sideband suppressed carrier, binary FSK modulated RF signal representing the above generated differentially encoded packet.
- (7) Drive the coaxial cable with the modulated RF signal.

Figure 11-3 functionally represents these capabilities. The order of the functional blocks may be altered provided that the result is the same.

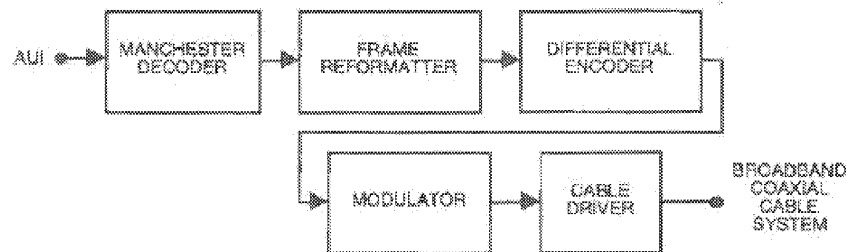

Fig 11-3
Transmit Function Requirements

11.2.1.2 Receive Function Requirements. The receive function shall include the following:

- (1) Receive the differentially encoded binary PSK modulated RF signal from the broadband coaxial medium.
- (2) Receive the data band RF signals and reject signals in bands other than the data band (rejection of signals in the adjacent collision enforcement band is optional).
- (3) Demodulate and differentially decode the incoming RF data signal from the coaxial medium to provide a receive bit stream that represents the scrambled bit stream at the transmitter.
- (4) Descramble the receive bit stream using a self-synchronizing descrambler.
- (5) Manchester encode the descrambled bit stream.
- (6) Send to the DTE, using Circuit DI (receive data pair), an additional, locally-generated, Manchester encoded preamble equal to the number of preamble bits lost in the receive data path (plus or minus one bit), followed by the Manchester encoded bit stream. No more than 6 preamble bits may be lost from the preamble presented to Circuit DO at the transmitting MAU.
- (7) Detect end of frame, using the postamble (BROFD), and ensure that no extraneous bits are sent to the DTE on Circuit DI.
- (8) Receive signals in the collision enforcement band and reject signals in the data band and all other bands on the broadband medium.

11.2.1.3 Collision Detection Function Requirements. The MAU shall perform the following functions to meet the collision detection requirements:

- (1) Store the scrambled bits (not differentially encoded) in the transmit section through to the last bit in the source address.
- (2) Detect the UMD in the transmit and receive paths.
- (3) Compare received scrambled bits after the received UMD with transmitted scrambled bits after the transmit UMD through to the last bit in the source address.
- (4) A Receive UMD Timer function shall be performed by the MAU. The timer shall be as long as the time required from initial detection of RF data signal presence to detection of a UMD in a normally received (no collision) packet.
- (5) Enter a LOCAL COLLISION DETECTION state if one of the following occurs:
 - (a) A bit error is found in the bit compare process through the last bit in the source address.
 - (b) The Receive UMD Timer expires before a UMD is detected in the received bit stream.
 - (c) The MAU receives the *output* (that is, transmit) signal from the AUI AFTER having received an RF signal from the coaxial cable.
- (6) Upon entering the LOCAL COLLISION DET state, cease transmission in the data band and commence transmission in the collision enforcement band for as long as the DTE continues to send data to the MAU.
- (7) Upon entering the LOCAL COLLISION DET state send the *signal_quality_error* (SQE) message on Circuit CI (collision presence pair) using the CS0 signal for as long as RF signals are detected on the broadband coaxial medium in either the data or collision enforcement bands.
- (8) Detect power in the collision enforcement band and send the SQE message on Circuit CI using the CS0 signal. Send the SQE message for as long as energy is detected in the collision enforcement band.
- (9) Ensure that during collisions, due to phase cancellations of the colliding carriers, Circuit DI does not become inactive before Circuit CI becomes active.
- (10) Test the collision detection circuitry following every transmission that does not encounter a collision. This test consists of transmitting a burst of collision enforcement RF signal after the end of the postamble transmission and detecting this burst on the receive side. If the burst is detected, the CS0 (BR) signal is sent on Circuit CI of the transmitting MAU.

11.2.1.3.1 Collision Enforcement Transmitter Requirements. The MAU shall provide a collision enforcement (CE) transmitter that generates a constant amplitude RF signal in the CE band at the same power level as the data signal postamble.

11.2.1.2.2 Collision Enforcement Detection Requirements. The MAU shall detect energy in the CE band that is within the specified range of receive levels, irrespective of the signal power level in the data band.

11.2.1.4 Jabber Function Requirements. The MAU shall have a jabber function that inhibits transmission onto the coaxial cable interface if the MAU attempts to transmit an RF signal longer than 150 ms. The MAU shall provide an MTBF of at least 1 million hours of continuous operation without rendering the transmission medium unusable by other transceivers. Transmissions of less than 20 ms shall not be affected. When the jabber circuit is activated, *signal_quality_error* shall be sent on Circuit CI.

Circuit DO shall also be monitored for transmissions in excess of the maximum packet length. If the packet is longer than 20 ms, an attempt shall be made to deactivate the transmitter before the jabber circuit is activated, to avoid locking up the unit due to a non-MAU failure.

State diagrams defining the jabber function may be found in 11.2.3.

11.2.2 DTE PLS to MAU and MAU to DTE PLS Messages

11.2.2.1 DTE Physical Layer to MAU Physical Layer Messages. The following messages can be sent by the DTE Physical Layer Entities to the MAU Physical Layer Entities (refer to 7.3 of this standard for the definitions of the signals):

Message	Circuit	Signal	Meaning
<i>output</i>	DO	CD1, CD0	Output information
<i>output_idle</i>	DO	IDL	No data to be output

11.2.2.2 MAU Physical Layer to DTE Physical Layer Messages. The following messages can be sent by the MAU Physical Layer Entities to the DTE Physical Layer Entities:

Message	Circuit	Signal	Meaning
<i>input</i>	DI	CD1, CD0	Input information
<i>input_idle</i>	DI	IDL	No input information
<i>mau_available</i>	CI	IDL	MAU is available for output
<i>signal_quality_error</i>	CI	CS0 (BR)	Error detected by MAU

11.2.2.2.1 *input* Message. The MAU Physical Layer sends an *input* message to the DTE Physical Layer when the MAU has a bit of data to send to the DTE. The physical realization of the *input* message is a CD0 or CD1 sent by the MAU to the DTE on Circuit DI. The MAU sends CD0 if the input bit is a zero or CD1 if the input bit is a one. The jitter and asymmetry on CD0 and CD1 shall be no more than that specified in 7.5.2.1.

11.2.2.2.2 *input_idle* Message. The MAU Physical Layer sends an *input_idle* message to the DTE Physical Layer when the MAU does not have data to send to the DTE. The physical realization of the *input_idle* message is the IDL signal sent by the MAU to the DTE on Circuit DI.

11.2.2.2.3 *mau_available* Message. The MAU Physical Layer sends a *mau_available* message to the DTE Physical Layer when the MAU is available for output. The *mau_available* message is always sent by an MAU that is prepared to output data. The physical realization of the *mau_available* message is an IDL signal sent by the MAU to the DTE on Circuit CI.

11.2.2.2.4 *signal_quality_error* Message. The *signal_quality_error* message shall be implemented in the following fashion:

- (1) The *signal_quality_error* (SQE) message shall not be sent by the MAU if no or only one MAU is transmitting a legal length packet (as specified in this standard) on the coaxial medium, except as a part of the SQE self test.
- (2) If the MAU connected to the local node is not transmitting, then the local MAU shall send the *signal_quality_error* message in every instance when it detects power in the collision enforcement band earlier than the time equivalent for reception of a 512 bit data frame plus preamble and SFD.
- (3) When the local MAU is transmitting on the coaxial medium, all occurrences of one or more additional MAUs transmitting shall cause the *signal_quality_error* message to be sent by the local MAU to the attached DTE.
- (4) When the MAU has completed a successful transmission of a packet it shall perform an SQE Test sequence. In this instance, the collision enforcement RF signal is interpreted as an SQE Test signal.

11.2.3 MAU State Diagrams. The operation of the MAU during normal transmission and reception can be described by a state diagram that relates the functions of transmission, reception, collision detection, and collision detection testing. Figure 11-4, at the end of this subsection, shows the state transitions for normal operation. Abnormal conditions are implementation-specific.

The state diagram in Fig 11-4 does not describe the operation of the MAU in detail. This is found in 11.2 and 11.3.

The operation of the jabber function is described by the state diagram of Fig 11-5. When the MAU Jabber state machine is in the INTERRUPT or JAB state, outputs of the MAU Jabber state machine shall override those of the MAU state machine.

11.2.3.1 MAU State Diagram Messages. The following messages are used in the state diagram:

- (1) *disable_data_driver*. Deactivates the mechanism by which the RF data signal is impressed onto the coaxial cable.
- (2) *enable_data_driver*. Activates the mechanism by which the RF data signal is impressed onto the coaxial cable.
- (3) *disable_CE_driver*. Deactivates the mechanism by which collision enforcement RF signals are impressed onto the coaxial cable.
- (4) *enable_CE_driver*. Activates the mechanism by which collision enforcement RF signals are impressed onto the coaxial cable.
- (5) *mau_available*. Signifies that the MAU is available for transmission (that is, there is no SQE active).
- (6) *signal_quality_error* (SQE). Signifies that the MAU has detected a collision, it has successfully completed the SQE Test sequence, or the jabber circuit is active.
- (7) *start_SQE_test_timer*. Causes a timer to begin counting so that the SQE Test signal may be sent to the coaxial cable interface.
- (8) *positive_disable*. Prevents any RF signal from being sent onto the coaxial cable.

11.2.3.2 MAU State Diagram Signal Names. The signal names used in the state diagram are as follows:

- (1) *PowerOn*. This signal signifies that power has been applied to the unit.
- (2) *rx_energy*. When this signal is active, an RF signal on the coaxial cable has been detected either in the data band or in the collision enforcement band or in both. The delay in asserting or deasserting this signal is sufficiently short that the delays specified in 11.3.4.5 are met.
- (3) *output*. Signifies that data from the DTE is being presented for transmission at the AUI.
- (4) *tx_umd* (Transmit Unscrambled Mode Delimiter). When the Unscrambled Mode Delimiter has been detected in the transmit data sequence, this signal is asserted.
- (5) *rx_umd* (Receive Unscrambled Mode Delimiter). When the Unscrambled Mode Delimiter has been detected in the receive data sequence as it is conveyed from the coaxial cable interface, this signal is asserted.
- (6) *SQE_test_timer*. This signal is on during the time that the SQE Test Timer is engaged. At the end of the time, this signal is deasserted.
- (7) *rx* (Receive). As long as data is being presented by the MAU to Circuit DI of the AUI, this signal is active. When the last bit of the receive data has been presented to the AUI, this signal is deasserted.

- (8) ced (Collision Enforcement Detection). RF signal power in the collision enforcement band causes this signal to be asserted.
- (9) ced_window (Collision Enforcement Detection Window). This signal defines a period of time (a "window") during which collisions may occur. Its purpose is to distinguish collision enforcements from SQE Test sequences on the coaxial cable. The window opens when rx_energy goes active and closes a minimum of 365 bit times later. The maximum time the window may be open is the minimum frame length, plus preamble and SPD: 576 bits.
- (10) rx_umd_timeout (Receive Unscrambled Mode Delimiter Timeout). It is possible that the Receive Unscrambled Mode Delimiter may be corrupted by a collision such that the bit-by-bit comparison may not begin. This signal forces detection of a collision due to failure to detect the rx_umd within a maximum time. The timeout begins upon receipt of RF signal in the data band and expires 32 bit times later.
- (11) tx_ne_rx (Transmit Not Equal to Receive). Assertion of this signal occurs when a difference is detected between the received data stream and the transmitted data stream.
- (12) bbw (Bit-by-Bit Window). Bit-by-bit comparison shall be performed only for a time long enough to guarantee that the last bit of the source address has been examined. This signal is asserted after the UMD is received and throughout the bit-by-bit comparison process. To place a bound on the location of the source address relative to the UMD, the maximum preamble length permitted for operation with the broadband MAU is 62 bits. This places the last bit of the source address no later than 143 bits after the UMD.
- (13) ced_gate. This signal is a gating function that serves to shape the timing of ced during an SQE Test. It becomes true a minimum of 6 and a maximum of 16 bit times after the last bit has been presented to Circuit DI and stays active 10 ± 5 bit times.
- (14) tx_energy. This signal signifies that the MAU is attempting to transmit an RF signal onto the coaxial cable.
- (15) frame_timer. This signal is on from the beginning of output until it is reset or until it has been on continuously for timeout1 s. The value of timeout1 shall be greater than 20 ms and less than timeout2.
- (16) jab_timer. This signal turns on when tx energy turns on and lasts until it is reset or until it has been on continuously for timeout2 s. The value of timeout2 shall be greater than timeout1 and less than 150 ms.

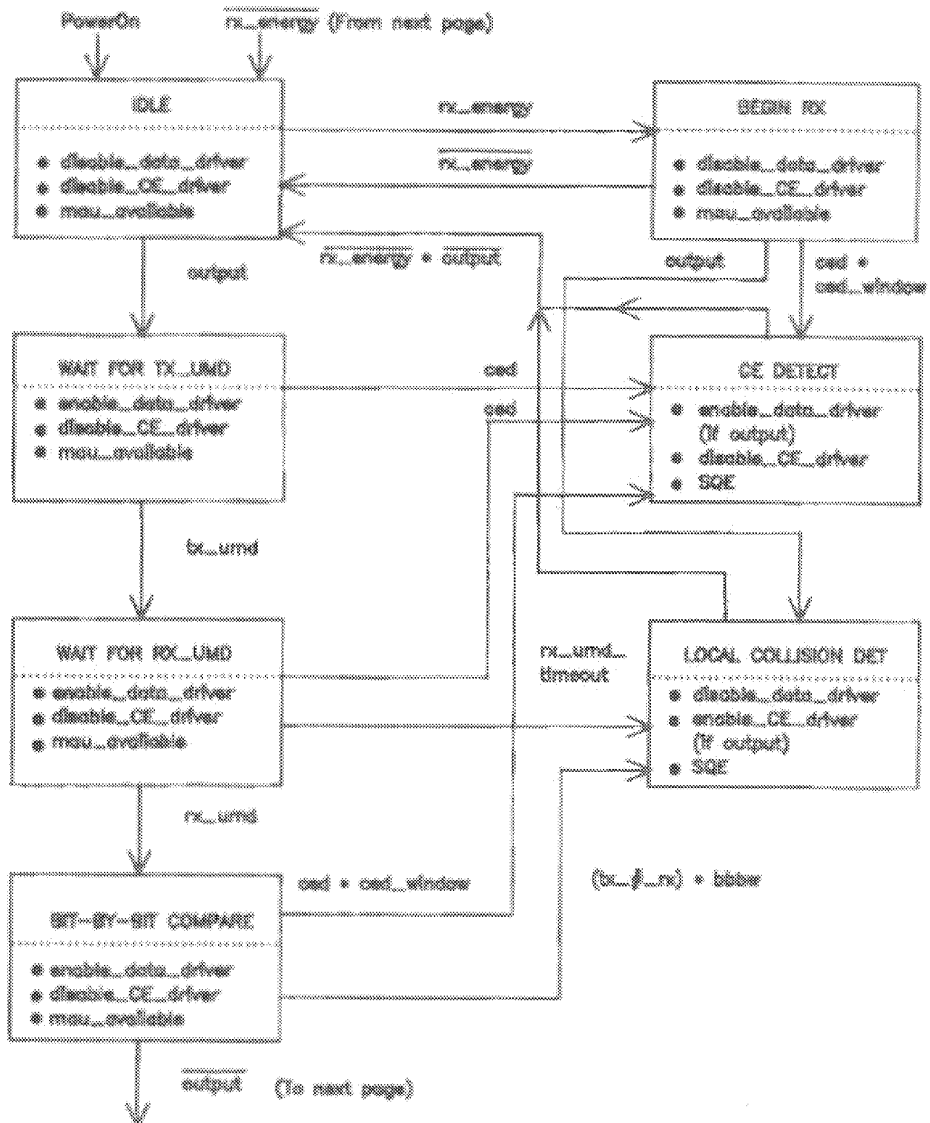

Fig 11-4
MAU State Diagram

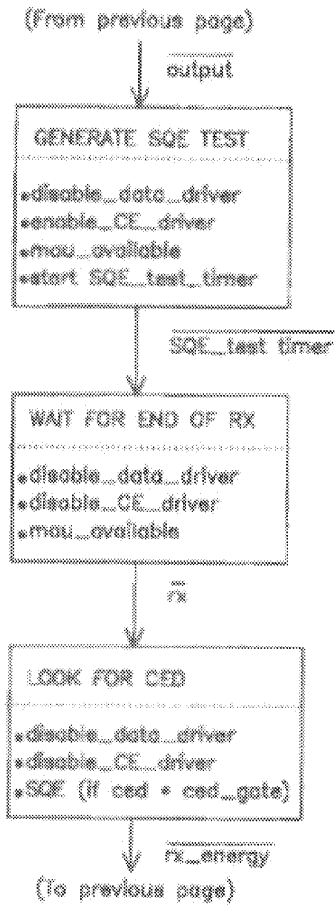

Fig 11-4
MAU State Diagram (continued)

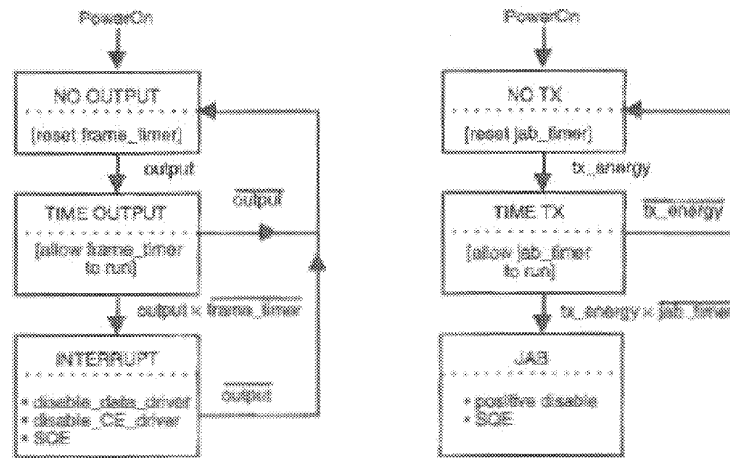

Fig 11-5
MAU Jabber State Diagram

11.3 MAU Characteristics

11.3.1 MAU-to-Coaxial Cable Interface. The following subsections describe the interface between the MAU and the broadband coaxial medium. The medium is a 75 Ω CATV-type broadband cable installation employing a single bidirectional cable with band-split amplifiers and filters, or dual unidirectional cables with line amplifiers.

11.3.1.1 Receive Interface

11.3.1.1.1 Receive Input Impedance. The nominal input impedance at the receive port shall be 75 Ω . The return loss within the data and collision enforcement frequency bands shall be at least 14 dB with power applied to the MAU.

11.3.1.1.2 Receiver Squelch Requirements. There shall be a receiver squelch that inhibits reception of RF signals that are too low in level. This squelch shall permit reception of RF data or collision enforcement signals that are greater than or equal to -7 dBmV rms as measured by the method of 11.3.1.2.5. RF signals (data, collision enforcement, noise, or other signals) of levels lower than -15 dBmV rms shall be ignored.

The receive squelch for CE signals shall be derived from a power detector with noise bandwidth greater than or equal to 1.5 MHz centered at the CE center frequency.

11.3.1.1.3 Receive Level Requirements. The receiver shall operate with RF data and CE signals having levels from -4 dBmV to +16 dBmV rms. The nominal receive level shall be +6 dBmV rms.

11.3.1.1.4 Receiver Selectivity and Linearity Requirements. The MAU shall operate in the presence of single frequency (CW) signals adjacent to the receive band of the MAU and offset from the band edges, received at the following levels:

- (1) 0 dBmV rms at 0.25 MHz below and above the band
- (2) 10 dBmV rms at 1.25 MHz below and above the band

The receiver shall be capable of operating in a cable environment loaded with TV signals (for example, every 6 MHz in the USA). The TV signals shall be no higher than +10 dBmV peak video at the receiver coaxial cable interface.

11.3.1.1.5 Receive Input Mechanical Requirements. The receiver mechanical interface shall be a 75 Ω female F-series coaxial connector. The connection to the broadband medium shall be through a coaxial drop cable with a mating male F-series connector. For single-cable configurations, the same connector may be used for receive and transmit.

11.3.1.2 Transmit Interface

11.3.1.2.1 Transmit Output Impedance. The nominal output impedance at the transmit port shall be 75 Ω . The return loss within the data and collision enforcement frequency bands shall be at least 14 dB with power applied.

11.3.1.2.2 Transmitted RF Packet Format. Figure 11-6 shows the transmitted RF packet format.

11.3.1.2.3 Transmit Spectrum and Group Delay Characteristics. The transmit RF data signal shall be binary phase-shift-keyed (PSK) modulated and shall have a frequency spectrum equivalent to baseband raised-cosine Nyquist filtering with a rolloff factor (α) of 0.4, and within the limits of Fig 11-7. For rectangular pulses, the filter characteristic is

$$H(j\omega) = \begin{cases} \frac{\omega T/2}{\sin(\omega T/2)} & \left[0 < \omega < \frac{\pi}{T}(1-\alpha) \right] \\ \frac{\omega T/2}{\sin(\omega T/2)} \cos^2 \left(\frac{T}{4\alpha} \left[\omega - \frac{\pi(1-\alpha)}{T} \right] \right); & \left[\frac{\pi}{T}(1-\alpha) < \omega < \frac{\pi}{T}(1+\alpha) \right] \\ 0; & \left[\omega > \frac{\pi}{T}(1+\alpha) \right] \end{cases}$$

where T = one symbol time (100 ns for 10 Mb/s) and $\alpha = 0.4$, and the first term accounts for the $\sin x/x$ spectrum of NRZ random data.

The total variation in group delay from Circuit DO to the RF coaxial medium interface shall not exceed 20 ns in the frequency band from the carrier frequency to ± 5 MHz, and 32 ns to ± 5.5 MHz.

The collision enforcement (CE) signal shall be a constant amplitude pulse with controlled turn-on and turn-off times. Random modulation may be added to reduce the probability of cancellation when more than one CE signal is received simultaneously. The modulated signal shall have an instantaneous frequency within 0.75 MHz of the CE band center frequency and shall conform to the spectrum mask specified in 11.3.1.2.4. The random modulation may be derived from the transmit NRZ data stream.

The CE signal rise and fall times shall approximate a Gaussian shape of the form:

$$f(t) = \exp\left(-\frac{1}{2}\left[\frac{t}{T}\right]^2\right)$$

where T = one symbol time and $t < 0$ for the rise time and $t > 0$ for the fall time.

The CE and data RF signals shall not be transmitted simultaneously.

11.3.1.2.4 Transmit Out-of-Band Spectrum. The transmitted power outside the specified band shall meet or exceed the relative attenuation (RA) specified below, under the following conditions:

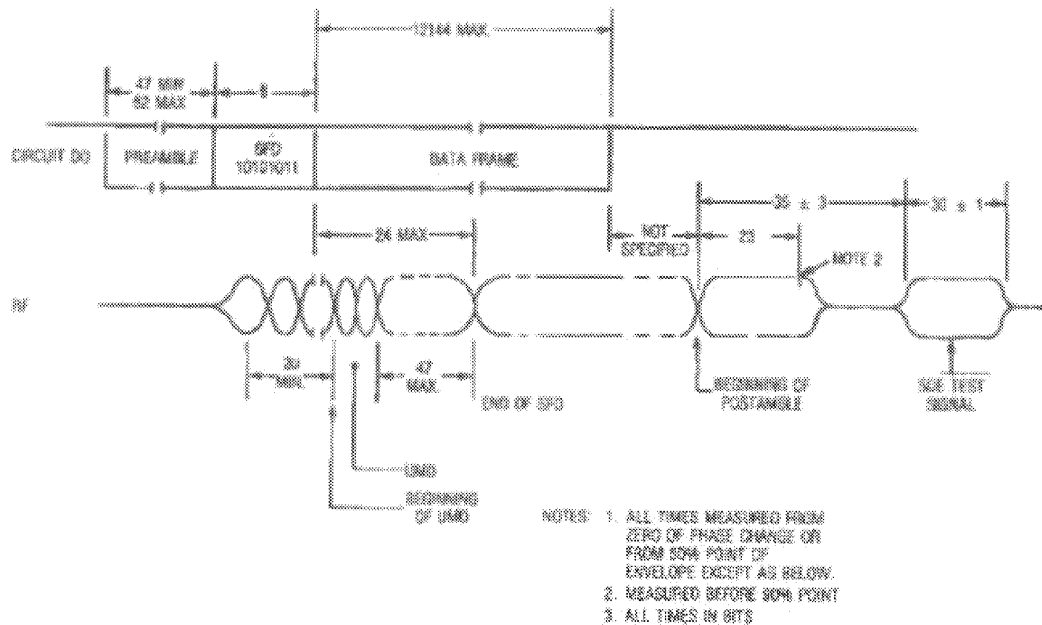

Fig 11-6
Packet Format and Timing Diagram (AUI to Coaxial Cable Interface)

- (1) Transmitted packet length is 256 bits with a 25.6 μ s interval between packets, for 50% duty cycle on the cable.
- (2) Reference level is an unmodulated carrier, equivalent to the postamble transmitted level.
- (3) RA is the attenuation in decibels relative to the reference level outside the specified band, measured in a 50 kHz noise bandwidth with a video filter of 300 Hz bandwidth or less.
- (4) B is 18 MHz, the width of data plus collision enforcement bands.
- (5) MF is the measurement frequency in MHz.
- (6) NCEF is the frequency of the nearest edge of the band, in MHz.

$$RA = \min \{ 63,55 + 30 \times [(MF - NCEF) / B] \}$$

Figure 11-8 graphically shows the attenuation requirement for out-of-band power.

11.3.1.2.5 Transmit Level Requirements. The transmitter output power during the postamble and during the SQE Test of the collision enforcement signal shall be 1000 mV peak-to-peak into a 75 Ω load (51 dBmV rms). Truncation loss due to the specified data filtering is 1 dB; transmitted RF data signal power is 50 dBmV rms. Transmit output power variations shall not exceed ± 2 dB.

11.3.1.2.6 Nontransmitting Signal Leakage Requirement. The RF data signal and collision enforcement signal leakage to the coaxial cable interface while the MAU is not in its transmission mode shall be less than -20 dBmV rms.

11.3.1.2.7 Transmit Spurious Output Requirement. All spurious signals from the transmitter (inband and out-of-band) while not transmitting shall be less than -20 dBmV rms. All spurious signals from the transmitter while transmitting data or collision enforcement shall be below the spectrum mask specified in 11.3.1.2.4.

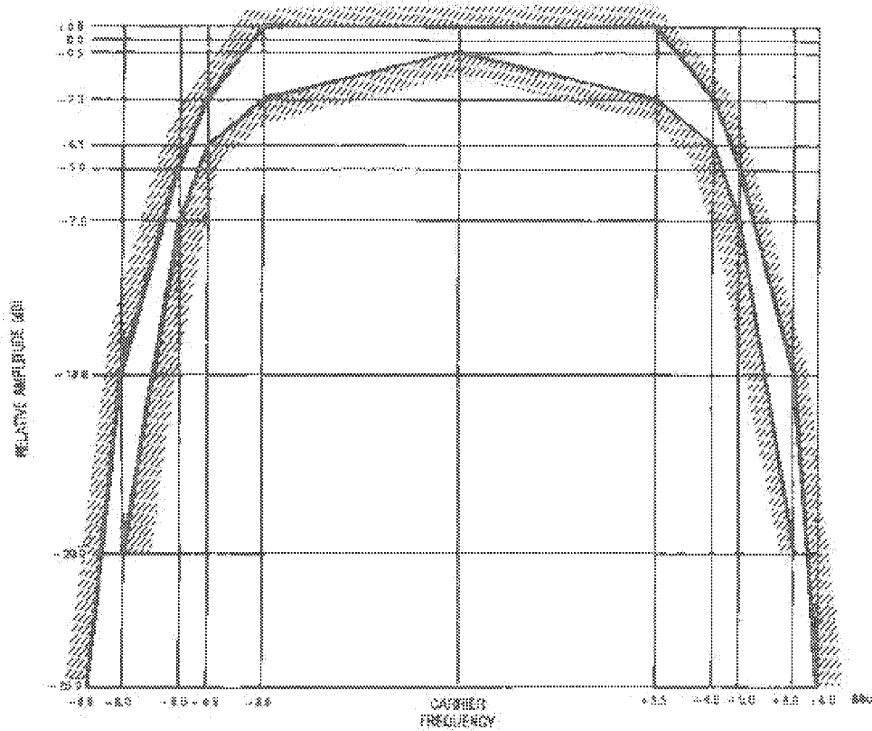

Fig 11-7
Spectrum Mask for RF Data Signal

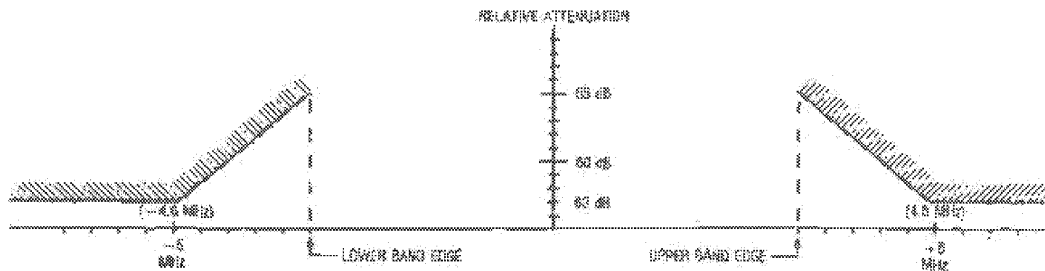

Fig 11-8
Transmit Out-of-Band Power Attenuation

11.3.1.2.8 Collision Enforcement Signal Leakage Requirement. The collision enforcement RF signal leakage to the coaxial cable during data transmission and while the MAU is not enforcing collisions shall be less than 5 dBmV rms. Leakage shall be less than -20 dBmV rms when the MAU is not in the transmission mode.

11.3.1.2.9 Transmit Output Mechanical Requirements. The transmit mechanical interface shall be a 75 Ω female F-series coaxial connector. The connection to the broadband medium shall be through a

coaxial drop cable with a mating male F-series connector. For single cable installations, the same connector may be used for transmit and receive.

11.3.2 MAU Frequency Allocations. The broadband MAU uses a data band 14 MHz wide and an adjacent collision enforcement band 4 MHz wide. A single cable midsplit configuration with a frequency offset of 156.25 MHz or 192.25 MHz between forward and reverse channels is recommended. Other configurations, including dual-cable, where forward and reverse channels are on separate unidirectional cables, also are permitted.* The preferred pairing for the usual North American 6 MHz channels is specified in Table 11.2-1 and Table 11.2-2. The tables also specify the data carrier or collision enforcement center frequency for each band, and for single-cable systems, the frequency translation and the headend local oscillator frequency.

11.3.2.1 Single-Cable Systems Frequency Allocations.* Table 11.2-1 lists the permissible frequency band allocations for single-cable systems. The 192.25 MHz translation is recommended for all new designs. The 156.25 MHz translation is allowed for compatibility with some existing systems. The 156.25 MHz translation results in a reversal of the data and collision enforcement bands, as the lower sideband is used.

11.3.2.2 Dual-Cable Systems Frequency Allocations.* In nontranslated dual-cable systems transmit and receive frequencies are identical. Table 11.2-2 lists the permissible frequency band allocations. In some instances translated dual-cable systems are installed. In such cases the single-cable frequency allocations may be used.

**Table 11.2-1
Single-Cable Frequency Allocations (Frequencies in MHz)**

TRANSMITTER			RECEIVER			
Data Carrier	Coll Enf Center Freq	Transmit Band	Translation 156.25 MHz		Translation 192.25 MHz	
			Headend Local Osc	Receive Band	Headend Local Osc	Receive Band
48	62	35.75-53.75	245.75	163-210	192.25	229-246
49	59	41.75-59.75	257.75	198-216	192.25	234-252
55	64	47.75-65.75	269.75	204-222	192.25	240-258
+61	70	53.75-71.75	281.75	210-228	192.25	246-264
67	76	59.75-77.75	293.75	216-234	192.25	252-270
73	82	65.75-83.75	305.75	222-240	192.25	258-276

NOTES: (1) Some of these optional bands are overlapping.
(2) Frequency tolerance of the data carrier and headend local oscillator shall each be ± 25 kHz.
(3) + denotes the preferred frequency allocation.

11.3.3 AUI Electrical Characteristics

11.3.3.1 Electrical Isolation Requirements. The MAU must provide isolation between the AUI cable and the broadband coaxial medium. The isolation impedance shall be greater than 250 k Ω at 60 Hz, measured between any conductor (including shield) of the AUI Interface cable and either the center conductor or shield of the coaxial cable. The isolation means provided shall be able to withstand 500 Vac rms for one minute.

The MAU power supply, if provided, shall meet the appropriate national requirements. See Reference [8] for guidance.

*The remainder of 11.3.2 and all of 11.3.2.1 and 11.3.2.2 are not part of the ISO standard. Frequency allocations are a subject for national standardization.

Table 11.3-2
Dual-Cable Frequency Allocations (Frequencies in MHz)

Data Carrier	Coll. Enf. Center Freq	Data Band	Coll. Enf. Band
43	53	35-50	50-54
49	58	42-66	50-60
65	64	48-62	62-66
+61	70	64-68	68-72
67	76	60-74	74-78
73	82	66-80	80-84
235.25	244.25	228-242	242-246
241.25	260.25	234-248	248-252
247.25	256.25	240-254	254-258
253.25	262.25	246-260	260-264
259.25	268.25	252-266	266-270
265.25	274.25	258-272	272-276

NOTES: (1) Some of these optional bands are overlapping.
(2) Frequency tolerance of the data carrier shall be ± 20 kHz.
(3) + denotes the preferred frequency allocations.

11.3.3.2 Current Consumption. The MAU may have its own power supply but is also allowed to use the power supplied by the DTE through the AUI cable. When drawing current from the AUI, the current shall not exceed 3.5 A as provided by the AUI source. The MAU shall be capable of operating from all possible voltage sources as supplied by the DTE through the resistance of all permissible AUI cables. The MAU shall not disrupt the broadband coaxial medium should the DTE power source fall below the minimum operational level under abnormal MAU load conditions. The MAU shall be labeled externally to identify the nominal value of current required by the device at the AUI.

11.3.3.3 Driver and Receiver Requirements. The requirements for AUI cable driver and receiver components within the MAU are identical with those specified in Section 7 of this standard. The drivers shall provide signals that meet the symmetry and jitter requirements of Circuit DI defined in Section 7 and the receivers shall accept signals that have traversed the worst-case lengths of AUI cable.

11.3.3.4 AUI Mechanical Connection. The MAU shall be provided with a 15-pin male connector as specified in detail in the PLS/AUI specifications, in 7.6 of this standard.

11.3.4 MAU Transfer Characteristics. Signals presented on Circuit DO are transformed into signals at the coaxial cable interface by delaying them and by reformatting them. Signals at the coaxial cable interface are transformed into signals on Circuit DI and Circuit CI by a different framing change and by additional delay.

11.3.4.1 AUI to Coaxial Cable Framing Characteristics. Data presented on Circuit DO shall first be received differentially, then Manchester decoded into an NRZ data stream. The framing of the data shall then be transformed into a new packet for presentation to the RF modulator in the following way (see Fig 11-6 and Fig 11-9):

- (1) Up to 5 bits of the incoming data stream may be dropped for detection and Manchester decoding purposes.
- (2) Beginning with the first zero, 20 bits of zero-one pattern shall be sent for receiver synchronization and clock recovery.

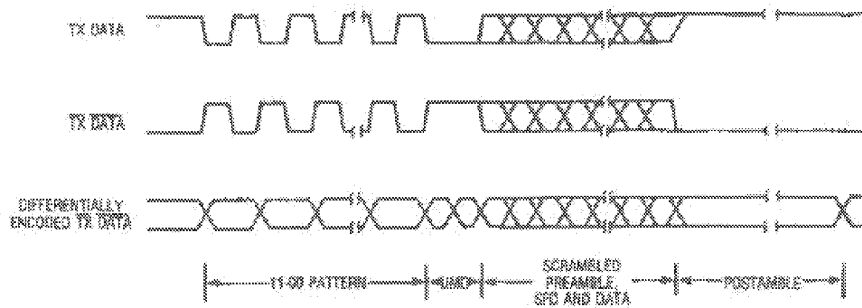

Fig 11-9
Packet Format at Modulator Input

- (3) The next two bits (zero-one in the incoming pattern) shall both be set to zero and form the Unscrambled Mode Delimiter (UMD). The UMD shall take the place of the zero-one in the incoming pattern; it shall not be inserted into the data stream.
- (4) All remaining bits in the preamble, SFD, and data fields shall be scrambled (using a CCITT V.29 scrambler plus a differential encoder per 11.3.4.1).
- (5) A postamble (BEOF) consisting of a zero followed by 22 ones shall be added immediately after the last scrambled data bit (the postamble is not scrambled). The postamble may be extended to allow controlled turnoff of the transmitted signal, as shown in Fig 11-6.
- (6) All bits (unmodified preamble; UMD; scrambled preamble, SFD, and data; and postamble) are inverted.
- (7) All bits sent to the RF modulator are differentially encoded. Figure 11-9 shows the appearance of the data before and after the differential encoder.
- (8) The SQE Test sequence shall be generated after a successful data transmission by transmitting a collision enforcement RF signal with the timing shown in Fig 11-6.

Because the preamble of the incoming data on Circuit DO is modified, it is assumed that DTEs generate a minimum length preamble of 47 bits. The maximum preamble length is allowed to be 62 bits, as shown in Fig 11-6.

11.3.4.1.1 Scrambler and Differential Encoding Requirements. The NRZ data shall be scrambled (using a CCITT V.29-type scrambler). A new seed shall be used by the scrambler for every new packet presented by the DTE to the MAU. Figure 11-10 is a diagram of a typical scrambler implementation.

The scrambled NRZ data shall be differentially encoded (see Fig 11-11 for a typical implementation).

The entire encoding process comprising the scrambling and differential encoding is essentially equivalent to a division of the polynomial representing the data to be transmitted by the following polynomial:

$$G(x) = 1 + x^1 + x^{16} + x^{19} + x^{25} + x^{26}$$

11.3.4.2 Coaxial Cable to AUI Framing Characteristics. The MAU shall demodulate, differentially decode, and invert the received RF data signal to recover the scrambled and inverted data stream. Clock shall be recovered and a replica of the unfiltered and noninverted transmitted data stream shall be created. The restored data shall be forced to a logic "one" state whenever no RF data signal is detected. This prevents false UMD detection and forces postamble detection when no carrier is present.

The framing information contained in the RF data stream shall be used to reconstruct the received data so that no more than 6 bits are lost and no more than one bit added to the preamble field, and no bits are added to or lost from the end of the transmit data. Detection of the UMD in the receive data shall initiate, after a fixed delay, a locally generated preamble sequence of zero-one pattern. This pattern "fills in" the preamble bits altered due to the framing information at the beginning of the packet: the zero-one synchronization and clock recovery sequence, the UMD, and the descrambler synchronization sequence.

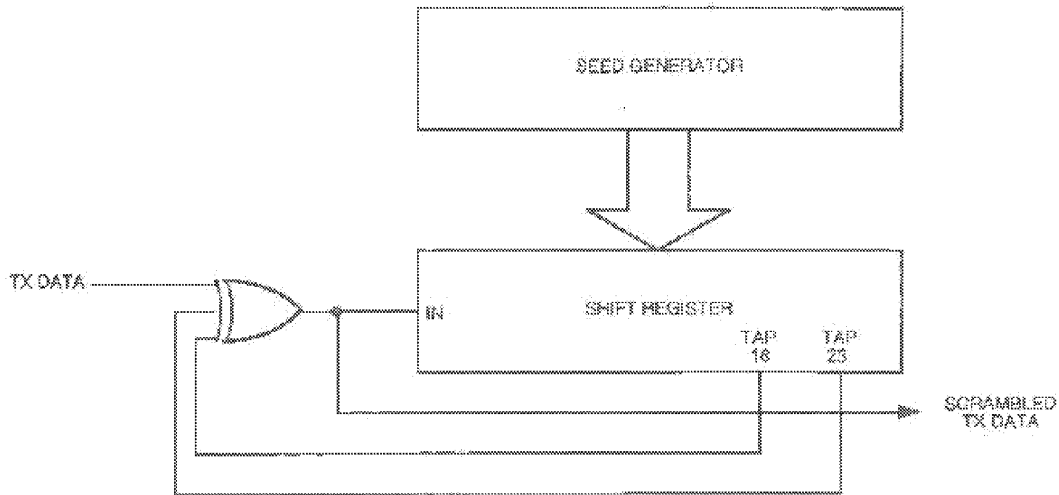

Fig 11-10
Scrambler

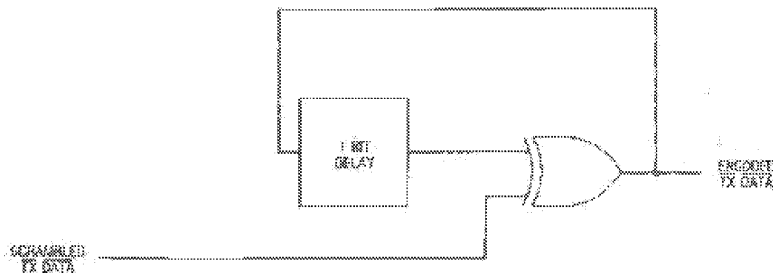

Fig 11-11
Differential Encoder

The MAU shall descramble the received data using a self-synchronizing (CCITT V.29-type) descrambler. No prior knowledge of the seed used by the scrambler shall be assumed by the descrambler circuit. The descrambler shall have valid output no later than 23 bit intervals after the UMD is detected by the receiver. An example of a descrambler is shown in Fig 11-12. The differential decoding performed by the demodulator and the descrambling function are essentially equivalent to multiplying the received polynomial by $Q(x)$ as defined in the scrambling and differential encoding requirements subsection above.

After the descrambler is synchronized, 23 bits after the UMD, the correctly descrambled receive data, starting with the 24th bit after the UMD, shall be transferred to the Manchester encoder and therefrom to the AUI. The delay from the detection of the UMD to the beginning of the locally generated zero-one pattern shall be chosen so that no more than 6 bits of preamble are lost, and no more than one bit added, in transmission from Circuit DO to Circuit DI.

The MAU shall detect the "zero" followed by 22 "ones" (the postamble pattern) and, in conjunction with the loss of carrier detection in the data band or the presence of a collision enforcement detection signal, shall ensure that the packet presented to the local DTE has no extraneous bits added by the MAU to the end of the packet.

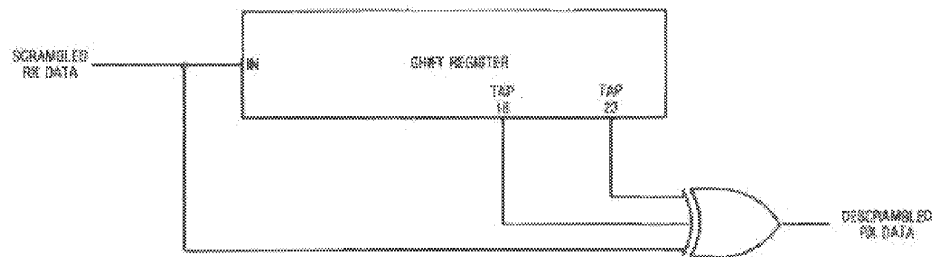

Fig 11-12
Descrambler

The SQE Test signal shall be detected on the RF interface and the SQE signal shall be presented to Circuit CI of the transmitting MAU, subject to the timing restrictions of 11.3.4.5.4. If the signal is not observed at the RF interface due to failure of any element in the transmitter or receiver, no SQE signal may be presented to the AUI. In the event of a collision enforcement, energy will appear in the collision enforcement band within the *ced_window* time after energy first appears in the data band. Circuit CI shall be asserted when collision enforcement is first detected and shall continue to be active until after the RF signal on the RF port has subsided. Note that an SQE Test signal appended to a packet whose length is less than the *ced_window* time (less than the minimum allowed packet length) will be indistinguishable from a collision enforcement, except by the MAU transmitting. The transmitting MAU shall take this into account and shall not interpret energy in the collision enforcement band to be a collision when the length of the transmitted packet is less than the *ced_window* time and the SQE Test sequence has been transmitted. See the discussion in 11.4.2 for more information on *ced_window*.

11.3.4.3 Circuit DO to Circuit DI Framing Characteristics. In the absence of a collision, the packet format of the receive data at the AUI is identical to that of the transmit data, except that there may be one more preamble bit than was sent at the transmit port and up to 6 bits of the preamble lost. In the presence of a collision, the receive data is undefined, but shall still be properly Manchester encoded.

11.3.4.4 AUI to Coaxial Cable Delay Characteristics. The timing and delays associated with the transmitter of the MAU are identified below. To ensure compatibility with all MAUs the delays identified below cannot be exceeded nor traded off with other delays in the system.

11.3.4.4.1 Circuit DO to RF Data Signal Delay. The delay from a transition on Circuit DO at the end of a bit to the corresponding phase change of the RF data signal (such bit chosen so that an RF burst phase change does exist) shall be no more than 24 bit times. The delay from the first transition on Circuit DO to the first appearance of RF energy, however, is not specified except as it is determined by other timing constraints.

11.3.4.4.2 Circuit DO to CE RF Output Delay. In the event that the MAU begins receiving energy on the coaxial medium just before the DTE presents data to the AUI, a collision shall be detected locally, as described in Fig 11-4. The delay from the first bit at Circuit DO of the AUI to the presentation of collision enforcement at the coaxial cable interface in this circumstance shall be 32 bit times maximum.

11.3.4.4.3 Transmit Postamble to SQE Test Signal Delay. The delay from the initial transition of the first bit of the postamble (Broadband End of Frame Delimiter) measured at the RF port to the 50% point of the rising edge of the SQE Test signal shall be 35 ± 3 bit times.

11.3.4.4.4 SQE Test Signal Length. The SQE Test signal length shall be 30 ± 1 bit times as measured at the 50% points of the RF signal.

11.3.4.5 Coaxial Cable to AUI Delay Characteristics. The MAU receiver timing and delays described below shall not be exceeded or traded off against any other delays in the system.

11.3.4.5.1 Received RF to Circuit DI Delay. When there is no collision in progress, the delay from the end of the SFD in the received RF data signal at the coaxial cable interface to the end of the SFD on Circuit DI, shall be a maximum of 75 bit times (see Fig 11-13). The minimum is not specified, nor is the delay specified at other locations in the packet. The end of the SFD in the received RF data signal (at the coaxial cable interface) is defined as the time at which the envelope of the carrier would pass through the midpoint if the first bit following the SFD was a zero and the scrambler disabled.

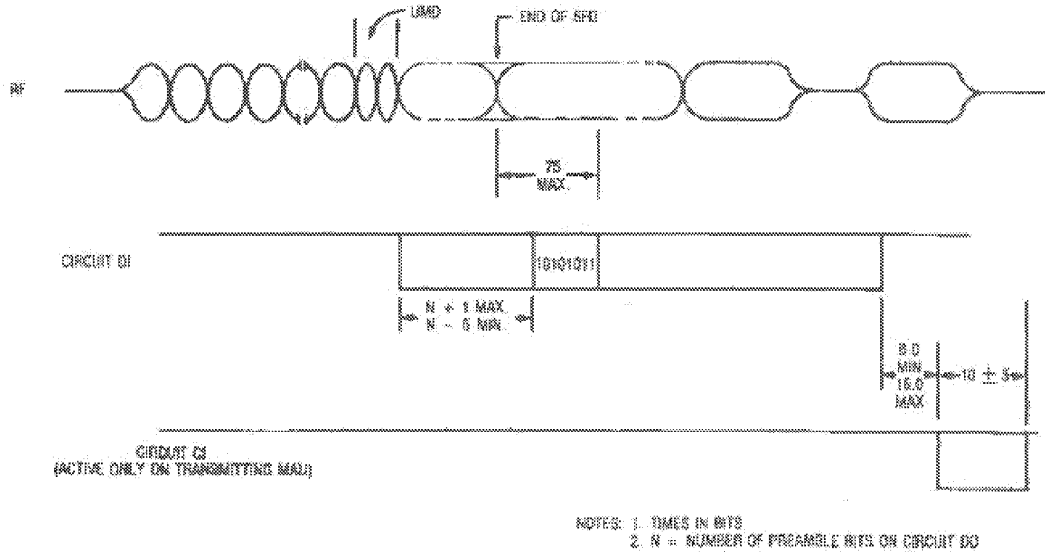

Fig 11-13
No Collision Timing Diagram (Coax to AUI)

11.3.4.5.2 Received RF to CE RF Output and Circuit CI Delay. In the event that a collision is detected via the bit-by-bit comparison, the delay from the end of the bit in which the collision was detected, as represented by the RF signal, to the 50% point on the rising edge of the collision enforcement signal shall not exceed 34 bit times. The delay from the same point to the first transition of Circuit CI shall not exceed 27 bit times. Circuit CI shall cease activity no more than 31 bit times after activity on the RF interface (in both data channel and collision enforcement channel) ceases. See Fig 11-14 and Fig 11-15.

11.3.4.5.3 Collision Enforcement to Circuit CI Delay. In the event of a collision enforcement by another MAU, the delay from the 50% point on the rising edge of the RF collision enforcement signal to the first transition of Circuit CI shall be no more than 31 bit times. Circuit CI shall be active for a minimum of 5 bit times and shall become inactive within 31 bit times of the cessation of activity on the RF coaxial cable interface, as shown in Fig 11-15.

11.3.4.5.4 Receive Data to SQE Test Delay. If a collision enforcement signal is received after the ced_window signal becomes inactive (see (9) in 11.2.3.2), or if the MAU has transmitted an SQE Test sequence, the MAU is to interpret the collision enforcement signal as an SQE Test signal. If the SQE Test sequence is correctly detected (that is, the test passes), then the delay from the last transition of Circuit DI to the first transition of Circuit CI shall be at least 6 but not more than 16 bit times. Circuit CI shall remain active for 10 ± 5 bit times. Only the transmitting MAU shall assert its Circuit CI as a result of successful completion of the SQE Test sequence.

If a collision enforcement signal is received before the ced_window signal becomes inactive, the MAU shall interpret it as a collision enforcement and the timing of 11.3.4.5.2 shall apply.

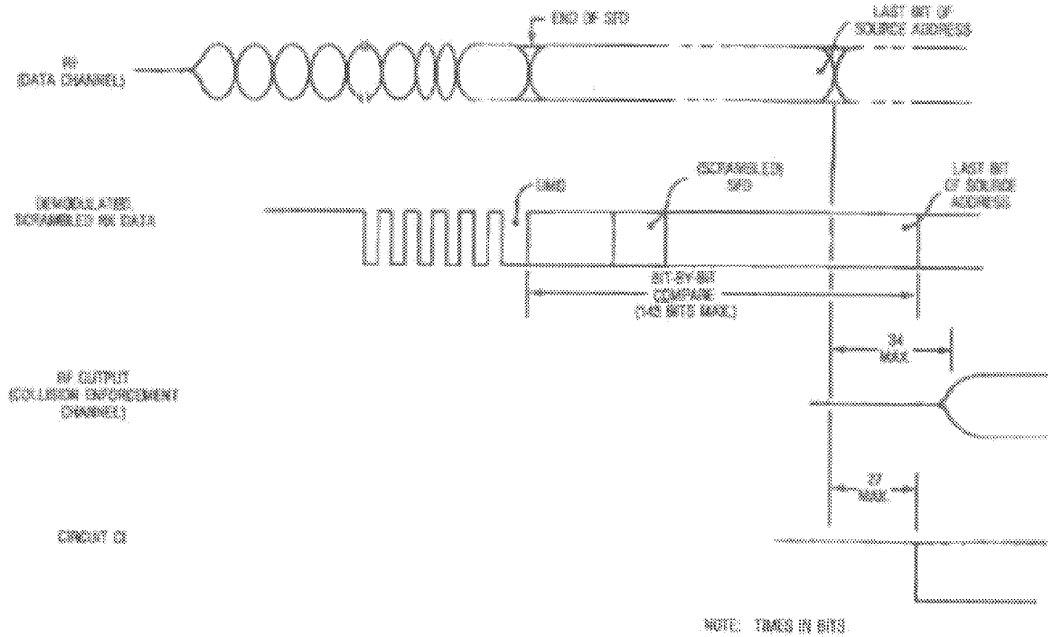

Fig 11-14
 Collision Timing Diagram (RF Data to RF Collision Enforcement)

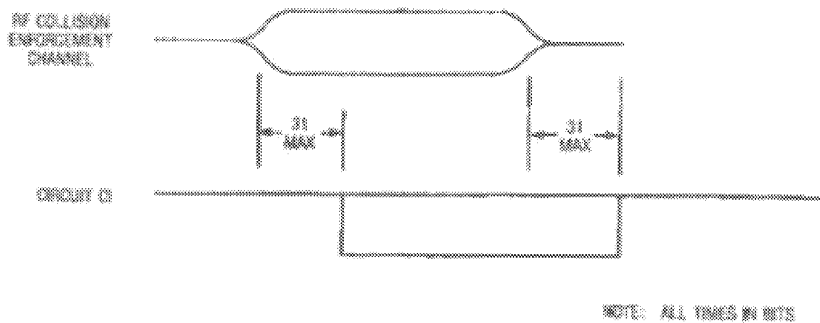

Fig 11-15
 Collision Timing Diagram (Coaxial Cable Interface to AUI Circuit CI)

11.3.4.6 Delay from Circuit DO to Circuit DI. The time delay from a bit on Circuit DO at the AU Interface to the corresponding bit on Circuit DI at the AU Interface is equal to the round trip delay of the MAU connected back-to-back with itself (that is, in RF loopback) plus the round trip delay through the cable system at the location of the MAU. Therefore, the delay is a function of the location of the MAU on the cable system. It is never less than the transmitter delay plus the postamble length plus the time to detect loss of carrier or presence of the SQE Test signal. See Fig 11-16 for the timing relationship when the cable has zero length.

When the MAU is transmitting a short packet (less than 576 bits), the timing for Circuit CI during the SQE Test sequence shall be the same as it is for normal length packets. If the MAU transmits a short packet (less than 576 bits) that encounters a collision and if the SQE Test sequence has not been

transmitted when the collision is detected by the MAU, then the timing for Circuit CI shall be the same as it is for any normal collision.

11.3.4.7 Interpacket Gap Requirement. The MAU shall be able and ready to transmit data presented to it by the DTE no later than 90 bit times after the last bit of a received packet was presented by the MAU at its AUI.

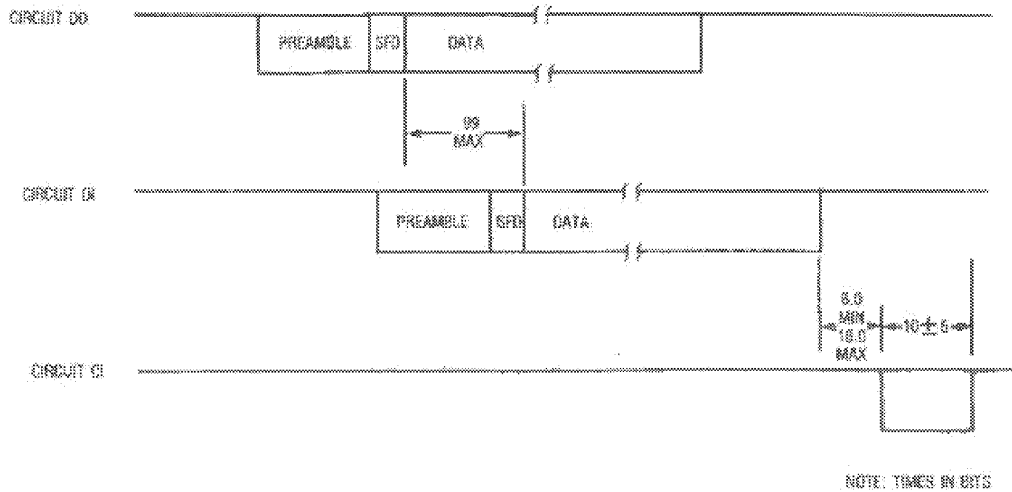

Fig 11-16
Timing at AUI for Zero-Length Coax

11.3.4.8 Bit Error Rate. The MAU shall have a Bit Error Rate (BER) as measured at the AUI lower than one error in 10^8 in a "zero-length coax" test environment (that is, a coaxial cable connection sufficiently short to have negligible delay and transmission impairments). It shall have this BER for receive signal levels in the range specified in 11.3.1.1.3 and in the presence of -28.3 dBmV rms/14 MHz white Gaussian noise. This represents a 24.3 dB signal-to-noise ratio for the specified minimum signal level, -4 dBmV rms. For the same BER in a "system" environment (as opposed to zero-length coax), a 26 dB signal-to-noise ratio is required.

The MAU shall meet the BER requirements specified above when receiving strings of up to 33 consecutive identical bits.

11.3.5 Reliability. Component failures within the MAU electronics should not impede communication among other MAUs on the broadband coaxial cable. Connectors and other passive components comprising the means of connecting the MAU to the coaxial cable shall be designed to minimize the probability of total network failure. The MAU shall be designed to provide an MTBF of at least 1 000 000 hours without causing communication failure among other stations attached to the broadband local network medium.

11.4 System Considerations

11.4.1 Delay Budget and Network Diameter. The delay budget for the broadband MAU and rest of the Physical Layer is tabulated in Table 11.4-1. This table includes allocations for trunk cables (the backbone cables in the system), drop cables (a length of 25 m is assumed), etc. The velocities of propagation assumed are included in the table; use of other types of cables will alter the system diameter accordingly. The types of cables, including the mix of drop and trunk cable lengths, can be altered as long as the total

propagation delay from the most distant MAU to the headend does not exceed 70 bit times. The total delay budget of 576 bit times includes allowance for the preamble and SFD (64 bits).

Table 11.4-1 tabulates delay allocations for a dual-cable system with no headend delay. In translated single-cable systems, the headend translator delay reduces the maximum trunk cable distance by $[D/(3 \times CV)]$, where D is the delay in nanoseconds, and CV is the cable velocity in nanoseconds per meter. For 3.83 ns/m velocity trunk cable, this reduction is $[Delay (ns) / 7.66] m$.

**Table 11.4-1
Broadband Dual-Cable Systems—Physical Layer Delay Budget**

Delay Element	Maximum Allowed Value (Bits)
DTE1 starts to put out first bit	0.00
First bit from DTE1 at AUI	3.00
AUI Cable (50 m at 5.13 ns/m)	2.57
Circuit DO to Tx RF Out	34.00
Tx Drop Cable (25 m at 4.27 ns/m)	1.05
Tx Trunk Cable (1800 m at 3.83 ns/m)	68.95
Rx Trunk Cable (25 m at 4.27 ns/m)	68.95
Rx Drop Cable (25 m at 4.27 ns/m)	1.05
End of Bit Comparisons (last bit of source address)	100.00
Rx RF to Collision Enforcement RF Out (from RX bit that is found to be in error to collision enforcement out)	34.00
Tx Drop Cable (25 m at 4.27 ns/m)	1.05
Tx Trunk Cable (1800 m at 3.83 ns/m)	68.95
Rx Trunk Cable (1800 m at 3.83 ns/m)	68.95
Rx Drop Cable (25 m at 4.27 ns/m)	1.05
Rx Collision Enforcement to Circuit CI	31.00
AUI Cable (50 m at 5.13 ns/m)	2.57
DTE1 Detects Collision Presence	3.00
DTE1 Jams Channel	52.00
Allowance for Traps, Splitters, Amplifiers, and Margin	3.56
Total	576.00

11.4.2 MAU Operation with Packets Shorter than 512 Bits. The MAU transmits an SQE Test sequence onto the RP medium after every transmitted packet. If the frame plus preamble and SFD is less than the `ced_window` in length, a receiving MAU cannot distinguish the SQE Test signal from a collision enforcement signal due to a collision. Therefore, operation of the MAU with data frames shorter than 512 bits may cause all other receiving MAUs to see a collision. The transmitting MAU, however, recognizes the SQE Test because that MAU was the one that transmitted the test. An MAU transmitting a short packet that encounters a collision can distinguish the resulting collision enforcement from an SQE Test signal by the fact that the transmitting MAU will not have transmitted the SQE Test sequence unless the packet is shorter than the round trip delay on the cable plant. In the latter instance, the transmitting MAU may not detect a collision enforcement.

11.5 Characteristics of the Coaxial Cable System. The cable system upon which the broadband MAU operates shall meet the following electrical and mechanical requirements.

11.5.1 Electrical Requirements. The electrical requirements of the cable system are listed in Table 11.5-1. Each parameter is applicable over the frequency range to be used by the broadband MAU.

Adjacent channel signal levels shall be consistent with the requirements of 11.3.1.1.4.

Table 11.5-1
Cable System Electrical Requirements

Impedance	75 Ω
Return Loss	14 dB min
Transmit Level	+0 dBmV \pm 2 dB
Receive Level	+6 dBmV \pm 10 dB
Maximum Receive Noise Level	-30 dBmV/14 MHz
Loss Variation* (per 18 MHz band)	2 dB min, 52 dB max
Path Loss (between any transmit port and receive port, including loss variation)	34 dB min, 53 dB max
Group Delay Variation	
—around data carrier	20 ns/10 MHz max
—over 18 MHz band	34 ns max

* Not including headend.

11.5.2 Mechanical Requirements. The connection of the cable system to the broadband MAU is via a standard F-series screw-on male connector. For the dual-cable case, two such connectors are required: one for transmit and the other for receive.

11.5.3 Delay Requirements. The maximum length of the cable system is constrained by the allowable round trip delay from the farthest transmitting MAU to the farthest receiving MAU. Table 11.4-1 allows 140 bit times round trip delay in the cable system. For trunk cable propagation velocity of 2.83 ns/m, this allows 3600 m of trunk cable (round trip; 1800 m from the farthest point to the headend), and 25 m of 4.27 ns/m velocity drop cable at each MAU. In addition, 50 m of AUI cable is allowed on each MAU, therefore allowing, in this case, a maximum of 3750 m DTE to DTE separation. These lengths will be different if cables of different propagation velocity are used. This is acceptable so long as the maximum delay is not exceeded.

For single-cable systems, the maximum delay of 140 bit times includes the delay through the headend. The maximum cable system length must be reduced appropriately, as described in 11.4.1.

11.6 Frequency Translator Requirements for the Single-Cable Version

11.6.1 Electrical Requirements. The headend frequency translator performance is included in the cable system characteristics specified in 11.5, except as defined in Table 11.6-1.

Table 11.6-1
Frequency Translator Requirements

Group Delay Variation	
—around data carrier frequency	20 ns/10 MHz max
—between data carrier and CE center frequency	50 ns max
Amplitude Variation (from 0 MHz below the input data carrier frequency to 1 MHz above the CE center frequency)	2 dB max
Translation Frequency	per Table 11.3-1

The frequency translator contributes to total cable system delay and shall be labeled by the vendor with the input-to-output delay in the band of operation. The effect on network length can then be computed per 11.4.1.

11.6.2 Mechanical Requirements. The input and output mechanical interface shall be 75 Ω female F-series coaxial connectors. The connection to the broadband medium shall be through a coaxial cable with a mating male F-series connector.

11.7 Environmental Specifications

11.7.1 Safety Requirements. This subsection sets forth a number of recommendations and guidelines related to safety concerns. This list is neither complete nor does it address all possible safety issues. The designer is urged to consult the relevant local, national, and international safety regulations to assure compliance with the appropriate standards.

Local area network cable systems, as described in this section, are subject to at least four direct electrical safety hazards during their use, and designers of connecting equipment should be aware of these hazards. The hazards are as follows:

- (1) Direct contact between local network components and power or lighting circuits
- (2) Static charge buildup on local network cables and components
- (3) High-energy transients coupled onto the local network cabling system
- (4) Potential differences between safety grounds to which various network components are connected

These electrical safety hazards, to which all similar cabling systems are subject, should be alleviated for a local network to perform properly. In addition to provisions for properly handling these faults in an operational system, special measures shall be taken to ensure that the intended safety features are not negated when attaching or detaching equipment from the local area network medium of an existing network.

Sound installation practice, as defined in applicable national and local codes and regulations, shall be followed in every instance in which such practice is applicable.

11.7.2 Electromagnetic Environment

11.7.2.1 Susceptibility Levels. Sources of interference from the environment include electromagnetic fields, electrostatic discharge, transient voltages between earth connections, etc.

The physical MAU hardware shall meet its specifications when operating in an ambient plane wave field of:

- (1) 2 V/m from 10 kHz through 30 MHz
- (2) 5 V/m from 30 MHz through 1 GHz

MAUs meeting this section should provide adequate RF ground return to satisfy the EMC specification.

11.7.2.2 Emission Levels. The physical MAU hardware shall comply with the applicable national and local regulations for emission levels.

11.7.3 Temperature and Humidity. The MAU and associated cable system are expected to operate over a reasonable range of environmental conditions related to temperature, humidity, and physical handling such as shock and vibration. Specific requirements and values for these parameters are considered to be beyond the scope of this standard.

12. Physical Signaling, Medium Attachment, and Baseband Medium Specifications, Type 1BASE5

12.1 Introduction

12.1.1 Overview. 1BASE5 is a 1 Mb/s CSMA/CD network based on twisted pair wiring. Each DTE (Data Terminal Equipment) is star-connected to a shared hub through two pairs that function as transmit and receive channels. Hubs can be cascaded, and DTEs can be connected to any hub. Packets transmitted by a DTE are propagated by the hub to a higher-level hub if one exists; otherwise the hub broadcasts the packet back down to all DTEs and lower-level hubs. Packets received by a hub from a higher-level hub are retransmitted to all attached DTEs and lower-level hubs. If two or more DTEs or lower-level hubs transmit concurrently, the hub generates a collision-presence signal that the DTEs detect as a collision. Hubs between a transmitting DTE and the header (highest level) hub propagate data or the collision-presence signal to the header hub; this hub in turn broadcasts the packet or collision signal to all DTEs and lower-level hubs.

12.1.2 Scope. The 1BASE5 specification builds upon the first six major sections of this standard; the remaining major sections (other than this one, of course) do not apply to 1BASE5. That is, the Media Access Control (MAC) and Physical Signaling (PLS) Service Specifications are used in common with the other implementations of this standard, but the Physical Medium Attachment (PMA) sublayer, transmission medium, and hub functions for Type 1BASE5 are specified in this section. The relationship of the 1BASE5 specification to the OSI Reference Model and the IEEE 802.3 CSMA/CD LAN Model is shown in Fig 12-1.

12.1.3 Definitions

bit cell. The time interval used for the transmission of a single data (CD0 or CD1) or control (CVH or CVL) symbol.

bit rate (BR). The rate of data throughput on the medium (in b/s or Hz, whichever is more appropriate to the context). See 12.3.2.4.1.

bit time (BT). The duration (of transmission) of one bit symbol (bit cell) (1/BR). See 12.3.2.4.1.

carrier sense. In a local area network, an ongoing activity of a data station to detect whether another station is transmitting. Note that the signal provided by the PLS to the PMA sublayer indicates that one or more DTEs are currently transmitting.

Clocked Data One (CD1). A Manchester encoded data "1." A CD1 is encoded as a LO for the first half of the bit cell and a HI for the second half of the bit cell.

Clocked Data Zero (CD0). A Manchester encoded data "0." A CD0 is encoded as a HI for the first half of the bit cell and a LO for the second half of the bit cell.

Clocked Violation HI (CVH). A symbol that deliberately violates Manchester encoding rules, used as part of the Collision Presence signal. A CVH is encoded as a transition from LO to HI at the beginning of the bit cell, HI for the entire bit cell, and a transition from HI to LO at the end of the bit cell.

Clocked Violation LO (CVL). A symbol that deliberately violates Manchester encoding rules, used as part of the Collision Presence signal. A CVL is encoded as a transition from HI to LO at the beginning of the bit cell, LO for the entire bit cell, and a transition from LO to HI at the end of the bit cell.

collision. A condition that results from concurrent transmissions on the physical medium.

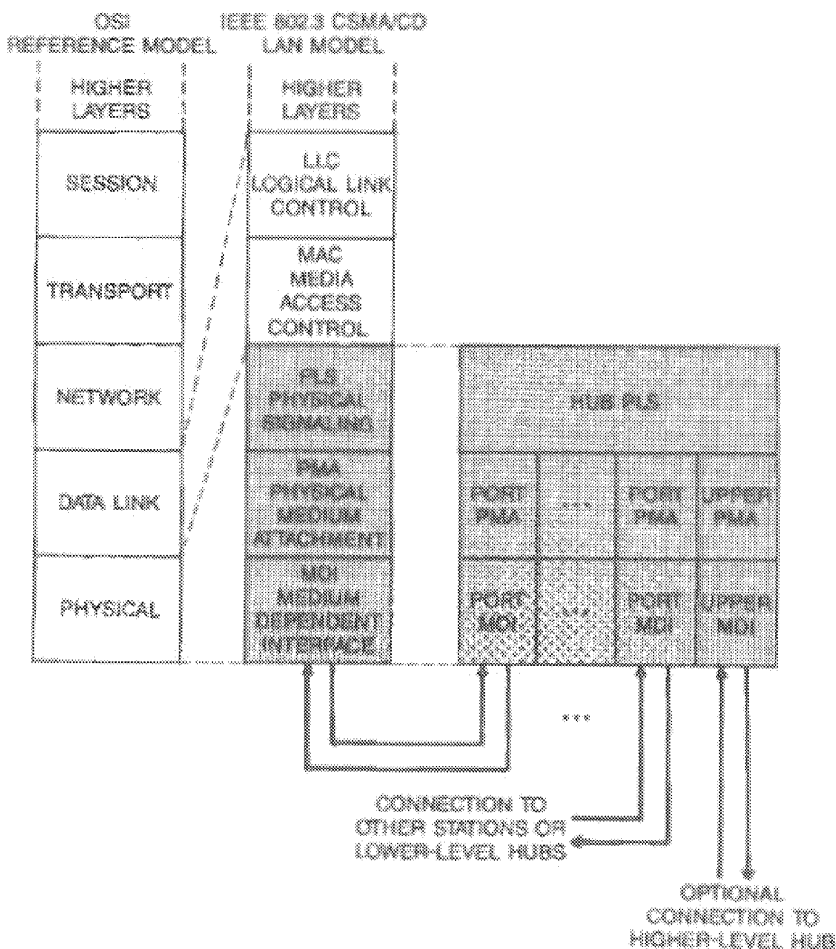

Fig 12-1
IBASE5 Relationship to the ISO Open Systems Interconnection (OSI)
Reference Model and the IEEE 802.3 CSMA/CD LAN Model

Collision Presence (CP). The non-Manchester signal generated by hubs to report collisions and some error conditions. See 12.3.2.4.3 for details.

header hub (HH). The highest-level hub in a hierarchy of hubs. The HH broadcasts signals transmitted to it by lower-level hubs or DTEs, such that they can be received by all DTEs that may be connected to it, either directly or through intermediate hubs. See 12.2.1 for details.

hub. A device used to provide connectivity between DTEs. Hubs perform the basic functions of restoring signal amplitude and timing, collision detection and notification, and signal broadcast to lower-level hubs and DTEs.

idle (IDL). A signal condition where no transition occurs on the transmission line. It is used to define the time between packets. See 12.3.2.4.4 for details.

intermediate hub (IH). A hub that occupies any level below the header hub in a hierarchy of hubs. See 12.2.1 for details.

Jabber Function. A mechanism for controlling abnormally long transmissions.

special link (SL). A transmission system that replaces the normal medium. See 12.8 for details.

12.1.4 General Characteristics. Type 1BASE5 has the following general characteristics:

- (1) 1 Mb/s signaling rate, Manchester encoded
- (2) Twisted pair wiring
- (3) Point-to-point interconnection of DTEs to hubs, with one twisted pair serving as the upward link, the other as the downward link
- (4) Data pairs can coexist in the same telephone cable bundles as voice pairs
- (5) When a hub receives signals from a DTE or lower-level hub, it propagates them to a higher-level hub if one exists; otherwise, the hub broadcasts the signals back down to the DTEs and lower-level hubs
- (6) When a hub receives signals concurrently from two or more DTEs or lower-level hubs, it generates a unique collision presence signal, and distributes it as in (5) above
- (7) DTE-to-hub and hub-to-hub interfaces are electrically isolated at both ends
- (8) Up to five hub levels are allowed
- (9) Hubs serve as repeaters
- (10) Maximum DTE-to-hub and hub-to-hub distance is approximately 250 m for telephone wiring (cable-type dependent; see 12.7)
- (11) Special links may be used to extend some DTE-to-hub or hub-to-hub distances to 4 km

12.1.5 Compatibility. This specification calls out one principal compatibility interface, namely PMA-to-Medium. It is intended that different implementations of DTEs and hubs be able to interoperate in 1BASE5 networks.

12.1.6 Objectives of Type 1BASE5 Specification

- (1) Provide for low-cost networks, as related to both equipment and cabling
- (2) Make it possible to use telephone-type building wiring, and in particular spare wiring when available
- (3) Provide for easy installability, reconfigurability, and service
- (4) Ensure interconnectability of independently developed DTEs and hubs
- (5) Ensure fairness of DTE access
- (6) Provide a communication channel with a resultant mean bit error rate, at the physical layer service interface, of less than one part in 10^8 (on the order of one part in 10^9 at the link level)

12.2 Architecture

12.2.1 Major Concepts. Type 1BASE5 is a 1 Mb/s CSMA/CD network. DTEs are connected to hubs (and hubs to other hubs) by point-to-point wiring, resulting in a star topology network. Data transmissions are Manchester encoded.

An elementary configuration is illustrated in Fig 12-2. In this instance, each DTE is connected to the hub via separate transmit and receive channels (normally two twisted pairs). The hub serves as the point of concentration and performs two major functions: signal regeneration/retiming (repeating) and collision detection. When only one DTE transmits, the hub repeats the signals, compensating for amplitude and phase distortion, and broadcasts to all DTEs. When a hub detects two or more DTEs transmitting concurrently, the hub generates a unique Collision Presence (CP) signal, which it broadcasts instead of the originally transmitted signals. The hub continues to send CP until it receives IDI from all lower-level DTEs. CP has the property that it can be detected by DTEs as a Manchester code violation.

The interconnection architecture does not imply any minimum, typical, or maximum number of DTEs to be connected to a given hub; this is an implementation or installation detail.

Up to five levels of hubs may be cascaded. A two-level configuration is illustrated in Fig 12-3, with a head-or hub (HH) and intermediate hubs (IH). There can be a number of IHs; there must be one and only one HH. Each DTE or IH is connected to a hub via separate transmit and receive channels (normally two twisted pairs). An IH propagates signals from its DTEs toward the HH; it sends CP toward the HH in the event of

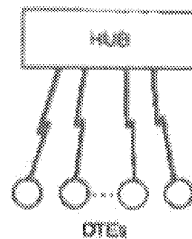

Fig 12-2
Single Hub Network

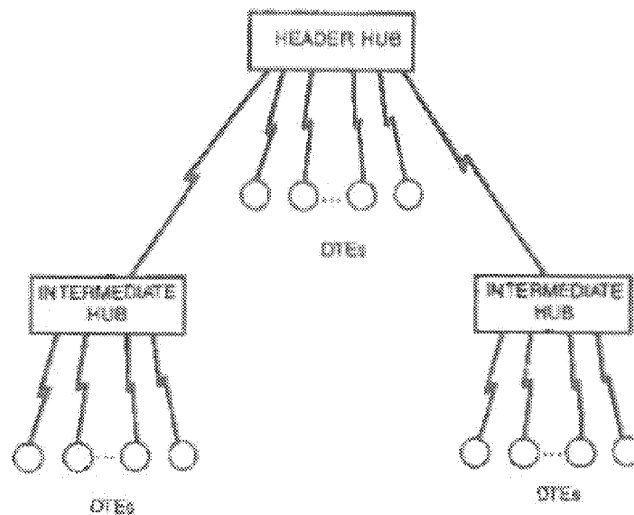

Fig 12-3
Network with Two Levels of Hubs

a collision. The HH repeats the signals it receives from DTEs or IHs back down to all DTEs and IHs. The HH generates CP if more than one of its inputs becomes active. The IHs repeat the signals received from the HH, and broadcast to all the connected DTEs' receivers. Hubs do not distinguish whether input signals along the upward path emanate from DTEs or lower-level IHs. If a single input is active, the hub repeats the signal regardless of its source; if more than one is active, it generates CP.

A configuration involving four hub levels and a special link is illustrated in Fig 12-4. In this example, one IH is used for simple repeating (one connection upward and one connection downward). Other than having one link in and one link out, repeaters are identical to other hubs. Special links are connections, possibly containing active devices, that are used for situations requiring extra propagation delay or special transmission media.

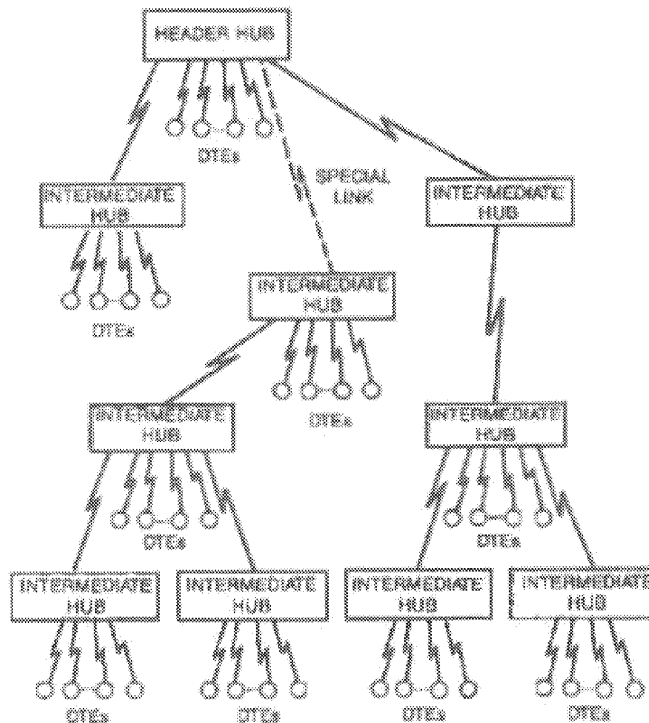

Fig 12-4
Network with Four Levels of Hubs

12.2.2 Application Perspective. The primary application area for type 1BASE5 is expected to be in office environments for networking DTEs such as personal computers or other workstations. In many cases, spare wiring contained in existing telephone wire bundles will be used.

12.2.3 Packet Structure. Packets are transmitted from the PLS to the PMA as follows:

<silence> <preamble> <afd> <data> <etd> <silence>

The packet elements shall have the following characteristics:

Element	Characteristics
<silence>	No transitions
<preamble>	Alternating CD1 and CD0 for 256 bit times (ending in CD0)
<afd>	CD1 CD0 CD1 CD0 CD1 CD0 CD1 CD1
<data>	8 × N instances of CD0 or CD1
<etd>	First part of IDL

12.2.3.1 Silence. The <silence> delimiter provides an observation window for an unspecified period of time during which no transitions occur. The minimum duration of <etd> followed by <silence> is the *interFrameSep* defined in 4.4.2.2.

12.2.3.2 Preamble. The <preamble> delimiter begins a packet transmission and provides a signal for receiver synchronization. The signal shall be an alternating pattern of CD1 and CD0. This pattern shall be transmitted by the DTE for a minimum of 56 bit times at the beginning of each packet. The last bit of the preamble (that is, the final bit of preamble before the start-of-frame delimiter) shall be a CD0.

The DTE is required to supply at least 56 bits of preamble in order to satisfy system requirements. System components consume preamble bits in order to perform their functions. The number of preamble bits sourced ensures an adequate number of bits are provided to each system component to correctly implement its function.

12.2.3.3 Start-of-Frame Delimiter. The <afd> indicates the start of a frame, and follows the preamble.

12.2.3.4 Data. The <data> in a transmission shall be in multiples of eight (8) encoded data bits (CD0s and CD1s).

12.2.3.5 End-of-Transmission Delimiter. The <etd> indicates the end of a transmission and serves to turn off the transmitter. The signal shall be the first part of an IDL.

12.3 DTE Physical Signaling (PLS) Specification

12.3.1 Overview. This section defines logical characteristics of the DTE PLS sublayer for IBASE5. The relationship of this specification to the entire standard is shown in Fig 12-5. The sublayer and its relationship to the MAC and PMA sublayers are described in an abstract way and do not imply any particular implementation.

12.3.1.1 Summary of Major Concepts

- (1) There are two channels between the PLS and PMA sublayers. Output data are passed through the output channel and input data and control (CP) are passed through the input channel.
- (2) Each direction of data transfer through the PLS operates independently and simultaneously (that is, the PLS is full duplex).

12.3.1.2 Application Perspective. The DTE PLS sublayer performs the following functions:

- (1) Encodes OUTPUT_UNITS from the MAC sublayer into a Manchester encoded waveform that it sends to the PMA sublayer output circuit
- (2) Decodes a Manchester encoded waveform from the PMA sublayer input circuit into INPUT_UNITS, CARRIER_STATUS, and SIGNAL_STATUS

12.3.2 Functional Specification. This section provides a detailed model for the DTE PLS sublayer. Many of the terms used in this section are specific to the interface between this sublayer and the MAC sublayer. These terms are defined in the service specification for the PLS sublayer (see 6.3).

12.3.2.1 PLS-PMA Interface. The PLS and PMA communicate by means of the following messages:

Message	Meaning	Source
<i>output</i>	Output information	PLS
<i>output_idle</i>	No data to be output	PLS
<i>input</i>	Input information	PMA
<i>input_idle</i>	No input information	PMA

12.3.2.1.1 output Message. The PLS sublayer sends an *output* message to the PMA sublayer when the PLS sublayer receives an OUTPUT_UNIT from the MAC sublayer.

The physical realization of the *output* message is a CD0 or a CD1 sent by the PLS to the PMA. The PLS sends a CD0 if the OUTPUT_UNIT is a ZERO or a CD1 if the OUTPUT_UNIT is a ONE. This message is time-coded. That is, once this message has been sent, the function is not completed until one bit time later.

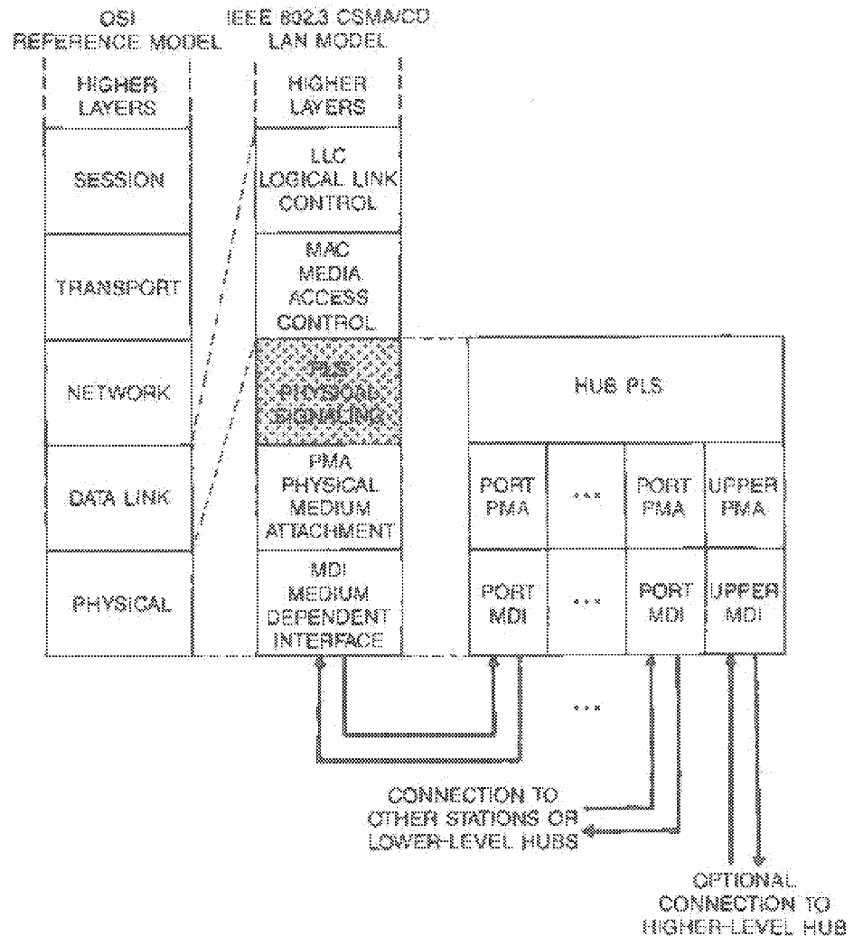

Fig 12-5
Station Physical Signaling, Relationship to the ISO OSI Reference Model
and the IEEE 802.3 CSMA/CD LAN Model

The *output* message cannot be sent again until the bit cell being sent as a result of sending the previous *output* message is complete.

12.3.2.1.2 *output_idle* Message. The PLS sublayer sends an *output_idle* message to the PMA sublayer at all times when the MAC sublayer is not in the process of transferring output data across the MAC to PLS interface. The *output_idle* message is no longer sent (and the first OUTPUT_UNIT is sent using the *output* message) when the first OUTPUT_UNIT of a packet is received from the MAC sublayer. The *output_idle* message is again sent to the PMA when DATA_COMPLETE is received from the MAC sublayer.

The physical realization of the *output_idle* message is IDL sent by the PLS to the PMA.

12.3.2.1.3 *input* Message. The PMA sublayer sends an *input* message to the PLS sublayer when the PMA has received a bit from the medium and is prepared to transfer this bit to the PLS.

The physical realization of the *input* message consists of data units, CDG, CD1, CVL, or CVH, derived from the incoming data stream. If ambiguity exists due to excessive noise or jitter, the PMA may send an arbitrary combination of these.

12.3.2.1.4 *input_idle* Message. The PMA sublayer sends an *input_idle* message to the PLS sublayer when the PMA sublayer does not have data to send to the PLS sublayer. This condition exists when carrier is lost or IDL is received.

12.3.2.2 PLS-MAC Interface. The PLS and MAC communicate by means of the following messages:

Message	Meaning	Source
OUTPUT_UNIT	Data sent to the PMA	MAC
OUTPUT_STATUS	Response to OUTPUT_UNIT	PLS
INPUT_UNIT	Data received from the PMA	PLS
CARRIER_STATUS	Indication of input activity	PLS
SIGNAL_STATUS	Indication of error/no error condition	PLS

12.3.2.2.1 OUTPUT_UNIT. The MAC sublayer sends the PLS sublayer an OUTPUT_UNIT every time the MAC sublayer has a bit to send. Once the MAC sublayer has sent an OUTPUT_UNIT to the PLS sublayer, it may not send another OUTPUT_UNIT until it has received an OUTPUT_STATUS message from the PLS sublayer. The OUTPUT_UNIT is a ONE if the MAC sublayer wants the PLS sublayer to send a CD1 to the PMA sublayer, a ZERO if a CD0 is desired, or a DATA_COMPLETE if an IDL is desired.

12.3.2.2.2 OUTPUT_STATUS. The PLS sublayer sends the MAC sublayer an OUTPUT_STATUS in response to every OUTPUT_UNIT received by the PLS sublayer. OUTPUT_STATUS sent is an OUTPUT_NEXT when the PLS sublayer is ready to accept the next OUTPUT_UNIT from the MAC sublayer. (The purpose of OUTPUT_STATUS is to synchronize the MAC sublayer data output with the data rate of the physical medium.)

12.3.2.2.3 INPUT_UNIT. The PLS sublayer sends the MAC sublayer an INPUT_UNIT every time the PLS receives an *input* message from the PMA sublayer. The INPUT_UNIT is a ONE if the PLS sublayer receives a CD1 from the PMA sublayer or a ZERO if the PLS sublayer receives a CD0 from the PMA sublayer. The INPUT_UNIT may be either ZERO or ONE if the PLS sublayer receives a CVL or CVH from the PMA sublayer.

12.3.2.2.4 CARRIER_STATUS. The PLS sublayer sends the MAC sublayer CARRIER_STATUS whenever there is a change in carrier status, as detected by the PMA. The PLS sublayer sends CARRIER_ON when it receives an *input* message from the PMA and the previous CARRIER_STATUS that the PLS sublayer sent to the MAC sublayer was CARRIER_OFF. The PLS sublayer sends CARRIER_OFF when it receives an *input_idle* message from the PMA sublayer, and the previous CARRIER_STATUS that the PLS sublayer sent to the MAC sublayer was CARRIER_ON.

12.3.2.2.5 SIGNAL_STATUS. The PLS sublayer sends the MAC sublayer SIGNAL_STATUS whenever it detects the beginning or end of Collision Presence. The PLS sublayer sends SIGNAL_ERROR when it receives *input* message CVL or CVH from the PMA sublayer and the previous SIGNAL_STATUS the PLS sublayer sent was NO_SIGNAL_ERROR. The PLS sublayer sends NO_SIGNAL_ERROR when it receives an *input_idle* message from the PMA sublayer and the previous SIGNAL_STATUS that the PLS sent to the MAC sublayer was SIGNAL_ERROR. The PLS shall send SIGNAL_ERROR to the MAC sublayer when the Collision Presence pattern is detected; it may send SIGNAL_ERROR any time it receives an *input* message that is neither CD0 nor CD1.

12.3.2.3 PLS Functions. The PLS sublayer functions consist of four simultaneous and asynchronous functions. These functions are Output, Input, Error Sense, and Carrier Sense. All of the four functions are started immediately following PowerOn. These functions are depicted in the state diagrams shown in Fig 12-8 through Fig 12-9, using the notation described in 1.2.1.

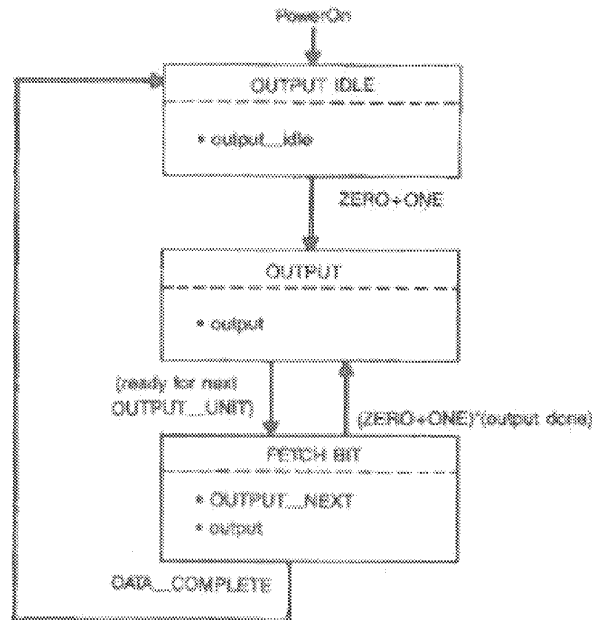

Fig 12-6
DTE PLS Output Function.

12.3.2.3.1 State Diagram Variables. The variables used in the state diagrams and the corresponding descriptions are the following:

(1) Inter Process Flags

disable_SIGNAL_ERROR	Used in the state diagrams and functions. It is used by the Input Function to prevent false collision detection by the Error Sense Function during preamble startup.
protectTimer	Used by the Carrier Sense Function to implement the protection period described in 12.5.3.2.3. It is started by "start-protectTimer." "protectTimer_done" is satisfied when the timer has expired.

12.3.2.3.2 Output Function. The Output Function transparently performs the task of data transfer from the MAC sublayer to the PMA sublayer. The state diagram of Fig 12-6 depicts the Output Function operation.

12.3.2.3.3 Input Function. The Input Function transparently performs the task of data transfer from the PMA sublayer to the MAC sublayer. The state diagram of Fig 12-7 depicts the Input Function operation.

12.3.2.3.4 Error Sense Function. The Error Sense Function performs the task of sending SIGNAL_STATUS to the MAC sublayer at the beginning and end of the Collision Presence pattern. The state diagram of Fig 12-8 depicts the Error Sense Function operation.

12.3.2.3.5 Carrier Sense Function. The Carrier Sense Function performs the task of sending CARRIER_STATUS to the MAC sublayer whenever the input becomes active or idle, as detected by the PMA sublayer. The state diagram of Fig 12-9 depicts the Carrier Sense Function operation.

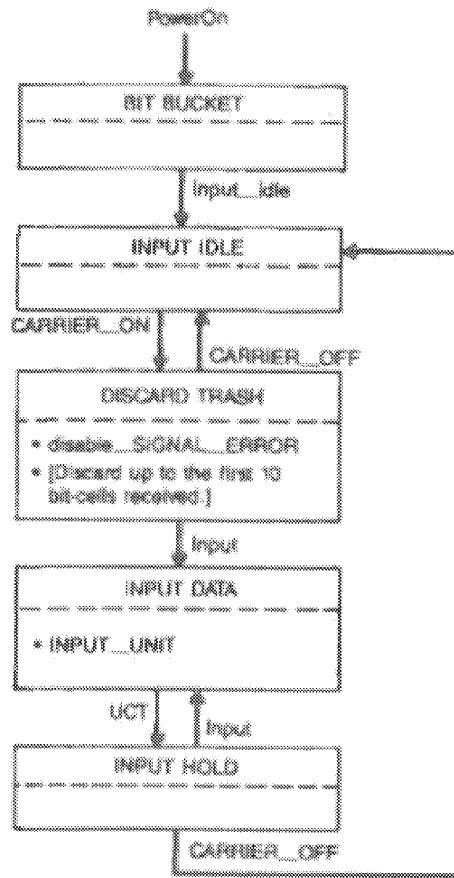

Fig 13-7
DTE PLS Input Function

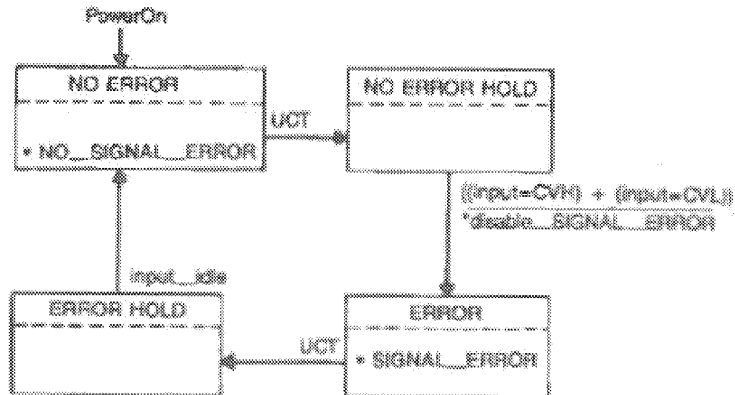

Fig 13-8
DTE PLS Error Sense Function

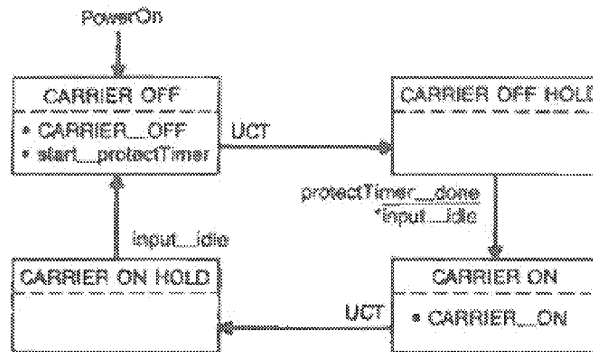

Fig 12-9
DTE PLS Carrier Sense Function

A timer may be used by the Carrier Sense Function to implement the protection period described in 12.5.3.2.3. It is started by "start-protectTimer" and asserts "protectTimer_done" after 0 to 30 μ s since starting.

12.3.2.4 Signal Encoding. Five distinct symbols can be transmitted on the line: CD0, CD1, CVL, CVH, and IDL. Of these, CVL and CVH are transmitted only as part of the collision presence reporting pattern CP.

12.3.2.4.1 Data Transmission Rate. The data transmission rate (BR) is 1 Mb/s \pm 0.01%. A bit time (BT) is therefore nominally 1 μ s.

12.3.2.4.2 Data Symbol Encoding. Manchester encoding is used for the transmission of packets. Manchester encoding is a binary signaling mechanism that combines data and clock into bit cells. Each bit cell is split into two halves with the second half containing the binary inverse of the first half, a transition always occurs in the middle of each bit cell. During the first half of the bit cell, the encoded signal is the logical complement of the bit value being encoded. During the second half of the bit cell, the encoded signal is the uncomplemented value of the bit being encoded. Thus, a CD0 is encoded as a bit cell in which the first half is HI and the second half is LO. A CD1 is encoded as a bit cell in which the first half is LO and the second half is HI. Examples of Manchester waveforms are shown in Fig 12-10. The zero crossings of an ideal Manchester waveform occur on precise half-bit-cell boundaries. The zero crossings of real waveforms may include timing jitter that causes deviation from these "idealized zero crossings."

12.3.2.4.3 Collision Presence Encoding. Two signals, CVL and CVH, that are transmitted only as part of the collision presence reporting pattern, CP, violate the normal Manchester encoding rule requiring a transition in the middle of each symbol. A CVH is encoded as a transition from LO to HI at the beginning of the bit cell, HI for the entire bit cell, and transition from HI to LO at the end of the bit cell. A CVL is encoded as a transition from HI to LO at the beginning of the bit cell, LO for the entire bit cell, and transition from LO to HI at the end of the bit cell.

The Collision Presence reporting signal, CP, is a special sequence that differs from any legitimate Manchester-encoded signal. CP is encoded as a repeating sequence of 1 bit time LO, 1/2 bit time HI, 1 bit time LO, 1 bit time HI, 1/2 bit time LO, and 1 bit time HI. This may also be interpreted as repetitions of the five-symbol sequence CVL, CD0, CD1, CVH. Should a transmitter's or receiver's timing be shifted by 1/2 bit time, then the same sequence will be interpretable as repetitions of CD1, CVL, CVH, CD1, CD0. In either case, the presence of non-Manchester symbols distinguishes the sequence from data. Examples of

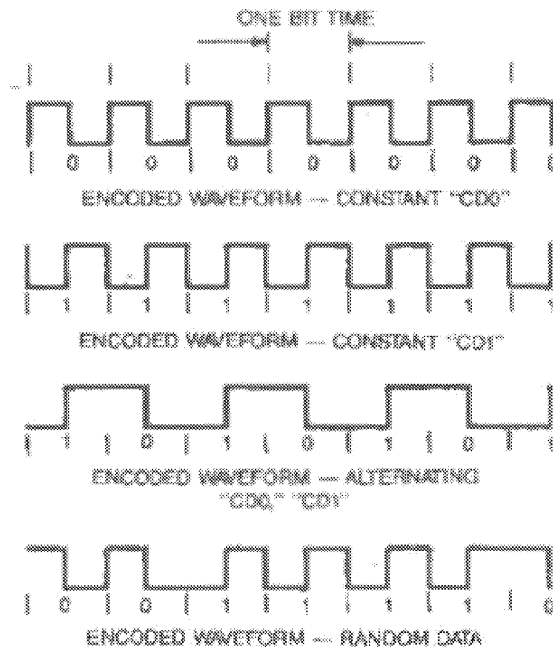

Fig 12-10
Examples of Manchester Waveforms

Collision Presence waveforms are shown in Fig 12-11. See 12.9.2.2.5 and 12.4.3.2 for further details on the detection and generation of CP.

NOTE: CP is the minimal length sequence that meets the following design criteria:

- (1) The sequence should not look like legitimate Manchester-encoded data even if the receiver does not lock onto the correct bit-cell boundaries.
- (2) The sequence should maintain overall dc balance. That is, it should be HI 50% of the time and LO the other 50%.
- (3) The signal should occupy the same part of the frequency spectrum as normal data. That is, transitions should occur every half or whole bit time so that the fundamental signaling frequencies of BR/2 and NR are maintained. Furthermore, allowing more than one bit time to pass without a transition would introduce ambiguity with the idle line condition (IDL).

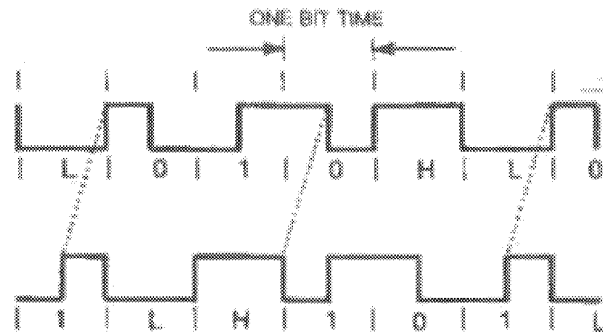

Fig 12-11
Examples of Collision Presence Waveforms

12.3.2.4.4 Idle Line Encoding. The line condition IDL is also used as an encoded signal. An IDL always starts with a HI signal level. Since IDL always starts with a HI signal, an additional transition will be added to the data stream if the last bit sent was a zero. This transition cannot be confused with clocked data (CD0 or CD1) since the transition will occur at the start of a bit cell. There will be no transition in the middle of the bit cell. The HI signal level, as sent by a transmitter, shall be maintained for a minimum of 2 bit times.

12.4 Hub Specification

12.4.1 Overview. This section defines the logical characteristics of the hub used in 1BASE5. The relationship of this specification to the entire standard is shown in Fig 12-12.

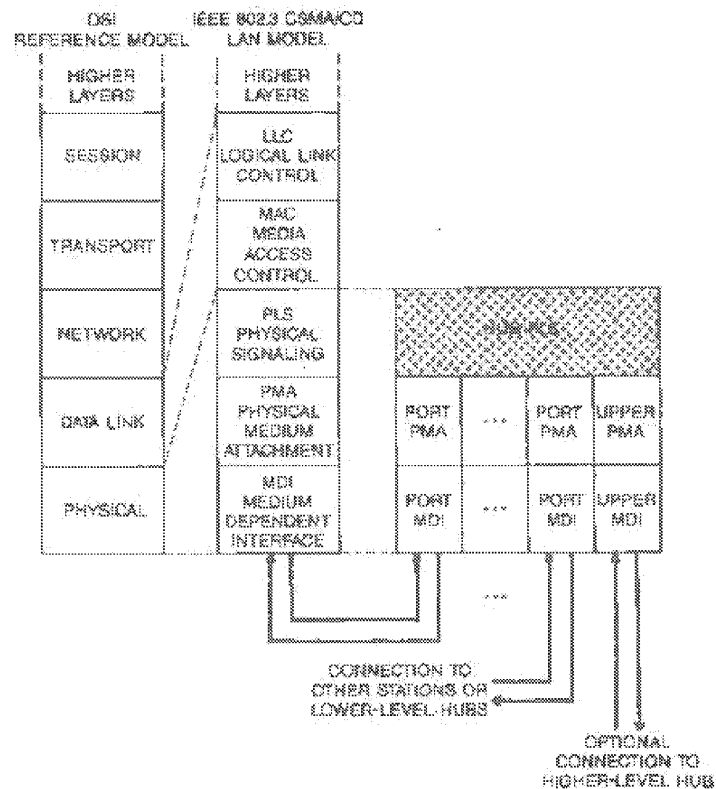

Fig 12-12
Hub Relationship to the OSI Reference Model
and the IEEE 802.3 CSMA/CD LAN Model

12.4.1.1 Summary of Major Concepts

- (1) A hub consists of a Hub PLS sublayer and a number of instances of the PMA sublayer.
- (2) One instance of the PMA sublayer, the "upper PMA," provides a connection to a higher-level hub. This PMA is not required for the header hub.
- (3) Each of the remaining instances of the PMA sublayer, called "port PMAs," provides a connection to a DTE or a lower-level hub.

- (4) The Hub PLS transfers data in two directions: upward from the port PMAs, to the upper PMA and downward from the upper PMA to the port PMAs.
- (5) The upward and downward "sides" of the hub operate independently and simultaneously.

12.4.1.2 Application Perspective. The hub is a physical layer entity that performs two functions:

- (1) It retransmits incoming signals with amplitude and timing restored.
- (2) It detects collisions between any two or more ports and reports knowledge of the collision by transmitting a special collision presence reporting pattern.

12.4.2 Hub Structure. Each hub is functionally divided into two parts: the upward side and the downward side. The upward side is responsible for combining the transmissions from DTEs and hubs lower in the network into a single transmission to the next level up. The downward side is responsible for distributing the combined signal (which is wrapped around from the upward side of the header hub) to each of the DTEs and hubs below. Except as specified in 12.4.3.2.3 and 12.4.2.6, the two sides function independently.

There is an upward input channel and a corresponding downward output channel for each DTE or hub immediately below the hub. Although there is no electrical connection between the two lines, they do share a connector and cable (see 12.6 and 12.7) and are collectively known as a hub port. Each port is accessed through an instance of the PMA sublayer referred to as a "port PMA."

The one output channel from the upward side and the one input channel to the downward side of a hub are similarly paired and, for all but the header hub, are connected to a port of the next-higher-level hub. They are accessed through an instance of the PMA sublayer referred to as the "upper PMA."

NOTE: A hub that includes *n* hub ports should be called an *n*-port hub, even though it may have an extra jack for the upper PMA. The latter connection should never be counted as a port, despite common engineering usage, because it does not meet the specific definition of a 10BASE5 hub port given above.

12.4.2.1 Upward Side. The primary function of the upward side of a hub is to propagate signals from each of its inputs to its single output. If more than one input is active, then the Collision Presence signal CP is transmitted instead. In addition, the signals are retimed to restore the transitions to half-bit-time boundaries; see 12.4.3.2.5 for the details of retiming.

12.4.2.2 Downward Side. The primary function of the downward side of a hub is to repeat signals from its one input to each of its outputs. In addition, the signals are retimed to restore the transitions to half-bit-time boundaries; see 12.4.3.2.5 for the details of retiming.

12.4.3 Hub PLS Functional Specification. This section provides a detailed model for the Hub PLS sublayer.

12.4.3.1 Hub PLS to PMA Interface. The interface between the Hub PLS and the PMA is the same as that specified in 12.3.2.1 for use between the DTE PLS and the PMA except that the *output* message from the Hub PLS to the PMA is used to transmit CVL and CVH in addition to CD0 and CD1.

12.4.3.2 Hub PLS Functions. The Hub PLS sublayer functions consist of three asynchronous functions. These functions are Upward Transfer, Jabber, and Downward Transfer. All three functions are started immediately following PowerOn; an independent copy of the Jabber function is started for each port PMA. These functions are depicted in the state diagrams shown in Fig 12-13 through Fig 12-15, using the notation described in 1.2.1.

12.4.3.2.1 State Diagram Variables. The variables used in the state diagrams and the corresponding descriptions are the following:

- (1) *Port Designators:* Instances of the PMA sublayer are referred to by index. PMA information is obtained by replacing the X in the desired function with the index of the PMA of interest. Furthermore, PMAs may be referenced by several special designators used as indices:

X Generic port PMA designator. When X is used in a state diagram its value indicates the particular instance of a generic function.

UPPER	Indicates the upper PMA.
ALLPORTS	Indicates that all port PMAs are to be considered. All port PMAs must meet a test condition in order for that test to pass.
ALLENABLEDPORTS	Indicates that all port PMAs that are not disabled by the Jabber Function are to be considered. All such port PMAs must meet a test condition in order for that test to pass.
ONEPORT	Indicates that all port PMAs that are not disabled by the Jabber Function are to be considered. One, but not more than one, such port PMA must meet a test condition in order for that test to pass.
>ONEPORT	Indicates that all port PMAs that are not disabled by the Jabber Function are to be considered. Two or more such port PMAs must meet a test condition in order for that test to pass.
N	Defined by the PORT function on exiting from the UPWARD IDLE state of Fig 12-13. It indicates which port PMA caused the exit from the UPWARD IDLE state.
<i>(2) Port Functions:</i>	
PORT(TestCondition)	Returns the index of a port PMA passing the indicated test condition. If multiple port PMAs meet the test condition, the PORT function will return one and only one of the acceptable values.
<i>(3) Input Variables:</i>	
INPUT(X)	Indicates the state of activity on the designated PMA input channel. It may be either "idle" or "active." The former indicates that <i>input_idle</i> is asserted, the latter indicates that it is not asserted.
input(X)	Used to receive an <i>input</i> message (see 12.3.2.1) from the designated PMA input channel.
probation_alternative	Used to distinguish between the two allowed alternatives for exiting the JABBER JAM state of Fig 12-14 when an active port becomes idle. The implementor of a hub may treat the variable as either true or false.
<i>(4) Output Variables:</i>	
output(X)	Used to send an <i>output</i> message (see 12.3.3.1 and 12.4.3.1) to the designated PMA output channel.
output_idle(X)	Used to send an <i>output_idle</i> message (see 12.3.3.1) on the designated PMA output channel.
<i>(5) Inter Process Flags:</i>	
send_collision	Used by the Upward Signal Transfer Function to indicate a series of <i>output</i> messages to the upper PMA sublayer, the effect of which is to transmit the CP signal, as described in 12.3.2.4.2, 12.3.2.4.3, and 12.4.3.2.7.
jabber_collision	Used by the various instances of the Jabber Function to signal the Upward Signal Transfer Function that CP should be generated.
disable_input(X)	Used to disable the designated PMA input channel. The input is re-enabled when <i>disable_input(X)</i> is no longer asserted. Only the Upward Signal Transfer Function is affected by the disabling of a port (via the ALLENABLEDPORTS, ONEPORT, and >ONEPORT designators).

<code>jabberTime1</code>	Used by the Jabber Function (see 12.4.3.2.3) to detect excessively long transmissions. It is started by "start_jabberTime1." "jabberTime1_done" is satisfied when the timer has expired.
<code>jabberTime2</code>	Used by the Jabber Function (see 12.4.3.2.3) to determine when to disable ports due to excessively long transmissions. It is started by "start_jabberTime2." "jabberTime2_done" is satisfied when the timer has expired.

12.4.3.2.2 Upward Signal Transfer Function. The Upward Signal Transfer Function combines signals from the various port inputs and passes them on to the upper output. It also detects and reports collisions as appropriate. The state diagram of Fig 12-13 depicts its operation.

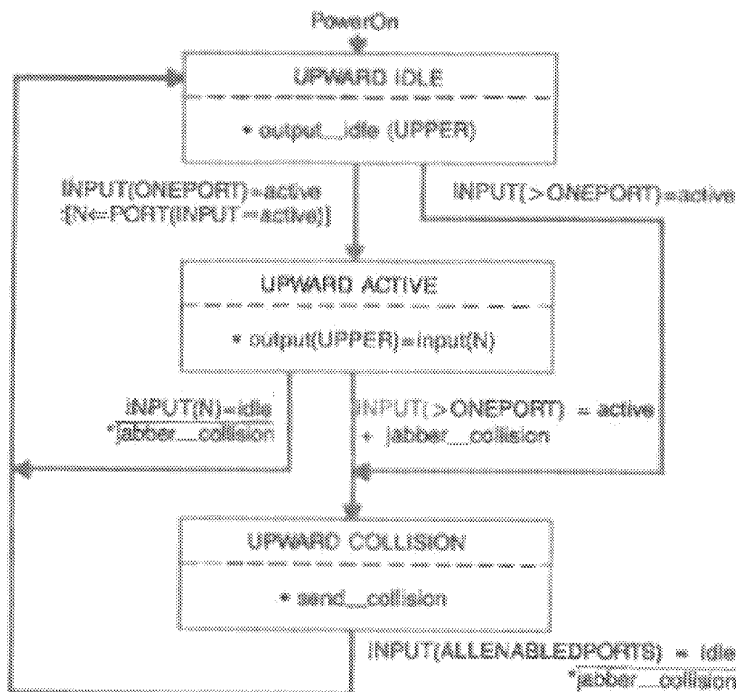

Fig 12-13
Hub PLS Upward Transfer Function

Signals are propagated upward according to the following rules, except as controlled by the Jabber Function (see 12.4.3.2.3):

- (1) If IDL is present on all port inputs, then transmit IDL.
- (2) If IDL is present on all but one of the port inputs, then repeat the signal received from that one line. If that one signal is CP, then a hub may generate its own CP signal instead of repeating the received CP signal.
- (3) If two or more inputs are active (non-IDL) at the same time, then transmit CP and continue transmitting CP until all inputs indicate IDL again.

Whenever the hub finishes transmitting CP, it shall then transmit IDL, including the extended HI period.

12.4.3.3 Jabber Function. The Jabber Function detects abnormally long transmissions and takes appropriate action to abort them. The state diagram of Fig 12-14 depicts its operation.

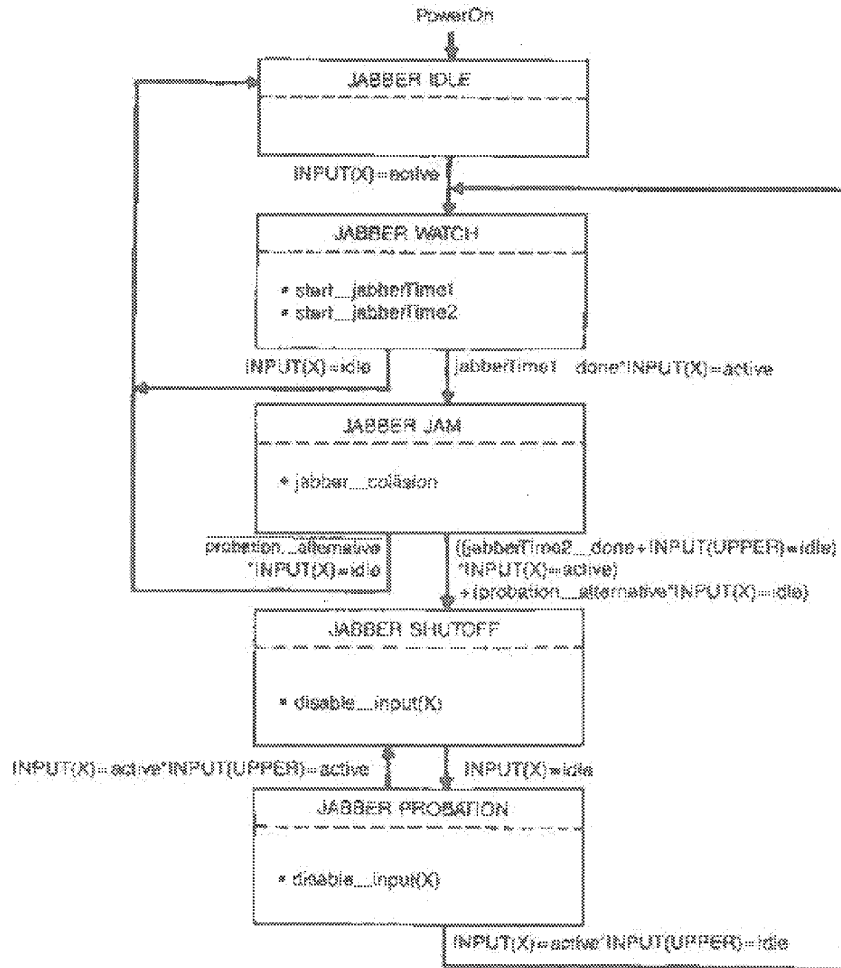

Fig 12-14
Hub PLS Jabber Function for Port X

Two timers are used by the Jabber Function. They may be implemented either as local timers for each instance of the Jabber Function or as global timers shared by all instances. Furthermore, because the two timers are always started concurrently, an implementation may share circuitry between the two.

The first timer is started by "start_jabberTime1" and asserts "jabberTime1_done" after 25 to 50 ms since starting. If implemented as a single global timer, assertion of start_jabberTime1 by any instance of the Jabber Function with any other instance(s) still waiting for that timer shall not restart the timer, thereby shortening the waiting period for the latest instance.

Similarly, the second timer is started by "start_jabberTime2" and asserts "jabberTime2_done" after 51 to 100 ms since starting. If implemented as a single global timer, assertion of start_jabberTime2 by any instance of the Jabber Function with any other instance(s) still waiting for that timer shall not restart the timer, thereby shortening the waiting period for the latest instance. Furthermore, (if this second timer is implemented as a single global timer, then assertion of start_jabberTime1 by any instance of the Jabber Function with any other instance(s) still waiting for just the second timer (or the JABBER JAM state) shall

be treated as if the first timer expires immediately (asserting `jabberTime1_done`) for the latest instance, thereby causing that instance to join the other instance(s) waiting for the second timer.

Hardware within the upward side of a hub shall provide a window of 25 to 50 ms, during which time a normal packet or CP sequence may be propagated upward. If any port input (or, as an alternative implementation, the hub's combined upward signal) exceeds this duration without becoming idle, then the hub shall switch to transmitting CP until 51 to 100 ms after the beginning of the window and then, if that input is still active, disable that input (or all nonidle inputs) until it once again becomes active while the downward side is idle.

The "probation_alternative" input variable is used to distinguish between the two allowed alternatives for exiting the JABBER JAM state of Fig 12-14 when an active port becomes idle. The implementor of a hub may treat the variable as either true or false. If true, the port will enter the JABBER PROBATION state (via the JABBER SHUTOFF state); if false, the port will instead return to the JABBER IDLE state.

12.4.3.2.4 Downward Signal Transfer Function. The Downward Signal Function repeats signals from the upper input to the various port outputs. The state diagram of Fig 12-15 depicts its operation.

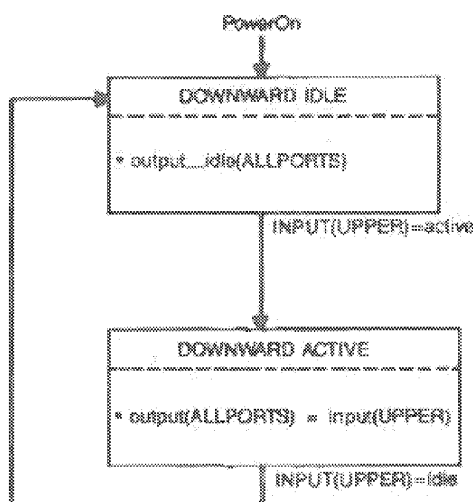

Fig 12-15
Hub PLS Downward Transfer Function

The downward side of a hub may detect the Collision Presence signal at the upper input and generate its own CP signal to be transmitted at the port outputs (in place of repeating the received CP signal).

Whenever the hub finishes transmitting CP, it shall then transmit IDL, including the extended HI period.

12.4.3.2.5 Retiming (Jitter Removal). Each side of each hub shall retime any clocked signals that it propagates so that the transitions occur on half-bit-time boundaries, thereby avoiding accumulation of excessive jitter. Such retiming shall preserve the sequence of CD0, CD1, CVL, and CVH symbols being propagated.

If an ambiguity exists in the incoming bit cells due to excessive noise or jitter, then the appropriate side of the hub may either switch to generating CP or replace the erroneous bit cell with an arbitrary combination of half or whole bit cells.

Retiming also accounts for differences (if any) in clock rates between that used to send bit cells to the hub and that used to send them out from the hub. Excessive differences in clock rates (caused by clocks not meeting 12.3.2.4.1) and excessively long packets (caused by exceeding `maxFrameSize`) may each cause the capacity of the retiming function to be exceeded. In such circumstances, the appropriate side of the hub may either switch to transmitting CP or add or delete half or whole bit cells as needed.

Whenever bit cells are added, deleted, or replaced, the hub shall maintain synchronization of the outgoing bit cells to a half or whole bit cell boundary. Furthermore, it shall not generate periods of more than one bit time without a transition.

12.4.3.2.6 Header Hub Wrap-Around. For each particular network configuration, one hub operates as the header hub and all others as intermediate hubs. It is suggested, but not required, that hub implementations be capable of being used for either purpose. Methods for switching between these two modes are beyond the scope of this standard.

For an intermediate hub, the upper output shall be connected to a port input of the next higher-level hub and the upper input shall be connected to a port output of a higher-level hub.

For the header hub, the upper output shall be connected to the upper input. This wraparound may appropriately bypass parts of the PMA specification so long as the resulting implementation is functionally equivalent to one with a wired connection. For example, signals internal to the hub need not be translated to the corresponding external levels and then translated back to internal levels. Similarly, it shall not be necessary to retime the wrapped signal twice, once in the upward side and then again in the downward side of the same header hub; a single retiming is permissible.

12.4.3.2.7 Collision Presence Startup. When a hub starts generating CP (as specified in 12.4.3.2.2 through 12.4.3.2.5) it shall synchronize the startup to a half or whole bit-cell boundary of any immediately preceding signal. If it was sending IDL immediately before the CP, no synchronization or preamble is required.

A hub may start transmission of CP at any point in the sequence that does not result in periods of more than one bit time without a transition during the switch from passing on data to sending CP. Depending on the preceding signal, it may start with L010H, 010HL, 101HL, 0HL0I, or HL0I0. Because startup may be synchronized to any half-bit-cell boundary, a hub may also transmit the shifted version of CP starting with 1LH10, LH10I, H10IH, 10ILH, or 0ILHI.

12.4.3.3 Reliability. Hubs shall be designed to provide a mean time between failure (MTBF) of at least 45 000 hours of operation. Hubs, including the associated connectors and other passive components, should be designed to minimize the probability that a particular failure results in total network failure. Furthermore, the port electronics of each hub should be designed so as to minimize the probability that the failure of one port prevents communication by equipment attached to the other ports.

12.5 Physical Medium Attachment (PMA) Specification

12.5.1 Overview. This section defines the Physical Medium Attachment (PMA) sublayer for 1BASE5. The relationship of this specification to the entire standard is shown in Fig 12-16. The PMA sublayer connects the PLS sublayer to the Medium Dependent Interface (MDI).

12.5.2 PLS-PMA Interface. The interface between the PLS and the PMA sublayers is specified in 12.3.2.1 for DTEs and in 12.4.3.1 for hubs.

12.5.3 Signal Characteristics

12.5.3.1 Transmitter Characteristics. Transmitters should operate properly when loaded with any cable meeting the requirements of 12.7. To approximate the boundary conditions of such loading, two specific test loads are specified. Transmitters shall meet all requirements of this section when connected to both the "light" (115 Ω) load shown in Fig 12-17 and the "heavy" (approximately 80 Ω) load shown in Fig 12-18. It is expected that transmitters that perform correctly with these two loads will also perform acceptably under intermediate loading conditions.

12.5.3.1.1 Differential Output Voltage. For simplicity of explanation, the text and figures of this section describe the differential output voltage in terms of voltage magnitudes. The requirements of this section apply to the negative pulses as well as the positive ones.

Beginning with the second bit of the preamble (or CP if no preamble is present), pulses of duration BT/2 shall meet the conditions of Fig 12-19. Pulses of duration BT shall meet the conditions of Fig 12-20. After the zero-crossing, the output shall exceed the voltage of a signal rising from the zero-crossing to 2.0 V with

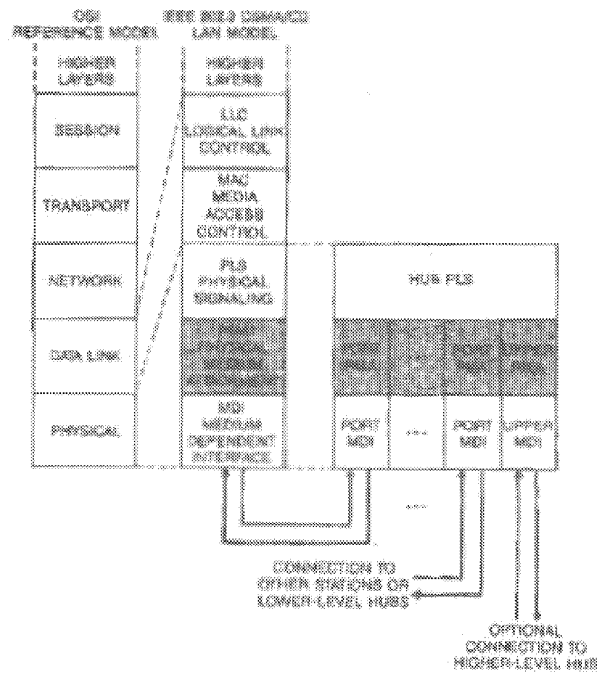

Fig 12-16
 Physical Medium Attachment, Relationship to the OSI Reference Model
 and the IEEE 802.3 CSMA/CD LAN Model

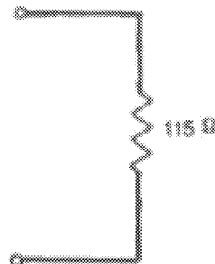

Fig 12-17
 Simulated Light Load

a slope of magnitude 20 mV/ns. The output shall remain above 2.0 V until 100 ns before the next, zero-crossing. The peak output voltage shall not exceed 3.65 V. While falling from 2.0 V to the zero-crossing, the signal shall exceed the voltage of a signal falling from 2.0 V to the zero-crossing with a slope of magnitude 20 mV/ns.

For pulses of duration BT , the average voltage that appears from 100 ns after the zero-crossing through $BT/2$ shall be between 0.95 and 1.8 times the average voltage that appears from time $BT/2$ through 100 ns before the following zero-crossing. Similarly, for pulses of duration BT , the peak voltage that appears from 100 ns after the zero-crossing through $BT/2$ shall be between 0.95 and 1.8 times the peak voltage that appears from time $BT/2$ through 100 ns before the following zero-crossing.

NOTE: The purpose of the above restrictions on average and peak voltages is to avoid transmitter waveforms that peak excessively during the second half of signals of duration BT , resulting in excessive jitter at the receiver. Some equalizations to produce slight droop in the second half of signals of duration BT , on the other hand, may help decrease jitter at the far end of long cables.

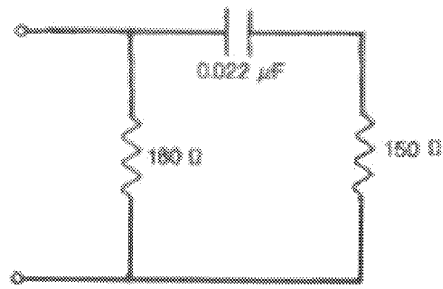

Fig 12-18
Simulated Heavy Load

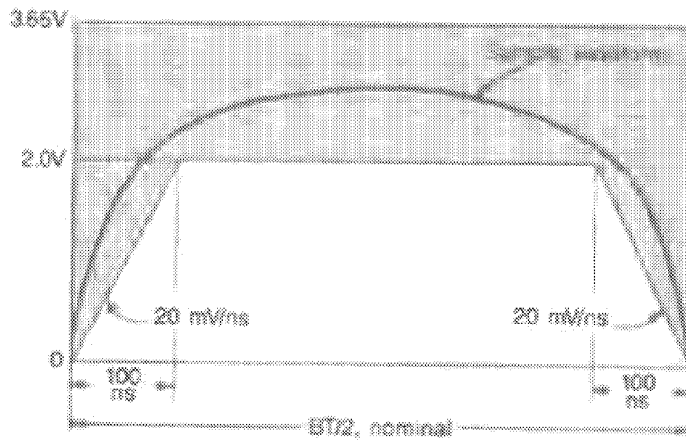

Fig 12-19
Differential Output Voltage, Nominal Duration BT/2

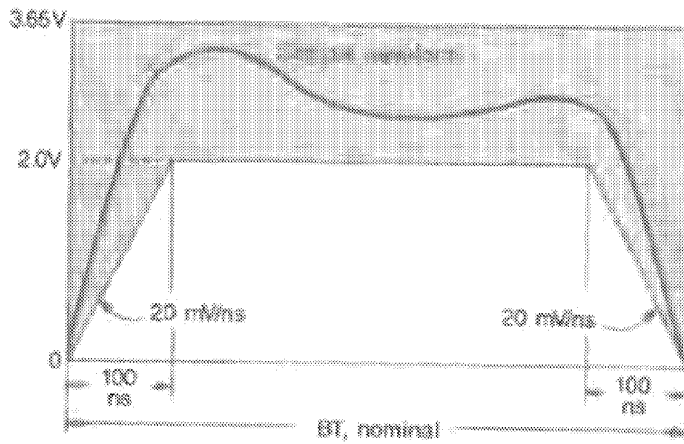

Fig 12-20
Differential Output Voltage, Duration BT

The amplitude of the power spectrum at the output of the transmitter for all possible sequences of signals shall not exceed that produced by an idealized transmitter sending corresponding rectangular waveforms with magnitude 365 V at any frequency.

When a transmitter enters the idle state, it shall maintain a minimum differential output voltage of 2.0 V from 100 ns through 2BT after the last low-to-high transition, as illustrated in Fig 12-21. The differential output voltage shall then fall to 1.1 V within 3BT after that same low-to-high transition. Starting when the differential output voltage first reaches 1.1 V, the magnitude of the output voltage driven into the test loads indicated in Figs 12-22 and 12-23 shall then remain within the limits indicated in Fig 12-21 until the transmitter leaves the idle state.

The transmitter output at the start of idle may exhibit overshoot, ringing, slow voltage decay, or a combination thereof due to the following factors:

- (1) Change in transmitter source impedance between the active and idle states
- (2) Difference in the magnitudes of the differential output voltage between the high and low output states (ΔV_{OD})
- (3) Waveform asymmetry at the transmitter (ΔT)
- (4) Transmitter and receiver (transformer) inductance (L)

NOTE: The contribution to the undershoot from each of these can be computed with the following equations:

$$V_{\Delta V_{OD}} = \Delta V_{OD} \cdot R_{OFF} / 2R_{ON}$$

$$V_{\Delta T} = (\Delta T / 1000 \text{ ns}) \cdot V_p \cdot R_{OFF} / R_{ON}$$

$$V_L = V_p \left(1 - e^{-2.76 \text{ ns} \cdot (L/R_{ON})} \right) \cdot R_{OFF} / R_{ON}$$

where:

$$R_{OFF} = R_{SOURCE OFF} \parallel R_L$$

$$R_{ON} = R_{SOURCE ON} \parallel R_L$$

$R_{SOURCE OFF}$ = source impedance (Ω) when the driver is off

$R_{SOURCE ON}$ = source impedance (Ω) when the driver is on

R_L = load impedance (Ω)

L_p = combined inductance (μH) of the transmitter and receiver transformers

ΔV_{OD} = difference (V) in magnitude of the HI and LO output voltages

ΔT = asymmetry of the waveform equals the difference between the average HI and average LO pulse widths (ns) at the transmitter

V_p = maximum output voltage (V) during the start of IDL

NOTE: The waveform shown in Fig 12-21 and the equations in the preceding note apply to a transmitter connected to the test loads of Figs 12-22 and 12-23. An actual receiver may present a more complex termination impedance and so the undershoot or overshoot may exceed that encountered with the test loads.

12.5.3.1.2 Output Timing Jitter. The transmitted signal zero-crossings shall deviate from the idealized zero-crossings by no more than ± 10 ns.

12.5.3.1.3 Transmitter Impedance Balance. The longitudinal to metallic impedance balance of the transmitter, defined as $20 \log_{10}(E_{\text{ext}}/E_{\text{diff}})$, where E_{ext} is an externally applied ac voltage, as shown in Fig 12-24, shall exceed 44 dB at all frequencies up to and including 4BR in the idle and nonidle states.

NOTE: It may be difficult to measure the transmitter impedance balance in the nonidle state. A frequency-selective wavemeter or other measurement technique may be required. Furthermore, the balance of the test equipment (such as the matching of the 400 Ω resistors) must exceed that required of the transmitter.

12.5.3.1.4 Common-Mode Output Voltage. The magnitude of the total common-mode output voltage of the transmitter, E_{cm} , measured as shown in Fig 12-25, shall not exceed 300 mV.

NOTE: The implementor should consider any applicable local, national, or international regulations and standards concerning RF emission. Driving unshielded twisted pairs with high-frequency common-mode voltages may result in interference to other equipment.

12.5.3.1.5 Common-Mode Tolerance. Transmitters shall meet the requirements of 12.5.3.1.1 and 12.5.3.1.2 even in the presence of common-mode sinusoidal voltage, E_{cm} (as shown in Fig 12-26), of ± 20 V peak at frequencies from 40 kHz through 6BR.

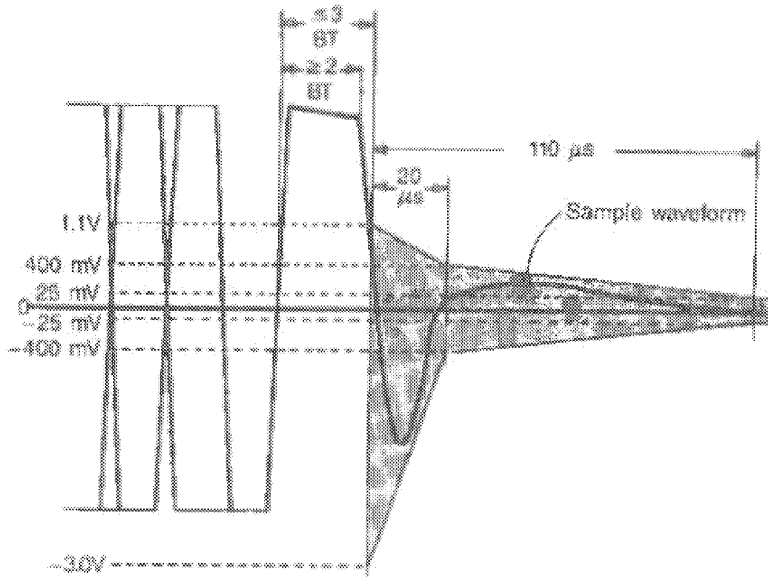

Fig 12-21
Transmitter Waveform for Idle

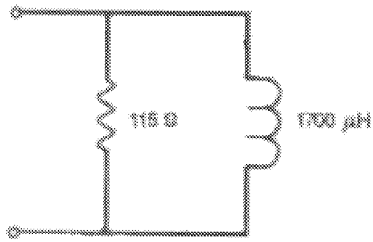

Fig 12-22
Start-of-Idle Test Load #1

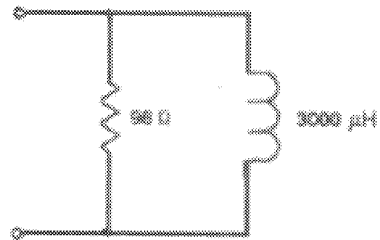

Fig 12-23
Start-of-Idle Test Load #2

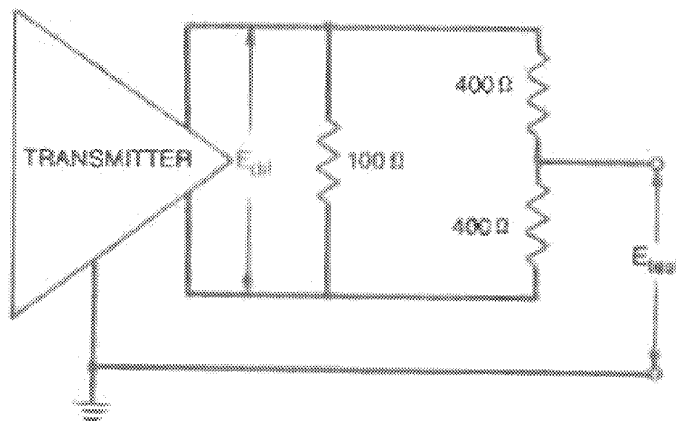

Fig 12-24
Transmitter Impedance Balance

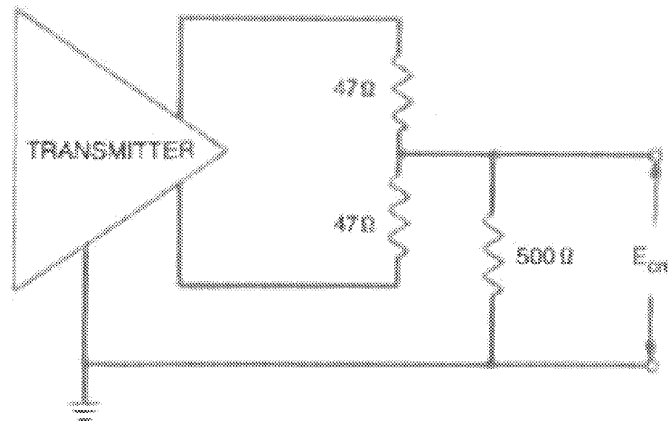

Fig 12-25
Common-Mode Output Voltage

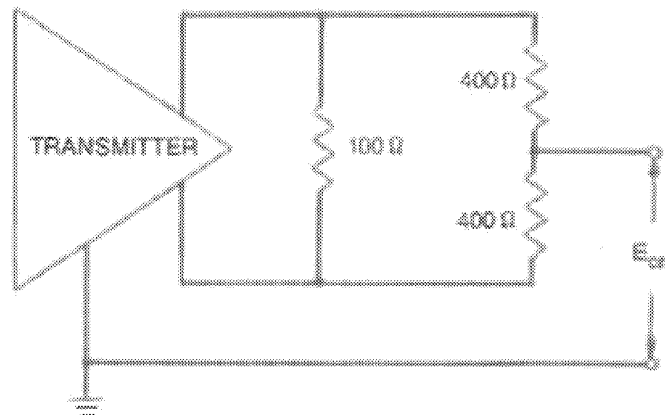

Fig 12-26
Transmitter Common-Mode Tolerance

12.5.3.1.6 Transmitter Fault Tolerance. Transmitters, both when idle and when nonidle, shall tolerate the application of short circuits across their outputs for an indefinite period of time without damage and shall resume normal operation after such faults are removed. The magnitude of the current through such a short circuit shall not exceed 300 mA.

Transmitters, both when idle and when nonidle, shall withstand, without damage, a 1000 V common-mode impulse of either polarity, applied as indicated in Fig 12-27. The shape of the impulse shall be 0.3/50 μ s (300 ns virtual front time, 50 μ s virtual time of half value), as defined in IEC Publication 60 (see Reference (11)).

NOTE: Tolerance of, and recovery from, the application of the telephony voltages described in 12.10.2 is optional, but the safety requirements of that section are mandatory.

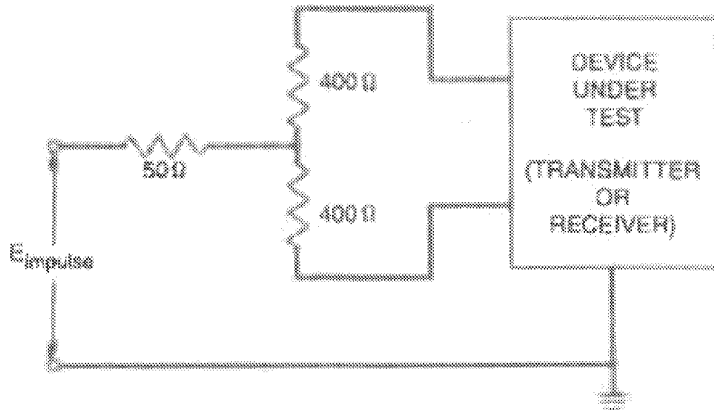

Fig 12-27
Common-Mode Impulse Test

12.5.3.2 Receiver Characteristics

12.5.3.2.1 Differential Input Voltage. The receiver shall operate properly when a signal meeting the minimum magnitude requirements of Fig 12-28 is received. When less than 300 mV, the magnitude of the voltage will exceed that of a straight line through the nearest zero-crossing with slope of magnitude 9 mV/ns. That is, the average slew rate near each zero-crossing will exceed 9 mV/ns. The magnitude of the voltage will also remain at or above 1.0 V for some period lasting at least 150 ns (650 ns for pulses of duration BT) that starts within 250 ns of the preceding zero-crossing and its peak will be at least 1.1 V.

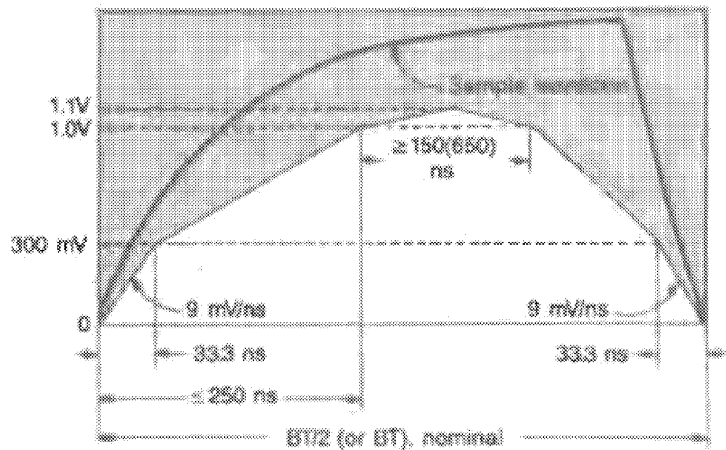

Fig 12-28
Receiver Signal Envelope

12.5.3.2.2 Input Timing Jitter. Receivers shall operate properly with zero-crossing jitter of up to ± 32 ns from the ideal.

12.5.3.2.3 Idle Input Behavior. The IDL condition shall be detected within 1.8 bit times of the last low-to-high transition at the receiver.

NOTE: (1) It is necessary to distinguish CVH from IDL.

(2) System jitter considerations make it impractical to detect IDL (start, end-of-transmission delimiter) any sooner than 1.8 bit times. The specific implementation of the clock recovery mechanism, or equivalent, determines the lower bound on the actual IDL detection time. Adequate margin should be provided between the lower bound and 1.8 bit times.

The receiver shall take precautions to ensure that the HI-to-silence transition of the start of IDL is not falsely interpreted as a silence-to-nonidle transition, even in the presence of signal droop, overshoot, ringing, slow voltage decay, or a combination thereof due to capacitive and inductive effects in the transmitter, cable, and receiver, including those discussed in 12.5.3.1.1.

To this end, a receiver in a hub shall treat its input as if it were idle for between 20 and 30 μ s after detecting IDL. The timing of this "protection" period for the port PMAs may use a single timer that is started when all ports have become idle or disabled by the Jabber Function. Receivers in DTEs may include a similar protection period of up to 30 μ s.

NOTE: This protection period is required in hubs because erroneously interpreting the start-of-idle as a new transmission will result in propagation of the error to DTEs, despite any precautions taken in those DTEs. This protection period is optional in DTEs because any implementation error in a DTE will affect only that particular DTE.

12.5.3.2.4 Differential Input Impedance. The (complex) differential input impedance of the receiver, Z_{receiver} , shall be such that the reflection attenuation, defined as $20 \log_{10} (|Z_{\text{receiver}} + Z_{\text{cable}}| / |Z_{\text{receiver}} - Z_{\text{cable}}|)$, where Z_{cable} is the differential characteristic impedance of the attached cable, exceeds 18 dB over the range $BR/2$ through $2BR$ for all cables meeting the requirements of 12.7.2.

12.5.3.2.5 Common-Mode Rejection. Receivers shall assume the proper output state for any differential input signal, E_d , that results in a signal, E_{diff} , that meets 12.5.3.2.1 and 12.5.3.2.2, even in the presence of common-mode sinusoidal voltages, E_{cm} (as shown in Fig 12-29), of ± 20 V peak at frequencies from 40 kHz through 6BR.

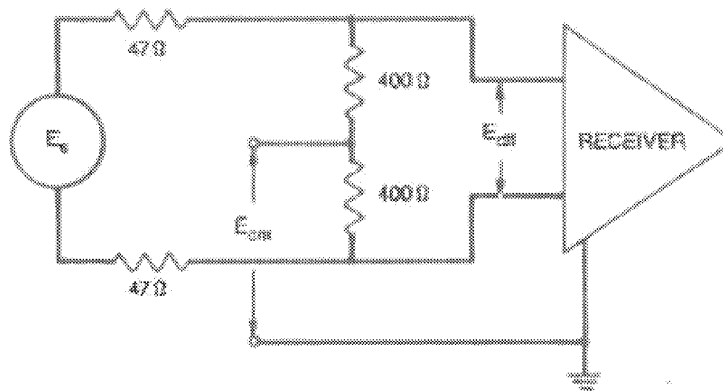

Fig 12-29
Receiver Common-Mode Rejection

12.5.3.2.6 Noise Immunity. Receivers shall meet the following limits on average error rates when the noise described in 12.7.4 is added to the signals described in 12.5.3.2.1 and 12.5.3.2.2:

- (1) When nonidle, the receiver error rate shall not exceed one error in 10^6 bits.
- (2) When idle, a receiver used in a DTE shall not falsely detect carrier more than one in 100 s.
- (3) When idle, a receiver used in a hub shall not falsely detect carrier more than once in 1500 s.

NOTE: Receivers whose inputs include a 2-4 MHz, 2-pole, low-pass, Butterworth filter and a 500 mV squelch level will meet this last requirement for idle-mode noise immunity yet still perform properly with the weakest signal allowed by 12.5.3.2.1.

12.5.3.2.7 Receiver Fault Tolerance. Receivers shall tolerate the application of short circuits across their inputs for an indefinite period of time without damage and shall resume normal operation after such faults are removed.

Receivers shall withstand, without damage, a 1000 V common-mode impulse of either polarity, applied as indicated in Fig 12-27. The shape of the impulse shall be 0.3/50 μ s (300 ns virtual front time, 50 μ s virtual time of half value), as defined in IEC Publication 60 (see Reference [11]).

NOTE: Tolerance of, and recovery from, the application of the telephony voltages described in 12.10.2 is optional, but the safety requirements of that section are mandatory.

12.6 Medium Dependent Interface (MDI) Specification

12.6.1 Line Interface Connector. 8-pin connectors meeting the requirements of Section 3 and Figs 1 through 5 of ISO/DIS 8877 (see Reference [16]) shall be used as the compatibility interface between the PMA and the medium. The use of other types of connectors, if any, within a PMA or within the medium, although not explicitly prohibited, is outside the scope of this standard.

12.6.2 Connector Contact Assignments. The contacts of the connectors, as depicted in Figs 12-30 and 12-31, shall correspond to signaling circuits as indicated below:

Contact	Signal
1	Upward Data+ (positive for HI signal)
2	Upward Data- (negative for HI signal)
3	Downward Data+ (positive for HI signal)
4	not used by 1BASE5
5	not used by 1BASE5
6	Downward Data- (negative for HI signal)
7	reserved
8	reserved

For DTEs and the upper MDI of hubs, contacts 1 and 2 are used for transmitting and contacts 3 and 6 are used for receiving. For the port MDIs of hubs, however, contacts 1 and 2 are used for receiving and contacts 3 and 6 are used for transmitting.

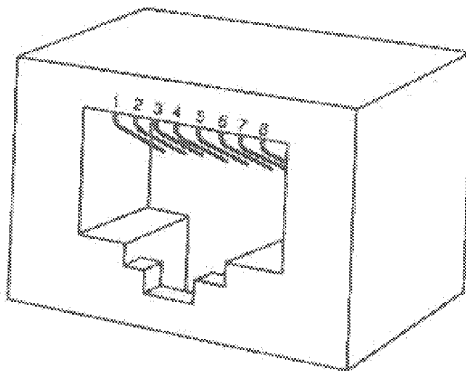

Fig 12-30
DTE and Hub Connector

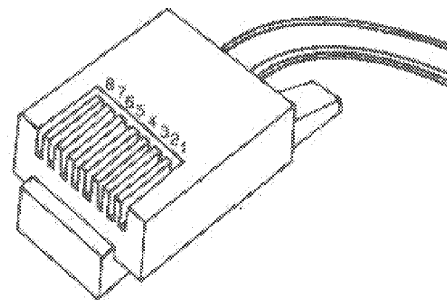

Fig 12-31
Cable Connector

12.6.3 Labeling. To distinguish 1BASE5 connectors from those used for other purposes, it is recommended that appropriate labels be affixed to wall outlets and other connectors. This is particularly important in environments in which the specified 8-contact connectors are used for more than one purpose.

12.7 Cable Medium Characteristics

12.7.1 Overview. A significant number of BASE5 networks are expected to utilize in-place building wiring. In this environment, DTEs connect to wall outlets using twisted pair telephone cord. The wall outlets, in turn, connect to wiring closets, where hubs could be located, using standard telephone wiring. This wiring typically consists of 0.4–0.6 mm diameter (26–22 gauge) unshielded twisted pairs.

12.7.2 Transmission Parameters. Each wire pair used to interconnect DTEs and hubs shall meet the requirements of 12.9.3 and also have the following characteristics.

12.7.2.1 Attenuation. Total cable attenuation between a transmitter and the corresponding receiver shall be no more than 6.5 dB at all frequencies between BR/2 and BR, 9.2 dB at frequencies between BR and 2BR, and 13.8 dB at frequencies between 2BR and 4BR.

12.7.2.2 Differential Characteristic Impedance. The magnitude of the differential characteristic impedance at frequency BR, Z_{BR} , of each wire pair used shall be between 80 Ω and 115 Ω . In addition, the magnitude and phase angle of the characteristic impedance at each of the following frequencies shall be within the corresponding ranges indicated:

Frequency	Magnitude		Phase Angle	
	Minimum	Maximum	Minimum	Maximum
BR/4	Z_{BR}	$Z_{BR} + 7 \Omega$	-10°	0°
BR/2	Z_{BR}	$Z_{BR} + 5 \Omega$	-8°	0°
BR	Z_{BR}	Z_{BR}	-6°	0°
2BR	$Z_{BR} - 4 \Omega$	Z_{BR}	-4°	0°
4BR	$Z_{BR} - 5 \Omega$	Z_{BR}	-3°	0°

12.7.2.3 Medium Timing Jitter. Intersymbol interference and reflections due to impedance mismatches between the sections of a cable segment can introduce jitter in the timing of the zero-crossings. A cable segment terminated in 96 Ω shall add no more than ± 17 ns, referenced to the transmit clock, of edge jitter when driven with a rectangular signal of magnitude 2.5 V through a source impedance 22 Ω . The driving signal shall be a Manchester-encoded pseudo-random sequence of data with a repetition period of at least 511 bits.

NOTES: (1) The reflections caused by splicing two cable sections that have different characteristic impedances (but that each meet the requirements of 12.7.2.2) will not contribute significantly to timing jitter if the splice is within 10 m of either end of the segment.

(2) Branches off a wire pair (often referred to as "bridged taps" or "stubs") will generally cause excessive jitter and so should be avoided.

(3) Jitter can be measured at the receiving end of a segment using an oscilloscope. The oscilloscope is triggered on zero-crossings; the deviation of subsequent zero-crossings from multiples of $1/T_C$ is then observed. The deviation of each zero-crossing must not exceed ± 34 ns.

12.7.2.4 Dispersion. Each wire pair shall produce an output signal that meets the zero-crossing edge rate described in 12.5.3.2.1 when driven with a 1 MHz trapezoidal signal of magnitude 3.0 V (that is, 4.0 V peak-to-peak) with edge rate 20 mV/ns.

12.7.3 Coupling Parameters. To avoid excessive coupling of signals between pairs of a cable, the crosstalk and imbalance must be limited.

Crosstalk attenuation is specified with the far end of both the disturbed and the disturbing pairs and the near end of the disturbed pair terminated in 96 Ω .

12.7.3.1 Pair-to-Pair Crosstalk. The near-end, differential, crosstalk attenuation between each wire pair and each other pair in the same cable shall be at least 45 dB frequencies up to BR and at least $45 - 15 \log_{10}(f/BR)$ dB for each frequency f between BR and 4BR.

12.7.3.2 Multiple-Disturber Crosstalk. The near-end, differential, crosstalk attenuation between multiple disturbing wire pairs and a disturbed pair in the same cable shall be at least 38.5 dB at frequency BR and at least $38.5 - 15 \log_{10}(f/BR)$ dB for each frequency f between BR and 4BR.

When two or more disturbers are present in a common cable sheath, the multiple-disturber, near-end, crosstalk attenuation (MDNEXT) into each pair, measured in dB, may be determined using the following equations:

$$H_j = \sum_{i=1}^n 10^{(-X_{ij}/20)} \cos \theta_{ij}$$

$$V_j = \sum_{i=1}^n 10^{(-X_{ij}/20)} \sin \theta_{ij}$$

$$\text{MDNEXT}_j = 10 \log_{10}(H_j^2 + V_j^2)$$

where:

i iterates over each disturbing pair

j is the disturbed pair

X_{ij} is the magnitude of the near-end, differential, crosstalk attenuation from pair i to pair j

θ_{ij} is the phase angle of the near-end, differential, crosstalk attenuation from pair i to pair j

If only the probability distribution of X_{ij} is known, then the distribution of MDNEXT can be determined using Monte Carlo methods with that X_{ij} distribution and a phase angle uniformly distributed between 0 and 2π rad.

NOTE: See Appendix A3 for example computations of MDNEXT distributions.

12.7.3.3 Balance. The longitudinal to metallic balance of the cable, defined as $20 \log_{10}(E_{\text{ext}}/2E_x)$, where E_{ext} is an externally applied voltage, as shown in Fig 12-32, shall exceed 44 dB at all frequencies up to 4BR.

NOTE: The balance of the test equipment (such as the balance of the transformer and the matching of the 300 Ω resistors) must exceed that required of the cable.

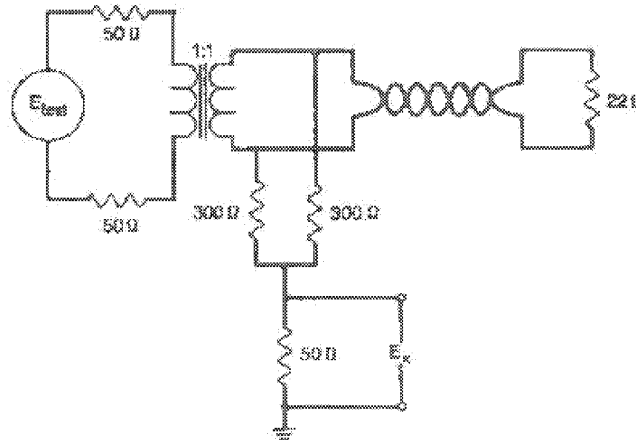

Fig 12-32
Cable Balance Test

12.7.4 Noise Environment. Links used with 1BASE5 shall provide a noise environment no worse than that described below. The total noise environment generally results from two primary contributions: self-crosstalk from other 1BASE5 wire pairs and externally induced impulse noise, typically from telephone ringing and dialing signals, and office machinery. For the purposes of this standard, it can be assumed that the two components contribute independently and so the total error rate can be appropriately split between the two.

12.7.4.1 Impulse Noise. The noise voltage on wire pairs terminated at both ends in 96 Ω , as measured through the following specified filters, shall not exceed the corresponding threshold voltages more than 9 times per 1800 s interval. Following the start of any particular impulse that is counted, any additional impulses shall be ignored (that is, not counted) for a period of 100 μ s. Each filter is a 2-pole Butterworth low-pass filter with the indicated cut-off (3 dB point) frequency.

Cut-Off Frequency	Threshold
2 MHz	170 mV
4 MHz	275 mV
10 MHz	560 mV

The impulse noise occurrence rate changes inversely by one decade for each 7 dB change in the threshold voltage. That is, if the noise occurrence rate is 9 counts per 1800 s at a particular threshold voltage, then a rate of 9 counts per 18 000 s will occur at a threshold 7 dB above that voltage. If a count rate of N counts per 1800 s is measured on a specific cable and filter at the specified voltage threshold, the media noise margin is $7 \log_{10} (9/N)$ dB.

12.7.4.2 Crosstalk. The level of crosstalk noise on a pair depends on the level of the disturbing signal(s) and the crosstalk attenuation from the pair(s) carrying the signal(s). With the maximum transmit level specified in 12.5.3.1, the sinusoidal crosstalk attenuations specified in 12.7.3.1 and 12.7.3.2, and multiple, synchronized, random Manchester disturbers, the peak self-crosstalk (that is, crosstalk from other 1BASE5 signals) noise levels, as measured through the following specified filters, shall be less than or equal to the levels indicated below. Each filter is a 2-pole Butterworth low-pass filter with the indicated cut-off (3 dB point) frequency.

Cut-Off Frequency	Level
2 MHz	105 mV
4 MHz	160 mV

12.8 Special Link Specification

12.8.1 Overview. Some 1BASE5 networks may require extension beyond the limits imposed by 12.7 or, due to the installation environment, may require special media such as optical fiber, high-grade cable, or even free-space transmission. The detailed design of special links that replace standard links for use in such circumstances is beyond the scope of this standard, but the end-to-end characteristics are specified. It shall be the responsibility of the supplier to ensure the proper operation of special links with other 1BASE5 equipment.

12.8.2 Transmission Characteristics. Special links shall meet the overall attenuation, jitter, and dispersion specifications of 12.7.2.1, 12.7.2.3, and 12.7.2.4, respectively. Total noise introduced due to crosstalk or other sources shall not exceed that allowed for standard media, as specified in 12.7.4. To the extent that it affects operability with 1BASE5 transmitters and receivers, special links shall also meet the impedance and balance requirements of 12.7.2.2 and 12.7.3. The delay and preamble loss allowed for special links is specified in 12.9.4.

12.8.3 Permitted Configurations. No more than one special link is permitted in the path between any DTE and the header hub. That is, special links may be installed in parallel but not in series.

NOTE: Special links may be combined with other 1BASE5 components, such as hubs. Such combinations are subject to the performance specifications of this standard only as visible at their external interfaces. For example, explicit MDIs are not required internal to such combinations.

12.9 Timing

12.9.1 Overview. The successful interconnection of multivendor system components mandates that delay and bit loss be allocated fairly and realistically among the various system elements. The balance of this section defines the upper limits of delay and bit loss allocated to each component. These values allow proper operation with the worst-case system configuration of five levels of hubs, special links, maximum-length cable segments throughout the network, and colliding DTEs at extremes of the network.

12.9.2 DTE Timing. DTE Initial Transmit Delay is the time from the first full transition (due to the first OUTPUT_UNIT of preamble) from the MAC to the first full transition (after startup bit loss, if any) at the MDI. This delay shall not exceed 8BT. The start bit loss shall not exceed 1 bit.

DTEs shall correctly receive frames that are preceded by 13 or more bits of preamble plus 8 bits of <sfid>.

There is a delay between the reception of signal at the PMA input of a DTE and operation of the deferral process in the MAC. Therefore, there is a window in which a DTE may fail to defer to a transmission even after it has arrived at the input. The DTE Deference Delay is the time from the receipt of the first transition of the preamble at the MDI until the last moment that the DTE might start transmitting at the MDI. This delay includes the following components:

- (1) The delay from the first input transition at the MDI to CARRIER_ON at the PLS-MAC interface
- (2) The delay through the MAC processes from CARRIER_ON to the last moment that a new transmission would miss being deferred
- (3) The delay from the first OUTPUT_UNIT at the MAC-PLS interface to the first output transition at the MDI

The DTE Deference Delay shall be no more than 21BT.

The DTE Collision Shutdown Delay is the time from the first CVL or CVH arriving at the MDI of a transmitting DTE until that DTE transmits IDL at that interface. This time shall be no more than 24BT + jamSize=58BT. This limit shall not start until after the <sfid> has been transmitted.

12.9.3 Medium Timing. The Medium Transit Delay is the time from when a signal enters the medium until that signal leaves the medium. This delay shall not exceed 4BT.

12.9.4 Special Link Timing. The Special Link Transit Delay is the time from when a signal enters a special link until that signal leaves the special link. This delay shall not exceed 15BT. The preamble leaving a special link shall be no more than 2 bit cells longer than the preamble sent to that special link and no more than 1 bit cell shorter than the preamble sent to that special link. For the purposes of these limits only, the first bit transmitted shall be considered part of the silence of the preceding IDL unless it meets the requirements for the succeeding bits specified in 12.5.3.1.1 and 12.5.3.1.2.

12.9.5 Hub Timing. Hub Startup Delay is the time from when the first bit cell of the preamble arrives at a hub until the first bit cell (also preamble) leaves that hub. This time shall be no greater than 12BT. The preamble sent by a hub shall be no more than 1 bit cell longer than the preamble sent to that hub or more than 4 bit cells shorter than the preamble sent to that hub. For the purposes of these limits only, the first bit transmitted shall be considered part of the silence of the preceding IDL unless it meets the requirements for the succeeding bits specified in 12.5.3.1.1 and 12.5.3.1.2.

Hub Idle Collision Startup Delay applies to any case in which CP arrives preceded by fewer (or no) bit times of preamble than the Hub Startup Delay. The time from arrival of the first bit cell (either preamble or CP) until the first bit cell leaves the hub shall be no greater than 12BT.

Hub Transmit Delay is the time from the arrival of any bit cell at a hub to the transmission of the corresponding bit cell from the hub. This delay shall not exceed 9BT, excluding the cumulative effects of clock tolerance.

The transit (propagation) delay between the upward and downward sides of the Header Hub shall be negligible.

Hub Delay Stretch/Shrink is the increase or decrease in a hub's transit delay due to the effects of differing clock rates. The clock rate tolerance of 0.01% specified in 12.3.2.4.1 and the maximum frame size of 1518 octets specified in 4.4.2.2 yield a maximum stretch or shrink of $(66 + 8 + 1518 \cdot 8) \cdot 0.01\% \cdot 2 < 3BT$, both at any given hub and through an entire network.

Hub Collision Detect Delay is the time required for a hub to detect multiple incoming signals and initiate transmission of CP. The time until transmission of the first CVH or CVL shall be no greater than 21BT.

Hub Active Collision Startup Delay is the time from the arrival of the first CVH or CVL of a CP pattern at a hub that is repeating bit cells until transmission of the first CVH or CVL from the hub. This delay shall be no greater than 12BT in either the upward or downward direction.

Hub Collision Shutdown Delay is the time from IDL arriving at a hub that is passing on or generating CP until that hub starts transmitting IDL. This delay shall be limited to 9BT. The limit is relaxed to 25BT, however, for the upward side of a hub that is generating CP. This extra allowance is made to avoid requiring implementation of a separate <old> detection mechanism in each port of the hub.

12.10 Safety. Implementors are urged to consult the relevant local, national, and international safety regulations to ensure compliance with the appropriate standards. EIA C88-1981 (see Annex [12]) provides additional guidance concerning many relevant regulatory requirements.

Sound installation practice, as defined by applicable codes and regulations, shall be followed. ECMA-97 (see Annex [11]) describes safety requirements for local area networks.

12.10.1 Isolation. Each PMA/MDI interface lead shall be isolated from frame ground. This electrical separation shall withstand at least one of the following electrical strength tests:

- (1) 1500 V (rms) at 50 to 60 Hz for 60 s, applied as specified in Section 5.3.2 of IEC Publication 950 [8].
- (2) 2250 V (dc) for 60 s, applied as specified in Section 5.3.2 of IEC Publication 950 (see Reference [8]).
- (3) A sequence of ten 2400 V impulses of alternating polarity, applied at intervals of not less than 1 s. The shape of the impulses shall be 1.2/50 μ s (1.2 μ s virtual front time, 50 μ s virtual time of half value), as defined in IEC Publication 60 (see Reference [11]).

There shall be no insulation breakdown, as defined in Section 5.3.2 of IEC Publication 950 (see Reference [8]), during the test. The resistance after the test shall be at least 2 M Ω , measured at 500 V (dc).

12.10.2 Telephony Voltages. The use of building wiring brings with it the possibility of wiring errors that may connect telephony voltages to 1BASE5 equipment. Other than voice signals (which are very low voltage), the primary voltages that may be encountered are the "battery" and ringing voltages. Although there is no universal standard that constrains them, the following maximums generally apply:

- (1) Battery voltage to an on-hook telephone line is about -56 V (dc) applied to the line through a balanced 400 Ω source impedance. This voltage is used to power the telephone instrument and detect the off-hook condition. Source inductance can cause large spikes on disconnect.
- (2) Battery voltage to an off-hook telephone line is also about -56 V (dc) applied to the line through a balanced 400 Ω source impedance, but most of the voltage appears across the source impedance because the telephone instrument's impedance is relatively much lower.
- (3) Ringing voltage is a composite signal. The first portion can be up to 175 V peak at 20 to 66 Hz, limited by a 100 Ω source resistance or a 400 to 600 Ω source inductive impedance. The second portion is -56 V (dc) limited by a 300 to 600 Ω source impedance. Large spikes can occur at the start and end of each ring.

Although 1BASE5 equipment is not required to survive such wiring hazards without damage, application of any of the above voltages shall not result in any safety hazard.

NOTE: Wiring errors may impose telephony voltages differentially across the 1BASE5 transmitters or receivers. Because the termination resistance likely to be present across a receiver's input is of substantially lower impedance than an off-hook telephone instrument, however, receivers will generally appear to the telephone system as off-hook telephones. Full ring voltages, therefore, will be applied for only short periods of time. Transmitters that are coupled using transformers will similarly appear like off-hook telephones (though perhaps a bit more slowly) due to low resistance of the transformer coil.

13. System Considerations for Multisegment 10 Mb/s Baseband Networks

13.1 Overview. This section provides information on building multisegment 10 Mb/s baseband networks within a single collision domain. The proper operation of a CSMA/CD network requires network size to be limited to control round-trip propagation delay to meet the requirements of 4.2.3.2.3 and 4.4.2.1, and the number of repeaters between any two Data Terminal Equipments (DTEs) to be limited in order to limit the shrinkage of the interpacket gap as it travels through the network. This section applies only to networks that contain 10BASE-T segments.

NOTE: Information on 10BASE-T is included to begin the process of developing this section. It is intended that 9.6.1 and 10.7.1 be merged into this section in the future and that any new 10BASE segments be added to this section.

13.2 Definitions. Terminology used in Section 13 is defined here:

collision domain. A single CSMA/CD network. If two or more Media Access Control (MAC) sublayers are within the same collision domain and both transmit at the same time, a collision will occur. MAC sublayers separated by a repeater are within the same collision domain. MAC sublayers separated by a bridge are within different collision domains.

link segment. The point-to-point full duplex medium connection between two and only two Medium-Dependent Interfaces (MDIs).

segment. The medium connection, including connectors, between MDIs in a CSMA/CD LAN.

13.3 Transmission System Model. The physical size of a 10BASE-T network, or mixed-media network containing 10BASE-T link segments, is constrained by the limits of individual network components. These limits include the following:

- (1) Cable length and its associated propagation time delay.
- (2) Delay of repeater units (start-up and steady-state).
- (3) Delay of MAUs (start-up and steady-state).
- (4) Interpacket gap shrinkage.
- (5) Delays within the DTE associated with the CSMA/CD access method.

Table 13-1 summarizes the delays for the various network media segments:

Table 13-1
Delays for Network Media Segments

Media Segment Type	Maximum Number of MAUs per Segment	Maximum Segment Length (m)	Minimum Medium Propagation Velocity*	Maximum Medium Delay per Segment (ns)
Coaxial	10BASE6	500	0.77 c	2165
	10BASE2	185	0.65 c	950
Link	FOIRL	1000	0.65 c	5000
	10BASE-T	100 [†]	0.59 c	1000
AUI [‡]	1 DTE/1 MAU	50	0.65 c	257

*c = 3×10^8 m/s

[†]Actual maximum segment length depends on cable characteristics; see 14.1.1.3.

[‡]AUI is not a segment.

In addition, Table 14-1 summarizes the delays for the 10BASE-T MAU; Section 8, the delays for the 10BASE5 MAU; Section 10, the delays for the 10BASE2 MAU; and Section 9, the delays of the fiber optic inter-repeater link (FOIRL) and the repeater.

The following network topology constraints apply for 10BASE-T networks as well as mixed-media networks containing 10BASE-T link segments:

- (1) Repeater sets are required for all segment interconnection.
- (2) MAUs that are part of repeater sets count toward the maximum number of MAUs on a segment.
- (3) The transmission path permitted between any two DTEs may consist of up to five segments, four repeater sets (including optional AUIs), two MAUs, and two AUIs.
- (4) When a network path consists of four repeater sets and five segments, up to three of the segments may be coaxial and the remainder must be link segments (Figs 13-1 and 13-2). When five segments are present, each FOIRL link segment should not exceed 500 m.
- (5) When a network path consists of three repeater sets and four segments, the maximum allowable length of the FOIRL segments is 1000 m each, as specified in 9.9 (Fig 13-3).

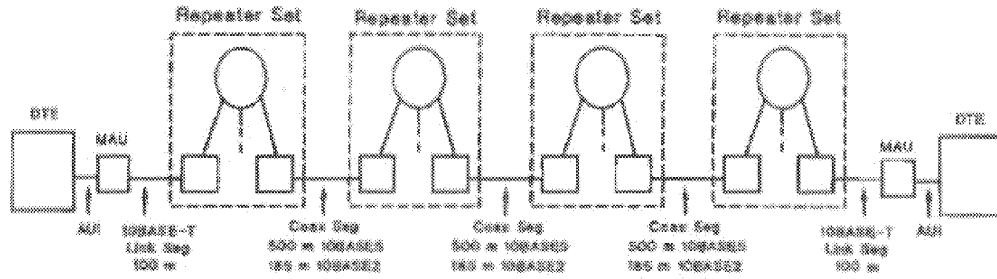

Fig 13-1
Maximum Transmission Path with Three Coaxial Cable Segments

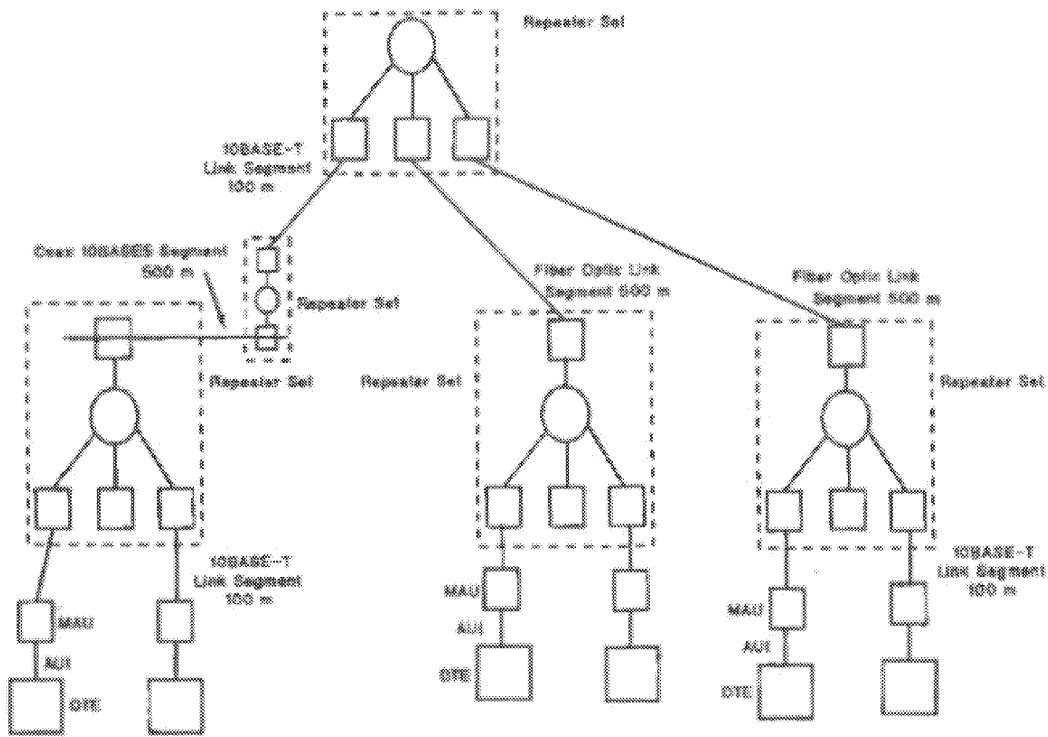

Fig 13-2
Example of Maximum Transmission Path Using Coaxial Cable Segments,
10BASE-T Link Segments, and Fiber Optic Link Segments

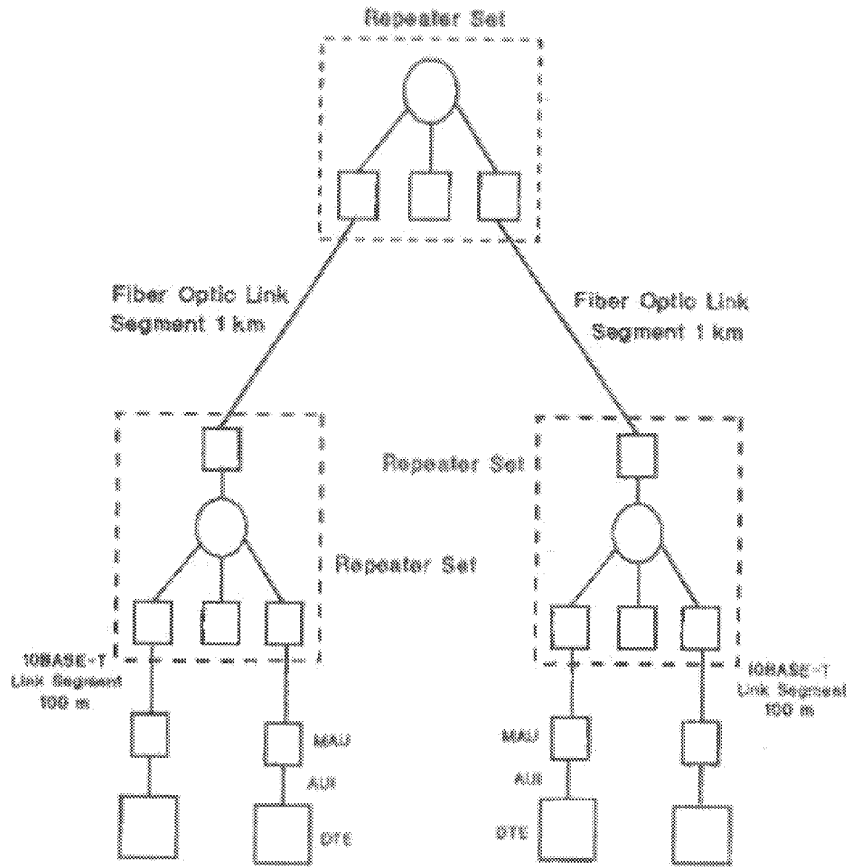

Fig 13-3
Example of Maximum Transmission Path with Three Repeater Sets,
Four Link Segments (Two are 100 m 10BASE-T and Two are 1 km Fiber)

14. Twisted-Pair Medium Attachment Unit (MAU) and Baseband Medium, Type 10BASE-T

14.1 Scope

14.1.1 Overview. Section 14 defines the functional, electrical, and mechanical characteristics of the Type 10BASE-T MAU and one specific medium for use with that MAU. The relationship of this specification to the entire ISO/IEC 8802-3 CSMA/CD Local Area Network Specification is shown in Fig 14.1. The purpose of the MAU is to provide a simple, inexpensive, and flexible means of attaching devices to the medium.

This MAU and medium specification is aimed primarily at office applications where twisted-pair cable is often installed. Installation and reconfiguration simplicity is allowed by the type of cable and connectors used.

The 10BASE-T specification builds upon Sections 1 through 7 and Section 9 of this standard.

14.1.1.1 Medium Attachment Unit (MAU). The MAU has the following general characteristics:

- (1) Enables coupling the Physical Signaling (PLS) sublayer by way of the Attachment Unit Interface (AUI) to the baseband twisted-pair link defined in Section 14.
- (2) Supports message traffic at a data rate of 10 Mb/s.
- (3) Provides for operating over 0 m to at least 100 m (328 ft) of twisted pair without the use of a repeater.
- (4) Permits the Data Terminal Equipment (DTE) or repeater to confirm operation of the MAU and availability of the medium.
- (5) Supports network configurations using the CSMA/CD access method defined in ISO/IEC 8802-3 : 1993 with baseband signaling.
- (6) Supports a point-to-point interconnection between MAUs and, when used with repeaters having multiple ports, supports a star wiring topology.
- (7) Allows incorporation of the MAU within the physical bounds of a DTE or repeater.

14.1.1.2 Repeater Unit. The repeater unit is used to extend the physical system topology and provides for coupling two or more segments. Repeaters are an integral part of all 10BASE-T networks with more than two DTEs (see Figs 13-1 and 13-2). The repeater unit is defined in Section 9. Multiple repeater units are permitted within a single collision domain to provide the maximum connection path length specified in Section 13. The repeater unit is not a DTE and therefore has slightly different requirements for its attached MAUs, as defined in 9.4.1. Repeater sets with 10BASE-T MAUs are required to provide the auto-partition/reconnection algorithm on these ports, as specified in 9.6.6.2.

14.1.1.3 Twisted-Pair Media. The medium for 10BASE-T is twisted-pair wire. The performance specifications of the simplex link segment are contained in 14.4. This wiring normally consists of 0.4 mm to 0.6 mm diameter [26 AWG to 22 AWG] unshielded wire in a multipair cable. The performance specifications are generally met by 100 m of 0.5 mm telephone twisted pair. Longer lengths are permitted providing the simplex link segment meets the requirements of 14.4. A length of 100 m, the design objective, will be used when referring to the length of a twisted-pair link segment.

14.1.2 Definitions. This section defines the terminology specific to Type 10BASE-T MAUs and their application to repeater units.

bit time (BT). The duration of one bit symbol (1/BR).

collision. A condition that results from concurrent transmissions from multiple signal sources.

common-mode voltage. The instantaneous algebraic average of two signals applied to a balanced circuit, both signals referred to a common reference. Also called longitudinal voltage.

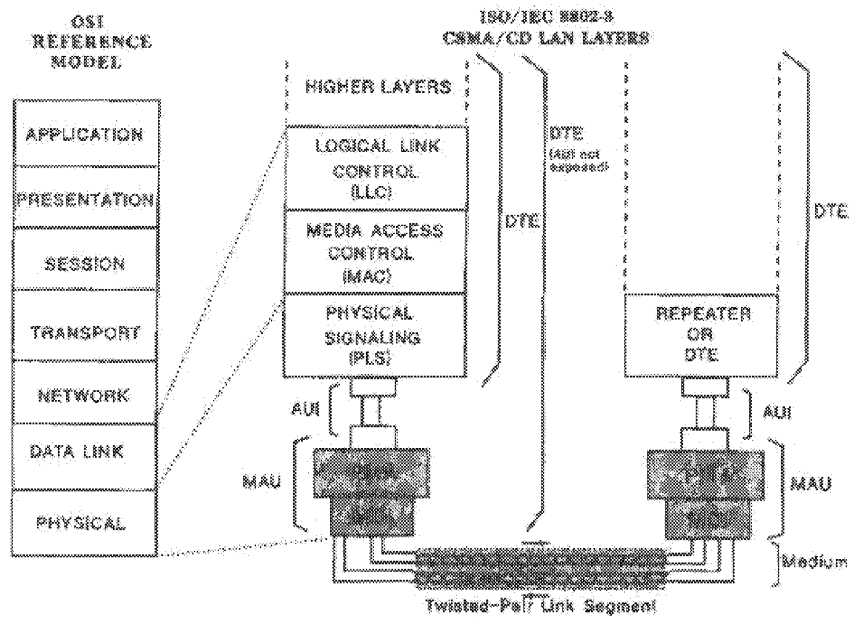

Fig 14-1
10BASE-T Relationship to the ISO Open Systems Interconnection (OSI)
Reference Model and the IEEE 802.3 CSMA/CD LAN Model

cross connect. A group of connection points often wall- or rack-mounted in a wiring closet, used to mechanically terminate and interconnect twisted-pair building wiring.

differential-mode voltage. The instantaneous algebraic difference between two signals applied to a balanced circuit, both signals referred to a common reference. Also called metallic voltage.

Medium-Dependent Interface (MDI). The mechanical and electrical interface between the twisted-pair link segment and the MAU.

Physical Medium Attachment (PMA) sublayer. The portion of the MAU that contains the functional circuitry.

Physical Signaling (PLS) sublayer. The portion of the Physical Layer, contained within the DTE, that provides the logical and functional coupling between the MAU and the Data Link Layer.

simplex link segment. A two-wire path between two MAUs including the terminating connectors, consisting of one or more twisted pairs joined serially with appropriate connection devices, for example, patch fields and wall plates (see Fig 14-2).

twisted pair. Two continuous insulated conductors helically twisted around one another (see Fig 14-2).

twisted-pair cable. A group of twisted pairs within a single protective sheath.

twisted-pair cable binder group. A group of twisted pairs within a cable that are bound together. Large telephone cables have multiple binder groups with high interbinder group near-end crosstalk loss.

twisted-pair link. A twisted-pair link segment and its two attached MAUs (see Fig 14-2).

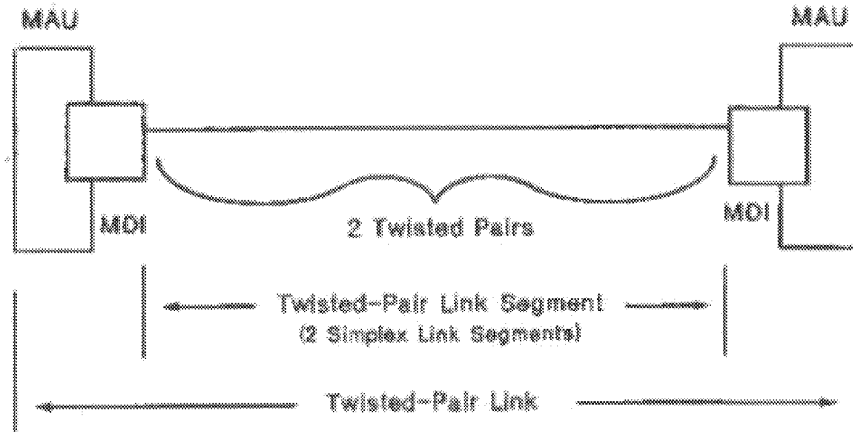

(a)

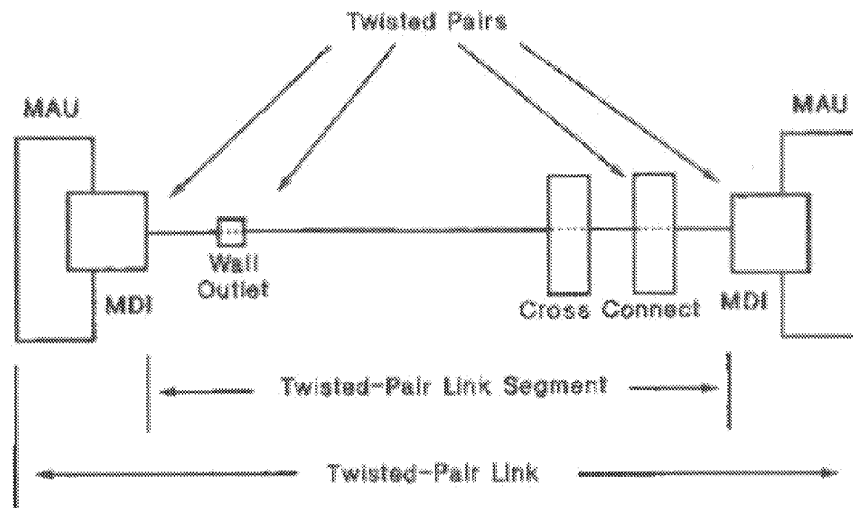

(b)

Fig 14-2
Twisted-Pair Link

twisted-pair link segment (duplex link segment). Two simplex link segments for connecting two MAUs (see Fig 14-2).

14.1.3 Application Perspective. This section states the broad objectives and assumptions underlying the specifications defined throughout Section 14.

14.1.3.1 Objectives

- (1) Provide the physical means for communication between LAN Data Link Layer Entities.
- (2) Ensure compatibility of independently developed physical and electrical interfaces.
- (3) Provide a communication channel with a mean bit error rate, at the physical layer service interface of less than one part in 10^9 .
- (4) Provide for ease of installation and service.
- (5) Ensure that fairness of DTE access is not compromised.
- (6) Provide for low-cost networks, as related to both equipment and cabling.
- (7) Make use of telephone twisted-pair building wiring and telephony wiring practices.

14.1.3.2 Compatibility Considerations. All implementations of the twisted-pair link shall be compatible at the MDI. The MAU and the medium are defined to provide compatibility among devices designed by different manufacturers. Designers are free to implement circuitry within the MAU in an application-dependent manner provided the MDI and AUI (when implemented) specifications are met.

14.1.3.3 Mode of Operation. The 10BASE-T MAU is capable of operating in *normal* mode only (see 7.1.4). The MAU shall not operate in *monitor* mode.

When normal mode is in operation, the MAU functions as a direct connection between the medium and the DTE or repeater. Data from the DTE or repeater is output to one of the simplex link segments of the link segment, and data received on the other simplex link segment is input to the DTE or repeater.

14.1.4 Relationship to PLS and AUI. A close relationship exists between Section 14 and Section 7. Section 14 specifies the physical medium parameters and the PMA logical functions residing in the physical MAU. The MAU provides services to the PLS defined in Section 7 by means of the AUI. 10BASE-T MAUs support a subset of the AUI services specified in Section 7. 10BASE-T MAUs do not support the optional isolate function, the optional CO circuit, or the optional CS1 signal on the CI circuit.

The design of an external MAU component requires the use of both Section 14 and Section 7 for the PLS and AUI specifications.

The figures and numerous textual references throughout Section 14 refer to terminology associated with the AUI (that is, DO, DI, and CI). Since an embodiment of the 10BASE-T MAU does not require the implementation of an AUI, the DO, DI, and CI circuits may not physically exist. However, they are logically present and MAU operation is defined in terms of them.

14.2 MAU Functional Specifications. The MAU provides the means by which signals on the three AUI signal circuits to and from the DTE or repeater and their associated interlayer messages are coupled to the twisted-pair link segment. The MAU provides the following functional capabilities to handle message flow between the DTE or repeater and the twisted-pair link segment:

- (1) **Transmit function.** Provides the ability to transfer Manchester-encoded data from the DO circuit to the TD circuit. While not sending Manchester-encoded data on the TD circuit, the MAU sends an idle signal, TP_IDL, on the TD circuit.
- (2) **Receive function.** Provides the ability to transfer Manchester-encoded data from the RD circuit to the DI circuit. While not sending Manchester-encoded data on the DI circuit, the MAU sends an idle signal, IDL, on the DI circuit.
- (3) **Loopback function.** Provides the ability to transfer Manchester-encoded data from the DO to the DI circuit when the MAU is sending Manchester-encoded data to the TD circuit.
- (4) **Collision Presence function.** Provides the ability to detect simultaneous occurrence of Manchester-encoded data on the RD and DO circuits and to report such an occurrence as a collision.
- (5) **signal_quality_error Message (SQE) Test function.** Provides the ability to indicate to the DTE that the Collision Presence function is operational and that the *signal_quality_error* message can be sent by the MAU.
- (6) **Jabber function.** Provides the ability to prevent abnormally long reception of Manchester-encoded data on the DO circuit from indefinitely disrupting transmission on the network. While such a condition is present, transfer of Manchester-encoded data by the Transmit and Loopback functions is disabled.

- (7) **Link Integrity Test function.** Provides the ability to protect the network from the consequences of failure of the simplex link attached to the RD circuit. While such a failure is present, transfer of Manchester-encoded data by the Transmit, Receive, and Loopback functions is disabled.

14.2.1 MAU Functions. The MAU shall provide the Transmit, Receive, Loopback, Collision Presence, Jabber, and Link Integrity Test functions. The SQE Test function shall be performed by MAUs that are connected to DTEs and shall not be performed by MAUs that are connected to repeaters. A capability may be provided in the MAU to activate or inhibit the SQE Test function. It is not required that a MAU determine that it is connected to either a DTE or a repeater and automatically activate or inhibit the SQE Test function.

14.2.1.1 Transmit Function Requirements. The MAU shall receive the signals on the DO circuit and send them to the TD circuit of the MDI. A positive signal on the A lead relative to the B lead of the DO circuit shall result in a positive signal on the TD+ (Transmit Data +) lead of the MDI with respect to the TD- lead.

At the start of a packet transmission, no more than 2 bits may be received from the DO circuit and not transmitted on the TD circuit. In addition, it is permissible for the first bit sent to contain phase violations or invalid amplitude. All subsequent bits of the packet shall be reproduced with the differential voltage specified in 14.3.1.2.1 and with no more jitter than is specified in 14.3.1.2.3. The second bit transmitted on the TD circuit shall be transmitted with the correct timing and signal levels. The steady-state propagation delay between the DO circuit input and the TD circuit shall not exceed 2 BT.

For any two packets that are separated by 9.6 μ s or less, the start-up delay (bit loss plus steady-state propagation delay) of the first packet shall not exceed that of the second packet by more than 2 BT.

Whenever data is not being transmitted on the TD circuit, an idle signal, TP_IDL, shall be transmitted on the TD circuit. TP_IDL is a start of idle, as defined in 14.3.1.2.1, followed by a repeating sequence of a 16 ms \pm 8 ms period of silence (the time where the differential voltage remains at 0 mV \pm 50 mV) and a link test pulse (see 14.3.1.2.1). Following a packet and start of idle, the repeating sequence shall start with a period of silence.

Transmission of TP_IDL may be terminated at any time with respect to the link test pulse. It shall be terminated such that no more than the first transmitted bit of a packet is corrupted, and with no more delay than is specified for bit loss and steady-state propagation.

14.2.1.2 Receive Function Requirements. The MAU shall receive the signals on the RD circuit of the MDI and send them to the DI circuit. A positive signal on the RD+ (Receive Data +) lead relative to the RD- lead of the MDI shall result in a positive signal on the A lead with respect to the B lead of the DI circuit.

At the start of a packet reception from the RD circuit, no more than 5 bits may be received on the RD circuit and not transmitted onto the DI circuit. In addition, it is permissible for the first bit sent on the DI circuit to contain phase violations or invalid data; however, all successive bits of the packet shall be sent with no more than the amount of jitter specified in 14.3.1.3.1. The steady-state propagation delay between the RD circuit and the DI circuit shall not exceed 2 BT.

For any two packets that are separated by 9.6 μ s or less, the start-up delay of the first packet shall not exceed that of the second packet by more than 2 BT.

14.2.1.3 Loopback Function Requirements. When the MAU is transmitting on the TD circuit and is not receiving RD input messages (14.2.2.4) on the RD circuit, the MAU shall transmit on the DI circuit the signals received on the DO circuit in order to provide loopback of the transmitted signal. At the start of packet transmission on the TD circuit, no more than 5 bits of information may be received from the DO circuit and not transmitted to the DI circuit. In addition, it is permissible for the first bit sent on the DI circuit to contain phase violations or invalid data; however, all successive bits of the packet shall meet the jitter specified in 14.3.1.3.1 (that is, 13.5 ns plus 1.5 ns). The steady-state propagation delay between the DO circuit and the DI circuit shall not exceed 1 BT.

14.2.1.4 Collision Presence Function Requirements. The MAU shall detect as a collision the simultaneous occurrence of activity on the DO circuit and the RD circuit while in the Link Test Pass state. While a collision is detected, a CSO signal (see 7.3.1.2) shall be sent on the CI circuit. The signal shall be

presented to the CI circuit no more than 9 BT after the occurrence of a collision. The signal shall be deasserted within 9 BT after the DO circuit or the RD circuit changes from active to idle.

When CS0 is asserted on the CI circuit due to a collision, the data on the RD circuit shall be sent to the DI circuit within 9 BT.

When the RD circuit changes from active to idle and data is present on the DO circuit, the data on the DO circuit shall be sent to the DI circuit within 9 BT.

The signal presented on the CI circuit in the absence of collision, SQE test, or Jabber shall be the IDL signal.

14.2.1.5 signal_quality_error Message (SQE) Test Function Requirements. The SQE Test function shall be performed by MAUs that are connected to DTEs and shall not be performed by MAUs that are connected to repeaters. When the SQE test is performed, the MAU shall send CS0 on the CI circuit for a time 'SQE_test' beginning a time 'SQE_test_wait' after the last positive transition of a packet on the DO circuit. The value of 'SQE_test' shall be $10 \text{ BT} \pm 5 \text{ BT}$ and the value of 'SQE_test_wait' shall be between $0. \mu\text{s}$ and $1.6 \mu\text{s}$. This function should use as much of the normal collision detection and signaling circuitry as possible without introducing extraneous signals on the TD circuit or the DI circuit.

The CS0 signal shall not be sent by the SQE Test function while in any of the Link Test Fail states.

14.2.1.6 Jabber Function Requirements. The MAU shall contain a self-interrupt capability to prevent an illegally long transmission by a DTE from permanently disrupting transmission on the network and to disable loopback to the DI circuit (Fig 14-5). The MAU shall provide a window 'xmit_max' during which time the Transmit function may continuously transmit *TD_output* messages to the TD circuit. The value of 'xmit_max' shall be between 20 ms and 150 ms. If a transmission exceeds this duration, the Jabber function shall inhibit the Loopback function and the transmission of *TD_output* messages by the Transmit function, and shall send the CS0 signal on the CI circuit. This shall continue until *output_idle* has been continuously present on the DO circuit for a time 'unjab'. The value of 'unjab' shall be $0.5 \text{ ms} \pm 0.25 \text{ s}$.

It is permissible to activate the Jabber function when the TD circuit transmitter is sending *TD_output* messages for longer than 'xmit_max'.

The MAU shall not activate its Jabber function when the repeater's MAU Jabber Lockup Protection function operates at its longest permitted time as specified in 9.8.5.

14.2.1.7 Link Integrity Test Function Requirements. In order to protect the network from the consequences of a simplex link segment failure, the MAU shall monitor the RD circuit for *RD_input* and link test pulse activity. If neither *RD_input* nor a link test pulse is received for a time 'link_loss', the MAU shall enter the Link Test Fail state and cause the *input_idle* message to be sent on the DI circuit and the *TD_idle* message to be sent on the TD circuit (Fig 14-6). The value of 'link_loss' shall be between 50 ms and 150 ms. When *RD_input* or a number 'lc_max' of consecutive link test pulses is received on the RD circuit, the MAU shall exit the Link Test Fail state. The value of 'lc_max' shall be between 2 and 10 inclusive.

Only link test pulses that occur within time 'link_test_max' of each other shall be considered consecutive. The value of 'link_test_max' shall be between 25 ms and 150 ms. In addition, detected pulses that occur within a time 'link_test_min' of a previous pulse or packet shall be ignored while in the Link Test Pass state. In the Link Test Fail state, such pulses shall reset the counted number of consecutive link test pulses to zero. The value of 'link_test_min' shall be between 2 ms and 7 ms. Re-enabling shall be deferred until the signals on the RD and DO circuits become idle. The MAU shall not detect a link test pulse as *RD_input*. Additionally, a MAU may exit the Link Test Fail Extend state and enter the Link Test Pass state when the RD circuit becomes idle and the Jabber function has disabled transmission on the TD circuit.

While the MAU is not in the Link Test Pass state, the Link Integrity Test function shall disable the bit transfer of the Transmit, Receive, and Loopback functions, and the Collision Presence and SQE Test functions.

At PowerOn, in place of entering the Link Test Pass state as shown in Fig 14-6, a MAU may optionally enter the Link Test Fail Reset state.

If a visible indicator is provided on the MAU to indicate the link status, it is recommended that the color be green and that the indicator be labeled appropriately. It is further recommended that the indicator be on when the MAU is in the Link Test Pass state and off otherwise.

14.2.2 FMA Interface Messages. The messages between the PLS in the DTE and the FMA in the MAU shall comply with the FMA interface messages described in 7.2.1. These messages also are used in repeater

unit to PMA communication. These and the messages between the PMAs over the MDI are summarized below.

14.2.2.1 PLS to PMA Messages. The following messages are sent by the PLS in the DTE or repeater to the PMA in the MAU:

Message	Circuit	Signal	Meaning
<i>output</i>	DO	CD1,CD0	Output information
<i>output_idle</i>	DO	IDL	No data to be output

14.2.2.2 PMA to PLS Messages. The following messages are sent by the MAU to the PLS in the DTE or repeater:

Message	Circuit	Signal	Meaning
<i>input</i>	DI	CD1,CD0	Input information
<i>input_idle</i>	DI	IDL	No information to input
<i>mau_available</i>	CI	IDL	MAU is available for output
<i>signal_quality_error</i>	CI	CS0	Error detected by MAU

Retiming of CD1 and CD0 signals within the MAU is neither prohibited nor required. Considerable jitter may be present (see 14.3.1.3.1).

14.2.2.3 PMA to Twisted-Pair Link Segment Messages

Message	Circuit	Signal	Meaning
<i>TD_output</i>	TD	CD1,CD0	Output information
<i>TD_idle</i>	TD	TP_IDL	No information to output

The encoding for TP_IDL is defined in 14.2.1.1. The encoding for CD1 and CD0 is the same as that used on the AUI. Retiming of CD1 and CD0 signals within the MAU is neither prohibited nor required.

14.2.2.4 Twisted-Pair Link Segment to PMA Messages

Message	Circuit	Signal	Meaning
<i>RD_input</i>	RD	CD1,CD0	Input information
<i>RD_idle</i>	RD	TP_IDL	No information to input

The encoding for TP_IDL is defined in 14.2.1.1. The encoding for CD1 and CD0 is the same as that used on the AUI.

14.2.2.5 Interface Message Time References. Delay and bit loss specifications are measured from the occurrence of messages at the MDI and MAU AUI. The following describes the point where each message starts:

Message	Reference
<i>output</i>	leading bit cell boundary (BCB) of first valid CD1 or CD0
<i>output_idle</i>	last positive-going transition prior to start of IDL
<i>input</i>	leading BCB of first valid CD1 or CD0
<i>input_idle</i>	last positive-going transition prior to start of IDL
<i>signal_quality_error</i>	first transition of valid amplitude
<i>mau_available</i>	last positive-going transition prior to start of IDL
<i>TD_output</i>	leading BCB of first valid CD1 or CD0
<i>TD_idle</i>	last positive-going transition prior to start of TP_IDL
<i>RD_output</i>	leading BCB of first valid CD1 or CD0
<i>RD_idle</i>	last positive-going transition prior to start of TP_IDL

14.2.3 MAU State Diagrams. The state diagrams of Figs 14-3, 14-4, 14-5, and 14-6 depict the full set of allowed MAU state functions relative to the circuits of the AUI and MDI.

The notation used in the state diagrams follows the conventions in 1.2.1. The variables and timers used in the state diagrams are defined in the following sections.

14.2.3.1 State Diagram Variables. Variables are used in the state diagrams to indicate the status of MAU inputs and outputs, to control MAU operation, and to pass state information between functions.

In the variable definitions, the name of the variable is followed by a brief description of the variable and a list of values the variable may take. For those variables that are state diagram outputs, one value will be identified as the default. The variable has the default value when no active state contains a term assigning a different value.

For example, the variable *xmit* has the value *'disable'* whenever the Jabber function or the Link Integrity Test function is in a state that asserts *'xmit=disable'*. The variable has the default value *'enable'* all other times.

The variables used in the state diagrams are defined as follows:

- DI.** Controls the signal sent by the MAU on the DI circuit.
Values: *idle*; MAU is sending *input_idle*, IDL (default).
DO; MAU sends the signal received on the DO circuit.
lpbk = disable overrides this and causes *input_idle* to be sent.
RD; MAU sends the signal received on the RD circuit.
rcv = disable overrides this and causes *input_idle* to be sent.
- CI.** Controls the signal sent by the MAU on the CI circuit.
Values: *idle*; MAU sends *max_available*, IDL (default).
SQE; MAU sends *signal_quality_error*, CS0.
- DO.** Status of the signal received by the MAU on the DO circuit.
Values: *idle*; MAU is receiving *output_idle*, IDL.
active; MAU is receiving *output*, CD0 or CD1.
- TD.** Controls the signal sent by the MAU on the TD circuit.
Values: *idle*; MAU sends *TD_idle*, TP_IDL (default).
DO; MAU sends the signal received on the DO circuit.
xmit = disable overrides this and causes *TD_idle* to be sent.
- RD.** Status of the signal received by the MAU on the RD circuit.
Values: *idle*; MAU is receiving silence or a link test pulse.
active; MAU is detecting signals which meet the requirements of 14.3.1.3.2.
- link_test_rcv.** Status of the link test signal received by the MAU on the RD circuit.
Values: *false*; MAU is not detecting a link test pulse.
true; MAU is detecting a link test pulse.
- link_count.** Count of the number of consecutive link test pulses received while in the Link Fail state.
Values: non-negative integers.
- lc_max.** The number of consecutive link test pulses required before exit from the Link Fail state.
Values: positive integer between 2 and 10 inclusive.
- rcv.** Controls the path from the RD circuit to the DI circuit.
Values: *enable*; receive is enabled (default).
disable; the output to the DI circuit is *input_idle* when DI=RD.
- lpbk.** Controls the path from the DO circuit to the DI circuit.
Values: *enable*; loopback is enabled (default).
disable; the output to the DI circuit is *input_idle* when DI=DO.
- xmit.** Controls the path from the DO circuit to the TD circuit.
Values: *enable*; transmit is enabled (default).
disable; transmit is disabled and the signal sent on the TD circuit is TP_IDL.

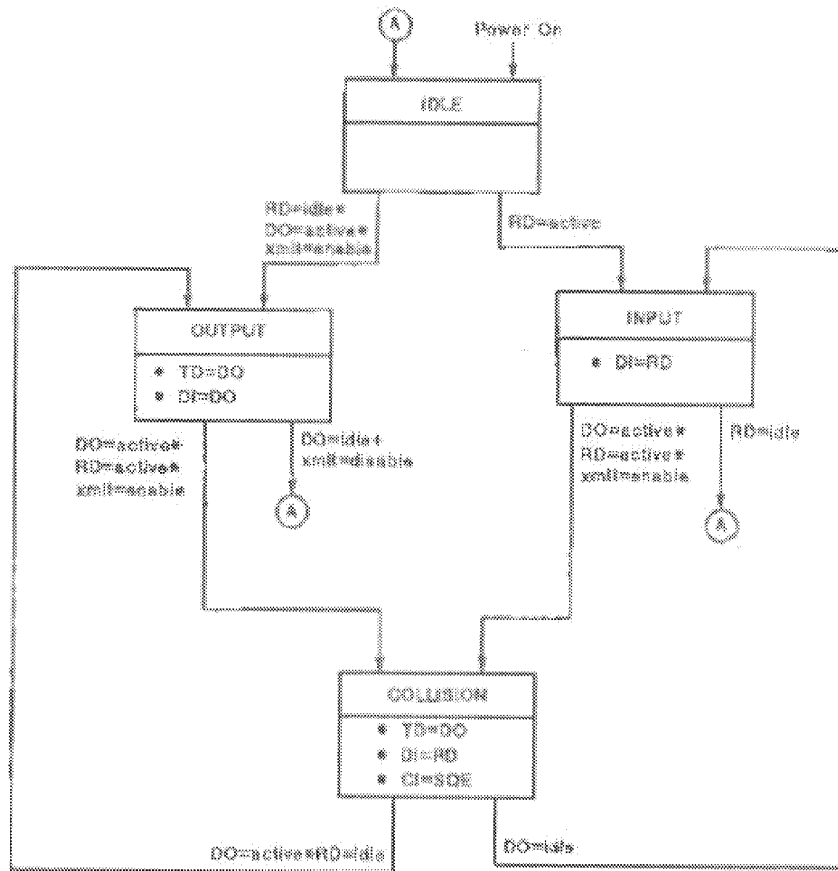

Fig 14-3
 MAU Transmit, Receive, Loopback, and Collision Presence Functions State Diagram

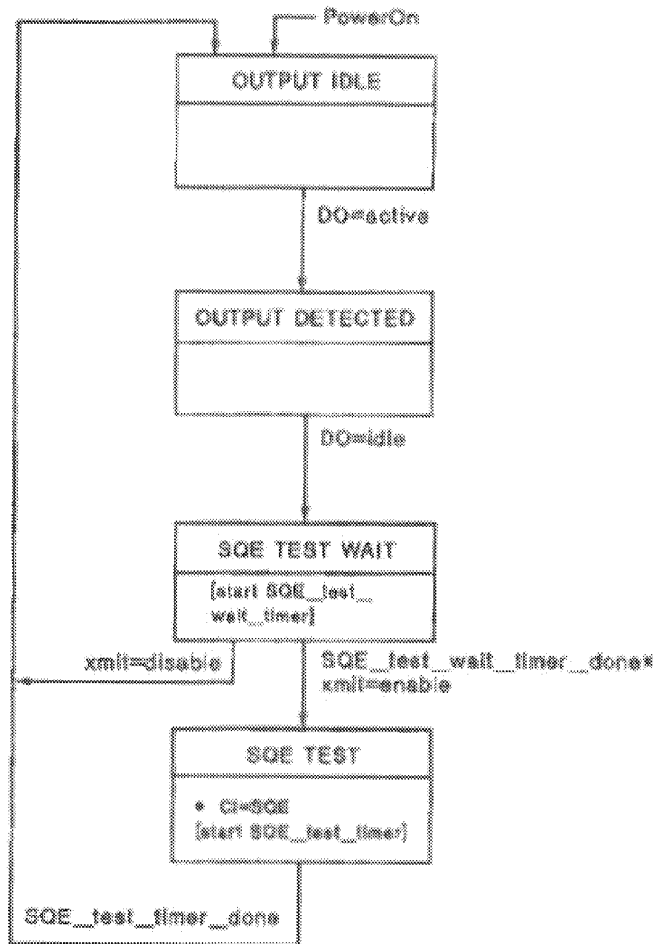

Fig 14-4
signal_quality_error Message Test Function State Diagram

14.2.3.2 State Diagram Timers. All timers operate in the same fashion. A timer is reset and starts counting upon entering a state where 'start x_timer' is asserted. Time 'x' after the timer has been started, 'x_timer_done' is asserted and remains asserted until the timer is reset. At all other times, 'x_timer_not_done' is asserted.

When entering a state where 'start x_timer' is asserted, the timer is reset and restarted even if the entered state is the same as the exited state; for example, when in the Link Test Pass state of the Link Integrity Test function state diagram, the 'link_loss_timer' and the 'link_test_min_timer' are reset each time the term 'RD = active + (link_test_rcv=true + link_test_min_timer_done)' is satisfied.

link_loss_timer. Timer for longest time input activity can be missing before the MAU determines that a link fail condition exists (14.2.1.7).

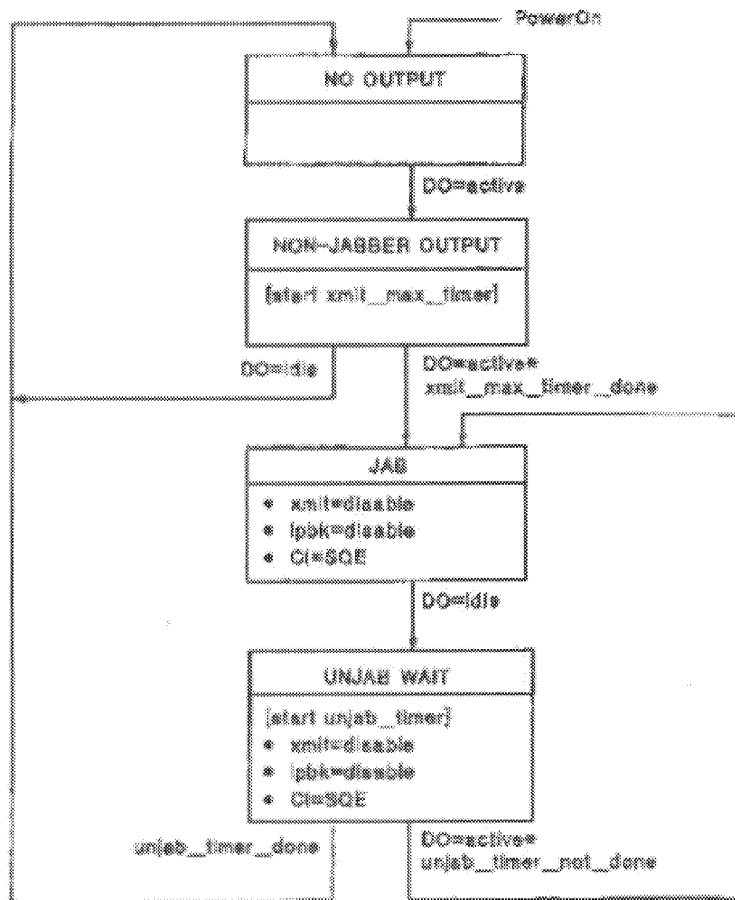

Fig 14-5
Jabber Function State Diagram

link_test_min_timer. Timer for the minimum time between valid link test pulses (14.2.1.7).

link_test_max_timer. Timer for maximum time input activity can be missing before Link Fail state is exited (14.2.1.7).

SQE_test_timer. Timer for the duration of the CS0 signal used for the SQE Test function (14.2.1.5).

SQE_test_wait_timer. Timer for the delay from end of packet to the start of the CS0 signal used for the SQE Test function (14.2.1.5).

xmit_max_timer. Timer for excessively long transmit time (14.2.1.6).

unjab_timer. Timer for the length of time the DO circuit must be continuously idle to allow transmission to be re-enabled (14.2.1.6).

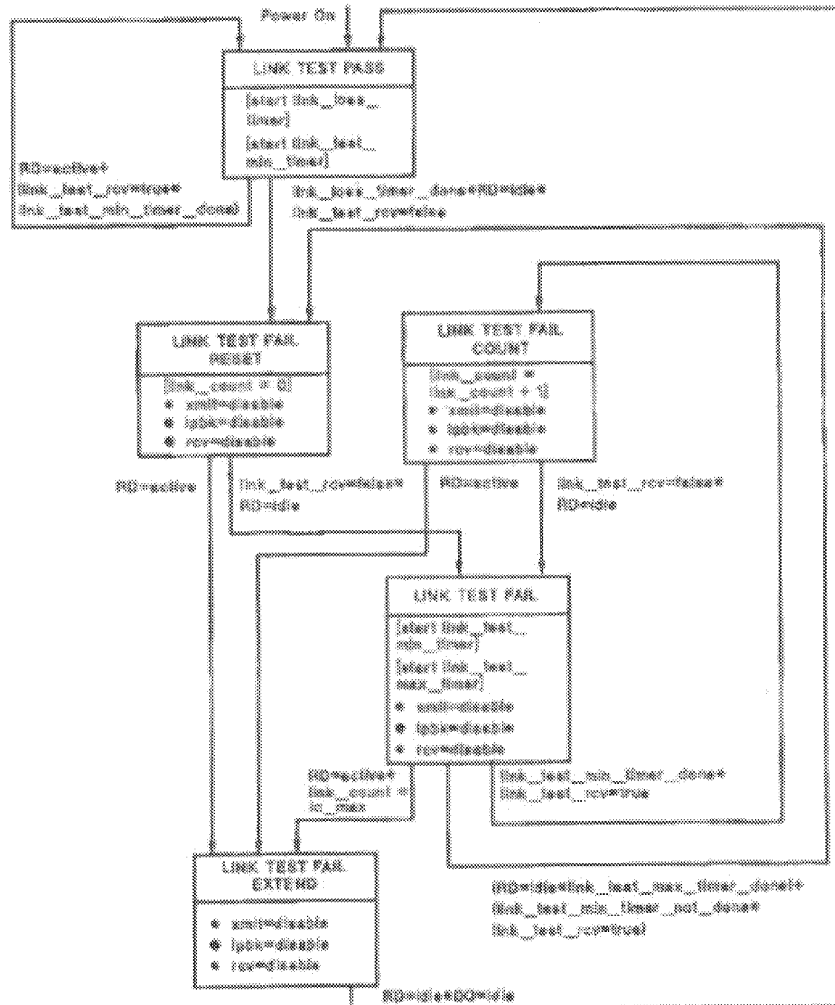

Fig 14-6
 Link Integrity Test Function State Diagram

14.3 MAU Electrical Specifications. This section defines the electrical characteristics of the MAU at the MDI and the AUI. The MAU shall also meet the AUI requirements specified in Section 7 when the AUI is implemented.

Additional information relative to conformance testing is given in A4.3.

The ground for all common-mode tests is circuit PG, Protective Ground of the AUI. In implementations without an AUI, chassis ground is used as circuit PG. All components in test circuits shall be ±1% unless otherwise stated.

14.3.1 MAU-to-MDI Interface Characteristics

14.3.1.1 Isolation Requirement. The MAU shall provide isolation between the DTE Physical Layer circuits including frame ground and all MDI leads including those not used by 10BASE-T. This electrical separation shall withstand at least one of the following electrical strength tests.

- (1) 1500 V rms at 50 Hz to 60 Hz for 60 s, applied as specified in Section 5.3.2 of IEC Publication 950 [8].
- (2) 2250 Vdc for 60 s, applied as specified in Section 5.3.2 of IEC Publication 950 [8].
- (3) A sequence of ten 2400 V impulses of alternating polarity, applied at intervals of not less than 1 s. The shape of the impulses shall be 1.2/50 μ s (1.2 μ s virtual front time, 50 μ s virtual time of half value), as defined in IEC Publication 60 [11].

There shall be no insulation breakdown, as defined in Section 5.3.2 of IEC Publication 950 [8], during the test. The resistance after the test shall be at least 2 M Ω , measured at 500 Vdc.

14.3.1.2 Transmitter Specifications. The MAU shall provide the Transmit function specified in 14.2.1.1 in accordance with the electrical specifications of this section.

Where a load is not specified, the transmitter shall meet requirements of this section when connected to a 100 Ω resistive load. The use of 100 Ω terminations simplifies the measurement process when using 50 Ω measurement equipment as 50 Ω to 100 Ω impedance matching transformers are readily available.

Some tests in this section require the use of an equivalent circuit that models the distortion introduced by a simplex link segment. This twisted-pair model shall be constructed according to Fig 14-7 with component tolerances as follows: Resistors, $\pm 1\%$; capacitors, $\pm 5\%$; inductors, $\pm 10\%$. Component tolerance specifications shall be met from 5.0 MHz to 15 MHz. For all measurements, the TD circuit shall be connected through a balun to Section 1 and the signal measured across a load connected to Section 4 of the model. The balun shall not affect the peak differential output voltage specified in 14.3.1.2.1 by more than 1% when inserted between the 100 Ω resistive load and the TD circuit.

The insertion loss of the twisted-pair model when measured with a 100 Ω source and 100 Ω load shall be between 9.70 dB and 10.45 dB at 10 MHz, and between 6.50 dB and 7.05 dB at 5 MHz.

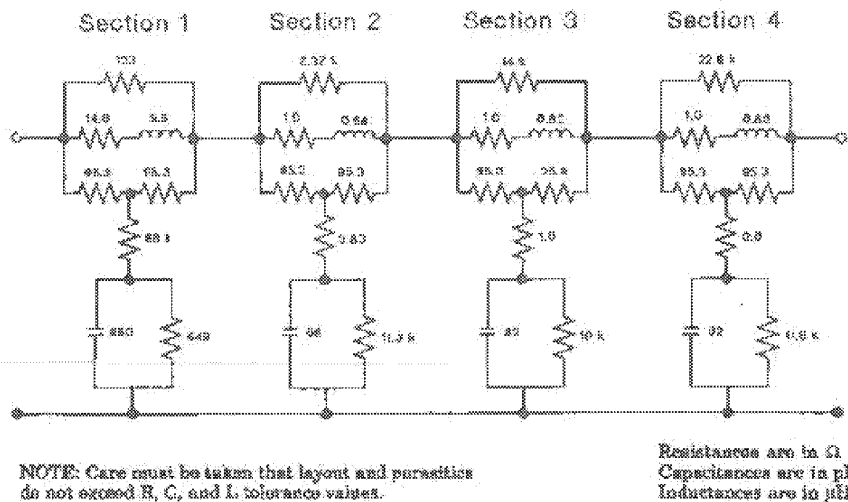

Fig 14-7
Twisted-Pair Model

14.3.1.2.1 Differential Output Voltage. Some of the text and figures of this section describe the differential voltage in terms of magnitudes. These requirements apply to negative as well as positive pulses.

The peak differential voltage on the TD circuit when terminated with a 100 Ω resistive load shall be between 2.2 V and 2.8 V for all data sequences. When the DO circuit is driven by an all-ones Manchester-encoded signal, any harmonic measured on the TD circuit shall be at least 27 dB below the fundamental.

NOTE: The specification on maximum spectral components is not intended to ensure compliance with regulations concerning RF emissions. The implementor should consider any applicable local, national, or international regulations. Additional filtering of spectral components may therefore be necessary.

The output signal V_o , is defined at the output of the twisted-pair model as shown in Fig 14-8. The TD transmitter shall provide equalization such that the output waveform shall fall within the template shown in Fig 14-9 for all data sequences. Voltage and time coordinates for inflection points on Fig 14-9 are given in Table 14-1. (Zero crossing points are different for external and internal MAUs. The zero crossings depicted in Fig 14-9 apply to an external MAU.) The template voltage may be scaled by a factor of 0.9 to 1.1 but any scaling below 0.9 or above 1.1 shall not be allowed. The recommended measurement procedure is described in A4.3.1. Time $t = 0$ on the template represents a zero crossing, with positive slope, of the output waveform. During this test the twisted-pair model shall be terminated in 100 Ω and driven by a transmitter with a Manchester-encoded pseudo-random sequence with a minimum repetition period of 511 bits.

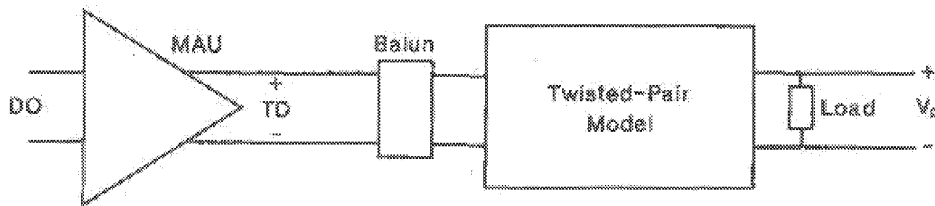

Fig 14-8
Differential Output Voltage Test

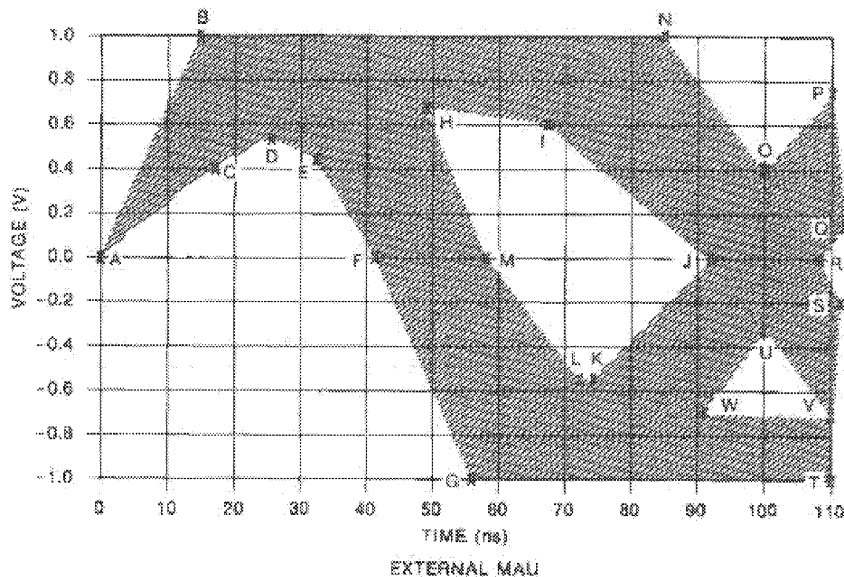

Fig 14-9
Voltage Template

Table 14-1
Voltage Template Values for Fig 14-8

Reference	Time (ns)		Voltage (V)
	External MAU	Internal MAU	
A	0	0	0
B	15	15	1.0
C	15	15	0.4
D	25	25	0.55
E	32	32	0.45
F	42	39	0
G	57	57	-1.0
H	48	48	0.7
I	67	67	0.6
J	92	89	0
K	74	74	-0.65
L	73	73	-0.65
M	98	91	0
N	86	85	1.0
O	100	100	0.4
P	110	110	0.75
Q	111	111	0.15
R	109	111	0
S	111	111	-0.15
T	110	110	-1.0
U	100	100	-0.3
V	110	110	-0.7
W	90	90	-0.7

This test shall be repeated with the template inverted about the time axis. In that case, $t = 0$ on the template represents a zero crossing, with negative slope, of the output waveform. When testing an external MAU the input waveform to the DO circuit of the MAU shall contribute no more than 0.5 ns of jitter. Adherence to this template does not verify that the requirements of 14.3.1.2.3 are met. (See A4.3.3 for modification of the template to test jitter.)

The TP_IDL shall always start with a positive waveform when a waveform conforming to Fig 7-12 is applied to the DO circuit. If the last bit transmitted was a CD1, the last transition will be at the bit cell center of the CD1. If the last bit transmitted was a CD0, the PLS will generate an additional transition at the bit cell boundary following the CD0. After the zero crossing of the last transition, the differential voltage shall remain within the shaded area of Fig 14-10. Once the differential voltage has gone more negative than -50 mV, it shall not exceed +50 mV. The template requirements of Fig 14-10 shall be met when measured across each of the test loads defined in Fig 14-11, both with the load connected directly to the TD circuit and with the load connected through the twisted-pair model as defined in Figs 14-7 and 14-8.

The link test pulse shall be a single positive (TD+ lead positive with respect to TD- lead) pulse, which falls within the shaded area of Fig 14-12. Once the differential output voltage has become more negative than -50 mV, it shall remain less than +50 mV. The template requirements of Fig 14-12 shall be met when measured across each of the test loads defined in Fig 14-11, both with the load connected directly to the TD circuit and with the load connected through the twisted-pair model as defined in Figs 14-7 and 14-8.

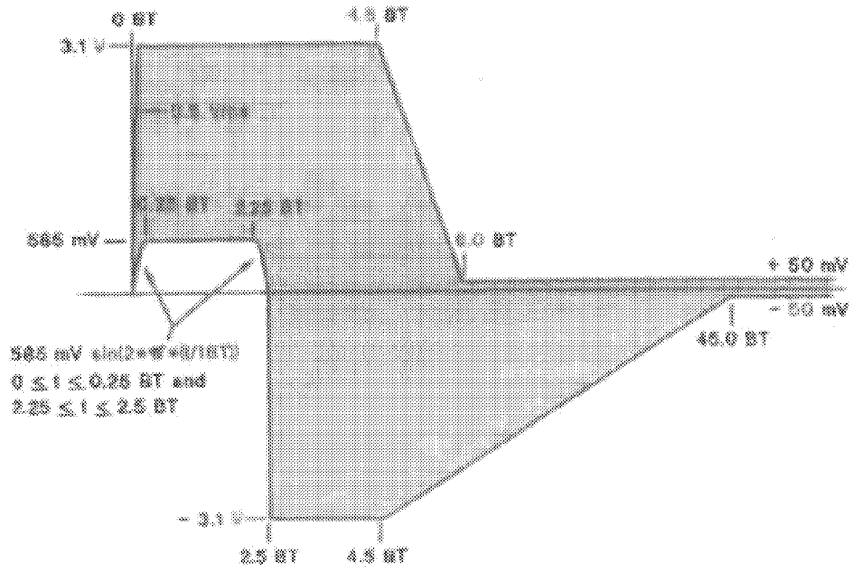
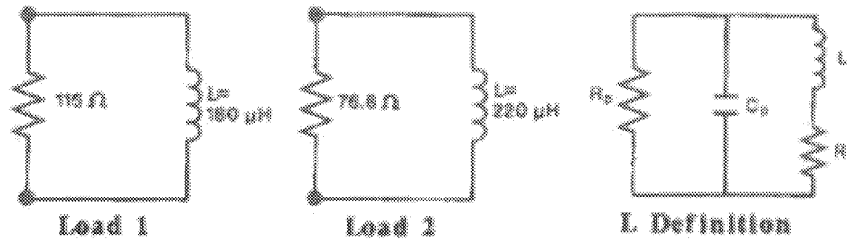

Fig 14-10
Transmitter Waveform for Start of TP_IDL



All parameters are defined over the frequency range of 250 kHz to 6 MHz.

$$L_p = L \pm 1\% \quad R_p \geq 2 \text{ k}\Omega$$

$$C_p = 12 \text{ pF} \pm 20\% \quad R_l < 0.5 \Omega$$

Fig 14-11
Start-of-TP_IDL Test Load

14.3.1.2.2 Transmitter Differential Output Impedance. The differential output impedance as measured on the TD circuit shall be such that any reflection, due to differential signals incident upon the TD circuit from a simplex link segment having any impedance within the range specified in 14.4.2.2, shall be at least 15 dB below the incident, over the frequency range of 5.0 MHz to 10 MHz. This return loss shall be maintained at all times when the MAU is powered, including when the TD circuit is sending TP_IDL.

14.3.1.2.3 Output Timing Jitter. The transmitter output jitter is measured at the output of the twisted-pair model terminated in a 100 Ω load, as shown in Fig 14-8. The jitter added to the signal on the DO circuit as it propagates through the MAU and the twisted-pair model shall be no more than ± 3.5 ns.

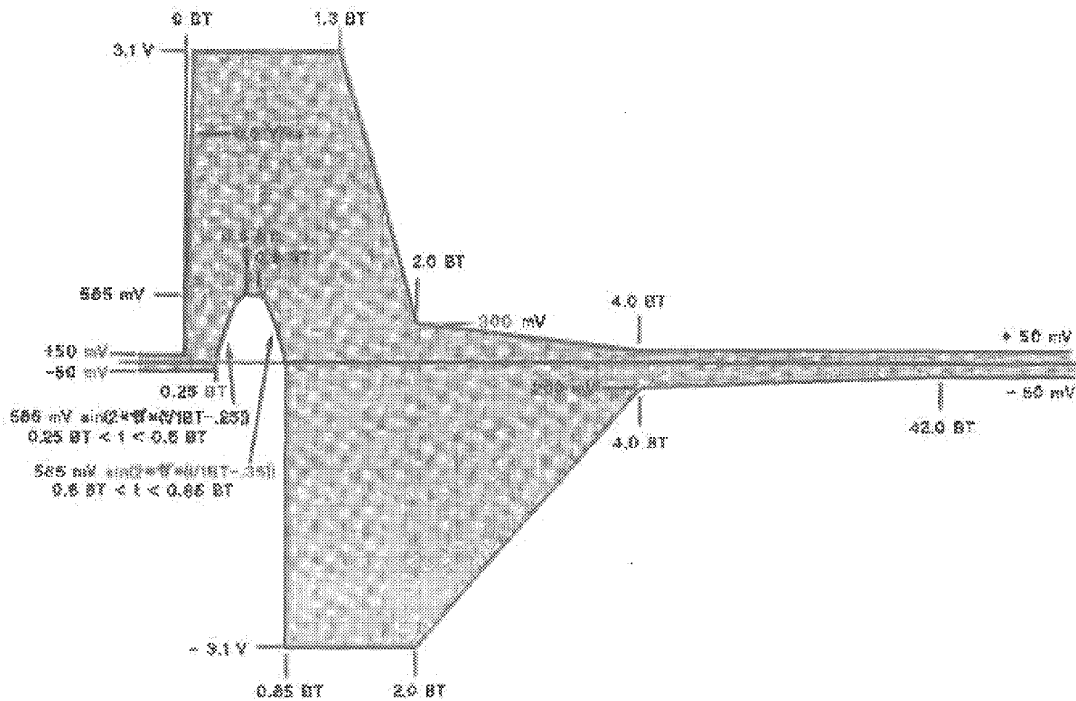

Fig 14-12
Transmitter Waveform for Link Test Pulse

Additionally, the MAU shall add no more than ± 8 ns of jitter to the signal received on the DO circuit when the TD circuit is directly driving a 100 Ω resistive load.

14.3.1.2.4 Transmitter Impedance Balance. The common-mode to differential-mode impedance balance of the TD circuit shall exceed $29 - 17 \log_{10}(f/10)$ dB (where f is the frequency in MHz) over the frequency range 1.0 MHz to 20 MHz. This balance is defined as $20 \log_{10}(E_{cm}/E_{diff})$, where E_{cm} is an externally applied sine wave voltage as shown in Fig 14-13.

NOTE: The balance of the test equipment (such as the matching of the 147 Ω resistors) must exceed that required of the transmitter.

14.3.1.2.5 Common-Mode Output Voltage. The magnitude of the total common-mode output voltage of the transmitter, E_{cm} , measured as shown in Fig 14-14, shall be less than 50 mV peak.

NOTE: This specification is not intended to ensure compliance with regulations concerning RF emissions. The implementer should consider any applicable local, national, or international regulations. Driving unshielded twisted pairs with high-frequency, common-mode voltages may result in interference to other equipment.

14.3.1.2.6 Transmitter Common-Mode Rejection. The application of E_{cm} , as shown in Fig 14-13, shall not change the differential voltage at the TD circuit, E_{diff} , by more than 100 mV for all data sequences. Additionally, the edge jitter added by the application of E_{cm} shall be no more than 1.0 ns. E_{cm} shall be a 15 V peak 10.1 MHz sine wave.

14.3.1.2.7 Transmitter Fault Tolerance. Transmitters, when either idle or non-idle, shall withstand without damage the application of short circuits across the TD circuit for an indefinite period of time and shall resume normal operation after such faults are removed. The magnitude of the current through such a short circuit shall not exceed 300 mA.

Transmitters, when either idle or non-idle, shall withstand without damage a 1000 V common-mode impulse applied at E_{cm} of either polarity (as indicated in Fig 14-15). The shape of the impulse shall be 0.3/50 μ s (300 ns virtual front time, 50 μ s virtual time of half value), as defined in IEC Publication 60 [11].

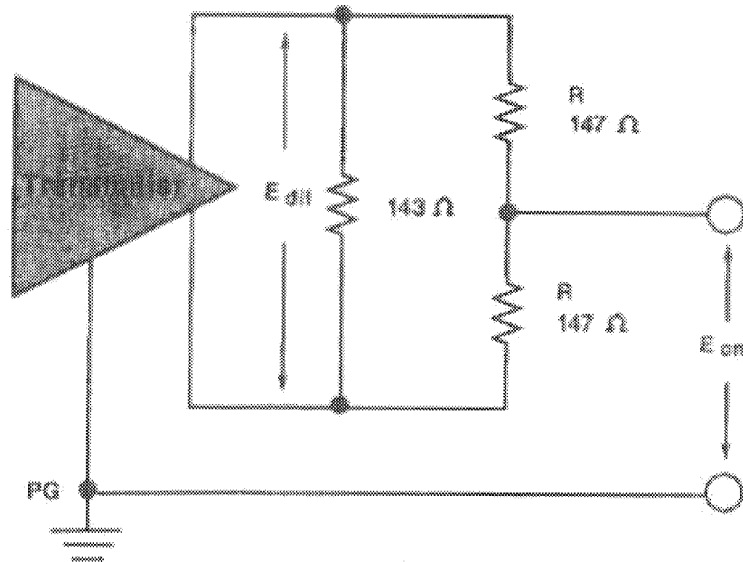

Fig 14-13
Transmitter Impedance Balance and Common-Mode Rejection Test Circuit

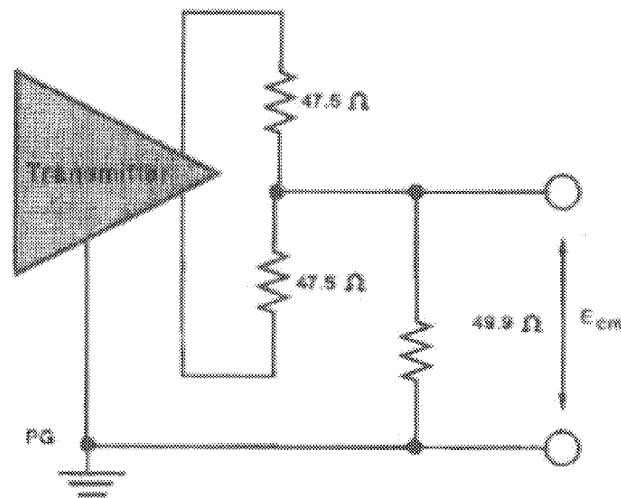

Fig 14-14
Common-Mode Output Voltage Test Circuit

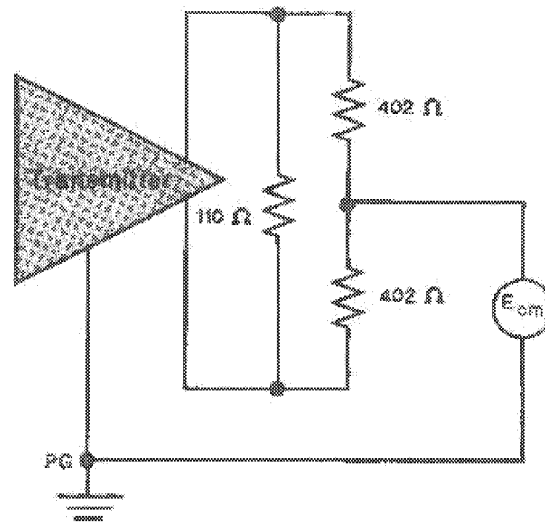

Fig 14-15
Transmitter Fault Tolerance Test Circuit

14.3.1.3 Receiver Specifications. The MAU shall provide the Receive function specified in 14.2.1.2 in accordance with the electrical specifications of this section.

14.3.1.3.1 Receiver Differential Input Signals. Differential signals received on the RD circuit that are within the envelope of Fig 14-16 and 14-17, and have a maximum zero crossing jitter up to ± 13.5 ns from the ideal shall be sent to the DI circuit. The 13.5 ns includes jitter caused by an encoder, AUI cable and transmitting MAU, the twisted pair, and noise. Additionally, the MAU receiver shall add no more than ± 1.5 ns jitter to the receive signal before sending the signal to the DI circuit.

14.3.1.3.2 Receiver Differential Noise Immunity. The receiver, when presented with Manchester-encoded data meeting the requirements of 14.3.1.3.1, shall send this data to the DI circuit with a bit loss of no more than that specified in 14.2.1.2. In addition, the receiver, when presented with a signal meeting the requirements of 14.2.1.1 and within the envelope of Fig 14-12, shall accept it as a link test pulse.

The receiver, while in the Idle state, shall reject as *RD input* the following signals:

- (1) All signals that when measured at the output of the following filter would produce a peak magnitude less than 300 mV. The filter is a 3-pole low-pass Butterworth with a 3 dB cutoff at 15 MHz (refer to A4.2).
- (2) All continuous sinusoidal signals of amplitude less than 6.2 V peak-to-peak and frequency less than 2 MHz.
- (3) All sine waves of single cycle duration, starting with phase 0 or 180 degrees, and of amplitude less than 6.2 V peak-to-peak where the frequency is between 2 MHz and 15 MHz. For a period of 4 BT before and after this single cycle, the signal shall be less than 300 mV when measured through the filter specified in (1) above.

14.3.1.3.3 Idle Input Behavior. The idle condition shall be detected within 2.3 BT of the last low-to-high transition at the receiver. The receiver shall take precautions to ensure that the high-to-silence transition of the start of idle is not falsely interpreted as a silence-to-non-idle transition, even in the presence of signal droop, overshoot, ringing, slow voltage decay, or a combination thereof due to capacitive and inductive effects in the transmitter, link segment, and receiver.

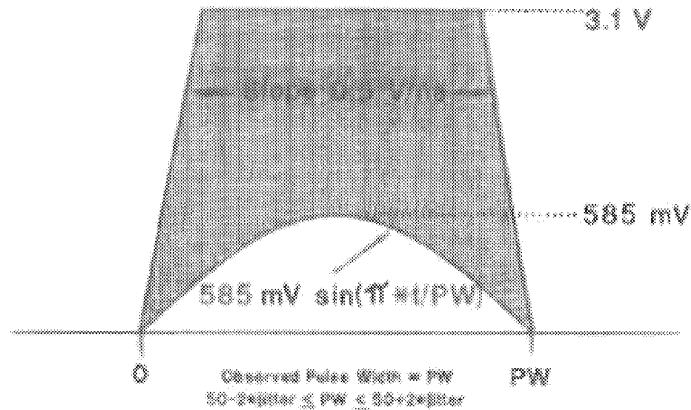

Fig 14-16
Receive Differential Input Voltage—Narrow Pulse

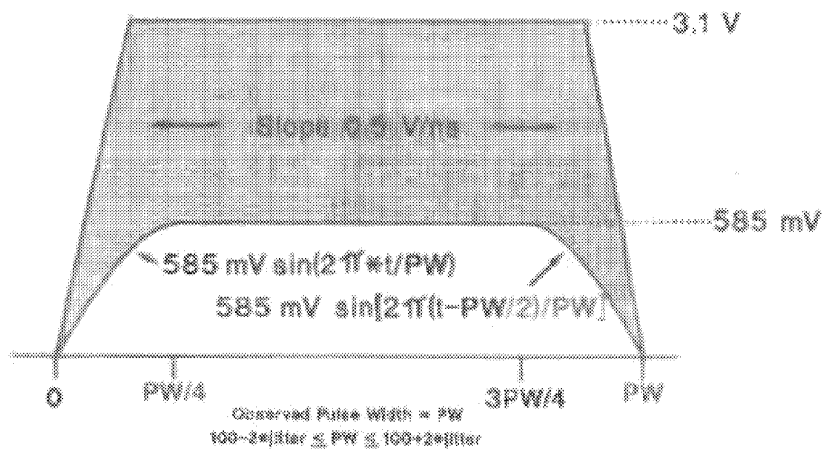

Fig 14-17
Receiver Differential Input Voltage—Wide Pulse

14.3.1.3.4 Receiver Differential Input Impedance. The differential input impedance shall be such that any reflection, due to differential signals incident upon the RD circuit from a twisted pair having any impedance within the range specified in 14.4.2.2 shall be at least 15 dB below the incident over the frequency range of 5.0 MHz to 10 MHz. The return loss shall be maintained when the MAU is powered.

14.3.1.3.5 Common-Mode Rejection. Receivers shall assume the proper state on DI for any differential input signal E_d that results in a signal E_{diff} that meets 14.3.1.3.1 even in the presence of common-mode voltages E_{cm} (applied as shown in Fig 14-16). E_{cm} shall be a 25 V peak-to-peak square wave, 500 kHz or lower in frequency, with edges no slower than 4 ns (20%-80%). Additionally, E_{cm} shall contribute no more than 2.5 ns of edge jitter to the signal transmitted on the DI circuit. The combination of the receiver timing jitter of 14.3.1.3.1 and the common-mode induced jitter are such that the MAU shall add no more than 4.0 ns of edge jitter to E_d before sending the signal on the DI circuit.

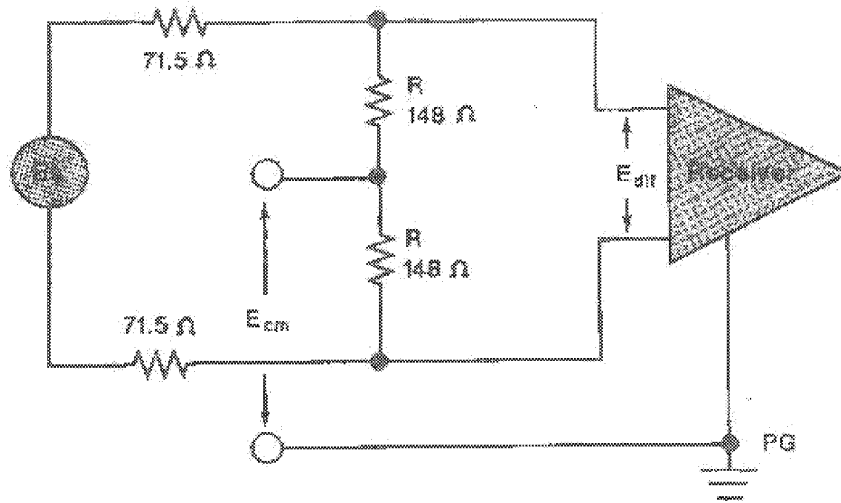

Fig 14-18
Receiver Common-Mode Rejection Test Circuit

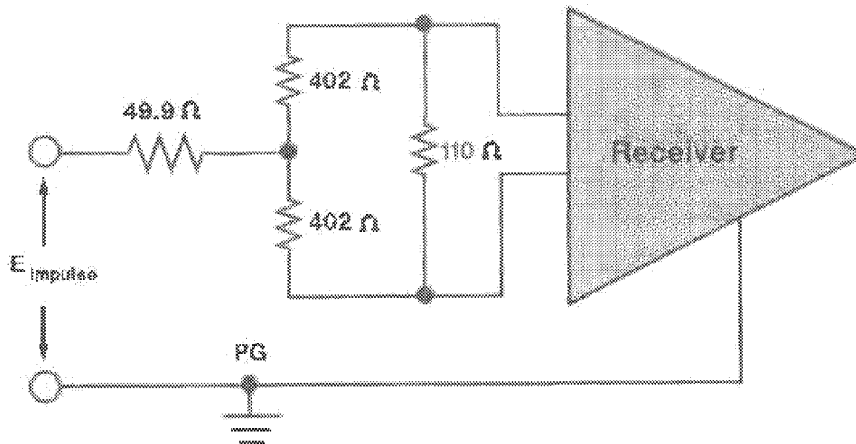

Fig 14-19
Common-Mode Impulse Test Circuit

14.3.1.3.6 Receiver Fault Tolerance. The receiver shall tolerate the application of short circuits between the leads of the RD circuit for an indefinite period of time without damage and shall resume normal operation after such faults are removed. Receivers shall withstand without damage a 1000 V common-mode impulse of either polarity ($E_{impulse}$ as indicated in Fig 14-19). The shape of the impulse shall be 0.3/60 μs (300 ns virtual front time, 50 μs virtual time of half value), as defined in IEC Publication 60 [11].

14.3.2 MAU-to-AUI Specification. When a MAU contains a physical AUI connector, the following specifications shall be met.

14.3.2.1 MAU-AUI Electrical Characteristics. The electrical characteristics for the driver and receiver components within the MAU that are connected to the AUI shall be identical to those specified in

7.4 and 7.5. Additionally, the AUI DO receiver, while in the Idle state, shall reject an input waveform of less than ± 160 mV differential.

14.3.2.2 MAU-AUI Mechanical Connection. The MAU shall be provided with a 15-pin male connector as specified in 7.6.

14.3.2.3 Power Consumption. Following PowerOn, the surge current drawn by the MAU shall be such that $I_p \times T_w$ is less than or equal to 2×10^{-4} ampere-seconds, where I_p is the peak surge current and T_w is the time during which the current exceeds the larger of 0.5 A or $0.5 \times I_p$. After the 100 ms following PowerOn, the current drawn by the MAU shall not exceed 0.5 A when powered by the AUI.

The MAU shall be capable of operating from all possible voltage sources, including those current limited to 0.5 A, as supplied by the DTE or repeater through the resistance of all permissible AUI cables.

The MAU shall not introduce extraneous signals on the TD, CI, or DI circuits during normal power-up and power-down.

14.4 Characteristics of the Simplex Link Segment. Except where otherwise stated, the simplex link segment shall be tested with source and load impedances of 100 Ω .

14.4.1 Overview. The medium for 10BASE-T is twisted-pair wiring. Since a significant number of 10BASE-T networks are expected to be installed utilizing in-place unshielded telephone wiring and typical telephony installation practices, the end-to-end path including different types of wiring, cable connectors, and cross connects must be considered. Typically, a DTE connects to a wall outlet using a twisted-pair patch cord. Wall outlets connect through building wiring and a cross connect to the repeater MAU in a wiring closet.

NOTE: EIA/TIA 568 (1991) [A19] provides specifications for media and installation practices suitable for use with this standard.

14.4.2 Transmission Parameters. Each simplex link segment shall have the following characteristics. All characteristics specified apply to the total simplex link segment unless otherwise noted. These characteristics are generally met by 100 m of unshielded twisted-pair cable composed of 0.5 mm [24 AWG] twisted pairs.

14.4.2.1 Insertion Loss. The insertion loss of a simplex link segment shall be no more than 11.5 dB at all frequencies between 5.0 and 10 MHz. This consists of the attenuation of the twisted pairs, connector losses, and reflection losses due to impedance mismatches between the various components of the simplex link segment. The insertion loss specification shall be met when the simplex link segment is terminated in source and load impedances that satisfy 14.3.1.2.2 and 14.3.1.3.4.

NOTE: Multipair PVC-insulated 0.5 mm [24 AWG] cable typically exhibits an attenuation of 8 dB to 10 dB/100 m at 20 °C. The loss of PVC-insulated cable exhibits significant temperature dependence. At temperatures greater than 40 °C, it may be necessary to use a less temperature-dependent cable, such as most plenum-rated cables.

14.4.2.2 Differential Characteristic Impedance. The magnitude of the differential characteristic impedance of a 3 m length of twisted pair used in a simplex link segment shall be between 85 Ω and 111 Ω for all frequencies between 5.0 MHz and 10 MHz. Since characteristic impedance tends to decrease with increasing frequency, the above requirement is generally implied by the condition that the magnitude of the characteristic impedance over the frequency band 1 MHz to 16 MHz is $100 \Omega \pm 15 \Omega$. Also, the magnitude of the input impedance averaged over the 5.0 MHz to 10 MHz frequency band of a simplex link segment terminated in 100 Ω shall be between 85 Ω and 111 Ω .

14.4.2.3 Medium Timing Jitter. Intersymbol interference and reflections due to impedance mismatches between tandem twisted pairs of a twisted-pair link segment and effects of connection devices can introduce jitter to the CD1 and CD0 signals received on the RD circuit. No more than ± 5.0 ns of jitter shall be introduced to a test signal by a simplex link segment. The test signal shall have a peak amplitude of 3.0 V and 10% to 90% rise and fall times of 12 ns. The content of the test signal shall be a Manchester-encoded pseudo-random sequence with a minimum repetition period of 511 bits.

NOTE: Branches off a twisted pair (often referred to as "bridged taps" or "stubs") will generally cause excessive jitter and so should be avoided.

14.4.2.4 Delay. The maximum propagation delay of twisted pair shall be 5.7 ns/m (minimum velocity of $0.585 \times c$). The maximum propagation delay of a link segment shall not exceed 1000 ns.

14.4.3 Coupling Parameters. To avoid excessive coupling of signals between twisted pairs of a twisted-pair cable, the crosstalk must be limited. Crosstalk loss is specified for the twisted pairs in a twisted-pair cable or twisted-pair cable binder group that are used as 10BASE-T twisted-pair links. Crosstalk loss is specified with the far ends of both the disturbed and the disturbing pairs and the near end of the disturbed pair terminated in 100 Ω . Drivers of disturbing pairs shall have a source impedance of 100 Ω .

14.4.3.1 Differential Near-End Crosstalk (NEXT) Loss. The NEXT loss between any two twisted pairs of a twisted-pair cable is dependent upon the geometry of the twisted-pair cable. Since the proximity of any two twisted pairs is influenced by the size of the twisted-pair cable, the NEXT loss is affected by twisted-pair cable size.

14.4.3.1.1 Twenty-Five-Pair Cable and Twenty-Five-Pair Binder Groups. The NEXT loss between any two twisted pairs in a twenty-five-pair twisted-pair cable or binder group used for 10BASE-T applications shall be at least $30 - 15 \log_{10}(f/10)$ dB (where f is the frequency in MHz) over the frequency range 5.0 MHz and 10 MHz.

14.4.3.1.2 Four-Pair Cable. The NEXT loss between any two twisted pairs in a four-pair twisted-pair cable used for 10BASE-T applications shall be at least $26 - 15 \log_{10}(f/10)$ dB (where f is the frequency in MHz) over the frequency range 5.0 MHz and 10 MHz.

14.4.3.1.3 Other Cables. The NEXT loss requirement for all other twisted-pair cables shall be the multiple-disturber NEXT loss of 14.4.3.2.

14.4.3.2 Multiple-Disturber NEXT (MDNEXT) Loss. When a twisted-pair cable or twisted-pair cable binder group contains twisted pairs from multiple 10BASE-T twisted-pair link segments, the multiple-disturber crosstalk loss is dependent upon the specific selection of disturbing and disturbed pairs. For each 10BASE-T receive pair, MDNEXT is measured by having the remaining near-end transmit pairs (excluding the transmit pair associated with the receive pair under test) driven with identical and synchronized sine wave signals. MDNEXT may then be determined from the signal level observed on the receive pair under test. By examining all pair combinations with a fixed number of disturbers, a cumulative distribution of MDNEXT is obtained at each frequency of interest. The one percentile of this cumulative distribution shall be at least $23 - 15 \log_{10}(f/10)$ (where f is the frequency in MHz) at 5.0 MHz, 7.5 MHz, and 10 MHz. When the number of possible combinations allowed by a cable is fewer than 100, the MDNEXT loss for all combinations shall be at least $23 - 15 \log_{10}(f/10)$ (where f is the frequency in MHz) at 5.0 MHz, 7.5 MHz, and 10 MHz. Refer to 12.7.3.2 and Appendix A3 for a tutorial and method for estimating the MDNEXT loss for a complete n -pair cable.

14.4.4 Noise Environment. The noise level on the link segments shall be such that the objective error rate is met. The noise environment consists generally of two primary contributors: crosstalk from other 10BASE-T circuits; and externally induced impulse noise, typically from telephone ringing and dialing signals, and other office and building equipment.

14.4.4.1 Impulse Noise. The average rate of occurrence of impulses greater than 264 mV shall be less than or equal to 0.2/s as measured at the output of the following specified filter. Following the start of any particular impulse that is counted, any additional impulse shall be ignored for a period of 1 μ s. The simplex link segment shall be terminated at the far end in 100 Ω . The filter is a 3-pole Butterworth low-pass with a 3 dB cutoff at 15 MHz (refer to A4.2).

NOTE: Typically, the impulse noise occurrence rate changes inversely by one decade for each 5 dB to 9 dB change in the threshold voltage. If a count rate of N counts/s is measured on a specific twisted pair and filter at the specified voltage threshold, the median noise margin is approximately $7 \log_{10}(0.2/N)$ dB. Impulse noise may be a burst phenomenon and should be measured over an extended period of time.

14.4.4.2 Crosstalk Noise. The level of crosstalk noise on a simplex link segment depends on the level of the disturbing signal(s) and the crosstalk loss between the pair(s) carrying the signal(s) and the dis-

turbed pair. With the maximum transmit level (14.3.1.2), the sinusoidal crosstalk loss (14.4.3.2), and multiple, random Manchester-encoded disturbers, the peak self-crosstalk noise levels as measured at the output of the following specified filter shall be less than or equal to 264 mV. The filter is a 3-pole Butterworth low-pass with a 3 dB cutoff at 15 MHz (refer to A4.2).

14.5 MDI Specification. This section defines the MDI for the twisted-pair link segment. The link topology requires a crossover function between PMAs. Implementation and location of this crossover is also defined in this section.

14.5.1 MDI Connectors. Eight-pin connectors meeting the requirements of Section 3 and Figures 1-5 of ISO 8877 [20] shall be used as the mechanical interface to the twisted-pair link segment. The plug connector shall be used on the twisted-pair link segment and the jack on the MAU. These connectors are depicted (for informational use only) in Figs 14-20 and 14-21. The following table shows the assignment of signals to connector contacts.

<u>CONTACT</u>	<u>MDI SIGNAL</u>
1	TD+
2	TD-
3	RD+
4	Not used by 10BASE-T
5	Not used by 10BASE-T
6	RD-
7	Not used by 10BASE-T
8	Not used by 10BASE-T

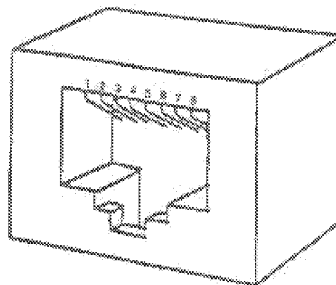

Fig 14-20
MAU MDI Connect

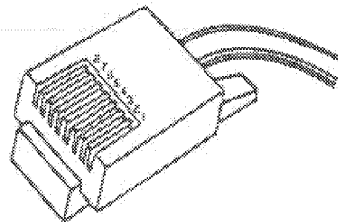
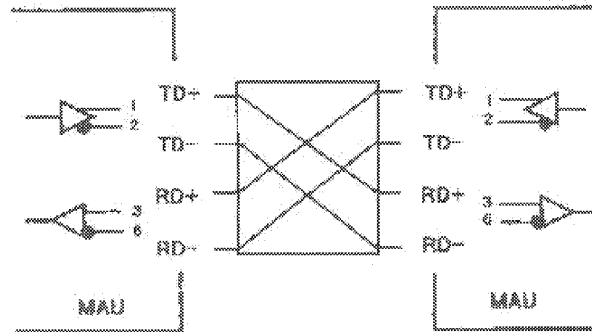
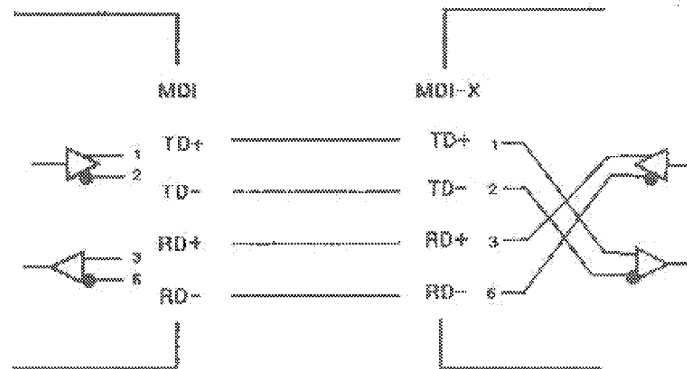

Fig 14-21
Twisted-Pair Link Segment Connector

14.5.2 Crossover Function. A crossover function shall be implemented in every twisted-pair link. The crossover function connects the transmitter of one MAU to the receiver of the MAU at the other end of the twisted-pair link. Crossover functions may be implemented internally to a MAU or elsewhere in the twisted-pair link. For MAUs that do not implement the crossover function, the signal names of 14.5.1 refer to their own internal circuits. For MAUs that do implement the crossover function, the signal names refer to the remote MAU of the twisted-pair link. Additionally, the MDI connector for a MAU that implements the crossover function shall be marked with the graphical symbol "X". Internal and external crossover functions are shown in Fig 14-22.



(a) External Crossover Function



(b) MAU-Embedded Crossover Function

Fig 14-22
Crossover Function

When a twisted-pair link connects a DTE to a repeater, it is recommended that the crossover be implemented in the MAU local to the repeater. If both MAUs of a twisted-pair link contain internal crossover functions, an additional external crossover is necessary. It is recommended that the crossover be visible to an installer from one of the MAUs. When both MAUs contain internal crossovers, it is further recommended in networks in which the topology identifies either a central backbone segment or a central hub that the MAU furthest from the central element be assigned the external crossover to maintain consistency.

Implicit implementation of the crossover function within a twisted-pair cable, or at a wiring panel, while not expressly forbidden, is beyond the scope of this standard.

14.6 System Considerations. The repeater unit specified in Section 9 forms the central unit for interconnecting 10BASE-T twisted-pair links in networks of more than two nodes. It also provides the means for connecting 10BASE-T twisted-pair links to other 10 Mb/s baseband segments. The proper operation of a CSMA/CD network requires network size to be limited to control round-trip propagation delay to meet the requirements of 4.2.3.2.3 and 4.4.2.1, and the number of repeaters between any two DTEs to be limited in order to limit the shrinkage of the interpacket gap as it travels through the network. Configuration rules, which ensure that these limits are not exceeded, are given in Section 13.

14.7 Environmental Specifications

14.7.1 General Safety. All equipment meeting this standard shall conform to one of the following IEC Publications: 380 [5], 435 [6], or 950 [8].

NOTE: For ISO/IEC 8802-3 : 1993, conformance shall be to IEC 569 [8].

14.7.2 Network Safety. This section sets forth a number of recommendations and guidelines related to safety concerns; the list is neither complete nor does it address all possible safety issues. The designer is urged to consult the relevant local, national, and international safety regulations to ensure compliance with the appropriate requirements.

LAN cable systems described in this section are subject to at least four direct electrical safety hazards during their installation and use. These hazards are as follows:

- (1) Direct contact between LAN components and power, lighting, or communications circuits.
- (2) Static charge buildup on LAN cables and components.
- (3) High-energy transients coupled onto the LAN cable system.
- (4) Voltage potential differences between safety grounds to which various LAN components are connected.

Such electrical safety hazards must be avoided or appropriately protected against for proper network installation and performance. In addition to provisions for proper handling of these conditions in an operational system, special measures must be taken to ensure that the intended safety features are not negated during installation of a new network or during modification or maintenance of an existing network. Isolation requirements are defined in 14.3.1.1.

14.7.2.1 Installation. Sound installation practice, as defined by applicable local codes and regulations, shall be followed in every instance in which such practice is applicable.

14.7.2.2 Grounding. Any safety grounding path for the MAU shall be provided through the circuit PG of the AUI connection.

WARNING: It is assumed that the equipment to which the MAU is attached is properly earthed, and not left floating nor serviced by a "doubly insulated ac power distribution system." The use of floating or insulated equipment, and the consequent implications for safety are beyond the scope of this standard.

14.7.2.3 Installation and Maintenance Guidelines. During installation and maintenance of the cable plant, care shall be taken to ensure that uninsulated network cable conductors do not make electrical contact with unintended conductors or ground.

14.7.2.4 Telephony Voltages. The use of building wiring brings with it the possibility of wiring errors that may connect telephony voltages to 10BASE-T equipment. Other than voice signals (which are low voltage), the primary voltages that may be encountered are the "battery" and ringing voltages. Although there is no universal standard, the following maximums generally apply.

Battery voltage to a telephone line is generally 56 Vdc applied to the line through a balanced 400 Ω source impedance.

Ring voltage is a composite signal consisting of an ac component and a dc component. The ac component is up to 175 V peak at 20 Hz to 60 Hz with a 100 Ω source resistance. The dc component is 56 Vdc with a 300 Ω to 600 Ω source resistance. Large reactive transients can occur at the start and end of each ring interval.

Although 10BASE-T equipment is not required to survive such wiring hazards without damage, application of any of the above voltages shall not result in any safety hazard.

NOTE: Wiring errors may impose telephony voltages differentially across 10BASE-T transmitters or receivers. Because the termination resistance likely to be present across a receiver's input is of substantially lower impedance than an off-hook telephone instrument, receivers will generally appear to the telephone system as off-hook telephones. Therefore, full-ring voltages will be applied for only short periods. Transmitters that are coupled using transformers will similarly appear like off-hook telephones (though perhaps a bit more slowly) due to the low resistance of the transformer coil.

14.7.3 Environment

14.7.3.1 Electromagnetic Emission. The twisted-pair link shall comply with applicable local and national codes for the limitation of electromagnetic interference.

14.7.3.2 Temperature and Humidity. The twisted-pair link is expected to operate over a reasonable range of environmental conditions related to temperature, humidity, and physical handling (such as shock and vibration). Specific requirements and values for these parameters are considered to be beyond the scope of this standard.

It is recommended that manufacturers indicate in the literature associated with the MAU the operating environmental conditions to facilitate selection, installation, and maintenance.

It is recommended that manufacturers indicate, in the literature associated with the components of the twisted-pair link segment, the distance and operating environmental conditions over which the specifications of 14.4 will be met.

14.8 MAU Labeling. It is recommended that each MAU (and supporting documentation) be labeled in a manner visible to the user with at least these parameters:

- (1) Data rate capability in Mb/s,
- (2) Power level in terms of maximum current drain (for external MAUs),
- (3) Any applicable safety warnings.

See also 14.5.2.

14.9 Timing Summary. Table 14-2 summarizes the timing requirements for the 10BASE-T twisted-pair link. This table is a summary; for complete descriptions of the timing requirements, refer to the referenced sections.

Table 14-2
Maximum Timing Parameters

Symbol	Function	Bit Loss [†]	Invalid Bits [†]	Steady-State Propagation Delay [†]	Start-up Delay [†]		Specified in
					Maximum	Variability [‡]	
M1	<i>RD_input</i> to <i>input</i> on DI	5.0	1.0	2.0	8.0	2.0	14.2.1.2
M2	<i>output</i> on DO to <i>TD_output</i>	2.0	1.0	2.0	5.0	2.0	14.2.1.1
M3	<i>RD_input</i> * <i>output</i> to <i>signal_quality_error</i>	—	—	—	8.0	—	14.2.1.4
M4	<i>RD_idle</i> + <i>output_idle</i> (end of collision) to <i>max_available</i>	—	—	—	8.0	—	14.2.1.4
M5	<i>RD_input</i> * <i>output</i> to <i>input</i> on DI from circuit RD	—	—	—	8.0	—	14.2.1.4
M6	<i>RD_idle</i> * <i>output</i> to <i>input</i> on DI from circuit DO	—	—	—	8.0	—	14.2.1.4
M7	<i>output_idle</i> on DO to <i>signal_quality_error</i>	—	—	—	0 < x < 10	—	14.2.1.5
M8	<i>signal_quality_error</i> duration for SQE test	—	—	—	5 < x < 15	—	14.2.1.5
M9	<i>output</i> on DO to <i>input</i> on DI	5.0	1.0	1.0	7.0	—	14.2.1.3
T1	twisted-pair propagation	0	0	10.00	10.00	—	14.4.2.4
A1	AUI cable propagation (30 m)	0	0	2.57	2.57	—	7.4.2.7

[†]All Times in BT.

[‡]For an explanation of the meaning of variability, see 14.2.1.1 and 14.2.1.2.

Annex Additional Reference Material

(This Annex is not a part of this International Standard but is a part of ANSI/IEEE Std 882.3, 1993.)

- [A1] ANSI/EIA 364A-1987, Standard Test Procedures for Low-Frequency (Below 3 MHz) Electrical Connector Test Procedure.¹⁴
- [A2] ANSI/IEEE Std 770X3.97-1983, IEEE Standard Pascal Computer Programming Language.¹⁵
- [A3] Material from this reference is now incorporated into the base standard.
- [A4] Material from this reference is now incorporated into the base standard.
- [A5] ANSI/NFPA 70-1987, National Electrical Code.¹⁶
- [A6] ANSI/UL 94-1985, Tests for Flammability of Plastic Materials for Parts in Devices and Appliances.¹⁷
- [A7] ANSI/UL 114-1982, Safety Standard for Office Appliances and Business Equipment.
- [A8] ANSI/UL 478-1979, Safety Standard for Electronic Data-Processing Units and Systems.
- [A9] ECMA-97 (1985), Local Area Networks Safety Requirements.¹⁸
- [A10] EIA CB8-1981, Components Bulletin (Cat 4) List of Approved Agencies, US and Other Countries, Impacting Electronic Components and Equipment.
- [A11] FCC Docket 20780-1980 (Part 15), Technical Standards for Computing Equipment, Amendment of Part 15 to redefine and clarify the rules governing restricted radiation devices and low-power communication devices, Reconsidered First Report and Order, April 1980.¹⁹
- [A12] MIL-C-17F-1983, General Specification for Cables, Radio Frequency, Flexible and Semirigid.²⁰
- [A13] MIL-C-24308D-1983, General Specifications for Connector, Electric, Rectangular, Miniature Polarized Shell, Rack and Panel.
- [A14] UL Subject No 758: UL VW-1, Description of Appliance Wiring Material.²¹
- [A15] AMP, Inc., Departmental Publication 5525, Design Guide to Coaxial Taps, Harrisburg, PA 17105.
- [A16] AMP, Inc., Instruction Sheet 6814, Active Tap Installation, Harrisburg, PA 17105.

¹⁴All ANSI publications are available from the Sales Department, American National Standards Institute, 11 West 42nd Street, New York, NY 10036, USA; EIA publications are available from the Standards Sales Department, Electronic Industries Association, 1001 Eye Street, NW, Washington, DC 20000, USA.

¹⁵IEEE publications are available from the Service Center, Institute of Electrical and Electronics Engineers, 445 Hoes Lane, P.O. Box 1331, Piscataway, NJ 08859-1331, USA.

¹⁶NFPA publications are available from Publications Sales, National Fire Protection Association, Batterymarch Park, Quincy, MA 02269-9101, USA.

¹⁷UL publications are available from Publications Sales, Underwriters Laboratories, Inc., 333 Pfingsten Rd., Northbrook, IL 60062, USA.

¹⁸ECMA publications are available from European Computer Manufacturers Association, 114 Rue du Rhone, 1204 Geneva, Switzerland.

¹⁹FCC publications are available from the Federal Communications Commission, Washington, DC 20542, USA.

²⁰MIL publications are available from US Navy Publications and Forms Center, 5801 Tabor Avenue, Philadelphia, PA 19126, USA.

²¹Information on this subject is available from Underwriters Laboratories, Inc., 1286 Walt Whitman Road, Melville, NY 11747, USA.

[A17] Brinch Hansen, P. *The Architecture of Concurrent Programs*. Englewood Cliffs, NJ: Prentice Hall, 1977.

[A18] Hammond, J.L., Brown, J.E., and Liu, S.S. *Development of a Transmission Error Model and Error Control Model*. Technical Report RADC/TR-76-138. Rome: Air Development Center (1976).

[A19] EIA/TIA 568 (1991), *Commercial Building Wiring Standard*.

Appendixes

(These Appendixes are not a part of this International Standard or of ANSI/IEEE Std 802.3, 1998 Edition.)

Appendix A System Guidelines

A1. Baseband System Guidelines and Concepts

A1.1 Overall System Objectives. The CSMA/CD Access Method, supported by baseband technology, depends on a variety of analog system components at and below the physical level of the OSI Reference Model. These components provide basic interconnection facilities for the CSMA/CD access mechanism itself and are defined throughout Sections 6, 7, and 8.

Overall performance of the analog baseband medium and related physical layer capabilities depends on an optimal and known set of analog capabilities within each of these critical system elements: the coaxial trunk cable, MAUs, branch cables, DTEs, and repeater units. These system elements affect the integrity with which the serial data bit stream analog signals are carried between open systems. There are at least three critical parameters of interest: bits lost in the transmission system, signal delays, and phase jitter. It is important that these be apportioned properly among the affected system elements.

The successful interconnection of multivendor system components mandates that the values for bits lost, signal delays, and phase jitter be allocated fairly and realistically among the various system elements. The balance of Appendix A identifies the upper limits of values to be placed on the subject parameters. These values are based on the maximal system configuration (for example, four repeater units, 2.5 km trunk coaxial cable medium).

A1.2 Analog System Components and Parameter Values. The values given in the following table are in terms of bits and are stated as maximum values except for values given within ranges.

The initial mnemonic under each component entry refers to the system component as identified in Fig A1. System parameters are stated in terms of the intralayer or interlayer messages sent within a station. Specific delays are called out as = delay.

The repeater concepts described throughout this section are considered to be an acceptable set of specifications for a multirepeated system. It is noted that the exact parametric values specified for the repeater environment are subject to minor refinement.

Component and Parameter	Start Up Delay	Lost In to Lost Out Delay	Start Up Loss
MEDIUM			
Trunk Coaxial Cable			
C1 Propagation	0.0	21.65	0.0
POINT TO POINT LINK			
P1 Propagation	0.0	25.54	0.0
A1 Propagation	0.0	2.57	0.0
MEDIUM ACCESS UNIT			
M1 DATA IN ASSERT → INPUT	6.0	0.5	5.0
M2 OUTPUT → DATA OUT ASSERT	3.0	0.5	2.0
M3 DATA IN COLLISION → SQE ASSERT	17.0	—	—
M4 COLLISION DEASSERT → SQE DEASSERT	20.0	—	—
M5 OUTPUT IDLE → SQE ASSERT	6 < x < 15	—	—
M6 SQE TEST ASSERT → SQE DEASSERT	5 ≤ x ≤ 15	—	—

Component and Parameter	Start Up Delay	Last In to Last Out Delay	Start Up Loss
DTE			
D1 INPUT → INPUT UNIT	18.0	---	18.0
D2 OUTPUT UNIT → OUTPUT	---	3.0	---
D3 INPUT → CARRIER STATUS = CARRIERS ON	3.0	---	---
D4 INPUT IDLE → CARRIER STATUS = OFF	$3.0 < x \leq 6.0$	---	---
D5 SQE ASSERT → CARRIER STATUS = ON	3.0	---	---
D6 SQE DEASSERT → CARRIER STATUS = OFF	$3.0 < x \leq 6.0$	---	---
D7 SQE ASSERT → SIGNAL STATUS = ERROR	3.0	---	---
D8 SQE DEASSERT → SIGNAL STATUS = NO ERROR	$3.0 < x \leq 6.0$	---	---
D9 CARRIER STATUS = OFF → OUTPUT UNIT	$96 \leq x \leq 100$	---	---
D10 INPUT → OUTPUT	8.0	---	---
D11 SIGNAL STATUS = ERROR → JAM OUTPUT	16.0	---	---
D12 JAM OUTPUT DURATION	=32.0	---	---
REPEATER UNIT			
R1 INPUT 1,2 → OUTPUT 2,1	7.5	---	$22 < x < 34$
R2 INPUT IDLE 1,2 → OUTPUT IDLE 2,1	---	12.5	---
R3 INPUT 1,2 → CARRIER STATUS = ON	3.0	---	---
R4 SQE → SOURCED OUTPUT	6.5	---	---
R5 JAM OUTPUT → OUTPUT IDLE	=96.0	---	---

Figure A1 indicates the maximal system configuration and identifies the various system component parameters considered critical in determining analog system performance.

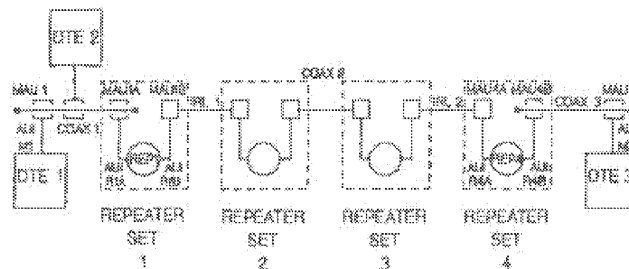

Fig A1
Maximal System Configuration Bit Budget Apportionments

A1.3 Minimum Frame Length Determination. The following table indicates the system elements that make up the minimum frame length calculation based on the worst-case numbers as outlined in the bit budget of A1.2. The compilation in the following table is based on the following scenario:

- (1) DTE 1 transmits to an adjacent DTE 2 on coaxial segment 1.
- (2) DTE 3 transmission collides with DTE 1 transmission.
- (3) DTE 3 is assumed to be the worst-case distance from DTE 1 and its transmission just misses deferring to the DTE 1 message.
- (4) The collision fragment travels back down the network to inform DTE 1 that a collision has occurred on its message.

The frame length is constrained by two parameters:

- (a) The message from DTE 1 shall be long enough so that it is still sending when the collision is detected.
- (b) The message from DTE 1 shall be short enough such that DTE 2 can throw out the message on the basis of being too short.

Component and Function	Direction	Table Entry	Delay	Total Delay
DTE 1 STARTS TO PUT OUT FIRST BIT				
DTE 1	FWD	D2	3.0	3.0
AUI M1	FWD	A1	2.57	5.57
MAU1	FWD	M2	3.0	8.6
COAX1	FWD	C1	21.65	30.2
REPEATER SET 1				
MAU 1A	FWD	M1	3.0	36.2
AUI 1A	FWD	A1	2.57	38.8
REP 1	FWD	R1	7.5	46.3
AUI 1B	FWD	A1	2.57	48.9
MAU 1B	FWD	M2	3.0	51.9
REPEATER SET TOTAL			21.64	
IRL 1	FWD	P1	25.04	77.5
REPEATER SET 2	FWD		21.6	99.1
COAX 2	FWD	C1	21.65	120.8
REPEATER SET 3	FWD		21.0	141.8
IRL 2	FWD	P1	25.04	166.9
REPEATER SET 4	FWD		21.0	187.9
COAX 3	FWD	C1	21.65	209.5
MAU 3	FWD	M1	6.0	215.5
AUI 3	FWD	A1	2.57	218.1
DTE 2 PUTS OUT A BIT	REV	D10	3.0	221.1
AUI 3	REV	A1	2.57	223.7
MAU 3	REV	M2	3.0	226.7
COAX 3	REV	C1	21.65	248.3
REPEATER SET 4				
MAU 4B	REV	M3	17.0	265.3
AUI 4B	REV	A1	2.57	267.9
REP 4	REV	R4	6.9	274.8
AUI 4A	REV	A1	2.57	277.4
MAU 4A	REV	M2	3.0	280.4
REPEATER SET TOTAL			31.64	
IRL 2	REV	P1	25.04	312.4
REPEATER SET 3	REV		21.64	334.1
COAX 2	REV	C1	21.65	355.7
REPEATER 3	REV		21.04	376.7
IRL 1	REV	P1	25.04	401.8
REPEATER SET 1	REV		21.64	423.4
COAX 1	REV	C1	21.65	445.1
MAU 1	REV	M3	17.0	462.1
AUI M1	REV	A1	2.57	464.7
DTE 1	REV	D7	3.0	467.7

The above table provides the scenario that enables DTE 1 to determine a collision is taking place. DTE 1 shall transmit for at least 489 bit times. To determine how much longer DTE 2 will continue to receive bits, assume that DTE 1 is the last transmitter to provide bits to the DTE 2 MAU. DTE 2 then sees the following:

Component and Function	Direction	Table Entry	Delay	Total Delay
DTE 1	FWD	D11	18.0	514.9
DTE 1	FWD	D12	32.0	546.9
AUI M1	FWD	A1	2.57	549.4

If Repeater Set 1 is the last system component to provide bits to DTE 2, then DTE 2 will see the following:

Component and Function	Direction	Table Entry	Delay	Total Delay
REPEATER SET 1 (1st JAM BIT)				
REP 1	REV	R5	68.0	454.6
COAX 1	REV	C1	21.86	572.3

The Repeater Set is the last transmitter to provide a bit to DTE 2. The DTE 2 MAU starts seeing bits at time 8.6, which means that DTE 2 sees 563.7 bits ($572.3 - 8.6$). DTE 2 sees a minimum of 61 preamble bits and 8 SFD bits. The preamble and SFD bits can be deleted from the 563.7 total because they are not counted in minimum frame length.

The minimum frame length determination from the above scenario is then $564.7 - 69.0 = 494.7$ bits. The 10 Mb/s system value for minimum frame length has been set at 512 bits.

A1.4 System Jitter Budgets. The typical jitter budget expected for the baseband system is apportioned in the following manner:

Encoder	0.5 ns
AUI Cable	1.3 ns (transmit end)
MAU Transmit	2.0 ns
Trunk Coax	7.5 ns
MAU Receive	-1.0 ns (with compensation)
AUI Cable	1.0 ns (receive end)
SNR on COAX	0.0 ns (SNR = 5:1)
SNR on AUI	0.5 ns (SNR = 5:1, transmit end)
SNR on AUI	0.5 ns (SNR = 5:1, receive end)
	16.5 ns

The 18 ns jitter budget leaves adequate design margin for implementation-dependent considerations.

A1.4.1 Nominal Jitter Values. The jitter budget values given above are not expected to accommodate all step changes in phase jitter due to system parameter variations within one or a few bit times.

A1.4.2 Decoder Evaluation. The phase decoder in the PLS sublayer should correctly decode a Manchester-encoded signal whose data transition point (center of a bit cell) has a peak-to-peak jitter of no more than 36 ns (± 18 ns deviation from the bit cell center). See Figs A2 and A3 for test method.

Evaluation of decoder performance may be simulated and tested by application of three distinct waveforms representing worst-case and normal conditions. The waveforms contain Manchester-encoded bits whose center transitions represent the extremes of maximum skew. A 5 MHz (repetition rate) pulse train whose pulse width is either 64 ns or 136 ns simulates the two worst-case jitter conditions. The data output from the decoder should remain stable for each of the three test patterns and shifts between these extremes where there is a low rate of change in center transition skew. Note that the actual transmission system is not expected to permit sudden drastic changes in the steady-state edge deviation during the reception of any given frame. The above evaluation process is not intended to guarantee proper decoder performance under all operating conditions.

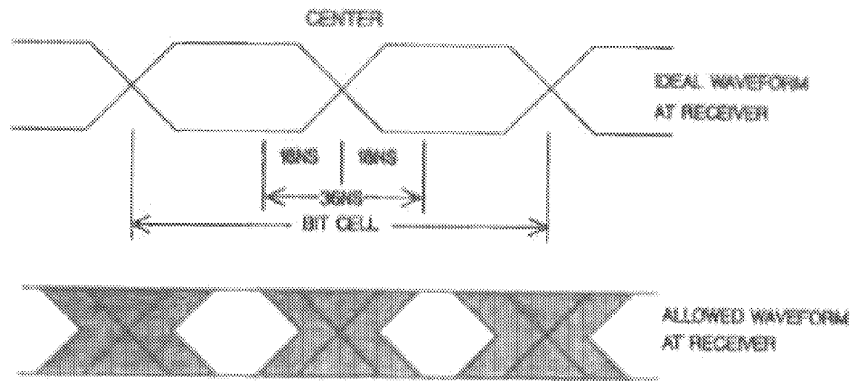

Fig A2
Typical Signal Waveforms

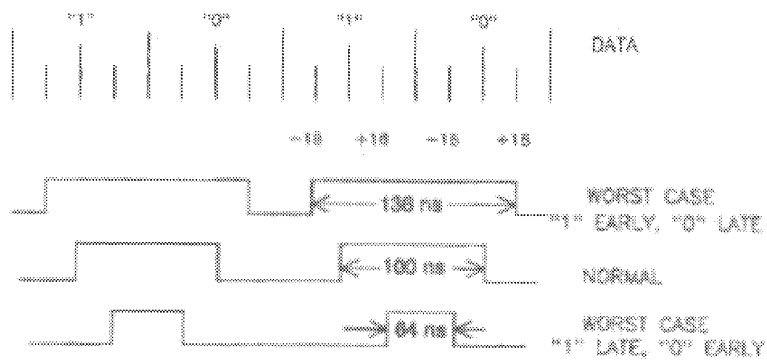

Fig A3
Worst-Case Signal Waveform Variations

A2. System Parameters and Budgets for 1BASE5

A2.1 Delay Budget. The successful interconnection of multivendor system components mandates that the values for bits lost and signal delays be allocated fairly and realistically among the various system elements. The following table summarizes and indicates the derivation of some of the delays specified in 12.9. The breakdowns shown for the parameters are illustrative only; implementors are free to make other allocations of delay *within* a device so long as the specifications of 12.9 are not violated.

Component	Delay (BT)
DTE Initial Transmit Delay (see 12.9.2)	3
DTE Deference Delay (see 12.9.2)	21
unsquelch	3
Carrier detect	5
MAC detects carrier and defers	10
DTE Initial Transmit Delay	3
DTE Collision Shutdown Delay (see 12.9.2)	58
detect CP and report SIGNAL_ERROR	10
detect SIGNAL_ERROR and start jamming	16
jamSize	32
Medium Transit Delay (see 12.9.3)	4
Special Link Transit Delay (see 12.9.4)	15
Hub Startup Delay (see 12.9.5)	12
unsquelch	4
half fill FIFO	6
analogue of DTE Initial Transmit Delay	3
Hub Idle Collision Startup Delay (see 12.9.5) (same as Hub Startup Delay)	12
Hub Transit Delay (see 12.9.5)	9
half fill FIFO	6
analogue of DTE Initial Transmit Delay	3
Hub Delay Stretch/Shrink (see 12.9.5) $((\text{preamble} + \langle \text{cfill} \rangle + \text{maxFrameSize}) \cdot 0.01\% \cdot 2)$	3
Hub Collision Detect Delay (see 12.9.5)	21
unsquelch	3
detect collision	6
Hub Transit Delay	9
First CVL or CVH may be preceded by CD0s and CD1s	3
Hub Active Collision Startup Delay (see 12.9.5)	12
Hub Transit Delay	9
First CVL or CVH may be preceded by CD0s and CD1s	3

Component	Delay (RT)
Hub Collision Shutdown Delay (downward) (see 12.9.5) (same as Hub Transit Delay)	0
Hub Collision Shutdown Delay (upward) (see 12.9.5)	25
detect loss of carrier	20
clear FIFO, if necessary	2
analogue of DTE Initial Transmit Delay	3

A2.2 Minimum Frame Length Determination. The minimum frame length for IBASES is determined using the values specified in 4.4.2.2 and 12.9, applied to the following (worst) case:

- (1) DTE 1, connected to Hub 1 at a network extremity, transmits a message upward toward Hub 5.
- (2) There is a special link in the path between Hub 1 and Hub 5.
- (3) DTE 2, also connected to Hub 1, transmits, just missing deferring to the downward signal from DTE 1 that was wrapped around at Hub 5.
- (4) DTE 3, also connected to Hub 1, receives the transmission from DTE 1.
- (5) Hub 1 generates CP, which travels up and then back down the network to inform DTE 1 and DTE 2 that a collision has occurred on their messages.
- (6) DTE 1 and DTE 2 continue to transmit until they have received CP, reacted to it, and completed their jams.
- (7) DTE 3 continues to receive until the end of CP.

The minimum frame length must allow both of the following conditions to be met:

- (1) DTE 1 is still sending when CP is received and recognized.
- (2) DTE 3 can discard the message fragment it receives because it is too short.

Event	Bits	Total
DTE 1 → DTE 2		
DTE Initial Transmit Delay	3	3
5 · Medium Transit Delay	32	35
2 · Special Link Transit Delay	30	65
10 · Hub Startup Delay	120	185
DTE Deference Delay	21	206
DTE 2 → HUB 1 CP		
Medium Transit Delay	4	210
Hub Collision Detect Delay	21	231
HUB 1 CP → HUB 5 CP		
3 · Medium Transit Delay	12	243
Special Link Transit Delay	15	358
4 · max(Hub Startup Delay, Hub Active Collision Startup Delay, Hub Idle Collision Startup Delay)	48	306
HUB 5 CP → DTE 1 receives CP		
5 · Hub Active Collision Startup Delay	60	366
4 · Medium Transit Delay	16	382
Special Link Transit Delay	15	397
DTE 1 receives CP → DTE 1 stops transmitting		
DTE Collision Shutdown Delay	58	455

COMPUTATION OF MINIMUM FRAME SIZE	-64	391 =
original preamble + <sfd>		data bits
		transmitted
5 · (Hub Collision Shutdown Delay (upward)		
-Hub Transit Delay)	80	471
5 · (Hub Collision Shutdown Delay (downward)		
-Hub Transit Delay)	0	471
Tiny fraction of Hub Delay Stretch/Shrink	0	471 =
		data bits received

The minimum frame length must exceed both the maximum number of bits sent before recognizing CP (391 - jamsize = 359) and the maximum collision fragment size (471), as computed above. The IEEE802.3 system value for minimum frame length has been set at 512 bits, which exceeds both of these values with a margin for error.

A2.3 Jitter Budget. The total edge jitter of the signals on each link must be limited to allow proper decoding at the receiver. The following budget has been used to allocate jitter to the indicated components that contribute to the total jitter on each link:

Component	Jitter
Transmitter skew	±10 ns
Cable intersymbol interference	9
Cable reflections	8
Reflections due to receiver termination mismatch	5
Total	±32 ns

The cable intersymbol interference and reflection allowances form the basis for the limit specified in 12.7.2.3; the reflection component is sufficient to allow a single 20 Ω impedance mismatch anywhere along a cable segment. The receiver-mismatch allowance is derived from the reflection attenuation specified in 12.5.3.2.4. The total forms the basis for the specification in 12.5.3.2.2.

The remainder of the jitter that can be tolerated by the Manchester decoder in a receiver is reserved to allow for distortion of the signal due to noise, receiver threshold offset, receiver skew, and receiver sampling timing error.

A simple clocked receiver/decoder with an 8 MHz sampling rate (the worst case allowed for in the design of this standard), can achieve proper decoding with up to ± 125 ns of jitter between two edges, which is equivalent to ±62.5 ns on each edge. Other receiver designs may tolerate more edge jitter. For example, a 6 MHz sampling rate would allow up to ±83.33 ns of jitter on each edge and a 16 MHz sampling rate allows up to ±31.25 ns of jitter.

It may be necessary to use a low-pass filter as part of the receiver to reduce the noise level seen by that receiver (see 12.7.4 for a description of the noise environment). A filter that reduces the noise may also have an effect on the amplitude and edge rate of the received signal. The filtered signal's edge rate near the zero-crossing is used in the critical translation from mV of noise and receiver offset into ns of jitter.

An example receiver design using an 8 MHz sampling rate and a 2 MHz Butterworth input filter might be based on the following jitter budget:

Component	Jitter
Input jitter (from above)	±32 ns
Noise and receiver threshold offset	19.5
Receiver skew (analog)	4
Receiver skew (digital)	7
Total	±62.5 ns

The two primary contributors to noise in a 1BASE5 cable are self-crosstalk and impulse noise (see 12.7.4). Because it is unlikely that both will be present at their 1% worst-case levels on any particular cable, the required bit error rate attributable to each source can be set at half of the one in 10^6 error rate required by 12.5.3.2.6.

Crosstalk noise is specified to be no more than 105 mV (peak) through a 2 MHz filter (see 12.7.4.2). Because crosstalk is present for the entire transmission of a packet, some crosstalk will coincide with the most sensitive part of the received signal. Therefore, the receiver must operate without error in the presence of this 105 mV of noise.

Impulse noise has a peak amplitude of 170 mV for ≤ 0.005 counts/s through the 2 MHz filter (see 12.7.4.1). This threshold does not directly correlate to jitter, however, because the derivation of the 62.5 ns jitter tolerance for an 8 MHz clock assumed worst-case sampling error. Assuming a random phasing of the sampling clock to the received signals, it can be shown that the 170 mV of noise is equivalent to a level of 85 mV with a worst-phase clock.

Jitter due to noise should be computed using the larger of the above two levels. The 105 mV for crosstalk noise, therefore, should be added to 50 mV for receiver threshold offset and the result should be divided by the edge rate of the filtered signal near the zero-crossing (7.9 mV/ns for the 2 MHz filter), yielding the 19.5 ns indicated above.

A3. Example Crosstalk Computation for Multiple Disturbers

A method for computing multiple-disturber, near end, crosstalk attenuation (MDNEXT) into each 1BASE5 pair is specified in 12.7.3.2. This appendix provides example computations of MDNEXT using that method when only the distribution of X_j is known.

The single-disturber probability distribution curve (labelled "1") shown in Fig A4 is based on actual measurement of 25-pair, 24-gauge, unshielded, twisted pair cable. The remaining probability distribution curves (labelled with the number of disturbing pairs) were computed using Monte Carlo simulation. To compute each sample MDNEXT_j for N disturbers, N values of crosstalk attenuation (X_j) were chosen from the single-disturber distribution and N values of crosstalk phase (θ_j) were chosen from a uniform distribution between 0 and 2π rad. These values were then used with the following equations to compute MDNEXT_j:

$$H_j = \sum_{1 \leq i \leq N} 10^{(-X_j/20)} \cos \theta_i$$

$$V_j = \sum_{1 \leq i \leq N} 10^{(-X_j/20)} \sin \theta_i$$

$$\text{MDNEXT}_j = 10 \log_{10} (H_j^2 + V_j^2)$$

Iterating this process several hundred times, each time producing a single MDNEXT_j sample, resulted in distributions for MDNEXT that are summarized in the following table and Fig A4:

Disturbers	Iterations	MDNEXT Mean	Std. Dev.	99%
1		61.2 dB	7.0 dB	48.6 dB
2	500	57.2	6.2	46.4
3	500	55.1	5.8	45.2
6	500	52.0	5.7	42.5
13	1000	48.5	5.4	39.1
18	500	47.1	5.3	37.8
24	500	45.9	5.9	36.2

Because two pairs are used for each 1BASE5 connection, the entries in this table for 18 and 24 disturbers are not applicable for normal installation of 25-pair cables. Furthermore, telephone cables with larger

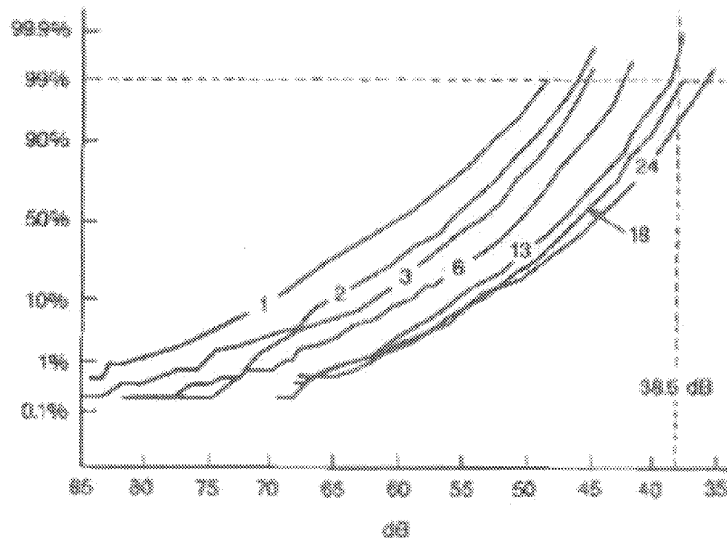

Fig A4
 MDNEXT Cumulative Probability Distribution

numbers of pairs are often constructed using sub-bundles of 25 pairs each and so might yield similar results (for example, the curves for 13 or fewer disturbers would be the most applicable ones).

The calculation method of this Appendix, though not the numeric values, applies to 10BASE-T.

A4. 10BASE-T

A4.1 System Jitter Budget. The jitter budget for 10BASE-T is apportioned as follows:

Jitter budget	Maximum Length Twisted-Pair Link	Short Length Twisted-Pair Link
(Jitter expressed in ns)		
Encoder	0.5	0.5
AUI cable (including SNR (D) pair)	1.5	1.5
MAU transmitter	2.0	2.0
Twisted-pair medium with equalization	1.5	6.0
Noise jitter on twisted-pair medium	8.0	2.0
MAU receiver	1.5	1.5
AUI cable (including SNR (E) pair)	1.5	1.5
Total	16.5	18.5

NOTE: Total transmit jitter for the combination of the MAU transmitter and link segment (A4.2.1.2.3) is 13.5 ns and 18.0 ns for maximum- and short-length twisted-pair link segments, respectively. It is the sum of the entries for MAU transmitter and twisted-pair medium with equalization. The individual components cannot be easily observed on MAU's. Short-length segment is defined as a short, non-severe-length twisted-pair link. A short- rather than a severe-length segment is used in the calculation since a severe-length segment will have no significant noise and is a less severe case.

A4.2 Filter Characteristics. The implementation of the 3-pole, low-pass Butterworth filter should have the following characteristics:

3 dB cutoff frequency	15 MHz
Insertion loss (5 MHz to 10 MHz)	≤1.0 dB
30 MHz attenuation	≥17.5 dB
Input impedance (5 MHz to 10 MHz)	100 Ω
Return loss with 100 Ω load (5 MHz to 10 MHz)	≥20 dB

This filter is only used for the tests described in 14.3.1.3.2, 14.4.4.1, and 14.4.4.2. A buffer may be needed to achieve the above return loss when using an LC implementation of this filter.

A4.3 Notes for Conformance Testing. The following notes are provided to assist in developing the conformance test.

A4.3.1 Notes for 14.3.1.2.1 on Differential Output Voltage. For testing harmonics measured on the TD circuit when the DO circuit is driven by an all-ones Manchester-encoded signal, it is acceptable to use a pattern of maximum length packets whose data field is all ones.

For testing of the maximum and minimum output signal to the template in Fig 14-9, the recommended measurement procedure is described as follows. An oscilloscope set for a zero voltage trigger with a positive slope is allowed to accumulate an eye pattern that must be within the template. Acquisition must be long enough to ensure that all data variations have been observed. When using packetized data, the TP_IDLE and the first transmitted bit should be excluded from this measurement. Also, the interpacket interval may be adjusted so that transition-to-idle transient effects are excluded. When testing with the inverted template, the slope of the scope trigger should be negative.

A4.3.2 Note for 14.3.1.2.2 on Transmitter Differential Output Impedance. The return loss (RL) is defined as follows:

$$RL = 20 \log_{10} \frac{|Z_{\text{transmitter}} + Z_{\text{cable}}|}{|Z_{\text{transmitter}} - Z_{\text{cable}}|}$$

and also

$$RL = 20 \log_{10} \frac{|V_i|}{|V_r|}$$

where

$Z_{\text{transmitter}}$ is the impedance of the transmitter

Z_{cable} is the impedance of the cable

V_i is the differential voltage incident upon the transmitter

V_r is the differential voltage reflected from the transmitter

- (1) A transmitter with a purely resistive source impedance of $96 \Omega \pm 20\%$ will satisfy this requirement.
- (2) The requirement of 14.3.1.2.2 is equivalent to the following two constraints:
 - (a) The return loss when measured with an 85Ω resistive source is at least 15 dB in the frequency range of 5 MHz to 10 MHz.
 - (b) The return loss when measured with a 111Ω resistive source is at least 15 dB in the frequency range of 5 MHz to 10 MHz.

A4.3.3 Note for 14.3.1.2.3 on Output Timing Jitter. Adherence to the template of 14.3.1.2.1 with a jitterless source driving DO and the zero crossings constrained to 46.5 ns to 53.5 ns and 96.5 ns to 103.5 ns is sufficient to demonstrate compliance with the 3.5 ns jitter requirement. When measuring an integrated MAU, the zero crossing time interval should be constrained to 44.5 ns to 55.5 ns and 94.5 ns to 105.5 ns due to the additional allocation for encoder and AUI jitter. This test is simpler to perform than the test which follows, but failure of this test does not demonstrate noncompliance.

When triggering on one edge of the transmitted signal and observing another edge, the observed jitter measures the difference between the jitter of the triggering edge and the observed edge. When the two

edges are separated such that the jitter of the edges is independent and clock drift is insignificant, the observed jitter is twice that of a single edge.

Therefore, a test that demonstrates compliance or noncompliance is as follows: Observe the zero crossings 8 BT and 8.5 BT from the triggering zero crossing while transmitting a pseudo-random data sequence of at least 511 bits. An external MAU with a jitterless source driving DO is compliant when all zero crossings fall within the time intervals $8.0 \text{ BT} \pm 7 \text{ ns}$ and $8.5 \text{ BT} \pm 7 \text{ ns}$. An integrated MAU is compliant when all zero crossings fall within the time intervals $8.0 \text{ BT} \pm 11 \text{ ns}$ and $8.5 \text{ BT} \pm 11 \text{ ns}$.

When using packetized data, the TP_IDL and the first transmitted bit should be excluded from these measurements.

A4.3.4 General Note on Common-Mode Tests. When performing tests specified as balanced or common-mode, the balance of the test equipment (such as matching resistors) must exceed that required by the test.

A4.3.5 Note for 14.3.1.3.4 on Receiver Differential Input Impedance. The return loss (RL) is defined as follows:

$$RL = 20 \log_{10} \frac{|Z_{\text{receiver}} + Z_{\text{cable}}|}{|Z_{\text{receiver}} - Z_{\text{cable}}|}$$

and also

$$RL = 20 \log_{10} \frac{|V_i|}{|V_r|}$$

where

Z_{receiver} is the impedance of the receiver

Z_{cable} is the impedance of the cable

V_i is the differential voltage incident upon the receiver

V_r is the differential voltage reflected from the receiver

- (1) A receiver with a resistive input impedance of $96 \Omega \pm 20\%$ will satisfy this requirement.
- (2) The requirement of 14.3.1.3.4 is equivalent to the following two constraints:
 - (a) The return loss when measured with an 85Ω resistive source is at least 15 dB in the frequency range of 5 MHz to 10 MHz.
 - (b) The return loss when measured with a 111Ω resistive source is at least 15 dB in the frequency range of 5 MHz to 10 MHz.

A4.3.6 Note for 14.3.1.3.3 on Receiver Idle Input Behavior. For conformance testing of receivers, the start of idle shall conform to the template shown in Fig 14-10. Additionally, the magnitude of the voltage-time integral of the undershoot (measured from the negative zero crossing that ends the positive idle pulse to the time when the differential signal settles to $0.0 \text{ mV} \pm 50 \text{ mV}$) shall be no greater than 1.2 times the voltage-time integral of the positive idle pulse (measured from the last positive zero crossing to the negative zero crossing).

A4.3.7 Note for 14.3.1.3.5 on Receiver Common-Mode Rejection. For a stand-alone MAU, the receiver common-mode test may be performed with a jitterless E_g , so that the DI circuit should have no more than 4.0 ns of edge jitter.

For an integrated MAU, the common-mode test is performed with an E_g that has zero crossing jitter up to 11 ns from the ideal.

Table B1
Transmit Component State Transition

Current State	Event	Action	Next State
0. Start	Initializ.	- Perform Initialization	Idle
1. Idle	Data Request	- Construct Frame - Start Frame Transmission	Transmit
	Carrier On	- No Action	Defer No Wait
2. Transmit	Preamble Done AND Collision Detect Up Transmit Done	- Start Jam Transmission - Increment Attempt Count - Start Delay Timer - Reset Attempt Count - Indicate successful Transmission	Jam Delay No Wait
3. Jam	Transmit Done	- Start Delay Timer - Start Backoff Timer	Backoff Delay
	Excessive Collisions	- Start Delay Timer - Indicate Transmit Excessive Collisions	Delay No Wait
4. Backoff	Carrier On Backoff Timeout	- No Action - Start Frame Transmission	Backoff Defer Transmit
5. Backoff Defer	Carrier Off Backoff Timeout	- Start Delay Timer - No Action	Backoff Delay Defer Wait
6. Backoff Delay	Carrier On Delay Timeout Backoff Timeout	- Stop Delay Timer - No Action - No Action	Backoff Defer Backoff Delay Wait
7. Defer No Wait	Data Request Carrier Off	- Construct Frame - Start Delay Timer	Defer Wait Delay No Wait
8. Delay No Wait	Data Request Delay Timeout	- Construct Frame - No Action	Delay Wait Idle
9. Defer Wait	Carrier Off	- Start Delay Timer	Delay Wait
10. Delay Wait	Delay Timeout	- Start Frame Transmission	Transmit

Carrier On. This event indicates that the physical layer has detected a change in carrier sense from no carrier to carrier.

Carrier Off. This event indicates that the physical layer has detected a change in the state of carrier sense from carrier to no carrier.

Preamble Done AND Collision Detect Up. This event indicates that the physical layer has detected a collision with the frame being transmitted and the transmission of the preamble sequence is completed.

Delay Timeout. This event indicates that the interframe time delay has completed.

Backoff Timeout. This event indicates that the time period for backing off has completed.

Transmit Done. The bit transmitter has transmitted all of the bits in the transmit buffer specified by the transmit buffersize (which includes preamble and data).

Excessive Collisions. The bit transmitter has transmitted all of the bits in the transmit buffer specified by the transmit buffersize, and the attempt count is equal to the maximum transmit attempt count allowed.

B2.3 Transmit Component Action Descriptions

Construct Frame. This action encapsulates the data field with the Preamble, SFD, DA, SA, Length, PAD, and FCS fields.

Start Frame Transmission. This action initiates bit transmission of the frame.

Start Jam Transmission. This action causes the bit transmitter to transmit the bits of the jam pattern.

Indicate Successful Transmission. This action reports that the transmission was successful.

Indicate Transmit Failure. This action reports the failure of transmission and the reason.

Increment Attempt Count. This action increments the counter used to record the number of attempts made to transmit the same frame.

Reset Attempt Count. This action initializes the attempt count to 0.

Start Backoff Timer. This action computes the random backoff delay time and sets the backoff timer to that time.

Start Delay Timer. This action sets the delay timer to the interframe gap time.

Stop Delay Timer. This action turns the delay timer off.

Perform Initialization. This action turns all timers off and ensures that carrier is considered off and collision detect down. All counters are reset. Any implementation specific variables are initialized.

B2.4 Transmit Component State Descriptions

Start. The transmit component has not been initialized by management.

Idle. The transmit component is not transmitting any data nor is it in a state where it is prevented from transmitting data.

Transmit. The transmit component is actively transmitting bits onto the medium.

Jam. The transmit component is actively transmitting jam bits onto the medium.

Backoff. The transmit component is waiting for its random backoff delay to expire before attempting to retransmit a frame.

Backoff Defer. The transmit component is waiting for both the medium to become available and for its backoff time delay to expire before attempting to retransmit a frame.

Backoff Delay. The transmit component is waiting for the interframe gap and the backoff delays to expire before attempting to retransmit a frame.

Defer No Wait. The transmit component has no frame to transmit and it cannot transmit one if it gets one because the medium is busy.

Delay No Wait. The transmit component has no frame to transmit and it could not if it had one because it is waiting for the interframe gap time to expire.

Defer Wait. The transmit component is waiting for the medium to become free before attempting to transmit or retransmit the frame.

Delay Wait. The transmit component is waiting for the interframe gap time to expire before attempting to transmit or retransmit the frame.

B3. Receive Component Overview

The receive component is responsible for handling all events that affect the reception of a frame from the media. (See Fig B2 and Table B2.)

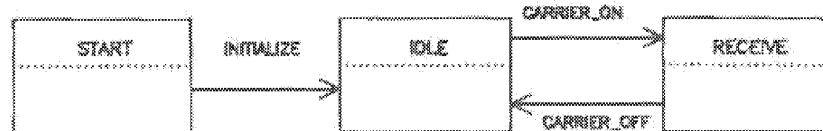

Fig B2
Receive Component State Diagram

Table B2
Receive Component State Transition

Current State	Event	Action	Next State
0. Start	Initialize	- Perform Initialization	Idle
1. Idle	Carrier On	- Start Receiving	Receive
2. Receive	Carrier Off	- Process Frame Received	Idle

B3.1 Receive Component Event Descriptions

Initialize. This event is generated by management to start up the component.

Carrier On. This event indicates that the physical layer has detected a change in carrier sense from no carrier to carrier.

Carrier Off. This event indicates that the physical layer has detected a change in the state of carrier sense from carrier to no carrier.

B3.2 Receive Component Action Descriptions

Perform Initialization. This action turns all timers off and ensures that carrier is considered off and collision detect down. All counters are reset. Any implementation specific variables are initialized.

Start Receiving. This action begins the processes of accepting bits and appending them to the buffer used to contain the frame.

Process Frame Received. If the frame is not addressed to this station, then ignore the frame. Otherwise, check the frame for errors. If there are no errors, pass frame up to the LLC sublayer indicating no error. Otherwise, pass the frame to the LLC sublayer indicating the error.

88.5 Receive Component State Descriptions

Start. The receive component has not been initialized by management.

Idle. The receive component is not actively receiving bits of data from the line.

Receive. The receive component is receiving bits of data from the line.

Appendix C Application Context, Selected Medium Specifications

C1. Introduction

This Appendix provides general guidance, to both the design engineer and the eventual user of specific product implementations, on what particular sections of the ISO 8802-3 CSMA/CD Local Area Network Standard might be considered useful for different application environments. It is to be emphasized that the material in this Appendix is very general, as the standard specifications are intended to be relatively application-independent. Nevertheless, certain specifications may apply more to one application environment than another. What follows are brief descriptions of application environments and lists of those generic parameters of the physical layer specifications thought to be useful in relating a general set of user requirements to a specific standard specification and its related medium. *Once a basic relationship is identified, the reader is directed to a specific section of the standard for detailed design specifications.*

C2. Type 10BASE5 Applications

One of the major arenas for local area networks is the interconnection of work stations throughout a large department or single building. The ability to handle all kinds of message traffic at relatively high data rates among a large set of work stations are typical characteristics of these environments. Usually the basic interconnection trunk cable is installed and left in place permanently or for extended periods while work station placement may shift from time to time. The Type 10BASE5 specification provides the primary baseband backbone for intraplant CSMA/CD interconnections. Sections 7 and 8 of the standard provide detailed specifications for the physical layers associated with Type 10BASE5 environments. The generic physical layer parameters are as follows:

Maximum unrepeateread cable segment	500 m
Maximum number of MAUs per segment	100
Connector type	Type N or coaxial "tap"
Breakdown voltage, MAU function	250 V ac rms
MTBF	1 million hours
Total Segment Resistance	5 Ω
MAU separation	2.5 m
Connection shunt capacitance	4 pF
AUI functionality	D0, D1, C1, (CO optional)

C3. Type 10BASE2 Applications

Another major arena for local area networks is the interconnection of work stations throughout a small department or work area. The ability to handle all kinds of message traffic at relatively high data rates among a selected set of locally clustered work stations are the typical characteristics of these environments. In addition, the basic interconnection trunk cable is likely to be moved frequently by the local users of the equipment to suit evolving needs. The Type 10BASE2 specification provides an interconnection schema that complements the Type 10BASE5 backbone in a hierarchical manner for intradepartment or work area CSMA/CD interconnections. Sections 7 and 10 of the standard provide detailed specifications for the physical layers associated with Type 10BASE2 environments. The generic physical layer parameters are as follows:

Maximum unrepeatered cable segment	185 m
Maximum number of MAUs per segment	30
Connector type	Type BNC "T"
Breakdown voltage, MAU function	500 V ac rms
MTEF	100 000 hours
Total Segment Resistance	10 Ω
MAU separation	0.5 m
Connection shunt capacitance	8 pF
AUI functionality	DO, DI, CI

C4. Type FOIRL Applications

Applications information for use of 50/125 μm optical fiber is under consideration.

Appendix D

Receiver Wavelength Design Considerations

Reference 9.9.4.1.1, wavelength.

The center wavelength of the optical source emission is currently specified to be between 790 nm and 860 nm. Although these limits are acceptable, it is currently recognized, through the examination of manufacturers' current data, that greater choices of emitters can be obtained by extending the allowable wavelength to 910 nm.

An upper limit of 910 nm allows the selection of devices nominally centered at a lower wavelength, for example, 880 nm. This allows a tolerance for manufacturing variations, for example, ± 20 nm, and a tolerance for an operating temperature range (typically, 0.3 nm/ $^{\circ}$ C).

It is anticipated that future fiber optic applications including Local Area Networks will use the 910 nm upper limit for first window systems. It is therefore recommended that implementers specify receiver sensitivity over a center wavelength range from 790 nm to 910 nm.

ISO/IEC 8802-3:1993(E)
ANSI/IEEE Std 802.3, 1993 edition

UDC 681.3:621.39

Descriptors: data processing, information interchange, network interconnection, local area networks, models, mode of data transmission.

Price based on 304 pages
