



(12) **United States Patent**
Tasler

(10) **Patent No.: US 6,470,399 B1**
(45) **Date of Patent: Oct. 22, 2002**

(54) **FLEXIBLE INTERFACE FOR COMMUNICATION BETWEEN A HOST AND AN ANALOG I/O DEVICE CONNECTED TO THE INTERFACE REGARDLESS THE TYPE OF THE I/O DEVICE**

FOREIGN PATENT DOCUMENTS

DE	195 28 889	A1	2/1997
EP	0 436 458	A2	7/1991
EP	0 685 799	A1	12/1995
JP	06301607	A	10/1994
JP	08110883	A	4/1996
WO	WO94/19746		9/1994

(75) Inventor: **Michael Tasler, Würzburg (DE)**

OTHER PUBLICATIONS

Steve Martin, "PC-based Data Acquisition in an Industrial Environment," pp. 1-3 (1990).
 Payne et al., "High Speed PC-based Data Acquisition Systems," IEEE, pp. 2140-2145 (1995).
 National Instruments Corporation, "Dynamic Signal Acquisition and DSP Board for the PC AT," IEEE 488 and VXibus Control, Data Acquisition, and Analysis, pp. 3-118-3-123, (1994).
 IBM Corporation, "Communication Method between Devices through FDD Interface," IBM Technical Disclosure Bulletin, vol. 38 (No. 05), p. 245 (May, 1995).

(73) Assignee: **Labortechnik Tasler GmbH, Würzburg (DE)**

(*) Notice: Subject to any disclaimer, the term of this patent is extended or adjusted under 35 U.S.C. 154(b) by 0 days.

* cited by examiner

(21) Appl. No.: **09/331,002**

Primary Examiner—Thomas Lee

(22) PCT Filed: **Mar. 3, 1998**

Assistant Examiner—Thuan Du

(86) PCT No.: **PCT/EP98/01187**

§ 371 (c)(1),
(2), (4) Date: **Jun. 14, 1999**

(87) PCT Pub. No.: **WO98/39710**

PCT Pub. Date: **Sep. 11, 1998**

(74) *Attorney, Agent, or Firm*—Patton Boggs LLP

(30) **Foreign Application Priority Data**

(57) **ABSTRACT**

Mar. 4, 1997 (DE) 197 08 755

(51) **Int. Cl.**⁷ **G06F 13/14**

An interface device (10) provides fast data communication between a host device with input/output interfaces and a data transmit/receive device, wherein the interface device (10) comprises a processor means (13), a memory means (14), a first connecting device (12) for interfacing the host device with the interface device, and a second connecting device (15) for interfacing the interface device (10) with the data transmit/receive device. The interface device (10) is configured by the processor means (13) and the memory means (14) in such a way that, when receiving an inquiry from the host device via the first connecting device (12) as to the type of a device attached to the host device, regardless of the type of the data transmit/receive device, the interface device sends a signal to the host device via the first connecting device (12) which signals to the host device that it is communicating with an input/output device.

(52) **U.S. Cl.** **710/16; 710/62; 710/63**

(58) **Field of Search** **710/15, 16, 11, 710/12, 62, 63, 64; 703/23, 24, 25**

(56) **References Cited**

U.S. PATENT DOCUMENTS

5,291,611	A	3/1994	Davis et al.	
5,297,124	A *	3/1994	Plotkin et al.	703/25
5,430,855	A *	7/1995	Walsh et al.	703/23
5,444,644	A	8/1995	Divjak	
5,487,154	A	1/1996	Gunji	
5,499,378	A *	3/1996	McNeill et al.	703/24
5,506,692	A	4/1996	Murata	
5,510,774	A	4/1996	Loncle	
5,548,783	A *	8/1996	Jones et al.	710/15
6,012,113	A *	1/2000	Tuckner	710/64

15 Claims, 2 Drawing Sheets

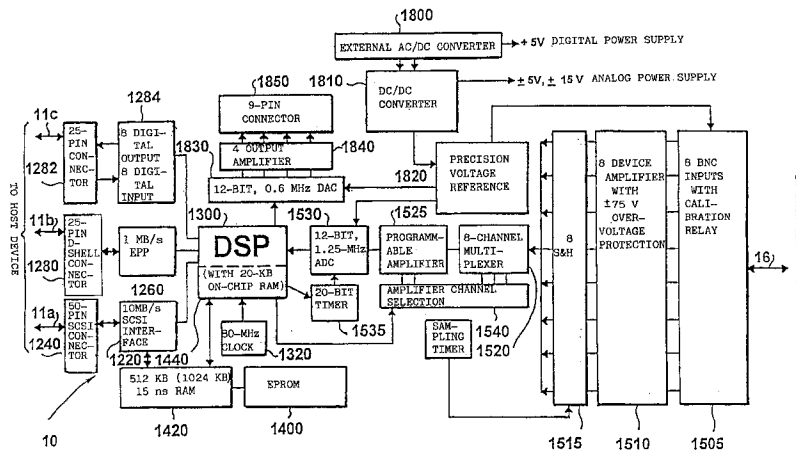

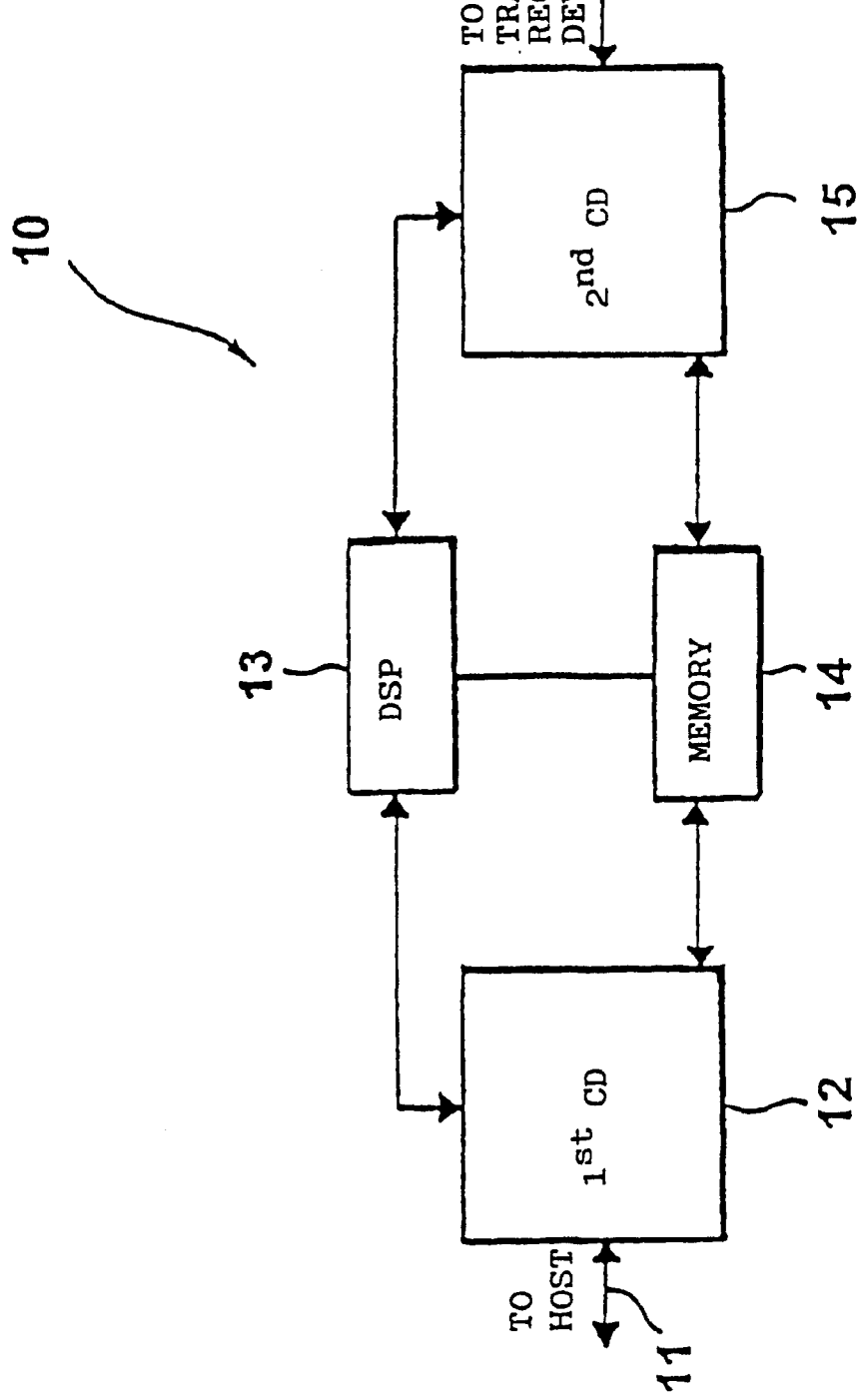

FIG. 1

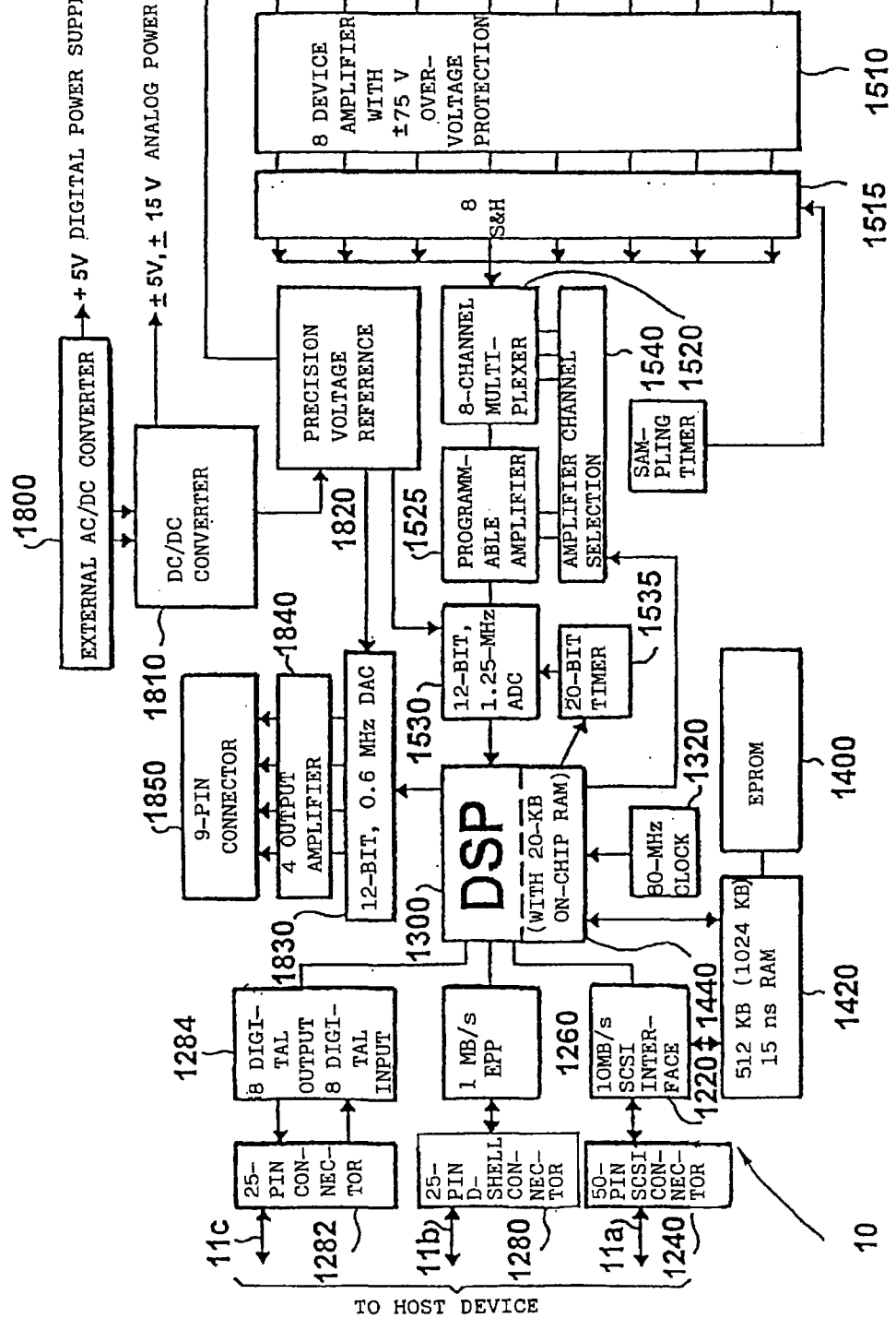

FIG. 2

1

**FLEXIBLE INTERFACE FOR
COMMUNICATION BETWEEN A HOST AND
AN ANALOG I/O DEVICE CONNECTED TO
THE INTERFACE REGARDLESS THE TYPE
OF THE I/O DEVICE**

FIELD OF THE INVENTION

The present invention relates to the transfer of data and in particular to interface devices for communication between a computer or host device and a data transmit/receive device from which data is to be acquired or with which two-way communication is to take place.

BACKGROUND OF THE INVENTION

Existing data acquisition systems for computers are very limited in their areas of application. Generally such systems can be classified into two groups.

In the first group host devices or computer systems are attached by means of an interface to a device whose data is to be acquired. The interfaces of this group are normally standard interfaces which, with specific driver software, can be used with a variety of host systems. An advantage of such interfaces is that they are largely independent of the host device. However, a disadvantage is that they generally require very sophisticated drivers which are prone to malfunction and which limit data transfer rates between the device connected to the interface and the host device and vice versa. Further, it is often very difficult to implement such interfaces for portable systems and they offer few possibilities for adaptation with the result that such systems offer little flexibility.

The devices from which data is to be acquired cover the entire electrical engineering spectrum. In a typical case, it is assumed that a customer who operates, for example, a diagnostic radiology system in a medical engineering environment reports a fault. A field service technician of the system manufacturer visits the customer and reads system log files generated by the diagnostic radiology system by means of a portable computer or laptop for example. If the fault cannot be localized or if the fault is intermittent, it will be necessary for the service technician to read not only an error log file but also data from current operation. It is apparent that in this case fast data transfer and rapid data analysis are necessary.

Another case requiring the use of an interface could be, for example, when an electronic measuring device, e.g. a multimeter, is attached to a computer system to transfer the data measured by the multimeter to the computer. Particularly when long-term measurements or large volumes of data are involved it is necessary for the interface to support a high data transfer rate.

From these randomly chosen examples it can be seen that an interface may be put to totally different uses. It is therefore desirable that an interface be sufficiently flexible to permit attachment of very different electrical or electronic systems to a host device by means of the interface. To prevent operator error, it is also desirable that a service technician is not required to operate different interfaces in different ways for different applications but that, if possible, a universal method of operating the interface be provided for a large number of applications.

To increase the data transfer rates across an interface, the route chosen in the second group of data acquisition systems for the interface devices was to specifically match the

2

interface very closely to individual host systems or computer systems. The advantage of this solution is that high data transfer rates are possible. However, a disadvantage is that the drivers for the interfaces of the second group are very closely matched to a single host system with the result that they generally cannot be used with other host systems or their use is very ineffective. Further, such types of interface have the disadvantage that they must be installed inside the computer casing to achieve maximum data transfer rates as they access the internal host bus system. They are therefore generally not suitable for portable host systems in the form of laptops whose minimum possible size leaves little internal space to plug in an interface card.

DESCRIPTION OF PRIOR ART

A solution to this problem is offered by the interface devices of Iotech (business address: 25971 Cannon Road, Cleveland, Ohio 44146, USA) which are suitable for laptops such as the WaveBook/512 (registered trademark). The interface devices are connected by means of a plug-in card, approximately the size of a credit card, to the PCMCIA interface which is now a standard feature in laptops. The plug-in card converts the PCMCIA interface into an interface known in the art as IEEE 1284. The said plug-in card provides a special printer interface which is enhanced as regards the data transfer rate and delivers a data transfer rate of approximately 2 MBps as compared with a rate of approx. 1 MBps for known printer interfaces. The known interface device generally consists of a driver component, a digital signal processor, a buffer and a hardware module which terminates in a connector to which the device whose data is to be acquired is attached. The driver component is attached directly to the enhanced printer interface thus permitting the known interface device to establish a connection between a computer and the device whose data is to be acquired.

In order to work with the said interface, an interface-specific driver must be installed on the host device so that the host device can communicate with the digital signal processor of the interface card. As described above, the driver must be installed on the host device. If the driver is a driver developed specifically for the host device, a high data transfer rate is achieved but the driver cannot be easily installed on a different host system. However, if the driver is a general driver which is as flexible as possible and which can be used on many host devices, compromises must be accepted with regard to the data transfer rate.

Particularly in an application for multi-tasking systems in which several different tasks such as data acquisition, data display and editing are to be performed quasi-simultaneously, each task is normally assigned a certain priority by the host system. A driver supporting a special task requests the central processing system of the host device for processor resources in order to perform its task. Depending on the particular priority assignment method and on the driver implementation, a particular share of processor resources is assigned to a special task in particular time slots. Conflicts arise if one or more drivers are implemented in such a way that they have the highest priority by default, i.e. they are incompatible, as happens in practice in many applications. It may occur that both drivers are set to highest priority which, in the worst case, can result in a system crash.

EP 0685799 A1 discloses an interface by means of which several peripheral devices can be attached to a bus. An interface is connected between the bus of a host device and various peripheral devices. The interface comprises a finite

state machine and several branches each of which is assigned to a peripheral device. Each branch comprises a data manager, cycle control, user logic and a buffer. This known interface device provides optimal matching between a host device and a specific peripheral device.

The specialist publication IBM Technical Disclosure Bulletin, Vol. 38, No. 05, page 245; "Communication Method between Devices through FDD Interface" discloses an interface which connects a host device to a peripheral device via a floppy disk drive interface. The interface consists in particular of an address generator, an MFM encoder/decoder, a serial/parallel adapter and a format signal generator. The interface makes it possible to attach not only a floppy disk drive but also a further peripheral device to the FDD host controller of a host device. The host device assumes that a floppy disk drive is always attached to its floppy disk drive controller and communication is initiated if the address is correct. However, this document contains no information as to how communication should be possible if the interface is connected to a multi-purpose interface instead of to a floppy disk drive controller.

SUMMARY OF THE INVENTION

It is an object of the present invention to provide an interface device for communication between a host device and a data transmit/receive device whose use is host device-independent and which delivers a high data transfer rate.

In accordance with a first aspect of the present invention, this object is met by an interface device for communication between a host device, which comprises drivers for input/output devices customary in a host device and a multi-purpose interface, and a data transmit/receive device comprising: a processor; a memory; a first connecting device for interfacing the host device with the interface device via the multi-purpose interface of the host device; and a second connecting device for interfacing the interface device with the data transmit/receive device, wherein the interface device is configured by the processor and the memory in such a way that the interface device, when receiving an inquiry from the host device as to the type of a device attached to the multi-purpose interface of the host device, sends a signal, regardless of the type of the data transmit/receive device attached to the second connecting device of the interface device, to the host device which signals to the host device that it is an input/output device customary in a host device, whereupon the host device communicates with the interface device by means of the driver for the input/output device customary in a host device.

In accordance with a second aspect of the present invention, this object is met by an interface device for communication between a host device, which comprises a multi-purpose interface and a specific driver for this interface, and a data transmit/receive device comprising: a processor; a memory; a first connecting device for interfacing the host device with the interface device via the multi-purpose interface of the host device; and a second connecting device for interfacing the interface device with the data transmit/receive device, wherein the interface device is configured using the processor and the memory in such a way that the interface device, when receiving an inquiry from the host device as to the type of a device attached at the multi-purpose interface of the host device, sends a signal, regardless of the type of the data transmit/receive device attached to the second connecting device of the interface device, to the host device which signals to the host device that it is an input/output device customary in a host device

whereupon the host device communicates with the interface device by means of the specific driver for the multi-purpose interface.

In accordance with a third aspect of the present invention, this object is met by a method of communication between a host device, which comprises drivers for input/output devices customary in a host device and a multi-purpose interface, and a data transmit/receive device via an interface device comprising the steps of interfacing of the host device with a first connecting device of the interface device via the multi-purpose interface of the host device; interfacing of the data transmit/receive device with a second connecting device of the interface device; inquiring by the host device at the interface device as to the type of device to which the multi-purpose interface of the host device is attached; regardless of the type of the data transmit/receive device attached to the second connecting device of the interface device, responding to the inquiry from the host device by the interface device in such a way that it is an input/output device customary in a host device, whereupon the host device communicates with the interface device by means of the usual driver for the input/output device.

The present invention is based on the finding that both a high data transfer rate and host device-independent use can be achieved if a driver for an input/output device customary in a host device, normally present in most commercially available host devices, is utilized. Drivers for input/output devices customary in a host device which are found in practically all host devices are, for example, drivers for hard disks, for graphics devices or for printer devices. As however the hard disk interfaces in common host devices which can be, for example, IBM PCs, IBM-compatible PCs, Commodore PCs, Apple computers or even workstations, are the interfaces with the highest data transfer rate, the hard disk driver is utilized in the preferred embodiment of the interface device of the present invention. Drivers for other storage devices such as floppy disk drives, CD-ROM drives or tape drives could also be utilized in order to implement the interface device according to the present invention.

As described in the following, the interface device according to the present invention is to be attached to a host device by means of a multi-purpose interface of the host device which can be implemented, for example, as an SCSI interface or as an enhanced printer interface. Multi-purpose interfaces comprise both an interface card and specific driver software for the interface card. The driver software can be designed so that it can replace the BIOS driver routines. Communication between the host device and the devices attached to the multi-purpose interface then essentially takes place by means of the specific driver software for the multi-purpose interface and no longer primarily by means of BIOS routines of the host device. Recently however drivers for multi-purpose interfaces can also already be integrated in the BIOS system of the host device as, alongside classical input/output interfaces, multi-purpose interfaces are becoming increasingly common in host devices. It is of course also possible to use BIOS routines in parallel with the specific driver software for the multi-purpose interface, if this is desired.

The interface device according to the present invention comprises a processor means, a memory means, a first connecting device for interfacing the host device with the interface device, and a second connecting device for interfacing the interface device with the data transmit/receive device. The interface device is configured by the processor means and the memory means in such a way that the interface device, when receiving an inquiry from the host

Explore Litigation Insights

Docket Alarm provides insights to develop a more informed litigation strategy and the peace of mind of knowing you're on top of things.

Real-Time Litigation Alerts



Keep your litigation team up-to-date with **real-time alerts** and advanced team management tools built for the enterprise, all while greatly reducing PACER spend.

Our comprehensive service means we can handle Federal, State, and Administrative courts across the country.

Advanced Docket Research



With over 230 million records, Docket Alarm's cloud-native docket research platform finds what other services can't. Coverage includes Federal, State, plus PTAB, TTAB, ITC and NLRB decisions, all in one place.

Identify arguments that have been successful in the past with full text, pinpoint searching. Link to case law cited within any court document via Fastcase.

Analytics At Your Fingertips



Learn what happened the last time a particular judge, opposing counsel or company faced cases similar to yours.

Advanced out-of-the-box PTAB and TTAB analytics are always at your fingertips.

API

Docket Alarm offers a powerful API (application programming interface) to developers that want to integrate case filings into their apps.

LAW FIRMS

Build custom dashboards for your attorneys and clients with live data direct from the court.

Automate many repetitive legal tasks like conflict checks, document management, and marketing.

FINANCIAL INSTITUTIONS

Litigation and bankruptcy checks for companies and debtors.

E-DISCOVERY AND LEGAL VENDORS

Sync your system to PACER to automate legal marketing.