

No. 2014-1110

UNITED STATES COURT OF APPEALS FOR THE FEDERAL CIRCUIT

IN RE PAPST LICENSING DIGITAL CAMERA
PATENT LITIGATION

PAPST LICENSING GMBH & CO. KG,

Plaintiff-Appellant,

v.

FUJIFILM CORPORATION, FUJIFILM NORTH AMERICA CORPORATION (formerly known as FUJIFILM USA, INC.), HEWLETT-PACKARD COMPANY, JVC COMPANY OF AMERICA, NIKON CORPORATION, NIKON, INC., OLYMPUS CORP., OLYMPUS IMAGING AMERICA INC., PANASONIC CORPORATION (formerly known as MATSUSHITA ELECTRIC INDUSTRIAL CO., LTD.), PANASONIC CORPORATION OF NORTH AMERICA, SAMSUNG OPTO-ELECTRONICS AMERICA, INC., SAMSUNG TECHWIN CO., AND VICTOR COMPANY OF JAPAN, LTD.,

Defendant-Appellees.

Appeal from the United States District Court for the District of Columbia in Case No. 1:07-mc-00493-RMC, United States District Judge Rosemary M. Collyer

**BRIEF FOR PLAINTIFF-APPELLANT
PAPST LICENSING GMBH & CO. KG**

*Attorneys for Plaintiff-Appellant
Papst Licensing GmbH & Co. KG*

February 20, 2014

Alan M. Fisch
R. William Sigler
John T. Battaglia
Thomas C. Chen
FISCH HOFFMAN SIGLER LLP
5335 Wisconsin Avenue NW
Eighth Floor
Washington, DC 20015
(202) 362-3500

CERTIFICATE OF INTEREST

Counsel for Plaintiff-Appellant Papst Licensing GmbH & Co. KG. certifies:

1. The full name of every party or amicus represented by me is:

Papst Licensing GmbH & Co. KG

2. The name of the real party in interest (if the party named in the caption is not the real party in interest) represented by me is:

Not Applicable

3. All parent corporations and any publicly held companies that own 10 percent or more of the stock of the parties or amicus represented by me are:

None

4. The names of all law firms and partners or associates that appeared for the party or amicus now represented by me in the trial court or agency or are expected to appear in this court are:

Fisch Hoffman Sigler LLP: Alan M. Fisch; Roy William Sigler; John T. Battaglia, Thomas C. Chen

Husch Blackwell LLP: Jerold B. Schnayer; Walter J. Kawula, Jr.; William Francis Demarest, Jr.; James P. White; John Aron Carnahan; Joseph E. Cwik; Raymond R. Ricordati, III; Daniel R. Cherry; Yasmin S. Schnayer

Stein Mitchell & Muse, LLP: Robert F. Muse

Date: February 20, 2014

/s/ John T. Battaglia
John T. Battaglia

TABLE OF CONTENTS

CERTIFICATE OF INTEREST i

TABLE OF AUTHORITIES vii

STATEMENT OF RELATED CASES xiii

JURISDICTIONAL STATEMENT 1

INTRODUCTION 2

STATEMENT OF THE ISSUES 6

STATEMENT OF THE CASE 7

 I. THE PATENTS-IN-SUIT 7

 A. Background of the Invention: Interface Devices
 and Drivers 7

 1. Prior Art Interface Devices Suffered
 Undesirable Tradeoffs Between Flexibility
 Versus Speed 8

 a. Prior Art Interface Devices 8

 b. Prior Art Interface Devices Could Be
 Used in Specific Configurations for
 Specific Applications 10

 2. The Claimed Interface Device
 Simultaneously Achieves Both Flexibility
 and Speed By Relying on Host Drivers 11

 a. The Claimed Interface Device 12

 b. The Claimed Interface Device Can Be
 Used in Specific Configurations for
 Specific Applications 12

 3. The Patents Describe Various Embodiments
 of the Claimed Invention to Demonstrate Its

Overall Superiority—*Independent* of Any
Specific Structure or Use14

B. The Independent Claims Broadly Define the
Interface Device Without Specifying Any
Particular Structure or Use.....15

C. The Specification Discloses Various Ways in
Which the Interface Device and Its Components
May Be “Attached”20

D. The Specification Discloses Various “Customary”
Input/Output Devices That May Be Simulated By
the Claimed Interface Device.....21

E. The File History Confirms Patentability Did Not
Turn on Any Specific Structural Configurations,
Uses, or Types of Devices22

II. THE ACCUSED PRODUCTS.....22

III. THE DISTRICT COURT PROCEEDINGS23

A. Papst’s History of Innovation and Licensing.....23

B. Litigation Began After Unsuccessful Licensing
Negotiations24

C. The District Court Narrowly Construed Several
Claim Limitations and Granted Summary
Judgment25

SUMMARY OF ARGUMENT27

I. THE DISTRICT COURT REPEATED TWO
FUNDAMENTAL CLAIM CONSTRUCTION
ERRORS27

A. The District Court Wrongly Construed the
Claimed “Interface Device” as a Separate, Stand-
Alone Structure27

B. The District Court Wrongly Construed Single Words In Isolation, Divorced From Their Proper Context27

STANDARD OF REVIEW28

ARGUMENT29

I. THE DISTRICT COURT ERRED IN CONSTRUING “INTERFACE DEVICE” TO REQUIRE A STAND-ALONE STRUCTURE29

A. Papst’s Construction Is Correct Based on the Intrinsic Record and This Court’s Precedent.....30

1. The Claims Do Not Include Language Limiting the “Interface Device” to a Separate Stand-Alone Structure30

2. Nothing in the Specification Limits the Claimed “Interface Device” to a Separate, Stand-Alone Structure33

3. This Court Has Repeatedly Held That Separate Claim Elements Do *Not* Require Separate, Stand-Alone Structures35

B. The District Court’s Construction of “Interface Device” Relied on Additional Errors.....38

1. The District Court Further Read “Attached” as Requiring the “Interface Device” *Not* Have “Permanent” Attachments.....39

2. The District Court Improperly Relied on the Specification’s Embodiments and Figures to Narrow the Claims39

3. The District Court Misread Statements Regarding “Desirable” Flexibility to Narrow the Claims42

4. The District Court Misinterpreted the “Enormous Advantage” Discussion to Narrow the Claims43

5. The District Court Improperly Relied on the Patents’ “Title” to Narrow the Claims.....45

6. The District Court’s Construction for “Interface Device” Conflicts With Its Broader Construction for “Interfacing”46

II. THE DISTRICT COURT MISCONSTRUED “DATA TRANSMIT/RECEIVE DEVICE”47

A. Papst’s Construction Is Correct Under the Intrinsic Record47

1. The Claim Language Allows Data Transfer Between the DTRD and Interface Device, Without Need for Any Further Connection to a Host Device.....47

2. The Specification Supports This “DTRD” Construction.....49

B. The District Court’s Construction is Erroneous50

III. THE DISTRICT COURT MISCONSTRUED “INPUT/OUTPUT [STORAGE] DEVICE CUSTOMARY IN A HOST DEVICE”53

A. Papst’s Construction Is Correct Under the Intrinsic Record54

1. The Specification Discloses Several “Customary” Input/Output Devices That Can Be *Externally* Installed.....54

2. The District Court Erred By Construing “In” Rather Than “Input/Output Device Customary In a Host Device”56

IV. THE DISTRICT COURT ERRED IN CONSTRUING
“VIRTUAL FILES” AND “SIMULATING A VIRTUAL
FILE SYSTEM”57

A. Papst’s Construction Is Supported by the Intrinsic
Record58

1. The Specification Indicates the “Virtual
Files” and “Virtual File System” Reside on
the “Virtual Hard Disk”58

2. The Claims Confirm That “Virtual Files”
and the “Virtual File System” Are
Physically Stored on the Interface Device.....59

B. Defendants’ Construction Is Contrary to the
Intrinsic Record.....60

1. The District Court Erred By Construing
“Virtual” Instead of “Virtual Files” and
“Simulating a Virtual File System”60

2. The District Court’s Construction Renders
the Dependent Claims Inconsistent with the
Independent Claims63

3. The District Court’s Construction Renders
Dependent Claims Impermissibly Broader
Than Independent Claims63

V. THE COURT MISCONSTRUED “SECOND
CONNECTING DEVICE”64

VI. THE DISTRICT COURT’S RULINGS MUST BE
VACATED IN VIEW OF THE PROPER CLAIM
CONSTRUCTIONS66

CONCLUSION67

TABLE OF AUTHORITIES

Cases

<i>3M Innovative Props. Co. v. Avery Dennison Corp.</i> , 350 F.3d 1365 (Fed. Cir. 2003)	51
<i>3M Innovative Props. Co. v. Tredegar Corp.</i> , 725 F.3d 1315 (Fed. Cir. 2013)	49
<i>ACTV v. Walt Disney Co.</i> , 346 F.3d 1082 (Fed. Cir. 2003)	61
<i>Acumed LLC v. Stryker Corp.</i> , 483 F.3d 800 (Fed. Cir. 2007)	40, 42, 48
<i>Advanced Fiber Techs. Trust v. J&L Fiber Servs.</i> , 674 F.3d 1365 (Fed. Cir. 2012)	41, 43
<i>Advanced Software Design Corp. v. Fiserv, Inc.</i> , 641 F.3d 1368 (Fed. Cir. 2011)	64
<i>Agfa Corp. v. Creo Prods.</i> , 451 F.3d 1366 (Fed. Cir. 2006)	40
<i>AIA Eng’g Ltd. v. Magotteaux Int’l S/A</i> , 657 F.3d 1264 (Fed. Cir. 2011)	46, 66
<i>Alcon Research, Ltd. v. Apotex Inc.</i> , 687 F.3d 1362 (Fed. Cir. 2012)	64
<i>Anchor Wall Sys. v. Rockwood Retaining Walls</i> , 340 F.3d 1298 (Fed. Cir. 2003)	39
<i>Applied Med. Res. Corp. v. U.S. Surgical Corp.</i> , 448 F.3d 1324 (Fed. Cir. 2006)	29, 35
<i>Arlington Indus. v. Bridgeport Fittings, Inc.</i> , 632 F.3d 1246 (Fed. Cir. 2011)	39
<i>Brookhill-Wilk 1, LLC v. Intuitive Surgical, Inc.</i> , 334 F.3d 1294 (Fed. Cir. 2003)	53, 61

CCS Fitness v. Brunswick Corp.,
288 F.3d 1359 (Fed. Cir. 2002)30

Chiron Corp. v. Genentech, Inc.,
363 F.3d 1247 (Fed. Cir. 2004)41

Cybor Corp. v. FAS Techs., Inc.,
138 F.3d 1448 (Fed. Cir. 1998)28

Dorel Juvenile Group, Inc. v. Graco Children’s Prods.,
429 F.3d 1043 (Fed. Cir. 2005)33

Douglas Dynamics, LLC v. Buyers Prods., Co.,
717 F.3d 1336 (Fed. Cir. 2013)32

E-Pass Techs., Inc. v. 3COM Corp.,
343 F.3d 1364 (Fed. Cir. 2003)44

Fifth Generation Computer Corp. v. IBM,
416 Fed. Appx. 74 (Fed. Cir. 2011).....45

GE v. ITC,
685 F.3d 1034 (Fed. Cir. 2012)38

Gillette Co. v. Energizer Holdings, Inc.,
405 F.3d 1367 (Fed. Cir. 2005)51

Golight, Inc. v. Wal-Mart Stores, Inc.,
355 F.3d 1327 (Fed. Cir. 2004)44

Helmsderfer v. Bobrick Washroom Equip., Inc.,
527 F.3d 1379 (Fed. Cir. 2008)52

i4i Ltd. P’ship v. Microsoft Corp.,
598 F.3d 831 (Fed. Cir. 2010) 43, 44

IGT v. Bally Gaming Int’l, Inc.,
659 F.3d 1109 (Fed. Cir. 2011) 56, 61

In re Papst Licensing GmbH & Co. KG Litig.,
273 F.R.D. 339 (D.D.C. 2011).....26

In re Papst Licensing GmbH & Co. KG Litig.,
670 F. Supp. 2d 16 (D.D.C. 2009).....25

In re Papst Licensing GmbH & Co. KG Litig.,
932 F. Supp. 2d 14 (D.D.C. 2013).....26

In re Rasmussen,
650 F.2d 1212 (C.C.P.A. 1981)33

Innova/Pure Water, Inc. v. Safari Water Filtration Sys.,
381 F.3d 1111 (Fed. Cir. 2004)31

Inpro II Licensing, S.A.R.L. v. T-Mobile USA, Inc.,
450 F.3d 1350 (Fed. Cir. 2006)45

Intamin, Ltd. v. Magnetar Techs., Corp.,
483 F.3d 1328 (Fed. Cir. 2007)52

Intellectual Prop. Dev., Inc. v. UA-Columbia Cablevision of Westchester, Inc.,
336 F.3d 1308 (Fed. Cir. 2003)35

Johnson Worldwide Assocs. v. Zebco Corp.,
175 F.3d 985 (Fed. Cir. 1999)32

K-2 Corp. v. Salomon S.A.,
191 F.3d 1356 (Fed. Cir. 1999) 32, 33

Kyocera Wireless Corp. v. ITC,
545 F.3d 1340 (Fed. Cir. 2008)61

Laitram Corp. v. Cambridge Wire Cloth Co.,
863 F.2d 855 (Fed. Cir. 1988)43

Lighting World, Inc. v. Birchwood Lighting, Inc.,
382 F.3d 1354 (Fed. Cir. 2004)40

Linear Tech. Corp. v. ITC,
566 F.3d 1049 (Fed. Cir. 2009)37

MBO Labs., Inc. v. Becton, Dickinson & Co.,
474 F.3d 1323 (Fed. Cir. 2007) 39, 40

Medrad, Inc. v. MRI Devices Corp.,
401 F.3d 1313 (Fed. Cir. 2005)56

Minebea Co. v. Papst,
444 F. Supp. 2d 68 (D.D.C. 2006).....24

Northern Telecom Ltd. v. Samsung Elecs. Co.,
215 F.3d 1281 (Fed. Cir. 2000)34

NTP, Inc. v. Research in Motion, Ltd.,
418 F.3d 1282 (Fed. Cir. 2005) passim

Ottah v. Verifone Sys.,
524 Fed. Appx. 627 (Fed. Cir. 2013).....33

Paragon Solutions, LLC v. Timex Corp.,
566 F.3d 1075 (Fed. Cir. 2009)53

Phillips v. AWH Corp.,
415 F.3d 1303 (Fed. Cir. 2005) passim

Pitney Bowes, Inc. v. Hewlett-Packard Co.,
182 F.3d 1298 (Fed. Cir. 1999) 46, 51

Plantronics, Inc. v. Aliph, Inc.,
724 F.3d 1343 (Fed. Cir. 2013)30

Powell v. Home Depot, Inc.,
663 F.3d 1221 (Fed. Cir. 2011)38

Power-One, Inc. v. Artesyn Techs., Inc.,
599 F.3d 1343 (Fed. Cir. 2010)45

Rambus Inc. v. Rea,
731 F.3d 1248 (Fed. Cir. 2013)55

Retractable Techs., Inc. v. Becton,
653 F.3d 1296 (Fed. Cir. 2011)38

Rexnord Corp. v. Laitram Corp.,
274 F.3d 1336 (Fed. Cir. 2001)46

USE OF EMPHASIS IN QUOTATIONS

All emphasis in quotations and record citations has been added, unless otherwise indicated.

USE OF ILLUSTRATIVE SCHEMATIC DIAGRAMS

Papst has provided illustrative diagrams to assist the Court in understanding the technical and legal issues disputed by the parties below and on appeal.

STATEMENT OF RELATED CASES

Plaintiff-Appellant Papst Licensing GmbH & Co. KG (“Papst”) has asserted infringement of U.S. Patent Nos. 6,470,399 and 6,895,449 against other entities in the following actions:

08-cv-1406, *Papst v. Canon, Inc.*; and

09-cv-530, *Papst v. Sanyo Electric Co., Ltd.*

Those cases have been stayed and remain pending before the Honorable Rosemary M. Collyer in the United States District Court for the District of Columbia, and will be affected by the outcome of Papst’s appeal.

INTRODUCTION

The district court rendered five erroneous claim constructions because it (1) misunderstood the invention and (2) mis-applied this Court’s bedrock claim-construction principles. The result was an interpretation of the patents that bore little or no resemblance to the claim text and other intrinsic evidence, and erroneously led to summary judgment of noninfringement. Papst seeks an appropriate application of this Court’s precedent to the intrinsic record, which can only result in reversal of these constructions and a remand.

First, the district court improperly confined the “*interface device*” term to mean a stand-alone structure that is completely separate from the “data transmit receive device” (“DTRD”). The district court reached this construction based on the claim term “*attached*,” reasoning that it signified having a separate “interface device” “attached” to the DTRD. That rationale, however, contradicts this Court’s repeated and recent precedents holding that functional terms such as “attached” do *not* require physically separate structures. The court’s construction likewise conflicts with the specification’s use of “attached” to describe structures of the invention that are part of the *same* physical housing, i.e., structures that are *not* completely separate. Beyond that, the district court’s construction relied on the specification’s description of embodiments, what the patent Figures did *not* show, and the title of the patent, all of which are contrary to this Court’s prior holdings.

Second, the court misconstrued “***data transmit/receive device***” as requiring that the DTRD *not* “transfer data to the ‘interface device’ *until* the interface device” has already connected with a third structure, the “host device.” The claims, however, are silent about *when* this specific connection must occur. And the specification describes the invention as capable of performing in a manner that would not require connection with the “host device.” Disregarding these points, the court effectively required a sequence of steps based on the claims’ reference to “*first*” and “*second* connecting devices.” But “*first*” and “*second*” have an established meaning in patent parlance that refers to different instances of the same structure—*not* to performing steps in a particular “*first*” and “*second*” order. The court thus effectively imported a “*use*” requirement for claims directed to a *device*, contrary to this Court’s precedent.

Third, the court misconstrued “***input/output device customary in a host device***” as requiring an I/O device physically located “within the chassis of most ... computers.” This construction disregards the specification’s disclosure of several embodiments of I/O devices that reside outside the physical chassis of a computer, such as “printer devices.” Read in context, the claim limitation refers to devices commonly known and recognizable to a host computer, consistent with the purpose of the invention (namely, tricking the host computer into recognizing the attached device and using the computer’s own drivers to transfer data). The

district court instead extracted a single word—“in”—from the surrounding claim language and elevated its dictionary definition over the teachings of the specification. Under *Phillips*, such a construction cannot stand.

Fourth, for the '449 patent, the court misconstrued “*virtual files*” and “*simulating a virtual file system*” as requiring files “not physically stored” on the “interface device.” The claims and specification establish that, in context, this refers to having the “interface device” “simulat[e]” itself as a “virtual disk” to the “host” computer whose drivers the inventive interface device seeks to trigger and use for conducting data transfer. The “virtual files” and “virtual file system” refer to those files physically stored or kept on the “interface device,” a construction made more evident still by dependent claims that repeatedly describe these “virtual files” as “present” and “stored” on the “interface device.” Thus, as the dependent claims recite this specific aspect of the invention, the related independent claims must be broad enough to encompass it as well. The court’s construction to the contrary reflected a misunderstanding of the invention.

Fifth, and last, the court misconstrued “*second connecting device*,” holding that it requires a separate “physical socket or plug for permitting a user readily to attach and detach the ‘interface device’ with a plurality of dissimilar” DTRDs. As with its erroneous construction of “interface device,” the court’s construction lacks textual support in the claims and nothing in the specification requires restricting

this limitation to the particular “socket or plug” features disclosed therein. And as with its prior constructions, the court’s “physically separate” requirement for this term is inconsistent with its constructions of related claim terms (such as “interfacing”) that do not require any physical connection at all.

STATEMENT OF THE ISSUES

This appeal addresses the following claim construction errors that the district court committed in the course of granting summary judgment of noninfringement:

1. Did the court misconstrue the claim term “**interface device**” as limited to a physically separate, “stand-alone” device when (1) the claims do not recite this structural requirement, (2) the term “attached” does not require physical separateness between the “interface device” and DTRD under this Court’s precedent, and (3) the district court construed the related term “interfacing” as *not* requiring a physical connection?
2. Did the court misconstrue the claim term “**data transmit/receive device**” (**DTRD**) as a device that does not “transfer[] data to the ‘interface device’ *until* the ‘interface device’” has first connected with a “host” computer when (1) the claim text and specification do not specify when the DTRD transmits data to the “interface device,” (2) the court’s construction relied on the patents’ title, and (3) the court’s construction resulted in requiring a particular use for claims directed to an apparatus?
3. Did the court misconstrue an “**input/output device customary in a host device**” to mean a device physically installed “within the chassis of most ... computers” when the specification describes several embodiments of such “customary” devices (e.g., “printer devices”) located outside a computer chassis?
4. Did the court misconstrue “**virtual files**” and “**simulating a virtual file system**” to require files “not physically stored” on the “interface device” when (1) the intrinsic evidence describes these terms as files residing on the “virtual” hard-disk of the “interface device” that otherwise “*simulat[es]*” itself as a “virtual disk” to the “*host*” computer, and (2) the dependent claims recite having these “virtual files” “stored” and “present” on the “interface device”?
5. Did the court misconstrue “**second connecting device**” to require a separate “physical socket or plug for permitting a user readily to attach and detach the interface device with a plurality of” DTRDs when, as with “interface device,” the claim text and specification do not restrict this term to a particular structure?

STATEMENT OF THE CASE

I. THE PATENTS-IN-SUIT

U.S. Patent Nos. 6,470,399 (“the ’399 patent”) and 6,895,449 (“the ’449 patent”) are both entitled “Flexible Interface for Communication Between a Host and an Analog I/O Device Connected to the Interface Regardless of the Type of the I/O Device,” and share substantially identical specifications¹ and similar claim language. Michael Tasler is the sole named inventor for both patents, later acquired by Papst Licensing GmbH & Co. (Papst), the plaintiff-appellant.

A. Background of the Invention: Interface Devices and Drivers

Computers rely on successful interactions between hardware and software to properly function. These interactions between hardware and software are mediated by “drivers”—computer programs that allow hardware devices and software programs to communicate with each other.

With that backdrop, transferring data from an external hardware device (like a “data transmit/receive device,” or “DTRD”) onto a host computer likewise requires successful communication between that host computer and DTRD. This communication process is often mediated by an “interface device” that serves as a communications boundary for data transfer. The invention at issue relates to an

¹ Given the patents’ overlapping specifications, Papst provides representative citations to the ’399 patent.

interface device and its ability to more efficiently interact with a broad array of different hardware devices and computers.

In describing the invention, the patents-in-suit loosely adopt a tiered-approach to comparing and contrasting prior art interface devices with the claimed interface device. In that way, the patents demonstrate that the claimed interface device differs from the prior art by using the host computer’s drivers—an approach that yields superior outcomes, independent of any specific structural configuration.

1. Prior Art Interface Devices Suffered Undesirable Tradeoffs Between Flexibility Versus Speed

The specification describes prior art interfaces generally, noting their “compromises” between having “fast” or “high data-transfer rates” on the one hand, and flexibility (i.e., ability to interact with various devices) on the other.²

a. Prior Art Interface Devices

The patents’ Background section notes that such devices could acquire data from “data transmit/receive devices” that “cover the entire electrical engineering spectrum.”³ To illustrate this point, the specification provides “randomly chosen examples” to explain that interface devices have applications broadly ranging from “a diagnostic radiology system” to an “electronic measuring device” such as a

² A283 at 2:36-47.

³ A283 at 1:34-35.

multimeter.⁴ Given this need to put an interface device “to totally different uses,” the specification notes “[i]t is therefore desirable that an interface device be sufficiently flexible to permit attachment of very different electrical or electronic systems to a host device by means of the interface.”⁵

But as the patents’ Background section also teaches, such prior art interface devices faced drawbacks, too. The patents categorize these drawbacks into two groups based on their compromises between flexibility and speed, with one attribute generally requiring sacrifices in the other.

(1) **“Group 1” Interface Devices.** The first group of prior art interface devices had drivers that could be “used with a variety of host systems.”⁶ By using their own drivers, these prior-art interface devices could operate “largely independent of the host device,” but that advantage was offset by the need for “very sophisticated drivers” whose use resulted in slow data transfer speeds and frequent errors.⁷

(2) **“Group 2” Interface Devices.** The second group of prior art interface devices took an opposite approach, with opposite results. These devices

⁴ *Id.* at 1:55, 1:35-50.

⁵ *Id.* at 1:55-59.

⁶ *Id.* at 1:20-25.

⁷ *Id.* at 1:25-35.

used drivers specifically matched for individual host devices, resulting in faster data transfers. But that speed was offset by an inability to flexibly interact with different host devices.⁸

b. Prior Art Interface Devices Could Be Used in Specific Configurations for Specific Applications

The specification further describes prior art interface devices configured for use in specific applications. Two configurations are relevant to this appeal:

(1) “multi-tasking” configurations, and (2) “branched/parallel” configurations.

(1) “Multi-Tasking” Configuration (“Group 1” Example). Prior art interface devices used in “multi-tasking” systems could have “several different tasks such as data acquisition, data display and editing ... performed quasi-simultaneously.”⁹ In this configuration, the host computer and data transmit/receive device (DTRD) were simultaneously connected and could constantly communicate via the interface device. Problems arose, however, from having multiple drivers for the “different tasks” these systems would perform, creating the risk of “driver conflicts” that could “result in a system crash.”¹⁰ Thus, the multi-tasking benefits were offset by drawbacks with driver conflicts.

⁸ *Id.* at 1:65-2:14.

⁹ A283 at 2:47-50.

¹⁰ *Id.* at 2:50-63.

(2) **“Branched/Parallel” Configuration (“Group 2” Example).** The specification also cites European patent EP 0685799 as an example of a “branched” or *“parallel”* configuration.¹¹ In this configuration, “several peripheral devices” can be simultaneously attached to a single host device. This configuration was beneficial because multiple communications could then occur in parallel. But that benefit was offset by the need for “optimal matching between a host device and a specific peripheral device”¹²—i.e., a lack of flexibility.

2. The Claimed Interface Device Simultaneously Achieves Both Flexibility and Speed By Relying on Host Drivers

In light of the prior art, the Papst patents state “[i]t is an object of the present invention to provide an interface device for communication between a host device and a data transmit/receive device whose use is [1] host-device independent and [2] which delivers a high data transfer rate.”¹³ Thus, whereas prior art interface devices suffered problematic tradeoffs between flexibility versus speed, the patented interface device was designed to achieve the best of both worlds.

¹¹ A283 at 2:64 to A284 at 3:5.

¹² A284 at 3:4-5.

¹³ A284 at 3:24-28.

a. The Claimed Interface Device

To that end, the patents' Summary of the Invention emphasizes the invention's concept in using the host computer's drivers to avoid tradeoffs in flexibility versus speed: "The present invention is based on the finding that both a high data transfer rate and host device-independent use can be *achieved if a driver for an input/output device customary in a host device, normally present in most commercially available host devices, is utilized.*"¹⁴ Thus, the claimed interface device differs from prior art interface devices by using common drivers already installed in most host devices, instead of using the interface device's own drivers.

b. The Claimed Interface Device Can Be Used in Specific Configurations for Specific Applications

As the specification later notes, the solution of using the host computer's drivers can be implemented in the same prior-art configurations described above, including the "multi-tasking" and "branched/parallel" embodiments. The specification cites both as optional embodiments for the claimed interface device, illustrating that the invention achieves superior outcomes over the prior art, independent of any particular structural configuration or application. Each of those illustrative embodiments is described below.

¹⁴ A284 at 4:23-27.

(1) **“Multi-Tasking” Configuration (“Group 1” Comparison).** For “multi-tasking” applications, the specification describes an embodiment useful “for purposes of synchronizing data transfer from the data transmit/receive device to the interface device **10** and data transfer from the interface device **10** to the host device.”¹⁵ An advantage of this optional configuration is that an additional “data buffer can be implemented in the memory” of the interface device, which “guarantees error-free operation of the interface device **10** even for time-critical applications in multi-tasking host systems.”¹⁶ Thus, unlike error-*prone* prior art devices used in multi-tasking environments, the claimed invention is error-*free*.

(2) **“Branched/Parallel” Configuration (“Group 2” Comparison).** Further, the claimed interface device can be configured for simultaneously attaching several interface devices (and their corresponding DTRDs) to a single host device—i.e., for the “branched” or “parallel” configuration described above in the prior art, but without its drawbacks. In the section entitled “Detailed Description of Preferred Embodiments,” the patents thus tout an “enormous advantage” over prior art devices that share the same configuration:

¹⁵ A286 at 7:25-29.

¹⁶ A287 at 9:8-15.

In the interface device according to the present invention an enormous advantage is to be gained, as apparent in the embodiment described in the following as this **allows a plurality of dissimilar device types to be operated in parallel in identical manner**. Accordingly, **many** interface devices **10** can be connected to a host device which then sees **many** different “virtual” hard disks.¹⁷

Accordingly, whereas prior art interface devices in a “branched/parallel” configuration required specific matching between the host device and each attached device (or “branch”), an optional “embodiment” of the claimed invention permitted parallel attachment of many dissimilar devices, in an “identical manner.”

3. The Patents Describe Various Embodiments of the Claimed Invention to Demonstrate Its Overall Superiority—*Independent of Any Specific Structure or Use*

Ultimately, in comparing and contrasting the prior art, the asserted patents illustrate that the claimed invention outperformed prior art interface devices sharing the same configuration. As the patents indicate, that comparative advantage is independent of any specific structure or use, and “thus provides a universal solution which can cover the entire spectrum of possible data transmit/receive devices.”¹⁸

¹⁷ A286 at 8:23-31.

¹⁸ A288 at 12:38-40.

Comparison of the Prior Art and Claimed Interface Device to Illustrate the Superiority of the Claimed Interface Device Across All Contexts

Type of Configuration	Prior Art Interface Devices	Claimed Interface Device
Generally	Flexibility OR speed	Flexibility AND speed
Multi-Tasking Configuration	Error- prone due to driver conflicts	Error- free due to data buffer and host drivers
Branched/Parallel Configuration	Inflexible: requires device-specific matching	Flexible: allows identical parallel attachments

B. The Independent Claims Broadly Define the Interface Device Without Specifying Any Particular Structure or Use

Claim 1 of both patents is representative, and sets forth the invention’s basic architecture:

Claim 1: ’399 patent (A288-89)

1. An **interface device** for communication between a host device, which comprises drivers for **input/output devices customary in a host device** and a multi-purpose interface, and a data transmit/receive device, the **data transmit/receive device** being arranged for providing analog data, comprising:

- [1] a processor;
- [2] a memory;
- [3] a first connecting device for interfacing the host device with **the interface device** via the multi-purpose interface of the host device; and

- [4] a **second connecting device** for interfacing the **interface device** with the **data transmit/receive device**, the **second connecting device** including a sampling circuit for sampling the analog data provided by the **data transmit/receive device** and an analog-to-digital converter for converting data sampled by the sampling circuit into digital data,
- [A] wherein the **interface device** is configured by the processor and the memory to include a first command interpreter and a second command interpreter,
- [B] wherein the first command interpreter is configured in such a way that the command interpreter, when (1) receiving an inquiry from the host device as to a type of a device attached to the multi-purpose interface of the host device, (2) sends a signal, regardless of the type of the **data transmit/receive device** attached to the **second connecting device** of the interface device, to the host device which signals to the host device that it is **an input/output device customary in a host device**, (3) whereupon the host device communicates with the **interface device** by means of the driver for the **input/output device customary in a host device**, and
- [C] wherein the second command interpreter is configured to interpret a data request command from the host device to the type of input/output device signaled by the first command interpreter as a data transfer command for initiating a transfer of the digital data to the host device.

(Disputed claim language emphasized.)

Preamble. As indicated, the interface device acts as the “communication” boundary between a host device and a DTRD. The host device has pre-installed drivers for input/output devices customary in a host device, as well as a multi-purpose interface for connecting with various interface devices. The DTRD can provide analog data to the interface device.

Structural Elements [1]-[4]. As exemplified in Figure 1 (below), elements [1]-[4] of the claim then recite four components of the claimed interface device: a

processor (DSP); “memory,” “first connecting device” (1st CD), and “second connecting device” (2nd CD).

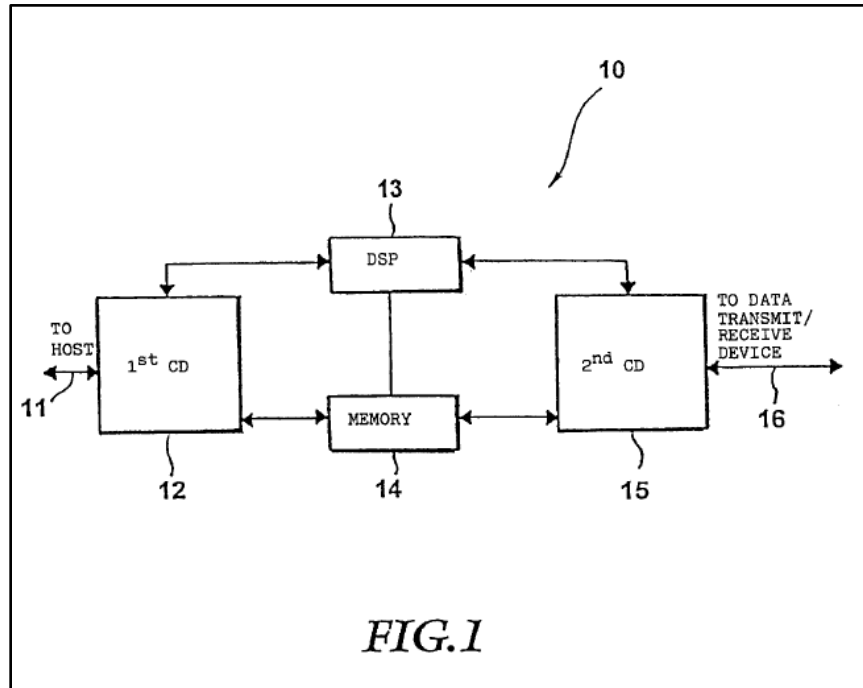

The device’s “first connecting device” interfaces with the host device, while the “second connecting device” interfaces with the DTRD. Because the DTRD provides analog data, the interface device’s “second connecting device” includes a “sampling circuit” and converter that collect and convert that analog data into digital data recognizable by the host computer.

“Wherein” Clauses [A]-[C]. The claim’s Wherein clauses [A]-[C] then recite how these four components operate.

Wherein clause [A] provides that the “processor” and “memory” configure the interface device to include both a first command interpreter and a second command interpreter that interpret commands issued by the host device.

Wherein clause [B] is the focus of the invention, and recites how the interface device convinces the host device to use its own drivers for data transfer. The clause explains that the interface device “(1) receiv[es] an inquiry from the host device” asking what type device is attached. The interface device responds by “(2) send[ing] a signal” telling the host computer that, “*regardless of the type of the data transmit/receive device attached*” to the interface device, the attached device is “an input/output device customary in a host device”—that is, a known device for which the host device *already* has drivers. Once this initial inquiry and response occur, from that point forward (“whereupon”) the “(3) host device communicates with the interface device by means of the driver for the input/output device customary in a host device.”

This crucial 3-step “conversation” described in Clause [B] can be summarized as follows:

- Step [B](1): HOST: “Who am I talking to?”**
- Step [B](2): INTERFACE DEVICE: “I’m a customary input/output device; you already have the necessary drivers installed.”**
- Step [B](3): HOST & INTERFACE DEVICE Agree: “OK, let’s use those drivers for data transfer.”**

Wherein clause [C] provides that these host-interface device communications occur via a “data request command” that the host computer issues

to the interface device. That “command” is then interpreted as a “data transfer command” for “initiating a transfer of the digital data to the host device.”

In sum, the claimed interface device operates by always identifying itself to the host device as a “customary” input/output device for which the host device already has drivers, and then using those drivers to transfer data onto the host.

Claim 1: '449 patent (A298)

Claim 1 of the '449 patent is similar. The primary difference is that instead of relying on “data request” and “data transfer” commands to initiate data transfer, the “interface device” in the '449 patent acts by “**simulating a virtual file system**” and “directory structure” to the host computer:

“wherein the interface device is arranged for **simulating a virtual file system** to the host, the virtual file system including a directory structure.”¹⁹

As with the '399 claim language, the '449 claims broadly recite the basic architecture of the claimed interface device, as well as the approach of “masquerading” as a customary input/output device to use the host computer’s pre-installed drivers. But the independent claims are otherwise silent—and thus impose no additional limitations—as to the device’s exact structural configuration; or exactly when it first communicates with the DTRD; or exactly what purpose it must be used for.

¹⁹ A298.

C. The Specification Discloses Various Ways in Which the Interface Device and Its Components May Be “Attached”

As noted above, Figure 1 of the patents illustrates an embodiment of the basic architecture for the claimed interface device. The specification describes this Figure and various ways in which components for the invention can be “attached”:

FIG. 1 shows a general block diagram of an interface device **10** according to the present invention. A first connecting device **12** of the interface device **10** can be attached to a host device (not shown) via a host line 11. The first connecting device is attached both to a digital signal processor **13** and to a memory means **14**. The digital signal processor **13** and the memory means **14** are also attached to a second connecting device **15** by means of bidirectional communication lines (shown for all lines by means of two directional arrows). The second connecting device can be attached by means of an output line 16 to a data transmit/receive device²⁰

Thus, the patent used the word “attached” to show that the interface device “can be” attached to the host device “via a host line,” and also “can be” attached to the DTRD using an “output line.” On the other hand, the interface device’s “first” and “second connecting device” are described as being attached to both the “processor” and “memory” using “bidirectional communications lines.” And more broadly, the components described in the embodiments by reference to Figures 1-2 are described as “attached” while being shown as part of the same structure.²¹ This

²⁰ A285 at 5:47-58.

²¹ *Id.*

varied usage is consistent with the non-limiting use of “attached” in the claims; both are devoid of any modifiers requiring a specific mode of attachment.

D. The Specification Discloses Various “Customary” Input/Output Devices That May Be Simulated By the Claimed Interface Device

The specification also highlights the claimed invention’s flexibility by noting its ability to simulate different “input/output devices customary in a host device,” whose drivers can then be used for data transfer:

Drivers for input/output devices customary in a host device which are found in practically all host devices are, *for example*, drivers for hard disks, for graphics devices or for printer devices. . . . [T]he hard disk driver is utilized in the preferred embodiment of the interface device of the present invention. Drivers for other storage devices such as floppy disk drives, CD-ROM drives or tape drives could also be utilized in order to implement the interface device according to the present invention.²²

Importantly, these exemplary “customary” input/output devices (such as printer devices, floppy disk drives, and CD-ROM drives) can be installed *outside* the host device.²³ This description of a wide range of “customary” I/O devices is consistent with the invention’s purpose: the more input/output devices that can be “simulated,” the more flexible the claimed interface device.

²² A284 at 4:27-39.

²³ A75 (“Those devices described are both inside and outside a computer.”).

E. The File History Confirms Patentability Did Not Turn on Any Specific Structural Configurations, Uses, or Types of Devices

Last, the prosecution histories confirm that the Patent Office never viewed any specific structures, uses, or type of input/output device as material to the patentability or operation of the claimed invention. Instead, the patentable advance was the invention’s novel and nonobvious use of host drivers to transfer data.²⁴

II. THE ACCUSED PRODUCTS

The majority of Defendants’ accused products are digital cameras that operate using the same claimed structures, in the same manner, as the patented invention. For example, the image sensor in the accused cameras is a “data transmit/receive device” that captures images in analog format and relays that data to the internal circuitry of the camera. The camera then functions as an “interface device” by sampling and converting those analog images into digital format, followed by additional image processing and eventual storage in the camera’s memory. The digital images remain there until the user transfers them by connecting the camera to the “host device,” e.g., the user’s personal computer.²⁵ The accused cameras operate similarly for audio and video data. An exemplary schematic illustrating an accused DTRD (the “CCD” image sensor, in green) and

²⁴ A468.

²⁵ A810 & A661-65.

interface device (components depicted in blue), housed together within the camera body, is depicted below:²⁶

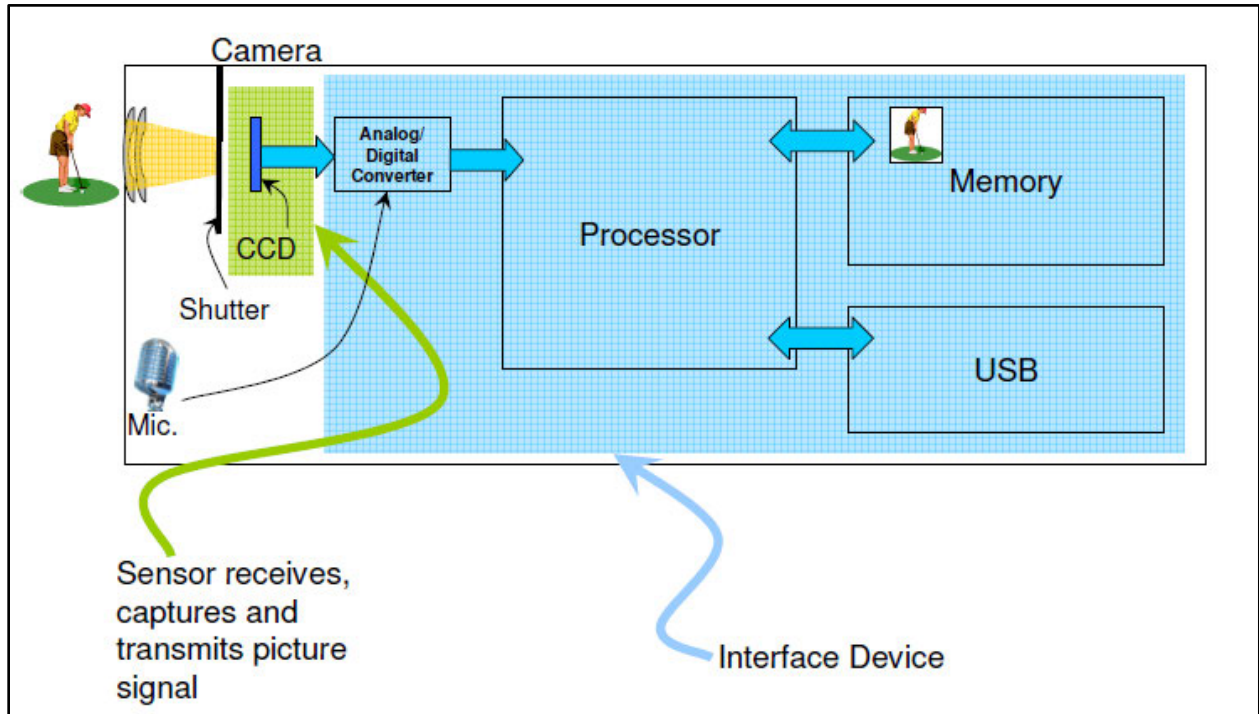

III. THE DISTRICT COURT PROCEEDINGS

A. Papst's History of Innovation and Licensing

Papst is a family owned, Germany-based licensing company founded by Georg Papst in 1992.²⁷ Before founding Papst, Georg Papst was co-owner and managing director of electric motor manufacturer Papst Motoren GmbH & Co. KG.²⁸ Papst Motoren was founded by Georg Papst's father, Hermann Papst, in 1952. Thereafter, Papst Motoren was sold to a company called Elektrobau

²⁶ A1423.

²⁷ <http://papstlicensing.com/#/corporate/history>.

²⁸ <http://papstlicensing.com/#/corporate/history/background>.

Mulfingen in 1992. Georg Papst, with his newly founded entity Papst Licensing, purchased Papst Motoren's entire patent portfolio of over 500 patents and patent applications.²⁹ Since then, Papst has managed and licensed the former Papst Motoren patent portfolio. Over time, Papst has built on its success in licensing that portfolio by working as a licensing entity for third-party patentees and, in some cases, by acquiring an interest in patents held by such third parties.³⁰

The inventor of the patents-in-suit, Mr. Tasler, is the founder of a small company for measuring systems based in Germany.³¹ Lacking the resources to enforce his invention rights against well-financed companies, he approached Papst and assigned the patents-in-suit to Papst on March 8, 2006.³²

B. Litigation Began After Unsuccessful Licensing Negotiations

Papst attempted to negotiate reasonable licenses with the Defendant Camera Manufacturers concerning their manufacture and sale of infringing devices. Those efforts were unsuccessful, and various lawsuits were brought by and against Papst, and then consolidated as a Multi-District Litigation.³³

²⁹ *Minebea Co. v. Papst*, 444 F. Supp. 2d 68, 78 (D.D.C. 2006).

³⁰ <http://papstlicensing.com/#/patents/model>.

³¹ A1416 at 15:8-20.

³² A1419-20.

³³ A513.

C. The District Court Narrowly Construed Several Claim Limitations and Granted Summary Judgment

The district court assigned to handle the MDL narrowly construed certain claim limitations while rendering several *Markman* and summary-judgment opinions. Specifically, the court first issued a *Markman* opinion in June 2009,³⁴ later modified its *Markman* rulings in November 2009,³⁵ and subsequently addressed these constructions again in various summary judgment opinions. Those opinions included the following five constructions:

Disputed Claim Limitation	District Court's Construction
“interface device”	Limited to a separate, stand-alone structure
“data transmit/receive device” (DTRD)	Limited to communicating with interface device only when host device is connected
“customary in a host device”	Limited to input/output devices physically installed inside the host computer's chassis
“virtual files”/“simulating a virtual file system”	Limited to files that do not physically exist on the interface device
“second connecting device” ³⁶	Limited to a physical plug or socket to permit ready attachment/removal of DTRDs

³⁴ A555 at Dkt No. 312.

³⁵ A18-98, published as *In re Papst Licensing GmbH & Co. KG Litig.*, 670 F. Supp. 2d 16 (D.D.C. 2009).

³⁶ Defendants sought summary judgment of noninfringement based on this “second connecting device” limitation, but the court denied it without prejudice. A203. Papst and Defendant Hewlett-Packard separately stipulated that certain HP products do not infringe under the district court's construction of “second connecting device.” A259-60. Accordingly, this construction remains a live dispute which Papst appeals in the interests of judicial economy.

The district court granted summary judgment of noninfringement based on its narrow constructions for the (1) “interface device,” (2) “DTRD,” (3) “input/output [storage] device customary in a host device,” and (4) “virtual files”/“simulating a virtual file system” limitations.³⁷ The court also ruled that Papst’s Final Infringement Contentions (FICs) did not properly reflect (or adopt) the district court’s narrow constructions,³⁸ issuing a “sanction” against prior counsel that limited Papst’s infringement allegations to those explicitly recited in its FICs.³⁹ Due to the “combined effect” of the court’s various rulings, it held all of the various accused products noninfringing.⁴⁰ The court thereafter agreed that Rule 54(b) certification was proper and entered Final Judgment.⁴¹

³⁷ A99-114 (“interface device”), published as *In re Papst Licensing GmbH & Co. KG Litig.*, 932 F. Supp. 2d 14 (D.D.C. 2013); A115-49 (“data transmit/receive device”); A150-175 (“input/output [storage] device customary in a host device”); A176-199 (“virtual files”/“simulating a virtual file system”).

³⁸ A204-18 (“Sanctions”), published as *In re Papst Licensing GmbH & Co. KG Litig.*, 273 F.R.D. 339 (D.D.C. 2011); A219-38 (“Wrongfully Accused Products”); A239-54 (“Table 15”); A255-71 (“Hewlett-Packard”).

³⁹ Papst has since retained new counsel for the present appeal and subsequent proceedings. Defendants moved for Section 285 fees against Papst, in amounts exceeding \$16 million. The district court denied Defendants’ motion without prejudice, indicating it will revisit the issue (if necessary) after Papst’s appeal. *See* A600-01.

⁴⁰ A273.

⁴¹ A278-79.

SUMMARY OF ARGUMENT

I. THE DISTRICT COURT REPEATED TWO FUNDAMENTAL CLAIM CONSTRUCTION ERRORS

A. The District Court Wrongly Construed the Claimed “Interface Device” as a Separate, Stand-Alone Structure

The district court’s first fundamental error broadly infected its construction of three claim limitations—“interface device,” “DTRD,” and “second connecting device.” The court’s foundational error in all three instances was in limiting the “interface device” to a separate, stand-alone structure that could not be located in the same housing as the “data transmit/receive device.” That construction is refuted by the intrinsic record, which uses broad and varied language to emphasize that the invention focuses on duping the host device into using its own drivers to conduct data transfer, and is *not* narrowly limited to any specific structural configuration. This Court’s precedents also firmly establish, as a general principle of patent law, that separately recited claim limitations do *not* require separate, stand-alone structures. The district court’s narrow constructions are thus contrary to the intrinsic record and this Court’s precedent, and must be reversed.

B. The District Court Wrongly Construed Single Words In Isolation, Divorced From Their Proper Context

The district court repeated another fundamental error in construing the remaining two limitations—“input/output device customary in a host device” and “virtual files”/“simulating a virtual file system.” In each instance, the district court

narrowly focused on construing a single word from each limitation—“in” and “virtual”—isolated from the full context provided by the surrounding claim language and overall specification. That flawed methodology produced constructions that contradicted the intrinsic evidence and excluded preferred embodiments, contrary to the analysis required by *Phillips*. Accordingly, these constructions must also be reversed.

STANDARD OF REVIEW

Claim construction is a question of law reviewed *de novo*.⁴² This Court also reviews *de novo* a district court’s grant of summary judgment.⁴³

⁴² *Cybor Corp. v. FAS Techs., Inc.*, 138 F.3d 1448, 1456 (Fed. Cir. 1998) (*en banc*).

⁴³ *Wyeth Holdings Corp. v. Sebelius*, 603 F.3d 1291, 1296 (Fed. Cir. 2010).

ARGUMENT

I. THE DISTRICT COURT ERRED IN CONSTRUING “INTERFACE DEVICE” TO REQUIRE A STAND-ALONE STRUCTURE

The central dispute concerns whether the “interface device” must necessarily exist as a stand-alone structure completely separate from the “data transmit/receive device” (Defendants’ position), or whether both devices can alternatively be located together in the same housing, such as a camera body (Papst’s position).

The district court construed “interface device” to require a completely separate stand-alone structure, removable from and located in a different housing from the “DTRD.”⁴⁴ That ruling is contrary to both the intrinsic record and this Court’s established rule that “the use of two terms in a claim requires that they connote different *meanings*, *not* that they necessarily refer to two different *structures*.”⁴⁵ Moreover, the claimed interface device is an “apparatus claim [that] recites a general structure without limiting that structure to a specific subset of structures,” and therefore must be construed to “cover all known types of that

⁴⁴ A33-41.

⁴⁵ *Applied Med. Res. Corp. v. U.S. Surgical Corp.*, 448 F.3d 1324, 1333 n.3 (Fed. Cir. 2006) (emphasis in original).

structure.”⁴⁶ The district court failed to apply these and other core principles in construing the claims, as explained below.

A. Papst’s Construction Is Correct Based on the Intrinsic Record and This Court’s Precedent

1. The Claims Do Not Include Language Limiting the “Interface Device” to a Separate Stand-Alone Structure

Both before and after this Court’s seminal *Phillips* decision, a patentee remains “free to choose a broad [claim] term and expect to obtain the full scope of its plain and ordinary meaning.”⁴⁷ Indeed, as this Court recently confirmed, claim terms carry their full and ordinary meaning absent a clear disclosure showing an intent to limit that meaning.⁴⁸ Here, the inventor chose broad terminology when defining the claimed invention. None of that broad language requires the structural separation that the district court required for the “interface device” limitation.

⁴⁶ *E.g.*, *CCS Fitness v. Brunswick Corp.*, 288 F.3d 1359, 1366 (Fed. Cir. 2002); *Plantronics, Inc. v. Aliph, Inc.*, 724 F.3d 1343, 1349-53 (Fed. Cir. 2013) (district court erred in limiting “stabilizer” terms to particular structures when claims were “drafted broadly, without bounds to any particular structure.”).

⁴⁷ *Thorner v. Sony Computer Entm’t Am. LLC*, 669 F.3d 1362, 1367 (Fed. Cir. 2012).

⁴⁸ *E.g.*, *Plantronics*, 724 F.3d at 1349-51; *Phillips v. AWH Corp.*, 415 F.3d 1303, 1312 (Fed. Cir. 2005) (*en banc*).

The plain meaning of “interface” is a “shared electrical boundary between parts of a computer system, through which information is conveyed.”⁴⁹ And a “device” is a “mechanism or piece of equipment designed to serve a purpose or perform a function.”⁵⁰ The ordinary meaning of “interface device” in the context of the patents-in-suit thus refers to a mechanism that serves as the communications boundary between the “host device” and the “data transmit/receive device.”

The use of the word “attached” in the claim language does not alter this conclusion. More specifically, the claim text recites having the “data transmit/receive device attached to . . . the interface device.” The district court relied on the use of “attached” as further signifying that the claimed “interface device” must exist as a stand-alone device, “completely” separate from the “DTRD.”⁵¹ But under this Court’s precedent, terms such as “attached” or “connected” are “general descriptive term[s] frequently used in patent drafting to reflect a functional relationship between claimed components,” and “[i]n the absence of modifiers, general descriptive terms are typically construed as having their full meaning.”⁵² Accordingly, this Court has held that terms like “attached”

⁴⁹ A613.

⁵⁰ A612.

⁵¹ A36.

⁵² *Innova/Pure Water, Inc. v. Safari Water Filtration Sys.*, 381 F.3d 1111, 1118 (Fed. Cir. 2004).

encompass the full range of possible associations between the recited claim elements—including internal and/or external attachment⁵³; direct and/or indirect linkages⁵⁴; permanent and/or removable attachment⁵⁵; and having structures attached within a single housing and/or physically separate housings.⁵⁶ That same broad understanding applies to the use of “attached” in the asserted claims, and nothing about the surrounding claim text (or specification) requires otherwise.

In other words, the broadly drafted claim language here contains no terms that, reasonably read, restrict the claimed “interface device” to a particular shape or structure—i.e., the “interface device” *may or may not* be physically separate from the “data transmit/receive device.” Had the inventor intended to specify the “stand-alone” structural separation imposed by the district court, he might have

⁵³ *Thorner*, 669 F.3d at 1367 (“The plain meaning of the term ‘attached’ encompasses either an external or internal attachment.”)

⁵⁴ *Douglas Dynamics, LLC v. Buyers Prods., Co.*, 717 F.3d 1336, 1342 (Fed. Cir. 2013) (noting that the “ordinary meaning of ‘connected to’ encompasses indirect linkages” as well as “a ‘direct’ connection.”).

⁵⁵ *See K-2 Corp. v. Salomon S.A.*, 191 F.3d 1356, 1363 (Fed. Cir. 1999) (noting that disputed claim language “speaks not at all . . . about whether that attachment is permanent, something less than permanent, or entirely removable.”).

⁵⁶ *See NTP, Inc. v. Research in Motion, Ltd.*, 418 F.3d 1282, 1310-11 (Fed. Cir. 2005) (“[T]wo components could be connected, joined, or linked together . . . and still be located in the same housing”); *see also Johnson Worldwide Assocs. v. Zebco Corp.*, 175 F.3d 985, 992 (Fed. Cir. 1999) (noting that “the unmodified term ‘coupled’ generically describes a connection, and does not require a mechanical or physical coupling”).

claimed (for example) that the “interface device” was “removably” attached,⁵⁷ but he did not. Because “the claim contains no limitations concerning *how* the device may be attached,”⁵⁸ the court erred in importing such limitations.

Accordingly, a skilled artisan would understand that the claimed “interface device” can be “attached” to the DTRD in any way, and that “it is unimportant how”⁵⁹ that attachment occurs.

2. Nothing in the Specification Limits the Claimed “Interface Device” to a Separate, Stand-Alone Structure

“Attached” is used in the specification consistent with this meaning. Indeed, consistent with this Court’s precedent, the description accompanying the embodiment described with reference to Figure 1 reflects a broad and varied use of

⁵⁷ See, e.g., *Ottah v. Verifone Sys.*, 524 Fed. Appx. 627, 629 (Fed. Cir. 2013) (noting “removable attachment” is “commonly understood” with a “widely accepted meaning”); *K-2 Corp.*, 191 F.3d at 1364 (construing “permanently affixed”); *Dorel Juvenile Group, Inc. v. Graco Children’s Prods.*, 429 F.3d 1043, 1045-46 (Fed. Cir. 2005) (construing “removably attached”).

⁵⁸ *Transmatic, Inc. v. Gulton Indus.*, 53 F.3d 1270, 1278 (Fed. Cir. 1995) (“[T]he district court erred by importing unnecessary functional limitations into the claim. . . . the claim contains no limitations concerning how the device may be attached to a vehicle.”).

⁵⁹ *In re Rasmussen*, 650 F.2d 1212, 1215 (C.C.P.A. 1981) (“[O]ne skilled in the art who read [the] specification would understand that it is unimportant *how* the layers are adhered, so long as they are adhered.”).

the words “attached” and “device” to convey that different “devices” can be “attached” in different ways, signaling again the breadth of those terms.⁶⁰

For example, the specification describes and depicts the “first” and “second” connecting devices as “attached” to the “memory” and “digital signal processor” of the interface device.⁶¹ There is no dispute that these four elements may be *permanently* “attached” to each other inside the *same* housing of the interface device. The “first connecting device” is also described as “attached” to the host device, and again there is no dispute this “first connecting device” can be *removably* attached within a *different* housing from the host. This varied usage of the word “attached” to describe connections between different “devices” supports a broad construction—not the narrow definition adopted by the district court.⁶²

Nor does the specification’s depiction of an interface device “attached” to the DTRD via a “line” in Figure 1 require structural separation. As explained below, “two components could be connected, joined, or linked together by wires or other electrical conductors and still be located in the same housing.”⁶³

⁶⁰ *Northern Telecom Ltd. v. Samsung Elecs. Co.*, 215 F.3d 1281, 1291 (Fed. Cir. 2000) (“[V]aried use of a disputed term in the written description demonstrates the breadth of the term rather than providing a limited definition.”).

⁶¹ A285.

⁶² *Northern Telecom*, 215 F.3d at 1291.

⁶³ *NTP*, 418 F.3d at 1310-11.

3. This Court Has Repeatedly Held That Separate Claim Elements Do *Not* Require Separate, Stand-Alone Structures

Fundamentally, Papst’s construction is correct as a principle of patent law, repeatedly articulated by this Court: “[T]he use of two terms in a claim requires that they connote different *meanings*, *not* that they necessarily refer to two different *structures*.”⁶⁴ The Court has applied this principle in several precedents, firmly establishing that separately recited devices are *not* limited to separate stand-alone structures.

NTP, Inc. v. Research in Motion, Ltd., 418 F.3d 1282 (Fed. Cir. 2005) is analogous and dispositive. There, like here, the *NTP* patent claims recited two different devices—an “RF receiver” and “destination processors”—that were “connected” for the “transfer” of information between them.⁶⁵ The specification also included the following statements:

- “The RF receiver automatically transfer[s] the information to the destination processor *upon connection* of the RF receiver to the destination processor.”
- “The RF receiver *may be detached* from the destination processor”⁶⁶

⁶⁴ *Applied Med. Res.*, 448 F.3d at 1333 n.3; *see also Intellectual Prop. Dev., Inc. v. UA-Columbia Cablevision of Westchester, Inc.*, 336 F.3d 1308, 1320 n.9 (Fed. Cir. 2003) (holding there was “no reason why, as a matter of law, one claim limitation may not be responsive to another merely because they are located in the same physical structure.”).

⁶⁵ *NTP*, 418 F.3d at 1309-10.

⁶⁶ *Id.*

And there, like here, the *NTP* patents included a block diagram depicting the “RF receiver” and “destination processor” as separate boxes connected by a line:⁶⁷

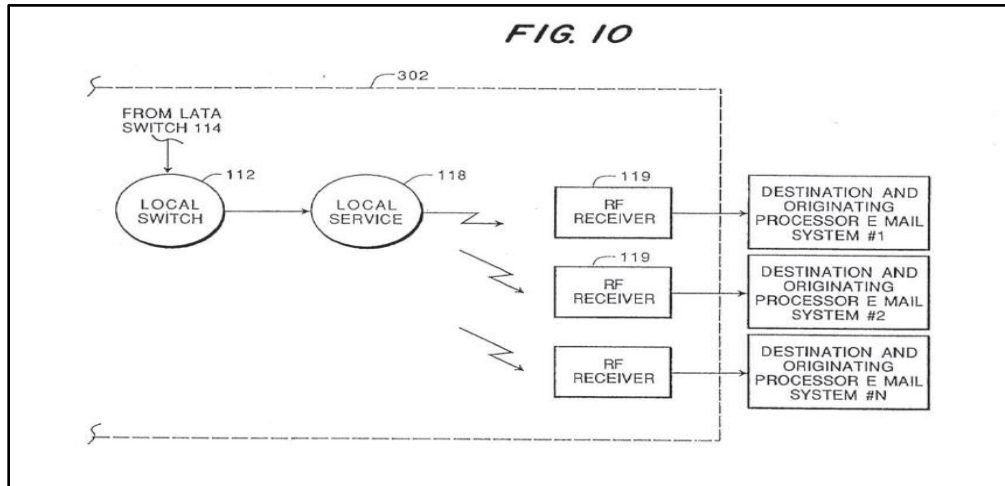

Applying longstanding principles of claim construction, this Court rejected the argument that the “RF receiver” and “destination processor” were different structures simply because they were recited as different limitations. Indeed, although the structures were described as “connected” and even possibly “detached,” this Court found the ordinary meaning of the claims did not require structural separation:

[I]t still does *not* require that the mobile processor and wireless receiver be physically disposed in separate housings. *A ‘connection’ can occur between these two devices regardless of whether they are housed separately or together.* Indeed, the two components could be connected, joined, or linked together by wires or other electrical conductors and *still be located in the same housing* or even on the same circuit board.”⁶⁸

⁶⁷ The same block diagram appears as Figure 10 in each of the five *NTP* patents.

⁶⁸ *Id.* at 1310-11.

The Court further rejected the notion that the “RF receiver” and “destination processor” required separate structures merely because they were used to “transfer” information between two places. Rather, it held that “a ‘transfer’ of information can equally occur between two entities that are physically housed together. The suggestion that information will be ‘*transferred*’ between these two entities does *not* require the *physical separation* of those entities.”⁶⁹

Those holdings are controlling here. As in *NTP*, the mere fact that the “interface device” and “data transmit/receive device” are recited in the claims and specification as “attached” or “connected” to send a “signal” for purposes of data “transfer” does *not* require their physical separation as stand-alone structures in different housings. *NTP* leaves no doubt that they may be physically disposed in the same housing, such as a camera body. This Court’s decisions following *NTP* confirm that conclusion:

- ***Linear Tech. Corp. v. ITC*, 566 F.3d 1049, 1055 (Fed. Cir. 2009)**—holding that separately recited “second circuit” and “third circuit” limitations did “not require entirely separate and distinct circuits,” because there was “nothing in the claim language or specification that supports narrowly construing the terms to require a specific structural requirement or entirely distinct ‘second’ and ‘third’ circuits.”

⁶⁹ *Id.* at 1310.

- ***Powell v. Home Depot, Inc.*, 663 F.3d 1221, 1231-32 (Fed. Cir. 2011)**—holding that a separately recited “cutting box” and “dust collection structure” “does not suggest that the claim terms require separate structures.” The Court also rejected the notion that those separate limitations required “wholly separate structures” simply because they were in “communication” with each other.
- ***Retractable Techs., Inc. v. Becton*, 653 F.3d 1296, 1303 (Fed. Cir. 2011)**—holding that separately recited “needle holder” and “retainer member” limitations “need not be separately molded pieces.”
- ***GE v. ITC*, 685 F.3d 1034, 1037 (Fed. Cir. 2012)**—holding that separately recited “inverter” and “shunt circuit” limitations did “not require that the inverter and shunt circuits are entirely separate,” and that the use of the word “coupled” did not “connote physical separation of the shunt circuit from the inverter.”

Papst’s construction is in accord with these precedents. The district court’s construction is not.

B. The District Court’s Construction of “Interface Device” Relied on Additional Errors

Indeed, in reaching its erroneous construction, the district court reasoned that the invention achieved the desired “flexibility” by acting as a stand-alone hardware structure to which “various kinds of data transmit/receive devices could be attached.”⁷⁰ But as described above, the invention achieves flexibility by its inventive measure of being able to interface with and convince a broad variety of *host* devices to use their own drivers. The court’s misunderstanding of this inventive point is reflected in the additional errors it relied on in construing “interface device.”

⁷⁰ A36.

1. The District Court Further Read “Attached” as Requiring the “Interface Device” *Not* Have “Permanent” Attachments

The district court further concluded that because the “interface device” and “DTRD” were “attached” to each other, they could not be a “permanent part” of a larger structure.⁷¹ But that conclusion is again refuted by this Court’s precedents interpreting “attached” and similar terms to include a full range of attachments—including structures permanently attached to each other.⁷²

2. The District Court Improperly Relied on the Specification’s Embodiments and Figures to Narrow the Claims

The district court also erroneously relied on its understanding of the patents’ embodiments and Figures—and what those Figures do *not* show—to limit the “interface device” to a separate, stand-alone structure.⁷³ This Court has repeatedly cautioned that claims are *not* limited to the embodiments or configurations depicted in the Figures, and for good reason.⁷⁴ This is true even when, as this Court

⁷¹ *Id.*

⁷² *See* Section I.A.1, *supra* (citing cases).

⁷³ A36 & A39; A103 & A108.

⁷⁴ *See, e.g., Arlington Indus. v. Bridgeport Fittings, Inc.*, 632 F.3d 1246, 1254 (Fed. Cir. 2011) (“[D]rawings in a patent need not illustrate the full scope of the invention.”); *MBO Labs., Inc. v. Becton, Dickinson & Co.*, 474 F.3d 1323, 1333 (Fed. Cir. 2007) (“[P]atent coverage is not necessarily limited to inventions that look like the ones in the figures.”); *Anchor Wall Sys. v. Rockwood Retaining Walls*, 340 F.3d 1298, 1306-07 (Fed. Cir. 2003) (“[T]he mere fact that the patent drawings

has held, “all” or “every” description in the specification shows the same particular feature.⁷⁵ “Of necessity, any depiction of any [invention] will necessarily show that [invention] arranged in a particular manner.”⁷⁶ Thus, “the fact that the patentee has not included figures depicting [the invention] from other orientations is not sufficient to limit the claim language to the particular orientation depicted in the figures.”⁷⁷ The district court’s reliance on the Figures to so limit the claims was again legal error.

The court’s analysis was also erroneous in view of precedent encouraging patentees to omit well-known subject matter from the specification and drawings. The court attached significance to the fact that only the claimed “interface device” was depicted in Figure 1, whereas “the data transmit/receive device is off the sheet,

depict a particular embodiment of the patent does not operate to limit the claims to that specific configuration.”).

⁷⁵ *E.g.*, *Acumed LLC v. Stryker Corp.*, 483 F.3d 800, 807 (Fed. Cir. 2007) (claim term not limited to particular structural feature despite “fact that **‘[e]very description** of the transverse holes in the ... patent contemplates” that feature because the “plain meaning of Claim 1 cover[ed] more than the particular embodiments shown in the figures.”); *MBO Labs.*, 474 F.3d at 1333 (court erred in limiting claim scope to particular structure even when specification’s figures **“all depict[ed]”** that feature); *Ventana Med. Sys. v. Biogenex Labs., Inc.*, 473 F.3d 1173, 1181-82 (Fed. Cir. 2006) (claim term not limited to feature disclosed in specification even though **“all of the ... patent’s disclosed embodiments employ[ed]”** that feature).

⁷⁶ *Agfa Corp. v. Creo Prods.*, 451 F.3d 1366, 1376-77 (Fed. Cir. 2006).

⁷⁷ *Lighting World, Inc. v. Birchwood Lighting, Inc.*, 382 F.3d 1354, 1365 (Fed. Cir. 2004).

out of sight, not part of the Figure, and not part of the invention,” to infer that the two devices were separate stand-alone structures.⁷⁸ But that conclusion misunderstands the patent and the proper role of patent specifications and drawings. “A patent need not teach, and preferably omits, what is well known in the art,”⁷⁹ and this Court has explained that “a patentee preferably omits from the disclosure any routine technology that is well known at the time of the application.”⁸⁰ The host devices and DTRDs here were indisputably routine, well-known technologies; again, the invention’s patentable advance concerned the interface device and its clever use of the host computer’s drivers. Thus, the district court erred in inferring that the absence of a detailed depiction of the DTRD in Figure 1—a figure only used to illustrate the preferred embodiments—required structural separation. That inference erroneously penalized the inventor’s efficient depiction of the claimed invention.⁸¹

⁷⁸ A39.

⁷⁹ *Spectra-Physics, Inc. v. Coherent, Inc.*, 827 F.2d 1524, 1534 (Fed. Cir. 1987).

⁸⁰ *Chiron Corp. v. Genentech, Inc.*, 363 F.3d 1247, 1254 (Fed. Cir. 2004).

⁸¹ *See, e.g., Advanced Fiber Techs. Trust v. J&L Fiber Servs.*, 674 F.3d 1365, 1375 (Fed. Cir. 2012) (“[A]s a general matter, brevity in a patent disclosure should be applauded, not impugned.”).

3. The District Court Misread Statements Regarding “Desirable” Flexibility to Narrow the Claims

The district court’s construction also erroneously relied on the specification’s statement that “[i]t is therefore desirable that an interface device be sufficiently *flexible* to permit attachment of very different electrical or electronic systems [i.e., DTRDs] to a host device by means of the interface.”⁸² Statements that describe a feature as “desirable” are alone insufficient to strictly limit claims to embodiments with that attribute.⁸³

Moreover, the court’s reasoning reflects a misunderstanding of the claimed invention and the nature of the flexibility described in the patents and the “desirable” advantages it conferred over the prior art concerning “flexibility.” As described above, the advantageous flexibility of the claimed interface device was its ability to interact with various host devices (“host device independence”)⁸⁴ and to use that host device’s own *drivers* to transfer data. The invention was *not* defined by its ability to flexibly attach various data transmit/receive devices achieved through the use of adaptable *hardware* in the second connecting device.

⁸² A37.

⁸³ *Acumed*, 483 F.3d at 805 (“Stryker’s argument is essentially an assertion that since the patent says broaching is desirable, the term ‘curved’ must be construed to cover only embodiments whose curvature allows them to be inserted into a broached hole . . . That assertion is flawed: it is an attempt to import a feature from a preferred embodiment into the claims.”).

⁸⁴ A284 at 3:28 & 4:24 & 5:30-32.

4. The District Court Misinterpreted the “Enormous Advantage” Discussion to Narrow the Claims

Similarly, the district court misinterpreted statements in the specification concerning the “enormous advantage” of “the present invention” to infer that “interface device” was limited to a stand-alone structure.⁸⁵

First, that specification passage makes clear that, as part of the Detailed Description of Preferred Embodiments, the “enormous advantage” language is referring to an optional “*embodiment*” in which the ability for multiple parallel connections “*can be*” implemented.⁸⁶ This Court has further made clear that describing embodiments using “permissive language” (such as “may” or “can be”) to describe the invention’s potential benefits is a “far cry” from the necessary disavowal required to limit claims to that embodiment.⁸⁷ The law is also clear that mere references to possible embodiments do not limit claim scope.⁸⁸

⁸⁵ See A286 at 8:23-31; A37-38.

⁸⁶ *Id.*

⁸⁷ See *i4i Ltd. P’ship v. Microsoft Corp.*, 598 F.3d 831, 844 (Fed. Cir. 2010) (“The specification’s permissive language, ‘could be edited,’ ‘can be created,’ and ‘ability to work,’ does not clearly disclaim systems lacking these benefits.”); *Advanced Fiber Techs.*, 674 F.3d at 1375 (“[T]he specification states only that the openings in the backing plate ‘may be punched or drilled,’ a far cry from strictly limiting the invention to devices formed solely by piercing or puncturing.”).

⁸⁸ See, e.g., *Laitram Corp. v. Cambridge Wire Cloth Co.*, 863 F.2d 855, 865 (Fed. Cir. 1988) (“References to a preferred embodiment, such as those often present in a specification, are not claim limitations.”).

Second, the law is equally clear that merely describing “advantages” does not require limiting claims to embodiments that always achieve those advantages.⁸⁹ “[T]he fact that a patent asserts that an invention achieves several objectives does not require that each of the claims be limited to structures that are capable of achieving all of the objectives.”⁹⁰

Third, and importantly, the district court misinterpreted the substance of what this embodiment actually describes. Contrary to the court’s analysis, this passage does *not* describe the interface device as a single stand-alone structure that flexibly connects with a variety of DTRDs. Rather, as set forth earlier, the description of “a plurality of dissimilar device types to be operated in *parallel*” describes a “branched” configuration in which a single host device is simultaneously connected to *many* different interface devices and their attached DTRDs, *at the same time*, in the same way that many different power cords and

⁸⁹ *Phillips*, 415 F.3d at 1327 (“Although deflecting projectiles is one of the advantages of the baffles of the ’798 patent, the patent does not require that [baffles] always be capable of performing that function.”);

⁹⁰ *Id.*; *see also i4i*, 598 F.3d at 843 (“[N]ot every benefit flowing from an invention is a claim limitation.”); *E-Pass Techs., Inc. v. 3COM Corp.*, 343 F.3d 1364, 1370 (Fed. Cir. 2003) (“An invention may possess a number of advantages or purposes, and there is no requirement that every claim directed to that invention be limited to encompass all of them.”); *Golight, Inc. v. Wal-Mart Stores, Inc.*, 355 F.3d 1327, 1331 (Fed. Cir. 2004) (“[P]atentees [are] not required to include within each of their claims all of [the] advantages or features described as significant or important in the written description.”).

their attached electrical devices can be plugged into a power strip.⁹¹ Indeed, this Court’s precedent makes clear that “parallel” has a well-known meaning in the electrical arts signifying the simultaneous operation of many devices at once⁹²; it has *nothing* to do with a structure being separate or “stand-alone.” Thus, the court misread this “branched/parallel” embodiment as requiring a stand-alone structure.

5. The District Court Improperly Relied on the Patents’ “Title” to Narrow the Claims

The district court even relied on the patents’ “title of the invention” to narrow the scope of the recited “interface device” to a physically separate structure, noting this title described the “interface device” and “DTRD” as “connected” to each other.⁹³ But a patent’s title is irrelevant to claim construction; instead, “the purpose of the title is not to demarcate the precise boundaries of the

⁹¹ See A286 at 8:23-33.

⁹² See *Inpro II Licensing, S.A.R.L. v. T-Mobile USA, Inc.*, 450 F.3d 1350, 1353 n.2 (Fed. Cir. 2006) (“‘Parallel’ communication involves the simultaneous transmission of information over separate paths.”); *Power-One, Inc. v. Artesyn Techs., Inc.*, 599 F.3d 1343, 1347 (Fed. Cir. 2010) (“A parallel bus . . . utilizes multiple communication paths, sending out parallel information streams.”); *Fifth Generation Computer Corp. v. IBM*, 416 Fed. Appx. 74, 75 (Fed. Cir. 2011) (“Parallel computing systems seek to increase their speed and processing power by employing multiple computer processors that operate simultaneously.”).

⁹³ A36-37; A109.

claimed invention but rather to provide a useful reference tool for future classification purposes” such as “indexing, classifying, and searching, etc.”⁹⁴

6. The District Court’s Construction for “Interface Device” Conflicts With Its Broader Construction for “Interfacing”

Tellingly, the court’s construction of “interface device” is also irreconcilable with its construction of the related term, “interfacing.”⁹⁵ Specifically, while the district court based much of its summary judgment rationale on this “physically separate” requirement for “interface device,” the court nevertheless construed “interfacing” as *not* requiring a physical connection, more broadly interpreting it to mean “for establishing communication.”⁹⁶ Thus, the court held that the “interface device” *must* be a physically separate structure, physically “attached” to a separate DTRD; but also that the device’s function of “interfacing” with the DTRD need *not* have a physical connection between the interface device and DTRD. These inconsistent constructions further highlight the need for reversal.⁹⁷

⁹⁴ *Pitney Bowes, Inc. v. Hewlett-Packard Co.*, 182 F.3d 1298, 1312 (Fed. Cir. 1999).

⁹⁵ A94.

⁹⁶ *Id.*; *see also* A50-51.

⁹⁷ *E.g., Rexnord Corp. v. Laitram Corp.*, 274 F.3d 1336, 1342 (Fed. Cir. 2001) (“[A] claim term should be construed consistently with its appearance in other places in the same claim or in other claims of the same patent.”); *AIA Eng’g Ltd. v. Magotteaux Int’l S/A*, 657 F.3d 1264, 1276 (Fed. Cir. 2011) (“We strive, where possible, to avoid nonsensical results in construing claim language.”).

II. THE DISTRICT COURT MISCONSTRUED “DATA TRANSMIT/RECEIVE DEVICE”

The district court construed “data transmit/receive device” (DTRD) to require that it “does not transmit data to the interface device *until* the interface device is connected to the [host] computer.”⁹⁸ The construction thus excluded transmissions between the DTRD and interface device *before* the interface device connects with the host computer. At the outset, that construction is erroneous because it presumes that these recited devices must be physically separate from each other in the first instance and are thereafter connected.⁹⁹ *See* Argument Section I, *supra*. Further, it relies on the additional errors explained below.

A. Papst’s Construction Is Correct Under the Intrinsic Record

1. The Claim Language Allows Data Transfer Between the DTRD and Interface Device, Without Need for Any Further Connection to a Host Device

The claims are silent about exactly when the DTRD transmits data to the interface device, and otherwise say nothing about requiring that this transmission occur only upon the connection of all three recited devices (DTRD—interface device—host computer). Claim 1 of the ’399 patent only specifies that the DTRD is “arranged to provide analog data to the interface device,” which is then capable

⁹⁸ A121.

⁹⁹ *Id.*

of sampling and converting that analog data into digital format.¹⁰⁰ There is simply no temporal or sequential claim language indicating this process only occurs *after* the interface device connects with the host computer. The absence of such limiting language thus points again to a construction that permits communication between the DTRD and interface device at *any* time, before or after the interface device connects with the host device.

To be sure, the claims do recite temporal limitations when describing communications between the interface device and host device. Specifically, the claims specify that “**when**” (after) the host computer asks about the type of device it is communicating with, the interface device sends a signal indicating it is a “customary” input/output device, “**whereupon**” (after which point) the host and interface devices agree to communicate using the host device’s drivers. This deliberate usage of sequential language to describe communications between the host and interface devices, coupled with the absence of such language to describe communications between the interface device and DTRD, further supports a construction that the DTRD can communicate with the interface at any time.¹⁰¹

¹⁰⁰ See A288-89.

¹⁰¹ *Acumed*, 483 F.3d at 807-08 (rejecting narrow construction where the specification indicated “the patentees knew how to restrict their claim coverage” using certain language, but chose different language in drafting the claims).

Additionally, the language of “wherein” clause [C] of claim 1 implicitly supports Papst’s position that the DTRD-interface device data transfer can occur *before* the interface device connects with the host device. That clause indicates that in response to a “data request command” issued by the host device, the interface device responds by “initiating a transfer of the *digital* data to the host device.” The modifier “digital” strongly implies that by this time, the DTRD’s analog data has already been transmitted and converted into digital format and stored in memory on the interface device. At minimum, the claims do not preclude this alternative, and thus a proper construction cannot exclude it.¹⁰²

2. The Specification Supports This “DTRD” Construction

The specification is in accord. It describes, for example, the interface device as capable of long-term storage of digital data in its recited memory *before* connecting to the host device.¹⁰³ Thus, the DTRD could transfer data to the interface device and the data could remain there unless and until the interface thereafter connects with host computer. After all, that is one of the purposes of the

¹⁰² *3M Innovative Props. Co. v. Tredegar Corp.*, 725 F.3d 1315, 1331 (Fed. Cir. 2013) (“Our cases emphasize that an alternative means of accomplishing the claimed result weighs against a claim construction that would exclude that alternative.”).

¹⁰³ *See, e.g.*, A285 at 5:6-9 (“The interface device according to the present invention therefore simulates, both in terms of hardware and software, the way in which a conventional input/output device functions, preferably that of a hard disk drive”).

claimed “memory” structure in the interface device.¹⁰⁴ But the district court’s construction effectively renders that memory capacity unnecessary, transforming it from a memory component that stores data into a conduit that merely *streams* data.

B. The District Court’s Construction is Erroneous

In addition to disregarding the absence of limiting claim text and the specification, the district court’s “DTRD” construction relied on additional errors.

First, it apparently relied on an understanding that communication between the host computer, interface device, and DTRD *must* occur in the same chronological order as the enumerated “*first*” and “*second*” connecting devices. Specifically, the court misunderstood the claims to require that the “first” communication had to occur between the host computer and interface device (via the “first connecting device”); and only afterwards could a “second” communication occur between the interface device and DTRD (via the “second connecting device”) to initiate data transfer:

Data does not begin to be sent from the data transmit/receive device to the interface device *until* the [host] computer and interface device have established communication [via the first connecting device]; *only then* does the second command interpreter begin to “transfer data from the data transmit receive device via the second connecting device” where analog data is sampled and converted to digital data.¹⁰⁵

¹⁰⁴ A286 at 7:50-55.

¹⁰⁵ A61 & A121.

But this Court’s precedent makes clear that, as used here, the modifiers “first” and “second” do *not* impose an order or sequence requirement—instead, “the use of the terms ‘first’ and ‘second’ is a common patent-law convention to distinguish between repeated instances of an element or limitation.”¹⁰⁶ The court seemingly failed to recognize this rule.

Second, the district court’s construction requires that all three devices—host device, interface device, and DTRD—be simultaneously connected before the DTRD can transmit data onto the interface device. But as it did with its “interface device” construction, the court impermissibly relied on the patents’ title to deduce that unstated requirement.¹⁰⁷

Third, the scenario required by the district court—simultaneous connection and communication between the host device, DTRD, and interface device—is essentially an optional embodiment used for “multi-tasking” applications, the structure for which is covered by a *dependent claim*.¹⁰⁸ The specification notes the

¹⁰⁶ *3M Innovative Props. Co. v. Avery Dennison Corp.*, 350 F.3d 1365, 1371 (Fed. Cir. 2003); *Gillette Co. v. Energizer Holdings, Inc.*, 405 F.3d 1367, 1373 (Fed. Cir. 2005).

¹⁰⁷ A122; *Pitney Bowes*, 182 F.3d at 1312.

¹⁰⁸ A283 at 2:47-51 (describing “multi-tasking systems in which several different tasks such as data acquisition, data display and editing are to be performed quasi-simultaneously”).

interface device can *optionally* be configured for this purpose, and that this embodiment relies on additional structure (a “data buffer”) to guarantee error-free operation of the interface device.¹⁰⁹ Such an embodiment, however, is covered by *dependent claim 3*, which recites the “data buffer” used for multi-tasking.¹¹⁰ The court’s construction thus conflated the scope of the *independent* claims with an optional embodiment separately covered by a *dependent* claim, against this Court’s precedent permitting a patentee to “draft different claims to cover different embodiments.”¹¹¹ In short, the district court’s DTRD construction runs afoul of the claim-differentiation doctrine.

Fourth, the court’s construction improperly limits *device* claims to a specific use. But “it is well-settled that device claims are not limited to devices which operate precisely as the embodiments described in detail in the patent.”¹¹² In other words, claims directed to a device encompass all structures that meet the claim

¹⁰⁹ A287 at 9:10-15 (noting “a data buffer can be implemented in the memory means **14** . . . This guarantees error-free operation of the interface device **10** even for time-critical applications in multi-tasking host systems.”).

¹¹⁰ A289, claim 3: (“An interface device according to claim 1, wherein the memory means comprises a buffer to buffer data to be transferred between the data transmit/receive device and the host device.”).

¹¹¹ *Intamin, Ltd. v. Magnetar Techs., Corp.*, 483 F.3d 1328, 1337 (Fed. Cir. 2007); *Helmsderfer v. Bobrick Washroom Equip., Inc.*, 527 F.3d 1379, 1383 (Fed. Cir. 2008) (“It is often the case that different claims are directed to and cover different disclosed embodiments.”).

¹¹² *Virginia Panel Corp. v. MAC Panel Co.*, 133 F.3d 860, 866 (Fed. Cir. 1997).

elements, regardless of use.¹¹³ Here, the specification makes clear that multi-tasking is a specific application useful where simultaneous data acquisition and display are desirable. But there is no *requirement* that such an invention be used for that specific purpose. “[T]he fact that the inventor anticipated that the invention may be used in a particular manner does not limit the scope to that narrow context,”¹¹⁴ and apparatus claims should not be construed “in a way that makes direct infringement turn on the use to which an accused apparatus is later put.”¹¹⁵ In requiring particular steps or manner of use, the court’s “DTRD” construction violates these principles, and must be reversed.

III. THE DISTRICT COURT MISCONSTRUED “INPUT/OUTPUT [STORAGE] DEVICE CUSTOMARY IN A HOST DEVICE”

As indicated earlier, the claimed invention tricks the host computer into believing it is communicating with a “customary” input/output device so that the host computer will use its own drivers. The parties’ dispute on this limitation concerns whether the “customary” input/output device itself must be physically

¹¹³ See *Paragon Solutions, LLC v. Timex Corp.*, 566 F.3d 1075, 1091 (Fed. Cir. 2009) (“Absent an express limitation to the contrary, *any* use of a device that meets all of the limitations of an apparatus claim written in structural terms infringes that apparatus claim.”).

¹¹⁴ *Brookhill-Wilk 1, LLC v. Intuitive Surgical, Inc.*, 334 F.3d 1294, 1301 (Fed. Cir. 2003).

¹¹⁵ *Paragon Solutions*, 566 F.3d at 1091.

installed inside the host computer (Defendants' position), or whether they can also include devices not physically within the host computer (Papst's position).

The district court agreed with Defendants and construed "input/output [storage] device customary in a host device" to require that the I/O device itself be physically installed "within the chassis of most commercially available computers at the time of the invention."¹¹⁶ The court reached that construction by construing a single word in isolation—"in"—rather than the entire limitation. Properly read, the patents make clear that the interface device simulates a broad range of such "customary" I/O devices, irrespective of their installation inside *or outside* the host.

A. Papst's Construction Is Correct Under the Intrinsic Record

1. The Specification Discloses Several "Customary" Input/Output Devices That Can Be *Externally* Installed

The district court's construction is contrary to the patents' specification, the "[u]sually dispositive" and "single best guide to the meaning of a disputed term."¹¹⁷ Indeed, it is "dispositive" as to the construction of this "customary" limitation. Immediately after identifying the core idea behind the invention—namely, that both high data-transfer rates ("speed") and host-device independence

¹¹⁶ A95.

¹¹⁷ *Phillips*, 415 F.3d at 1315 (citation omitted).

(“flexibility”) can be achieved using the host computer’s drivers for “an input/output device customary in a host device” to conduct data transfer—the patents’ Summary of Invention lists examples of “customary” input/output devices:

Drivers for input/output devices customary in a host device which are found in practically all host devices are, *for example*, drivers for hard disks, for graphics devices or for printer devices. . . . Drivers for other storage devices such as floppy disk drives, CD-ROM drives or tape drives could also be utilized in order to implement the interface device according to the present invention.¹¹⁸

Thus, the specification states the interface device can simulate a wide range of I/O “devices customary in a host device,” including hard disks, graphic devices, printer devices, CD-ROM drives, and/or tape drives—some or all of which can be installed *outside* a computer. The parties agree that printers are installed *outside* a computer,¹¹⁹ and that the other exemplary devices listed may be installed either inside *or outside* the host computer.¹²⁰ Accordingly, Papst’s construction properly reflects the specification’s varied list of such exemplary embodiments identified in the specification. The court’s construction excludes them—an outcome which is “rarely, if ever, correct.”¹²¹

¹¹⁸ A284 at 4:27-39.

¹¹⁹ A75 (“The parties agree that printers are not inside a computer.”).

¹²⁰ *Id.* (“Those devices described are both inside and outside a computer.”).

¹²¹ *E.g., Rambus Inc. v. Rea*, 731 F.3d 1248, 1253 (Fed. Cir. 2013) (“A claim construction that excludes the preferred embodiment is rarely, if ever, correct and would require highly persuasive evidentiary support.”); *Medrad, Inc. v. MRI*

2. The District Court Erred By Construing “In” Rather Than “Input/Output Device Customary In a Host Device”

The district court’s analysis did the opposite of what *Phillips* requires.

Although the court recognized that the specification discloses examples of I/O devices that could be installed outside the host device, it resolved the dispute by focusing on what it believed to be the ordinary meaning of “in”—rather than construing the entire limitation, “input/output devices customary in a host device.” The court’s *Markman* opinion plainly reveals that it asked and answered the wrong question:

[Q]: “The question [is]—what does ‘in’ a host device mean?”¹²²

[A]: “[T]he word ‘in’ should be construed in accordance with its ordinary meaning to mean ‘within,’ not ‘with respect to’ as Papst proposes.”¹²³

But “[e]xtracting a single word from a claim divorced from the surrounding limitations can lead construction astray.”¹²⁴ That is precisely what happened here. The specification made clear that “input/output devices customary in a host device” included a wide array of exemplary devices that could be installed outside

Devices Corp., 401 F.3d 1313, 1320 (Fed. Cir. 2005) (“A claim construction that does not encompass a disclosed embodiment is . . . rarely, if ever, correct.”).

¹²² A74.

¹²³ A75.

¹²⁴ *IGT v. Bally Gaming Int’l, Inc.*, 659 F.3d 1109, 1117 (Fed. Cir. 2011).

the chassis of a host computer. But the district court excluded those embodiments by narrowly focusing on the meaning of a single word, “in,” and elevating it over the contrary teachings of the specification.

Even assuming *arguendo* it was acceptable to interpret “in” divorced from the intrinsic record, the district court *still* answered that question incorrectly, because the ordinary meaning of “in” is not narrowly limited to physical location inside a housing or chassis. For example, keyboards (like printers) are customary devices in computers, but are located outside the computer. Spare tires and radio antennas are customary features in automobiles, but are not necessarily inside the body of the vehicle. The court’s erroneous construction simply disregarded this context and ordinary meaning.

IV. THE DISTRICT COURT ERRED IN CONSTRUING “VIRTUAL FILES” AND “SIMULATING A VIRTUAL FILE SYSTEM”

For the ’449 patent, the district court construed “virtual files” and “simulating a virtual file system” to require files that are “not physically stored” on the interface device.¹²⁵ But it reached that conclusion by again relying on a dictionary definition, divorced from the claims and specification.

¹²⁵ A97.

A. Papst's Construction Is Supported by the Intrinsic Record

1. The Specification Indicates the "Virtual Files" and "Virtual File System" Reside on the "Virtual Hard Disk"

The specification repeatedly emphasizes that the preferred embodiment involves a "virtual hard disk," whereby the interface device identifies itself to the host computer as a hard disk, and then uses the host computer's drivers to transfer data. In this embodiment, the "virtual files" and "virtual file system" are simply the files and file directory stored on the interface device. The specification is replete with statements supporting this conclusion:

- "The interface device according to the present invention therefore **simulates, both in terms of hardware and software**, the way in which a conventional input/output device functions, preferably that of a **hard disk drive**."¹²⁶
- "Preferably, the interface device according to the present invention **simulates a hard disk** with a root **directory** whose entries are '**virtual files**'"¹²⁷
- "The **simulation** of a freely definable **file structure on the 'virtual' hard disk** provides simple operation and expansion options"¹²⁸
- "In reply to an instruction from the host device to display the directory of the '**virtual' hard disk drive simulated by the interface device 10**"¹²⁹

¹²⁶ A285 at 5:5-9.

¹²⁷ *Id.* at 6:1-3.

¹²⁸ A288 at 12:29-31.

¹²⁹ A285 at 6:35-38.

Thus, a skilled artisan would understand that the terms “virtual files” and “virtual file system” refer to the files and file system residing on the virtual hard disk implementation of the claimed invention.

2. The Claims Confirm That “Virtual Files” and the “Virtual File System” Are Physically Stored on the Interface Device

Under *Phillips*, “[o]ther claims of the patent in question, both asserted and unasserted, can also be valuable sources of enlightenment as to the meaning of a claim term,” because “claim terms are normally used consistently throughout the patent.”¹³⁰ Here, that principle reinforces the conclusion that the “virtual files” and the “virtual file system” refer to those files physically “present” on the interface device when it acts or “simulat[es]” itself as a “virtual” hard disk to the “host device” attached to it. Specifically, the plain language of dependent claims 7-10 of the ’399 patent confirms the physical presence of the “virtual files” and “virtual file system” on the interface device:

- 7. An interface device according to claim 2, which further comprises a root directory and **virtual files** which are **present on the signaled hard disk drive . . .**
- 8. An interface device according to claim 7, wherein the **virtual files** comprise a configuration file in text format which are **stored in the memory means . . .**

¹³⁰*Phillips*, 415 F.3d at 1314.

- 9. An interface device according to claim 7, wherein the **virtual files** comprise batch files or executable files for the microprocessor means which are **stored in the interface device . . .**
- 10. An interface device according to claim 7, wherein the **virtual files** comprise batch files or executable files for the host device which are **stored in the interface device.**

Read together, the claims and specification demonstrate that simulating a “virtual hard disk” is the preferred embodiment, and the “virtual files” and “virtual file system” are the files and directory stored on the interface device when the claimed interface device is simulating a “virtual hard disk.”

B. Defendants’ Construction Is Contrary to the Intrinsic Record

The district court’s analysis was flawed in both methodology and outcome.

1. The District Court Erred By Construing “Virtual” Instead of “Virtual Files” and “Simulating a Virtual File System”

The court repeated the same fundamental error here that it made when construing “customary in a host device”—it focused on dictionary definitions addressed to “virtual” instead of construing the disputed limitations in their entirety, as informed by the specification. The court’s *Markman* opinion makes clear that it reached its construction by mixing and matching dictionary definitions

for “virtual record” and “virtual,” and then replacing the word “record” with “file.”¹³¹

But again, this approach contradicts *Phillips*. When construing claims, “the context of the surrounding words of the claim also must be considered,”¹³² because courts do “not interpret claim terms in a vacuum, devoid of the context of the claim as a whole.”¹³³ “While dictionaries and treatises are useful resources in determining the ordinary and customary meaning . . . of disputed claim terms, the correct meaning of a word or phrase is informed only by considering the surrounding text.”¹³⁴

Additionally, the court ignored important indicators that an extrinsic dictionary definition of “virtual” was inappropriate here. The specification repeatedly uses “virtual” set off by quotation marks, a drafting convention commonly employed to signal that dictionary definitions should *not* govern the

¹³¹ A83-85.

¹³² *ACTV v. Walt Disney Co.*, 346 F.3d 1082, 1088 (Fed. Cir. 2003).

¹³³ *Kyocera Wireless Corp. v. ITC*, 545 F.3d 1340, 1347 (Fed. Cir. 2008).

¹³⁴ *Brookhill-Wilk 1*, 334 F.3d at 1301. *See also IGT*, 659 F.3d at 1117 (“Extracting a single word from a claim divorced from the surrounding limitations can lead construction astray.”).

analysis and that instead the specification should be consulted as the relevant dictionary for determining claim scope:¹³⁵

- “Preferably, the interface device according to the present invention simulates a hard disk with a root directory whose entries are ‘**virtual**’ files”¹³⁶
- “In reply to an instruction from the host device to display the directory of the ‘**virtual**’ hard disk drive simulated by the interface device”¹³⁷
- “[I]t is possible that the FAT is not read until immediately prior to reading or storing the data of the ‘**virtual**’ hard disk”¹³⁸
- “[M]any interface devices **10** can be connected to a host device which then sees many different ‘**virtual**’ hard disks.”¹³⁹

Accordingly, the district court erroneously relied on an extrinsic dictionary definition, divorced from the context and particular meaning in the claims and specification.

¹³⁵ *Sinorgchem Co. v. ITC*, 511 F.3d 1132, 1136 (Fed. Cir. 2007) (“The term ‘controlled amount’ is set off by quotation marks—often a strong indication that what follows is a definition.”); *United States v. Korpan*, 237 F.2d 676, 679-80 (7th Cir. 1956) (“[T]he use of quotation marks to set off the word ‘slot’ indicates that Congress did not intend the language . . . to be as comprehensive as the dictionary definition of ‘slot machine.’”).

¹³⁶ A285 at 6:1-3.

¹³⁷ *Id.* at 6:35-38.

¹³⁸ *Id.* at 6:45-47.

¹³⁹ A286 at 8:31-33.

2. The District Court’s Construction Renders the Dependent Claims Inconsistent with the Independent Claims

The error in the district court’s construction is also evident from the fact that it renders a plain reading of the claims logically inconsistent. Whereas dependent claims 7-10 make clear that the “virtual files” are physically “present” and “stored” on the “interface device,” the court’s construction simultaneously precludes their physical presence and storage on the “interface device,” creating another inconsistency—further evidence that the court’s construction is incorrect.

3. The District Court’s Construction Renders Dependent Claims Impermissibly Broader Than Independent Claims

The court’s interpretation of “virtual” not only requires a logically inconsistent reading of dependent claims 7-10, it also introduces a *legal* impossibility, by rendering a dependent claim impermissibly *broader* than its independent claim.

Specifically, the final “wherein” clause of independent claim 1 of the ’449 patent recites “simulating a virtual file system to the host, the virtual file system including a directory structure.”¹⁴⁰ Dependent claim 2, in turn, specifies that the “directory structure” includes virtual files “stored in the memory” of the interface device. But the court’s construction creates a legal conflict: “simulating a virtual

¹⁴⁰ A288-89.

file system” in independent claim 1 *excludes* physical storage on the interface device, while the plain language of dependent claim 2 indicates that the virtual file system has a directory structure that *includes* such physical storage on the interface device. This outcome thus violates the axiomatic prohibition that “a dependent claim cannot be broader than the claim from which it depends.”¹⁴¹

V. THE COURT MISCONSTRUED “SECOND CONNECTING DEVICE”

Last, the district court construed “second connecting device” to require a “physical socket or plug for permitting a user readily to attach and detach the interface device with a plurality of dissimilar data transmit/receive devices.”¹⁴² As before, this construction was infected by the court’s misguided belief that the “interface device” and “data transmit/receive device” were separate stand-alone structures. Because that foundational premise is incorrect, the court’s resulting construction is also incorrect, and must be reversed.¹⁴³

¹⁴¹ *Alcon Research, Ltd. v. Apotex Inc.*, 687 F.3d 1362, 1367 (Fed. Cir. 2012).

¹⁴² A94.

¹⁴³ The district court denied Defendants’ “second connecting device” summary judgment motion without prejudice. A200-03. The proper construction of “second connecting device” remains a live dispute that can be addressed on appeal. *See, e.g., Advanced Software Design Corp. v. Fiserv, Inc.*, 641 F.3d 1368, 1378 (Fed. Cir. 2011) (“Although the court’s construction did not play a role in the summary judgment of noninfringement, Advanced Software has raised the issue on appeal Because this issue may become important during the proceedings on remand, we address it now in the interest of judicial economy.”).

First, as noted above, the plain meaning of “device” here does not require a separate structure; rather, the word only signifies something “designed to serve a purpose or perform a function.”¹⁴⁴ The stated purpose or function of the “second connecting device” is to communicate with the DTRD using the “sampling circuit” and “analog-to-digital converter.”¹⁴⁵ Neither a “physical plug or socket” nor the ability to readily add and remove a “plurality of dissimilar data transmit/receive devices” are required by the claims or specification. The relevant “flexibility” achieved by the invention arises from its general use of the host computer’s drivers to perform data transfer irrespective of the specific host device (“host device independence”). The invention was *not* a hardware solution that achieved flexibility by attaching and removing different DTRDs via a plug or socket. The court wrongly viewed the invention through a hardware lens, and grafted extraneous hardware limitations unsupported by the intrinsic record.

Second, the court’s construction for “second connecting device” is logically inconsistent with its constructions for immediately adjacent claim language. Specifically, the claims recite a “**second connecting device for interfacing**” the interface device and DTRD. The district court construed “interfacing” as requiring only establishing communication, and rejected Defendants’ attempt to import a

¹⁴⁴ A612.

¹⁴⁵ The ’449 patent lacks such limitations.

“physical connection” requirement.¹⁴⁶ But the result of that decision is the simultaneous juxtaposition of a “second connecting device” that *requires* a “physical plug or socket,” to perform the stated function for “interfacing” that does *not* require a physical connection. This incoherent and nonsensical result should be “viewed with extreme skepticism,”¹⁴⁷ and reversed.

VI. THE DISTRICT COURT’S RULINGS MUST BE VACATED IN VIEW OF THE PROPER CLAIM CONSTRUCTIONS

The district court granted summary judgment of noninfringement based on its narrow constructions for (1) “interface device,”¹⁴⁸ (2) “data transmit/receive device,”¹⁴⁹ (3) “input/output [storage] device customary in a host device,”¹⁵⁰ and (4) “virtual files”/“simulating a virtual file system.”¹⁵¹ Those rulings must be vacated in view of the correct claim constructions, which would permit a reasonable jury to find infringement of each disputed limitation. The incorrect construction for (5) “second connecting device” should be reversed and remanded as well. Last, as the district court restricted (or “sanctioned”) Papst and granted

¹⁴⁶ A50-51.

¹⁴⁷ *See, e.g., AIA Eng’g*, 657 F.3d at 1276 (“We strive, where possible, to avoid nonsensical results in construing claim language.”).

¹⁴⁸ A114-15.

¹⁴⁹ A148-49.

¹⁵⁰ A174-75.

¹⁵¹ A199.

partial summary judgment based in part on alleged failures in Papst's Final Infringement Contentions to properly apply the court's (incorrect) constructions,¹⁵² those adverse rulings should also be vacated.

CONCLUSION

For the foregoing reasons, the judgment against Papst should be vacated and remanded.

¹⁵² See A217-18 (Sanctions); A238 (Wrongfully Accused Products); A254 (Table 15); A270-71 (Hewlett-Packard).

Dated: February 20, 2014

Respectfully submitted,

/s/ John T. Battaglia

Alan M. Fisch

R. William Sigler

John T. Battaglia

Thomas C. Chen

FISCH HOFFMAN SIGLER LLP

5335 Wisconsin Avenue NW

Eighth Floor

Washington, DC 20015

(202) 362-3500

*Attorneys for Plaintiff-Appellant
Papst Licensing GmbH & Co. KG*

ADDENDUM

UNITED STATES DISTRICT COURT
FOR THE DISTRICT OF COLUMBIA

**IN RE PAPST LICENSING GMBH & CO. KG
LITIGATION**

Misc. Action No. 07-493 (RMC)

MDL Docket No. 1880

This Document Relates To:

The First Wave Cases --

Fujifilm Corp. v. Papst, 07-cv-1118;
Matsushita Elec. Indus. Co., Ltd. v. Papst, 07-cv-1222;
Papst v. Olympus Corp., 07-cv-2086;
Papst v. Samsung Techwin Co., 07-cv-2088;
Papst v. Ricoh Co. Ltd., 07-cv-612;
Hewlett Packard Co. v. Papst, 08-cv-865; and
Papst v. Nikon Corp., 08-cv-985.

MODIFIED MEMORANDUM OPINION REGARDING CLAIMS CONSTRUCTION

Papst Licensing GMBH & Co. (“Papst”) acquired two patents from inventor Michael Tasler and in this MDL has alleged that digital camera manufacturers that sell products in the United States have infringed its patents. Pursuant to *Markman v. Westview Instruments, Inc.*, 517 U.S. 370 (1996), the Court is required to construe the contested claims of the patents before a jury can determine whether the accused products infringe.

I. BACKGROUND

A. Procedural History

Papst alleges that the Camera Manufacturers¹ (also referred to as “CMs”) infringe

¹ This Opinion relates to the First Wave Cases listed in the caption. The Camera Manufacturers who are parties in the First Wave Cases include: Fujifilm Corporation; Fujifilm U.S.A., Inc.; Fujifilm Japan; Matsushita Electric Industrial Co., Ltd.; Victor Company of Japan, Ltd.; Olympus Corporation; Olympus Imaging America Inc.; Samsung Techwin Co.; Samsung Opto-Electronics America, Inc.; Panasonic Corporation of North America; JVC Company of America; Ricoh Corporation; Ricoh

two patents: U.S. Patent Nos. 6,470,399 (“ ’399 Patent”) and 6,895,449 (“ ’449 Patent”) (collectively the “Patents”). The Court held a claims construction hearing on September 22 through 24, 2008, with the benefit of extensive briefing and arguments by Papst and the Camera Manufacturers.² For purposes of this MDL, Papst is treated as the plaintiff regardless of how any individual lawsuit originated in its home court.

The Court issued its Memorandum Opinion Regarding Claims Construction on June 12, 2009. Papst filed a Request for Clarification and Reconsideration of Part of the Court’s Order Regarding Claims Construction on July 13, 2009. *See* Dkt. # 321. This Modified Opinion grants the request for reconsideration. For ease of future review, if any, it contains the full opinion in a single document and the June 12, 2009, Memorandum Opinion and Order [Dkt. ## 312 & 313] will be vacated.

B. Facts

Papst is a German company, whose business is to acquire and enforce intellectual property rights. That is, it acquires patents on products or methods invented by others and then searches the world for products it might challenge for infringement. When faced with such a challenge, the allegedly infringing party chooses whether (1) to enter into a licensing agreement and pay royalties to Papst or (2) to take part in patent infringement litigation, either as a defendant in an

Company Ltd.; Ricoh Americas Corporation; Hewlett-Packard Company; Nikon Corporation; and Nikon, Inc.

² The parties’ briefs include: Papst’s *Markman* Br. [Dkt. # 173]; CMs’ *Markman* Br. [Dkt. # 188]; Papst’s Reply [Dkt. # 193]; and CMs’ Surreply [Dkt. # 197]; Papst’s Mot. for Reconsideration [Dkt. # 321]; CMs’ Opp’n [Dkt. # 323]; Papst’s Reply to its Mot. for Reconsideration [Dkt. #325]; CMs’ Surreply [Dkt. # 328]; and Papst’s Resp. to Surreply [Dkt. # 330]. Citations to the transcript of the *Markman* hearing are identified as “Tr. day #:page # (Party),” with days 1, 2, and 3 representing the transcripts of September 22, 23, and 24, 2008, respectively.

infringement suit seeking damages filed by Papst or as a plaintiff in a suit seeking declaratory judgment of non-infringement against Papst. In this case, Papst acquired certain rights to the Patents from the inventor, Michael Tasler. Papst then sought to negotiate license agreements with manufacturers of digital cameras all over the world. When numerous manufacturers who sell digital cameras in the United States refused to enter licensing agreements with Papst, Papst and the manufacturers filed lawsuits against one another and this MDL ensued.

The invention at issue is a “Flexible Interface for Communication Between a Host and an Analog I/O Device Connected to the Interface Regardless of the Type of the I/O Device.” ’399 Patent, Title; ’449 Patent, Title (lower case substituted). “In this title I/O means input/output device,” Tr. 1:6 (Papst), but the I/O device is repeatedly referred to as a “data transmit/receive device” in the Patents. *See, e.g.*, ’399 Patent, col. 13:1-2 & col. 3:43-44 (stating “regardless of the type of the data transmit/receive device attached”); ’449 Patent, col. 11:63-64 & col. 4:6-7 (same). The invention was designed to provide fast data communication between an analog I/O device and a digital computer (“host device”) by converting the analog data to digital, formatting it, and transferring the data to the computer without the need for special software; this was accomplished by telling the computer that the invented interface device was an I/O device already known to the computer (and for which the computer already had drivers), regardless of what kind of data transmit/receive device was attached to the interface device. ’399 Patent, Abstract; ’449 Patent, Abstract. When the computer responded with a data request command, the interface device interpreted the command as a data transfer request and forwarded the digitized data originating from the analog data transmit/receive device. ’399 Patent, col. 13:9-13.³ “It is *the* object of the present

³ The ’449 Patent Claims contain no similar provision expressing the transfer of data from the data transmit/receive device through the interface device and to the computer. *See* ’449 Patent,

invention to provide an interface device for communication between a host device [computer] and a data transmit/receive device whose use is host device-independent and which delivers a high data transfer rate.” ’449 Patent, col. 3:20-23 (emphasis added); *see* ’399 Patent, col. 3:24-27 (“It is an object of the present invention to provide an interface device for communication between a host device and a data transmit/receive device whose use is host device-independent and which delivers a high data transfer rate.”).

The ’399 Patent was issued on October 22, 2002, with an application date of March 3, 1998; the ’449 Patent was issued on May 17, 2005, with an application date of August 15, 2002. As of March 1998, when Mr. Tasler applied for the ’399 Patent, “interface devices themselves were known but they had certain problems. . . . [T]o get these prior art interface devices to talk to computers, they required these sophisticated drivers which were prone to malfunction and had poor data transfer rates.” Tr. 1:5 (Papst).⁴ Another problem with the prior art was that “if you start[ed] installing specific drivers for each piece of hardware that you add[ed] to the computer, these drivers [could] start butting heads with each other . . . [and] [t]he computer crashe[d].” *Id.* 1:6 (Papst). Drivers “are the software programs that are used by the computer[] to communicate with the hardware that’s attached to the computer. So for each and every hardware device that you connect to a computer there has to be a driver that allows the computer to communicate with that hardware device. So when you attach[ed] these prior art interface devices, we [had] drivers that caused

col. 12:1-7 (after the interface device signals that it is a customary storage device, the computer “communicates with the interface device by means of the driver for the storage device customary” in the computer and the interface device simulates a “virtual file system” to the computer); *but see id.*, col. 4:55-61 (the ’449 Patent specification mimics the specification for the ’399 Patent in describing data transfer).

⁴ The Court here provides Papst’s explanation of prior art to explain the invention, but the Court is not making any findings concerning the prior art.

problems.” Tr. 1:5 (Papst). However, all kinds of computers could “communicate with . . . very common hardware devices such as hard disk drives” and printers. *Id.* 1:7 (Papst). “The present invention is based on the finding that both a high data transfer rate and host device-independent use can be achieved if a driver for an input/output device customary in a host device, normally present in most commercially available host devices, is utilized,” instead of special driver software. ’399 Patent, col. 4:23-27; *see also* ’449 Patent, col. 3:27-30 (same).

[T]o make his invention flexible [Mr. Tasler sought] to simulate one of these customary devices [such as the hard disk drive already on the computer] and be able to communicate with the computer with the language that it already knew and to in fact configure the data to simulate files and file systems that the computers would expect to see, [making the communication between the device and the computer] faster and more reliable.

He also saw that by not writing drivers, specific drivers for his own interface device and instead causing the computer to use the drivers that were supplied by the computer makers that he would achieve a more reliable invention, a more reliable data communication and in fact, the drivers for certain of these devices such as the disk drives were highly optimized for each operating system so they worked very well and transferred data at a very fast rate compared to the drivers for the known interface devices.

Also he made it easier to hook one of these up. He put into the interface device the ability to respond to an inquiry from a computer and generate a response that would cause the computer to recognize it as a piece of hardware that [the computer] already knew about and then by doing that [the interface device] allowed the computer to install, recognize and install the interface device without any input from the person who is using the computer [because no special driver was needed].

Tr. 1:7-8 (Papst).

To illustrate the nature of the invention at the claims construction hearing, Papst showed a “prototype board” (an integrated circuit board) and “matched up” the devices on the prototype board “that corresponded with some of the things that are shown” in Figure 2 of each Patent. *Id.* 1:11 (Papst); *see also id.* 1:19-20 (Papst). “[T]he circuit board itself was designed by Mr. Tasler,” *id.* 1:13 (Papst), meaning that Mr. Tasler himself selected and arranged the configuration and connections between the parts on the circuit board. *Id.* 1:13-14 (Papst). Papst noted calibration relays on the right side of the board, suggesting the inputs, amplifiers, and sample and hold circuits in Figure 2, where the interface device would be connected to the data transmit/receive device. *Id.* 1:11 (Papst). The prototype board also had a digital signal processor, an EEPROM (electrically erasable programable read only memory) chip for non-volatile memory, and volatile random access memory (RAM). *Id.* Volatile memory is no longer retained when the computer is turned off, while non-volatile memory remains. Tr. 3:138 (Papst). In addition, a small computer system interface (SCSI) chip was on the prototype board where the interface device would be connected to the computer, in order to “generate[] the signals that actually communicate with the computer.” *Id.* Under the ’399 Patent, the interface device was designed to “receive analog data and convert it to digital data and put it in a form that [could] be transferred to the host computer.” *Id.* 1:21-22 (Papst). Digitizing analog data was insufficient by itself; the interface device was also designed to achieve “formatting it into a proper file, put[ting] it in a file system that the host computer [could] recognize,” because, otherwise, “the standard driver, disk driver for a computer would not be able to use that digital information.” *Id.* 1:22 (Papst). The ’449 Patent does not “recite that the interface device has to receive analog data,” *id.* 1:21 (Papst), but “[w]ith respect to the [’]399 Patent, the Patent [O]ffice thought they were patenting an interface device that received analog data and processed it and provided it to a host computer. And that’s what the claims covered.” *Id.* 1:25

(Papst).

The '399 and '449 Patents share the same drawings and much of the same specification. The '449 Patent is a "continuation or divisional" patent that covers other aspects of the invention and that "claims priority back to the 399 Patent." *Id.* 1:27, 30 (Papst). The '449 Patent omits references to analog-to-digital conversion but "add[s] in the requirement that when it responds to the inquiry command [from the computer], [the interface device] identifies itself as a storage device." *Id.* 1:29 (Papst).

"[T]he interface device . . . is configured by the processor and the memory. That certainly suggests some software." *Id.* 1:30 (Papst). In addition, the '399 Patent references a "first command interpreter" and a "second command interpreter," both of which are "configured." *Id.* 1:31 (Papst). Thus, at the *Markman* hearing, Papst asserted that the Patents have aspects of both a hardware patent and a software patent. *Id.*; *but see* Papst's *Markman* Br. at 2 (stating that the interface device, "in the context of [the] patents-in-suit, is a hardware device that serves as a bridge between a computer . . . and a data device that acquires or transmits data").

The first Claim of each Patent contains most of the terms that need to be construed.

Claim One of the '399 Patent states:

What is claimed is:

1. An interface device for communication between a host device, which comprises drivers for input/output devices customary in a host device and a multi-purpose interface, and a data transmit/receive device, the data transmit/receive device being arranged for providing analog data, comprising:

a processor;

a memory;

a first connecting device for interfacing the host device with the

interface device via the multi-purpose interface of the host device;
and

a second connecting device for interfacing the interface device with the data transmit/receive device, the second connecting device including a sampling circuit for sampling the analog data provided by the data transmit/receive device and an analog-to-digital converter for converting data sampled by the sampling circuit into digital data,

wherein the interface device is configured by the processor and the memory to include a first command interpreter and a second command interpreter,

wherein the first command interpreter is configured in such a way that the command interpreter, when receiving an inquiry from the host device as to a type of a device attached to the multi-purpose interface of the host device, sends a signal, regardless of the type of the data transmit/receive device attached to the second connecting device of the interface device, to the host device which signals to the host device that it is an input/output device customary in a host device, whereupon the host device communicates with the interface device by means of the driver for the input/output device customary in a host device, and

wherein the second command interpreter is configured to interpret a data request command from the host device to the type of input/output device signaled by the first command interpreter as a data transfer command for initiating a transfer of the digital data to the host device.

'399 Patent, col. 12:41-67 & col. 13:1-13.

Claim One of the '449 Patent states:

What is claimed is:

1. An interface device for communication between a host device, which comprises drivers for input/output devices customary in a host device and a multi-purpose interface, and a data transmit/receive device comprising the following features:

a processor;

a memory;

a first connecting device for interfacing the host device with the interface device via the multi-purpose interface of the host device; and

a second connecting device for interfacing the interface device with the data transmit/receive device,

wherein the interface device is configured by the processor and the memory in such a way that the interface device, when receiving an inquiry from the host device as to the type of a device attached to the multi-purpose interface of the host device, sends a signal, regardless of the type of the data transmit/receive device attached to the second connecting device of the interface device, to the host device which signals to the host device that it is a storage device customary in a host device, whereupon the host device communicates with the interface device by means of the driver for the storage device customary in a host device, and

wherein the interface device is arranged for simulating a virtual file system to the host, the virtual file system including a directory structure.

'449 Patent, col. 11:45-67 & col. 12:1-6.

II. LEGAL STANDARDS

A. Claims Construction Principles Generally

The “claims” of a patent are those descriptions of the invention that are numbered and follow the introductory phrase, “[w]hat is claimed.” An understanding of a patented invention must start and end with the claims themselves which identify and distinguish the inventor’s invention. To determine whether a patent claim has been infringed, a court must undertake a two-step process. The court first construes or interprets each contested claim, or phrase or word within a claim, to determine its meaning and scope; only afterward are the claims compared to the accused device(s). *O.I. Corp. v. Teckmar Co. Inc.*, 115 F.3d 1576, 1580 (Fed. Cir. 1997). This litigation is at the first stage of this process.

The interpretation of patent claims is exclusively a question of law. *Markman*, 517 U.S. 370. In claims construction, a court must interpret the words of each contested claim from the perspective of one skilled in the art at the time of invention, in light of the patent documents and the prosecution history. *Phillips v. AWH Corp.*, 415 F.3d 1303, 1313 (Fed. Cir. 2005). Words in the claims of a patent are given their ordinary and customary meaning, that is, the meaning that the term would have had to a person of ordinary skill in the pertinent art at the time of the invention. *Id.* at 1312-13. “[T]he ‘ordinary meaning’ of a claim term is its meaning to the ordinary artisan after reading the entire patent.” *Id.* at 1314. Although words are generally given their ordinary meaning, “a patentee may choose to be his own lexicographer and use terms in a manner other than their ordinary meaning, as long as the special definition of the term is clearly stated in the patent specification or file history.” *Vitronics Corp. v. Conceptronics Inc.*, 90 F.3d 1576, 1582 (Fed. Cir. 1996). When a specification expressly defines terms or defines terms by implication, the specification will be held to limit the claims accordingly. *Phillips*, 415 F.3d at 1321. *Phillips* discredited the approach of prior cases holding that claim terms were to be given the broadest possible ordinary meaning and that the specification should only be consulted for a clear disavowal of such meaning. *Id.* at 1319-21. The *Phillips* court reasoned that this approach resulted in unduly expansive claim construction and improperly restricted the role of the specification in claim construction. *Id.* (disavowing *Texas Digital Systems, Inc. v. Telegenix, Inc.*, 308 F.3d 1193 (Fed. Cir. 2002) and cases following its approach).

Claim construction should be undertaken independent of any consideration of how the claims may or may not be read on the accused product. *SRI Int’l v. Matsushita Elec. Corp. of Am.*, 775 F.2d 1107, 1118 (Fed. Cir. 1985). “[C]laims are not construed to ‘cover’ or ‘not to cover’

the accused device. That procedure would make infringement a matter of judicial whim.” *Id.*; see also *Wilson Sporting Goods Co. v. Hillerich & Bradsby Co.*, 442 F.3d 1322, 1326-27 (Fed. Cir. 2006) (the court should not prejudge the infringement analysis by construing claims with an aim to include or exclude a particular product, but knowledge of the accused product is helpful to provide context and focus).

In construing a claim, a court starts with the intrinsic evidence of its meaning—the claims, the specification, and the prosecution history. *Vitronics*, 90 F.3d at 1582; see *Pitney Bowes Inc. v. Hewlett-Packard Co.*, 182 F.3d 1298, 1305 (Fed. Cir. 1999) (the starting point for claim interpretation must be the claims themselves). The “prosecution history” of a patent is the complete public record of the proceeding before the U.S. Patent and Trademark Office (“PTO”). *Phillips*, 415 F.3d at 1317. The public record includes the original application and any claim amendments and explanations made by the applicant. *Vitronics*, 90 F.3d 1582. For example, a patent applicant may limit claims during prosecution by modifying claim language to overcome examiner rejection, by distinguishing a reference, or by disavowing claim coverage. *Omega Eng’g Inc. v. Raytek Corp.*, 334 F.3d 1314, 1323-25 (Fed. Cir. 2003). The specification of a patent “must include a written description of the invention or discovery and of the manner and process of making and using the same, and is required to be in such full, clear, concise, and exact terms as to enable any person skilled in the art or science . . . to make and use the same.” PTO Rules § 1.71(a). “The specification must set forth the precise invention . . . in such a manner as to distinguish it from other inventions and from what is old.” *Id.* § 1.71(b). The specification is the “single best guide to the meaning of a disputed term.” *Vitronics*, 90 F.3d 1582.

The Federal Circuit has recognized a fine line between reading a claim *in light of the*

specification and reading *a limitation into a claim* from the specification. *Phillips*, 415 F.3d at 1323. The former is appropriate and necessary; the latter constitutes error. *Id.* For example, a discussion in a specification of a particular embodiment of an invention does not normally confine the invention to that particular embodiment. *Id.* (citing *Nazomi Comm., Inc. v. ARM Holdings, PLC*, 403 F.3d 1364, 1369 (Fed. Cir. 2005)). “To avoid importing limitations from the specification into the claims, it is important to keep in mind that the purposes of the specification are to teach and enable those of skill in the art to make and use the invention and to provide a best mode for doing so.” *Id.* at 1323. Usually the specification clearly states whether it is setting out specific examples of the invention or whether the patentee intends the embodiments in the specification to be coextensive with the claims. *Id.* A court does not improperly read a limitation into a claim where the claim contains the term and the court looks to the specification for a definition of the term, even if that definition is set forth in a preferred embodiment. *Curtiss-Wright Flow Control Corp. v. Velan, Inc.*, 438 F.3d 1374, 1378-80 (Fed. Cir. 2006) (claim limited by the term “adjustable” and specification defined term).

Courts may not redraft claims to make them operable or to sustain their validity. *Chef America, Inc. v. Lamb-Weston, Inc.*, 358 F.3d 1371, 1374 (Fed. Cir. 2004). However, “[w]hen claims are amenable to more than one construction, they should when reasonably possible be interpreted so as to preserve their validity.” *Modine Mfg. Co. v. U.S. Int’l Trade Comm’n*, 75 F.3d 1545, 1557 (Fed. Cir. 1996).

B. Use of Expert Testimony

Expert testimony regarding the construction of claim terms is outside the claims, the specification, and the prosecution history and is, therefore, extrinsic to those vital sources of

information. If the intrinsic information from those sources is unambiguous or sufficient for claims construction, a court should not rely on extrinsic evidence, such as expert testimony, to determine the meaning of the claims. *Boss Control, Inc. v. Bombardier, Inc.*, 410 F.3d 1372, 1377 (Fed. Cir. 2005); *Bell & Howell Doc. Mgmt. v. Altek Sys.*, 132 F.3d 701, 706 (Fed. Cir. 1977). That is, extrinsic evidence may not be “used to vary claim terms from how they are defined, even implicitly, in the specification or file history.” *Vitronics*, 90 F.3d 1584-85. However, extrinsic evidence may be considered for the purpose of:

- (1) providing background on the technology;
- (2) explaining how an invention works;
- (3) ensuring that the court’s understanding of the technical aspects comports with that of a person skilled in the art; and/or
- (4) establishing that a particular term in the patent or prior art has a particular meaning in the relevant field.

Phillips, 415 F.3d at 1318. Whether to admit extrinsic expert testimony lies in a court’s discretion. *Inpro II Licensing, S.A.R.L. v. T-Mobile USA, Inc.*, 450 F.3d 1350, 1357 (Fed. Cir. 2006); *Serio-US Indus., Inc. v. Plastic Recovery Tech. Corp.*, 459 F.3d 1311, 1319 (Fed. Cir. 2006). If admitted, expert testimony must be considered in the context of the patent and the file history. *Phillips*, 415 F.3d at 1319.

In this case, the Court held a tutorial hearing on September 3, 2008, prior to the *Markman* hearing. At the tutorial, the Court heard and admitted evidence from experts falling under the first three categories identified in *Phillips*. Papst also sought to admit expert evidence for the purpose of the claims construction hearing. Papst submitted with its opening brief the declaration of an expert, C. Douglass Locke, Ph.D. See Papst’s *Markman* Br., Ex. C. Because the intrinsic

evidence the claims, the specification, and the prosecution history provide the full record necessary for claims construction, the Court did not admit expert testimony at the *Markman* hearing. To the extent that Papst relies on the Locke Declaration for the definition of the claims in the Patents, see Papst's *Markman* Br. at 21-24, the Court will disregard the Declaration.

III. ANALYSIS

The Camera Manufacturers have asked the Court to construe a series of terms from the Patents. Papst approached the *Markman* briefing with a less specific (and less helpful) analysis that combined terms and concepts directed more to the accused cameras than to the invention itself. The task is made more difficult because the invention was never, as far as the record reveals, actually manufactured or used as contemplated by the inventor. The Court directed argument at the hearing to follow the order of terms identified by the Camera Manufacturers in Exhibit R to their opening *Markman* Brief [Dkt #188] and thereafter to address a few additional terms proposed for construction by Papst (some of the latter are no longer at issue). Thus, the Court construes the following terms from the Patents:

- A. "interface device"
- B. "host device"
- C. "data transmit/receive device"
- D. "for communication between [the host device and the data transmit/receive device]"
- E. "multi-purpose interface"
- F. "interfacing"
- G. "a first connecting device for interfacing the host device with the interface device via the multi-purpose interface of the host device"

- H. “second connecting device for interfacing the interface device with the data transmit/receive device”
- I. “first command interpreter” and “sends a signal regardless of the type of data”
- J. “second command interpreter”
- K. “wherein the interface device is configured by the processor and memory to include a first command interpreter and a second command interpreter”
- L. “inquiry” and “inquiring”
- M. “the driver”
- N. “an input/output [storage] device customary in a host device”
- O. “the driver for the input/output [storage] device customary in a host device”
- P. “the usual driver for the input/output [storage] device”
- Q. “whereupon the host device communicates with the interface device by means of the driver for the input/output [storage] device customary in a host device”
- R. “the digital data”
- S. buffer terms “a buffer to buffer data to be transferred between the data transmit/receive device and the host device” and “a data buffer for permitting independence in terms of time of the data transmit/receive device attachable to the second connecting device from the host device”
- T. “virtual files”
- U. “simulating a virtual file system”
- V. “specific driver for the multi-purpose interface”
- W. “digital signal processor”
- X. “memory”
- Y. “root directory” and “processor”
- Z. Claim Two of the '399 Patent

A. “interface device”

The Camera Manufacturers propose that the term “interface device” be construed to mean “a stand-alone device that a user can readily physically connect to and disconnect from a host device and a data transmit/receive device and that directs communication between these devices when they are connected.” Tr. 1:104 (CMs). They assert that the invented “interface device” is for communicating between a host device and a data transmit/receive device, *i.e.*, the invention is neither the host nor the data transmit/receive device, but rather a separate device that enables communication between the other two. Papst retorts that “interface device” should be construed to mean the structure defined in the body of the Claims and that nothing in the Claims requires the interface device to be separate from the data transmit/receive device.⁵

Claim One of the Patents contains a preamble that limits the Claim. Claim One of the Patents states:

What is claimed is:

1. *An interface device for communication between a host device, which comprises drivers for input/output devices customary in a host device and a multi-purpose interface, and a data transmit/receive device, the data transmit/receive device being arranged for providing analog data, comprising:*

a processor;

a memory;

⁵ Papst recognizes that the data transmit/receive device may be separate from the interface device. It appears to argue, however, that according to the invention the interface device and the data transmit/receive device could be in a single device. *See* Tr. 1:123 (Papst) (“[T]he data transmit/receive device, you know, that’s the part that doesn’t have to be part of the interface device. . . . [T]his claim would be infringed whether or not you include the data transmit/receive device in the final product.”). Papst does not contend that the interface device could be inside the chassis of the host device, the computer.

a first connecting device . . . ; and

a second connecting device

'399 Patent, col. 12:41-53 (emphasis added); '449 Patent, col. 11:45-57(same). The preamble to Claim One is the portion in italics above. Papst asserts that the term "interface device" as set forth in the preamble does not limit the Claim and thus the term should not be construed by the Court. Specifically, Papst contends that the preamble uses the words "[a]n interface device . . . comprising," thereby indicating that the invention is defined in the body of the Claim, *i.e.*, "a processor; a memory; a first connecting device . . . ; and a second connecting device" '399 Patent, col. 12:48-54; '449 Patent, col. 11:51-57. Papst further argues that to construe the term "interface device" in the preamble would be to improperly import limitations from the specification into the Claim. *See Phillips*, 415 F.3d at 1323.⁶

The preamble to Claim One serves as a claim limitation for three reasons. First, "[i]f the claim preamble, when read in the context of the entire claim, recites limitations of the claim, or if the claim preamble is necessary to give life, meaning, and vitality to the claim, then the claim preamble should be construed as if in the balance of the claim." *Pitney Bowes*, 182 F.3d at 1305 (internal quotation omitted). In these Patents, the preamble is limiting because it describes structures that comprise the invention and the relationships among those structures: "An interface device for communication between a host device . . . and a data transmit receive device." *See* '399 Patent, col. 12:42-45; '449 Patent, col. 11:46-49.

Second, where a preamble provides an antecedent basis for terms found in the body

⁶ Despite its position that the term "interface device" should not be construed, Papst concedes that the terms "host device" and "data transmit/receive device" which are also found in the preamble "may benefit from further explanation because some actual claim elements are defined in terms of their relationship to those terms." Papst's *Markman* Br. at 15.

of the claims, it acts as a “necessary component of the claimed invention” and serves as a claim limitation. *Bicon, Inc. v. Straumann Co.*, 441 F.3d 945, 952-53 (Fed. Cir. 2006). Here, the body of the Patents repeatedly refers back to the structures first identified in the preamble by using the word “the” and thus incorporates the terms by reference. *See, e.g.*, ’399 Patent, col. 12:50-52 (“a first connecting device for interfacing the host device with the interface device”); ’449 Patent, col. 11:53-55 (same).

Third, where a preamble is used during prosecution of the patent to distinguish prior art, the preamble may serve as a claim limitation. *In re Cruciferous Sprout Litig.*, 301 F.3d 1343, 1347 (Fed. Cir. 2008). In the prosecution history for the ’399 Patent, Mr. Tasler distinguished prior art (the McNeil patent, U.S. Patent No. 5,499,378) by amending the preamble to state “. . . and a data transmit/receive device, the data transmit/receive device being arranged for providing analog data” CMS’ *Markman Br.*, Ex. C (“ ’399 File History”) at 4-7 (underlined in original to show additional phrase). The preamble, as amended to distinguish prior art, serves as a claim limitation.

In sum, because the preamble describes the structure of the invention and gives meaning to Claim One, it must be interpreted as a claim limitation. Accordingly, the term “interface device” as used in the preamble should be construed.

The body of Claim One of the Patents indicates that the “interface device” is a stand-alone device. The ’399 Patent describes the communication (via the interface device) between a host device and a data transmit/receive device as involving a first command interpreter that, when asked by the computer “as to a type of a device attached to the multi-purpose interface of the host device [computer], sends a signal, regardless of the type of the data transmit/receive device attached to the second connecting device of the interface device . . . that it is an input/output device customary in

a host device.” ’399 Patent, col. 12:66-67 & col. 13:1-5. The ’449 Patent is similar:

the interface device is configured by the processor and the memory in such a way that the interface device, when receiving an inquiry from the host device as to the type of a device attached to the multi-purpose interface of the host device, sends a signal, regardless of the type of the data transmit/receive device attached to the second connecting device of the interface device, to the host device which signals to the host device that it is a storage device customary in a host device

’449 Patent, col. 11:59-67. In both Patents, the language “regardless of the type of the data transmit/receive device attached” strongly indicates that various kinds of data transmit/receive devices could be attached and that, therefore, the interface device was neither a permanent part of the data transmit/receive device nor of the host device/computer.

Similar language is repeated throughout both Patents. *See, e.g.*, ’399 Patent, Title, Abstract & col. 3:43-44 (“regardless” language); ’449 Patent, Title, Abstract & col. 4:6-7 (same); *see also* ’399 Patent, col. 3:24-27 (“It is an object of the present invention to provide an interface device for communication between a host device and a data transmit/receive device whose use is host device-independent”); ’449 Patent, col. 3:20-23 (“It is *the* object of the present invention to provide an interface device for communication between a host device and a data transmit/receive device whose use is host device-independent”) (emphasis added).

That the data transmit/receive device must be a separate device from the invention is not mere happenstance but an integral aspect of what was invented. Whatever uncertainty on this point may exist after studying the Claims is eliminated upon a review of the specification. The specification always describes three separate devices: the computer, the data transmit/receive device (an I/O device), and the interface device. *See, e.g.*, ’399 Patent, Title, Abstract, col. 1:1-14, col. 3:25-28, col. 5:30-32, col. 5:47-63, Figs. 1-2 and accompanying text; ’449 Patent, Title, Abstract,

col. 1:1-17, col. 3:21-23, col. 4:35-36, col. 4:40-63, Figs. 1-2 and accompanying text; *see also* '399 Patent, col. 5:56-60 (describing Figure 1 as showing that the "second connecting device can be attached by means of an output line 16 to a data transmit/receive device which is to receive data from the host device or from which data is to be read, *i.e.* acquired, and transferred to the host device."); '449 Patent, col. 4:55-59 (same).

As explicitly explained in the specification, one of the problems with prior art, when attached "to a device whose data is to be acquired," was that "it is often very difficult to implement such interfaces for *portable* systems and they offer few possibilities for adaptation with the result that such systems offer *little flexibility*." '399 Patent, col. 1:21-22 & 31-34 (emphases added); '449 Patent, col. 1:22-23 & 32-35 (same). And yet portability and flexibility were critical because "[t]he devices from which data is to be acquired cover the entire electrical engineering spectrum." '399 Patent, col. 1:34-35; '449 Patent, col. 1:35-36. "[A]n interface may be put to totally different uses. It is therefore desirable that an interface be sufficiently *flexible* to permit attachment of very different electrical or electronic systems to a host device by means of the interface." '399 Patent, col. 1:56-59 (emphasis added); '449 Patent, col. 1:57-60 (same).

The invention was designed to answer these shortcomings of prior art and to provide a "flexible interface" that would allow communication between a computer and "an analog I/O device . . . regardless of the type of the I/O device." '399 Patent, Title; '449 Patent, Title. The specification touts the "enormous" benefit of allowing communication between a computer and many different types of data transmit/receive devices:

In the interface device *according to the present invention an enormous advantage is to be gained*, as apparent in the embodiment described in the following, in separating the actual hardware required

to attach the interface device 10⁷ to the data transmit/receive device from the communication unit . . . as *this allows a plurality of dissimilar device types* to be operated in parallel in identical manner.

'399 Patent, col. 8:23-31 (emphases added); '449 Patent, col. 7:23-31 (same). It is well-settled that “[w]hen a patent thus describes the features of the ‘present invention’ as a whole, this description limits the scope of the invention.” *Verizon Servs. Corp. v. Vonage Holdings Corp.*, 503 F.3d 1295, 1308 (Fed. Cir. 2007). The description in the specification, therefore, necessarily limits the scope of the '399 and '449 Patents when it refers to the enormous advantage of “*the present invention,*” to allow a plurality of dissimilar input/output devices to be accessed.

The specification also explains that the interface device provides a “universal solution” without regard to the types of data transmit/receive devices from which data may be acquired. '399 Patent, col. 12:37-40 (“The interface device 10 thus provides a universal solution which can cover the entire spectrum of possible data transmit/receive devices.”); '449 Patent, col. 11:41-44 (same). Examples of transmit/receive devices that can be connected to a computer via the interface device include a “diagnostic radiology system in a medical engineering environment” and a “multimeter.” '399 Patent, col. 1:34-54; '449 Patent, col. 1:35-55. The specification also notes the advantage to users of the interface device that they can obtain data from almost any data transmit/receive device with little prior knowledge:

By creating and editing a configuration file, normally a text file which is simple to understand with little prior knowledge, users of the interface device 10 are able to perform essentially identical operator actions for almost any data transmit/receive devices which can be

⁷ At times, the specification refers to the invention, its various components, and the devices to which it connects by numbers shown in Figure One as follows: interface device 10; host device 11; first connecting device 12; digital signal processor 13; memory 14; second connecting device 15; and data transmit/receive device 16. *See* '399 Patent, Sheet One; '449 Patent, Sheet One.

attached to the second connecting device via the line 16, thus eliminating a source of error arising from users having to know many different command codes for different applications.

'399 Patent, col. 7:37-45; '449 Patent, col. 6:37-45; *see also* '399 Patent, col. 1:34-46 (explaining that the interface device could be used to simplify the data read/acquisition work of field technicians); '449 Patent, col. 1:35-47 (same).

As one learns from studying the Patents, the purpose of the invention was to allow fast communication between dissimilar data transmit/receive devices and computers, without the need for special software drivers. Thus, the invention cannot properly be limited to an interface device that is incapable of allowing a plurality of dissimilar transmit/receive devices to be connected or that cannot be flexible and portable to allow a plurality of dissimilar transmit/receive devices to be attached.

This conclusion is further buttressed by the identical Figures that accompany each Patent. Figure 1 of each Patent "shows a general block diagram of the interface device according to the present invention," *see* '399 Patent, col. 5:38-39; '449 Patent, col. 4:41-42, and the Figure indicates that the data transmit/receive device is off the sheet, out of sight, not part of the Figure, and not part of the invention. '399 Patent, Sheet 1 ("to data transmit/receive device"; lower case substituted); '449 Patent, Sheet 1 (same). Figure 2 of each Patent, which depicts a preferred embodiment of the invention, also indicates that the data transmit/receive device and the host device/computer are separate and apart from the invention. '399 Patent, Sheet 2; '449 Patent, Sheet 2. The specification and Figures further indicate that the interface device is separate from the host computer and the transmit/receive device because it is designed to plug into an electrical outlet. *See* '399 Patent col. 9:65-66 ("The complete interface device 10 is supplied with power by an external AC/DC

converter 1800”); ’449 Patent, col. 8:65-66 (same); *see also* ’399 Patent, Sheet 2; ’449 Patent, Sheet 2.

The prosecution history of the ’399 Patent also supports the conclusion that the interface device is a stand-alone device. Mr. Tasler amended Claim One to add the phrase, “wherein the first command interpreter is configured in such a way that the command interpreter, when receiving an inquiry from the host device as to [the] a type of a device attached to the multi-purpose interface of the host device.” ’399 File History at 7 (underlined in original to show additional phrase; brackets in original to show deleted word).⁸ The change from “the device” to “a device” is a change to more general language, indicating that the interface device was intended to be attached to, and detached from, various types of input/output devices. Mr. Tasler also explained to the PTO that “it is clear that the data transmit/receive device *to be connected* to the second connecting device of the subject interface provides analog data.” *Id.* at 5 (emphasis added). The statement that the data transmit/receive device is “to be connected” similarly indicates that the inventor did not intend the interface device to be permanently affixed to a single data transmit/receive device, as it is “to be connected” to various data transmit/receive devices.

Papst argues that interpreting “interface device” to mean a stand-alone device would “improperly import[] the limitations from the spec[ification] to the claims. The claims don’t say stand alone, they don’t say physically connect, or readily connect or disconnect” Tr. 1:84 (Papst). The Court disagrees. The interface device, as discussed further below, “sends a signal, regardless of the type of the data transmit/receive device attached to the second connecting device

⁸ Interestingly, Mr. Tasler reverted to the language “the device” in the ’449 Patent. ’449 Patent, col. 11:62.

of the interface device.” ’399 Patent, col. 13:1-5; ’449 Patent, col. 11:63-65. Claim One contemplates and intends that a variety of transmit/receive devices may be connected to the interface device, which is also connected to the computer. To fulfill claim One, the “interface device” must, therefore, be a “stand-alone device.”

B. “host device”

Claim One of both Patents claims “[a]n interface device for communication between a *host device*, which comprises drivers for input/output devices customary in a *host device* and a multi-purpose interface, and a data transmit/receive device” ’399 Patent, col. 12:42-45 (emphasis added); ’449 Patent, col. 11:46-49 (same). The Camera Manufacturers propose that “host device” be construed to mean “a general purpose computer that connects to and controls the operation of peripherals,” CMs’ *Markman* Br. at 9, while Papst proposes “a general purpose computer to which hardware devices may be attached, such as Personal Computers (“PCs”) and other host computer systems as described in the patent written description, including drivers for input/output devices customary in a host device and a multi-purpose interface.” Papst’s Revised Appendix of Claim Constructions [Dkt. # 244, Ex. C] (“Papst’s App.”) at 2. Papst also objects to the phrase “controls the operation of peripherals” in the Camera Manufacturers’ proposed definition. Neither Figure One nor Figure Two of the Patents shows a “host device;” the Figures only indicate where one would be connected to the invention.

The Patent Claims refer solely to a “host device,” but the specification clarifies the nature of the intended host device. *See* ’399 Patent, col. 1:9-11 (“The present invention relates to the transfer of data and in particular to interface devices for communication between a *computer or host device* and a data transmit/receive device”) (emphasis added); ’449 Patent, col. 1:13-15

The Court construes “host device” in the Claims of the Patents to mean “a general purpose computer that connects to and directs the operation of peripherals, including drivers for input/output devices customary in a host device and a multi-purpose interface.”

C. “data transmit/receive device” and “the data transmit/receive device being arranged for providing analog data”¹⁰

Mr. Tasler did not invent a data transmit/receive device, and Papst objects to any construction of the term. Tr. 1:136 (Papst) (“So our first position, of course, is that we shouldn’t be defining this as part of the claimed invention.”). While Papst asserts that the term “data transmit/receive device” is not a claim limitation, Papst concedes that the term may be construed “for context” as “a device that receives input and provides data to the interface device.” Papst’s App. at 2. The Court agrees that it should not define the nature of a data transmit/receive device. What is at issue, however, is the communication capability between the invented interface device and a data transmit/receive device, which is very much part of construing the Claims, and the Court construes “data transmit/receive device” in this context.

The parties disagree as to whether the “data transmit/receive device” mentioned in the Patents must be capable of performing two-way communication. Papst cites to the specification, to wit, “The present invention relates to the transfer of data and in particular to interfaces for communication between a computer or host device and a data transmit/receive device from which data is to be acquired *or* with which two-way communication is to take place.” ’399 Patent, col. 1:9-13 (emphasis added); ’449 Patent, col. 1:13-17 (same). The Camera Manufacturers propose to

¹⁰ “In the 399 Patent the claims do require that the . . . interface device be able to receive analog data. In the 449 Patent the claims do not recite that the interface device has to receive analog data.” Tr. 1:21 (Papst).

construe the term as “a device that *transmits data to and receives data from* the host device when connected to the host device by the interface device.” CMs’ *Markman* Br. at 10 (emphasis added). These positions are again hotly contested on reconsideration.

The Court turns to the claim language in the first instance and then to the specification for elucidation. *Phillips*, 415 F.3d at 1315 (the specification is the “single best guide to the meaning of a disputed term” and “[u]sually it is dispositive”). The preamble to Claim One of the Patents states, “[a]n interface device for *communication between* a host device . . . and a data transmit/receive device” ’399 Patent, col. 12:42-45 (emphasis added); ’449 Patent, col. 11:47-49 (same). “Communication between” suggests bi-lateral interchanges.¹¹

Figures 1 and 2 that accompany both Patents show bidirectional arrows connecting the invention to the data transmit/receive device. Figure 1 “shows a general block diagram of *the* interface device *according to the present invention*” and Figure 2 shows a “detailed block diagram of *an* interface device *according to a preferred embodiment* of the present invention.” ’399 Patent, col. 5:38-42; ’449 Patent, col. 4:41-44 (emphases added); *see* ’399 col. 9:29-30 (“In the preferred embodiment of the interface device 10 shown in FIG. 2”); ’449, col. 8:29-30 (same); *but see* ’399 col. 9:15-16 (“Figure 2 shows a detailed block diagram of an interface device, according to *the* present invention”) (emphasis added); ’449, col. 8:15-16 (same). Again, the description of features of “the present invention” limits the scope of the invention. *Verizon*, 503 F.3d at 1308. In explaining the invention, Mr. Tasler specified that his Figures contained “bidirectional

¹¹ Claim One of the ’399 Patent uses the words “to” or “from” when discussing one-way communication. *See, e.g.*, ’399 Patent, col. 13:8-13 (“wherein the second command interpreter is configured to interpret a data request command *from* the host device *to* the type of input/output device signaled by the first command interpreter as a data transfer command for initiating a transfer of the digital data *to* the host device.”) (emphases added).

communication lines (shown for all lines by means of two directional arrows).” ’399 Patent, col. 5:49-56; ’449 Patent, col. 4:51-55 (same except “bidirectional” is spelled “bi-directional”). In other words, he describes an invention in which communication appears to go in both directions.

Additionally, in providing background to the invention, the specification states that “[t]he devices from which data is to be acquired cover the entire electrical engineering spectrum” and constitute “very different electrical or electronic systems.” ’399 Patent, col. 1:34-35, 56-59; ’449 Patent, col. 1:36-37, 57-60; *see also* ’399 Patent, col. 12:37-40 (the specification concludes, “[t]he interface device thus provides a universal solution which can cover the entire spectrum of possible data transmit/receive devices.”); ’449 Patent, col. 11:41-44 (same).

Even more pointed language in the specification describes Figure 1 as showing:

The second connecting device can be attached by means of an output line 16 to a data transmit/receive device which is to receive data from the host device or from which data is to be read, i.e. acquired, and transferred to the host device. The data transmit/receive device itself can also communicate actively with the host device via the first and second connecting device

’399 Patent, col. 5:56-62; ’449 Patent, col. 4:55-61. This language supports the conclusion that, as its name implies, the data transmit/receive device is to “receive data from the host device,” or it is the site “from which data is to be read” and it “can also communicate actively with the host device.” *Id.* The specification also notes an “important advantage of the interface device of the present invention” is the “extremely high data transfer rates by using, *for data interchange*, the host device-own [sic] BIOS routines.” ’399 Patent, col. 8:43-46; ’449 Patent, col. 7:43-47 (emphasis added).

In every instance, the Claims, Figures, and specification refer to data transmit/receive devices and not to “data transmit devices” or “data transmit or receive devices.” In fact, the name

of the interface device itself emphasizes that both data transfer and receipt are important attributes of the data transfer/receive device: the invention is a “flexible interface for communication between a host and an analog I/O device,” *i.e.*, the data transmit/receive device is an input and output device. ’399 Patent, Title; ’449 Patent, Title.

From this analysis, the Court initially concluded, “While the data transmit/receive device does not engage in two-way communication at all times, the Claims and specification require it to have the capability of two-way communication.” Mem. Op. [Dkt. # 312] at 29. On reconsideration, the Court finds that it erred, despite the language of the specification on which it relied.

In both Figures 1 and 2, the line identified as 16 has two-way arrows, which the inventor informs us means “bidirectional communication lines (shown for all lines by means of two directional arrows).” ’399 Patent, col. 5:55-56; ’449 Patent, col. 4:54-55 (same except “bidirectional” is spelled “bi-directional”). However, while Figure 2 shows bidirectional arrows between the interface device and the transmit/receive device, the internal structure of the interface device in Figure 2 reveals unidirectional interaction, with Bayonet Neill-Conselman (BNC) connectors that can only receive data and single direction arrows flowing from the sample and hold circuit (which receives its data from the transmit/receive device) toward the other components of the interface device, including the analog to digital converter and the data signal processor. *See* ’399 Patent, Sheet 2; ’449 Patent, Sheet 2. There is no circuitry revealed in Figure 2 which would transfer data *from* the interface device *to* the transmit/receive device even though the specification describes it as having “bidirectional communication lines.”

This point is argued strenuously by the parties in their briefs on reconsideration.¹² Papst has the better side of the argument. “[I]t is unlikely that an inventor would define the invention in a way that excluded the preferred embodiment.” *Hoechst Celanese Corp. v. BP Chemicals, Ltd.*, 78 F.3d 1575, 1581 (Fed. Cir. 1996). Figure 2, the preferred embodiment, shows a device that can acquire data from the data transmit/receive device but cannot send data back to the data transmit/receive device via line 16. With this understanding, the first sentence of the specification referring to “a data transmit/receive device from which data is to be acquired *or* with which two-way communication is to take place”¹³ takes on new meaning.

The Court thus construes the term “data transmit/receive device” to mean “a device that is capable of either (a) transmitting data to or (b) transmitting data to and receiving data from the host device when connected to the host device by the interface device.”

D. “for communication between [the host device and the data transmit/receive device]”

Papst proposes that “for communication between” the computer and the data transmit/receive device should be construed to include one-way or two-way communication, or both. Papst’s App. at 2; *see also* Papst’s Mot. for Reconsideration [Dkt. # 321] at 7. The Camera Manufacturers propose that the phrase “for communication between” means “for transmitting of information bidirectionally and actively between the two devices.” CMs’ PowerPoint Slides [Dkt. # 267] (“CMs’ Slides”) at 55.

¹² It was the Court’s neutral expert, Dr. Ronald Williams, who noted the anomaly between the language of the specification and the bidirectionality of the line at 16 compared to the BNC receptors in Figure 2, which are incapable of sending data to the data transmit/receive device. *See* Mem. Op. [Dkt. # 312] at 28 n.12.

¹³ *See* ’399 Patent at 1:12-14; ’449 Patent col. 1:15-17.

mean “a communication interface designed for use with multiple devices having different functions from each other.” CMs’ Slides at 62. Papst proposes that it means “a computer interface which supports more than one type of device.” Papst’s App. at 2. Papst conceded at the *Markman* hearing that the definition proposed by the Camera Manufacturers is satisfactory, as long as it provides that multiple devices are connected one at a time. Tr. 1:156-57 (Papst) (“COURT: Your problem is temporal, not otherwise. You don’t have any problem with multiple devices having different functions from each other as long as they’re plugged in one at a time? PAST: Right, Your Honor.”). The Patents do not answer this point,¹⁴ and the Court declines to add an unspoken limitation. With the parties’ essential agreement, the Court thus construes “multi-purpose interface” to mean “a communication interface designed for use with multiple devices that can have different functions from each other.”

F. “interfacing”

The Patents state, “a first connecting device for *interfacing* the host device with the interface device via the multi-purpose interface of the host device; and a second connecting device for *interfacing* the interface device with the data transmit/receive device” ’399 Patent, col. 12:51-55; ’449 Patent, col. 11:54-58. Papst suggests that “interfacing” refers to “establishing communication with the computer,” *i.e.*, electronic data communication and not physical connection. Papst’s App. at 3; *see also* Tr. 1:158-59 (Papst). The Camera Manufacturers insist that “interfacing” means “physically connecting.” CMs’ Slides at 69.

¹⁴ *See* ’399 Patent, col. 4:48 (ambiguously stating, “[c]ommunication between the host device and the devices attached to the multi-purpose interface then essentially takes place by means of the specific driver software for the multi-purpose interface” without indicating whether such devices are connected to the multi-purpose interface one at a time).

Papst proposes the better construction. “Interfacing” means establishing communication or enabling communication between two devices. Figure 2, the preferred embodiment of the invention, shows a 10MB/s SCSI interface chip. *See* ’399 Patent, Sheet 2; ’449 Patent, Sheet 2. The chip does the work of interfacing with the host computer, while the 50-pin connector to which it is attached does the job of connecting.¹⁵

The Camera Manufacturers object to Papst’s proposed construction by pointing out that “interfacing” is what the first and second connecting devices do, while communicating is what the command interpreters do. The Court does not disagree. But the Court does not interpret “interfacing” as communicating. “Interfacing” means making communication possible. “[I]nterfacing isn’t really about the physical connections, it’s about establishing the communication and in getting information across the boundary.” Tr. 1:166 (Papst). Interfacing “is getting the right electrical signals in the right order with the right voltages with the right timing.” Tr. 2:13 (Papst). Accordingly, the Court construes “interfacing” as used in the Patent Claims as meaning “establishing communication with.”

G. “a first connecting device for interfacing the host device with the interface device via the multi-purpose interface of the host device”

The parties part ways dramatically on the construction of the term “the first connecting device” in the phrase “a first connecting device for interfacing the host device with the interface device via the multi-purpose interface of the host device.” *See* ’399 Patent, col. 12:51-53; ’449 Patent, col. 11:53-55. The Camera Manufacturers propose that the “first connecting device” is “a physical plug or socket for permitting a user to readily attach and detach the interface device

¹⁵ *See* discussion of the term “connecting device” below.

with the host device.” CMs’ Slides at 77. Papst does not construe the term “connecting device” as an object, but jumps instead to the interfacing function of the first connecting device and proposes that the first connecting device be construed to mean “the circuit device used to *couple* the interface device to the multi-purpose interface of a computer.” Papst’s App. at 3 (emphasis added). Papst asserts that “the first connecting device needs to be interpreted along with the entire paragraph . . . and it’s the connecting device for interfacing with the multi-purpose interface.” Tr. 2:12 (Papst). Papst then goes on to describe its interpretation of “interfacing:”

[Interfacing] means adhering to the protocols for the electrical signals and the formatting of the data as it goes out [and] when it’s being transmitted from one device to another. And that’s how you achieve interfacing in the context of this claim.

. . .

So while the software is generating the information that gets sent, the connecting device is what actually, . . . that’s where the information gets turned into a signal and in the case of a SCSI [small computer system interface] interface gets put on a wire [T]hat’s what is meant by interfacing and this is getting the right electrical signals in the right order with the right voltages with the right timing.

Id. at 12-13 (Papst).

The Claims, Figure 2, and the specification do not support Papst’s definition as it would apply to “first connecting device.” The Claims explain that the first connecting device is used “for interfacing,” for establishing communication as defined above. That function does not describe the physical nature of the first connecting device itself. Taken into a different context, Papst’s proposed construction would confuse a wall socket that accepts the plug from a lamp with the function that, once a plug is entered into a wall socket, the wall socket allows alternating current to reach the lamp and light its bulb. Despite this function, no one could confuse the wall socket itself

with the current that flows after a plug is inserted.

The specification illustrates the physical nature of the first connecting device. The specification describes the first connecting device as containing various devices which require a physical, wired connection:

In the preferred embodiment of the interface device 10 shown in FIG. 2, the first connecting device 12 of FIG. 1 contains the following components: an SCSI interface 1220 and a 50-pin SCSI connector 1240 for attachment to an SCSI interface present on most host devices or laptops. The SCSI (small computer system interface) 1220 translates the data received via the SCSI connector 1240 into data understood by the DSP 1300, as known by those skilled in the art. Further, the first connecting device 12 comprises an EPP (enhanced parallel port) with a data transfer rate of approx. 1 MBps which delivers a more moderate data transfer rate of 1 MBps by comparison to the data transfer rate of 10 MBps of the SCSI interface. The EPP 1260 is connected to a 25-pin D-shell connector 1280 to permit attachment to a printer interface of a host device for example. Optionally, the first connecting device 12 also comprises a 25-pin connector 1282 which permits the attachment of 8 digital outputs and 8 digital inputs 1284 at the host device.

'399 Patent, col. 9:29-47; '449 Patent, col. 8:30-48. Figure 2 shows a "25-pin connector," a "25-pin D-shell connector," and a "50-pin SCSI connector" for connecting a cable between the interface device and the host device/computer. See '399 Patent, Sheet 2; '449 Patent, Sheet 2; see also Tr. 1:164-65 (Papst) (the SCSI device shown in Figure 2 would require a wired connection).

Further, the specification refers to "attachment" of various types of transmit/receive devices, via the interface device, to a host computer. See '399 Patent, col. 1:56-59 ("It is therefore desirable that an interface be sufficiently flexible to permit *attachment* of very different electrical or electronic systems to a host device by means of the interface.") (emphasis added); '449 Patent, col. 1:57-60 (same). And, the specification refers to a "line" connecting the host computer and the interface device: "whereby the [second command interpreter] begins to transfer data from the data

transmit/receive device via the second connecting device *and via the line 11 to the host device.*” ’399 Patent, col. 6:53-67 (emphasis added). The terms “attachment” and “line” connote a physical connection.

The “first connecting device” is, therefore, a socket with a varying physical arrangement of pins (connectors) that allows different cables whatever cable would allow connection to the relevant host device/computer to be plugged into the interface device. The socket’s pin arrangement could change as the nature of cables changed. The applicable cables that were known to those trained in the art as of 1998, when Mr. Tasler applied for the ’399 Patent, were exhibited to the Court during the tutorial and were physical objects that required physical pin receptors to connect to a device.¹⁶

A socket is the opposite of a plug; that is, a socket is the “female” end of a connection and a plug is the “male” end. While Figure 2 illustrates sockets with pins that allow cables to connect the host device/computer with the invented interface device, such an arrangement is only a preferred embodiment and its opposite might also be anticipated to comply fully with the invention. Thus, a first connecting device may be either a physical socket or a plug. *See, e.g.,* CMS’ *Markman* Br., Ex. D, Am. Heritage Dictionary of Computer and Internet Words 59 (2001) (connector defined as “A coupler used to join two cables or to plug a cable into a port or interface.”); *id.*, Ex. E, Am. Heritage Dictionary of Computer Words 54 (1995) (same).¹⁷

¹⁶ A similar assortment of connectors, although considerably smaller, can be seen on the back and sides of today’s laptop computers.

¹⁷ Dictionaries may be consulted at any time to better understand the technology involved in the case. *Vitronics*, 90 F.3d at 1584 n.6. Courts may look to dictionary definitions when construing claim terms, “so long as the dictionary definition does not contradict any definition found in or ascertained by a reading of the patent documents.” *Id.*; *see Phillips*, 415 F.3d at 1321 (cautioning

Papst contends that a first connecting device does not need to be a physical plug or socket because the patented device could use a wireless multi-purpose interface. Tr. 1:159-61 (Papst). Papst confuses “interfacing” and “connecting device.” The former concerns “the protocols for the electrical signals and the formatting of the data,” Tr. 2:12 (Papst), while the latter is a physical device in these Patents. Accordingly, the Court construes “first connecting device” to mean “a physical socket or plug for permitting a user to attach and detach the interface device to and from a host device/computer.”

H. “second connecting device for interfacing the interface device with the data transmit/receive device”

The parties construe the “second connecting device” in ways that mirror their proposed constructions of the “first connecting device.” The Camera Manufacturers propose a “physical plug or socket for permitting a user to readily attach and detach the interface device with a plurality of dissimilar data transmit/receive devices.” CMs’ Slides at 87. Papst distinguishes between the ’399 and ’449 Patents in its definition: Papst would define the “second connecting device” in the ’449 Patent as “the circuit device used to couple the data transmit/receive device to the interface device.” It would construe the same language in the ’399 Patent as the structure recited in the Claim, that is, “a sampling circuit for sampling the analog data provided by the data transmit/receive device and an analog-to-digital converter for converting data sampled by the sampling circuit into digital data.” Papst App. 3 & 9-10; *see* ’399 Patent, col. 12:55-60. Papst contends that the second connecting device in the ’399 Patent is a device for sampling and

that “too often [courts] have condoned the adoption of a dictionary definition entirely divorced from the context of the written description” of the patent.).

converting analog to digital, not a connector.

The second connecting device has multiple purposes: 1) it allows line 16 to be physically attached to the interface device and thus, it is a physical connector, as is the first connecting device. In the preferred embodiment shown in Figure 2, it includes, internal to the interface device, BNC [Bayonet Neill-Conselman] receptors and a sample and hold circuit.

The prosecution history is helpful. As initially presented to the PTO, Claim One of the '399 Patent referred to a second connecting device for interfacing. Tr. 1:185 (CMs). To avoid prior art, Mr. Tasler later amended his patent by inserting the language specifying that the second connecting device included a sampling circuit and an analog to digital converter. '399 File History at 7 (version with markings to show changes). This history indicates that the processing capabilities of the second connecting device, although present and critical in the interface device, do not detract from its fundamental status as a physical connector.

The "second connecting device" itself is a plug or socket that accepts the "output line" 16 and allows the connection to be made between the invented interface device and the data transmit/receive device. The specification states that the second connecting device "can be *attached* by means of an *output line* 16 to a data transmit/receive device which is to receive data from the host device or from which data is to be read, i.e. acquired, and transferred to the host device." '399 Patent, col. 5:56-60 (emphases added); '449 Patent, col. 4:55-59 (same). The specification again refers to physical "attachment" via a "line" when it describes the flexibility of the interface device: "[U]sers of the interface device 10 are able to perform essentially identical operator actions for almost any data transmit/receive devices which can be *attached* to the second connecting device via the *line* 16, thus eliminating a source of error arising from users having to know many different

command codes for different applications.” ’399 Patent, col. 7:39-43 (emphasis added); ’449 Patent, col. 6:39-42 (same). The preferred embodiment of the second connecting device is a BNC input. *See* ’399 Patent, col. 9:49-53 (“Preferably, the second connecting device comprises 8 BNC inputs”); ’449 Patent, col. 8:49-53 (same). The specification underscores the physical nature of the second connecting device by referring to the “actual hardware required to attach the interface device 10 to the data transmit/receive device,” ’399 Patent, col. 8:26-27; ’449 Patent, col. 7:26-27, and the “specific hardware symbolized by the second connecting device.” ’399 Patent, col. 8:34; ’449 Patent, col. 7:34.

The Court construes the “second connecting device” in the ’399 Patent to mean “a physical plug or socket for permitting a user readily to attach and detach the interface device with a plurality of dissimilar data transmit/receive devices, including a sampling circuit for sampling the analog data provided by the data transmit/receive device and an analog-to-digital converter for converting data sampled by the sampling circuit into digital data.” In the ’449 Patent, the “second connecting device” means “a physical plug or socket for permitting a user readily to attach and detach the interface device with a plurality of dissimilar data transmit/receive devices.”

I. “first command interpreter” and “sends a signal regardless of the type of data transmit/receive device”

These terms are used in the context of the ’399 Patent as follows: “the *first command interpreter* . . . , when receiving an inquiry from the host device as to a type of a device attached to the multi-purpose interface of the host device, *sends a signal, regardless of the type of the data transmit/receive device attached* to the second connecting device of the interface device, to the host device which signals to the host device that *it* is an input/output device customary in a host device, whereupon the host device communicates with the interface device by means of the driver for the

interface which comprises the BIOS routines customary in host device”); ’449 Patent, col. 11:16-18 (same); *see also* ’399 Patent, col. 11:32-42 (the hardware-oriented side of the “ASPI manager” is matched to an interface and the other side is the user software side); ’449 Patent, col. 10:32-42 (same). Accordingly, the Court construes “driver” to mean “the set of software routines used to direct a device, for example, an input/output device or a multi-purpose interface.”

**N. “an input/output [storage] device customary in a host device” and
O. “the driver for the input/output [storage] device customary in a host device”**

Claim One of the ’399 Patent recites:

wherein the first command interpreter is configured in such a way that the command interpreter, when receiving an inquiry from the host device as to a type of a device attached to the multi-purpose interface of the host device, sends a signal, regardless of the type of the data transmit/receive device attached to the second connecting device of the interface device, to the host device which signals to the host device that it is *an input/output device customary in a host device*, whereupon the host device communicates with the interface device by means of *the driver for the input/output device customary in a host device*

’399 Patent, col. 12:64-67 & col. 13:1-8 (emphases added).¹⁸

¹⁸ For purposes of construing the contested meaning here, the differences between the ’399 Patent and the ’449 Patent are not relevant. The ’449 Patent states:

wherein the interface device is configured by the processor and the memory in such a way that the interface device, when receiving an inquiry from the host device as to the type of a device attached to the multi-purpose interface of the host device, sends a signal, regardless of the type of the data transmit/receive device attached to the second connecting device of the interface device, to the host device which signals to the host device that it is a storage device customary in a host device, whereupon the host device communicates with the interface device by means of the driver for the storage device customary in a host device

’449 Patent, col. 11:59-67 & col. 12:1-3 (emphases added to identify words not present in the ’399 Patent). For clarity, the Court omits reference to the “storage device” in the ’449 Patent in the

Claim One first states that the interface device sends a signal to the computer that it is “an input/output device customary in a host device” and then that the computer communicates by means of the “driver for the input/output device customary in a host device.” *Id.* The parties agree that the “input/output device” must be “customary in a host device.” But they disagree about what “customary in a host device” means and about whether the adjectival phrase “customary in a host device” modifies “driver.” The Camera Manufacturers contend that the phrase modifies both “an input/output device customary in a host device” means a “data input/output [] that was normally present within the chassis of most commercially available computers at the time of the invention,” Tr. 2:85 (CMs), and “the driver for the input/output device customary in a host device” means “the driver normally present in most commercially available computers at the time of the invention.” CMs’ *Markman* Br. at 26.

According to Papst, the phrase “customary in a host device” modifies “input/output device” and not “driver.” Papst’s Reply at 24-25; Papst’s Slides at 105. Papst asserts that the phrase “an input/output device customary in a host device” means “a hardware device that inputs or outputs data with respect to a host computer, and is a device that is sufficiently common such that software drivers for communicating with the input/output device are typically provided with the host computer as it is purchased. Input/output devices customary in a host device include, for example, hard disk drives, floppy disk drives, CD-ROM drives, tape drives or printers.” Papst’s App. at 4. Papst proposes that “the driver for the input/output device customary in a host device” should be construed in context to mean “upon receiving the ‘signal,’ the host device automatically uses one or more software driver for use with the customary input/output devices to communicate with the

remainder of this discussion.

interface device.” *Id.*

The phrase “customary in a host device” raises three questions: (1) what does “customary” mean?; (2) “customary” as of when?; and (3) what does “in” a host device mean? Tr. 2:85 (CMs). First, the specification expressly defines “customary” as “normally present in most commercially available host devices” as follows:

The present invention is based on the finding that both a high data transfer rate and host device-independent use can be achieved if a driver for an input/output device customary in a host device, normally present in most commercially available host devices, is utilized. Drivers for input/output devices customary in a host device which are found in practically all host devices are, for example, drivers for hard disks, for graphics devices or for printer devices.

’399 Patent, col. 4:23-27; ’449 Patent, col. 3:27-31. When a specification expressly defines a term, as it does here, it acts as a dictionary. *See Vitronics*, 90 F.3d at 1582. Accordingly, “customary” means “normally present in most commercially available host devices.”

The next question—customary as of when?—must be answered: as of 1998 when Mr. Tasler applied for the ’399 Patent. A court must interpret the words of a contested claim from the perspective of one skilled in the art at the time of invention. *See Phillips*, 415 F.3d at 1313. The word “customary” is time-dependent, like the word “conventional” construed by the court in *Muniauction, Inc. v. Thomson Corp.*, 532 F.3d 1318, 1326 (Fed. Cir. 2008). There, the court determined that “conventional” when modifying the term “internet browser” meant web browsers in existence at the time of the invention. *See id.*; accord *PC Connector Solutions LLC v. SmartDisk Corp.*, 406 F.3d 1359, 1363-64 (Fed. Cir. 2005) (input/output port “normally” connectible to a computer port meant technology existing at the time of the invention). A claim cannot be interpreted to have different meanings at different times. *See PC Connector*, 406 F.3d at 1363. The word

“customary” means customary in a host computer at the time of the invention.¹⁹

With regard to the third question what does “in” a host device mean? the answer is straightforward in the context of the phrase “the driver for the input/output device customary in a host device.” The Camera Manufacturers assert that “in” means “in,” that is, within the chassis of the host computer. Tr. 2:86 (CMs). The specification makes it clear that certain “drivers” are “normally present in most commercially available host devices,” *i.e.*, are normally *inside* most computers:

The present invention is based on the finding that both a high data transfer rate and host device-independent use can be achieved if *a driver for an input/output device customary in a host device, normally present in most commercially available host devices*, is utilized. *Drivers for input/output devices customary in a host device which are found in practically all host devices are, for example, drivers for hard disks, for graphics devices or for printer devices.* . . . [T]he hard disk driver is utilized in the preferred embodiment of the interface device of the present invention. Drivers for other storage devices such as floppy disk drives, CD-ROM drives or tape drives could also be utilized in order to implement the interface device according to the present invention.

'399 Patent, col. 4:23-39 (emphases added); '449 Patent, col. 3:26-43 (same). As the specification further explains, the interface device sends a signal to the computer that the computer is communicating with an input/output device, and the interface device then communicates with the computer using either a driver present in the computer's BIOS system or a specific driver for the multi-purpose interface. *See* '399 Patent, col. 5:5-20; '449 Patent, col. 4:9-24.

¹⁹ The Camera Manufacturers argue that Papst conceded that customary is a time-dependent term. Tr. 2:86 (CMs) (“Mr. Kuwala said this very morning that customary is a time dependent term and therefore, it has to be customary at the time of the invention.”). Papst did not concede this issue, however. It merely noted that you “might argue” that the word “customary” imposes a time limitation. Tr. 2:41 (Papst).

The interface device according to the present invention therefore simulates, both in terms of hardware and software, the way in which a conventional input/output device functions, preferably that of a hard disk drive. As support for hard disks is implemented as standard in all commercially available host systems, the simulation of a hard disk, for example, can provide host device-independent use. The interface device according to the present invention therefore no longer communicates with the host device or computer by means of a specially designed driver but by means of a program which is present in the BIOS system (Basic Input/Output System) and is normally precisely matched to the specific computer system on which it is installed, or by means of a specific program for the multi-purpose interface.

'399 Patent, col. 5:5-20; '449 Patent, col. 4:9-24 (same). Thus, what is "in" the computer are the drivers for internal computer components (such as the multi-purpose interface or an internal hard disk drive) and for various peripherals, some of which are always outside the computer such as printers.

The Patent requires "drivers" to be "customary." Again, the parties agree that the "input/output device" must be "customary in a host device." Since every input/output device has its own driver, for every input/output device that is "customary" there must also be a driver that is "customary." This explains the statement in the specification that "[d]rivers for I/O devices customary in a host device which are found in practically all host devices are, for example, drivers for hard disks, for graphics devices or for printer devices." '399 Patent, col. 4:27-30; '449 Patent, col. 3:31-34. Because all input/output devices must have individual drivers to function, and because Mr. Tasler referenced "customary input/output devices," the Court concludes that when he also referenced "drivers for the input/output device customary in a host device," he meant that such drivers themselves must be customary in a host device.

The question what does "in" a host device mean? is more difficult in the

context of the phrase “an input/output device customary in a host device.” The Camera Manufacturers again assert that “in” means “within the chassis of the host computer.” CMs’ *Markman* Br. 29. Papst suggests that an input/output device “in” a computer should be construed more broadly to mean “with respect to,” as in “a hardware device that inputs or outputs data with respect to a host computer.” Papst’s App. at 4. “We don’t read in as requiring it to be inside. It means part of the system.” Tr. 2:80 (Papst).

The parties’ conflicting interpretations arise from the garbled language of the Claims. The specification clarifies that drivers must be internal to the host device: “[d]rivers for I/O devices customary in a host device which are found in practically all host devices.” ’399 Patent, col. 4:27-30; ’449 Patent, col. 3:31-34. But in describing such drivers, the specification refers to drivers for printers. The parties agree that printers are not inside a computer. Tr. 2:80 (Papst); Tr. 2:87 (CMs).

The specification expressly defines “drivers customary in a host device” in relation to the devices that such drivers direct. Those devices described are both inside and outside a computer. However, the interface device “signals to the host device that it is an input/output device customary in a host device.” The phrase “customary in a host device” refers to the immediately antecedent noun “device;” there is no other antecedent word that the phrase reasonably could modify. Thus, the input/output must be “customary in a computer.” And the word “in” should be construed in accordance with its ordinary meaning to mean “within,” not “with respect to” as Papst proposes. Papst’s construction ignores the word “in,” rendering it superfluous, and such a construction is disfavored. *See Merck*, 395 F.3d at 1372 (a construction that gives meaning to all the terms of the claim is preferred over one that does not). Papst’s assertion that the Patent must mean input/output devices customary in a *computer system* because the specification refers to drivers for

devices both inside and outside the chassis of the computer might be what the inventor meant to say when he wrote his Patent. But the Patent does not say that the interface device “signals to the host device that it is an input/output device *for which the host device has drivers that are customary in a host device.*” The Court must construe the claims of the Patent as they are written.

Accordingly, the Court finds that “an input/output device customary in a host device” must be construed similarly to the phrase “the driver for the input/output device customary in a host device.” “An input/output device customary in a host device” in the ’399 Patent means a “data input/output device that was normally present within the chassis of most commercially available computers at the time of the invention,” and “the driver for the input/output device customary in a host device” means “the customary driver(s) in a host device used to communicate with customary internal and external input/output device(s), which driver(s) were normally present within the chassis of most commercially available computers at the time of the invention.” Thus, “a storage device customary in a host device” in the ’449 Patent means a “storage device that was normally present within the chassis of most commercially available computers at the time of the invention,” and “the driver for the storage device customary in a host device” means “the customary driver(s) in a host device used to communicate with customary internal and external storage device(s), which driver(s) were normally present within the chassis of most commercially available computers at the time of the invention.”

P. “the usual driver for the input/output [storage] device”

Claim Fourteen of the ’399 Patent and Claim Eighteen of the ’449 Patent both use the phrase “the usual driver for the input/output [storage] device” as follows:

regardless of the type of the data transmit/receive device attached to the second connecting device of the interface device, responding to

transmit/receive device and the host device.”

T. “virtual files”

Claim Seven of the '399 Patent provides, “An interface device according to claim 2, which further comprises a root directory and virtual files which are present on the signaled hard disk drive and which can be accessed from the host device.” '399 Patent, col. 13:33-36. Papst defines “virtual files” based on the type of media on which such files are stored as meaning “files which appear to be present on an emulated disk drive, yet which are not actually on a rotating disk.” Papst's App. at 5. The Camera Manufacturers offer instead that a “virtual file” is “a file that does not physically exist as a file in the interface device but appears to the host device to be an actual file, and references data to be transmitted between the data transmit/receive device and the host device.” CMs' *Markman Br.* at 38.

Claim Seven depends from Claim Two; under Claim Two, the interface device signals to the host device/computer that the interface device is a hard disk. *See* '399 Patent, col. 13:33 & 13-17. The “signaled hard disk drive” in Claim Seven refers back to the signal first mentioned in Claim Two. That signaled hard disk drive, which does not exist in fact, “further comprises a root directory and virtual files,” *id.*, col. 13:34, which also do not exist in fact.

The 1993 New IEEE Dictionary defined the term similarly to the construction proposed by the Camera Manufacturers. In the context of a “virtual record,” “virtual” was defined as: “a record that appears to be but is not physically stored; rather, it is constructed or derived from existing data when its contents are requested by an application program.” New IEEE Dictionary at 1461 (attached to CMs' *Markman Br.* as Ex. G); *see also* Oxford English Dictionary at 674 (2d ed. 1989) (defining “virtual” in the context of computers to mean “not physically existing as such but

made by software to appear to do so from the point of view of the program or the user”) (attached to CMs’ *Markman* Br. as Ex. P). The ’399 Patent and the specification do not indicate that Mr. Tasler used the term “virtual file” in any unique way, such as that proposed by Papst, and the Court construes the term to have its ordinary meaning.

Papst argues that if one interprets “virtual file” to mean “a file that does not physically exist as such but is made by software to appear to do so from the point of view of the program or the user,” Claim Seven would be inconsistent with Claims Eight, Nine, and Ten which, Papst asserts, cover “virtual files that are actually stored in the interface device.” Papst’s Reply at 35. Papst misreads these Claims. Each says, “wherein the virtual files comprise” a configuration file “stored in the memory means,” ’399 Patent, col. 13:38 (Claim Eight); batch files or executable files for the microprocessor “stored in the interface device,” *id.*, col. 13:43-44 (Claim Nine); and batch files or executable files for the host device “stored in the interface device.” *Id.*, col:13:48-49 (Claim Ten).

The Court perceives no conflict among the Claims. Virtual files that are “stored in the memory means” or “stored in the interface device” are no less virtual for that reason. Under Claims Eight, Nine, and Ten, what is “stored” are software instructions in the interface device which instruct the interface device to present data as if in real files of the types described, but which files are, in actuality, non-existent. The Court adopts the definition from the New IEEE Dictionary as the most clear and pertinent: “virtual files” in Claim Seven of the ’399 Patent means “files that appear to be but are not physically stored; rather, they are constructed or derived from existing data when their contents are requested by an application program so that they appear to exist as files from the point of view of the host device.”

U. “simulating a virtual file system”

The phrase “simulating a virtual file system” is found in Claim One of the ’449 Patent as follows: “wherein the interface device is arranged for simulating a virtual file system to the host, the virtual file system including a directory structure.” ’449 Patent, col. 12:4-6; *see also id.*, col. 14:4-7 (Claim Seventeen) (“the virtual file system including a file allocation table and a directory structure”); *id.*, col. 14:29-32 (Claim Eighteen) (same). The phrase might be thought a bit circuitous, in that a virtual file is already a simulated file. *See* Tr. 3:119 (Papst) (“[T]his is unusual language. It probably wouldn’t have been my first choice . . .”). With the additional word “system,” however, the phrase can be readily construed.

As Claims One, Seventeen, and Eighteen of the ’449 Patent make clear, the Patent covers a virtual system of files, with a virtual directory structure. *See* ’449 Patent, col. 12:6. Dependent Claim Two identifies additional types of virtual files which could be in the virtual system referenced in Claim One: a virtual configuration file, a virtual executable or batch file, or a virtual data file. *See id.*, col. 12:8-12; *see also id.* col. 12:27-28 (Claim Seven) (referencing a “virtual boot sequence”). A “virtual file system,” such as that described in the ’449 Patent, is one that is “not physically existing as such but made by software to appear to do so.” Oxford English Dictionary at 674 (defining “virtual” in the context of computers) (attached to CMs’ *Markman* Br. as Ex. P); *accord* New IEEE Dictionary at 1461 (“virtual record” is a record that “appears to be but is not physically stored”) (attached to CMs’ *Markman* Br. as Ex. G). The Court construes “simulating a virtual file system” to mean “appearing to be a system of files, including a directory structure, that is not physically stored; rather, it is constructed or derived from existing data when its contents are requested by an application program so that it appears to exist as a system of files from the point of

view of the host device.”

V. “specific driver for the multi-purpose interface”

Claim Eleven of the ’399 Patent states:

wherein the first command interpreter is configured in such a way that the command interpreter, when receiving an inquiry from the host device as to a type of a device attached to the multi-purpose interface of the host device, sends a signal, regardless of the type of the data transmit/receive device attached to the second connecting device of the interface device, to the host device which signals to the host device that it is an input/output device customary in a host device, whereupon the host device communicates with the interface device by means of *the specific driver for the multi-purpose interface*

’399 Patent, col. 14:4-15 (emphasis added). Claim Seventeen of the ’449 Patent cites the same phrase as:

wherein the interface device is configured using the processor and the memory in such a way that the interface device, when receiving an inquiry from the host device as to a type of a device attached to the multi-purpose interface of the host device, sends a signal, regardless of the type of the data transmit/receive device attached to the second connecting device of the interface device, to the host device which signals to the host device that it is a storage device customary in a host device, whereupon the host device communicates with the interface device by means of *the specific driver for the multi-purpose interface*

’449 Patent, col. 13:26-34 & col. 14:1-3 (emphasis added).

The Camera Manufacturers contend that “the specific driver for the multi-purpose interface” means the set of software routines that control the multi-purpose interface that are developed for the particular multi-purpose interface. CMs’ Slides at 240. Ignoring the word “specific,” Papst asserts that this means a driver for the multi-purpose interface, *i.e.*, a software driver that enables a host system to communicate via a multi-purpose interface. Papst’s App. at 5.

The specification explains why the word “specific” is used in these Claims:

input/output drivers customary in a host device comprise a hard disk driver, and the signal indicates to the host device that the host device is communicating with a hard disk.

'399 Patent, col. 13:13-17. Papst argues in its Reply that the Court should construe Claim Two of the '399 Patent, Papst's Reply at 31-32, but did not present any further argument on this issue at the hearing.²⁵ The Camera Manufacturers assert that there is no need to construe Claim Two because it consists of terms already construed in the context of Claim One. There is a presumption that the same term used in multiple claims has the same meaning. *See Fin Control Sys. Pty*, 265 F.3d at 1318. Because the Court already construed the component terms, it is not necessary to construe Claim Two.

IV. CONCLUSION

Accordingly, Papst's Motion for Reconsideration will be granted. The June 12, 2009, Memorandum Opinion and Order [Dkt. ## 312 & 313] will be vacated. The Claims of the Patents are deemed to have the meanings ascribed to them above. A memorializing Order accompanies this Memorandum Opinion.

Date: November 24, 2009

/s/
ROSEMARY M. COLLYER
United States District Judge

²⁵ Tr. 3:134 (Papst) ([W]e're considering whether or not to present further argument on hard disk drive which is in Claim 2"). None was presented.

UNITED STATES DISTRICT COURT
FOR THE DISTRICT OF COLUMBIA

**IN RE PAPST LICENSING GMBH & CO. KG
LITIGATION**

Misc. Action No. 07-493 (RMC)

MDL Docket No. 1880

This Document Relates To:

The First Wave Cases --

Fujifilm Corp. v. Papst, 07-cv-1118;
Matsushita Elec. Indus. Co., Ltd. v. Papst, 07-cv-1222;
Papst v. Olympus Corp., 07-cv-2086;
Papst v. Samsung Techwin Co., 07-cv-2088;
Papst v. Ricoh Co. Ltd., 07-cv-612;
Hewlett Packard Co. v. Papst, 08-cv-865; and
Papst v. Nikon Corp., 08-cv-985.¹

MODIFIED ORDER REGARDING CLAIMS CONSTRUCTION

For the reasons stated in the Memorandum Opinion filed simultaneously with this Order, it is hereby **ORDERED** that Papst’s Motion for Reconsideration [Dkt. # 321] is **GRANTED**; and it is

FURTHER ORDERED that the June 12, 2009 Memorandum Opinion and Order [Dkt. ## 312 & 313] are **VACATED**; and it is

FURTHER ORDERED that the Claims of U.S. Patent Nos. 6,470,399 (“ ’399

¹ This Order relates to the First Wave Cases listed in the caption. The Camera Manufacturers who are parties in the First Wave Cases include: Fujifilm Corporation; Fujifilm U.S.A., Inc.; Fujifilm Japan; Matsushita Electric Industrial Co., Ltd.; Victor Company of Japan, Ltd.; Olympus Corporation; Olympus Imaging America Inc.; Samsung Techwin Co.; Samsung Opto-Electronics America, Inc., Panasonic Corporation of North America; JVC Company of America; Ricoh Corporation; Ricoh Company Ltd.; Ricoh Americas Corporation; Hewlett-Packard Company; Nikon Corporation; and Nikon, Inc.

Patent”) and 6,895,449 (“ ’449 Patent”) (collectively the “Patents”) are construed as follows:

1. The term “interface device” means a “stand-alone device.”
2. The term “host device” means “a general purpose computer that connects to and directs the operation of peripherals, including drivers for input/output devices customary in a host device and a multi-purpose interface.”
3. The term “data transmit/receive device” means “a device that is capable of either (a) transmitting data to or (b) transmitting data to and receiving data from the host device when connected to the host device by the interface device.”
4. The phrase “for communication between” the host and the data transmit/receive device means “for transmitting data either (a) from the data transmit device to the host or (b) bidirectionally between the host and the transmit/receive device.”
5. The term “multi-purpose interface” means “a communication interface designed for use with multiple devices that can have different functions from each other.”
6. The word “interfacing” means “establishing communication with.”
7. The term “first connecting device” means “a physical socket or plug for permitting a user to attach and detach the interface device to and from a host device/computer.”
8. The term “second connecting device” in the ’399 Patent means “a physical plug or socket for permitting a user readily to attach and detach the interface device with a plurality of dissimilar data transmit/receive devices, including a sampling circuit for sampling the analog data provided by the data transmit/receive device and an analog-to-digital converter for converting data sampled by the sampling circuit into digital data.” In the ’449 Patent, the term “second connecting device” means “a physical plug or socket for permitting a user readily to attach and detach the interface device with a plurality of dissimilar data

transmit/receive devices.”

9. The term “first command interpreter” in the ’399 Patent means “a software program for interpreting an inquiry from a host device and sending a signal to the host device in response to the inquiry, which signal tells the host computer that the interface device is an input/output device customary in a host device regardless of the type of transmit/receive device attached to the interface device.”
10. The term “second command interpreter” in the ’399 Patent means “a software program for interpreting data request commands from the host device as data transfer commands.”
11. The phrase “[w]herein the interface device is configured by the processor and memory to include a first command interpreter and a second command interpreter” as used in the ’399 Patent means that “the processor of the interface device runs a program from its memory to determine the data transfer parameters of the interface device for the first and second command interpreters.”
12. The term “inquiry” means “an instruction seeking information concerning the type of the device attached to a computer” and the term “inquiring” means “sending an instruction seeking information concerning the type of the device attached to a computer.”
13. The word “driver” means “the set of software routines used to direct a device, for example, an input/output device or a multi-purpose interface.”
14. The phrase “an input/output device customary in a host device” in the ’399 Patent means a “data input/output device that was normally present within the chassis of most commercially available computers at the time of the invention” and the phrase “a storage device customary in a host device” in the ’449 Patent means a “storage device that was normally present within the chassis of most commercially available computers at the time of the invention.”

15. The phrase “the driver for the input/output device customary in a host device” in the ’399 Patent means “the customary driver(s) in a host device used to communicate with customary internal and external input/output device(s), which driver(s) were normally present within the chassis of most commercially available computers at the time of the invention,” and the phrase “the driver for the storage device customary in a host device” in the ’449 Patent means “the customary driver(s) in a host device used to communicate with customary internal and external storage device(s), which driver(s) were normally present within the chassis of most commercially available computers at the time of the invention.”
16. In Claim Fourteen of the ’399 Patent, the phrase “the usual driver for the input/output device” means “the customary driver(s) in a host device used to communicate with customary internal and external input/output device(s), which driver(s) were normally present within the chassis of most commercially available computers at the time of the invention.” In Claim Eighteen of the ’449 Patent, the phrase “the usual driver for the storage device” means “the customary driver(s) in a host device used to communicate with customary internal and external storage device(s), which driver(s) were normally present within the chassis of most commercially available computers at the time of the invention.”
17. The phrase “whereupon the host device communicates with the interface device by means of the driver for the input/output [storage] device customary in a host device” does not need to be construed separately from its constituent claim terms, which have already been construed.
18. The phrase “the digital data” as used in Claim One of the ’399 Patent means “the data as it is output by the analog to digital converter, and/or the data as it is output by the analog to digital converter after it has undergone additional processing, such as digital signal

processing.”

19. The Court construes “a buffer” (for buffering data as set forth in Claim Three of the ’399 Patent) and “a data buffer” (as set forth in Claim Sixteen of the ’449 Patent) as “memory used to store data temporarily to compensate for differences between the rate in the flow of data between the data transmit/receive device and the host device.”
20. The term “virtual files” in Claim Seven of the ’399 Patent means “files that appear to be but are not physically stored; rather, they are constructed or derived from existing data when their contents are requested by an application program so that they appear to exist as files from the point of view of the host device.”
21. The phrase “simulating a virtual file system” in Claim One of the ’449 Patent means “appearing to be a system of files, including a directory structure, that is not physically stored; rather, it is constructed or derived from existing data when its contents are requested by an application program so that it appears to exist as a system of files from the point of view of the host device.”
22. “Specific driver for the multi-purpose interface” as used in Claim Eleven of the ’399 Patent and Claim Seventeen of the ’449 Patent means “the set of software routines that control the multi-purpose interface and that are developed for the particular multi-purpose interface.”
23. A “digital signal processor” as specified in Claim Five of the ’399 Patent means a “processor optimized to perform repetitive computations used in digital signal processing such as multiply-accumulates.”
24. The word “memory” means “any type of memory.”
25. The term “root directory” means “a directory that is not in another directory” and the term “processor” means “any kind of microprocessor, including a digital signal processor.”

26. Claim Two of the '399 Patent does not need to be construed separately from its constituent claim terms, which have already been construed.

SO ORDERED.

Date: November 24, 2009

/s/
ROSEMARY M. COLLYER
United States District Judge

UNITED STATES DISTRICT COURT
FOR THE DISTRICT OF COLUMBIA

_____)	
IN RE PAPST LICENSING GMBH & CO. KG)	
LITIGATION)	
_____)	
This document relates to)	Misc. Action No. 07-493 (RMC)
_____)	
ALL CASES)	MDL No. 1880
_____)	
_____)	
_____)	
_____)	

MEMORANDUM OPINION RE: CAMERA MANUFACTURERS’ MOTION FOR SUMMARY JUDGMENT REGARDING MEMORY CARDS

Papst Licensing GmbH & Co. KG, a German company, sues multiple manufacturers of digital cameras for alleged infringement of two patents owned by Papst: U.S. Patent Number 6,470,399 (399 Patent) and U.S. Patent Number 6,895,449 (449 Patent).

Generally, Papst contends that digital cameras are “interface devices” that infringe the Patents.

The Camera Manufacturers¹ move for summary judgment of noninfringement based on Papst’s infringement allegations that memory cards are both the “memory” of certain

¹ This Multi District Litigation currently consists of First and Second Wave Cases. The “First Wave Cases” are: *Fujifilm Corp. v. Papst*, 07-cv-1118; *Matsushita Elec. Indus. Co., Ltd. v. Papst*, 07-cv-1222; *Papst v. Olympus Corp.*, 07-cv-2086; *Papst v. Samsung Techwin Co.*, 07-cv-2088; *Hewlett-Packard Co. v. Papst*, 08-cv-865; and *Papst v. Nikon Corp.*, 08-cv-985. The “Second Wave Cases” currently are: *Papst v. Canon*, 08-cv-1406; *Papst v. Eastman Kodak*, 08-cv-1407; *Papst v. Sanyo*, 09-cv-530. The Camera Manufacturers seeking summary judgment here are parties in the First Wave Cases; they are: Fujifilm Corporation; Fujifilm U.S.A., Inc.; Fujifilm Japan; Matsushita Electric Industrial Co., Ltd.; Victor Company of Japan, Ltd.; Olympus Corporation; Olympus Imaging America Inc.; Samsung Techwin Co., Ltd.; Samsung Opto-Electronics America, Inc.; Panasonic Corporation of North America; JVC Company of America; Hewlett-Packard Company (HP); Nikon Corporation; and Nikon, Inc. Papst’s infringement contentions against HP have been stricken and discovery has been stayed.

accused devices and also “data transmit/receive devices” that can be attached to the accused cameras. Because the invented “interface device” is a stand-alone device that is separate and apart from any data transmit/receive device, the Camera Manufacturers contend that a memory card cannot be both part of the interface device and a data transmit/receive device as Papst alleges. The Court agrees. The motion for summary judgment will be granted.

I. FACTS

The invention at issue is a “Flexible Interface for Communication Between a Host and an Analog I/O Device Connected to the Interface Regardless of the Type of the I/O Device.” 399 Patent, Title; 449 Patent, Title. An I/O device is an input/output device, repeatedly referred to as a “data transmit/receive device” in the Patents. *See, e.g.*, 399 Patent 3:43-44 & 13:1-2; 449 Patent 4:6-7 & 11:63-64.² The 399 Patent was issued on October 22, 2002, with an application date of March 3, 1998; the 449 Patent was issued on May 17, 2005, with an application date of August 15, 2002. The patented “Flexible Interface Device” was invented by Michael Tasler; it has never been manufactured. Papst now owns the Patents.

The 449 Patent is a continuation or divisional patent³ that is quite similar to the 399 Patent. The Patents share the same block diagram drawings, Figures 1 and 2. *See, e.g.*, 399 Patent 9:15-16 (“Figure 2 shows a detailed block diagram of an interface device, according to the present invention”); 449 Patent 8:15-16 (same). The 399 and 449 Patents also share much of the same specification. Even so, the 449 Patent covers other aspects of the invention; as relevant to this Opinion, one key difference is that the 449 Patent omits references to analog-to-digital data conversion.

² Citations to the Patents are to “column number: line number.”

³ As a continuation patent, Papst asserts that the 449 Patent has priority dating back to the 399 Patent.

The invention, a flexible “interface device,” was designed to provide data transfer between a transmit/receive device and a computer (host device) without the need for special software; this is accomplished by telling the computer that the interface device is an I/O device already known to the computer (and for which the computer already has drivers), regardless of what kind of I/O device actually is attached to the interface device. 449 Patent, Abstract; 399 Patent, Abstract; *see also* 449 Patent 5:19-22 (in the preferred embodiment, “[r]egardless of which data transmit/receive device at the output line 16 is attached to the second connecting device, the digital signal processor 13⁴ informs the host device that it is communicating with a hard disk drive”); 399 Patent 6:19-22 (same). The invention is to provide “an interface device for communication between a host device and a data transmit/receive device whose use is host device-independent and which delivers a high data transfer rate.” 449 Patent 3:20-23; 399 Patent 3:24-27. The Patents are “based on the finding that both a high data transfer rate and host device-independent use can be achieved if a driver for an input/output device customary in a host device, normally present in most commercially available host devices, is utilized,” instead of special driver software. 449 Patent 3:27-31; 399 Patent 4:23-27. In other words, the invention seeks to capitalize on software customarily found in a computer to allow communication with a data transmit/receive device.

Pursuant to *Markman v. Westview Instruments, Inc.*, 517 U.S. 370 (1996), a court is required to construe the contested claims of the patents before a jury can determine whether the accused products infringe. In claims construction, a court must interpret the words of each contested claim from the perspective of one skilled in the art at the time of invention, in light of the patent documents and the prosecution history. *Phillips v. AWH Corp.*, 415 F.3d 1303, 1313

⁴ The specification often refers to block diagrams, Figures 1 and 2, by identifying elements by number as they appear in the Figures.

(Fed. Cir. 2005). The Court construed the contested claims of the 399 and 449 Patents. *See* Modified Claims Construction Opinion [Dkt. 336] (Claims Constr. Op.); Order [Dkt. 337].

Claim One of the 449 Patent states:

What is claimed is:

1. An *interface device* for communication between a host device, which comprises drivers for input/output devices customary in a host device and a multi-purpose interface, and a data transmit/receive device comprising the following features:

a processor;

a *memory*;

a first connecting device for interfacing the host device with the interface device via the multi-purpose interface of the host device; and

a second connecting device for interfacing the interface device with the data transmit/receive device,

wherein the interface device is configured by the processor and the memory in such a way that the interface device, when receiving an inquiry from the host device as to the type of a device attached to the multi-purpose interface of the host device, sends a signal, *regardless of the type of the data transmit/receive device attached* to the second connecting device of the interface device, to the host device which signals to the host device that it is a storage device customary in a host device, whereupon the host device communicates with the interface device by means of the driver for the storage device customary in a host device, and

wherein the interface device is arranged for simulating a virtual file system to the host, the virtual file system including a directory structure.

449 Patent 11:45-67 & 12:1-6 (emphasis added); *see also* 399 Patent 12:41-67 & 13:1-13 (as relevant here, substantially the same as the 449 Patent, except that the “data transmit/receive device” is described as “being arranged for providing analog data”).

During claims construction, the Court determined that the invented “interface device” is a “stand-alone” device. Claims Constr. Op. at 18. The Court expressly noted: “That the data transmit/receive device must be a separate device from the invention is not mere happenstance but an integral aspect of what was invented.” *Id.* at 19. The Court also explained that the interface device can be *attached* to separate data transmit/receive devices. *Id.* at 19, 21; *see* 449 Patent 6:40-43 (because an operator could program the interface device, users could “perform essentially identical operator actions for almost any data transmit/receive devices which *can be attached* to the second connecting device via the line 16” (emphasis added)); 399 Patent 7:40-43 (same). Further, the Court found that the language in Claim One stating “regardless of the type of the data transmit/receive device attached” indicates that various kinds of data transmit/receive devices can be attached and that, therefore, the interface device was not a permanent part of either the data transmit/receive device or the host device/computer. Claims Constr. Op. at 19; *see* 449 Patent 11:59-67 (“the interface device . . . sends a signal, *regardless of the type of the data transmit/receive device attached* to . . . the interface device . . . , to the host device which signals to the host device that it is a storage device customary in a host device . . .” (emphasis added)); 399 Patent 13:1-5 (highlighted portion the same; substituting the term “input/output device” for the term “storage device”).

In explaining that the interface device “stands alone,” the Court noted that the Figures that accompany each Patent indicate that “the data transmit/receive device is off the sheet, out of sight, not part of the Figure, and not part of the invention.” Claims Constr. Op. at 22. Thus, “Claim One contemplates and intends that a variety of transmit/receive devices may be connected to the interface device, which is also connected to the computer. To fulfill Claim One, the ‘interface device’ must, therefore, be a ‘stand-alone device.’” *Id.* at 24.

Further, Claim One of the Patents describes the interface device as having a memory, meaning “any type of memory.” *Id.* at 73. In addition, the Court construed the term “data transmit/receive device” to mean “a device that is capable of either (a) transmitting data to or (b) transmitting data to and receiving data from the host device when connected to the host device by the interface device.” *Id.* at 31. In sum, the “interface device” claimed in the Patents is, in relevant part, (1) a stand-alone device (2) that has a memory and that (3) connects to a separate data transmit/receive device for the purpose of data transfer between a transmit/receive device and a computer, without the need for special software.

Memory cards used in digital cameras and other accused devices are detachable; they can be inserted into slots on many of the accused products. They are thus distinguishable from internal memory, which is nondetachable. As described in detail below, Papst identified memory cards as both the “memory” of accused devices and a “data transmit/receive device” to which an accused device may attach.

II. LEGAL STANDARD

Under Rule 56 of the Federal Rules of Civil Procedure, summary judgment shall be granted “if the movant shows that there is no genuine dispute as to any material fact and the movant is entitled to judgment as a matter of law.” Fed. R. Civ. P. 56(a); *accord Anderson v. Liberty Lobby, Inc.*, 477 U.S. 242, 247 (1986). Moreover, summary judgment is properly granted against a party who “after adequate time for discovery and upon motion . . . fails to make a showing sufficient to establish the existence of an element essential to that party’s case, and on which that party will bear the burden of proof at trial.” *Celotex Corp. v. Catrett*, 477 U.S. 317, 322 (1986).

In ruling on a motion for summary judgment, the court must draw all justifiable inferences in the nonmoving party's favor. *Anderson*, 477 U.S. at 255. A nonmoving party, however, must establish more than “the mere existence of a scintilla of evidence” in support of its position. *Id.* at 252. The nonmoving party must point out specific facts showing that there is a genuine issue for trial. *Celotex*, 477 U.S. at 324. In addition, the nonmoving party may not rely solely on allegations or conclusory statements. *Greene v. Dalton*, 164 F.3d 671, 675 (D.C. Cir. 1999). Rather, the nonmoving party must present specific facts that would enable a reasonable jury to find in its favor. *Id.* at 675. If the evidence “is merely colorable, or is not significantly probative, summary judgment may be granted.” *Anderson*, 477 U.S. at 249-50 (citations omitted). Summary judgment can be granted in a patent case if there is no dispute over the structure of the accused products, at which point the question of infringement “collapses” into the question of claim construction and may be resolved by the court. *Desper Prods. Inc. v. QSound Labs Inc.*, 157 F.3d 1325, 1332-33 (Fed. Cir. 1998).

III. ANALYSIS

A. 399 Patent

Because memory cards provide digital and not analog data, Papst withdrew its assertion that memory cards constitute “data transmit/receive devices” for the purpose of the 399 Patent, which requires the data transmit/receive device to send analog data. Opp. Re Memory Cards [Dkt. 480] at 3 n.2 (“Papst withdraws its assertion that memory cards constitute DTRDs [data transmit/receive devices] for purposes of the 399 [P]atent that calls for the DTRD to input analog data.”); *see also* Opp. HP’s Mot. Summ. J. [Dkt. 470] at 25 (accused cameras that receive digital data, and not analog data, from memory cards and USB connectors do not infringe the

399 Patent).⁵ Accordingly, summary judgment of noninfringement of the 399 Patent will be granted to the Camera Manufacturers as to Papst's claim that memory cards are data transmit/receive devices.⁶

B. 449 Patent

The Court thus turns solely to the 449 Patent. To prove literal infringement, a patentee must prove that the accused product satisfies each and every limitation of a claim. *Warner-Jenkinson Co. v. Hilton-Davis Chem. Co.*, 520 U.S. 17, 29 (1997); *Rohm & Haas v. Brotech Corp.*, 127 F.3d 1089, 1092 (Fed. Cir. 1997). The accused products include digital cameras and other devices that Papst asserts are "interface devices" that infringe the 449 Patent.

As described above, Claim One of the 449 Patent claims an "interface device," which has a "memory" and interfaces with a "data transmit/receive device." Papst claims that the accused devices are interface devices that satisfy the limitations of the 449 Patent and, therefore, infringe. *See generally* Final Infringement Contentions [Dkt. 416] (FICs). Papst's Final Infringement Contentions, however, are inconsistent with the Court's construction of the claims. To support its contention that cameras constitute "interface devices," Papst contends that memory cards are part of the "memory" of the cameras and that memory cards constitute "data transmit/receive devices" that can be attached to the cameras. In other words, Papst claims that certain accused devices include memory cards that constitute *both* the "memory" of the accused devices *and* the "data transmit/receive device" that exchanges data with the accused devices.

This is not a viable infringement claim under the Court's claims construction.

⁵ The "second connecting device" in the 399 Patent receives analog data from the data transmit/receive device. *See* Claims Constr. Op. at 40.

⁶ Papst moved for more discovery on the memory card issue, *see* Mot. for Rule 56(d) Discovery [Dkt. 479], but later withdrew that portion of its motion. *See* Reply in Support of Mot. for Rule 56(d) Discovery [Dkt. 515] at 1.

The Final Infringement Contentions repeatedly assert that many of the accused devices meet the memory claim limitation because they “include a memory card”:

Certain devices in suit have no internal flash memory for storage of images or other data. Such devices nevertheless have other memory, including RAM and memory for storage of device firmware. Additionally, *such devices include a memory card and instructions for a consumer to install the memory card in the device. The device has no substantial use without installation of the memory card as directed.* Accordingly, such devices literally infringe under 35 U.S.C. § 271(a) or, in the alternative, indirectly infringe under 35 U.S.C. § 271(b)-(c).

FICs at 19-20 (Part C, “Memory”) (emphasis added); *see also* FICs at 61 & 66 (claiming that the “memory” limitation is satisfied because “the interface portion of MSC Capable Devices addressed herein include memories. Also, a socket is typically provided for adding a memory card.”) Papst concedes that many of the accused products have no internal flash memory for storage of image and movie files and thus have “no substantial use without installation of the memory card.” *Id.* at 19-20.⁷

In its Final Infringement Contentions, Papst also accuses various products of infringement based on the theory that memory cards are data transmit/receive devices.

MSC Capable Devices and PTP Capable Devices typically include a physical plug or socket for receiving a memory card. . . . For example, SD Card connectors also support Secure Digital Input/Output (“SDIO” devices). An SDIO device is based on, and is compatible with, the SD Memory Card connector. The

⁷ Many of the accused products have no internal memory and can only store files on a memory card. Other accused devices have internal memory of varying capacities. The Final Infringement Contentions do not treat products without internal memory for storing images differently from products with internal memory. Whether accused devices with nondetachable memory meet the claim limitations of the Patents is not addressed here, as it is not relevant to the motion for summary judgment based on “memory cards.” Similarly, Papst’s contention that fact issues preclude summary judgment because it cannot discern how nondetachable memory works has no relevance to the argument regarding detachable memory cards.

compatibility includes mechanical, electrical, power, signaling and software. SDIO cards have many dissimilar functions. Some SDIO cards have interfaces which obtain information and store it in memory on the card, which may be accessed by an interface device of the devices-in-suit. For example, an “Eye-Fi” Card device may be a data transmit/receive device because it obtains certain information wirelessly and stores a portion of it in memory. Additional discovery of multi-function memory cards is required. The memory may be accessed by a host computer when the device is connected to the USB interface of the host computer. The Compact Flash (“CF”) Card connectors also allow connection of numerous dissimilar devices. The memory card connectors may therefore allow a user to readily attach or detach a plurality of dissimilar devices. Devices having connectors for memory cards are identified in . . . table 5 below.

FICs at 25. Table 5 of the Final Infringement Contentions, entitled “Devices having memory card connectors,” lists numerous accused products that have memory card slots for connection to various types of memory cards, including SD (Secure Digital) devices, CF (CompactFlash) devices, XD devices, and SmartMedia devices. *Id.* at 93-124 (Table 5).

Papst’s Final Infringement Contentions are inconsistent regarding its claim of infringement based on the use of memory cards by accused devices. A memory card cannot be *both* a data transmit/receive device and part of an interface device. The Court made clear in its claims construction opinion that the interface device is separate and distinct from the data transmit/receive device. The block diagram Figures that accompany each Patent indicate that “the data transmit/receive device is off the sheet, out of sight, not part of the Figure, and not part of the invention.” Claims Constr. Op. at 22. The basic function of the invention was to facilitate fast communication between dissimilar data transmit/receive devices and a computer. *See* 449 Patent 3:20-23 (the invention is “an interface device for communication between a host device and a data transmit/receive device whose use is host device-independent and which delivers a high data transfer rate”). The interface device claimed in the Patent does not include the dissimilar data transmit/receive devices; the Patent describes data transmit/receive devices as

something to which the interface device is “attached.” *See* Claims Constr. Op. at 19-21; *see* 449 Patent 6:40-43 (users could “perform essentially identical operator actions for almost any data transmit/receive devices which *can be attached* to the second connecting device via the line 16” (emphasis added)); 449 Patent 11:59-67 (“the interface device . . . sends a signal, *regardless of the type of the data transmit/receive device attached* to the second connecting device of the interface device . . .” (emphasis added)). Even the title of the invention—“Flexible Interface for Communication Between a Host and an Analog I/O Device Connected to the Interface Regardless of the Type of the I/O Device”—refers to communication between a computer and a data transmit/receive device connected to (and not a part of) the interface device. *See* 449 Patent, Title.

The interface device stands alone. Papst’s claim—that accused products infringe because they use memory cards which satisfy the “memory” limitation *and* which satisfy the “data transmit/receive device” limitation of the Patent—fails because it is contrary to the 449 Patent and the Court’s construction of its fundamental aspects.

It does not matter that the Final Infringement Contentions include allegations that some accused devices use multiple function memory cards, such as Eye-Fi and SDIO Cards, which include memory plus transmit/receive functions. *See* FICs at 9, 25. If any part of the memory card is part of the interface device, the memory card cannot be (in whole or in part) the “data transmit/receive device.”

Papst seeks to escape its own Final Infringement Contentions by now contending that memory cards “are believed not to be required to perform the functions recited in the claims.” *See* Opp. at 1. Papst’s entire Opposition disavows reliance on memory cards to fulfill the required “memory” claim of the interface device. *See id.* at 11 (“It is the processor and the

non-detachable memory that perform the functions required by the claims. The detachable memory is not where those functions are performed.” (citation omitted)).

Papst might intend to assert some new theory of infringement. However, it is years too late for new theories. The Court ordered Papst to file final infringement contentions in compliance with detailed requirements. *See* Mot. for Sanctions [Dkt. 388], Ex. A (Tr. of Aug. 31, 2010 Hearing); Sixth Prac. & Pro. Order (Sixth PPO) [Dkt. 372]. Because Papst filed Final Infringement Contentions that failed to comply with Court’s orders, the Court barred Papst from advancing any arguments for infringement (or against claims of noninfringement) that either (1) are not based solely on this Court’s constructions of the Patents or (2) are not already set forth specifically and explicitly in Papst’s Final Infringement Contentions. *See* Sanctions Op. [Dkt. 429] at 13; Sanctions Order [Dkt. 430] at 2. In the instant motion for summary judgment, the Camera Manufacturers have pointed out that the Final Infringement Contentions include a claim for infringement (based on memory cards as both “memory” and “data transmit/receive device”) that is outside the parameters of the Court’s construction of the Patent. Because it does not comport with the Court’s claim construction, this theory of infringement fails.

C. Doctrine of Equivalents

The doctrine of equivalents is inapplicable here. The essential inquiry in a determination under the doctrine of equivalents is whether “the accused product or process contains elements identical or equivalent to each claimed element of the patented invention.” *Am. Calcar, Inc. v. Am. Honda Motor Co.*, 651 F.3d 1318, 1338 (Fed. Cir. 2011) (quoting *Warner-Jenkinson*, 520 U.S. at 40). An element in an accused product is deemed to be equivalent to a claim limitation if the difference between the two is “insubstantial” to a person of ordinary skill in the art. *Wavetronix v. EIS Elec. Integrated Sys.*, 573 F.3d 1343, 1360 (Fed. Cir.

2009). In order to assess insubstantiality, a court considers whether an element of the accused product “performs substantially the same function in substantially the same way to obtain the same result” as the patented invention. *Am. Calcar*, 651 F.3d at 1338. This is often referred to as the “function/way/result test.” *Id.* A patentee alleging infringement under the doctrine of equivalents must submit particularized evidence of equivalence and must explain specifically why the difference between what the claims literally require and what the accused products actually do is “insubstantial.” *Id.*

Papst’s Final Infringement Contentions fail to assert any claims regarding memory cards and the doctrine of equivalents. As explained above, Papst failed to comply with Court orders and the Court imposed a sanction. Papst is precluded from advancing any arguments for infringement (or against claims of noninfringement) that either (1) are not based solely on this Court’s constructions of the Patents or (2) are not already set forth specifically and explicitly in Papst’s Final Infringement Contentions. *See* Sanctions Op. [Dkt. 429] at 13; Sanctions Order [Dkt. 430] at 2. Accordingly, Papst cannot now add a claim for infringement under the doctrine of equivalents.⁸

Moreover, the doctrine of equivalents may not be used to recapture a disavowed claim. *Sunbeam Prods. Inc. v. Homedics, Inc.*, 412 F. App’x 263, 268 (Fed. Cir. 2010); *see also Phillips*, 415 F.3d at 1316 (a specification may reveal an intentional disclaimer); *J & M Corp. v. Harley-Davidson, Inc.*, 269 F.3d 1360, 1366 (Fed. Cir. 2001) (the scope of equivalents may be limited by disclaimers in the specification). “When a patent thus describes the features of the

⁸ Further, Papst’s opposition to the motion for summary makes only the bald assertion that the Camera Manufacturers “infringe under the doctrine of equivalents.” *See* Opp. at 33. Papst’s vague and conclusory contention that the accused devices infringe under the doctrine equivalents via their use of memory cards does not satisfy the level of specificity that the Court required, and thus Papst has waived such a claim. *See* Sanctions Op. at 7-13.

‘present invention’ as a whole, this description limits the scope of the invention.” *Verizon Servs. Corp. v. Vonage Holdings Corp.*, 503 F.3d 1295, 1308 (Fed. Cir. 2007). The specification of the 449 Patent describes “*the invention*” as separate from the data transmit/receive device:

In the interface device according to *the present invention* an enormous advantage is to be gained, as apparent in the embodiment described in the following, *in separating the actual hardware required to attach the interface device 10 to the data transmit/receive device*

449 Patent 7:23-27 (emphases added). Papst’s infringement claim regarding memory cards is not saved from dismissal based on the doctrine of equivalents.

IV. CONCLUSION

The Camera Manufacturers’ motion for summary judgment of noninfringement on the basis of memory cards [Dkt. 446] will be granted.⁹ Memory cards do not produce analog data, and thus they cannot constitute a “data transmit/receive device” that would lead to infringement of the 399 Patent. Further, memory cards cannot be both the “memory” of an accused device and the “data transmit/receive device” to which an accused device may be attached. *See* Claims Constr. Op. at 16-24. Summary judgment will be granted in favor of the Camera Manufacturers with regard to all such infringement claims. The products identified in Papst’s Final Infringement Contentions do not infringe the claims of the 399 or the 449 Patents either literally or under the doctrine of equivalents based on memory cards (including ordinary memory cards, SD (Secure Digital) devices, CF (CompactFlash) devices, XD devices, SmartMedia devices, SDIO cards, and Eye-Fi cards) because such memory cards do not meet the

⁹ Papst moved to file a surreply in opposition to the Camera Manufacturers’ motion for summary judgment regarding memory cards. *See* Mot. for Leave to File Surreply [Dkt. 511]. Because surreplies are disfavored in this district and because the Camera Manufacturers’ reply brief did not raise new issues, the motion to file a surreply will be denied. *See Crummey v. Social Security Admin.*, 794 F. Supp. 2d 46, 62 (D.D.C. 2011).

UNITED STATES DISTRICT COURT
FOR THE DISTRICT OF COLUMBIA

_____)		
IN RE PAPST LICENSING GMBH & CO. KG))	
LITIGATION))	
)	Misc. Action No. 07-493 (RMC)
This document relates to))	
)	MDL No. 1880
ALL CASES))	
)	
)	
_____))	

MEMORANDUM OPINION RE: CAMERA MANUFACTURERS’ MOTION FOR
SUMMARY JUDGMENT OF NONINFRINGEMENT WITH RESPECT TO THE
“DATA TRANSMIT/RECEIVE DEVICE” CLAIM LIMITATION

Papst Licensing GmbH & Co. KG, a German company, sues multiple manufacturers of digital cameras for alleged infringement of two patents owned by Papst: U.S. Patent Number 6,470,399 (399 Patent) and U.S. Patent Number 6,895,449 (449 Patent). The Camera Manufacturers¹ have moved for summary judgment of noninfringement with respect to the “data transmit/receive device” claim limitation in both Patents, asserting that when accused devices (basically, digital cameras) operate in Universal Serial Bus (USB) Mass Storage Class

¹ This Multi District Litigation currently consists of First and Second Wave Cases. The “First Wave Cases” are: *Fujifilm Corp. v. Papst*, 07-cv-1118; *Matsushita Elec. Indus. Co., Ltd. v. Papst*, 07-cv-1222; *Papst v. Olympus Corp.*, 07-cv-2086; *Papst v. Samsung Techwin Co.*, 07-cv-2088; *Hewlett-Packard Co. v. Papst*, 08-cv-865; and *Papst v. Nikon Corp.*, 08-cv-985. The “Second Wave Cases” currently are: *Papst v. Canon*, 08-cv-1406; *Papst v. Eastman Kodak*, 08-cv-1407; *Papst v. Sanyo*, 09-cv-530. The Camera Manufacturers seeking summary judgment here are parties in the First Wave Cases; they are: Fujifilm Corporation; Fujifilm U.S.A., Inc.; Fujifilm Japan; Matsushita Electric Industrial Co., Ltd.; Victor Company of Japan, Ltd.; Olympus Corporation; Olympus Imaging America Inc.; Samsung Techwin Co., Ltd.; Samsung Opto-Electronics America, Inc.; Panasonic Corporation of North America; JVC Company of America; Hewlett-Packard Company (HP); Nikon Corporation; and Nikon, Inc. Papst’s infringement contentions against HP have been stricken and discovery has been stayed.

(MSC) mode they do not infringe the Patents as alleged. Papst contends that specific external accessories such as lenses, flashes, GPS units, and printers constitute data transmit/receive devices within the meaning of the Patents because such accessories can transmit data to a computer via a camera operating in MSC mode. However, Papst fails to back up its argument with any evidence that contravenes the Camera Manufacturers' evidence that when the accused cameras are connected to a computer in MSC mode, the specified accessories do not and cannot transmit any data through the camera to the computer. Thus, such accessories do not and cannot meet the "data transmit/receive device" limitation in the Patents when the camera is in MSC mode. Papst fails to point to any genuine disputes over issues of material fact. The Camera Manufacturers' motion for summary judgment will be granted.

I. FACTS²

Papst alleges that certain accused devices manufactured and/or sold by the Camera Manufacturers are "interface devices" that infringe Claims 1-3, 5, 7, 11, and 14-15 of the 399 Patent and Claims 1-2, 6-9, 12-13, and 15-18 of the 449 Patent. The accused products include digital cameras, camcorders, and digital voice recorders.

Each of the asserted Patent Claims requires a "data transmit/receive device" that can transmit data to a computer via the invention, an "interface device." For example, Claim 1 of the 449 Patent states:

What is claimed is:

1. An interface device for communication between a host device, which comprises drivers for input/output devices customary in a

² This motion is one of eight filed by the Camera Manufacturers. In the interest of timely disposition of all, the Court does not recite the full background and assumes familiarity with its prior rulings. *See, e.g.*, Modified Claims Construction Op. [Dkt. 336]; Sanctions Op. [Dkt. 429].

host device and a multi-purpose interface, and a *data transmit/receive device* comprising the following features:

a processor;

a memory;

a first connecting device for interfacing the host device with the interface device via the multi-purpose interface of the host device; and

a second connecting device for interfacing the interface device with the data transmit/receive device,

wherein the interface device is configured by the processor and the memory in such a way that the interface device, when receiving an inquiry from the host device as to the type of a device attached to the multi-purpose interface of the host device, sends a signal, regardless of the type of the *data transmit/receive device* attached to the second connecting device of the interface device, to the host device which signals to the host device that it is a storage device customary in a host device, whereupon the host device communicates with the interface device by means of the driver for the storage device customary in a host device, and

wherein the interface device is arranged for simulating a virtual file system to the host, the virtual file system including a directory structure.

449 Patent, Claim 1, 11:45-67 & 12:1-6 (emphases added); 399 Patent, Claim 1, 12:41-67 & 13:1-13 (as relevant here, the same as the 449 Patent).³

The Court construed the contested claims of the 399 and 449 Patents, finding that the term “data transmit/receive device” means “a device that is capable of either (a) transmitting data to or (b) transmitting data to and receiving data from the host device *when connected to the host device by the interface device.*” Modified Claims Construction Op. [Dkt. 336] (Claims

³ Citations to the Patents are to “column number: line number.” The “interface device” was invented and patented by Michael Tasler, who sold the Patents to Papst. The invention was never produced or used.

Constr. Op.) at 31 (emphasis added); *see also* Order [Dkt. 337] at 2.⁴ The immediate motion for summary judgment is based on the “data transmit/receive device” claim limitation and the Court’s determination that a data transmit/receive device is a device capable of data transmission “when connected to the host device by the interface device” — that is, when the data transmit/receive device is attached to the invented interface device and thereby connected to the host computer.

The invention at issue is a “Flexible Interface for Communication Between a Host and an Analog I/O Device Connected to the Interface Regardless of the Type of the I/O Device.” 399 Patent, Title; 449 Patent, Title. An I/O device is an input/output device, repeatedly referred to as a “data transmit/receive device” in the Patents. *See, e.g.*, 399 Patent 3:43-44 & 13:1-2; 449 Patent 4:6-7 & 11:63-64. A “host” is a computer. The 449 Patent is a continuation or divisional patent⁵ that is quite similar to the 399 Patent. They share the same block diagram drawings, Figures 1 and 2. *See, e.g.*, 399 Patent 9:15-16 (“Figure 2 shows a detailed block diagram of an interface device, according to the present invention”); 449 Patent 8:15-16 (same). The 399 and 449 Patents also share much of the same specification.

The “interface device” is designed to provide data transfer between a data transmit/receive device and a computer without the need for special software; this is

⁴ The contested terms were almost entirely within Claim One of each Patent. Pursuant to *Markman v. Westview Instruments, Inc.*, 517 U.S. 370 (1996), a court is required to construe the contested claims of the patents before a jury can determine whether the accused products infringe. In claims construction, a court must interpret the words of each contested claim from the perspective of one skilled in the art at the time of invention, in light of the patent documents and the prosecution history. *Phillips v. AWH Corp.*, 415 F.3d 1303, 1313 (Fed. Cir. 2005).

⁵ The 399 Patent was issued on October 22, 2002, with an application date of March 3, 1998; the 449 Patent was issued on May 17, 2005, with an application date of August 15, 2002. Because it is a continuation patent, Papst asserts that the 449 Patent has priority dating back to the 399 Patent.

accomplished by telling the computer that the interface device is a transmit/receive device already known to the computer (and for which the computer already has drivers, i.e., software), regardless of what kind of data transmit/receive device actually is attached to the interface device. 399 Patent, Abstract; 449 Patent, Abstract. The Patents are “based on the finding that both a high data transfer rate and host device-independent use can be achieved if a driver for an input/output device customary in a host device, normally present in most commercially available host devices, is utilized,” instead of special driver software. 399 Patent 4:23-27; 449 Patent 3:27-31 (same); *see also* 399 Patent 6:19-22 (in the preferred embodiment, “[r]egardless of which data transmit/receive device at the output line 16 is attached to the second connecting device, the digital signal processor 13 informs the host device that it is communicating with a hard disk drive”); 499 Patent 5:19-22 (same).⁶ Thus, the purpose of the invention is “to allow fast communication between dissimilar data transmit/receive devices and computers, without the need for special software drivers.” Claims Constr. Op. at 22; *see* 399 Patent 3:24-27 (the purpose of the invention is to provide “communication between a host device and a data transmit/receive device whose use is host device-independent and which delivers a high data transfer rate”); 449 Patent 3:20-23 (same).

The Court determined that the Claims in both Patents provide that the data transmit/receive device is *attached* to the interface device *when* the computer initiates a data transfer from the data transmit/receive device. For example, Claim One of the 449 Patent states:

wherein the interface device is configured by the processor and the memory in such a way that the interface device, when receiving an inquiry from the host device as to the type of a device *attached* to the multi-purpose interface of the host device, sends a signal, *regardless of the type of the data transmit/receive device attached*

⁶ The specification often refers to Figures 1 and 2 by identifying numbered elements as they appear in the Figures.

to the second connecting device of the interface device, to the host device which signals to the host device that it is a storage device customary in a host device, *whereupon the host device communicates with the interface device* by means of the driver for the storage device customary in a host device.

449 Patent, Claim 1, 11:59-67, 12:1-3 (emphases added); 399 Patent, Claim 1, 12:64-67, 13:1-8 (emphasized portions the same; substitutes the term “input/output device” for “storage device”).

Each of the asserted independent Claims contains similar language, indicating that the data transmit/receive device is attached to the interface device when data is transmitted from the data transmit/receive device to the computer via the interface device. *See* 399 Patent, Claims 1, 11, and 14; 449 Patent, Claims 1, 17, and 18.⁷

Beyond the Claims themselves, the specifications informed the construction that a data transmit/receive device must be capable of transmitting data to a computer when it is attached to the computer via the interface device. With regard to a preferred embodiment of the invention, the specification states:

If the user now wishes to read data from the data transmit/receive device via the line 16, the host device sends a command . . . , whereby [the second command interpreter] begins to transfer data from the data transmit/receive device via the second connecting device to the first connecting device and via the line 11 to the host device.

⁷ Claim One of the 399 Patent claims that the interface device is configured by its processor and memory “to include a first command interpreter and a second command interpreter,” *see* 399 Patent 12:62-63, and “the second command interpreter is configured to interpret a data request command from the host device . . . as a data transfer command *for initiating* a transfer of the digital data to the host device.” 399 Patent, Claim 1, 13:8-12 (emphasis added). This same concept is repeated in other Claims. *See* 399 Patent, Claim 11, 14:17-20 (“the second command interpreter is configured to interpret a data request command from the host device . . . as a data transfer command *for initiating* a transfer of the digital data to the host device”) (emphasis added); *id.*, Claim 14, 14:58-61 (“interpreting a data request command from the host device . . . as a data transfer command *for initiating* a transfer of the digital data to the host device”) (emphasis added). The 449 Patent does not contain similar “for initiating” language.

399 Patent 6:55-67; 449 Patent 5:55-67 (same). As the Court explained in the Claims Construction Opinion, a data transmit/receive device does not transmit data to the interface device until the interface device is connected to the computer:

[D]ata does not begin to be sent from the data transmit/receive device to the interface device until the computer and the interface device have established communication; only then does the second command interpreter begin “to transfer data from the data transmit/receive device via the second connecting device” . . . , then on to “the first connecting device and via the line 11 to the host device.”

Claims Constr. Op. at 44 (quoting 399 Patent 6:64-67 & 449 Patent 5:64-67). The interface device allows *attachment* of a variety of data transmit/receive devices. *See* 399 Patent 1:56-59 (“It is therefore desirable that an interface be sufficiently flexible to permit *attachment* of very different electrical or electronic systems *to a host device* by means of the interface.”) (emphases added); 449 Patent 1:57-60 (same). The terms “attachment” and “line” connote a physical connection. Claims Constr. Op at 37.

Data transfer from a data transmit/receive device to a computer when they are both connected to the interface device is also described in the specification as follows:

Preferably, the interface device according to the present invention simulates a hard disk with a root directory whose entries are “virtual” files which can be created for the most varied functions. *When the host device system with which the interface device according to the present invention is connected is booted and a data transmit/receive device is also attached to the interface device* 10, usual BIOS routines or multi-purpose interface programs issue an instruction, known by those skilled in the art as the INQUIRY instruction, to the input/output interfaces in the host device. The digital signal processor 13 receives this inquiry instruction via the first connecting device and generates a signal which is sent to the host device (not shown) again via the first connecting device 12 and the host line 11. This signal indicates to the host device that, for example, a hard disk drive is attached at the interface to which the INQUIRY instruction was sent. . . .

Regardless of which data transmit/receive device at the output line 16 is attached to the second connecting device, the digital signal processor 13 informs the host device that it is communicating with a hard disk drive.

399 Patent 5:67 & 6:1-22 (emphases added); 449 Patent 4:66-67 & 5:1-22 (same).

Even the title of the invention reflects the basic concept of “connectedness” at the time of data transfer. The invention is titled “Flexible Interface for Communication Between a Host and an Analog I/O Device Connected to the Interface Regardless of the Type of the I/O Device.” *See* 399 Patent, Title; 449 Patent, Title. The title refers to communication between the computer (host) and the data transmit/receive device (I/O device), via the interface device, when the three are “connected.”

Papst filed Final Infringement Contentions asserting that certain accused MSC-capable products are “interface devices” that infringe the Patents. *See* Final Infringement Contentions (FICs) [Dkt. 416], Table 12 (MSC-capable products that allegedly infringe the 399 Patent) & Table 13 (MSC-capable products that allegedly infringe the 449 Patent) (collectively, the “Accused Cameras”).⁸ Papst also alleges that certain external accessories operate as data transmit/receive devices, leading to infringement when utilized with the Accused Cameras. *See generally* FICs at 7-10.⁹ The Final Infringement Contentions identify these “External Accessories” as:

⁸ Papst’s Final Infringement Contentions include two sets of claim charts: a set of charts listing cameras that can communicate with a computer in MSC mode and a set of charts listing cameras that can communicate with a computer in Picture Transfer Protocol (PTP) mode. Some accused products are alleged to operate in both modes. *See, e.g.*, FICs, Table 12 (asserting that Fujifilm model V10 is MSC-capable); *id.*, Table 14 (asserting that Fujifilm model V10 is PTP-capable).

⁹ Papst alleges that data transmit/receive devices that can be readily attached/detached from the “interface portion” of a camera include “image sensors, microphones, auto focus devices, image stabilization devices, internal flash units, infrared ports, touch screens, internal GPS units, and exposure units (including color and/or light metering units).” FICs at 10.

- (1) audio and audio/visual devices (Table 1);
- (2) flashes (Table 2);
- (3) external data devices such as GPS units, bar code scanners, and remote control devices (Table 3);
- (4) lenses (Table 4); and
- (5) printers (Table 6).

Id., Tables 1-4, 6.

The Camera Manufacturers seek summary judgment of noninfringement with regard to the Accused Cameras when they operate in MSC mode according to the following logic: When an Accused Camera is connected to a computer and is operating in MSC mode, none of the External Accessories can transmit data to the computer. Therefore, none of the identified External Accessories meets the “data transmit/receive device” claim limitation when an Accused Camera is in MSC mode. Papst opposes. *See* Opp’n [Dkt. 484] (redacted, public version filed at [Dkt. 481]).¹⁰

¹⁰ Papst’s Final Infringement Contentions fail to allege infringement within the confines of the Court’s claims construction. Instead of expressly alleging that data transmit/receive devices are capable of transmitting data to a computer when a camera is connected to the computer as required by the Claims Construction Opinion, Papst asserts only that data from a data transmit/receive device can be, at some point, transmitted to a computer. Papst alleges that a microphone is a “data transmit/receive device” because it provides data to “the interface portion of an accused device which *in turn*, transmits the data to a host device when connected to the host device.” FICs at 7 (emphasis added). Similarly, Papst alleges that data from various “units” or devices is “ultimately” made available to the host device. *See* FICs at 12, 29 (alleging that autofocus units “communicate information to/from the interface portion of the accused product, and that such information is ultimately made accessible to the host device”); *see also id.* at 13, 31 (identical allegation regarding exposure units such as color and light meters); *id.* at 14, 32 (identical allegation regarding image stabilization devices). That data from a data transmit/receive device may be “in turn” or “ultimately” transmitted to a computer does not claim a data transmit/receive device “capable of . . . transmitting data to [] the host device when connected to the host by the interface device.” *See* Claims Constr. Op. at 31. Papst seeks a modification of the Claims Construction Opinion and does not pretend that its alleged facts are consistent with the Court’s opinion. *See, e.g.,* Opp’n at 2 (“Transmitting data to . . . the host device *when connected* to the host device by the interface device’ is not correctly interpreted to

II. LEGAL STANDARD

Under Rule 56 of the Federal Rules of Civil Procedure, summary judgment shall be granted “if the movant shows that there is no genuine dispute as to any material fact and the movant is entitled to judgment as a matter of law.” Fed. R. Civ. P. 56(a); *accord Anderson v. Liberty Lobby, Inc.*, 477 U.S. 242, 247 (1986). On summary judgment, the burden on a moving party who does not bear the ultimate burden of proof in the case may be satisfied by making an initial showing that there is an absence of evidence to support the nonmoving party’s case. *Celotex Corp. v. Catrett*, 477 U.S. 317, 325 (1986). This burden “may be discharged by ‘showing’—that is, pointing out to the district court—that there is an absence of evidence to support the nonmoving party’s case.” *Id.*

The burden then shifts to the nonmovant to demonstrate the existence of a genuine issue of material fact. The nonmovant may not rest on mere allegations or denials, but must instead by affidavit or otherwise, present specific facts showing that there is a genuine issue for trial. *See* Fed. R. Civ. P. 56(c); *Celotex*, 477 U.S. at 324; *see also Greene v. Dalton*, 164 F.3d 671, 675 (D.C. Cir. 1999) (nonmovant must present specific facts that would enable a reasonable jury to find in its favor).

In ruling on a motion for summary judgment, the court must draw all justifiable inferences in the nonmoving party’s favor. *Anderson*, 477 U.S. at 255. A nonmoving party, however, must establish more than “the mere existence of a scintilla of evidence” in support of its position. *Id.* at 252. In addition, if the evidence “is merely colorable, or is not significantly

require that the interface device act as a ‘conduit’ for live data or the like, but instead that the interface device acquires data from a [data transmit/receive device] and lets a host computer read the data while the host computer is connected to the interface device, regardless of whether the [data transmit/receive device] is connected to the interface device.”). As discussed below, Papst’s request for reconsideration will be denied.

probative, summary judgment may be granted.” *Anderson*, 477 U.S. at 249-50 (citations omitted). Summary judgment is properly granted against a party who “after adequate time for discovery and upon motion . . . fails to make a showing sufficient to establish the existence of an element essential to that party’s case, and on which that party will bear the burden of proof at trial.” *Celotex*, 477 U.S. at 322.

Summary judgment can be granted in a patent case if there is no dispute over the structure of the accused products, at which point the question of infringement “collapses” into the question of claim construction and may be resolved by the court. *Desper Prods. Inc. v. QSound Labs Inc.*, 157 F.3d 1325, 1332-33 (Fed. Cir. 1998). The burden of proving infringement rests on the patent holder. *Welker Bearing Co. v. PHD, Inc.*, 550 F.3d 1090, 1095 (Fed. Cir. 2008). Thus, on summary judgment the Camera Manufacturers bear the burden of making an initial showing that there is an absence of evidence to support Papst’s claim of infringement, and Papst bears the burden of presenting specific facts showing that there is a genuine issue for trial.

III. ANALYSIS

A. Literal Infringement

To prove literal infringement, a patentee must prove that the accused product satisfies each and every limitation of a claim. *Warner-Jenkinson Co. v. Hilton-Davis Chem. Co.*, 520 U.S. 17, 29 (1997); *Rohm & Haas v. Brotech Corp.*, 127 F.3d 1089, 1092 (Fed. Cir. 1997). The party alleging infringement bears the burden of proof. *Jazz Photo Corp. v. Int’l Trade Comm’n*, 264 F.3d 1094, 1102 (Fed. Cir. 2001). To determine whether a patent has been infringed, a court must (1) construe the patent and (2) compare the devices accused of infringing to the construed patent claims. *Mars, Inc. v. H.J. Heinz Co., LP*, 377 F.3d 1369, 1373 (Fed. Cir.

2004). Since this Court already has interpreted the Patents, the Court now proceeds to step two, a comparison of the Accused Cameras to the allegedly infringed Claims.

A patent is literally infringed “when each of the claim limitations reads on, or in other words is found in, the accused device.” *Allen Eng’g Corp. v. Bartell Indus., Inc.*, 299 F.3d 1336, 1345 (Fed. Cir. 2002). If a device does not infringe an independent claim of a patent, the device cannot infringe a claim dependent on that claim.¹¹ *Wahpeton Canvas Co., Inc. v. Frontier, Inc.*, 870 F.2d 1546, 1552 n.9 (Fed. Cir. 1989).

1. Absence of Evidence to Support Papst’s Infringement Allegation

An interface device can satisfy Claim One of the Patents only if it is capable of transmitting data from a data transmit/receive device to a computer when all three are connected. The Camera Manufacturers insist that when an Accused Camera is connected to a computer in MSC mode, it *cannot* transmit data from one of the identified External Accessories. Instead, when in MSC mode, the computer controls the camera memory that it can access and receives data only from the camera itself, not from an External Accessory. In this configuration, no data is or can be transmitted from any of the identified External Accessories to the computer. Therefore, the Camera Manufacturers conclude, when any Accused Camera is connected to a computer and operating in MSC mode, the External Accessories cannot not meet the “data transmit/receive device” claim limitation.

The Camera Manufacturers note that an ordinary user can observe the fact that an External Accessory does not transfer data to a computer when attached to a camera operating in MSC mode. A user can attach an External Accessory to an Accused Camera that is connected

¹¹ A claim in “dependent form” incorporates by reference all the limitations of the claim on which it depends and adds something new, giving it a narrower scope than the claim from which it depends. *See* 35 U.S.C. § 112; *Phillips*, 415 F.3d at 1315.

to a computer and operating in MSC mode. Using a Windows-based computer, the user can click on the “My Computer” icon. A camera connected to a computer in MSC mode will appear in the “My Computer” directory as a “Removable Disk.” The user can see that the files in the “Removable Disk” directory do not change if and/or when External Accessories are attached to the camera. Papst presents various objections (and attempts to obfuscate) but never actually contests these assertions by the Camera Manufacturers. The Court thus takes notice of the readily observable operation of an Accused Camera operating in MSC mode.

To further describe the contours of camera operation while in MSC mode, the Camera Manufacturers present a declaration by Paul Berg. Mr. Berg is an expert in Universal Serial Bus (USB) and MSC communications. Mot. for Summ. J. Re Data Transmit/Receive Device Limitation [Dkt. 451], Ex. C (Berg Decl.) [Dkt. 451-3] ¶¶ 4-11. He was one of the authors of the original USB 1.0 Specification, published in 1996. *Id.* ¶¶ 5, 7. Since that time, USB technology has become his primary focus; he has been a speaker and seminar leader at numerous meetings of USB implementers; he was a reviewer and contributor for the USB 1.1, 2.0, and 3.0 Specifications. *Id.* ¶¶ 7, 8.¹²

USB is a “connection standard” for communication between a computer and peripherals such as keyboards, mice, and printers. *Id.* ¶ 13. Devices that can connect to a computer using a USB interface can be categorized into different classes, one of which is USB Mass Storage Class. USB MSC devices include “memory sticks and external hard drives that

¹² Papst challenges Mr. Berg’s qualifications as an expert, complaining that he is “not an expert in digital systems in general.” *See* Opp’n at 2, 10-17. Papst does not explain what it means by “digital systems in general” or why such expertise would be required to evaluate when, and under what circumstances, External Accessories can transfer data through an Accused Camera, operating in MSC mode, to a computer. This objection to Mr. Berg’s qualifications is too amorphous to raise an issue.

can be plugged into the USB port of a computer. Additionally, other devices, such as digital cameras, may operate as a USB MSC device when connected to a computer.” *Id.* ¶ 14.

Mr. Berg describes generally the operation of an MSC device when it is connected to a computer as follows:

15. The data transfer between a USB MSC device and a computer is governed by the USB Mass Storage Class Specifications and other standards, such as the Small Computer System Interface (“SCSI”) Standards. These standards define the specific commands and specific responses communicated between a computer and a USB MSC device. The way in which those commands and responses are transported back and forth across the USB connection for a USB MSC device is defined in and governed by USB MSC Specifications.

16. When a USB MSC device is connected to a computer by the USB interface, the connection is a “hosted” connection. The host (computer) is in charge of the connection, and controls and initiates all transmissions that pass through the USB interface. No connected USB MSC device can transfer any data through the USB interface without an explicit request from the host. In other words, the connected USB MSC device does only what it is told to do by the host.

17. When a USB MSC device is connected to a computer, the computer has control over the USB MSC device’s memory that it can access (the “MSC Memory”). The USB MSC Specifications and standard MSC drivers do not support the change of data on a connected USB MSC device by anything other than the host computer. These specifications and drivers were based on USB MSC devices, such as external hard drives, which have no ability to change their stored data, other than by the host computer to which it is connected.

18. To allow for proper operation, USB MSC devices cannot allow any of their data to change, other than by the connected computer. Errors and/or data loss may occur if the data on a USB MSC device were to change other than as directed by the host computer to which it is connected.

19. When connected to a computer, the MSC memory of the USB MSC devices, operating pursuant to the USB MSC Specifications and standard MSC drivers, does not store any data from any source

other than from the computer to which it is connected. The only data that is capable of being transmitted from the USB MSC device to the computer is the data that already existed on the USB MSC device prior to the time the device was connected to the computer or data from the computer that may be subsequently transferred to the USB MSC device.

20. Similarly, *no data can be transmitted from accessories*, such as audio sources, audio/video sources, flashes, GPS units, remote control unites, lenses and printers, *that are attached to a USB MSC device*, such as a camera or camcorder, *to a connected computer* via the USB MSC interface.

Berg Decl. ¶¶ 15-20 (emphases added). Most importantly, Mr. Berg explains that no data can be transmitted to a computer via the USB MSC interface from External Accessories when such External Accessories are attached to an Accused Camera operating in MSC mode. *Id.* ¶ 20.

Mr. Berg also tested the MSC-mode operation of various Accused Cameras and External Accessories. He used a bus analyzer that monitors communications on the USB connection between a computer and an attached device, and he reports that no data was transmitted from any External Accessory to the computer when connected to an Accused Camera which was connected to a computer and which was operating in MSC mode. Berg Decl. ¶¶ 49, 51-53.

Thus, the Camera Manufacturers have made an initial showing in support of summary judgment—they have pointed to the absence of evidence supporting Papst’s claim that the External Accessories meet the Patents’ data transmit/receive device limitation when used with Accused Cameras operating in MSC mode. *See Celotex*, 477 U.S. at 325 (the burden on a moving party who does not bear the burden of proof may be discharged by pointing out that there is an absence of evidence to support the nonmoving party’s case.) The burden thus shifts to Papst to support its claim that the External Accessories are data transmit/receive devices as the Court construed the term, i.e., devices capable of transmitting data to the host device when

connected to the host by the interface device. *See* Claims Constr. Op. at 31. Papst bears the burden of presenting some evidence that the External Accessories are capable of transmitting data to a computer when connected to the computer by an Accused Camera operating in MSC mode. *See id.* at 322 (summary judgment can be granted against a party who fails to make a showing sufficient to establish an element essential to the party's case, on which he bears the burden of proof). Papst has failed to do so.

2. Papst's Attempt to Create an Issue of Fact

In opposing summary judgment, Papst does not challenge the Camera Manufacturers' assertion that the functionality of the Accused Cameras and the External Accessories can be readily observed. As far as the record reveals, Papst failed to make its own observations or conduct any tests. Instead, Papst presents an opposing expert declaration from Dr. C. Douglass Locke, who challenges Mr. Berg and attempts to raise genuine issues of material fact for jury determination. *See* Papst's Notice of Filing Documents [Dkt. 475], Third Locke Decl. [Dkt. 475-2] ¶¶ 509-559.¹³ Dr. Locke's Declaration does not reveal any genuine issues of material fact that preclude summary judgment on this motion. Dr. Locke has shown himself to be more dedicated to his client than to his science. Almost every paragraph of his Third Declaration, as it relates to the critical issues here, contains a statement that is irrelevant, contradictory, supportive of Mr. Berg's declaration, or plainly dissembling. Because it is necessary to understand why Dr. Locke's Third Declaration carries no weight, the Court elaborates:

¹³ Dr. Locke's Third Declaration addresses numerous motions; paragraphs 509-559 are relevant here.

1. Third Locke Decl. ¶ 513: Dr. Locke disagrees with Mr. Berg’s characterization of the SCSI Standards. The asserted disagreement is irrelevant and does not create a genuine dispute.
2. Third Locke Decl. ¶ 514: Dr. Locke complains that Mr. Berg uses “data” transfer to mean one thing in ¶ 15 of the Berg Declaration, and “appears” to apply a different meaning for “data” transfer elsewhere. This objection is too vague, imprecise, and uncertain to convey any meaning. In addition, Dr. Locke’s admission that he in fact understands the USB Mass Storage Class communication protocol, to which ¶ 15 of the Berg Declaration refers, reveals the insincerity of the objection. *See* Third Locke Decl. ¶ 505 (Dr. Locke notes that “USB MSC devices communicate with computers as if they were hard disk drives using SCSI command sets . . .”).
3. Third Locke Decl. ¶¶ 516 & 517: Dr. Locke asserts that flash memory chips inserted into USB MSC devices “would perform the address translation function” without command by the host computer so that Mr. Berg’s statement (¶ 16), “the connected USB MSC device does only what it is told to do by the host,” is wrong. Whether flash memory chips might perform any function when an Accused Camera in MSC mode is connected to a computer is irrelevant. Flash memory chips are not the subject the Camera Manufacturers’ instant motion. Most critically, Dr. Locke does not challenge the preceding sentence of Mr. Berg’s declaration. Mr. Berg declared, “No connected USB MSC device can transfer any data through the USB interface without an explicit request from the host.”

Berg Decl. ¶ 16.¹⁴ Dr. Locke asserts that flash memory chips can perform address translation, not that they can transfer data through a digital camera to the computer while the camera is connected to the computer in MSC Mode.

4. Third Locke Decl. ¶ 518: Dr. Locke asserts that a USB MSC with an Eye-Fi memory card can act on its own without control by the computer: “While connected, the Eye-Fi card continued to add new data and modify data previously stored in the memory of the card about certain card operations while the card was installed in the camera in the mass storage mode . . . even though the host computer did not tell the camera to store such information.” Again, whatever the accuracy of Dr. Locke’s statement concerning Eye-Fi cards, it is not relevant as Eye-Fi cards are not External Accessories and thus are not the subject of the Camera Manufacturers’ motion for summary judgment. Further, that an Eye-Fi memory card might modify data in its *own* memory does nothing to contradict the evidence that an External Accessory cannot transmit data to the computer through an Accused Camera when the camera is in MSC mode.
5. Third Locke Decl. ¶ 519: With regard to Mr. Berg’s statement in his Declaration ¶ 16 that “the host (computer) is in charge of the connection, and controls and initiates all transmissions that pass through the USB interface,” Dr. Locke complains that it is not clear what Mr. Berg meant by the statement the computer is “in charge of the connection.” While Dr. Locke claims to find Mr. Berg’s

¹⁴ The specifications for the Patents reflect the concept that data is transferred from the data transmit/receive device when commanded to do so by the computer. *See* 399 Patent 6:55-67 (“If the user now wishes to read data from the data transmit/receive device via the line 16, the host device sends a command . . . , whereby [the second command interpreter] begins to transfer data from the data transmit/receive device via the second connecting device to the first connecting device and via the line 11 to the host device.”); 449 Patent 5:55-67 (same).

Declaration unclear, the Court does not. The statement that the computer is “in charge of the connection” means that the computer “controls and initiates all transmissions that pass through the USB interface,” as described by Mr. Berg in the very same sentence.

6. Third Locke Decl. ¶ 520: Dr. Locke contends that “it is not clear what Mr. Berg defines as ‘MSC memory.’” Mr. Berg’s Declaration is unambiguous. He expressly defined the allegedly vague term, saying, “[w]hen a USB MSC device is connected to a computer, the computer has control over the USB MSC device’s memory that it can access (the ‘MSC Memory’). The USB MSC Specifications and standard MSC drivers do not support the change of data on a connected USB MSC device by anything other than the host computer.” Berg Decl. ¶ 17.
7. Third Locke Decl. ¶ 521: Dr. Locke claims to be unclear as to the meaning of “standard MSC drivers.” Dr. Locke’s opinion on the alleged lack of clarity is irrelevant to the issues at hand.
8. Third Locke Decl. ¶ 522: Dr. Locke attacks Mr. Berg’s statement that “USB MSC Specifications and standard MSC drivers do not support the change of data on a connected USB MSC device by anything other than the host computer,” Berg ¶ 17, because “data can be changed on a USB MSC device independent of an attached host device,” for which he references Eye-Fi memory cards. Again, the point is irrelevant. The Camera Manufacturers do not seek summary judgment on whether memory cards and/or Eye-Fi cards are data transmit/receive devices.
9. Third Locke Decl. ¶ 523: Dr. Locke challenges Mr. Berg’s statement that USB MSC Specifications and standard MSC drivers “were based on USB MSC

devices, such as hard drives, which have no ability to change their stored data.”

Berg Decl. ¶ 17. Dr. Locke complains that Mr. Berg provides no documentary support and “even if a typical hard drive may not be able to change its data independently of the host computer, other kinds of USB MSC devices can change their data independently of the host computer.” Again, he references only Eye-Fi memory cards, and again, Eye-Fi memory cards are not External Accessories and are not relevant to the Camera Manufacturers’ motion.

10. Third Locke Decl. ¶ 524: Dr. Locke continues the same charade. He addresses Berg Declaration ¶ 18, which declares, “USB MSC devices cannot allow any of their data to change, other than by the connected computer” Dr. Locke asserts that Eye-Fi cards can change their internal data, and that any loss of data can be “ameliorated.” Third Locke Decl. ¶ 524. Although this paragraph *appears* to dispute Mr. Berg’s Declaration, upon examination, it clearly does not. Eye-Fi cards are not at issue here, nor is their ability to ameliorate data loss.

11. Third Locke Decl. ¶ 526: Dr. Locke declares, “as discussed above, there are no ‘standard MSC drivers.’” To be precise, what was “discussed above” was Dr. Locke’s professed need for a definition from Mr. Berg as to what are “standard MSC drivers,” *not* that there are no such things. Dr. Locke notes that an Accused Camera will continue to store any data it contained before connection to a computer, which can “include data from sources other than the host computer, such as data from accessories” *Id.* He finishes this sentence by adding, “[such as data from accessories] connected to a digital camera that operates in MSC mode,” without specifying that such data must have been received by the

camera and stored in the camera's memory before it was connected to the computer in MSC mode. Thus, his sentence starts out with an accurate statement and bends it into an untrue statement. His attempt to mislead is not overlooked.

12. Third Locke Decl. ¶ 527: Dr. Locke purports to disagree with Berg Declaration ¶ 19 that “[t]he only data that is capable of being transmitted from the USB MSC device to the computer is the data that already existed on the USB MSC device prior to the time the device was connected to the computer or data from the computer that may be subsequently transmitted to the USB MSC device.” Dr. Locke declares that “[t]his is incorrect . . . Eye-Fi cards can generate and store new data even when the device to which the cards is installed is connected to a host computer in mass storage mode.” Third Locke Decl. ¶ 527. Again, Eye-Fi cards are irrelevant to the Camera Manufacturers' motion for summary judgment.

13. Third Locke Decl. ¶ 529: Dr. Locke opines broadly that “new data can be generated by accessories attached to a camera even when the camera is attached to a computer” and that “[t]his new data can be transferred to the computer, as explained in paragraph 518 of this declaration.” Paragraph 518 describes the operation of an Eye-Fi memory card. *See id.* ¶ 518 (“While connected, the Eye-Fi card continued to add new data and modify data previously stored in the memory in the card about certain card operations while the card was installed in the camera in mass storage mode.”). Again, Eye-Fi memory cards are not included among the External Accessories discussed here and are not the subject of the instant motion. Thus, the operation of Eye-Fi memory cards is irrelevant to the matter at hand, even if one read ¶ 518 to mean more than it says — i.e., that

Eye-Fi memory cards can add or change data in their memories when attached to a camera in MSC mode that is, in turn, attached to a computer. This alleged “fact” does not convey a data flow from an Eye-Fi card through a camera to a computer nor does it otherwise contradict Mr. Berg.

14. Third Locke Decl. ¶¶ 532-537: Dr. Locke describes Mr. Berg’s bus trace evidence regarding a Nikon D200 camera. The Nikon D200 camera transmitted the beginning part of a digital photographic file, *id.* ¶ 535, which included information regarding accessories, such as information from the lens, flash, and GPS. *Id.* ¶ 536. According to Dr. Locke, this proves that “at least information from a lens attached to the Nikon D200 camera was transferred to the host computer.” *Id.* ¶ 537. This statement can only have been intended to confuse and dissemble. Dr. Locke’s Declaration itself notes that this phenomenon occurred *before* the camera was connected to the computer:

[T]he Nikon D200 does not have a built in lens, but to operate as intended, requires a lens to be attached to take a picture. . . . Mr. Berg’s test results show that data from the attached lens, including data representative of at least the focal length of the attached lens, was communicated from the attached lens to the camera *when he took a picture with the Nikon D200 camera. This data was then stored in a picture file and later transferred to [the] host computer during Mr. Berg’s test.*

Id. ¶ 555 (emphasis added). In other words, the photo, with lens data, was in the camera’s memory *before* the camera was connected to the computer; the camera stored the data and later transferred it to the computer; the lens data was *not* transferred separately from the lens to the computer.

15. Third Locke Decl. ¶ 541 complains that cameras “operate in various modes, including, for example, modes for diagnostics, testing, and repair. Mr. Berg does

not identify any of the various modes of operation in the CMs Accused Products, nor does he state that he tested the products in each of these modes.” In Dr. Locke’s opinion, this made Mr. Berg’s tests “deficient.” *Id.* The problem with Dr. Locke’s complaint is that Papst only alleged infringement in MSC and PTP modes and not in any other mode. The only mode relevant to the current motion is the MSC mode. Mr. Berg’s tests were not deficient in the least. Also, Papst never alleged infringement by way of any “back door” mode for diagnostics, testing and repair. The Camera Manufacturers do not bear the burden of proof, much less the burden as to a never-alleged infringement method.

16. Third Locke Decl. ¶ 542: Dr. Locke asserts that, in his view, Mr. Berg should have talked to employees of the Camera Manufacturers about other modes. Dr. Locke’s “view” notwithstanding, Papst alleged infringement by use in MSC or PTP modes only.

17. Third Locke Decl. ¶ 554: Finally, Dr. Locke complains that Mr. Berg “does not explain what he means by ‘MSC mode,’ why he used the ‘MSC mode,’ or whether the products operate in any other modes when the products would communicate with a connected computer using the USB Mass Storage Class communication protocol.” Dr. Locke’s assertion that he does not understand what Mr. Berg means when he refers to testing a camera operating in “MSC mode” is disingenuous. Dr. Locke is no neophyte. *See* Papst’s Notice of Filing Documents [Dkt. 475], Curriculum Vitae for Dr. Locke [475-3].¹⁵ He fully knows and

¹⁵ Dr. Locke obtained a Ph.D. in computer science from Carnegie Mellon in 1986. Curriculum Vitae for Dr. Locke at 4. He has worked as a consultant (1981 to the present), as an instructor for the Air Force (1992-1995), and as a scientist at Lockheed Martin (1996-2000). *Id.* at 2-3.

understands the USB Mass Storage Class communication protocol, as he notes in his Declaration that “USB MSC devices communicate with computers as if they were hard disk drives using SCSI command sets” Third Locke Decl. ¶ 505. Obviously, Mr. Berg focused on MSC mode, as that was the subject of the Camera Manufacturers’ investigation for the purpose of this motion. Dr. Locke’s pretense (that Mr. Berg’s statements are unclear) is an attempt to obfuscate the issues.

In sum, Dr. Locke’s challenge to the Berg Declaration on MSC USB devices and the operation of the Accused Cameras is full of irrelevancies, hidden agreements with Mr. Berg, and acknowledgement that he fully understands what he contended was unclear. The Third Locke Declaration does not present any genuine dispute on any material fact. It offers nothing to the disposition of the motion for summary judgment.

While Papst disagrees with Mr. Berg’s conclusion that External Accessories cannot transmit data to a computer when attached to an Accused Camera operating in MSC mode, Papst fails to raise any genuine issue of material fact. The *only* allegedly contrary evidence that Papst provides is the bus trace of lens data and the Nikon D200. But Dr. Locke expressly concedes this evidence shows only that the lens transferred data to the camera *before* the camera was connected to the computer. *See* Third Locke Decl. ¶ 555.

Dr. Locke has an “extensive background in areas such as software performance, real-time architecture, design, implementation, and deployment, standards, software engineering maturity, and software organization.” *Id.* at 1. He has written numerous articles, mostly regarding real-time systems. *Id.* at 4-6. Further, “[w]hile he has concentrated more on software and systems design and implementation, his understanding of hardware, including communication protocols, interface mechanisms, and control mechanisms has proven to be critical to the success of many major systems.” *Id.*

3. New Theory of Infringement

Papst attempts to ward off summary judgment in various other ways, to no avail. Papst asserts a new theory of infringement, arguing that some of the Accused Cameras have a “back door” mode of operation that is used for diagnostics, testing, and repair and that when operated in this mode, the Accused Cameras can take pictures and operate accessories while connected to a computer. *See* Opp’n at 8-9. Papst also seeks more discovery regarding the “back door” mode of operation. *Id.* at 9; *see also* Mot. for 56(d) Disc. [Dkt. 479] at 17-19. Papst failed, however, to allege infringement based on this “back door” theory in its Final Infringement Contentions. It is too late to do so now. The Court ordered Papst to file final infringement contentions in compliance with detailed requirements. *See* Mot. for Sanctions [Dkt. 388], Ex. A (Tr. of Aug. 31, 2010 Hearing); Sixth Prac. & Pro. Order (Sixth PPO) [Dkt. 372]. Because Papst filed Final Infringement Contentions that failed to comply with Court’s orders, the Court barred Papst from advancing any arguments for infringement (or against claims of noninfringement) that either (1) are not based solely on this Court’s constructions of the Patents or (2) are not already set forth specifically and explicitly in Papst’s Final Infringement Contentions. *See* Sanctions Op. [Dkt. 429] at 13; Sanctions Order [Dkt. 430] at 2. Accordingly, Papst is barred from asserting this new theory of infringement.

4. “Real Time” Data Transmission

Additionally, Papst mischaracterizes the Camera Manufacturers’ motion as interpreting the Patents to require simultaneous physical connection and communication of live “real time” data (i.e., data streaming). *See* Opp’n at 19 (Papst asserts that the Camera Manufacturers’ argument is “built on the questionable premise that the accused products never transmit live data from external accessories to an attached host computer . . . , that delayed data

transmissions are noninfringing, and that only real-time, ‘active’ transmissions would be infringing.”). Papst blatantly errs in so advertising the Camera Manufacturers’ motion. The Claims and the specifications do not require that all transfers of data from a data transmit/receive device be “real time” transfers, and the Camera Manufacturers do not contend that they do.¹⁶

Papst explains that the Patents cannot possibly require live data streaming, because to construe them this way would nullify Claims concerning “virtual files.”¹⁷ The Court construed the term “virtual files” to mean “files that appear to be but are not physically stored; rather, they are constructed or derived from existing data when their contents are requested by an application program so that they appear to exist as files from the point of view of the host device.” Claims Constr. Op. at 67. Because virtual files are derived from “existing data,” Papst reasons that they are not derived from live incoming data. Opp’n at 21.¹⁸ Papst’s warning that agreement with the Camera Manufacturers would invalidate claims dealing with “virtual files” is

¹⁶ Papst protests that “[n]o claim language requires the ‘second connecting device’ to be actively receiving live data from a [data transmit/receive device] *at the same time* that data is being provided to the host via the ‘first connecting device.’” Opp’n at 3. The Court did not adopt “real time” data transmission as a Claim limitation. The Patents refer to “real time” data transfer only as a preferred embodiment. *See* 399 Patent 9:24-27 (in the preferred embodiment of the invention, “the digital signal processor implements a fast Fourier transformation (FFT) in real time and also optional data compression of the data to be transferred from the data transmit/receive device to the host device”); 449 Patent 8:24-27 (same). While this point is accurate, it is not argued by the Camera Manufacturers.

¹⁷ Papst refers particularly to dependent Claim 7, which claims an interface device according to Claim 2 and “which further comprises a root directory and *virtual files* which are present on the signaled hard disk drive and which can be accessed from the host device.” 399 Patent 13:33-36 (emphasis added).

¹⁸ “Existing data” may reside in the interface device. *See* 399 Patent, Claim 8, 13:38-39 (“virtual files comprise a configuration file in text format which are stored in the memory means” of the interface device); *id.*, Claim 9, 13:43-47 (virtual files may “comprise batch files or executable files for the microprocessor means which are stored on the interface device to perform data processing, independently of the host device, of data received via the second connecting device”).

based wholly on the incorrect assertion that the Camera Manufacturers interpret the Patents as requiring “real time” data streaming. The Camera Manufacturers do not assert that the Patents require “real time” data transmission; their motion is based on the Court’s definition of “data transmit/receive device” and the fact that External Accessories do not meet the definition because they cannot transmit data to a computer when they are attached to the Accused Cameras operating in MSC mode. This is the case regardless of the timing of data transmission.

5. Papst’s Request for Reconsideration

Papst also opposes summary judgment by asking the Court to reconsider its construction of the “data transmit/receive device” claim limitation. This is Papst’s third motion to obtain reconsideration of claims construction. In its first motion, Papst sought reconsideration of the “data transmit/receive device” claim limitation, arguing that a data transmit receive/device could engage in one-way or in two-way communication, that is, it could send data to the interface device or it could send data to and receive data from the interface device. Mot. Recons. [Dkt. 321]. The Court granted that motion. *See* Claims Constr. Op. at 2, 27-31 (modifying prior Op. [Dkt. 312]). Papst’s second motion for reconsideration sought reconsideration of other claim limitations.¹⁹ *See* Mot. Recons. [Dkt. 339]. It was denied. *See* Order [Dkt. 343] (finding that Papst did not present a valid basis for reconsideration and that Papst’s piecemeal approach to litigation was not justified).

Papst now asks the Court to reconsider its determination that a “data transmit/receive device” is a device capable of data transmission when connected to a computer by the invented interface device. *See* Claims Const. Op. at 31. Papst presents two arguments.

¹⁹ Less formal efforts to achieve reconsideration of various Patent terms construed by the Court have peppered Papst’s filings.

First, Papst contends that the “data transmit/receive device” is not a claim limitation at all and should not be treated as limiting the scope of the Patents. Papst made this argument already, and the Court addressed it as follows:

Mr. Tasler did not invent a data transmit/receive device, and Papst objects to any construction of the term. Tr. 1:136 (Papst) (“So our first position, of course, is that we shouldn’t be defining this as part of the claimed invention.”). While Papst asserts that the term “data transmit/receive device” is not a claim limitation, Papst concedes that the term may be construed “for context” as “a device that receives input and provides data to the interface device.” Papst’s App. at 2. The Court agrees that it should not define the nature of a data transmit/receive device. What is at issue, however, is the communication capability between the invented interface device and a data transmit/receive device, which is very much part of construing the Claims, and the Court construes “data transmit/receive device” in this context.

Claims Constr. Op. at 27. Papst reads this portion of the Claims Construction Opinion too broadly. While the Court agreed that Mr. Tasler did not invent a data transmit/receive device and agreed that the precise nature of the data transmit/receive device should not be defined, the Court determined that it was necessary to define the “communication capability” of the data transmit/receive device. *Id.* The Court proceeded to define the term, in accordance with its “communication capability,” as “a device that is capable of either (a) transmitting data to or (b) transmitting data to and receiving data from the host device when connected to the host device by the interface device.” *Id.* at 27, 31. In addition, the Court held that the preamble, which describes the invention as “an interface device for communication between a host device . . . and a data transmit/receive device,” 399 Patent 12:42-46 & 449 Patent 11:45-49, operated as a claims limitation. *See* Claims Constr. Op. at 18-23. Thus, the data transmit/receive device, per the definition provided by the Court, is in fact a claims limitation.

Second, Papst argues that the Court should redefine “data transmit/receive device” to mean “a device that is capable of either (a) transmitting data to or (b) transmitting data

to and receiving data from the host device *regardless of whether it is connected* to the host device by the interface device.” Papst argues that the word “connected” does not mean “attached” or physically connected. Instead, Papst argues that the word should be accorded a looser meaning and that “connected” should be interpreted to mean joined by communication, as people are “connected” when they communicate by letter or email. *See* Opp’n at 19-21.

The Court declines the invitation to construe yet again the term “data transmit/receive device.” The Court already ruled, and Papst fails to meet the standard for reconsideration. *Singh v. George Wash. Univ.*, 383 F. Supp. 2d 99, 101 (D.D.C. 2005) (reconsideration may be permitted when a court has patently misunderstood a party, has made a decision outside the adversarial issues presented to the court by the parties, has made an error not of reasoning but of apprehension, or where a controlling or significant change in the law or facts has occurred since the submission of the issue to the court.) There has been no controlling or significant change in the law or the facts, and Papst fails to show that the Court patently misunderstood a party, made a decision outside the adversarial issues presented, or made an error of apprehension. As described in detail above, the Court’s definition of “data transmit/receive device” is well-grounded in the language of the Patents:

(1) Data does not begin to be sent from the data transmit/receive device to the interface device until the computer and the interface device have established communication. Claims Constr. Op. at 44; *see also* 399 Patent 6:64-67 & 449 Patent 5:64-67.

(2) The specification describes communication between a computer and a data transmit receive device when they are *both* connected to the interface device. *See* 399 Patent 5:67 & 6:1-15 (communication begins “[w]hen the host device system with which the interface device according to the present invention is connected is booted and a data transmit/receive device is also attached to the interface device.”); 449 Patent 5:2-6 (same).

(3) The title of the Patents, “Flexible Interface for Communication Between a Host and an Analog I/O Device Connected to the

Interface Regardless of the Type of the I/O Device,” describes the invention as a device for communication between the computer and a data transmit/receive device when the three are “connected.” See 399 Patent, Title; 449 Patent, Title.

The Court will deny Papst’s request for reconsideration.

Because the External Accessories cannot transmit data to a computer when connected to a computer by an Accused Camera operating in MSC mode, the External Accessories do not meet the “data transmit/receive device” claim limitation. Because Papst has failed to demonstrate any genuine issue of material fact regarding this motion, the motion for summary judgment of noninfringement will be granted in favor of the Camera Manufacturers.

B. Doctrine of Equivalents

Papst also objects to summary judgment, asserting that the Accused Cameras infringe under the doctrine of equivalents. This doctrine is inapplicable here. The essential inquiry in a determination under the doctrine of equivalents is whether “the accused product or process contains elements identical or equivalent to each claimed element of the patented invention.” *Am. Calcar, Inc. v. Am. Honda Motor Co.*, 651 F.3d 1318, 1338 (Fed. Cir. 2011) (quoting *Warner-Jenkinson*, 520 U.S. at 40). An element in an accused product is deemed to be equivalent to a claim limitation if the difference between the two is “insubstantial” to a person of ordinary skill in the art. *Wavetronix v. EIS Elec. Integrated Sys.*, 573 F.3d 1343, 1360 (Fed. Cir. 2009). In order to assess insubstantiality, a court considers whether an element of the accused product “performs substantially the same function in substantially the same way to obtain the same result” as the patented invention. *Am. Calcar*, 651 F.3d at 1338. This is often referred to as the “function/way/result test.” *Id.* A patentee alleging infringement under the doctrine of equivalents must submit particularized evidence of equivalence and must explain specifically

why the difference between what the claims literally require and what the accused products actually do is “insubstantial.” *Id.*

The Final Infringement Contentions fail to assert specific claims that the External Accessories meet the “data transmit/receive device” claim limitation under the doctrine of equivalence with the precision that the Court required. *See* Mot. for Sanctions, Ex. A (Tr. of Aug. 31, 2010 Hearing); Sixth Prac. & Pro. Order (Sixth PPO). Papst is barred from now making a more explicit claim. *See* Sanctions Op. at 13 (as a sanction for its misconduct, Papst may not advance any claim for infringement not already set forth specifically and explicitly in the FICs); Sanctions Order at 2 (same).

C. Papst’s Request for Additional Discovery

Papst filed a motion for Rule 56(d) discovery, claiming that it needs further fact discovery to oppose summary judgment. *See* Mot. for 56(d) Disc. [Dkt. 479]; Reply [Dkt. 515]. Federal Rule of Civil Procedure 56(d) provides:

If a nonmovant shows by affidavit or declaration that, for specified reasons, it cannot present facts essential to justify its opposition, the court may:

- (1) defer considering the motion or deny it;
- (2) allow time to obtain affidavits or declarations or to take discovery; or
- (3) issue any other appropriate order.

Fed. R. Civ. P. 56(d). “The nonmoving party bears the burden of identifying the facts to be discovered that would create a triable issue and the reasons why the party cannot produce those facts in opposition to the motion. The nonmoving party must show a reasonable basis to suggest that discovery would reveal triable issues of fact.” *Scott-Blanton v. Universal City Studios Prods. LLP*, 246 F.R.D. 344, 347 (D.D.C. 2007), *aff’d* 308 F. App’x 452 (D.C. Cir. 2009). A

generalized, speculative request for more discovery is insufficient; a request for more discovery must show that “further *specific* discovery will defeat a summary judgment motion.” *Estate of Parsons v. Palestinian Auth.*, 715 F. Supp. 2d 27, 35 (D.D.C. 2010), *aff’d*, No. 10-7085, 2011 WL 3528749 (D.C. Cir. Aug. 12, 2011).

Papst seeks information regarding “real time” operation and “back door” connection. *See generally* Mot. for Rule 56(d) Disc. at 15-19; Reply at 3-6. Further, Papst wants to depose Mr. Berg regarding “various secret back door modes of operation.” Reply at 5. Papst fails to show, however, how such discovery would reveal triable issues of fact. As explained above, the Camera Manufacturers do not contend that the Court’s construction of the “data transmit/receive device” claim limitation requires “real time” communication. Also, Papst’s Final Infringement Contentions do not include any allegations of infringement by devices operating in a “back door” mode. “Real time” operation and “back door” connection are not at issue here.

Accordingly, the Camera Manufacturers have met their burden on summary judgment (1) by pointing to the readily observable fact that External Accessories cannot transfer data to a computer when attached to an Accused Camera operating in MSC mode and (2) by submitting Mr. Berg’s Declaration. As the party opposing summary judgment, Papst then bore the burden of demonstrating a genuine issue of material fact requiring trial. It failed to do so with Dr. Locke’s Declaration or in any other way.

IV. CONCLUSION

The Camera Manufacturers’ motion for summary judgment of noninfringement with respect to the “data transmit/receive device” claim limitation [Dkt. 451] will be granted.²⁰

²⁰ Papst moved to file a surreply in opposition to the Camera Manufacturers’ motion for summary judgment with respect to the “data transmit/receive device” limitation. *See* Mot. for

When operating in MSC mode, the Accused Cameras (identified in Tables 12 and 13 of the Final Infringement Contentions) do not infringe the 399 Patent or the 449 Patent (either literally or under the doctrine of equivalents) based on the External Accessories because such External Accessories do not meet the “data transmit/receive device” claim limitation. The External Accessories, identified in Tables 1-4 and 6 of the Final Infringement Contentions, are audio sources, audio/video sources, flashes, external data devices (including GPs units, bar code scanner units, and remote control devices), lenses, and printers. Papst’s motion for Rule 56(d) discovery [Dkt. 479] is denied with regard to that portion of the motion dealing with the “data transmit/receive device” claim limitation. A memorializing Order accompanies this Opinion.

Date: May 8, 2013

/s/
ROSEMARY M. COLLYER
United States District Judge

Leave to File Surreply [Dkt. 516]. Because surreplies are disfavored in this District and because the Camera Manufacturers’ Reply did not raise new issues, Papst’s motion to file a surreply will be denied. *See Crummey v. Social Security Admin.*, 794 F. Supp. 2d 46, 62 (D.D.C. 2011).

UNITED STATES DISTRICT COURT
FOR THE DISTRICT OF COLUMBIA

<hr/>	
IN RE PAPST LICENSING GMBH & CO. KG)
LITIGATION)
)
This document relates to)
)
ALL CASES)
)
)
)
)
<hr/>)

Misc. Action No. 07-493 (RMC)

MDL No. 1880

**OPINION RE: CAMERA MANUFACTURERS’ MOTION FOR SUMMARY
JUDGMENT OF NONINFRINGEMENT BASED ON THE LIMITATION OF AN
“INPUT/OUTPUT [STORAGE] DEVICE CUSTOMARY IN A HOST DEVICE”**

Papst Licensing GmbH & Co. KG, a German company, sues multiple manufacturers of digital cameras for alleged infringement of two patents owned by Papst: U.S. Patent Number 6,470,399 (399 Patent) and U.S. Patent Number 6,895,449 (449 Patent). The Camera Manufacturers¹ have moved for summary judgment of noninfringement with respect to the “input/output [storage] device customary in a host device” claim limitation in both Patents. The Camera Manufacturers’ motion for summary judgment will be granted in part and denied in

¹ This Multi District Litigation currently consists of First and Second Wave Cases. The “First Wave Cases” are: *Fujifilm Corp. v. Papst*, 07-cv-1118; *Matsushita Elec. Indus. Co., Ltd. v. Papst*, 07-cv-1222; *Papst v. Olympus Corp.*, 07-cv-2086; *Papst v. Samsung Techwin Co.*, 07-cv-2088; *Hewlett-Packard Co. v. Papst*, 08-cv-865; and *Papst v. Nikon Corp.*, 08-cv-985. The “Second Wave Cases” currently are: *Papst v. Canon*, 08-cv-1406; *Papst v. Eastman Kodak*, 08-cv-1407; *Papst v. Sanyo*, 09-cv-530. The Camera Manufacturers seeking summary judgment here are parties in the First Wave Cases; they are: Fujifilm Corporation; Fujifilm U.S.A., Inc.; Fujifilm Japan; Matsushita Electric Industrial Co., Ltd.; Victor Company of Japan, Ltd.; Olympus Corporation; Olympus Imaging America Inc.; Samsung Techwin Co., Ltd.; Samsung Opto-Electronics America, Inc.; Panasonic Corporation of North America; JVC Company of America; Hewlett-Packard Company (HP); Nikon Corporation; and Nikon, Inc. Papst’s infringement contentions against HP have been stricken and discovery has been stayed.

part. The Picture Transfer Protocol accused devices do not meet the “customary in a host device” limitation because they identify themselves to a computer as still image capture devices (scanners) that could not be found inside computers at the time of the invention. In contrast, the Mass Storage Class accused devices meet the “customary in a host device” limitation because they identify themselves as mass storage devices (hard drives) that were commonly found inside computers at the relevant time. Summary judgment of noninfringement will be granted with regard to the Picture Transfer Protocol accused devices only.

I. FACTS²

A. The Invention

The invention at issue is a “Flexible Interface for Communication Between a Host and an Analog I/O Device Connected to the Interface Regardless of the Type of the I/O Device.” 399 Patent, Title; 449 Patent, Title. An I/O device is an input/output device, repeatedly referred to as a “data transmit/receive device” in the Patents. *See, e.g.*, 399 Patent 3:43-44 & 13:1-2; 449 Patent 4:6-7 & 11:63-64.³ The 449 Patent is a continuation or divisional patent⁴ that is quite similar to the 399 Patent. They share the same block diagram drawings, Figures 1 and 2. *See, e.g.*, 399 Patent 9:15-16 (“Figure 2 shows a detailed block diagram of an interface device, according to the present invention”); 449 Patent 8:15-16 (same). The 399 and 449 Patents also share much of the same specification.

² This motion is one of eight filed by the Camera Manufacturers. In the interest of timely disposition of all, the Court does not recite the full background and assumes familiarity with its prior rulings. *See, e.g.*, Modified Claims Construction Op. [Dkt. 336]; Sanctions Op. [Dkt. 429].

³ Citations to the Patents are to “column number: line number.”

⁴ The 399 Patent was issued on October 22, 2002, with an application date of March 3, 1998; the 449 Patent was issued on May 17, 2005, with an application date of August 15, 2002. Because it is a continuation patent, Papst asserts that the 449 Patent has priority dating back to the 399 Patent.

The “interface device” is designed to provide data transfer between a data transmit/receive device and a computer without the need for special software; this is accomplished by telling the computer that the interface device is a transmit/receive device already known to the computer (and for which the computer already has drivers, i.e., software), regardless of what kind of data transmit/receive device actually is attached to the interface device. 399 Patent, Abstract; 449 Patent, Abstract. The specification describes communication between the interface device and a computer, explaining that in response to a query from the computer, the interface device sends a signal to the computer indicating that, for example, a hard disk drive is attached to the interface device:

Preferably, the interface device according to the present invention simulates a hard disk with a root directory whose entries are “virtual” files which can be created for the most varied functions. When the host device system with which the interface device according to the present invention is connected is booted and a data transmit/receive device is also attached to the interface device 10, usual BIOS routines or multi-purpose interface programs issue an instruction, known by those skilled in the art as the INQUIRY instruction, to the input/output interfaces in the host device. The digital signal processor 13 receives this inquiry instruction via the first connecting device and generates a signal which is sent to the host device (not shown) again via the first connecting device 12 and the host line 11. This signal indicates to the host device that, for example, a hard disk drive is attached at the interface to which the INQUIRY instruction was sent. . . .

Regardless of which data transmit/receive device at the output line 16 is attached to the second connecting device, *the digital signal processor 13 informs the host device that it is communicating with a hard disk drive.*⁵

⁵ The specification often refers to Figures 1 and 2 by identifying numbered elements as they appear in the Figures, such as the references to “the output line 16” and “the digital signal processor 13.”

399 Patent 5:67 & 6:1-22 (emphasis added); 449 Patent 4:66-67 & 5:1-22 (same). In other words, when a computer receives a signal from the interface device that the interface device is, for example, a hard disk drive, the computer communicates with the interface device using its customary software for a hard disk drive.

By fooling the computer into communicating using its own customary software, the interface device can fulfill its purpose—to provide “communication between a host device and a data transmit/receive device whose use is host device-independent and which delivers a high data transfer rate.” 399 Patent 3:24-27; 449 Patent 3:20-23 (same); *see* Claims Constr. Op. at 22 (the purpose of the invention is “to allow fast communication between dissimilar data transmit/receive devices and computers, without the need for special software drivers”); 399 Patent 4:23-27 (the Patents are “based on the finding that both a high data transfer rate and host device-independent use can be achieved if a driver for an input/output device customary in a host device, normally present in most commercially available host devices, is utilized,” instead of special driver software); 449 Patent 3:27-31 (same).

B. “Customary in a Host Device” Claim Limitation

Each of the asserted Patent Claims includes the “customary in a host device” claim limitation. That is, every independent claim of the 399 Patent requires the interface device to identify itself to the host device (computer) as an “input/output device customary in a host device,” and every independent claim of the 449 Patent requires the interface device to identify itself to the computer as a “storage device customary in a host device.” For example, Claim One of the 399 Patent states:

What is claimed is:

1. An interface device for communication between a host device, which comprises drivers for input/output devices customary in a host device and a multi-purpose interface, and a data

transmit/receive device, the data transmit/receive device being arranged for providing analog data, comprising:

a processor;

a memory;

a first connecting device for interfacing the host device with the interface device via the multi-purpose interface of the host device; and

a second connecting device for interfacing the interface device with the data transmit/receive device, the second connecting device including a sampling circuit for sampling the analog data provided by the data transmit/receive device and an analog-to-digital converter for converting data sampled by the sampling circuit into digital data,

wherein the interface device is configured by the processor and the memory to include a first command interpreter and a second command interpreter,

wherein the first command interpreter is configured in such a way that the command interpreter, when receiving an inquiry from the host device as to a type of a device attached to the multi-purpose interface of the host device, sends a signal, regardless of the type of the data transmit/receive device attached to the second connecting device of the interface device, to the host device *which signals to the host device that it is an input/output device customary in a host device*, whereupon the host device communicates with the interface device by means of the driver for the input/output device customary in a host device, and

wherein the second command interpreter is configured to interpret a data request command from the host device to the type of input/output device signaled by the first command interpreter as a data transfer command for initiating a transfer of the digital data to the host device.

399 Patent, Claim 1, 12:64-67, 13:1-13 (emphasis added). Claim One of the 449 Patent is similar; the emphasized language is identical, except that the term “storage device” is substituted for the term “input/output device.” See 449 Patent, Claim 1, 11:45-67 & 12:1-6.⁶ Each of the

⁶ Claim One of the 449 Patent provides:

asserted independent Claims contains similar language, indicating that the interface device identifies itself to the computer as an input/output or storage device customary in a computer and that the computer communicates with the interface device via drivers (software) for the identified input/out or storage device. *See* 399 Patent, Claims 1, 11, and 14; 449 Patent, Claims 1, 17, and 18.

What is claimed is:

1. An interface device for communication between a host device, which comprises drivers for input/output devices customary in a host device and a multi-purpose interface, and a data transmit/receive device comprising the following features:

a processor;

a memory;

a first connecting device for interfacing the host device with the interface device via the multi-purpose interface of the host device; and

a second connecting device for interfacing the interface device with the data transmit/receive device,

wherein the interface device is configured by the processor and the memory in such a way that the interface device, when receiving an inquiry from the host device as to the type of a device attached to the multi-purpose interface of the host device, sends a signal, regardless of the type of the data transmit/receive device attached to the second connecting device of the interface device, to the host device *which signals to the host device that it is a storage device customary in a host device*, whereupon the host device communicates with the interface device by means of the driver for the storage device customary in a host device, and

wherein the interface device is arranged for simulating a virtual file system to the host, the virtual file system including a directory structure.

449 Patent, Claim 1, 11:45-67 & 12:1-6 (emphasis added).

The Court construed the contested claims of the 399 and 449 Patents,⁷ finding that the phrase “an input/output device customary in a host device” in the 399 Patent means a “data input/output device that was normally present within the chassis of most commercially available computers at the time of the invention.”⁸ Modified Claims Construction Op. [Dkt. 336] (Claims Constr. Op.) at 59; *see also* Order [Dkt. 337] at 3-4. Thus, “a storage device customary in a host device” in the 449 Patent was construed to mean a “storage device that was normally present within the chassis of most commercially available computers at the time of the invention.” Claims Constr. Op. at 59. The Court interpreted the phrase “customary in a host device” as including a temporal limitation:

A court must interpret the words of a contested claim from the perspective of one skilled in the art at the time of invention. *See Phillips v. AWH Corp.*, 415 F.3d 1303, 1313 (Fed. Cir. 2005)]. The word “customary” is time-dependent, like the word “conventional” construed by the court in *Muniauction, Inc. v. Thomson Corp.*, 532 F.3d 1318, 1326 (Fed. Cir. 2008). There, the court determined that “conventional” when modifying the term “internet browser” meant web browsers in existence at the time of the invention. *See id.*; accord *PC Connector Solutions LLC v. SmartDisk Corp.*, 406 F.3d 1359, 1363-64 (Fed. Cir. 2005) (input/output port “normally” connectible to a computer port meant technology existing at the time of the invention). A claim cannot be interpreted to have different meanings at different times. *See PC Connector*, 406 F.3d at 1363. The word “customary” means customary in a host computer at the time of the invention.

⁷ Pursuant to *Markman v. Westview Instruments, Inc.*, 517 U.S. 370 (1996), a court is required to construe the contested claims of the patents before a jury can determine whether the accused products infringe. In claims construction, a court must interpret the words of each contested claim from the perspective of one skilled in the art at the time of invention, in light of the patent documents and the prosecution history. *Phillips v. AWH Corp.*, 415 F.3d 1303, 1313 (Fed. Cir. 2005).

⁸ The Court also defined the “the driver for the input/output [storage] device customary in a host device” as “the customary driver(s) in a host device used to communicate with customary internal and external input/output device(s), which driver(s) were normally present within the chassis of most commercially available computers at the time of the invention.” Claims Constr. Op. at 59.

Id. at 55-56. “At the time of the invention” means as of March 3, 1998 when inventor Michael Tasler applied for the 399 Patent. *Id.* at 55.⁹

Also, the Court interpreted the “customary in a host device” claim limitation to reflect a location restriction—that “in” a host device meant “inside the chassis of a computer.” The Court reached this conclusion as follows:

[T]he word “in” should be construed in accordance with its ordinary meaning to mean “within,” not “with respect to” as Papst proposes. Papst’s construction ignores the word “in,” rendering it superfluous, and such a construction is disfavored. *See Merck [& Co., Inc. v. Teva Pharmaceuticals USA, Inc., 395 F.3d 1364, 1372 (Fed. Cir. 2005)]* (a construction that gives meaning to all the terms of the claim is preferred over one that does not).

Id. at 58.

C. Papst’s Allegations

The immediate motion for summary judgment is based on the “customary in a host device” claim limitation. Papst alleges that certain accused devices manufactured and/or sold by the Camera Manufacturers are “interface devices” that infringe Claims 1-3, 5, 7, 11, and 14-15 of the 399 Patent and Claims 1-2, 6-9, 12-13, and 15-18 of the 449 Patent. The accused products include digital cameras, camcorders, and digital voice recorders.¹⁰ Specifically, Papst’s Final Infringement Contentions assert that (1) the Mass Storage Class (MSC) accused devices listed on Table 12 infringe the 399 Patent; (2) the MSC accused devices listed on Table 13 infringe the 449 Patent; and (3) the Picture Transfer Protocol (PTP) accused devices listed on Table 14 infringe the 399 Patent. *See* Final Infringement Contentions (FICs) [Dkt. 416], Tables

⁹ Mr. Tasler invented and patented the “interface device” and later sold the Patents to Papst. The invention was never produced or used.

¹⁰ Papst was not granted leave to add cell phones and MP3 players to this litigation. *See* Sanctions Op. at 12.

12 & 13 (MSC Accused Devices) & Table 14 (PTP Accused Devices).¹¹ PTP and MSC relate to how a device is recognized by a computer. When a user connects an accused device to a computer, depending on the mode setting for the device, the computer will recognize the device as a PTP device or as a MSC device.

The Camera Manufacturers seek summary judgment of noninfringement, arguing that the MSC Accused Devices and the PTP Accused Devices do not identify themselves as data input/output or storage devices that were normally present within the chassis of most commercially available computers at the time of the invention, *i.e.*, in 1998. *See* Mot. for Summ. J. Re “Customary in a Host Device” Limitation [Dkt. 449]; Reply [Dkt. 501]. The Camera Manufacturers argue that the PTP Accused Devices identify themselves as USB still image capture devices and the MSC Accused Devices identify themselves as USB Mass Storage Class devices, both of which are found outside the computer chassis and which did not exist in 1998. In this motion for summary judgment, the Camera Manufacturers seek judgment as to every device accused in this case—they seek a ruling that the PTP Accused Devices do not infringe the 399 Patent and that the MSC Accused Devices do not infringe the 399 or the 449 Patents.¹² Papst opposes. *See* Opp’n [Dkt. 474].

II. LEGAL STANDARD

Under Rule 56 of the Federal Rules of Civil Procedure, summary judgment shall be granted “if the movant shows that there is no genuine dispute as to any material fact and the movant is entitled to judgment as a matter of law.” Fed. R. Civ. P. 56(a); *accord Anderson v.*

¹¹ Some accused products are alleged to operate in both MSC mode and PTP mode. *See, e.g.*, FICs, Table 12 (asserting that Fujifilm model V10 is MSC-capable); *id.*, Table 14 (asserting that Fujifilm model V10 is PTP-capable).

¹² Papst never alleged that the PTP Accused Devices infringe the 449 Patent.

Liberty Lobby, Inc., 477 U.S. 242, 247 (1986). On summary judgment, the burden on a moving party who does not bear the ultimate burden of proof in the case may be satisfied by making an initial showing that there is an absence of evidence to support the nonmoving party's case.

Celotex Corp. v. Catrett, 477 U.S. 317, 325 (1986). This burden "may be discharged by 'showing'—that is, pointing out to the district court—that there is an absence of evidence to support the nonmoving party's case." *Id.*

The burden then shifts to the nonmovant to demonstrate the existence of a genuine issue of material fact. The nonmovant may not rest on mere allegations or denials, but must instead by affidavit or otherwise, present specific facts showing that there is a genuine issue for trial. *See* Fed. R. Civ. P. 56(c); *Celotex*, 477 U.S. at 324; *see also Greene v. Dalton*, 164 F.3d 671, 675 (D.C. Cir. 1999) (nonmovant must present specific facts that would enable a reasonable jury to find in its favor).

In ruling on a motion for summary judgment, the court must draw all justifiable inferences in the nonmoving party's favor. *Anderson*, 477 U.S. at 255. A nonmoving party, however, must establish more than "the mere existence of a scintilla of evidence" in support of its position. *Id.* at 252. In addition, if the evidence "is merely colorable, or is not significantly probative, summary judgment may be granted." *Anderson*, 477 U.S. at 249-50 (citations omitted). Summary judgment is properly granted against a party who "after adequate time for discovery and upon motion . . . fails to make a showing sufficient to establish the existence of an element essential to that party's case, and on which that party will bear the burden of proof at trial." *Celotex*, 477 U.S. at 322.

Summary judgment can be granted in a patent case if there is no dispute over the structure of the accused products, at which point the question of infringement "collapses" into

the question of claim construction and may be resolved by the court. *Desper Prods. Inc. v. QSound Labs Inc.*, 157 F.3d 1325, 1332-33 (Fed. Cir. 1998). The burden of proving infringement rests on the patent holder. *Welker Bearing Co. v. PHD, Inc.*, 550 F.3d 1090, 1095 (Fed. Cir. 2008).

III. ANALYSIS

A. Literal Infringement and the Doctrine of Equivalents

To determine whether a patent has been infringed, a court must (1) construe the patent and (2) compare the devices accused of infringing to the construed patent claims. *Mars, Inc. v. H.J. Heinz Co., LP*, 377 F.3d 1369, 1373 (Fed. Cir. 2004). The party alleging infringement bears the burden of proof. *Jazz Photo Corp. v. Int'l Trade Comm'n*, 264 F.3d 1094, 1102 (Fed. Cir. 2001). Since this Court already has interpreted the Patents, the Court now proceeds to step two, a comparison of the accused cameras to the allegedly infringed Claims.

Patent infringement can be either (1) literal infringement or (2) infringement under the doctrine of equivalents. To prove literal infringement, a patentee must prove that the accused product satisfies each and every limitation of a claim. *Warner-Jenkinson Co. v. Hilton-Davis Chem. Co.*, 520 U.S. 17, 29 (1997); *Rohm & Haas v. Brotech Corp.*, 127 F.3d 1089, 1092 (Fed. Cir. 1997). A patent is literally infringed “when each of the claim limitations reads on, or in other words is found in, the accused device.” *Allen Eng'g Corp. v. Bartell Indus., Inc.*, 299 F.3d 1336, 1345 (Fed. Cir. 2002). If a device does not infringe an independent claim of a patent, the device cannot infringe a claim dependent on that independent claim.¹³ *Wahpeton Canvas Co., Inc. v. Frontier, Inc.*, 870 F.2d 1546, 1552 n.9 (Fed. Cir. 1989).

¹³ A claim in “dependent form” incorporates by reference all the limitations of the claim on which it depends and adds something new, giving it a narrower scope than the claim from which it depends. See 35 U.S.C. § 112; *Phillips*, 415 F.3d at 1315.

Alternatively, a plaintiff can show infringement under the doctrine of equivalents. The essential inquiry in determining whether there has been infringement under this doctrine is whether “the accused product or process contains elements identical or equivalent to each claimed element of the patented invention.” *Am. Calcar, Inc. v. Am. Honda Motor Co.*, 651 F.3d 1318, 1338 (Fed. Cir. 2011) (quoting *Warner-Jenkinson*, 520 U.S. at 40). An element in an accused product is deemed to be equivalent to a claim limitation if the difference between the two is “insubstantial” to a person of ordinary skill in the art. *Wavetronix v. EIS Elec. Integrated Sys.*, 573 F.3d 1343, 1360 (Fed. Cir. 2009). In order to assess insubstantiality, a court considers whether an element of the accused product “performs substantially the same function in substantially the same way to obtain the same result” as the patented invention. *Am. Calcar*, 651 F.3d at 1338. This is often referred to as the “function/way/result test.” *Id.* A patentee alleging infringement under the doctrine of equivalents must submit particularized evidence of equivalence and must explain specifically why the difference between what the claims literally require and what the accused products actually do is “insubstantial.” *Id.*

B. PTP Accused Devices

Papst alleges that PTP Accused Devices infringe the 399 Patent. However, Papst has admitted that a device in PTP mode will be recognized as an “image class device, such as a scanner.” FICs at 38. Because a still image capture device, such as a scanner, was not ordinarily present within the chassis of a computer at the time of the invention, Papst has conceded that the PTP Accused Devices do not literally infringe the 399 Patent. FICs at 4.

Instead, Papst alleges that the PTP Accused Devices infringe the 399 Patent under the doctrine of equivalents. *Id.* Papst argues that although a PTP Accused Device identifies itself as a USB still image capture device found *outside* a computer, such a response to the

inquiry is the equivalent of identifying itself as a device located *inside* a computer because the Patent really means “in a computer system” and not “inside the chassis of a computer.” During claims construction, the Court rejected this precise argument:

The Camera Manufacturers again assert that “in” means “within the chassis of the host computer.” CMs’ *Markman* Br. 29. Papst suggests that an input/output device “in” a computer should be construed more broadly to mean “with respect to,” as in “a hardware device that inputs or outputs data with respect to a host computer.” Papst’s App. at 4. “We don’t read in as requiring it to be inside. It means part of the system.” Tr. 2:80 (Papst).

The parties’ conflicting interpretations arise from the garbled language of the Claims. The specification clarifies that drivers must be internal to the host device: “[d]rivers for I/O devices customary in a host device which are found in practically all host devices.” 399 Patent, col. 4:27-30; 449 Patent, col. 3:31-34. But in describing such drivers, the specification refers to drivers for printers. The parties agree that printers are not inside a computer. Tr. 2:80 (Papst); Tr. 2:87 (CMs).

The specification expressly defines “drivers customary in a host device” in relation to the devices that such drivers direct. Those devices described are both inside and outside a computer. However, the interface device “signals to the host device that it is an input/output device customary in a host device.” The phrase “customary in a host device” refers to the immediately antecedent noun “device;” there is no other antecedent word that the phrase reasonably could modify. Thus, the input/output [device] must be “customary in a computer.” And the word “in” should be construed in accordance with its ordinary meaning to mean “within,” not “with respect to” as Papst proposes. Papst’s construction ignores the word “in,” rendering it superfluous, and such a construction is disfavored. *See Merck*, 395 F.3d at 1372 (a construction that gives meaning to all the terms of the claim is preferred over one that does not). Papst’s assertion—that the Patent must mean input/output devices customary in a *computer system* because the specification refers to drivers for devices both inside and outside the chassis of the computer—might be what the inventor meant to say when he wrote his Patent. But the Patent does not say that the interface device “signals to the host device that it is an input/output device *for which the host device has drivers that are* customary in a host device.” The Court must construe the claims of the Patent as they are written.

Claims Constr. Op. at 58-59. Accordingly, the Court held that “an input/output [storage] device customary in a host device” means a “data input/output [storage] device that was normally present within the chassis of most commercially available computers at the time of the invention,” specifically finding that the phrase did *not* mean an input/output [storage] device normally present within a computer system.¹⁴

In making its doctrine of equivalents argument, Papst again ignores the word “in,” arguing that the PTP Accused Devices operate in the same manner as the invention, whether they identify themselves as devices customarily found inside or outside the chassis of a computer. The problem with Papst’s argument is that the doctrine of equivalents cannot be used in a way that completely vitiates a claim limitation. “An element of an accused product or process is not, as a matter of law, equivalent to a limitation of the claimed invention if such a finding would entirely vitiate the claim.” *Freedman Seating Co. v. Am. Seating Co.*, 420 F.3d 1350, 1358 (Fed. Cir. 2005). Equivalence must be assessed on a limitation-by-limitation basis. *Id.* Because every element of a patent claim is material to defining the scope of the invention, the doctrine of equivalents “must be applied to individual elements of the claim, not to the invention as a whole. It is important to ensure that the application of the doctrine, even as to an individual element, is not allowed such broad play as to effectively eliminate that element in its entirety.” *Warner-Jenkinson*, 520 U.S. at 29-30. Further, “the doctrine of equivalents cannot be used to erase meaningful structural and functional limitations of the claim on which the public is entitled to

¹⁴ By asserting that “in a host device” means “within a computer system as a whole” Papst essentially seeks reconsideration of claims construction. Papst fails to meet the standard for reconsideration. *See Singh v. George Wash. Univ.*, 383 F. Supp. 2d 99, 101 (D.D.C. 2005) (reconsideration may be permitted when a court has patently misunderstood a party, has made a decision outside the adversarial issues presented to the court by the parties, has made an error not of reasoning but of apprehension, or where a controlling or significant change in the law or facts has occurred since the submission of the issue to the court.)

rely in avoiding infringement.” *Conopco, Inc. v. May Dep’t Stores Co.*, 46 F.3d 1556, 1562 (Fed. Cir. 1994).

The doctrine of equivalents does not apply where the accused device contains the “antithesis of the claimed structure.” *Planet Bingo LLC v. GameTech Int’l, Inc.*, 472 F.3d 1338, 1345 (Fed. Cir. 2006). The Federal Circuit repeatedly has rejected equivalence arguments such as the one Papst makes here. *See, e.g., Planet Bingo*, 472 F.3d at 1344-45 (rejecting doctrine of equivalents analysis asserting that “before” was the equivalent of “after”); *Asyst Techs., Inc. v. Emtrak Inc.*, 402 F.3d 1188, 1195 (Fed. Cir. 2005) (finding that an “unmounted” microcomputer is not the equivalent of a “mounted” microcomputer); *Seachange Int’l, Inc. v. C-COR Inv.*, 413 F.3d 1361, 1378 (Fed. Cir. 2005) (“indirect” connections between processors are not the equivalent of “direct” connections). Specifically, limitations on location must be met by an equivalent. For example, in *Cooper Cameron Corp. v. Kvaerner Oilfield Prods., Inc.*, 291 F.3d 1317 (Fed. Cir. 2002), the Federal Circuit refused to find infringement under the doctrine of equivalents where the accused structure (a “workover port”) was located “above” two plugs and the patent claim term specified that the workover port was “between” two plugs. Similarly, the Federal Circuit found no infringement under the doctrine of equivalents in *Sage Prods., Inc. v. Devon, Indus., Inc.*, 126 F.3d 1420, 1425-26 (Fed. Cir. 1997), because the accused product had an elongated slot “within,” instead of “on top of,” the claimed container.

Papst insists that its doctrine of equivalents claim is viable under *Voda v. Cordis Corp.*, 536 F.3d 1311 (Fed. Cir. 2008) and *Cordis Corp. v. Boston Scientific Corp.*, 561 F.3d 1319 (Fed. Cir. 2009), but in those cases the application of the doctrine of equivalents did not negate the claim limitation. In *Voda*, the accused products were catheters used by cardiologists. The alleged infringer asserted that the catheters, which were slightly curved, could not meet the

“straight portion” limitation in the asserted patent claims. 536 F.3d at 1326-27. The Federal Circuit upheld the lower court’s finding of infringement by equivalents because an expert had testified that the difference in shape between the curved portion of the accused catheters and the straight portion of the patented device was so insubstantial that “cardiologists would have difficulty distinguishing the two during use.” *Id.* at 1327. The court found that the difference between the characteristic of the accused device (curved) and the claim limitation (straight) was insubstantial. The equivalence argument did not vitiate the claim limitation; instead, the court determined that the accused product met the claim limitation. In *Boston Scientific*, the alleged infringer argued that the accused devices (stents) did not infringe the “corners” limitation of the patent because the stents had “circular arcs.” 561 F.3d at 1323, 1329-31. The Federal Circuit determined that the “circular arcs” in the accused products were actually “rounded corners” that met the claim limitation under the doctrine of equivalents. *Id.* at 1330. As in *Voda*, the equivalence argument did not nullify the claim limitation. *Id.* (the equivalence theory that the “circular arcs” are “corners” did not render the claim limitation meaningless).

In contrast to *Voda* and *Boston Scientific*, Papst’s equivalence theory here eviscerates the “customary *in* a host device” claim limitation. Under Papst’s argument, “in” means “outside,” and thus *any* input/output [storage] device would satisfy the claim limitation. The Court must reject Papst’s equivalence argument because it renders meaningless the claim term “in.”

Papst’s equivalency argument also conflicts with the Court’s interpretation of the term “host device.” Papst contends that the Patents have “an expansive view of what comprises a ‘host device,’” such that a “host device” is really a computer system, including all the peripherals that might be attached to a computer, such as a mouse, a printer, and a scanner.

Opp'n at 16-18.¹⁵ Papst argues that “components normally outside the chassis may be equivalents of components normally inside the chassis.” *Id.* at 17. However, “host device” was defined during claims construction as “a general purpose computer that connects to and directs the operation of peripherals” Claims Constr. Op. at 27. The Court rejected Papst’s expansive view, adopting the definition provided in the specification, that the “host device” is a computer. *See id.* at 24-25 (citing 399 Patent 1:9-11 (“The present invention relates to the transfer of data and in particular to interface devices for communication between a *computer or host device* and a data transmit/receive device”) (emphasis added); 449 Patent 1:13-15 (same)).

Papst further insists that the “customary in a host device” claim limitation really deals with “the signals sent by the PTP [Accused] Devices in response to an inquiry instruction, not whether any particular input/output devices are inside the chassis or outside.” Opp’n [Dkt. 474] at 18. This argument is based on what Papst wishes the Patents said, not on the actual language of the Patents. The Court’s claim construction was based on the text of the claims, the specifications, and the prosecution history. *See Phillips v. AWH Corp.*, 415 F.3d 1303, 1313 (Fed. Cir. 2005) (patent claim must be construed from the viewpoint of one skilled in the art at the time of invention and in light of the patent documents and the prosecution history). The Court did not and cannot construe the Patents to say what Papst wishes they said; instead, the Court must construe the claims of the Patents as they are written. The phrase “customary in a host device” modifies the word “device” and thus the input/output device must be “customary in

¹⁵ Papst has been inconsistent in its position. In the Final Infringement Contentions, Papst noted that a printer would not be considered a “host device,” and instead would be considered a “data transmit/receive device.” FICs at 25. In opposition to summary judgment on this claim limitation, Papst now claims that a printer is part of a host device. Opp’n at 17.

a computer.” Claims Constr. Op. at 58. The Court rejects Papst’s attempt, again, to read the “customary in a host device” phrase out of the Patents. *See Merck & Co., Inc. v. Teva Pharms. USA, Inc.*, 395 F.3d 1364, 1372 (Fed. Cir. 2005) (a construction that gives meaning to all the terms of the claim is preferred over one that does not).

In response to an inquiry from a computer, the PTP Accused Devices identify themselves as still image capture devices, like scanners. Because such devices could not be found inside the chassis of computers at the time of the invention, the PTP Accused Devices fail to meet the “customary in a host device” claim limitation. *See Celotex*, 477 U.S. at 325 (the burden on a moving party who does not bear the burden of proof may be discharged by pointing out that there is an absence of evidence to support the nonmoving party’s case). The burden shifts to Papst to show a genuine dispute of material fact by presenting some evidence that still image capture devices could be found within the chassis of a computer in 1998.¹⁶ Because Papst has failed to do so, the motion for summary judgment of noninfringement will be granted in favor of the Camera Manufacturers with regard to the PTP Accused Devices.¹⁷ *See id.* at 322

¹⁶ Papst notes that some of the PTP Accused Devices record video and sound as well as still images and objects to the Camera Manufacturers’ characterization of a still image capture device as one that produces digital still images like a camera or a scanner. *See* Opp’n at 25 (criticizing Berg. Decl. [Dkt. 449-3] ¶ 20)). The Camera Manufacturers do not dispute that PTP Accused Devices such as camcorders capture video and sound in addition to still images. The point is not relevant to the issue before the Court—which is whether a still image capture device could be found inside a computer in 1998, and thus whether the PTP Accused Devices on Table 14 (devices that identify themselves as still image capture devices) meet the “customary in a host device” limitation.

¹⁷ The Camera Manufacturers also argue that USB still image capture devices did not exist at the time of the invention and the USB protocol for still image capture devices did not yet exist. Because the Court holds that the PTP Accused Devices do not meet the “customary in a host device” limitation (since they identify themselves as a scanner-type device, not found inside the chassis of a computer at the relevant time), the Court does not reach this argument.

(summary judgment can be granted against a party who fails to make a showing sufficient to establish an element essential to the party's case, on which he bears the burden of proof).

C. MSC Accused Devices

Papst alleges that the MSC Accused Devices infringe the 399 and 449 Patents.

Papst further allege that the MSC Accused Devices meet the "customary in a host device" claim limitation because a device operating in MSC mode will be recognized by a computer as a "mass storage class device, such as a disk drive." FICs at 36. The Patents expressly identify hard disk drives as the preferred input/output devices that are emulated by the interface device. *See* 399 Patent 5:6-9 ("The interface device according to the present invention therefore simulates, both in terms of hardware and software, the way in which a conventional input/output device functions, preferably that of a hard disk drive."); 449 Patent 4:10-13 (same).

The Camera Manufacturers agree "that the general category of mass storage devices, such as hard drives, were [sic] available at the time of the invention, and that they were often found within the chassis of computers at that time (as they are now)." Reply [Dkt. 501] at 13. However, the Camera Manufacturers contend that an MSC Accused Device does not identify itself to a host computer simply as a "disk drive"—instead, it identifies itself as a USB Mass Storage Class device,¹⁸ which is a peripheral typically found *outside* the chassis of computers and which did not exist until *after* the time of the invention. Reply at 14. Because USB Mass Storage Class devices did not exist at the time of the invention and thus could not be found inside the chassis of a computer at that time, the Camera Manufacturers argue that the MSC Accused Devices do not meet the "customary in a host device" claim limitation.

¹⁸ The Camera Manufacturer's expert, Paul Berg, states only that the MSC Accused Devices identify themselves as "Mass Storage Class" devices. Berg Decl. ¶ 29 (an MSC device will respond with a value that corresponds to Mass Storage Class); *id.*, Ex. 12 at 11, "Table 4.5 – Bulk-Only Data Interface Descriptor."

Papst agrees that USB Mass Storage Class devices were not available in 1998 and that the MSC Accused Devices communicate using the Mass Storage Class specification. Even so, Papst avers that the MSC Accused Devices meet the “customary in a host device” limitation by identifying themselves *generally* as mass storage devices (hard drives), which were commonly found inside computers in 1998.

Papst has the better part of this argument. A hard disk drive does not become some other type of device just because it is attached to, or communicates with, a computer using a USB connection and USB protocol. The Patents require only that the interface device identify itself to a computer as a “device” that is customary in a host device (preferably a hard disk drive). The Patents do not claim that the interface device has a “connector” that is customary in a host device or that the interface device uses a “protocol for communication” that is customary in a host device.

More specifically, the Patents do not require that the multipurpose interface of the host computer be “customary” or that it be any particular type of connector. The Patents refer to the attachment of the interface device to a host device via a multi-purpose interface as follows:

wherein the [interface device] . . . when receiving an inquiry from the host device as to a type of a device attached to the *multi-purpose interface* of the host device, sends a signal, regardless of the type of the data transmit/receive device attached to the second connecting device of the interface device, to the host device which signals to the host device that it is an input/output device customary in a host device.

399 Patent 12:64-67, 13:1-5: (emphasis added); 449 Patent 11:60-67 (same, except substituting “storage device” for “input/output device”). The Court defined “multi-purpose interface” as “a communication interface designed for use with multiple devices that can have different functions from each other.” Claims Constr. Op. at 33. This definition is sufficiently broad to include any type of connector, including a USB connector.

Similarly, the Patents do not require that the interface device communicate with the computer using a particular communication protocol. With regard to a preferred embodiment of the invention, the specifications describe an interface device that communicates with a computer as follows:

(1) When the interface device is connected to a computer and a data transmit/receive device and the computer is booted up, the normal BIOS (Basic Input/Output System) routines or multi-purpose interface programs of the computer issue an INQUIRY instruction. *See* 399 Patent 6:3-10; 449 Patent 5:2-9.

(2) The interface device's digital signal processor receives this instruction and generates a signal to the computer, indicating that, for example, a hard disk drive is attached. 399 Patent 6:10-15; 449 Patent 5:9-15.

(3) Upon receiving this response, the computer asks to read the boot sequence of a customary hard disk drive, and the interface device sends a virtual boot sequence, including the drive type, the starting position and the length of the file allocation table, and the number of sectors. 399 Patent 6:22-32; 449 Patent 5:22-32. Once the computer has received this data, it assumes that the interface device is a hard disk drive. 399 Patent 6:32-35; 449 Patent 5:32-35.

The Camera Manufacturers' expert, Paul Berg, and Papst's expert, Dr. C.

Douglass Locke, agree that when an MSC Accused Device is attached to a computer, the computer sends an inquiry called a "Get_Descriptor" command, seeking information concerning the type of device attached to the computer. Berg. Decl. [Dkt. 449-3] ¶ 39; Lock Third Decl. ¶ 586. In response to the "Get_Descriptor" command, an MSC Accused Device will send descriptor values. In the MSC specification, these descriptors are the bInterfaceClass descriptor, the bInterfaceSubClass descriptor, and the bInterfaceProtocol descriptor. Berg Decl. ¶ 29; Locke Third Decl. ¶ 587. An MSC Accused Device will respond with a value of 08h for the bInterfaceClass field, which corresponds to "Mass Storage Class." Berg Decl. ¶ 29; Locke Third Decl. ¶ 588. The drivers that the computer then uses to communicate with the MSC Accused

Devices are the drivers that the computer would use to communicate with a hard disk drive. Locke Third Decl. ¶ 590; FICs 36-38 (in response to the inquiry command from the computer, the MSC Accused Devices respond with descriptors that identify themselves as hard disk drives).

Papst has presented a genuine dispute of material fact regarding whether the MSC Accused Devices meet the “customary in a host device” claim limitation because a device operating in MSC mode will be recognized by a computer as a mass storage class device, such as a disk drive. The fact that the MSC Accused Devices use a USB connector does not preclude Papst’s claim of infringement. The Camera Manufacturers’ motion will be denied on this ground.

D. New Theory of Infringement

Papst also asserts a new theory of infringement, arguing that in addition to identifying themselves as Mass Storage Class devices, MSC Accused Devices also identify themselves as SCSI Direct Access devices.¹⁹ See Opp’n at 8-10. However, Papst failed to allege infringement based on this theory in its Final Infringement Contentions, and it is too late to do so now. The Court ordered Papst to file final infringement contentions in compliance with detailed requirements. See Mot. for Sanctions [Dkt. 388], Ex. A (Tr. of Aug. 31, 2010 Hearing); Sixth Prac. & Pro. Order (Sixth PPO) [Dkt. 372]. Because Papst filed Final Infringement Contentions that failed to comply with Court’s orders, the Court barred Papst from advancing any arguments

¹⁹ “SCSI” stands for “small computer system interface.” In alleging that the MSC Accused Devices infringe the “customary in a host device” limitation, the Final Infringement Contentions allege three examples: (1) the Panasonic DMC-LXI Digital Camera signals that it is “a disk drive compatible with a SCSI command set”; (2) an MSC Accused Device identifies itself as a “disk drive compatible with a ATAPI command set”; and (3) when an MSC Accused Device is attached to an Apple Macintosh using the OS X Snow Leopard operating system, the computer loads three drivers (IOUSBMassStorageClass, IOSCSIBlockCommandsDevice, and filesystems.msdsdfs) which are used when an actual hard disk drive is attached to the interface of an Apple Macintosh computer. FICs at 37-38. The FICs do not accuse any devices of infringement because they identify themselves as SCSI Direct Access devices.

for infringement (or against claims of noninfringement) that either (1) are not based solely on this Court's constructions of the Patents or (2) are not already set forth specifically and explicitly in Papst's Final Infringement Contentions. *See* Sanctions Op. [Dkt. 429] at 13; Sanctions Order [Dkt. 430] at 2. Accordingly, Papst is barred from asserting this new theory of infringement.²⁰

E. Additional Discovery

At one time, Papst sought more discovery regarding the "input/output [storage] device customary in a host device" claim limitation. *See* Mot. for 56(d) Disc. [Dkt. 479] at 23-31. Papst later withdrew the request for more discovery as to this claim limitation. Papst Reply [Dkt. 515]. Thus, Papst's request for more discovery regarding the "customary in a host device" claim limitation will be denied as moot.

IV. CONCLUSION

The Camera Manufacturers' motion for summary judgment of noninfringement with respect to the "input/output [storage] device customary in a host device" claim limitation [Dkt. 449] will be granted in part and denied in part.²¹ Summary judgment of noninfringement of the 399 Patent will be granted in favor of the Camera Manufacturers with respect to the PTP Accused Devices, as they do not meet the "customary in a host device" claim limitation. Summary judgment of noninfringement will be denied with respect to the MSC Accused

²⁰ Papst had not alleged that the MSC Accused Devices infringe under the doctrine of equivalents. Papst is barred from now making such a claim. *See* Sanctions Op. [Dkt. 429] at 13; Sanctions Order [Dkt. 430] at 2.

²¹ As it has in each of the eight motions for summary judgment in this case, Papst moved to file a surreply in opposition to the Camera Manufacturers' motion for summary judgment with respect to the "input/output [storage] device customary in a host device" claim limitation. *See* Mot. for Leave to File Surreply [Dkt. 514]. Because surreplies are disfavored in this District and because the Camera Manufacturers' Reply [Dkt. 501] did not raise new issues, Papst's motion to file a surreply will be denied. *See Crummey v. Social Security Admin.*, 794 F. Supp. 2d 46, 62 (D.D.C. 2011).

UNITED STATES DISTRICT COURT
FOR THE DISTRICT OF COLUMBIA

<hr/>)	
IN RE PAPST LICENSING GMBH & CO. KG)		
LITIGATION)		
)	Misc. Action No. 07-493 (RMC)	
This document relates to)		
)	MDL No. 1880	
ALL CASES)		
)		
<hr/>)		

**OPINION RE: CAMERA MANUFACTURERS’ MOTION FOR SUMMARY
JUDGMENT OF NONINFRINGEMENT OF THE 449 PATENT**

(“SIMULATING A VIRTUAL FILE SYSTEM”)

Papst Licensing GmbH & Co. KG, a German company, sues multiple manufacturers of digital cameras for alleged infringement of two patents owned by Papst: U.S. Patent Number 6,470,399 (399 Patent) and U.S. Patent Number 6,895,449 (449 Patent). The Camera Manufacturers¹ have moved for summary judgment of noninfringement with respect to the 449 Patent because the accused products do not meet the “simulating a virtual file system” claim limitation. The motion will be granted.

¹ This Multi District Litigation (MDL) currently consists of First and Second Wave Cases. The “First Wave Cases” are: *Fujifilm Corp. v. Papst*, 07-cv-1118; *Matsushita Elec. Indus. Co., Ltd. v. Papst*, 07-cv-1222; *Papst v. Olympus Corp.*, 07-cv-2086; *Papst v. Samsung Techwin Co.*, 07-cv-2088; *Hewlett-Packard Co. v. Papst*, 08-cv-865; and *Papst v. Nikon Corp.*, 08-cv-985. The “Second Wave Cases” currently are: *Papst v. Canon*, 08-cv-1406; *Papst v. Sanyo*, 09-cv-530. The Camera Manufacturers (CMs) seeking summary judgment here are parties in the First Wave Cases; they are: Fujifilm Corporation; Fujifilm U.S.A., Inc.; Fujifilm Japan; Panasonic Corporation (f/k/a as Matsushita Electric Industrial Co., Ltd.); Victor Company of Japan, Ltd.; Olympus Corporation; Olympus Imaging America Inc.; Samsung Techwin Co., Ltd.; Samsung Opto-Electronics America, Inc.; Panasonic Corporation of North America; JVC Company of America; Hewlett-Packard Company (HP); Nikon Corporation; and Nikon, Inc. Papst’s infringement contentions against HP have been stricken and discovery has been stayed.

I. FACTS²

A. The Invention

The invention at issue is a “Flexible Interface for Communication Between a Host and an Analog I/O Device Connected to the Interface Regardless of the Type of the I/O Device.” 399 Patent, Title; 449 Patent, Title. Michael Tasler invented and patented the “interface device” and later sold the Patents to Papst. The invention was never produced or used.

The “interface device” is designed to provide data transfer between a data transmit/receive device and a computer without the need for special software; this is accomplished by telling the computer that the interface device is a device already known to the computer (and for which the computer already has drivers, i.e., software), regardless of what kind of data transmit/receive device actually is attached to the interface device. 399 Patent, Abstract; 449 Patent, Abstract; *see also* 399 Patent 5:67 & 6:1-22; 449 Patent 4:66-67 & 5:1-22.³

The interface device according to the present invention therefore simulates, both in terms of hardware and software, the way in which a conventional input/output device functions, preferably that of a hard disk drive. As support for hard disks is implemented as standard in all commercially available host systems, the simulation of a hard disk, for example, can provide host device-independent use. The interface device according to the present invention therefore no longer communicates with the host device or computer by means of a specially designed driver but by means of a program which is present in the BIOS system (Basic Input/Output System) and is normally precisely matched to the specific computer system on which it is installed, or by means of a specific program for the multi-purpose interface.

² This motion is one of eight filed by the Camera Manufacturers. In the interest of timely disposition, the Court does not recite the full background and assumes familiarity with its prior rulings. *See, e.g.*, Modified Claims Construction Op. [Dkt. 336]; Sanctions Op. [Dkt. 429].

³ The Patents are cited by a column number, then a colon, then the line number.

399 Patent 5:5-20; 449 Patent 4:9-24 (same). By directing the computer to communicate using customary software already in the computer, the interface device fulfills its purpose—to provide “communication between a host device and a data transmit/receive device whose use is host device-independent and which delivers a high data transfer rate.” 399 Patent 3:24-27; 449 Patent 3:20-23 (same).

B. The 449 Patent and the “Virtual File System” Limitation

The immediate motion for summary judgment is based on the “simulating a virtual file system” claim limitation of the 449 Patent. The products that Papst accuses of infringement are digital cameras, camcorders, and voice recorders manufactured and/or sold by the Camera Manufacturers in the United States. Papst alleges that these accused products are “interface devices” that infringe the following Claims of the 449 Patent: independent Claims 1, 17, and 18 and dependent Claims 2, 6, 7, 8, 9, 12, 13, 15, and 16. All of these asserted Claims include the limitation “wherein the interface device is arranged for simulating a virtual file system to the host.”⁴ For example, Claim One of the 449 Patent provides:

What is claimed is:

1. An interface device for communication between a host device, which comprises drivers for input/output devices customary in a host device and a multi-purpose interface, and a data transmit/receive device comprising the following features:

a processor;

a memory;

a first connecting device for interfacing the host device with the interface device via the multi-purpose interface of the host device;
and

⁴ Dependent Claims 2, 6, 7, 8, 9, 12, 13, and 15 each incorporate, by reference, all of the limitations of Claim 1 and therefore include the “simulating a virtual file system” limitation.

a second connecting device for interfacing the interface device with the data transmit/receive device,

wherein the interface device is configured by the processor and the memory in such a way that the interface device, when receiving an inquiry from the host device as to the type of a device attached to the multi-purpose interface of the host device, sends a signal, regardless of the type of the data transmit/receive device attached to the second connecting device of the interface device, to the host device which signals to the host device that it is a storage device customary in a host device, whereupon the host device communicates with the interface device by means of the driver for the storage device customary in a host device, and

wherein the interface device is arranged for simulating a virtual file system to the host, the virtual file system including a directory structure.

449 Patent 11:45-67 & 12:1-6 (emphasis added). In other words, once the interface device signals that it is a customary storage device already known to the host computer, the computer communicates with the interface device using the driver, *i.e.*, software, for the customary storage device, and the interface device simulates a “virtual file system” to the computer. *Id.* 12:1-6.

The specification does not add much more detail regarding the simulation of a virtual file system; it merely describes the communication between the host computer and the interface device and explains that, in its preferred embodiment, the interface device signals to the computer that “a hard disk drive is attached” and the interface “simulates a hard disk with a root directory⁵ whose entries are ‘virtual’ files which can be created for the most varied functions.” *Id.* 4:66-67 & 5:1-15; *see id.* 4:9-13 (“The interface device according to the present invention therefore simulates, both in terms of hardware and software, the way in which a conventional input/output device functions, preferably that of a hard disk drive.”); *id.* 5:58-59 (“As described above, the interface device appears to the host device as a hard disk.”)

⁵ During claims construction, the parties agreed that a “root directory” is “a directory that is not in another directory.”

As relevant to the present motion, the invented interface device receives data from a data transmit/receive device and makes the data appear to the computer as an ordinary file stored on a storage device such as a hard drive. The specification explains that after receiving a “read file xy” message from the computer, the interface device begins to transfer data from the transmit/receive device to the computer:

The second command interpreter of the digital signal processor [within the interface device] now interprets the read command of the host processor as a data transfer command, by decoding whether “xy” denotes, for example, a “real-time input” file, a “configuration” file or an executable file, whereby the same *begins to transfer data* from the data transmit/receive device via the second connecting device to the first connecting device and via the line 11 to the host device.

See id. 5:59-67 (emphasis added). In the preferred embodiment of the invention, the interface device allows the computer to “read” a virtual “real time input” file:

Preferably, the volume of data to be acquired by a data transmit/receive device is specified in a configuration file described in the following [sic] by the user specifying in the said configuration file that a measurement is to last, for example, five minutes. To the host device the “real time input” file then appears as a file whose length corresponds to the anticipated volume of data in those five minutes. Those skilled in the art know that communication between a processor and a hard disk consists of the processor transferring to the hard disk the numbers of the blocks or clusters or sectors whose contents it wishes to read. By reference to the FAT [File Allocation Table] the processor knows which information is contained in which block. In this case, communication between the host device and the interface device according to the present invention therefore consists of the very fast transfer of block numbers and preferably of block number ranges because a virtual “real time input” file will not be fragmented. If the host device now wants to read the “real time input” file, it transfers a range of block numbers to the interface device, whereupon data commences to be received via the second connecting device and data commences to be sent to the host device via the first connecting device.

Id. 6:1-22.

In light of the language of the 449 Patent and the specification, the Court found that a “virtual file system” is:⁶

[O]ne that is “not physically existing as such but made by software to appear to do so.” Oxford English Dictionary at 674 (defining “virtual” in the context of computers) (attached to CMS’ *Markman* Br. as Ex. P); *accord* New IEEE Dictionary at 1461 (“virtual record” is a record that “appears to be but is not physically stored”) (attached to CMS’ *Markman* Br. as Ex. G).

Modified Claims Construction Op. [Dkt. 336] (Claims Constr. Op.) at 68. Thus, the Court defined the phrase “simulating a virtual file system” as used in the 449 Patent to mean “appearing to be a system of files, including a directory structure, that is *not physically stored*; rather, it is constructed or derived from existing data when its contents are requested by an application program so that it appears to exist as a system of files from the point of view of the host device.” *Id.* at 68-69 (emphasis added); *see also* Claims Construction Order [Dkt. 337] at 5. Likewise, the Court construed the term “virtual files” as “files that appear to be but are not physically stored; rather, they are constructed or derived from existing data when their contents are requested by an application program so that they appear to exist as files from the point of view of the host device.” Claims Constr. Op. at 67.⁷

⁶ Pursuant to *Markman v. Westview Instruments, Inc.*, 517 U.S. 370 (1996), a court is required to construe the contested claims of the patents before a jury can determine whether the accused products infringe. In claims construction, a court must interpret the words of each contested claim from the perspective of one skilled in the art at the time of invention, in light of the patent documents and the prosecution history. *Phillips v. AWH Corp.*, 415 F.3d 1303, 1313 (Fed. Cir. 2005).

⁷ The phrase “virtual file” is used in Claim Seven of the 399 Patent and does not appear in the 449 Patent. Because the Court construed the term “virtual file” immediately before, and consistently with, its construction of the phrase “virtual file system,” the Court’s construction of the term “virtual file” provides important context here.

C. Accused Products

The “Accused Products” are all of the digital cameras, camcorders, and voice recorders listed in the Final Infringement Contentions by make and model.⁸ *See generally* Final Infringement Contentions [Dkt. 416] (FICs) at 220-306 (Tables 12-14). All of the products accused of infringing the 449 Patent are Mass Storage Class (MSC) devices. *See* FICs at 261-286 (Table 13). MSC devices communicate using the “MSC” specification, which means that when an MSC device is connected to a computer and the computer inquires as to what type of device it is, the MSC device identifies itself as a mass storage class device such as a hard disk drive. *See* FICs 36-38.

It is uncontested that the Accused Products physically store actual files, such as image files, movie files, and/or audio files in standard file formats. *See* Mot. for Summ. J. Regarding 449 Patent (MSJ Re 449 Patent) [Dkt. 452], Decls. of CMs Representatives [Dkt. 452-5]⁹; FICs at 49 (the accused MSC devices “all store files in solid state memory”); Opp. at 10 (“All of the data that appears in the file system is stored in the memory chips as blocks of boot sequence, FAT, directory structure, and files data.”). The Accused Products store files in one or both of two types of non-volatile memory: (1) removable memory such as memory cards; and/or (2) non-removable, internal memory. Decls. of CMs Representatives [Dkt. 452-5].¹⁰ The files stored in the Accused Products’ non-volatile memory can be accessed and downloaded when the

⁸ Papst was not granted leave to add cell phones and MP3 players to this litigation. *See* Sanctions Op. [Dkt. 388] at 12.

⁹ *See* Declarations of CMs Representatives: Suzuki (Olympus) Decl. ¶ 4; Miura (Olympus) Decl. ¶ 4; Takashima (Panasonic) Decl. ¶ 4; Higaki (Panasonic) ¶ 4; Otsuka (JVC) Decl. ¶ 4; Lim (STW) Decl. ¶ 4; Tamayama (Fujifilm) Decl. ¶ 5. “STW” is Samsung Techwin Co., Ltd. and Samsung Opto-Electronics America, Inc., collectively.

¹⁰ *See* Suzuki (Olympus) Decl. ¶ 5; Miura (Olympus) Decl. ¶ 5; Takashima (Panasonic) Decl. ¶ 5; Higaki (Panasonic) ¶ 5; Otsuka (JVC) Decl. ¶ 5; Lim (STW) Decl. ¶ 5; Tamayama (Fujifilm) Decl. ¶ 6.

Accused Products are connected to a computer or when their memory cards are inserted into the memory card slot of a computer. *Id.*¹¹

Further, the Accused Products' non-volatile memory complies with the FAT (File Allocation Table) file system specification. *Id.*¹² Papst does not dispute that the Accused Products use a common FAT file system. *See* MSJ Re 449 Patent at 12; Opp'n at 5-6 [Dkt. 471]. FAT is a well-known and widely-used file system that originated in the late 1970s and early 1980s. *See* Reply [Dkt. 503], FAT Specification [Dkt. 452-2] at 1.

Arguing that the Accused Products store real physical files and do not simulate a "virtual file system," the Camera Manufacturers move for summary judgment of noninfringement of the 449 Patent. *See* MSJ Re 449 Patent [Dkt. 452]; Reply [Dkt. 503]. Papst opposes. *See* Opp'n [Dkt. 471].

II. LEGAL STANDARD

Under Rule 56 of the Federal Rules of Civil Procedure, summary judgment shall be granted "if the movant shows that there is no genuine dispute as to any material fact and the movant is entitled to judgment as a matter of law." Fed. R. Civ. P. 56(a); *accord Anderson v. Liberty Lobby, Inc.*, 477 U.S. 242, 247 (1986). On summary judgment, the burden on a moving party who does not bear the ultimate burden of proof in the case may be satisfied by making an initial showing that there is an absence of evidence to support the nonmoving party's case.

¹¹ *See* Suzuki (Olympus) Decl. ¶¶ 7, 9; Miura (Olympus) Decl. ¶¶ 7, 9; Takashima (Panasonic) Decl. ¶¶ 7, 9; Higaki (Panasonic) ¶¶ 7, 9; Otsuka (JVC) Decl. ¶¶ 7, 9; Lim (STW) Decl. ¶¶ 7, 9; Tamayama (Fujifilm) Decl. ¶¶ 8, 10.

¹² *See* Suzuki (Olympus) Decl. ¶ 11; Miura (Olympus) Decl. ¶ 11; Takashima (Panasonic) Decl. ¶ 11; Higaki (Panasonic) ¶ 11; Otsuka (JVC) Decl. ¶ 11; Lim (STW) Decl. ¶ 11; Tamayama (Fujifilm) Decl. ¶ 12. The FAT system is governed by a specification produced by the Microsoft Corporation called the "Microsoft Extensible Firmware Initiative: FAT32 File System Specification."

Celotex Corp. v. Catrett, 477 U.S. 317, 325 (1986). This burden “may be discharged by ‘showing’—that is, pointing out to the district court—that there is an absence of evidence to support the nonmoving party’s case.” *Id.*

The burden then shifts to the nonmovant to demonstrate the existence of a genuine issue of material fact. The nonmovant may not rest on mere allegations or denials, but must instead by affidavit or otherwise, present specific facts showing that there is a genuine issue for trial. *See* Fed. R. Civ. P. 56(c); *Celotex*, 477 U.S. at 324; *see also Greene v. Dalton*, 164 F.3d 671, 675 (D.C. Cir. 1999) (nonmovant must present specific facts that would enable a reasonable jury to find in its favor).

In ruling on a motion for summary judgment, the court must draw all justifiable inferences in the nonmoving party’s favor. *Anderson*, 477 U.S. at 255. A nonmoving party, however, must establish more than “[t]he mere existence of a scintilla of evidence” in support of its position. *Id.* at 252. In addition, if the evidence “is merely colorable, or is not significantly probative, summary judgment may be granted.” *Anderson*, 477 U.S. at 249-50 (citations omitted). Summary judgment is properly granted against a party who “after adequate time for discovery and upon motion . . . fails to make a showing sufficient to establish the existence of an element essential to that party’s case, and on which that party will bear the burden of proof at trial.” *Celotex*, 477 U.S. at 322.

Summary judgment can be granted in a patent case if there is no dispute over the structure of the accused products, at which point the question of infringement “collapses” into the question of claim construction and may be resolved by the court. *Desper Prods., Inc. v. QSound Labs, Inc.*, 157 F.3d 1325, 1332-33 (Fed. Cir. 1998). The burden of proving infringement rests on the patent holder. *Welker Bearing Co. v. PHD, Inc.*, 550 F.3d 1090, 1095

(Fed. Cir. 2008). Thus, on summary judgment the Camera Manufacturers bear the burden of making an initial showing that there is an absence of evidence to support Papst's claim of infringement, and Papst bears the burden of presenting specific facts showing that there is a genuine dispute of material fact for trial.

III. ANALYSIS

A. Literal Infringement and the Doctrine of Equivalents

To determine whether a patent has been infringed, a court must (1) construe the patent and (2) compare the devices accused of infringing to the construed patent claims. *Mars, Inc. v. H.J. Heinz Co., LP*, 377 F.3d 1369, 1373 (Fed. Cir. 2004). The party alleging infringement bears the burden of proof. *Jazz Photo Corp. v. Int'l Trade Comm'n*, 264 F.3d 1094, 1102 (Fed. Cir. 2001). Since this Court already has interpreted the Patents, the Court now proceeds to step two, a comparison of the accused cameras to the allegedly infringed Claims.

Patent infringement can be either (1) literal infringement or (2) infringement under the doctrine of equivalents. To prove literal infringement, a patentee must prove that the accused product satisfies each and every limitation of a claim. *Warner-Jenkinson Co. v. Hilton-Davis Chem. Co.*, 520 U.S. 17, 29 (1997); *Rohm & Haas v. Brotech Corp.*, 127 F.3d 1089, 1092 (Fed. Cir. 1997). A patent is literally infringed "when each of the claim limitations reads on, or in other words is found in, the accused device." *Allen Eng'g Corp. v. Bartell Indus., Inc.*, 299 F.3d 1336, 1345 (Fed. Cir. 2002). That is, if even a single claim limitation is absent in the accused device, there is no infringement. *Phonometrics, Inc. v. N. Telecom Inc.*, 133 F.3d 1459, 1467 (Fed. Cir. 1998). If a device does not infringe an independent claim of a patent, the device

cannot infringe a claim dependent on that independent claim.¹³ *Wahpeton Canvas Co., Inc. v. Frontier, Inc.*, 870 F.2d 1546, 1552 n.9 (Fed. Cir. 1989).

Alternatively, a plaintiff can show infringement under the doctrine of equivalents. The essential inquiry in determining whether there has been infringement under this doctrine is whether “the accused product or process contains elements identical or equivalent to each claimed element of the patented invention.” *Am. Calcar, Inc. v. Am. Honda Motor Co.*, 651 F.3d 1318, 1338 (Fed. Cir. 2011) (quoting *Warner-Jenkinson*, 520 U.S. at 40). A patentee alleging infringement under the doctrine of equivalents must submit particularized evidence of equivalence and must explain specifically why the difference between what the claims literally require and what the accused products actually do is “insubstantial.” *Am. Calcar*, 651 F.3d at 1338.

With respect to the present the “virtual file system” limitation, Papst’s Final Infringement Contentions allege actual infringement and do not allege infringement pursuant to the doctrine of equivalents.

B. Comparison of the Accused Products to the “Simulating a Virtual File System” Limitation

The premise of the 449 Patent is that the interface device responds to an inquiry from the host computer by signaling that the interface device is a customary storage device (preferably a hard disk drive) from which the computer can read data using the same software that the computer would use to read a hard disk drive. *See, e.g.*, 449 Patent 4:9-24, 5:58-59.

The interface device connects to a data transmit/receive device (where the data to be read originates) and separately connects to the host computer. 449 Patent, FIGS. 1&2; 4:48-49, 55-58

¹³ A claim in “dependent form” incorporates all the limitations of the claim on which it depends and adds something new, giving it a narrower scope than the claim on which it depends. *See* 35 U.S.C. § 112; *Phillips*, 415 F.3d at 1315.

(interface device connected to host device at one end by host line 11 and to data transmit/receive device at other end by output line 16). The interface device “fools” the host computer into accepting it as a customary device for which the computer already has drivers. *See* 449 Patent 4:9-24. The purpose of the interface device is to allow data transfer between numerous kinds of data transmit/receive devices and a computer without the need for separate drivers in the computer for each kind of data transmit/receive device. *Id.*; 449 Patent 3:20-23. Thus, the invention is exactly as it is titled: an *interface* for communication between a source of data, a data transmit/receive device, and a computer. 449 Patent, Title & Abstract.

The “files” that the host computer reads are not physically stored on the interface device. Rather, the interface device “simulates a virtual file system” that appears to show data, originating from the data transmit/receive device, in a format known to, and easily read by, the computer. *See* 449 Patent 6:1-22 & 12:4-5. A “virtual file” is “not physically stored” but is “constructed or derived from existing data” when its contents are requested so that it appears to the computer to be a physical file. Claims Constr. Op. at 68-69. A virtual file system does not actually exist, but software creates it in way that makes it appear to exist. *Id.* at 68. The software on the interface device makes the host computer believe that a customary data file is present when, in fact, there is no such file.

In contrast, the Accused Products have memory cards and internal memory that physically store real files in real file systems. Digital cameras, camcorders, and voice recorders physically store photographs, movies, and sound files. For example, when a user wants to see a photograph, he can connect his digital camera to a computer or insert the camera’s removable memory card into the computer’s memory card slot to view or download the image file as often as he wants, each time viewing/downloading the very same physical file. The files actually

exist; they are real and not virtual. Papst admits the critical fact—that the Accused Products physically store files. FICs at 49 (the accused MSC devices “all store files in solid state memory”); *see also* Opp. at 10 (“All of the data that appears in the file system is stored in the memory chips as blocks of boot sequence, FAT, directory structure, and files data.”); *id.* at 9 (“ . . . the FAT, directory structure, and files are physically stored on memory chips”); *id.* at 12 (“All the data that appears in the files is stored in the memory chips as blocks of file data.”); *id.* at 8 (“[T]he file system that appears to the host computer must be assembled from the blocks of FAT, directory structure, and file data stored in the memory chips”); *id.* at 7 (referring to “blocks of FAT, directory structure and file data stored in the memory chips”).

These admissions are fatal to Papst’s opposition here. Because the Accused Products physically store real files and the invention simulates virtual files on a virtual file system, the Accused Products do not literally infringe the 449 Patent.

C. Papst’s Request for Reconsideration

Although conceding that the Accused Product all store physical files, Papst does not concede that they do not infringe the 449 Patent. Papst’s Final Infringement Contentions object to the Court’s construction of “virtual files” and “virtual file system.” Ignoring the Court’s *Markman* opinion, Papst asserts first that virtual files “should be construed to mean files which appear to be present on an emulated disk drive, yet which are not actually on a rotating magnetic disk. There is nothing in the use of the word ‘virtual’ to preclude a real, stored file underlying the virtual representation of the file.” *Id.* at 49. Second, Papst asserts that a “‘virtual file system’ may include an actual file system under a layer of abstraction.” *Id.* at 50. Papst made, and lost, this argument during claims construction. Explaining that what is stored on the interface device is software that directs the interface device to present data *as if* it were in real

files, the Court held that “virtual files” and “virtual file systems” are “not physically stored; rather, they are constructed or derived from existing data when their contents are requested by an application program” Claims Constr. Op. at 67 (defining “virtual files”); *id.* at 68 (defining “virtual file system”).

Repeating its argument here, Papst essentially seeks reconsideration of claims construction. It fails to meet the standard for reconsideration. *See Singh v. George Wash. Univ.*, 383 F. Supp. 2d 99, 101 (D.D.C. 2005) (reconsideration may be permitted when a court has patently misunderstood a party, has made a decision outside the adversarial issues presented to the court by the parties, has made an error not of reasoning but of apprehension, or where a controlling or significant change in the law or facts has occurred since the submission of the issue to the court.) The request for reconsideration will be denied.

D. Papst’s New Theory of Infringement

Under the ruse that it is merely interpreting the Court’s claims construction, Papst presents a new theory of infringement in opposition to the Camera Manufacturers’ motion. *See, e.g.,* Opp’n at 8-14, 21-22. Papst is barred from arguing this new theory as it ignores the Court’s Claims Construction Opinion and Sanction Order (discussed below). Further, its arguments are erroneous.

Papst argues that the Accused Products infringe the “simulating a virtual file system” limitation because the system of files that appears to the host computer is “organized differently” than the manner in which data is physically stored. Papst explains its new theory at great length:

[T]he system of files that appears to the host computer in the MSC Accused Products is “not physically stored” because *the physical address for the data of the files and system of files that appear to the host computer must be constructed for each of the blocks of*

FAT, directory structure, and file data that are stored in a scattered fashion in the memory chips. The host computer can only request blocks of FAT, directory structure and file data stored in the memory chips using their logical block addresses [LBAs]. In order for the host computer to determine which blocks of data correspond to any particular file, the host computer attached to the MSC Accused Products must first obtain the blocks of FAT and directory structure data from the memory chips using LBAs, which are then translated in the interface device into the physical memory addresses of the memory chips, where the blocks of data corresponding to the FAT and directory structure are stored. The host computer must then determine the LBAs for the blocks of data that correspond to a particular file and request blocks of data corresponding to those LBAs to be sent to the computer. The MSC Accused Products then translate the LBAs to physical memory addresses where the blocks of file data are stored in the memory chips. The translation of LBAs to physical addresses occurs in the MSC Accused Products, independently of the attached host computer.

Opp'n at 6-7 (emphases added) (citing Papst's Notice of Filing Documents [Dkt. 475], Third Locke Decl. [Dkt. 475-1] ¶¶ 231-58). The main points, according to Papst's current arguments, are that: (1) files on the Accused Products "are not physically stored in the same form in which they appear to the host, because the blocks of data that make up the file system and files are stored in a scattered fashion on the memory chips," *id.* at 11, and (2) the process is "virtual" because it "translat[es] the logical block addresses from the host device into physical addresses of the solid-state memory," *id.* at 15 (citing Third Locke Decl. ¶ 315g(5) & (6)).

Papst's new definition of a "virtual file system" is so broad that it would include most, if not all, standard file systems. As Papst acknowledges, the Accused Products use a FAT file system. Opp. at 6. FAT was introduced by Microsoft in the 1970s and was first used in the Microsoft MS-DOS operating system. *See* FAT Specification [Dkt. 452-2]. In the world of computing, it has existed almost since the beginning of time. FAT is now one of the most widely-used file systems in the world. Reply at 6-7. The FAT file system organizes data by storing it in "logical sectors," called "logical block addresses," which the FAT driver translates

into physical locations for retrieval when data is requested. *Id.* Papst argues that the process of translating logical block addresses into physical addresses where data is stored in real memory constitutes a virtual file system because data is “scattered” in a FAT file system and yet presented upon request in a different fashion. Opp. at 5 (“The data from the memory chips, once located, can then be sent to the host computer, which would ‘view’ the scattered data as files or systems of files whose data is organized differently than how the data is stored in memory chips.”) The use of logical sectors to locate an electronic physical address does not create a “virtual” file system, as Papst would have it. Despite Papst’s best efforts to confuse, the Accused Products store data in real files that are not at all virtual. Papst’s interpretation of “virtual file system” would render the term meaningless because it would subsume most real *and* virtual file systems, including those long established before Mr. Tasler’s invention. *See Modine Mfg. Co. v. U.S. Int’l Trade Comm’n*, 75 F.3d 1545, 1557 (Fed. Cir. 1996), (“When claims are amenable to more than one construction, they should when reasonably possible be interpreted so as to preserve their validity”).

Papst’s remaining arguments are not worthy of long discussion. Papst asserts that “the Court acknowledged that the data making up the file system would be present, but would be stored in a different way than what the host sees.” Opp’n at 21. Papst relies on the Court’s use of the phrase “as such”: the Court defined “virtual file system” to be a file system that is “not physically existing *as such* but made by software to appear to do so.” Papst contends that the phrase “as such” means that the data that make up a virtual file *is* physically stored, but it is just stored in a different way than what the host computer can see. *Id.* (citing Claims Constr. Op. at 68 (emphasis added)). The words “as such” do not undermine the clear message of the Claims Construction Opinion: “virtual file system” and “virtual files” are “not physically existing” and “not physically stored.” Claims Constr. Op. at 66-68.

In the same vein, Papst argues that, while a virtual file system is not physically stored, underlying “existing data” may be physically stored. Opp’n at 1. The point is accurate but irrelevant. The Court’s definition of virtual file system refers to “existing data” as follows— “appearing to be a system of files . . . that is not physically stored; rather, it is constructed or derived from existing data when its contents are requested” Claims Constr. Op. at 68. Papst over reads the term “existing data” to refer to data that is physically stored on the interface device. As is clear from the 449 Patent and its specification, *see* 449 Patent 1:35-48, the data transmit/receive device might store, generate, and/or stream data (“existing data”) that the interface device then presents as a virtual file to the host computer so that it can be read.

Finally, Papst argues that the definition of “virtual file system” should be the same as the definition of “virtual memory,” which “does not mean that something does not exist at all. Rather, it exists but in a form different from the observed form.” Opp. at 22. In essence, this is another request for reconsideration of the Claims Construction Opinion and, for the reasons outlined above, the Court again denies it. In any event, the definition of “virtual memory” is inapposite. As Papst explains it, the concept of “virtual memory” is that “external data storage that actually exists is made to look like internal computer memory that actually exists.” Opp’n at 22. Papst reasons, that “in this specific example, ‘virtual’ does not mean that something does not exist at all. Rather, it exists but in a form difference from the observed form.” *Id.* “Virtual memory” is a separate and distinct concept from that of “virtual file system.” As discussed above, a “virtual file system” is a software construct used to present data when a “file” is requested.

E. Papst is Barred from Modifying Its Final Infringement Contentions

Papst is precluded from asserting any new theories of infringement pursuant to a sanction. To understand how Papst came to be sanctioned, some history is needed.

Papst had filed imprecise infringement contentions before the Court construed the Patents. *See* Infringement Contentions [Dkt. 110]. After claims construction, the Court ordered Papst to file final revised infringement contentions that (1) would conform to the Court's interpretation of the Patents as set forth in the Claims Construction Opinion and Order and (2) would enable the parties to engage in focused discovery.

The need for final contentions from Papst became evident at a discovery status conference in August 2010, three years into the litigation. Papst had submitted extraordinarily broad discovery to the Camera Manufacturers, and the Court ordered Papst to redefine its asserted claims and infringement contentions in light of the claims construction opinion so that discovery could be more focused, as previously ordered:

I said focused discovery and what I got was a shotgun shell. I mean, everything. I do not consider that focused and I don't think that it fulfills my obligation to get this done quickly and with the least expense possible under the circumstances. So what I think we need to start with is the concept that Papst filed infringement contentions . . . and hasn't changed them, hasn't indicated it wants to change them, hasn't indicated it plans or needs to change them but now says [it] need[s] a ton of discovery. I'm not sure that all of your contentions can stand in light of the claims construction decision which I appreciate you don't like, it's okay. But nobody knows what they're fighting about now. Nobody can tell and you don't want to tell them, and we're not going to do it that way. I mean, you're the plaintiff. You have allegations, you need to say what they are. So the first thing is I'm going to direct Papst to refile its claims contentions, its infringement contentions. . . . File that, then we'll know what we're arguing about. Only then can we figure out what discovery is really needed.

See Mot. for Sanctions [Dkt. 388], Ex. A (Tr. of Aug. 31, 2010 Hearing) at 18-19.

The Court further directed, “[Y]ou have got to bring your infringement contentions up to date. People have to know what they're litigating about. And only when you do can you then say okay, this is the discovery we need for these reasons.” *Id.* at 32. The Court told Papst that its asserted claims and infringement contentions needed to be clear cut:

First you have to decide what your infringement contentions are. Only when you know what, what camera you're asserting [infringes] what claim and for what reason[,] can you possibly figure out what discovery you might need that you don't already have.

Id. at 33-34.

As a result of the status conference, the Court issued its Sixth Practice and Procedure Order (PPO) requiring Papst to file final contentions with specificity as to each alleged infringer, each alleged infringing product, and each Patent Claim allegedly infringed.

The Sixth PPO provided:

2. No later than October 13, 2010, Papst shall file its Final Disclosure of Asserted Claims and Infringement Contentions. Separately for each opposing party, this Final Disclosure shall contain the following information:

a. Each claim of each patent in suit that is allegedly infringed by each opposing party, including for each claim the applicable statutory subsections of 35 U.S.C. § 271 asserted;

b. Separately for each asserted claim, each accused apparatus, product, device, process, method, act or other instrumentality ("Accused Instrumentality") of each opposing party of which Papst is aware. This identification shall be as specific as possible. Each product, device, and apparatus shall be identified by name or model number, if known. Each method or process shall be identified by name, if known or by any product, device or apparatus which, when used, allegedly results in the practice of the claimed method or process;

c. *A chart identifying specifically where each limitation of each asserted claim is found within each Accused Instrumentality, including for each limitation that such party contends is governed by 35 U.S.C. § 112(6), the identity of the structure(s), act(s), or material(s) in the Accused Instrumentality that performs the claimed function.*

d. For each claim which is alleged to have been indirectly infringed, an identification of any direct infringement and a description of the acts of the alleged indirect infringer that contribute to or are inducing that direct infringement. Insofar as

alleged direct infringement is based on joint acts of multiple parties, the role of each such party in the direct infringement must be described;

e. Whether each limitation of each asserted claim is alleged to be literally present or present under the doctrine of equivalents in the Accused Instrumentality; and

f. For any patent that claims priority to an earlier application, the priority date to which each asserted claim allegedly is entitled.

Sixth PPO [Dkt. 372] ¶ 2 (adopting provisions of Rule 3-1 (N.D. Cal. Patent Local Rules))

(emphasis added).

The Sixth PPO adopted the requirements set forth in Northern District of California Patent Rule 3-1 because that Rule was designed to “make the parties more efficient, to streamline the litigation process, and to articulate with specificity the claims and theory of a plaintiff’s infringement claims.” *Bender v. Micrel Inc.*, Civ. No. 09-1144, 2010 WL 520513, at *2 (N.D. Cal. Feb. 6, 2010). Rule 3-1 was intended to prevent cases from “stagger[ing] for months without clear direction” by “focusing discovery on building precise final infringement or invalidity contentions and narrowing issues for *Markman*, summary judgment trial, and beyond.” *Connectel, LLC v. Cisco Sys., Inc.*, 391 F. Supp. 2d 526, 527 (E.D. Tex. 2005). Via the language of Rule 3-1, this Court required Papst to “crystallize its theory of the case and patent claims.”¹⁴ *See InterTrust Tech. Corp. v. Microsoft Corp.*, Civ. No. 01-1640, 2003 WL 23120174, at *3 (N.D. Cal. Dec. 1, 2003) (characterizing Rule 3-1). In sum, the Court ordered Papst to file contentions that comported with the Court’s claims constructions and that were *sufficiently precise and detailed for the purpose of streamlining this already protracted litigation.*

¹⁴ A plaintiff in the Northern District of California is expected to articulate its infringement contentions no later than 14 days after the initial case management conference, a much earlier stage than was required in this MDL. N.D. Cal. Patent Rule 3-1. Papst was required to crystallize its theories only after claims construction.

Papst filed Final Infringement Contentions,¹⁵ but many contentions remained vague and uninformative. Through its experienced patent lawyers, Papst blatantly disregarded the Sixth PPO. The Court took Papst to task for obfuscating its infringement theories, finding that Papst had done so intentionally as part of its strategy to extend this litigation excessively, since Papst's business *is* litigation. Sanctions Op. [Dkt. 429] at 7-8. In addition to concealing its infringement theories, Papst purposely disregarded the Modified Claims Construction Opinion and Order. The Sanctions Opinion explained:

[T]he Final [Infringement] Contentions additionally lack the requisite specificity because they repeatedly reiterate Papst's version of previously rejected claims constructions and then advance theories based on such rejected constructions. *See, e.g.*, [FICs] at 33 (asserting that "second connecting device" means a device for interfacing and not "a physical plug or socket for permitting a user readily to attach and detach . . ." as construed by the Court). In this same vein, Papst also attempts to incorporate and reassert its original contentions filed May 28, 2008, before claims construction. *Id.* at 2. Such an approach bespeaks a total lack of respect for Court orders and the timely resolution of this case, but it is consistent with Papst's approach from the beginning.¹⁶

Id. at 10. Papst's failure to detail its infringement claims properly was not an innocent error; it was part of a calculated strategy.

For this astounding and brash failure to follow direct court orders, the Court imposed a reasonable sanction against Papst—requiring Papst "to live with its Final [Infringement] Contentions as they stand without further modification." Sanctions Op. at 7. The

¹⁵ Papst filed the infringement contentions on October 13, 2010, Dkt. 379, and filed revised infringement contentions on January 21, 2011, Dkt. 416. It is the revised contentions that the Court refers to as Papst's "Final Infringement Contentions."

¹⁶ *See, e.g.*, Mem. Op. [Dkt. 82] (sanctioning Papst for failure to comply with a direct discovery order), *modified in part by* Mem. Op. [Dkt. 123]. Papst's petition for writ of mandamus, *see* Dkt. 167, was denied by the Federal Circuit. *In re Papst Licensing GmbH & Co. KG*, Misc. No. 877, 314 F. App'x 295 (Fed. Cir. 2008).

Court barred Papst from modifying the Final Infringement Contentions and barred Papst from advancing any arguments for infringement (or against claims of noninfringement) that either (1) are not based solely on this Court’s constructions of the Patents or (2) are not already set forth specifically and explicitly in the Final Infringement Contentions. *See* Sanctions Order [Dkt. 430] 2.

In sum, pursuant to the Sanctions Opinion and Order, Papst’s Final Infringement Contentions are just that—final. “[T]hey stand without further modification.” Sanctions Op. at 7. To permit amendment of the Final Infringement Contentions to set forth a new theory of infringement regarding the “simulating a virtual file system” limitation in opposition to a motion for summary judgment would negate the sanction and allow repeated and total disregard of this Court’s orders.

Papst pretends that its theory is “consistent with” a theory presented in the Final Infringement Contentions and legitimate because Final Infringement Contentions are only required to give notice, not to present a prima facie case. Opp’n at 23. The Court specifically ordered that Papst’s Final Infringement Contentions could not be modified further. Papst’s argument is without merit and is rejected. In no way did the Final Infringement Contentions provide notice of Papst’s current infringement theory.

Having made no arguments that meet the construction of the Patents in the Claims Construction Opinion, Papst cannot demonstrate the existence of a genuine issue of material fact with regard to infringement, *Celotex*, 477 U.S. at 324, nor present specific facts that would enable a reasonable jury to find in its favor. *See Greene*, 164 F.3d at 675. Accordingly, summary judgment will be granted to the Camera Manufacturers. The Accused Products do not literally infringe the 449 Patent.

F. Additional Discovery

At one point, Papst moved for more discovery on a “virtual file system,” *see* Mot. for Rule 56(d) Discovery [Dkt. 479], but later withdrew that portion of its motion regarding the “virtual file system” claim limitation. *See* Reply in Support of Mot. for Rule 56(d) Discovery [Dkt. 515] at 1. The request for more discovery regarding the “simulating a virtual file system” limitation will be denied as moot.

IV. CONCLUSION

The Camera Manufacturers’ motion for summary judgment with respect to the “simulating a virtual file system” limitation in the 449 Patent [Dkt. 452] will be granted.¹⁷ A memorializing Order accompanies this Opinion.

Date: October 4, 2013

/s/
ROSEMARY M. COLLYER
United States District Judge

¹⁷ As it has automatically on every motion for summary judgment, Papst moved to file a surreply. *See* Mot. for Leave to File Surreply [Dkt. 512]. Because the Camera Manufacturers’ Reply [Dkt. 503] did not raise new issues and surreplies are disfavored in this District, Papst’s motion will be denied. *See Crummey v. Social Sec. Admin.*, 794 F. Supp. 2d 46, 62 (D.D.C. 2011).

UNITED STATES DISTRICT COURT
FOR THE DISTRICT OF COLUMBIA

<hr/>	
IN RE PAPST LICENSING GMBH & CO. KG)
LITIGATION)
)
This document relates to)
)
ALL CASES)
)
)
)
)
<hr/>)

Misc. Action No. 07-493 (RMC)

MDL No. 1880

**OPINION RE: CAMERA MANUFACTURERS’ MOTION FOR SUMMARY
JUDGMENT ON “SECOND CONNECTING DEVICE”**

Papst Licensing GmbH & Co. KG, a German company, sues multiple manufacturers of digital cameras for alleged infringement of two patents owned by Papst: the U.S. Patent Number 6,470,399 (399 Patent) and U.S. Patent Number 6,895,449 (449 Patent). The Camera Manufacturers¹ have moved for summary judgment of noninfringement of the 399

¹ This Multi District Litigation (MDL) currently consists of First and Second Wave Cases. The “First Wave Cases” are: *Fujifilm Corp. v. Papst*, 07-cv-1118; *Matsushita Elec. Indus. Co., Ltd. v. Papst*, 07-cv-1222; *Papst v. Olympus Corp.*, 07-cv-2086; *Papst v. Samsung Techwin Co.*, 07-cv-2088; *Hewlett-Packard Co. v. Papst*, 08-cv-865; and *Papst v. Nikon Corp.*, 08-cv-985. The “Second Wave Cases” currently are: *Papst v. Canon*, 08-cv-1406; and *Papst v. Sanyo*, 09-cv-530. The Camera Manufacturers (CMs) seeking summary judgment here are parties in the First Wave Cases; they are: Fujifilm Corporation; Fujifilm U.S.A., Inc.; Fujifilm Japan; Panasonic Corporation (f/k/a as Matsushita Electric Industrial Co., Ltd.); Victor Company of Japan, Ltd.; Olympus Corporation; Olympus Imaging America Inc.; Samsung Techwin Co., Ltd.; Samsung Opto-Electronics America, Inc.; Panasonic Corporation of North America; JVC Company of America; Hewlett-Packard Company (HP); Nikon Corporation; and Nikon, Inc.

and 449 Patents with regard to “second connecting device” claim limitation.² The motion will be denied without prejudice.

The Camera Manufacturers assert that many of the devices accused of infringement do not meet the “second connecting device” limitation of the 399 or 449 Patents.³ *See* Mot. for Summ. J. Re Second Connecting Device [Dkt. 450]; Reply [Dkt. 502]. Papst opposes.⁴ *See* Opp’n [Dkt. 478]. It is not necessary for the Court to address the arguments presented by the parties because, due to the combined effect of the Court’s rulings on motions for summary judgment filed by First Wave Camera Manufacturers, *all* products accused of infringement that were manufactured by First Wave Camera Manufacturers have been held not to infringe. *See* Papst Reply in Support of its Mot. to Withdraw [Dkt. 543] at 3; Op. Re Samsung MSJ [Dkt. 520]; Order Re Samsung MSJ [Dkt. 521]; Op. Re CM MSJ Re Memory Cards [Dkt. 524]; Order Re CM MSJ Re Memory Cards [Dkt. 525]; Op. Re CM MSJ Re Data

² This motion is one of eight filed by the Camera Manufacturers. In the interest of timely disposition, the Court does not recite the full background and assumes familiarity with its prior rulings. *See, e.g.*, Claims Constr. Op. [Dkt. 336]; Sanctions Op. [Dkt. 429].

³ The Court construed “second connecting device” in the 399 Patent to mean “a physical plug or socket for permitting a user readily to attach and detach the interface device with a plurality of dissimilar data transmit/receive devices, including a sampling circuit for sampling the analog data provided by the data transmit/receive device and an analog-to-digital converter for converting data sampled by the sampling circuit into digital data,” and in the 449 Patent to mean “a physical plug or socket for permitting a user readily to attach and detach the interface device with a plurality of dissimilar data transmit/receive devices.” *See* Claims Constr. Op. [Dkt. 336] at 40.

⁴ Papst agrees, however, that some products do not infringe the 399 Patent because they do not meet the “analog data” requirement. *See* Opp’n [Dkt. 478] at 2 (“[A]ccessories which in fact produce signals that are digital only would not by themselves lead to infringement of the 399 patent”); *id.* at 4 (“Papst agrees that if in fact an accused product does not receive analog data from any external accessory, then it does not infringe the 399 patent under the Court’s claims construction.”); *id.* at 15 (“cameras that receive only digital data from the [data transmit/receive devices] do not infringe the 399 Patent”); *see also* Opp’n to HP’s Mot. Summ. J. [Dkt. 470] at 25 (accused cameras that receive digital data, and not analog data, from memory cards and USB connectors do not infringe the 399 Patent).

Transmit/Receive Device Claim Limitation [Dkt. 528]; Order Re CM MSJ Re Data
Transmit/Receive Device Claim Limitation [Dkt. 529]; Op. Re CM MSJ Re Input/Output Device
Customary In a Host Device [Dkt. 534]; Order Re CM MSJ Re Input/Output Device Customary
In a Host Device [Dkt. 535]; Op. Re CM MSJ Re Table 15 Devices [Dkt. 536]; Order Re CM
MSJ Re Table 15 Devices [Dkt. 537] Op. Re CM MSJ Re Simulating a Virtual File System [Dkt.
545]; Order Re CM MSJ Re Simulating a Virtual File System [546]; Op. Re HP MSJ [Dkt. 547];
Order Re HP MSJ [Dkt. 548].

Accordingly, the Camera Manufacturers’ motion for summary judgment of
noninfringement regarding the “second connecting device” claim limitation [Dkt. 450] will be
denied without prejudice. Because the Court denies the motion at issue here without prejudice,
the portion of Papst’s motion for additional discovery [Dkt. 479] regarding the “second
connecting device” claim limitation will be denied without prejudice.⁵ Papst’s motion for leave
to file a surreply regarding “second connecting device” [Dkt. 517] will be denied.⁶ A
memorializing Order accompanies this Memorandum Opinion.

Date: October 23, 2013

/s/
ROSEMARY M. COLLYER
United States District Judge

⁵ Because Papst’s motion for additional discovery [Dkt. 479] was addressed in each of the
summary judgment rulings cited in this Opinion, the motion now has been adjudicated in full.

⁶ Papst moved to file a surreply, as it has with every motion for summary judgment. *See* Mot. for
Leave to File Surreply [Dkt. 517]. Because the Camera Manufacturers’ reply brief did not raise
new issues and because surreplies are disfavored in this district, the motion to file a surreply will
be denied. *See Crummey v. Social Sec. Admin.*, 794 F. Supp. 2d 46, 62 (D.D.C. 2011).



US006470399B1

(12) **United States Patent**
Tasler

(10) **Patent No.:** **US 6,470,399 B1**
 (45) **Date of Patent:** **Oct. 22, 2002**

(54) **FLEXIBLE INTERFACE FOR COMMUNICATION BETWEEN A HOST AND AN ANALOG I/O DEVICE CONNECTED TO THE INTERFACE REGARDLESS THE TYPE OF THE I/O DEVICE**

(75) Inventor: **Michael Tasler, Würzburg (DE)**

(73) Assignee: **Labortechnik Tasler GmbH, Würzburg (DE)**

(*) Notice: Subject to any disclaimer, the term of this patent is extended or adjusted under 35 U.S.C. 154(b) by 0 days.

(21) Appl. No.: **09/331,002**

(22) PCT Filed: **Mar. 3, 1998**

(86) PCT No.: **PCT/EP98/01187**

§ 371 (c)(1),
 (2), (4) Date: **Jun. 14, 1999**

(87) PCT Pub. No.: **WO98/39710**

PCT Pub. Date: **Sep. 11, 1998**

(30) **Foreign Application Priority Data**

Mar. 4, 1997 (DE) 197 08 755

(51) **Int. Cl.**⁷ **G06F 13/14**

(52) **U.S. Cl.** **710/16; 710/62; 710/63**

(58) **Field of Search** **710/15, 16, 11, 710/12, 62, 63, 64; 703/23, 24, 25**

(56) **References Cited**

U.S. PATENT DOCUMENTS

5,291,611 A	3/1994	Davis et al.	
5,297,124 A *	3/1994	Plotkin et al.	703/25
5,430,855 A *	7/1995	Walsh et al.	703/23
5,444,644 A	8/1995	Divjak	
5,487,154 A	1/1996	Gunji	
5,499,378 A *	3/1996	McNeill et al.	703/24
5,506,692 A	4/1996	Murata	
5,510,774 A	4/1996	Loncle	
5,548,783 A *	8/1996	Jones et al.	710/15
6,012,113 A *	1/2000	Tuckner	710/64

FOREIGN PATENT DOCUMENTS

DE	195 28 889 A1	2/1997
EP	0 436 458 A2	7/1991
EP	0 685 799 A1	12/1995
JP	06301607 A	10/1994
JP	08110883 A	4/1996
WO	WO94/19746	9/1994

OTHER PUBLICATIONS

Steve Martin, "PC-based Data Acquisition in an Industrial Environment," pp. 1-3 (1990).
 Payne et al., "High Speed PC-based Data Acquisition Systems," IEEE, pp. 2140-2145 (1995).
 National Instruments Corporation, "Dynamic Signal Acquisition and DSP Board for the PC AT," IEEE 488 and VXIbus Control, Data Acquisition, and Analysis, pp. 3-118-3-123, (1994).
 IBM Corporation, "Communication Method between Devices through FDD Interface," IBM Technical Disclosure Bulletin, vol. 38 (No. 05), p. 245 (May, 1995).

* cited by examiner

Primary Examiner—Thomas Lee

Assistant Examiner—Thuan Du

(74) *Attorney, Agent, or Firm*—Patton Boggs LLP

(57) **ABSTRACT**

An interface device (10) provides fast data communication between a host device with input/output interfaces and a data transmit/receive device, wherein the interface device (10) comprises a processor means (13), a memory means (14), a first connecting device (12) for interfacing the host device with the interface device, and a second connecting device (15) for interfacing the interface device (10) with the data transmit/receive device. The interface device (10) is configured by the processor means (13) and the memory means (14) in such a way that, when receiving an inquiry from the host device via the first connecting device (12) as to the type of a device attached to the host device, regardless of the type of the data transmit/receive device, the interface device sends a signal to the host device via the first connecting device (12) which signals to the host device that it is communicating with an input/output device.

15 Claims, 2 Drawing Sheets

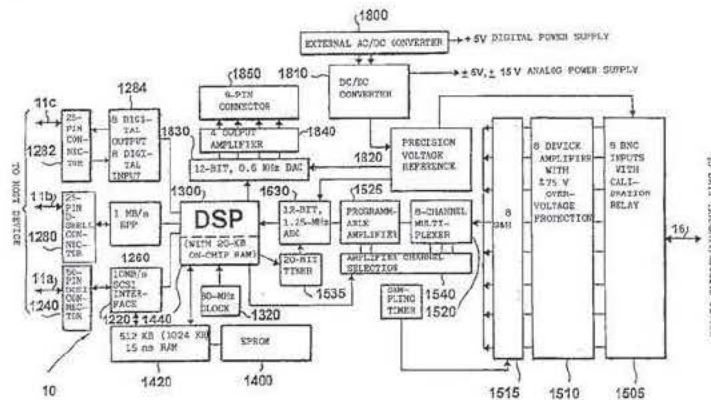

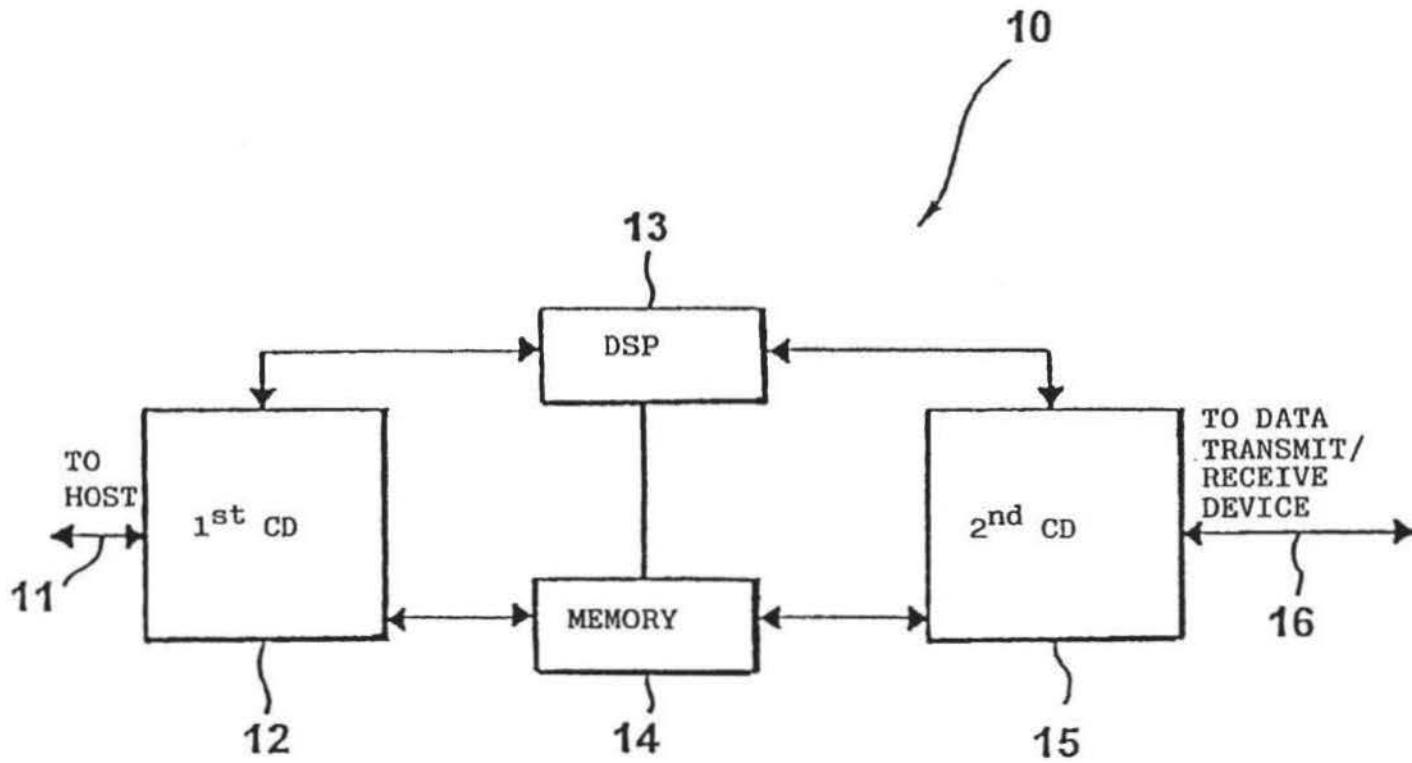

FIG. 1

U.S. Patent

Oct. 22, 2002

Sheet 1 of 2

US 6,470,399 B1

A000281

A000282

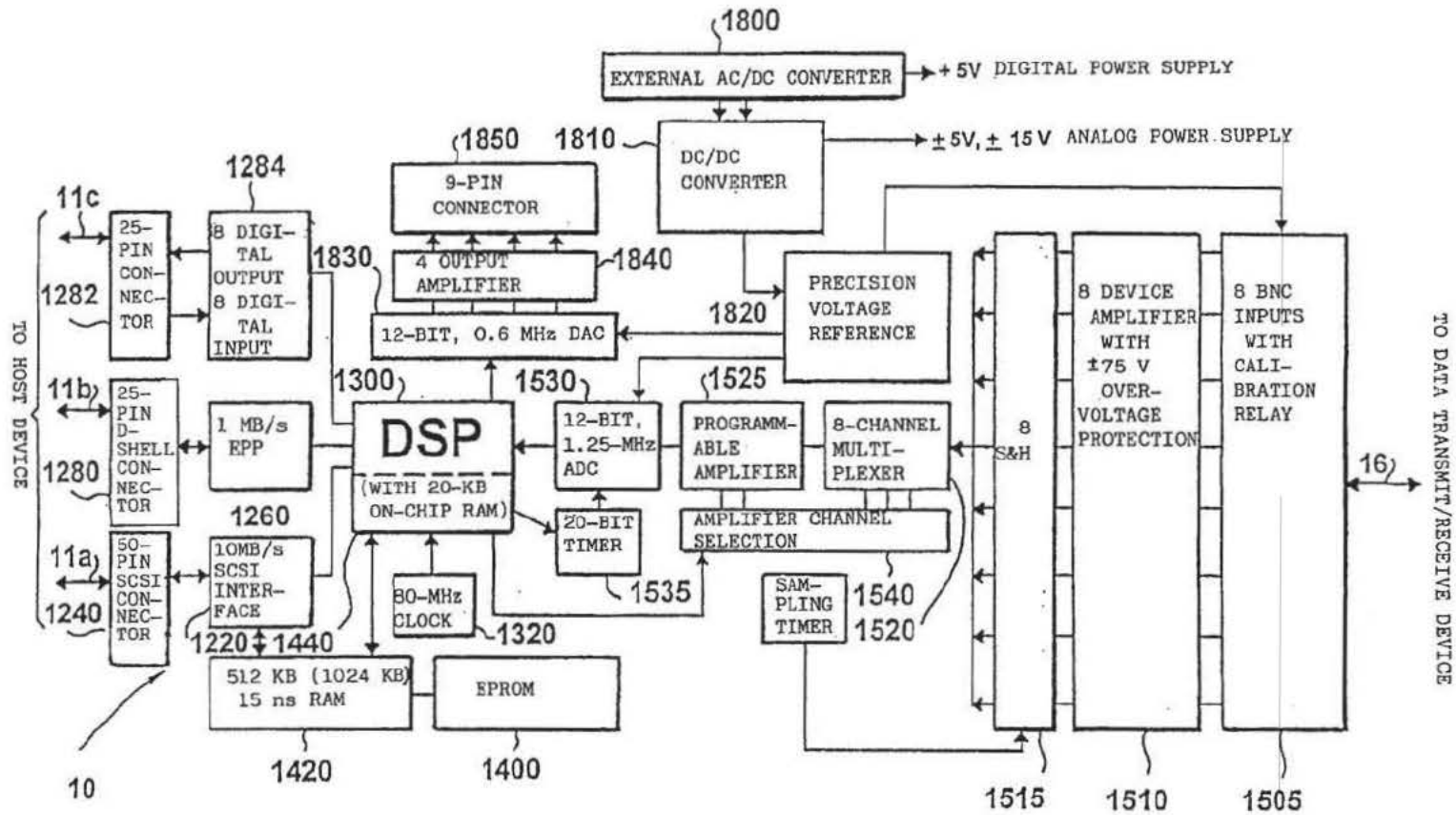

FIG. 2

U.S. Patent

Oct. 22, 2002

Sheet 2 of 2

US 6,470,399 B1

US 6,470,399 B1

1

**FLEXIBLE INTERFACE FOR
COMMUNICATION BETWEEN A HOST AND
AN ANALOG I/O DEVICE CONNECTED TO
THE INTERFACE REGARDLESS THE TYPE
OF THE I/O DEVICE**

FIELD OF THE INVENTION

The present invention relates to the transfer of data and in particular to interface devices for communication between a computer or host device and a data transmit/receive device from which data is to be acquired or with which two-way communication is to take place.

BACKGROUND OF THE INVENTION

Existing data acquisition systems for computers are very limited in their areas of application. Generally such systems can be classified into two groups.

In the first group host devices or computer systems are attached by means of an interface to a device whose data is to be acquired. The interfaces of this group are normally standard interfaces which, with specific driver software, can be used with a variety of host systems. An advantage of such interfaces is that they are largely independent of the host device. However, a disadvantage is that they generally require very sophisticated drivers which are prone to malfunction and which limit data transfer rates between the device connected to the interface and the host device and vice versa. Further, it is often very difficult to implement such interfaces for portable systems and they offer few possibilities for adaptation with the result that such systems offer little flexibility.

The devices from which data is to be acquired cover the entire electrical engineering spectrum. In a typical case, it is assumed that a customer who operates, for example, a diagnostic radiology system in a medical engineering environment reports a fault. A field service technician of the system manufacturer visits the customer and reads system log files generated by the diagnostic radiology system by means of a portable computer or laptop for example. If the fault cannot be localized or if the fault is intermittent, it will be necessary for the service technician to read not only an error log file but also data from current operation. It is apparent that in this case fast data transfer and rapid data analysis are necessary.

Another case requiring the use of an interface could be, for example, when an electronic measuring device, e.g. a multimeter, is attached to a computer system to transfer the data measured by the multimeter to the computer. Particularly when long-term measurements or large volumes of data are involved it is necessary for the interface to support a high data transfer rate.

From these randomly chosen examples it can be seen that an interface may be put to totally different uses. It is therefore desirable that an interface be sufficiently flexible to permit attachment of very different electrical or electronic systems to a host device by means of the interface. To prevent operator error, it is also desirable that a service technician is not required to operate different interfaces in different ways for different applications but that, if possible, a universal method of operating the interface be provided for a large number of applications.

To increase the data transfer rates across an interface, the route chosen in the second group of data acquisition systems for the interface devices was to specifically match the

2

interface very closely to individual host systems or computer systems. The advantage of this solution is that high data transfer rates are possible. However, a disadvantage is that the drivers for the interfaces of the second group are very closely matched to a single host system with the result that they generally cannot be used with other host systems or their use is very ineffective. Further, such types of interface have the disadvantage that they must be installed inside the computer casing to achieve maximum data transfer rates as they access the internal host bus system. They are therefore generally not suitable for portable host systems in the form of laptops whose minimum possible size leaves little internal space to plug in an interface card.

DESCRIPTION OF PRIOR ART

A solution to this problem is offered by the interface devices of IOtech (business address: 25971 Cannon Road, Cleveland, Ohio 44146, USA) which are suitable for laptops such as the WaveBook/512 (registered trademark). The interface devices are connected by means of a plug-in card, approximately the size of a credit card, to the PCMCIA interface which is now a standard feature in laptops. The plug-in card converts the PCMCIA interface into an interface known in the art as IEEE 1284. The said plug-in card provides a special printer interface which is enhanced as regards the data transfer rate and delivers a data transfer rate of approximately 2 MBps as compared with a rate of approx. 1 MBps for known printer interfaces. The known interface device generally consists of a driver component, a digital signal processor, a buffer and a hardware module which terminates in a connector to which the device whose data is to be acquired is attached. The driver component is attached directly to the enhanced printer interface thus permitting the known interface device to establish a connection between a computer and the device whose data is to be acquired.

In order to work with the said interface, an interface-specific driver must be installed on the host device so that the host device can communicate with the digital signal processor of the interface card. As described above, the driver must be installed on the host device. If the driver is a driver developed specifically for the host device, a high data transfer rate is achieved but the driver cannot be easily installed on a different host system. However, if the driver is a general driver which is as flexible as possible and which can be used on many host devices, compromises must be accepted with regard to the data transfer rate.

Particularly in an application for multi-tasking systems in which several different tasks such as data acquisition, data display and editing are to be performed quasi-simultaneously, each task is normally assigned a certain priority by the host system. A driver supporting a special task requests the central processing system of the host device for processor resources in order to perform its task. Depending on the particular priority assignment method and on the driver implementation, a particular share of processor resources is assigned to a special task in particular time slots. Conflicts arise if one or more drivers are implemented in such a way that they have the highest priority by default, i.e. they are incompatible, as happens in practice in many applications. It may occur that both drivers are set to highest priority which, in the worst case, can result in a system crash.

EP 0685799 A1 discloses an interface by means of which several peripheral devices can be attached to a bus. An interface is connected between the bus of a host device and various peripheral devices. The interface comprises a finite

US 6,470,399 B1

3

state machine and several branches each of which is assigned to a peripheral device. Each branch comprises a data manager, cycle control, user logic and a buffer. This known interface device provides optimal matching between a host device and a specific peripheral device.

The specialist publication IBM Technical Disclosure Bulletin, Vol. 38, No. 05, page 245; "Communication Method between Devices through FDD Interface" discloses an interface which connects a host device to a peripheral device via a floppy disk drive interface. The interface consists in particular of an address generator, an MFM encoder/decoder, a serial/parallel adapter and a format signal generator. The interface makes it possible to attach not only a floppy disk drive but also a further peripheral device to the FDD host controller of a host device. The host device assumes that a floppy disk drive is always attached to its floppy disk drive controller and communication is initiated if the address is correct. However, this document contains no information as to how communication should be possible if the interface is connected to a multi-purpose interface instead of to a floppy disk drive controller.

SUMMARY OF THE INVENTION

It is an object of the present invention to provide an interface device for communication between a host device and a data transmit/receive device whose use is host device-independent and which delivers a high data transfer rate.

In accordance with a first aspect of the present invention, this object is met by an interface device for communication between a host device, which comprises drivers for input/output devices customary in a host device and a multi-purpose interface, and a data transmit/receive device comprising: a processor; a memory; a first connecting device for interfacing the host device with the interface device via the multi-purpose interface of the host device; and a second connecting device for interfacing the interface device with the data transmit/receive device, wherein the interface device is configured by the processor and the memory in such a way that the interface device, when receiving an inquiry from the host device as to the type of a device attached to the multi-purpose interface of the host device, sends a signal, regardless of the type of the data transmit/receive device attached to the second connecting device of the interface device, to the host device which signals to the host device that it is an input/output device customary in a host device, whereupon the host device communicates with the interface device by means of the driver for the input/output device customary in a host device.

In accordance with a second aspect of the present invention, this object is met by an interface device for communication between a host device, which comprises a multi-purpose interface and a specific driver for this interface, and a data transmit/receive device comprising: a processor; a memory; a first connecting device for interfacing the host device with the interface device via the multi-purpose interface of the host device; and a second connecting device for interfacing the interface device with the data transmit/receive device, wherein the interface device is configured using the processor and the memory in such a way that the interface device, when receiving an inquiry from the host device as to the type of a device attached to the multi-purpose interface of the host device, sends a signal, regardless of the type of the data transmit/receive device attached to the second connecting device of the interface device, to the host device which signals to the host device that it is an input/output device customary in a host device,

4

whereupon the host device communicates with the interface device by means of the specific driver for the multi-purpose interface.

In accordance with a third aspect of the present invention, this object is met by a method of communication between a host device, which comprises drivers for input/output devices customary in a host device and a multi-purpose interface, and a data transmit/receive device via an interface device comprising the steps of interfacing of the host device with a first connecting device of the interface device via the multi-purpose interface of the host device; interfacing of the data transmit/receive device with a second connecting device of the interface device; inquiring by the host device at the interface device as to the type of device to which the multi-purpose interface of the host device is attached; regardless of the type of the data transmit/receive device attached to the second connecting device of the interface device, responding to the inquiry from the host device by the interface device in such a way that it is an input/output device customary in a host device, whereupon the host device communicates with the interface device by means of the usual driver for the input/output device.

The present invention is based on the finding that both a high data transfer rate and host device-independent use can be achieved if a driver for an input/output device customary in a host device, normally present in most commercially available host devices, is utilized. Drivers for input/output devices customary in a host device which are found in practically all host devices are, for example, drivers for hard disks, for graphics devices or for printer devices. As however the hard disk interfaces in common host devices which can be, for example, IBM PCs, IBM-compatible PCs, Commodore PCs, Apple computers or even workstations, are the interfaces with the highest data transfer rate, the hard disk driver is utilized in the preferred embodiment of the interface device of the present invention. Drivers for other storage devices such as floppy disk drives, CD-ROM drives or tape drives could also be utilized in order to implement the interface device according to the present invention.

As described in the following, the interface device according to the present invention is to be attached to a host device by means of a multi-purpose interface of the host device which can be implemented, for example, as an SCSI interface or as an enhanced printer interface. Multi-purpose interfaces comprise both an interface card and specific driver software for the interface card. The driver software can be designed so that it can replace the BIOS driver routines. Communication between the host device and the devices attached to the multi-purpose interface then essentially takes place by means of the specific driver software for the multi-purpose interface and no longer primarily by means of BIOS routines of the host device. Recently however drivers for multi-purpose interfaces can also already be integrated in the BIOS system of the host device as, alongside classical input/output interfaces, multi-purpose interfaces are becoming increasingly common in host devices. It is of course also possible to use BIOS routines in parallel with the specific driver software for the multi-purpose interface, if this is desired.

The interface device according to the present invention comprises a processor means, a memory means, a first connecting device for interfacing the host device with the interface device, and a second connecting device for interfacing the interface device with the data transmit/receive device. The interface device is configured by the processor means and the memory means in such a way that the interface device, when receiving an inquiry from the host

US 6,470,399 B1

5

device via the first connecting device as to the type of a device attached to the host device, sends a signal, regardless of the type of the data transmit/receive device, to the host device via the first connecting device which signals to the host device that it is communicating with an input/output device. The interface device according to the present invention therefore simulates, both in terms of hardware and software, the way in which a conventional input/output device functions, preferably that of a hard disk drive. As support for hard disks is implemented as standard in all commercially available host systems, the simulation of a hard disk, for example, can provide host device-independent use. The interface device according to the present invention therefore no longer communicates with the host device or computer by means of a specially designed driver but by means of a program which is present in the BIOS system (Basic Input/Output System) and is normally precisely matched to the specific computer system on which it is installed, or by means of a specific program for the multi-purpose interface. Consequently, the interface device according to the present invention combines the advantages of both groups. On the one hand, communication between the computer and the interface takes place by means of a host device-specific BIOS program or by means of a driver program which is matched to the multi-purpose interface and which could be regarded as a "device-specific driver". On the other hand, the BIOS program or a corresponding multi-purpose interface program which operates one of the common input/output interfaces in host systems is therefore present in all host systems so that the interface device according to the present invention is host device-independent.

BRIEF DESCRIPTION OF THE DRAWINGS

In the following, preferred embodiments of the present invention will be explained in more detail with reference to the drawings enclosed, in which:

FIG. 1 shows a general block diagram of the interface device according to the present invention; and

FIG. 2 shows detailed block diagram of an interface device according to a preferred embodiment of the present invention.

DETAILED DESCRIPTION OF PREFERRED EMBODIMENTS

FIG. 1 shows a general block diagram of an interface device 10 according to the present invention. A first connecting device 12 of the interface device 10 can be attached to a host device (not shown) via a host line 11. The first connecting device is attached both to a digital signal processor 13 and to a memory means 14. The digital signal processor 13 and the memory means 14 are also attached to a second connecting device 15 by means of bidirectional communication lines (shown for all lines by means of two directional arrows). The second connecting device can be attached by means of an output line 16 to a data transmit/receive device which is to receive data from the host device or from which data is to be read, i.e. acquired, and transferred to the host device. The data transmit/receive device itself can also communicate actively with the host device via the first and second connecting device, as described in more detail in the following.

Communication between the host system or host device and the interface device is based on known standard access commands as supported by all known operating systems (e.g. DOS, Windows, Unix). Preferably, the interface device

6

according to the present invention simulates a hard disk with a root directory whose entries are "virtual" files which can be created for the most varied functions. When the host device system with which the interface device according to the present invention is connected is booted and a data transmit/receive device is also attached to the interface device 10, usual BIOS routines or multi-purpose interface programs issue an instruction, known by those skilled in the art as the INQUIRY instruction, to the input/output interfaces in the host device. The digital signal processor 13 receives this inquiry instruction via the first connecting device and generates a signal which is sent to the host device (not shown) again via the first connecting device 12 and the host line 11. This signal indicates to the host device that, for example, a hard disk drive is attached to the interface to which the INQUIRY instruction was sent. Optionally, the host device can send an instruction, known by those skilled in the art as "Test Unit Ready", to the interface device to request more precise details regarding the queried device.

Regardless of which data transmit/receive device at the output line 16 is attached to the second connecting device, the digital signal processor 13 informs the host device that it is communicating with a hard disk drive. If the host device receives the response that a drive is present, it then sends a request to the interface device 10 to read the boot sequence which, on actual hard disks, normally resides on the first sectors of the disk. The digital signal processor 13, whose operating system is stored in the memory means 14, responds to this instruction by sending to the host device a virtual boot sequence which, in the case of actual drives, includes the drive type, the starting position and the length of the file allocation table (FAT), the number of sectors, etc., known to those skilled in the art. Once the host device has received this data, it assumes that the interface device 10 according to a preferred embodiment of the present invention is a hard disk drive. In reply to an instruction from the host device to display the directory of the "virtual" hard disk drive simulated by the interface device 10 with respect to the host device, the digital signal processor can respond to the host device in exactly the same way as a conventional hard disk would, namely by reading on request the file allocation table or FAT on a sector specified in the boot sequence, normally the first writable sector, and transferring it to the host device, and subsequently by transferring the directory structure of the virtual hard disk. Further, it is possible that the FAT is not read until immediately prior to reading or storing the data of the "virtual" hard disk and not already at initialization.

In a preferred embodiment of the present invention, the digital signal processor 13, which need not necessarily be implemented as a digital signal processor but may be any other kind of microprocessor, comprises a first and a second command interpreter. The first command interpreter carries out the steps described above whilst the second command interpreter carries out the read/write assignment to specific functions. If the user now wishes to read data from the data transmit/receive device via the line 16, the host device sends a command, for example "read file xy", to the interface device. As described above, the interface device appears to the host device as a hard disk. The second command interpreter of the digital signal processor now interprets the read command of the host processor as a data transfer command, by decoding whether "xy" denotes, for example, a "real-time input" file, a "configuration" file or an executable file, whereby the same begins to transfer data from the data transmit/receive device via the second connecting device to the first connecting device and via the line 11 to the host device.

US 6,470,399 B1

7

Preferably, the volume of data to be acquired by a data transmit/receive device is specified in a configuration file described in the following by the user specifying in the said configuration file that a measurement is to last, for example, five minutes. To the host device the "real-time input" file then appears as a file whose length corresponds to the anticipated volume of data in those five minutes. Those skilled in the art know that communication between a processor and a hard disk consists of the processor transferring to the hard disk the numbers of the blocks or clusters or sectors whose contents it wishes to read. By reference to the FAT the processor knows which information is contained in which block. In this case, communication between the host device and the interface device according to the present invention therefore consists of the very fast transfer of block numbers and preferably of block number ranges because a virtual "real-time input" file will not be fragmented. If the host device now wants to read the "real-time input" file, it transfers a range of block numbers to the interface device, whereupon data commences to be received via the second connecting device and data commences to be sent to the host device via the first connecting device.

In addition to the digital signal processor instruction memory, which comprises the operating system of the digital signal processor and can be implemented as an EPROM or EEPROM, the memory means 14 can have an additional buffer for purposes of synchronizing data transfer from the data transmit/receive device to the interface device 10 and data transfer from the interface device 10 to the host device.

Preferably, the buffer is implemented as a fast random access memory or RAM buffer.

Further, from the host device the user can also create a configuration file, whose entries automatically set and control various functions of the interface device 10, on the interface device 10 which appears to the host device as a hard disk. These settings can be, for example, gain, multiplex or sampling rate settings. By creating and editing a configuration file, normally a text file which is simple to understand with little prior knowledge, users of the interface device 10 are able to perform essentially identical operator actions for almost any data transmit/receive devices which can be attached to the second connecting device via the line 16, thus eliminating a source of error arising from users having to know many different command codes for different applications. In the case of the interface device 10 according to the present invention it is necessary for users to note the conventions of the configuration file once only in order to be able to use the interface device 10 as an interface between a host device and almost any data transmit/receive device.

As a result of the option of storing any files in agreed formats in the memory means 14 of the interface device 10, taking into account the maximum capacity of the memory means, any enhancements or even completely new functions of the interface device 10 can be quickly implemented. Even files executable by the host device, such as batch files or executable files (BAT or EXE files), and also help files can be implemented in the interface device, thus achieving independence of the interface device 10 from any additional software (with the exception of the BIOS routines) of the host device. On the one hand, this avoids licensing and/or registration problems and, on the other hand, installation of certain routines which can be frequently used, for example an FFT routine to examine acquired time-domain data in the frequency domain, is rendered unnecessary as the EXE files are already installed on the interface device 10 and appear in the virtual root directory, by means of which the host device can access all programs stored on the interface device 10.

8

In a preferred embodiment of the present invention in which the interface device 10 simulates a hard disk to the host device, the interface device is automatically detected and readied for operation when the host system is powered up or booted. This corresponds to the plug-and-play standard which is currently finding increasingly widespread use. The user is no longer responsible for installing the interface device 10 on the host device by means of specific drivers which must also be loaded; instead the interface device 10 is automatically readied for operation when the host system is booted.

For persons skilled in the art it is however obvious that the interface device 10 is not necessarily signed on when the computer system is powered up but that a special BIOS routine or a driver for a multi-purpose interface can also be started on the host device during current operation of the computer system in order to sign on or mount the interface device 10 as an additional hard disk. This embodiment is suitable for larger workstation systems which are essentially never powered down as they perform, e.g. mail functions or monitor processes which run continuously, for example, in multi-tasking environments.

In the interface device according to the present invention an enormous advantage is to be gained, as apparent in the embodiment described in the following, in separating the actual hardware required to attach the interface device 10 to the data transmit/receive device from the communication unit, which is implemented by the digital signal processor 13, the memory means 14 and the first connecting device 12, as this allows a plurality of dissimilar device types to be operated in parallel in identical manner. Accordingly, many interface devices 10 can be connected to a host device which then sees many different "virtual" hard disks. In addition, any modification of the specific hardware symbolized by the second connecting device 15 can be implemented essentially without changing the operation of the interface device according to the present invention. Further, an experienced user can intervene at any time on any level of the existing second connecting device by making use of the above mentioned option of creating a configuration file or adding or storing new program sections for the second connecting device.

An important advantage of the interface device 10 of the present invention is that it also permits extremely high data transfer rates by using, for data interchange, the host device-own BIOS routines which are optimized for each host device by the host device manufacturer or BIOS system manufacturer, or by using driver programs which are normally optimized and included by the manufacturers of multi-purpose interfaces. Furthermore, due to the simulation of a virtual mass storage device, the data is managed and made available in such a way that it can be transferred directly to other storage media, e.g. to an actual hard disk of the host device without, as it were, intervention of the host device processor. The only limitation to long-term data transfer at high speed is therefore imposed exclusively by the speed and the size of the mass storage device of the host device. This is the case as the digital signal processor 13 already formats the data read by the data transmit/receive device via the second connecting device 15 into block sizes suitable for a hard disk of the host device, whereby the data transfer speed is limited only by the mechanical latency of the hard disk system of the host device. At this point, it should be noted that normally data flow from a host device must be formatted in blocks to permit writing to a hard disk and subsequent reading from a hard disk, as known by those skilled in the art.

US 6,470,399 B1

9

The said data transfer rate can be increased further by setting up a direct memory access (DMA) or RAM drive in the host system. As those skilled in the art know, the setting up of a RAM drive requires processor resources of the host device, with the result that the advantage of writing the data to a hard disk drive of the host device essentially without the need for processor resources is lost.

As described above, a data buffer can be implemented in the memory means 14 to permit independence in terms of time of the data transmit/receive device attached to the second connecting device from the host device attached to the first connecting device. This guarantees error-free operation of the interface device 10 even for time-critical applications in multi-tasking host systems.

FIG. 2 shows a detailed block diagram of an interface device 10 according to the present invention.

A digital signal processor (DSP) 1300 is, in a manner of speaking, the heart of the interface device 10. The DSP can be any DSP but preferably has a 20-MB on-chip random access memory (RAM). Certain instruction sets, for example, can be stored in the RAM already integrated in the DSP. An 80-MHz clock generator is attached to the DSP 1300 in order to synchronize the DSP. The DSP implements a fast Fourier transformation (FFT) in real time and also optional data compression of the data to be transferred from the data transmit/receive device to the host device in order to achieve greater efficiency and to permit interoperation with host devices which have a smaller memory.

In the preferred embodiment of the interface device 10 shown in FIG. 2, the first connecting device 12 of FIG. 1 contains the following components: an SCSI interface 1220 and a 50-pin SCSI connector 1240 for attachment to an SCSI interface present on most host devices or laptops. The SCSI (small computer system interface) interface 1220 translates the data received via the SCSI connector 1240 into data understood by the DSP 1300, as known by those skilled in the art. Further, the first connecting device 12 comprises an EPP (enhanced parallel port) with a data transfer rate of approx. 1 MBps which delivers a more moderate data transfer rate of 1 MBps by comparison to the data transfer rate of 10 MBps of the SCSI interface. The EPP 1260 is connected to a 25-pin D-shell connector 1280 to permit attachment to a printer interface of a host device for example. Optionally, the first connecting device 12 also comprises a 25-pin connector 1282 which permits the attachment of 8 digital outputs and 8 digital inputs 1284 at a host device.

Preferably, the second connecting device comprises 8 BNC inputs with the calibration relay 1505, a block 1510 with 8 device amplifiers with an overvoltage protection of ± 75 V, this block being connected in turn to 8 sample/hold (S&H) circuits 1515. The calibration relays are relays which permit controlled changeover between a test voltage and a calibration reference voltage. Each sample/hold circuit is connected to a corresponding input of an 8-channel multiplexer 1520 which feeds its output signals via a programmable amplifier 1525 into an analog/digital converter (ADC) with 12 bit and 1.25 MHz 1530 and to the DSP 1300. The ADC 1530 is controlled by means of a 20-bit timer 1535, as known by persons skilled in the art. The programmable amplifier 1525 and the 8-channel multiplexer 1520 are controlled via an amplifier channel selection circuit 1540 which is in turn controlled by the DSP 1300.

The complete interface device 10 is supplied with power by an external AC/DC converter 1800 which delivers a digital supply voltage of ± 5 V and is attached to a DC/DC

10

converter 1810 which can deliver analog supply voltages of ± 5 V and ± 15 V as required for the interface device 10. Further, the DC/DC converter controls a precision voltage reference 1820 which controls the 8 BNC inputs 1505 and the ADC 1530 as well as a digital/analog converter (DAC) 1830 which permits, via an output amplifier block with 4 output amplifiers 1840 and a 9-pin connector 1850, analog output direct from the DSP 1300 to an output device, e.g. printer device or monitor device, which can be attached via the 9-pin connector 1850, thus providing the option of monitoring the data transferred to the host device or also, for example, of viewing an FFT to obtain rapid and comprehensive data analysis without using processor time of the host device.

In FIG. 2 the memory means 14 of FIG. 1 is implemented by an EPROM 1400 which, in a preferred embodiment of the present invention, contains the operating system of the digital signal processor 1300. A random access memory with an access time of 15 ns and a size of 512 KB or optionally 1024 KB 1420 serves as a data buffer to achieve independence in terms of time of the output line 16 from the output lines 11a, 11b and 11c to the data transmit/receive device and to the host device respectively. As described above, in a preferred embodiment of the present invention the digital signal processor 1300 already contains a 20-KB on-chip RAM 1440 which can store certain instruction sets, functions and also smaller application software units.

The connection, symbolized by the line 16, of the interface device 10 to any data transmit/receive device implements, by means of the blocks 1505–1535, an analog input with a sampling rate of 1.25 MHz and quantization of 12 bits. There are 8 channels with an overvoltage protection of ± 75 V. By means of the programmable amplifier 1525 the channels can be programmed independently of each other in voltage ranges up to a maximum of ± 10 V. Unused channels can be grounded internally to reduce channel intermodulation. The block 1515 is implemented as a monolithic high-precision, high-speed sample/hold amplifier for simultaneous sampling of all channels. The precision voltage reference 1820 provides a high-precision, temperature-compensated monolithic energy gap voltage reference for auto-calibration of each channel and each gain. Further, offset fine adjustment for each channel is implemented by the same.

The blocks 1830, 1840 and 1850 implement a direct analog output for the digital signal processor 1300, and the DAC 1830 provides a data transfer rate of 625 kHz and a quantization of 12 bits. The block 1840 comprises 4 channels with a common output latch.

Further, the interface device 10 comprises a digital input/output device implemented by the blocks 1284 and 1282. Here there are 8 digital inputs, 8 digital outputs with a common latch, and the digital port can be attached preferably to a side panel of the interface device 10 so that the port itself can easily be accessed.

The digital signal processor 1300 provides on-board digital data processing. In particular, it is a high-performance DSP with a clock speed of 80 MHz and a 20-bit timer 1535.

As described above, the first connecting device 12 comprises the SCSI interface 1220 with a peak transfer rate of 10 MBps. An optional PCMCIA-to-SCSI adapter permits high-speed communication with laptop computers which are desirable and in widespread use, particularly by mobile service technicians. The EPP 1260 with its associated connector 1280 permits data transfer at a more moderate rate.

As described above, the interface device 10 is supplied with power by means of an external AC/DC adapter which

US 6,470,399 B1

11

has a universal power input (85–264 VAC, 47–63 Hz). Interference suppression complies with the standards EN 55022, curve B and FFC, Class B). Further, it is also in accordance with international safety regulations (TÜV, UL, CSA). The interface device **10** is externally shielded and achieves a value of 55 dB at 30–60 MHz and a value of approximately 40 dB at 1 GHz, and therefore complies with the MILSTD 285-1 standard.

As described above, communication between the host device and the multi-purpose interface can take place not only via drivers for input/output device customary in a host device which reside in the BIOS system of the host device but also via specific interface drivers which, in the case of SCSI interfaces, are known as multi-purpose interface ASPI (advanced SCSI programming interface) drivers. This ASPI driver, which can also be referred to as an ASPI manager, is specific to a special SCSI host adapter, i.e. to a special multi-purpose interface, and is normally included by the manufacturer of the multi-purpose interface. Generally speaking, this multi-purpose interface driver has the task of moving precisely specified SCSI commands from the host system program to the host system SCSI adapter. For this reason, the command set is almost identical to that of the SCSI interface itself. Essentially, only status and reset commands for the host adapter have been added.

The ASPI driver can be used if the hard disk was not already addressable at boot time or if the SCSI-related BIOS routines of the host computer were still disabled. Here too, the steps needed to initialize the interface device, preferably as a virtual hard disk, are similar to the steps taken when initializing at boot time.

In general terms, the ASPI manager comprises two sides. One side is the proprietary, hardware-oriented side. It is responsible for converting all commands into a form required by the corresponding multi-purpose interface. The hardware-oriented side of the ASPI driver is therefore matched to a very specific type of multi-purpose interface or SCSI interface. The other side is known as the user software side. This side is totally independent of the proprietary operating characteristics of the SCSI adapter and is therefore identical for all SCSI interfaces. This permits SCSI programming which is however independent of the individual SCSI adapter types.

In contrast to communication between the host device and the interface device according to the present invention on the basis of a BIOS driver, the use of such an ASPI driver for communication between the host device and the interface device according to the present invention allows various further possibilities of the SCSI multi-purpose interface to be exploited. In the case described above, the interface device which preferably signs on and behaves as a virtual hard disk is detected by the BIOS driver of the host computer at boot time and is configured as a hard disk. This step does not however support active requests sent by the interface device to the host computer. If however the virtual hard disk wishes to write data actively to, for example, a hard disk of the host computer or wishes to initiate communication with the processor of the host computer, the host computer must recognize the request of the virtual hard disk and tolerate a further issuer of instructions on its bus. If the interface device behaves solely like a virtual hard disk, it would always receive and never issue commands. The BIOS has no objections to an additional issuer of commands that actively wishes to place data on the bus of the host device but the BIOS does not support the host device in recognizing corresponding requests of the interface device or in granting the interface device permission to access the bus.

Using the ASPI manager the interface device according to the present invention can now obtain active access to an

12

SCSI hard disk of the host device connected to the same SCSI bus which, in contrast to the interface device, cannot be a virtual but a real SCSI mass storage device or also a further interface device according to the present invention. Thereupon, the interface device according to the present invention can write the desired data to the SCSI hard disk of the host computer totally independently of the host computer or can communicate with the same in some other manner. The interface device according to the present invention therefore initially behaves passively as a virtual hard disk and then, as required and using the driver software for the multi-purpose interface, actively on the same SCSI bus. This means however that the interface device according to the present invention, using a driver software for the multi-purpose interface which comprises the BIOS routines customary in host devices and simultaneously provides the option of active participation, can, regardless of the type of the data transmit/receive device attached to the second connecting device, behave initially as a virtual and at the same time passive hard disk but can, as required, participate actively on the bus so as to be able to initiate communication directly with other SCSI hard disks of the host device by bypassing the processor of the host device.

Using a standard interface of a host device, the interface device according to the present invention permits communication with any host device. By simulating an input/output device to the host device and, in a preferred embodiment, by simulating a virtual mass storage device, the interface device **10** is automatically supported by all known host systems without any additional sophisticated driver software. The simulation of a freely definable file structure on the “virtual” hard disk provides simple operation and expansion options and, through the implementation of any programs, independence from special software implemented on the host device. Help files included on the interface device **10** and plug-and-play support ensure ease of use even in portable, flexible host devices. Despite the very simple user interface, experienced users are free at any time to intervene in the functions of the interface device **10** on system level. The interface device **10** thus provides a universal solution which can cover the entire spectrum of possible data transmit/receive devices.

What is claimed is:

1. An interface device for communication between a host device, which comprises drivers for input/output devices customary in a host device and a multi-purpose interface, and a data transmit/receive device, the data transmit/receive device being arranged for providing analog data, comprising:

- a processor;
- a memory;
- a first connecting device for interfacing the host device with the interface device via the multi-purpose interface of the host device; and
- a second connecting device for interfacing the interface device with the data transmit/receive device, the second connecting device including a sampling circuit for sampling the analog data provided by the data transmit/receive device and an analog-to-digital converter for converting data sampled by the sampling circuit into digital data,

wherein the interface device is configured by the processor and the memory to include a first command interpreter and a second command interpreter,

wherein the first command interpreter is configured in such a way that the command interpreter, when receiving an inquiry from the host device as to a type of a device attached to the multi-purpose interface of the

US 6,470,399 B1

13

host device, sends a signal, regardless of the type of the data transmit/receive device attached to the second connecting device of the interface device, to the host device which signals to the host device that it is an input/output device customary in a host device, whereupon the host device communicates with the interface device by means of the driver for the input/output device customary in a host device, and

wherein the second command interpreter is configured to interpret a data request command from the host device to the type of input/output device signaled by the first command interpreter as a data transfer command for initiating a transfer of the digital data to the host device.

2. An interface device according to claim 1, wherein the drivers for input/output drivers customary in a host device comprise a hard disk driver, and the signal indicates to the host device that the host device is communicating with a hard disk.

3. An interface device according to claim 1, wherein the memory means comprises a buffer to buffer data to be transferred between the data transmit/receive device and the host device.

4. An interface device according to claim 1, wherein the multi-purpose interface of the host device is an SCSI interface and the first connecting device also comprises an SCSI interface.

5. An interface device according to claim 1, wherein the processor is a digital signal processor.

6. An interface device according to claim 2, wherein the data to be transferred from the data transmit/receive device to the host device in the interface device is formatted in a suitable format for a hard disk present in the host device.

7. An interface device according to claim 2, which further comprises a root directory and virtual files which are present on the signaled hard disk drive and which can be accessed from the host device.

8. An interface device according to claim 7, wherein the virtual files comprise a configuration file in text format which are stored in the memory means and using which the user can configure the interface device for a specific data transmit/receive device.

9. An interface device according to claim 7, wherein the virtual files comprise batch files or executable files for the microprocessor means which are stored in the interface device in order to perform data processing, independently of the host device, of data received via the second connecting device.

10. An interface device according to claim 7, wherein the virtual files comprise batch files or executable files for the host device which are stored in the interface device.

11. An interface device for communication between a host device, which comprises a multi-purpose interface and a specific driver for this interface, and a data transmit/receive device, the data transmit/receive device being arranged for providing analog data, comprising:

- a processor;
- a memory;
- a first connecting device for interfacing the host device with the interface device via the multi-purpose interface of the host device; and
- a second connecting device for interfacing the interface device with the data transmit/receive device, the second connecting device including a sampling circuit for sampling the analog data provided by the data transmit/receive device and an analog-to-digital converter for converting data sampled by the sampling circuit into digital data,

14

where the interface device is configured using the processor and the memory to include a first command interpreter and a second command interpreter,

wherein the first command interpreter is configured in such a way that the interface device, when receiving an inquiry from the host device as to the type of a device attached at the multi-purpose interface of the host device, sends a signal, regardless of the type of the data transmit/receive device attached to the second connecting device of the interface device, to the host device which signals to the host device that it is an input/output device customary in a host device, whereupon the host device communicates with the interface device by means of the specific driver for the multi-purpose interface, and

wherein the second command interpreter is configured to interpret a data request command from the host device to the type of input/output device signaled by the first command interpreter as a data transfer command for initiating a transfer of the digital data to the host device.

12. An interface device according to claim 11, wherein in addition to the first connecting device of the interface device, there is a further input/output device at the multi-purpose interface of the host device, and wherein the interface device can communicate directly with said further input/output device via the specific driver for the multi-purpose interface.

13. An interface device according to claim 11, wherein the multi-purpose interface is an SCSI interface, and wherein the specific driver for the multi-purpose interface is an ASPI manager.

14. A method of communication between a host device, which comprises drivers for input/output devices customary in a host device and a multi-purpose interface, and a data transmit/receive device, the data transmit/receive device being arranged for providing analog data, via an interface device, comprising:

- interfacing of the host device with a first connecting device of the interface device via the multi-purpose interface of the host device;
- interfacing of the data transmit/receive device with a second connecting device of the interface device, the second connecting device including a sampling circuit for sampling the analog data provided by the data/transmit/receive device and an analog-to-digital converter for converting data sampled by the sampling circuit into digital data;
- inquiring by the host device at the interface device as to the type of device to which the multi-purpose interface of the host device is attached;
- regardless of the type of the data transmit/receive data attached to the second connecting device of the interface device, responding to the inquiry from the host device by the interface device in such a way that it is an input/output device customary in a host device, whereupon the host device communicates with the interface device by means of the usual driver for the input/output device, and
- interpreting a data request command from the host device to the type of input/output device customary in the host device as a data transfer command for initiating a transfer of the digital data to the host device.

15. A method according to claim 14, wherein the drivers for input/output devices customary in a host device comprise a driver for a storage device and in particular for a hard disk drive.

* * * * *



US006895449B2

(12) **United States Patent**
Tasler

(10) Patent No.: **US 6,895,449 B2**
(45) Date of Patent: **May 17, 2005**

(54) **FLEXIBLE INTERFACE FOR COMMUNICATION BETWEEN A HOST AND AN ANALOG I/O DEVICE CONNECTED TO THE INTERFACE REGARDLESS THE TYPE OF THE I/O DEVICE**

(75) Inventor: **Michael Tasler, Wuerzburg (DE)**

(73) Assignee: **Labortechnik Tasler GmbH, Wuerzburg (DE)**

(*) Notice: Subject to any disclaimer, the term of this patent is extended or adjusted under 35 U.S.C. 154(b) by 369 days.

(21) Appl. No.: **10/219,105**

(22) Filed: **Aug. 15, 2002**

(65) **Prior Publication Data**

US 2002/0199037 A1 Dec. 26, 2002

Related U.S. Application Data

(62) Division of application No. 09/331,002, filed on Jun. 14, 1999.

(30) **Foreign Application Priority Data**

Mar. 4, 1997 (DE) 197 08 755
Mar. 3, 1998 (EP) PCT/EP98/01187

(51) Int. Cl.⁷ **G06F 13/14**

(52) U.S. Cl. **710/16; 710/8; 710/64; 709/220**

(58) Field of Search 710/8, 16, 64, 710/11, 12, 15, 62, 63; 703/23, 24, 25; 709/220, 222

(56) **References Cited**

U.S. PATENT DOCUMENTS

5,548,783 A	*	8/1996	Jones et al.	710/16
5,596,628 A	*	1/1997	Klein	379/93.11
5,628,030 A	*	5/1997	Tuckner	710/64
6,012,113 A	*	1/2000	Tuckner	710/64
6,266,711 B1	*	7/2001	Ishikawa et al.	710/8
6,363,081 B1	*	3/2002	Gase	370/466
6,725,293 B1	*	4/2004	Nakayama et al.	710/36
6,728,844 B2	*	4/2004	Sanada et al.	711/152

* cited by examiner

Primary Examiner—Jeffrey Gaffin
Assistant Examiner—Harold Kim
(74) *Attorney, Agent, or Firm*—Glenn Patent Group; Michael A. Glenn

(57) **ABSTRACT**

An interface device (10) provides fast data communication between a host device with input/output interfaces and a data transmit/receive device, wherein the interface device (10) comprises a processor means (13), a memory means (14), a first connecting device (12) for interfacing the host device with the interface device, and a second connecting device (15) for interfacing the interface device (10) with the data transmit/receive device. The interface device (10) is configured by the processor means (13) and the memory means (14) in such a way that, when receiving an inquiry from the host device via the first connecting device (12) as to the type of a device attached to the host device, regardless of the type of the data transmit/receive device, the interface device sends a signal to the host device via the first connecting device (12) which signals to the host device that it is communicating with an input/output device.

18 Claims, 2 Drawing Sheets

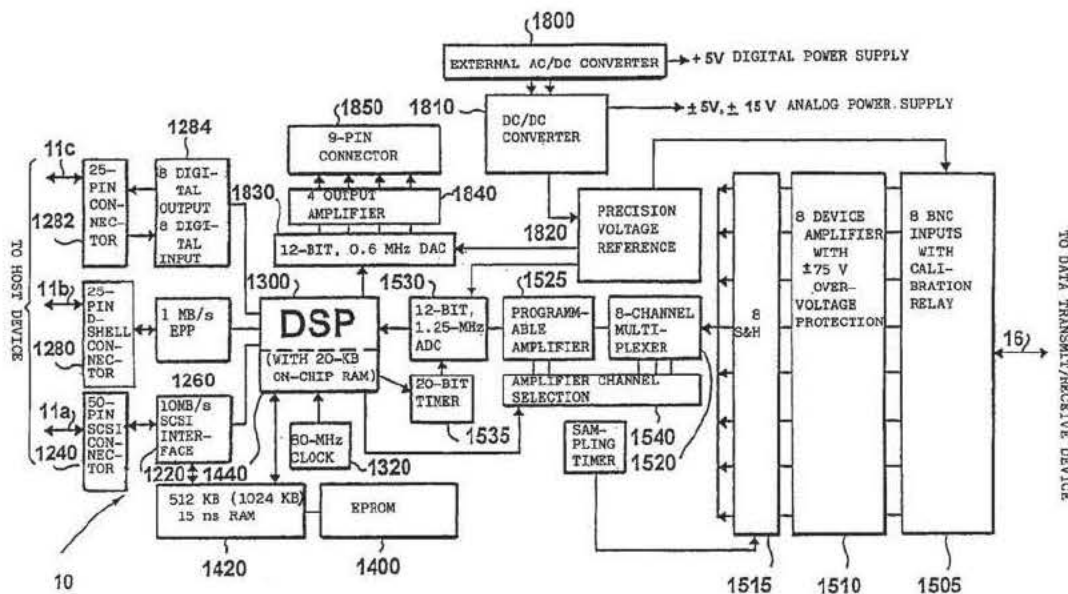

U.S. Patent

May 17, 2005

Sheet 1 of 2

US 6,895,449 B2

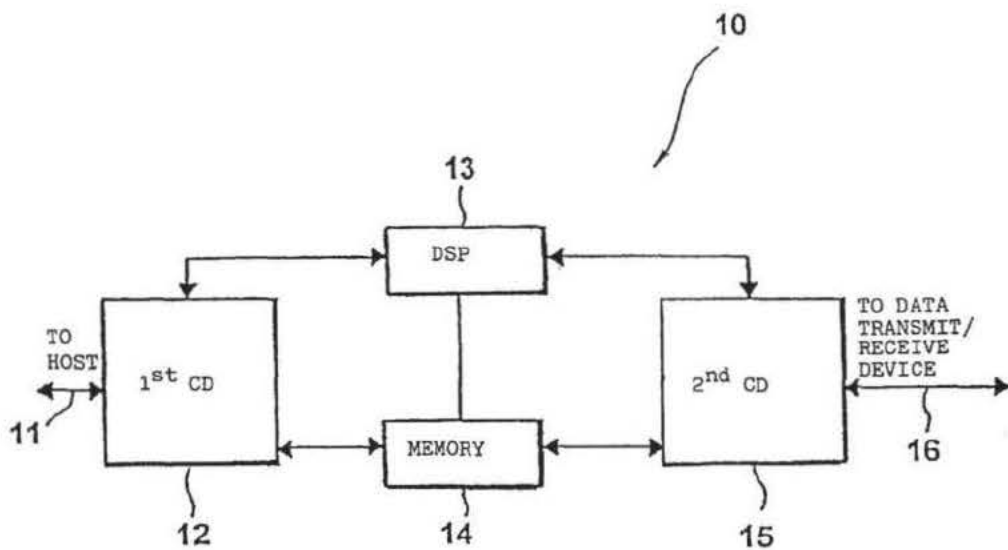

FIG. 1

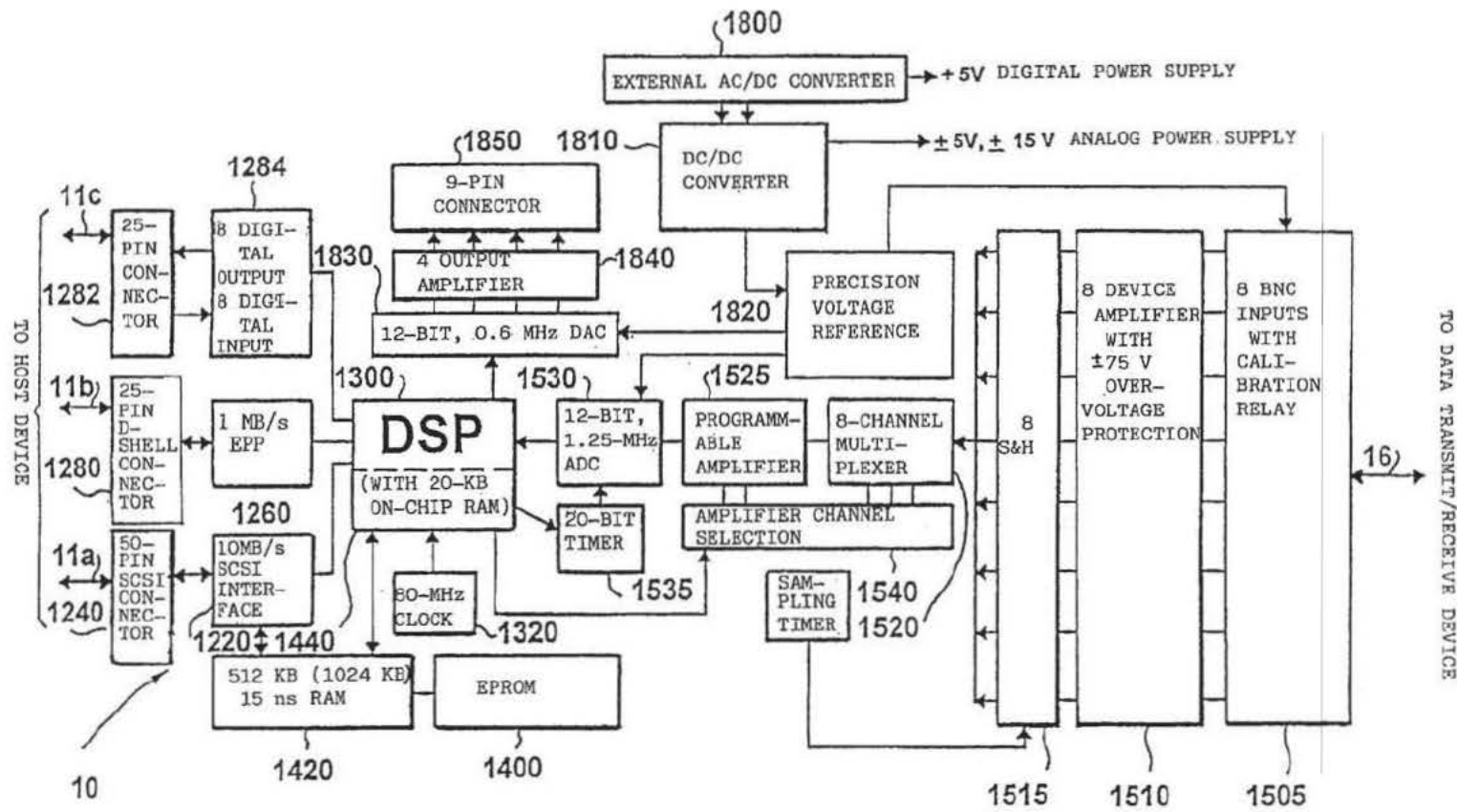

FIG. 2

U.S. Patent May 17, 2005 Sheet 2 of 2 US 6,895,449 B2

US 6,895,449 B2

1

**FLEXIBLE INTERFACE FOR
COMMUNICATION BETWEEN A HOST AND
AN ANALOG I/O DEVICE CONNECTED TO
THE INTERFACE REGARDLESS THE TYPE
OF THE I/O DEVICE**

RELATED APPLICATIONS

This application is a divisional application of copending application Ser. No. 09/331,002 filed Jun. 14, 1999.

DESCRIPTION

The present invention relates to the transfer of data and in particular to interface devices for communication between a computer or host device and a data transmit/receive device from which data is to be acquired or with which two-way communication is to take place.

Existing data acquisition systems for computers are very limited in their areas of application. Generally such systems can be classified into two groups.

In the first group host devices or computer systems are attached by means of an interface to a device whose data is to be acquired. The interfaces of this group are normally standard interfaces which, with specific driver software, can be used with a variety of host systems. An advantage of such interfaces is that they are largely independent of the host device. However, a disadvantage is that they generally require very sophisticated drivers which are prone to malfunction and which limit data transfer rates between the device connected to the interface and the host device and vice versa. Further, it is often very difficult to implement such interfaces for portable systems and they offer few possibilities for adaptation with the result that such systems offer little flexibility.

The devices from which data is to be acquired cover the entire electrical engineering spectrum. In a typical case, it is assumed that a customer who operates, for example, a diagnostic radiology system in a medical engineering environment reports a fault. A field service technician of the system manufacturer visits the customer and reads system log files generated by the diagnostic radiology system by means of a portable computer or laptop for example. If the fault cannot be localized or if the fault is intermittent, it will be necessary for the service technician to read not only an error log file but also data from current operation. It is apparent that in this case fast data transfer and rapid data analysis are necessary.

Another case requiring the use of an interface could be, for example, when an electronic measuring device, e.g. a multimeter, is attached to a computer system to transfer the data measured by the multimeter to the computer. Particularly when long-term measurements or large volumes of data are involved it is necessary for the interface to support a high data transfer rate.

From these randomly chosen examples it can be seen that an interface may be put to totally different uses. It is therefore desirable that an interface be sufficiently flexible to permit attachment of very different electrical or electronic systems to a host device by means of the interface. To prevent operator error, it is also desirable that a service technician is not required to operate different interfaces in different ways for different applications but that, if possible, a universal method of operating the interface be provided for a large number of applications.

To increase the data transfer rates across an interface, the route chosen in the second group of data acquisition systems

2

for the interface devices was to specifically match the interface very closely to individual host systems or computer systems. The advantage of this solution is that high data transfer rates are possible. However, a disadvantage is that the drivers for the interfaces of the second group are very closely matched to a single host system with the result that they generally cannot be used with other host systems or their use is very ineffective. Further, such types of interface have the disadvantage that they must be installed inside the computer casing to achieve maximum data transfer rates as they access the internal host bus system. They are therefore generally not suitable for portable host systems in the form of laptops whose minimum possible size leaves little internal space to plug in an interface card.

A solution to this problem is offered by the interface devices of IOTech (business address: 25971 Cannon Road, Cleveland, Ohio 44146, USA) which are suitable for laptops such as the WaveBook/512 (registered trademark). The interface devices are connected by means of a plug-in card, approximately the size of a credit card, to the PCMCIA interface which is now a standard feature in laptops. The plug-in card converts the PCMCIA interface into an interface known in the art as IEEE 1284. The said plug-in card provides a special printer interface which is enhanced as regards the data transfer rate and delivers a data transfer rate of approximately 2 MBps as compared with a rate of approx. 1 MBps for known printer interfaces. The known interface device generally consists of a driver component, a digital signal processor, a buffer and a hardware module which terminates in a connector to which the device whose data is to be acquired is attached. The driver component is attached directly to the enhanced printer interface thus permitting the known interface device to establish a connection between a computer and the device whose data is to be acquired.

In order to work with the said interface, an interface-specific driver must be installed on the host device so that the host device can communicate with the digital signal processor of the interface card. As described above, the driver must be installed on the host device. If the driver is a driver developed specifically for the host device, a high data transfer rate is achieved but the driver cannot be easily installed on a different host system. However, if the driver is a general driver which is as flexible as possible and which can be used on many host devices, compromises must be accepted with regard to the data transfer rate.

Particularly in an application for multi-tasking systems in which several different tasks such as data acquisition, data display and editing are to be performed quasi-simultaneously, each task is normally assigned a certain priority by the host system. A driver supporting a special task requests the central processing system of the host device for processor resources in order to perform its task. Depending on the particular priority assignment method and on the driver implementation, a particular share of processor resources is assigned to a special task in particular time slots. Conflicts arise if one or more drivers are implemented in such a way that they have the highest priority by default, i.e. they are incompatible, as happens in practice in many applications. It may occur that both drivers are set to highest priority which, in the worst case, can result in a system crash.

EP 0685799 A1 discloses an interface by means of which several peripheral devices can be attached to a bus. An interface is connected between the bus of a host device and various peripheral devices. The interface comprises a finite state machine and several branches each of which is assigned to a peripheral device. Each branch comprises a

US 6,895,449 B2

3

data manager, cycle control, user logic and a buffer. This known interface device provides optimal matching between a host device and a specific peripheral device.

The specialist publication IBM Technical Disclosure Bulletin, Vol. 38, No. 05, page 245; "Communication Method between Devices through FDD Interface" discloses an interface which connects a host device to a peripheral device via a floppy disk drive interface. The interface consists in particular of an address generator, an MFM encoder/decoder, a serial/parallel adapter and a format signal generator. The interface makes it possible to attach not only a floppy disk drive but also a further peripheral device to the FDD host controller of a host device. The host device assumes that a floppy disk drive is always attached to its floppy disk drive controller and communication is initiated if the address is correct. However, this document contains no information as to how communication should be possible if the interface is connected to a multi-purpose interface instead of to a floppy disk drive controller.

It is the object of the present invention to provide an interface device for communication between a host device and a data transmit/receive device whose use is host device-independent and which delivers a high data transfer rate.

This object is achieved by an interface device according to claim 1 or 12 and by a method according to claim 15.

The present invention is based on the finding that both a high data transfer rate and host device-independent use can be achieved if a driver for an input/output device customary in a host device, normally present in most commercially available host devices, is utilized. Drivers for input/output devices customary in a host device which are found in practically all host devices are, for example, drivers for hard disks, for graphics devices or for printer devices. As however the hard disk interfaces in common host devices which can be, for example, IBM PCs, IBM-compatible PCs, Commodore PCs, Apple computers or even workstations, are the interfaces with the highest data transfer rate, the hard disk driver is utilized in the preferred embodiment of the interface device of the present invention. Drivers for other storage devices such as floppy disk drives, CD-ROM drives or tape drives could also be utilized in order to implement the interface device according to the present invention.

As described in the following, the interface device according to the present invention is to be attached to a host device by means of a multi-purpose interface of the host device which can be implemented, for example, as an SCSI interface or as an enhanced printer interface. Multi-purpose interfaces comprise both an interface card and specific driver software for the interface card. The driver software can be designed so that it can replace the BIOS driver routines. Communication between the host device and the devices attached to the multi-purpose interface then essentially takes place by means of the specific driver software for the multi-purpose interface and no longer primarily by means of BIOS routines of the host device. Recently however drivers for multi-purpose interfaces can also already be integrated in the BIOS system of the host device as, alongside classical input/output interfaces, multi-purpose interfaces are becoming increasingly common in host devices. It is of course also possible to use BIOS routines in parallel with the specific driver software for the multi-purpose interface, if this is desired.

The interface device according to the present invention comprises a processor means, a memory means, a first connecting device for interfacing the host device with the interface device, and a second connecting device for inter-

4

facing the interface device with the data transmit/receive device. The interface device is configured by the processor means and the memory means in such a way that the interface device, when receiving an inquiry from the host device via the first connecting device as to the type of a device attached to the host device, sends a signal, regardless of the type of the data transmit/receive device, to the host device via the first connecting device which signals to the host device that it is communicating with an input/output device. The interface device according to the present invention therefore simulates, both in terms of hardware and software, the way in which a conventional input/output device functions, preferably that of a hard disk drive. As support for hard disks is implemented as standard in all commercially available host systems, the simulation of a hard disk, for example, can provide host device-independent use. The interface device according to the present invention therefore no longer communicates with the host device or computer by means of a specially designed driver but by means of a program which is present in the BIOS system (Basic Input/Output System) and is normally precisely matched to the specific computer system on which it is installed, or by means of a specific program for the multi-purpose interface. Consequently, the interface device according to the present invention combines the advantages of both groups. On the one hand, communication between the computer and the interface takes place by means of a host device-specific BIOS program or by means of a driver program which is matched to the multi-purpose interface and which could be regarded as a "device-specific driver". On the other hand, the BIOS program or a corresponding multi-purpose interface program which operates one of the common input/output interfaces in host systems is therefore present in all host systems so that the interface device according to the present invention is host device-independent.

In the following, preferred embodiments of the present invention will be explained in more detail with reference to the drawings enclosed, in which:

FIG. 1 shows a general block diagram of the interface device according to the present invention; and

FIG. 2 shows a detailed block diagram of an interface device according to a preferred embodiment of the present invention.

FIG. 1 shows a general block diagram of an interface device 10 according to the present invention. A first connecting device 12 of the interface device 10 can be attached to a host device (not shown) via a host line 11. The first connecting device is attached both to a digital signal processor 13 and to a memory means 14. The digital signal processor 13 and the memory means 14 are also attached to a second connecting device 15 by means of bi-directional communication lines (shown for all lines by means of two directional arrows). The second connecting device can be attached by means of an output line 16 to a data transmit/receive device which is to receive data from the host device or from which data is to be read, i.e. acquired, and transferred to the host device. The data transmit/receive device itself can also communicate actively with the host device via the first and second connecting device, as described in more detail in the following.

Communication between the host system or host device and the interface device is based on known standard access commands as supported by all known operating systems (e.g. DOS, Windows, Unix). Preferably, the interface device according to the present invention simulates a hard disk with

US 6,895,449 B2

5

a root directory whose entries are "virtual" files which can be created for the most varied functions. When the host device system with which the interface device according to the present invention is connected is booted and a data transmit/receive device is also attached to the interface device **10**, usual BIOS routines or multi-purpose interface programs issue an instruction, known by those skilled in the art as the INQUIRY instruction, to the input/output interfaces in the host device. The digital signal processor **13** receives this inquiry instruction via the first connecting device and generates a signal which is sent to the host device (not shown) again via the first connecting device **12** and the host line **11**. This signal indicates to the host device that, for example, a hard disk drive is attached at the interface to which the INQUIRY instruction was sent. Optionally, the host device can send an instruction, known by those skilled in the art as "Test Unit Ready", to the interface device to request more precise details regarding the queried device.

Regardless of which data transmit/receive device at the output line **16** is attached to the second connecting device, the digital signal processor **13** informs the host device that it is communicating with a hard disk drive. If the host device receives the response that a drive is present, it then sends a request to the interface device **10** to read the boot sequence which, on actual hard disks, normally resides on the first sectors of the disk. The digital signal processor **13**, whose operating system is stored in the memory means **14**, responds to this instruction by sending to the host device a virtual boot sequence which, in the case of actual drives, includes the drive type, the starting position and the length of the file allocation table (FAT), the number of sectors, etc., known to those skilled in the art. Once the host device has received this data, it assumes that the interface device **10** according to a preferred embodiment of the present invention is a hard disk drive. In reply to an instruction from the host device to display the directory of the "virtual" hard disk drive simulated by the interface device **10** with respect to the host device, the digital signal processor can respond to the host device in exactly the same way as a conventional hard disk would, namely by reading on request the file allocation table or FAT on a sector specified in the boot sequence, normally the first writable sector, and transferring it to the host device, and subsequently by transferring the directory structure of the virtual hard disk. Further, it is possible that the FAT is not read until immediately prior to reading or storing the data of the "virtual" hard disk and not already at initialization.

In a preferred embodiment of the present invention, the digital signal processor **13**, which need not necessarily be implemented as a digital signal processor but may be any other kind of microprocessor, comprises a first and a second command interpreter. The first command interpreter carries out the steps described above whilst the second command interpreter carries out the read/write assignment to specific functions. If the user now wishes to read data from the data transmit/receive device via the line **16**, the host device sends a command, for example "read file xy", to the interface device. As described above, the interface device appears to the host device as a hard disk. The second command interpreter of the digital signal processor now interprets the read command of the host processor as a data transfer command, by decoding whether "xy" denotes, for example, a "real-time input" file, a "configuration" file or an executable file, whereby the same begins to transfer data from the data transmit/receive device via the second connecting device to the first connecting device and via the line **11** to the host device.

6

Preferably, the volume of data to be acquired by a data transmit/receive device is specified in a configuration file described in the following by the user specifying in the said configuration file that a measurement is to last, for example, five minutes. To the host device the "real-time input" file then appears as a file whose length corresponds to the anticipated volume of data in those five minutes. Those skilled in the art know that communication between a processor and a hard disk consists of the processor transferring to the hard disk the numbers of the blocks or clusters or sectors whose contents it wishes to read. By reference to the FAT the processor knows which information is contained in which block. In this case, communication between the host device and the interface device according to the present invention therefore consists of the very fast transfer of block numbers and preferably of block number ranges because a virtual "real-time input" file will not be fragmented. If the host device now wants to read the "real-time input" file, it transfers a range of block numbers to the interface device, whereupon data commences to be received via the second connecting device and data commences to be sent to the host device via the first connecting device.

In addition to the digital signal processor instruction memory, which comprises the operating system of the digital signal processor and can be implemented as an EPROM or EEPROM, the memory means **14** can have an additional buffer for purposes of synchronizing data transfer from the data transmit/receive device to the interface device **10** and data transfer from the interface device **10** to the host device.

Preferably, the buffer is implemented as a fast random access memory or RAM buffer.

Further, from the host device the user can also create a configuration file, whose entries automatically set and control various functions of the interface device **10**, on the interface device **10** which appears to the host device as a hard disk. These settings can be, for example, gain, multiple or sampling rate settings. By creating and editing a configuration file, normally a text file which is simple to understand with little prior knowledge, users of the interface device **10** are able to perform essentially identical operator actions for almost any data transmit/receive devices which can be attached to the second connecting device via the line **16**, thus eliminating a source of error arising from users having to know many different command codes for different applications. In the case of the interface device **10** according to the present invention it is necessary for users to note the conventions of the configuration file once only in order to be able to use the interface device **10** as an interface between a host device and almost any data transmit/receive device.

As a result of the option of storing any files in agreed formats in the memory means **14** of the interface device **10**, taking into account the maximum capacity of the memory means, any enhancements or even completely new functions of the interface device **10** can be quickly implemented. Even files executable by the host device, such as batch files or executable files (BAT or EXE files), and also help files can be implemented in the interface device, thus achieving independence of the interface device **10** from any additional software (with the exception of the BIOS routines) of the host device. On the one hand, this avoids licensing and/or registration problems and, on the other hand, installation of certain routines which can be frequently used, for example an FFT routine to examine acquired time-domain data in the frequency domain, is rendered unnecessary as the EXE files are already installed on the interface device **10** and appear in the virtual root directory, by means of which the host device can access all programs stored on the interface device **10**.

US 6,895,449 B2

7

In a preferred embodiment of the present invention in which the interface device **10** simulates a hard disk to the host device, the interface device is automatically detected and readied for operation when the host system is powered up or booted. This corresponds to the plug-and-play standard which is currently finding increasingly widespread use. The user is no longer responsible for installing the interface device **10** on the host device by means of specific drivers which must also be loaded; instead the interface device **10** is automatically readied for operation when the host system is booted.

For persons skilled in the art it is however obvious that the interface device **10** is not necessarily signed on when the computer system is powered up but that a special BIOS routine or a driver for a multi-purpose interface can also be started on the host device during current operation of the computer system in order to sign on or mount the interface device **10** as an additional hard disk. This embodiment is suitable for larger workstation systems which are essentially never powered down as they perform, e.g. mail functions or monitor processes which run continuously, for example, in multi-tasking environments.

In the interface device according to the present invention an enormous advantage is to be gained, as apparent in the embodiment described in the following, in separating the actual hardware required to attach the interface device **10** to the data transmit/receive device from the communication unit, which is implemented by the digital signal processor **13**, the memory means **14** and the first connecting device **12**, as this allows a plurality of dissimilar device types to be operated in parallel in identical manner. Accordingly, many interface devices **10** can be connected to a host device which then sees many different "virtual" hard disks. In addition, any modification of the specific hardware symbolized by the second connecting device **15** can be implemented essentially without changing the operation of the interface device according to the present invention. Further, an experienced user can intervene at any time on any level of the existing second connecting device by making use of the above mentioned option of creating a configuration file or adding or storing new program sections for the second connecting device.

An important advantage of the interface device **10** of the present invention is that it also permits extremely high data transfer rates by using, for data interchange, the host device-own BIOS routines which are optimized for each host device by the host device manufacturer or BIOS system manufacturer, or by using driver programs which are normally optimized and included by the manufacturers of multi-purpose interfaces. Furthermore, due to the simulation of a virtual mass storage device, the data is managed and made available in such a way that it can be transferred directly to other storage media, e.g. to an actual hard disk of the host device without, as it were, intervention of the host device processor. The only limitation to long-term data transfer at high speed is therefore imposed exclusively by the speed and the size of the mass storage device of the host device. This is the case as the digital signal processor **13** already formats the data read by the data transmit/receive device via the second connecting device **15** into block sizes suitable for a hard disk of the host device, whereby the data transfer speed is limited only by the mechanical latency of the hard disk system of the host device. At this point, it should be noted that normally data flow from a host device must be formatted in blocks to permit writing to a hard disk and subsequent reading from a hard disk, as known by those skilled in the art.

8

The said data transfer rate can be increased further by setting up a direct memory access (DMA) or RAM drive in the host system. As those skilled in the art know, the setting up of a RAM drive requires processor resources of the host device, with the result that the advantage of writing the data to a hard disk drive of the host device essentially without the need for processor resources is lost.

As described above, a data buffer can be implemented in the memory means **14** to permit independence in terms of time of the data transmit/receive device attached to the second connecting device from the host device attached to the first connecting device. This guarantees error-free operation of the interface device **10** even for time-critical applications in multi-tasking host systems.

FIG. 2 shows a detailed block diagram of an interface device **10** according to the present invention.

A digital signal processor (DSP) **1300** is, in a manner of speaking, the heart of the interface device **10**. The DSP can be any DSP but preferably has a 20-MB on-chip random access memory (RAM). Certain instruction sets, for example, can be stored in the RAM already integrated in the DSP. An 80-MHz clock generator is attached to the DSP **1300** in order to synchronize the DSP. The DSP implements a fast Fourier transformation (FFT) in real time and also optional data compression of the data to be transferred from the data transmit/receive device to the host device in order to achieve greater efficiency and to permit interoperation with host devices which have a smaller memory.

In the preferred embodiment of the interface device **10** shown in FIG. 2, the first connecting device **12** of FIG. 1 contains the following components: an SCSI interface **1220** and a 50-pin SCSI connector **1240** for attachment to an SCSI interface present on most host devices or laptops. The SCSI (small computer system interface) interface **1220** translates the data received via the SCSI connector **1240** into data understood by the DSP **1300**, as known by those skilled in the art. Further, the first connecting device **12** comprises an EPP (enhanced parallel port) with a data transfer rate of approx. 1 MBps which delivers a more moderate data transfer rate of 1 MBps by comparison to the data transfer rate of 10 MBps of the SCSI interface. The EPP **1260** is connected to a 25-pin D-shell connector **1280** to permit attachment to a printer interface of a host device for example. Optionally, the first connecting device **12** also comprises a 25-pin connector **1282** which permits the attachment of 8 digital outputs and 8 digital inputs **1284** at a host device.

Preferably, the second connecting device comprises 8 BNC inputs with the calibration relay **1505**, a block **1510** with 8 device amplifiers with an overvoltage protection of ± 75 V, this block being connected in turn to 8 sample/hold (S&H) circuits **1515**. The calibration relays are relays which permit controlled changeover between a test voltage and a calibration reference voltage. Each sample/hold circuit is connected to a corresponding input of an 8-channel multiplexer **1520** which feeds its output signals via a programmable amplifier **1525** into an analog/digital converter (ADC) with 12 bit and 1.25 MHz **1530** and to the DSP **1300**. The ADC **1530** is controlled by means of a 20-bit timer **1535**, as known by persons skilled in the art. The programmable amplifier **1525** and the 8-channel multiplexer **1520** are controlled via an amplifier channel selection circuit **1540** which is in turn controlled by the DSP **1300**.

The complete interface device **10** is supplied with power by an external AC/DC converter **1800** which delivers a digital supply voltage of ± 5 V and is attached to a DC/DC

US 6,895,449 B2

9

converter 1810 which can deliver analog supply voltages of ± 5 V and ± 15 V as required for the interface device 10. Further, the DC/DC converter controls a precision voltage reference 1820 which controls the 8 BNC inputs 1505 and the ADC 1530 as well as a digital/analog converter (DAC) 1830 which permits, via an output amplifier block with 4 output amplifiers 1840 and a 9-pin connector 1850, analog output direct from the DSP 1300 to an output device, e.g. printer device or monitor device, which can be attached via the 9-pin connector 1850, thus providing the option of monitoring the data transferred to the host device or also, for example, of viewing an FFT to obtain rapid and comprehensive data analysis without using processor time of the host device.

In FIG. 2 the memory means 14 of FIG. 1 is implemented by an EPROM 1400 which, in a preferred embodiment of the present invention, contains the operating system of the digital signal processor 1300. A random access memory with an access time of 15 ns and a size of 512 KB or optionally 1024 KB 1420 serves as a data buffer to achieve independence in terms of time of the output line 16 from the output lines 11a, 11b and 11c to the data transmit/receive device and to the host device respectively. As described above, in a preferred embodiment of the present invention the digital signal processor 1300 already contains a 20-KB on-chip RAM 1440 which can store certain instruction sets, functions and also smaller application software units.

The connection, symbolized by the line 16, of the interface device 10 to any data transmit/receive device implements, by means of the blocks 1505–1535, an analog input with a sampling rate of 1.25 MHz and quantization of 12 bits. There are 8 channels with an overvoltage protection of ± 75 V. By means of the programmable amplifier 1525 the channels can be programmed independently of each other in voltage ranges up to a maximum of ± 10 V. Unused channels can be grounded internally to reduce channel intermodulation. The block 1515 is implemented as a monolithic high-precision, high-speed sample/hold amplifier for simultaneous sampling of all channels. The precision voltage reference 1820 provides a high-precision, temperature-compensated monolithic energy gap voltage reference for auto-calibration of each channel and each gain. Further, offset fine adjustment for each channel is implemented by the same.

The blocks 1830, 1840 and 1850 implement a direct analog output for the digital signal processor 1300, and the DAC 1830 provides a data transfer rate of 625 kHz and a quantization of 12 bits. The block 1840 comprises 4 channels with a common output latch.

Further, the interface device 10 comprises a digital input/output device implemented by the blocks 1284 and 1282. Here there are 8 digital inputs, 8 digital outputs with a common latch, and the digital port can be attached preferably to a side panel of the interface device 10 so that the port itself can easily be accessed.

The digital signal processor 1300 provides on-board digital data processing. In particular, it is a high-performance DSP with a clock speed of 80 MHz and a 20-bit timer 1535.

As described above, the first connecting device 12 comprises the SCSI interface 1220 with a peak transfer rate of 10 MBps. An optional PCMCIA-to-SCSI adapter permits high-speed communication with laptop computers which are desirable and in widespread use, particularly by mobile service technicians. The EPP 1260 with its associated connector 1280 permits data transfer at a more moderate rate.

As described above, the interface device 10 is supplied with power by means of an external AC/DC adapter which

10

has a universal power input (85–264 VAC, 47–63 Hz). Interference suppression complies with the standards EN 55022, curve B and FFC, Class B). Further, it is also in accordance with international safety regulations (TÜV, UL, CSA). The interface device 10 is externally shielded and achieves a value of 55 dB at 30–60 MHz and a value of approximately 40 dB at 1 GHz, and therefore complies with the MILSTD 285-1 standard.

As described above, communication between the host device and the multi-purpose interface can take place not only via drivers for input/output device customary in a host device which reside in the BIOS system of the host device but also via specific interface drivers which, in the case of SCSI interfaces, are known as multi-purpose interface ASPI (advanced SCSI programming interface) drivers. This ASPI driver, which can also be referred to as an ASPI manager, is specific to a special SCSI host adapter, i.e. to a special multi-purpose interface, and is normally included by the manufacturer of the multi-purpose interface. Generally speaking, this multi-purpose interface driver has the task of moving precisely specified SCSI commands from the host system program to the host system SCSI adapter. For this reason, the command set is almost identical to that of the SCSI interface itself. Essentially, only status and reset commands for the host adapter have been added.

The ASPI driver can be used if the hard disk was not already addressable at boot time or if the SCSI-related BIOS routines of the host computer were still disabled. Here too, the steps needed to initialize the interface device, preferably as a virtual hard disk, are similar to the steps taken when initializing at boot time.

In general terms, the ASPI manager comprises two sides. One side is the proprietary, hardware-oriented side. It is responsible for converting all commands into a form required by the corresponding multi-purpose interface. The hardware-oriented side of the ASPI driver is therefore matched to a very specific type of multi-purpose interface or SCSI interface. The other side is known as the user software side. This side is totally independent of the proprietary operating characteristics of the SCSI adapter and is therefore identical for all SCSI interfaces. This permits SCSI programming which is however independent of the individual SCSI adapter types.

In contrast to communication between the host device and the interface device according to the present invention on the basis of a BIOS driver, the use of such an ASPI driver for communication between the host device and the interface device according to the present invention allows various further possibilities of the SCSI multi-purpose interface to be exploited. In the case described above, the interface device which preferably signs on and behaves as a virtual hard disk is detected by the BIOS driver of the host computer at boot time and is configured as a hard disk. This step does not however support active requests sent by the interface device to the host computer. If however the virtual hard disk wishes to write data actively to, for example, a hard disk of the host computer or wishes to initiate communication with the processor of the host computer, the host computer must recognize the request of the virtual hard disk and tolerate a further issuer of instructions on its bus. If the interface device behaves solely like a virtual hard disk, it would always receive and never issue commands. The BIOS has no objections to an additional issuer of commands that actively wishes to place data on the bus of the host device but the BIOS does not support the host device in recognizing corresponding requests of the interface device or in granting the interface device permission to access the bus.

US 6,895,449 B2

11

Using the ASPI manager the interface device according to the present invention can now obtain active access to an SCSI hard disk of the host device connected to the same SCSI bus which, in contrast to the interface device, cannot be a virtual but a real SCSI mass storage device or also a further interface device according to the present invention. Thereupon, the interface device according to the present invention can write the desired data to the SCSI hard disk of the host computer totally independently of the host computer or can communicate with the same in some other manner. The interface device according to the present invention therefore initially behaves passively as a virtual hard disk and then, as required and using the driver software for the multi-purpose interface, actively on the same SCSI bus. This means however that the interface device according to the present invention, using a driver software for the multi-purpose interface which comprises the BIOS routines customary in host devices and simultaneously provides the option of active participation, can, regardless of the type of the data transmit/receive device attached to the second connecting device, behave initially as a virtual and at the same time passive hard disk but can, as required, participate actively on the bus so as to be able to initiate communication directly with other SCSI hard disks of the host device by bypassing the processor of the host device.

Using a standard interface of a host device, the interface device according to the present invention permits communication with any host device. By simulating an input/output device to the host device and, in a preferred embodiment, by simulating a virtual mass storage device, the interface device 10 is automatically supported by all known host systems without any additional sophisticated driver software. The simulation of a freely definable file structure on the "virtual" hard disk provides simple operation and expansion options and, through the implementation of any programs, independence from special software implemented on the host device. Help files included on the interface device 10 and plug-and-play support ensure ease of use even in portable, flexible host devices. Despite the very simple user interface, experienced users are free at any time to intervene in the functions of the interface device 10 on system level. The interface device 10 thus provides a universal solution which can cover the entire spectrum of possible data transmit/receive devices.

What is claimed is:

1. An interface device for communication between a host device, which comprises drivers for input/output devices customary in a host device and a multi-purpose interface, and a data transmit/receive device comprising the following features:

- a processor;
- a memory;
- a first connecting device for interfacing the host device with the interface device via the multi-purpose interface of the host device; and
- a second connecting device for interfacing the interface device with the data transmit/receive device,

wherein the interface device is configured by the processor and the memory in such a way that the interface device, when receiving an inquiry from the host device as to the type of a device attached to the multi-purpose interface of the host device, sends a signal, regardless of the type of the data transmit/receive device attached to the second connecting device of the interface device, to the host device which signals to the host device that it is a storage device customary in a host device,

12

whereupon the host device communicates with the interface device by means of the driver for the storage device customary in a host device, and

wherein the interface device is arranged for simulating a virtual file system to the host, the virtual file system including a directory structure.

2. An interface device in accordance with claim 1, in which the directory structure has a configuration file for setting and controlling functions of the interface device or an executable or a batch file for conducting a routine stored in the memory or a data file used for transferring data from the data transmit/receive device to the host device or a help file for giving help on handling the interface device.

3. An interface device in accordance with claim 2 wherein the configuration file is a text file.

4. An interface device in accordance with claim 2 wherein the executable file includes a Fast Fourier Transform routine for transforming data acquired by the second connecting device into the frequency domain and for examining frequency domain data.

5. An interface device in accordance with claim 2 wherein the executable file includes a data compression routine for compressing data to be transmitted from the data transmit/receive device to the host device.

6. An interface device in accordance with claim 1 wherein, in response to a request from the host to read a boot sequence, the processor is arranged to send a virtual boot sequence to the host.

7. An interface device in accordance with claim 6 wherein the virtual boot sequence includes a starting position and a length of a file allocation table, an indication of a type of the storage device or a number of sectors of the storage device.

8. An interface device in accordance with claim 7 wherein, in response to a request from the host to display a directory of the storage device, a processor is arranged for transferring the file allocation table and the directory structure to the host.

9. An interface device in accordance with claim 1 wherein the file allocation table and the directory structure is transferred to the host in response to a request from the host to read data from or store data to the storage device.

10. An interface device in accordance with claim 1 wherein the directory structure includes a data file for transferring data from the data transmit/receive device to the host device wherein the processor is arranged to interpret a request from the host to read the data file as a request for a data transfer from the data transmit/receive device to the host, so that data is transmitted from the second connecting device to the first connecting device and to the host.

11. An interface device in accordance with claim 10 wherein the directory structure further includes a configuration file for specifying a time period for a measurement by the data transmit/receive device, wherein the interface device is arranged for simulating a length of the data file to the host that corresponds to an anticipated volume of data produced by the data transmit/receive device in the specified time period.

12. An interface device in accordance with claim 1 wherein the file allocation table includes information on numbers of blocks occupied by the data file wherein the interface device is arranged for receiving block numbers or a block number range from the host when the host wants to read the data file, and wherein the interface device is arranged to start a data transfer to the host, when the block numbers or the block number range is received from the host.

13. An interface device in accordance with claim 12 wherein the processor is arranged for formatting the data

US 6,895,449 B2

13

acquired by the second connecting device into blocks having a predetermined size, the predetermined size being suited for the storage device.

14. An interface device in accordance with claim 1 wherein the functions are gain, multiplex or synchronization settings of the second connecting device.

15. An interface device in accordance with claim 1 wherein the storage device is a hard disk.

16. An interface device in accordance with claim 1 wherein the memory has a data buffer for permitting independence in terms of time of the data transmit/receive device attachable to the second connecting device from the host device attachable to the first connecting device.

17. An interface device for communication between a host device, which comprises a multi-purpose interface and a specific driver for this interface, and a data transmit/receive device comprising the following features:

- a processor;
- a memory;
- a first connecting device for interfacing the host device with the interface device via the multi-purpose interface of the host device; and
- a second connecting device for interfacing the interface device with the data transmit/receive device,

where the interface device is configured using the processor and the memory in such a way that the interface device, when receiving an inquiry from the host device as to the type of a device attached at the multi-purpose interface of the host device, sends a signal, regardless of the type of the data transmit/receive device attached to the second connecting device of the interface device, to the host device which signals to the host device that it is a storage device customary in a host device,

14

whereupon the host device communicates with the interface device by means of the specific driver for the multi-purpose interface, and

wherein the interface device is arranged for simulating a virtual file system to the host, the virtual file system including a file allocation table and a directory structure.

18. A method of communication between a host device, which comprises drivers for input/output devices customary in a host device and a multi-purpose interface, and a data transmit/receive device via an interface device comprising the following steps:

interfacing of the host device with a first connecting device of the interface device via the multi-purpose interface of the host device;

interfacing of the data transmit/receive device with a second connecting device of the interface device;

inquiring by the host device at the interface device as to the type of device to which the multi-purpose interface of the host device is attached;

regardless of the type of the data transmit/receive device attached to the second connecting device of the interface device, responding to the inquiry from the host device by the interface device in such a way that it is a storage device customary in a host device, whereupon the host device communicates with the interface device by means of the usual driver for the storage device, and wherein the interface device is arranged for simulating a virtual file system to the host, the virtual file system including a file allocation table and a directory structure.

* * * * *

CERTIFICATE OF SERVICE

I hereby certify that all counsel of record who have consented to electronic service are being served with a copy of the foregoing document via the Court's CM/ECF system. The document was also sent via electronic mail to:

Steven J. Routh
ORRICK, HERRINGTON & SUTCLIFFE LLP
Columbia Center
1152 15th Street, N.W.
Washington, DC 20005
Direct: 202-339-8509
Fax: 202-339-8500
Email: srouth@orrick.com

John R. Inge
ORRICK, HERRINGTON & SUTCLIFFE LLP
Izumi Garden Tower, 28th Floor
6-1 Roppongi 1-Chome
Minato-ku
+81332242900
+81332242901
Email: jinge@orrick.com

Sten Jensen
ORRICK, HERRINGTON & SUTCLIFFE LLP
Columbia Center
1152 15th Street, N.W.
Washington, DC 20005
Direct: 202-339-8669
Fax: 202-339-8500
Email: sjensen@orrick.com

T. Vann Pearce, Jr.
ORRICK, HERRINGTON & SUTCLIFFE LLP
Columbia Center
1152 15th Street, N.W.
Washington, DC 20005
Direct: 202-339-8696
Fax: 202-339-8500
Email: vpearce@orrick.com

Rachel M. Capoccia
ALSTON & BIRD LLP
333 South Hope Street
16th Floor
Los Angeles, CA 90071
Direct: 213-576-1037
Email: rachel.capoccia@alston.com
Fax: 213-576-1100

Thomas W. Davison
ALSTON & BIRD LLP
950 F Street, N.W.
Washington, DC 20004
Direct: 202-239-3933
Email: tom.davison@alston.com

Charlene M. Morrow
FENWICK & WEST, LLP
801 California Street
Silicon Valley Center
Mountain View, CA 94041
Direct: 650-988-8500
Email: cmorrow@fenwick.com

Bryan Alexander Kohm
FENWICK & WEST, LLP
555 California Street
12th Floor
San Francisco, CA 94104
Direct: 415-875-2300
Fax: 415-281-1350
Email: bkohm@fenwick.com

David Douglas Schumann
FENWICK & WEST, LLP
555 California Street
12th Floor
San Francisco, CA 94104
Direct: 415-875-2300
Fax: 415-281-1350
Email: dschumann@fenwick.com

Richard de Bodo
BINGHAM MCCUTCHEN LLP
1601 Cloverfield Boulevard
The Water Garden
Suite 2050 North
Santa Monica, CA 90404
Direct: 310-907-1000
Fax: 310-907-2000
Email: rich.debodo@bingham.com

Andrew V. Devkar
BINGHAM MCCUTCHEN LLP
Suite 2050 North
1601 Cloverfield Boulevard
The Water Garden
Suite 2050 North
Santa Monica, CA 90404
Direct: 310-907-1000
Fax: 310-907-2000
Email: andrew.devkar@bingham.com

Patrick J. Kelleher
DRINKER BIDDLE & REATH LLP
191 N. Wacker Drive
Suite 3700
Chicago, IL 60606
Direct: 312-569-1000
Fax: 312-569-3000
Email: patrick.kelleher@dbr.com

David L. Witcoff
JONES DAY
Suite 3500
77 West Wacker Drive
Chicago, IL 60601-1692
Direct: 312-269-4259
Email: dlwitcoff@jonesday.com

Marc Blackman
JONES DAY
Suite 3500
77 West Wacker Drive
Chicago, IL 60601-1692
Direct: 312-782-3939
Fax: (312) 782-8585
Email: msblackman@jonesday.com

Marron Ann Mahoney
JONES DAY
77 West Wacker Drive
Chicago, IL 60601-1692
Direct: 312-269-4291
Email: mmahoney@jonesday.com

February 20, 2014

/s/ John T. Battaglia
John T. Battaglia

CERTIFICATE OF COMPLIANCE

Pursuant to Federal Rule of Appellate Procedure 32(a)(7)(c), the undersigned certifies that this brief complies with the applicable type-volume limitations.

Exclusive of the portions exempted by Federal Rule of Appellate Procedure 32(a)(7)(B)(iii) and Circuit Rule 32(b), this brief contains 13,936 words. This certificate was prepared in reliance on the word count of the word processing system Microsoft Word 2010 used to prepare this brief.

This brief further complies with the typeface requirements of Federal Rule of Appellate Procedure 32(a)(5) and the type style requirements of Federal Rule of Appellate Procedure 32(a)(6). The brief has been prepared in a proportionally spaced typeface using Microsoft Word Version 2010 in 14 point Times New Roman font.

/s/ John T. Battaglia
John T. Battaglia