

[54] COMPUTER SYSTEM WITH AUTOMATIC INITIALIZATION OF PLUGGABLE OPTION CARDS

3508648 9/1986 Fed. Rep. of Germany .
50-120935 9/1976 Japan .

(List continued on next page.)

[75] Inventors: Chester A. Heath; John K. Langgood, both of Boca Raton, Fla.; Ronald E. Valli, Pittsburgh, Pa.

OTHER PUBLICATIONS

IBM TDB vol. 20, No. 7, Dec. 1977, Input/Output Device Address Recognition Mechanism.

(List continued on next page.)

[73] Assignee: International Business Machines Corp., Armonk, N.Y.

[21] Appl. No.: 296,387

[22] Filed: Jan. 6, 1989

Primary Examiner—Gareth D. Shaw
Assistant Examiner—Paul Kulik
Attorney, Agent, or Firm—Winfield J. Brown, Jr.; Robert Lieber

Related U.S. Application Data

[63] Continuation of Ser. No. 21,391, Mar. 13, 1987, abandoned.

[51] Int. Cl.⁵ G06F 13/00; G06F 7/04

[52] U.S. Cl. 364/900; 364/948.5; 364/944.61; 364/975.2; 364/976.4; 364/945; 364/929.5; 364/929.2; 371/11.1

[58] Field of Search ... 364/200 MS File, 900 MS File; 340/825.07, 825.06, 825.52, 825.06; 371/11.1, 11.2, 11.3, 66, 7

[57] ABSTRACT

A data processing system includes a planar board having a central processing unit (CPU), a main memory unit, and input/output (I/O) sockets or slots, each adapted to receive a selected one of a plurality of different and/or similar option cards. Each card contains (or is connected to) and controls a respective peripheral device; and each card is pre-wired with an ID value corresponding to its card type. Software programmable option registers on each card store parameters such as designated default (or alternate) address information, priority levels, and other system resource parameters. A setup routine, during initial power-on, retrieves and stores the appropriate parameters in the I/O cards and also in slot positions in main memory, one position being assigned to each slot on the board. Each slot position is adapted to hold the parameters associated with the card inserted in its respective slot and the card ID value. That portion of main memory containing the slot positions is adapted to maintain the parameter and ID information by means of battery power when system power fails or is disconnected, i.e., a nonvolatile memory portion. Subsequent power-on routines are simplified by merely transferring parameters from the table to the card option registers if the status of all the slots has not changed since the last power-down, system reset, or channel reset.

[56] References Cited

U.S. PATENT DOCUMENTS

3,480,914	11/1969	Schlaeppli	364/200
3,510,843	5/1970	Bennett	364/200
3,573,741	4/1971	Gavril	364/200
3,818,447	6/1974	Craft	340/172.5
4,003,033	1/1977	O'Keefe	364/200
4,015,244	3/1977	Simpson	364/200

(List continued on next page.)

FOREIGN PATENT DOCUMENTS

0041406	9/1981	European Pat. Off.
0087368	8/1983	European Pat. Off.
0121331	3/1984	European Pat. Off.
0121381	10/1984	European Pat. Off.
0136178	4/1985	European Pat. Off.
0179981	6/1985	European Pat. Off.
0171073	2/1986	European Pat. Off.
0182044	5/1986	European Pat. Off.
0200198	11/1986	European Pat. Off.

18 Claims, 7 Drawing Sheets

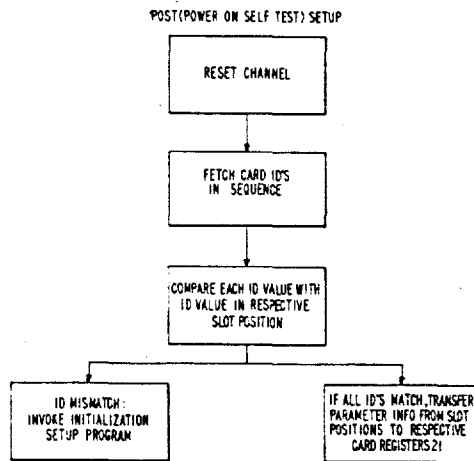

U.S. PATENT DOCUMENTS

4,025,903	5/1977	Kaufman	364/200
4,027,108	5/1977	Moorehead	
4,070,704	1/1978	Calle et al.	364/200
4,075,693	2/1978	Fox	364/200
4,155,117	5/1979	Mitchell, Jr.	364/200
4,177,511	12/1979	Taddei	364/200
4,191,996	3/1980	Chesley	364/200
4,236,207	11/1980	Rado	364/200
4,253,087	2/1981	Saal	340/147 R
4,253,144	2/1981	Bellamy	364/200
4,254,463	3/1981	Busby	364/200
4,268,901	5/1981	Subrizi	364/200
4,293,924	10/1981	Struger	364/900
4,303,993	12/1981	Panepinto	365/230
4,314,354	2/1982	Felder	364/900
4,335,426	6/1982	Maxwell	364/200
4,356,475	10/1982	Neumann	340/521
4,360,870	11/1982	McVey	364/200
4,363,094	12/1982	Kaul	364/200
4,373,181	2/1983	Chisholm et al.	364/200
4,400,775	8/1983	Nozaki	364/200
4,432,049	2/1984	Shaw et al.	364/200
4,437,157	3/1984	Witalka	364/200
4,442,504	4/1984	Dummermuth	364/900
4,454,596	6/1984	Wunsch	364/900
4,458,357	7/1984	Weymouth	377/2
4,491,913	1/1985	Calvignac	364/200
4,514,728	4/1985	Ahuja	340/825.5
4,521,847	6/1985	Ziehm et al.	371/7 X
4,556,953	12/1985	Caprio et al.	364/900
4,562,535	12/1985	Vincent et al.	364/200
4,563,736	1/1986	Boudreau	364/200
4,571,676	2/1986	Mantellina	364/200
4,578,773	3/1986	Desai	364/900
4,589,063	5/1986	Shah et al.	364/200
4,604,690	8/1986	Crabtree et al.	364/200
4,622,633	11/1986	Ceccon et al.	364/200
4,626,634	12/1986	Brahm	379/28
4,633,392	12/1986	Vincent	364/200
4,654,857	3/1987	Samson	371/68
4,660,141	4/1987	Ceccon	364/200
4,670,855	6/1987	Caprio	364/900
4,701,878	10/1987	Günkel et al.	364/900
4,713,834	12/1987	Brahm	379/28
4,718,038	1/1988	Yoshida	364/900
4,750,136	6/1988	Arpin et al.	364/200 X
4,760,553	7/1988	Buckley et al.	364/900
4,787,025	11/1988	Cheselka	364/200
4,787,028	11/1988	Finfrock et al.	364/900 X
4,787,030	11/1988	Harter	364/200
4,870,704	9/1989	Matelan	364/200

FOREIGN PATENT DOCUMENTS

54-24314	3/1979	Japan
54-73531	6/1979	Japan

55-56235	4/1980	Japan
56-46384	10/1982	Japan
2101370	1/1983	United Kingdom
2137382	10/1984	United Kingdom
2166893	5/1986	United Kingdom
2175716	12/1986	United Kingdom

OTHER PUBLICATIONS

- IBM TDB vol. 20, No. 8, Jan. 1978, Initial Microprogram Load by Blocks Via Cycle Steal.
- IBM TDB vol. 22, No. 2, Jul., 1979, Even/Odd Addresses to Allow Device Adapter Sharing by More Than One Processor.
- IBM TDB vol. 22, No. 5, Oct. 1979, Satellite Station Address Assignment Method.
- IBM TDB vol. 22, No. 10, Mar., 1980, Automatic Module Detection.
- IBM TDB vol. 23, No. 8, Jan., 1981, Dynamic Device Address Assignment Mechanism.
- Electronic Design, Sep. 3, 1981, pp. 141-156, Several Articles, "Functional Architecture Threatens Central CPUs", etc.
- Paper in Euromicro, Input/Output Control of IBM System/370 Model 125 through Dedicated Input/Output Processors, by Assmuth et al., pp. 24-40.
- Technical Disclosure Bulletin (IBM) vol. 27, No. 1E "Automatic Domain Configuration Mechanism for a Multi-Device I/O Controller".
- Wescon Technical Paper Oct. 30-Nov. 2, 1984, "A Standard Protocol for Host Computer-Peripheral Interface Allows Upgrading to the Latest Mass Storage Devices".
- Technical Disclosure Bulletin (IBM) vol. 27, No. 2, Jul 1984 "Input/Output Channel Address Assignment Mechanism".
- JP Abstract vol. 10, No. 256 (P-493) (23312) Sep. 2 1986.
- JP Abstract vol. 9, No. 239 (P-391) (1962) Sep. 25 1985.
- JP Abstract vol. 9, vol. 9, No. 190 (P-378) (1913) Aug 7, 1985.
- EDN Magazine vol. 26 (1981) Feb., No. 3, Boston, MA
- New Electronics 19(1986) Jul., No. 14, London, Great Britain.
- vol. 22, No. 3, Aug. 1979, IBM Technical Disclosure Bulletin, Programmable Identification for I/O Device J. M. McVey.
- vol. 16, No. 1 Jun. 1973, IBM Technical Disclosure Bulletin, Program Controlled I/O Address Assignment L. J. Rosenberg.

FIG. 1

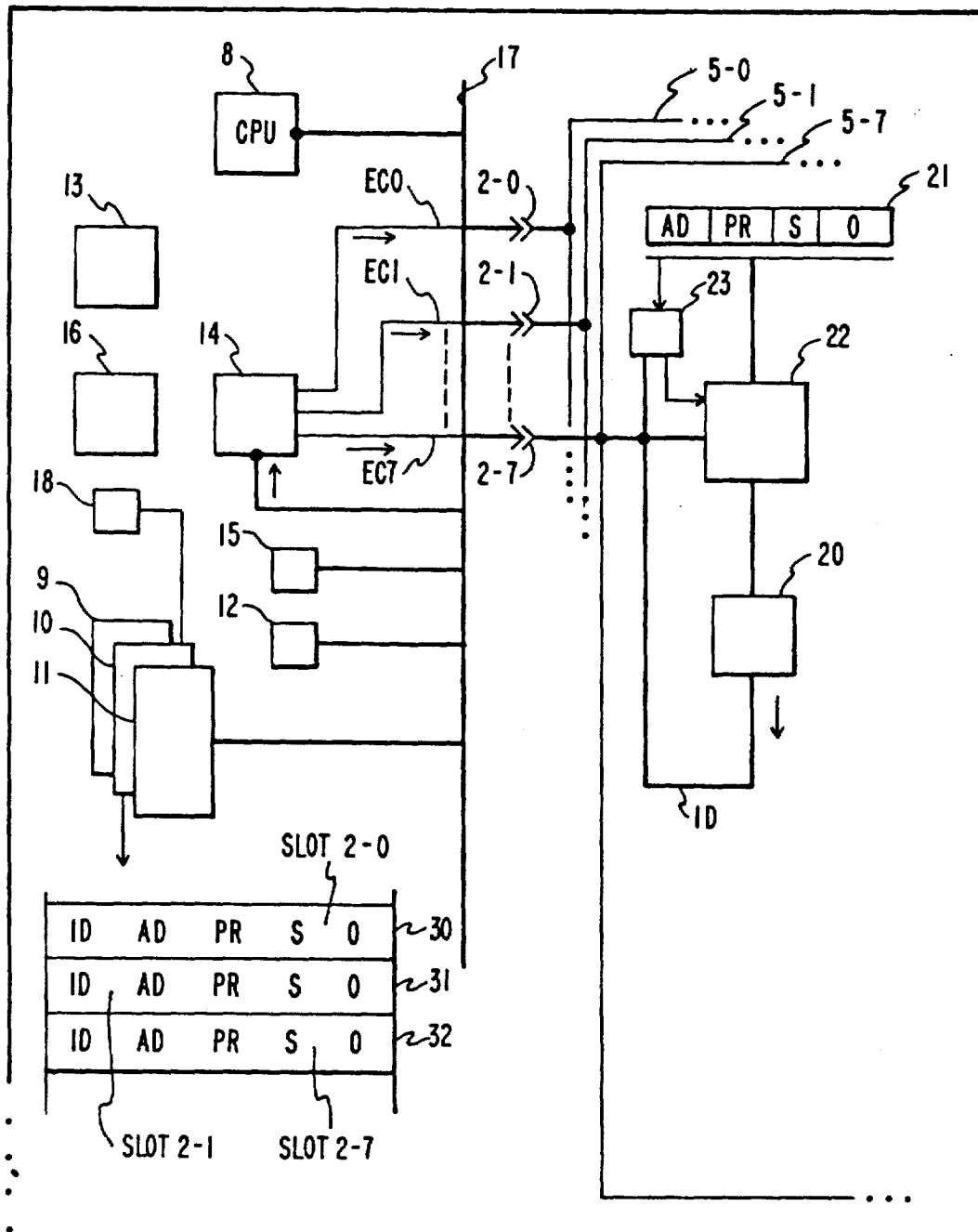
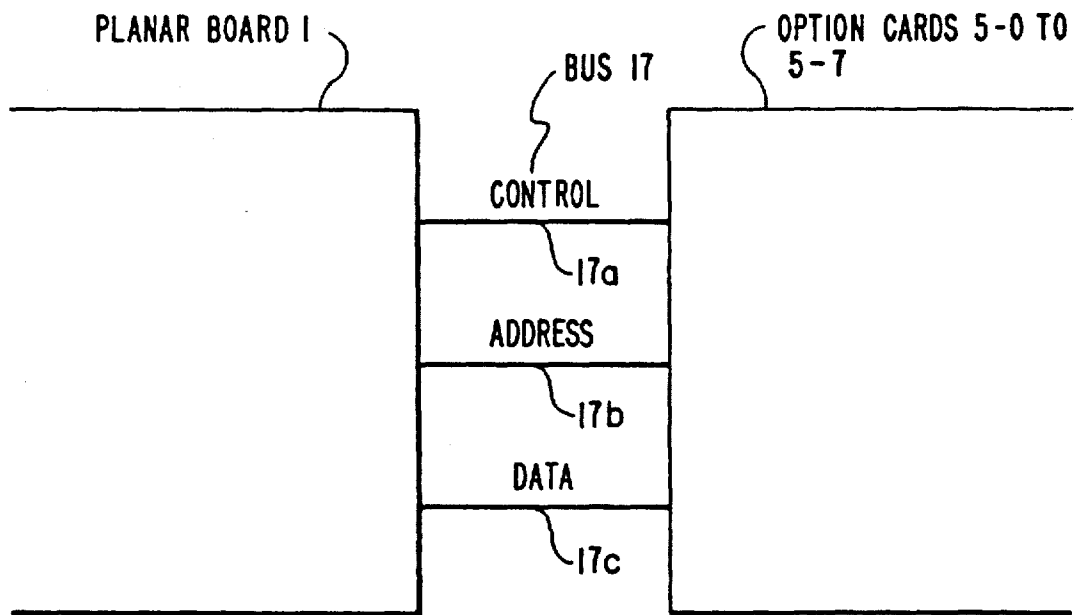
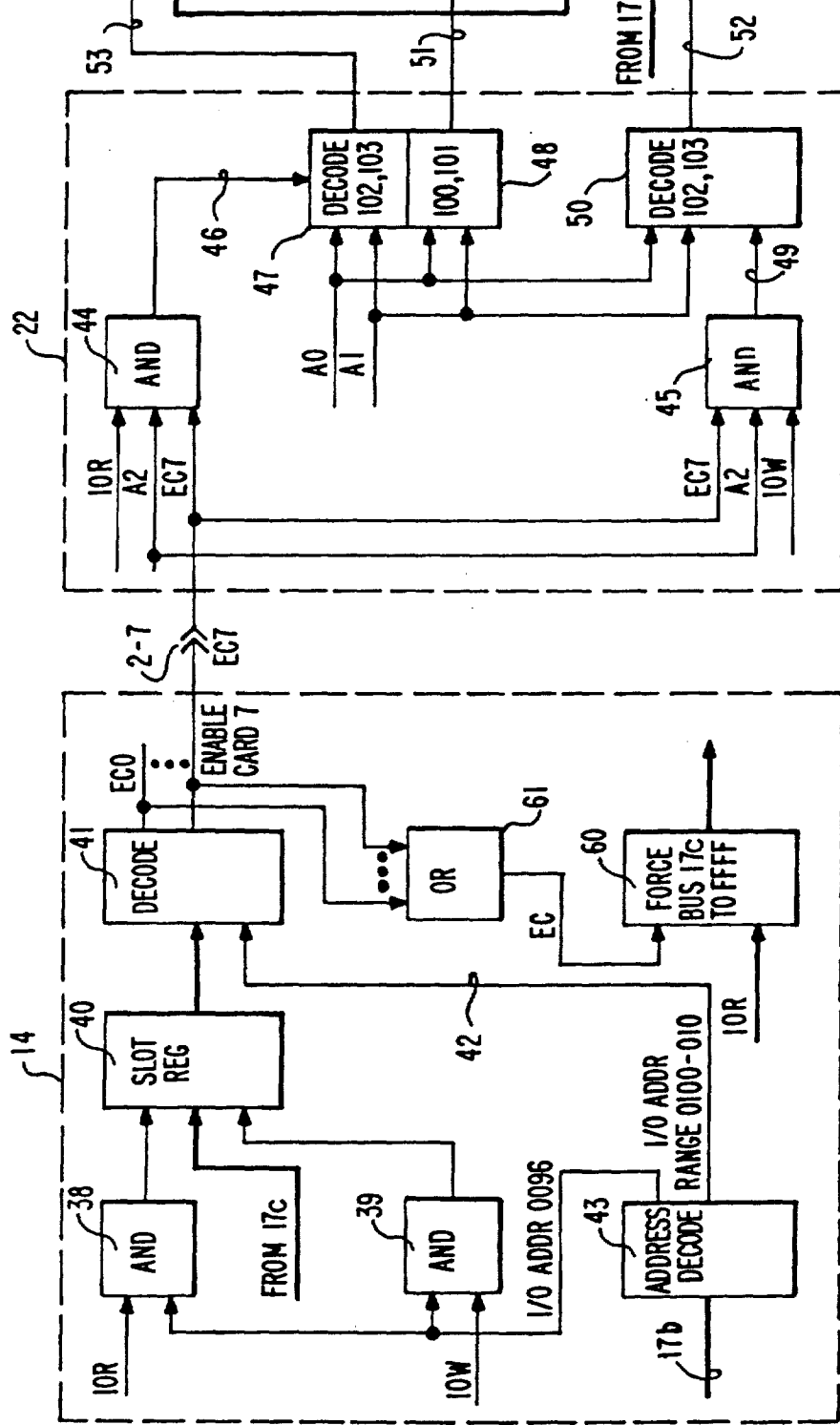

FIG. 2





Explore Litigation Insights

Docket Alarm provides insights to develop a more informed litigation strategy and the peace of mind of knowing you're on top of things.

Real-Time Litigation Alerts



Keep your litigation team up-to-date with **real-time alerts** and advanced team management tools built for the enterprise, all while greatly reducing PACER spend.

Our comprehensive service means we can handle Federal, State, and Administrative courts across the country.

Advanced Docket Research



With over 230 million records, Docket Alarm's cloud-native docket research platform finds what other services can't. Coverage includes Federal, State, plus PTAB, TTAB, ITC and NLRB decisions, all in one place.

Identify arguments that have been successful in the past with full text, pinpoint searching. Link to case law cited within any court document via Fastcase.

Analytics At Your Fingertips



Learn what happened the last time a particular judge, opposing counsel or company faced cases similar to yours.

Advanced out-of-the-box PTAB and TTAB analytics are always at your fingertips.

API

Docket Alarm offers a powerful API (application programming interface) to developers that want to integrate case filings into their apps.

LAW FIRMS

Build custom dashboards for your attorneys and clients with live data direct from the court.

Automate many repetitive legal tasks like conflict checks, document management, and marketing.

FINANCIAL INSTITUTIONS

Litigation and bankruptcy checks for companies and debtors.

E-DISCOVERY AND LEGAL VENDORS

Sync your system to PACER to automate legal marketing.