

**NEAR SHANNON LIMIT ERROR - CORRECTING
CODING AND DECODING : TURBO-CODES (1)**

Claude Berrou, Alain Glavieux and Punya Thitimajshima

Claude Berrou, Integrated Circuits for Telecommunication Laboratory

Alain Glavieux and Punya Thitimajshima, Digital Communication Laboratory

Ecole Nationale Supérieure des Télécommunications de Bretagne, France

(1) Patents N° 9105279 (France), N° 92460011.7 (Europe), N° 07/870,483 (USA)

Abstract - This paper deals with a new class of convolutional codes called *Turbo-codes*, whose performances in terms of Bit Error Rate (BER) are close to the SHANNON limit. The *Turbo-Code* encoder is built using a parallel concatenation of two Recursive Systematic Convolutional codes and the associated decoder, using a feedback decoding rule, is implemented as *P* pipelined identical elementary decoders.

I - INTRODUCTION

Consider a binary rate $R=1/2$ convolutional encoder with constraint length K and memory $M=K-1$. The input to the encoder at time k is a bit d_k and the corresponding codeword C_k is the binary couple (X_k, Y_k) with

$$X_k = \sum_{i=0}^{K-1} g_{1i} d_{k-i} \quad \text{mod.2} \quad g_{1i} = 0,1 \quad (1a)$$

$$Y_k = \sum_{i=0}^{K-1} g_{2i} d_{k-i} \quad \text{mod.2} \quad g_{2i} = 0,1 \quad (1b)$$

where $G_1: \{g_{1i}\}$, $G_2: \{g_{2i}\}$ are the two encoder generators, generally expressed in octal form.

It is well known, that the BER of a classical Non Systematic Convolutional (NSC) code is lower than that of a classical Systematic code with the same memory M at large SNR. At low SNR, it is in general the other way round. The new class of Recursive Systematic Convolutional (RSC) codes, proposed in this paper, can be better than the best NSC code at any SNR for high code rates.

A binary rate $R=1/2$ RSC code is obtained from a NSC code by using a feedback loop and setting one of the two outputs X_k or Y_k equal to the input bit d_k . For an RSC code, the shift register (memory) input is no longer the bit d_k but is a new binary variable a_k . If $X_k=d_k$ (respectively $Y_k=d_k$), the output Y_k (resp. X_k) is equal to equation (1b) (resp. 1a) by substituting a_k for d_k and the variable a_k is recursively calculated as

$$a_k = d_k + \sum_{i=1}^{K-1} \gamma_i a_{k-i} \quad \text{mod.2} \quad (2)$$

where γ_i is respectively equal to g_{1i} if $X_k=d_k$ and to g_{2i} if $Y_k=d_k$. Equation (2) can be rewritten as

$$d_k = \sum_{i=0}^{K-1} \gamma_i a_{k-i} \quad \text{mod.2.} \quad (3)$$

One RSC encoder with memory $M=4$ obtained from an NSC encoder defined by generators $G_1=37$, $G_2=21$ is depicted in Fig.1.

Generally, we assume that the input bit d_k takes values 0 or 1 with the same probability. From equation (2), we can show that variable a_k exhibits the same statistical property

$P_r\{a_k = 0 / a_1 = \epsilon_1, \dots, a_{k-1} = \epsilon_{k-1}\} = P_r\{d_k = \epsilon\} = 1/2$ (4)
with ϵ is equal to

$$\epsilon = \sum_{i=1}^{K-1} \gamma_i \epsilon_i \quad \text{mod.2} \quad \epsilon = 0,1. \quad (5)$$

Thus the trellis structure is identical for the RSC code and the NSC code and these two codes have the same free distance d_f . However, the two output sequences $\{X_k\}$ and $\{Y_k\}$ do not correspond to the same input sequence $\{d_k\}$ for RSC and NSC codes. This is the main difference between the two codes.

When punctured code is considered, some output bits X_k or Y_k are deleted according to a chosen puncturing pattern defined by a matrix P . For instance, starting from a rate $R=1/2$ code, the matrix P of rate $2/3$ punctured code is

$$P = \begin{bmatrix} 1 & 1 \\ 1 & 0 \end{bmatrix}$$

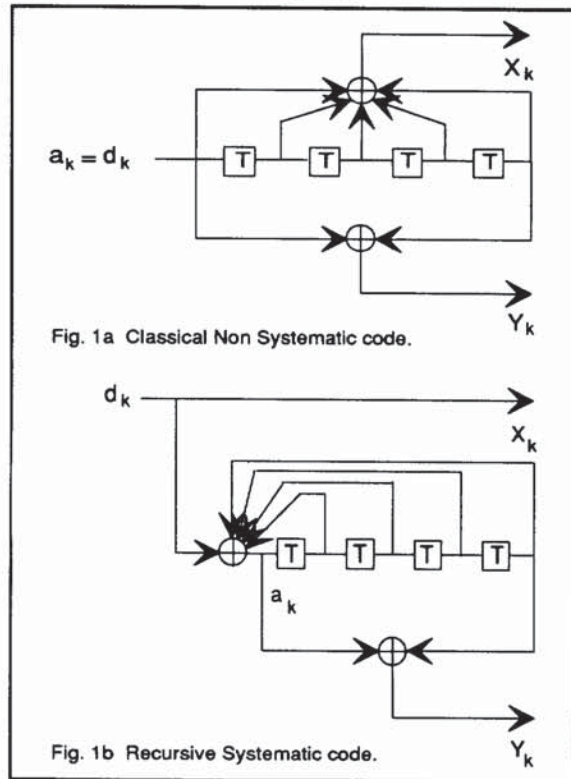

Fig. 1a Classical Non Systematic code.

Fig. 1b Recursive Systematic code.

II - PARALLEL CONCATENATION OF RSC CODES

With RSC codes, a new concatenation scheme, called parallel concatenation can be used. In Fig. 2, an example of two identical RSC codes with parallel concatenation is shown. Both elementary encoder (C_1 and C_2) inputs use the same bit d_k but according to a different sequence due to the presence of an interleaver. For an input bit sequence $\{d_k\}$, encoder outputs X_k and Y_k at time k are respectively equal to d_k (systematic encoder) and to encoder C_1 output Y_{1k} , or to encoder C_2 output Y_{2k} . If the coded outputs (Y_{1k}, Y_{2k}) of encoders C_1 and C_2 are used respectively n_1 times and n_2 times and so on, the encoder C_1 rate R_1 and encoder C_2 rate R_2 are equal to

$$R_1 = \frac{n_1 + n_2}{2n_1 + n_2} \quad R_2 = \frac{n_1 + n_2}{2n_2 + n_1} \quad (6)$$

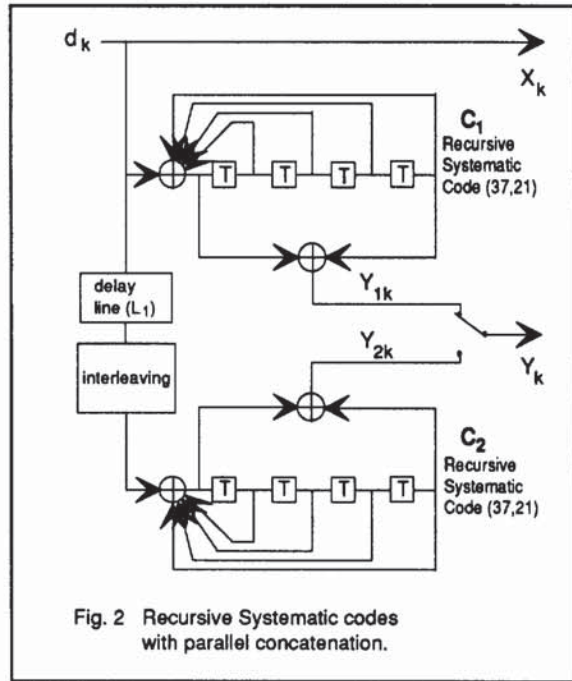

The decoder DEC depicted in Fig. 3a, is made up of two elementary decoders (DEC₁ and DEC₂) in a serial concatenation scheme. The first elementary decoder DEC₁ is associated with the lower rate R_1 encoder C_1 and yields a soft (weighted) decision. The error bursts at the decoder DEC₁ output are scattered by the interleaver and the encoder delay L_1 is inserted to take the decoder DEC₁ delay into account. Parallel concatenation is a very attractive scheme because both elementary encoder and decoder use a single frequency clock.

For a discrete memoryless gaussian channel and a binary modulation, the decoder DEC input is made up of a couple R_k of two random variables x_k and y_k , at time k

$$x_k = (2d_k - 1) + i_k \quad (7a)$$

$$y_k = (2Y_k - 1) + q_k \quad (7b)$$

where i_k and q_k are two independent noises with the same variance σ^2 . The redundant information y_k is demultiplexed and sent to decoder DEC₁ when $Y_k = Y_{1k}$ and toward decoder DEC₂ when $Y_k = Y_{2k}$. When the redundant information of a

given encoder (C_1 or C_2) is not emitted, the corresponding decoder input is set to zero. This is performed by the DEMUX/INSERTION block.

It is well known that soft decoding is better than hard decoding, therefore the first decoder DEC₁ must deliver to the second decoder DEC₂ a weighted (soft) decision. The Logarithm of Likelihood Ratio (LLR), $\Lambda_1(d_k)$ associated with each decoded bit d_k by the first decoder DEC₁ is a relevant piece of information for the second decoder DEC₂

$$\Lambda_1(d_k) = \text{Log} \frac{P_r\{d_k = 1 / \text{observation}\}}{P_r\{d_k = 0 / \text{observation}\}} \quad (8)$$

where $P_r\{d_k = i / \text{observation}\}$, $i = 0, 1$ is the a posteriori probability (APP) of the data bit d_k .

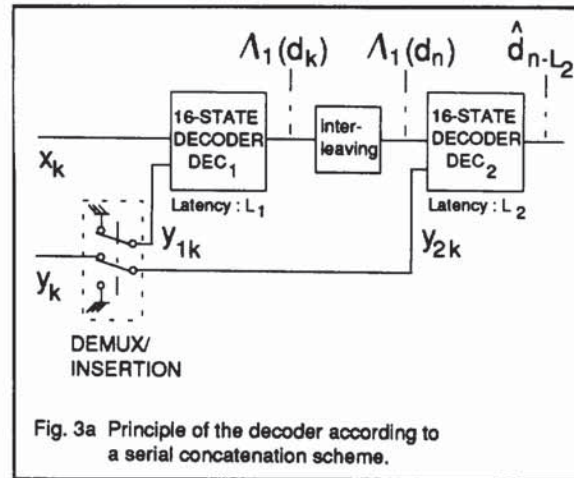

III - OPTIMAL DECODING OF RSC CODES WITH WEIGHTED DECISION

The VITERBI algorithm is an optimal decoding method which minimizes the probability of sequence error for convolutional codes. Unfortunately this algorithm is not able to yield the APP for each decoded bit. A relevant algorithm for this purpose has been proposed by BAHLL *et al.* [1]. This algorithm minimizes the bit error probability in decoding linear block and convolutional codes and yields the APP for each decoded bit. For RSC codes, the BAHLL *et al.* algorithm must be modified in order to take into account their recursive character.

III - 1 Modified BAHLL *et al.* algorithm for RSC codes

Consider a RSC code with constraint length K ; at time k the encoder state S_k is represented by a K -uple

$$S_k = (a_k, a_{k-1}, \dots, a_{k-K+1}) \quad (9)$$

Also suppose that the information bit sequence $\{d_k\}$ is made up of N independent bits d_k , taking values 0 and 1 with equal probability and that the encoder initial state S_0 and final state S_N are both equal to zero, *i.e.*

$$S_0 = S_N = (0, 0, \dots, 0) = 0 \quad (10)$$

The encoder output codeword sequence, noted $C_1^N = \{C_1, \dots, C_k, \dots, C_N\}$ is the input to a discrete gaussian memoryless channel whose output is the sequence $R_1^N = \{R_1, \dots, R_k, \dots, R_N\}$ where $R_k = (x_k, y_k)$ is defined by relations (7a) and (7b).

The APP of a decoded data bit d_k can be derived from the joint probability $\lambda_k^i(m)$ defined by

$$\lambda_k^i(m) = P_r \{d_k = i, S_k = m / R_1^N\} \quad (11)$$

and thus, the APP of a decoded data bit d_k is equal to

$$P_r \{d_k = i / R_1^N\} = \sum_m \lambda_k^i(m), \quad i = 0, 1. \quad (12)$$

From relations (8) and (12), the LLR $\Lambda(d_k)$ associated with a decoded bit d_k can be written as

$$\Lambda(d_k) = \text{Log} \frac{\sum_m \lambda_k^1(m)}{\sum_m \lambda_k^0(m)}. \quad (13)$$

Finally the decoder can make a decision by comparing $\Lambda(d_k)$ to a threshold equal to zero

$$\begin{aligned} \hat{d}_k &= 1 & \text{if } \Lambda(d_k) > 0 \\ \hat{d}_k &= 0 & \text{if } \Lambda(d_k) < 0. \end{aligned} \quad (14)$$

In order to compute the probability $\lambda_k^i(m)$, let us introduce the probability functions $\alpha_k^i(m)$, $\beta_k(m)$ and $\gamma_i(R_k, m', m)$

$$\alpha_k^i(m) = \frac{P_r \{d_k = i, S_k = m, R_1^k\}}{P_r \{R_1^k\}} P_r \{d_k = i, S_k = m / R_1^k\} \quad (15)$$

$$\beta_k(m) = \frac{P_r \{R_{k+1}^N / S_k = m\}}{P_r \{R_{k+1}^N / R_1^k\}} \quad (16)$$

$$\gamma_i(R_k, m', m) = P_r \{d_k = i, R_k, S_k = m / S_{k-1} = m'\}. \quad (17)$$

The joint probability $\lambda_k^i(m)$ can be rewritten using BAYES rule

$$\lambda_k^i(m) = \frac{P_r \{d_k = i, S_k = m, R_1^k, R_{k+1}^N\}}{P_r \{R_1^k, R_{k+1}^N\}}. \quad (18)$$

Thus we obtain

$$\lambda_k^i(m) = \frac{P_r \{d_k = i, S_k = m, R_1^k\}}{P_r \{R_1^k\}} \frac{P_r \{R_{k+1}^N / d_k = i, S_k = m, R_1^k\}}{P_r \{R_{k+1}^N / R_1^k\}}. \quad (19)$$

Taking into account that events after time k are not influenced by observation R_1^k and bit d_k if state S_k is known, the probability $\lambda_k^i(m)$ is equal

$$\lambda_k^i(m) = \alpha_k^i(m) \beta_k(m). \quad (20)$$

The probabilities $\alpha_k^i(m)$ and $\beta_k(m)$ can be recursively calculated from probability $\gamma_i(R_k, m', m)$. From annex I, we obtain

$$\alpha_k^i(m) = \frac{\sum_{m' j=0}^1 \gamma_i(R_k, m', m) \alpha_{k-1}^j(m')}{\sum_m \sum_{m' i=0}^1 \sum_{j=0}^1 \gamma_i(R_k, m', m) \alpha_{k-1}^j(m')} \quad (21)$$

and

$$\beta_k(m) = \frac{\sum_{m' i=0}^1 \gamma_i(R_{k+1}, m, m') \beta_{k+1}(m')}{\sum_m \sum_{m' i=0}^1 \sum_{j=0}^1 \gamma_i(R_{k+1}, m', m) \alpha_k^j(m')} \quad (22)$$

The probability $\gamma_i(R_k, m', m)$ can be determined from transition probabilities of the discrete gaussian memoryless

channel and transition probabilities of the encoder trellis. From relation (17), $\gamma_i(R_k, m', m)$ is given by

$$\begin{aligned} \gamma_i(R_k, m', m) &= p(R_k / d_k = i, S_k = m, S_{k-1} = m') \\ &= q(d_k = i / S_k = m, S_{k-1} = m') \pi(S_k = m / S_{k-1} = m') \end{aligned} \quad (23)$$

where $p(\cdot)$ is the transition probability of the discrete gaussian memoryless channel. Conditionally to $(d_k = i, S_k = m, S_{k-1} = m')$, x_k and y_k are two uncorrelated gaussian variables and thus we obtain

$$\begin{aligned} p(R_k / d_k = i, S_k = m, S_{k-1} = m') &= \\ p(x_k / d_k = i, S_k = m, S_{k-1} = m') &= \\ p(y_k / d_k = i, S_k = m, S_{k-1} = m'). \end{aligned} \quad (24)$$

Since the convolutional encoder is a deterministic machine, $q(d_k = i / S_k = m, S_{k-1} = m')$ is equal to 0 or 1. The transition state probabilities $\pi(S_k = m / S_{k-1} = m')$ of the trellis are defined by the encoder input statistic. Generally, $P_r \{d_k = 1\} = P_r \{d_k = 0\} = 1/2$ and since there are two possible transitions from each state, $\pi(S_k = m / S_{k-1} = m') = 1/2$ for each of these transitions.

Different steps of modified BAML *et al.* algorithm

-Step 0 : Probabilities $\alpha_0^i(m)$ and $\beta_N(m)$ are initialized according to relation (12)

$$\alpha_0^i(0) = 1 \quad \alpha_0^i(m) = 0 \quad \forall m \neq 0, \quad i = 0, 1 \quad (25a)$$

$$\beta_N(0) = 1 \quad \beta_N(m) = 0 \quad \forall m \neq 0. \quad (25b)$$

-Step 1 : For each observation R_k , the probabilities $\alpha_k^i(m)$ and $\gamma_i(R_k, m', m)$ are computed using relations (21) and (23) respectively.

-Step 2 : When the sequence R_1^N has been completely received, probabilities $\beta_k(m)$ are computed using relation (22), and probabilities $\alpha_k^i(m)$ and $\beta_k(m)$ are multiplied in order to obtain $\lambda_k^i(m)$. Finally the LLR associated with each decoded bit d_k is computed from relation (13).

IV- THE EXTRINSIC INFORMATION OF THE RSC DECODER

In this chapter, we will show that the LLR $\Lambda(d_k)$ associated with each decoded bit d_k , is the sum of the LLR of d_k at the decoder input and of another information called extrinsic information, generated by the decoder.

Using the LLR $\Lambda(d_k)$ definition (13) and relations (20) and (21), we obtain

$$\Lambda(d_k) = \text{Log} \frac{\sum_m \sum_{m' j=0}^1 \gamma_i(R_k, m', m) \alpha_{k-1}^j(m') \beta_k(m)}{\sum_m \sum_{m' j=0}^1 \gamma_0(R_k, m', m) \alpha_{k-1}^j(m') \beta_k(m)}. \quad (26)$$

Since the encoder is systematic ($X_k = d_k$), the transition probability $p(x_k / d_k = i, S_k = m, S_{k-1} = m')$ in expression $\gamma_i(R_k, m', m)$ is independent of state values S_k and S_{k-1} . Therefore we can factorize this transition probability in the numerator and in the denominator of relation (26)

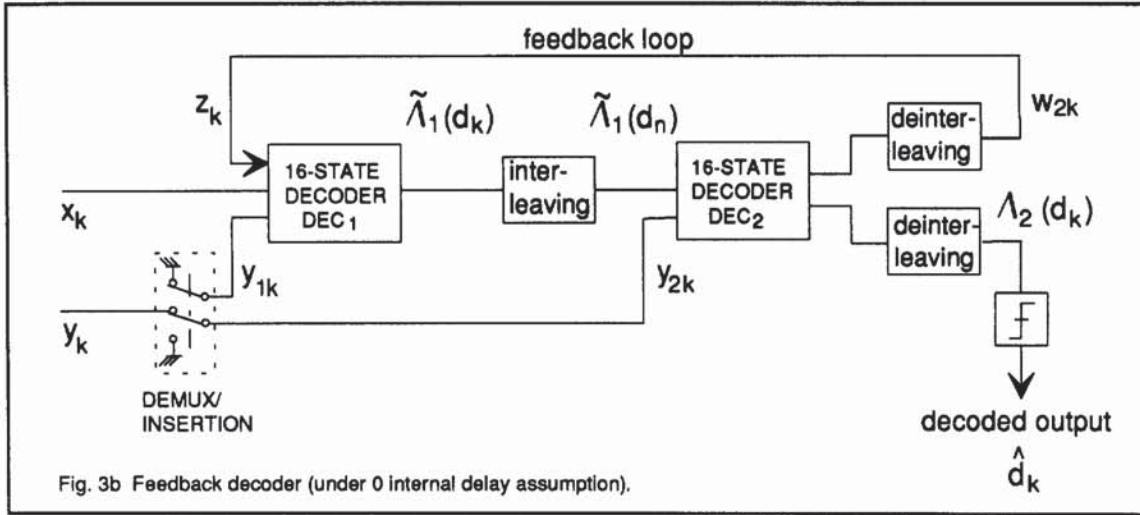

Fig. 3b Feedback decoder (under 0 internal delay assumption).

$$\Lambda(d_k) = \text{Log} \frac{p(x_k/d_k=1)}{p(x_k/d_k=0)} + \frac{\sum_{m,m',j=0}^1 \gamma_1(y_k, m', m) \alpha_{k-1}^j(m') \beta_k(m)}{\sum_{m,m',j=0}^1 \gamma_0(y_k, m', m) \alpha_{k-1}^j(m') \beta_k(m)} \quad (27)$$

Conditionally to $d_k=1$ (resp. $d_k=0$), variables x_k are gaussian with mean 1 (resp. -1) and variance σ^2 , thus the LLR $\Lambda(d_k)$ is still equal to

$$\Lambda(d_k) = \frac{2}{\sigma^2} x_k + W_k \quad (28)$$

where

$$W_k = \Lambda(d_k) \Big|_{x_k=0} = \frac{\sum_{m,m',j=0}^1 \gamma_1(y_k, m', m) \alpha_{k-1}^j(m') \beta_k(m)}{\sum_{m,m',j=0}^1 \gamma_0(y_k, m', m) \alpha_{k-1}^j(m') \beta_k(m)} \quad (29)$$

W_k is a function of the redundant information introduced by the encoder. In general W_k has the same sign as d_k ; therefore W_k may improve the LLR associated with each decoded data bit d_k . This quantity represents the extrinsic information supplied by the decoder and does not depend on decoder input x_k . This property will be used for decoding the two parallel concatenated encoders.

V - DECODING SCHEME OF PARALLEL CONCATENATION CODES

In the decoding scheme represented in Fig. 3a, decoder DEC₁ computes LLR $\Lambda_1(d_k)$ for each transmitted bit d_k from sequences $\{x_k\}$ and $\{y_k\}$, then the decoder DEC₂ performs the decoding of sequence $\{d_k\}$ from sequences $\{\Lambda_1(d_k)\}$ and $\{y_k\}$. Decoder DEC₁ uses the modified Bahl *et al.* algorithm and decoder DEC₂ may use the VITERBI algorithm. The global decoding rule is not optimal because the first decoder uses only a fraction of the available redundant information. Therefore it is possible to improve the performance of this serial decoder by using a feedback loop.

V-1 Decoding with a feedback loop

We consider now that both decoders DEC₁ and DEC₂ use the modified Bahl *et al.* algorithm. We have seen in section IV that the LLR at the decoder output can be expressed as a sum of two terms if the decoder inputs were independent. Hence if the decoder DEC₂ inputs $\Lambda_1(d_k)$ and y_{2k} are independent, the LLR $\Lambda_2(d_k)$ at the decoder DEC₂ output can be written as

$$\Lambda_2(d_k) = f(\Lambda_1(d_k)) + W_{2k} \quad (30)$$

with

$$\Lambda_1(d_k) = \frac{2}{\sigma^2} x_k + W_{1k} \quad (31)$$

From relation (29), we can see that the decoder DEC₂ extrinsic information W_{2k} is a function of the sequence $\{\Lambda_1(d_n)\}_{n \neq k}$. Since $\Lambda_1(d_n)$ depends on observation R_1^N , extrinsic information W_{2k} is correlated with observations x_k and y_{1k} . Nevertheless from relation (29), the greater $|n-k|$ is, the less correlated are $\Lambda_1(d_n)$ and observations x_k, y_k . Thus, due to the presence of interleaving between decoders DEC₁ and DEC₂, extrinsic information W_{2k} and observations x_k, y_{1k} are weakly correlated. Therefore extrinsic information W_{2k} and observations x_k, y_{1k} can be jointly used for carrying out a new decoding of bit d_k , the extrinsic information $z_k = W_{2k}$ acting as a diversity effect in an iterative process.

In Fig. 3b, we have depicted a new decoding scheme using the extrinsic information W_{2k} generated by decoder DEC₂ in a feedback loop. This decoder does not take into account the different delays introduced by decoder DEC₁ and DEC₂ and a more realistic decoding structure will be presented later.

The first decoder DEC₁ now has three data inputs, (x_k, y_{1k}, z_k) and probabilities $\alpha_{1k}^j(m)$ and $\beta_{1k}(m)$ are computed in substituting $R_k = \{x_k, y_{1k}\}$ by $R_k = \{x_k, y_{1k}, z_k\}$ in relations (21) and (22). Taking into account that z_k is weakly correlated with x_k and y_{1k} and supposing that z_k can be approximated by a gaussian variable with variance $\sigma_z^2 \neq \sigma^2$, the transition probability of the discrete gaussian memoryless channel can be now factored in three terms

$$p(R_k / d_k = i, S_k = m, S_{k-1} = m') = p(x_k / i) p(y_k / i) p(z_k / i) \quad (32)$$

The encoder C_1 with initial rate R_1 , through the feedback loop, is now equivalent to a rate R'_1 encoder with

$$R'_1 = \frac{R_1}{1 + R_1} \quad (33)$$

The first decoder obtains an additional redundant information with z_k that may significantly improve its performances; the term *Turbo-codes* is given for this iterative decoder scheme with reference to the turbo engine principle.

With the feedback decoder, the LLR $\Lambda_1(d_k)$ generated by decoder DEC_1 is now equal to

$$\Lambda_1(d_k) = \frac{2}{\sigma^2} x_k + \frac{2}{\sigma_z^2} z_k + W_{1k} \quad (34)$$

where W_{1k} depends on sequence $\{z_n\}_{n \neq k}$. As indicated above, information z_k has been built by decoder DEC_2 at the previous decoding step. Therefore z_k must not be used as input information for decoder DEC_2 . Thus decoder DEC_2 input sequences at step p ($p \geq 2$) will be sequences

$\{\tilde{\Lambda}_1(d_n)\}$ and $\{y_{2k}\}$ with

$$\tilde{\Lambda}_1(d_n) = \Lambda_1(d_n)_{z_n=0} \quad (35)$$

Finally from relation (30), decoder DEC_2 extrinsic information $z_k = W_{2k}$, after deinterleaving, can be written as

$$z_k = W_{2k} = \Lambda_2(d_k)_{\tilde{\Lambda}_1(d_k)=0} \quad (36)$$

and the decision at the decoder DEC output is

$$\hat{d}_k = \text{sign}[\Lambda_2(d_k)] \quad (37)$$

The decoding delays introduced by decoder DEC ($DEC=DEC_1+DEC_2$), the interleaver and the deinterleaver imply that the feedback information z_k must be used through an iterative process as represented in Fig. 4a, 4b. In fact, the global decoder circuit is composed of P pipelined identical elementary decoders (Fig. 4a). The p th decoder DEC (Fig. 4b) input, is made up of demodulator output sequences $(x)_p$ and $(y)_p$ through a delay line and of extrinsic information $(z)_p$ generated by the $(p-1)$ th decoder DEC . Note that the variance σ_z^2 of the extrinsic information and the variance of $\tilde{\Lambda}_1(d_k)$ must be estimated at each decoding step p .

V-2 Interleaving

The interleaver uses a square matrix and bits $\{d_k\}$ are written row by row and read pseudo-randomly. This non-uniform reading rule is able to spread the residual error blocks of rectangular form, that may set up in the interleaver located behind the first decoder DEC_1 , and to give the greater free distance as possible to the concatenated (parallel) code.

VI - RESULTS

For a rate $R=1/2$ encoder with constraint length $K=5$, generators $G_1=37$, $G_2=21$ and parallel concatenation ($R_1=R_2=2/3$), we have computed the Bit Error Rate (BER) after each decoding step using the Monte Carlo method, as a function of signal to noise ratio E_b/N_0 where E_b is the energy received per information bit d_k and N_0 is the noise monolateral power spectral density. The interleaver consists of a 256×256 matrix and the modified BAHL *et al.* algorithm has been used with length data block of $N=65536$ bits. In

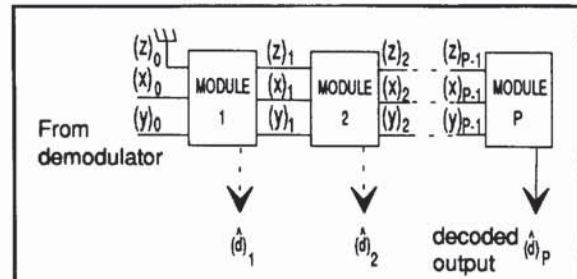

Fig. 4a Modular pipelined decoder, corresponding to an iterative process of the feedback decoding.

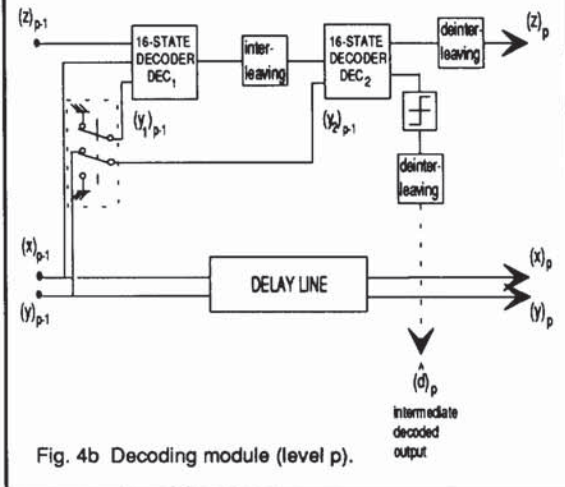

Fig. 4b Decoding module (level p).

order to evaluate a BER equal to 10^{-5} , we have considered 128 data blocks i.e. approximately 8×10^6 bits d_k . The BER versus E_b/N_0 , for different values of p is plotted in Fig. 5. For any given signal to noise ratio greater than 0 dB, the BER decreases as a function of the decoding step p . The coding gain is fairly high for the first values of p ($p=1,2,3$) and carries on increasing for the subsequent values of p . For $p=18$ for instance, the BER is lower than 10^{-5} at $E_b/N_0=0,7$ dB. Remember that the Shannon limit for a binary modulation with $R=1/2$, is $P_e = 0$ (several authors take $P_e=10^{-5}$ as a reference) for $E_b/N_0=0$ dB. With parallel concatenation of RSC convolutional codes and feedback decoding, the performances are at 0,7 dB from Shannon's limit.

The influence of the constraint length on the BER has also been examined. For K greater than 5, at $E_b/N_0=0,7$ dB, the BER is slightly worst at the first ($p=1$) decoding step and the feedback decoding is inefficient to improve the final BER. For K smaller than 5, at $E_b/N_0=0,7$ dB, the BER is slightly better at the first decoding step than for K equal to 5, but the correction capacity of encoders C_1 and C_2 is too weak to improve the BER with feedback decoding. For $K=4$ (i.e. 8-state elementary decoders) and after iteration 18, a BER of 10^{-5} is achieved at $E_b/N_0=0,9$ dB. For K equal to 5, we have tested several generators (G_1, G_2) and the best results were achieved with $G_1=37, G_2=21$.

Explore Litigation Insights

Docket Alarm provides insights to develop a more informed litigation strategy and the peace of mind of knowing you're on top of things.

Real-Time Litigation Alerts



Keep your litigation team up-to-date with **real-time alerts** and advanced team management tools built for the enterprise, all while greatly reducing PACER spend.

Our comprehensive service means we can handle Federal, State, and Administrative courts across the country.

Advanced Docket Research



With over 230 million records, Docket Alarm's cloud-native docket research platform finds what other services can't. Coverage includes Federal, State, plus PTAB, TTAB, ITC and NLRB decisions, all in one place.

Identify arguments that have been successful in the past with full text, pinpoint searching. Link to case law cited within any court document via Fastcase.

Analytics At Your Fingertips



Learn what happened the last time a particular judge, opposing counsel or company faced cases similar to yours.

Advanced out-of-the-box PTAB and TTAB analytics are always at your fingertips.

API

Docket Alarm offers a powerful API (application programming interface) to developers that want to integrate case filings into their apps.

LAW FIRMS

Build custom dashboards for your attorneys and clients with live data direct from the court.

Automate many repetitive legal tasks like conflict checks, document management, and marketing.

FINANCIAL INSTITUTIONS

Litigation and bankruptcy checks for companies and debtors.

E-DISCOVERY AND LEGAL VENDORS

Sync your system to PACER to automate legal marketing.