

UNITED STATES PATENT AND TRADEMARK OFFICE

---

BEFORE THE PATENT TRIAL AND APPEAL BOARD

---

VIPTELA, INC.,  
Petitioner,

v.

FATPIPE NETWORKS INDIA LIMITED,  
Patent Owner.

---

Case IPR2017-00684  
Patent 6,775,235 B2

---

Before STACEY G. WHITE, MICHELLE N. WORMMEESTER, and  
CHRISTA P. ZADO, *Administrative Patent Judges*.

ZADO, *Administrative Patent Judge*.

DECISION

Institution of *Inter Partes* Review  
35 U.S.C. § 314(a) and 37 C.F.R. § 42.108

## I. INTRODUCTION

### A. Background

Viptela, Inc. (“Petitioner”) filed a Petition (Paper 1, “Pet.”) seeking to institute an *inter partes* review of claims 4–15, 19, and 22–24 of U.S. Patent No. 6,775,235 B2 (Ex. 1001, “the ’235 patent”) pursuant to 35 U.S.C. §§ 311–319. FatPipe Networks India Limited (“Patent Owner”) filed a Preliminary Response.<sup>1</sup> (Paper 6, “Prelim. Resp.”). We have jurisdiction under 35 U.S.C. § 314(a), which provides that an *inter partes* review may not be instituted “unless . . . there is a reasonable likelihood that the petitioner would prevail with respect to at least 1 of the claims challenged in the petition.”

Petitioner contends the challenged claims are unpatentable under 35 U.S.C. §§ 102 and 103 on the following specific grounds (Pet. 4, 9–60):

Reference(s)	Basis	Claims Challenged
Karol <sup>2</sup>	§ 102	4–11, 14, 19 and 22–24
Karol and Stallings <sup>3</sup>	§ 103	5, 6, 11–15, 19, and 22–24
Karol	§ 103	4–15, 19, and 22–24

---

<sup>1</sup> The panel takes notice that the caption in Patent Owner’s Preliminary Response (Paper 6) reads “FATPIPE NETWORKS PRIVATE LIMITED,” which is a change from what Patent Owner stated as the Real Party-In-Interest in its Mandatory Notices (Paper 5, 1). The panel reminds Patent Owner that pursuant to 37 C.F.R. § 42.8(a)(3), new mandatory notices must be filed within 21 days if there are any changes to the information required under 37 C.F.R. § 42.8(b).

<sup>2</sup> U.S. Patent No. 6,628,617 B1 (“Karol,” Ex. 1006).

<sup>3</sup> William Stallings, *Data and Computer Communications*, Prentice-Hall, 5th Ed., 1997, ISBN-81-203-1240-6 (“Stallings,” Ex. 1011).

Our factual findings and conclusions at this stage of the proceeding are based on the evidentiary record developed thus far. This is not a final decision as to patentability of claims for which *inter partes* review is instituted. Our final decision will be based on the record as fully developed during trial. For reasons discussed below, we institute *inter partes* review of claims 6 and 22–24 of the '235 patent.

*B. Related Proceedings*

Petitioner informs us that the '235 patent has been asserted in the following proceeding: *FatPipe, Inc. v. Viptela, Inc.*, No. 1:16-cv-182 (D. Del.). Pet. 1; *see also* Paper 5, 1. In addition, the '235 patent is the subject of a separate proceeding, IPR2016-00976, filed by Talari Networks, Inc. Pet. 2; Paper 5, 2.

*C. The '235 Patent*

The '235 patent describes a system and method for communicating using two or more disparate networks in parallel. Ex. 1001, Abstract. For example, an embodiment of this system could be composed of a virtual private network (“VPN”) in parallel with a frame relay network. *Id.* at 1:19–24. These parallel networks back each other up in case of failure and when both networks are operational their loads are balanced between the parallel networks. *Id.* at Abstract. An embodiment of this system is depicted in Figure 10, which is shown below.

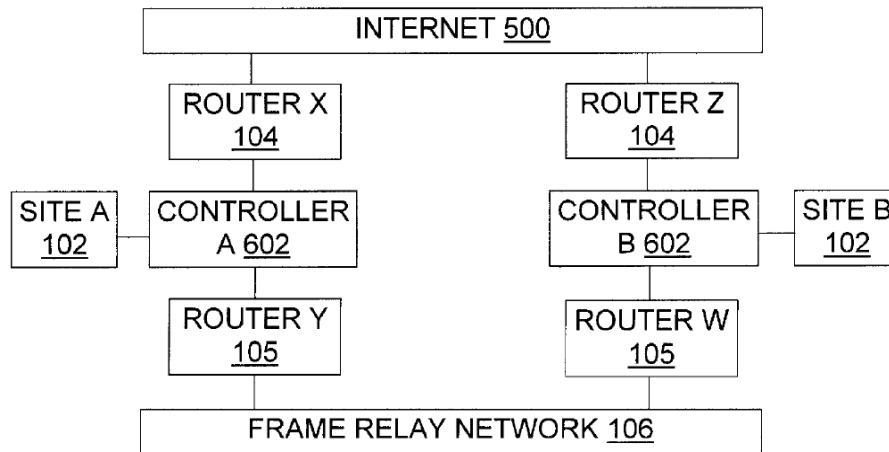

Fig. 10

Figure 10 depicts an example of the network topology described in the '235 patent. *Id.* at 8:29–30. Two sites 102 transmit and/or receive data from one another. *Id.* at 2:38–40. These sites are connected by two disparate networks, Internet 500 and frame relay network 106. *Id.* at 8:30–32. Each location has frame relay router 105 and Internet router 104. *Id.* at 8:32–33. “Access to the disparate networks at site A and site B is through an inventive controller 602 at each site.” *Id.* at 6:34–36. Controller 602 “allows load-balancing, redundancy, or other criteria to be used dynamically, on a granularity as fine as packet-by-packet, to direct packets to an Internet router and/or frame relay/point-to-point router according to the criteria.” *Id.* at 9:12–17.

Figure 7 of the '235 patent is reproduced below.

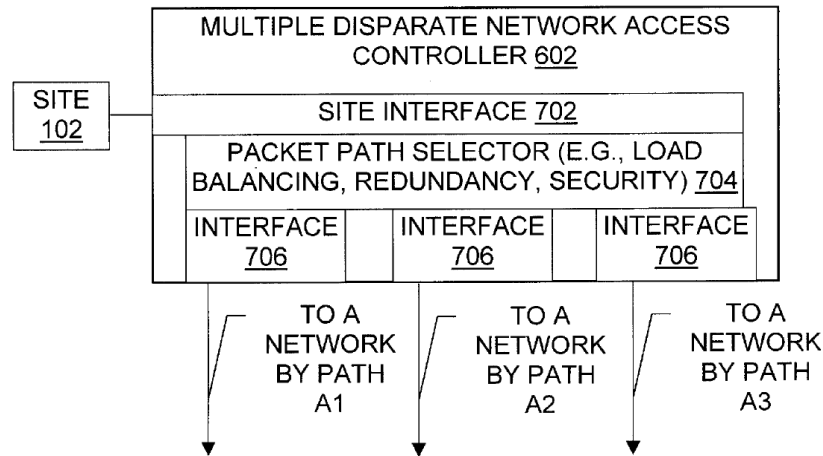

Fig. 7

Figure 7 depicts controller 602. *Id.* at 10:59–60. Controller 602 is connected to site 102 via site interface 702. *Id.* at 10:60–63. Packet path selector 704 is hardware or software that determines which path a given packet is to travel. *Id.* at 11:2–6. The criteria used to determine which path a packet travels may be based on concerns such as redundancy, load-balancing, or security. *Id.* at 11:6–63. Controller 602 also has two or more network interfaces 706 (at least one per each network for which controller 602 controls access). *Id.* at 11:64–67.

#### D. Illustrative Claim

As noted above, Petitioner challenges claims 4–15, 19, and 22–24 of the '235 patent, of which claims 4, 5, 19, and 22 are independent. Claim 22 is illustrative of the challenged claims and is reproduced below:

22. A computer storage medium having a configuration that represents data and instructions which will cause performance of a method for combining connections for access to multiple parallel disparate networks, the method comprising the steps of:

# Explore Litigation Insights

Docket Alarm provides insights to develop a more informed litigation strategy and the peace of mind of knowing you're on top of things.

## Real-Time Litigation Alerts



Keep your litigation team up-to-date with **real-time alerts** and advanced team management tools built for the enterprise, all while greatly reducing PACER spend.

Our comprehensive service means we can handle Federal, State, and Administrative courts across the country.

## Advanced Docket Research



With over 230 million records, Docket Alarm's cloud-native docket research platform finds what other services can't. Coverage includes Federal, State, plus PTAB, TTAB, ITC and NLRB decisions, all in one place.

Identify arguments that have been successful in the past with full text, pinpoint searching. Link to case law cited within any court document via Fastcase.

## Analytics At Your Fingertips



Learn what happened the last time a particular judge, opposing counsel or company faced cases similar to yours.

Advanced out-of-the-box PTAB and TTAB analytics are always at your fingertips.

## API

Docket Alarm offers a powerful API (application programming interface) to developers that want to integrate case filings into their apps.

## LAW FIRMS

Build custom dashboards for your attorneys and clients with live data direct from the court.

Automate many repetitive legal tasks like conflict checks, document management, and marketing.

## FINANCIAL INSTITUTIONS

Litigation and bankruptcy checks for companies and debtors.

## E-DISCOVERY AND LEGAL VENDORS

Sync your system to PACER to automate legal marketing.