

UNITED STATES PATENT AND TRADEMARK OFFICE

BEFORE THE PATENT TRIAL AND APPEAL BOARD

LG Electronics, Inc.
Petitioner,

v.

FastVDO LLC
Patent Owner.

Patent No. 5,850,482

Inter Parte Review No. _____

U.S. Patent No. 5,850,482 to Meany et al.

Exhibit 1001

- [54] **ERROR RESILIENT METHOD AND APPARATUS FOR ENTROPY CODING**
- [75] Inventors: **James J. Meany**, Des Peres;
Christopher J. Martens, Creve Coeur,
both of Mo.
- [73] Assignee: **McDonnell Douglas Corporation**, St.
Louis, Mo.
- [21] Appl. No.: **633,896**
- [22] Filed: **Apr. 17, 1996**
- [51] **Int. Cl.⁶** **G06K 9/00**
- [52] **U.S. Cl.** **382/232; 382/275**
- [58] **Field of Search** 382/232, 233,
382/234, 235, 236, 237, 238, 239, 240,
244, 245, 246, 248, 249, 250, 251, 252,
253, 270, 274, 275, 254, 305, 309, 310,
311, 224, 190, 166, 172, 306; 375/286,
298, 254, 264; 371/37.7, 43.1, 37.08, 37.5;
380/20, 10; 370/314; 348/476, 5.5; 340/825.44

[56] **References Cited**

U.S. PATENT DOCUMENTS

4,817,182	3/1989	Adelson et al.	382/56
5,014,134	5/1991	Lawton et al.	358/261.3
5,101,446	3/1992	Resnikoff et al.	382/56
5,168,493	12/1992	Nelson et al.	370/84
5,289,501	2/1994	Seshadri et al.	375/17
5,315,670	5/1994	Shapiro	382/56
5,321,750	6/1994	Nadan	380/20
5,321,776	6/1994	Shapiro	382/56
5,471,486	11/1995	Baggen et al.	371/37.1

OTHER PUBLICATIONS

Edward R. Fiala and Daniel H. Greene, Data Compression with Finite Windows, *Communications of the ACM*, vol. 32, No. 4, Apr. 1989, pp. 490-505.
 Timothy C. Bell, John G. Cleary and Ian H. Written, *Text Compression*, Prentice Hall, Copyright 1990, pp. 290-295.
 Imran Ali Shah, Olu Akiwumi-Assani and Brian Johnson, A Chip Set for Lossless Image Compression, *IEEE Journal of Solid-State Circuits*, vol. 26, No. 3, Mar. 1991, pp. 237-244.

Gregory K. Wallace, The JPEG Still Picture Compression Standard, *Communication of the ACM*, vol. 34, No. 4, Apr. 1991, pp. 30-45.

Olivier Rioul and Martin Vetterli, Wavelets and Signal Processing, *IEEE SP Magazine*, Oct. 1991, pp. 14-38.

Albert Cohen, Biorthogonal Wavelets, *Wavelets—A Tutorial in Theory and Applications*, Copyright 1992, pp. 123-152.

A. S. Lewis and G. Knowles, Image Compression Using the 2-D Wavelet, *IEEE Transaction on Image Processing*, vol. 1, No. 2, Apr. 1992, pp. 244-250.

(List continued on next page.)

Primary Examiner—Leo H. Boundreau
Assistant Examiner—Bijan Tadayon
Attorney, Agent, or Firm—Bell Seltzer Intellectual Property Group of Alston & Bird, LLP

[57] **ABSTRACT**

The error resilient method and apparatus for encoding data includes an encoder including a code word generator for generating a plurality of code words representative of respective portions of the data. The code word generator encodes data pursuant to split field coding in which each code word includes a prefix field and an associated suffix field. The prefix field includes information representative of a predetermined characteristic of the associated suffix field, such as the predetermined number of characters which form the associated suffix field. In addition, the suffix fields include information representative of at least some of the original data. Consequently, if the prefix field of a code word is decoded correctly, i.e., without the occurrence of bit error, the error resilient method and apparatus can correctly determine the length of the associated suffix field and the range of coefficient values to be represented by the associated suffix field such that the associated suffix field is resilient to errors. In order to increase the probability that the prefix field will be correctly decoded, the method and apparatus protects the prefix and suffix fields of the encoded data to greater and lesser degrees, respectively, such that the data can be more efficiently compressed.

30 Claims, 6 Drawing Sheets

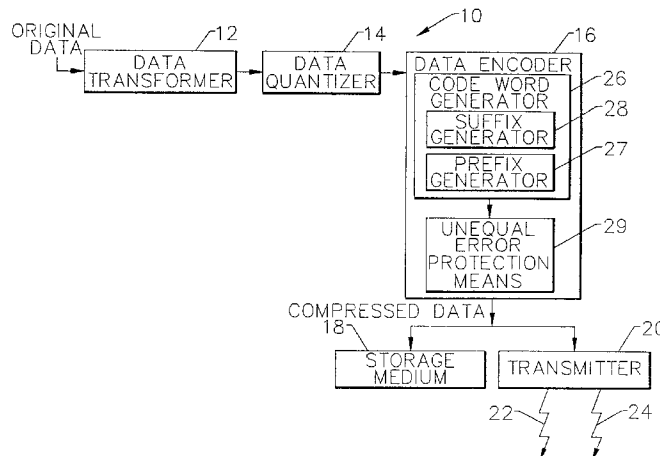

OTHER PUBLICATIONS

Mladen Victor Wickerhauser, *High-Resolution Still Picture Compression*, Apr. 19, 1992, pp. 1–33. (No Title of Publication).

Marc Antonini, Michel Barlaud, Pierre Mathieu and Ingrid Daubechies, Image Coding Using Wavelet Transform, *IEEE Transactions on Image Processing*, vol. 1, No. 2, Apr. 1992, pp. 205–220.

Naoto Tanabe and Nariman Farvardin, Subband Image Coding Using Entropy-Coded Quantization over Noisy Channels, *IEEE Journal on Selected Areas in Communications*, vol. 10, No. 5, Jun. 1992, pp. 926–943.

Amir Said and William A. Pearlman, Reversible image compression via multiresolution representation and predictive coding, *SPIE*, vol. 2094, 1993, pp. 664–674.

Jerome M. Shapiro, Embedded Image Coding Using Zerotrees of Wavelet Coefficients, *IEEE Transactions on Signal Processing*, vol. 41, No. 12, Dec. 1993, pp. 3445–3462.

Michael L. Hilton, Björn D. Jawerth and Ayan Sengupta, Compressing Still and Moving Images with Wavelets, *Multimedia Systems*, vol. 2, No. 3, Apr. 18, 1994, pp. 1–20.

Keith A. Birney and Thomas R. Fischer, On the Modeling of DCT and Subband Image Data for Compression, *IEEE Transactions on Image Processing*, vol. 4, No. 2, Feb. 1995, pp. 186–193.

Parthasarathy Sriram and Michael W. Marcellin, Image Coding Using Wavelet Transforms and Entropy-Constrained Trellis-Coded Quantization, *IEEE Transactions on Image Processing*, vol. 4, No. 6, Jun. 1995, pp. 725–733.

Björn Jawerth and Wim Sweldens, *An Overview Of Wavelet Based Multiresolution Analyses*, pp. 1–39. (No Title Of Publication), (No Date Of Publication).

Wim Sweldens, *The Lifting Scheme: A New Philosophy in Biorthogonal Wavelet Constructions*. (No Place Or Date Of Publication & No Page #).

Ahmad Zandi, James D. Allen, Edward L. Schwartz and Martin Boliek, *CREW: Compression with Reversible Embedded Wavelets*. (No Place Or Date) & (No Page #).

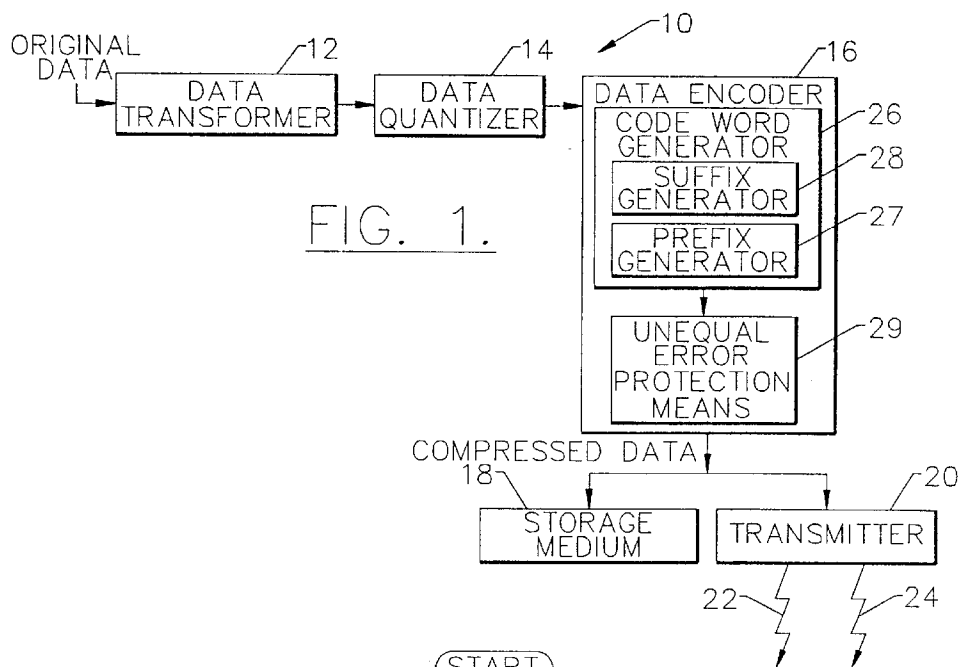

FIG. 1.

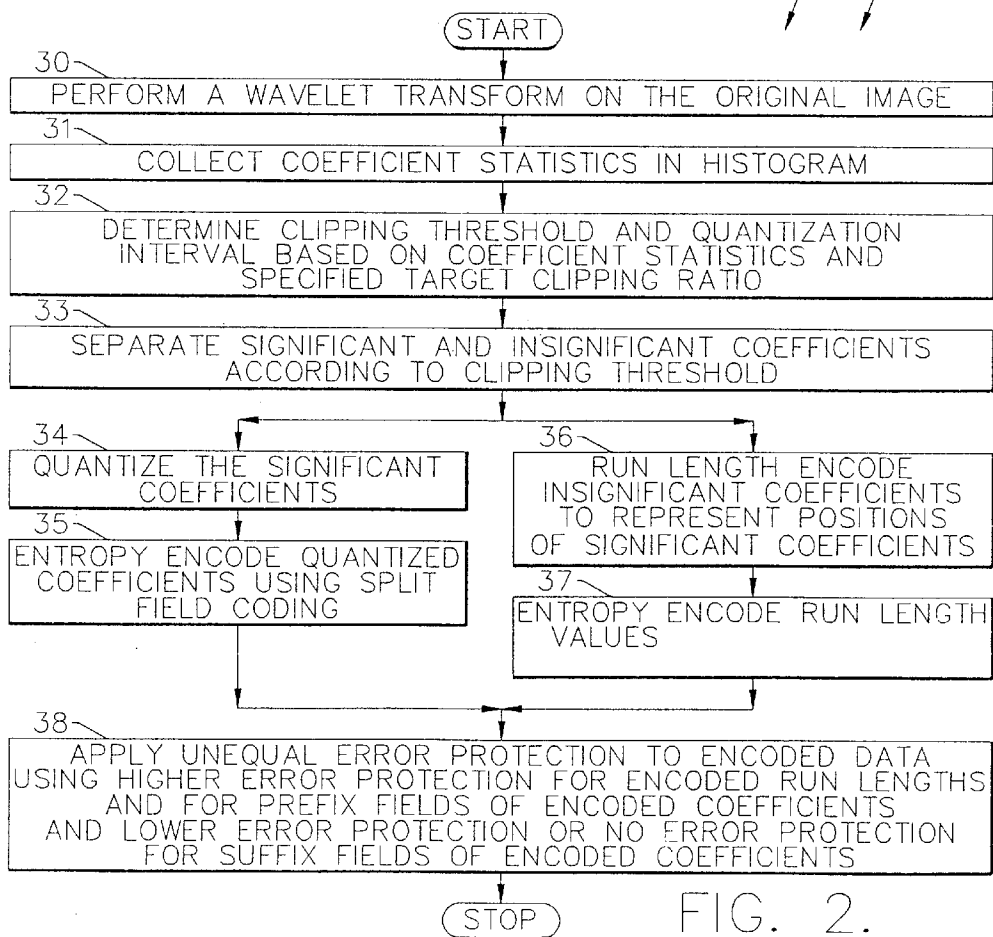

FIG. 2.

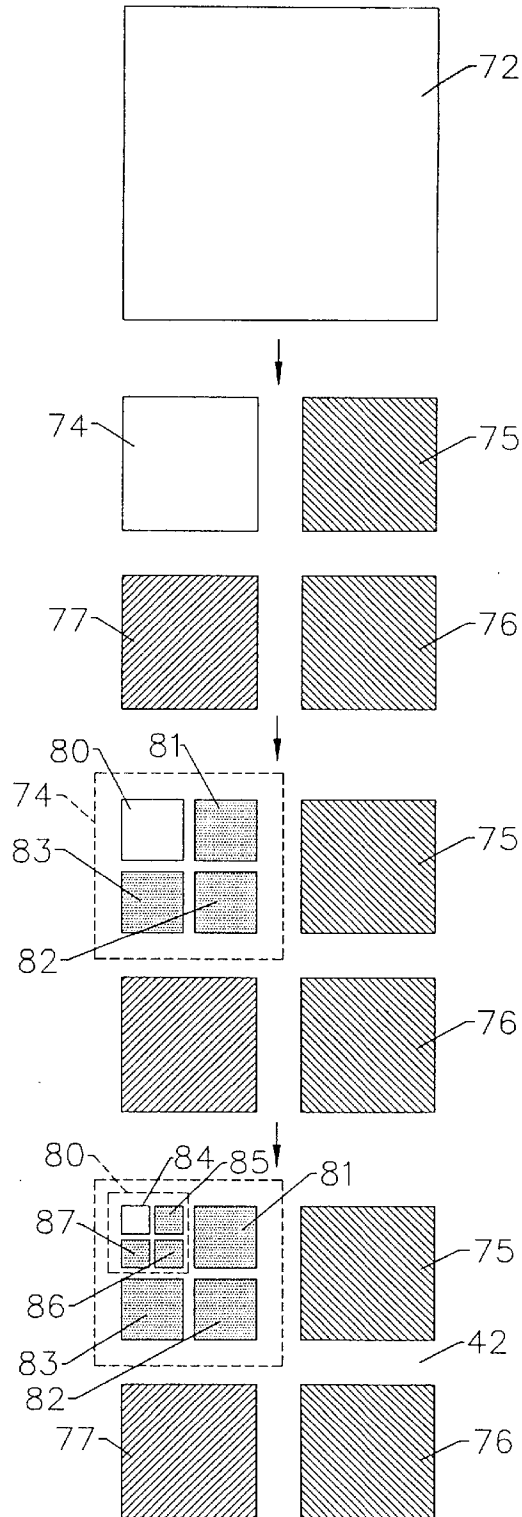

FIG. 3.

Explore Litigation Insights

Docket Alarm provides insights to develop a more informed litigation strategy and the peace of mind of knowing you're on top of things.

Real-Time Litigation Alerts



Keep your litigation team up-to-date with **real-time alerts** and advanced team management tools built for the enterprise, all while greatly reducing PACER spend.

Our comprehensive service means we can handle Federal, State, and Administrative courts across the country.

Advanced Docket Research



With over 230 million records, Docket Alarm's cloud-native docket research platform finds what other services can't. Coverage includes Federal, State, plus PTAB, TTAB, ITC and NLRB decisions, all in one place.

Identify arguments that have been successful in the past with full text, pinpoint searching. Link to case law cited within any court document via Fastcase.

Analytics At Your Fingertips



Learn what happened the last time a particular judge, opposing counsel or company faced cases similar to yours.

Advanced out-of-the-box PTAB and TTAB analytics are always at your fingertips.

API

Docket Alarm offers a powerful API (application programming interface) to developers that want to integrate case filings into their apps.

LAW FIRMS

Build custom dashboards for your attorneys and clients with live data direct from the court.

Automate many repetitive legal tasks like conflict checks, document management, and marketing.

FINANCIAL INSTITUTIONS

Litigation and bankruptcy checks for companies and debtors.

E-DISCOVERY AND LEGAL VENDORS

Sync your system to PACER to automate legal marketing.