



US006363345B1

(12) **United States Patent**
Marash et al.

(10) **Patent No.: US 6,363,345 B1**
(45) **Date of Patent: Mar. 26, 2002**

(54) **SYSTEM, METHOD AND APPARATUS FOR CANCELLING NOISE**

- (75) Inventors: **Joseph Marash**, Haifa; **Baruch Berdugo**, Kiriat-Ata, both of (IL)
- (73) Assignee: **Andrea Electronics Corporation**, Melville, NY (US)
- (*) Notice: Subject to any disclaimer, the term of this patent is extended or adjusted under 35 U.S.C. 154(b) by 0 days.

(21) Appl. No.: **09/252,874**

(22) Filed: **Feb. 18, 1999**

(51) **Int. Cl.**⁷ **G10L 21/02**

(52) **U.S. Cl.** **704/226; 704/233; 704/205**

(58) **Field of Search** 704/270, 500, 704/233, 200, 201, 205, 226, 227, 228, 211, 216; 379/22.08, 392.01, 3, 406.01, 406.12, 406.13, 406.14, 406.05

(56) **References Cited**

U.S. PATENT DOCUMENTS

2,379,514	A	7/1945	Fisher
2,972,018	A	2/1961	Hawley et al.
3,098,121	A	7/1963	Wadsworth
3,101,744	A	8/1963	Warnaka

(List continued on next page.)

FOREIGN PATENT DOCUMENTS

DE	2640324	3/1978
DE	3719963	3/1988
DE	4008595	9/1991
EP	0 059 745 B1	9/1982
EP	0 380 290 A2	8/1990
EP	0 390 386	10/1990
EP	0 411 360 B1	2/1991
EP	0 509 742 A2	10/1992
EP	0 483 845	1/1993

(List continued on next page.)

OTHER PUBLICATIONS

- B.D. Van Veen and K.M. Buckley, "Beamforming: A Versatile Approach to Spatial Filtering," IEEE ASSN Magazine, vol. 5, No. 2, Apr. 1988, pp. 4-24.
- Beranek, *Acoustics* (American Institute of Physics, 1986) pp. 116-135.
- Boll, IEEE Trans. on Acous., vol. ASSP-27, No. 2, Apr. 1979, pp. 113-120.
- Daniel Sweeney, "Sound Conditioning Through DSP", The Equipment Authority, 1994.

(List continued on next page.)

Primary Examiner—Richemond Dorvil

(74) *Attorney, Agent, or Firm*—Frommer Lawrence & Haug; Thomas J. Kowalski

(57) **ABSTRACT**

A threshold detector precisely detects the positions of the noise elements, even within continuous speech segments, by determining whether frequency spectrum elements, or bins, of the input signal are within a threshold set according to current and future minimum values of the frequency spectrum elements. In addition, the threshold is continuously set and initiated within a predetermined period of time. The estimate magnitude of the input audio signal is obtained using a multiplying combination of the real and imaginary part of the input in accordance with the higher and lower values between the real and imaginary part of the signal. In order to further reduce instability of the spectral estimation, a two-dimensional smoothing is applied to the signal estimate using neighboring frequency bins and an exponential average over time. A filter multiplication effects the subtraction thereby avoiding phase calculation difficulties and effecting full-wave rectification which further reduces artifacts. Since the noise elements are determined within continuous speech segments, the noise is canceled from the audio signal nearly continuously thereby providing excellent noise cancellation characteristics. Residual noise reduction reduces the residual noise remaining after noise cancellation. Implementation may be effected in various noise canceling schemes including adaptive beamforming and noise cancellation using computer program applications installed as software or hardware.

47 Claims, 10 Drawing Sheets

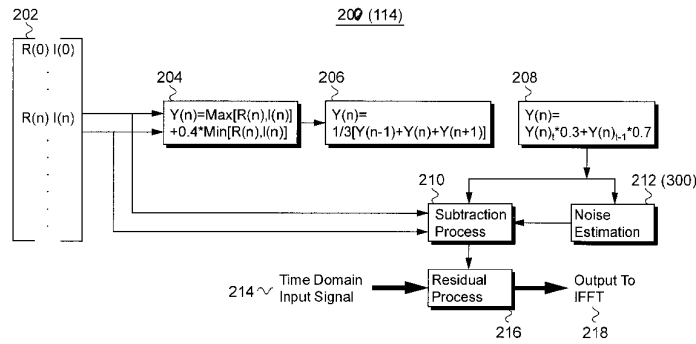

Noise Processing

U.S. PATENT DOCUMENTS

3,170,046	A	2/1965	Leale	4,752,961	A	6/1988	Kahn
3,247,925	A	4/1966	Warnaka	4,769,847	A	9/1988	Taguchi
3,262,521	A	7/1966	Warnaka	4,771,472	A	9/1988	Williams, III et al.
3,298,457	A	1/1967	Warnaka	4,783,798	A	11/1988	Leibholz et al.
3,330,376	A	7/1967	Warnaka	4,783,817	A	11/1988	Hamada et al.
3,394,226	A	7/1968	Andrews, Jr.	4,783,818	A	11/1988	Graupe et al.
3,416,782	A	12/1968	Warnaka	4,791,672	A	12/1988	Nunley et al.
3,422,921	A	1/1969	Warnaka	4,802,227	A	1/1989	Elko et al.
3,562,089	A	2/1971	Warnaka et al.	4,811,404	A	3/1989	Vilmur et al.
3,702,644	A	11/1972	Fowler et al.	4,833,719	A	5/1989	Carne et al.
3,830,988	A	8/1974	Mol et al.	4,837,832	A	6/1989	Fanshel
3,889,059	A	6/1975	Thompson et al.	4,847,897	A	7/1989	Means
3,890,474	A	6/1975	Glicksberg	4,862,506	A	8/1989	Landgarten et al.
4,068,092	A	1/1978	Ikoma et al.	4,878,188	A	10/1989	Ziegler et al.
4,122,303	A	10/1978	Chaplin et al.	4,908,855	A	3/1990	Ohga et al.
4,153,815	A	5/1979	Chaplin et al.	4,910,718	A	3/1990	Horn
4,169,257	A	9/1979	Smith	4,910,719	A	3/1990	Thubert
4,239,936	A	12/1980	Sakoe	4,928,307	A	5/1990	Lynn
4,241,805	A	12/1980	Chance, Jr.	4,930,156	A	5/1990	Norris
4,243,117	A	1/1981	Warnaka	4,932,063	A	6/1990	Nakamura
4,261,708	A	4/1981	Gallagher	4,937,871	A	6/1990	Hattori
4,321,970	A	3/1982	Thigpen	4,947,356	A	8/1990	Elliott et al.
4,334,740	A	6/1982	Wray	4,951,954	A	8/1990	MacNeill
4,339,018	A	7/1982	Warnaka	4,955,055	A	9/1990	Fujisaki et al.
4,363,007	A	12/1982	Haramoto et al.	4,956,867	A	9/1990	Zarek et al.
4,409,435	A	10/1983	Ono	4,959,865	A	9/1990	Stettiner et al.
4,417,098	A	11/1983	Chaplin et al.	4,963,071	A	10/1990	Larwin et al.
4,433,435	A	2/1984	David	4,965,834	A	10/1990	Miller
4,442,546	A	4/1984	Ishigaki	4,977,600	A	12/1990	Ziegler
4,453,600	A	6/1984	Thigpen	4,985,925	A	1/1991	Langberg et al.
4,455,675	A	6/1984	Bose et al.	4,991,433	A	2/1991	Warnaka et al.
4,459,851	A	7/1984	Crostack	5,001,763	A	3/1991	Moseley
4,461,025	A	7/1984	Franklin	5,010,576	A	4/1991	Hill
4,463,222	A	7/1984	Poradowski	5,018,202	A	5/1991	Takahashi et al.
4,473,906	A	9/1984	Warnaka et al.	5,023,002	A	6/1991	Schweizer et al.
4,477,505	A	10/1984	Warnaka	5,029,218	A	7/1991	Nagayasu
4,489,441	A	12/1984	Chaplin et al.	5,046,103	A	9/1991	Warnaka et al.
4,490,841	A	12/1984	Chaplin et al.	5,052,510	A	10/1991	Gossman
4,494,074	A	1/1985	Bose	5,070,527	A	12/1991	Lynn
4,495,643	A	1/1985	Orban	5,075,694	A	12/1991	Donnangelo et al.
4,517,415	A	5/1985	Laurence	5,086,385	A	2/1992	Launey et al.
4,527,282	A	7/1985	Chaplin et al.	5,086,415	A	2/1992	Takahashi et al.
4,530,304	A	7/1985	Gardos	5,091,954	A	2/1992	Sasaki et al.
4,539,708	A	9/1985	Norris	5,097,923	A	3/1992	Ziegler et al.
4,559,642	A	12/1985	Miyaji et al.	5,105,377	A	4/1992	Ziegler, Jr.
4,562,589	A	12/1985	Warnaka et al.	5,117,461	A	5/1992	Moseley
4,566,118	A	1/1986	Chaplin et al.	5,121,426	A	6/1992	Bavmhauer
4,570,155	A	2/1986	Skarman et al.	5,125,032	A	6/1992	Meister et al.
4,581,758	A	4/1986	Coker et al.	5,126,681	A	6/1992	Ziegler, Jr. et al.
4,589,136	A	5/1986	Poldy et al.	5,133,017	A	7/1992	Cain et al.
4,589,137	A	5/1986	Miller	5,134,659	A	7/1992	Moseley
4,600,863	A	7/1986	Chaplin et al.	5,138,663	A	8/1992	Moseley
4,622,692	A	11/1986	Cole	5,138,664	A	8/1992	Kimura et al.
4,628,529	A	12/1986	Borth et al.	5,142,585	A	8/1992	Taylor
4,630,302	A	12/1986	Kryter	5,192,918	A	3/1993	Sugiyama
4,630,304	A	12/1986	Borth et al.	5,208,864	A	5/1993	Kaneda
4,636,586	A	1/1987	Schiff	5,209,326	A	5/1993	Harper
4,649,505	A	3/1987	Zinser, Jr. et al.	5,212,764	A	5/1993	Ariyoshi
4,653,102	A	3/1987	Hansen	5,219,037	A	6/1993	Smith et al.
4,653,606	A	3/1987	Flanagan	5,226,077	A	7/1993	Lynn et al.
4,654,871	A	3/1987	Chaplin et al.	5,226,087	A	7/1993	Ono
4,658,426	A	4/1987	Chabries et al.	5,241,692	A	8/1993	Harrison et al.
4,672,674	A	6/1987	Clough et al.	5,251,263	A	10/1993	Andrea et al.
4,683,010	A	7/1987	Hartmann	5,251,863	A	10/1993	Gossman et al.
4,696,043	A	9/1987	Iwahara et al.	5,260,997	A	11/1993	Gathey et al.
4,718,096	A	1/1988	Meisel	5,272,286	A	12/1993	Cain et al.
4,731,850	A	3/1988	Levitt et al.	5,276,740	A	1/1994	Inanaga et al.
4,736,432	A	4/1988	Cantrell	5,311,446	A	5/1994	Ross et al.
4,741,038	A	4/1988	Elko et al.	5,311,453	A	5/1994	Denenberg et al.
4,750,207	A	6/1988	Gebert et al.	5,313,555	A	5/1994	Kamiya
				5,313,945	A	5/1994	Friedlander

5,315,661 A	5/1994	Gossman et al.	5,644,641 A	7/1997	Ikeda	
5,319,736 A	6/1994	Hunt	5,649,018 A	7/1997	Gifford et al.	
5,327,506 A	7/1994	Stites, III	5,652,770 A	7/1997	Eatwell	
5,332,203 A	7/1994	Gossman et al.	5,652,799 A	7/1997	Ross et al.	
5,335,011 A	8/1994	Addeo et al.	5,657,393 A	8/1997	Crow	
5,348,124 A	9/1994	Harper	5,664,021 A	9/1997	Chu et al.	
5,353,347 A	10/1994	Irissou et al.	5,668,747 A	9/1997	Obashi	
5,353,376 A	10/1994	Oh et al.	5,668,927 A	* 9/1997	Chan et al.	704/240
5,361,303 A	11/1994	Eatwell	5,673,325 A	9/1997	Andrea et al.	
5,365,594 A	11/1994	Ross et al.	5,676,353 A	10/1997	Jones et al.	
5,375,174 A	12/1994	Denenberg	5,689,572 A	11/1997	Ohki et al.	
5,381,473 A	1/1995	Andrea et al.	5,692,053 A	11/1997	Fuller et al.	
5,381,481 A	1/1995	Gammie et al.	5,692,054 A	11/1997	Parrella et al.	
5,384,843 A	1/1995	Masuda et al.	5,699,436 A	12/1997	Claybaugh et al.	
5,402,497 A	3/1995	Nishimoto et al.	5,701,344 A	12/1997	Wakui	
5,412,735 A	5/1995	Engebretson et al.	5,706,394 A	* 1/1998	Wynn	704/219
5,414,769 A	5/1995	Gathey et al.	5,715,319 A	2/1998	Chu	
5,414,775 A	5/1995	Scribner et al.	5,715,321 A	2/1998	Andrea et al.	
5,416,845 A	5/1995	Shen	5,719,945 A	2/1998	Fuller et al.	
5,416,847 A	5/1995	Boze	5,724,270 A	3/1998	Posch	
5,416,887 A	5/1995	Shimada	5,727,073 A	3/1998	Ikeda	
5,418,857 A	5/1995	Eatwell	5,732,143 A	3/1998	Andrea et al.	
5,423,523 A	6/1995	Gossman et al.	5,745,581 A	4/1998	Eatwell et al.	
5,431,008 A	7/1995	Ross et al.	5,748,749 A	5/1998	Miller et al.	
5,432,859 A	7/1995	Yang et al.	5,768,473 A	6/1998	Eatwell et al.	
5,434,925 A	7/1995	Nadim	5,774,859 A	6/1998	Houser et al.	
5,440,642 A	8/1995	Denenberg et al.	5,787,259 A	* 7/1998	Haroun et al.	709/253
5,448,637 A	9/1995	Yamaguchi et al.	5,798,983 A	8/1998	Kuhn et al.	
5,452,361 A	9/1995	Jones	5,812,682 A	9/1998	Ross et al.	
5,457,749 A	10/1995	Cain et al.	5,815,582 A	9/1998	Claybaugh et al.	
5,469,087 A	11/1995	Eatwell	5,818,948 A	* 10/1998	Gulick	381/77
5,471,106 A	11/1995	Curtis et al.	5,825,897 A	10/1998	Andrea et al.	
5,471,538 A	11/1995	Sasaki et al.	5,825,898 A	10/1998	Marash	
5,473,214 A	12/1995	Hildebrand	5,828,768 A	10/1998	Eatwell et al.	
5,473,701 A	12/1995	Cezanee et al.	5,835,608 A	11/1998	Warnaka et al.	
5,473,702 A	12/1995	Yoshida et al.	5,838,805 A	11/1998	Warnaka et al.	
5,475,761 A	12/1995	Eatwell	5,874,918 A	3/1999	Czarnecki et al.	
5,479,562 A	* 12/1995	Fielder et al.	5,909,495 A	6/1999	Andrea	
5,481,615 A	1/1996	Eatwell et al.	5,914,877 A	* 6/1999	Gulick	364/400.01
5,485,515 A	1/1996	Allen et al.	5,914,912 A	6/1999	Yang	
5,493,615 A	2/1996	Burke et al.	5,995,150 A	* 11/1999	Hsieh et al.	348/409
5,502,869 A	4/1996	Smith et al.				
5,511,127 A	4/1996	Warnaka				
5,511,128 A	4/1996	Lindeman				
5,515,378 A	5/1996	Roy, III et al.	EP	0 583 900 A1	2/1994	
5,524,056 A	6/1996	Killion et al.	EP	0 595 457 A1	5/1994	
5,524,057 A	6/1996	Akiho et al.	EP	0 721 251	7/1996	
5,526,432 A	6/1996	Denenberg	EP	0 724 415	11/1996	
5,546,090 A	8/1996	Roy, III et al.	FR	2305909	10/1976	
5,546,467 A	8/1996	Denenberg	GB	1 160 431	8/1969	
5,550,334 A	8/1996	Langley	GB	1 289 993	9/1972	
5,553,153 A	9/1996	Eatwell	GB	1 378 294	12/1974	
5,563,817 A	10/1996	Ziegler et al.	GB	2 172 769 A	9/1986	
5,568,557 A	10/1996	Ross et al.	GB	2 239 971 B	7/1991	
5,581,620 A	12/1996	Brandstein et al.	GB	2 289 593 A	11/1995	
5,592,181 A	1/1997	Cai et al.	JP	56-89194	7/1981	
5,592,490 A	1/1997	Barratt et al.	JP	59-64994	4/1984	
5,600,106 A	2/1997	Langley	JP	62-189898	8/1987	
5,604,813 A	2/1997	Evans et al.	JP	1-149695	6/1989	
5,615,175 A	3/1997	Cater et al.	JP	1-314098	12/1989	
5,617,479 A	4/1997	Hildebrand et al.	JP	2-070152	3/1990	
5,619,020 A	4/1997	Jones et al.	JP	3-169199	7/1991	
5,621,656 A	4/1997	Langley	JP	3-231599	10/1991	
5,625,697 A	4/1997	Bowen et al.	JP	4-16900	1/1992	
5,625,880 A	4/1997	Goldburg et al.	WO	WO 88/09512	12/1988	
5,627,746 A	5/1997	Ziegler, Jr. et al.	WO	WO 92/05538	4/1992	
5,627,799 A	5/1997	Hoshuyama	WO	WO 92/17019	10/1992	
5,638,022 A	6/1997	Eatwell	WO	WO 94/16517	7/1994	
5,638,454 A	6/1997	Jones et al.	WO	WO 95/08906	3/1995	
5,638,456 A	6/1997	Conley et al.	WO	WO 96/15541	5/1996	
5,642,353 A	6/1997	Roy, III et al.	WO	WO 97/23068	6/1997	

FOREIGN PATENT DOCUMENTS

OTHER PUBLICATIONS

- Edward J. Foster, "Switched on Silence", Popular Science, 1994, p. 33.
- Kuo, *Automatic Control of Systems*, pp. 504–585.
- Luenberger, *Optimization by Vector Space Method*, pp. 134–138.
- Ogata, *Modern Control Engineering*, pp. 474–508.
- Oppenheim Schafer, *Digital Signal Processing* (Prentice Hall) pp. 542–545.
- P.P. Vaidyanathan, "Multirate Digital Filters, Filter Banks, Polyphase Networks, and Applications; A Tutorial," IEEE Proc., vol. 78, No. 1, Jan. 1990.
- P.P. Vaidyanathan, "Quadrature Mirror Filter Banks, M-band Extensions and Perfect-Reconstruction Techniques," IEEE ASSP Magazine, Jul. 1987, pp. 4–20.
- Rabiner et al., IEEE Trans. on Acous., vol. ASSP-24, No. 5, Oct. 1976, pp. 399–418.
- Rubiner et al., *Digital Processing of Speech Signals* (Prentice Hall, 1978) pp. 130–135.
- Sapontis, *Probability, Lambda Variables and Structural Processes*, pp. 467–474.
- Scott C. Douglas, "A Family of Normalized LMS Algorithms," IEEE Signal Proc. Letters, vol. 1, No. 3, Mar. 1994.
- Sewald et al., "Application of . . . Beamforming to Reject Turbulence Noise in Airducts," IEEE ICASSP vol. 5, No. CONF-21, May 7, 1996, pp. 2734–2737.
- White, *Moving-Coil Earphone Design*, 1963, pp. 188–194.
- Widrow et al., "Adaptive Noise Canceling: Principles and Applications," Proc. IEEE, vol. 63, No. 12, Dec. 1975, pp. 1692–1716.
- Youla et al., IEEE Trans. on Acous., vol. MI-1, No. 2, Oct. 1982, pp. 81–101.

* cited by examiner

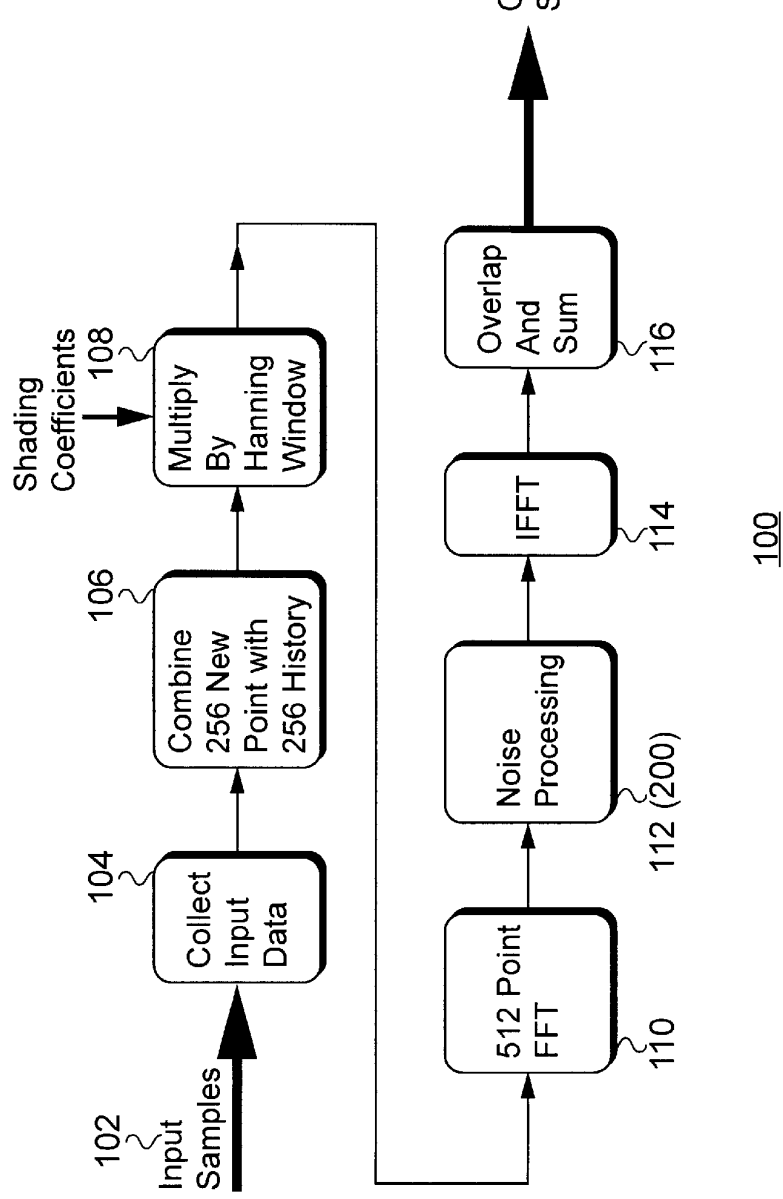

Spectral Subtraction System
FIG. 1

Explore Litigation Insights

Docket Alarm provides insights to develop a more informed litigation strategy and the peace of mind of knowing you're on top of things.

Real-Time Litigation Alerts



Keep your litigation team up-to-date with **real-time alerts** and advanced team management tools built for the enterprise, all while greatly reducing PACER spend.

Our comprehensive service means we can handle Federal, State, and Administrative courts across the country.

Advanced Docket Research



With over 230 million records, Docket Alarm's cloud-native docket research platform finds what other services can't. Coverage includes Federal, State, plus PTAB, TTAB, ITC and NLRB decisions, all in one place.

Identify arguments that have been successful in the past with full text, pinpoint searching. Link to case law cited within any court document via Fastcase.

Analytics At Your Fingertips



Learn what happened the last time a particular judge, opposing counsel or company faced cases similar to yours.

Advanced out-of-the-box PTAB and TTAB analytics are always at your fingertips.

API

Docket Alarm offers a powerful API (application programming interface) to developers that want to integrate case filings into their apps.

LAW FIRMS

Build custom dashboards for your attorneys and clients with live data direct from the court.

Automate many repetitive legal tasks like conflict checks, document management, and marketing.

FINANCIAL INSTITUTIONS

Litigation and bankruptcy checks for companies and debtors.

E-DISCOVERY AND LEGAL VENDORS

Sync your system to PACER to automate legal marketing.